



TRANE®

Installation, Operation, and Maintenance

S&P Unit Heaters

Model Numbers:

UHSB
UHPB

September 2008

UH-SVX01A-EN



Preface and Warnings and Cautions

Hazard Identification

ATTENTION:

Warnings and Cautions appear at appropriate sections throughout this literature. Read these carefully.

WARNING

Indicates a potentially hazardous situation which, if not avoided, could result in death or serious injury.

CAUTION

Indicates a potentially hazardous situation which, if not avoided, may result in minor or moderate injury.

NOTICE

Indicates a situation that could result in equipment or property-damage-only accidents.

WARNING

Operational Hazards!

Improper installation, adjustment, alteration, service or maintenance can cause property damage, injury or death. Read the installation, operating and maintenance instructions thoroughly before installing or servicing this equipment.

WARNING

Compliance Hazards!

Failure to comply with the general safety information may result in extensive property damage, severe personal injury or death.

WARNING

Unit Alterations!

Do not alter the unit heater in any way or damage to the unit and/or severe personal injury or death may occur!

WARNING

Voltage Hazard!

Disconnect all power supplies before installing or servicing the heater. If the power disconnect is out of sight, lock it in the open position and tag it to prevent unexpected application of power. Failure to do so could result in fatal electric shock, or severe personal injury.

WARNING Voltage Hazard!

Do not depend upon a thermostat or other switch as sole means of disconnecting power when installing or servicing heater. Always disconnect power at main circuit breaker as described above. Failure to do so could result in fatal electric shock.

CAUTION Equipment Damage!

Insure that all power sources conform to the requirements of the unit heater or damage to the unit will result!

Follow installation instructions CAREFULLY to avoid creating unsafe conditions. All external wiring must conform to applicable current local codes, and to the latest edition of the National Electric Code ANSI/NFPA No. 70. In Canada, all external wiring must conform to the Canadian Electric Code, Part 1 CSA Standard C22.1 All wiring should be done and checked by a qualified electrician using copper wire only. All steam and hot water connections should be made and leaktested by a suitably qualified individual, per instructions in this manual. Also follow procedures listed on the "Unit Equipment Start-Up Sheet" located in this manual.

Make certain that the power source conforms to the electrical requirements of the heater.

Special attention must be given to any grounding information pertaining to this heater. To prevent the risk of electrocution, the heater must be securely and adequately grounded. This should be accomplished by connecting a grounded conductor between the service panel and the heater. To ensure a proper ground, the grounding means must be tested by a qualified electrician.

Do not insert fingers or foreign objects into the heater or its air moving device. Do not block or tamper with the heater in any manner while in operation or just after it has been turned off, as some

parts may be hot enough to cause injury.

Note: To meet CSA and OSHA requirements, units mounted below 8 feet (2.4m) from the floor must be equipped with an OSHA fan guard.

It is good practice to have a shutoff switch on the electrical power lines controlling the heater. Whenever a unit is serviced, shut power off to the unit.

Since these units are installed in most instances higher than 8 feet (2.4m), proper type of ladders or scaffolding should be used, as set up by OSHA requirements. It is the owner's responsibility to provide any scaffolding or other apparatus required to perform emergency service or annual/periodic maintenance to this equipment.

In industrial plants, professional maintenance crews should service this equipment.

All Horizontal Unit Heaters are shipped fully assembled and may be used for steam or hot water applications. Coils are factory tested at 250 psig (1723.5 kg).

All Vertical Unit Heaters are shipped fully assembled and may be used for steam or hot water applications. Coils are factory tested at 400 psig air under water. Fans are balanced and motors are prelubricated.

Unless otherwise specified, the following conversions may be used for calculating SI unit measurements:

1 foot = 0.305 m

1 inch = 25.4 mm

1 psig = 6.894 kPa

1 pound = 0.453 kg

1 gallon = 3.785 L

1 inch water column = 0.249 kPa

meter/second = FPM ÷ 196.8

liter/second = CFM x 0.472

1000 Btu per hour = 0.293 kW

1000 Btu/Cu. Ft. = 37.5 MJ/m³

1 cubic foot = 0.028 m³



Contents

Model Number Description	4
Location	6
Installation	13
Fan Guard/Louver Installation	21
Dimensional Data	23
Technical Data	28
Options	30
Electrical Connections	32
Motor Data	38
Steam Performance Data	41
Hot Water Performance Data	46
Maintenance	55
Warranty Info	57



Model Number Description

U H S B A 1 8 1 T A A 1 0 1 A 0 A 0 A 1
 1 2 3 4 5 6 7 8 9 10 11 12 13 14 15 16 17 18 19 20

Description

Vertical hydronic unit heaters are designed for installation requiring down flow air delivery, offered in 15 sizes ranging from 41,300 to 705,000 BTU/Hr., and use with steam or hot water. Low output (increased airflow) units are available for high ceiling applications. The designs are certified by CSA (per CAN/CSA-C22.2 and UL1995). Do not alter these units in any way and do not attach any ductwork to these units. If you have any questions after reading this manual, contact the manufacturer.

horizontal units range from 18,000 to 360,000 (5.3 to 105.5 kW) and can operate with either hot water or steam. Both units are furnished with totally enclosed motors, with explosion proof motors as optional on header types. The designs are certified by CSA (per CAN/CSA-C22.2 and UL1995). **Do not alter these units in any way and do not attach any ductwork to the units.** If you have any questions after reading this manual, contact the manufacturer.

Service Model Number Description

DIGIT 1,2,3 – PRODUCT TYPE

UHP
 UHS

DIGIT 4 – DEVELOPMENT SEQUENCE

B

DIGIT 5, 6, 7 – CAPACITY/COIL TYPE

Hot Water Only "Serpentine Type Coil" Model S

A08	8,030 BTU/HR
A18	18,400 BTU/HR
A25	24,800 BTU/HR
A36	35,900 BTU/HR

Steam or Hot Water "Header Type Coil" Model S

018	18,000 BTU/HR
024	24,000 BTU/HR
036	36,000 BTU/HR
048	48,000 BTU/HR
060	60,000 BTU/HR
072	72,000 BTU/HR
084	84,000 BTU/HR
096	96,000 BTU/HR
108	108,000 BTU/HR
120	120,000 BTU/HR
132	132,000 BTU/HR
144	144,000 BTU/HR
156	156,000 BTU/HR
180	180,000 BTU/HR
204	204,000 BTU/HR
240	240,000 BTU/HR
280	280,000 BTU/HR
300	300,000 BTU/HR
360	360,000 BTU/HR

Steam or Hot Water Model P

042	42,000 BTU/HR
064	64,000 BTU/HR
080	80,000 BTU/HR
102	102,000 BTU/HR
122	122,000 BTU/HR
146	146,000 BTU/HR
166	166,000 BTU/HR
202	202,000 BTU/HR
252	252,000 BTU/HR



Figure 1. Vertical Unit (bottom)



Figure 3. Serpentine Type



Figure 2. Vertical Unit (top)

Horizontal hydronic unit heaters are available in both serpentine and header type units. Serpentine units offer outputs from 8,030 to 35,900 BTU's (2.4 to 10.5 kW) and are ideal for hot water (only) installations with limited clearances. Header type

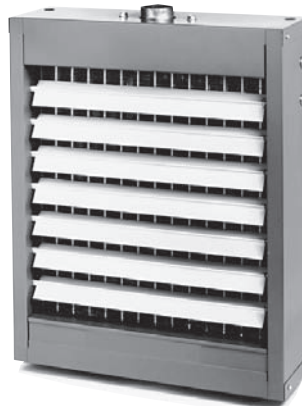

Figure 4. Header Type



Model Number Description

280	280,000 BTU/HR
336	336,000 BTU/HR
384	384,000 BTU/HR
500	500,000 BTU/HR
600	600,000 BTU/HR
720	720,000 BTU/HR

DIGIT 8— VOLTAGE

1	115/1/60
3	230/1/60 (115 V motor with Transformer)
4	208/3/60
5	230/3/60
6	460/3/60
7	575/60/3 (Totally Enclosed) (P only)

DIGIT 9 - MOTOR TYPE

T	Totally Enclosed
E	Explosion Proof

DIGIT 10- DESIGN SEQUENCE

A

DIGIT 11- TUBE MATERIAL

A	Copper
B	Steel (P only)

DIGIT 12- FAN GUARD

1	OSHA Fan Guard
2	Standard Fan Guard (3 phase or Explosion Proof motors only)
3	Standard Fan Guard (Unit Capacities 240 - 360)
4	None (P only)

DIGIT 13 - SPECIAL COATING

0	No Special Coating
A	Phenolic Coating (Baked)
B	Epoxy
C	Epoxy Phenolic

DIGIT 14 - DISCONNECT SWITCH

0	None
1	Disconnect switch

DIGIT 15 - THERMOSTATS (LINE VOLTAGE)

0	None
A	Light Duty TSTAT w/ subbase Line Volts 8 Amps
B	Heavy Duty TSTAT w/ subbase&guard Line Volts 16 Amps+A32

DIGIT 16 - THERMOSTAT COVER

0	None
A	Locking Thermostat Cover

DIGIT 17 - Manual Starter

0	None
A	Manual Starter

DIGIT 18 - STEAM & HOT WATER CONTROL

0	None
1	Strap on Hot Water Control
2	Steam Pressure Control (Open on rise in pressure)
3	Steam Pressure Control (Close on rise in pressure)
4	5.0 Amp Speed Control Switch (Capacities 18 - 108 only)

DIGIT 19 - VERTICAL LOUVER

0	None
A	Vertical Louver
B	Fin Diffuser (P only)
C	Fin Diffuser w/ Coating (Ponly)

Location

It is assumed that the design engineer has selected, sized, and located in the area to be heated. However, the information given here may be of additional help to the installer. These sketches indicate suggested basic locations for different types of unit heaters.

Horizontal unit heaters should be located to give a circulatory motion, preferably in the outer perimeter of the building. The units should be spaced to properly blanket the areas with warm air.

The unit should be suspended from connections provided in the unit by means of rods. The rods should then be attached to solid supports of the building.

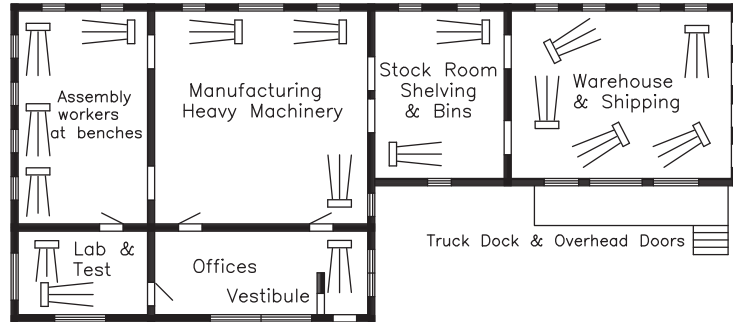

Figure 5.

Table 1.

Model No	Maximum Mounting HT. ft (m)	Approx. Max. Throw ft (m)
A08	8 (2.4)	20 (6.1)
A18	8 (2.4)	25 (7.6)
A25	9 (2.7)	29 (8.8)
A36	9 (2.7)	29 (8.8)
18	8 (2.4)	20 (6.1)
24	8 (2.4)	24 (7.3)
36	9 (2.7)	28 (8.5)
48	9 (2.7)	30 (9.1)
60	10 (3.0)	30 (9.1)
72	10 (3.0)	29 (8.8)
84	10 (3.0)	30 (9.1)
96	11 (3.4)	38 (11.6)
108	11 (3.4)	40 (12.2)
120	12 (3.7)	40 (12.2)
132	13 (4.0)	54 (16.5)
144	13 (4.0)	55 (16.8)
156	13 (4.0)	55 (16.8)
180	13 (4.0)	53 (16.2)
204	13 (4.0)	55 (16.8)
240	14 (4.3)	57 (17.4)
280	14 (4.3)	57 (17.4)
300	15 (4.6)	58 (17.7)
360	15 (4.6)	60 (18.3)

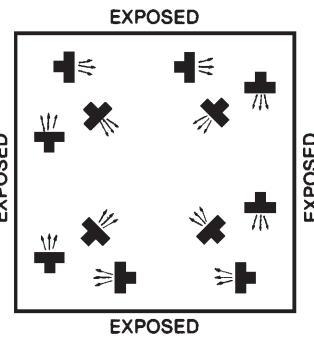

Figure 6.

Figure 6 represents a large square area with exposed walls and roof; units are blanketing all exposed surfaces.

Figure 7 is based on 2 PSI (13.8 kPa) steam pressure and 60 °F (16 °C) entering air temperature.

A narrow area with four exposed walls either with or without roof exposure.

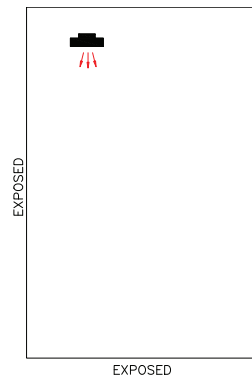

Figure 8.

A small area with exposed walls requiring one unit.

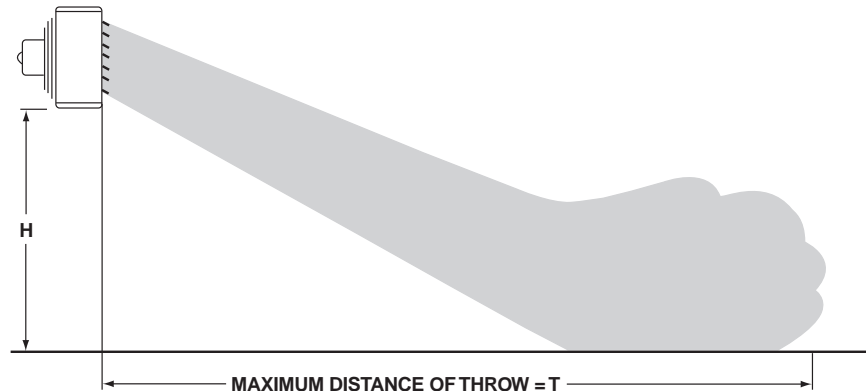

Figure 7. Mounting Height and Approx. Heat Throw

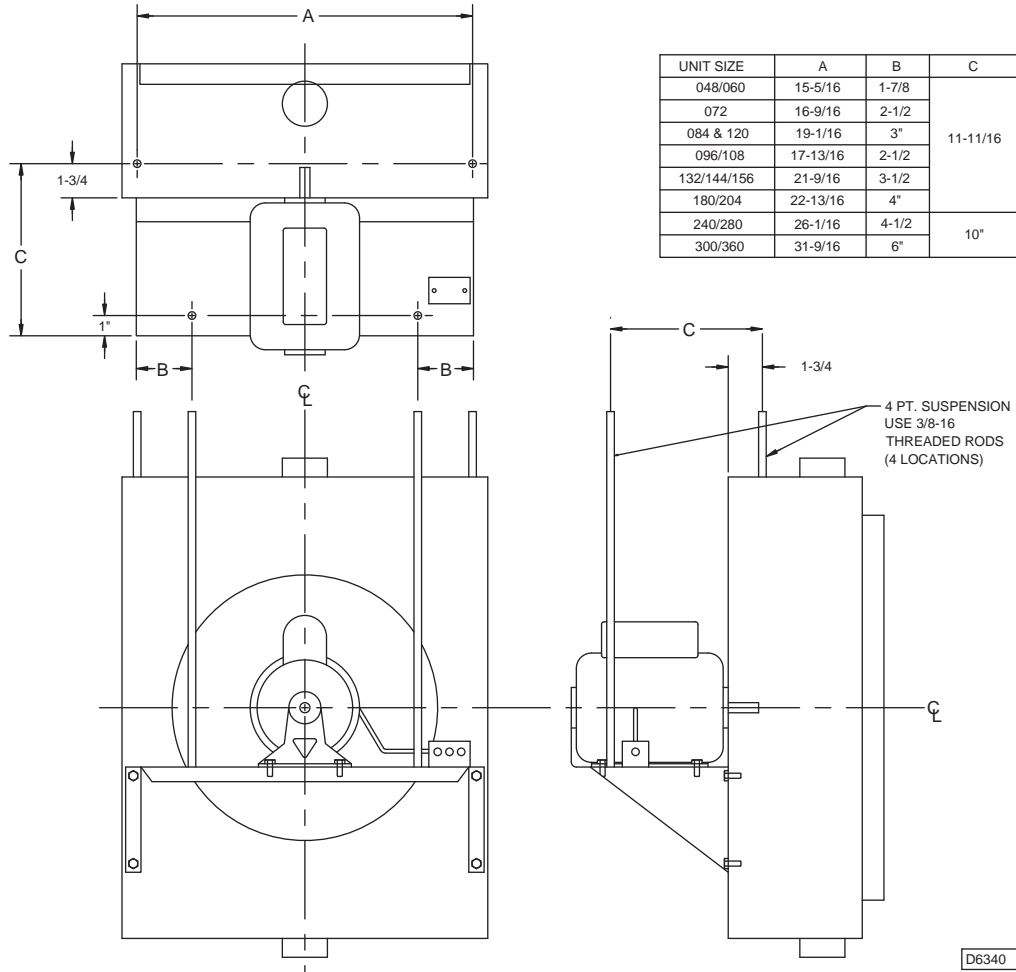

Figure 9. Four Point Suspension-Shelf Mounted Motors Only

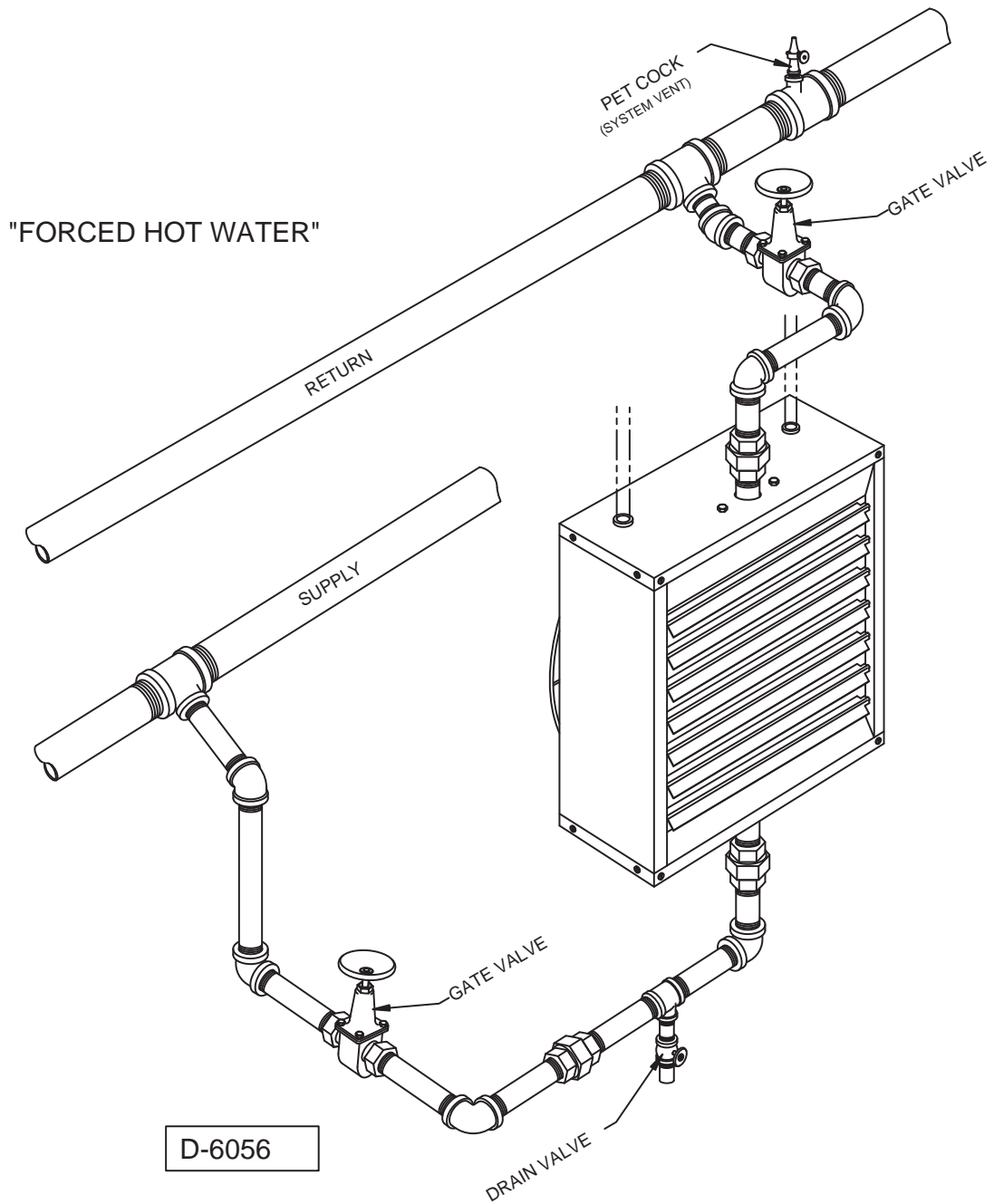

Figure 10. Forced Hot Water

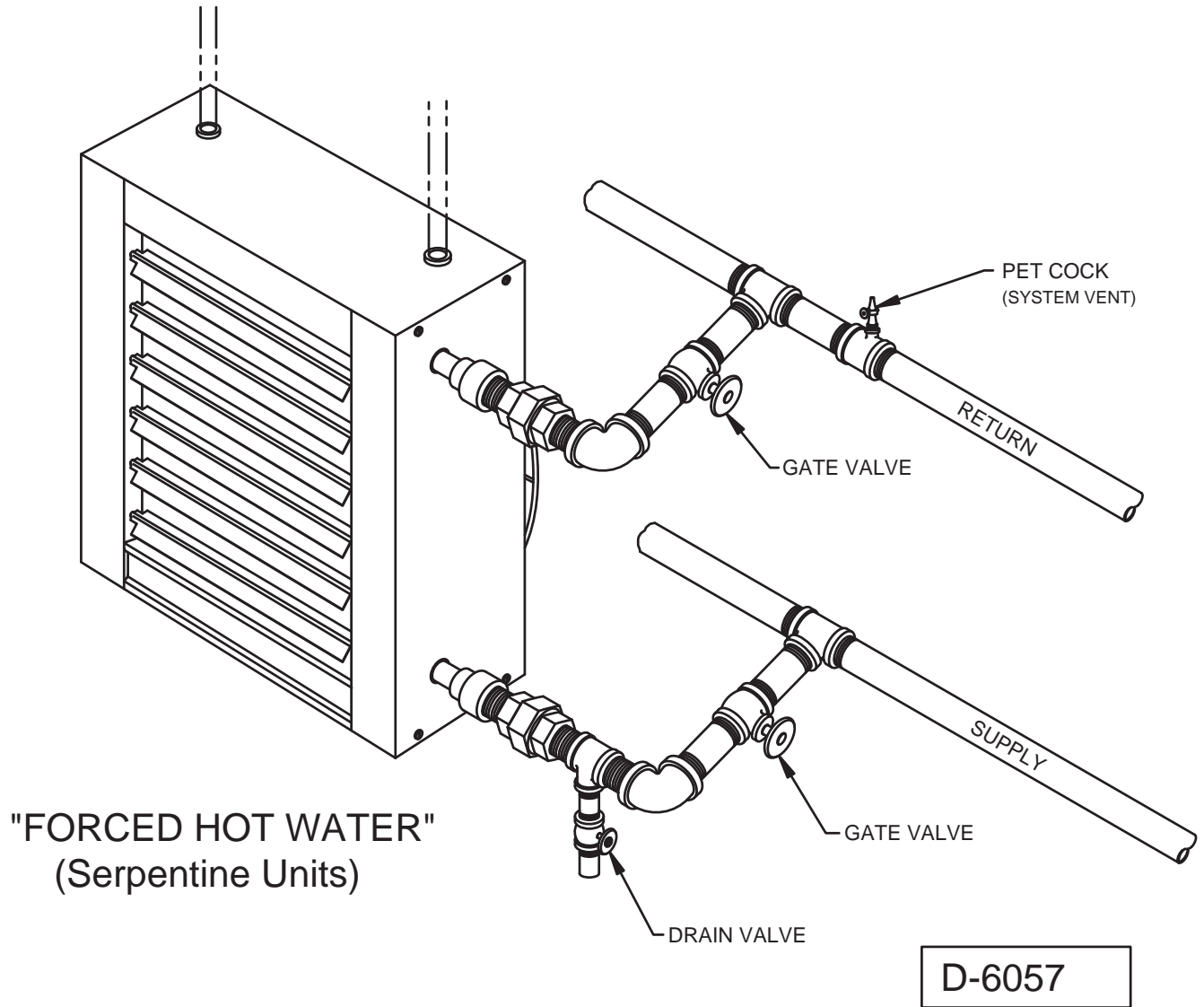

Figure 11. Forced Hot Water: Serpentine Unit Only

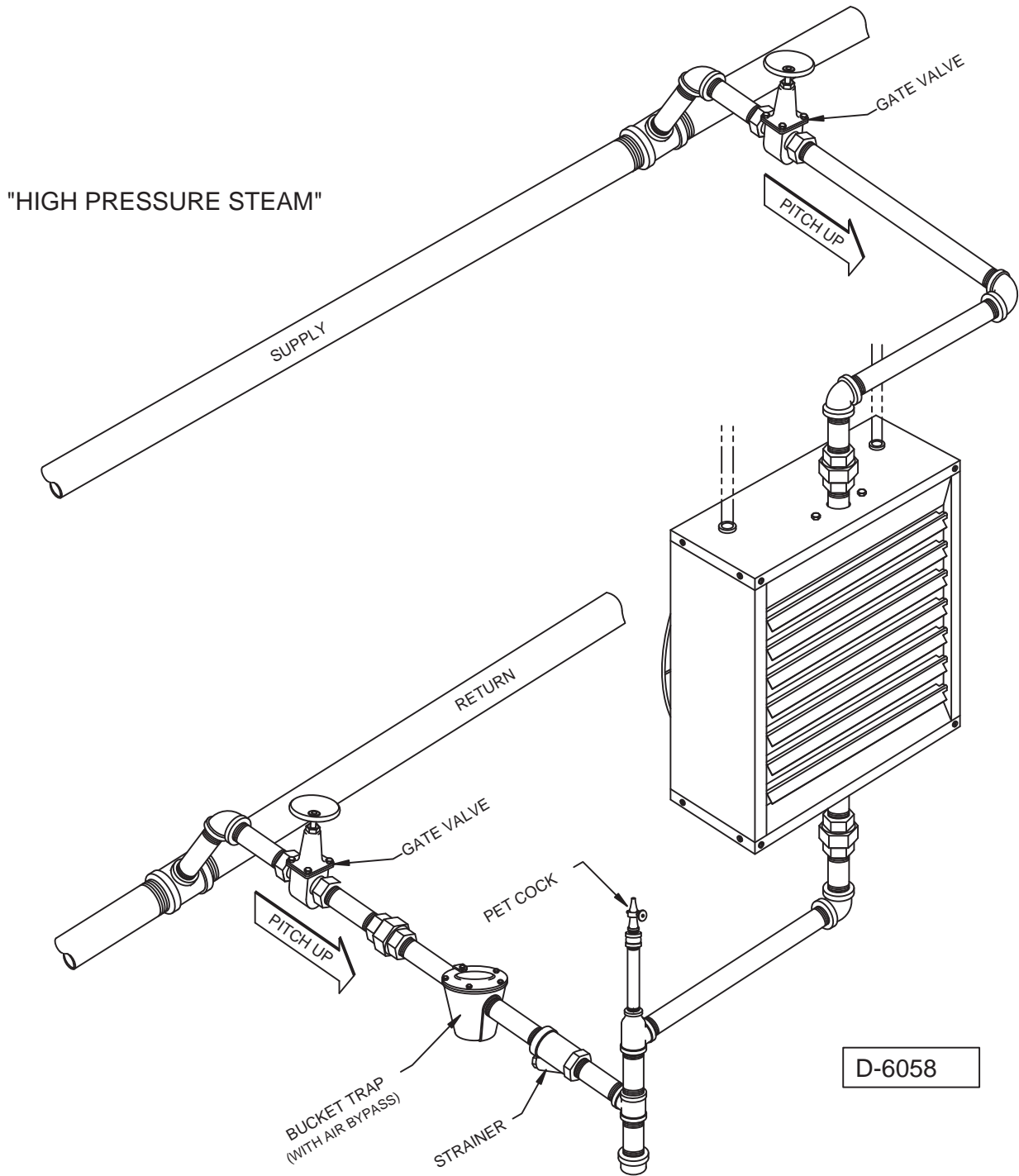

Figure 12. High Pressure Steam

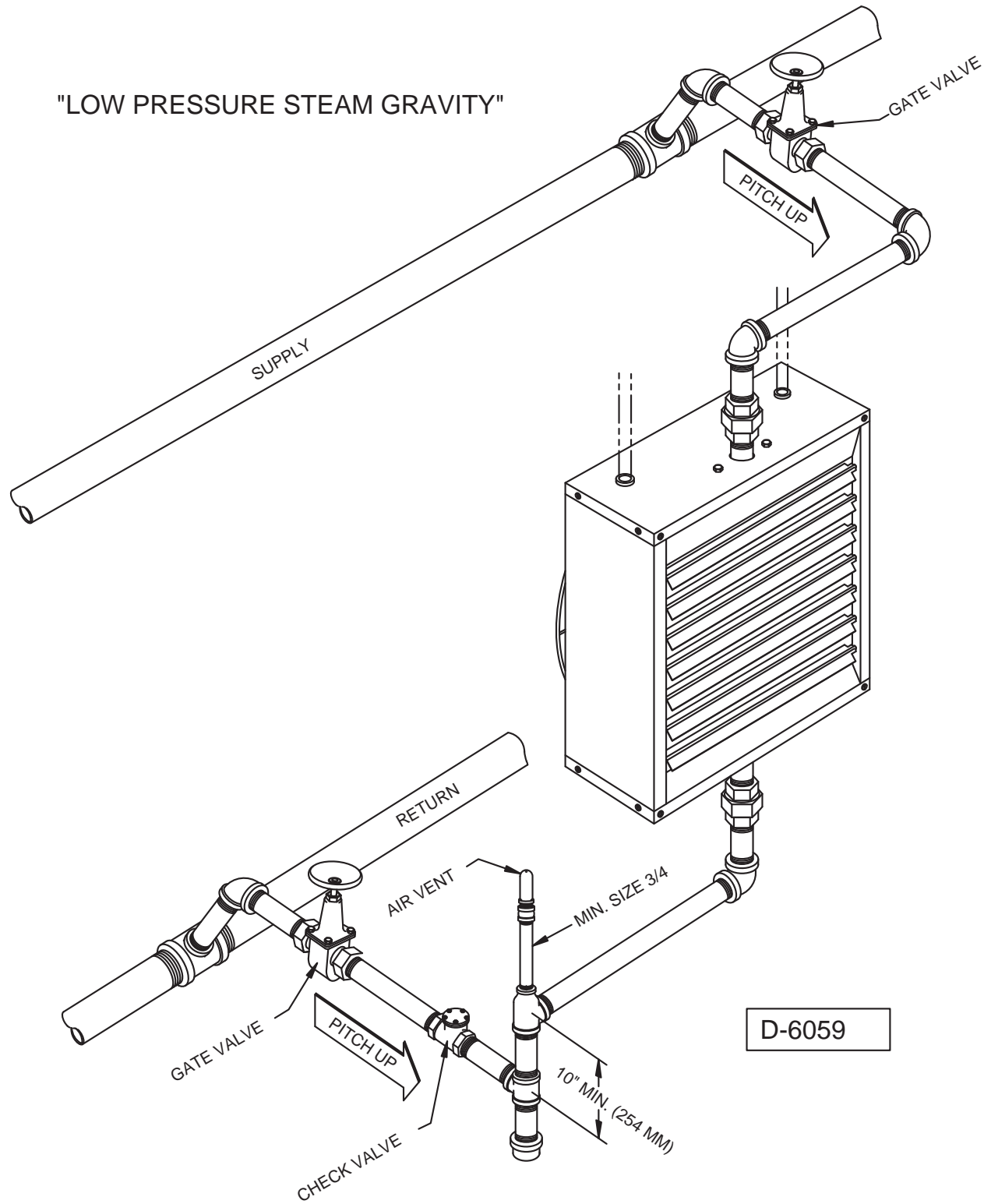

Figure 13. Low Pressure Steam Gravity

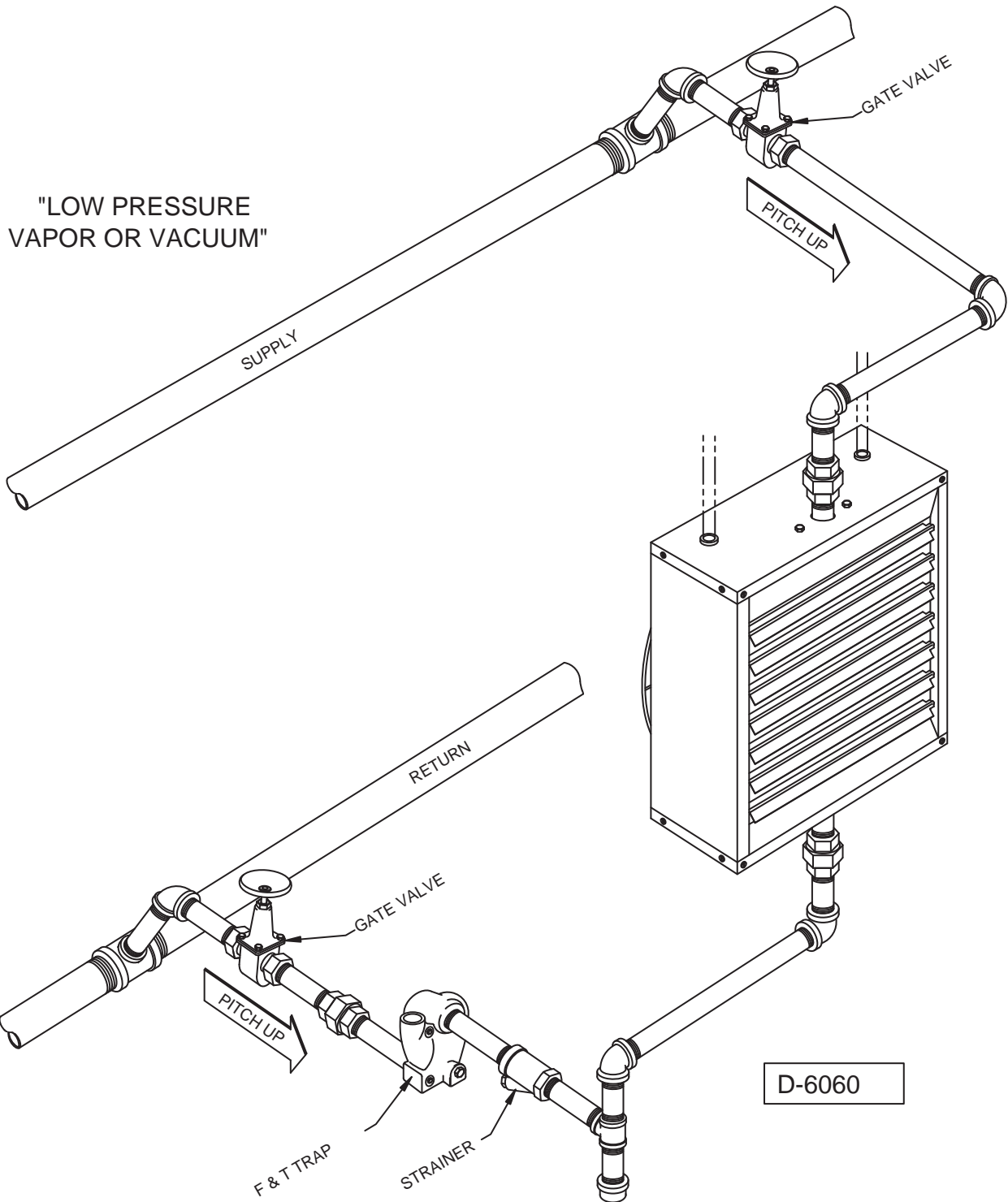

Figure 14. Low Pressure Vapor Or Vacuum



Installation

Installation: P Type

Periodic Service

⚠️ WARNING Heavy Objects!

Ensure that all hardware used in the suspension of each unit heater is more than adequate for the job. Failure to do so may result in extensive property damage, severe personal injury or death.

⚠️ CAUTION Lifting/Suspension Methods!

Make certain that the lifting methods used to lift the heater and the method of suspension used in the field installation of the heater are capable of uniformly supporting the weight of the heater at all times. Failure to heed this warning may result in property damage or personal injury!

NOTICE Structural Integrity!

Make certain that the structure to which the heater is mounted is capable of supporting its weight. Under no circumstances must the piping or the electrical conduit be used to support the heater; or should any other objects (i.e. ladder, person) lean against the heater or the electrical conduit for support.

NOTICE Performance Failure!

Unit heaters must be hung level from side to side and from front to back. Failure to do so will result in poor performance and or premature failure of the unit.

It is assumed that the design engineer has selected, sized, and located in the area to be heated by the design engineer. However, the information given here may be of additional help to the installer.

Vertical unit heaters should be located to give spot heating or a circulatory distribution, preferably near the outer perimeter of the building. The units should be spaced to properly blanket the areas with

warm air. Place the units at points of greatest heat loss. Blanket outside doorway and provide ample coverage of window areas. Keep units away from obstructions that will impede the full and natural air delivery of the units.

Install unit heaters to meet CSA and OSHA requirements; Vertical Unit Heaters mounted lower than 2.4 meters (8 feet) from the floor must be equipped with an OSHA fan guard. Weldnuts are provided at the top of all units for suspension purposes. The unit should be suspended from connections provided in the unit by means of rods. The rods should then be attached to solid supports of the building.

Units must hang level vertically and horizontally.

Provide sufficient clearance around units for maintenance purposes. This includes at least 7 inches above all Vertical Unit Heaters even though the motor is removable through the bottom.

Isolators are not required but may be desirable for some applications. Refer to [Table 2](#) for Unit Weights.

Table 2. Unit Weights-Lbs

Vertical Unit Heaters	
Unit	Weights (Lbs.)
042	26
064	32
080	36
102	51
122	54
146	69
166	69
202	75
252	115
280	120
336	120
384	126
500	267
600	210
720	260

EXAMPLE

[Table 4](#) lists maximum mounting height and floor spread data of warm air coverage at floor level with louver cone diffusers. Correction factors for various water temp. and psig of steam are in [Table 7](#).

An approximation of the floor spread when operating on other than 2 lb. Steam or 219 degree may be obtained by ratioing the new floor spread and the maximum mounting height to that at 2 lb. steam or 219 degree hot water.

Following is an example:

Determine the floor spread and the maximum mounting height of a std. model 80 unit heater with a cone diffuser set at 90 degrees, operating on 280 degree hot water.

From [Table 6](#), maximum mounting height of a model 80 at 219 degree hot water is 18.5 ft. with floor coverage of 14.0 ft. diameter. The maximum mounting height correction factor at 280 degree hot water is 0.80.

$$18.5 \text{ ft.} \times 0.80 = 14.8 \text{ ft.}$$

Maximum mounting height of a model 80 using 280 degree hot water.

"X" = floor spread of model 80 using 280 degree hot water.

$$X = 14.8 \times 14.0 / 18.5$$

$$X = 207.2 / 18.5$$

$$X = 11.2 \text{ ft.}$$



Installation

Table 3. Maximum Mounting Height in Feet with and without Louver Cone Diffuser

Unit Size	Steam Pressure (PSI)					Unit Size	Steam Pressure (PSI)				
	2 (13.8)	5 (34.5)	10 (68.9)	50 (344.7)	75 (517.1)		2 (13.8)	5 (34.5)	10 (68.9)	50 (344.7)	75 (517.1)
042	10.5 (3.2)	10.0 (3.0)	10.0 (3.0)	9.0 (2.7)	8.0 (2.4)	080L	18.0 (5.5)	17.5 (5.3)	17.5 (5.3)	15.0 (4.6)	14.0 (4.3)
	12.5 (3.8)	12.0 (3.7)	12.0 (3.7)	11.0 (3.4)	10.0 (3.0)		22.0 (6.7)	21.0 (6.4)	21.0 (6.4)	19.0 (5.8)	18.0 (5.5)
042*	7.5 (2.3)	7.5 (2.3)	7.5 (2.3)	7.5 (2.3)	7.5 (2.3)	080L*	13.0 (4.0)	12.5 (3.8)	12.0 (3.7)	11.0 (3.4)	10.5 (3.2)
	9.0 (2.7)	8.5 (2.6)	8.5 (2.6)	7.5 (2.3)	7.5 (2.3)		17.0 (5.2)	16.5 (5.0)	16.0 (4.9)	14.0 (4.3)	13.5 (4.1)
042L	12.5 (3.8)	12.0 (3.7)	12.0 (3.7)	10.5 (3.2)	9.5 (2.9)	102	14.0 (4.3)	13.5 (4.1)	13.0 (4.0)	11.5 (3.5)	11.0 (3.4)
	14.5 (4.4)	14.0 (4.3)	13.5 (4.1)	12.0 (3.7)	11.5 (3.5)		17.0 (5.2)	16.5 (5.0)	16.0 (4.9)	14.0 (4.3)	13.5 (4.1)
042L*	9.0 (2.7)	8.5 (2.6)	8.5 (2.6)	7.5 (2.3)	7.5 (2.3)	102*	11.0 (3.4)	10.5 (3.2)	10.5 (3.2)	9.5 (2.9)	9.0 (2.7)
	10.5 (3.2)	10.0 (3.0)	10.0 (3.0)	9.0 (2.7)	8.5 (2.6)		13.5 (4.1)	13.0 (4.0)	13.0 (4.0)	12.0 (3.7)	11.5 (3.5)
064	12.0 (3.7)	11.5 (3.5)	11.5 (3.5)	10.0 (3.0)	9.5 (2.9)	102L	17.5 (5.3)	17.0 (5.2)	16.5 (5.0)	15.0 (4.6)	14.5 (4.4)
	14.5 (4.4)	14.0 (4.3)	14.0 (4.3)	12.0 (3.7)	11.5 (3.5)		21.5 (6.6)	21.0 (6.4)	20.5 (6.2)	18.5 (5.6)	17.5 (5.3)
064*	9.5 (2.9)	9.0 (2.7)	9.0 (2.7)	8.0 (2.4)	8.0 (2.4)	102L*	15.0 (4.6)	14.5 (4.4)	14.5 (4.4)	13.0 (4.0)	12.5 (3.8)
	11.5 (3.5)	11.0 (3.4)	11.0 (3.4)	9.5 (2.9)	9.0 (2.7)		18.5 (5.6)	18.0 (5.5)	18.0 (5.5)	16.0 (4.9)	15.0 (4.6)
064L	15.0 (4.6)	14.5 (4.4)	14.5 (4.4)	12.5 (3.8)	12.0 (3.7)	122	16.0 (4.9)	15.5 (4.7)	15.5 (4.7)	14.0 (4.3)	13.5 (4.1)
	19.0 (5.8)	18.5 (5.6)	18.5 (5.6)	16.5 (5.0)	16.0 (4.9)		19.5 (5.9)	19.0 (5.8)	18.5 (5.6)	17.0 (5.2)	16.0 (4.9)
064L*	11.5 (3.5)	11.0 (3.4)	11.0 (3.4)	9.5 (2.9)	9.0 (2.7)	122L	21.0 (6.4)	20.5 (6.2)	20.0 (6.1)	17.5 (5.3)	17.0 (5.2)
	14.0 (4.3)	13.5 (4.1)	13.5 (4.1)	12.0 (3.7)	11.5 (3.5)		26.0 (7.9)	25.5 (7.8)	25.0 (7.6)	22.5 (6.9)	21.5 (6.6)
080	15.0 (4.6)	14.5 (4.4)	14.0 (4.3)	12.0 (3.7)	11.5 (3.5)	146	15.5 (4.7)	15.0 (4.6)	14.5 (4.4)	13.0 (4.0)	12.0 (3.7)
	18.5 (5.6)	18.0 (5.5)	17.5 (5.3)	15.5 (4.7)	15.0 (4.6)		19.0 (5.8)	18.5 (5.6)	18.0 (5.5)	16.0 (4.9)	15.5 (4.7)
080*	11.0 (3.4)	10.5 (3.2)	10.5 (3.2)	9.0 (2.7)	8.5 (2.6)	146L	18.0 (5.5)	17.5 (5.3)	17.5 (5.3)	15.0 (4.6)	14.0 (4.3)
	13.5 (4.1)	13.0 (4.0)	13.0 (4.0)	11.5 (3.5)	11.0 (3.4)		22.5 (6.9)	22.0 (6.7)	21.5 (6.6)	18.5 (5.6)	18.0 (5.5)

NOTES:

* = Low Speed

L = Low output model with all air ports open

Figures in bold face show maximum mounting height with louver cone diffusers set vertically.

Above table based on 60°F entering air temperature. In providing for the use of diffusers, it must be remembered that adjustment of a LCD to deflect air toward horizontal immediately lowers the mounting height limit.



Installation

Table 4. Maximum Mounting Height in Feet with and without Louver Cone Diffuser

Unit Size	Steam Pressure (PSI)					Unit Size	Steam Pressure (PSI)				
	2 (13.8)	5 (34.5)	10 (68.9)	50 (344.7)	75 (517.1)		2 (13.8)	5 (34.5)	10 (68.9)	50 (344.7)	75 (517.1)
166	18.0 (5.5)	17.5 (5.3)	17.0 (5.2)	14.5 (4.4)	14.0 (4.3)	336L	29.0 (8.8)	28.5 (8.7)	28.0 (8.5)	25.0 (7.6)	24.0 (7.3)
	22.5 (6.9)	22.0 (6.7)	21.5 (6.6)	19.0 (5.8)	18.0 (5.5)		36.0 (11.0)	35.0 (10.7)	34.0 (10.4)	30.0 (9.1)	29.0 (8.8)
166L	22.0 (6.7)	21.5 (6.6)	21.0 (6.4)	18.5 (5.6)	17.5 (5.3)	384	28.5 (8.7)	28.0 (8.5)	27.5 (8.4)	24.0 (7.3)	23.0 (7.0)
	27.5 (8.4)	27.0 (8.2)	26.5 (8.1)	23.5 (7.2)	22.5 (6.9)		35.5 (10.8)	35.0 (10.7)	34.0 (10.4)	30.0 (9.1)	29.0 (8.8)
202	22.0 (6.7)	21.5 (6.6)	21.0 (6.4)	18.5 (5.6)	17.5 (5.3)	384L	32.5 (9.9)	31.5 (9.6)	30.5 (9.3)	27.5 (8.4)	26.5 (8.1)
	27.5 (8.4)	27.0 (8.2)	26.5 (8.1)	24.0 (7.3)	23.0 (7.0)		41.0 (12.5)	40.0 (12.2)	39.0 (11.9)	35.0 (10.7)	33.5 (10.2)
202L	25.5 (7.8)	25.0 (7.6)	24.5 (7.5)	22.0 (6.7)	21.0 (6.4)	500	29.5 (9.0)	29.0 (8.8)	28.5 (8.7)	25.0 (7.6)	24.0 (7.3)
	31.5 (9.6)	31.0 (9.4)	30.5 (9.3)	27.0 (8.2)	26.0 (7.9)		36.5 (11.1)	36.0 (11.0)	35.5 (10.8)	32.0 (9.8)	30.5 (9.3)
252	20.0 (6.1)	19.5 (5.9)	19.0 (5.8)	17.0 (5.2)	16.0 (4.9)	500L	35.0 (10.7)	34.0 (10.4)	33.0 (10.1)	29.0 (8.8)	28.0 (8.5)
	25.0 (7.6)	24.0 (7.3)	23.5 (7.2)	20.5 (6.2)	19.5 (5.9)		43.5 (13.3)	42.5 (13.0)	41.5 (12.6)	35.0 (10.7)	34.0 (10.4)
252L	24.0 (7.3)	23.5 (7.2)	23.0 (7.0)	20.0 (6.1)	19.0 (5.8)	600	34.0 (10.4)	33.0 (10.1)	32.0 (9.8)	28.0 (8.5)	27.0 (8.2)
	29.5 (9.0)	28.5 (8.7)	28.0 (8.5)	24.5 (7.5)	23.5 (7.2)		42.5 (13.0)	41.5 (12.6)	40.5 (12.3)	36.0 (11.0)	34.5 (10.5)
280	21.0 (6.4)	20.5 (6.2)	20.0 (6.1)	17.5 (5.3)	17.0 (5.2)	600L	37.0 (11.3)	36.0 (11.0)	35.0 (10.7)	31.0 (9.4)	30.0 (9.1)
	26.0 (7.9)	25.5 (7.8)	25.0 (7.6)	22.0 (6.7)	21.0 (6.4)		46.5 (14.2)	45.5 (13.9)	44.5 (13.6)	39.0 (11.9)	37.0 (11.3)
280L	25.5 (7.8)	25.0 (7.6)	24.5 (7.5)	21.0 (6.4)	20.0 (6.1)	720	38.5 (11.7)	37.5 (11.4)	36.5 (11.1)	32.0 (9.8)	30.5 (9.3)
	32.0 (9.8)	31.0 (9.4)	30.0 (9.1)	26.0 (7.9)	25.0 (7.6)		48.0 (14.6)	47.0 (14.3)	46.0 (14.0)	40.0 (12.2)	39.0 (11.9)
336	24.0 (7.3)	23.0 (7.0)	22.0 (6.7)	20.0 (6.1)	19.0 (5.8)	720L	42.5 (13.0)	41.5 (12.6)	40.5 (12.3)	35.0 (10.7)	33.5 (10.2)
	30.0 (9.1)	29.0 (8.8)	28.0 (8.5)	25.0 (7.6)	24.0 (7.3)		53.0 (16.2)	52.0 (15.8)	51.0 (15.5)	44.0 (13.4)	42.0 (12.8)

NOTES:

* = Low Speed

L = Low output model with all air ports open

Figures in bold face show maximum mounting height with louver cone diffusers set vertically.

Above table based on 60°F entering air temperature. In providing for the use of diffusers, it must be remembered that adjustment of a LCD to deflect air toward horizontal immediately lowers the mounting height limit.

Table 5. Maximum Spread

MODEL No.	42	64	80	102	122	146	166	202	252	280	336	384	500	600	720
Spread ft (m)	15 (4.6)	17 (5.2)	20 (6.1)	24 (7.3)	26 (7.9)	27 (8.2)	28 (8.5)	32 (9.8)	35 (10.7)	37 (11.3)	45 (13.7)	50 (15.2)	54 (16.5)	57 (17.4)	60 (18.3)

Note: The "spread" is the diameter of the comfort zone at floor level. The above table represents the spread for standard units without a louver cone diffuser and mounted at its maximum height at 2 psi (13.8 kPa) steam pressure and 60°F (16°C) entering air. (See Tables 21 and 22 for maximum mounting heights.)

Table 6. Maximum Mounting Height and Diameter at Floor (Based on 60°F EAT and 219°F EWT or 2 psig steam)

Model	Diffuser Cone 90° See Figure 5A				Diffuser Cone 45° See Figure 5B			
	Standard		Low Output		Standard		Low Output	
	H	D	H	D	H	D	H	D
	ft (m)	ft (m)	ft (m)	ft (m)	ft (m)	ft (m)	ft (m)	ft (m)
42	12.5 (3.8)	11.0 (3.4)	14.5 (4.4)	16.0 (4.9)	9.0 (2.7)	20.0 (6.1)	11.0 (3.4)	25.0 (7.6)
64	14.5 (4.4)	12.0 (3.7)	19.0 (5.8)	19.0 (5.8)	10.0 (3.0)	24.0 (7.3)	12.0 (3.7)	29.0 (8.8)
80	18.5 (5.6)	14.0 (4.3)	22.0 (6.7)	23.0 (7.0)	12.5 (3.8)	26.0 (7.9)	15.0 (4.6)	31.0 (9.4)
102	17.0 (5.2)	18.0 (5.5)	21.5 (6.6)	26.0 (7.9)	11.0 (3.4)	31.0 (9.4)	14.0 (4.3)	35.0 (10.7)
122	19.5 (5.9)	19.0 (5.8)	26.0 (7.9)	29.0 (8.8)	13.0 (4.0)	33.0 (10.1)	16.0 (4.9)	38.0 (11.6)
146	19.0 (5.8)	20.0 (6.1)	22.5 (6.9)	30.0 (9.1)	12.0 (3.7)	39.0 (11.9)	15.5 (4.7)	44.0 (13.4)
166	22.5 (6.9)	21.0 (6.4)	27.5 (8.4)	31.0 (9.4)	13.0 (4.0)	42.0 (12.8)	18.0 (5.5)	48.0 (14.6)
202	27.5 (8.4)	25.0 (7.6)	31.5 (9.6)	35.0 (10.7)	14.0 (4.3)	45.0 (13.7)	21.0 (6.4)	53.0 (16.2)
252	25.0 (7.6)	27.0 (8.2)	29.5 (9.0)	38.0 (11.6)	13.0 (4.0)	47.0 (14.3)	19.0 (5.8)	55.0 (16.8)
280	26.0 (7.9)	29.0 (8.8)	32.0 (9.8)	40.0 (12.2)	15.0 (4.6)	50.0 (15.2)	21.0 (6.4)	60.0 (18.3)
336	30.0 (9.1)	34.0 (10.4)	36.0 (11.0)	47.0 (14.3)	18.0 (5.5)	55.0 (16.8)	24.0 (7.3)	66.0 (20.1)
384	35.5 (10.8)	39.0 (11.9)	41.0 (12.5)	52.0 (15.8)	20.0 (6.1)	59.0 (18.0)	28.0 (8.5)	71.0 (21.6)
500	36.5 (11.1)	42.0 (12.8)	43.5 (13.3)	57.0 (17.4)	24.0 (7.3)	65.0 (19.8)	30.0 (9.1)	76.0 (23.2)
600	42.5 (13.0)	45.0 (13.7)	46.5 (14.2)	60.0 (18.3)	26.0 (7.9)	70.0 (21.3)	34.0 (10.4)	78.0 (23.8)
720	48.0 (14.6)	46.0 (14.0)	53.0 (16.2)	63.0 (19.2)	28.0 (8.5)	75.0 (22.9)	38.0 (11.6)	87.0 (26.5)

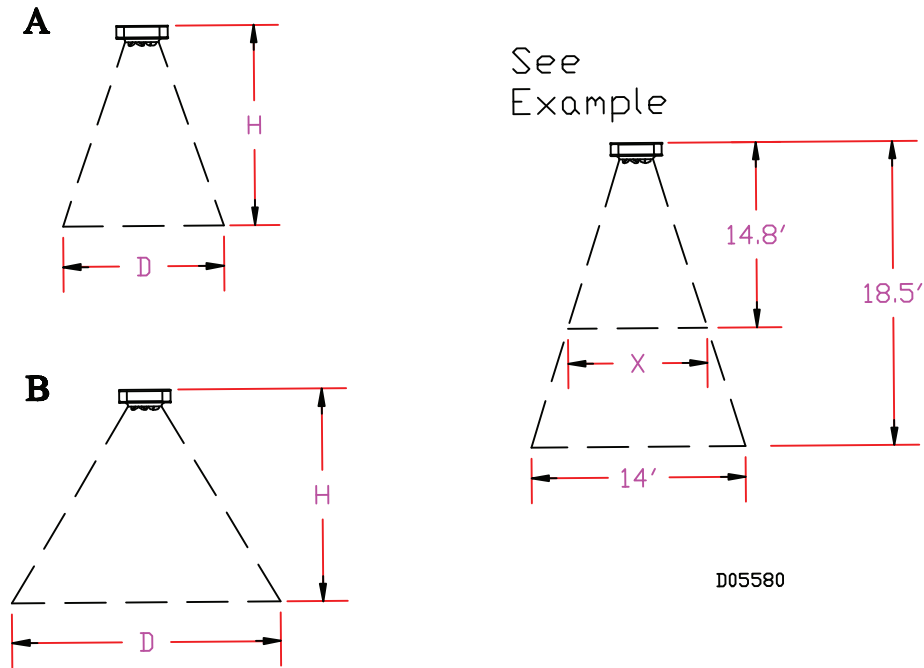

Figure 15.

Notes: To meet OSHA requirements, units mounted lower than 8 feet from the floor must be equipped with an OSHA fan guard.

Table 7. Mounting Height Correction Factors

Water	°F	150	160	170	180	190	200
Temperature	(°C)	(66)	(71)	(77)	(82)	(88)	(93)
Steam	PSI	-	-	-	-	-	-
Pressure	(kPa)	-	-	-	-	-	-
Correction Factor		1.32	1.27	1.23	1.18	1.14	1.09
Water	°F	210	219	227	239	250	259
Temperature	(°C)	(99)	(104)	(108)	(115)	(121)	(126)
Steam	PSI	-	2	5	10	15	20
Pressure	(kPa)	-	(13.8)	(34.5)	(68.9)	(103.4)	(137.9)
Correction Factor		1.05	1.00	0.97	0.94	0.89	0.86
Water	°F	267	280	287	298	307	320
Temperature	(°C)	(131)	(138)	(142)	(148)	(153)	(160)
Steam	PSI	25	35	40	50	60	75
Pressure	(kPa)	(172.4)	(241.3)	(275.8)	(344.7)	(413.6)	(517.1)
Correction Factor		0.83	0.80	0.76	0.73	0.70	0.69

Piping

To provide proper coil operation, follow all piping recommendations listed in this manual.

Threaded pipe headers are provided on all Vertical Units for piping connections. See [Figure 25](#). Connections are given in [Figure 18](#) and [Figure 19](#) and [Table 27](#) and [Table 28](#).

Follow standard practices and codes when installing the piping. Provide swing joints for expansion purposes, unions and shut-off valves for servicing purposes and as illustrated in [Figure 6](#) through [Figure 9](#), valves and traps for control purposes. Use 45 degree angle run-offs from all supply and return mains.

Dirt pockets should be the same pipe size as the return tapping of the unit heater. Also, pipe size in the branchoff should be the same size as the tapping in the traps. Beyond the trap, the return lateral pipe should be increased one size up to the return main.

Properly support all piping to unit!
Do not allow piping to place a strain on the coil or unit. Noise or coil failure may occur.

It is assumed that the type of system to be used has been selected by design engineer. The sketches shown are for different type of steam systems or hot water systems. For sizing of piping, traps, filter, etc., consult ASHRAE guides of the manufacturer's literature on these products.

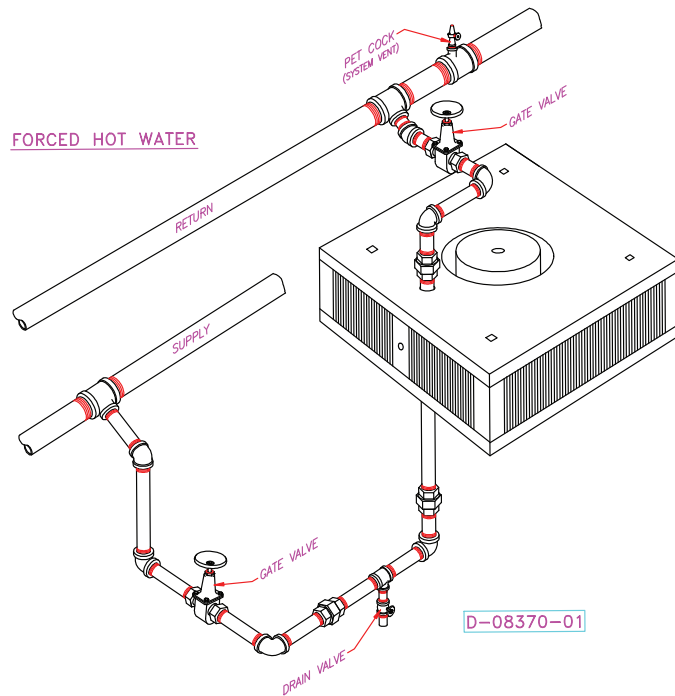

Figure 16.

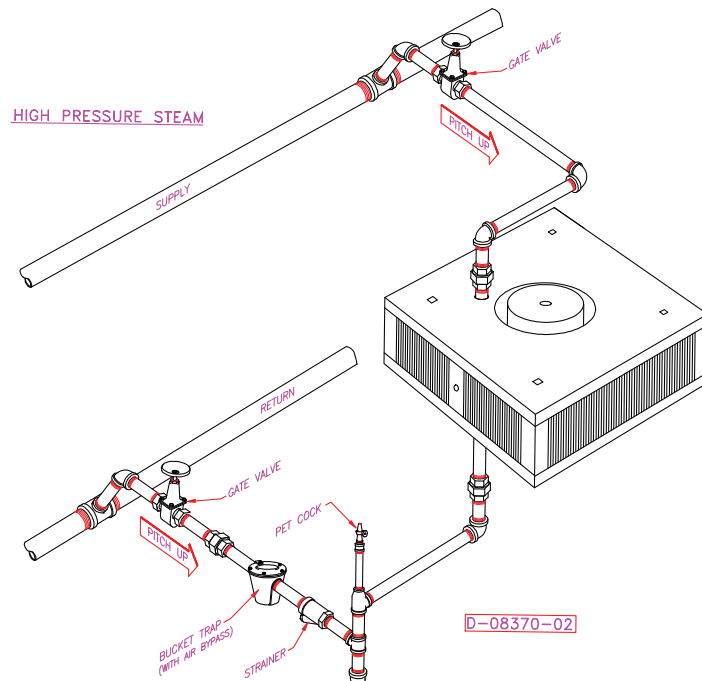

Figure 17.

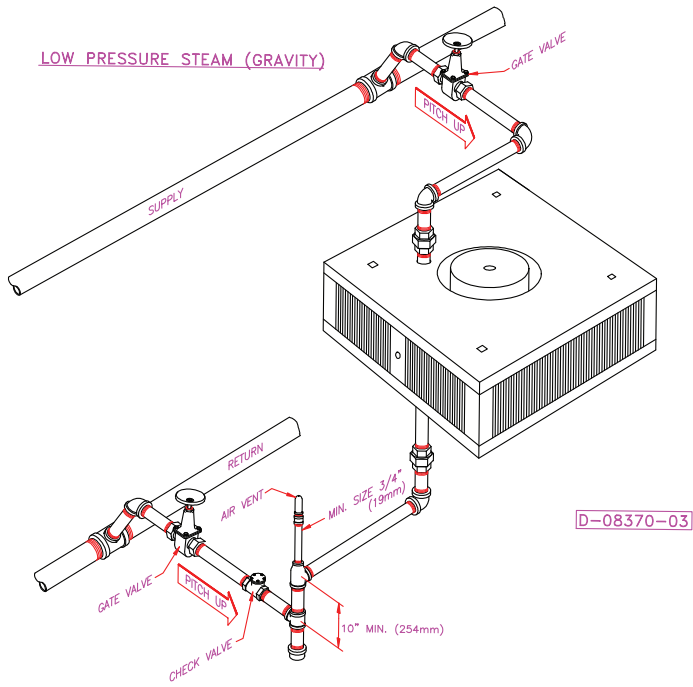

Figure 18.

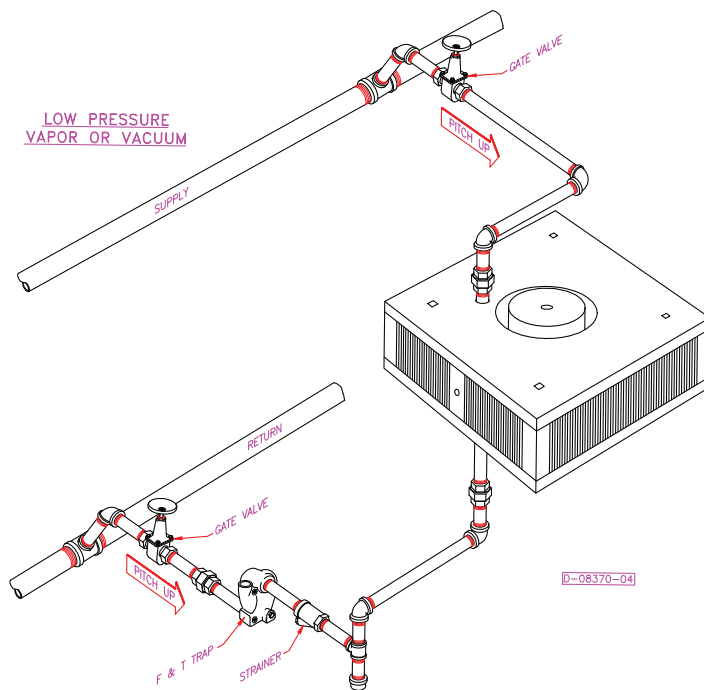

Figure 19.

Installation: S Type

Unit Mounting

WARNING Heavy Objects!

Ensure that all hardware used in the suspension of each unit heater is more than adequate for the job. Failure to do so may result in extensive property damage, severe personal injury or death.

WARNING Structural Integrity!

Make certain that the structure to which the heater is mounted is capable of supporting its weight. Under no circumstances must the gas lines, the venting system, or the electrical conduit be used to support the heater; or should any other objects (i.e. ladder, person) lean against the heater gas lines, venting system, electrical conduit for support. Failure to heed these warnings may result in property damage, personal injury, or death.

CAUTION Lifting/Suspension Methods!

Make certain that the lifting methods used to lift the heater and the method of suspension used in the field installation of the heater are capable of uniformly supporting the weight of the heater at all times. Failure to heed this warning may result in property damage or personal injury!

NOTICE Performance Failure!

Unit heaters must be hung level from side to side and from front to back. Failure to do so will result in poor performance and or premature failure of the unit.

Install unit heaters to meet Occupational Safety and Health Act (OSHA) and CSA requirements. Unit heaters mounted lower than 8 feet (2.4m) from the floor must be equipped with an OSHA fan guard.

Note: Units equipped with the motor mounted to the fan guard require two point suspension. Units equipped with a shelf mounted motor are required to be suspended

at four points. Refer to [Figure 20](#) and [Figure 21](#) for two point suspension and refer to [Figure 9](#) for four point suspension.

Nutserts are provided at the top of all units for suspension purposes. Support rods should support the total unit weight to assure that no strain is placed on supply and return piping. Provisions for removal of the unit from the suspension rods may be desirable for servicing purposes.

Units must hang level vertically and horizontally.

Provide sufficient clearance around units for maintenance purposes.

Isolators are not required but may be desirable for some applications. Refer to "Dimensional Data."

Piping

To provide proper coil operation, follow all piping recommendations listed in this manual.

See [Figure 13](#) through [Figure 17](#) for proper pipe connections.

Follow standard practices and codes when installing the piping. Provide swing joints for expansion purposes, unions and shut-off valves for servicing purposes and as illustrated in [Figure 13](#) through [Figure 17](#), valves and traps for control purposes. Use 45 degree angle run-offs from all supply and return mains.

Dirt pockets should be the same pipe size as the return tapping of the unit heater. Also, pipe size in the branchoff should be the same size as the tapping in the traps. Beyond the trap, the return lateral pipe should be increased one size up to the return main.

It is assumed that the design engineer has selected the type of system to be used. The sketches shown are for different types of steam systems or hot water systems. For sizing of piping, traps, filter, etc., consult ASHRAE guides of the manufacturer's literature on these products.

It is important that the system be kept clean. Care should be exercised that excessive joint materials or foreign substances be kept out of the system.

On steam systems it is recommended that the unit be installed level for proper condensate drainage. Swing joints should be used in piping, and pipes should be pitched down from units so that condensate can drain freely.

Fan Guard/Louver Installation

OSHA Fan Guard/Louver Cone Diffuser Installation Detail

⚠️ WARNING Hazardous Voltage

Do not mount either the Louver Cone Diffuser or OSHA Fan Guard while unit is in operation or severe personal injury may occur. Disconnect all power supplies to the unit before installing the Louver Cone Diffuser or OSHA Fan Guard.

The figures below show how both the OSHA Fan Guard and the Louver Cone Diffuser are installed on the Vertical Steam and Hot Water Unit Heater. [Figure 20](#) and [Figure 21](#) detail how the louver cone diffuser and OSHA guard are attached to the unit. [Figure 22](#) and [Figure 23](#) show full views of the vertical steam and hot water unit with a Louver Cone Diffuser and OSHA Fan Guard attached.

To meet CSA and OSHA requirements, units mounted below 8 feet (2.4 meters) must be equipped with an OSHA Fan Guard.

The same screws and washers are provided with both the OSHA fan guard and Louver Cone Diffuser. The screws and washers are used in conjunction with the Nutserts to support the wire guard or diffuser to the orifice panel (bottom of vertical unit).

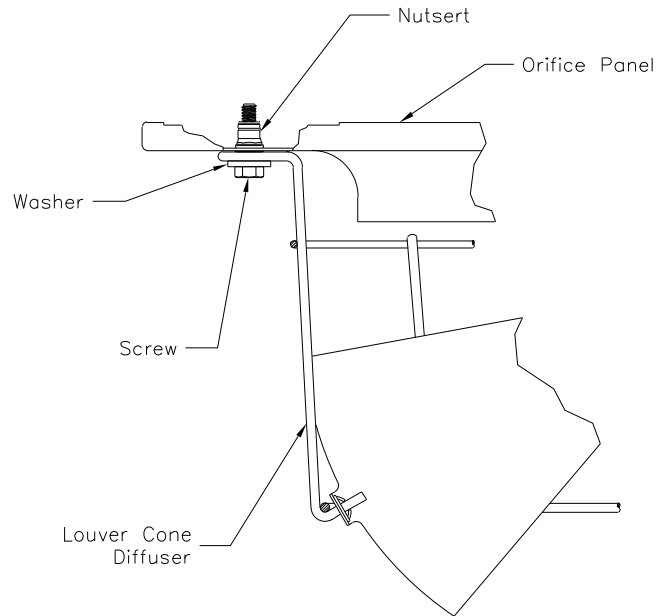

Figure 20. Louver Cone Diffuser

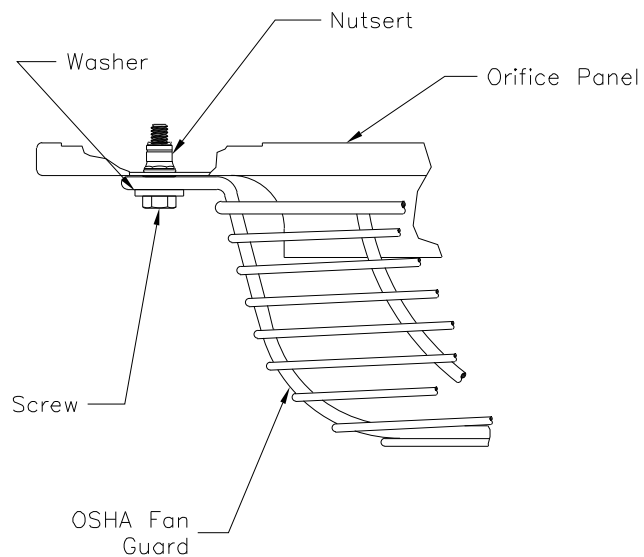

Figure 21. OSHA Fan Guard

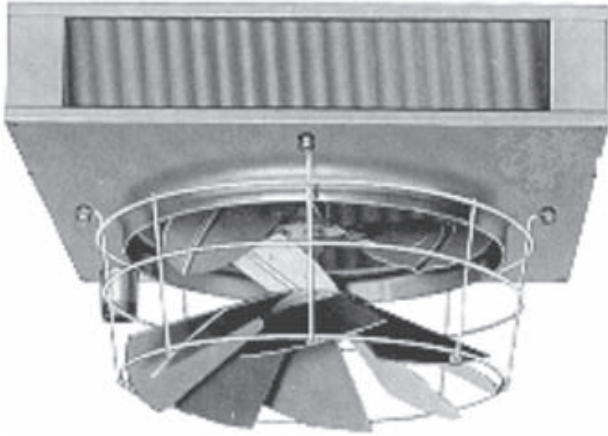

Figure 22. Vertical Unit with Louver Cone Diffuser



Figure 23. Vertical Unit with OSHA Fan Guard

Dimensional Data

Dimensional Data: P Model

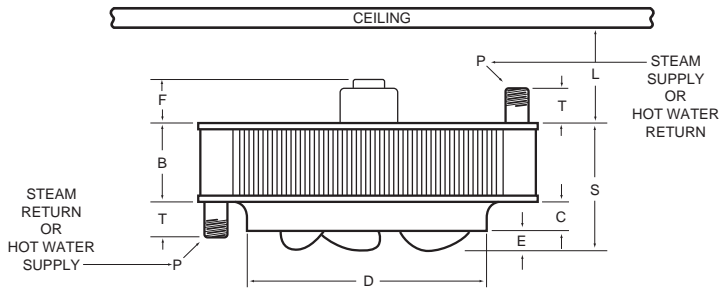
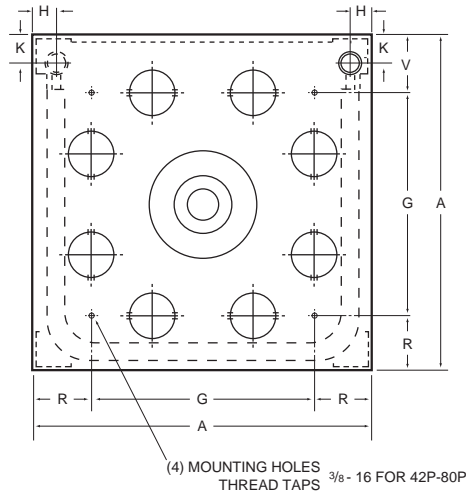

Figure 24. Models 42-80

Table 8. Roughing in Dimensional Data - Model Size 42-80

Unit Capacity (MBH)	Fan Dia.	A	B	C	D	E	F	G	H	K	L (Min.)	P (NPT)	R	S	T	U	V
042	11 1/4	18 1/4	4 5/8	1 1/4	11 3/4	3/4	4	11	1 3/8	1 7/8	7	1 1/2	3 5/8	6 5/8	2 3/4	11	3 5/8
064	13 1/2	21 1/4	4 5/8	1 5/8	14	1	4	14	1 3/8	1 7/8	7	1 1/2	3 5/8	7 1/8	2 3/4	14	3 5/8
080	13 1/2	21 1/4	6 1/8	1 5/8	14	1	3	14	1 3/8	1 7/8	7	1 1/2	3 5/8	8 5/8	2 3/4	14	3 5/8

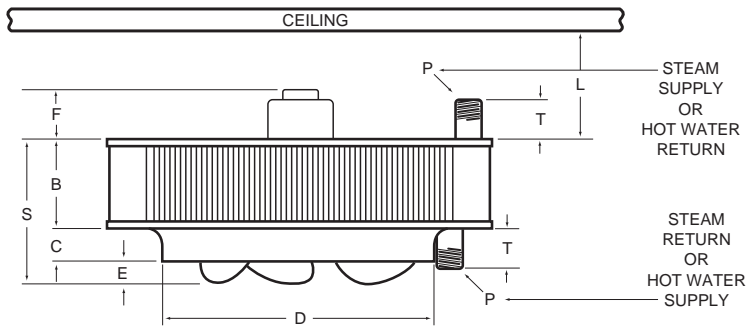
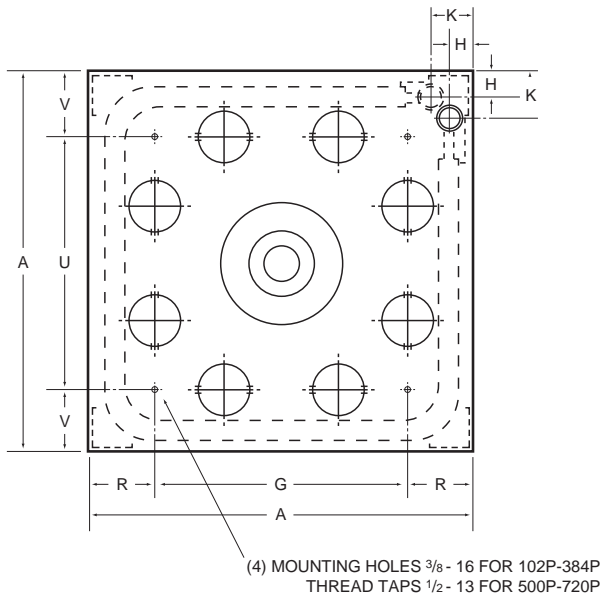

Figure 25. Models 102-720

Table 9. Roughing in Dimensional Data - Model Size 102-720

Unit Capacity (MBH)	Fan Dia.	A	B	C	D	E	F	G	H	K	L (Min.)	P (NPT)	R	S	T	U	V
102	16 3/4	25 1/4	6 1/8	2	17 1/2	1 1/8	3	17	1 3/8	2 3/4	7	1 1/2	4 1/8	9 1/8	2 3/4	17	4 1/8
122	16 3/4	25 1/4	6 1/8	2	17 1/2	1 3/4	3	17	1 3/8	2 3/4	7	1 1/2	4 1/8	9 3/4	2 3/4	17	4 1/8
146	19 3/4	29 1/2	6 1/8	2 3/8	20 5/8	1 1/4	4	20 1/2	1 3/4	3 1/2	7	2	4 1/2	9 5/8	2 3/4	20 1/2	4 1/2
166	19 3/4	29 1/2	6 1/8	2 3/8	20 5/8	1 3/4	4	20 1/2	1 3/4	3 1/2	7	2	4 1/2	10 1/8	2 3/4	20 1/2	4 1/2
202	19 3/4	29 1/2	7 5/8	2 3/8	20 5/8	2	4	20 1/2	1 3/4	3 1/2	7	2	4 1/2	12	2 3/4	20 1/2	4 1/2
252	25 1/4	37 1/2	7 5/8	3	26 3/8	1 3/2	3 1/2	28	1 3/4	3 1/2	7	2	4 3/4	11 5/8	2 3/4	18	9 3/4
280	25 1/4	37 1/2	7 5/8	3	26 3/8	1 1/4	3 1/2	28	1 3/4	3 1/2	7	2	4 3/4	11 3/4	2 3/4	18	9 3/4
336	25 1/4	37 1/2	7 5/8	3	26 3/8	2 1/8	4	28	1 3/4	3 1/2	7	2	4 3/4	12 3/4	2 3/4	18	9 3/4
384	25 1/4	37 1/2	9 1/8	3	26 3/8	2 3/2	3 1/2	28	1 3/4	3 1/2	7	2	4 3/4	14 1/8	2 3/4	18	9 3/4
500	30 1/2	42	9 1/8	3 1/2	31 1/4	1 5/8	3	30	2 1/4	4 1/4	7	2 1/2	6	14 1/4	3	30	6
600	30 1/2	42	12 1/8	3 1/2	31 1/4	2 1/8	3	30	2 1/4	4 1/4	7	2 1/2	6	17 3/4	3	30	6
720	30 1/2	42	13 5/8	3 1/2	31 1/4	3	4	30	2 1/4	4 1/4	7	2 1/2	6	20 1/4	3	30	6

Dimensional Data: S Model

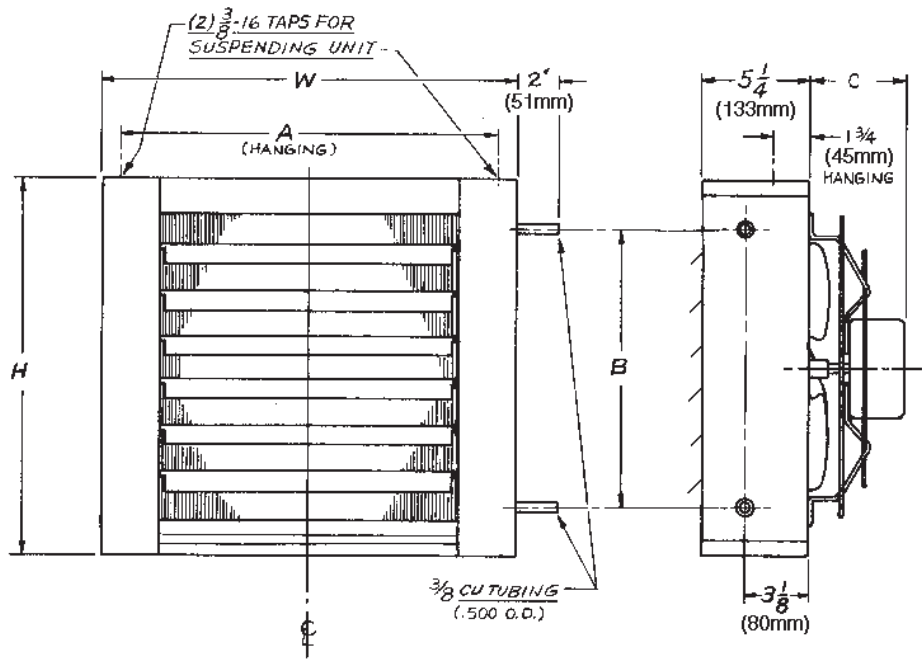

Figure 26. Serpentine Type Models A08, A18, A25, A36

Note: Motors are totally enclosed, thermally protected, sleeve bearing, with 4" (w) x 2" (h) conduit connection boxes. 3/8-16 nutserts are attached to enclosure for balanced hanging.

Table 10. Table 3- Serpentine Models

MODEL	H inches (mm)	W inches (mm)	A inches (mm)	B inches (mm)	C inches (mm)	NO. OF LOUVERS	NOM. FAN DIAM. inches (mm)	APPROX. SHIP WT. lbs. (kg)
A08	16 (406)	18 (457)	16 7/32 (412)	11 1/4 (286)	4 1/4 (108)	5	9 (229)	22 (10.0)
A18	16 (406)	18 (457)	16 7/32 (412)	11 1/4 (286)	4 1/4 (108)	5	10 (254)	24 (10.9)
A25	16 (406)	18 (457)	16 7/32 (412)	11 1/4 (286)	4 1/4 (108)	5	10 (254)	25 (11.3)
A36	18 1/2 (470)	20 1/2 (521)	18 22/32 (475)	13 3/4 (349)	5 1/8 (130)	6	12 (305)	31 (14.0)

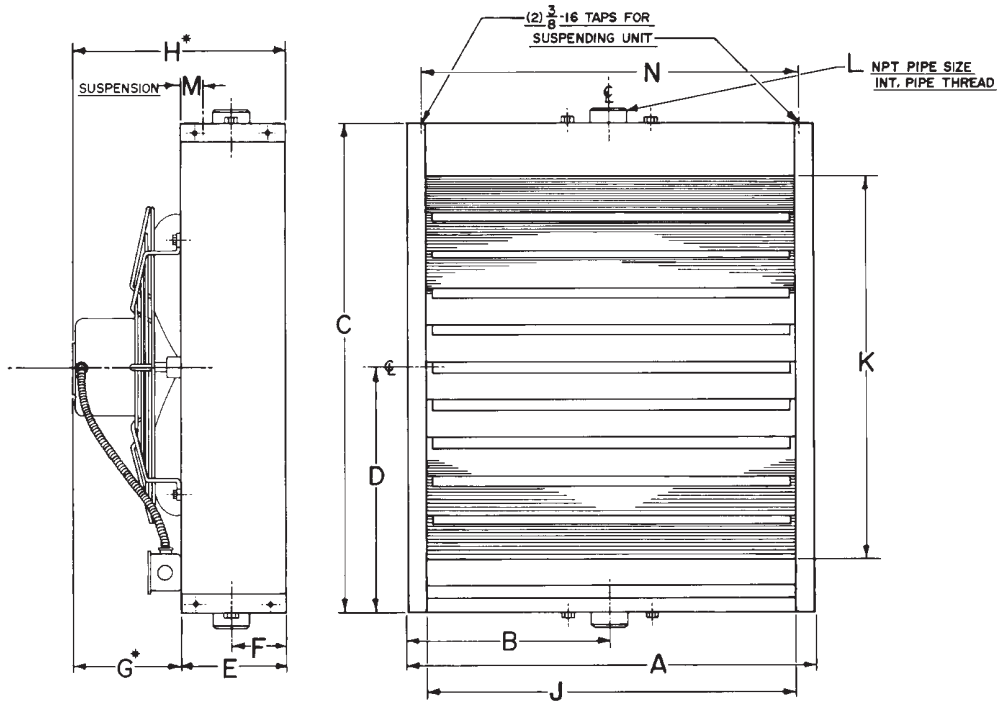

Figure 27. Header Type Models 18 thru 360

Note: Motors are totally enclosed, thermally protected, sleeve bearing, with 4" (w) x 2" (h) conduit connection boxes. 3/8-16 nutserts are attached to enclosure for balanced hanging.



Dimensional Data

Table 11. Header Models

MODEL	A inches (mm)	B inches (mm)	C inches (mm)	D inches (mm)	E inches (mm)	F inches (mm)	G* inches (mm)	H* inches (mm)	J inches (mm)	K inches (mm)	L inches (mm)	M inches (mm)	N inches (mm)	NO. OF LOU- VERS	NOM. FAN DIAM. inches (mm)	APPROX. SHIP WT. lbs. (kg)
18	14 5/8 (371)	7 5/16 (186)	15 (381)	7 1/2 (191)	6 1/8 (156)	2 15/16 (75)	3 1/4 (83)	9 3/8 (238)	12 1/4 (311)	9 1/2 (241)	1 1/4 (32)	2 1/4 (57)	12 7/8 (327)	4	9 (229)	26 (11.8)
24 36	14 5/8 (371)	7 5/16 (186)	18 (457)	9 (229)	6 1/8 (156)	2 15/16 (75)	3 1/4 (83)	9 3/8 (238)	12 1/4 (311)	12 1/2 (318)	1 1/4 (32)	2 1/4 (57)	12 7/8 (327)	5	10 (254)	30 (13.6)
48 60	17 1/8 (435)	8 9/16 (217)	20 1/2 (521)	10 1/4 (260)	5 7/8 (149)	2 15/16 (75)	5 1/16 (129)	10 15/16 (278)	14 3/4 (375)	15 (381)	1 1/4 (32)	1 3/4 (44)	15 3/8 (391)	6	12 (305)	41 (18.6)
72	18 3/8 (467)	9 3/16 (233)	21 3/4 (552)	10 7/8 (276)	6 (152)	2 15/16 (75)	5 1/16 (129)	11 1/16 (281)	16 (406)	16 1/4 (413)	1 1/4 (32)	1 3/4 (44)	16 5/8 (422)	7	14 (356)	44 (19.9)
84	20 7/8 (530)	10 7/16 (265)	24 1/4 (616)	12 1/8 (308)	6 1/8 (156)	2 15/16 (75)	5 11/16 (144)	11 13/16 (300)	18 1/2 (470)	18 3/4 (476)	1 1/4 (32)	1 3/4 (44)	19 1/8 (486)	8	14 (356)	47 (21.3)
96 108	19 5/8 (498)	9 13/16 (249)	24 (610)	12 (305)	6 5/16 (160)	3 3/16 (81)	7 1/2 (191)	13 13/16 (351)	17 1/4 (438)	17 1/2 (445)	1 1/2 (38)	1 3/4 (44)	17 7/8 (454)	8	16 (406)	49 (22.2)
120	20 7/8 (530)	10 7/16 (265)	25 1/4 (641)	12 5/8 (321)	6 5/16 (160)	3 3/16 (81)	6 11/16 (170)	13 (330)	18 1/2 (470)	18 3/4 (476)	1 1/2 (38)	1 3/4 (44)	19 1/8 (486)	8	18 (457)	59 (26.7)
132 144	23 3/8 (594)	11 11/16 (297)	27 3/4 (705)	13 7/8 (352)	6 5/16 (160)	3 3/16 (81)	7 5/8 (194)	14 (356)	21 (533)	21 1/4 (540)	1 1/2 (38)	1 3/4 (44)	21 5/8 (549)	9	18 (457)	74 (33.5)
156	23 3/8 (594)	11 11/16 (297)	27 3/4 (705)	13 7/8 (352)	6 5/16 (160)	3 3/16 (81)	7 7/16 (189)	13 3/4 (349)	21 (533)	21 1/4 (540)	1 1/2 (38)	1 3/4 (44)	21 5/8 (549)	9	18 (457)	74 (33.5)
180 204	24 5/8 (625)	12 5/16 (313)	29 (737)	14 1/2 (368)	6 3/8 (162)	3 3/16 (81)	7 7/16 (189)	13 3/4 (349)	22 1/4 (565)	22 1/2 (572)	1 1/2 (38)	1 3/4 (44)	22 7/8 (581)	9	18 (457)	90 (40.8)
240	27 7/8 (708)	13 15/16 (354)	30 1/4 (768)	15 1/8 (384)	8 1/8 (206)	3 3/16 (81)	5 7/8 (149)	14 (356)	25 1/2 (648)	23 3/4 (603)	2 (51)	1 3/4 (44)	26 1/8 (664)	10	20 (508)	125 (57)
280	27 7/8 (708)	13 15/16 (354)	30 1/4 (768)	15 1/8 (384)	8 1/8 (206)	3 3/16 (81)	9-5/8 (244)	17 3/4 (451)	25 1/2 (648)	23 3/4 (603)	2 (51)	1 3/4 (44)	26 1/8 (664)	10	20 (508)	118 (53)
300 360	33 3/8 (848)	16 11/16 (424)	37 3/4 (959)	18 7/8 (479)	9 (229)	3 3/16 (81)	9 5/8 (244)	18 5/8 (473)	31 (787)	31 1/4 (794)	2 (51)	1 3/4 (44)	31 5/8 (803)	13	24 (610)	154 (69.8)

* Applies to standard motor with standard fan guard. When optional motors or OSHA fan guards are requested, dimensions will change according to the substitutions made.

NOTES

1. Standard motor and standard guard shown.
2. Optional OSHA guards available for all units with 1 phase motor. Models A08 - A36 and O18 - O48 OSHA guards standard.
3. All 3 phase and explosion proof motors are shelf mounted.



Technical Data

Technical Data: S Models

The performance data listed in Table 11 includes sound ratings. The ratings provide a guide in determining the acceptable degree of loudness in particular occupancy situations.

Certain general rules apply to specific selection of unit heaters with regard to degree of quietness (or loudness);

- The greater the fan diameter, the higher the sound level.
- The higher the motor RPM, the higher the sound level. Note that on most units the lower the speed mode results in lowering the sound rating one increment.
- Selecting a larger number of smaller units generally results in lower overall noise levels than fewer large units.

All horizontal steam and hot water unit heater motors, whether fan guard or shelf-mounted, are isolated from the mechanical mount by resilient isolators. This mounting along with balanced fan blades and excellent overall construction integrity, assures you the utmost in quiet operation.

The following table outlines SOUND RATING for various applications. The lower the number, the quieter the unit and the lower the sound requirement.

CATEGORY OF AREA	SOUND RATING
apartment, assembly hall, classrooms, churches, courtrooms, executive offices, hospitals, libraries, museums, theatres	I
dining rooms, general offices, recreation areas, small retail stores	II
restaurants, banks, cafeterias, department stores, public buildings, service stations	III
gymnasiums, health clubs, laundromats, supermarkets	IV
garages, small machine shops, light manufacturing	V
Factories, foundries, steel mills	III-VII*

*Depending on specific use in these facilities, size of operation, etc.

Table 12. Corrections When Using Glycol Solution in System

	Propylene Glycol
Heat transfer @ 180°F (82°C) with no increase inflow rate	20% solution .97*
	50% solution .90*
G.P.M. Req'd. @ 180°F (82°C), 20°F (11°C) Δ t (no correction to pump curve)	1.10%*
Pump Head Req'd. @ 180°F (82°C) w/increase in G.P.M.	1.23%*
Specify gravity (water = 1.0)	1.045-1.055*
Pounds/Gallons @ 60°F (16°C) (water = 8.3453 Pound/Gallon)	8.77
pH @ 50% by volume	9.5
Freezing Point by volume	55% -
	50% -28°F (-33°C)
	40% -13°F (-25°C)
	30% + 4°F (-16°C)
	20% +17°F (- 8°C)

*Compared to water.

Table 13. Approximate factors at varying altitudes

Altitude	Factor
Sea level - 1000 ft. (305m)	1.00
1000 ft. - 3000 ft. (915m)	.958
3000 ft. - 5000 ft. (1524m)	.929
5000 ft. - 7000 ft. (2134m)	.900
7000 ft. - 10000 ft. (3048m)	.871



Technical Data

Technical Data: P Model

The performance data listed in [Table 13](#), [Table 14](#), and [Table 15](#) include sound ratings. The ratings provide a guide in determining the acceptable degree of loudness in particular occupancy situations.

Certain general rules apply to specific selection of unit heaters with regard to degree of quietness (or loudness);

- The greater the fan diameter, the higher the sound level.
- The higher the motor RPM, the higher the sound level. Note that on most units the lower the speed mode results in lowering the sound rating one increment.
- Selecting a larger number of smaller units generally results in lower overall noise levels than fewer large units.

All vertical steam and hot water unit heater motors, whether fan guard or shelf-mounted, are isolated from the mechanical mount by resilient isolators. This mounting along with balanced fan blades and excellent overall construction integrity, assures you the utmost in quiet operation.

The following table outlines sound ratings for various applications. The lower the number, the quieter the unit and the lower the sound requirement.

Category of Area	Sound Rating
apartment, assembly hall, classrooms, churches, courtrooms, executive offices, hospitals, libraries, museums, theatres	I
dining rooms, general offices, recreation areas, small retail stores	II
restaurants, banks, cafeterias, department stores, public buildings, service stations	III
gymnasiums, health clubs, laundromats, supermarkets	IV
garages, small machine shops, light manufacturing	V
factories, foundries, steel mills	III-VII*

* Depending on specific use in these facilities, size of operation, etc.

Table 14. Corrections When Using Glycol Solution in System

	Propylene Glycol	
Heat transfer @ 180°F with no increase inflow rate	20% solution	.97*
	50% solution	.90*
G.P.M. Req'd. @ 180°F, 20°F Δ t (no correction to pump curve)		1.10%*
Pump Head Req'd. @ 180°F w/ increase in G.P.M.		1.23%*
Specify gravity (water = 1.0)		1.045-1.055*
Pounds/Gallons @ 60°F (water = 8.3453 Pound/Gallon)		8.77
pH @ 50% by volume		9.5
Freezing Point by volume	55%	-
	50%	-28°F
	40%	-13°F
	30%	+ 4°F
	20%	+17°F

*Compared to water.

Table 15. Approximate factors at varying altitudes

Altitude	Factor
Sea level - 1000 ft.	1.00
1000 ft. - 3000 ft.	.958
3000 ft. - 5000 ft.	.929
5000 ft. - 7000 ft.	.900
7000 ft. - 10000 ft.	.871

Options

Options: S Models

Variable Speed Control 115 Volt Only (optional)

The solid state speed controller may be installed at any convenient location and is suitable for surface or flush type mounting. A Standard electrical single or double gang wall box is recommended as in [Figure 28](#).

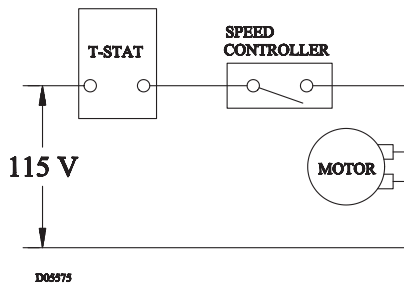

Figure 28. Wiring Diagram of Speed Control Installation

Installation Procedure:

1. Attach the control's leads to the electrical leads in the control box using wire nuts. The speed control is to be wired in series with the motor. See wiring diagram in [Figure 28](#).
2. Make certain wire nuts are tight with no copper wire being exposed.
3. Place wires and wire nuts back into box allowing room for the control to fit in box also.
4. Mount speed control to box using number 6 flathead screws provided.

Setting the Control:

1. Turn the control shaft fully clockwise. If the motor is not running at the desired low speed, adjust the trim on the face of the control for low speed setting using a small screwdriver.
2. Rotate the control shaft counter clockwise. The speed will increase smoothly from minimum to maximum and then switch off.

3. Mount face plate with screw provided and attach control knob.

Strap-On Water Control

A SPDT strap-on type hot water control with 100° to 240°F (38 to 116°C) rated at 10 amps at 120V is also available. Control can be used for direct or reverse acting applications as high or low limit.

Steam Pressure Control

SPDT switch opens on a rise in pressure. Control is automatically reset, has a range of 0 to 15 PSIG (0 to 103 kPa) and has an adjustable differential. **Other actions, ranges, circuits and manual reset models are available on request.**

Horizontal and Vertical Louvers

Horizontal louvers are standard on all models. Vertical louvers are an optional accessory on all models. Vertical louvers are installed on built to order units or shipped loose for field installation.

Thermostats

Line voltage wall thermostats are in stock for immediate shipment. All models are SPST with bimetal thermometer, knob-type set point adjustment, 40 to 90°F (5 to 30°C) range and selector switches.

Standard duty models with "off-auto" and "auto-off-fan" and a heavy duty model with "auto-off-fan" switching are available. Other models available on request. Plastic tamperproof one size fits all thermostat guards are also available.

Manual Starters

Single and three-phase models are available. Standard models are single-speed, toggle-operated, NEMA Type 1 and are surface-mounted.

Wall Mounted Speed Controllers

Units with standard motors up to Model 108 (115/1/60) can be operated at reduced speeds by addition of optional speed controller. Controller is 5 amps, pre-set at factory for maximum and minimum speeds, with intermediate speeds infinitely controllable. All 1/3, 1/2 HP and 230V motors operate only at rated speed and CFM - See Tables.

CAUTION

When using electrical accessories, always refer to the accessory manufacturer's installation manual for proper use, location and wiring instructions.

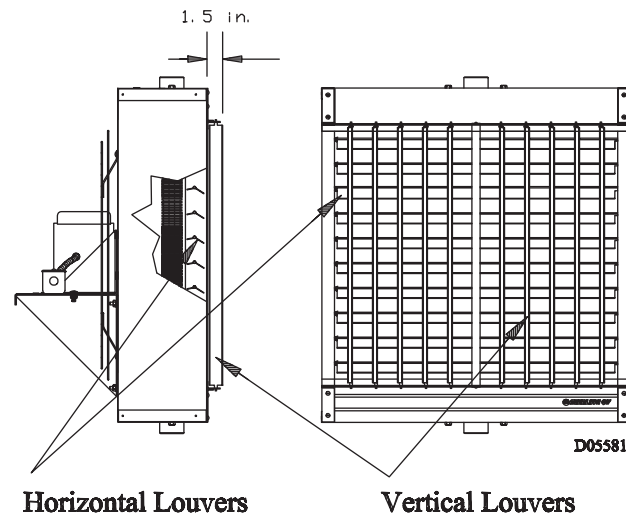

Figure 29. Horizontal and Vertical Louver Mounting

Options: P Models

Variable Speed Control 115 Volt Only (optional)

The solid state speed controller may be installed at any convenient location and is suitable for surface or flush type mounting. A standard electrical single or double gang wall box is recommended as in [Figure 30](#).

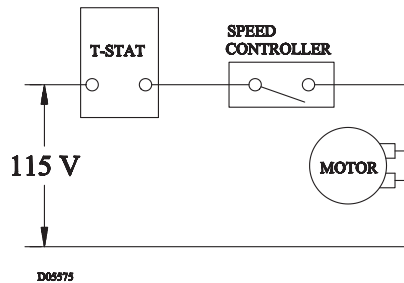

Figure 30. Wiring Diagram of Speed Control Installation

Installation Procedure:

1. Attach the control's leads to the electrical leads in the control box using wire nuts. The speed control is to be wired in series with the motor. See wiring diagram in [Figure 30](#).
2. Make certain wire nuts are tight with no copper wire being exposed.
3. Place wires and wire nuts back into box allowing room for the control to fit in box also.
4. Mount speed control to box using number 6 flathead screws provided.

Setting the Control:

1. Turn the control shaft fully clockwise. If the motor is not running at the desired low speed, adjust the trim on the face of the control for low speed setting using a small screwdriver.
2. Rotate the control shaft counter clockwise. The speed will increase smoothly from minimum to maximum and then switch off.

Vertical Louver Cone Diffuser (optional)

Rubber mounts and mounting nuts and bolts are provided with each louver cone diffuser. Attach the

diffuser to the bottom of the unit heater as shown in [Figure 51](#). Mounting holes are provided in the unit base plate.

Adjust the diffuser to provide the desired air pattern.

Strap-On Water Control

A SPDT strap-on type hot water control with 100° to 240°F (38 to 116°C) rated at 10 amps at 120V is also available. Control can be used for direct or reverse acting applications as high or low limit.

Steam Pressure Control

SPDT switch opens on a rise in pressure. Control is automatically reset, has a range of 0 to 15 PSIG (0 to 103 kPa) and has an adjustable differential. **Other actions, ranges, circuits and manual reset models are available on request.**

Thermostats

Line voltage wall thermostats are in stock for immediate shipment. All models are SPST with bimetal thermometer, knob-type set point adjustment, 40 to 90°F (5 to 30°C) range and selector switches. Standard duty models with "off-auto" and a heavy duty model with "auto-offfan" switching are available. Other models available on request. Plastic tamperproof one size fits all thermostat guards are also available.

Wall Mounted Speed Controllers

Motors up to and including 1/8 HP (115V) can be operated at reduced speeds by addition of optional speed controller. Controller is 5 amps, pre-set at factory for maximum and minimum speeds, with intermediate

speeds indefinitely controllable. All 1/3, 1/2 HP and 230V motors operate only at rated speed and CFM - See Charts.

Manual Starters

Single and three-phase models are available. Standard models are single-speed, toggle-operated, NEMA Type 1 and are surface-mounted.

NOTICE

When using electrical accessories, always refer to the accessory manufacturer's installation manual for proper use, location and wiring instructions.

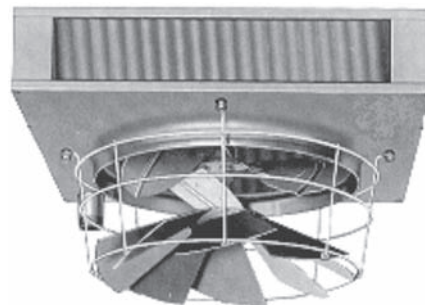

Figure 31. Louver Cone Diffuser Attached to Vertical Unit Heater



Electrical Connections

Electrical Connections: P Model

⚠️ WARNING Hazardous Voltage

Disconnect all electric power including remote disconnects before servicing. Failure to disconnect power before servicing can cause severe personal injury or death.

⚠️ WARNING Hazardous Voltage

Do not use any tools (i.e. screwdriver, pliers, etc.) across the terminals to check for power. Use a voltmeter. Failure to disconnect power before servicing can cause severe personal injury or death.

Standard units are shipped for use on 115 volt, 60 hertz single phase electric power. The motor nameplate and electrical rating on the transformer should be checked before energizing the unit heater electrical system. All external wiring must conform to ANSI/NFPA No. 70-2002, National Electrical Code (or the latest edition) and applicable current local codes; in Canada, to the Canadian Electrical Code, Part 1 CSA Standard C22.1.

It is recommended that the electrical power supply to each unit heater be provided by a separate, fused and permanently live electrical circuit. A disconnect switch of suitable electrical rating for each unit heater should be located as close to the controls as possible. Each unit heater must be electrically grounded in accordance with National Electric Code, ANSI/NFPA No. 70-2002 (or the latest edition of) or CSA Standard C22.1. Sample wiring connections are depicted in [Figure 38](#) through [Figure 40](#).

Operation

Most basic unit heater systems are controlled by a room thermostat. Locate thermostat on inner wall or column so that optimum control could be obtained for that area. Set thermostat for desired temperature.

On steam systems a low limit may be used to prevent fan from blowing

cold air unless the heater has steam passing through the coil.

Small hot water systems could have the circulating pump controlled directly by the room thermostat. On large systems, zone valves could be used to control the individual unit heater where constant water circulation is used on the main system.

A louvered cone air diffuser is readily available as an optional accessory for vertical unit heaters. See catalog for details.

Thermostat Wiring and Location

Note: *The thermostat must be mounted on a vertical vibration-free surface free from air currents and in accordance with the furnished instructions.*

Mount the thermostat approximately 5 feet (1.5 m) above the floor in an area where it will be exposed to a free circulation of average temperature air. Always refer to the thermostat instructions as well as our unit wiring diagram and wire accordingly. Avoid mounting the thermostat in the following locations:

1. Cold areas - Outside walls or areas where drafts may affect the operation of the control.
2. Hot areas - Areas where the sun's rays, radiation, or warm air currents may affect control operation.
3. Dead areas - Areas where air cannot circulate freely, such as behind doors or in corners.

Note: *For all wiring connections, refer to the wiring diagram on the motor nameplate. Should any original wire supplied with the heater have to be replaced, it must be replaced with wiring material having a temperature rating of at least 105° C.*

Motors

The standard 115/1/60 motors provided on Vertical Unit Heaters are totally enclosed, Class "B" insulated and have built-in thermal overload protection.

Vertical Units 42 through 80 use sleeve type bearings. Vertical Units 122 through 280 use permanent split capacitor motors with ball bearings.

All sleeve bearing motors have oil holes to allow lubrication. Ball bearing motors are permanently lubricated although some three phase or special motors have removable plugs which will allow field installation of grease fittings.

The standard 42 through 102 motors can be converted to variable speed operation with the addition of the solid state speed control.

See [Figure 32](#) through [Figure 37](#) for typical wiring diagrams.

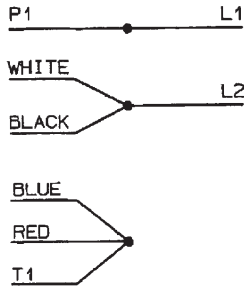

Figure 32. Fan Motor Connections Low Voltage with Protector Select Rotation (CCW shown)(Marathon) For CW Rotation Interchange (Red and black lead)

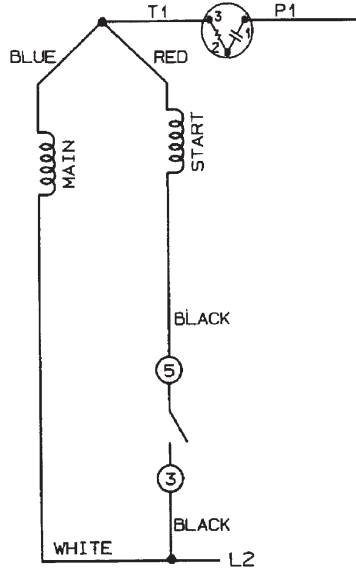
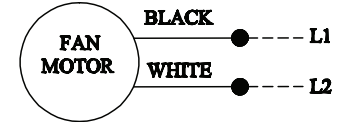

Figure 34. Fan Motor Connections Low Voltage CCW Internal (Marathon)

Fan Motor Connections 115/1/60 Constant Speed, Two Lead (GE, Marathon, Universal)



D05577

Figure 35. Fan Motor Connections 115/1/60 Constant Speed, Two Lead (GE, Marathon, Universal)

Fan Motor Connections 3 Phase Wiring

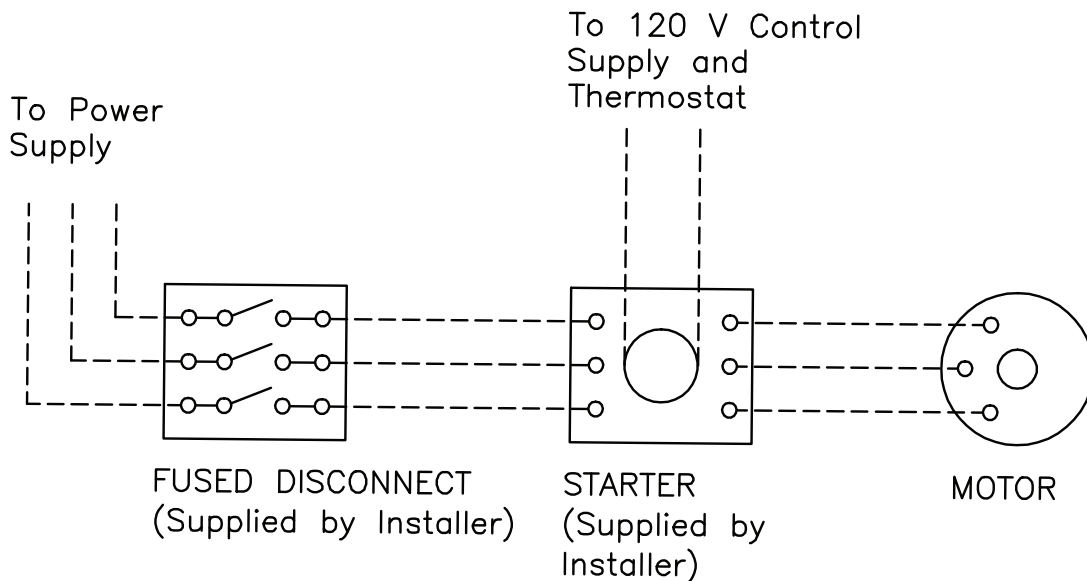

D05576

Figure 33.

Wiring Installation: P Model

Notice

1. When using a speed controller, always locate the thermostat between the speed controller and the line, not between the motor and the controller.
2. For internal wiring and overload protection on all starters, consult the control manufacturer for details.
3. When using thermostatic control with a manual starter, be sure that the electrical rating of the thermostat is sufficient to carry the motor current.

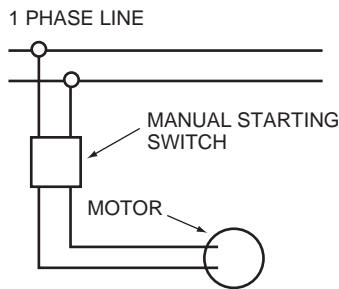

MANUAL CONTROL WITH SINGLE PHASE MOTOR

Figure 36.

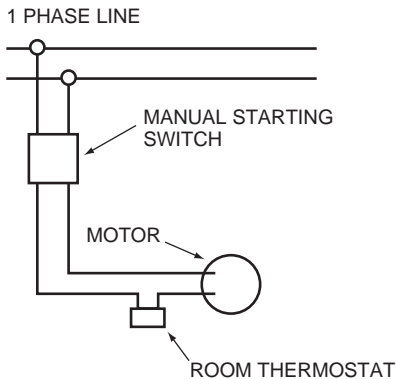

THERMOSTATIC CONTROL WITH MANUAL STARTER

Figure 37.

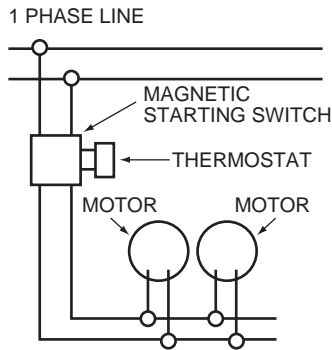

THERMOSTATIC CONTROL USING MAGNETIC STARTER OPERATING SEVERAL UNITS

Figure 38.

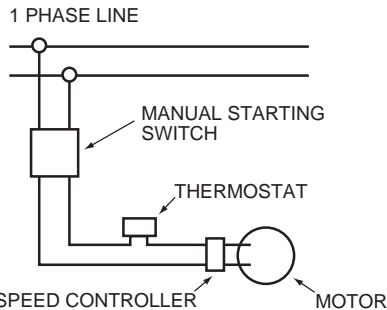

SPEED CONTROLLER WITH MANUAL STARTING SWITCH

Figure 39.

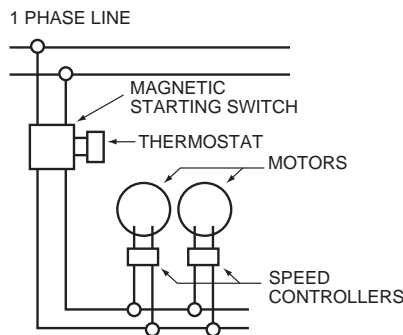

SPEED CONTROLLERS WITH MAGNETIC STARTING SWITCH FOR OPERATING SEVERAL UNITS

Figure 40.

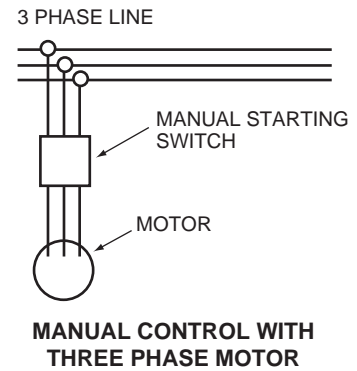

MANUAL CONTROL WITH THREE PHASE MOTOR

Figure 41.

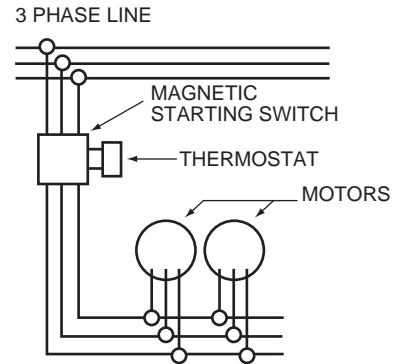

THERMOSTATIC CONTROL OF SEVERAL THREE PHASE UNITS

Figure 42.

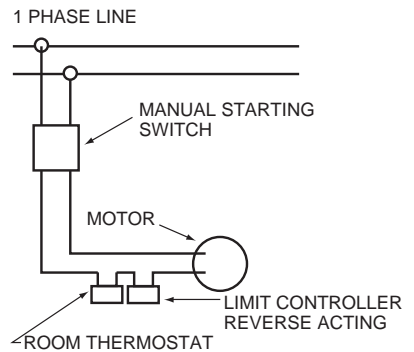

THERMOSTATIC CONTROL WITH ACTING LIMIT CONTROLLER AND MANUAL STARTER

Figure 43.

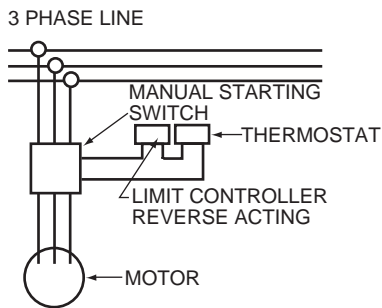

MANUAL CONTROL WITH THREE PHASE MOTOR

Figure 44.

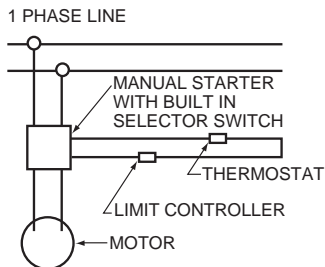

THREE POSITION SELECTOR SWITCH BUILT INTO MAGNETIC STARTER FOR MANUAL OR THERMOSTATIC CONTROL

Figure 45.

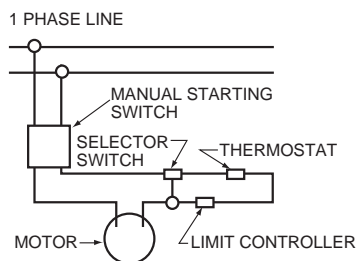

THREE POSITION SELECTOR SWITCH USED FOR EITHER MANUAL OR THERMOSTATIC CONTROL

Figure 46.

Electrical Connections: S Model

⚠ WARNING Hazardous Voltage

Disconnect all electric power including remote disconnects before servicing. Failure to disconnect power before servicing can cause severe personal injury or death.

⚠ WARNING Hazardous Voltage

Do not use any tools (i.e. screwdriver, pliers, etc.) across the terminals to check for power. Use a voltmeter. Failure to disconnect power before servicing can cause severe personal injury or death.

Standard units are shipped for use on 115 volt, 60 hertz single phase electric power. The motor nameplate and electrical rating on the transformer should be checked before energizing the unit heater electrical system. All external wiring must conform to ANSI/NFPA No. 70-2002, National Electrical Code (or the latest edition) and applicable current local codes; in Canada, to the Canadian Electrical Code, Part 1 CSA Standard C22.1.

It is recommended that the electrical power supply to each unit heater be provided by a separate, fused and permanently live electrical circuit. A disconnect switch of suitable electrical rating for each unit heater should be located as close to the controls as possible. Each unit heater must be electrically grounded in accordance with National Electric Code, ANSI/NFPA No. 70-2002 (or the latest edition) or CSA Standard C22.1. Sample wiring connections are depicted in [Figure 49](#) through [Figure 57](#).

Operation

Most basic unit heater systems are controlled by a room thermostat. Locate thermostat on inner wall or column so that optimum control can be obtained for that area. Set thermostat for desired temperature.

On steam systems a low limit may be used to prevent fan from blowing cold air unless the heater has steam passing through the coil.

Small hot water systems could have the circulating pump controlled directly by the room thermostat. On large systems, zone valves could be used to control the individual unit heater where constant water circulation is used on the main system.

Horizontal louvers are standard equipment on horizontal unit heaters, vertical louvers are available as an optional accessory.

Thermostat Wiring and Location

Note: *The thermostat must be mounted on a vertical vibration-free surface free from air currents and in accordance with the furnished instructions.*

Mount the thermostat approximately 5 feet (1.5 m) above the floor in an area where it will be exposed to a free circulation of average temperature air. Always refer to the thermostat instructions as well as our unit wiring diagram and wire accordingly. Avoid mounting the thermostat in the following locations:

1. Cold areas - Outside walls or areas where drafts may affect the operation of the control.
2. Hot areas - Areas where the sun's rays, radiation, or warm air currents may affect control operation.
3. Dead areas - Areas where air cannot circulate freely, such as behind doors or in corners.

Note: *For all wiring connections, refer to the wiring diagram on the motor nameplate. Should any original wire supplied with the heater have to be replaced, it must be replaced with wiring material having a temperature rating of at least 105° C.*

Wiring Installation: S Model

Notice

1. When using a speed controller, always locate the thermostat between the speed controller and the line, not between the motor and the controller.
2. For internal wiring and overload protection on all starters, consult the control manufacturer for details.
3. When using thermostatic control with a manual starter, be sure that the electrical rating of the thermostat is sufficient to carry the motor current.

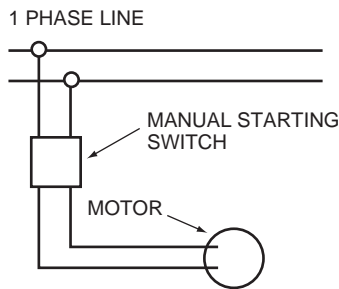

MANUAL CONTROL WITH SINGLE PHASE MOTOR

Figure 47.

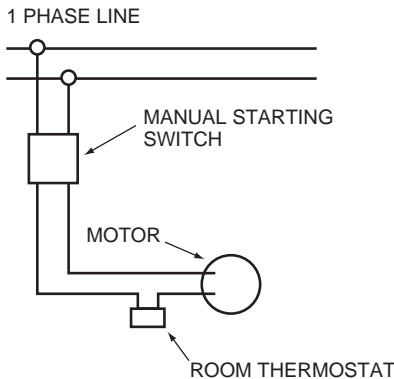

THERMOSTATIC CONTROL WITH MANUAL STARTER

Figure 48.

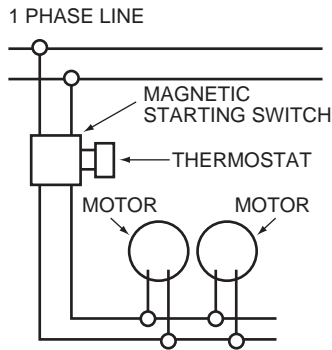

THERMOSTATIC CONTROL USING MAGNETIC STARTER OPERATING SEVERAL UNITS

Figure 49.

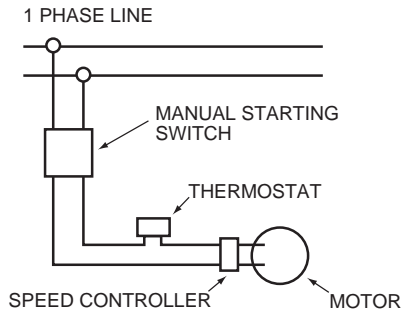

SPEED CONTROLLER WITH MANUAL STARTING SWITCH

Figure 50.

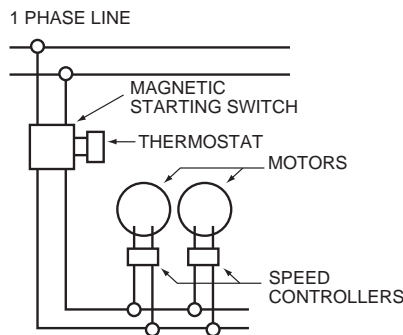

SPEED CONTROLLERS WITH MAGNETIC STARTING SWITCH FOR OPERATING SEVERAL UNITS

Figure 51.

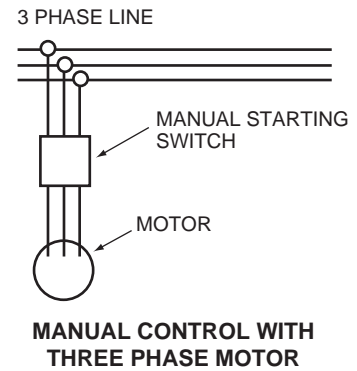

MANUAL CONTROL WITH THREE PHASE MOTOR

Figure 52.

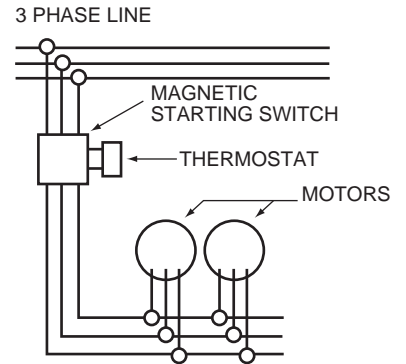

THERMOSTATIC CONTROL OF SEVERAL THREE PHASE UNITS

Figure 53.

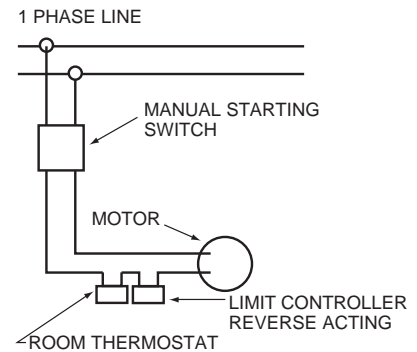

THERMOSTATIC CONTROL WITH ACTING LIMIT CONTROLLER AND MANUAL STARTER

Figure 54.

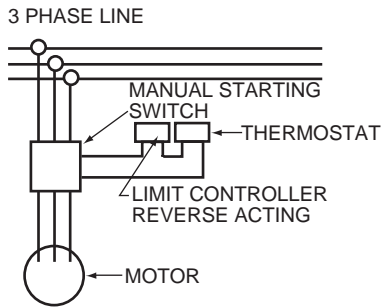

MANUAL CONTROL WITH THREE PHASE MOTOR

Figure 55.

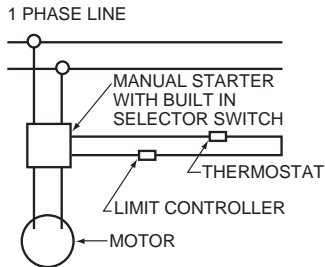

THREE POSITION SELECTOR SWITCH BUILT INTO MAGNETIC STARTER FOR MANUAL OR THERMOSTATIC CONTROL

Figure 56.

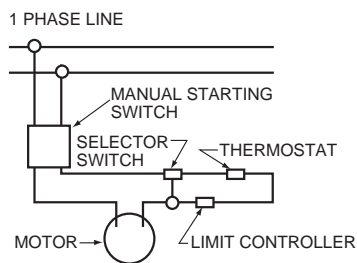

THREE POSITION SELECTOR SWITCH USED FOR EITHER MANUAL OR THERMOSTATIC CONTROL

Figure 57.



Motor Data

Motor Data: P Models

⚠ CAUTION Voltage Selections

Select appropriate AMP, MCA, and MOP for the multiple voltage motors. For example, the AMP, MCA, and MOP for Model 40 with a 230 volt Totally Enclosed motor is 1.1, 1.4, and 2.5 respectively.

Note: All motors are constant speed and operate at top speed as indicated in motor data. Models through 1/8 H.P. can be run at reduced speed with addition of optional variable speed switch. This switch is factory-calibrated for low and high speed ratings, with intermediate speeds infinitely controllable. Models 166 through 720 operate at constant speed as indicated in motor data.

Note: Stated draw is Full Load (FLA). AMP draw varies by motor manufacturer $\pm .2$ AMPS. Verify FLA on motor data plate.

For Table 16

- * Optional variable speed switch is available.
- ** These motors have automatic thermal overload protection or impedance protection.
- *** These motors are 230/460 volts only.
- † Models 336 through 720 are not available for either Totally Enclosed or Explosion Proof with Overload 115/1/60 motor types.

Table 16. Standard (Totally Enclosed) Motor Type [MT=1]

Unit Model No.	AMP	MCA	MOP	HP	RPM
115/1/60† Operating Voltage					
42	1.23**	1.6	2.8	1/40*	1550
64	2.1**	2.6	4.7	1/20*	1550
80					
102	1.2**	1.5	2.7	1/8*	1070
122					
146	2.3**	2.9	5.2	1/6	1100
166					
202	3.6**	4.5	8.1	1/4	1100
252	3.6**	4.5	8.1	1/4	1100
280	5.4**	6.8	12.2	1/2	1100
208-230/460/3/60 Operating Voltage					
42	0.98-1.1/0.55	1.2-1.4/0.7	2.2-2.5/1.2	1/6	1140
64	0.98-1.1/0.55	1.2-1.4/0.7	2.2-2.5/1.2	1/6	1140
80					
102	0.98-1.1/0.55	1.2-1.4/0.7	2.2-2.5/1.2	1/6	1140
122					
146	0.98-1.1/0.55	1.2-1.4/0.7	2.2-2.5/1.2	1/6	1140
166					
202	1.2-1.4/0.7	1.5-1.8/0.9	2.7-3.2/1.6	1/4	1140
252	1.2-1.4/0.7	1.5-1.8/0.9	2.7-3.2/1.6	1/4	1140
280	1.8-2.0/1.0	2.3-2.5/1.3	4.1-4.5/2.3	1/2	1140
336	3.1-3.2/1.6	3.9-4.0/2.0	7.0-7.2/3.6	3/4	1140
384					
500	5.3-5.0/2.5	6.6-6.3/3.1	11.9-11.3/5.6	1-1/2	1160
600					
720	9.9-9.8/4.9	12.4-12.3/6.1	22.3-22.1/11.0	3	1165
575/3/60 Operating Voltage					
42					
64					
80					
102					
122					
146	0.6	0.8	1.4	1/3	1140
166					
202					
252					
280	0.8	1.0	1.8	1/2	1140
336	1.3	1.6	2.9	3/4	1140
384					
500	2.0	2.5	4.5	1-1/2	1160
600					
720	3.8	4.7	8.4	3	1165

Table 17. Explosion Proof with Thermal Overload Motor Type [MT=2]

Unit Model No.	AMP	MCA	MOP	HP	RPM
115/1/60+ Operating Voltage					
42	3.8	4.8	8.6	1/6	1140
64	3.8	4.8	8.6	1/6	1140
80					
102	3.8	4.8	8.6	1/6	1140
122					
146	3.8	4.8	8.6	1/6	1140
166					
202	4.4	5.5	9.9	1/4	1140
252	4.4	5.5	9.9	1/4	1140
280	7.8	9.8	17.6	1/2	1140
208-230/460/3/60 Operating Voltage					
42	1.0-1.0/0.5	1.3-1.3/0.6	2.3-2.3/1.1	1/6	1140
64	1.0-1.0/0.5	1.3-1.3/0.6	2.3-2.3/1.1	1/6	1140
80					
102	1.0-1.0/0.5	1.3-1.3/0.6	2.3-2.3/1.1	1/6	1140
122					
146	1.0-1.0/0.5	1.3-1.3/0.6	2.3-2.3/1.1	1/6	1140
166					
202	1.1-1.1/0.55	1.4-1.4/0.7	2.5-2.5/1.2	1/4	1140
252	1.1-1.1/0.55	1.4-1.4/0.7	2.5-2.5/1.2	1/4	1140
280	1.9/0.95***	2.4/1.2	4.3/2.1	1/2	1140
336	3.1-3.2/1.6	3.9-4.0/2.0	7.0-7.2/3.6	3/4	1145
384					
500	5.0/2.5***	6.5/3.3	11.7/5.9	1-1/2	1150
600					
720	10.0/5.0***	12.5/6.3	22.5/11.3	3	1150

For Table 17

- * Optional variable speed switch is available.
- ** These motors have automatic thermal overload protection or impedance protection.
- *** These motors are 230/460 volts only.
- † Models 336 through 720 are not available for either Totally Enclosed or Explosion Proof with Overload 115/1/60 motor types.

Motor Data: S Models

CAUTION Voltage Selections

Select appropriate AMP, MCA, and MOP for the multiple voltage motors. For example, the AMP, MCA, and MOP for Models 360 with a 460 volt Totally Enclosed motor is 1.3, 1.6, and 2.9 respectively.

Also refer to Maintenance section for additional motor data.

Note: All motors are constant speed and operate at top speed as indicated in motor data. Models 18 through 108, including A08, A18, A25 and A36 can be run at reduced speed with addition of optional variable speed switch. This switch is factory-calibrated for low and high speed ratings, with intermediate speeds infinitely controllable. Models 120 through 360 operate at constant speed as indicated

in motor data. All 1/4 H.P. motors are P.S.C.

Note: Motors under 1/3 H.P. are totally enclosed, frame mounted, 115/1/60 with thermal overload protection and permanently lubricated sleeve bearings with optional speed controller available. 1/3 H.P. (115/1/60) motors are open frame constant speed with thermal over-load protection and ball bearings. 1/3 H.P. (230V) and 1/2 H.P. (230V) motors are open frame constant speed with thermal overload protection and ball bearings.

Note: 1/3 and 1/2 H.P. motors are available as 230V single and 3 phase in open frame and explosion-proof housings, all available as options. 1/3 and 1/2 H.P. motors operate at single speed only.

Note: Stated AMP draw is Full Load Amp (FLA). AMP draw varies by motor manufacturer ± 0.2 AMPS. Verify FLA per unit motor data plate.



Motor Data

Table 18. Totally Enclosed Motor Type

Unit Model No.	AMP	MCA	MOP	HP	RPM
115/1/60					
18, 24, A08, A18	0.8	1	1.8	16W*	1550
A36	1.4	1.8	3.2	1/20*	1000
36, A25	1.2	1.5	2.7	25W*	1550
48, 60, 72	1.4	1.8	3.2	1/20*	1000
84, 96, 108	2.2	2.8	5.0	1/12*	1000
120, 132, 144, 156, 180, 204, 240	4.5	5.6	10.1	1/3	1140
280, 300, 360	5.4	6.8	12.2	1/2	1100
230/1/60					
18, 24, A08, A18	0.4	0.5	0.9	16W	1550
A36	1.4	1.8	3.2	1/20†	1000
36, A25	0.6	0.8	1.4	25W	1550
48, 60, 72	1.4	1.8	3.2	1/20†	1000
84, 96, 108	2.2	2.8	5.0	1/12†	1000
120, 132, 144, 156, 180, 204, 240	4.5	5.6	10.1	1/3†	1140
280, 300, 360	5.4	6.8	12.2	1/2†	1100
208-230/460/3/60					
48, 60, 72, 84, 96, 108, 120, 132, 144, 156, 180, 204, 240, 280, 300, 360	2.6-2.6/1.3	3.3-3.3/1.6	5.9-5.9/2.9	1/2**	1140

*Optional variable speed switch is available.

**These motors are without thermal overload protection.

†230/1/60 unit has 115/1/60 motor supplied with field installed stepdown transformer.

Table 19. Explosion Proof with Thermal Overload Motor Type

Unit Model No.	AMP	MCA	MOP	HP	RPM	AMP	MCA	MOP	HP	RPM
115-230/1/60						230/460/3/60				
48, 60, 72, 84, 96, 108, 120, 132	3.7	4.6	8.3	1/6†	1140	-	-	-	-	-
144, 156, 180, 204	5.4	6.8	12.2	1/4†	1140	2.2/1.1	2.8/1.4	5.0/2.5	1/3	1140
240, 280, 300	7.4-3.7	9.3-4.7	16.7-8.3	1/3***	1140	2.2/1.1	2.8/1.4	5.0/2.5	1/3	1140
360	7.4-3.7	9.3-4.7	16.7-8.3	1/2***	1140	2.2/1.1	2.8/1.4	5.0/2.5	1/3	1140

†230/1/60 unit has 115/1/60 motor supplied with field installed stepdown transformer.



Steam Performance Data

Table 20. Model S Header Type Only

Unit Size	Output BTU/ HR* (kW)	Cond. lbs./hr. (kg/hr)	E.D.R. Sq. Ft. (sq. m)	Final Air Deg. °F (Deg. °C)	Motor HP (kW)	RPM	Nominal CFM (m ³ /s)	Outlet FPM (m/s)	Nom. Amps @ 115 VAC†	Nom. Fan Diam. Inches (mm)
018	18,000 (5.3)	18.0 (8.2)	75 (7.0)	102 (39)	16 Watts	1550	395 (.186)	395 (2.007)	0.80	9 (228.6)
	16,200 (4.7)	16.2 (7.3)	68 (6.3)	105 (41)		1350	330 (.156)	330 (1.676)		9 (228.6)
024	24,000 (7.0)	24.5 (11.1)	100 (9.3)	109 (43)	16 Watts	1550	450 (.212)	450 (2.286)	0.80	10 (254.0)
	21,600 (6.3)	22.0 (10.0)	90 (8.4)	112 (44)		1350	380 (.179)	380 (1.930)		10 (254.0)
036	36,000 (10.5)	37.0 (16.8)	150 (13.9)	119 (48)	25 Watts	1550	550 (.260)	550 (2.794)	1.2	10 (254.0)
	32,400 (9.5)	33.0 (14.9)	135 (12.5)	120 (49)		1350	480 (.227)	480 (2.438)		10 (254.0)
048	48,000 (14.1)	49.0 (22.2)	200 (18.6)	119 (48)	1/20 (.037)	1000	750 (.354)	550 (2.794)	1.4	12 (304.8)
	43,200 (12.7)	44.0 (19.9)	180 (16.7)	123 (51)		900	630 (.297)	460 (2.337)		12 (304.8)
060	60,000 (17.6)	61.0 (27.6)	250 (23.2)	121 (49)	1/20 (.037)	1000	900 (.425)	650 (3.302)	1.4	12 (304.8)
	54,000 (15.8)	55.0 (24.9)	225 (20.9)	131 (55)		900	700 (.330)	510 (2.591)		12 (304.8)
072	72,000 (21.1)	73.0 (33.1)	300 (27.9)	120 (49)	1/20 (.037)	1000	1100 (.519)	800 (4.064)	1.4	14 (355.6)
	64,800 (19.0)	66.0 (29.9)	270 (25.1)	123 (51)		900	950 (.448)	700 (3.556)		14 (355.6)
084	84,000 (24.6)	85.0 (38.5)	350 (32.5)	115 (46)	1/12 (.062)	1000	1400 (.661)	900 (4.572)	2.2	14 (355.6)
	75,600 (22.2)	76.0 (34.4)	315 (29.3)	123 (51)		900	1100 (.519)	750 (3.810)		14 (355.6)
096	96,000 (28.1)	97.0 (43.9)	400 (37.2)	123 (51)	1/12 (.062)	1000	1400 (.661)	930 (4.724)	2.2	16 (406.4)
	86,400 (25.3)	88.0 (39.9)	360 (33.4)	132 (56)		900	1100 (.519)	800 (4.064)		16 (406.4)
108	108,000 (31.6)	110.0 (49.8)	450 (41.8)	115 (46)	1/12 (.062)	1000	1800 (.850)	1000 (5.080)	2.2	16 (406.4)
	97,200 (28.5)	98.0 (44.4)	405 (37.6)	120 (49)		900	1500 (.708)	900 (4.572)		16 (406.4)
120	120,000 (35.2)	122.0 (55.3)	500 (46.5)	118 (48)	1/3 (.249)	1140	1900 (.897)	900 (4.572)	4.5	18 (457.2)
132	132,000 (38.7)	134.0 (60.7)	550 (51.1)	121 (49)	1/3 (.249)	1140	2000 (.944)	950 (4.826)	4.5	18 (457.2)
144	144,000 (42.2)	146.0 (66.1)	600 (55.7)	120 (49)	1/3 (.249)	1140	2200 (1.038)	1000 (5.080)	4.5	18 (457.2)
156	156,000 (45.7)	160.0 (72.5)	650 (60.4)	115 (46)	1/3 (.249)	1140	2600 (1.227)	1150 (5.842)	4.5	18 (457.2)
180	180,000 (52.7)	190.0 (86.1)	770 (71.5)	135 (57)	1/3 (.249)	1140	2200 (1.038)	800 (4.064)	4.5	18 (457.2)
204	204,000 (59.8)	208.0 (94.2)	850 (79.0)	124 (51)	1/3 (.249)	1140	2900 (1.369)	1000 (5.080)	4.5	18 (457.2)
240	240,000 (70.3)	244.0 (110.5)	1000 (92.9)	123 (51)	1/3 (.249)	1140	3500 (1.652)	900 (4.572)	4.5	20 (508.0)



Steam Performance Data

Table 20. Model S Header Type Only (continued)

Unit Size	Output BTU/ HR* (kW)	Cond. lbs./hr. (kg/hr)	E.D.R. Sq. Ft. (sq. m)	Final Air Deg. °F (Deg. °C)	Motor HP (kW)	RPM	Nominal CFM (m ³ /s)	Outlet FPM (m/s)	Nom. Amps @ 115 VAC†	Nom. Fan Diam. Inches (mm)
280	280,000 (82.0)	280.0 (126.8)	1100 (102.2)	121 (49)	1/2 (.373)	1100	4200 (1.982)	980 (4.978)	5.4	20 (508.0)
300	300,000 (87.9)	310.0 (140.4)	1250 (116.1)	117 (47)	1/2 (.373)	1100	5000 (2.360)	700 (3.556)	5.4	24 (609.6)
360	360,000 (105.5)	366.0 (165.8)	1500 (139.4)	120 (49)	1/2 (.373)	1100	5500 (2.596)	1000 (5.080)	5.4	24 (609.6)

Performance based on 2# steam pressure (13.8 kpa) at heater with air entering @ 60°F (16°C).

For Sound Ratings See Pages 28 and 29.

Use conversion table for all metric conversions.

* For the lower output, an optional Speed Controller must be ordered.

† Stated AMP is full load for the standard motors. AMP draw varies by motor manufacturer ± 0.2 AMPS. Please see your unit's motor data plate for exact (FLA) Full Load Amp rating.

Table 21. Steam Calculations and Correction Factors

		EXAMPLE:
		Unit Size: _____ 24
		Steam Pressure _____ 10 PSI
		Entering Air Temp. _____ 40°F
I. CAPACITY	Read output directly from Table 20 , 24,000 BTU/HR. (Ref., Std. 24).	
A. For 2 lbs. steam, 60° entering air		
B. For higher steam pressures and/or E.A.T.'s above or below 60°F	Multiply output from Table 20 by appropriate correction factor from Table 22	24,000 x 1.29 = 30,960 BTU/HR.
II. FINAL AIR TEMPERATURE	Read temperature directly from Table 20 , 109°F. (Ref., Std. 24)	
A. For 2 lbs. steam, 60° entering air		
B. For capacities calculated in I.B. (above)	Output from I.B./1.085 x CFM from Table 20 + E.A.T. = Final Air Temp	30,960/1.085 x 450 + 40 = 103.4°F.
III. FINAL AIR VOLUME	460 + Final Air Temp from Table 20 / 530 x Nom. CFM from Table 20 = Final Air Volume	460 + 109 / 530 x 450 = 483 CFM
A. For 2 lbs. steam, 60° entering air		
B. For final air temperatures calculated in II.B. (above)	460 + Final Air Temp from II.B. / 530 x Nom. CFM from Table 20 = Final Air Volume	460 + 103.4 / 530 x 450 = 478 CFM
IV. CONDENSATE PER HOUR	Read lbs. per hour from Table 20 , 24.5 LBS./HR. (Ref., Std. 24).	
A. For 2 lbs. steam, 60° entering air		
B. For capacities calculated in I.B. (above)	Output from I.B. / Latent Heat From Table 23 = lbs. per hour of condensate	30,960 / 953 = 32.5 LBS./HR.

Table 22. STEAM CORRECTION FACTORS BASED ON 2 PSI (13.8 kPa) STEAM AND 60 Deg. F (16 Deg. C) E.A.T.

ENTERING AIR TEMP Deg. F (Deg. C)	STEAM PRESSURE (SATURATED) - LBS. PER SQ. IN. (kPa)													
	0 (0)	2 (13.8)	5 (34.5)	10 (68.9)	15 (103.4)	20 (137.9)	30 (206.8)	40 (275.8)	50 (344.7)	75 (517.1)	100 (689.4)	125 (861.8)	150 (1,034.1)	
30 (-1)	1.19	1.24	1.29	1.38	1.44	1.50	1.60	1.68	1.70	1.90	2.02	2.11	2.20	
40 (4)	1.11	1.16	1.21	1.29	1.34	1.42	1.51	1.60	1.66	1.81	1.93	2.02	2.11	
50 (10)	1.03	1.08	1.13	1.21	1.28	1.33	1.43	1.51	1.58	1.72	1.84	1.93	2.02	
60 (16)	0.96	1.00	1.05	1.13	1.19	1.25	1.35	1.43	1.50	1.64	1.75	1.84	1.93	
70 (21)	0.88	0.93	0.97	1.06	1.12	1.17	1.27	1.35	1.42	1.55	1.66	1.76	1.84	
80 (27)	0.81	0.85	0.90	0.98	1.04	1.10	1.19	1.27	1.34	1.47	1.58	1.68	1.76	
90 (32)	0.74	0.78	0.83	0.91	0.97	1.02	1.12	1.19	1.26	1.39	1.50	1.59	1.67	
100 (38)	0.67	0.71	0.76	0.84	0.89	0.95	1.04	1.12	1.19	1.32	1.42	1.51	1.59	



Steam Performance Data

Table 23. PROPERTIES OF SATURATED STEAM

STEAM PRESSURE IN PSIG (kPa)													
Steam Pressure psi (kPa)	0 (0)	2 (13.8)	5 (34.5)	10 (68.9)	15 (103.4)	20 (137.9)	30 (206.8)	40 (275.8)	50 (344.7)	75 (517.1)	100 (689.4)	125 (891.8)	150 (1,034.1)
Steam Temperature Deg. F (Deg. C)	212 (100)	218.5 (103.6)	227.1 (108.4)	239.4 (115.2)	249.8 (121.0)	258.8 (126.0)	274.0 (134.4)	286.7 (141.5)	297.7 (147.6)	319.9 (159.9)	337.9 (169.9)	352.9 (178.3)	365.9 (185.5)
Latent Heat of Steam Btu/lbm (KJ/Kg)	970 (2256)	966 (2247)	961 (2235)	953 (2217)	946 (2200)	940 (2186)	929 (2161)	920 (2140)	912 (2121)	891 (2072)	881 (2049)	868 (2019)	857 (1993)

Table 24. Model P Standard Units

Unit Capacity (MBH)	Output BTU/HR (kW)	Condensate lbs./hr (kg/hr)	E.D.R. Sq. ft. (Sq. m)	Final Air Temp °F (°C)	Motor H.P. (kW)	Motor RPM	Nominal CFM (m ³ /s)	Outlet Velocity FPM (m/s)	Sound Rating
042	41,300 (12.1)	43 (19.5)	172 (16.0)	124 (51)	1/40 (.019)	1550	595 (.278)	877 (4.455)	I
	33,600 (9.8)	55 (24.9)	140 (13.0)	131 (55)			436 (.203)	658 (3.343)	
064	65,500 (19.2)	68 (30.8)	273 (25.4)	121 (49)	1/20 (.037)	1150	989 (.462)	1005 (5.105)	II
	52,800 (15.5)	55 (24.9)	220 (20.5)	129 (54)			706 (.329)	727 (3.693)	
080	80,600 (23.6)	83 (37.6)	336 (31.3)	122 (50)	1/20 (.037)	1150	1200 (.560)	1220 (6.198)	II
	65,100 (19.1)	67 (30.4)	271 (25.2)	130 (54)			858 (.400)	894 (4.542)	
102	101,800 (29.8)	106 (48.0)	424 (39.4)	123 (51)	1/8 (.093)	1070	1490 (.695)	980 (4.978)	II
	87,900 (25.8)	91 (41.2)	366 (34.0)	129 (54)			1180 (.551)	783 (3.978)	
122	124,400 (36.4)	129 (58.4)	518 (48.2)	124 (51)	1/6 (.124)	1100	1790 (.835)	1170 (5.944)	III
146	152,000 (44.5)	157 (71.1)	633 (58.9)	123 (51)	1/6 (.124)	1100	2220 (1.036)	1045 (5.309)	III
166	173,000 (50.7)	179 (81.1)	720 (67.0)	121 (49)	1/6 (.124)	1100	2620 (1.223)	1230 (6.248)	IV
202	210,200 (61.6)	208 (94.2)	838 (78.0)	118 (48)	1/4 (.186)	1100	3200 (1.493)	1495 (7.595)	III
252	249,800 (73.2)	260 (117.8)	1040 (96.7)	115 (46)	1/4 (.186)	1100	4180 (1.951)	1205 (6.121)	IV
280	283,800 (83.2)	294 (133.2)	1180 (109.8)	119 (48)	1/2 (.373)	1100	4430 (2.067)	1275 (6.477)	IV
336	333,400 (97.7)	345 (156.3)	1390 (129.3)	119 (48)	3/4 (.559)	1140	5210 (2.431)	1500 (7.620)	IV
384	386,000 (113.1)	400 (181.2)	1610 (149.8)	118 (48)	3/4 (.559)	1140	6140 (2.865)	1770 (8.992)	IV
500	496,000 (145.3)	514 (232.8)	2070 (192.6)	117 (47)	1-1/2 (1.119)	1175	8020 (3.743)	1640 (8.331)	IV
600	585,000 (171.4)	605 (274.1)	2440 (227.0)	117 (47)	1-1/2 (1.119)	1175	9450 (4.410)	1930 (9.804)	IV
720	705,000 (206.6)	729 (330.2)	2940 (273.5)	119 (48)	3 (2.237)	1165	11,000 (5.133)	2250 (11.430)	IV

E.D.R. = Equivalent Direct Radiation

NOTES:

Constant speed units are rated at capacities shown in regular type; capacities shown in italic faced type apply only to units with multi-speed motors.

** Performance data based on 2 lbs. steam pressure at heater with air entering @60°F.

To determine BTU per hour capacities at various steam pressures and entering air temperatures, use conversion factors from Table 7. Final temperatures at new conditions can be calculated by applying basic formula.



Steam Performance Data

Table 25. "Low Output" Standard Vertical Units with All Air Ports Open

Unit Capacity (MBH)	Output BTU/HR (kW)	Condensate lbs./hr (kg/hr)	E.D.R. Sq. ft. (Sq. m)	Final Air Temp. °F (°C)	Motor H.P. (kW)	Motor RPM	Nominal CFM (m ³ /s)	Outlet Velocity FPM (m/s)	Sound Rating
042L	34,800 (10.2)	36 (16.3)	145 (13.5)	108 (42)	1/40 (.019)	1550	668 (.312)	950 (4.826)	I
	26,000 (7.6)	27 (12.2)	108 (10.0)	111 (44)		1150	470 (.219)	672 (3.414)	
064L	57,200 (16.8)	59 (26.7)	238 (22.1)	104 (40)	1/20 (.037)	1550	1200 (.560)	1190 (6.045)	I
	45,800 (13.4)	48 (21.7)	191 (17.8)	109 (43)		1150	862 (.402)	858 (4.359)	
	68,000 (19.9)	71 (32.2)	283 (26.3)	106 (41)		1550	1360 (.635)	1350 (6.858)	
080L	55,000 (16.1)	57 (25.8)	229 (21.3)	111 (44)	1/20 (.037)	1150	995 (.464)	992 (5.039)	II
	85,400 (25.0)	89 (40.3)	356 (33.1)	108 (42)	1/8 (.093)	1070	1640 (.765)	1050 (5.334)	II
71,200 (20.9)	74 (33.5)	296 (27.5)	111 (44)	850		1290 (.602)	827 (4.201)		
122L	111,000 (32.5)	115 (52.1)	462 (43.0)	107 (42)	1/6 (.124)	1100	2180 (1.017)	1390 (7.061)	III
146L	125,000 (36.6)	130 (58.9)	524 (48.7)	109 (43)	1/6 (.124)	1100	2360 (1.101)	1080 (5.486)	III
166L	149,000 (43.7)	154 (69.8)	620 (57.7)	107 (42)	1/6 (.124)	1100	2920 (1.363)	1340 (6.807)	IV
202L	176,800 (51.8)	183 (82.9)	736 (68.5)	108 (42)	1/4 (.186)	1100	3390 (1.582)	1560 (7.925)	III
252L	214,900 (63.0)	224 (101.5)	895 (83.3)	104 (40)	1/4 (.186)	1100	4500 (2.100)	1270 (6.452)	IV
280L	251,800 (73.8)	260 (117.8)	1050 (97.7)	106 (41)	1/2 (.373)	1100	5040 (2.352)	1420 (7.214)	IV
336L	291,000 (85.3)	302 (136.8)	1210 (112.6)	107 (42)	3/4 (.559)	1140	5700 (2.660)	1610 (8.179)	IV
384L	344,000 (100.8)	356 (161.3)	1430 (133.0)	108 (42)	3/4 (.559)	1140	6600 (3.080)	1870 (9.500)	IV
500L	428,000 (125.4)	446 (202.0)	1785 (166.0)	102 (39)	1-1/2 (1.119)	1175	9380 (4.377)	1860 (9.449)	IV
600L	515,000 (150.9)	533 (241.4)	2140 (199.1)	106 (41)	1-1/2 (1.119)	1175	10,300 (4.807)	2060 (10.465)	IV
720L	620,000 (181.7)	642 (290.8)	2580 (240.0)	108 (42)	3 (2.237)	1165	11,900 (5.553)	2380 (12.090)	IV

E.D.R. = Equivalent Direct Radiation

NOTES:

Constant speed units are rated at capacities shown in regular type; capacities shown in italic faced type apply only to units with multi-speed motors.

** Performance data based on 2 lbs. steam pressure at heater with air entering @60°F.

To determine BTU per hour capacities at various steam pressures and entering air temperatures, use conversion factors from Table 7. Final temperatures at new conditions can be calculated by applying basic formula.



Steam Performance Data

Table 26. STEAM CALCULATIONS AND CORRECTION FACTORS P STYLE

		EXAMPLE:
		UNIT SIZE _____ 042 Steam Pressure _____ 10 PSI Entering Air Temp. _____ 40°F
I. CAPACITY	Read output directly from Table 24 : 41,300 BTU/HR.	
A. For 2 lbs. steam, 60° entering air		
B. For higher steam pressures and/or E.A.T.'s above or below 60°F	Multiply output from Table 24 by appropriate correction factor from Table 27 .	41,300 x 1.27 = 52,451 BTU/HR.
II. FINAL AIR TEMPERATURE	Read temperature directly from Table 24 : 124°F.	
A. For 2 lbs. steam, 60° entering air		
B. For capacities calculated in I.B. (above)	Output from I.B./1.085 x CFM from Table 24 + E.A.T. = Final Air Temp	52,451/1.085 x 595 + 40 = 121.0°F
III. FINAL AIR VOLUME	460 + Final Air Temp from Table 24 530 x Nom. CFM from Table 24 = Final Air Volume	460 + 124/530 x 595 = 655 CFM
A. For 2 lbs. steam, 60° entering air		
B. For final air temperatures calculated in II. B. (above)	460 + Final Air Temp from II.B./530 x Nom. CFM from Table 24 = Final Air Volume	460 + 121.0/530 x 595 = 652 CFM
IV. CONDENSATE PER HOUR	Read lbs. per hour from Table 24 : 43 LBS./HR.	
A. For 2 lbs. steam, 60° entering air		
B. For capacities calculated in I.B. (above)	Output from I.B./Latent Heat From Table 28 = lbs. per hour of condensate	52,451/953 = 55.0 LBS./HR.

Table 27. STEAM CORRECTION FACTORS BASED ON 2 LBS. STEAM 60° E.A.T.

ENTERING AIR TEMP °F (°C)	STEAM PRESSURE - LBS. PER SQ. IN. (SATURATED)									
	0 (.0)	2 (13.8)	5 (34.5)	10 (68.9)	15 (103.4)	20 (137.9)	30 (206.8)	40 (275.8)	50 (344.7)	75 (517.1)
30° (-1°)	1.18	1.22	1.27	1.34	1.40	1.45	1.53	1.61	1.67	1.79
40° (4°)	1.11	1.15	1.20	1.27	1.32	1.37	1.46	1.53	1.59	1.71
50° (10°)	1.03	1.07	1.12	1.19	1.25	1.30	1.39	1.46	1.52	1.64
60° (16°)	0.96	1.00	1.05	1.12	1.18	1.23	1.32	1.39	1.45	1.57
70° (21°)	0.90	0.93	0.98	1.05	1.11	1.16	1.25	1.32	1.38	1.49
80° (27°)	0.83	0.86	0.91	0.98	1.04	1.09	1.18	1.25	1.31	1.42
90° (32°)	0.76	0.80	0.85	0.91	0.97	1.02	1.11	1.18	1.24	1.36
100° (38°)	0.69	0.73	0.78	0.85	0.90	0.96	1.04	1.11	1.17	1.29

Table 28. PROPERTIES OF SATURATED STEAM

	STEAM PRESSURE IN LBS. PER SQUARE INCH GAUGE									
	0 (.0)	2 (13.8)	5 (34.5)	10 (68.9)	15 (103.4)	20 (137.9)	30 (206.8)	40 (275.8)	50 (344.7)	75 (517.1)
Steam Temperature-°F (°C)	212.0 (100.0)	218.5 (103.6)	227.1 (108.4)	239.4 (115.2)	249.8 (121.0)	258.8 (126.0)	274.0 (134.4)	286.7 (141.5)	297.7 (147.6)	319.9 (159.9)
Latent Heat of Steam-Btu/lbm (KJ/Kg)	970 (2256)	966 (2247)	961 (2235)	953 (2217)	946 (2200)	940 (2186)	929 (2161)	920 (2140)	912 (2121)	891 (2072)

Note: Ratings apply only to free inlet and discharge without diffusers.

Note: All motors are constant speed and operate at top speed as indicated in motor data. Models 42 through 102 can be run at reduced speed with addition of optional variable speed switch. This switch is factory-calibrated for low and high speed ratings, with intermediate speeds in?nitely controllable. Models 166 through 720 operate at constant speed as indicated in motor data.

Note: For specific motor data refer to motor specifications in [Table 16](#) and [Table 17](#).

Note: To correct for entering air temperatures, use 1° temperature rise for each foot in mounting height. As an example, 60° air is r equired at work area (5 ft. above ?oor) units are to be mounted at (20 ft.) above floor. Mounting height (20 ft.) minus work height (5 ft.) equals differential (15 ft.) or, 15° rise in air temperature at unit air inlet. Correct for actual inlet air temperature of 75° (60° + 15° = 75° E.A.T.) on [Table 6](#).



Hot Water Performance Data

Table 29. Model S Serpentine and Header Type

Unit Size	Output BTU/HR* (kW)	Flow Rate GPM (L/s)	Final Air Deg. °F (Deg. °C)	Prssr. Drop FT./H2O (m/water)	Motor HP (kW)	RPM	Nominal CFM (m ³ /s)	Outlet FPM (m/s)	Nom. Amps @ 115VAC†	Sound Rating
A08	8,030 (2.4)	0.8 (.050)	91 (33)	0.80 (.244)	16 Watts	1550	245 (.116)	250 (1.270)	0.80	II
	6,800 (2.0)		90 (32)			1350	210 (.099)	215 (1.092)		I
A18	18,400 (5.4)	1.9 (.120)	94 (34)	2.20 (.671)	16 Watts	1550	500 (.236)	500 (2.540)	0.80	II
	15,650 (4.6)		96 (36)			1350	420 (.198)	420 (2.134)		I
A25	24,800 (7.3)	2.5 (.158)	102 (39)	2.20 (.671)	25 Watts	1550	580 (.274)	590 (2.997)	1.2	II
	21,230 (6.2)		106 (41)			1350	460 (.217)	450 (2.286)		I
A36	35,900 (10.5)	3.6 (.227)	99 (37)	3.00 (.914)	1/20 (.037)	1000	850 (.401)	550 (2.794)	1.4	II
	32,300 (9.5)		100 (38)			900	750 (.354)	480 (2.438)		I
018	13,050 (3.8)	1.3 (.082)	95 (35)	0.005 (.002)	16 Watts	1550	395 (.186)	395 (2.007)	0.80	II
	11,725 (3.4)		99 (37)			1350	350 (.165)	350 (1.778)		I
024	17,400 (5.1)	1.8 (.114)	96 (36)	0.014 (.004)	16 Watts	1550	450 (.212)	450 (2.286)	0.80	II
	15,600 (4.6)		98 (37)			1350	380 (.179)	380 (1.930)		I
036	26,100 (7.6)	2.7 (.170)	103 (39)	0.09 (.027)	25 Watts	1550	550 (.260)	550 (2.794)	1.2	II
	23,500 (6.9)		103 (39)			1350	480 (.227)	480 (2.438)		I
048	34,800 (10.2)	3.5 (.221)	103 (39)	0.12 (.037)	1/20 (.037)	1000	750 (.354)	550 (2.794)	1.4	II
	31,300 (9.2)		111 (44)			900	630 (.297)	460 (2.337)		I
060	43,600 (12.8)	4.4 (.278)	105 (41)	0.17 (.052)	1/20 (.037)	1000	900 (.425)	650 (3.302)	1.4	II
	39,200 (11.5)		112 (44)			900	700 (.330)	510 (2.591)		I
072	52,300 (15.3)	5.3 (.334)	104 (40)	0.23 (.070)	1/20 (.037)	1000	1100 (.519)	800 (4.064)	1.4	II
	47,000 (13.8)		106 (41)			900	950 (.448)	700 (3.556)		I
084	61,000 (17.9)	6.1 (.385)	100 (38)	0.24 (.073)	1/12 (.062)	1000	1400 (.661)	900 (4.572)	2.2	III
	54,900 (16.1)		106 (41)			900	1100 (.519)	750 (3.810)		II
096	69,700 (20.4)	7.0 (.442)	106 (41)	0.29 (.088)	1/12 (.062)	1000	1400 (.661)	930 (4.724)	2.2	III
	62,700 (18.4)		113 45			900	1100 (.519)	800 (4.064)		II
108	78,400 (23.0)	7.9 (.498)	100 (38)	0.36 (.110)	1/12 (.062)	1000	1800 (.850)	1000 (5.080)	2.2	III
	70,500 (20.7)		103 (39)			900	1500 (.708)	900 (4.572)		II



Hot Water Performance Data

Table 29. Model S Serpentine and Header Type (continued)

120	87,100 (25.5)	8.8 (.555)	102 (39)	0.39 (.119)	1/3 (.249)	1140	1900 (.897)	900 (4.572)	4.5	III
132	95,800 (28.1)	9.6 (.606)	104 (40)	0.41 (.125)	1/3 (.249)	1140	2000 (.944)	950 (4.826)	4.5	IV
144	104,000 (30.5)	10.4 (.656)	104 (40)	0.43 (.131)	1/3 (.249)	1140	2200 (1.038)	1000 (5.080)	4.5	IV
156	113,000 (33.1)	11.3 (.713)	100 (38)	0.53 (.162)	1/3 (.249)	1140	2600 (1.227)	1150 (5.842)	4.5	IV
180	118,000 (34.6)	11.8 (.744)	110 (43)	0.6 (.183)	1/3 (.249)	1140	2200 (1.038)	800 (4.064)	4.5	III
204	148,000 (43.4)	14.9 (.940)	107 (42)	0.79 (.241)	1/3 (.249)	1140	2900 (1.369)	1000 (5.080)	4.5	IV
240	174,000 (51.0)	17.4 (1.098)	106 (41)	1.06 (.323)	1/3 (.249)	1140	3500 (1.652)	900 (4.572)	4.5	IV
280	209,100 (61.3)	21.0 (1.325)	106 (41)	1.33 (.405)	1/2 (.373)	1100	4200 (1.982)	980 (4.978)	5.4	IV
300	230,000 (67.4)	23.0 (1.451)	102 (39)	2.1 (.640)	1/2 (.373)	1100	5000 (2.360)	700 (3.556)	5.4	IV
360	261,300 (76.6)	26.2 (1.653)	103 (39)	2.1 (.640)	1/2 (.373)	1100	5500 (2.596)	1000 (5.080)	5.4	IV

Performance based on 200°F (93°C) EWT, 60°F (16°C) E.A.T., 20°F (11°C)TD.
For Fan Diameter see Pages 41 and 42.

* For the lower output, an optional Speed Controller must be ordered.

†Stated AMP is full load for standard motors. AMP draw varies by motor manufacturer ± 0.2 AMPS. Please see your unit's motor data plate for exact (FLA) Full Load Amp rating.

Table 30. Hot Water Calculations and Correction Factors S Type

		EXAMPLE: UNIT SIZE: _____ 024 Entering Water Temp. _____ 160°F Entering Air Temp. _____ 40°F Water Temperature Drop _____ 10°F
I. CAPACITY @ 20° TD: A. For 200° EWT, 60° EAT	Read output directly from Table 29 , 17,400 BTU/HR (Ref., Std. 024)	
B. For EWT and/or EAT above or below Standard	Multiply output from Table 29 by factor from Table 31	17,400 x .878 = 15,277 BTU/HR.
II. CAPACITY AT OTHER TD's A. For TD's from 5 to 60°F	Multiply output obtained in IA. Or IB. (above) by appropriate factor from Table 32	IA-17,400 x 1.15 = 20,010 BTU/HR. -OR- IB-15,277 x 1.15 = 17,569 BTU/HR.
III. GPM AT OTHER TD's A. For TD's from 5 to 60°F	Multiply GPM of unit for 20° TD, from Table 29 by appropriate factor from Table 32	1.8 x 2.30 = 4.14 GPM (Applies only to units with Std. 200° EWT, 60° EAT.) For all others calculate using formula-GPM = BTU/500 x TD
IV. CAPACITY AT OTHER RATES OF WATER FLOW	Multiply output from Table 29 by factor from Table 34 .	
V. PRESSURE LOSS AT OTHER TD's A. For TD's from 5 to 60°F	Multiply P.D. of unit for 20°TD, from Table 29 by appropriate factor from the Table 32	.014 x 5.00 = .07 Ft. H ₂ O



Hot Water Performance Data

Table 31. HOT WATER CONVERSION FACTORS BASED ON 200° (93°C) ENTERING WATER, 60° (16°C) ENTERING AIR AND 20° (11°C) TEMPERATURE DROP

ENTERING AIR TEMPERATURE °F (°C)	ENTERING WATER TEMPERATURE - °F (°C)										
	100° (38)	120° (49)	140° (60)	160° (71)	180° (82)	200° (93)	220° (104)	240° (116)	260° (127)	280° (138)	300° (149)
30 (-1)	0.518	0.666	0.814	0.963	1.120	1.268	1.408	1.555	1.702	1.850	1.997
40 (4)	0.439	0.585	0.731	0.878	1.025	1.172	1.317	1.464	1.609	1.755	1.908
50 (10)	0.361	0.506	0.651	0.796	0.941	1.085	1.231	1.375	1.518	1.663	1.824
60 (16)	0.286	0.429	0.571	0.715	0.857	1.000	1.143	1.286	1.429	1.571	1.717
70 (21)	0.212	0.353	0.494	0.636	0.777	0.918	1.060	1.201	1.342	1.483	1.630
80 (27)	0.140	0.279	0.419	0.558	0.698	0.837	0.977	1.117	1.257	1.397	1.545
90 (32)	0.069	0.207	0.345	0.483	0.621	0.759	0.897	1.035	1.173	1.311	1.462
100 (38)	0.000	0.137	0.273	0.409	0.546	0.682	0.818	0.955	1.094	1.230	1.371

Table 32. HOT WATER OUTPUT, FLOW RATE AND PRESSURE LOSS FACTORS BASED ON STANDARD CONDITIONS OF 200°F (93°C) ENTERING WATER, 60°F (16°C) ENTERING AIR & 20°F (11°C) WATER DROP

USE FACTORS FROM THIS TABLE TO OBTAIN APPROXIMATE RESULTS	TEMPERATURE DROP °F (°C)									
	5 (3)	10 (6)	15 (8)	20 (11)	25 (14)	30 (17)	40 (22)	50 (28)	60 (33)	
To obtain output for other Water Temperature Drops, multiply basic output rating by applicable Factor.	1.25	1.15	1.08	1.00	.94	.90	.83	.76	.72	
To obtain flow for other Water Temperature Drops, multiply basic rate rating by applicable Factor.*	5.00	2.30	1.44	1.00	.74	.59	.40	.30	.24	
To obtain Pressure Loss Feet (Meters) of Water for other temperature Drops, multiply Basic loss at 20°F (11°C) drop by Factor.	10.00	5.00	2.00	1.00	.60	.40	.20	.13	.07	

Table 33. MINIMUM WATER FLOW

MODEL No.	A08	A18	A25	A36	18	24	36	48	60	72	84	96
MINIMUM GPM (L/s)	0.125 (.008)	0.125 (.008)	0.125 (.008)	0.125 (.008)	0.750 (.047)	1.240 (.078)	1.240 (.078)	1.490 (.094)	1.490 (.094)	1.620 (.102)	1.860 (.117)	3.350 (.211)
MODEL No.	108	120	132	144	156	180	204	240	280	300	360	
MINIMUM GPM (L/s)	3.35 (.211)	3.60 (.227)	4.09 (.258)	4.09 (.258)	4.09 (.258)	4.34 (.274)	4.34 (.274)	4.59 (.290)	4.59 (.290)	6.08 (.384)	6.08 (.384)	

Table 34. HEATING CAPACITY FACTORS FOR VARIOUS RATES OF WATER FLOW

% of Rated Water Flow	25%	50%	75%	100%	125%	150%	175%
Heating Capacity Factor	.80	.89	.96	1.00	1.04	1.07	1.10



Hot Water Performance Data

Table 35. P Type Standard Output Units**

Model No.	Water Temp. Drop °F (°C)	Output MBH (kW)	Flow Rate G.P.M. (L/s)	Press. Drop ft/water (m/water)	Final Air Temp. °F (°C)	Motor H.P. (kW)	R.P.M.	Nominal CFM (m ³ /s)	Outlet Velocity FPM (m/s)	Sound Rating
42	10° (5.6°)	28.8 (8.4)	5.93 (.374)	.37 (.113)	104.6° (40.3°)	1/40 (.019)	1550	595 (.278)	877 (4.455)	I
	20° (11.1°)	22.7 (6.7)	2.34 (.148)	.06 (.018)	95.2° (35.1°)					
	30° (16.7°)	16.7 (4.9)	1.15 (.073)	.02 (.006)	85.9° (29.9°)					
42*	10° (5.6°)	22.9 (6.7)	4.71 (.297)	.24 (.073)	108.3° (42.4°)	1/40 (.019)	1150	436 (.203)	658 (3.343)	I
	20° (11.1°)	18.1 (5.3)	1.87 (.118)	.04 (.012)	98.3° (36.8°)					
	30° (16.7°)	13.4 (3.9)	.92 (.058)	.01 (.003)	88.4° (31.3°)					
64	10° (5.6°)	48.1 (14.1)	9.92 (.626)	1.05 (.320)	104.8° (40.4°)	1/20 (.037)	1550	989 (.462)	1005 (5.105)	II
	20° (11.1°)	39.6 (11.6)	4.08 (.257)	.19 (.058)	96.9° (36.1°)					
	30° (16.7°)	31.1 (9.1)	2.14 (.135)	.06 (.018)	89.0° (31.7°)					
64*	10° (5.6°)	38.1 (11.2)	7.85 (.495)	.67 (.204)	109.7° (43.2°)	1/20 (.037)	1150	706 (.329)	727 (3.693)	II
	20° (11.1°)	31.5 (9.2)	3.24 (.204)	.13 (.040)	101.1° (38.4°)					
	30° (16.7°)	24.8 (7.3)	1.71 (.108)	.04 (.012)	92.4° (33.6°)					
80	10° (5.6°)	58.7 (17.2)	12.11 (.764)	.98 (.299)	105.1° (40.6°)	1/20 (.037)	1550	1200 (.560)	1220 (6.198)	II
	20° (11.1°)	48.4 (14.2)	4.99 (.315)	.18 (.055)	97.2° (36.2°)					
	30° (16.7°)	38.1 (11.2)	2.62 (.165)	.05 (.015)	89.3° (31.8°)					
80*	10° (5.6°)	46.5 (13.6)	9.59 (.605)	.63 (.192)	110.0° (43.3°)	1/20 (.037)	1150	858 (.400)	894 (4.542)	II
	20° (11.1°)	38.5 (11.3)	3.97 (.250)	.12 (.037)	101.2° (38.4°)					
	30° (16.7°)	30.5 (8.9)	2.09 (.132)	.03 (.009)	92.7° (33.7°)					
102	10° (5.6°)	77.2 (22.6)	15.91 (1.004)	2.06 (.628)	106.6° (41.4°)	1/8 (.093)	1070	1528 (.713)	980 (4.978)	II
	20° (11.1°)	68.3 (20.0)	7.03 (.443)	.44 (.134)	101.2° (38.4°)					
	30° (16.7°)	59.3 (17.4)	4.08 (.257)	.16 (.049)	95.8° (35.4°)					
102*	10° (5.6°)	63.7 (18.7)	13.13 (.828)	1.43 (.436)	108.6° (42.6°)	1/8 (.093)	850	1208 (.564)	783 (3.978)	II
	20° (11.1°)	56.5 (16.6)	5.82 (.367)	.31 (.095)	103.1° (39.5°)					
	30° (16.7°)	49.2 (14.4)	3.38 (.213)	.11 (.034)	97.6° (36.4°)					
122	10° (5.6°)	94.9 (27.8)	19.55 (1.233)	3.04 (.927)	108.9° (42.7°)	1/6 (.124)	1100	1790 (.835)	1170 (5.944)	III
	20° (11.1°)	83.7 (24.5)	8.63 (.544)	.65 (.198)	103.1° (39.5°)					
	30° (16.7°)	72.5 (21.2)	4.98 (.314)	.23 (.070)	97.3° (36.3°)					



Hot Water Performance Data

Table 35. P Type Standard Output Units** (continued)

Model No.	Water Temp. Drop °F (°C)	Output MBH (kW)	Flow Rate G.P.M. (L/s)	Press. Drop ft./water (m./water)	Final Air Temp. °F (°C)	Motor H.P. (kW)	R.P.M.	Nominal CFM (m ³ /s)	Outlet Velocity FPM (m/s)	Sound Rating
146	10° (5.6°)	117.6 (34.5)	24.24 (1.529)	4.32 (1.318)	108.8° (42.7°)	1/6 (.124)	1100	2220 (1.036)	1045 (5.309)	III
	20° (11.1°)	105.2 (30.8)	10.84 (.684)	.96 (.293)	103.7° (39.8°)					
	30° (16.7°)	92.8 (27.2)	6.38 (.402)	.36 (.110)	98.5° (36.9°)					
166	10° (5.6°)	132.4 (38.8)	27.29 (1.722)	3.67 (1.119)	106.6° (41.4°)	1/6 (.124)	1100	2620 (1.223)	1230 (6.248)	IV
	20° (11.1°)	118.6 (34.7)	12.22 (.771)	.81 (.247)	101.7° (38.7°)					
	30° (16.7°)	104.8 (30.7)	7.20 (.454)	.30 (.092)	96.9° (36.1°)					
202	10° (5.6°)	156.2 (45.8)	32.20 (2.031)	5.02 (1.531)	105.0° (40.6°)	1/4 (.186)	1100	3200 (1.493)	1495 (7.595)	III
	20° (11.1°)	139.7 (40.9)	14.40 (.908)	1.11 (.339)	100.2° (37.9°)					
	30° (16.7°)	123.2 (36.1)	8.47 (.534)	.41 (.125)	95.5° (35.3°)					
252	15° (8.3°)	188.9 (55.3)	25.95 (1.637)	3.92 (1.196)	101.8° (38.8°)	1/4 (.186)	1100	4162 (1.942)	1205 (6.121)	IV
	20° (11.1°)	180.1 (52.8)	18.56 (1.171)	2.10 (.641)	99.9° (37.7°)					
	30° (16.7°)	162.7 (47.7)	11.18 (.705)	.82 (.250)	96.0° (35.6°)					
280	15° (8.3°)	215.4 (63.1)	29.60 (1.867)	5.02 (1.531)	104.8° (40.4°)	1/2 (.373)	1100	4430 (2.067)	1275 (6.477)	IV
	20° (11.1°)	205.4 (60.2)	21.17 (1.335)	2.68 (.817)	102.7° (39.3°)					
	30° (16.7°)	185.3 (54.3)	12.73 (.803)	1.04 (.317)	98.5° (36.9°)					
336	15° (8.3°)	254.9 (74.7)	35.03 (2.210)	6.88 (2.098)	105.1° (40.6°)	3/4 (.559)	1140	5210 (2.431)	1500 (7.620)	IV
	20° (11.1°)	242.9 (71.2)	25.03 (1.579)	3.67 (1.119)	103.0° (39.4°)					
	30° (16.7°)	218.9 (64.1)	15.04 (.949)	1.42 (.433)	98.7° (37.1°)					
384	15° (8.3°)	294.7 (86.3)	40.49 (2.554)	6.60 (2.013)	104.2° (40.1°)	3/4 (.559)	1140	6140 (2.865)	1770 (8.992)	IV
	20° (11.1°)	280.8 (82.3)	28.94 (1.826)	3.52 (1.074)	102.2° (39.0°)					
	30° (16.7°)	253.1 (74.2)	17.39 (1.097)	1.36 (.415)	98.0° (36.7°)					
500	20° (11.1°)	368.1 (107.9)	37.93 (2.393)	5.81 (1.772)	102.3° (39.1°)	1-1/2 (1.119)	1160	8020 (3.743)	1640 (8.331)	IV
	30° (16.7°)	333.6 (97.7)	22.92 (1.446)	2.29 (.698)	98.3° (36.8°)					
600	15° (8.3°)	451.2 (132.2)	62.00 (3.911)	8.78 (2.678)	104.0° (40.0°)	1-1/2 (1.119)	1160	9450 (4.410)	1930 (9.804)	IV
	20° (11.1°)	431.1 (126.3)	44.43 (2.803)	4.72 (1.440)	102.0° (38.9°)					
	30° (16.7°)	391.0 (114.6)	26.86 (1.694)	1.86 (.567)	98.1° (36.7°)					



Hot Water Performance Data

Table 35. P Type Standard Output Units (continued)**

Model No.	Water Temp. Drop °F (°C)	Output MBH (kW)	Flow Rate G.P.M. (L/s)	Press. Drop ft/water (m/water)	Final Air Temp. °F (°C)	Motor H.P. (kW)	R.P.M.	Nominal CFM (m ³ /s)	Outlet Velocity FPM (m/s)	Sound Rating
720	20° (11.1°)	519.4 (152.2)	53.52 (3.376)	5.29 (1.613)	103.5° (39.7°)	3 (2.237)	1165	11,000 (5.133)	2250 (11.430)	IV
	30° (16.7°)	470.9 (138.0)	32.35 (2.041)	2.08 (.634)	99.5° (37.5°)					

**Performance based on 200° EWT, 20° T.D., 60° E.A.T. Performance at 10° & 30° T.D. is also shown. For capacities at other conditions, use the correction multipliers in the tables on page 17.

*Speed controller option is required for reduced ratings.

Table 36. Low Output Units Standard Vertical Unit with All Air Ports Open**

Model No.	Water Temp. Drop °F (°C)	Output MBH (kW)	Flow Rate G.P.M. (L/s)	Press. Drop m/water	Final Air Temp. °F (°C)	Motor H.P. (kW)	R.P.M.	Nominal CFM (m ³ /s)	Outlet Velocity FPM (m/s)	Sound Rating
42L	10° (5.6°)	23.9 (7.0)	4.92 (.310)	.26 (.079)	92.9° (33.8°)	1/40 (.019)	1550	668 (.312)	950 (4.826)	I
	20° (11.1°)	18.9 (5.5)	1.95 (.123)	.04 (.012)	86.1° (30.1°)					
	30° (16.7°)	14.0 (4.1)	.96 (.061)	.01 (.003)	79.3° (26.3°)					
42L*	10° (5.6°)	16.7 (4.9)	3.45 (.218)	.13 (.040)	92.8° (33.8°)	1/40 (.019)	1150	470 (.219)	672 (3.414)	I
	20° (11.1°)	13.5 (4.0)	1.39 (.088)	.02 (.006)	86.4° (30.2°)					
64L	10° (5.6°)	41.5 (12.2)	8.56 (.540)	.80 (.244)	91.9° (33.3°)	1/20 (.037)	1550	1200 (.560)	1190 (6.045)	II
	20° (11.1°)	34.2 (10.0)	3.53 (.223)	.15 (.046)	86.3° (30.2°)					
	30° (16.7°)	27.0 (7.9)	1.85 (.117)	.04 (.012)	80.7° (27.1°)					
64L*	10° (5.6°)	32.4 (9.5)	6.68 (.421)	.50 (.153)	94.7° (34.8°)	1/20 (.037)	1150	862 (.402)	858 (4.359)	II
	20° (11.1°)	26.9 (7.9)	2.77 (.175)	.09 (.027)	88.7° (31.5°)					
	30° (16.7°)	21.3 (6.2)	1.46 (.092)	.03 (.009)	82.8° (28.2°)					
80L	10° (5.6°)	48.9 (14.3)	10.09 (.637)	.69 (.210)	93.2° (34.0°)	1/20 (.037)	1550	1360 (.635)	1350 (6.858)	II
	20° (11.1°)	40.5 (11.9)	4.17 (.263)	.13 (.040)	87.4° (30.8°)					
	30° (16.7°)	32.0 (9.4)	2.20 (.139)	.04 (.012)	81.7° (27.6°)					
80L*	10° (5.6°)	38.5 (11.3)	7.94 (.501)	.44 (.134)	95.7° (35.4°)	1/20 (.037)	1150	995 (.464)	992 (5.039)	II
	20° (11.1°)	32.0 (9.4)	3.29 (.208)	.08 (.024)	89.6° (32.0°)					
	30° (16.7°)	25.4 (7.4)	1.75 (.110)	.02 (.006)	83.5° (28.6°)					
102L	10° (5.6°)	63.7 (18.7)	13.13 (.828)	1.43 (.463)	93.5° (34.2°)	1/8 (.093)	1070	1752 (.818)	1050 (5.334)	II
	20° (11.1°)	56.5 (16.6)	5.82 (.367)	.31 (.095)	89.7° (32.1°)					
	30° (16.7°)	49.2 (14.4)	3.38 (.213)	.11 (.034)	85.9° (29.9°)					



Hot Water Performance Data

Table 36. Low Output Units Standard Vertical Unit with All Air Ports Open** (continued)

Model No.	Water Temp. Drop °F (°C)	Output MBH (kW)	Flow Rate G.P.M. (L/s)	Press. Drop ft/water m/water	Final Air Temp. °F (°C)	Motor H.P. (kW)	R.P.M.	Nominal CFM (m ³ /s)	Outlet Velocity FPM (m/s)	Sound Rating
102L*	10° (5.6°)	54.5 (16.0)	11.24 (.709)	1.06 (.323)	93.5° (34.2°)	1/8 (.093)	850	1499 (.700)	827 (4.201)	II
	20° (11.1°)	48.5 (14.2)	4.99 (.315)	.23 (.070)	89.8° (32.1°)					
	30° (16.7°)	42.4 (12.4)	2.91 (.184)	.08 (.024)	86.1° (30.1°)					
122L	10° (5.6°)	83.7 (24.5)	17.24 (1.088)	2.40 (.732)	95.4° (35.2°)	1/6 (.124)	1100	2180 (1.017)	1390 (7.061)	III
	20° (11.1°)	73.9 (21.7)	7.62 (.481)	.51 (.156)	91.3° (32.9°)					
	30° (16.7°)	64.2 (18.8)	4.41 (.278)	.18 (.055)	87.1° (30.6°)					
146L	10° (5.6°)	95.4 (28.0)	19.66 (1.240)	2.92 (.891)	97.3° (36.3)	1/6 (.124)	1100	2360 (1.101)	1080 (5.486)	III
	20° (11.1°)	85.5 (25.1)	8.81 (.556)	.65 (.198)	93.4° (34.1)					
	30° (16.7°)	75.6 (22.2)	5.20 (.328)	.24 (.073)	89.5° (31.9)					
166L	10° (5.6°)	112.3 (32.9)	23.15 (1.460)	2.70 (.824)	95.4° (35.2)	1/6 (.124)	1100	2920 (1.363)	1340 (6.807)	IV
	20° (11.1°)	100.7 (29.5)	10.38 (.655)	.60 (.183)	91.8° (33.2)					
	30° (16.7°)	89.2 (26.1)	6.13 (.387)	.22 (.067)	88.1° (31.2)					
202L	10° (5.6°)	135.8 (39.8)	27.98 (1.765)	3.85 (1.174)	96.9° (36.1)	1/4 (.186)	1100	3390 (1.582)	1560 (7.925)	III
	20° (11.1°)	121.8 (35.7)	12.52 (.790)	.85 (.259)	93.0° (33.9)					
	30° (16.7°)	107.3 (31.4)	7.37 (.465)	.32 (.098)	89.2° (31.8)					
252L	10° (5.6°)	168.5 (49.4)	34.72 (2.190)	6.75 (2.059)	94.5° (34.7)	1/4 (.186)	1100	4507 (2.103)	1270 (6.452)	IV
	20° (11.1°)	153.8 (45.1)	15.85 (1.000)	1.56 (.476)	91.4° (33.0)					
	30° (16.7°)	139.1 (40.8)	9.56 (.603)	.61 (.186)	88.4° (31.3)					
280L	10° (5.6°)	188.9 (55.3)	25.95 (1.637)	3.92 (1.196)	94.5° (34.7)	1/2 (.373)	1100	5040 (2.352)	1420 (7.214)	IV
	20° (11.1°)	180.1 (52.8)	18.56 (1.171)	2.10 (.641)	92.9° (33.8)					
	30° (16.7°)	162.7 (47.7)	11.18 (.705)	.82 (.250)	89.7° (32.1)					
336L	10° (5.6°)	220.9 (64.7)	30.35 (1.915)	5.26 (1.604)	95.7° (35.4)	3/4 (.559)	1140	5700 (2.660)	1610 (8.179)	IV
	20° (11.1°)	210.6 (61.7)	21.70 (1.369)	2.81 (.857)	94.1° (34.5)					
	30° (16.7°)	189.9 (55.6)	13.05 (.823)	1.09 (.332)	90.7° (32.6)					
384L	10° (5.6°)	260.7 (76.4)	35.82 (2.260)	5.24 (1.598)	96.4° (35.8)	3/4 (.559)	1140	6600 (3.080)	1870 (9.500)	IV
	20° (11.1°)	248.5 (72.8)	25.61 (1.616)	2.80 (.854)	94.7° (34.8)					
	30° (16.7°)	224.2 (65.7)	15.40 (.971)	1.09 (.332)	91.3° (32.9)					



Hot Water Performance Data

Table 36. Low Output Units Standard Vertical Unit with All Air Ports Open (continued)**

Model No.	Water Temp. Drop °F (°C)	Output MBH (kW)	Flow Rate G.P.M. (L/s)	Press. Drop ft/water m/water	Final Air Temp. °F (°C)	Motor H.P. (kW)	R.P.M.	Nominal CFM (m ³ /s)	Outlet Velocity FPM (m/s)	Sound Rating
500L	20° (11.1°)	310.5 (91.0)	32.00 (2.019)	4.23 (1.290)	90.5° (32.5)	1-1/2 (1.119)	1160	9380 (4.377)	1860 (9.449)	IV
	30° (16.7°)	281.7 (82.5)	19.35 (1.221)	1.67 (.509)	87.7° (30.9)					
600L	10° (5.6°)	394.4 (115.6)	54.19 (3.418)	6.83 (2.083)	95.3° (35.2)	1-1/2 (1.119)	1160	10,300 (4.807)	2060 (10.465)	IV
	20° (11.1°)	377.0 (110.5)	38.85 (2.451)	3.68 (1.122)	93.7° (34.3)					
	30° (16.7°)	342.2 (100.3)	23.51 (1.483)	1.45 (.442)	90.6° (32.6)					
720L	20° (11.1°)	453.7 (132.9)	46.76 (2.950)	4.11 (1.254)	95.1° (35.1)	3 (2.237)	1165	11,900 (5.553)	2380 (12.090)	IV
	30° (16.7°)	411.7 (120.6)	28.28 (1.784)	1.62 (.494)	91.9° (33.3)					

**Performance based on 200° EWT, 20° T.D., 60° E.A.T. Performance at 10° & 30° T.D. is also shown. For capacities at other conditions, use the correction multipliers in the tables on page 17.

*Speed controller option is required for reduced ratings.

Table 37. HOT WATER CALCULATIONS AND CORRECTION FACTOR P STYLE

		EXAMPLE:
		UNIT SIZE _____ 042
		Entering Water Temp. _____ 160°F
		Entering Air Temp. _____ 40°F
		Water Temperature Drop _____ 10°F
I. CAPACITY @ 20° TD:	Read output directly from Table 35 & Table 36 ,	
A. For 200° EWT, 60° EAT	22,700 BTU/HR (Ref., Std. 042, p. 12).	
B. For EWT and/or EAT above or below Standard	Multiply output from Table 35 & Table 36 by factor from Table 38 .	22,700 x .878 = 19,931 BTU/HR.
II. CAPACITY AT OTHER TD's	Multiply output obtained in IA. or IB. (above) by appropriate factor from Table 39	IA - 22,700 x 1.15 = 26,105 BTU/HR. -OR- IB - 19,931 x 1.15 = 22,921 BTU/HR.
A. For TD's from 5 to 60°F		
III. GPM AT OTHER TD's	Multiply GPM of unit for 20° TD, from Table 35 & Table 36 by appropriate factor from Table 39	2.34 x 2.30 = 5.38 GPM (Applies only to units with Std. 200° EWT, 60° EAT.) For all others calculate using formula - GPM = BTU/500 x TD
A. For TD's from 5 to 60°F		
IV. PRESSURE LOSS AT OTHER TD's	Multiply P.D. of unit for 20° TD, from Table 35 & Table 36 by appropriate factor from Table 39	.06 x 5.00 = .30 Ft. H ₂ O
A. For TD's from 5 to 60°F		



Hot Water Performance Data

Table 38. HOT WATER CONVERSION FACTORS BASED ON 200° ENTERING WATER 60° ENTERING AIR 20° TEMPERATURE DROP

ENTERING AIR TEMPERATURE °F (°C)	ENTERING WATER TEMPERATURE -20° WATER TEMPERATURE DROP										
	100° (38°)	120° (49°)	140° (60°)	160° (71°)	180° (82°)	200° (93°)	220° (104°)	240° (116°)	260° (127°)	280° (138°)	300° (149°)
30° (-1)	0.518	0.666	0.814	0.963	1.120	1.268	1.408	1.555	1.702	1.850	1.997
40° (4)	0.439	0.585	0.731	0.878	1.025	1.172	1.317	1.464	1.609	1.755	1.908
50° (10)	0.361	0.506	0.651	0.796	0.941	1.085	1.231	1.375	1.518	1.663	1.824
60° (16)	0.286	0.429	0.571	0.715	0.857	1.000	1.143	1.286	1.429	1.571	1.717
70° (21)	0.212	0.353	0.494	0.636	0.777	0.918	1.060	1.201	1.342	1.483	1.630
80° (27)	0.140	0.279	0.419	0.558	0.698	0.837	0.977	1.117	1.257	1.397	1.545
90° (32)	0.069	0.207	0.345	0.483	0.621	0.759	0.897	1.035	1.173	1.311	1.462
100° (38)	0	0.137	0.273	0.409	0.546	0.682	0.818	0.955	1.094	1.230	1.371

To obtain the BTU capacity for conditions other than those in the basic capacity tables, multiply the basic rating (200° entering water, 60° entering air) by the proper constant from the above tables.

Table 39. HOT WATER BTU, GPM AND PRESSURE LOSS FACTORS BASED ON STANDARD CONDITIONS OF 200°F ENTERING WATER 60°F ENTERING AIR & 20°F WATER DROP

USE FACTORS FROM THIS TABLE TO OBTAIN APPROXIMATE RESULTS	TEMPERATURE DROP °F (°C)									
	5 (3)	10 (6)	15 (8)	20 (11)	25 (14)	30 (17)	40 (22)	50 (28)	60 (33)	
To obtain BTU for other Water Temperature Drops, multiply basic BTU rating by applicable Factor.	1.25	1.15	1.08	1.00	.94	.90	.83	.76	.72	
To obtain GPM for other Water Temperature Drops, multiply basic GPM rating by applicable Factor.*	5.00	2.30	1.44	1.00	.74	.59	.40	.30	.24	
To obtain Pressure Loss Feet of Water for other temperature Drops, multiply Basic loss at 20° drop by Factor.	10.00	5.00	2.00	1.00	.60	.40	.20	.13	.07	

Table 40. *MINIMUM WATER FLOW - GPM

MODEL No.	42	64	80	102	146	166	202	252	336	384
MIN. GPM (L/s)	.55 (.035)	.55 (.035)	.55 (.035)	.55 (.035)	.82 (.052)	.82 (.052)	1.10 (.069)	1.10 (.069)	1.10 (.069)	1.10 (.069)

Table 41. *HEATING CAPACITY FACTORS FOR VARIOUS RATES OF WATER FLOW

% of Rated Water Flow	25%	50%	75%	100%	125%	150%	175%
Btu/Hr Heating Capacity	.80	.89	.96	1.00	1.04	1.07	1.10



Maintenance

Periodic Service

⚠️ WARNING Hazardous Voltage

Open all disconnect switches and secure in that position before servicing unit. Failure to do so may result in personal injury or death from electrical shock.

⚠️ CAUTION Rotating Components

Allow rotating fans to stop before servicing to avoid serious injury to fingers and hands.

Because of the simple design of the steam and hot water unit heaters, they are nearly maintenance free. However, depending on the environment, simple maintenance practices should be adopted.

Periodically check the finned surfaces and vacuum these as often as necessary to remove any accumulation of lint and dirt. Check fan blades and remove dirt accumulation. If fan blades are not cleaned they tend to become unbalanced.

Most of the motors supplied on the unit heaters have either ball bearings or sleeve bearings and should not require lubrication for long periods of time. It is however advisable that motor maintenance and lubrication recommended by the motor manufacturer be followed.

Check motors for dirt and dust accumulation, and remove any accumulation as often as necessary. Open type motors may overheat if the dirt or dust is not removed from ventilation openings.

Motor Lubrication

Sleeve Bearings

Motors with oilers or oil holes are lubricated before shipment with a good grade of electric motor oil. Refill when necessary, with the motor at a stand-still, until oil reaches the proper level.

Use SAE 20W non detergent oil for motors operating in ambient temperatures of 32°F to 100°F (0°C to

38°C). Below 32°F (0°C), SAE 10W non detergent oil will be required.

The frequency of oiling will depend upon operating conditions and length of running time. Inspect the oilers or oil holes when cleaning the unit. If the unit has a fractional horse-power motor, lubricate at least once a year. Under high ambient conditions or constant fan operation, fractional horse-power motors should be lubricated every 90 days. On those motors without oilers or oil holes, follow the instructions given on the motor nameplate.

Ball Bearings

Ball bearing motors are pre-lubricated and normally not equipped with grease fittings. However, motors are equipped with removable grease plugs to allow installation of grease fittings if desired by owner. Motor manufacturers do not recommend or require on the job lubrication of ball bearing motors.

If on the job lubrication is required by the owner, use the following procedure: With the motor at a stand-still, remove the vent and grease plugs. Install grease fitting and add grease sparingly. Remove the old grease from the vent relief chamber. Operate the motor a few minutes before reinstalling the vent plug to allow excess grease to escape. If there is evidence of grease working out around the motor shaft, less grease should be added and the greasing periods lengthened. If grease continues to appear, take the motor to the motor manufacturer's authorized service station for repair.

Note: Consult local motor manufacturer's service facility for information on type of grease and oil to be used.

Note: The heater system should be checked once a year by a qualified technician. All maintenance/service information should be recorded accordingly on the

inspection sheet provided in this manual.

Should maintenance be required, perform the following inspection and service routine:

Inspect the area near the unit to be sure that there is no combustible material located within the minimum clearance requirements listed in this manual.

Cleaning the Unit

The unit casing, fan, diffuser and coil should be cleaned thoroughly once a year. Coil heat transfer efficiency depends on cleanliness. The following recommended procedures may be performed when lubricating the motor and cleaning the coil.

1. Wipe all excess lubricant from the motor, fan and casing. Clean the motor thoroughly. A dirty motor will run hot and eventually cause internal damage.
2. Clean the coil:
 - a. Loosen the dirt with a brush on the fan side of the coil. Operate the motor allowing the fan to blow the loosened dirt through the unit.
 - b. Use high pressure air or steam on the side of the coil away from the fan.

Note: A piece of cheesecloth or a burlap bag may be used to collect the large particles during the cleaning process.

3. Clean the casing, fan blades, fan guard and diffuser using a damp cloth. Any rust spots on the casing should be cleaned and repainted.
4. Tighten the fan guard, motor frame and fan bolts. Check the fan for clearance in the panel orifice and free rotation.

Table 42. Troubleshooting Guide

Symptoms	Possible Cause(s)	Corrective Action
A. Leaking coil	<ol style="list-style-type: none"> 1. Frozen coil. 2. Defective coil. 3. Corrosion. 4. Leak in joint. 	<ol style="list-style-type: none"> 1. Replace. 2. Replace. 3. Replace 4. Braze joint if joint is exposed where leak has occurred.
B. Poor output on steam	<ol style="list-style-type: none"> 1. Check for air in coil. 2. Lint on coil fins 	<ol style="list-style-type: none"> 1. Repair or replace thermostatic air vent. 2. Clean coil and fins. Check filter and clean.
C. Poor output on steam or hot water	<ol style="list-style-type: none"> 1. No circulation of water through coil. 2. Short cycling of motor. 3. Backward rotating motor. 	<ol style="list-style-type: none"> 1. Check circulation pump. Check for blocked tubes. 2. Check voltage and correct. Check for linted coil and clean. Check for defective overload and repair or replace motor. 3. On single phase motor replace motor. On three phase motor, reverse two leads to change rotation.
D. Noisy or vibrating unit	<ol style="list-style-type: none"> 1. Damaged fan blade. 2. Dirty fan blade. 	<ol style="list-style-type: none"> 1. Change fan blade. 2. Clean fan blade.

Table 43. Unit Equipment Start-Up

Customer _____ Job Name & Number _____

Pre-Inspection Information (with power off)

Type of equipment: Unit Heater _____

Serial Number _____ Model Number _____

Name Plate Voltage _____ Name Plate Amperage _____

Steam _____ Hotwater _____

Questions/Checklist

Are all panels in place? _____

Has the unit suffered any external damage? If so, what: _____

Does the piping and electric wiring appear to be installed in a professional manner? _____

Has the piping and electric been inspected by the local authority having jurisdiction? _____

Is the supply properly sized for the equipment? _____

Were the installation instructions followed when the equipment was installed? _____

Have all field installed controls been installed? _____

Do you understand all the controls on this equipment? _____

Additional "P" Model Instructions

Fan and Motor Assembly

For cleaning or maintenance purposes, the fan and motor assembly may be removed easily from the Unit Heater. The motor is attached to the fan guard which is, in turn, mounted to the top or back panel of the unit as shown in [Figure 58](#).

On Vertical Units, reach up through the fan and remove the fan guard mounting screws. Lower the motor, fan and fan guard assembly down through the fan outlet. If desired, the top and bottom panels may be removed from the coil by taking out

the four panel mounting bolts. See [Figure 58](#).

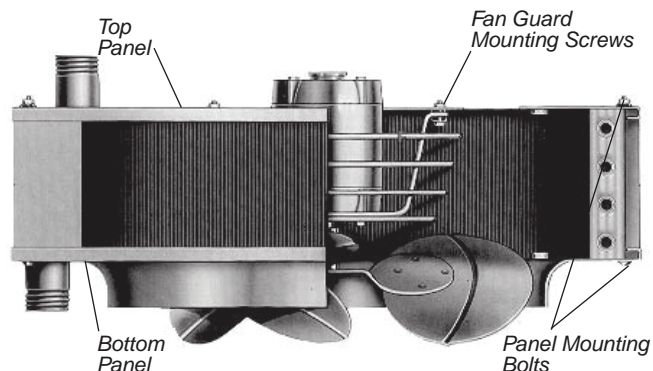
Figure 58. Cross Section View



Warranty Info

LIMITED WARRANTY: S Model

HORIZONTAL STEAM & HOT WATER UNIT HEATERS

The Manufacturer warrants to the original owner at the original installation site that the Horizontal Steam and Hot Water Unit Heaters (the "Product") will be free from defects in material and workmanship for a period not to exceed one (1) year from startup or eighteen (18) months from date of shipment from the factory, whichever occurs first. If upon examination by the Manufacturer the Product is shown to have a defect in material or workmanship during the warranty period, the Manufacturer will repair or replace, at its option, that part of the Product which is shown to be defective.

This limited warranty does not apply:

- a. if the Product has been subjected to misuse or neglect, has been accidentally or intentionally damaged, has not been installed, maintained or operated in accordance with the furnished written instructions, or has been altered or modified in any way.
- b. to any expenses, including labor or material, incurred during removal or reinstallation of the defective Product or parts thereof.
- c. to any workmanship of the installer of the Product.

This limited warranty is conditional upon:

- a. shipment, to the Manufacturer, of that part of the Product thought to be defective. Goods can only be returned with prior written approval from the Manufacturer. All returns must be freight prepaid.
- b. determination, in the reasonable opinion of the Manufacturer, that there

exists a defect in material or workmanship.

Repair or replacement of any part under this Limited Warranty shall not extend the duration of the warranty with respect to such repaired or replaced part beyond the stated warranty period.

THIS LIMITED WARRANTY IS IN LIEU OF ALL OTHER WARRANTIES, EITHER EXPRESS OR IMPLIED, AND ALL SUCH OTHER WARRANTIES, INCLUDING WITHOUT LIMITATION IMPLIED WARRANTIES OF MERCHANTABILITY OR FITNESS FOR A PARTICULAR PURPOSE, ARE HEREBY DISCLAIMED AND EXCLUDED FROM THIS LIMITED WARRANTY. IN NO EVENT SHALL THE MANUFACTURER BE LIABLE IN ANY WAY FOR ANY CONSEQUENTIAL, SPECIAL, OR INCIDENTAL DAMAGES OF ANY NATURE WHATSOEVER, OR FOR ANY AMOUNTS IN EXCESS OF THE SELLING PRICE OF THE PRODUCT OR ANY PARTS THEREOF FOUND TO BE DEFECTIVE. THIS LIMITED WARRANTY GIVES THE ORIGINAL OWNER OF THE PRODUCT SPECIFIC LEGAL RIGHTS. YOU MAY ALSO HAVE OTHER RIGHTS WHICH MAY VARY BY EACH JURISDICTION.

LIMITED WARRANTY: P Model

VERTICAL STEAM & HOT WATER UNIT HEATERS

The Manufacturer warrants to the original owner at the original installation site that the Vertical Steam and Hot Water Unit Heaters (the "Product") will be free from defects in material and workmanship for a period not to exceed one (1) year from startup or eighteen (18) months from date of shipment from the factory, whichever occurs first. If upon examination by the Manufacturer the Product is shown to have a defect in material or workmanship during the warranty period, the Manufacturer will repair or replace, at its option, that part of the Product which is shown to be defective.

This limited warranty does not apply:

- a. if the Product has been subjected to misuse or neglect, has been accidentally or intentionally damaged, has not been installed, maintained or operated in accordance with the furnished written instructions, or has been altered or modified in any way.
- b. to any expenses, including labor or material, incurred during removal or reinstallation of the defective Product or parts thereof.
- c. to any workmanship of the installer of the Product.

This limited warranty is conditional upon:

- a. shipment, to the Manufacturer, of that part of the Product thought to be defective. Goods can only be returned with prior written approval from the Manufacturer. All returns must be freight prepaid.
- b. determination, in the reasonable opinion of the Manufacturer, that there exists a defect in material or workmanship.

Repair or replacement of any part under this Limited Warranty shall not extend the duration of the warranty with respect to such repaired or replaced part beyond the stated warranty period.

THIS LIMITED WARRANTY IS IN LIEU OF ALL OTHER WARRANTIES, EITHER EXPRESS OR IMPLIED, AND ALL SUCH OTHER WARRANTIES, INCLUDING WITHOUT LIMITATION IMPLIED WARRANTIES OF MERCHANTABILITY OR FITNESS FOR A PARTICULAR PURPOSE, ARE HEREBY DISCLAIMED AND EXCLUDED FROM THIS LIMITED WARRANTY. IN NO EVENT SHALL THE MANUFACTURER BE LIABLE IN ANY WAY FOR ANY CONSEQUENTIAL, SPECIAL, OR INCIDENTAL DAMAGES OF ANY NATURE WHATSOEVER, OR FOR ANY AMOUNTS IN EXCESS OF THE



Warranty Info

SELLING PRICE OF THE PRODUCT OR ANY PARTS THEREOF FOUND TO BE DEFECTIVE. THIS LIMITED WARRANTY GIVES THE ORIGINAL OWNER OF THE PRODUCT SPECIFIC LEGAL RIGHTS. YOU MAY ALSO HAVE OTHER RIGHTS WHICH MAY VARY BY EACH JURISDICTION.



www.trane.com

For more information, contact your local Trane office or e-mail us at comfort@trane.com

Digitally printed on environmentally friendly paper, produced using fewer trees and chemicals and less energy.



Literature Order Number	UH-SVX01A-EN
Date	September 2008
Supersedes	UH-SVX01A-EN July 2008

Trane has a policy of continuous product and product data improvement and reserves the right to change design and specifications without notice.