



Installation, Operation, and Maintenance

IntelliCore™ Split Systems

Cooling Condensers – 20 to 120 Tons
Remote Chillers – 20 to 120 Tons



Models: RAUK-C20
RAUK-C25
RAUK-C30
RAUK-C40
RAUK-C50
RAUK-C60
RAUK-C80
RAUK-D10
RAUK-D12

⚠ SAFETY WARNING

Only qualified personnel should install and service the equipment. The installation, starting up, and servicing of heating, ventilating, and air-conditioning equipment can be hazardous and requires specific knowledge and training. Improperly installed, adjusted or altered equipment by an unqualified person could result in death or serious injury. When working on the equipment, observe all precautions in the literature and on the tags, stickers, and labels that are attached to the equipment.



Introduction

Read this manual thoroughly before operating or servicing this unit.

Warnings, Cautions, and Notices

Safety advisories appear throughout this manual as required. Your personal safety and the proper operation of this machine depend upon the strict observance of these precautions.

The three types of advisories are defined as follows:



Indicates a potentially hazardous situation which, if not avoided, could result in death or serious injury.



Indicates a potentially hazardous situation which, if not avoided, could result in minor or moderate injury. It could also be used to alert against unsafe practices.



Indicates a situation that could result in equipment or property-damage only accidents.

Important Environmental Concerns

Scientific research has shown that certain man-made chemicals can affect the earth's naturally occurring stratospheric ozone layer when released to the atmosphere. In particular, several of the identified chemicals that may affect the ozone layer are refrigerants that contain Chlorine, Fluorine and Carbon (CFCs) and those containing Hydrogen, Chlorine, Fluorine and Carbon (HCFCs). Not all refrigerants containing these compounds have the same potential impact to the environment. Trane advocates the responsible handling of all refrigerants.

Important Responsible Refrigerant Practices

Trane believes that responsible refrigerant practices are important to the environment, our customers, and the air conditioning industry. All technicians who handle refrigerants must be certified according to local rules. For the USA, the Federal Clean Air Act (Section 608) sets forth the requirements for handling, reclaiming, recovering and recycling of certain refrigerants and the equipment that is used in these service procedures. In addition, some states or municipalities may have additional requirements that must also be adhered to for responsible management of refrigerants. Know the applicable laws and follow them.

⚠ WARNING

Proper Field Wiring and Grounding Required!

Failure to follow code could result in death or serious injury.

All field wiring **MUST** be performed by qualified personnel. Improperly installed and grounded field wiring poses **FIRE** and **ELECTROCUTION** hazards. To avoid these hazards, you **MUST** follow requirements for field wiring installation and grounding as described in **NEC** and your local/state/national electrical codes.

⚠ WARNING

Personal Protective Equipment (PPE) Required!

Failure to wear proper PPE for the job being undertaken could result in death or serious injury.

Technicians, in order to protect themselves from potential electrical, mechanical, and chemical hazards, **MUST** follow precautions in this manual and on the tags, stickers, and labels, as well as the instructions below:

- **Before installing/servicing this unit, technicians MUST put on all PPE required for the work being undertaken (Examples; cut resistant gloves/sleeves, butyl gloves, safety glasses, hard hat/bump cap, fall protection, electrical PPE and arc flash clothing). ALWAYS refer to appropriate Safety Data Sheets (SDS) and OSHA guidelines for proper PPE.**
- **When working with or around hazardous chemicals, ALWAYS refer to the appropriate SDS and OSHA/GHS (Global Harmonized System of Classification and Labelling of Chemicals) guidelines for information on allowable personal exposure levels, proper respiratory protection and handling instructions.**
- **If there is a risk of energized electrical contact, arc, or flash, technicians MUST put on all PPE in accordance with OSHA, NFPA 70E, or other country-specific requirements for arc flash protection, PRIOR to servicing the unit. NEVER PERFORM ANY SWITCHING, DISCONNECTING, OR VOLTAGE TESTING WITHOUT PROPER ELECTRICAL PPE AND ARC FLASH CLOTHING. ENSURE ELECTRICAL METERS AND EQUIPMENT ARE PROPERLY RATED FOR INTENDED VOLTAGE.**

⚠ WARNING**Follow EHS Policies!**

Failure to follow instructions below could result in death or serious injury.

- All Trane personnel must follow the company's Environmental, Health and Safety (EHS) policies when performing work such as hot work, electrical, fall protection, lockout/tagout, refrigerant handling, etc. Where local regulations are more stringent than these policies, those regulations supersede these policies.
- Non-Trane personnel should always follow local regulations.

⚠ WARNING**R-454B Flammable A2L Refrigerant!**

Failure to use proper equipment or components as described below could result in equipment failure, and possibly fire, which could result in death, serious injury, or equipment damage.

The equipment described in this manual uses R-454B refrigerant which is flammable (A2L). Use **ONLY** R-454B rated service equipment and components. For specific handling concerns with R-454B, contact your local representative.

⚠ WARNING**Cancer and Reproductive Harm!**

This product can expose you to chemicals including lead and bisphenol A (BPA), which are known to the State of California to cause cancer and birth defects or other reproductive harm. For more information go to www.P65Warnings.ca.gov.

⚠ WARNING**Refrigerant under High Pressure!**

Failure to follow instructions below could result in an explosion which could result in death or serious injury or equipment damage.

System contains refrigerant under high pressure. Recover refrigerant to relieve pressure before opening the system. See unit nameplate for refrigerant type. Do not use non-approved refrigerants, refrigerant substitutes, or refrigerant additives.

⚠ WARNING**Explosion Hazard!**

Failure to follow instructions below could result in an explosion which could result in death or serious injury, and equipment damage.

NEVER bypass system safeties in order to pump down the unit component's refrigerant into the microchannel heat exchanger (MCHE) coil. Do **NOT** depress the compressor contactor since it effectively bypasses the high-pressure control.

⚠ WARNING**R-410A Refrigerant under Higher Pressure than R-22!**

Failure to use proper equipment or components as described below, could result in equipment failing and possibly exploding, which could result in death, serious injury, or equipment damage.

The units described in this manual use R-410A refrigerant which operates at higher pressures than R-22. Use **ONLY** R-410A rated service equipment or components with these units. For specific handling concerns with R-410A, please contact your local Trane representative.

Copyright

This document and the information in it are the property of Trane, and may not be used or reproduced in whole or in part without written permission. Trane reserves the right to revise this publication at any time, and to make changes to its content without obligation to notify any person of such revision or change.

Trademarks

All trademarks referenced in this document are the trademarks of their respective owners.

Revision History

- Added Digit 27 to the Model Number Description chapter.
- Updated the General data IntelliCore condensing units table in General Information chapter.
- Updated figures in Dimensions and Weights chapter.
- Added expansion valve selection, any BPHE all fin and tube OD coils (0% bleed) and Expansion valve selection, 20 to 60 ton MCHE (30% bleed) tables to Installation Mechanical chapter.
- Added IntelliCore electrical data (R-410A) table to Installation Electrical chapter.
- Updated the Operating Principles chapter.
- Added thermal expansion valve manufacturer settings for no-bleed Emerson and Danfoss applications.



Table of Contents

Model Number Description	7	Unit Mounting	50
General Information	8	Unit Isolation	51
Unit Inspection	8	Neoprene Isolators (20 to 60 Ton units)	51
Exterior Inspection	8	Spring Isolators (20 to 120 Ton units)	52
Inspection for Concealed Damage	8	Installation	53
Repair	8	General Unit Requirements	53
Nameplates	8	Refrigerant Piping Requirements	53
Unit Nameplate	8	Refrigerant Piping Components	53
Compressor Nameplate	8	Refrigerant Piping	57
EVP Chiller — Applications Only	8	Typical Field-Installed Evaporator Piping: Dual-Circuit Examples	58
Phase Monitor	8	Hot Gas Bypass for Commercial Comfort-Cooling Applications	59
Electronic Compressor Protection Module (CPM)	9	Optional Pressure Gauges	60
Unit Description	9	Final Refrigerant Pipe Connections	60
General Data	10	Brazing Procedures	60
A2L Information	12	Leak Testing Procedure	61
.....	12	Installation Mechanical — EVP	63
A2L Work Procedures	12	EVP Chilled Water Piping Requirements	63
Servicing	12	TXV for Remote Chiller	63
Leak Detection	13	Typical Field-Installed EVP Chiller Evaporator Piping	63
Refrigerant Removal and Evacuation	13	Remote EVP Chiller	64
Refrigerant Charging	14	Water Treatment	64
Decommissioning	14	Water Flow Limits	64
A2L Application Considerations	14	Water Temperature Limits	64
Ignition Sources in Unit	15	Short Water Loops	64
Minimum Room Area Limits (Refrigerant charge greater than 3.91 lb per circuit)	15	Chilled Water Piping	65
Field Piping Installation and Charging	16	Final Water Piping Connections	68
Dimensions and Weights	17	Installation Electrical	69
Unit Clearances	17	Electrical	69
Unit Dimensions	19	Wiring Requirements	72
Unit Weights	47	Main Unit Power Wiring	72
Installation Mechanical	48	Disconnect Switch with External Handle	73
Location Requirements	48	250A Disconnect Switch Wire Binding Screws	73
Isolation	48	Controls Wiring	73
Foundation	48	Refrigerant Leak Detection Input	74
Leveling the Unit	48	24V Transformer	74
Rigging and Lifting	48		

EVP Chiller Control	75	EVP Chiller Applications	99
Operating Principles	76	Freezestat Setting	99
Component Locations	76	System Airflow Verification	99
Condenser Fans	76	Preliminary Expansion Valve	
Compressors	77	Adjustment	99
Sequence of Operations	77	Adding Preliminary Charge	100
Auto/Stop	77	Compressor Start-Up (All Systems)	101
Power Up Start Display	78	Subcooling	105
Fan/Pump Interlock	79	Measuring Superheat	105
No System Control	79	Compressor Oil	106
Discharge Temperature Control	79	Compressor Crankcase Heaters	106
EVP Temperature Control	79	Compressor Sequencing	106
Remote Setpoint	79	Pressure Curves	107
Adaptive Control	80	Final System Setup	111
Frost Protection	87	Maintenance	113
Freeze Protections - EVP System		Monthly Maintenance	113
Control	88	Air Handling Equipment	113
Hot Gas Bypass (Coil Frost		Condensing Unit	113
Protection)	89	Coil Cleaning	113
Liquid Line Valve Control	90	Microchannel Condenser Coil Repair	
Control Box Ventilation Fan		and Replacement	114
Control	90	EVP Remote Evaporator Chiller	114
Integrated Economizing	90	Water Strainer Maintenance	114
Outdoor Air Damper Fault		EVP Evaporator Replacement	114
Detection	92	Water Loop	114
Rapid Restart	92	Scroll Compressor	115
Refrigerant (R-454B) Leak		Operational Sounds	115
Detection	93	Failure Diagnosis and	
Discharge Air Reset	93	Replacement	115
Demand Limit	94	Refrigerant Evacuation and	
Operating Modes	94	Charging	115
Communication Protocol	94	Compressor Replacement	116
Thermostatic Expansion Valve	94	YAS 2-Stage Compressors (20 and 25	
Compressor Crankcase Heaters	95	Ton)	116
Pre-Start	96	CSHE/CSHD Compressors (30 to 60	
EVP Chiller Applications	96	Ton)	116
System Evacuation Procedures	96	CSHP/CSHN Compressors (80 to 120	
Standing Vacuum Test	97	Ton)	117
Voltage Imbalance	98	Suction Line Filter	118
Electrical Phasing	98	Fall Restraint — Condenser Roof	118
Start-Up	99	Warranty and Liability Clause	120
Low Ambient Damper Adjustment (Factory		Commercial Equipment Rated 20 Tons and	
or Field Installed)	99	Larger and Related Accessories	120



Table of Contents

Products Covered..... 120

Wiring Diagrams..... 121



Model Number Description

Digit 1 — Unit Type

R = Remote Condenser

Digit 2 — Condenser

A = Air-Cooled

Digit 3 — System Type

U = Upflow

Digit 4 — Development Sequence

K = Fourth

Digit 5, 6, 7 — Nominal Capacity

C20 = 20 Tons

C25 = 25 Tons

C30 = 30 Tons

C40 = 40 Tons

C50 = 50 Tons

C60 = 60 Tons

C80 = 80 Tons

D10 = 100 Tons

D12 = 120 Tons

Digit 8 — Voltage and Start Characteristics

E = 200/60/3

F = 230/60/3

4 = 460/60/3

5 = 575/60/3

* = 380/50/3

* = 415/50/3

Digit 9 — System Controls

B = No System Control

E = Supply Air VAV Control

P = EVP Control

Digit 10 — Design Sequence

Factory Assigned

Digit 11 — Ambient Control

0 = Standard

1 = 0°F (Low Ambient Option)

Digit 12 — Agency Approval

0 = None

3 = cULus (60 Hz only)

Digit 13 — Disconnect Switch

0 = None

A = Unit Mounted Disconnect Switch with Standard Fault SCCR

B = Unit Mounted Disconnect Switch with High Fault SCCR

Digit 14 — Hot-Gas Bypass Valve

0 = None

B = Hot-Gas Bypass Valve

Digit 15 — Suction Service Valve

0 = None

D = Suction Service Valve

Digit 16 — Pressure Gauges

0 = None

F = Pressure Gauges and Piping

Digit 17 — IBC Compliance

0 = None

1 = IBC Compliance

Digit 18 — Corrosion Protected Condenser Coil

0 = None

J = Corrosion Protected Condenser Coil

Digit 19 — Options

0 = None

C = Remote Chiller Evaporator and Install Kit

T = Flow Switch (EVP Control Only)

Digit 20 — Isolators

0 = None

1 = Spring Isolator

2 = Neoprene Isolators

Digit 21 — Powered and Unpowered Convenience Outlet

0 = None

1 = Powered 15A Convenience Outlet

2 = Unpowered 20A Convenience Outlet

Digit 22 — TD-7 and Wi-Fi Adapter

0 = None

1 = Wi-Fi Adapter

2 = TD-7

3 = Wi-Fi Adapter and TD-7

Digit 23 — Communication Protocol

0 = None

1 = BACnet®

2 = Modbus®

Digit 24 — Rapid Restart

0 = None

1 = Rapid Restart

Digit 25 — Integrated Economizer Controls

0 = None

1 = Economizer Control with Dry Bulb

Digit 26 — Expansion Module

0 = None

1 = Expansion Module

Notes:

1. The service digit for each model number contains 26 digits. All 26 digits must be referenced.

2. * = Design special.

Digit 27 — Refrigerant Type

A = R-410A

B = R-454B



General Information

Unit Inspection

To protect against loss due to damage incurred in transit, perform inspection immediately upon receipt of the unit.

Exterior Inspection

If the job site inspection reveals damage or material shortages, file a claim with the carrier immediately. Specify the type and extent of the damage on the bill of lading before signing. Notify the appropriate sales representative.

Important: Do not proceed with installation of a damaged unit without sales representative's approval.

- Visually inspect the complete exterior for signs of shipping damages to unit or packing material.
- Verify that the nameplate data matches the sales order and bill of lading.
- Verify that the unit is properly equipped and there are no material shortages.
- Verify that the power supply complies with the unit nameplate specifications.

Inspection for Concealed Damage

Visually inspect the components for concealed damage as soon as possible after delivery and before it is stored.

Do NOT walk on the sheet metal base pans. Bridging between the unit's main supports may consist of multiple 2 by 12 boards or sheet metal grating.

⚠ WARNING

No Step Surface!

Failure to follow instruction below could result in death or serious injury.

Do not walk on the sheet metal drain pan. Walking on the drain pan could cause the supporting metal to collapse and result in the operator/technician falling.

If concealed damage is discovered:

- Notify the carrier's terminal of the damage immediately by phone and by mail.
- Concealed damage must be reported within 15 days.
- Request an immediate, joint inspection of the damage with the carrier and consignee.
- Stop unpacking the unit.
- Do not remove damaged material from receiving location.
- Take photos of the damage, if possible.
- The owner must provide reasonable evidence that the damage did not occur after delivery.

Repair

Notify the appropriate sales representative before arranging unit installation or repair.

Important: Do not repair unit until the damage has been inspected by the carrier's representative.

Nameplates

Unit Nameplate

One Mylar unit nameplate is located on the outside upper right corner of the control panel door. It includes the unit model number, serial number, electrical characteristics, weight, refrigerant charge, as well as other pertinent unit data. A small metal nameplate with model number, serial number, and unit weight is located just above the Mylar nameplate, and a third nameplate is located on the inside of the control panel door.

When ordering replacement parts or requesting service, be sure to refer to the specific model number, serial number, and DL number (if applicable) stamped on the unit nameplate.

Compressor Nameplate

The nameplate for the scroll compressors is located on the lower housing of the compressor.

EVP Chiller — Applications Only

If ordered with remote EVP chiller kit, piping components ship in condenser section. The heat exchanger ships separately. Location of nameplate depends on size.

- 20 to 30 ton chiller: same side as water connections near center left.
- 40 to 120 ton chiller: same side as water connections near bottom.

To view nameplate, raise insulation flap over nameplate. Replace and retape insulation flap after viewing.

Phase Monitor

This sensor monitors voltage between the three conductors of the three-phase power supply. Two LED lights are provided:

- The green light indicates that a balanced three-phase supply circuit is properly connected.
- The red light indicates that unit operation has been prevented. There are two conditions that will prevent unit operation:
 - The power supply circuit is not balanced with the proper phase sequence of L1, L2, L3 for the three conductors of a three-phase circuit.
 - The line-to-line voltage is not between 180 volts and 633 volts.

Electronic Compressor Protection Module (CPM)

The CSHN and CSHP compressors come equipped with a compressor protection module (CPM) capable of detecting phase reversal, phase loss, and motor overheating. When a fault is identified, the output relay will open. Depending on the fault, the CPM may either auto-reset or it may lock out. The CPM can be manually reset by cycling control power.

Note: *If the compressor has tripped due to an overheated windings condition, the motor winding temperature sensor resistance (PTC) will be 4500 ohms or greater; the resistance must be less than 2750 ohms before the five minute reset timer becomes enabled.*

Unit Description

All air cooled condensing units are designed for outdoor installations with vertical air discharge. These units may be installed on a flat roof or placed on a concrete slab at ground level.

Before shipment, each unit is leak-tested, evacuated, a nitrogen holding charge is added, and the controls are tested for proper operation.

The condenser coils are all-aluminum microchannel design. Corrosion protected condenser coils are a standard option. Louvered condenser grilles for coil protection are standard. Direct-drive, vertical discharge condenser fans are provided with built-in current and overload protection.

If low ambient operation is required, low ambient dampers are available as a field or factory installed option.

Units may be ordered with one of the following options:

- No System Controls (Field provided controls required)
- Supply Air Temperature Control (VAV applications)
- EVP Controls

Basic unit components include:

- Manifolded scroll compressors
- Condenser coils
- Condenser fans (number based on unit size)
- Discharge service valve (one per circuit)

Electrical schematics and device location diagrams are located inside the control panel access door.



General Information

General Data

Table 1. General data — IntelliCore condensing units

Unit Size (tons)		20	25	30	40	50	60	80	100	120
Compressor Data										
Type		Scroll								
Number of Refrigerant Circuits		1	1	1	2	2	2	2	2	2
Manifolded Compressor sizes ^(a) :R-410A	Tons	10-10	10-13.5	15-15	10-10	11.5-13.5	15-15	15-15-15	15-15-20	20-20-20
Manifolded Compressor sizes ^(a) :R-454B	Tons	12.8-8.7 ^(b)	15.2-10.2 ^(b)	7.4-11.3-11.3	9.8-11.3	11.3-12.3	14.9-14.9	15-15-15	15-15-20.5	20.5-20.5-20.5
Unit Capacity Steps : R-410A	%	100-50	100-42	100-50	100-75-50-25	100-73-46-23	100-75-50-25	100-83-66-50-33-17	100-80-60-45-30-15	100-83-66-50-33-17
Unit Capacity Steps : R-454B	%	100-82-40-23	100-82-60-40-22	100-75-62-38-25	100-73-46-23	100-74-48-24	100-75-50-25	100-83-66-50-33-17	100-80-59-45-30-15	100-83-66-50-33-17
Condenser Fan Data										
Type/Drive Type		Prop/Direct								
Qty		2	3	3	4	6	6	8	12	12
Diameter	in	26	26	26	26	26	26	26	26	26
Power/motor	hp	1.0	1.0	1.0	1.0	1.0	1.0	1.0	1.0	1.0
Nominal Total Airflow	cfm	14600	20700	20700	26790	36890	40490	56490	73890	76280
Condenser Coil Data										
Type		Microchannel								
Number of Coils		2	2	2	2	2	2	4	4	4
Size	in	42x71	42x71	42x71	59x71	51x96	51x96	59x71	51x96	64x96
Face Area	ft ²	41.4	41.4	41.4	58.2	68.0	68.0	116.4	136.0	170.7
Rows/Fin Per Ft.		1/240	1/240	1/240	1/240	1/240	1/240	1/240	1/240	1/240
Storage Capacity ^(c) : R-410A	lbs	18.7	18.7	18.7	23.5	25	25	47.1	50	62.9
Storage Capacity ^(c) : R-454B	lbs	11.5	11.5	11.5	22.9	23.9	23.9	45.7	47.8	60.2
Refrigerant Data^(d)										
Operating Charge ^(e) : R-410A	lbs	11.9	11.8	11.8	22.7	23.4	23.8	57.1	59.1	65.3
Operating Charge ^(e) : R-454B	lbs	6.8	6.7	8.0	13.8	14.0	14.7	38.2	38.2	41.1
Outdoor Air Temperature for Mechanical Cooling										
Standard Ambient Operating Range ^(f)	°F	40-125	40-125	40-125	40-125	40-125	40-125	40-125	40-125	40-125
Low Ambient Option	°F	0-125	0-125	0-125	0-125	0-125	0-125	0-125	0-125	0-125

^(a) Circuit 1 compressor manifold sizes shown. For units with 2 circuits, compressor manifold set is the same for circuit 1 and 2.

^(b) 2-stage compressor.

^(c) Condenser storage capacity is given at conditions of 95°F outdoor temperature, and 95% full.

^(d) Refer to Refrigerant Piping in the Application Considerations section. Condensing units are shipped with nitrogen holding charge only.

^(e) Operating charge is approximate for condensing unit only, and does not include charge for low side or interconnecting lines. Condensing units are shipped with a nitrogen holding charge only.

^(f) Maximum operating ambient for EVP remote chillers is 115°F.

Table 2. Altitude correction multiplier for capacity

Configuration	Altitude (ft.)				
	2,000	4,000	6,000	8,000	10,000
Condensing Unit Only	0.982	0.960	0.933	0.902	0.866
Condensing Unit / Air Handling Unit Combination	0.983	0.963	0.939	0.911	0.881
Condensing Unit With Evaporator	0.986	0.968	0.947	0.921	0.891



A2L Information

This section applies only to units with R-454B refrigerant (model number digit 27 = B).

A2L Work Procedures

⚠ WARNING

Risk of Fire — Flammable Refrigerant!
Failure to follow instructions below could result in death or serious injury, and equipment damage.

- To be repaired only by trained service personnel.
- Do not puncture refrigerant tubing.
- Dispose of properly in accordance with federal or local regulations.
- The equipment shall be stored in a room without continuously operating ignition sources.

⚠ WARNING

Refrigerant under High Pressure!
Failure to follow instructions below could result in an explosion which could result in death or serious injury or equipment damage.
System contains refrigerant under high pressure. Recover refrigerant to relieve pressure before opening the system. See unit nameplate for refrigerant type. Do not use non-approved refrigerants, refrigerant substitutes, or refrigerant additives.

⚠ WARNING

Hazardous Voltage!
Failure to disconnect power before servicing could result in death or serious injury.
Disconnect all electric power, including remote disconnects before servicing. Follow proper lockout/tagout procedures to ensure the power can not be inadvertently energized. Verify that no power is present with a voltmeter.

The units described in this manual use R-454B refrigerant. Use ONLY R-454B rated service equipment or components with these units. For specific handling concerns with R-454B, contact your local Trane representative.

Installation, repair, removal, or disposal should be performed by trained service personnel.

At all times, Trane’s maintenance and service guidelines shall be followed. If in doubt, contact Trane technical support for assistance.

Servicing

Prior to initiating work on equipment, check the area with an appropriate refrigerant detector. Ensure the service personnel are properly trained regarding work in potentially toxic or flammable atmospheres. Ensure that the leak detection equipment being used is suitable for use with all applicable refrigerants, i.e. non-sparking, adequately sealed, or intrinsically safe. Be aware that the refrigerant does not contain an odor.

If any hot work is to be conducted on the refrigerating equipment or any associated parts, appropriate fire extinguishing equipment shall be available on hand. A dry powder or CO₂ fire extinguisher should be located adjacent to the charging area.

At all times, Trane’s maintenance and service guidelines shall be followed. If in doubt, contact Trane technical support for assistance.

All maintenance staff and others working in the local area shall be instructed on the nature of the work being carried out. Work in confined spaces shall be avoided.

Ignition Source Mitigation

Do not use any sources of ignition when working on the refrigeration system.

Keep all ignition sources, including cigarette smoking, away from the site of installation, repair, removal or disposal, during which refrigerant can potentially be released to the surrounding space.

Survey the area around the equipment before initiating work to ensure no flammable hazards or ignition risks are present.

“No Smoking” signs shall be displayed.

Do not use devices that can be a source of ignition to accelerate defrosting of components. Use only defrost and cleaning procedures recommended by Trane. Do not pierce or burn.

Ventilation

Ensure that the area is in the open or that it is adequately ventilated before breaking into the system or conducting any hot work. A degree of ventilation shall continue during the period that the work is carried out. The ventilation should safely disperse any released refrigerant and preferably expel it externally into the atmosphere. If present, check that the ventilation system, including outlets, are operating adequately and are not obstructed.

Refrigerating Equipment

Refrigerant piping or components should not be installed in locations where substances which may corrode them are present.

Check that equipment hazard markings are visible and legible. Replace them if they are not.

For equipment using secondary fluids, like water or glycol, check that refrigerant is not present in the secondary fluid loop before conducting any hot work.

Electrical Devices

Do not apply power to the circuit if a fault exists which compromises safety. If the fault cannot be corrected immediately, but it is necessary to continue operation, an adequate temporary solution shall be used. This shall be reported to the owner of the equipment, so all parties are advised.

Initial safety checks shall include:

- Cabling is not subject to wear, corrosion, excessive pressure, vibration, sharp edges, or any other adverse environmental effects. Account for the effects of aging or continual vibration from sources such as compressors or fans.
- Capacitors are discharged. This shall be done in a safe manner to avoid possibility of sparking.
- No live electrical components and wiring are exposed while charging, recovering, or purging the system.
- Verify continuity of earth bonding.
- Replace electrical components with Trane replacement parts, or those meeting the same ratings and qualified for flame arrest protection, UL LZGH2 category.

Leak Detection

Never use an open flame to detect leaks. A halide torch should not be used. Use only approved leak detection methods per this instruction manual.

The following leak detection methods are deemed acceptable for all refrigerant systems.

Electronic leak detectors may be used to detect refrigerant leaks but, in the case of flammable refrigerants, the sensitivity may not be adequate, or may need re-calibration. (Detection equipment shall be calibrated in a refrigerant-free area.) Verify the detector is not a potential source of ignition and is suitable for the refrigerant used. Leak detection equipment shall be set at a percentage of the LFL gas (25% maximum) is confirmed.

Leak detection fluids are also suitable for use with most refrigerants but the use of detergents containing chlorine shall be avoided as the chlorine may react with the refrigerant and corrode the copper pipe-work.

Examples of leak detection fluids are:

- Bubble method
- Fluorescent method agents

If a leak is suspected, all naked flames shall be removed/ extinguished.

If a refrigerant leak is found which requires brazing, all refrigerant shall be recovered from the system, or isolated (by means of shut-off valves) in a part of the system remote from the leak.

Refrigerant Removal and Evacuation

Ensure that the correct number of cylinders for holding the total system charge is available. All cylinders to be used are designated for the recovered refrigerant and labeled for that refrigerant (special cylinders for the recovery of refrigerant, for example). Cylinders shall be complete with pressure-relief valve and associated shut-off valves in good working order. Empty recovery cylinders are evacuated and, if possible, cooled before recovery occurs.

When breaking into the refrigerant circuit to make repairs – or for any other purpose – conventional procedures shall be used. However, for flammable refrigerants it is important that best practice be followed, since flammability is a consideration.

The following procedure shall be adhered to:

1. Safely remove refrigerant following local and national regulations.
2. Evacuate.
3. Purge the circuit with inert gas.
4. Evacuate (optional for A2L).
5. Continuously flush or purge with inert gas when using flame to open circuit.
6. Open the circuit.

Prior to refrigerant removal, open all appropriate valves, including solenoid and electronic expansion valves (EXVs). Use control settings, where available. When not available, manually open all electronically controlled valves using acceptable service procedures.

The recovery equipment shall be in good working order with instructions available. Equipment shall be suitable for the recovery of the flammable refrigerant. For specific handling concerns, contact the manufacturer. Ensure all hose connections are checked for tightness to avoid refrigerant leaks.

In addition, a set of calibrated weighing scales shall be available and in good working order.

The refrigerant shall be recovered into the correct recovery cylinders if venting is not allowed by local and national codes. Do not mix refrigerants in recovery unit and especially not in cylinders.

Refrigerant recovery unit should be purged with an inert gas after each use or before using with a different refrigerant Class – for example, A2L to A1.

If compressors or compressor oils are to be removed, ensure that they have been evacuated to an acceptable level to make certain that flammable refrigerant does not remain within the lubricant. The compressor body shall not be heated by an open flame or other ignition sources to accelerate this process. When oil is drained from a system, it shall be carried out safely.

The system shall be purged with oxygen-free nitrogen to render the appliance safe for flammable refrigerants. This process might need to be repeated several times.



A2L Information

Compressed air or oxygen shall not be used for purging refrigerant systems.

The system shall be vented down to atmospheric pressure to enable work to take place.

The outlet for the vacuum pump shall not be close to any potential ignition sources, and ventilation shall be available.

Refrigerant Charging

In addition to conventional charging procedures, the following requirements shall be followed.

- Ensure that contamination of different refrigerants does not occur when using charging equipment.
- Hoses or lines shall be as short as possible to minimize the amount of refrigerant contained in them.
- Cylinders shall be kept in an appropriate position according to the instructions.
- Ensure that the refrigerating system is earthed prior to charging the system with refrigerant.
- Label the system when charging is complete (if not already).
- Extreme care shall be taken not to overfill the refrigerating system.

Prior to recharging the system, it shall be pressure-tested with the appropriate purging gas. The system shall be leak-tested on completion of charging but prior to commissioning. A follow up leak test shall be carried out prior to leaving the site.

Prior to refrigerant charging, open all appropriate valves, including solenoid and electronic expansion valves (EXVs). Use control settings, where available. When not available, manually open all electronically controlled valves using acceptable service procedures.

Verify the equipment refrigerant charge is in accordance with the room area limitation as described in Minimum Room Area Limits section.

Decommissioning

Before carrying out the decommissioning procedure, it is essential that the trained service personnel is completely familiar with the equipment and all its details. It is recommended good practice that all refrigerants are recovered safely. Prior to the task being carried out, an oil and refrigerant sample shall be taken in case analysis is required prior to re-use of recovered refrigerant. It is essential that electrical power is available before the task is commenced.

1. Become familiar with the equipment and its operation.
2. Isolate system electrically.
3. Before attempting the procedure, ensure that:
 - a. Mechanical handling equipment is available, if required, for handling refrigerant cylinders.
 - b. All personal protective equipment is available and being used correctly.

- c. The recovery process is supervised at all times by a competent person.

- d. Recovery equipment and cylinders conform to the appropriate standards.

4. Pump down refrigerant system, if possible.
5. If a vacuum is not possible, make a manifold so that refrigerant can be removed from various parts of the system.
6. Make sure that cylinder is situated on the scales before recovery takes place.
7. Start the recovery machine and operate in accordance with instructions.
8. Do not overfill cylinders (no more than 80% volume liquid charge).
9. Do not exceed the maximum working pressure of the cylinder, even temporarily.
10. When the cylinders have been filled correctly and the process completed, make sure that the cylinders and the equipment are removed from site promptly and all isolation valves on the equipment are closed off.
11. Recovered refrigerant shall not be charged into another refrigerating system unless it has been cleaned and checked.
12. When equipment has been decommissioned, attach a signed and dated label stating it has been decommissioned and emptied of refrigerant.
13. Ensure that there are labels on the equipment stating it contains flammable refrigerant.

A2L Application Considerations

This product is listed to UL standard 60335-2-40, Household and Similar Electrical Appliances – Safety – Part 2-40: Particular Requirements for Electrical Heat Pumps, Air-Conditioners and Dehumidifiers, which defines safe design and use strategies for equipment using A2L refrigerants. This standard limits the refrigerant concentration in a space in the event of a refrigerant leak. To meet the requirements, the UL standard defines minimum room area, refrigerant charge limit, minimum circulation airflow and/or ventilation airflow requirements, and limits the use of ignition sources in spaces. The standard may require a unit refrigerant leak detection system.

For equipment with R-454B and charge amounts less than or equal to 3.91 lbs per circuit, this UL standard does not prescribe a room area limit and does not require a refrigerant leak detection system or any circulation airflow or ventilation airflow mitigation strategies.

Depending on the application, a specific requirement of ANSI/ASHRAE Standard 15, Safety Standard for Refrigeration Systems, could be more stringent than UL 60335-2-40 requirements. See *Refrigeration Systems and Machinery Rooms Application Considerations for Compliance with ASHRAE® Standard 15-2022 Application*

Engineering Manual (APP-APM001*-EN) for more information.

Ignition Sources in Unit

This UL-listed unit does not contain any ignition sources. All potential ignition sources were evaluated during product UL listing.

Minimum Room Area Limits (Refrigerant charge greater than 3.91 lb per circuit)

Equipment with R-454B charge amounts greater than 3.91 lb per circuit may require additional circulation or ventilation airflow mitigation strategies.

When additional ventilation airflow is required, if the room area A is below the adjusted A_{min} threshold, additional ventilation is required to remove refrigerant in the event of a leak. Refer to UL 60335-2-40 Clause GG.8 and ANSI VASHRAE Standard 15 Section 7 for natural and mechanical ventilation requirements. See equipment nameplate and table below for minimum room area.

Split systems minimum room area requirements need to be determined after final field charging. Use the following figures and the largest final circuit charge to determine the systems A_{min} value. Record the final charge value on the label provided on the unit.

Figure 1. Charge vs min room area (IP)

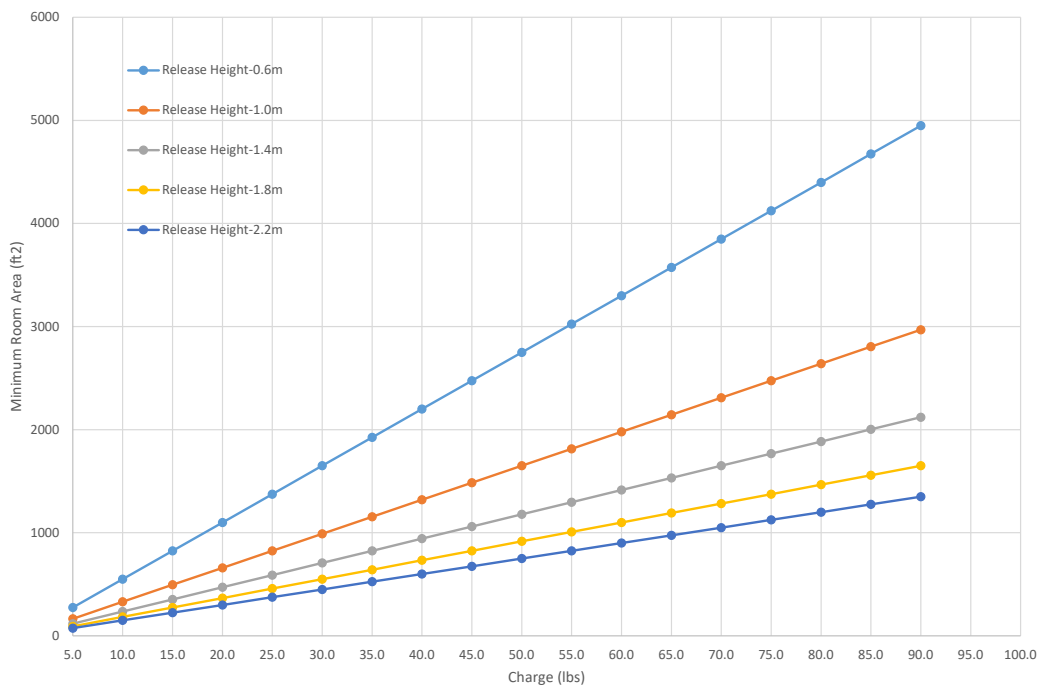
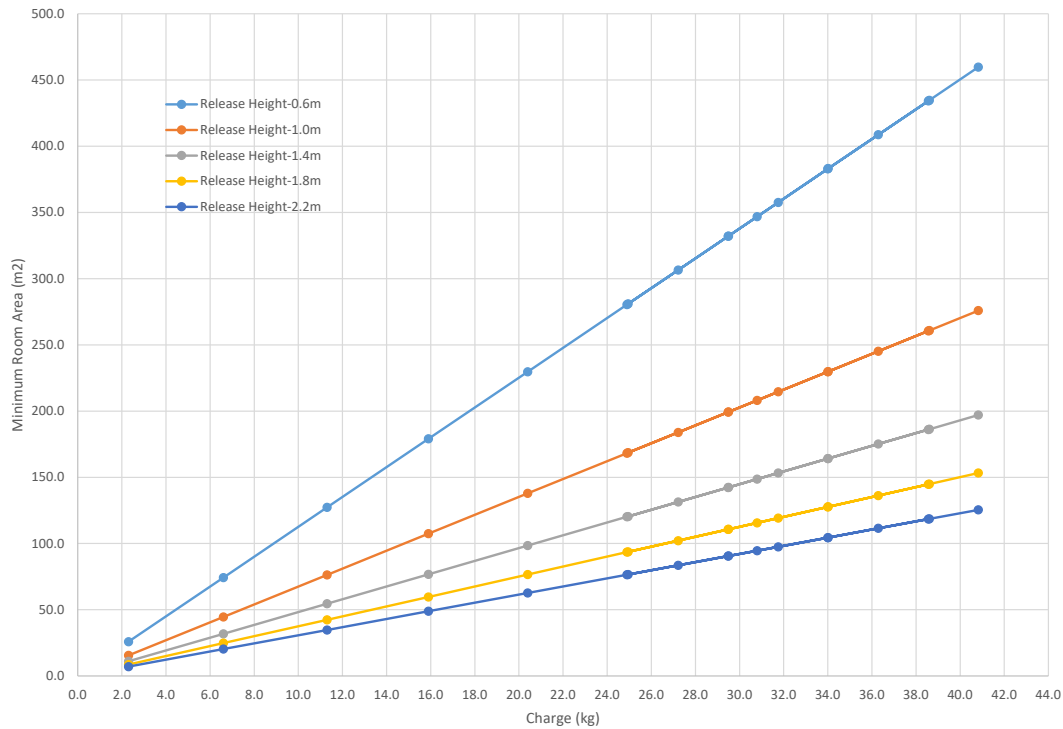

Figure 2. Charge vs min room area (SI)

Release height is the vertical distance from the floor to the lowest point in a space refrigerant would leak from first. The minimum value is 0.6 m from the floor.

Determining Room Area (A)

The room area (A) is the room area enclosed by the projection to the floor of the walls, partitions, and doors of the space that the equipment serves.

Rooms connected by drop ceilings only are not considered a single room.

Rooms on the same floor of the building, and connected by an open passageway, can be considered part of the same room if the passageway is a permanent opening, extends to the floor and is intended for people to walk through.

Adjacent rooms on the same floor of the building and connected by permanent openings in the walls and/or doors between rooms (including gaps between the wall and the floor), can be considered part of the same room if the openings meet the following criteria.

- The opening is permanent and cannot be closed.
- Openings extending to the floor, such as door gaps, need to be at least 20mm above the floor covering surface.
- Natural ventilations opening areas must meet the requirements of ANSIASHRAE Standard 15-2022, Section 7.2.3.2.

Rooms that are connected by a mechanical ventilation system can be considered a single room area if the

mechanical ventilation system meets the requirements of ANSIASHRAE Standard 15-2022, Section 7.6.4.

Field Piping Installation and Charging

When refrigerant piping is routed indoors, protect from physical damage in operation or service, and verify installation complies with national and local codes. All joints must be accessible for inspection prior to being covered.

Follow the Refrigerant Charging procedure. Prior to refrigerant charging, check field-made indoor joints for leaks using an instrument with a sensitivity of 5 grams per year refrigerant. Pressurize the system to 25% of the maximum allowable pressure. Verify no leaks are detected.

Dimensions and Weights

Unit Clearances

The figure below illustrates the minimum operating and service clearances for either a single, multiple, or pit application. These clearances are the minimum distances necessary to assure adequate serviceability, cataloged unit capacity, and peak operating efficiency.

Important: Providing less than the recommended clearances could result in condenser coil starvation or recirculation of hot condenser air.

Locate the unit as close to the applicable system support equipment as possible to minimize refrigerant piping lengths.

Allow adequate clearance for water and refrigerant piping connections, space to perform service procedures, i.e. read gauges, thermometers, and operate water system valves.

Notes:

- EVP braze plate chiller installation must also allow adequate clearance as described above.
- EVP chiller is intended for indoor application. If a sub-freezing location is required, contact Trane for installation precautions required to prevent damage.

Figure 3. Unit clearances

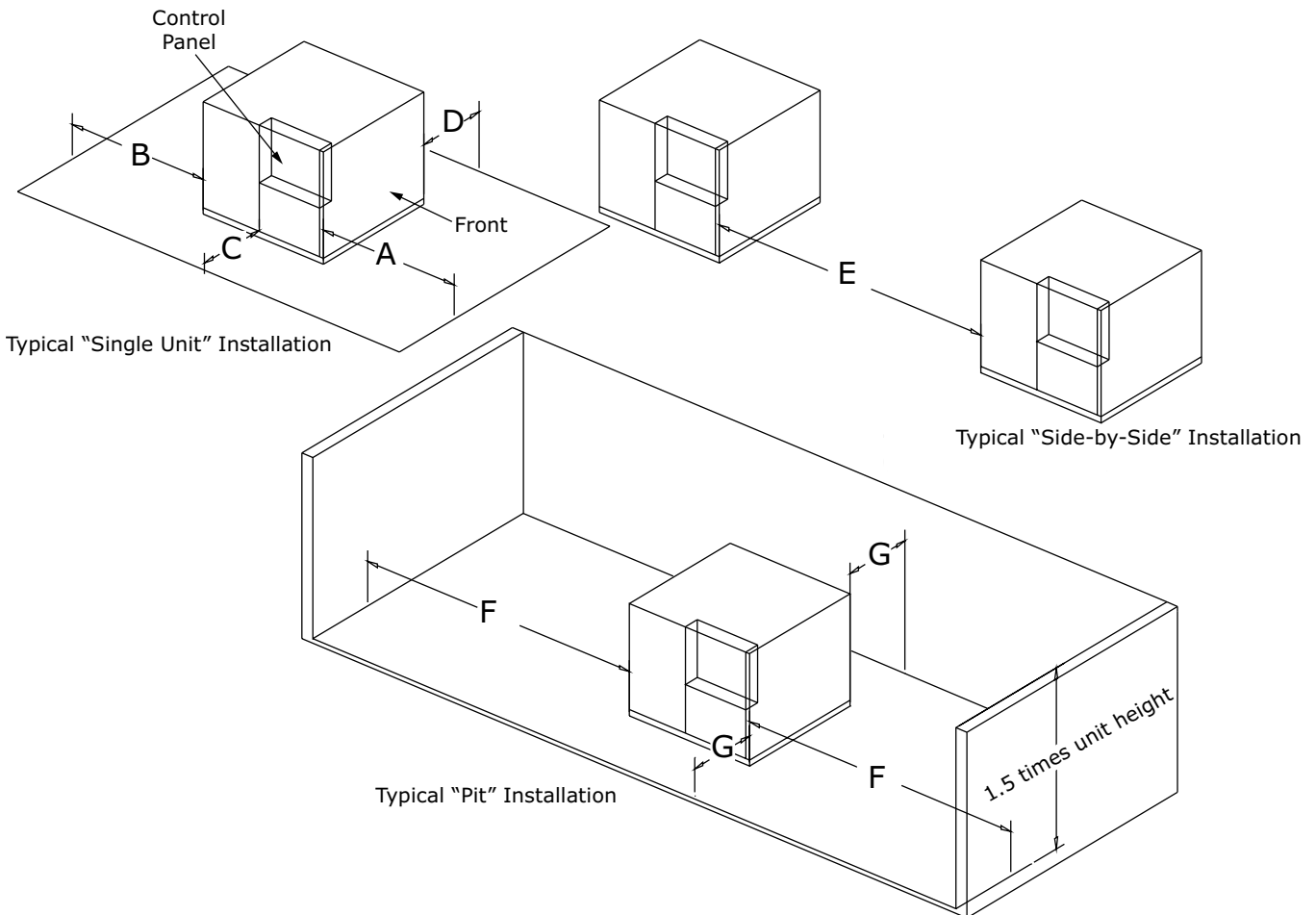



Dimensions and Weights

Table 3. Unit clearances

Dimension	Location	Clearance (in)	
		20 to 60 tons	80 to 120 tons
A	Front	72	96
B	Back	72	96
C	Left (control panel side)	48	48
D	Right	42	48
E	Distance between units (side-by-side)	192	192
F	Pit installation - front and back	192	192
G	Pit installation - sides	48	48

Unit Dimensions

Figure 4. Air-cooled condensing unit — 20 ton

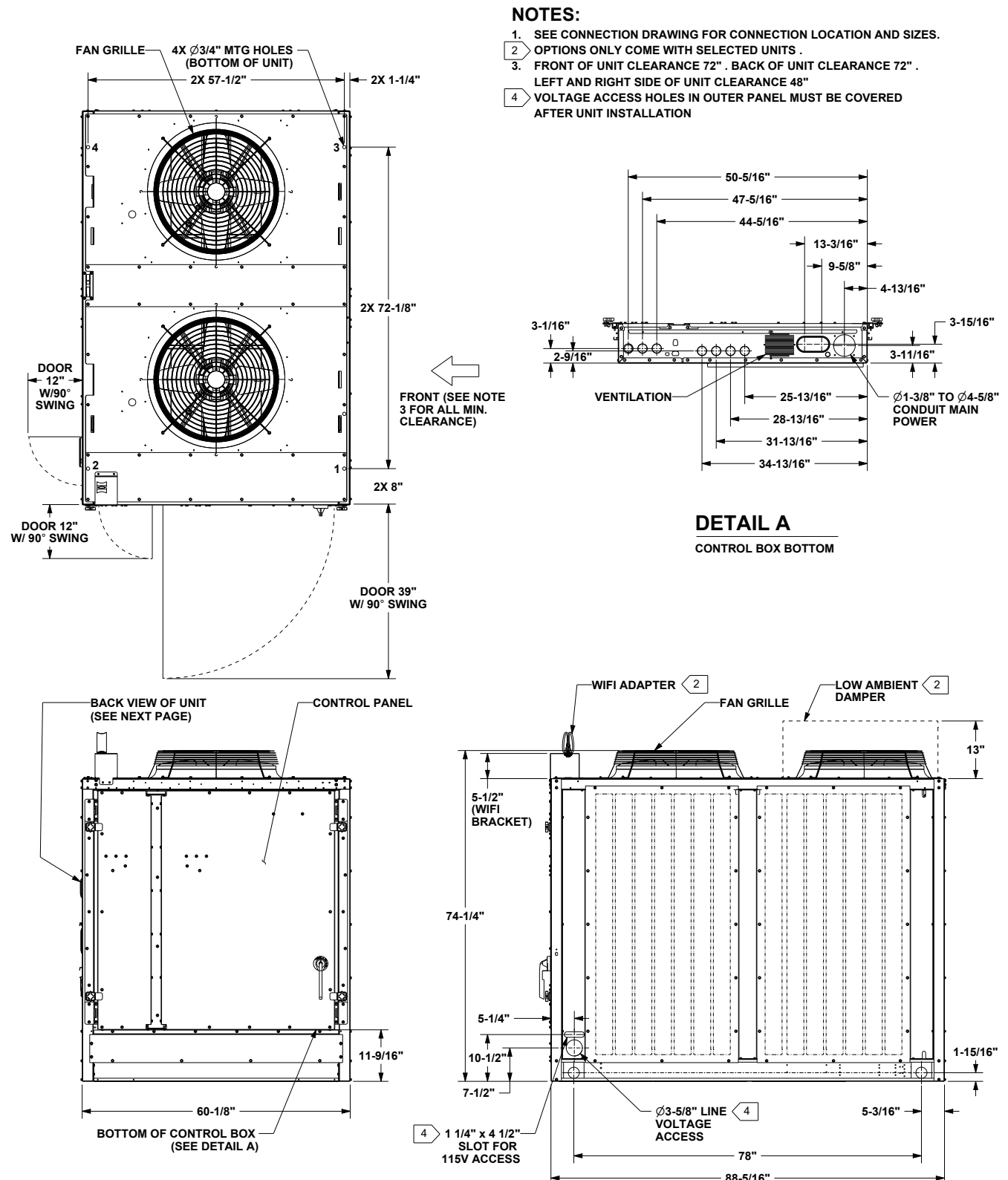

Dimensions and Weights

Figure 5. Air-cooled condensing unit connections — 20 ton (R-410A)

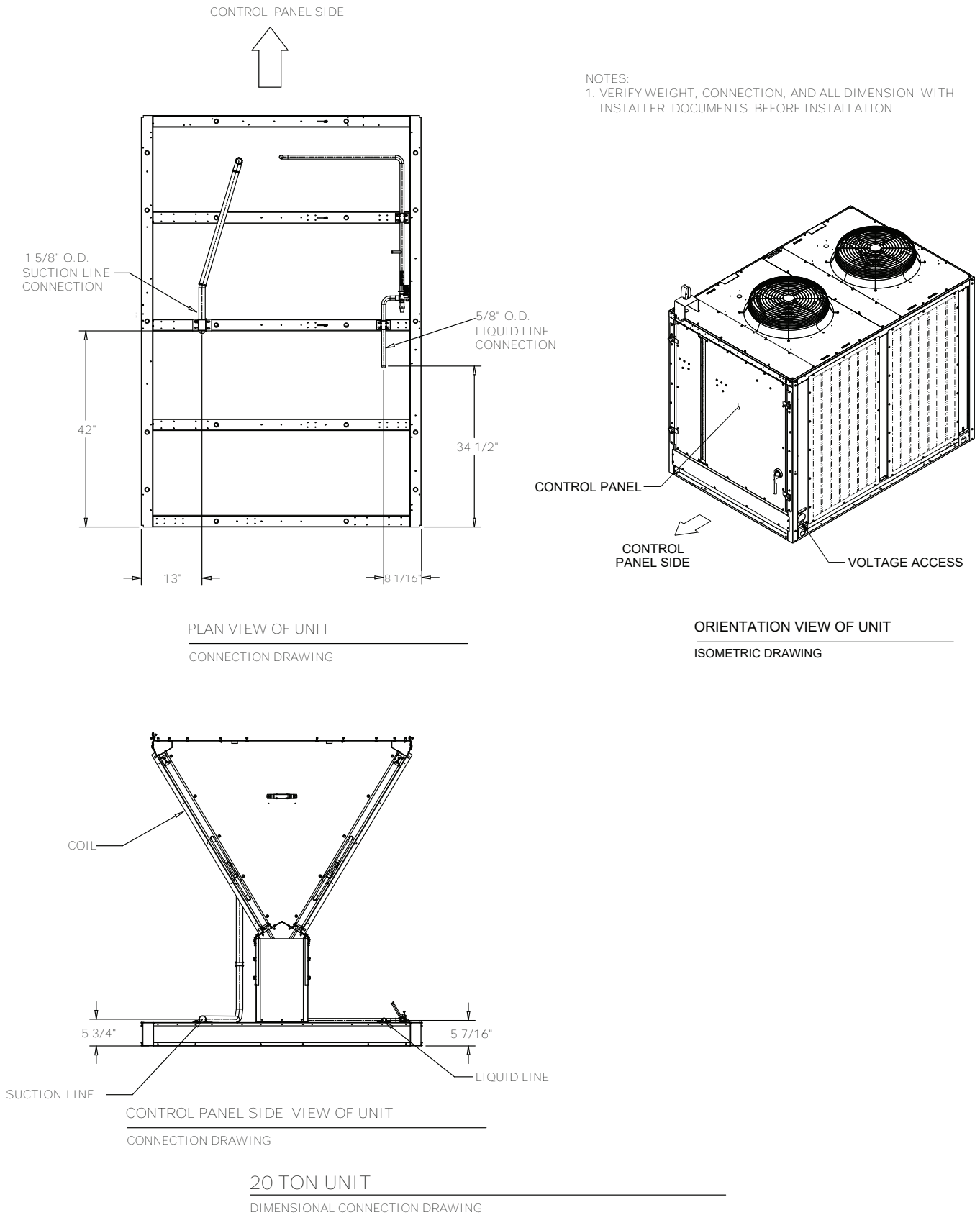
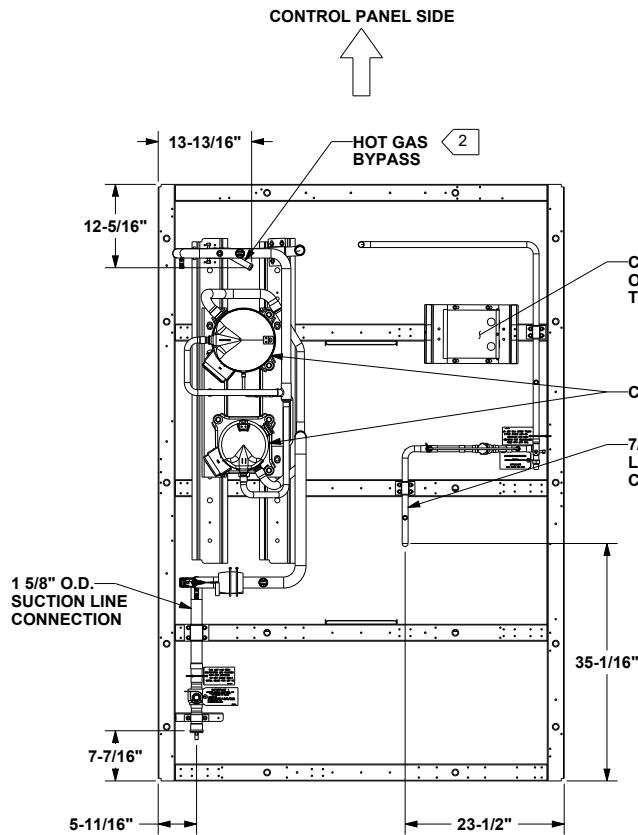

Figure 6. Air-cooled condensing unit connections — 20 ton (R-454B)



PLAN VIEW OF UNIT
CONNECTION DRAWING

NOTES:

1. VERIFY WEIGHT, CONNECTION, AND ALL DIMENSIONS WITH INSTALLER DOCUMENTS BEFORE INSTALLATION.
2. OPTIONS ONLY COME WITH SELECTED UNITS.
3. TD7 CONTROL ONLY COMES WITH SELECTED UNITS.

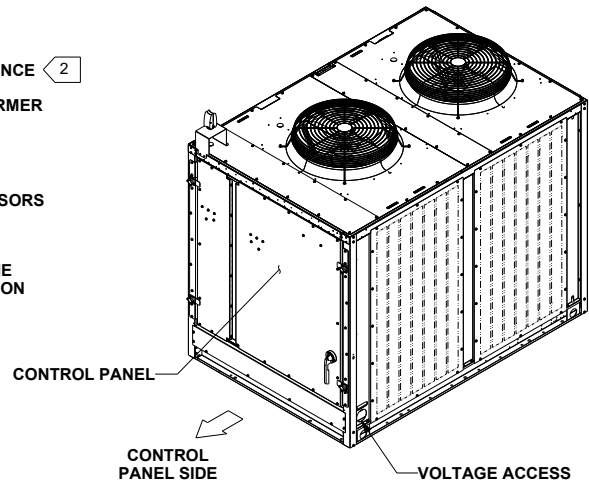

ORIENTATION VIEW OF UNIT
ISOMETRIC DRAWING

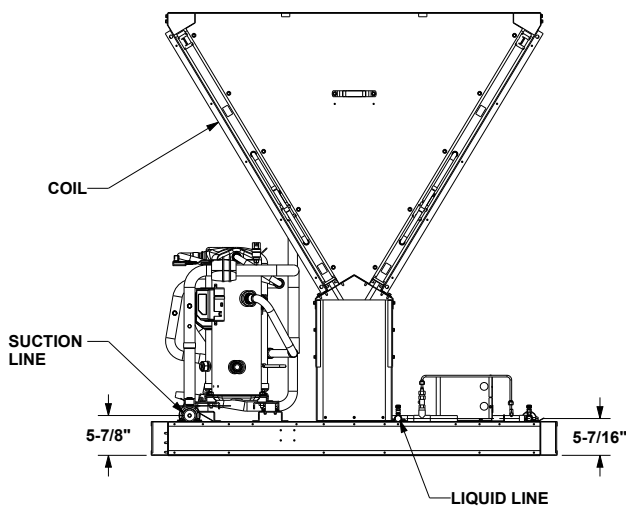

VIEW OPPOSITE OF CONTROL PANEL
CONNECTION DRAWING

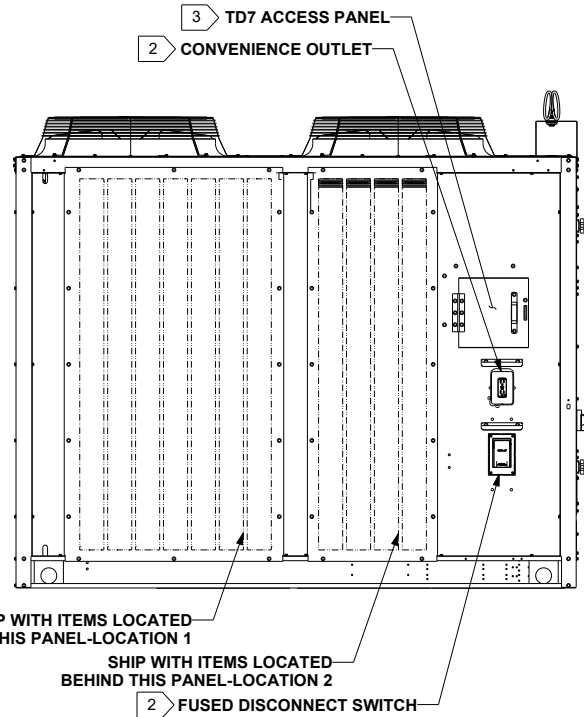

BACK VIEW OF UNIT

20 TON UNIT

DIMENSION CONNECTION DRAWING

Dimensions and Weights

Figure 7. Air-cooled condensing unit — 25 and 30 tons

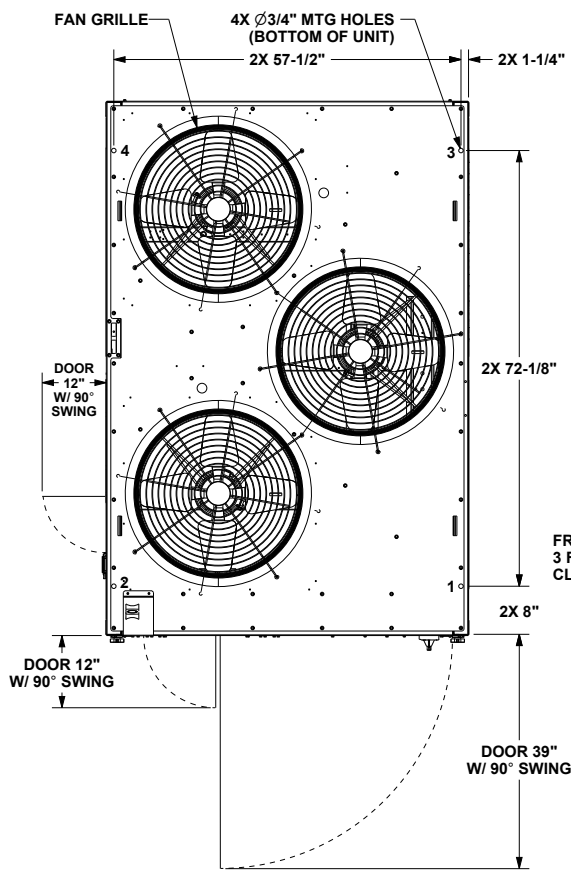

NOTES:

1. SEE CONNECTION DRAWING FOR CONNECTION LOCATION AND SIZES.
2. OPTIONS ONLY COME WITH SELECTED UNITS.
3. FRONT OF 25T AND 30T UNIT CLEARANCE 72". BACK OF UNIT CLEARANCE 72". LEFT AND RIGHT SIDE OF 25T AND 30T UNIT CLEARANCE 48".
4. VOLTAGE ACCESS HOLES IN OUTER PANEL MUST BE COVERED AFTER UNIT INSTALLATION.

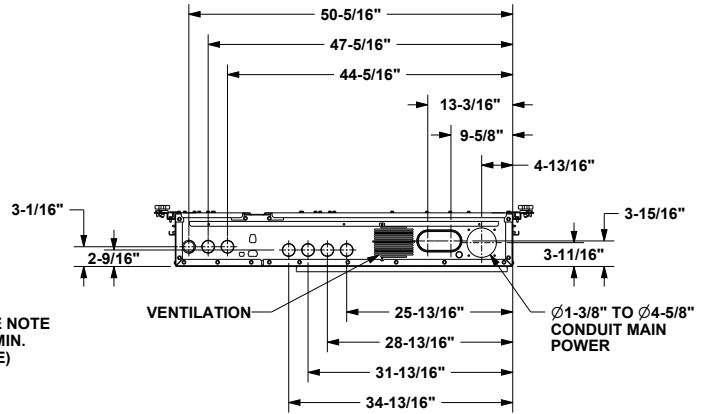

DETAIL A

CONTROL BOX BOTTOM

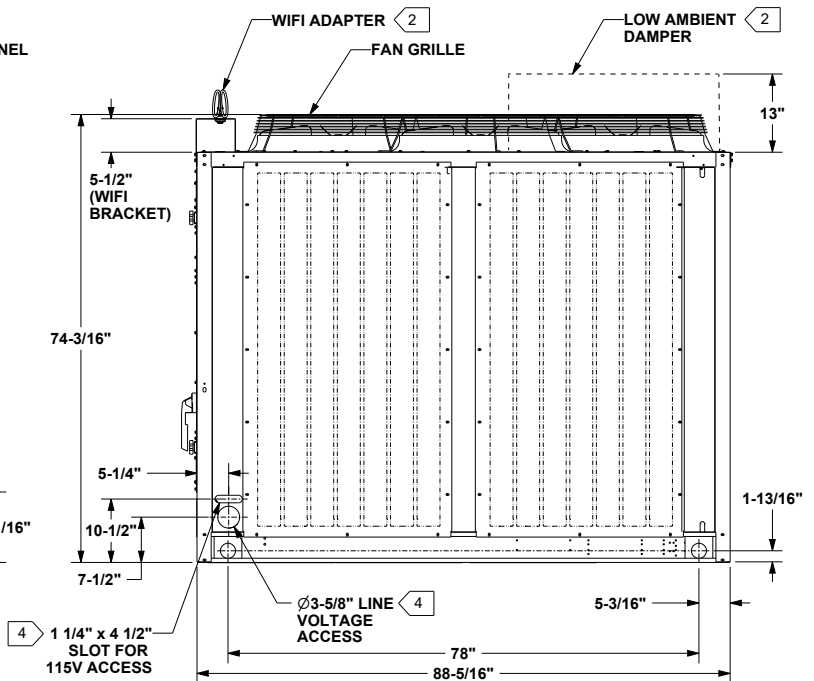
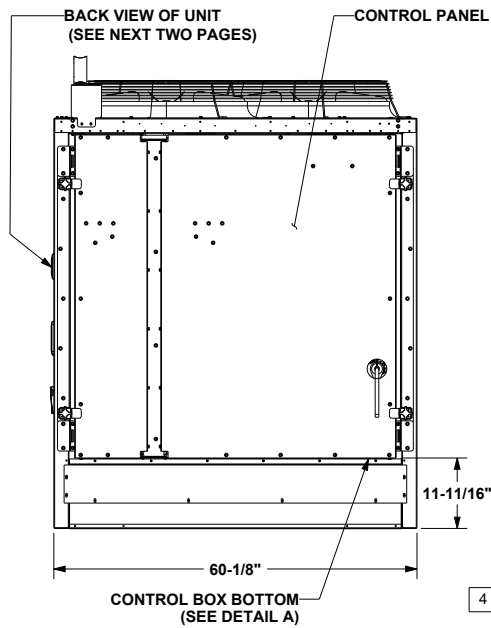
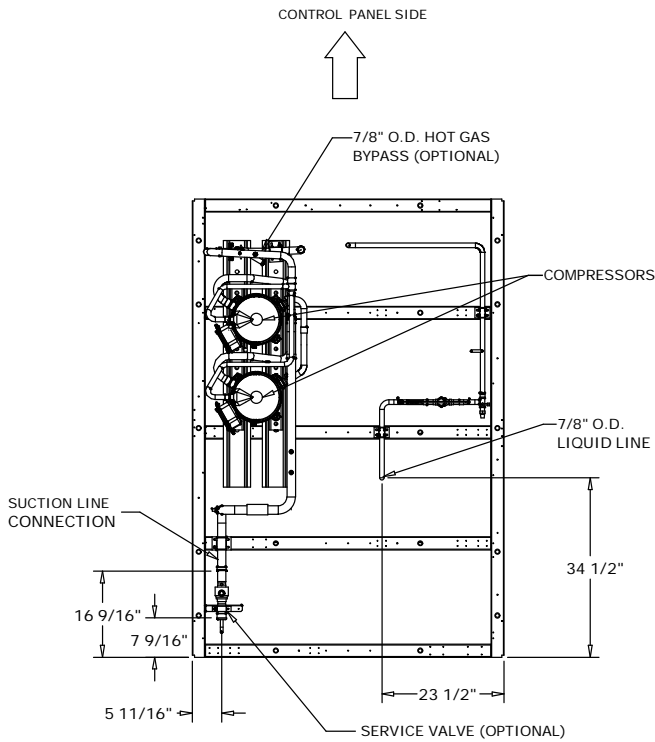
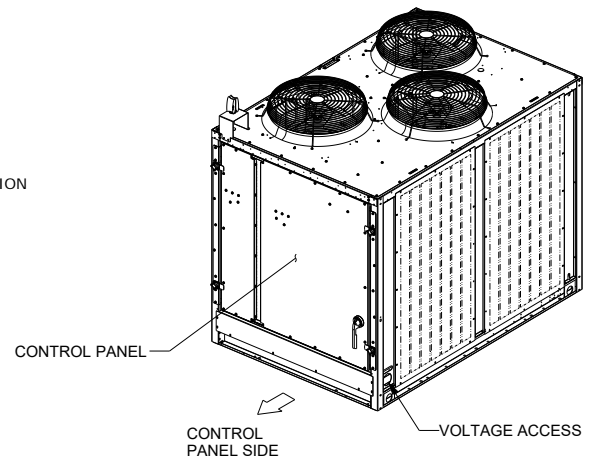

Figure 8. Air-cooled condensing unit connections — 25 and 30 tons (R-410A)



PLAN VIEW OF UNIT
CONNECTION DRAWING



ORIENTATION VIEW OF UNIT
ISOMETRIC DRAWING

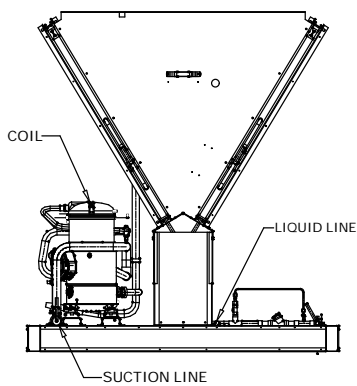

CONTROL PANEL SIDE VIEW OF UNIT
CONNECTION DRAWING

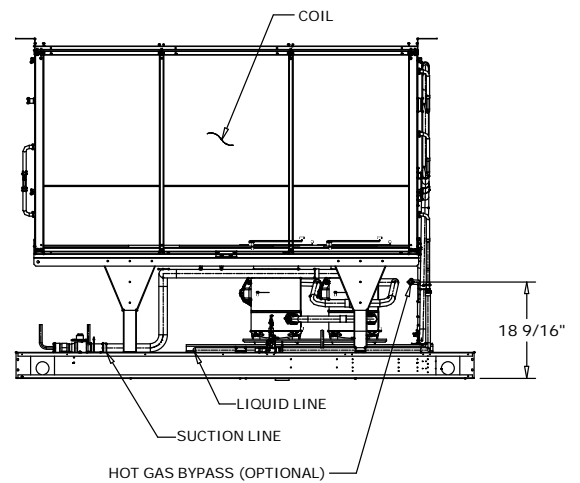

BACK VIEW OF UNIT
CONNECTION DRAWING



Dimensions and Weights

Figure 9. Air-cooled condensing unit connections — 25 tons (R-454B)

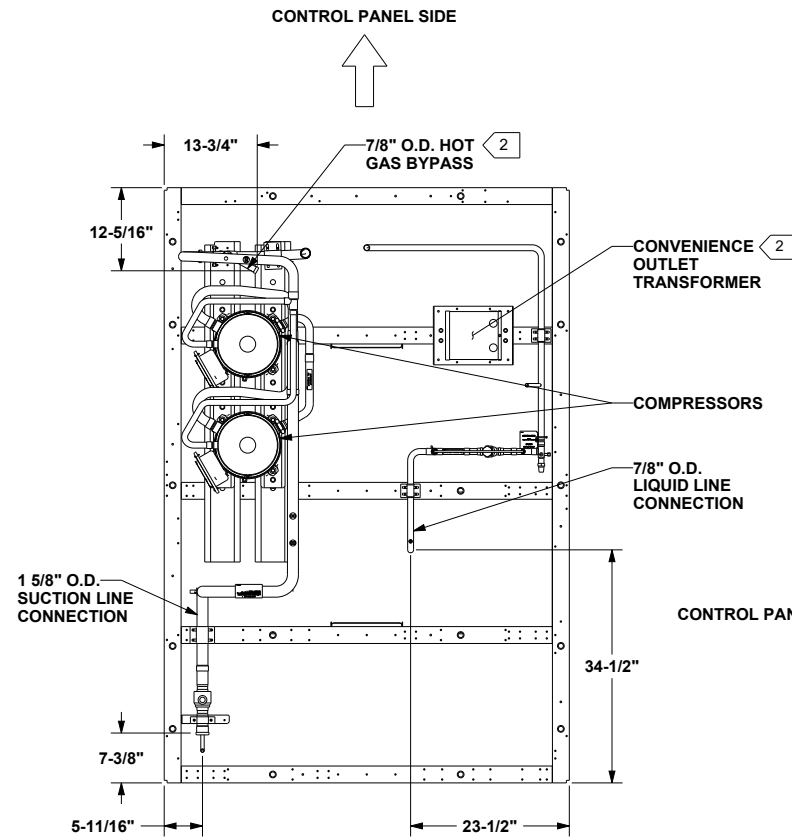

PLAN VIEW OF UNIT
CONNECTION DRAWING

- NOTES:**
1. VERIFY WEIGHT, CONNECTION, AND ALL DIMENSIONS WITH INSTALLER DOCUMENTS BEFORE INSTALLATION.
 2. OPTIONS ONLY COME WITH SELECTED UNITS.
 3. TD7 CONTROL ONLY COMES WITH SELECTED UNITS.

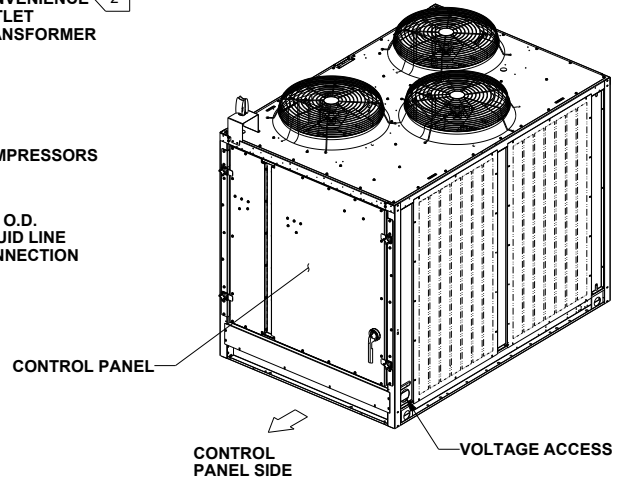

ORIENTATION VIEW OF UNIT
ISOMETRIC DRAWING

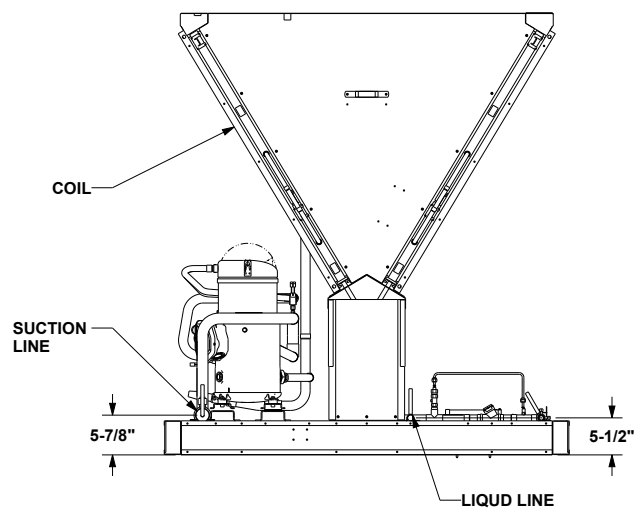

VIEW OPPOSITE OF CONTROL PANEL
CONNECTION DRAWING

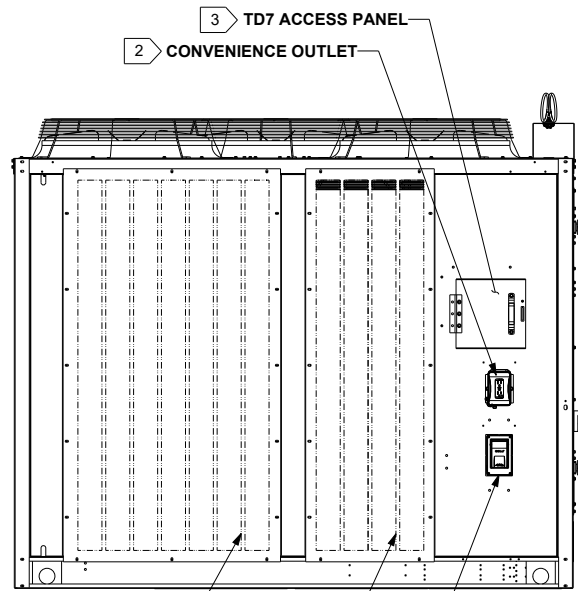

BACK VIEW OF UNIT

25 TON UNIT
DIMENSION CONNECTION DRAWING

Figure 10. Air-cooled condensing unit connections — 30 tons (R-454B)

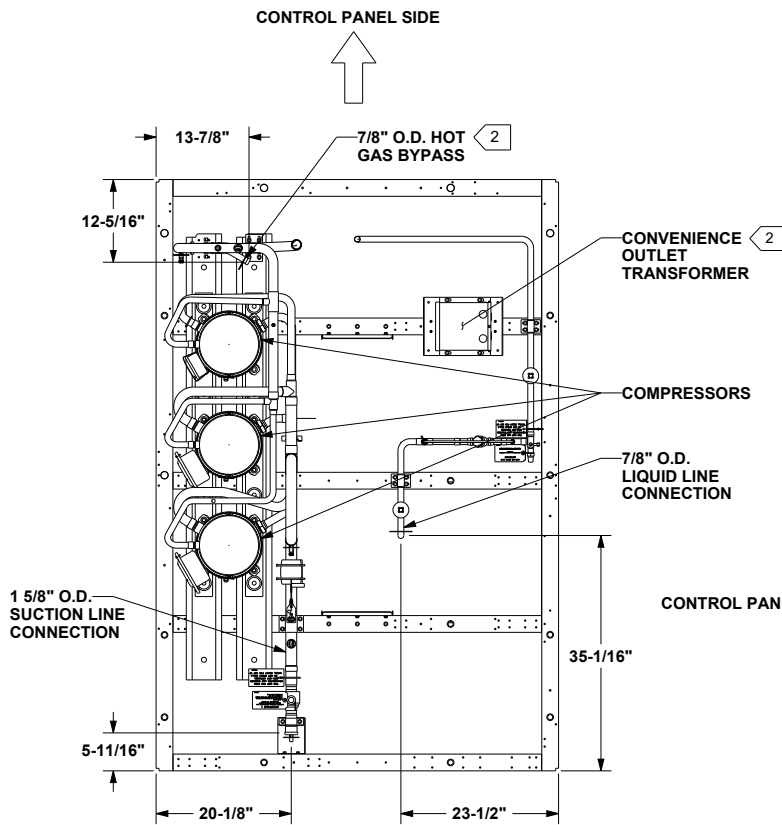

PLAN VIEW OF UNIT
CONNECTION DRAWING

NOTES:

1. VERIFY WEIGHT, CONNECTION, AND ALL DIMENSIONS WITH INSTALLER DOCUMENTS BEFORE INSTALLATION.
2. OPTIONS ONLY COME WITH SELECTED UNITS.
3. TD7 CONTROL ONLY COMES WITH SELECTED UNITS.

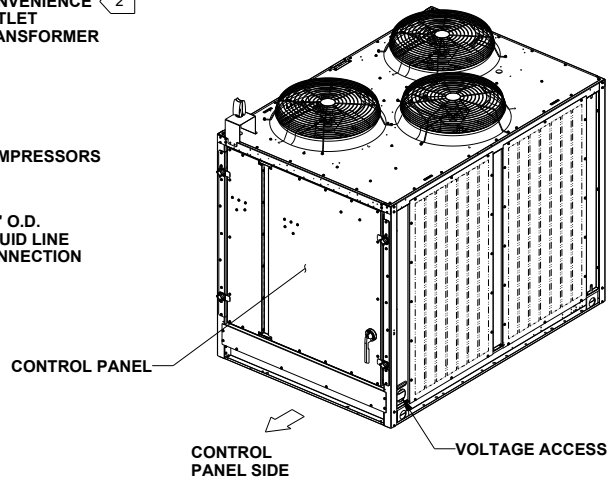

ORIENTATION VIEW OF UNIT
ISOMETRIC DRAWING

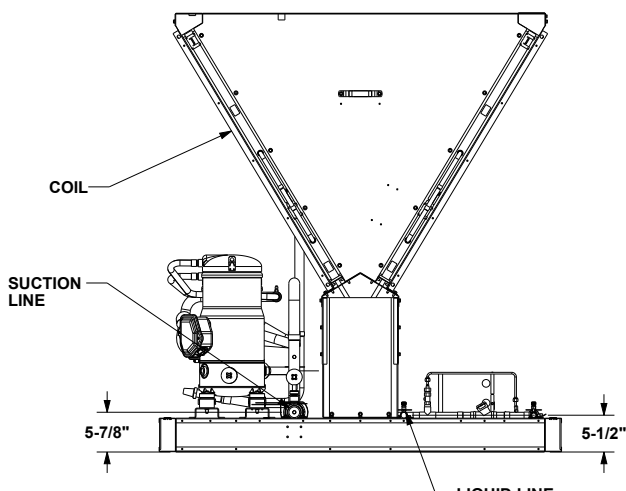

VIEW OPPOSITE OF CONTROL PANEL
CONNECTION DRAWING

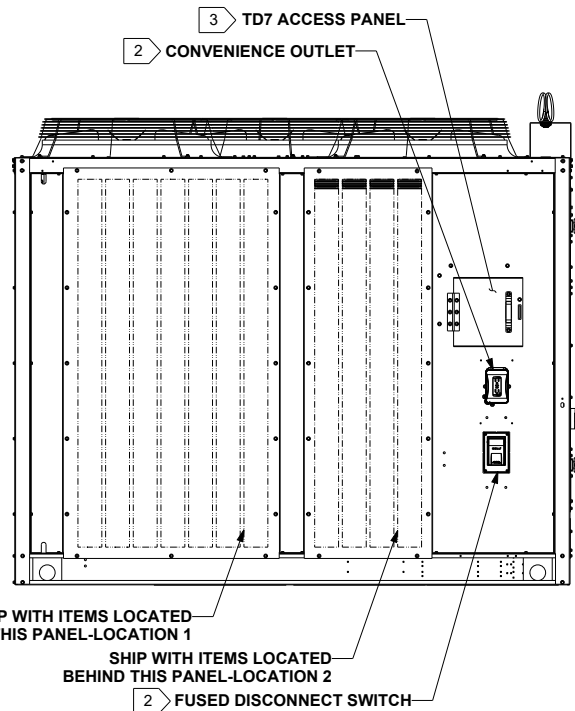

BACK VIEW OF UNIT

30 TON UNIT
DIMENSION CONNECTION DRAWING



Dimensions and Weights

Figure 11. Air-cooled condensing unit — 40 ton

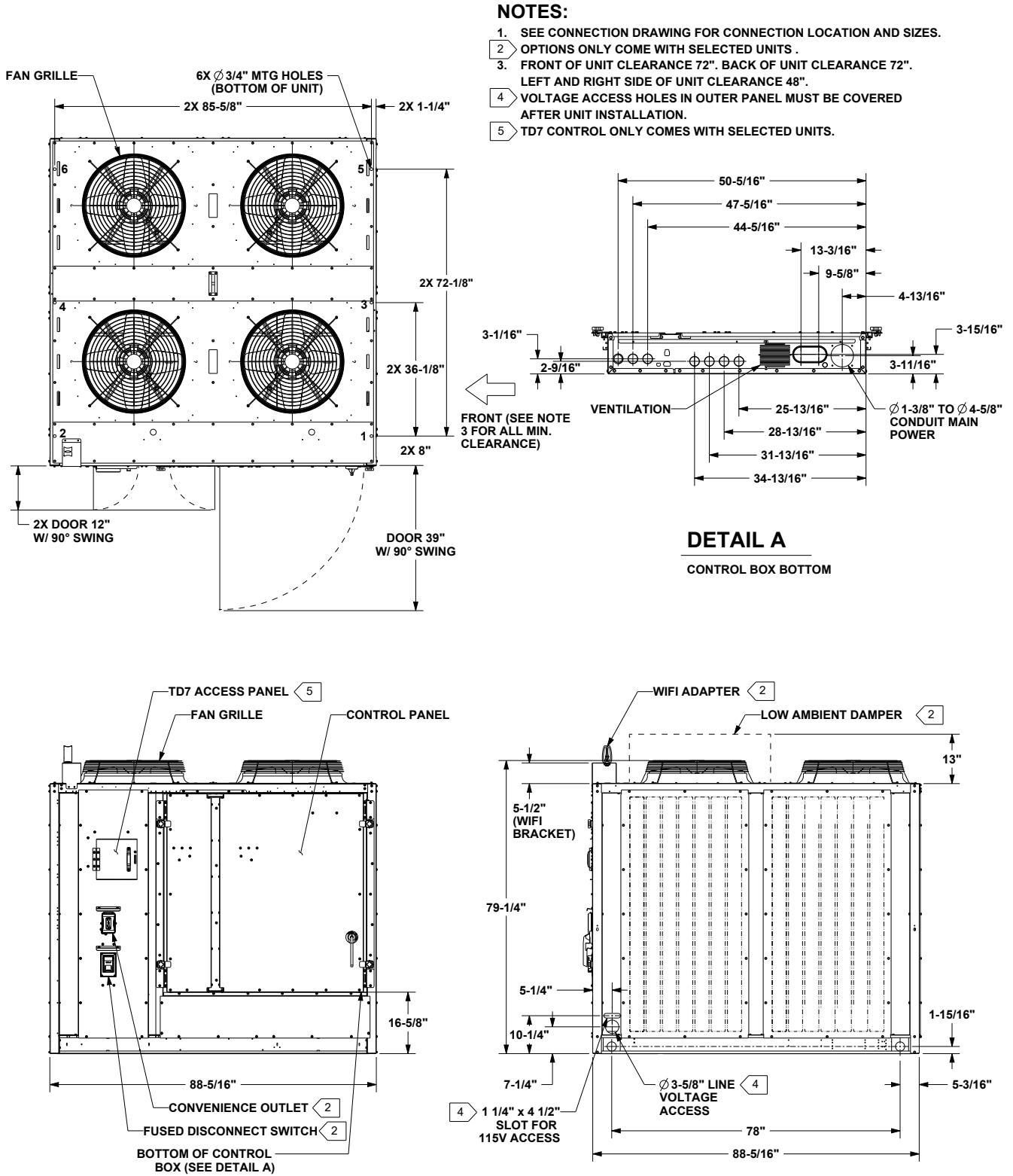
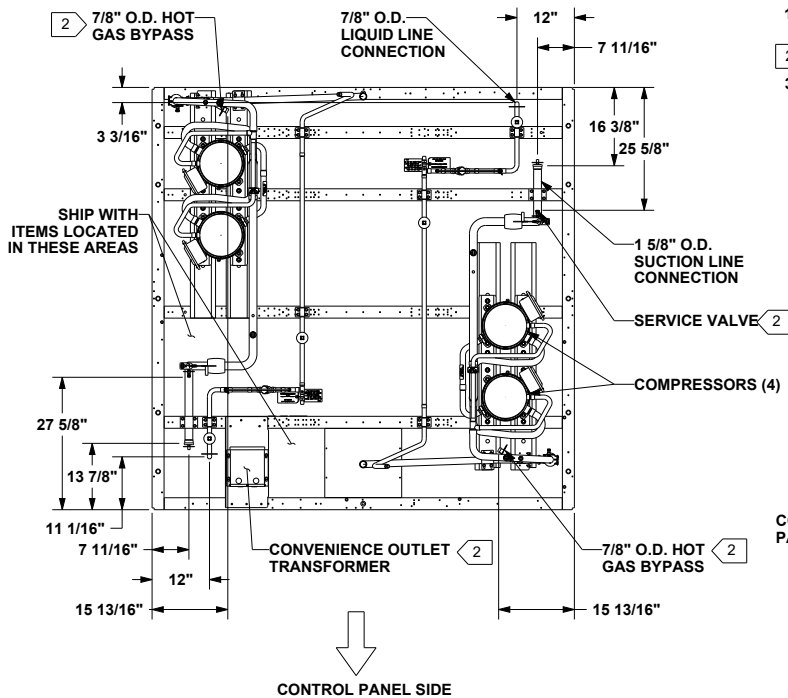

Figure 12. Air-cooled condensing unit connections — 40 ton



PLAN VIEW OF UNIT
CONNECTION DRAWING

NOTES:

1. VERIFY WEIGHT, CONNECTION, AND ALL DIMENSIONS WITH INSTALLER DOCUMENTS BEFORE INSTALLATION.
2. OPTIONS ONLY COME WITH SELECTED UNITS.
3. DUAL CIRCUIT UNIT REQUIRES TWO SEPARATE LINE SETS (TWO SUCTION LINES AND TWO LIQUID LINES).

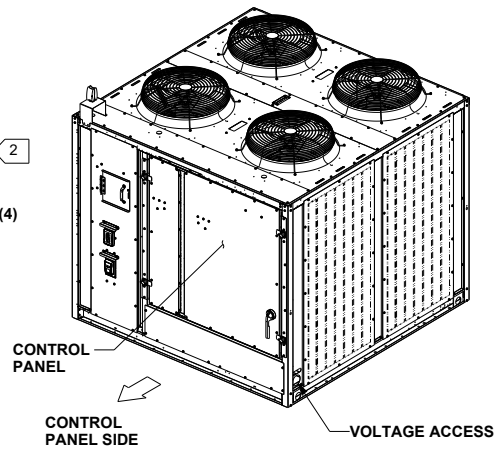

ORIENTATION VIEW OF UNIT
ISOMETRIC DRAWING

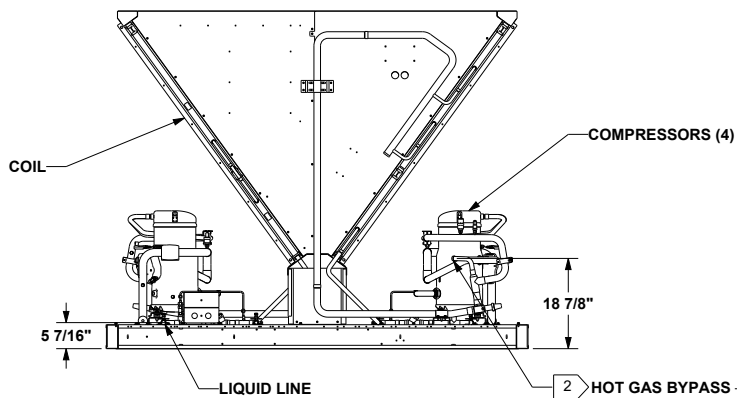

CONTROL PANEL SIDE VIEW OF UNIT
CONNECTION DRAWING

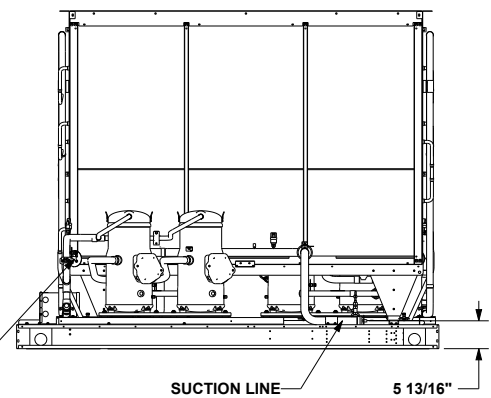

FRONT OF UNIT
CONNECTION DRAWING

40 TON UNIT
DIMENSION CONNECTION DRAWING



Dimensions and Weights

Figure 13. Air-cooled condensing unit — 50 ton

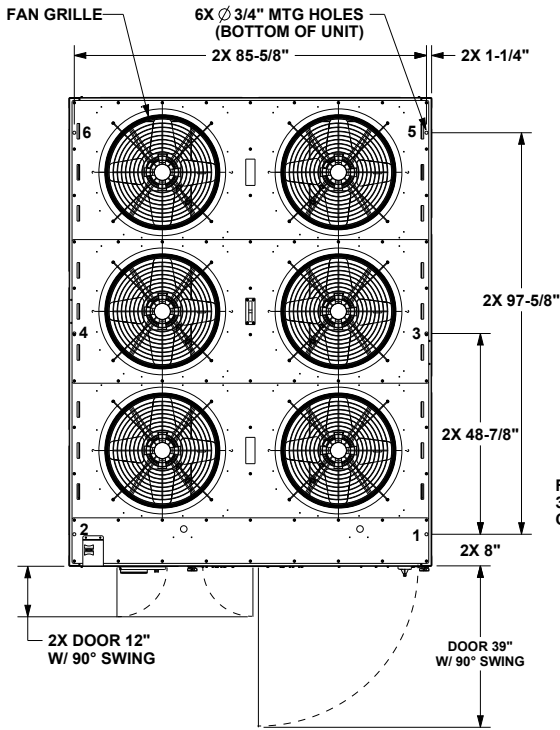

NOTES:

1. SEE CONNECTION DRAWING FOR CONNECTION LOCATION AND SIZES.
2. OPTIONS ONLY COME WITH SELECTED UNITS.
3. FRONT OF UNIT CLEARANCE 72". BACK OF UNIT CLEARANCE 72". LEFT AND RIGHT SIDE OF UNIT CLEARANCE 48".
4. VOLTAGE ACCESS HOLES IN OUTER PANEL MUST BE COVERED AFTER UNIT INSTALLATION.
5. TD7 CONTROL ONLY COMES WITH SELECTED UNITS.

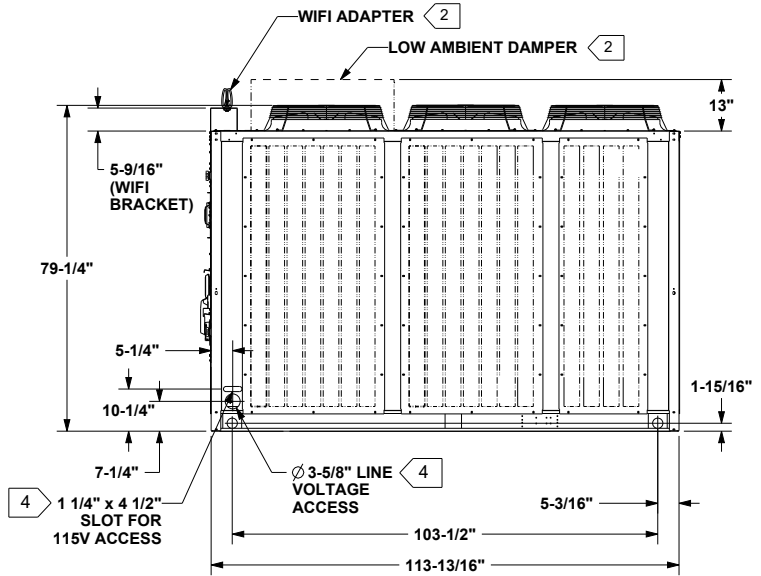
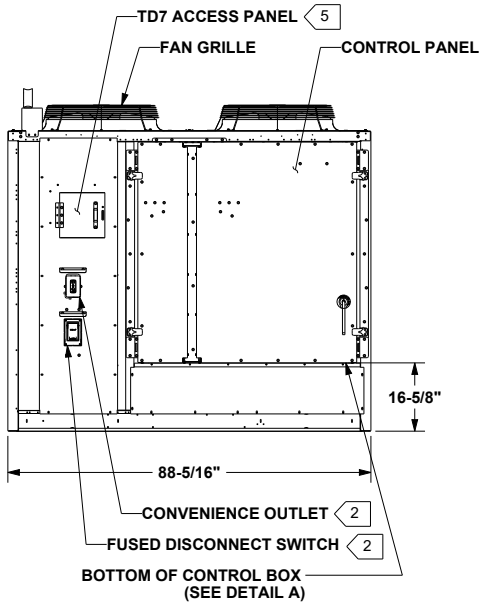
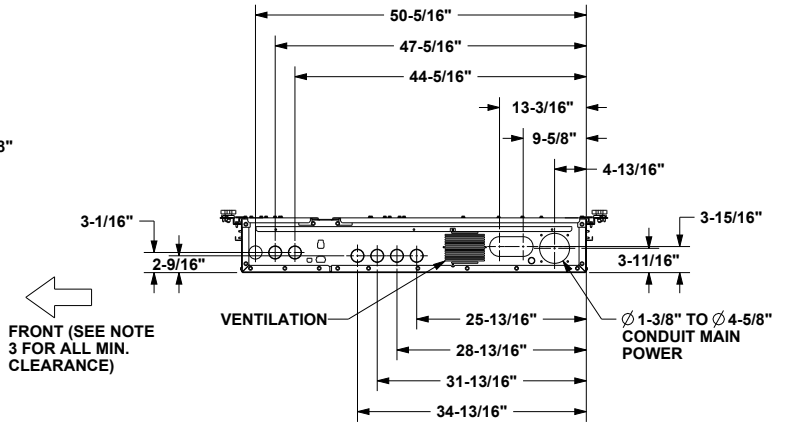
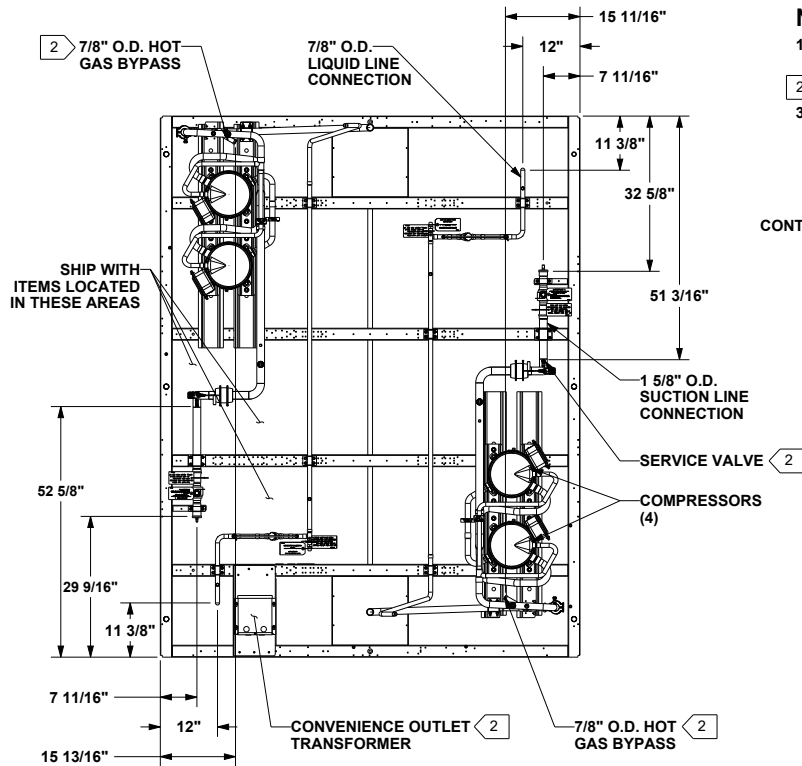
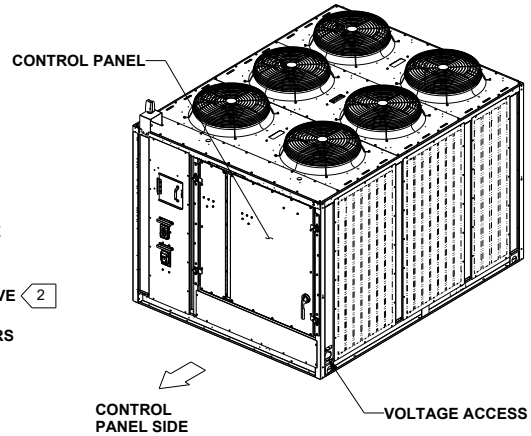

Figure 14. Air-cooled condensing unit connections — 50 ton



NOTES:

1. VERIFY WEIGHT, CONNECTION, AND ALL DIMENSIONS WITH INSTALLER DOCUMENTS BEFORE INSTALLATION.
2. OPTIONS ONLY COME WITH SELECTED UNITS.
3. DUAL CIRCUIT UNIT REQUIRES TWO SEPARATE LINE SETS (TWO SUCTION LINES AND TWO LIQUID LINES).



ORIENTATION VIEW OF UNIT
ISOMETRIC DRAWING

CONTROL PANEL SIDE

PLAN VIEW OF UNIT
CONNECTION DRAWING

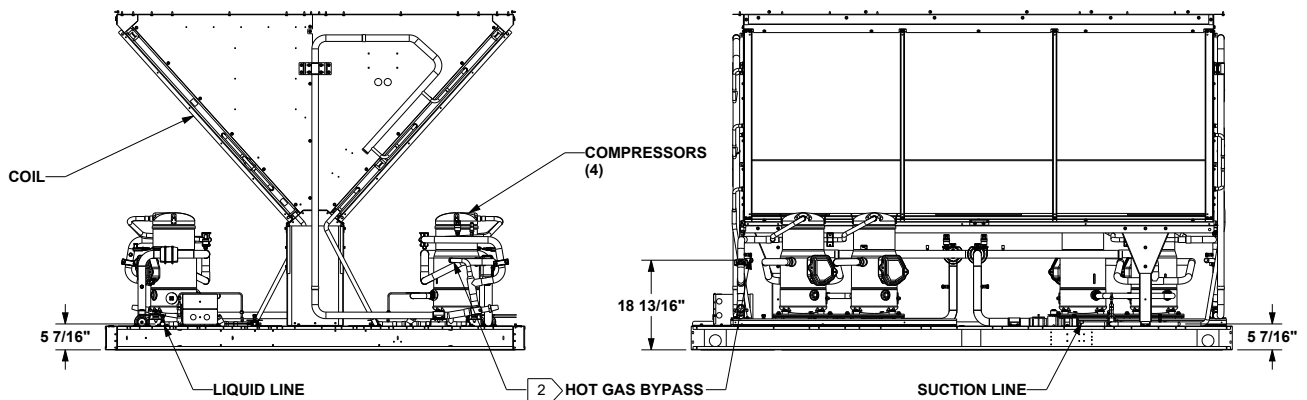

CONTROL PANEL SIDE VIEW OF UNIT
CONNECTION DRAWING

FRONT VIEW OF UNIT
CONNECTION DRAWING

50 TON UNIT
DIMENSION CONNECTION DRAWING



Dimensions and Weights

Figure 15. Air-cooled condensing unit — 60 ton

NOTES:

1. SEE CONNECTION DRAWING FOR CONNECTION LOCATION AND SIZES.
2. OPTIONS ONLY COME WITH SELECTED UNITS.
3. FRONT OF UNIT CLEARANCE 72". BACK OF UNIT CLEARANCE 72". LEFT AND RIGHT SIDE OF UNIT CLEARANCE 48".
4. VOLTAGE ACCESS HOLES IN OUTER PANEL MUST BE COVERED AFTER UNIT INSTALLATION.
5. TD7 CONTROL ONLY COMES WITH SELECTED UNITS.

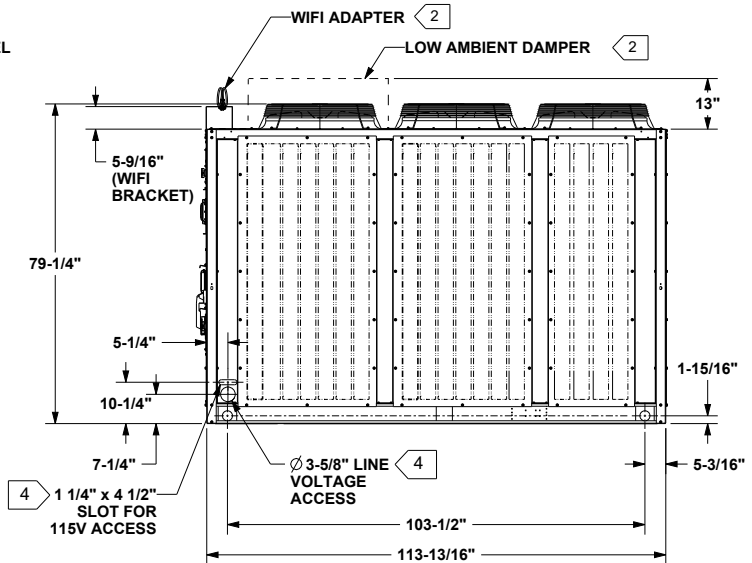
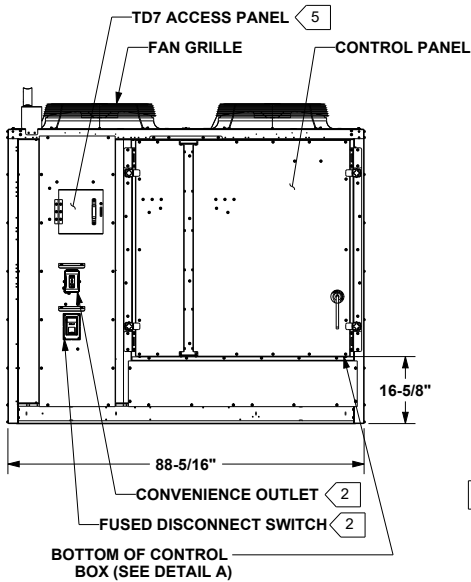
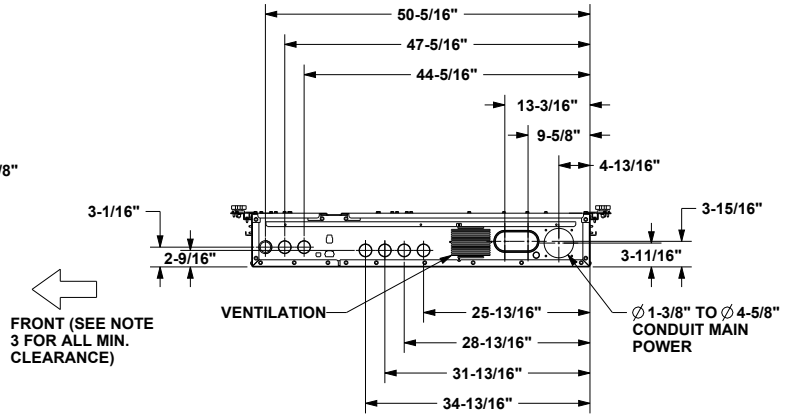
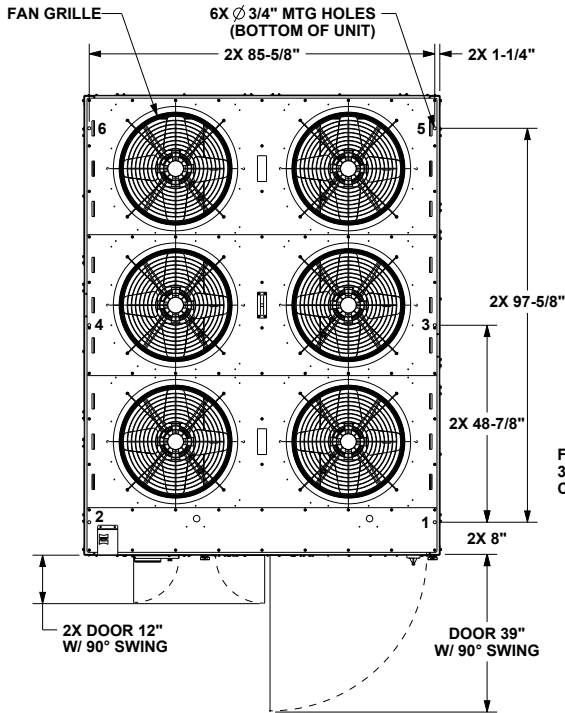
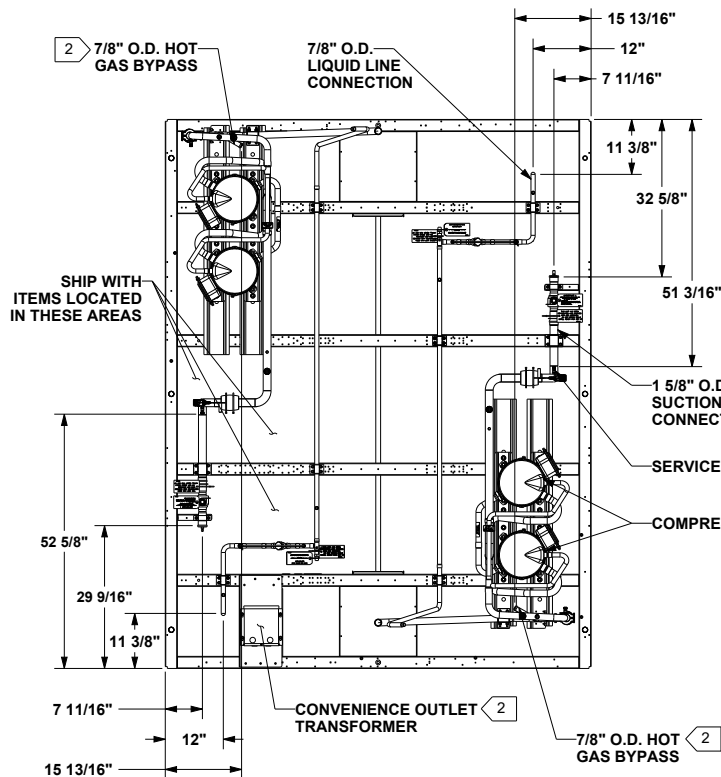
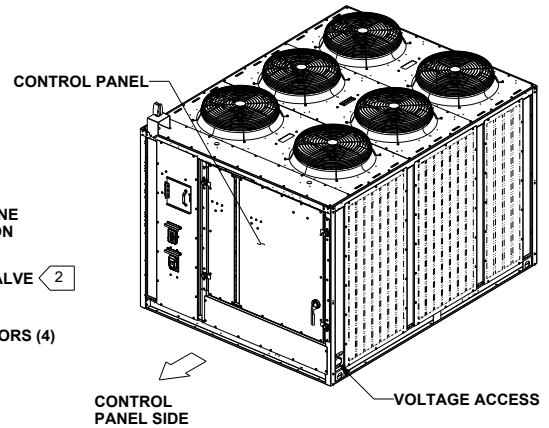

Figure 16. Air-cooled condensing unit connections — 60 ton



NOTES:

1. VERIFY WEIGHT, CONNECTION, AND ALL DIMENSIONS WITH INSTALLER DOCUMENTS BEFORE INSTALLATION.
2. OPTIONS ONLY COME WITH SELECTED UNITS.
3. DUAL CIRCUIT UNIT REQUIRES TWO SEPARATE LINE SETS (TWO SUCTION LINES AND TWO LIQUID LINES).



CONTROL PANEL SIDE

PLAN VIEW OF UNIT
CONNECTION DRAWING

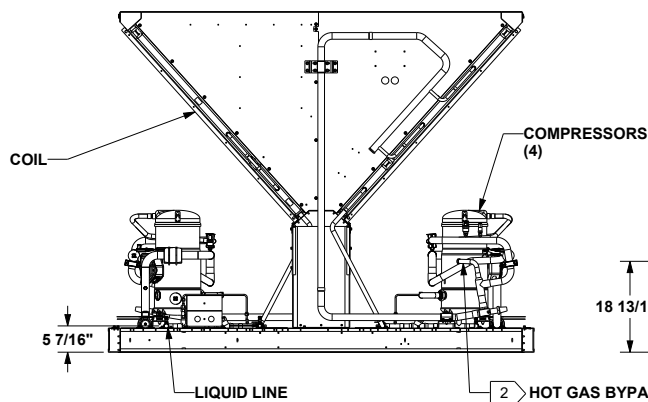

CONTROL PANEL SIDE VIEW OF UNIT
CONNECTION DRAWING

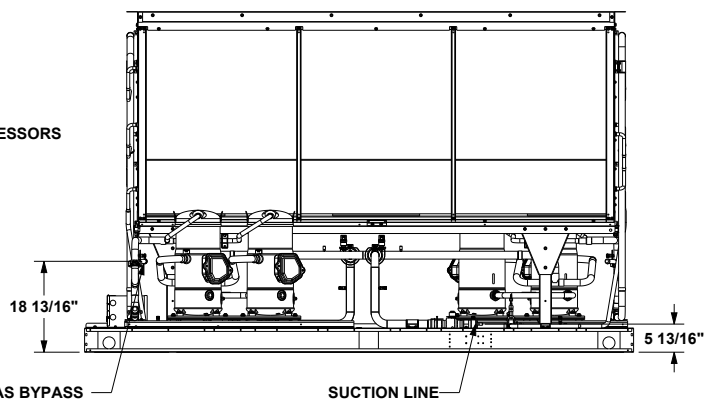

FRONT VIEW OF UNIT
CONNECTION DRAWING

60 TON UNIT
DIMENSION CONNECTION DRAWING

Dimensions and Weights

Figure 17. Air-cooled condensing unit — 80 ton

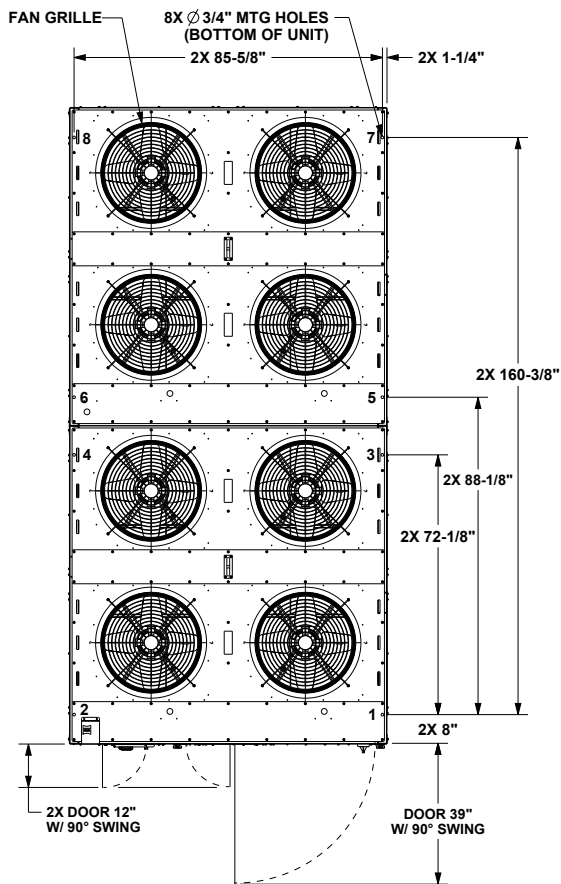

NOTES:

1. SEE CONNECTION DRAWING FOR CONNECTION LOCATION AND SIZES.
2. OPTIONS ONLY COME WITH SELECTED UNITS.
3. FRONT OF UNIT CLEARANCE 72". BACK OF UNIT CLEARANCE 72". LEFT AND RIGHT SIDE OF UNIT CLEARANCE 48".
4. VOLTAGE ACCESS HOLES IN OUTER PANEL MUST BE COVERED AFTER UNIT INSTALLATION.
5. TD7 CONTROL ONLY COMES WITH SELECTED UNITS.

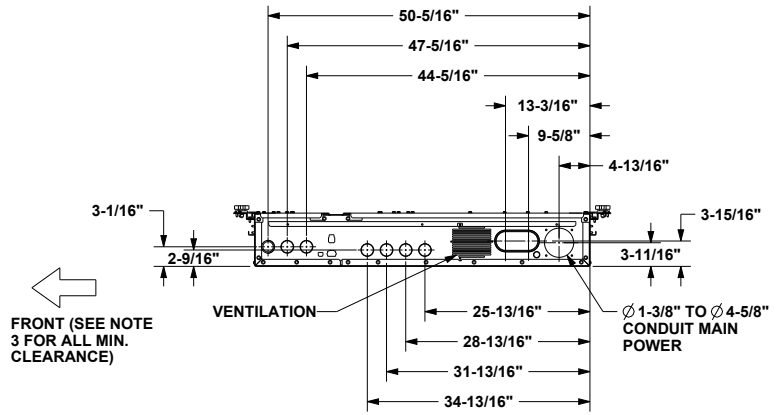

DETAIL A

CONTROL BOX BOTTOM

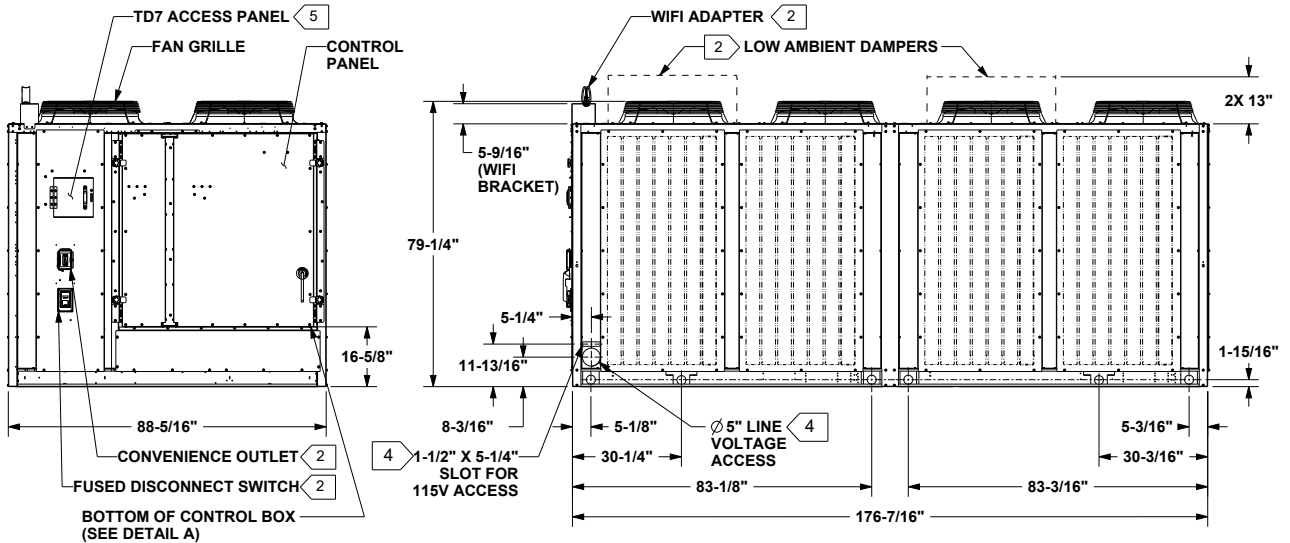
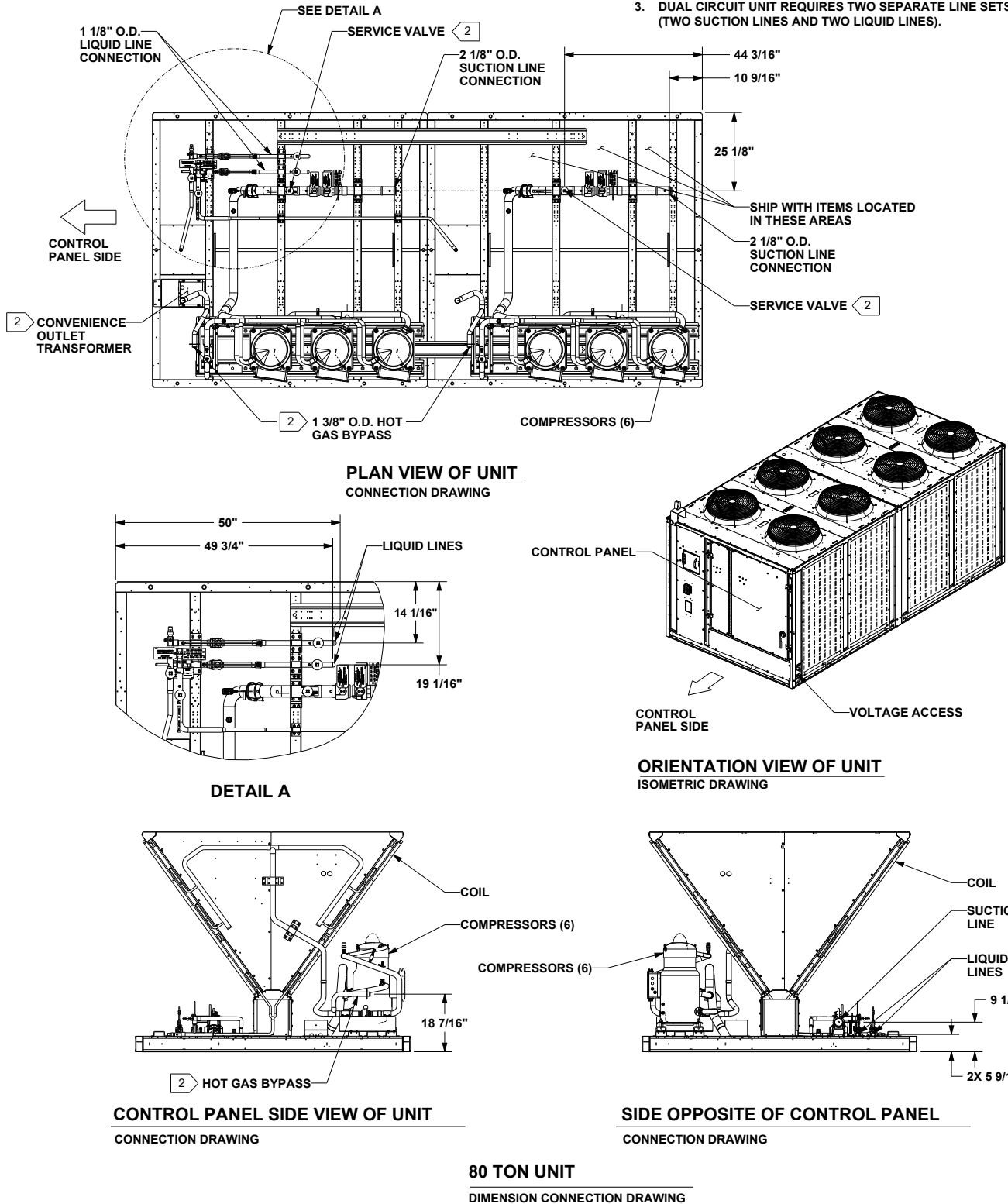

Figure 18. Air-cooled condensing unit connections — 80 ton

NOTES:

1. VERIFY WEIGHT, CONNECTION, AND ALL DIMENSIONS WITH INSTALLER DOCUMENTS BEFORE INSTALLATION. OPTIONS ONLY COME WITH SELECTED UNITS.
2. DUAL CIRCUIT UNIT REQUIRES TWO SEPARATE LINE SETS (TWO SUCTION LINES AND TWO LIQUID LINES).





Dimensions and Weights

Figure 19. Air-cooled condensing unit — 100 and 120 tons

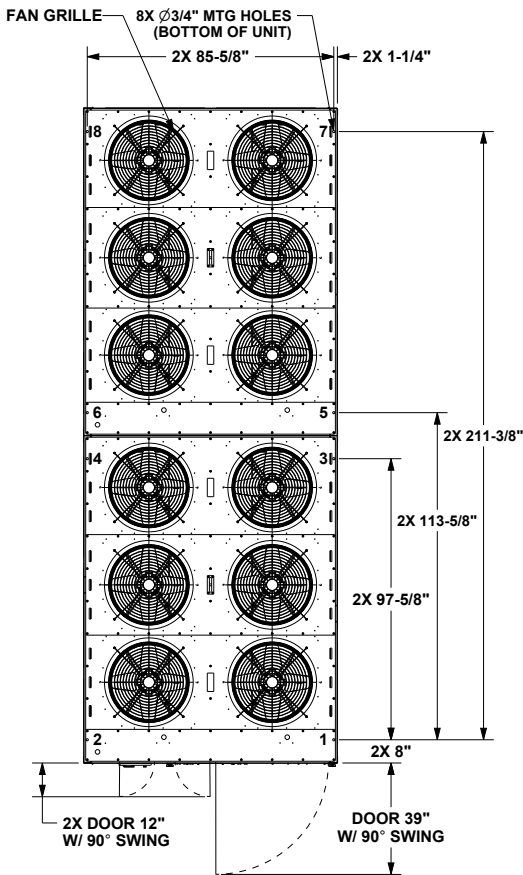

NOTES:

1. SEE CONNECTION DRAWING FOR CONNECTION LOCATION AND SIZES.
2. OPTIONS ONLY COME ON SELECTED UNITS.
3. FRONT AND BACK OF UNIT CLEARANCE 72". LEFT AND RIGHT SIDE OF UNIT CLEARANCE 48"
4. VOLTAGE ACCESS HOLES IN OUTER PANEL MUST BE COVERED AFTER UNIT INSTALLATION

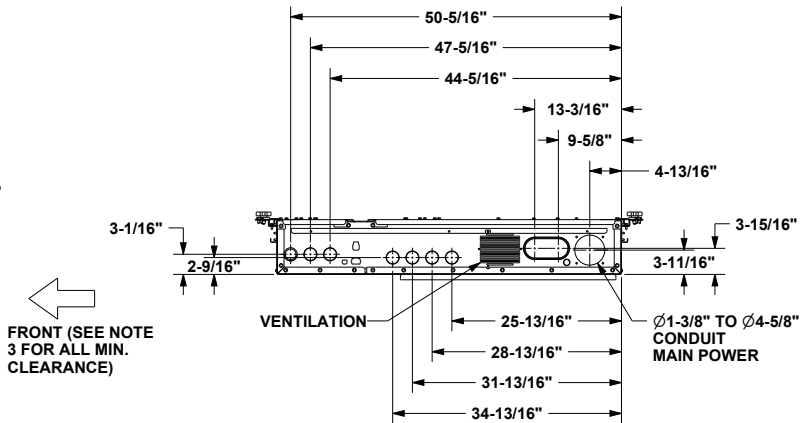

DETAIL A

CONTROL BOX BOTTOM

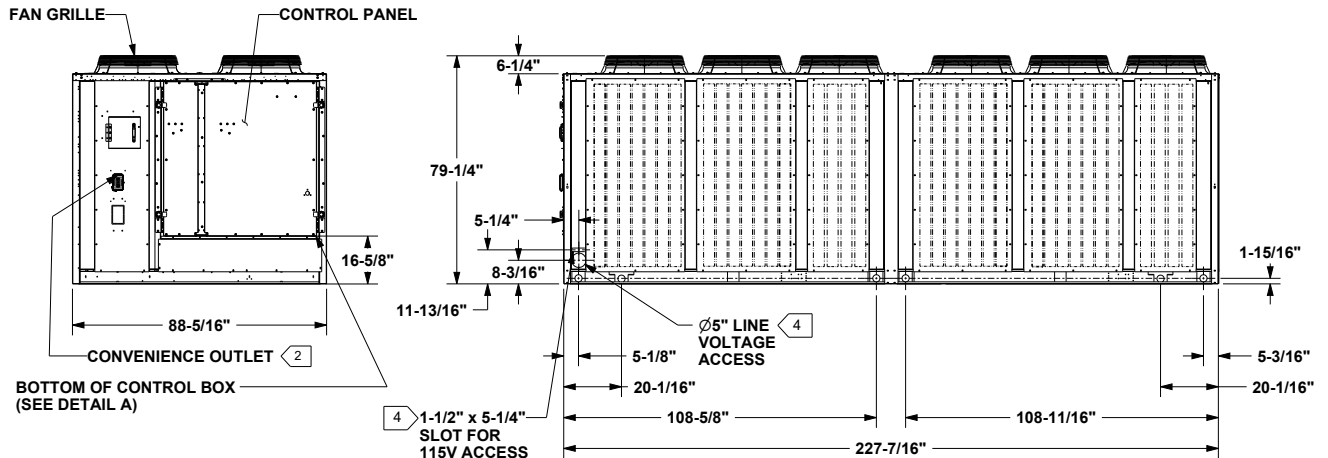
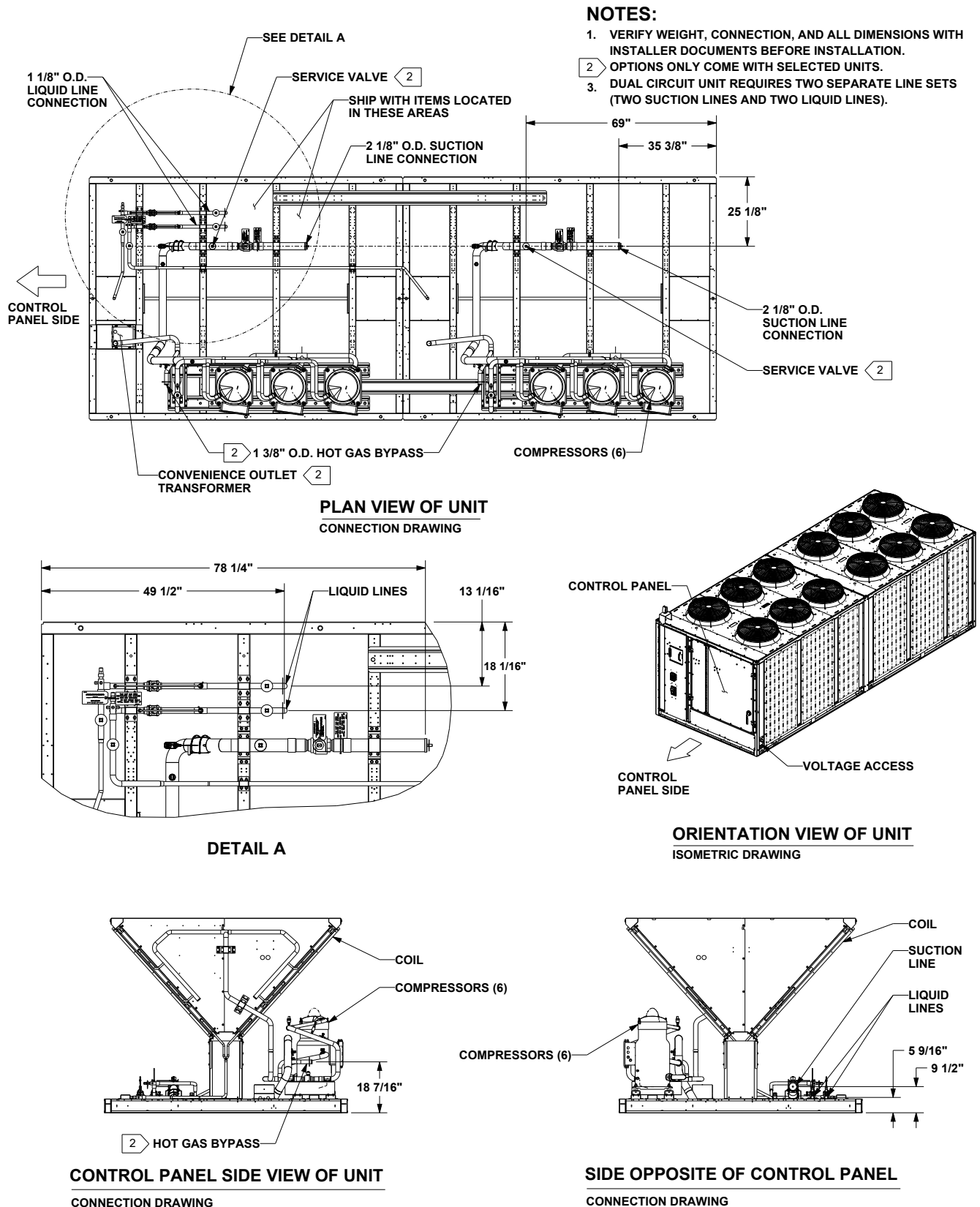

Figure 20. Air-cooled condensing unit connections — 100 and 120 tons



100 AND 120 TON UNITS
DIMENSION CONNECTION DRAWING



Dimensions and Weights

Figure 21. Evaporator chiller — 20 ton

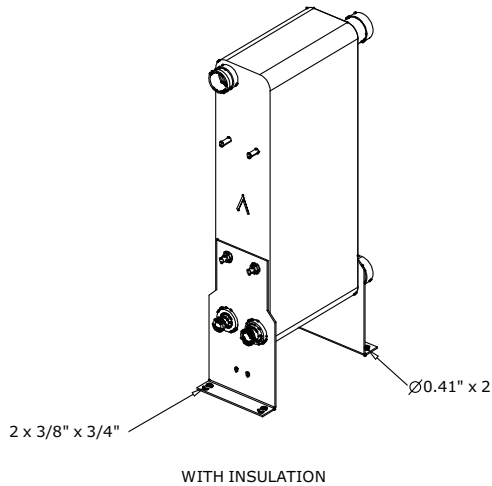

NOTES:

1. THIS HEAT EXCHANGER IS INTENDED FOR INDOOR INSTALLATION ONLY
2. HEAT EXCHANGER MOUNTING LEGS ARE INSTALLED AT JOB SITE WITH SUPPLIED FASTENERS
3. INSULATION SHOULD BE INSTALLED AFTER INSTALLING LEGS & REFRIGERANT TUBING, OR MUST BE ADEQUATELY SHIELDED AGAINST HEAT WHEN BRAZING REFRIGERANT LINES
4. INSTALL INSULATION SIDE PIECES FIRST THEN WRAPPER (MAY REQUIRE TRIMMING)
5. USE VINYL TAPE (FIELD SUPPLIED) TO SEAL INSULATION AFTER INSTALLATION
6. WATER CONNECTIONS ARE GROOVED (VICTAULIC)
7. REFRIGERANT CONNECTIONS ARE STAINLESS STEEL AND REQUIRE SPECIAL BRAZE MATERIALS. SEE IOM BRAZE PROCEDURE.
8. 1/2" X 14 NPT F4 CONNECTION SUPPLIED ON EXT 04 THRU 06 AND 08 10 ONLY BRAZED PLATE HEAT EXCHANGER REMOTE CHILLER EVAPORATOR OPTION

OPTION INCLUDES:

- 1 - BRAZED PLATE HEAT EXCHANGER - SHIPS SEPARATE FROM CONDENSING UNIT
- 1 - INSTALLATION KIT, TO INCLUDE:
 - 2 - MOUNTING BRACKETS
 - 1 - INSULATION KIT
 - 1 - MOUNTING BRACKET & INSULATION KIT INSTALLATION INSTRUCTIONS
- 1 - WATER CONNECTION KIT WITH PIPING STUBS, Y CONNECTOR, STRAINER, VICTAULIC CONNECTIONS WITH GASKETS, WATER FLOW SWITCH
- 1 - WATER CONNECTION KIT INSTALLATION INSTRUCTIONS

INSTALLATION ADDITIONALLY REQUIRES:

- EVP REMOTE PANEL WITH LEAVING WATER TEMPERATURE SENSOR, FREEZE-STAT, AND INSTALLATION INSTRUCTIONS
- 4 - FIELD PROVIDED 7/16" BOLTS FOR SECURING BRAZED PLATE HEAT EXCHANGER TO PERMANENT MOUNTING SURFACE
- 2 - FIELD PROVIDED 1/2" - 14 NPTE PLUGS, STAINLESS STEEL OR PVC
- FIELD PROVIDED TEFLON TAPE FOR SEALING 1/2" PIPE PLUGS
- FIELD PROVIDED WATER STRAINER PLUG OR BLOW DOWN VALVE
- FIELD PROVIDED TEE FOR INSTALLING WATER FLOW SWITCH
- FIELD PROVIDED 2" VINYL TAPE FOR SEALING INSULATION SEAMS

SEE IOM FOR INSTALLATION DETAIL

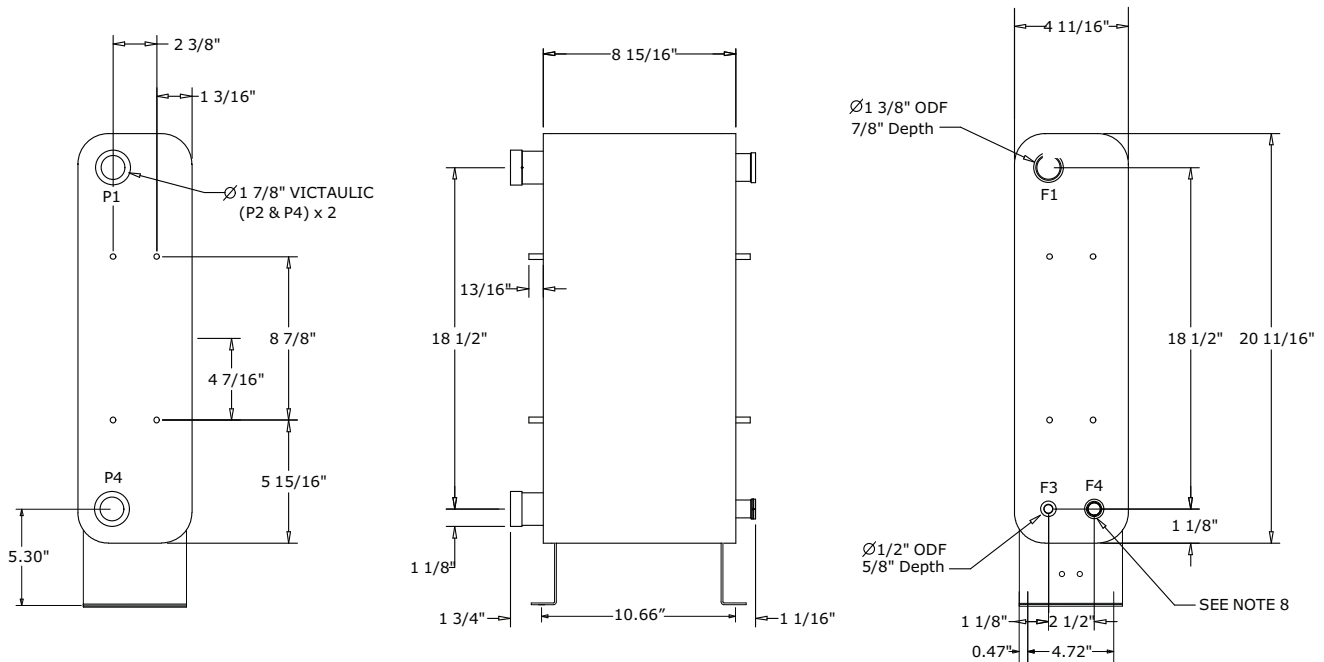

20 TON BRAZED PLATE HEAT EXCHANGER

ACCESSORY DRAWING

Figure 22. Evaporator chiller — 25 ton

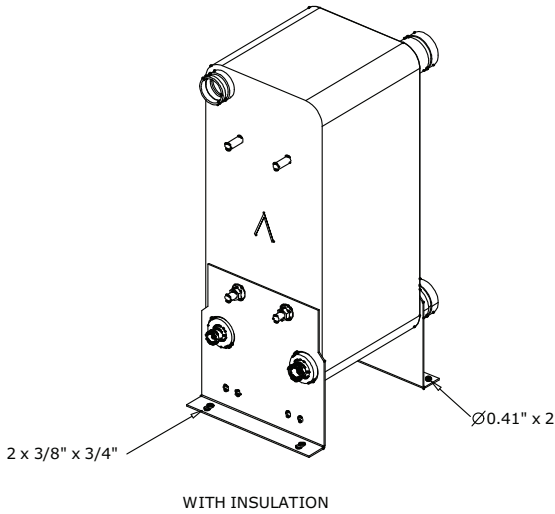

NOTES:

1. THIS HEAT EXCHANGER IS INTENDED FOR INDOOR INSTALLATION ONLY
2. HEAT EXCHANGER MOUNTING LEGS ARE INSTALLED AT JOB SITE WITH SUPPLIED FASTENERS
3. INSULATION SHOULD BE INSTALLED AFTER INSTALLING LEGS & REFRIGERANT TUBING, OR MUST BE ADEQUATELY SHIELDED AGAINST HEAT WHEN BRAZING REFRIGERANT LINES
4. INSTALL INSULATION SIDE PIECES FIRST THEN WRAPPER MAY REQUIRE TRIMMING)
5. USE VINYL TAPE (FIELD SUPPLIED) TO SEAL INSULATION AFTER INSTALLATION
6. WATER CONNECTIONS ARE GROOVED (VICTAULIC)
7. REFRIGERANT CONNECTIONS ARE STAINLESS STEEL AND REQUIRE SPECIAL BRAZE MATERIALS. SEE IOM BRAZE PROCEDURE.
8. 1/2" - 14 NPT F4 CONNECTION SUPPLIED ON EXT'S 05 THRU 08 AND 13 THRU 16 ONLY.

BRAZED PLATE HEAT EXCHANGER REMOTE CHILLER EVAPORATOR OPTION

OPTION INCLUDES:

- 1 - BRAZED PLATE HEAT EXCHANGER - SHIPS SEPARATE FROM CONDENSING UNIT
- 1 - INSTALLATION KIT, TO INCLUDE:
 - 2 - MOUNTING BRACKETS
 - 1 - INSULATION KIT
 - 1 - MOUNTING BRACKET & INSULATION KIT INSTALLATION INSTRUCTIONS
- 1 - WATER CONNECTION KIT WITH PIPING STUBS, Y CONNECTOR, STRAINER, WATER FLOW SWITCH
- 1 - WATER CONNECTION KIT INSTALLATION INSTRUCTIONS

INSTALLATION ADDITIONALLY REQUIRES:

- EVP REMOTE PANEL WITH LEAVING WATER TEMPERATURE SENSOR, FREEZE-STAT, AND INSTALLATION INSTRUCTIONS
- 4 - FIELD PROVIDED 7/16" BOLTS FOR SECURING BRAZED PLATE HEAT EXCHANGER TO PERMANENT MOUNTING SURFACE
- 2 - FIELD PROVIDED 1/2" - 14 NPT PLUGS, STAINLESS STEEL OR PVC
- FIELD PROVIDED TEFLON TAPE FOR SEALING 1/2" PIPE PLUGS
- FIELD PROVIDED WATER STRAINER PLUG OR BLOW DOWN VALVE
- FIELD PROVIDED TEE FOR INSTALLING WATER FLOW SWITCH
- FIELD PROVIDED 2" VINYL TAPE FOR SEALING INSULATION SEAMS

SEE IOM FOR INSTALLATION DETAIL

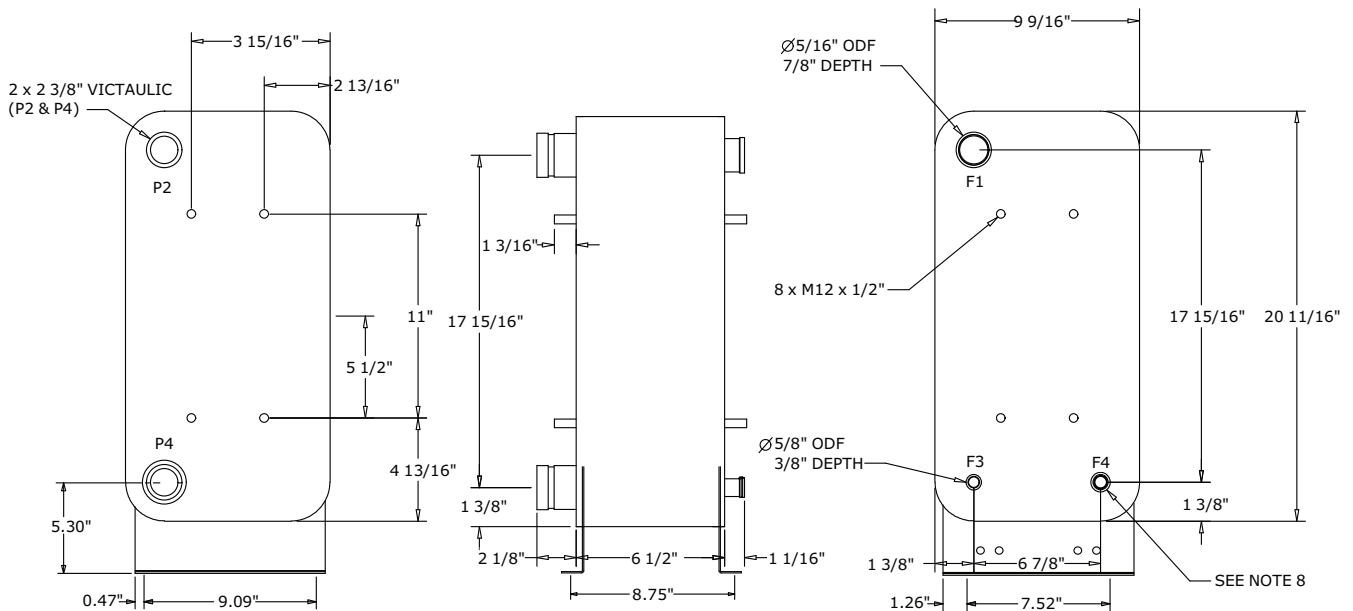

25 TON BRAZED PLATE HEAT EXCHANGER

ACCESSORY DRAWING



Dimensions and Weights

Figure 23. Evaporator chiller — 30 ton (R-410A)

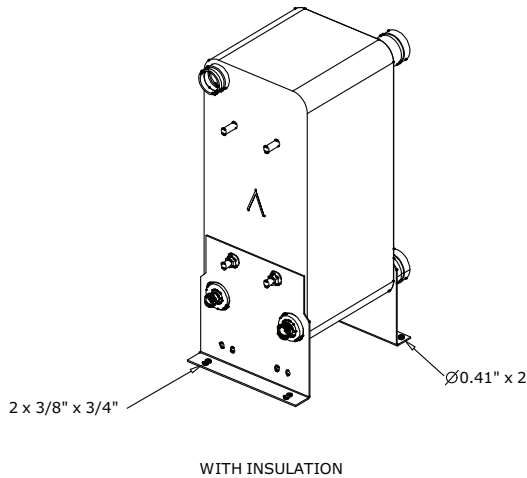

NOTES:

1. THIS HEAT EXCHANGER IS INTENDED FOR INDOOR INSTALLATION ONLY
2. HEAT EXCHANGER MOUNTING LEGS ARE INSTALLED AT JOB SITE WITH SUPPLIED FASTENERS
3. INSULATION SHOULD BE INSTALLED AFTER INSTALLING LEGS & REFRIGERANT TUBING, OR MUST BE ADEQUATELY SHIELDED AGAINST HEAT WHEN BRAZING REFRIGERANT LINES
4. INSTALL INSULATION SIDE PIECES FIRST THEN WRAPPER (MAY REQUIRE TRIMMING)
5. USE VINYL TAPE (FIELD SUPPLIED) TO SEAL INSULATION AFTER INSTALLATION
6. WATER CONNECTIONS ARE GROOVED (VICTAULIC)
7. REFRIGERANT CONNECTIONS ARE STAINLESS STEEL AND REQUIRE SPECIAL BRAZE MATERIALS. SEE IOM BRAZE PROCEDURE.
8. 1/2" - 14 NPT F4 CONNECTION SUPPLIED ON EXT'S 05 THRU 08 AND 13 THRU 16 ONLY.

BRAZED PLATE HEAT EXCHANGER REMOTE CHILLER EVAPORATOR OPTION

OPTION INCLUDES:

- 1 - BRAZED PLATE HEAT EXCHANGER - SHIPS SEPARATE FROM RAUJ CONDENSING UNIT
- 1 - INSTALLATION KIT, TO INCLUDE:
 - 2 - MOUNTING BRACKETS
 - 1 - INSULATION KIT
 - 1 - MOUNTING BRACKET & INSULATION KIT INSTALLATION INSTRUCTIONS
- 1 - WATER CONNECTION KIT WITH PIPING STUBS, Y CONNECTOR, STRAINER, VICTAULIC CONNECTIONS WITH GASKETS, WATER FLOW SWITCH
- 1 - WATER CONNECTION KIT INSTALLATION INSTRUCTIONS

INSTALLATION ADDITIONALLY REQUIRES:

- RAUJ REMOTE EVP CONTROL PANEL WITH LEAVING WATER TEMPERATURE SENSOR, FREEZE-STAT, AND INSTALLATION INSTRUCTIONS - ALL INCLUDED WITH REMOTE EVP CONTROL PANEL
- 4 - FIELD PROVIDED 7/16" BOLTS FOR SECURING BRAZED PLATE HEAT EXCHANGER TO PERMANENT MOUNTING SURFACE
- 2 - FIELD PROVIDED 1/2" - 14 NPTE PLUGS, STAINLESS STEEL OR PVC
- FIELD PROVIDED TEFLON TAPE FOR SEALING 1/2" PIPE PLUGS
- FIELD PROVIDED WATER STRAINER PLUG OR BLOW DOWN VALVE
- FIELD PROVIDED TEE FOR INSTALLING WATER FLOW SWITCH
- FIELD PROVIDED 2" VINYL TAPE FOR SEALING INSULATION SEAMS

SEE IOM FOR INSTALLATION DETAIL

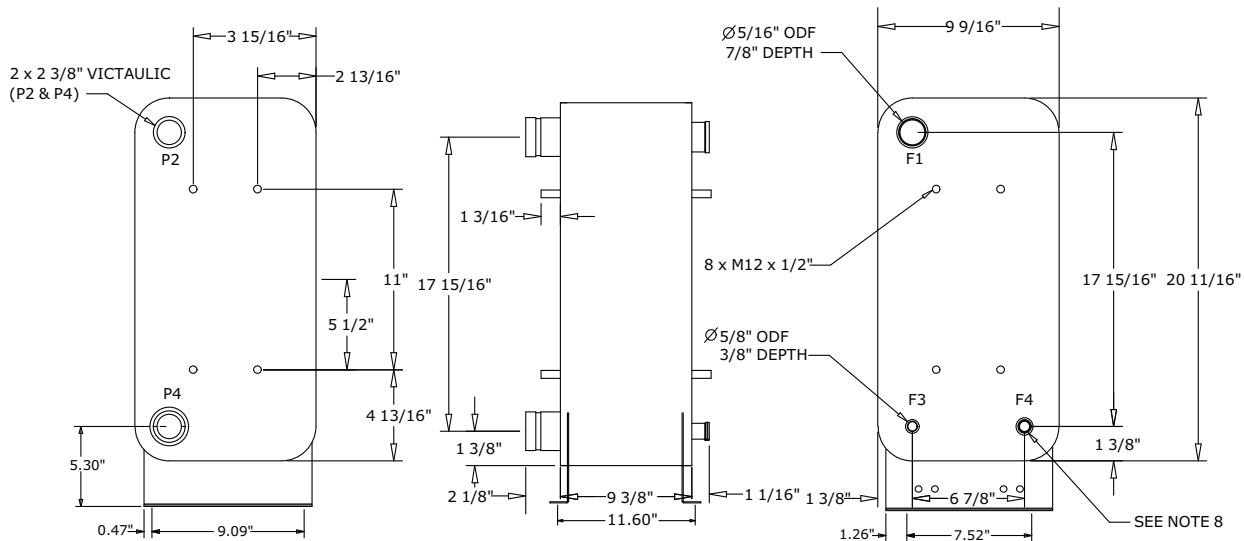

30 TON BRAZED PLATE HEAT EXCHANGER

ACCESSORY DRAWING

Figure 24. Evaporator chiller — 30 ton (R-454B)

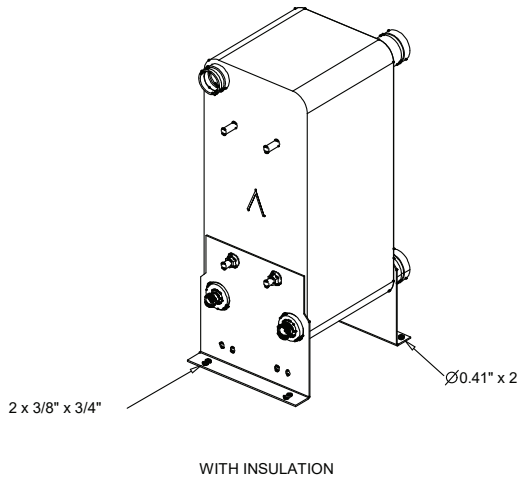

NOTES:

1. THIS HEAT EXCHANGER IS INTENDED FOR INDOOR INSTALLATION ONLY
2. HEAT EXCHANGER MOUNTING LEGS ARE INSTALLED AT JOB SITE WITH SUPPLIED FASTENERS
3. INSULATION SHOULD BE INSTALLED AFTER INSTALLING LEGS & REFRIGERANT TUBING, OR MUST BE ADEQUATELY SHIELDED AGAINST HEAT WHEN BRAZING REFRIGERANT LINES
4. INSTALL INSULATION SIDE PIECES FIRST THEN WRAPPER (MAY REQUIRE TRIMMING)
5. USE VINYL TAPE (FIELD SUPPLIED) TO SEAL INSULATION AFTER INSTALLATION
6. WATER CONNECTIONS ARE GROOVED (VICTAULIC)
7. REFRIGERANT CONNECTIONS ARE STAINLESS STEEL AND REQUIRE SPECIAL BRAZE MATERIALS. SEE IOM BRAZE PROCEDURE.
8. 1/2" - 14 NPT F4 CONNECTION SUPPLIED ON EXT'S 05 THRU 08 AND 13 THRU 16 ONLY.

BRAZED PLATE HEAT EXCHANGER REMOTE CHILLER EVAPORATOR OPTION

OPTION INCLUDES:

- 1 - BRAZED PLATE HEAT EXCHANGER - SHIPS SEPARATE FROM CONDENSING UNIT
- 1 - INSTALLATION KIT, TO INCLUDE:
 - 2 - MOUNTING BRACKETS
 - 1 - INSULATION KIT
 - 1 - MOUNTING BRACKET & INSULATION KIT INSTALLATION INSTRUCTIONS
- 1 - WATER CONNECTION KIT WITH PIPING STUBS, Y CONNECTOR, STRAINER, VICTAULIC CONNECTIONS WITH GASKETS, WATER FLOW SWITCH
- 1 - WATER CONNECTION KIT INSTALLATION INSTRUCTIONS

INSTALLATION ADDITIONALLY REQUIRES:

- EVP REMOTE PANEL WITH LEAVING WATER TEMPERATURE SENSOR, FREEZE-STAT, AND INSTALLATION INSTRUCTIONS
- 4 - FIELD PROVIDED 7/16" BOLTS FOR SECURING BRAZED PLATE HEAT EXCHANGER TO PERMANENT MOUNTING SURFACE
- 2 - FIELD PROVIDED 1/2" - 14 NPTE PLUGS, STAINLESS STEEL OR PVC
- FIELD PROVIDED TEFLON TAPE FOR SEALING 1/2" PIPE PLUGS
- FIELD PROVIDED WATER STRAINER PLUG OR BLOW DOWN VALVE
- FIELD PROVIDED TEE FOR INSTALLING WATER FLOW SWITCH
- FIELD PROVIDED 2" VINYL TAPE FOR SEALING INSULATION SEAMS

SEE IOM FOR INSTALLATION DETAIL

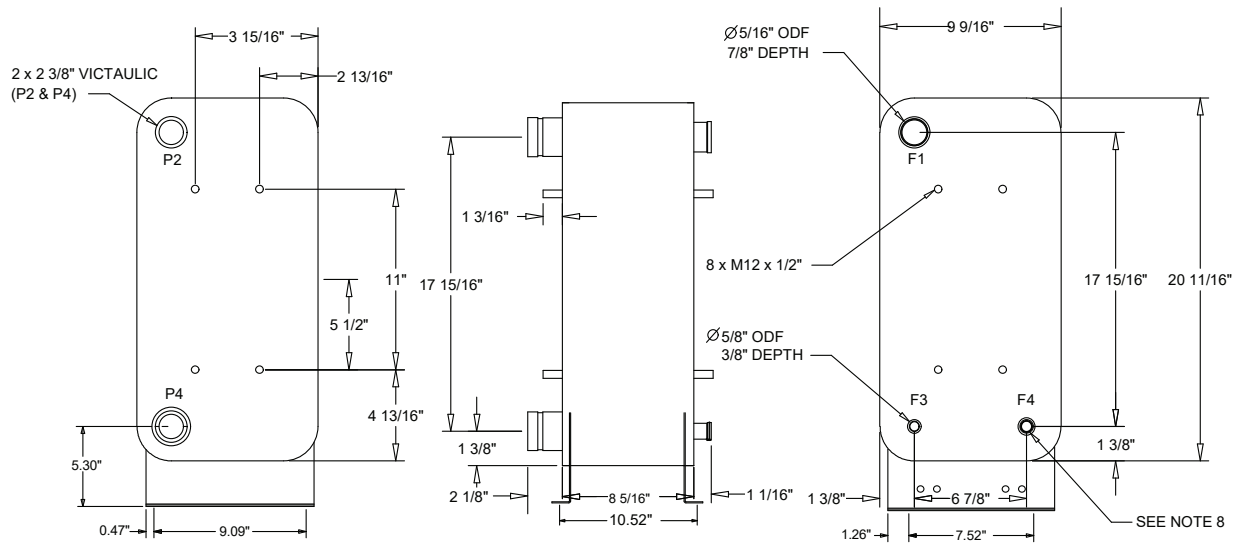

30 TON BRAZED PLATE HEAT EXCHANGER

ACCESSORY DRAWING



Dimensions and Weights

Figure 25. Evaporator chiller — 40 ton (R-410A)

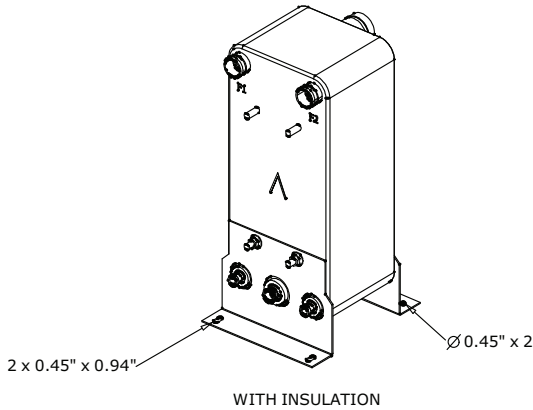

NOTES:

1. THIS HEAT EXCHANGER IS INTENDED FOR INDOOR INSTALLATION ONLY
2. HEAT EXCHANGER MOUNTING LEGS ARE INSTALLED AT JOB SITE WITH SUPPLIED FASTENERS
3. INSULATION SHOULD BE INSTALLED AFTER INSTALLING LEGS & REFRIGERANT TUBING, OR MUST BE ADEQUATELY SHIELDED AGAINST HEAT WHEN BRAZING REFRIGERANT LINES
4. INSTALL INSULATION SIDE PIECES FIRST THEN WRAPPER (MAY REQUIRE TRIMMING)
5. USE VINYL TAPE (FIELD SUPPLIED) TO SEAL INSULATION AFTER INSTALLATION
6. WATER CONNECTIONS ARE GROOVED (VICTAULIC)
7. REFRIGERANT CONNECTIONS ARE STAINLESS STEEL AND REQUIRE SPECIAL BRAZE MATERIALS. SEE IOM BRAZE PROCEDURE.
8. 1/2" NPT F5 CONNECTION SUPPLIED ON EXT'S 04 THRU 06 ONLY
BRAZED PLATE HEAT EXCHANGER REMOTE CHILLER EVAPORATOR OPTION

OPTION INCLUDES:

- 1 - BRAZED PLATE HEAT EXCHANGER - SHIPS SEPARATE FROM RAUJ CONDENSING UNIT
- 1 - INSTALLATION KIT, TO INCLUDE:
 - 2 - MOUNTING BRACKETS
 - 1 - INSULATION KIT
 - 1 - MOUNTING BRACKET & INSULATION KIT INSTALLATION INSTRUCTIONS
- 1 - WATER CONNECTION KIT WITH PIPING STUBS, Y CONNECTOR, STRAINER, VICTAULIC CONNECTIONS WITH GASKETS, WATER FLOW SWITCH
- 1 - WATER CONNECTION KIT INSTALLATION INSTRUCTIONS

INSTALLATION ADDITIONALLY REQUIRES:

- RAUJ REMOTE EVP CONTROL PANEL WITH LEAVING WATER TEMPERATURE SENSOR, FREEZE-STAT, AND INSTALLATION INSTRUCTIONS - ALL INCLUDED WITH REMOTE EVP CONTROL PANEL
- 4 - FIELD PROVIDED 7/16" BOLTS FOR SECURING BRAZED PLATE HEAT EXCHANGER TO PERMANENT MOUNTING SURFACE
- 2 - FIELD PROVIDED 1/2" - 14 NPTE PLUGS, STAINLESS STEEL OR PVC
- FIELD PROVIDED TEFLON TAPE FOR SEALING 1/2" PIPE PLUGS
- FIELD PROVIDED WATER STRAINER PLUG OR BLOW DOWN VALVE
- FIELD PROVIDED TEE FOR INSTALLING WATER FLOW SWITCH
- FIELD PROVIDED 2" VINYL TAPE FOR SEALING INSULATION SEAMS

SEE IOM FOR INSTALLATION DETAIL

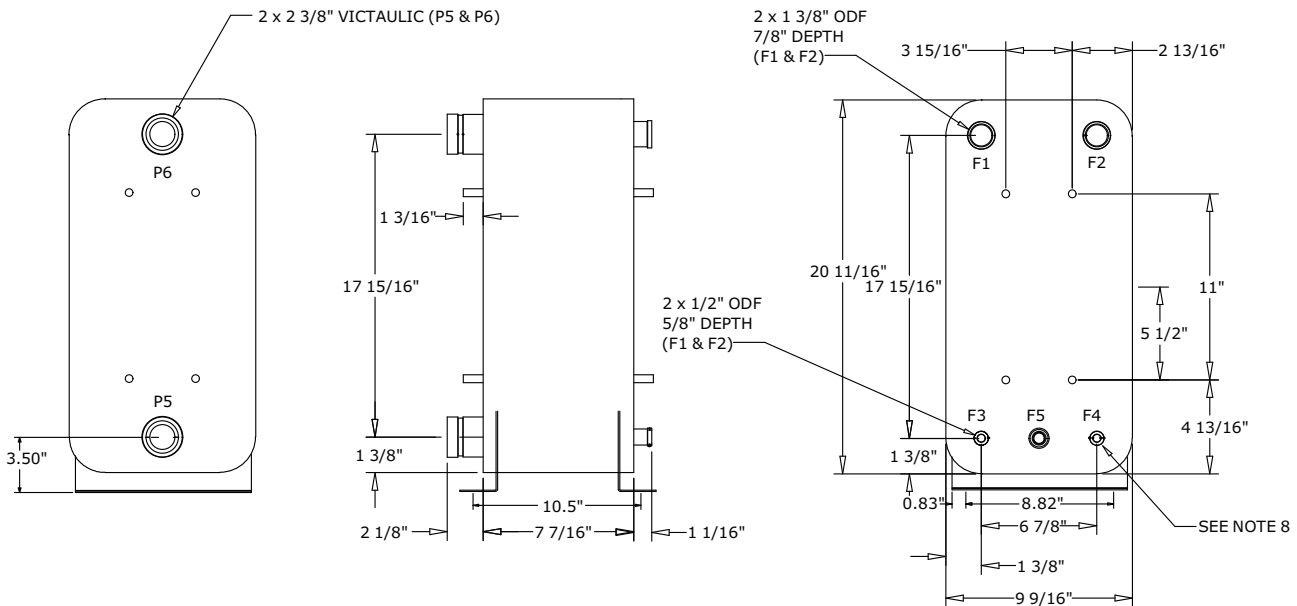

40 TON BRAZED PLATE HEAT EXCHANGER

ACCESSORY DRAWING

Figure 26. Evaporator chiller — 40 ton (R-454B)

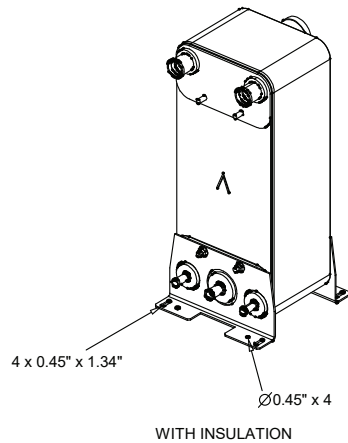

NOTES:

1. THIS HEAT EXCHANGER IS INTENDED FOR INDOOR INSTALLATION ONLY
2. HEAT EXCHANGER MOUNTING LEGS ARE INSTALLED AT JOB SITE WITH SUPPLIED FASTENERS
3. INSULATION SHOULD BE INSTALLED AFTER INSTALLING LEGS & REFRIGERANT TUBING, OR MUST BE ADEQUATELY SHIELDED AGAINST HEAT WHEN BRAZING REFRIGERANT LINES
4. INSTALL INSULATION SIDE PIECES FIRST THEN WRAPPER (MAY REQUIRE TRIMMING)
5. USE VINYL TAPE (FIELD SUPPLIED) TO SEAL INSULATION AFTER INSTALLATION
6. WATER CONNECTIONS ARE GROOVED (VICTAULIC)
7. REFRIGERANT CONNECTIONS ARE STAINLESS STEEL AND REQUIRE SPECIAL BRAZE MATERIALS. SEE IOM BRAZE PROCEDURE.
8. 1/2" - 14 NPT F5 CONNECTION SUPPLIED ON EXT'S 13 THRU 24 AND 37 THRU 48 ONLY.

BRAZED PLATE HEAT EXCHANGER REMOTE CHILLER EVAPORATOR OPTION

OPTION INCLUDES:

- 1 - BRAZED PLATE HEAT EXCHANGER - SHIPS SEPARATE FROM CONDENSING UNIT
- 1 - INSTALLATION KIT, TO INCLUDE:
 - 2 - MOUNTING BRACKETS
 - 1 - INSULATION KIT
 - 1 - MOUNTING BRACKET & INSULATION KIT INSTALLATION INSTRUCTIONS
- 1 - WATER CONNECTION KIT WITH PIPING STUBS, Y CONNECTOR, STRAINER, VICTAULIC CONNECTIONS WITH GASKETS, WATER FLOW SWITCH
- 1 - WATER CONNECTION KIT INSTALLATION INSTRUCTIONS

INSTALLATION ADDITIONALLY REQUIRES:

- EVP REMOTE PANEL WITH LEAVING WATER TEMPERATURE SENSOR, FREEZE-STAT, AND INSTALLATION INSTRUCTIONS
- 4 - FIELD PROVIDED 7/16" BOLTS FOR SECURING BRAZED PLATE HEAT EXCHANGER TO PERMANENT MOUNTING SURFACE
- 2 - FIELD PROVIDED 1/2" - 14 NPTE PLUGS, STAINLESS STEEL OR PVC
- FIELD PROVIDED TEFLON TAPE FOR SEALING 1/2" PIPE PLUGS
- FIELD PROVIDED WATER STRAINER PLUG OR BLOW DOWN VALVE
- FIELD PROVIDED TEE FOR INSTALLING WATER FLOW SWITCH
- FIELD PROVIDED 2" VINYL TAPE FOR SEALING INSULATION SEAMS

SEE IOM FOR INSTALLATION DETAIL

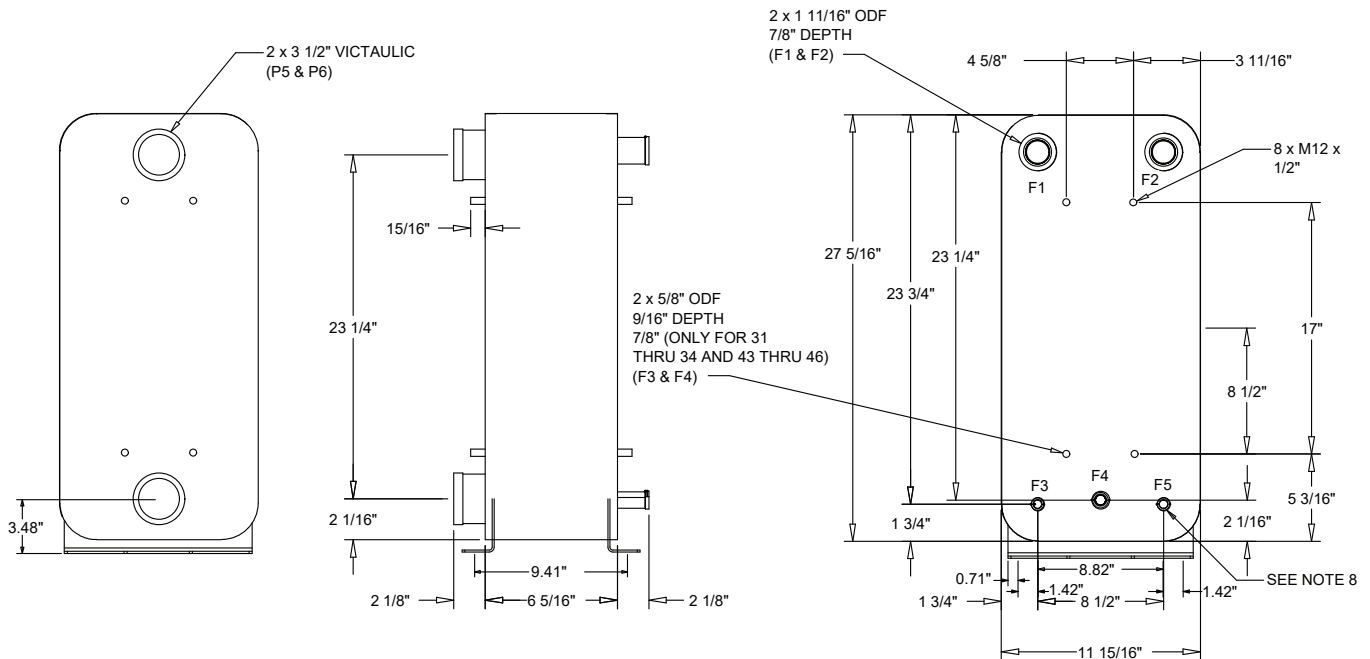

40 TON BRAZED PLATE HEAT EXCHANGER

ACCESSORY DRAWING



Dimensions and Weights

Figure 27. Evaporator chiller — 50 ton

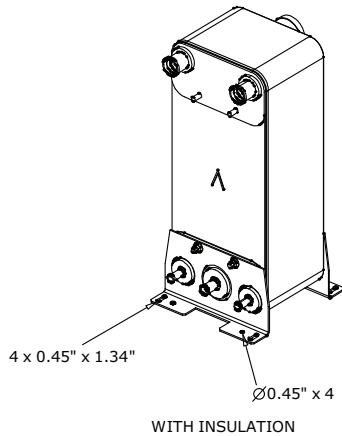

NOTES:

1. THIS HEAT EXCHANGER IS INTENDED FOR INDOOR INSTALLATION ONLY
2. HEAT EXCHANGER MOUNTING LEGS ARE INSTALLED AT JOB SITE WITH SUPPLIED FASTENERS
3. INSULATION SHOULD BE INSTALLED AFTER INSTALLING LEGS & REFRIGERANT TUBING, OR MUST BE ADEQUATELY SHIELDED AGAINST HEAT WHEN BRAZING REFRIGERANT LINES
4. INSTALL INSULATION SIDE PIECES FIRST THEN WRAPPER (MAY REQUIRE TRIMMING)
5. USE VINYL TAPE (FIELD SUPPLIED) TO SEAL INSULATION AFTER INSTALLATION
6. WATER CONNECTIONS ARE GROOVED (VICTAULIC)
7. REFRIGERANT CONNECTIONS ARE STAINLESS STEEL AND REQUIRE SPECIAL BRAZE MATERIALS. SEE IOM BRAZE PROCEDURE.
8. 1/2" - 14 NPT F5 CONNECTION SUPPLIED ON EXT'S 13 THRU 24 AND 37 THRU 48 ONLY.

BRAZED PLATE HEAT EXCHANGER REMOTE CHILLER EVAPORATOR OPTION

OPTION INCLUDES:

- 1 - BRAZED PLATE HEAT EXCHANGER - SHIPS SEPARATE FROM CONDENSING UNIT
- 1 - INSTALLATION KIT, TO INCLUDE:
 - 2 - MOUNTING BRACKETS
 - 1 - INSULATION KIT
 - 1 - MOUNTING BRACKET & INSULATION KIT INSTALLATION INSTRUCTIONS
- 1 - WATER CONNECTION KIT WITH PIPING STUBS, Y CONNECTOR, STRAINER, VICTAULIC CONNECTIONS WITH GASKETS, WATER FLOW SWITCH
- 1 - WATER CONNECTION KIT INSTALLATION INSTRUCTIONS

INSTALLATION ADDITIONALLY REQUIRES:

- EVP REMOTE PANEL WITH LEAVING WATER TEMPERATURE SENSOR, FREEZE-STAT, AND INSTALLATION INSTRUCTIONS
- 4 - FIELD PROVIDED 7/16" BOLTS FOR SECURING BRAZED PLATE HEAT EXCHANGER TO PERMANENT MOUNTING SURFACE
- 2 - FIELD PROVIDED 1/2" - 14 NPTE PLUGS, STAINLESS STEEL OR PVC
- FIELD PROVIDED TEFLON TAPE FOR SEALING 1/2" PIPE PLUGS
- FIELD PROVIDED WATER STRAINER PLUG OR BLOW DOWN VALVE
- FIELD PROVIDED TEE FOR INSTALLING WATER FLOW SWITCH
- FIELD PROVIDED 2" VINYL TAPE FOR SEALING INSULATION SEAMS

SEE IOM FOR INSTALLATION DETAIL

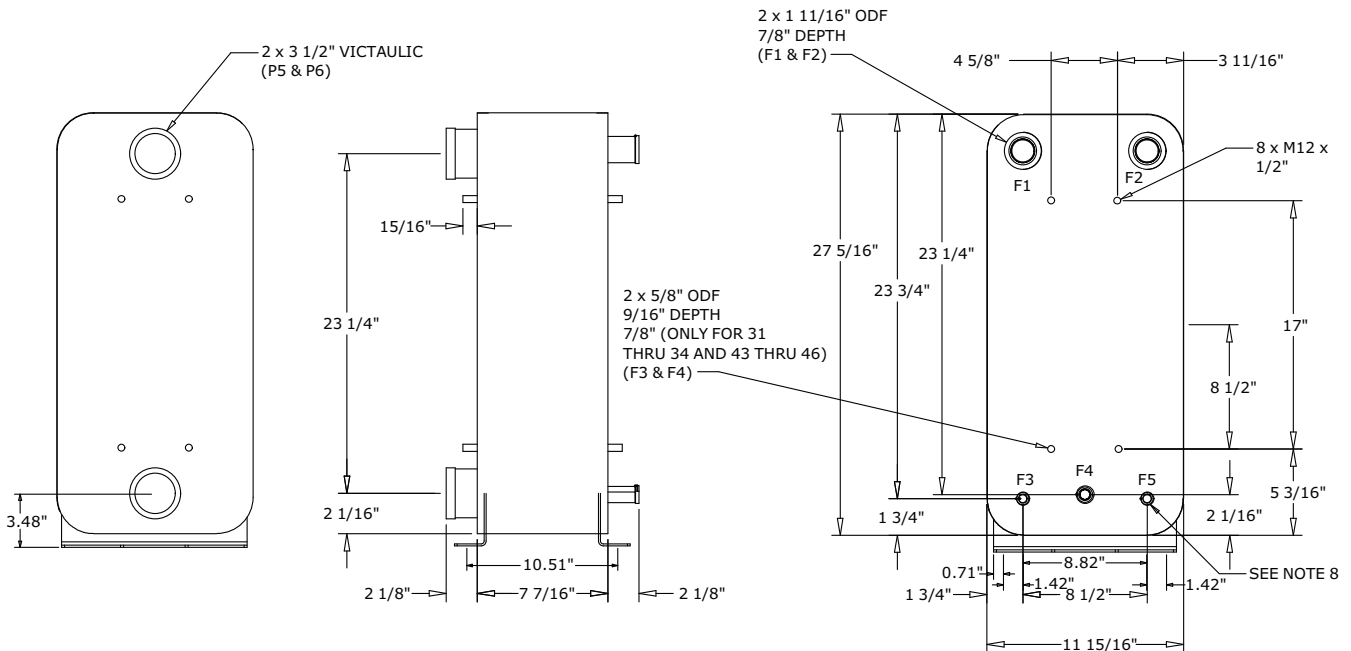

50 TON BRAZED PLATE HEAT EXCHANGER

ACCESSORY DRAWING

Figure 28. Evaporator chiller — 60 ton

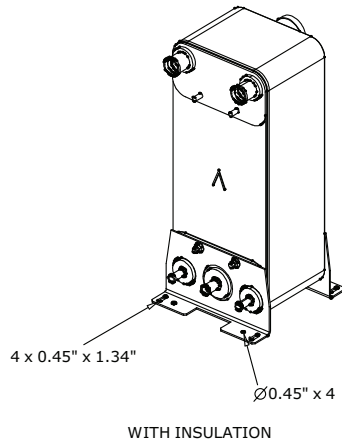

NOTES:

1. THIS HEAT EXCHANGER IS INTENDED FOR INDOOR INSTALLATION ONLY
2. HEAT EXCHANGER MOUNTING LEGS ARE INSTALLED AT JOB SITE WITH SUPPLIED FASTENERS
3. INSULATION SHOULD BE INSTALLED AFTER INSTALLING LEGS & REFRIGERANT TUBING, OR MUST BE ADEQUATELY SHIELDED AGAINST HEAT WHEN BRAZING REFRIGERANT LINES
4. INSTALL INSULATION SIDE PIECES FIRST THEN WRAPPER (MAY REQUIRE TRIMMING)
5. USE VINYL TAPE (FIELD SUPPLIED) TO SEAL INSULATION AFTER INSTALLATION
6. WATER CONNECTIONS ARE GROOVED (VICTAULIC)
7. REFRIGERANT CONNECTIONS ARE STAINLESS STEEL AND REQUIRE SPECIAL BRAZE MATERIALS. SEE IOM BRAZE PROCEDURE.
8. 1/2" - 14 NPT F5 CONNECTION SUPPLIED ON EXT'S 13 THRU 24 AND 37 THRU 48 ONLY.

BRAZED PLATE HEAT EXCHANGER REMOTE CHILLER EVAPORATOR OPTION

OPTION INCLUDES:

- 1 - BRAZED PLATE HEAT EXCHANGER - SHIPS SEPARATE FROM CONDENSING UNIT
- 1 - INSTALLATION KIT, TO INCLUDE:
 - 2 - MOUNTING BRACKETS
 - 1 - INSULATION KIT
 - 1 - MOUNTING BRACKET & INSULATION KIT INSTALLATION INSTRUCTIONS
- 1 - WATER CONNECTION KIT WITH PIPING STUBS, Y CONNECTOR, STRAINER, VICTAULIC CONNECTIONS WITH GASKETS, WATER FLOW SWITCH
- 1 - WATER CONNECTION KIT INSTALLATION INSTRUCTIONS

INSTALLATION ADDITIONALLY REQUIRES:

- EVP REMOTE PANEL WITH LEAVING WATER TEMPERATURE SENSOR, FREEZE-STAT, AND INSTALLATION INSTRUCTIONS
- 4 - FIELD PROVIDED 7/16" BOLTS FOR SECURING BRAZED PLATE HEAT EXCHANGER TO PERMANENT MOUNTING SURFACE
- 2 - FIELD PROVIDED 1/2" - 14 NPTE PLUGS, STAINLESS STEEL OR PVC
- FIELD PROVIDED TEFLON TAPE FOR SEALING 1/2" PIPE PLUGS
- FIELD PROVIDED WATER STRAINER PLUG OR BLOW DOWN VALVE
- FIELD PROVIDED TEE FOR INSTALLING WATER FLOW SWITCH
- FIELD PROVIDED 2" VINYL TAPE FOR SEALING INSULATION SEAMS

SEE IOM FOR INSTALLATION DETAIL

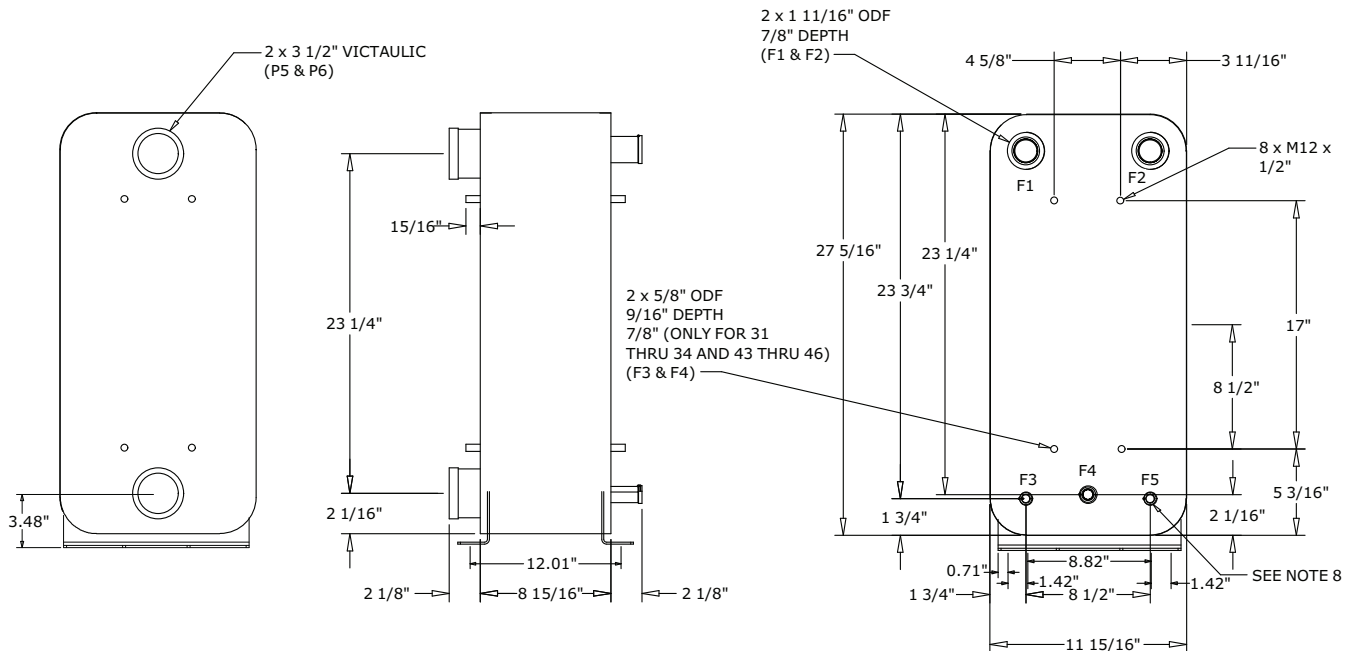

60 TON BRAZED PLATE HEAT EXCHANGER

ACCESSORY DRAWING



Dimensions and Weights

Figure 29. Evaporator chiller — 80 ton

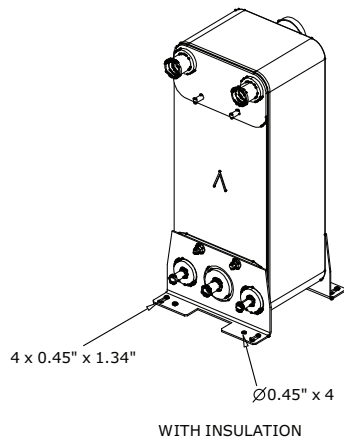

NOTES:

1. THIS HEAT EXCHANGER IS INTENDED FOR INDOOR INSTALLATION ONLY
2. HEAT EXCHANGER MOUNTING LEGS ARE INSTALLED AT JOB SITE WITH SUPPLIED FASTENERS
3. INSULATION SHOULD BE INSTALLED AFTER INSTALLING LEGS & REFRIGERANT TUBING, OR MUST BE ADEQUATELY SHIELDED AGAINST HEAT WHEN BRAZING REFRIGERANT LINES
4. INSTALL INSULATION SIDE PIECES FIRST THEN WRAPPER (MAY REQUIRE TRIMMING)
5. USE VINYL TAPE (FIELD SUPPLIED) TO SEAL INSULATION AFTER INSTALLATION
6. WATER CONNECTIONS ARE GROOVED (VICTAULIC)
7. REFRIGERANT CONNECTIONS ARE STAINLESS STEEL AND REQUIRE SPECIAL BRAZE MATERIALS. SEE IOM BRAZE PROCEDURE.
8. 1/2" - 14 NPT F5 CONNECTION SUPPLIED ON EXT'S 13 THRU 24 AND 37 THRU 48 ONLY.

BRAZED PLATE HEAT EXCHANGER REMOTE CHILLER EVAPORATOR OPTION

OPTION INCLUDES:

- 1 - BRAZED PLATE HEAT EXCHANGER - SHIPS SEPARATE FROM CONDENSING UNIT
- 1 - INSTALLATION KIT, TO INCLUDE:
 - 2 - MOUNTING BRACKETS
 - 1 - INSULATION KIT
 - 1 - MOUNTING BRACKET & INSULATION KIT INSTALLATION INSTRUCTIONS
- 1 - WATER CONNECTION KIT WITH PIPING STUBS, Y CONNECTOR, STRAINER, VICTAULIC CONNECTIONS WITH GASKETS, WATER FLOW SWITCH
- 1 - WATER CONNECTION KIT INSTALLATION INSTRUCTIONS

INSTALLATION ADDITIONALLY REQUIRES:

- EVP REMOTE PANEL WITH LEAVING WATER TEMPERATURE SENSOR, FREEZE-STAT, AND INSTALLATION INSTRUCTIONS
- 4 - FIELD PROVIDED 7/16" BOLTS FOR SECURING BRAZED PLATE HEAT EXCHANGER TO PERMANENT MOUNTING SURFACE
- 2 - FIELD PROVIDED 1/2" - 14 NPTE PLUGS, STAINLESS STEEL OR PVC
- FIELD PROVIDED TEFLON TAPE FOR SEALING 1/2" PIPE PLUGS
- FIELD PROVIDED WATER STRAINER PLUG OR BLOW DOWN VALVE
- FIELD PROVIDED TEE FOR INSTALLING WATER FLOW SWITCH
- FIELD PROVIDED 2" VINYL TAPE FOR SEALING INSULATION SEAMS

SEE IOM FOR INSTALLATION DETAIL

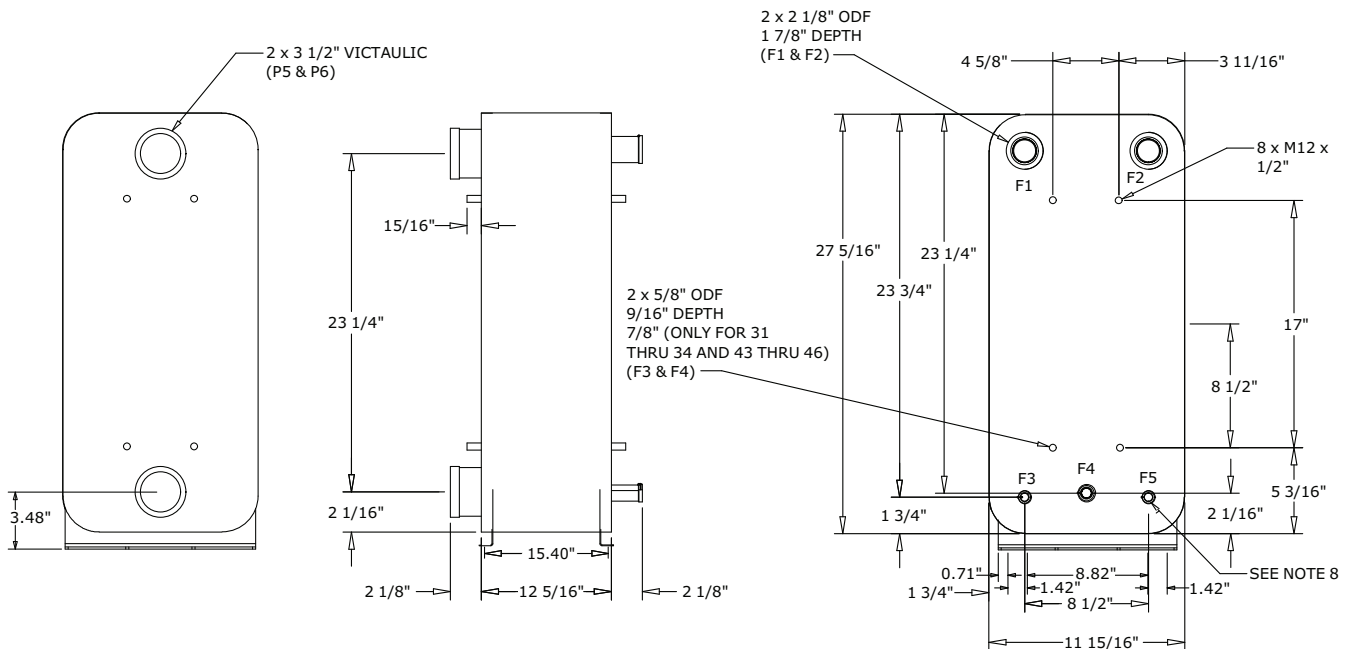

80 TON BRAZED PLATE HEAT EXCHANGER

ACCESSORY DRAWING



Dimensions and Weights

Figure 31. Evaporator chiller — 120 ton

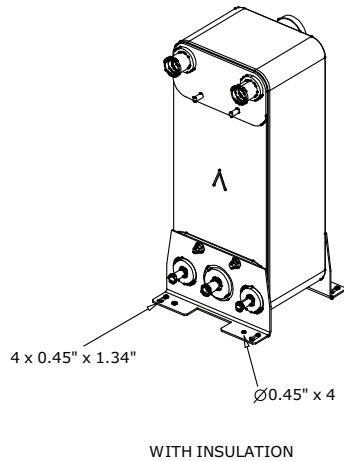

NOTES:

1. THIS HEAT EXCHANGER IS INTENDED FOR INDOOR INSTALLATION ONLY
2. HEAT EXCHANGER MOUNTING LEGS ARE INSTALLED AT JOB SITE WITH SUPPLIED FASTENERS
3. INSULATION SHOULD BE INSTALLED AFTER INSTALLING LEGS & REFRIGERANT TUBING, OR MUST BE ADEQUATELY SHIELDED AGAINST HEAT WHEN BRAZING REFRIGERANT LINES
4. INSTALL INSULATION SIDE PIECES FIRST THEN WRAPPER (MAY REQUIRE TRIMMING)
5. USE VINYL TAPE (FIELD SUPPLIED) TO SEAL INSULATION AFTER INSTALLATION
6. WATER CONNECTIONS ARE GROOVED (VICTAULIC)
7. REFRIGERANT CONNECTIONS ARE STAINLESS STEEL AND REQUIRE SPECIAL BRAZE MATERIALS. SEE IOM BRAZE PROCEDURE.
8. 1/2" - 14 NPT F5 CONNECTION SUPPLIED ON EXT'S 13 THRU 24 AND 37 THRU 48 ONLY.

BRAZED PLATE HEAT EXCHANGER REMOTE CHILLER EVAPORATOR OPTION

OPTION INCLUDES:

- 1 - BRAZED PLATE HEAT EXCHANGER - SHIPS SEPARATE FROM CONDENSING UNIT
- 1 - INSTALLATION KIT, TO INCLUDE:
 - 2 - MOUNTING BRACKETS
 - 1 - INSULATION KIT
 - 1 - MOUNTING BRACKET & INSULATION KIT INSTALLATION INSTRUCTIONS
- 1 - WATER CONNECTION KIT WITH PIPING STUBS, Y CONNECTOR, STRAINER, VICTAULIC CONNECTIONS WITH GASKETS, WATER FLOW SWITCH
- 1 - WATER CONNECTION KIT INSTALLATION INSTRUCTIONS

INSTALLATION ADDITIONALLY REQUIRES:

- EVP REMOTE PANEL WITH LEAVING WATER TEMPERATURE SENSOR, FREEZE-STAT, AND INSTALLATION INSTRUCTIONS
- 4 - FIELD PROVIDED 7/16" BOLTS FOR SECURING BRAZED PLATE HEAT EXCHANGER TO PERMANENT MOUNTING SURFACE
- 2 - FIELD PROVIDED 1/2" - 14 NPTE PLUGS, STAINLESS STEEL OR PVC
- FIELD PROVIDED TEFLON TAPE FOR SEALING 1/2" PIPE PLUGS
- FIELD PROVIDED WATER STRAINER PLUG OR BLOW DOWN VALVE
- FIELD PROVIDED TEE FOR INSTALLING WATER FLOW SWITCH
- FIELD PROVIDED 2" VINYL TAPE FOR SEALING INSULATION SEAMS

SEE IOM FOR INSTALLATION DETAIL

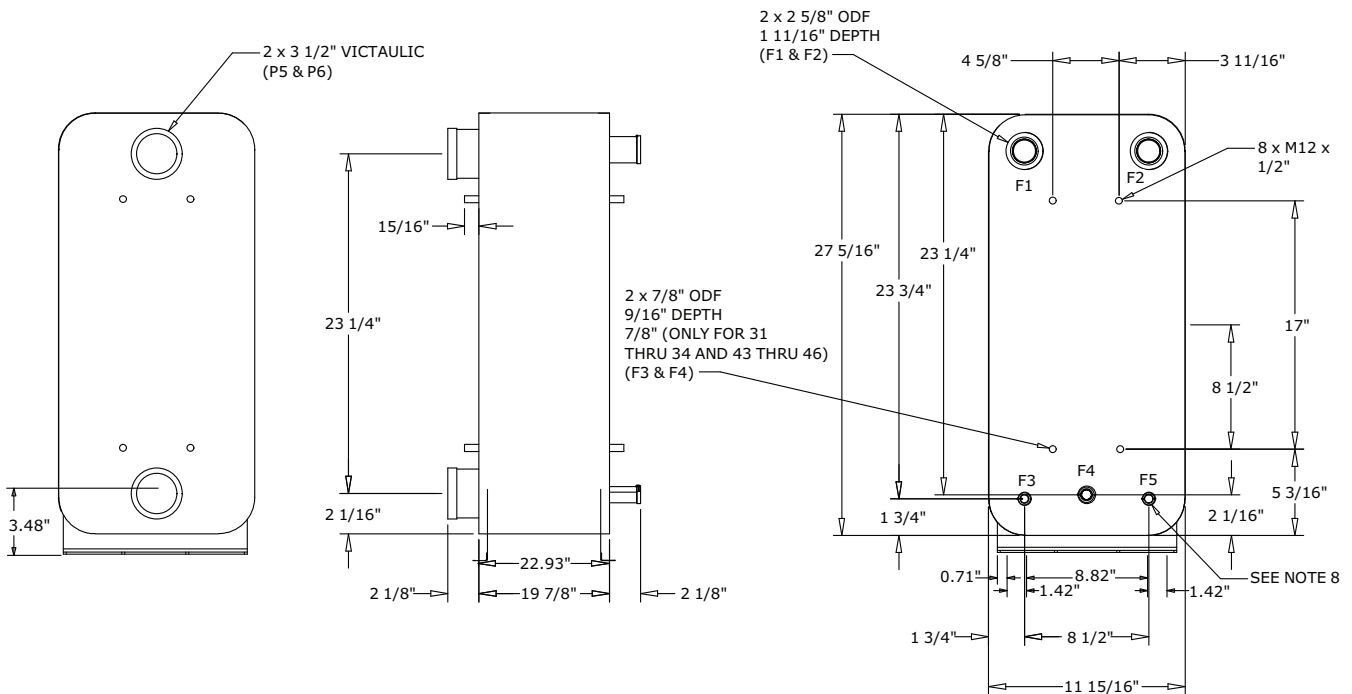

120 TON BRAZED PLATE HEAT EXCHANGER

ACCESSORY DRAWING

Unit Weights

Table 4. IntelliCore condensing unit weights

Unit Size (tons)	Operating Weights (lb) – R-410A	Operating Weights (lb) – R-454B
20	1783	1762
25	1843	1810
30	1875	1989
40	3028	3040
50	3380	3380
60	3355	3375
80	5129	5129
100	5811	5811
120	6310	6310

Table 5. EVP remote chiller weights

Unit Size (tons)	Weights (lbs)			
	Shipping		Operating	
	R-410A	R-454B	R-410A	R-454B
20	54	54	67	67
25	86	86	105	105
30	116	112	144	140
40	92	124	134	176
50	138	138	207	207
60	160	160	245	245
80	212	212	332	332
100	298	298	475	475
120	327	327	524	524



Installation Mechanical

Location Requirements

Isolation

To minimize unit sound and vibration transmission, one of the following installation methods should be used:

- Install the unit directly on an isolated (detached) concrete pad or on isolated concrete footings located at each unit load point. OR
- Install the optional neoprene or spring isolators at each mounting location. See “Unit Isolation,” p. 51.

Foundation

Ground Level Installation

- If the unit is installed at ground level, elevate it above the snow line.
- Provide concrete footings at each support location or a slab foundation for support.
- See “Unit Weights,” p. 47 in Dimensions and Weights chapter for the unit operating weights.
- See “Unit Isolation,” p. 51 for mounting locations and point loading weights when constructing the footing foundation.
- Anchor the unit to the footings or slab using hold down bolts or isolators.
- Isolators should be installed to minimize the transmission of vibrations into the building. See “Unit Isolation,” p. 51.

Rooftop Applications

For rooftop applications, ensure the roof is strong enough to support the unit. See Weights table in Dimensions and Weights chapter for the unit operating weights.

Anchor the unit to the roof with hold-down bolts or isolators. Follow the instructions in “Unit Isolation,” p. 51 for proper isolator placement and installation.

Check with a roofing contractor for proper waterproofing procedures.

Leveling the Unit

Before tightening the mounting bolts, level the unit carefully. Use the unit base rail as a reference. Level the unit to within 1/4 inch over its entire length. Use shims if non-adjustable isolators (neoprene) are used.

If adjustable isolators (spring) are used, ensure that the proper isolator housing clearance is maintained while leveling the unit. Isolators are identified by color and/or an isolator part number. Shims under the isolators may be required if the unit cannot be leveled using the isolator leveling bolt.

Rigging and Lifting

⚠ WARNING

Heavy Object!

Failure to follow instructions below could result in unit dropping which could result in death or serious injury, and equipment or property-only damage. Ensure that all the lifting equipment used is properly rated for the weight of the unit being lifted. Each of the cables (chains or slings), hooks, and shackles used to lift the unit must be capable of supporting the entire weight of the unit. Lifting cables (chains or slings) may not be of the same length. Adjust as necessary for even unit lift.

⚠ WARNING

Improper Unit Lift!

Failure to properly lift unit in a LEVEL position could result in unit dropping and possibly crushing operator/technician which could result in death or serious injury, and equipment or property-only damage. Test lift unit approximately 24 inches (61 cm) to verify proper center of gravity lift point. To avoid dropping of unit, reposition lifting point if unit is not level.

See “Unit Weights,” p. 47 in Dimensions and Weights chapter for unit weights. See Table 6, p. 50 for center-of-gravity information.

1. Rig condensing unit as shown in Figure 32, p. 49 and Figure 33, p. 49. Attach adequate strength lifting slings to all four lifting brackets. Do not use cables, chains, or slings except as shown.
2. Install spreader bars as shown in Figure 32, p. 49 to protect the unit and to facilitate a uniform lift. Minimum distance between lifting hook and top of unit is 7 feet.
3. Test-lift the unit to ensure it is properly rigged and balanced. Make any necessary rigging adjustments.
4. Lift the unit and position into place.

Figure 32. Rigging and center-of-gravity data

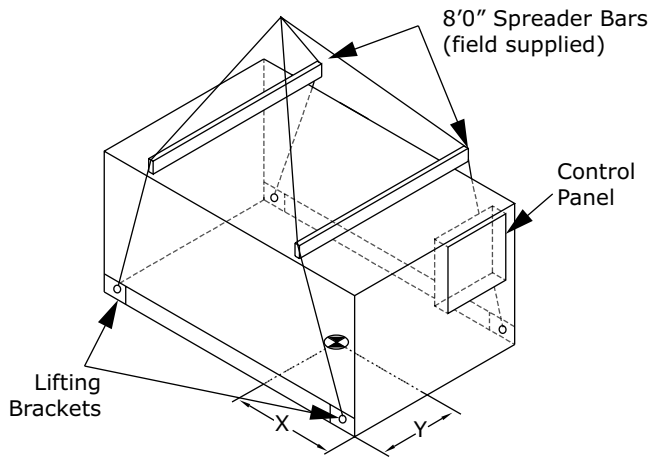

Note: See lifting bracket location figure for more detail.

Figure 33. Lifting bracket locations

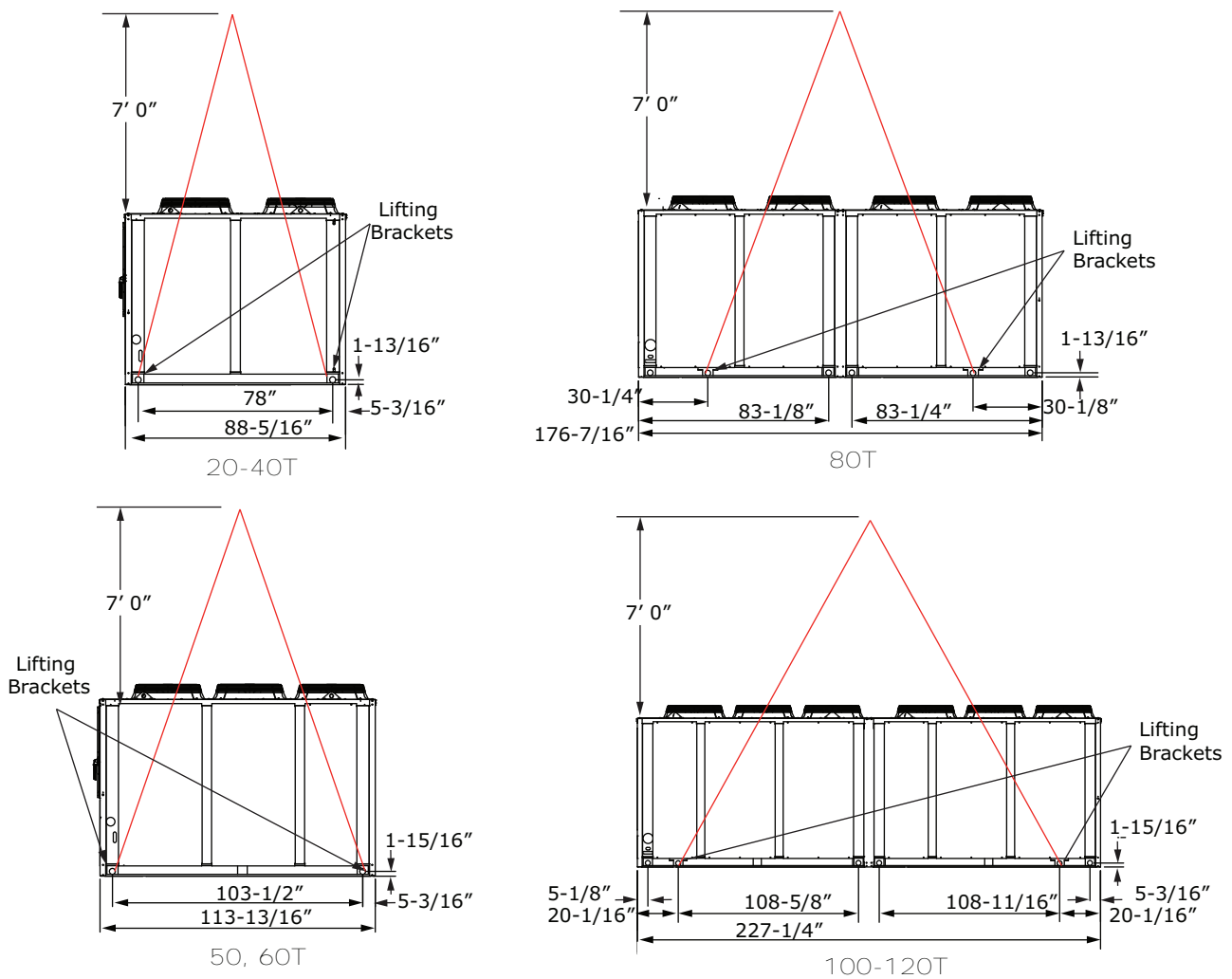

Table 6. RAUK center-of-gravity

Tons	CG Locations	
	X	Y
20	38.0	33.5
25	37.9	33.3
30	36.0	34.2
40	41.3	46.6
50	50.3	46.5
60	50.1	46.5
80	85.8	56.4
100	110.9	55.6
120	111.2	54.8

Unit Mounting

Figure 34. Mounting location

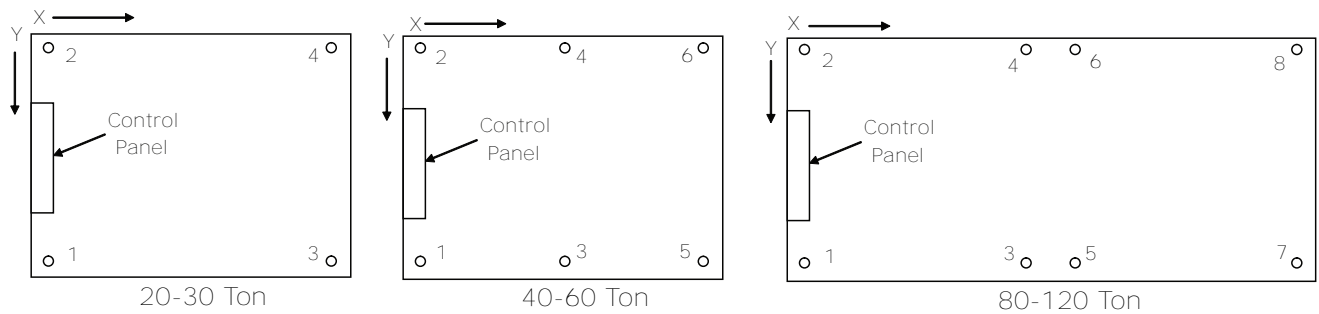

Table 7. Isolator mounting locations (in)

Unit Size (Tons)		Mounting Location							
		1	2	3	4	5	6	7	8
20/25/30	X	8.00	8.00	80.125	80.125	-	-	-	-
	Y	58.75	1.25	58.75	1.25	-	-	-	-
40	X	8.00	8.00	44.125	44.125	80.25	80.25	-	-
	Y	87.125	1.25	87.125	1.25	87.125	1.25	-	-
50/60	X	8.00	8.00	56.875	56.875	105.75	105.75	-	-
	Y	87.125	1.25	87.125	1.25	87.125	1.25	-	-
80	X	8.00	8.00	80.125	80.125	108.125	108.125	168.25	168.25
	Y	87.125	1.25	87.125	1.25	87.125	1.25	87.125	1.25
100/120	X	8.00	8.00	105.625	105.625	121.625	121.625	219.25	219.25
	Y	87.125	1.25	87.125	1.25	87.125	1.25	87.125	1.25

Table 8. RAUK point loading weights (lbs)

Unit Size (Tons)	Mounting Location							
	1	2	3	4	5	6	7	8
20	567.6	461.3	419.7	313.4	-	-	-	-
25	580.9	478.0	427.0	324.1	-	-	-	-
30	680.7	535.2	459.3	313.8	-	-	-	-
40	594.3	536.8	535.4	477.9	476.5	419.1	-	-
50	707.2	647.5	593.2	533.5	479.1	419.5	-	-
60	708.6	649.1	592.2	532.8	475.9	416.4	-	-
80	909.4	544.7	834.8	470.1	805.9	441.2	743.8	379.1
100	956.6	571.5	921.8	536.7	916.1	531.0	881.3	496.1
120	1018.9	630.6	985.6	597.3	980.2	591.9	946.9	558.6

Unit Isolation

Neoprene Isolators (20 to 60 Ton units)

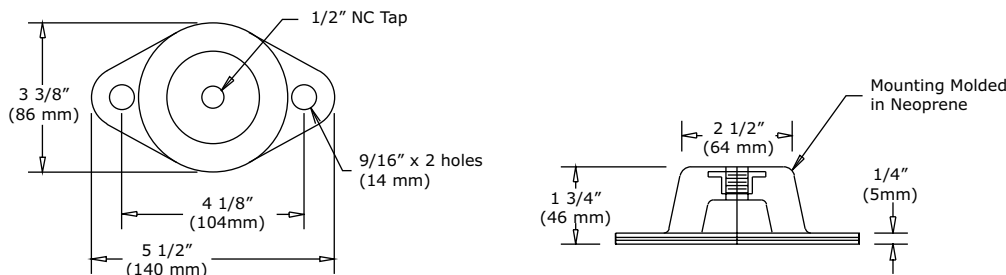
Figure 35. Neoprene isolators (20 to 60 ton units only)

Table 9. RAUK neoprene isolator selection (20 to 60 ton units only)

Unit Size (Tons)	Mounting Location					
	1	2	3	4	5	6
20	R-3-GREEN	R-3-RED	R-3-RED	R-3-RED	-	-
25	R-3-GREEN	R-3-RED	R-3-RED	R-3-RED	-	-
30	R-3-GREEN	R-3-GREEN	R-3-RED	R-3-RED	-	-
40	R-3-GREEN	R-3-GREEN	R-3-GREEN	R-3-RED	R-3-RED	R-3-RED
50	R-3-GREEN	R-3-GREEN	R-3-GREEN	R-3-GREEN	R-3-RED	R-3-RED
60	R-3-GREEN	R-3-GREEN	R-3-GREEN	R-3-GREEN	R-3-RED	R-3-RED

⚠ WARNING

Heavy Object!

Failure to follow instructions could result in death or serious injury.

Use solid type blocks, such as 4 X 4 inch wood blocks or similar material, to prevent collapsing. Keep hands and other body limbs clear of elevated base rail while installing isolators.

Install the neoprene isolators at each unit mounting (load) point, using the following procedure:

1. Elevate the unit (one side at a time) to allow access to the base rail mounting holes.
2. Align the mounting holes in the base rail of the unit with the holes in the top of the appropriate isolator.
3. Install a 1/2-inch NC bolt (field supplied) through the base rail of the unit into the threaded bolt hole of the isolator. Position the isolator to allow access to the mounting holes in the base of the isolator, then tighten securely.
4. Lower the unit and isolator onto the mounting surface. The maximum isolator deflection should be approximately 1/4-inch.

5. Secure the isolator to the mounting surface using the base holes in the isolator.
6. Level the unit carefully. See “Leveling the Unit,” p. 48.
7. After the unit is level, tighten the isolator base mounting bolts to secure them to the mounting surface.

Spring Isolators (20 to 120 Ton units)

Figure 36. Spring isolators

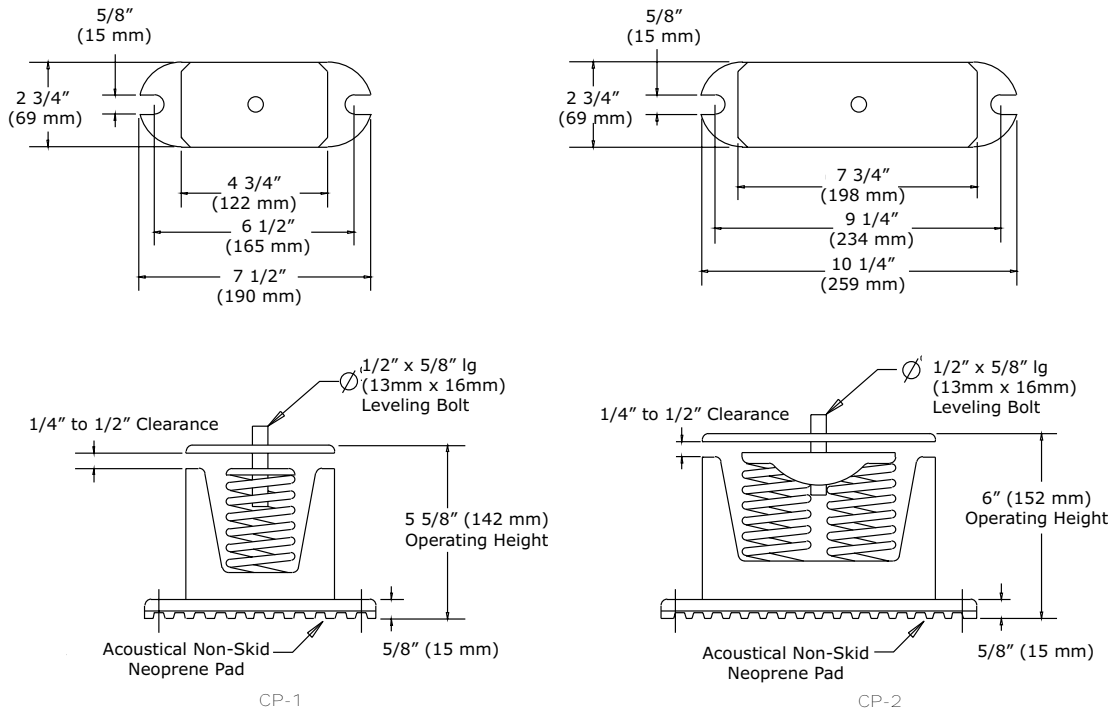

Table 10. RAUK spring isolator selection

Unit Size (Tons)	Mounting Location							
	1	2	3	4	5	6	7	8
20	CP-1D-675	CP-1D-510	CP-1D-510	CP-1D-340	-	-	-	-
25	CP-1D-675	CP-1D-510	CP-1D-510	CP-1D-340	-	-	-	-
30	CP-1D-900	CP-1D-675	CP-1D-510	CP-1D-340	-	-	-	-
40	CP-1D-675	CP-1D-675	CP-1D-675	CP-1D-510	CP-1D-510	CP-1D-510	-	-
50	CP-1D-900	CP-1D-900	CP-1D-675	CP-1D-675	CP-1D-510	CP-1D-510	-	-
60	CP-1D-900	CP-1D-900	CP-1D-675	CP-1D-675	CP-1D-510	CP-1D-510	-	-
80	C2P-1D-1020	CP-1D-675	CP-1D-900	CP-1D-510	CP-1D-900	CP-1D-510	CP-1D-900	CP-1D-510
100	C2P-1D-1020	CP-1D-675	C2P-1D-1020	CP-1D-675	C2P-1D-1020	CP-1D-675	CP-1D-900	CP-1D-510
120	CP-1D-1200	CP-1D-675	C2P-1D-1020	CP-1D-675	C2P-1D-1020	CP-1D-675	C2P-1D-1020	CP-1D-675

⚠ WARNING

Heavy Object!

Failure to follow instructions could result in death or serious injury.

Use solid type blocks, such as 4 X 4 inch wood blocks or similar material, to prevent collapsing. Keep hands and other body limbs clear of elevated base rail while installing isolators.

- Install the spring isolators at each unit mounting (load) point, using the following procedure:
1. Elevate the unit (one side at a time) to allow access to the base rail mounting holes.
 2. Align the mounting holes in the base rail of the unit with the positioning pin in the top of the appropriate isolator.
 3. Position the isolator to allow access to the mounting holes in the base of the isolator.

4. Lower the unit onto the isolator. The positioning pin on the isolator must engage into the hole of the base rail. The clearance between the upper and lower isolator housings should be approximately 1/4 to 1/2-inch. A clearance greater than 1/2-inch indicates that shims are required to level the unit. See “[Leveling the Unit](#),” p. 48.
5. Make minor clearance adjustments by turning the isolator leveling bolt clockwise to increase the clearance and counterclockwise to decrease the clearance. If proper isolator clearance cannot be obtained by turning the leveling bolt, level the isolators themselves. A 1/4-inch variance in elevation is acceptable.
6. Secure the isolator to the mounting surface using the base holes in the isolator.
7. After unit is level, tighten isolator base mounting bolts to secure them to the mounting surface.

Installation

General Unit Requirements

NOTICE

Equipment Damage!

Failure to follow instructions below could result in equipment damage.

Apply the supplied flammable-gas labels to the unit, after the unit is installed and charged, fully covering all factory-installed non-flammable-gas labels.

The checklist listed below is a summary of the steps required to successfully install a commercial air cooled condenser. This checklist is intended to acquaint the installing personnel with what is required in the installation process. It does not replace the detailed instruction called out in the applicable sections of this manual.

- Install Froststat on the suction line. See [Figure 37](#), p. 54.
- Verify that the power supply complies with the unit nameplate specifications.
- Check the unit for shipping damage and material shortage. If damage or shortage is found, file a freight claim and notify Trane office.

- Verify installation location of the unit will provide the required clearance for proper operation.
- Install appropriate isolators, if required.
- Install discharge temperature sensor in the leaving evaporator air stream.

Refrigerant Piping Requirements

Note: See “[Refrigerant Piping Components](#),” p. 53 and “[Refrigerant Piping](#),” p. 57 for recommended line components and guidelines.

- Install properly sized liquid line(s) between the liquid line connections on the unit and the evaporator.
- Install a properly sized liquid line isolation solenoid valve in each liquid line.
- Install refrigerant rated shut-off valves in the liquid line (s) to isolate the filter drier(s) for service.
- Install a properly sized filter drier in each liquid line.
- Install properly sized suction line(s) between the suction line connections on the unit and the evaporator.
- Install a properly sized filter in each suction line.
- Install properly sized hot gas bypass line(s) between the hot gas bypass connections on the unit and the evaporator.
- Insulate the suction line.
- See “[Installation Mechanical — EVP](#),” p. 63 for chiller installation instructions.
- Leak test the system per “[Leak Testing Procedure](#),” p. 61.

Refrigerant Piping Components

For recommended components, see *Tube Size and Component Selection IntelliCore™ Split Systems (20 to 120 Tons) R-454B Refrigerant Microchannel Condensers Application Guide (SS-APG018*-EN)* for R-454B and *Tube Size and Component Selection RAUJ Split Systems (20 to 120 Tons) R-410A Refrigerant Microchannel Condensers Application Guide (SS-APG012*-EN)* for R-410A.

Figure 37. Typical placement of split system piping components

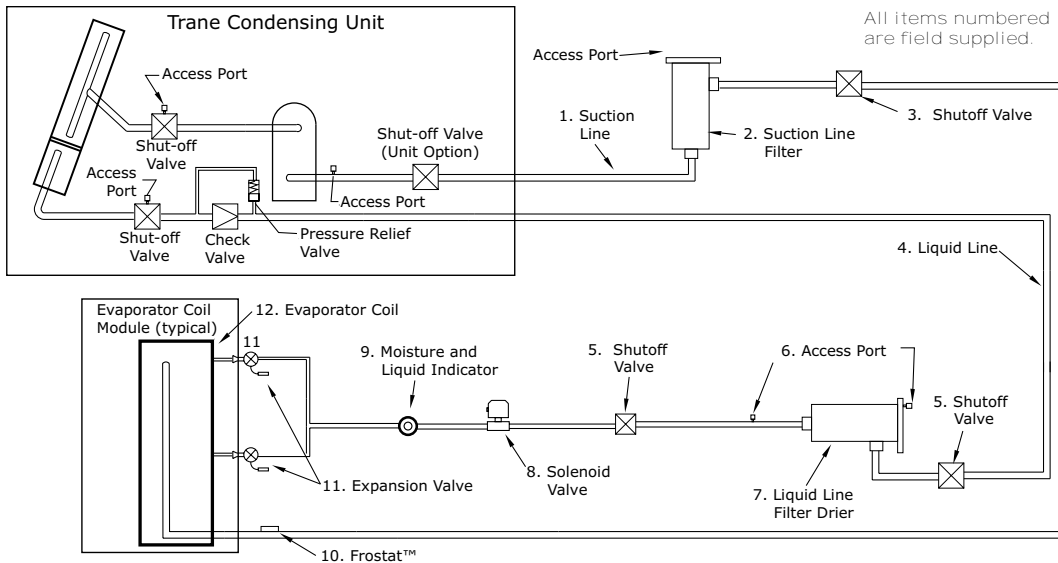

Table 11. Component number descriptions

Component	Description
1	Interconnecting suction line tubing
2	Suction line filter
3	Shutoff valves - Manual ball valves
4	Interconnecting liquid line tubing. If risers exceed 10 feet, Trane must review the application
5	Shutoff valves - Manual ball valves
6	Access ports
7	Liquid line filter drier
8	Liquid line solenoid valve
9	Moisture and liquid indicator
10	Froststat™ (Required for coil freeze protection)
11	Expansion valve (One expansion valve for each coil distributor)
12	Evaporator coil

Suction Line Components

Suction line refrigerant components necessary for field installation in the suction line are a filter (Core Type), access valves (ports), Froststat™ control for coil frost protection, and ball shutoff valves. See [Figure 37, p. 54](#) for placement location.

Suction Filter/Filter Drier (Field Supplied)

Install the filter in the suction line upstream of the compressors. To prevent oil accumulation, suction filters should be installed vertical with the outlet at the bottom or no more than 45° degree from vertical.

Ball Shutoff Valves

The ball shutoff valve allows for isolation of the Filter/Filter Drier for easier core replacement.

Two ball shutoff valves equal to the OD Tubing size for suction line are required.

Access Valves (Ports)

The access ports in the suction line allow the operating suction pressure to be checked across the suction line filter. These ports are usually a Schrader valve with core.

Froststat Coil Frost Protection

Froststat™ Protection uses a bi-metallic disc thermostat switch that opens/closes a set of contacts when the temperature gets to a certain level. The Froststat control bulb is mechanically attached to the suction line near the evaporator and wired to the unit control panel. See unit schematics for details.

Liquid Line Components

The required liquid line refrigerant components include a filter drier (Core Type), access valve(s) or (ports), solenoid valve(s), moisture indicating sight glass, expansion valve (s), and ball shutoff valve(s). See [Figure 37, p. 54](#) for placement location.

Liquid Line Filter/Filter Drier (Field Supplied)

Install the filter drier in the liquid line as close as possible to the expansion valve. Locate them upstream of the moisture indicator and solenoid valve (if applicable).

Liquid Line Moisture Indicator Sight Glass

To aid in troubleshooting, install a moisture indicator sight glass in the liquid line near the evaporator, downstream of the solenoid valve prior to any branch takeoffs to the expansion valve. The sight glass should not be used to determine adequate refrigerant charge. Liquid temperature

and discharge pressure measurements are required to determine the proper charge. Note that under some conditions, charging until the sight glass is solid liquid will overcharge the system and reduce compressor reliability. See “Compressor Start-Up (All Systems),” p. 101 for proper system charging.

Liquid Line Solenoid Valves

NOTICE

Equipment Damage!

Do not use solenoid valve as a pumpdown device as it could result in equipment damage.

Liquid line isolation solenoid valves (one per refrigeration circuit) are required for refrigerant migration control into

evaporator during **Off** cycle and should be connected as illustrated in applicable unit schematics.

Thermostatic Expansion Valve (TXV)

Trane recommends a balance-ported externally equalized valve in order to maintain satisfactory superheat control down to lower valve loading conditions and to compensate for pressure drops between the expansion valve and superheat control point (evaporator refrigerant outlet).

In order to get proper refrigerant distribution into the coil, an expansion valve is required for each coil distributor. See tables below for valve selection.

Table 12. R-410A expansion valve selection, any BPHE all fin and tube OD coils (0% bleed)

Min Tonnage	Max Tonnage	Selection ^(a)	Alternate ^(a)
1.5	2.0	BBIZE-1-1/2-GA	ERZE-1-1/2-GA
2.0	3.0	BBIZE-2-GA	ERZE-2-GA
2.5	4.0	BBIZE-3-GA	ERZE-3-GA
3.5	5.5	BBIZE-4-GA	ERZE-4-GA
4.5	6.5	BBIZE-5-GA	ERZE-5-GA
5.5	7.5	BBIZE-6-GA	ERZE-6-GA
6.5	10.5	BBIZE-8-GA	ERZE-8-GA
8.5	13.5	BBIZE-12-1/2-GA	ERZE-12-1/2-GA
11.0	16.5	BBIZE-15-GA	ERZE-15-GA
13.0	22.0	OZE-20-GA	—
17.0	26.0	OZE-25-GA	—
20.5	39.0	OZE-35-GA	—
30.5	59.0	OZE-50-GA	—
45.5	70.0	OZE-60-GA	—

^(a) Valve part numbers with “-ZGA” in place of “-GA”, may be used interchangeably.

Table 13. R-454B expansion valve selection, any BPHE

Min Tonnage	Max Tonnage	Manufacturer	Selection ^(a)	Alternate
13.0	22.0	Sporlan	OYE 20-CP	VAL21152
17.0	26.0	Sporlan	OYE 25-CP	VAL21153
20.5	39.0	Sporlan	OYE 35-CP	VAL21805
30.5	59.0	Sporlan	OYE 55-CP	VAL21806

^(a) Valve part numbers with “-ZGA” in place of “-GA”, may be used interchangeably.

Table 14. R-410A expansion valve selection, 20 to 60 ton MCHE (30% bleed)

Min Tonnage	Max Tonnage	Manufacturer	Selection ^(a)	Trane Part
2.0	3.0	Sporlan	ERZE-1-1/2-ZGA (BP/15)	VAL10487
2.5	3.5	Sporlan	ERZE-2-ZGA (BP/30)	VAL10488
3.5	5.0	Sporlan	ERZE-3-ZGA (BP/30)	VAL10489
4.5	7.0	Sporlan	ERZE-4-ZGA (BP/30)	VAL10490
6.0	8.5	Sporlan	ERZE-5-ZGA (BP/30)	VAL10491



Installation Mechanical

Table 14. R-410A expansion valve selection, 20 to 60 ton MCHE (30% bleed) (continued)

Min Tonnage	Max Tonnage	Manufacturer	Selection ^(a)	Trane Part
7.0	10.0	Sporlan	ERZE-6-ZGA (BP/30)	VAL10492
8.0	13.5	Sporlan	ERZE-8-ZGA (BP/30)	VAL10493
11.0	17.5	Sporlan	ERZE-12-1/2-ZGA (BP/30)	VAL10494
14.0	21.5	Sporlan	ERZE-15-ZGA (BP/30)	VAL10495
17.0	28.5	Sporlan	OZE-20-ZGA (BP/30)	VAL10496
22.0	30.0	Sporlan	OZE-25-ZGA (BP/30)	VAL10497

^(a) Valve part numbers with "-ZGA" in place of "-GA", may be used interchangeably.

Table 15. R-454B expansion valve selection, 20 to 60 ton MCHE (30% bleed)

Min Tonnage	Max Tonnage	Manufacturer	Selection ^(a)	Trane Part
2.5	3.0	Sporlan	BBIYE 2.5-CP (BP/30)	VAL21648
3.5	5.0	Sporlan	BBIYE 3-CP (BP/30)	VAL21649
4.5	7.0	Sporlan	BBIYE 4.5-CP (BP/30)	VAL21650
6.0	8.5	Sporlan	BBIYE 6-CP (BP/30)	VAL21651
7.0	10.0	Sporlan	BBIYE 7-CP (BP/30)	VAL21652
8.0	13.5	Sporlan	BBIYE 8.5-CP (BP/30)	VAL21653
11.0	17.5	Sporlan	BBIYE 11.5-CP (BP/30)	VAL21654
12.5	19.0	Sporlan	BBIYE 15.5-CP (BP/30)	VAL21655
14.0	21.5	Sporlan	BBIYE 18-CP (BP/30)	VAL21656
17.0	28.5	Sporlan	OYE-20-CP (BP/30)	VAL21657
22.0	30.0	Sporlan	OYE-25-CP (BP/30)	VAL21658

^(a) Valve part numbers with "-ZGA" in place of "-GA", may be used interchangeably.

Table 16. R-410A expansion valve selection, 80 to 120 ton MCHE (15% bleed)

Min Tonnage	Max Tonnage	Manufacturer Selection ^(a)	Trane Part
2	2.5	Sporlan ERZE-1-1/2-ZGA (BP/15)	n/a
2.5	3	Sporlan ERZE-2-ZGA (BP/15)	n/a
3	4.5	Sporlan ERZE-3-ZGA (BP/15)	n/a
4	6	Sporlan ERZE-4-ZGA (BP/15)	n/a
5	7.5	Sporlan ERZE-5-ZGA (BP/15)	VAL10579
6	9	Sporlan ERZE-6-ZGA (BP/15)	VAL10580
7	12	Sporlan ERZE-8-ZGA (BP/15)	VAL10581
9.5	15.5	Sporlan ERZE-12-1/2-ZGA (BP/15)	VAL10582
12.5	19	Sporlan ERZE-15-ZGA (BP/15)	VAL10583
15	25	Sporlan OZE-20-ZGA (BP/15)	VAL10584
19.5	30	Sporlan OZE-25-ZGA (BP/15)	VAL10585
23.5	45	Sporlan OZE-35-ZGA (BP/15)	VAL10586
35	68	Sporlan OZE-50-ZGA (BP/15)	VAL10587
52.5	70	Sporlan OZE-60-ZGA (BP/15)	VAL10588

^(a) Valve part numbers with "-ZGA" in place of "-GA", may be used interchangeably.

Table 17. R-454B expansion valve selection, 80 to 120 ton MCHE (15% bleed)

Min Tonnage	Max Tonnage	Manufacturer	Selection ^(a)	Trane Part
2.5	3.0	Sporlan	BBIYE 2.5-CP (BP/15)	VAL21660
3.0	4.5	Sporlan	BBIYE 3-CP (BP/15)	VAL21661
4.0	6.0	Sporlan	BBIYE 4.5-CP (BP/15)	VAL21662
5.0	7.5	Sporlan	BBIYE 6-CP (BP/15)	VAL21663
6.0	9.0	Sporlan	BBIYE 7-CP (BP/15)	VAL21664
7.0	12.0	Sporlan	BBIYE 8.5-CP (BP/15)	VAL21665
9.5	15.5	Sporlan	BBIYE 11.5-CP (BP/15)	VAL21666
12.5	19.0	Sporlan	BBIYE 15.5-CP (BP/15)	VAL21667
14.0	21.5	Sporlan	BBIYE 18-CP (BP/15)	VAL21668
15.0	25.0	Sporlan	OYE-20-CP (BP/15)	VAL21669
19.5	30.0	Sporlan	OYE-25-CP (BP/15)	VAL21670
23.5	45.0	Sporlan	OYE-35-CP (BP/15)	VAL21671
35.0	68.0	Sporlan	OYE-55-CP (BP/15)	VAL21672

^(a) Valve part numbers with "-ZGA" in place of "-GA", may be used interchangeably.

TXV for Remote Chiller

See "Installation Mechanical — EVP," p. 63 for piping between TXV and remote chiller.

Ball Shutoff Valves

The ball shutoff valve allows for isolation of the filter/filter drier for easier core replacement.

Two ball shutoff valves equal to the OD tubing size for liquid line are required.

Access Valves (Ports)

The access ports in the liquid line allows the unit to be charged with liquid refrigerant and is used to determine sub-cooling.

Refrigerant Piping

NOTICE

Compressor Damage!

POE oil is hygroscopic – it absorbs water directly from the air. This water is nearly impossible to remove from the compressor oil and can result in compressor failures.

To prevent POE oil from absorbing water, the system should not remain open for longer than necessary. When open, dry nitrogen should flow through the piping. Only new oil containers should be used for service and maintenance. Always use the smallest container size required for the job requirements. Always leave the oil container tightly sealed until time of use. Do not reuse oil that has been opened.

Refrigerant piping must be properly sized and applied. These two factors have a very significant effect on both system performance and reliability.

Note: Use Type L refrigerant grade copper tubing only.

Refrigerant Piping should be sized and laid out according to the job plans and specifications. This should be done when the system components are selected.

Suction Line Piping

Proper suction line sizing is required to guarantee that oil is returned to the compressor throughout the operating system. Furthermore, the line must be sized so that the pressure drop does not excessively affect capacity or efficiency. To accomplish both, it may be necessary to have two sizes, one for horizontal run and vertical drops, and another for the vertical lifts.

For the correct pipe sizes, per your application, please see the latest version of *Tube Size and Component Selection IntelliCore™ Split Systems (20 to 120 Tons) R-454B Refrigerant Microchannel Condensers Application Guide (SS-APG018*-EN)* for R-454B and *Tube Size and Component Selection RAUJ Split Systems (20 to 120 Tons) R-410A Refrigerant Microchannel Condensers Application Guide (SS-APG012*-EN)* for R-410A.

- Do not use suction line traps.
- Do not use double risers.
- Avoid putting liquid lines underground.
- Route suction lines as short and direct as possible.
- Slope suction lines toward the evaporator ¼-inch to 1-inch for every 10 feet.
- Insulate the suction lines.
- The suction line filter should be as close to the compressor as possible.

Note: If suction riser exceeds 50 feet, Trane must review the application.

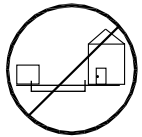

Liquid Line Piping

Oversized liquid lines reduce compressor reliability due to excess refrigerant in the system, and system operation becomes more charge critical due to liquid thermal expansion into the condenser at higher ambients. Conversely, liquid line OD needs to be big enough to allow for adequate subcooling entering the expansion valve at high load conditions.

For the correct pipe sizes, per your application, please see the latest version of *Tube Size and Component Selection IntelliCore™ Split Systems (20 to 120 Tons) R-454B Refrigerant Microchannel Condensers Application Guide (SS-APG018*-EN)* for R-454B and *Tube Size and Component Selection RAUJ Split Systems (20 to 120 Tons) R-410A Refrigerant Microchannel Condensers Application Guide (SS-APG012*-EN)* for R-410A.

The liquid line should have a slight slope in the direction of flow so that it can be routed with the suction line.

The unit has a liquid line check valve that prevents liquid refrigerant from flowing backward through the liquid line, filling the condenser, and overflowing to the compressor during the **Off** cycle. A relief valve is also installed to prevent the buildup of high pressure in the liquid line when the unit is off. For proper operation of the relief valve, the liquid line service valve should not be in the back seated position but cracked open so the relief valve (and the fan pressure switch) is open to the condenser. The line that connects the outlet of the 235 psig relief valve to the liquid line service valve must not be removed.

For more information, see *Tube Size and Component Selection IntelliCore™ Split Systems (20 to 120 Tons) R-*

454B Refrigerant Microchannel Condensers Application Guide (SS-APG018-EN)* for R-454B and *Tube Size and Component Selection RAUJ Split Systems (20 to 120 Tons) R-410A Refrigerant Microchannel Condensers Application Guide (SS-APG012*-EN)* for R-410A.

- Avoid putting liquid lines underground.
- Route liquid lines as short and direct as possible.
- Slope liquid lines away from the condensing unit 1-inch for every 10 feet.
- Only insulate liquid lines that pass through heated areas.
- Wire solenoid valves according to the unit schematics for proper operation.
- The liquid line filter drier should be as close to the solenoid valve as possible.

Note: If the liquid line riser exceeds 10 feet, see *Tube Size and Component Selection IntelliCore™ Split Systems (20 to 120 Tons) R-454B Refrigerant Microchannel Condensers Application Guide (SS-APG018*-EN)* for R-454B and *Tube Size and Component Selection RAUJ Split Systems (20 to 120 Tons) R-410A Refrigerant Microchannel Condensers Application Guide (SS-APG012*-EN)* for R-410A.

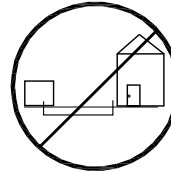

Typical Field-Installed Evaporator Piping: Dual-Circuit Examples

1. Install the TXV directly to the unit liquid connection.
2. Locate the TXV bulb midway between the 90 degrees bends on top of the suction line as illustrated in [Figure 38, p. 59](#) or [Figure 39, p. 59](#).
3. Secure bulb to suction line with two clamps provided by manufacturer and insulate bulb.
4. Install the Froststat™ according to instructions enclosed in the kit as close to evaporator as possible.

Note: All 20 to 60 ton units will require 30% bleed TXVs. All 80 to 120 ton units will require 15% bleed TXVs. This does not apply if they are connected to remote chiller evaporators (see [“Hot Gas Bypass for Commercial Comfort-Cooling Applications,” p. 59](#)).

Figure 38. Face-split

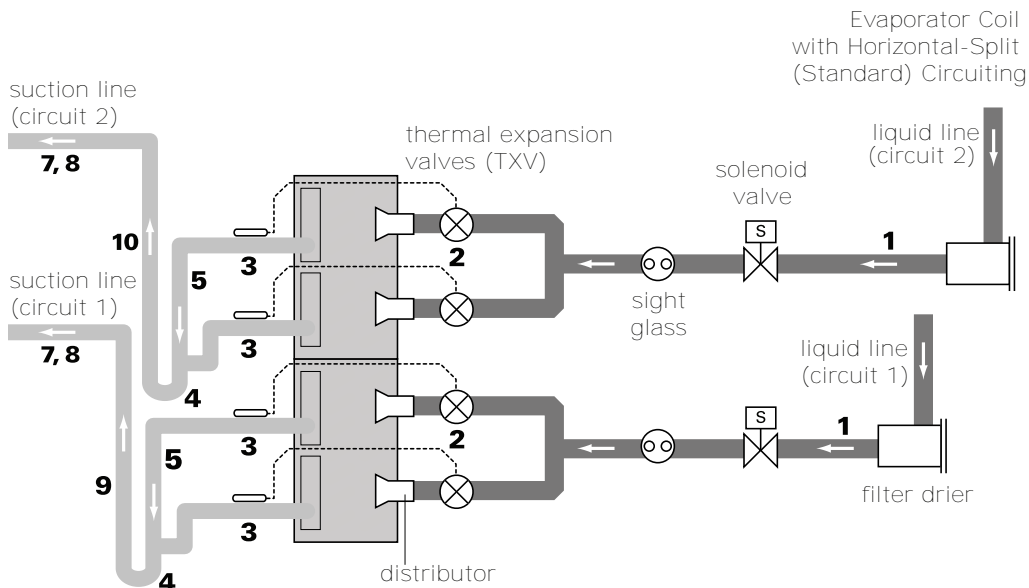
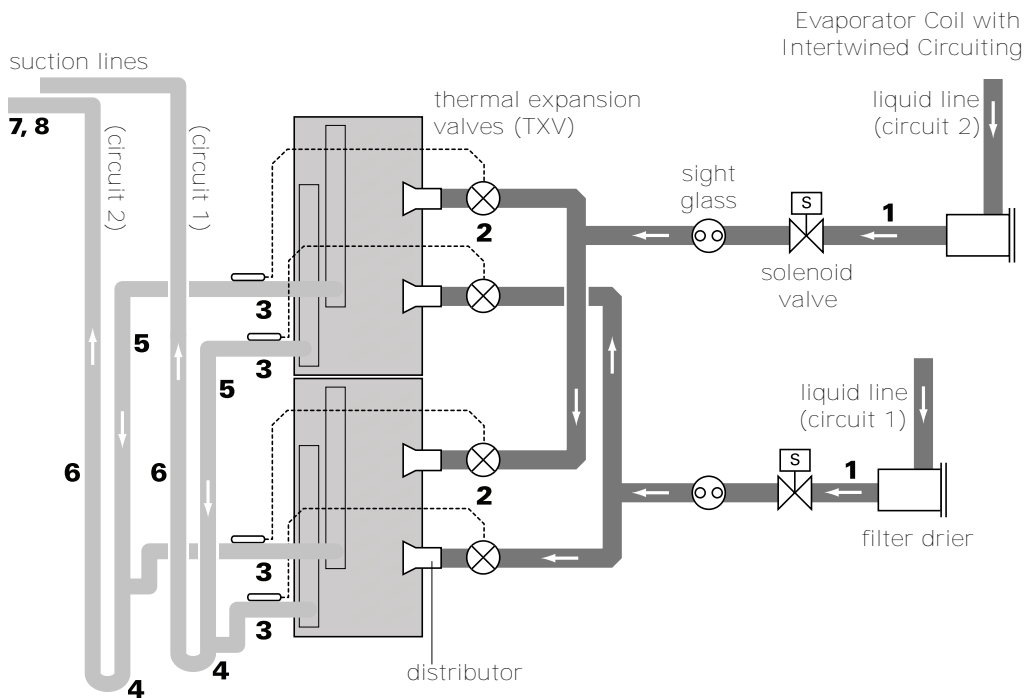

Figure 39. Intertwined



Hot Gas Bypass for Commercial Comfort-Cooling Applications

Hot gas bypass is not recommended for use on RAUK units. Coil Frost Protection and Froststat™ are the preferred methods of protecting the evaporator from coil frost. Coil Frost Protection will limit loading or unload the circuit capacity to minimize coil frosting conditions. When temperature falls below the Froststat setpoint, the circuit will deenergize. This action reduces the overall energy

consumption of the system while reliably maintaining system control.

For more information, see *Hot Gas Bypass Engineers Newsletter* (ADM-APN007*-EN).

Optional Pressure Gauges

When a unit is ordered with optional pressure gauges, (model number digit 16 = F), a set of gauges and the necessary mounting hardware ship with the unit. See “General Information,” p. 8 for ship-with location on unit. The mounting location and tubing configuration for the optional pressure gauges after field installation is shown below.

1. Assemble the valve depressor, flare nuts, 1/4-inch copper tubing, 90 degree flare elbows, gauge and gauge bracket together as shown in Detail A and B.

Note: *Wrap all appropriate pipe threads with Teflon tape before assembly.*
2. Remove the valve stem cap and place the valve depressor (with tubing connected) onto the valve stem and tighten.

Note: *Do not install the valve depressor without the tubing being connected. If gauges need to be replaced, remove valve depressor from valve stem, first, to prevent loss of refrigerant charge.*
3. Using the gauge bracket as a template for the self-tapping screws, mount the gauge bracket approximately 1/2-inch to 3/4-inch from the outer edge of the base rail, relative to the compressors for that circuit, as illustrated.
4. Apply 6-inch strips of edge protector to both side flanges of the gauge bracket, to prevent the bracket from cutting into the power wires.

Figure 40. Pressure gauges 20 to 60 ton units: plan view

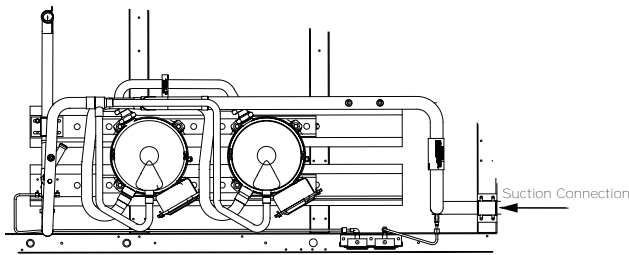

Figure 41. Pressure gauges 20 to 60 ton units: front view

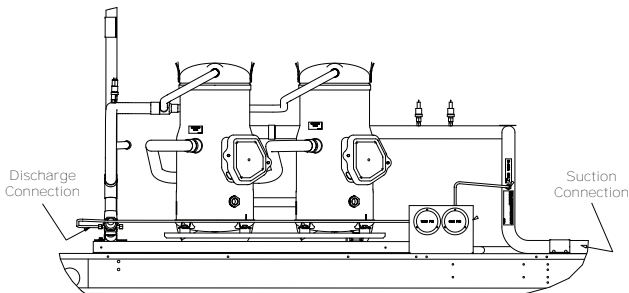
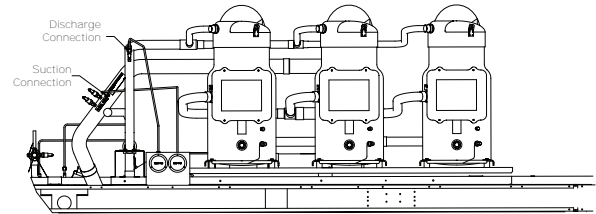

Figure 42. Pressure gauges 80 to 120 ton units: front view



Final Refrigerant Pipe Connections

To access the refrigerant pipe connections, remove the louvered side grills. See connection drawings in Dimensions and Weights chapter.

These condensing units are shipped with a Nitrogen holding charge. Install pressure gauges to the appropriate access valve(s) and take a reading.

- If no pressure is present, see “Leak Testing Procedure,” p. 61.
- If pressure is present, relieve the pressure before attempting to unsweat the seal caps.
- If refrigerant connections are not capped, but are “spun-end” tubes, use a tubing cutter to remove the end from the pipe.

NOTICE

Equipment Damage!
 Drilling or sawing pipe stubs could introduce copper chips into the system and cause equipment damage. Do not drill a hole in the seal caps or saw the ends of pipe stubs.

Brazing Procedures

⚠ WARNING

Explosion Hazard and Deadly Gases!
 Failure to follow all proper safe refrigerant handling practices could result in death or serious injury. Never solder, braze or weld on refrigerant lines or any unit components that are above atmospheric pressure or where refrigerant may be present. Always remove refrigerant by following the guidelines established by the EPA Federal Clean Air Act or other state or local codes as appropriate. After refrigerant removal, use dry nitrogen to bring system back to atmospheric pressure before opening system for repairs. Mixtures of refrigerants and air under pressure may become combustible in the presence of an ignition source leading to an explosion. Excessive heat from soldering, brazing or welding with refrigerant vapors present can form highly toxic gases and extremely corrosive acids.

⚠ WARNING

Explosion Hazard!

Failure to follow these instructions could result in death or serious injury or equipment or property-only damage.

Use only dry nitrogen with a pressure regulator for pressurizing unit. Do not use acetylene, oxygen or compressed air or mixtures containing them for pressure testing. Do not use hydrogen mixtures containing refrigerant and air above atmospheric pressure for pressure testing as they may become flammable and could result in an explosion. Refrigerant, when used as a trace gas should only be mixed with dry nitrogen for pressurizing units.

Proper brazing techniques are essential when installing refrigerant piping. The following factors should be kept in mind when forming sweat connections.

- When copper is heated in the presence of air, copper oxide forms. To prevent copper oxide from forming inside the tubing during brazing, sweep an inert gas, such as dry nitrogen, through the tubing. Nitrogen displaces air in the tubing and prevents oxidation of the interior surfaces. A nitrogen flow of one to three cubic feet per minute is sufficient to displace the air. Use a pressure regulating valve or flow meter to control the flow.
- Ensure that the tubing surfaces to be brazed are clean, and that the ends of the tubes have been carefully reamed to remove any burrs.
- Make sure the inner and outer tubes of the joint are symmetrical and have a close clearance, providing an easy slip fit. If the joint is too loose, the tensile strength of the connection will be significantly reduced. The overlap distance should be equal to the diameter of the inner tube.
- Wrap the body of each refrigerant line component with a wet cloth to keep it cool during brazing. Move any tube entrance grommets away for the brazing area.
Note: Use 40 to 45% silver brazing alloy (BAG-7 or BAG-28) on dissimilar metals. Use BCup-6 brazing alloy on copper to copper joints.
- If flux is used, apply it sparingly to the joint. Excessive flux can enter the system which will contaminate the refrigerant system.
- Apply heat evenly over the length and circumference of the joint to draw the brazing material into the joint by capillary action. Remove the brazing rod and flame from the joint as soon as a complete fillet is formed to avoid possible restriction in the line.
- Visually inspect the connection after brazing to locate any pin holes or crevices in the joint. The use of a mirror may be required, depending on the joint location.

Leak Testing Procedure

⚠ WARNING

Explosion Hazard!

Failure to follow these instructions could result in death or serious injury or equipment or property-only damage.

Use only dry nitrogen with a pressure regulator for pressurizing unit. Do not use acetylene, oxygen or compressed air or mixtures containing them for pressure testing. Do not use hydrogen mixtures containing refrigerant and air above atmospheric pressure for pressure testing as they may become flammable and could result in an explosion. Refrigerant, when used as a trace gas should only be mixed with dry nitrogen for pressurizing units.

⚠ WARNING

Explosion Hazard!

Failure to follow safe leak test procedures below could result in death or serious injury or equipment or property-only-damage.

Never use an open flame to detect gas leaks. Use a leak test solution for leak testing.

When leak testing a refrigerant system, observe all safety precautions.

Trane condensing units are shipped with a nitrogen holding charge. If there is no pressure, the unit must be leak tested to determine the location of leak.

Note: These service procedures require working with refrigerant, Do NOT release refrigerant to the atmosphere! The service technician must comply with all federal, state, and local laws.

Use refrigerant gas as a tracer for leak detection and use oil-pumped dry nitrogen to develop the required test pressure. Test the high and low side of the system at pressures dictated by local codes.

1. Close the field supplied liquid line service valve(s) installed near the evaporator and the compressor discharge service valve to isolate the system's high side from the low side. Pressure test the liquid line, discharge line, and condenser coils at pressures dictated by local codes. Do not exceed 10# above the pressure control settings.
2. Connect a refrigerant cylinder to the charging port of the liquid line service valve. Use the refrigerant to raise the high side pressure to 12 to 15 psig.
3. Disconnect the refrigerant cylinder. Connect a dry nitrogen cylinder to the charging port and increase the high side pressure. Do not exceed the condenser maximum working pressure listed on the unit nameplate.
4. Use a leak detector or soap bubbles to check for leaks. Check all piping joints, valves, etc.



Installation Mechanical

5. If a leak is located, use proper procedures to remove the refrigerant/nitrogen mixture, break the connection and remake as a new joint. Retest for leaks after making repairs.
6. Repeat the test procedure for the low side of the system, charging through the suction pressure gauge port or through an access provided on the suction line by the installer. Increase the system pressure to 100 psig.
7. If a leak is located, use proper procedures to remove the refrigerant/nitrogen mixture, break the connection and remake as a new joint. Retest for leaks after making repairs.
8. Open the liquid line service valve and the compressor discharge service valve.



Installation Mechanical — EVP

EVP Chilled Water Piping Requirements

- Install properly sized chilled water pipe between the EVP chiller and the supporting equipment. See “Chilled Water Piping,” p. 65 for recommended system components and guidelines.
- Install supply and return water side pressure gauges (with isolation valves.)
- Install thermometers in water supply and return piping.
- Install isolation (shutoff) valves in water supply and return piping.
- Install a properly sized strainer in the supply piping.
- Install blowdown (recommended) valve or plug in strainer cleanout.
- Install a balancing valve in the return piping.
- Install a water flow switch in the return piping.
- Install chilled solution sensor well and sensor in the water outlet piping.
- Install freezestat well and freezestat bulb in the water outlet piping.
- Install chiller piping drain with shutoff valve.
- Install 1/2-inch x 14 NPT stainless steel or PVC plug in braze plate chiller body.
- Flush the chilled solution piping system, if applicable.
- Connect the chilled solution piping to the chiller.
- The braze plate chiller is intended for indoor application. If a subfreezing location is required, contact Trane for installation precautions required to prevent damage.
- If using an acidic, commercial flushing solution to prevent damage to the internal evaporator components, flush all chilled solution piping before making the final connection to the EVP chiller.

TXV for Remote Chiller

Piping between TXV and Chiller, a braze plate heat exchanger (BPHE), must be 8 to 12-inch long and same size as BPHE inlet ID. Field supplied reducer(s) may be required at TXV. A bleed port valve is not required with brazed plate heat exchanger applications.

Notes:

- *Install reducers at the TXV outlet only.*
- *See Dimensions and Weights chapter for BPHE inlet dimensions.*
- *See Expansion Valve Selection tables in “Installation Mechanical — EVP,” p. 63 for valve selections.*

Typical Field-Installed EVP Chiller Evaporator Piping

NOTICE

Heat Exchanger Damage!

Failure to follow instructions below could result in refrigerant leaks or damage to the heat exchanger. The braze connections at the heat exchanger are stainless steel. Use 40-45% silver brazing alloy BAg-7 or BAg-29 for copper to steel refrigerant connections. Use flux sparingly to prevent plugging heat exchanger flow passages.

1. Install the TXV(s) directly to the unit liquid connection. See *Tube Size and Component Selection IntelliCore™ Split Systems (20 to 120 Tons) R-454B Refrigerant Microchannel Condensers Application Guide (SS-APG018*-EN)* for R-454B and *Tube Size and Component Selection RAUJ Split Systems (20 to 120 Tons) R-410A Refrigerant Microchannel Condensers Application Guide (SS-APG012*-EN)* for R-410A.

NOTICE

Evaporator Damage!

Failure to follow instructions below could result in evaporator damage.

To prevent evaporator damage and for proper refrigerant distribution, an 8-12” stub tube must be brazed between the expansion valve and the chiller entering refrigerant connection. This tube must be the same diameter as the heat exchanger connection ID. Use reducers only at the expansion valve. See dimension drawings for inlet dimensions.

2. Locate TXV bulb on top of the suction line 12-inch from the heat exchanger outlet.
3. Secure the bulb to the suction line with two clamps provided by the manufacturer and insulate the bulb.
4. Locate liquid line solenoid valve(s) near TXV.
5. Install freezestat well and freezestat bulb in the water outlet piping according to instructions enclosed in the kit as close to the evaporator as possible.

Figure 43. EVP chiller, typical refrigerant piping (2 circuit system)

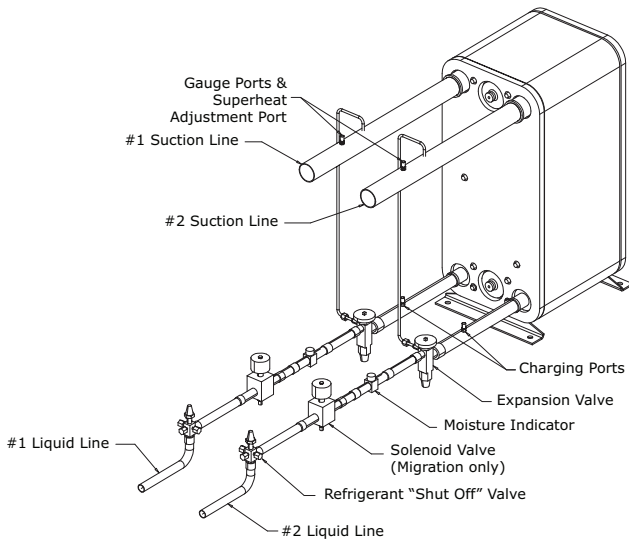

Remote EVP Chiller

Water Treatment

NOTICE

Proper Water Treatment Required!

The use of untreated or improperly treated water could result in scaling, erosion, corrosion, algae or slime.

Use the services of a qualified water treatment specialist to determine what water treatment, if any, is required. Trane assumes no responsibility for equipment failures which result from untreated or improperly treated water, or saline or brackish water.

The use of untreated or improperly treated water could result in scaling, erosion, corrosion, and algae or slime buildup in the heat exchanger. This will adversely affect system capacity. Proper water treatment must be determined locally and depends on the type of system and local water characteristics. Neither salt nor brackish water is recommended, use of either will lead to a shortened heat exchanger life. Trane encourages employment of a qualified water treatment specialist, familiar with local water conditions, to assist in the establishment of a proper water treatment program.

Water Flow Limits

NOTICE

Heat Exchanger and Compressor Damage!

Water flow rates beyond the heat exchanger limits could result in permanent damage to the heat exchanger and/or compressor.

Do not operate outside recommended flow rates.

The minimum and maximum water flow rates are given in the General Data section. Water flow rates below the tabulated values will result in laminar flow causing freeze-up problems, scaling, stratification and poor system control. Flow rates exceeding the maximum listed could result in very high pressure drop, erosion of the heat exchanger and damage to the water flow switch.

Water Temperature Limits

NOTICE

Heat Exchanger and Compressor Damage!

Failure to follow instructions below could result in heat exchanger and compressor damage from water freezing in brazed plate and rupturing separation between refrigerant and water flow channels. Leaving water temperatures below 42°F require glycol protection down to 15°F.

NOTICE

Evaporator Damage!

Circulating water temperatures above 125°F when the unit is not operating could result in evaporator damage.

Catalog chiller performance data is based on a water temperature drop of 10°F. Full load chilled water temperature drops from 8 to 14°F may be used as long as minimum and maximum water temperature and minimum and maximum flow rates are not violated. Leaving water temperatures below 42°F require freeze protection down to 15°F. The maximum water temperature that can be circulated through the chiller when the unit is not operating is 125°F. Evaporator damage could result above this temperature.

Short Water Loops

NOTICE

Compressor Damage!

Do not operate with water loops with less than five minutes circulation time as it could result in poor superheat control and compressor damage.

Adequate chilled water system water volume is an important system design parameter because it provides for stable chilled water temperature control and helps limit unacceptable short cycling of chiller compressors. Typically, a five-minute water loop circulation time is sufficient to prevent short water loop issues. Therefore, as a guideline, ensure the volume of water in the chilled water loop equals or exceeds five times the evaporator flow rate. For systems with a rapidly changing load profile the amount of volume should be increased.

Note: Water volumes should be calculated as close as possible to maintain constant water flow through the water loop.

Chilled Water Piping

Typical Water Piping

Figure below illustrates typical water piping components for remote chiller applications. (Remote Chiller accessory kit

includes strainer, water flow switch, pipe stubs, couplings, evaporator insulation and mounting legs, and a ship separate braze plate heat exchanger.)

Figure 44. EVP chiller — typical water piping

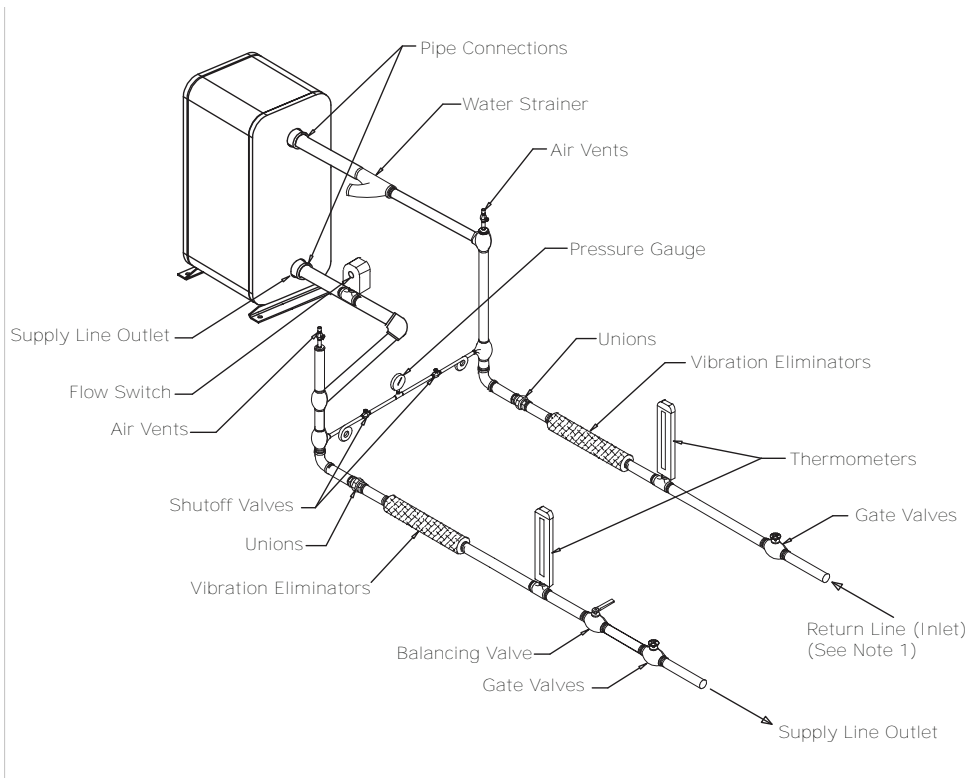

Notes:

- *Shutoff valves are required for evaporator servicing.*
- *Evaporator is shown for illustration purposes only.*
- *Water inlet, outlet diameter dimensional locations depend on unit size.*
- *Water connections at the evaporator are grooved.*
- *Field supplied 1/2-inch x 14 NPTE stainless steel or PVC plug required.*
- *Locate freeze-stat and discharge temperature sensors close to the water outlet.*
- *Install drain with shutoff valve at low point in leaving piping before system valve.*

Foreign matter in the chilled water system will increase pressure drop and reduce water flow. Installation of a properly selected strainer is also necessary to prevent debris larger than 0.039-in. from entering the heat exchanger. All building piping must be thoroughly flushed before making the final piping connections to the heat exchanger. The strainer must also be cleaned prior to initial start-up.

Important: *Start up without flushing building piping risks plugging chiller with debris and reducing capacity.*

To reduce heat loss and prevent condensation, insulation should be applied to piping. Expansion tanks are also

usually required to accommodate chilled water volume changes.

Braze Plate (BPHE) Chiller

Evaporator water inlet and outlet types, sizes and locations are shown in drawings in Dimensions and Weights chapter. Installation of a field provided 1/2-inch x 14 NPTE stainless steel or PVC plug is required.

Strainer

Install a strainer in the water supply line to protect the chiller from plugging with system piping debris. Strainers should be installed as close as practical to the heat



Installation Mechanical — EVP

exchanger water inlet (the remote chiller accessory kit includes strainer and piping to connect with BPHE). A field

provided blow down valve (recommended) or plug must be installed in strainer cleanout if not present.

Table 18. Chiller water pressure drop, Ft H₂O

Flow (GPM)	Size, Tons								
	20	25	30	40	50	60	80	100	120
25	3.2								
30	4.8	2.8							
35	6.0	3.7							
40	7.7	4.7	3.2						
45	9.5	5.8	4.0						
50	11.6	7.0	4.8	4.2					
60	16.3	9.7	6.8	6.0	4.3				
70	21.7	12.9	9.0	8.0	5.7				
80		16.4	11.5	10.3	7.4	5.1			
90		20.4	14.2	12.9	9.2	6.4			
100			17.3	15.7	11.3	7.8	4.3		
120				22.2	15.9	11.0	6.0	3.2	
140					21.4	14.8	8.1	4.2	
160					27.5	19.1	10.4	5.5	4.7
180						23.9	13.0	6.8	5.8
200							15.9	8.4	7.1
240							22.5	11.8	10.1
280								15.8	13.5
320								20.4	17.4
360								25.5	21.8
400									26.6

Chilled Water Flow Switch

NOTICE

Evaporator Damage!

Failure to follow instructions could result in evaporator damage.

To prevent evaporator damage, do not use water flow switch to cycle the system.

NOTICE

Heat Exchanger and Compressor Damage!

Water flow rates beyond the heat exchanger limits could result in permanent damage to the heat exchanger and/or compressor.

Do not operate outside recommended flow rates.

Figure 45. Optional flow switch

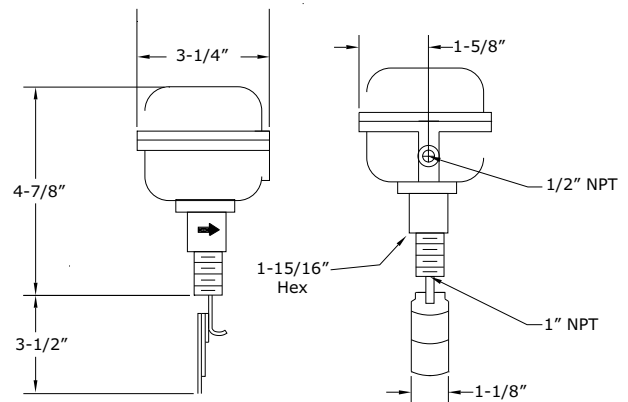

Install a flow switch or other flow sensing device to prevent or stop the compressor operation if the water flow drops below minimum limits. Locate the device in the chilled water return line as shown [Figure 44, p. 65](#). Install per switch manufacturer's instructions and refer to the unit schematics for the flow switch electrical interlock

connections. Adjust switch trip point to prevent operation below minimum limits.

The water flow switch included in the EVP chiller accessory kit must be adjusted to prevent flow below the minimum limit. To set the flow limit:

1. Establish minimum water flow.
2. Rotate the flow switch adjustment screw until the switch opens. This gets close to the correct setting but final adjustment must be done without water flow.
3. Beginning from water off, start flow and adjust GPM until the switch trips. If flow rate is below minimum, stop water flow and rotate adjusting screw accordingly.
4. Repeat until the switch trips at or above minimum flow.

Note: Use pressure gauge(s) and Water Pressure Drop table to determine water flow rate. See “General Data,” p. 10 for minimum flow limits.

Air Vents

Vents must be installed at high points in the piping system to facilitate air purging during the filling process. Air vents between the system shut off valve and heat exchanger are also useful for EVP chiller service and shutdown.

Water Pressure Gauges

NOTICE

Evaporator Damage!

Do not exceed 150 psig evaporator pressure as it could result in damage to the evaporator.

Install pressure gauge(s) to monitor the entering and leaving chilled water pressure, and strainer condition.

Water Shutoff Valves

Provide shutoff valves in the **Supply** and **Return** pipe near the chiller so the gauge(s), thermostats, sensors, strainer, etc., can be isolated during service.

Pipe Unions

Use pipe unions to simplify disassembly for system service. Use vibration eliminators to prevent transmitting vibrations through the water lines.

Thermometers

Install thermometers in the lines to monitor the evaporator entering and leaving water temperatures.

Balancing Valves

Install a balancing cock (valve) in the leaving water line. It will be used to establish a balanced flow.

Note: Both the entering and leaving water lines should have shutoff valves installed to isolate the evaporator for service.

Chiller Drain

Drain piping, with shutoff valve, must be installed at the lowest point between the chiller and system piping valves

to allow water removal for service and shutdown procedures. The drain must be piped to a suitable facility.

Note: Insure that the drain is closed before filling system with water.

Water Temperature Sensor

The temperature sensor and sensor well must be installed in the leaving water piping as close to the chiller as possible. Both devices are located inside the remote panel. Thermal paste is also provided inside the remote panel and must be used when installing the sensor into the sensor-well.

NOTICE

Equipment Damage!

Failure to use thermal paste could result in erratic temperature sensing resulting in equipment damage. Always use thermal paste on temperature sensor installation.

Figure below illustrates the sensor well dimensions.

Figure 46. Freezestat bulbwell, temperature sensor and well

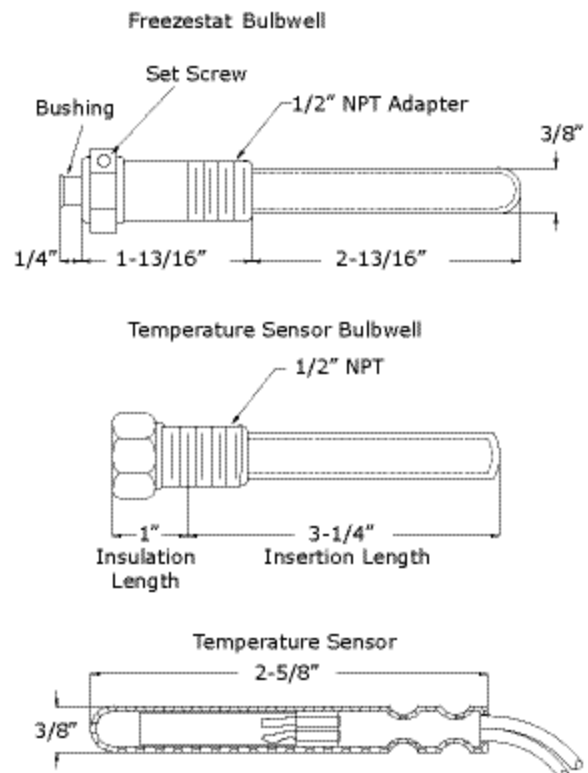

Freezestat

A bulbwell (located inside the remote panel) must be installed in the leaving water piping as close to the chiller as possible. It should be located upstream of the temperature sensor location. The freezestat, located within the remote panel, is equipped with a remote sensing bulb



Installation Mechanical — EVP

and 20 feet of capillary tube. The remote sensing bulb must be installed by the installing personnel. Thermal paste is also provided inside the remote panel and must be used when installing the bulb into the bulb-well. Figure above illustrates the bulbwell dimensions.

Important: *Isolate the water pumps from the system piping to avoid vibration transmission. Insulate all water piping. Use appropriate pipe sealant on all threaded connections.*

Final Water Piping Connections

1. Flush all water piping in the system thoroughly before making the final connections.

NOTICE

Heat Exchanger Damage!

Failure to follow instructions below could result in heat exchanger damage.

If an acidic commercial flushing solution is used, bypass the EVP chiller to prevent damage .

2. Clean strainer.
3. Connect the water pipe to the EVP chiller.
4. Make sure the 1/2-inch x 14 NPTE plug is installed.
5. Close the drain shutoff valve.
6. While filling the chiller system with solution, vent the air from the system at the highest points.



Installation Electrical

Electrical

Note: Local codes may take precedence.

Table 19. IntelliCore electrical data (R-410A)

Unit Size (Ton)	Rated Voltage ^(a)	Condenser Fan Motor ^(b)		CPT Amps	Compressor Motor ^(b)												Unit Characteristics	
		Qty	FLA		RLA				LRA				MCA ^(c)				MOP ^(d)	
					1A	1B	1C	2A	2B	2C	1A	1B	1C	2A	2B	2C		
20	200/60/3	2	4.1	10.0	40.3	40.3	—	—	—	—	—	267	267	—	—	—	109	125
	230/60/3	2	4.1	9.0	40.3	40.3	—	—	—	—	—	267	267	—	—	—	108	125
	460/60/3	2	1.8	4.5	19.1	19.1	—	—	—	—	—	142	142	—	—	—	52	70
	575/60/3	2	1.4	3.5	15.8	15.8	—	—	—	—	—	103	103	—	—	—	42	50
25	200/60/3	3	4.1	10.0	40.3	49.5	—	—	—	—	—	267	315	—	—	—	125	150
	230/60/3	3	4.1	9.0	40.3	45.6	—	—	—	—	—	267	315	—	—	—	119	150
	460/60/3	3	1.8	4.5	19.1	22.6	—	—	—	—	—	142	158	—	—	—	58	70
	575/60/3	3	1.4	3.5	15.8	19.1	—	—	—	—	—	103	136	—	—	—	48	60
30	200/60/3	3	4.1	10.0	58.1	58.1	—	—	—	—	—	345	345	—	—	—	154	200
	230/60/3	3	4.1	9.0	53.1	53.1	—	—	—	—	—	345	345	—	—	—	141	175
	460/60/3	3	1.8	4.5	26.5	26.5	—	—	—	—	—	155	155	—	—	—	70	90
	575/60/3	3	1.4	3.5	23.1	23.1	—	—	—	—	—	126	126	—	—	—	60	80
40	200/60/3	4	4.1	10.0	40.3	40.3	—	40.3	40.3	40.3	—	267	267	—	267	—	198	225
	230/60/3	4	4.1	9.0	40.3	40.3	—	40.3	40.3	40.3	—	267	267	—	267	—	197	225
	460/60/3	4	1.8	4.5	19.1	19.1	—	19.1	19.1	19.1	—	142	142	—	142	—	93	110
	575/60/3	4	1.4	3.5	15.8	15.8	—	15.8	15.8	15.8	—	103	103	—	103	—	77	90
50	200/60/3	6	4.1	10.0	44.8	49.5	—	44.8	49.5	49.5	—	304	315	—	304	315	236	250
	230/60/3	6	4.1	9.0	42.3	45.6	—	42.3	45.6	45.6	—	304	315	—	304	315	221	250
	460/60/3	6	1.8	4.5	20.4	22.6	—	20.4	22.6	22.6	—	147	158	—	147	158	107	125
	575/60/3	6	1.4	3.5	17.2	19.1	—	17.2	19.1	19.1	—	122	136	—	122	136	90	100
60	200/60/3	6	4.1	10.0	58.0	58.0	—	58.0	58.0	58.0	—	345	345	—	345	345	282	300
	230/60/3	6	4.1	9.0	53.0	53.0	—	53.0	53.0	53.0	—	345	345	—	345	345	259	300
	460/60/3	6	1.8	4.5	26.5	26.5	—	26.5	26.5	26.5	—	155	155	—	155	155	128	150
	575/60/3	6	1.4	3.5	23.1	23.1	—	23.1	23.1	23.1	—	126	126	—	126	126	111	125
80	200/60/3	8	4.1	10.0	60.0	60.0	60.0	60.0	60.0	60.0	60.0	320	320	320	320	320	418	450
	230/60/3	8	4.1	9.0	54.8	54.8	54.8	54.8	54.8	54.8	54.8	320	320	320	320	320	385	400
	460/60/3	8	1.8	4.5	26.7	26.7	26.7	26.7	26.7	26.7	26.7	160	160	160	160	160	186	200
	575/60/3	8	1.4	3.5	21.4	21.4	21.4	21.4	21.4	21.4	21.4	135	135	135	135	135	149	150

Table 19. IntelliCore electrical data (R-410A) (continued)

Unit Size (Ton)	Rated Voltage ^(a)	Condenser Fan Motor ^(b)		CPT Amps	Compressor Motor ^(b)												Unit Characteristics		
		Qty	FLA		RLA				LRA				MCA ^(c)				MOP ^(d)		
					1A	1B	1C	2A	2B	2C	1A	1B	1C	2A	2B	2C			
100	230/60/3	12	4.1	9.0	55.5	55.5	72.5	55.5	55.5	72.5	55.5	320	320	485	320	320	485	444	500
	460/60/3	12	1.8	4.5	27.8	27.8	36.3	27.8	27.8	36.3	27.8	160	160	215	160	160	215	219	250
	575/60/3	12	1.4	3.5	22.2	22.2	29.0	22.2	22.2	29.0	22.2	135	135	175	135	135	175	175	200
120	460/60/3	12	1.8	4.5	36.3	36.3	36.3	36.3	36.3	36.3	36.3	215	215	215	215	215	215	253	300
	575/60/3	12	1.4	3.5	29.0	29.0	29.0	29.0	29.0	29.0	29.0	175	175	175	175	175	175	202	225

^(a) Voltage Utilization Range is +/- 10% of Rated voltage (use range): 200/60/3 (180-220), 230/60/3 (207-253), 460/60/3 (414-506), 575/60/3 (517-633)

^(b) Electrical information is for each individual motor.

^(c) Minimum circuit ampacity (MCA) is 125 percent of the RLA of the largest compressor motor plus the total RLA/FLA of the remaining motors and CPT amps.

^(d) Maximum Overcurrent Protection Device permitted by NEC 440-22 is 225 percent of the RLA of the largest compressor motor plus the total RLA/FLA of the remaining motors and CPT amps.

Table 20. IntelliCore electrical data (R-454B)

Unit Size (Ton)	Rated Voltage ^(a)	Condenser Fan Motor ^(b)		CPT Amps	Compressor Motor ^(b)												Unit Characteristics		
		Qty	FLA		RLA				LRA				MCA ^(c)	MOP ^(d)					
					1A	1B	1C	2A	2B	2C	1A	1B			1C	2A	2B	2C	
20	200/60/3	2	4.1	49.6	34.7	—	—	—	—	—	—	—	336	255	—	—	—	115	150
	230/60/3	2	4.1	47.3	30.1	—	—	—	—	—	—	—	336	255	—	—	—	107	150
	460/60/3	2	1.8	21.6	15.1	—	—	—	—	—	—	—	141	123	—	—	—	51	70
	575/60/3	2	1.4	17.2	12.1	—	—	—	—	—	—	—	109	94	—	—	—	40	50
25	200/60/3	3	4.1	62.1	40.1	—	—	—	—	—	—	—	386	255	—	—	—	141	200
	230/60/3	3	4.1	54.0	34.9	—	—	—	—	—	—	—	386	255	—	—	—	124	175
	460/60/3	3	1.8	27.0	17.4	—	—	—	—	—	—	—	182	140	—	—	—	62	80
	575/60/3	3	1.4	21.6	14.0	—	—	—	—	—	—	—	131	108	—	—	—	49	70
30	200/60/3	3	4.1	32.3	46.0	46.0	—	—	—	—	—	—	203	304	304	—	—	159	200
	230/60/3	3	4.1	29.5	42.3	42.3	—	—	—	—	—	—	203	304	304	—	—	146	175
	460/60/3	3	1.8	14.7	21.8	21.8	—	—	—	—	—	—	98	147	147	—	—	74	90
	575/60/3	3	1.4	11.9	17.2	17.2	—	—	—	—	—	—	84	122	122	—	—	59	70
40	200/60/3	4	4.1	40.5	46.0	—	—	—	40.5	46.0	—	—	267	304	—	267	304	211	250
	230/60/3	4	4.1	40.3	42.3	—	—	—	40.3	42.3	—	—	267	304	—	267	304	202	225
	460/60/3	4	1.8	19.1	21.8	—	—	—	19.1	21.8	—	—	142	147	—	142	147	99	110
	575/60/3	4	1.4	15.8	17.2	—	—	—	15.8	17.2	—	—	103	122	—	103	122	80	90
50	200/60/3	6	4.1	46.0	47.4	—	—	—	46.0	47.4	—	—	304	315	—	304	315	234	250
	230/60/3	6	4.1	42.3	45.6	—	—	—	42.3	45.6	—	—	304	315	—	304	315	221	250
	460/60/3	6	1.8	21.8	21.8	—	—	—	21.8	21.8	—	—	147	158	—	147	158	108	125
	575/60/3	6	1.4	17.2	19.1	—	—	—	17.2	19.1	—	—	122	136	—	122	136	90	100
60	200/60/3	6	4.1	62.4	62.4	—	—	—	62.4	62.4	—	—	337	337	—	337	337	300	350
	230/60/3	6	4.1	56.9	56.9	—	—	—	56.9	56.9	—	—	337	337	—	337	337	276	300
	460/60/3	6	1.8	28.5	28.5	—	—	—	28.5	28.5	—	—	155	155	—	155	155	137	150
	575/60/3	6	1.4	23.1	23.1	—	—	—	23.1	23.1	—	—	126	126	—	126	126	111	125
80	200/60/3	8	4.1	52.2	52.2	52.2	52.2	52.2	52.2	52.2	52.2	52.2	308	308	308	308	308	370	400
	230/60/3	8	4.1	51.5	51.5	51.5	51.5	51.5	51.5	51.5	51.5	51.5	308	308	308	308	308	364	400
	460/60/3	8	1.8	25.3	25.3	25.3	25.3	25.3	25.3	25.3	25.3	25.3	160	160	160	160	160	178	200
	575/60/3	8	1.4	20.3	20.3	20.3	20.3	20.3	20.3	20.3	20.3	20.3	135	135	135	135	135	142	150
100	200/60/3	12	4.1	52.2	52.2	81.2	81.2	81.2	81.2	81.2	81.2	81.2	308	308	528	528	528	451	500
	230/60/3	12	4.1	51.5	51.5	70.6	70.6	70.6	70.6	70.6	70.6	70.6	308	308	528	528	528	424	450
	460/60/3	12	1.8	25.3	25.3	35.6	35.6	35.6	35.6	35.6	35.6	35.6	160	160	215	215	215	208	225
	575/60/3	12	1.4	20.3	20.3	28.5	28.5	28.5	28.5	28.5	28.5	28.5	135	135	175	175	175	166	175
120	460/60/3	12	1.8	35.6	35.6	35.6	35.6	35.6	35.6	35.6	35.6	35.6	215	215	215	215	215	249	250
	575/60/3	12	1.4	28.5	28.5	28.5	28.5	28.5	28.5	28.5	28.5	28.5	175	175	175	175	175	199	225

(a) Voltage Utilization Range is +/- 10% of Rated voltage (use range): 200/60/3 (180-220), 230/60/3 (207-253), 460/60/3 (414-506), 575/60/3 (517-633)
 (b) Electrical information is for each individual motor.
 (c) Minimum circuit ampacity (MCA) is 125 percent of the RLA of the largest compressor motor plus the total RLA/FLA of the remaining motors and CPT amps.
 (d) Maximum Overcurrent Protection Device permitted by NEC 440-22 is 225 percent of the RLA of the largest compressor motor plus the total RLA/FLA of the remaining motors and CPT amps.

Wiring Requirements

Main Unit Power Wiring

⚠ WARNING

Hazardous Voltage!

Failure to disconnect power before servicing could result in death or serious injury.

Disconnect all electric power, including remote disconnects before servicing. Follow proper lockout/tagout procedures to ensure the power can not be inadvertently energized. Verify that no power is present with a voltmeter.

⚠ WARNING

Proper Field Wiring and Grounding Required!

Failure to follow code could result in death or serious injury.

All field wiring **MUST** be performed by qualified personnel. Improperly installed and grounded field wiring poses **FIRE** and **ELECTROCUTION** hazards. To avoid these hazards, you **MUST** follow requirements for field wiring installation and grounding as described in NEC and your local/state/national electrical codes.

⚠ WARNING

Electrical Shock Hazard!

Failure to follow instructions below could result in death or serious injury.

Properly connect the system's oversized protective earthing (grounding) terminal(s).

NOTICE

Use Copper Conductors Only!

Failure to use copper conductors could result in equipment damage as the equipment was not designed or qualified to accept other types of conductors.

- Inspect all control panel components. Tighten any loose connections.
- If applicable, confirm the unit disconnect switch (1QB1) is in the OFF position.
- Confirm the unit control circuit switch (1S1) is in the "OFF" position.
- Verify that the power supply to the unit complies with the unit nameplate specification.
- See "Unit Dimensions," p. 19 for electrical wire entry details.
- Table 21, p. 72 lists the field connection wire ranges for the unit terminal block/disconnect switch and ground lugs.
- Connect properly sized and protected power supply wiring to the unit terminal block (1XD1) or unit disconnect switch (1QB1).
- Confirm that phasing to the unit is correct (See "Electrical Phasing," p. 98).
- Confirm the voltage supply is within 10% of the rated voltage on the unit nameplate (See "Voltage Imbalance," p. 98).
- Connect properly sized ground wires from the unit ground terminal to an earth ground.
- Confirm the holes provided in the outer panels for electrical wiring entry are closed after installation is complete.
- Refer to the unit diagrams for wiring details, if necessary.

Table 21. Field connection wire range

Notes:	Component type/size	Wire Qty per phase	Wire size range
Terminal block and Standard SCCR Disconnect Switch sizes are calculated by selecting the size greater than or equal to 1.15 x (sum of unit loads) See unit literature for unit load values	510A Terminal Block	2	6 AWG - 250 kcmil
	150A Disconnect Switch (Standard SCCR)	1	14 AWG - 3/0 AWG
	250A Disconnect Switch (Standard SCCR)	1	4 AWG - 350 kcmil ^(a)
	400A Disconnect Switch (Standard SCCR)	2	2/0 AWG - 500 kcmil
	600A Disconnect Switch (Standard SCCR)	2	2/0 AWG - 500 kcmil
High SCCR Disconnect Switch sizes are calculated by selecting the size greater than or equal to 1.25 x (sum of unit loads) See unit literature for unit load values	150A Disconnect Switch (High SCCR)	1	14 AWG - 3/0 AWG
	250A Disconnect Switch (High SCCR)	1	4 AWG - 350 kcmil ^(a)
	400A Disconnect Switch (High SCCR)	2	2/0 AWG - 500 kcmil
	600A Disconnect Switch (High SCCR)	2	2/0 AWG - 500 kcmil

Table 21. Field connection wire range (continued)

Notes:	Component type/size	Wire Qty per phase	Wire size range
Each unit is provided with two large ground lugs and one small ground lug	Large ground lug	1	6 AWG - 2/0 AWG ^(b)
	Small ground lug	1	14 AWG - 2 AWG ^(b)

^(a) 250A Disconnect Switches may require lug kit S1A59551 to be installed to allow for connection to 4 - 2/0 AWG wires. This kit is provided with the unit.

^(b) Ground lug torque = 35 in-lbs for 14-10 AWG, 40 in-lbs for 8 AWG, 45 in-lbs for 6-4 AWG, 50 in-lbs for 3-2/0 AWG.

Disconnect Switch with External Handle

Units ordered with a factory mounted disconnect switch come equipped with an externally mounted handle. This allows the operator to disconnect power from the unit without having to open the control panel door. The handle has three positions:

- **ON** – Indicates that the disconnect switch is closed, allowing the main power supply to be applied to the unit.
- **OFF** - Indicates that the disconnect switch is open, interrupting the main power supply to the unit.
- **RESET/LOCK** – Turning the handle to this position resets or disconnects the device. To disconnect, the handle must be turned to the RESET/LOCK position. Pulling the spring loaded thumb key out, so the lock shackle can be placed between the handle and the thumb key, locks the handle so the unit cannot be energized. Turning the handle to this position also releases the handle from the disconnect switch, allowing the control panel door to be opened.

The handle can be locked in the OFF position by:

1. While holding the handle in the OFF position, push the spring loaded thumb key, attached to the handle, into the base slot.
2. Place the lock shackle between the handle and the thumb key. This will prevent it from springing out of position.

Figure 47. Disconnect switch external handle

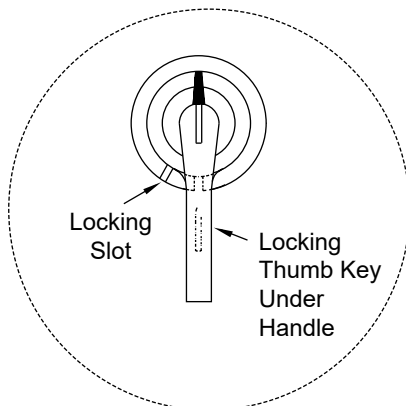

250A Disconnect Switch Wire Binding Screws

The 250A disconnect switch (standard and high SCCR) installed for main power connection accommodates 4 AWG – 350 kcmil wires in the OFF side. As shipped from the factory, the wire binding screws only accommodate 3/0 AWG – 350 kcmil wires. If 4 AWG – 2/0 AWG field power wiring is used, then the factory installed wire binding screws must be replaced with those that are provided with the kit installed near the disconnect switch (these screws should have a blue top surface). See the kit for instructions on changing the wire binding screws.

Controls Wiring

⚠ WARNING

Hazardous Voltage!

Failure to disconnect power before servicing could result in death or serious injury.

Disconnect all electric power, including remote disconnects before servicing. Follow proper lockout/tagout procedures to ensure the power can not be inadvertently energized. Verify that no power is present with a voltmeter.

⚠ WARNING

Proper Field Wiring and Grounding Required!

Failure to follow code could result in death or serious injury.

All field wiring **MUST** be performed by qualified personnel. Improperly installed and grounded field wiring poses **FIRE** and **ELECTROCUTION** hazards. To avoid these hazards, you **MUST** follow requirements for field wiring installation and grounding as described in NEC and your local/state/national electrical codes.

NOTICE

Use Copper Conductors Only!

Failure to use copper conductors could result in equipment damage as the equipment was not designed or qualified to accept other types of conductors.



Installation Electrical

⚠ WARNING

Electrical Shock Hazard!

Failure to follow instructions below could result in death or serious injury.
Do not mix Class 1 and Class 2 voltage wiring in an enclosure or on a controller without an approved barrier between wiring.

NOTICE

Component Failure!

Resistance in excess of 3 ohms per conductor could result in component failure due to insufficient AC voltage supply.
Do not exceed three (3) ohms per conductor for the length of the run.

- Inspect all control panel components. Tighten any loose connections.
- If applicable, confirm the unit disconnect switch (1QB1) is in the OFF position.
- Confirm the unit control circuit switch (1S1) is in the OFF position.
- See “Unit Dimensions,” p. 19 for electrical wire entry details.
- Do not run the low voltage wiring in the same conduit with the high voltage wiring.
- If desired, remove jumpers and install Emergency Stop switch.
- If desired, remove jumpers and install Equipment Stop switch.
- Connect refrigerant leak sensor auxiliary contacts to allow for operation of the condensing unit.
- Connect properly sized wiring to the liquid line solenoid valve(s).
- If applicable, connect properly sized wiring to the hot gas bypass solenoid valve(s), to operate with the unit.
- See the appropriate Controls section below for further wiring details that vary, depending on unit controls type.
- Confirm the holes provided in the outer panels for electrical wiring entry are closed after installation is complete.
- Refer to the unit diagrams for wiring details, if necessary.

No Controls Units

- Connect Froststat switch(es).
- Connect the Fan Interlock switch.
- Connect the Compressor request contacts.

EVP Controls Units

- Connect discharge temperature sensor.
- If applicable, connect remote setpoint potentiometer.

- Connect the Flow switch and Pump Interlock switch.
- Connect the Freezestat switch.

VAV Controls Units

- Connect discharge temperature sensor.
- If applicable, connect remote setpoint potentiometer.
- Connect Froststat switch(es).
- If applicable, connect the Outdoor Air damper actuator.
- Connect the Fan Interlock switch.

Table 22. Control wire selections

Wire Gauge	Ohms per 1000 feet	Max Wire Length (ft)
18	8	500
16	5	1000
14	3	2000
12	2	3000

Table 23. AC conductors

Distance from Unit to Control	Recommended Wire Size
000 - 460 feet	18 AWG
461 - 732 feet	16 AWG
733 - 1000 feet	14 AWG

Table 24. DC conductors

Distance from Unit to Control	Recommended Wire Size
000 - 499 feet	16 AWG
500 - 1000 feet	14 AWG

Refrigerant Leak Detection Input

IntelliCore™ Cooling Condenser Section units require a refrigerant leak detection input for safe unit operation. Do not ever jumper across the refrigerant sensor status input. The leak sensor will be mounted in the paired air handler unit and hard wired to a terminal strip in the main control panel. Symbio™ 800 shall accept an isolated contact closure input suitable for customer connection to hard wire a leak sensor. The contact closure status shall be monitored by a Symbio 800 binary input. Contact closure represents a unit operation request, and contact opening represents compressor operation disabling.

24V Transformer

A 115Vac primary - 24Vac secondary- 75VA transformer is provided with the following configurations/options:

- 20-25 ton units with two stage compressors
- Low Ambient option
- Expansion Module option

When the Expansion Module option is installed without the other configurations/options, the full 75VA is available for customer use. However, the 20-25 ton units will utilize 5VA

and the low ambient option will utilize up to 10VA. Because of the multiple uses of this transformer, it is possible that only 60VA may be available for customer use.

EVP Chiller Control

Each unit ordered for EVP Chiller applications (digit 9 in the model number), is shipped with the following controls:

- EVP Remote Panel
- Freezestat
- Discharge Temperature Sensor
- Freezestat Bulb well
- Discharge Temperature Sensor Well

The installation of the freezestat bulb well, freezestat bulb, and the discharge temperature sensor was discussed in the “Chilled Water Piping,” p. 65. Refer to that section for their installation locations and dimensional data.

The remote panel must be mounted indoors and within 20 feet of the chiller. Figure below illustrates the remote panel dimensional data, the component locations, the locations for the ship-with items, grounding lugs, and the field connection terminal strip. Refer to the EVP remote panel schematic and unit schematics for the interconnecting points between the remote panel and the unit’s control panel.

Figure 48. EVP remote panel

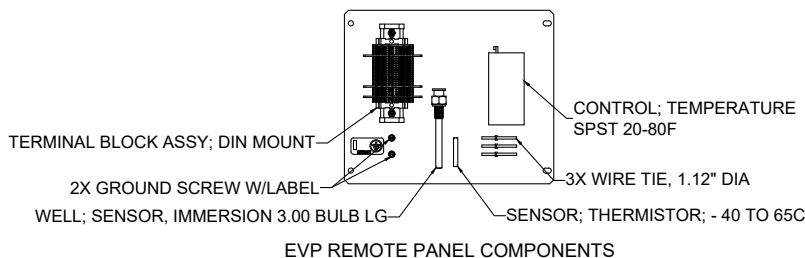
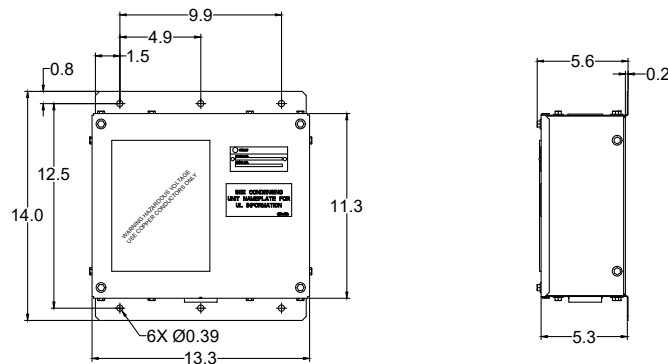

⚠ WARNING

Proper Field Wiring and Grounding Required!

Failure to follow code could result in death or serious injury.

All field wiring **MUST** be performed by qualified personnel. Improperly installed and grounded field wiring poses **FIRE** and **ELECTROCUTION** hazards. To avoid these hazards, you **MUST** follow requirements for field wiring installation and grounding as described in **NEC** and your local/state/national electrical codes.

Operating Principles

Component Locations

Condenser Fans

Figure 49. Condenser fan locations: 20 to 60 ton units

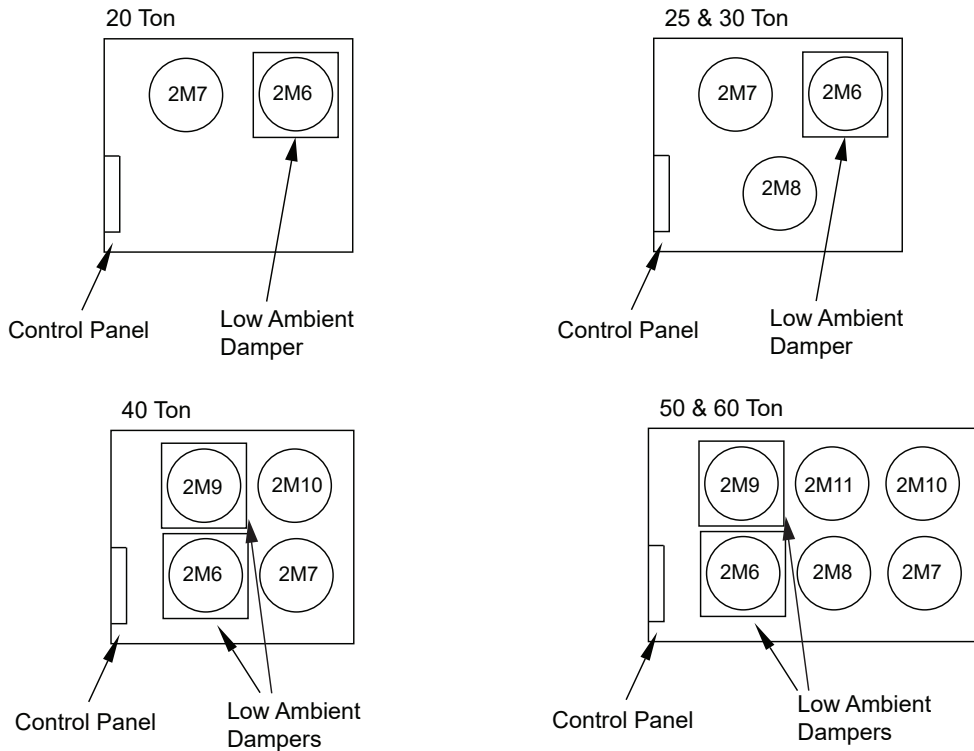
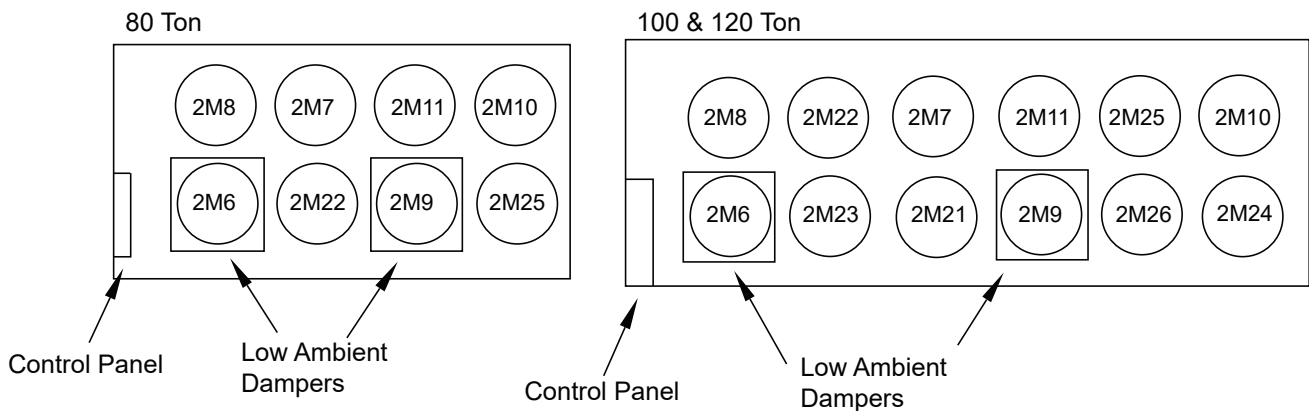

Figure 50. Condenser fan locations: 80 to 120 ton units



Compressors

Figure 51. Compressor locations: 20 to 60 ton units

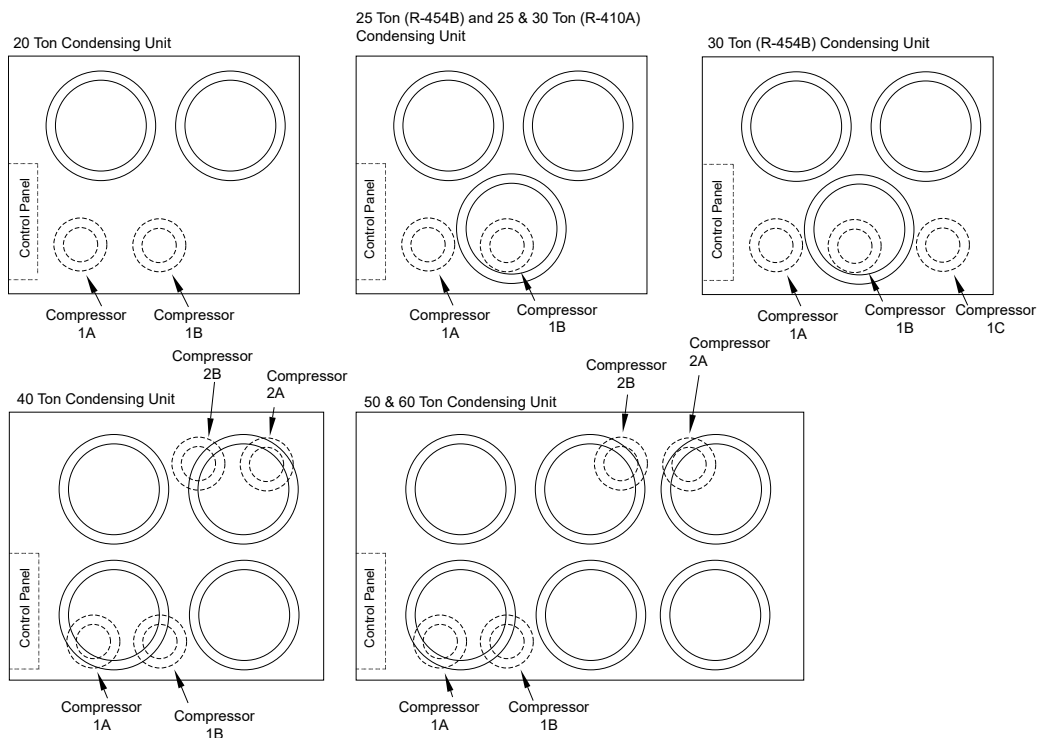
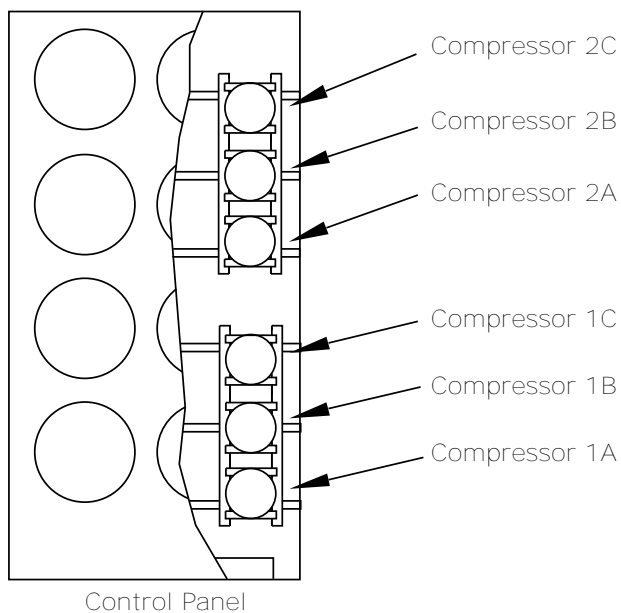

Figure 52. Compressor locations: 80 to 120 ton units



Sequence of Operations

Auto/Stop

The user interface home screen displays unit mode of Stop or Auto.

- **Auto** — is indicated when in automatic control.

- **Stopped** — is indicated when the unit is stopped or when an override is preventing operation.

The following functions can intervene or override normal operation and are listed in the order of priority:

1. **Local Stop** — is performed by the user interface **Stop** button. The controller performs a **Normal Shutdown**

Operating Principles

process unless the user selects **Immediate Shutdown** at the user interface when prompted.

- a. **Normal Shutdown** — In a normal shutdown situation, compressors, condenser fans, and other systems of the unit are allowed to go through an orderly shutdown sequence. For example, compressors continue to run for any remaining Minimum Run time.
 - b. **Immediate Shutdown** — If an immediate shutdown is selected, compressors, condenser fans, and all other devices are immediately stopped. A normal shutdown already in progress will be expedited. The use of this feature is discouraged. The normal shutdown sequence is recommended for equipment reliability.
2. **Emergency Stop** — Symbio™ 800 accepts a dry contact closure input suitable for customer connection to request Stop or Auto modes from an external device. The Emergency Stop input is normally closed which represents an Auto request. Contact opening will perform an Immediate Stop and generate a latching diagnostic. To return to Auto operation, the input must be closed, and a manual reset must be performed.
 3. **Equipment Stop** — Symbio 800 accepts a dry contact closure input suitable for customer connection to request Stop or Auto modes from an external device. The Equipment Stop binary input is normally closed which represents an Auto request. Contact opening will perform an Immediate Stop. The unit will automatically return to Auto operation when the input is closed.
 4. **Manual Control** — Manual control is intended for servicing the unit. It provides manual control of all valve relays, outdoor air damper(s), low ambient damper, control box ventilation fan, condenser fans, and compressors. Single or multiple component controls may be overridden. Remaining controls set to Auto will enforce limits to protect the unit from damage. Diagnostics remain active to protect the unit from damage, refer to the Programming Guide (SS-SVP018*-EN) for further information.

Manual Control can be set from the **Manual Control Settings** page on the user interface. Manual control varies in design, but all have an automatic mode which is the default mode for most unit operation. Once a manual override is set to manual, it will remain in manual until one of the following occur:

- Manual override is set back to automatic control by setting the individual overrides to Auto.
- Power is cycled.
- The Manual Overrides Timer expires.
- The operator selects **Clear All Manual Overrides** from the operator display or Tracer TU.

Important: *Manual Control is for experienced service personnel only.*

If a Service Tool requires the unit to be in user interface Stop for an operation (for example, binding, configuration,

or software download) the Service Tool will send the Symbio 800 a user interface Stop command. A Service Tool screen is displayed giving the user an opportunity to allow or cancel the operation. This executes a user interface Stop command as if it had been done from the user interface including storing through a power cycle. After this occurs, the only way the unit can be set back to user interface Auto is through the user interface directly.

Figure 53. Auto/Stop

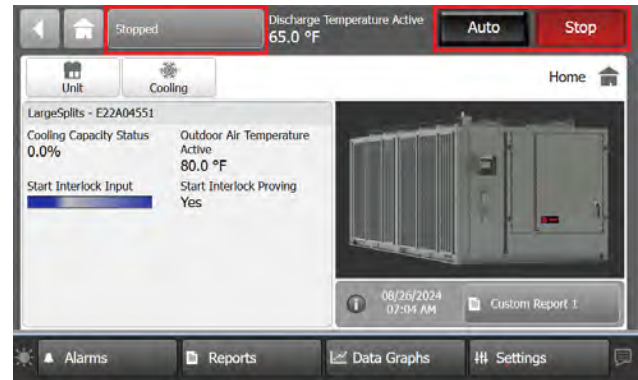

Figure 54. Immediate Shutdown

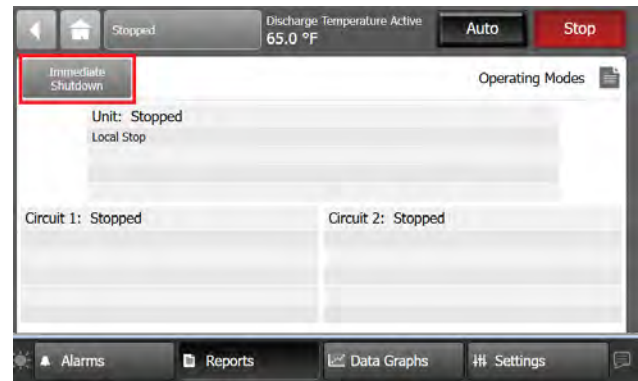
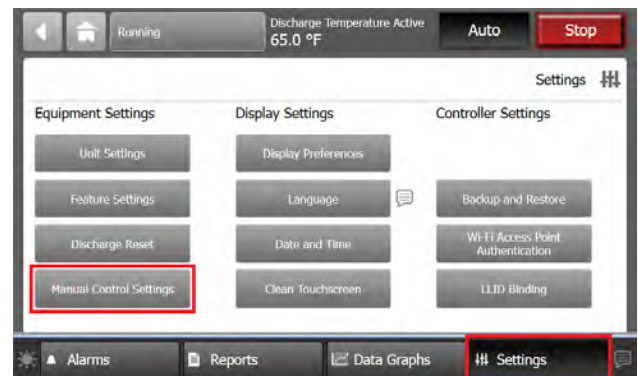

Figure 55. Manual Control Settings



Power Up Start Display

When power is applied to the unit, or the controller is reset, and the unit can run, a user adjustable Power-Up Start

Delay setting is enforced to allow staggered starts of multiple units. The user interface home screen displays Run Inhibit when active. Power Up Delay Inhibit, with remaining minutes and seconds, will be displayed on user interface operating modes screen. Power-Up Start Delay is also applied to Rapid Restart and Economizing.

Figure 56. Power Up Delay Inhibit



Fan/Pump Interlock

The Fan/Pump Interlock is a normally open binary input that is used to indicate the supply fan or water pump has been energized. The interlock input must be closed for five continuous seconds for the input to be proven before the unit will start.

No System Control

Compressor run request is wired to the terminal strip inside the main control panel. Symbio™ 800 will start compressors based on compressor request once the Interlock has been proven. There is not a prescribed staging sequence; however, Symbio 800 has Adaptive Control™ and additional safeties for longer life and reliability.

Discharge Temperature Control

Discharge Temperature Control uses available cooling capacity to deliver the required temperature at the discharge of the unit. A discharge temperature sensor is required for operation. In cool mode, the control uses cooling sources to deliver temperature as required by the Discharge Cooling Setpoint.

Table 25. Discharge temperature sensor temperature vs. resistance

°F	Nominal Resistance (in 1000 ohms)
-40	346.10
-30	241.70
-20	170.10
-10	121.40
0	87.56
10	63.80

Table 25. Discharge temperature sensor temperature vs. resistance (continued)

°F	Nominal Resistance (in 1000 ohms)
20	46.94
30	34.85
40	26.22
50	19.96
60	15.33
70	11.89
80	9.30
90	7.33
100	5.82
110	4.66
120	3.76
130	3.05
140	2.50

EVP Temperature Control

EVP system control provides Brazed Plate Heat Exchanger (BPHE) leaving water temperature control to the desired cooling temperature setpoint. A discharge temperature sensor is required for operation. Leaving water temperature control provides cooling capacity staging to match the existing cooling load. The objective is stable leaving water temperature control while minimizing cooling capacity variation.

Differential to Start / Stop

Differential to Start / Stop provides important control to minimize rapid on-off cycling for very low load conditions. Compressor cycle times are extended to provide improved refrigeration system oil circulation.

The unit starts the first compressor when Differential to Start is met. Differential to Start is met when the Discharge Temperature Active is greater than the Discharge Cooling Setpoint Active OR Discharge Temp Control Cooling Target plus the Differential to Start adjustable setpoint, 5°F.

Differential to Stop will stop the last compressor and shut down the unit. Differential to Stop is met when the Discharge Temperature Active is less than the minimum of either Discharge Cooling Setpoint Active or Discharge Temp Control Cooling Target minus the Differential to Stop adjustable setpoint, 5°F.

Differential to Start / Stop has priority over Rapid Restart.

Remote Setpoint

Control will support a remote setpoint input that will allow a user to change the discharge cooling setpoint for Supply Air VAV and EVP system control. The remote setpoint will be set with a 2K potentiometer (supplied by others) that is located within the space and wired back to the control box.



Operating Principles

This will allow users the ability to adjust their setpoint remotely. The remote setpoint range is 10°F – 90°F.

The potentiometer will be wired into a LLID and set up as a resistance input. The resistance is converted to a setpoint. If the input is powered up without a resistance, control assumes the input is not used.

Table 26. Resistance curve

Ohms	Temperature (°F)
13.25	95 ^(a)
110.6	90
207.95	85
305.3	80
402.65	75
500	70
597.35	65
694.7	60
792.05	55
889.4	50
986.75	45
1084.1	40
1181.45	35
1278.8	30
1376.15	25

Table 26. Resistance curve (continued)

Ohms	Temperature (°F)
1473.5	20
1570.85	15
1668.2	10
1765.55	5 ^(a)

^(a) Out of range

Adaptive Control

Adaptive Control™ is a set of algorithms that pre-empt potential equipment disruptions during rapidly changing conditions providing consistent equipment performance and building comfort.

Compressor reliability is a large part of **Adaptive Control**. Symbio™ 800 control will keep compressor(s) operating within their operating envelope. Compressor protections typically involve reducing, if not completely removing, one or more compressors from operation on a given refrigeration circuit. There are two types of protections:

- Lockouts which are associated with diagnostics and the diagnostic is persisted until human intervention or significant unit mode change occurs.
- Limits and Inhibits which are typically temporary, self-correcting, and typically do not involve a diagnostic.

Figure 57. Compressor operating envelope

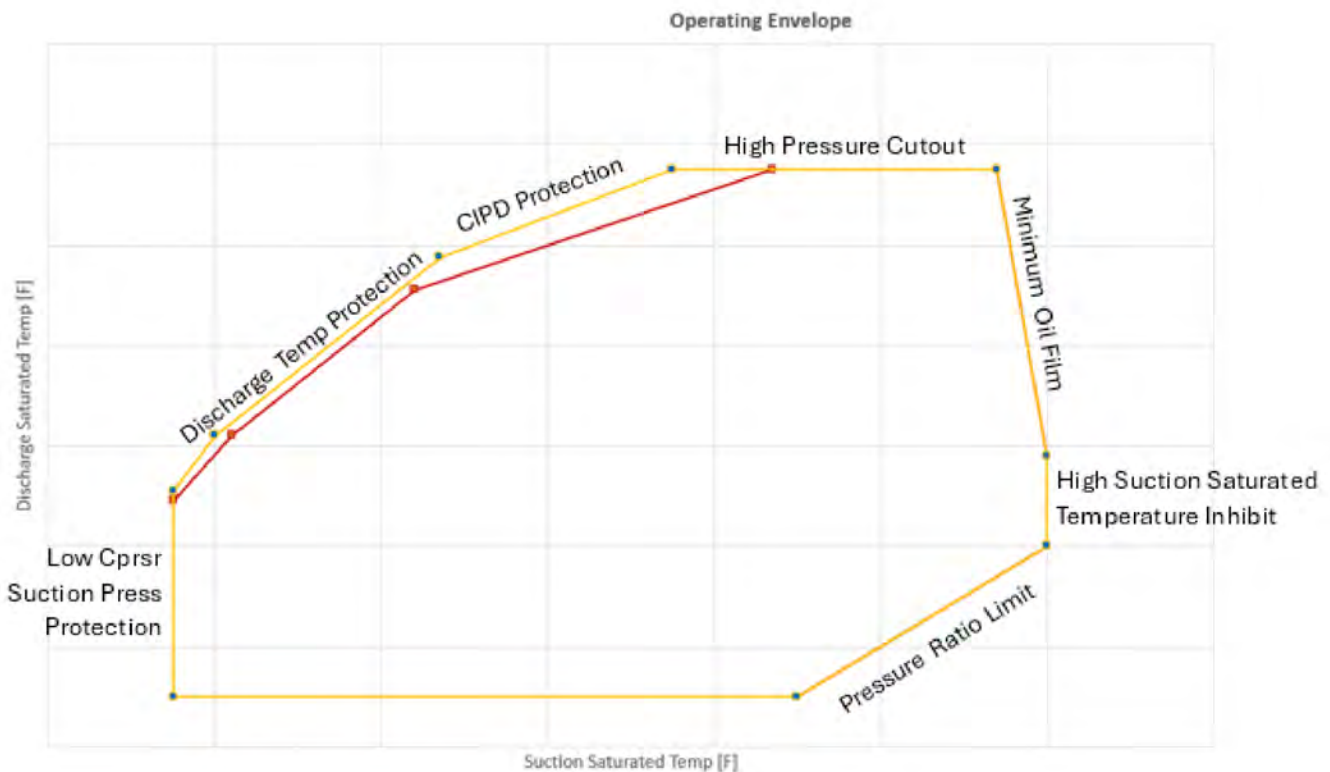

Compressor Discharge Pressure Limit (High Pressure Cutout)

Compressor Discharge Pressure Limit is a control feature of **Adaptive Control™**. This feature prevents a circuit shutdown when the discharge pressure approaches the high pressure cutout switch setting by decreasing compressor capacity. This is done by staging off fixed speed compressors on circuits with high discharge pressure. This feature provides maximum capacity while preventing a high pressure cutout. The discharge pressure limit is based on the discharge pressure percentage relative to the high-pressure cutout setting. This limit is active when the circuit is running. If the discharge pressure limit is preventing loading, holding, or forcing unloading, an indication will be made to the user interface.

Note: *The discharge pressure limit function assumes that all available condenser fans are running and limiting compressor capacity is the only option left.*

High Suction Saturated Temperature Inhibit and Minimum Oil Film

High Suction Saturated Temperature Inhibit and Minimum Oil Film is a control feature of **Adaptive Control™**. This circuit-level feature applies when the suction saturated temperature exceeds the compressor operating threshold limit for suction saturated temperature. The inhibit control action de-energizes the circuit when the suction saturated

temperature exceeds the operating threshold design limit. This feature is not active during circuit startup (five minute startup ignore time).

Condenser Fan Control

Head Pressure Control is a control feature of **Adaptive Control™**. The refrigeration system uses condenser fan control to maintain the compressor discharge pressure of operating compressors on a given circuit to desirable levels. Discharge pressure, suction pressure, and outdoor air temperature sensors are used to provide the control signals. As the pressure of the condenser section increases more, stages of fan capacity are energized to prevent excessive high pressure that could open the High Pressure Cutout switch causing nuisance trips of the refrigeration circuit.

Condenser fan capacity is reduced to prevent excessive low pressures that could cause low compressor pressure ratio and disrupt refrigeration conditions. A unit can have up to two refrigeration systems (circuits) that are completely isolated from each other and are controlled independent from each other.

Low Ambient Operation uses a modulating damper installed over the first condenser fan (Stage 1 fan). Low ambient damper will modulate between 0-100% (adjustable 2-10V by default), 0% (2V) closed, 100% (10V) open.



Operating Principles

Table 27. Condenser fan staging and low ambient damper control

Unit Tons	#	# Fans	Condenser Fan Staging					
	Ckts	per Ckt	(Damper Control on Fan 2M6 and 2M9)					
			Stage 1	Stage 2	Stage 3	Stage 4	Stage 5	Stage 6
20	1	2	Fan 2M6 ON (Damper Modulates)	Fans 2M6, 2M7 ON (Damper Modulates)				
25	1	3	Fan 2M6 ON (Damper Modulates)	Fans 2M6, 2M7 ON (Damper Modulates)	Fans 2M6, 2M7, 2M8 ON (Damper 100% open)			
30	1	3	Fan 2M6 ON (Damper Modulates)	Fans 2M6, 2M7 ON (Damper Modulates)	Fans 2M6, 2M7, 2M8 ON (Damper 100% open)			
40	2	2	Fan 2M6 ON (Damper Modulates)	Fans 2M6, 2M7 ON (Damper Modulates)				
50	2	3	Fan 2M6 ON (Damper Modulates)	Fans 2M6, 2M7 ON (Damper Modulates)	Fans 2M6, 2M7, 2M8 ON (Damper 100% open)			
60	2	3	Fan 2M6 ON (Damper Modulates)	Fans 2M6, 2M7 ON (Damper Modulates)	Fans 2M6, 2M7, 2M8 ON (Damper 100% open)			
80	2	4	Fan 2M6 ON (Damper Modulates)	Fans 2M6, 2M7 ON (Damper Modulates)	Fans 2M6, 2M7, 2M8 ON (Damper Modulates)	Fans 2M6, 2M7, 2M8, 2M22 ON (Damper 100% open)		
100	2	6	Fan 2M6 ON (Damper Modulates)	Fans 2M6, 2M7 ON (Damper Modulates)	Fans 2M6, 2M8, 2M21 ON (Damper Modulates)	Fans 2M6, 2M7, 2M8, 2M21 ON (Damper Modulates)	Fans 2M6, 2M8, 2M21, 2M22, 2M23 ON (Damper at 100%)	Fans 2M6, 2M7, 2M8, 2M21, 2M22, 2M23 ON (Damper 100% open)
120	2	6	Fan 2M6 ON (Damper Modulates)	Fans 2M6, 2M7 ON (Damper Modulates)	Fans 2M6, 2M8, 2M21 ON (Damper Modulates)	Fans 2M6, 2M7, 2M8, 2M21 ON (Damper Modulates)	Fans 2M6, 2M8, 2M21, 2M22, 2M23 ON (Damper 100% open)	Fans 2M6, 2M7, 2M8, 2M21, 2M22, 2M23 ON (Damper 100% open)

Note: Circuit 1 condenser fan reference designators shown. For circuit 2, replace 2M6 with 2M9, 2M7 with 2M10, 2M8 with 2M11, 2M21 with 2M24, 2M22 with 2M25, and 2M23 with 2M26.

Low Ambient Dampers

Low Ambient Dampers are available as a factory installed option or can be field installed. Dampers are used to extend the operation of these units from the standard operational temperatures to a minimum of 0°F without hot gas bypass or 10°F with hot gas bypass. (These values apply when wind speed across the condenser coil is less than 5 mph.). If typical wind speeds are higher than 5 mph., a wind screen around the unit may be required. By

restricting the airflow across the condenser coils, saturated condensing temperatures can be maintained as the ambient temperatures change. The low ambient damper actuator controls damper modulation for each refrigerant circuit in response to saturated condensing temperature.

Low Compressor Suction Pressure Protection

Low Compressor Suction Pressure Protection is a control feature of **Adaptive Control™**. The Low Suction Pressure diagnostic, Start Inhibited by Low Suction Pressure, and Low Compressor Suction Pressure Limit work together to prevent damage to compressors and suction cooled compressor motors operating with little or no refrigerant mass flow. Start Inhibited by Low Suction Pressure and Low Compressor Suction Pressure Limit work together to reduce the likelihood of Low Suction Pressure diagnostic.

Low Compressor Suction Pressure Cutout

The Low Compressor Suction Pressure Protection and Avoidance operates relative to two per-circuit threshold values, Low Compressor Suction Pressure Cutout Startup, and Low Compressor Suction Pressure Cutout Normal.

Table 28. Low compressor suction pressure cutout

Compressor Type	Compressor XY Cutout Startup	Compressor XY Cutout Normal
Trane CSHD (R-410A) Trane CSHN (R-410A)	22.0 psia	36.5 psia
Trane CSHE (R-454B) Trane CSHP (R-454B)	22.0 psia	36.5 psia
Copeland YA (R-454B) Copeland YAS (R-454B)	69.7 psia	69.7 psia

Start Inhibited by Low Suction Pressure

Start Inhibited by Low Suction Pressure inhibits the circuit from starting when low compressor suction pressure exists but will not shut down a circuit that is already running. When the function is in the active state, the circuit is prevented from operating (locked out). The function will transition from Inactive to Active if the circuit is not running and Compressor Suction Refrigerant Pressure is less than 1.2 times Low Compressor Suction Pressure Cutout Normal. The function will transition from Active to Inactive if Compressor Suction Refrigerant Pressure is greater than 1.25 times Low Compressor Suction Pressure Cutout Normal.

Low Compressor Suction Pressure Limit

Low Compressor Suction Pressure Limit limits the addition of circuit capacity any time the circuit is running, and Compressor Suction Refrigerant Pressure is less than 1.4 times the Low Compressor Suction Pressure Cutout Normal.

Low Suction Pressure

Low Suction Pressure diagnostic protects against an inadvertent compressor start when the system is in a vacuum (such as can be produced during service procedures). This protection also minimizes compressor failures and extremely inefficient operation due to total charge loss. The Low Suction Pressure diagnostic shuts down the affected circuit, if already running, when the circuit's Compressor Suction Refrigerant Pressure measurement drops below a factory determined pressure threshold value for normal operation (normal threshold value). Then the circuit is not running, and for a period (in seconds, see bullet points below) immediately after the circuit starts running, the effective start-up pressure threshold is lower than the normal threshold value. These values are dependent on unit model.

- Compressor Discharge Refrigerant Saturated Temperature < 20°F, Reduced Threshold Time = 170 seconds.
- Compressor Discharge Refrigerant Saturated Temperature > 40°F, Reduced Threshold Time = 0 seconds.
- Compressor Discharge Refrigerant Saturated Temperature is between 20°F and 40°F, Reduced Threshold Time is linearly interpolated between 170 and 0 seconds.

Compressor Discharge Temperature Protection

Compressor Discharge Temperature Protection is a control feature of **Adaptive Control™**. The compressor discharge temperature is estimated by software for all the units. The estimated algorithm operates on a two second calculation interval. The inputs for this estimation include saturated compressor discharge temperature derived from discharge pressure, saturated suction temperature derived from suction pressure, and suction temperature provided by a suction temperature sensor LLID on each circuit. All sensor inputs must use the latest possible value at each control cycle.

If the estimated compressor discharge temperature exceeds the compressor discharge temperature unload setpoint, a circuit operating above minimum capacity is forced to unload to reduce the compressor discharge temperature.

If the estimated compressor discharge temperature exceeds the compressor discharge temperature hold setpoint, the circuit is prevented from loading in response for additional capacity.

If the estimated compressor discharge temperature is less than the compressor discharge temperature hold setpoint, the circuit is allowed to load in response for additional capacity.

If the estimated compressor discharge temperature exceeds the compressor discharge temperature trip setpoint a diagnostic triggers and immediately shut down the circuit. The diagnostic automatically clears 10 minutes

Operating Principles

after first generation. On the 5th occurrence within 210 consecutive minutes the circuit will be locked out.

Figure 58. Compressor discharge temperature protection

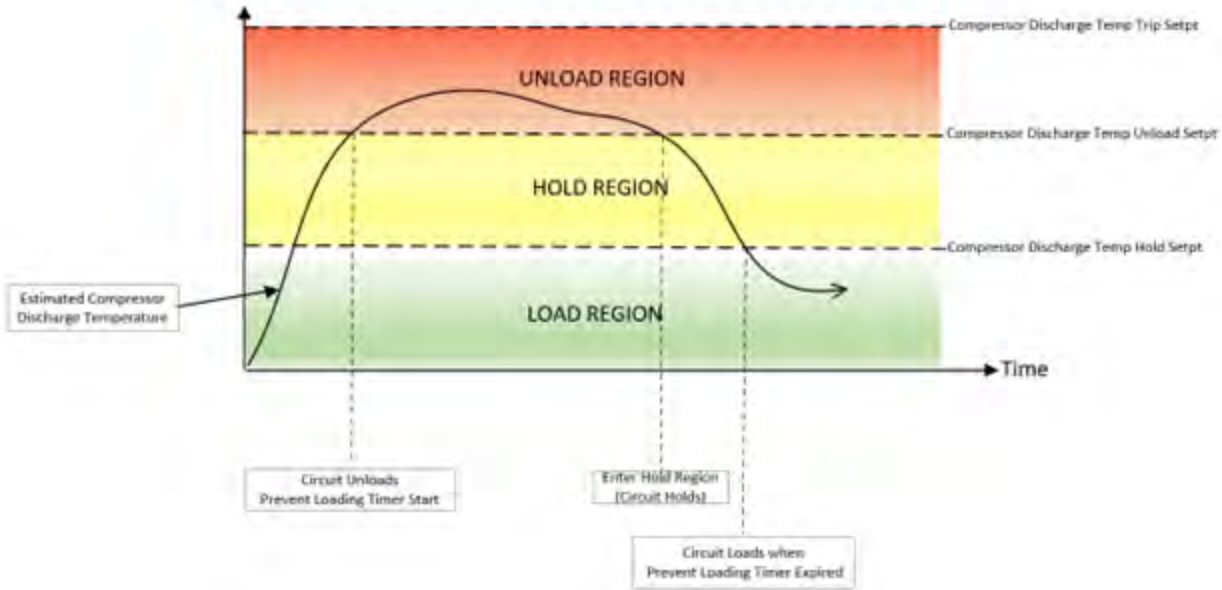

Compressor Involute Pressure Differential Protection (CIPD Protection)

Compressor Involute Pressure Differential Protection is a control feature of **Adaptive Control™**. Scroll compressors have a limitation on the pressure difference between the opposite sides of the involute tip near the center of the scroll. High values of compressor involute pressure differential may cause compressor fatigue. Its associated limit will attempt to allow the unit to run safely at partial capacity without tripping the circuit on a diagnostic. The compressor must be restricted from running in this condition. When this function is active, an indication is made to the user interface. Depending on severity, both instant and delayed shutdowns are possible. Shutdowns may be temporary or require a manual reset.

Figure 59. Scroll compressor involute

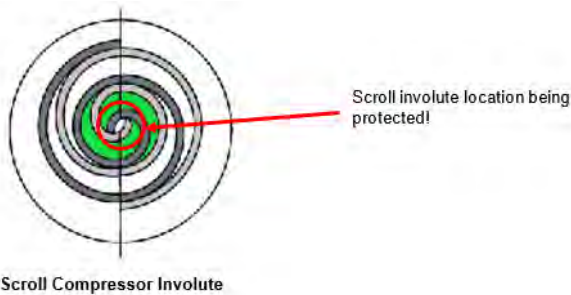

Two Stage Compressor Discharge Saturated Temperature Limit

Two Stage Compressor Discharge Saturated Temperature Limit is a control feature of **Adaptive Control™** for manifolded compressor sets with Two-stage compressors. This circuit and compressor level feature applies when the discharge saturated temperature approaches or exceeds the compressor operating map limits for high discharge saturated temperature. Limit control action modifies the normal staging control to adjust capacity by holding or applying the two-stage compressor load solenoid command or holding or subtracting a circuit staging command. The two-stage compressor limit is a "Load" limit. The circuit limit is an "Unload" limit.

The two-stage compressor "Load" limit sequence is also applied to the oil management staging limit control. This limit activates when the discharge saturated temperature exceeds oil management staging limit setpoint.

Figure 60. Two-stage compressor discharge saturated temperature limit

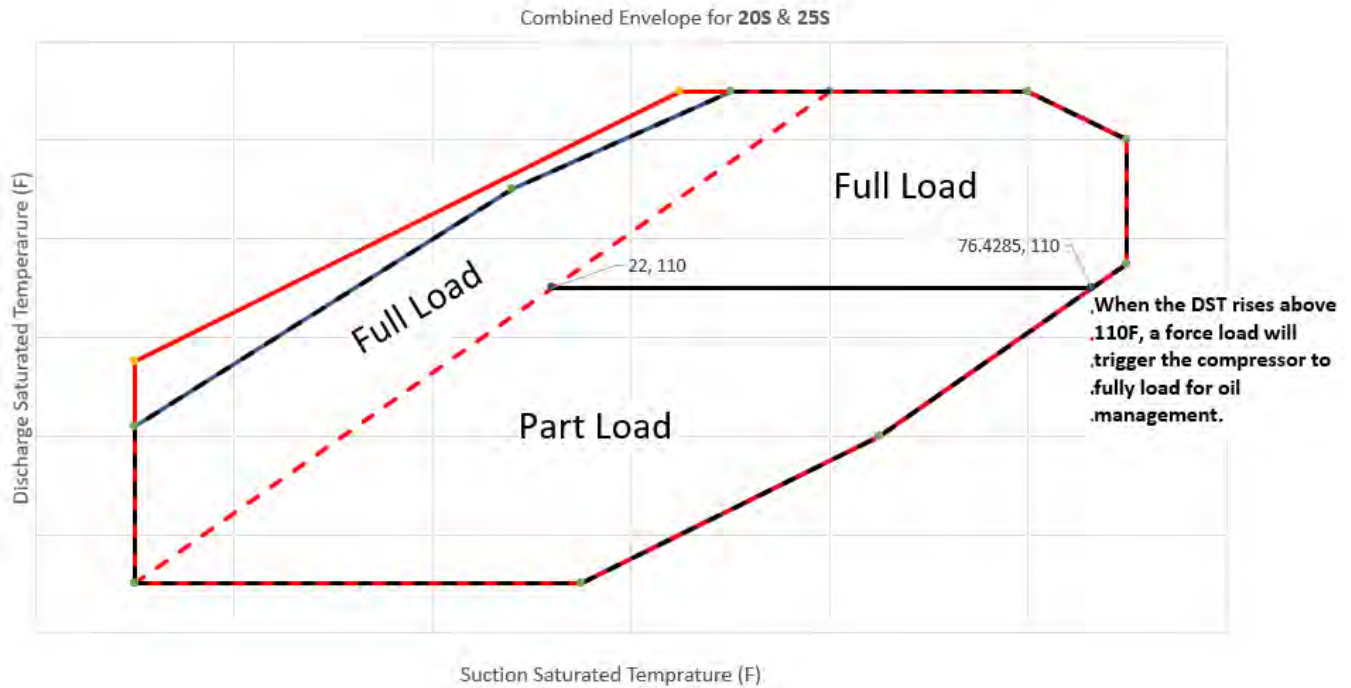

Low Ambient Lockout

Low Ambient Lockout prevents compressor operation when outdoor air temperature falls below an adjustable low ambient lockout setpoint. The low ambient lockout setpoint range and default value is dependent on low ambient damper configuration (installed / not installed). If the low

ambient damper is not installed, the unit is considered a Standard Ambient unit. If low ambient damper is installed, the unit is considered a Low Ambient unit.

When the outdoor air temperature rises above the low ambient lockout setpoint + 5°F the lockout will be removed, and the compressors will be available.

Table 29. Low ambient lockout setpoint range and default values

Unit Performance	Nominal Capacity	Hot Gas Bypass	Low Ambient Damper	Condenser Fan Control Type	Low Ambient Lockout Setpoint
Standard	All	Installed / Not Installed	Not Installed	All Fixed Speed	45 to 80°F (50 F)
		Not Installed	Installed	All Fixed Speed	-20 to 80°F (0 F)
		Installed	Installed	All Fixed Speed	-20 to 80°F (10 F)

Oil Management Protection

Trio manifolded compressors on single circuit units require an additional level of protection for the fixed speed compressor installed in the “A” position. When the “A” compressor has been energized and an additional compressor has been commanded on, a 30-minute timer is started. When the 30-minute timer has expired, the “A” compressor is de-energized for thirty seconds. At the end of the 30 seconds, the compressor is released to normal control. The timer is reset at the end of oil management cycle.

Note: The 30-minute timer begins after the Min on Time. So, if compressor B or C is already on when A starts the first cycle off will occur 30 mins + Min on Time after A starts.

Compressor Staging and Timers

Compressor operation is required to meet discharge and/or space cooling demands. As the cooling request increases, additional stages are added to meet the demand. As cooling request decreases, compressor stages are reduced. There are critical time delays imposed between stages to reduce compressor short cycling.

“No Control” system control stage compressors based on their perspective binary input being closed. There is not a prescribed staging sequence.

Minimum OFF Time, Minimum ON Time, and Interstage delay are critical time delays associated with compressor staging control to optimize refrigeration system performance.



Operating Principles

Minimum OFF Time

For each compressor, when the compressor has been turned OFF for any reason, a timer is started for that compressor(s). The compressor(s) is not allowed to be turned back ON until their timer has expired.

Minimum ON Time

Once a compressor has been turned ON a timer is started for that compressor. The compressor is not allowed to be turned back OFF until its timer has expired. A normal stop request (user interface Stop, normal shutdown diagnostic) honors the Minimum ON Time and keep the compressor on until the timer expires.

Note: Any Immediate stop request or Immediate Shutdown diagnostic overrides any minimum on time and shut the compressor off immediately.

Inter-stage Time

For normal unit operation the timing between stages is maintained at a minimum of a fixed Interstage Delay Time. The compressor control algorithm may request staging to occur beyond three minutes, but the time span from one stage turning ON(OFF) until the next compressor stage turning ON(OFF) is no less than the three minute interstage time. Rapid Restart and manual compressor control can override this time. .

Note: For a "No Control" system control unit, the interstage delay timer is reduced to 60 seconds. If all compressors are requested on at the same time, each compressor turns on at 60 second intervals. Once on, if turned off, the three minute minimum OFF timer is honored

Alternate Staging

When one or more compressors are unavailable due to Lockouts and Inhibits, an alternate staging sequence is determined from a rule-based algorithm which selects the best next stage from the available compressors. Double Swaps are not performed during Alternate Staging Sequence. While in alternate staging, staging up, staging down will likely be slightly different than a standard staging table.

Double Swaps

When staging up or down, one compressor will turn ON and for the same stage another compressor will turn OFF.

Staging Up

On single circuit units, two circuit units with neither circuit active, or two circuit units with both circuits active, the smallest available compressor is selected to start. On two circuit units with one circuit active, the smallest available compressor on the non-active circuit is chosen to start. If none are available on the non-active circuit, the next smallest available compressor on the active circuit is chosen to start.

Staging Down

On single circuit units or two circuit units with one circuit running, the largest running compressor is chosen to stop.

On two circuit units with both circuits active, the largest running compressor that will not cause a circuit to stop is chosen. If there is only one compressor running per circuit, the larger of the two compressors is chosen to stop.

Transition out of Alternate Staging and into Normal Staging

When all compressors are available on the next request to add or subtract, the current state is evaluated against the normal staging table. If a match is found, the next staging decision is made following the normal staging rules. If the normal table does not contain a match for the current state, then the Alternate Staging sequences is used to process the command, and the cycle continues until a match has been found.

Transition out of Alternate Staging and into Normal Staging with Balanced Compressor Staging Enabled

Balanced Compressor Staging is a feature setting, when enabled balanced staging rules are used to process the next staging request.

Balanced Compressor Staging

Balanced Compressor Staging function is a user-defined option for fixed-speed compressor units with Supply Air VAV or EVP system control. Balanced compressor staging is not available on units with two-stage compressors and/or HGBP. Double Swaps are not performed during Balanced Compressor Staging.

To perform compressor wear balancing, the controller keeps track of each installed compressors number of starts and run-time. The controller uses this information to equalize wear across all compressors installed in the unit. The Balanced Compressor Staging function can be Enabled or Disabled at the user interface. When disabled, compressor staging follows the Normal Staging Sequence.

Single Circuit Units

The lowest wear compressor starts first. Subsequent stage increases start the next lowest wear compressor. The final stage increase starts the last compressor. Each stage decrease de-energizes the highest wear compressor first.

Dual Circuit Units

The lowest wear compressor from either circuit starts first. The second stage increase starts the next lowest wear compressor from the "Off" circuit. Subsequent stage increase requests starts the lowest wear compressor available. Stage decreases with both circuits active, the highest wear running compressor that will not cause a circuit to stop will be chosen. If there is only one compressor running per circuit, the compressor with a higher wear calculation is chosen to stop.

Ties

If multiple compressors with equal wear are available for the next stage, the smallest compressor starts. The largest compressor stops. If there is also a compressor size tie, there is no requirement to break ties farther. Control selects one of the "tied" compressors to stage.

Note: “No Control” system control units use Ties when multiple stages are requested simultaneously.

Loss of Charge Detection

Unit may experience leakage of refrigerant charge at any point during its life. Moderate refrigerant loss negatively affects capacity and reduces suction saturated temperatures. However, excessive refrigerant loss may lead to compressor damage. The goal is to detect the condition and then either alert the user or shut down the circuit depending on the severity of the loss of charge. Loss of Charge Detection is a per circuit feature.

Loss of charge has two features: \ Loss of Charge Detection Warning and Loss of Charge Detection Lockout. The distinction between warning and a lockout is based on the severity of loss of charge.

Loss of Charge Detection Warning

Loss of Charge Detection Warning is a diagnostic that triggers when suction superheat is more than the suction superheat warning threshold for a consecutive 10 minutes.

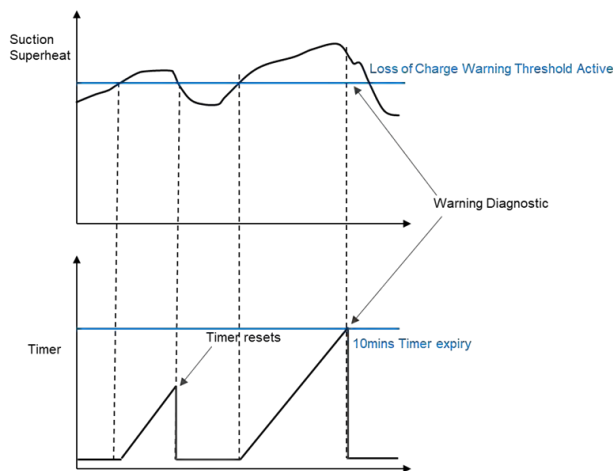

Loss of Charge Detection Lockout

Loss of Charge Detection Lockout is a diagnostic that triggers when the suction superheat is greater than the suction superheat lockout threshold for a consecutive 10 minutes.

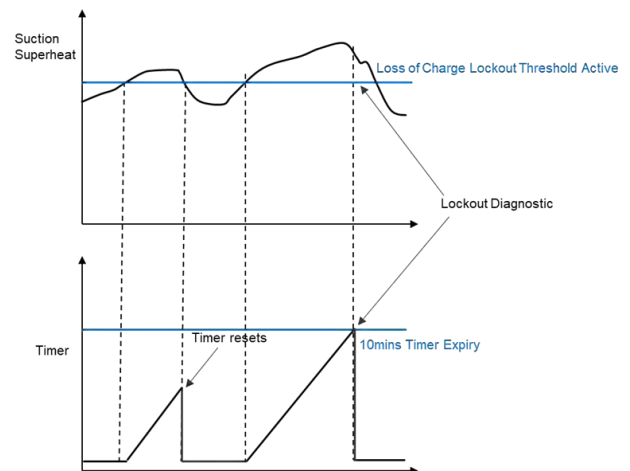

Frost Protection

As frost builds on the evaporator coil, the thermal resistance increases, and the airflow is restricted. The maldistribution in the coil can also cause instabilities in Superheat Control. Frost Protection limits or inhibits capacity to remove the frost and allow the unit to run more efficiently. Once the frost is removed, the unit returns to normal operation.

No System Control and Supply Air VAV Control uses two methods of frost protection: Coil Frost Protection through Symbio™ 800 control and Froststat™ Frost Protection.

Coil Frost Protection

Coil Frost Protection is a control feature that is active anytime one or more compressors on a circuit are running. The feature uses per circuit compressor suction pressure transducer and converts the measured pressure to a suction saturated temperature. This protection limits loading or unload the circuit capacity to minimize evaporator coil frosting conditions.

Frost protection begins if the saturated suction temperature drops below Evap Coil Frost Threshold plus the Evap Coil Frost Delta but above the Evap Coil Frost Threshold as defined by the HOLD REGION in Figure 61, p. 88, Coil Frost Protection Staging Limit. In the Hold Region the circuit prevents any additional loading. This region is intended to minimize a frost potential and prevent any additional capacity that may worsen the frost potential.

Any time the saturated suction temperature drops below the Evap Coil Frost Threshold defined by the UNLOAD REGION, as shown in Figure 61, p. 88, Coil Frost Protection Staging Limit. In the Unload Region, the circuit starts un-staging compressor(s). By un-staging compressors the saturated suction temperature increases. Un-staging last stage leads to an inactive circuit and result in a circuit run inhibit.

Once the frost is removed, the unit is returned to normal operation.

To avoid nuisance trips at startup, an ignore time delay is applied. The delay time is variable and is based on outdoor air temperature.

Figure 61. Coil frost protection staging limit

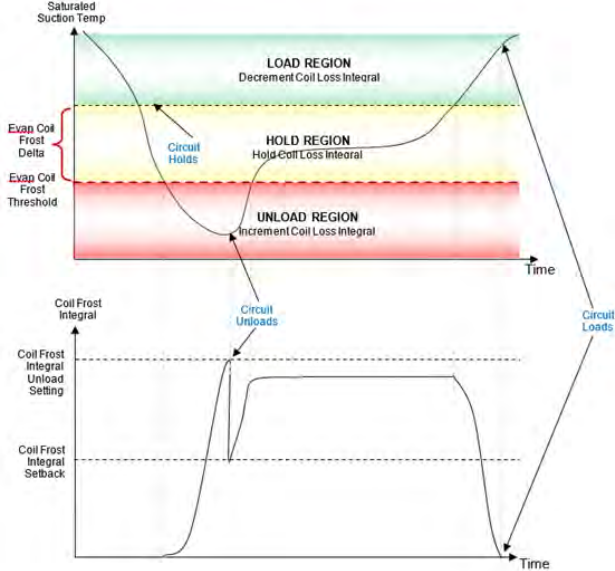

Frostat Frost Protection

The Frostat™ thermostat switch is normally closed, opens as temperature falls below 30°F + 5°F and closes when the temperature rises above 40°F + 5°F. The thermostat is mounted directly to the surface of the suction line near the evaporator and wired to a LLID in the main control panel. When the switch opens, the circuit will deenergize.

Freeze Protections - EVP System Control

Freeze protections specific to EVP system control to minimize the risk of freeze damage to the Brazed Plate Heat Exchanger (BPHE) include Freezestat™, Low Water Temperature Protection, Low Refrigerant Temperature Protection, and Low Suction Pressure Limit.

Freezestat

Freezestat™ temperature control is installed in the EVP remote panel close to the BPHE. Freezestat protection uses a bulbwell that is installed in the leaving water outlet piping as close to the BPHE as possible, upstream of the discharge temperature sensor. A remote sensing bulb is installed into the bulbwell which measures the water temperature. The remote sensing bulb has 20 feet of capillary tube that routes to the temperature control.

The temperature control is a switch that opens/closes a set of contacts when the temperature gets to a certain level. This switch is wired to a Dual High Voltage Binary Input LLID. The contacts are normally closed, and opens as the water temperature falls below the Freezestat temperature control setpoint (20°F – 80°F).

After Freezestat becomes active, the manual reset lever on the temperature control must be manually reset by a field technician. The field technician knows that the Freezestat device has been active due to the Freezestat Active diagnostic.

If under 15°F, user will need their own freeze protection and jumper the Freezestat input.

Low Evaporator Water Temperature Protection

Low Evaporator Water Temperature Protection provides BPHE freeze protection based on the discharge water temperature relative to the low evaporator water temperature cutout adjustable setting, 38°F. This is a unit shutdown with an auto-reset diagnostic when discharge water temperature approaches the water/glycol solution freezing point. When the discharge water temperature exceeds the low evaporator water temperature cutout, the unit is allowed to restart.

Low Refrigerant Temperature Protection

Low Refrigerant Temperature Protection provides BPHE freeze protection based on the suction saturated temperature. If the suction saturated temperature falls below the low refrigerant temperature cutout adjustable setting, 26°F, the circuit is shut down.

Note: The Low Evaporator Temperature Cutout and Low Water Temperature Cutout should be adjusted for different glycol levels. Contact Trane Technical Support for adjustment setting. Additional glycol beyond the recommendation will adversely affect unit performance. Unit efficiency and saturated evaporator temperature could be reduced. For some operating conditions, this effect can be significant. If additional glycol is used, then use the actual percent glycol to establish the Low Refrigerant Cutout setpoint.

Low Suction Pressure Limit

Low Suction Pressure Limit is a circuit level limit that holds or reduces the capacity of a refrigeration circuit when suction pressure approaches low refrigerant temperature cutout. The low suction pressure leads to a low suction saturated temperature, which can result in localized freezing of water within the evaporator. To minimize localized freezing, when the condition exists, the compressors are prevented from staging up, or are staged off, if necessary. With pressure transducers, it is possible to unload one stage of capacity at a time when suction pressure approaches the cutout setting.

The most common cause of low suction pressure occurs when the thermal expansion valve (TXV) is fully open, and the differential pressure is not high enough to push the required amount of refrigerant through the valve. This causes refrigerant to back up into the condenser and the system tries to stabilize by lowering the suction pressure. Because the TXV flow capacity is proportional to the square root of differential pressure, doubling the refrigerant flow by staging on a second compressor requires four

times the minimum differential pressure. In some cases, it is not possible to run above the circuit's minimum capacity. Trying to load another compressor causes the entire circuit to cycle off on low pressure cutout or low refrigerant temperature cutout. Other scenarios causing low suction pressure include loss of subcooling entering the TXV, usually caused by charge migration or loss of charge.

Load Region

When active, the circuit is allowed to add capacity when any of the following is true:

- The suction pressure has never fallen to, or below, the Hold Pressure Threshold.
- The suction pressure rises above the Hold Region without ever falling to, or below, the Unload Pressure Threshold.

- The suction pressure has exited the Unload Region and has risen above the Hold Pressure Threshold and the discharge pressure has exceeded the calculated Minimum Discharge Pressure.

Hold Region

When the circuit is running at or above its minimum capacity, prevent the circuit from loading (hold) when the suction pressure is equal to or less than the Hold Pressure Threshold and above the Unload Pressure Threshold.

Unload Region

If the suction pressure is less than the Unload Pressure Threshold and the circuit is at minimum capacity, circuit loading is prevented (hold); otherwise, if the circuit is greater than its minimum capacity, the circuit capacity should be reduced (unload).

Figure 62. Low suction pressure limit

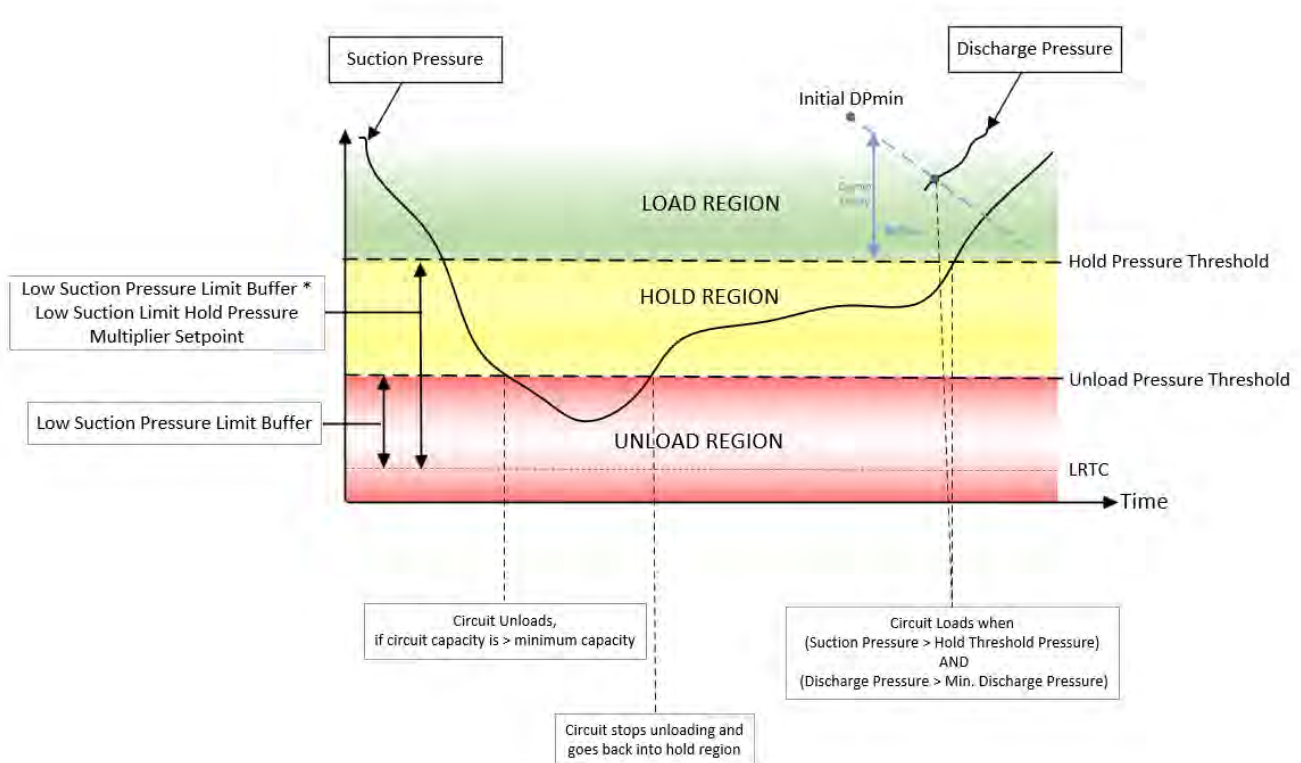

Hot Gas Bypass (Coil Frost Protection)

When Hot Gas Bypass (HGBP) is installed, the control energizes the HGBP solenoid valve and regulates it based on the preset pressure setpoint (for R-454B 96.5 + 3 PSIG; for R-410A 115 + 3 PSIG). The valve diverts hot, high-pressure refrigerant gas from the high side to the low-pressure side of the system, creating a “false load” that prevents low suction pressure and helps avoid coil frost.

The pressure actuated HGBP valve is external to the controller and its operation is transparent to the normal staging control. The HGBP valve regulates evaporator

pressure by opening as suction pressure decreases, to maintain a desired minimum evaporating pressure regardless of a decrease in evaporator external loading. Hot Gas Bypass is a feature that can be enabled/disabled via the user interface.

The HGBP solenoid valve is spring return closed, meaning that when the solenoid is not energized the valve is closed. This ensures that when the unit does not have power (power loss or transport), the valve is closed. The HGBP solenoid valve is controlled via a relay output. The solenoid is connected to the normally open connection on the relay.

Operating Principles

To open the valve, control closes the relay which energizes the solenoid.

The HGBP solenoid valve energizes when the Suction Saturated Temperature < Hot Gas Bypass Enable Setpoint and deenergizes when the Suction Saturated Temperature > Hot Gas Bypass Enable Setpoint + 2.778°C (37°F). The Hot Gas Bypass Enable Setpoint is adjustable on the user interface. The user can adjust the enable setpoint if the solenoid needs to be energized at different suction saturated temperature than the default value. Symbio™ 800 will only energize or de-energize the solenoid valve. Symbio 800 is unaware if the valve is operating properly.

When the evaporator (suction) pressure is at or above the valve's setpoint, it remains closed. As suction pressure falls below the valve's setpoint, the valve begins to open. The valve continues to open at a rate proportional to the suction pressure drop, thus maintaining evaporator pressure and minimizing coil frost. The solenoid valve is closed when de-energized. The valve's setpoint is adjustable and located on the valve itself.

Note: *Hot Gas Bypass Enable Setpoint default value is approximately 2.2°C (4°F) above the suction saturated temperature equivalent of the valve pressure setpoint.*

Liquid Line Valve Control

Large Split units use thermal expansion valves (TXV) that cannot be commanded closed when the circuit is not running. Therefore, to stop refrigerant migration through the system, a liquid line solenoid valve is used to close off that path of refrigerant flow from the condenser to the evaporator when the circuit is not running.

The Liquid Line Solenoid Valve is spring return closed, meaning that when the solenoid is not energized the valve is closed. This ensures that when the unit does not have power (power loss or transport) that the valve is closed.

The Liquid Line Solenoid Valve is controlled via a relay output. The solenoid is connected to the normally open connection on the relay. To open the valve, control closes the relay which energizes the solenoid.

Activation

Before a circuit commands a compressor on, during circuit prestart, the Liquid Line Relay Enable is Enabled. It must stay enabled during entire time the circuit is running.

Deactivation

When the circuit shuts down and has confirmed all compressors are no longer running, the Liquid Line Relay Enable is Disabled. Under Automatic control, it will remain disabled as long as the circuit is not restarted.

Control Box Ventilation Fan Control

AC Axial Fan is mounted in the control box of 80-120T units. The fan's purpose is to provide air flow across the electrical components in the control box. The ventilation fan turns on when the Outdoor Air Temperature is greater than

the user adjustable Control Box Ventilation Fan Enable Setpoint (105°F). The fan runs continuously until the Outdoor Air Temperature is below Control Box Ventilation Fan Enable Setpoint minus Ctrl Box Ventilation Fan Disable Offset of 10°F.

On the Unit screen of the user interface, Control Box Ventilation Fan Relay provides the user status information on whether the fan is running (On) or not running (Off). While the fan is running, Control Box Ventilation Fan Run Time accumulates until the fan is turned off. When the run time accumulates to 53,000 hours (6 years), a Control Box Ventilation Fan Life diagnostic triggers to provide the user information indicating the fan has entered its end of life cycle.

Figure 63. Control Box Ventilation Fan Relay and Run Time

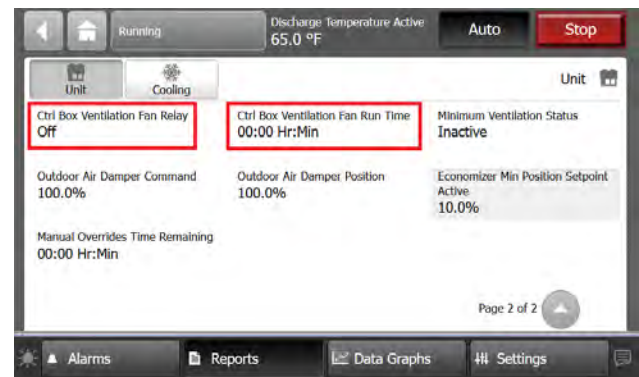

When the fan is field replaced, a Control Box Ventilation Fan Run Time Reset is available to set the accumulated timer back to zero run hours. This reset is available through the user interface through manual control settings.

Figure 64. Control Box Ventilation Fan Run Timer Reset

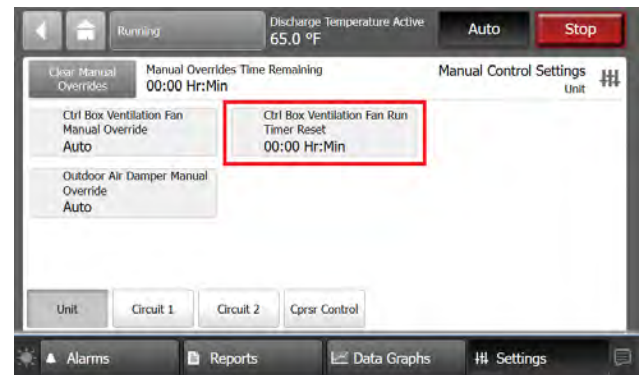

Integrated Economizing

Integrated Economizing only applies to units configured with Supply Air VAV Control and consists of the outdoor air damper, outdoor air damper actuator, and a Hex I/O LLID. Economizing is designed to use the outdoor air damper to provide free cooling for the building when the outdoor air temperature is favorable. The cooling capability of the

outdoor air is determined by comparing the Outdoor Air Temperature against the user adjustable Econ Enable Minimum Outdoor Air Temp Setpoint (60°F). There must be a valid Outdoor Air Temperature sensor.

The customer will have an outdoor air damper installed in the air handler. The outdoor air damper is manipulated with an actuator that typically uses a 2-10VDC which equates to a 0-100% position. Economizing is designed to provide the DC voltage output from a Hex I/O LLID to control the outdoor air damper actuator.

The economizer minimum position can be used to provide minimum ventilation, if required. Economizing drives the outdoor air damper via the outdoor air damper actuator to the Economizer Min Position Setpoint after the fan interlock has been proven.

If the discharge temperature is below the Discharge Cooling Temperature Setpoint, economizing sets the outdoor air damper via the outdoor air damper actuator to the Economizer Min Position Setpoint. The Economizer Min Position Setpoint is honored even if the Economizer is Disabled.

Figure 65. Economizing example

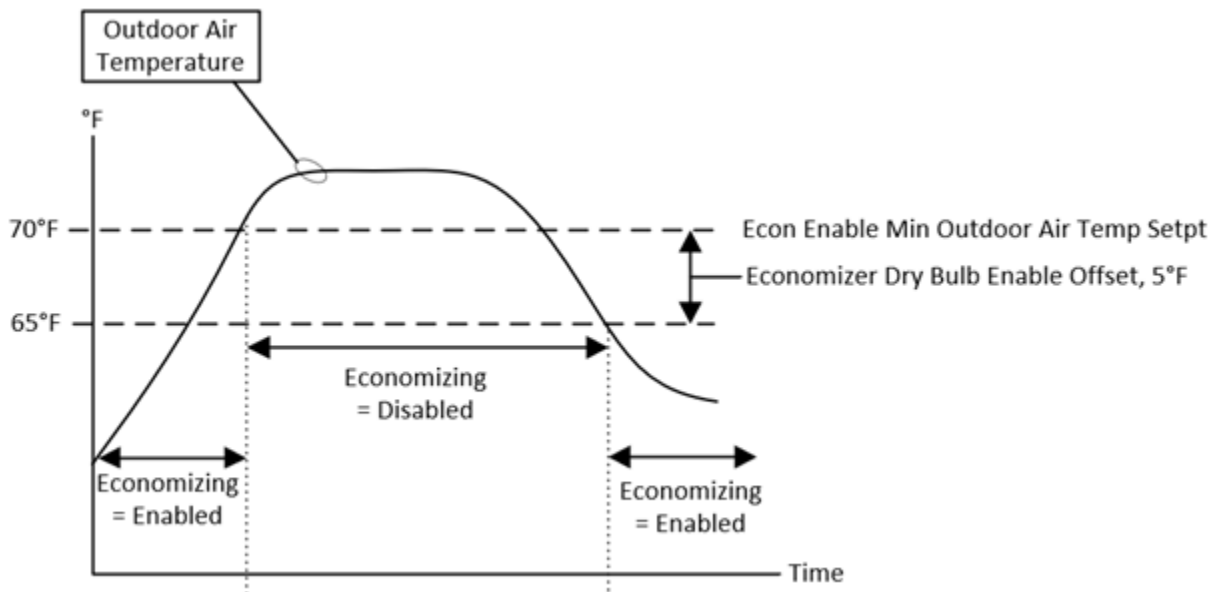
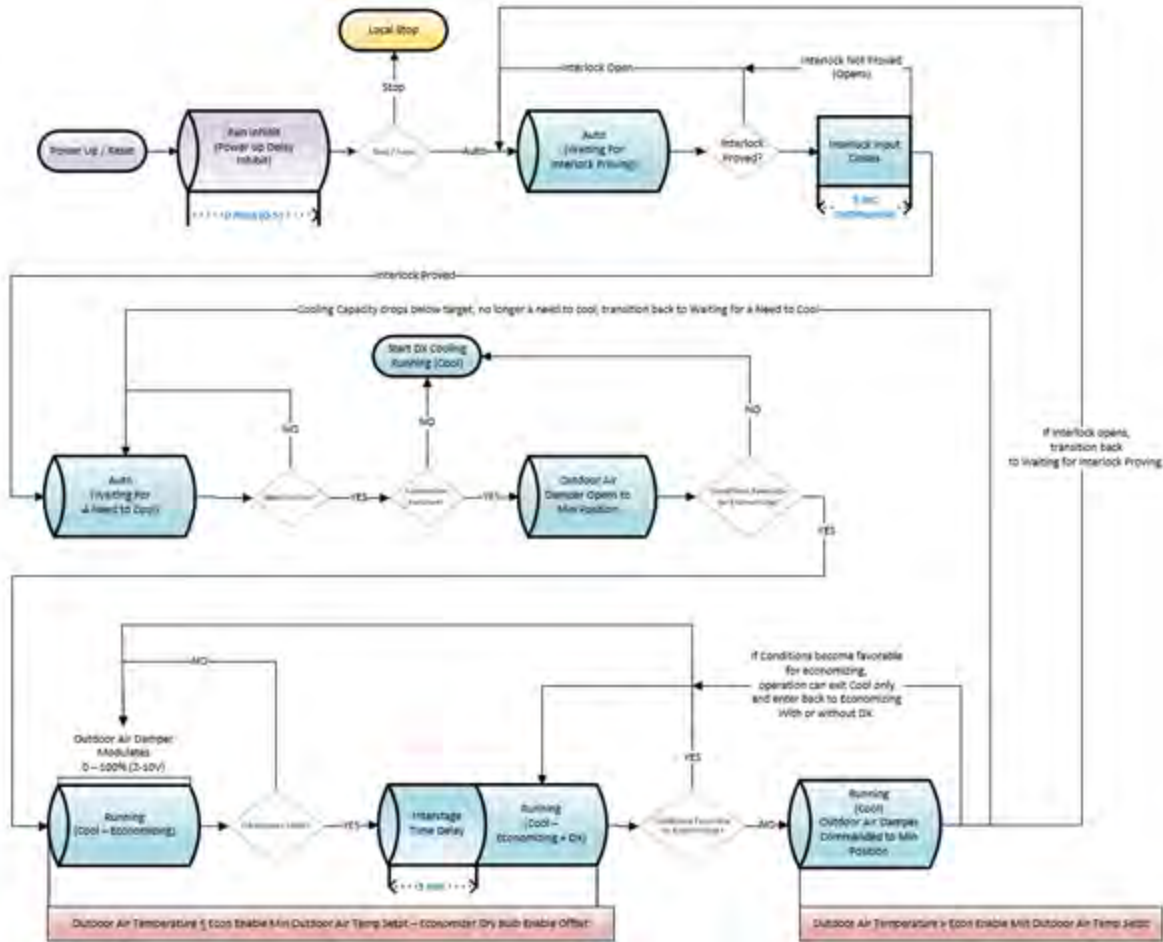

Figure 66. Integrated economizing sequence of operation



Outdoor Air Damper Fault Detection

Air Handlers paired with a RAUK unit uses electro-mechanical actuators to control outdoor air dampers. These actuators are equipped with feedback circuits indicating the actual position of the damper relative to the commanded position. Monitoring this feedback, and comparing to the commanded value, allows the unit controller to determine if the components are working as expected and to call out failure diagnostics if they are not.

Actuator Parameter Settings

There are four parameters with each actuator.

- **Direction** — There are two choices for direction: Direct and Reverse. When set to Direct acting, the actuator's closed/open position is associated with the Minimum Voltage/Maximum Voltage. When set to Reverse acting, the actuator's closed/open position is associated with the Maximum Voltage/Minimum Voltage.
- **Stroke Time** — The stroke time is the amount of time in seconds for the given actuator to stroke through its full capable range when commanded from a fully

closed/open to a fully open/closed position. It is used to update control sequences for a given actuator.

- **Minimum Voltage** — The minimum voltage is the lowest voltage output allowed to the actuator. It is associated with the algorithm request of 0% open (fully closed) if direct acting or 100% open (fully open) for reverse acting.
- **Maximum Voltage** — The maximum voltage is the highest voltage output allowed to the actuator. It is associated with the algorithm request of 100% open (fully open) if direct acting or 0% open (fully closed) for reverse acting.

Rapid Restart

Rapid Restart is a control feature offered on units with Supply Air VAV or EVP System Control. The purpose of rapid restart function is to meet the cooling requirement for applications where the space has a high heat load and requires critical temperature control. A typical application is a data center that has several routers and servers. There are no assumptions about how long the unit has been OFF, so the unit will perform the same startup sequence each occurrence when enabled. The control for Rapid Restart is

very aggressive because the loss of cooling capacity, because a power interruption or extended cooling inhibited time, may cause the space temperature to rise as much as 3 – 4°F per minute. When power restores normally, or by a backup generator, the cooling capacity must be rapidly restored to help get the space under control. After a Rapid Restart, the unit can subsequently manage the load using normal capacity control.

A valid discharge temperature sensor is required, an uninterruptable power supply is not required, and

integrated economizing is not allowed during Rapid Restart operation.

Differential to Start will be met before Rapid Restart will begin. If all other conditions for Rapid Restart are met the unit will wait for Differential to Start indefinitely with a "pending" Rapid Restart.

Differential to Stop is active during Rapid Restart operation and will take priority if conditions are met. When conditions are met, the unit will immediately stop all compressor operation and minimum on timer will not be honored.

Figure 67. Rapid restart sequence of operation

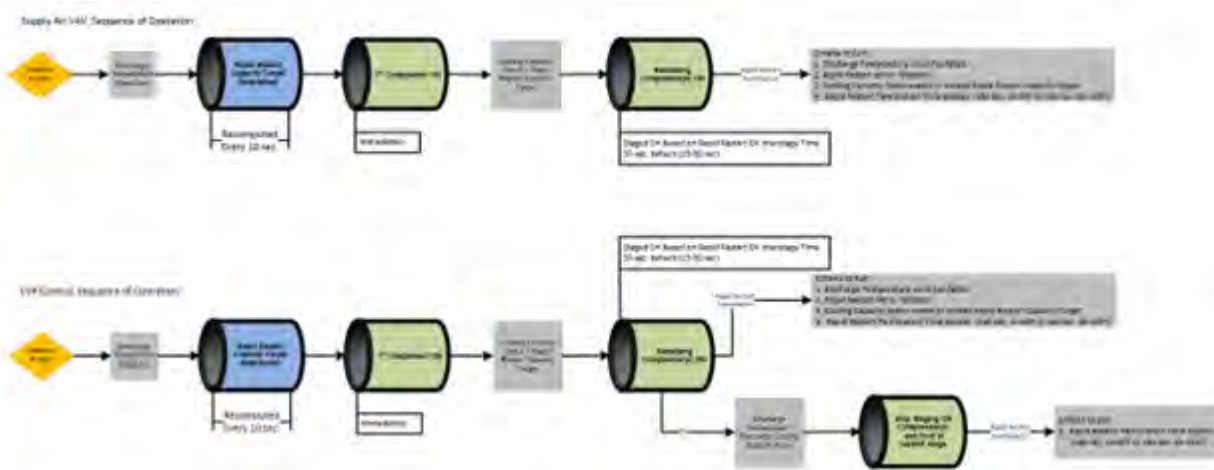

Refrigerant (R-454B) Leak Detection

The condenser unit requires a refrigerant leak detector input. The leak sensor is mounted in the paired air handler unit or mechanical room and hardwired to the customer controls terminal strip on the control panel.

Control shall accept an isolated contact closure input that is monitored by a Symbio™ 800 binary input. Contact closure represents a unit operation request, and contact opening represents mechanical cooling to immediately stop.

Refrigerant Leak Detection mitigation is handled by control in the paired air handler.

Discharge Air Reset

Discharge Reset is a method to save energy by resetting the discharge temperature as cooling building loads

increase and decrease. This is available on Supply Air VAV and EVP system control. When enabled, the controller can independently reset the Discharge Cooling Setpoint based on outdoor air temperature. The new target setpoints are reported as Discharge Cooling Setpoint Status. The user interface display provides settings for the reset temperature range (Outdoor Air) and discharge temperature setpoint reset amount over the specified range.

For example: the discharge temperature cooling setpoint shall increase 5°F over an outdoor temperature range of 90°F to 70°F. If Discharge Air Cooling Setpoint Active is 50°F and Outdoor Air Temperature is 80°F, the reset function calculates and reports Discharge Cooling Setpoint Status = 52.5°F. The controller provides discharge air or water at 52.5°F.

Figure 68. Discharge air reset

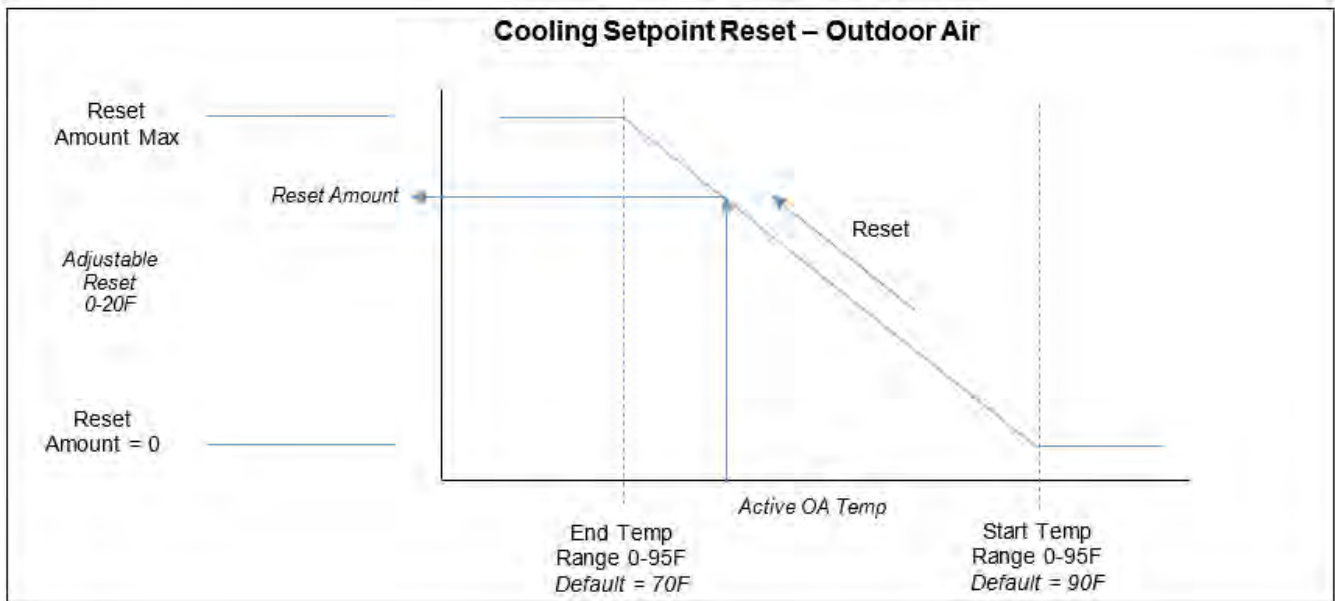

Demand Limit

Cooling Capacity Enable and Demand Limit Request BAS are building automation interface points used to limit DX cooling capacity of the equipment to limit power consumption. Neither limit economizer cooling.

When set to limit, the Demand Limit Setpoint value (0-100%) and Cooling Capacity Enable (0-100%) is applied to the control capacity calculation. The power consumption result depends on number of cooling stages installed and how each stage maps to the capacity calculation (0-100%).

When Cool Lockout Command is not locked, control limits capacity based on active Cooling Capacity Enable or Demand Limit Setpoint. The lowest commanded value is honored. For example:

- Cool Lockout Command is not locked-out.
- Cooling Capacity Enable Default is 60% and Demand Limit Setpoint Default is 40%. DX cooling capacity is limited to 40%.

Operating Modes

The user interface Operating Modes screen provides Unit and Circuit level mode information valuable to understanding the equipment operating state. Each Unit and Circuit mode provide sub-mode information with valuable details to understand active controls and limits that are affecting operation. For more information, refer to the Programming Guide (SS-SVP018*-EN).

Figure 69. Operating Modes

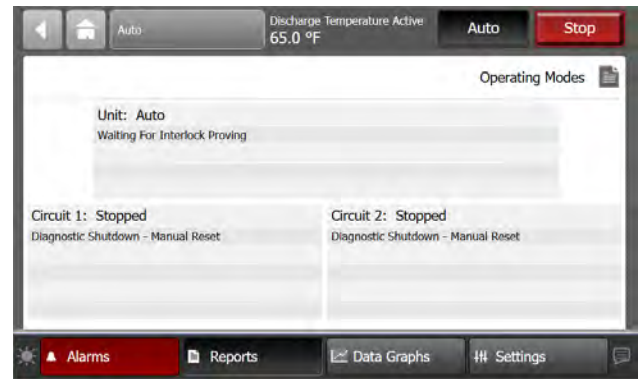

Communication Protocol

BACnet® and Modbus® Building Automation Control Network points are internal to Symbio™ 800 control. There are no additional modules needed if communication protocol is ordered. Refer to BACnet and Modbus integration guides for details on how to integrate the building automation system.

Thermostatic Expansion Valve

The reliability and performance of the refrigeration system is heavily dependent upon proper expansion valve adjustment. Therefore, the importance of maintaining the proper superheat cannot be over emphasized. See through in “Start-Up,” p. 99 for proper superheat adjustment. Accurate measurements of superheat will provide the following information.

- Effectiveness of expansion valve control of refrigerant flow.

- Efficiency of the evaporator coil.
- Amount of protection compressor is receiving against flooding or overheating.

The expected range for superheat is 14°F to 18°F at full load conditions. At part load, expect a properly adjusted expansion valve to control to 8 to 12°F superheat. Systems operating with lower superheat could cause serious compressor damage due to refrigerant floodback.

The outdoor ambient temperature must be between 65°F and 105°F and the relative humidity of the air entering the evaporator must be above 40 percent. When the temperatures are outside of these ranges, measuring the operating pressures can be meaningless.

Compressor Crankcase Heaters

Each compressor is equipped with a crankcase heater. When the compressor is “Off”, the crankcase heater is energized. When the compressor is “On”, the crankcase heater is de-energized. The proper operation of the crankcase heater is important to maintain an elevated compressor oil temperature during the “Off” cycle which reduces the potential for refrigerant to migrate into the compressor oil.

If present during compressor start, liquid refrigerant could damage compressor bearings due to reduced lubrication and eventually could cause compressor mechanical failures.

NOTICE

Compressor Failure!

Failure to follow instruction below could result in compressor failure.

Unit must be powered and crankcase heaters energized at least 8 hours BEFORE compressors are started.

Table 30. Crankcase heater sizes

Compressor Name	Crankcase Heater Watts
YA/YAS	70
CSHD/CSHE	90
CSHN/CSHP	160



Pre-Start

Use the checklist provided below in conjunction with the **General Unit Requirement** checklist” to ensure that the unit is properly installed and ready for operation. Be sure to complete all of the procedures described in this section before starting the unit for the first time.

⚠ WARNING

Hazardous Voltage!

Failure to disconnect power before servicing could result in death or serious injury.

Disconnect all electric power, including remote disconnects before servicing. Follow proper lockout/tagout procedures to ensure the power can not be inadvertently energized. Verify that no power is present with a voltmeter.

- Turn the field supplied disconnect switch, located upstream of the unit, to the **Off** position.
*Note: Verify that the 115 volt control switch (1S1) in the unit control box is in the **Off** position.*
- Check all electrical connections for tightness and **point of termination** accuracy.
- Verify that the condenser airflow will be unobstructed.
- Check the condenser fan blades. Ensure they rotate freely within the fan orifices and are securely fastened to the fan motor shaft.

NOTICE

Compressor Damage!

Excessive liquid accumulation in the suction lines could result in compressor damage.

Do not allow liquid refrigerant to enter the suction line.

- Verify that all compressor service valves, discharge service valves, and liquid line service valves are back seated on each circuit.
Important: Compressor service valves must be fully opened before start-up (suction, discharge, and liquid line).
- Check the compressor oil levels. Oil levels must be near or above the top of all compressor sight glasses.
- Check the condenser coils. They should be clean and the fins should be straight. Straighten any bent coil fins with an appropriate sized fin comb.
- Inspect the interior of the unit for tools and debris.

EVP Chiller Applications

- Flush building piping.

NOTICE

Heat Exchanger Damage!

Failure to follow instructions below could result in heat exchanger damage.

If an acidic commercial flushing solution is used, bypass the EVP chiller to prevent damage .

- Clean strainer. Make sure strainer blow down valve or plug is in place.
- Connect chiller. Make sure chiller 1/2-inchx14 NPTE plug is in place.
- Close drain valve
- Fill system with water.
- Vent system piping at the highest points.
- Inspect water piping for leaks and repair.

System Evacuation Procedures

NOTICE

Operating Under Vacuum!

Failure to follow these instructions will result in compressor failure.

Do not operate or apply power to the compressor while under a vacuum.

Each refrigeration circuit for split system applications must be evacuated before the unit can be started. Use a rotary type vacuum pump capable of pulling a vacuum of 100 microns or less. Verify that the unit disconnect switch and the system control circuit switches are **OFF**.

The oil in the vacuum pump should be changed each time the pump is used with a high quality vacuum pump oil. Before using any oil, check the oil container for discoloration which usually indicates moisture in the oil and/or water droplets. Moisture in the oil adds to what the pump has to remove from the system, making the pump inefficient.

When connecting the vacuum pump to a refrigeration system, it is important to manifold the vacuum pump to both the high and low side of the system (liquid line access valve and suction line access valve). Follow pump manufacturer’s directions for proper methods of using vacuum pump.

The lines used to connect pump to the system should be copper and the largest diameter that can practically be used. Using larger line sizes with minimum flow resistance can significantly reduce evacuation time. Rubber or synthetic hoses are not recommended for system evacuation. They have moisture absorbing characteristics which result in excessive rates of evaporation, causing pressure rise during standing vacuum test. This makes it impossible to determine if system has a leak, excessive

residual moisture, or a continual or high rate of pressure increase due to hoses.

An electronic micron vacuum gauge should be installed in the common line ahead of the vacuum pump shutoff valve, as shown in Figure 70, p. 97. Close Valves B and C, and open Valve A.

Start vacuum pump. After several minutes, the gauge reading will indicate the maximum vacuum the pump is capable of pulling. Rotary pumps should produce vacuums of 100 microns or less.

Open Valves B and C. Evacuate the system to a pressure of 300 microns or less. As vacuum is being pulled on the system, it may appear that no further vacuum is being obtained, yet the pressure is high. To facilitate the evacuation process, it is recommended that the vacuum be **Broken**.

To break the vacuum, close valves A, B, and C and connect a refrigerant cylinder to the charging port on the manifold. Purge the air from the hose. Raise the standing vacuum pressure in the system to **zero** (0 psig) gauge pressure. Repeat this process two or three times during evacuation.

Note: It is unlawful to release refrigerant into the atmosphere. When service procedures require working with refrigerants, the service technician must comply with all Federal, State, and local laws.

Standing Vacuum Test

Once 300 microns or less is obtained, close Valve A and leave valves B and C open. This will allow the vacuum gauge to read the actual system pressure. Let the system equalize for approximately 15 minutes. This is referred to as a **standing vacuum test** where, time versus pressure rise. The maximum allowable rise over a 15 minute period

is 200 microns. If the pressure rise is greater than 200 microns but levels off to a constant value, excessive moisture is present. If the pressure steadily continues to rise, a leak is indicated. Figure 71, p. 97 illustrates three possible results of the **standing vacuum test**.

If a leak is encounter, repair the system and repeat the evacuation process until the recommended vacuum is obtained. Once the system has been evacuated, break the vacuum with refrigerant, and complete the remaining **Pre-Start Procedures** before starting the unit.

Figure 70. Typical vacuum pump hookup

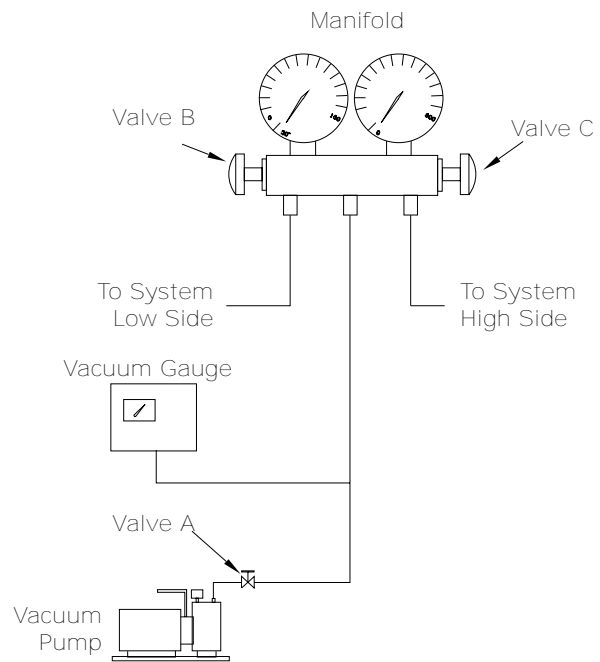
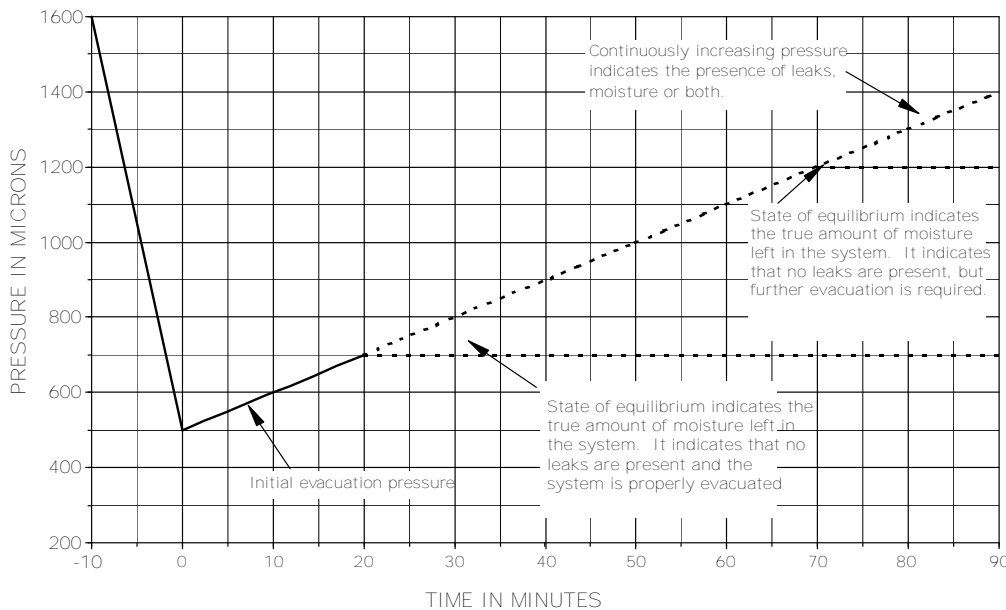

Figure 71. Evacuation time vs. pressure rise



Voltage Imbalance

Excessive three phase voltage imbalance between phases will cause motors to overheat and eventually fail. The maximum allowable voltage imbalance is two percent. Measure and record the voltage between phases 1, 2, and 3 and calculate the amount of imbalance as follows:

% Voltage Imbalance = $100 \times [(AV - VD)/(AV)]$ where:

- AV (Average Voltage) = $(\text{Volt 1} + \text{Volt 2} + \text{Volt 3})/3$
- V1, V2, V3 = Line Voltage Readings
- VD = Line Voltage reading that deviates the farthest from the average voltage.

Example:

If voltage readings of supply power measured 221, 230, and 227, average volts would be:

- $AV = (221 + 230 + 227)/3 = 226 \text{ Avg.}$
- $VD = 221$

The percentage of imbalance is calculated as follows:

- $100 \times [(226 - 221)/226] = 2.2\%$

The 2.2% imbalance in this example exceeds the maximum allowable imbalance of two percent. This much imbalance between phases can equal as much as a 20% current imbalance with a resulting increase in motor winding temperatures that will decrease motor life. If the voltage imbalance is over two percent, notify the proper agencies to correct the voltage problem before operating this equipment.

as Associated Research Model 45 Phase Sequence Indicator, following steps below

- Turn field supplied disconnect switch that provides power to the condensing unit to Off position
- Verify that the 115 volt control switch (1S1) in the unit control box is in the Off position.
- Connect the phase sequence indicator leads to the terminal block or to the Line side of the optional factory mounted disconnect switch as follows:
 - Black (phase A) to L1
 - Red (phase B) to L2
 - Yellow (phase C) to L3
- Close the main power disconnect switch or circuit protector switch that provides the supply power to the condensing unit.
- Observe the ABC and CBA phase indicator lights on the face of the sequencer. The ABC indicator light will glow if the phase is ABC. If the CBA indicator light glows, open the disconnect switch or circuit protection switch and reverse any two power wires.
- Restore the main electrical power and recheck the phasing.
- If the phasing is correct, open the main power disconnect switch or circuit protection switch and remove the phase sequence indicator.

Electrical Phasing

WARNING

Hazardous Voltage!

Failure to disconnect power before servicing could result in death or serious injury.

Disconnect all electric power, including remote disconnects before servicing. Follow proper lockout/tagout procedures to ensure the power can not be inadvertently energized. Verify that no power is present with a voltmeter.

WARNING

Live Electrical Components!

Failure to follow all electrical safety precautions when exposed to live electrical components could result in death or serious injury.

When it is necessary to work with live electrical components, have a qualified licensed electrician or other individual who has been properly trained in handling live electrical components perform these tasks.

Proper electrical phasing can be quickly determined and corrected before starting unit by using an instrument such



Start-Up

Low Ambient Damper Adjustment (Factory or Field Installed)

When a unit is ordered with the low ambient option (model number digit 11 =1), a damper is factory installed over the lead condenser fan for each refrigeration circuit. See Component Location drawings in the chapter for damper location illustrations for the appropriate unit.

For field installation, see Low Ambient Kit Commercial Air Conditioners Installation Guide (ACC-SVN316*-EN).

⚠ WARNING

Live Electrical Components!
 Failure to follow all electrical safety precautions when exposed to live electrical components could result in death or serious injury.
 When it is necessary to work with live electrical components, have a qualified licensed electrician or other individual who has been properly trained in handling live electrical components perform these tasks.

Inspect the damper blades for proper alignment and operation. Dampers should be in the closed position during the "Off" cycle.

NOTICE

Actuator Damage!
 Do not depress actuator clutch while actuator is energized as it could result in actuator damage.

To check damper operation, navigate to Manual Control Settings via the user interface. From the Manual Control Settings, navigate to Low Ambient Damper Manual OvrD CktX. Change the value to a percent opening 0 - 100% position.

EVP Chiller Applications

Start the chilled water circulating pump by closing the field provided pump disconnect switch and turn the pump control circuit switch **On**.

Check the flow device to ensure it opens at minimum flow and closes properly.

With water circulating through the system, check the EVP chiller pressure drop and adjust the flow (if necessary). Refer to the appropriate EVP chiller size in for the operating pressure drop.

Freezestat Setting

At the remote panel, set the freezestat at a minimum of 5°F above the chilled water freezing temperature.

System Airflow Verification

Much of the systems performance and reliability is closely associated with, and dependent upon having the proper airflow supplied both to the space that is being conditioned and across the evaporator coil. Verify the supply fan is providing adequate air flow per air handler specifications.

Preliminary Expansion Valve Adjustment

NOTICE

Compressor Damage!
 Failure to follow instructions could result in compressor failure or reduced compressor life.
 Increase thermal expansion valve superheat settings before starting compressors to minimize compressor operation with low oil viscosity.

No bleed thermal expansion valves are set by manufacturers to control between 12°F to 14.4°F superheat leaving the evaporator at nominal design conditions. Thermal expansion valves with bleeds are set to their highest superheat setting. Actual superheat depends on many factors (valve vs. system relative sizing, operating conditions, system load step, system charge, piping, and condenser fan control). The thermal expansion valves must be adjusted as part of the unit start-up procedure. Do not adjust valves beyond manufacturer's available nominal adjustment range.

Table 31. R-410A thermal expansion valve manufacturer settings (no bleed) – Emerson

Valve	Nom Tons	Superheat °F	CW Turns Available	CCW Turns Available	Superheat_change_per_turn	Field_adjust_for_18°F_DX	Field_adjust_for_15°F_EVP
C	1-1/2 to 7	13	6	6	4	1.25 CW	—
TF	12 to 20		5	5	2	2.5 CW	1.0 CW



Start-Up

Table 32. R-410A thermal expansion valve manufacturer settings (no bleed) – Danfoss

Valve	Body size	SHT °F	CW turns available	CCW turns available	Superheat change per turn	Field adjust for 18°F (DX evap coil)	Field adjust for 15°F (EVP only)
TGEL 3.5 TR / TGE 10	14.4	4	3	4.5	0.75	—	—
TGEL 4.5 TR	—	—	—	—	—	—	—
TGEL 6.5 TR	—	—	—	—	—	—	—
TGEL 9 TR	—	—	—	—	—	—	—
TGEL 13 TR	—	—	—	—	—	—	—
TGEL 15 TR / TGE 20	7.0	3	3	1.25	CW	CW	—
TGEL 19 TR	—	—	—	—	—	—	—
TGEL 23 TR	—	—	—	—	—	—	—
TGEL 31 TR	—	—	—	—	—	—	—
TGEL 35 TR / TGE 40	4.0	—	—	—	—	—	—
TGEL 46 TR	—	—	—	—	—	—	—

Table 33. R-454B thermal expansion valve manufacturer settings (no bleed) – Sporlan

Standard Off the Shelf Nominal Valve Settings (85 PSIG Air Test Setting)						
Valve	Superheat °F	CW Turns Available	CCW Turns Available	Superheat Change Per Turn	Field Adjust for 18°F (DX Evap Coil)	Field Adjust for 15°F (EVP Only)
BBIYE 1.5-CP	12	4.5	4.5	2.4°F	2.5 CW	—
BBIYE 2.5-CP						
BBIYE 3-CP						
BBIYE 4.5-CP						
BBIYE 6-CP						
BBIYE 7-CP						
BBIYE 8.5-CP						
BBIYE 11.5-CP						
BBIYE 15.5-CP						
BBIYE 18-CP						
OYE-20-CP						
OYE-25-CP						
OYE-35-CP						
OYE-55-CP						
				1.8°F	3.25 CW	1.75 CW

Information in the table above is approximate and intended to simplify field adjustment by presetting valves to approximately 18°F superheat for DX evap coils and 15°F superheat for EVP chillers. Actual operating superheat will typically be less than 18°/15°F and varies depending on many factors including those listed above. Superheat gradient (superheat change per turn) is also approximate and will not be constant throughout the valve adjustment range. Check superheat after startup to confirm proper control.

Tag or mark valve to keep a record of any field adjustments.

Adding Preliminary Charge

1. Leak check must be completed and system evacuated.
2. Verify that oil levels are near or above the top of all compressor sight glasses.

⚠ WARNING

Hazardous Voltage!

Failure to disconnect power before servicing could result in death or serious injury.

Disconnect all electric power, including remote disconnects before servicing. Follow proper lockout/tagout procedures to ensure the power can not be inadvertently energized. Verify that no power is present with a voltmeter.

3. Confirm field supplied unit disconnect is **OFF**. Additionally, turn all compressor circuit breakers to the OFF position. Refer to unit wiring diagrams for compressor circuit breaker locations.
4. Turn field supplied unit disconnect **ON** to energize crankcase heaters. Verify crankcase heaters are operating.
5. Verify that discharge, suction, and liquid line service valves are open.
6. If system is equipped with hot gas bypass, insure hot gas bypass is closed and remains closed during charging.
7. Refer to table below for the charge estimate for the condensing unit circuit and piping at the appropriate piping length.

Table 34. Recommended maximum charge per circuit (lbs)—condensing unit and lines only (does not include evaporator) – R-410A

Valve	Total Interconnecting Line Length (ft)		
	50	100	150
20	19	25	32
25	25	37	50
30	25	38	50
40	25	37	50
50	25	38	50
60	24	36	48
80	49	69	88
100	52	73	94
120	55	76	98

Table 35. Recommended maximum charge per circuit (lbs)—condensing unit and lines only (does not include evaporator) – R-454B

Unit Size	Total Interconnecting Line Length (ft)		
	50	100	150
20	18	28	39
25	18	30	41
30	20	31	42

Table 35. Recommended maximum charge per circuit (lbs)—condensing unit and lines only (does not include evaporator) – R-454B (continued)

Unit Size	Total Interconnecting Line Length (ft)		
	50	100	150
40	18	29	39
50	19	30	42
60	19	31	42
80	38	56	74
100	39	58	78
120	41	60	79

NOTICE

Compressor Damage!

Excessive liquid accumulation in the suction lines could result in compressor damage.

Do not allow liquid refrigerant to enter the suction line.

8. At the liquid line angle valve add as much R-410A/R-454B LIQUID as possible up to, but not exceeding, that listed in . It may not be possible to add more than 60% of the charge due to system conditions. This will be adequate for compressor startup. More charge will be added after compressors are started. Use an accurate scale to measure and record the preliminary amount of R-410A/R-454B added to each circuit.
9. Do not add refrigerant in the suction line at this time to prevent excessive refrigerant in the low side prior to compressor start-up.

Compressor Start-Up (All Systems)

Table 36. Minimum starting ambient temperature – R-410A

Unit size	Minimum Starting Ambient ^(a) (°F)			
	Standard Units		Low Ambient Units	
	With HGBP	No HGBP	With HGBP	No HGBP
20-60	45	40	10	0
80-120	45	40	10	0

^(a) Minimum starting ambients in degrees F and is based on the unit operating at minimum step of unloading and 5 mph wind across condenser.



Start-Up

Table 37. Minimum starting ambient temperature – R-454B

Minimum Starting Ambient ^(a) (°F)			
Standard Units		Low Ambient Units	
With HGBP	No HGBP	With HGBP	No HGBP
50	50	10	0

^(a) Minimum starting ambients in degrees F and is based on the unit operating at minimum step of unloading and 5 mph wind across condenser.

- Review “Adding Preliminary Charge,” p. 100 and confirm all steps were completed.

NOTICE

Compressor Damage!

Failure to follow instructions could result in compressor damage.

Keep crankcase heaters on whenever refrigerant is in the system.

If crankcase heaters have not been on with refrigerant in the system, turn the crankcase heaters on for a minimum of 8 hours before starting compressors.

Notes:

- Initial compressor start-up is best done above 70°F outdoor temperature with ample evaporator load (at least 70°F return air and 350 CFM/Ton).
- Table 37, p. 102 gives the minimum starting temperatures for both “Standard” and “Low” Ambient units.

Important: Do not attempt to charge the system with the low ambient dampers and/or hot gas bypass operating (if applicable). Disable low ambient dampers in the “Open” position (refer to the “Low Ambient Damper Adjustment (Factory or Field Installed),” p. 99) and verify hot gas bypass is not operating before proceeding.

- On units with dual circuits, work on only one circuit at a time. See tables in “Compressor Sequencing,” p. 106 for the compressor sequencing and Operating Principals chapter Component Location illustrations for their location.
- Compare the amount of preliminary charge added in the preceding section to the table in that section for condensing unit and piping only. Up to 20% more charge than listed in that table may be required to fully charge the circuit, depending on the evaporator design. Have adequate R-410A/R-454B available to complete charging as described in the following steps.
- Attach a thermocouple type temperature sensor on the liquid line close to the liquid line service valve. To insure an accurate liquid temperature reading, clean the line where the sensor is attached. After securing the sensor

to the line, insulate the sensor and line to isolate it from the ambient air.

- Attach a set of service gauges onto the suction and discharge gauge ports.
- Check the low side pressure. If the low side pressure is less than 78 psig, refrigerant may need to be added to the suction line before starting the compressor(s). Slowly meter into the suction line only as much R-410A/R-454B as needed. If possible, plan to use this entire refrigerant bottle on the same unit in order to minimize fractionalization. Use an accurate scale to measure and record the amount of R-410A/R-454B added.

WARNING

Hazardous Voltage!

Failure to disconnect power before servicing could result in death or serious injury.

Disconnect all electric power, including remote disconnects before servicing. Follow proper lockout/tagout procedures to ensure the power can not be inadvertently energized. Verify that no power is present with a voltmeter.

- Switch the field supplied unit disconnect **OFF**. Open the unit control box and turn the compressor circuit breakers to the OFF position for the circuit that is not being started. Refer to unit wiring diagrams for compressor circuit breaker locations.
- Switch the 115 volt (1S1) control circuit switch **ON**. Close the control box and then switch the field supplied unit disconnect **ON**. Unit power should be off no longer than 30 minutes to prevent refrigerant migration to compressor sumps. If power is off for longer than 30 minutes, allow time for crankcase heaters to drive refrigerant from compressor sumps before starting compressors.

NOTICE

Compressor Damage!

Failure to follow instructions could result in compressor damage.

Keep crankcase heaters on whenever refrigerant is in the system.

If crankcase heaters have not been on with refrigerant in the system, turn the crankcase heaters on for a minimum of 8 hours before starting compressors.

- Verify that oil levels are near or above the top of all compressor sight glasses.

⚠ WARNING

Live Electrical Components!

Failure to follow all electrical safety precautions when exposed to live electrical components could result in death or serious injury.

When it is necessary to work with live electrical components, have a qualified licensed electrician or other individual who has been properly trained in handling live electrical components perform these tasks.

NOTICE

Compressor Damage!

Failure to follow instructions below could result in compressor damage.

Improper power phasing will cause compressor to run backwards. Compressor could be running backwards if it is noisy, low side shell gets hot, suction pressure does not drop within 5 seconds after startup, and compressor only draws ½ expected amps. Stop the compressor immediately and have a qualified electrician or technician properly trained in 3 phase power correct the wiring.

10. Start the first compressor only. Refer to unit schematics and programming guide (SS-SVP018*-EN) if necessary.
 - a. If the compressor and condenser fans do not start, the field power wiring to the RAUK unit could be improperly phased. A main unit power phase protection module (1K1) is located in the RAUK control box and interrupts control circuit power when improperly phased field power is detected.
 - Compressors used on 20 to 60 ton units are not equipped with electronic modules and do not have individual compressor phase protection.
 - Compressors used on 80 to 120 ton units are individually equipped with compressor protection modules located in the compressor junction boxes. These modules include phase, voltage, overcurrent, and over temperature protection. If CSHP compressors are started with reversed phasing, the module output relay will open in about 6 seconds.

Note: Refer to the Service and Maintenance section of this manual or Service Guide - Compressor Replacement Recommendations (PART-SVG002*-EN) for further discussion regarding other potential compressor protection module faults.
 - b. As soon as a compressor starts, verify correct rotation. If a scroll compressor is allowed to run backwards for even a very short period of time, internal compressor damage could occur and compressor life could be reduced. When rotating backwards scroll compressors make a loud noise, do not pump, draw about 1/2 expected amps, and the low side shell gets hot. Immediately shut off a compressor rotating backwards.
 - c. Check condenser fans for proper rotation. As viewed from the top of the unit, the correct rotation direction is clockwise. See “Electrical Phasing,” p. 98.
 - d. Start the remaining circuit compressor(s). Verify correct rotation. Incorrect rotation is noisy, compressor draws about ½ expected amps, and the low side shell gets hot. Immediately shut off any compressors rotating backwards.
 - e. After allowing 10 minutes for circuit operation to stabilize at full load, check the liquid temperature and discharge pressure. Plot on Figure 73, p. 105. Expect the operating point to be in the "Add charge" portion of the chart. The remainder of the circuit charge will be added in the following steps.
 - f. Subtract the total charge already added from the table in Preliminary Charging section charge estimate for condensing unit at the appropriate piping length. Add no more R-410A/R-454B than 1/2 of this difference at a time.
 - g. With all the circuit compressors operating, SLOWLY meter R-410A/R-454B into the suction line from the LIQUID charging connection. Add no more than 1/2 of the difference from Step 10f above. Then allow the unit to run for 10 minutes, and plot the new operating point on Figure 73, p. 105. Use an accurate scale to measure and record the amount of R-410A/R454-B added.
 - h. Repeat Step 10g, adding smaller increments of refrigerant until circuit operation is approximately on the appropriate line of Figure 73, p. 105. As the charging line is approached, smaller increments of refrigerant will move the operating point more.

Note: This procedure results in less subcooling than previous split system charging methods. Note that using this charging method will at times result in bubbles at sight glasses installed just upstream of expansion valves; especially during lower ambient operation, part load, and for systems with evaporators located above condensing units. This charging procedure will maximize the usable operating envelope of the R-410A/R-454B RAUK units.

Important: Do not release refrigerant to the atmosphere! If adding or removing refrigerant is required, the service technician must comply with all Federal, State, and local laws. Refer to general service bulletin MSCU-SB-1 (latest edition).
 - i. Record the total charge added to the circuit.

Start-Up

- j. If applicable, repeat [Step 10a](#) through [Step 10i](#) on the second refrigeration circuit. Turn the correct compressor circuit breakers on/off as needed. Refer to unit wiring diagrams for compressor circuit breaker locations.
11. After the unit has been operating for approximately 30 minutes at full load with all condenser fans running, record the operating pressures. Operating pressures should be within +/- 10 Psig of the appropriate pressure curve in [Figure 73, p. 105](#). Measure and record the system subcooling and superheat as described in the following sections.
 12. Verify that the oil level in each compressor is correct. As a minimum, oil must be visible in the sight glass.
 13. Once the checks and adjustments for the operating circuit has been completed, check and record the following data on the maintenance log shown at the end of the chapter. Repeat these procedures for the second refrigeration circuit, if applicable.
 - ambient temperature;
 - compressor oil level (each circuit);
 - compressor suction and discharge pressures and liquid line temperatures (each circuit);
 - superheat and subcooling (each circuit);
 14. Turn the 115-volt control circuit switch 1S1 to the “OFF” position and open the field provided or optional factory mounted disconnect switch.
 15. After shutting the system off, check the compressor oil appearance. Discoloration of the oil indicates that an abnormal condition has occurred.
 - a. If the oil is dark and smells burnt, it has overheated because of: compressor operating at extremely high condensing temperatures; high superheat; a compressor mechanical failure; or, occurrence of a motor burnout.
 - b. If the oil is black and contains metal flakes, a mechanical failure has occurred. This symptom is often accompanied by a high compressor amperage draw.
 - c. If a motor burnout is suspected, use an acid test kit to check the condition of the oil. Test results will indicate an acid level exceeding 0.05 mg KOH/g if a burnout occurred.

Figure 72. System charging chart (all units) R-410A

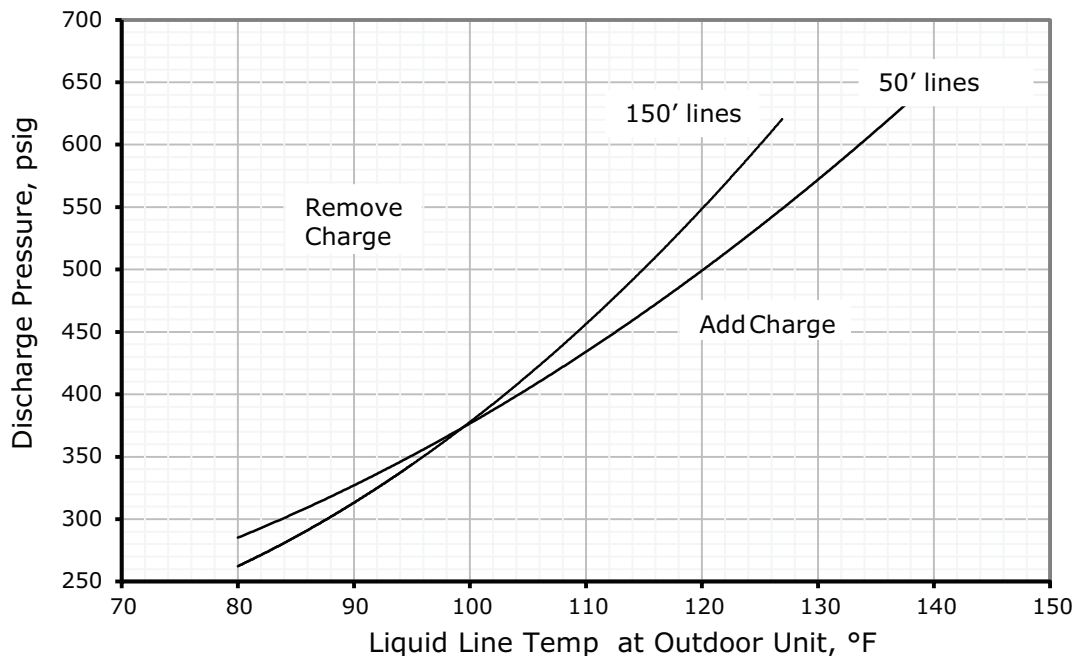
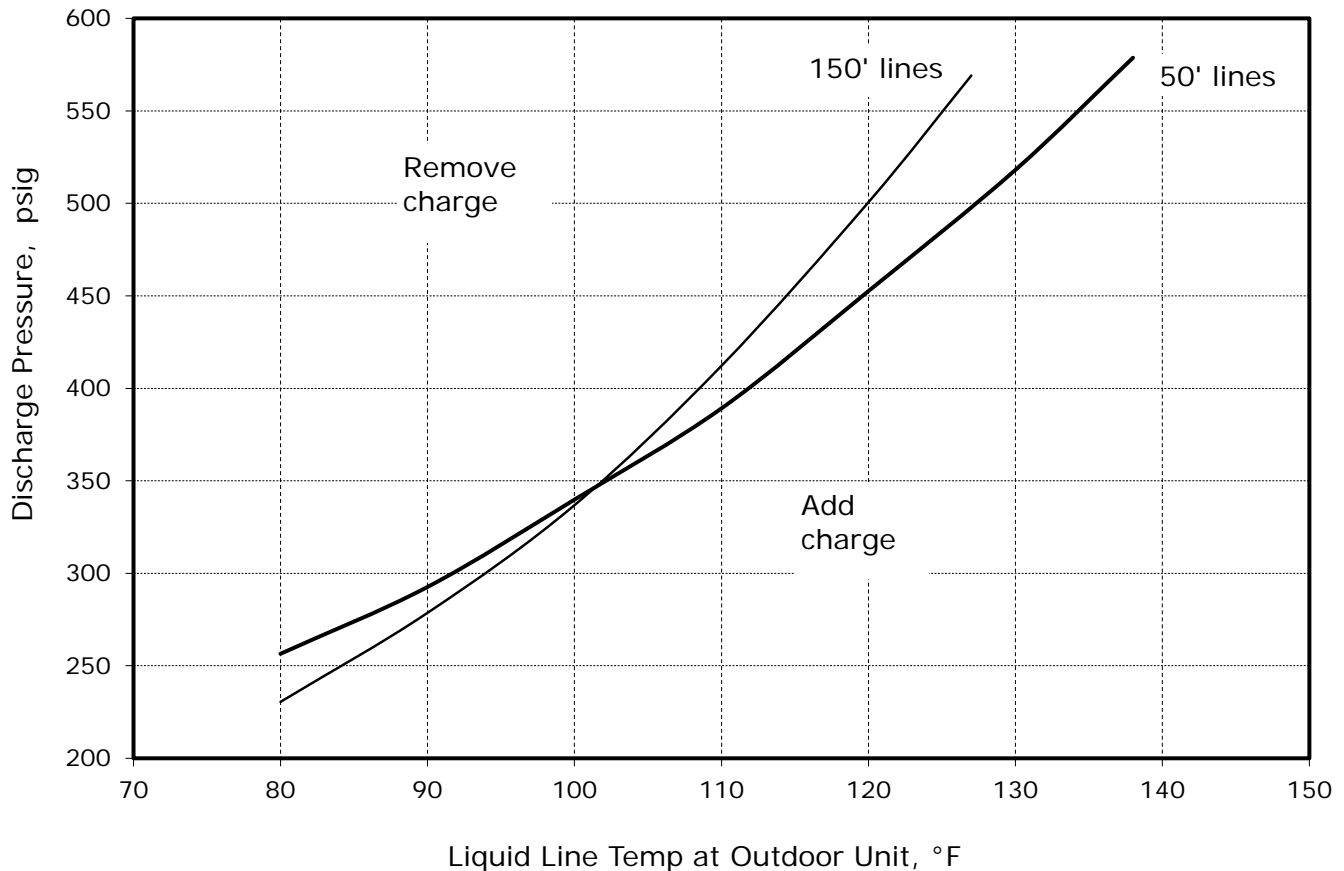

Figure 73. System charging chart (all units) R-454B



Subcooling

The outdoor ambient temperature must be between 65°F and 105°F and the relative humidity of the air entering the evaporator must be above 40 percent. When the temperatures are outside of these ranges, measuring the operating pressures can be meaningless.

With the unit operating at “Full Circuit Capacity”, acceptable subcooling ranges between 8°F to 16°F.

Measuring Subcooling

Note: System charging is done by using the System Charging Chart. Do not attempt to charge the system based on subcooling.

- At the liquid line service valve, measure the liquid line pressure. Using a Refrigerant R-410A/R-454B pressure/temperature chart, convert the pressure reading into the corresponding saturated temperature.
- Measure the actual liquid line temperature as close to the liquid line service valve as possible. To ensure an accurate reading, clean the line thoroughly where the temperature sensor will be attached. After securing the sensor to the line, insulate the sensor and line to isolate it from the ambient air.

Note: Glass thermometers do not have sufficient contact area to give an accurate reading.

- Determine the system subcooling by subtracting the actual liquid line temperature from the saturated liquid temperature.

Measuring Superheat

- Measure the suction pressure at the outlet of the evaporator as close to the expansion valve bulb location as possible.
- Measure the suction line temperature as close to the expansion valve bulb, as possible.
- Using a Refrigerant/Temperature chart, convert the pressure reading to a corresponding saturated vapor temperature.

Note: On many Trane fan/coil units, an access valve is provided close to the expansion valve bulb location. This valve must be added on climate changers and other evaporators.

- Subtract the saturated vapor temperature, from the actual suction line temperature. The difference between the two temperatures is known as superheat.



Start-Up

Compressor Oil

NOTICE

Compressor Damage!

POE oil is hygroscopic – it absorbs water directly from the air. This water is nearly impossible to remove from the compressor oil and can result in compressor failures.

To prevent POE oil from absorbing water, the system should not remain open for longer than necessary. When open, dry nitrogen should flow through the piping. Only new oil containers should be used for service and maintenance. Always use the smallest container size required for the job requirements. Always leave the oil container tightly sealed until time of use. Do not reuse oil that has been opened.

For RAUK units only, replacement compressors ship fully charged with POE oil. The scroll compressor uses POE oil (OIL00079 for a quart container or OIL00080 for a gallon container) without substitution. The appropriate oil charge for a 7.5 ton scroll compressor is 6.3 pints. For 9 through 15 ton light commercial scroll compressors is 7 pints. For a 15 and 20 ton large commercial scroll compressors (80 to 120 ton units), use 14.2 pints.

Compressor Crankcase Heaters

Table 38. Heater information

Compressor Configuration and Size	Heater (watt)	Quantity (per compressor)
CSHD 7.5 to 15 tons	90	1
CSHN 15 to 20 tons	160	1

Table 39. Pressure control switch settings (psi)

Pressure Switch	Make	Break
Hi Pressure	550	650
Lo Pressure	78	58
Condenser Fan Cycling switch	444	255
EVP Lo Pressure	105	82

Compressor Sequencing

Table 40. R-454B compressor sequence: 20 to 120 tons

Unit Size	Control Staging	Circuit 1	Circuit 2	% Loaded Unit
20	1	1B Unloaded	-	23
	2	1B		40
	3	1A, 1B Unloaded		82
	4	1A, 1B	-	100
25	1	1B Unloaded	-	22
	2	1B		40
	3	1A		60
	4	1A, 1B Unloaded		82
	5	1A, 1B	-	100
30	1	1A	-	25
	2	1B		38
	3	1A, 1B		62
	4	1B, 1C		75
	5	1A, 1B, 1C	-	100
40	1	1A	-	23
	2	1A	2A	46
	3	1A, 1B	2A	73
	4	1A, 1B	2A, 2B	100
50	1	1A	-	24
	2	1A	2A	48
	3	1A, 1B	2A	74
	4	1A, 1B	2A, 2B	100
60	1	1A	-	25
	2	1A	2A	50
	3	1A, 1B	2A	75
	4	1A, 1B	2A, 2B	100
80	1	1A	-	17
	2	1A	2A	33
	3	1A, 1B	2A	50
	4	1A, 1B	2A, 2B	66
	5	1A, 1B, 1C	2A, 2B	83
	6	1A, 1B, 1C	2A, 2B, 2C	100

Table 40. R-454B compressor sequence: 20 to 120 tons (continued)

Unit Size	Control Staging	Circuit 1	Circuit 2	% Loaded Unit
100	1	1A	-	15
	2	1A	2A	30
	3	1A, 1B	2A	45
	4	1A, 1B	2A, 2B	59
	5	1A, 1B, 1C	2A, 2B	80
	6	1A, 1B, 1C	2A, 2B, 2C	100
120	1	1A	-	17
	2	1A	2A	33
	3	1A, 1B	2A	50
	4	1A, 1B	2A, 2B	66
	5	1A, 1B, 1C	2A, 2B	83
	6	1A, 1B, 1C	2A, 2B, 2C	100

Note: Compressor sequencing applies to Supply Air VAV and EVP control only. No Control units are staged based on compressor request by the user.

Table 41. R-410A compressor sequence: 20 to 120 tons

Unit Size	Step	Circuit 1	Circuit 2	% Loaded
20	1	1A	—	50
	2	1A, 1B	—	100
25	1	1A	—	42
	2	1A, 1B	—	100
30	1	1A	—	50
	2	1A, 1B	—	100
40	1	1A	-	25
	2	1A	2A	50
	3	1A, 1B	2A	75
	4	1A, 1B	2A, 2B	100
50	1	1A	—	23
	2	1A	2A	46
	3	1A, 1B	2A	73
	4	1A, 1B	2A, 2B	100
60	1	1A	—	25
	2	1A	2A	50
	3	1A, 1B	2A	75
	4	1A, 1B	2A, 2B	100

Table 41. R-410A compressor sequence: 20 to 120 tons (continued)

Unit Size	Step	Circuit 1	Circuit 2	% Loaded
80	1	1A	—	17
	2	1A	2A	33
	3	1A, 1B	2A	50
	4	1A, 1B	2A, 2B	66
	5	1A, 1B, 1C	2A, 2B	83
	6	1A, 1B, 1C	2A, 2B, 2C	100
100	1	1A	—	15
	2	1A	2A	30
	3	1A, 1B	2A	45
	4	1A, 1B	2A, 2B	60
	5	1A, 1B, 1C	2A, 2B	80
	6	1A, 1B, 1C	2A, 2B, 2C	100
120	1	1A	—	17
	2	1A	2A	33
	3	1A, 1B	2A	50
	4	1A, 1B	2A, 2B	66
	5	1A, 1B, 1C	2A, 2B	83
	6	1A, 1B, 1C	2A, 2B, 2C	100

Pressure Curves

Note: For the following curves, all compressors and condenser fans are running.

To check operating pressures:

1. Start the unit and allow the pressures to stabilize.
2. Measure the outdoor air dry bulb temperature (°F) entering the condenser coil.
3. Measure the discharge and suction pressure (psig) next to the compressor.
4. Plot the outdoor dry bulb temperature and the operating suction pressure (psig) onto the chart.
5. At the point of intersection, read to the left for discharge pressure. Measured discharge pressure should be within +/- 10 psig of graph.



Start-Up

Figure 74. R-410A 20 ton cooling cycle pressure curve

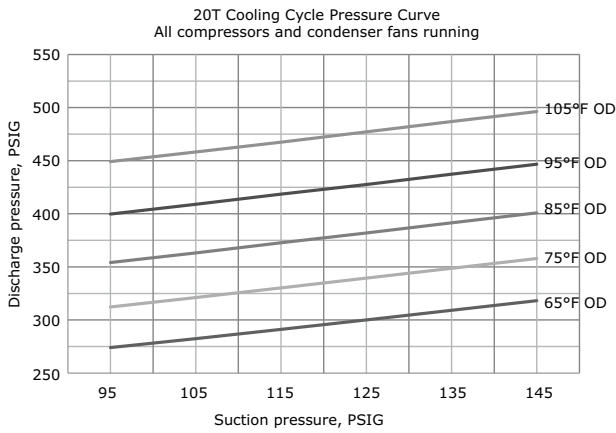

Figure 77. R-454B 25 ton cooling cycle pressure curve

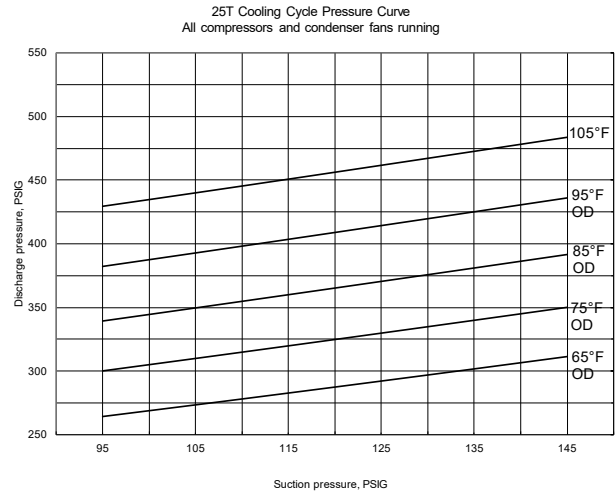

Figure 75. R-454B 20 ton cooling cycle pressure curve

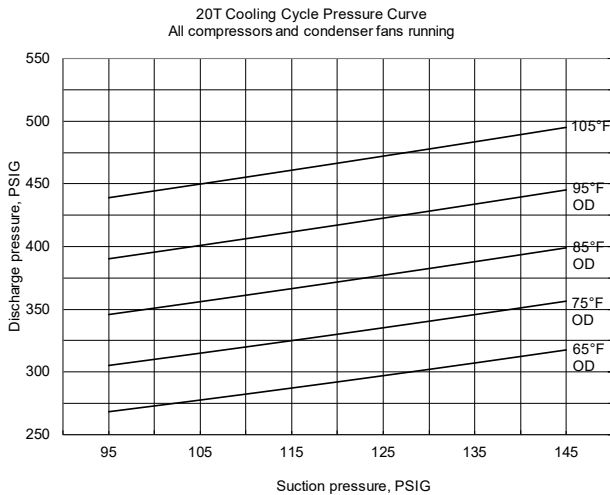

Figure 78. R-410A 30 ton cooling cycle pressure curve

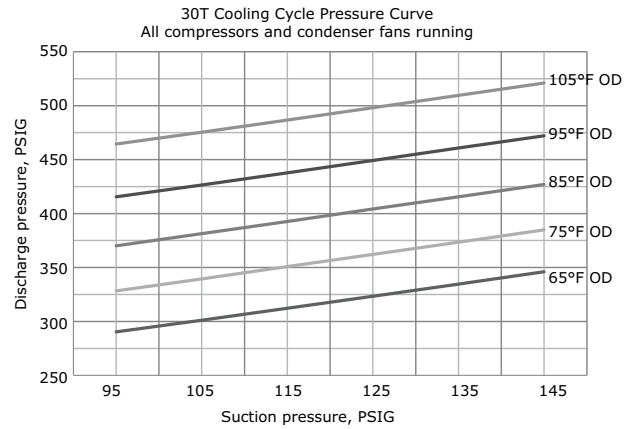

Figure 76. R-410A 25 ton cooling cycle pressure curve

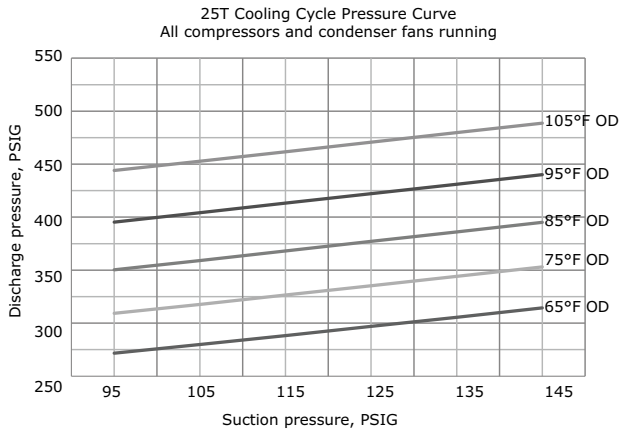

Figure 79. R-454B 30 ton cooling cycle pressure curve

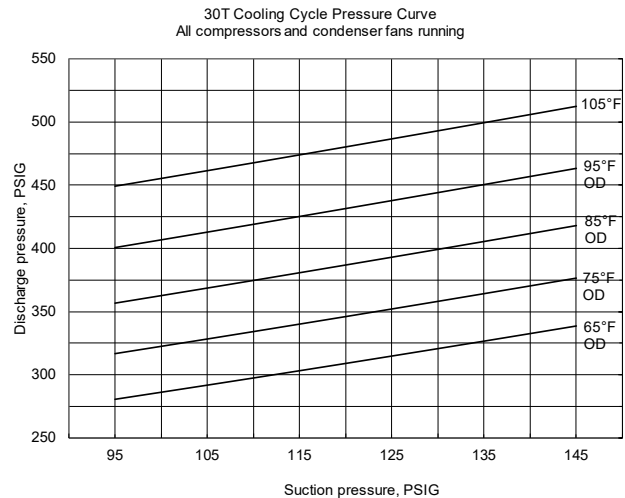

Figure 80. R-410A 40 ton cooling cycle pressure curve

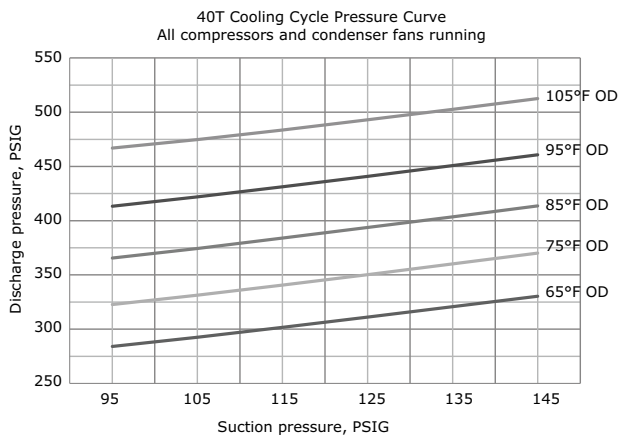

Figure 83. R-454B 50 ton cooling cycle pressure curve

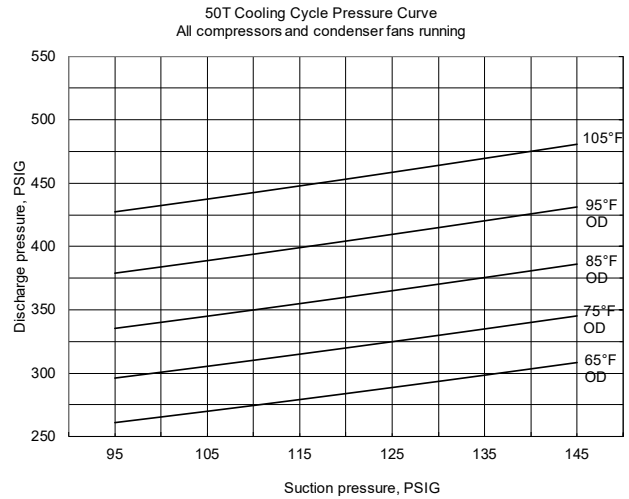

Figure 81. R-454B 40 ton cooling cycle pressure curve

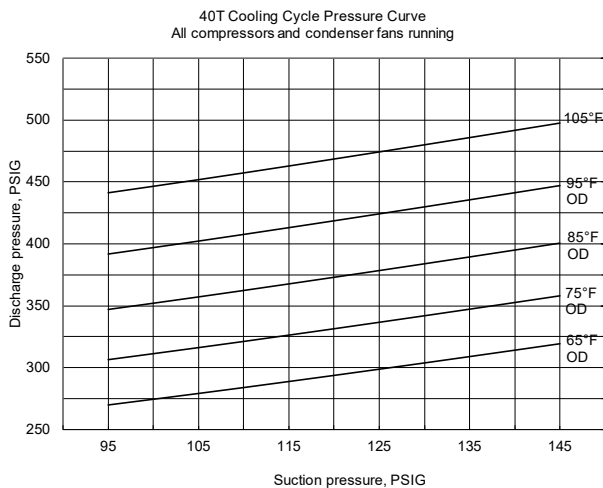

Figure 84. R-410A 60 ton cooling cycle pressure curve

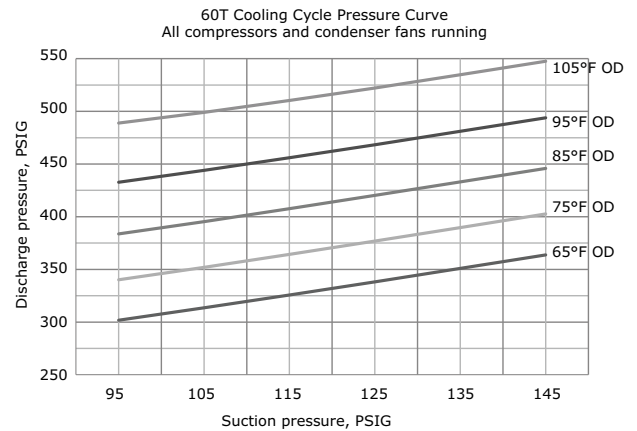
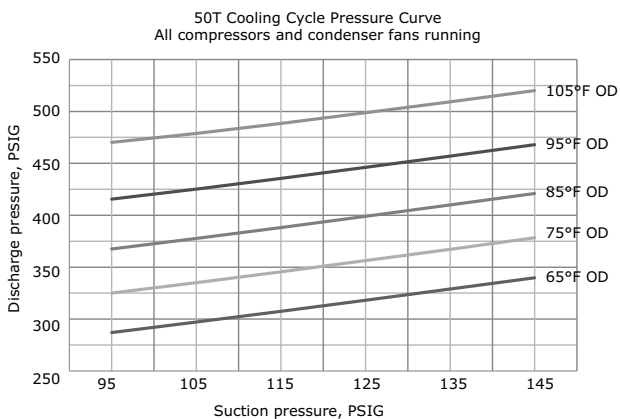

Figure 82. R-410A 50 ton cooling cycle pressure curve





Start-Up

Figure 85. R-454B 60 ton cooling cycle pressure curve

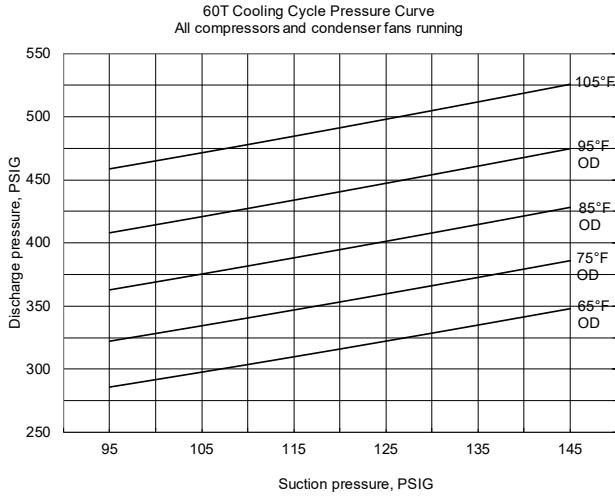

Figure 87. R-454B 80 ton cooling cycle pressure curve

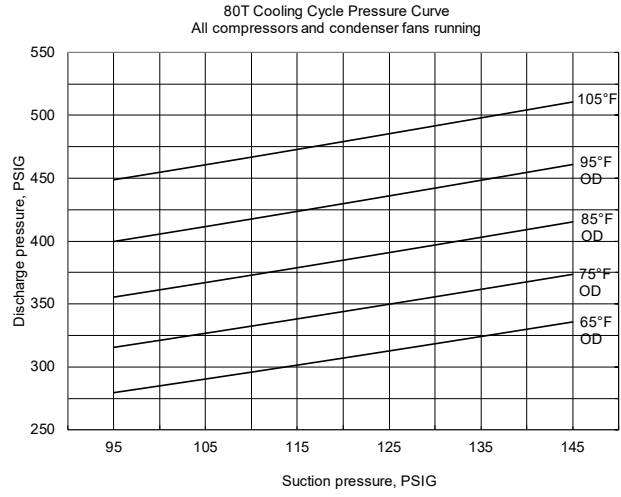

Figure 86. R-410A 80 ton cooling cycle pressure curve

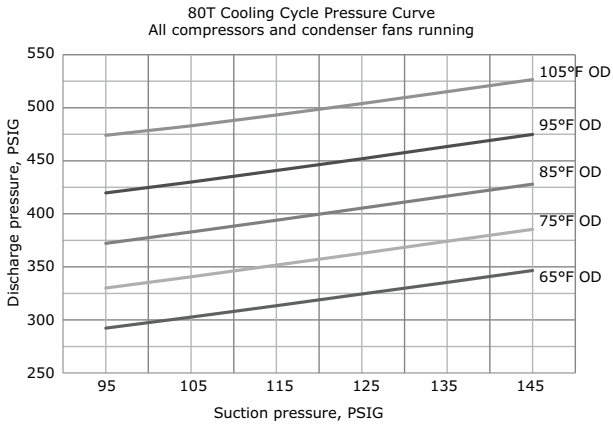

Figure 88. R-410A 100 ton cooling cycle pressure curve

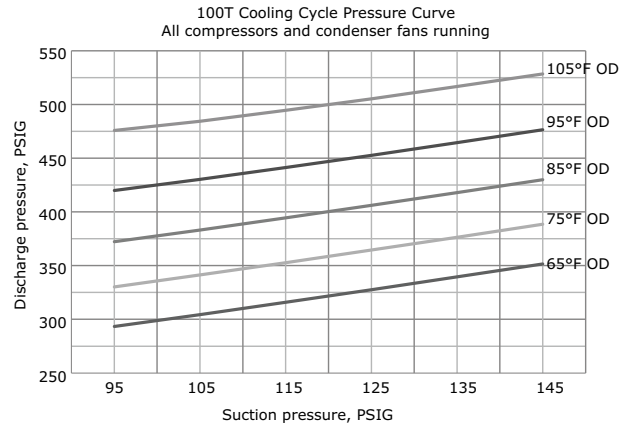

Figure 89. R-454B 100 ton cooling cycle pressure curve

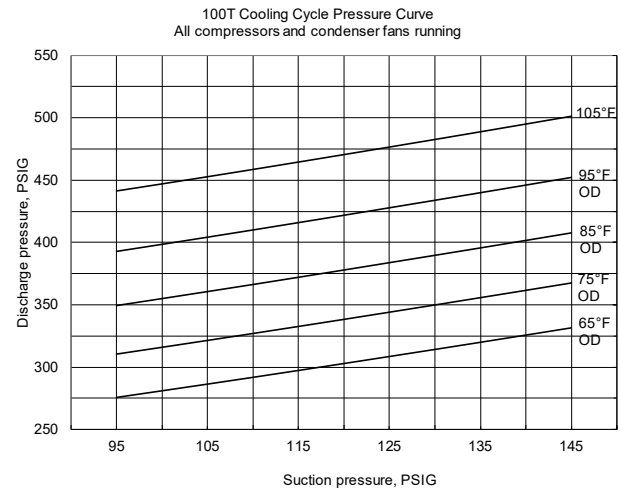

Figure 90. R-410A 120 ton cooling cycle pressure curve

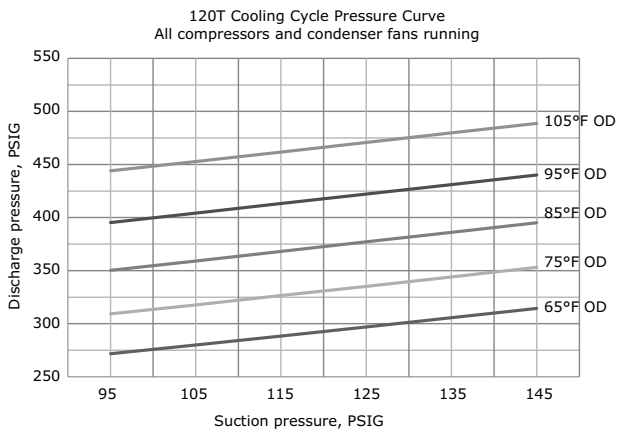
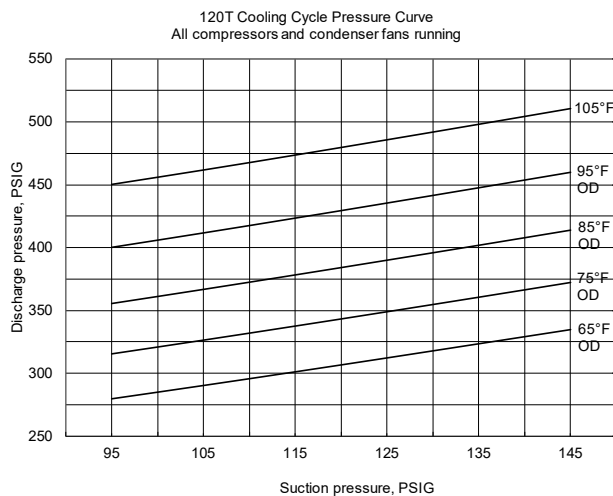

Figure 91. R-454B 120 ton cooling cycle pressure curve



Final System Setup

⚠ WARNING

Hazardous Voltage!

Failure to disconnect power before servicing could result in death or serious injury.

Disconnect all electric power, including remote disconnects before servicing. Follow proper lockout/tagout procedures to ensure the power can not be inadvertently energized. Verify that no power is present with a voltmeter.

After completing the Pre-start and Start-up procedures outlined in the previous sections, perform these final checks before leaving the unit:

- Set the correct "Operating Temperature" for the system at the system controller. Refer to Minimum Starting Ambient Temperature table for the recommended control set points for the appropriate control option.
- Verify that all exterior panels and the control panel doors are secured in place.

Table 42. Recommended operating setpoints, 20 to 120 ton units

Control	Control Setting	Recommended Setting
Discharge Air Control (VAV units only)	Discharge Air Setpoint	Set at design discharge (supply) air temperature; default setting = 55° F
	Reset Setpoint	Set at maximum amount of allowable reset for discharge air setpoint.
Chiller Control (EVP units only) Freezestat	Leaving Fluid Setpoint	Set at design leaving chilled water temperature (default) 44° F
	Reset Setpoint	Set at maximum amount of allowable reset for leaving fluid setpoint.
Freezestat	Low Limit Solution Temperature	Set at 5° F Minimum above the Chilled Solution Freeze Temperature

Note: For "No Controls" Units, see System Engineer.



Maintenance

Monthly Maintenance

Air Handling Equipment

⚠ WARNING

Hazardous Voltage!

Failure to disconnect power before servicing could result in death or serious injury.

Disconnect all electric power, including remote disconnects before servicing. Follow proper lockout/tagout procedures to ensure the power can not be inadvertently energized. Verify that no power is present with a voltmeter.

Before completing the following checks, turn the system control circuit switch 1S1 to the "Off" position. Open the main power disconnect switch for the Condensing Unit and Air Handling Unit and "lock it" in the "Off" position before removing any access panels.

- Inspect the return air filters. Clean or replace them if necessary.
- Check the evaporator drain pan and condensate piping to ensure that there are no blockages.
- Inspect the evaporator coils for dirt. If the coils appear dirty, clean them according to the instructions described in "Coil Cleaning," p.56,".
- Inspect the economizer damper hinges and pins (if applicable) to ensure that all moving parts are securely mounted. Clean the blades as necessary.
- Verify that all damper linkages move freely. Lubricate with white grease, if necessary.
- Check Supply Fan motor bearings. Repair or replace the motor as necessary.
- Check the fan shaft bearings for wear. Replace the bearings as necessary.
- Lubricate supply fan bearings. Contact equipment manufacturer for recommended greases.

NOTICE

Bearing Damage!

Over lubrication could result in as much damage to fan bearings as not enough grease.

To prevent damage to fan bearings, do not over lubricate.

Important: Use a hand grease gun to lubricate bearings. Add grease until a light bead appears all around the seal.

After greasing the bearings, check the setscrews to ensure that the shaft is held securely to the bearings and fan wheels. Make sure that all bearing supports are tight.

- Check the supply fan belt(s). If the belts are frayed or worn, replace them.
- Verify that all wire terminal connections are tight.
- Inspect unit for unusual conditions (e.g., loose access panels, leaking piping connections, etc.)
- When checks are complete, verify all retaining screws are reinstalled in unit access panels.

Condensing Unit

⚠ WARNING

Rotating Components!

Failure to disconnect power before servicing could result in rotating components cutting and slashing technician which could result in death or serious injury.

Disconnect all electric power, including remote disconnects before servicing. Follow proper lockout/tagout procedures to ensure the power can not be inadvertently energized.

- Manually rotate the condenser fans to ensure free movement and check motor bearings for wear. Verify that all of the fan mounting hardware is tight.
- Verify that all wire terminal connections are tight.
- Inspect the condenser coils for dirt and foreign debris. If the coils appear dirty, clean them according to the instructions described in Coil Cleaning section.
- Inspect the compressor and condenser fan motor contactors. If the contacts appear severely burned or pitted, replace the contactor. Do not clean the contacts.
- Check the compressor oil level. (Compressors "Off")

Coil Cleaning

NOTICE

Damaging Coil Cleaners!

Coil cleaners can damage roofs, surrounding buildings, vehicles, etc.

Cleaning substances should be checked to ensure that they will not cause damage to surroundings.

Coils and roof (if applicable) should be rinsed thoroughly. Do not spray coil cleaners in windy conditions.

Regular coil maintenance, including annual cleaning, enhances unit's operating efficiency by minimizing:

- compressor head pressure and amperage draw;
- water carryover;
- fan brake horsepower; and,
- static pressure losses.

At least once each year—or more often if the unit is located in a "dirty" environment — clean the microchannel

condenser using the instructions outlined below. Be sure to follow these instructions as closely as possible to avoid damaging the coils.

To clean refrigerant coils, use a soft brush and a sprayer.

Note: *DO NOT use any detergents with microchannel condenser coils. Pressurized water or air ONLY.*

1. Remove enough panels from the unit to gain safe access to coils..

⚠ WARNING

No Step Surface!

Failure to follow instruction below could result in death or serious injury.

Do not walk on the sheet metal drain pan. Walking on the drain pan could cause the supporting metal to collapse and result in the operator/technician falling.

***Important:** Bridging between the main supports required before attempting to enter into the unit. Bridging may consist of multiple 2 by 12 boards or sheet metal grating.*

2. Straighten any bent coil fins with a fin comb.
3. For accessible areas, remove loose dirt and debris from both sides of the coil. For dual row microchannel condenser coil applications, seek pressure coil wand extension through the local Trane Parts Center.
Note: *DO NOT use any detergents with microchannel coils. Pressurized water or air ONLY.*
4. Pour the cleaning solution into the sprayer. If a high-pressure sprayer is used:
 - a. The minimum nozzle spray angle is 15 degrees.
 - b. Do not allow sprayer pressure to exceed 600 psi.
 - c. Spray the solution perpendicular (at 90 degrees) to the coil face.
5. Spray the leaving-airflow side of the coil first; then spray the opposite side of the coil. For evaporator and reheat coils, allow the cleaning solution to stand on the coil for five minutes.
6. Rinse both sides of the coil with cool, clean water.
7. Inspect both sides of the coil; if it still appears to be dirty, repeat [Step 6](#) and [Step 7](#).
8. Reinstall all of the components and panels removed in [Step 1](#); then restore power to the unit.
9. For evaporator and reheat coils, use a fin comb to straighten any coil fins which were inadvertently bent during the cleaning process.

Microchannel Condenser Coil Repair and Replacement

If microchannel condenser coil repair or replacement is required, see *Unitary Light and Large Commercial Units General Service Bulletin* (RT-SVB83*-EN) for further details.

EVP Remote Evaporator Chiller

The brazed plate evaporator is difficult to clean should it become plugged with debris so proper installation and maintenance of the inlet water strainer is important. Particles larger than 0.039-inch entering the heat exchanger could block flow passages causing a failure. Indications of a plugged BPHE evaporator include “wet” suction due to lack of heat exchange, loss of superheat control, depressed discharge superheat (superheat less than 63°F), compressor oil dilution and/or starvation and premature compressor failure.

Minimum water flow rate must be maintained to avoid laminar flow, potential evaporator freezing, scaling and poor temperature control.

NOTICE

Heat Exchanger Damage!

Freezing and heat exchanger damage could occur if water flow is interrupted.

Do not stop water flow with the refrigeration system running.

Maximum water flow rate must not be exceeded to avoid possible erosion.

Water Strainer Maintenance

To protect the evaporator and for maximum efficiency, the strainer must be cleaned. A differential pressure gauge installed across the inlet and outlet will indicate pressure loss due to clogging and may be used as a guide to determine when cleaning is required. Normally when differential pressure reaches 5 to 10 psi, the screen must be cleaned. To clean, open and flush out until any sediment is removed.

EVP Evaporator Replacement

If the evaporator requires replacement, it is very important that the new evaporator be replaced correctly and with the correct refrigerant and water piping connections. The refrigerant inlet/liquid connection is at the bottom of the evaporator and the refrigerant outlet/suction connection is at the top of the evaporator and both are on the same side. Pay particular attention to evaporators with dual circuits. Avoid cross-circuiting when installing the new evaporator. Proper brazing techniques for dissimilar materials must be followed, see “[Brazing Procedures](#),” p. 60.

Water Loop

If the water loop is drained for an extended period, pipe sections between the strainer and the heat exchanger should be cleaned or replaced, to prevent rust buildup from entering the chiller.

Scroll Compressor

Operational Sounds

The following discussion describes some of the operational sounds of Trane R-410A/R-454B scroll compressors. These sounds do not affect the operation or reliability of the compressor.

Shutdown

When a Scroll compressor shuts down, the gas within the scroll expands and causes momentary reverse rotation until the discharge check valve closes. This results in a "flutter" type sound.

Low Ambient Start-Up

When the compressor starts up under low ambient conditions, the initial flow rate of the compressor is low due to the low condensing pressure. This causes a low differential across the thermal expansion valve that limits its capacity. Under these conditions, it is not unusual to hear the compressor rattle until the suction pressure climbs and the flow rate increases.

Failure Diagnosis and Replacement

CSHN and CSHP compressors (used in 80 to 120 ton units) do include a module in each compressor junction box that recognizes certain fault conditions. See "[Unit Description](#)," p. 9 for protection features included. For more detailed information regarding compressor failure diagnosis and replacement of scroll compressors, refer to *Service Guide - Compressor Replacement Recommendations* (PART-SVG002*-EN) and *CSHD and CSHN/CSHL Compressors Installation and Service* (COM-SVN01*-EN).

Compressor Circuit Breakers

Each compressor is protected by a circuit breaker. A tripped circuit breaker does not necessarily mean a compressor has failed. Verify that simpler problems do not exist including: low pressure, high pressure, discharge temperature, or power supply phasing and voltage issues. On 80- to 120-ton units, there is also a ventilation fan in the control box that operates when high outdoor ambient temperature is present. A tripped circuit breaker may indicate this fan is not operating properly. Refer to the unit schematics to troubleshoot the ventilation fan circuit. If circuit breaker replacement is necessary, please refer to the circuit breaker nameplate to identify the part number and manufacturer. A replacement circuit breaker must maintain the same "must hold / must trip" values and ambient de-rate curve. If needed, contact the circuit breaker manufacturer for the datasheet that outlines those specifications.

Refrigerant Evacuation and Charging

⚠ WARNING

Refrigerant under High Pressure!

Failure to follow instructions below could result in an explosion which could result in death or serious injury or equipment damage.

System contains refrigerant under high pressure. Recover refrigerant to relieve pressure before opening the system. See unit nameplate for refrigerant type. Do not use non-approved refrigerants, refrigerant substitutes, or refrigerant additives.

⚠ WARNING

R-454B Flammable A2L Refrigerant!

Failure to use proper equipment or components as described below could result in equipment failure, and possibly fire, which could result in death, serious injury, or equipment damage.

The equipment described in this manual uses R-454B refrigerant which is flammable (A2L). Use ONLY R-454B rated service equipment and components. For specific handling concerns with R-454B, contact your local representative.

The compressor manifold system was designed to provide proper oil return to each compressor. The refrigerant manifold must not be modified in any way. Should a compressor replacement become necessary and a suction line filter drier is to be installed, install it at least the minimum distance upstream of the suction manifold tee as shown in illustrations shown in Suction Line Filter section. For recommended suction filter selections, see *Tube Size and Component Selection IntelliCore™ Split Systems (20 to 120 Tons) R-454B Refrigerant Microchannel Condensers Application Guide* (SS-APG018*-EN) for R-454B and *Tube Size and Component Selection RAUJ Split Systems (20 to 120 Tons) R-410A Refrigerant Microchannel Condensers Application Guide* (SS-APG012*-EN) for R-410A.

NOTICE

Compressor Damage!

Altering the manifold piping could cause oil return problems and compressor failure.

Do not alter compressor manifold piping.

⚠ WARNING

R-410A Refrigerant under Higher Pressure than R-22!

Failure to use proper equipment or components as described below, could result in equipment failing and possibly exploding, which could result in death, serious injury, or equipment damage.

The units described in this manual use R-410A refrigerant which operates at higher pressures than R-22. Use ONLY R-410A rated service equipment or components with these units. For specific handling concerns with R-410A, please contact your local Trane representative.

NOTICE

Compressor Damage!

Failure to follow these instructions could result in compressor failure.

If it becomes necessary to remove or recharge the system with refrigerant, it is important that the following actions are taken.

- To prevent cross contamination of refrigerants and oils, use only dedicated refrigerant service equipment.
- Disconnect unit power before evacuation and do not apply voltage to compressor while under vacuum.
- Due to presence of POE oil, minimize system open time. Do not exceed 1 hour.
- When recharging R-410A/R-454B refrigerant, follow procedures outlined in the Start-Up section of this IOM.
- Allow the crankcase heater to operate a minimum of 8 hours before starting the unit.

Important:

- Do not spill compressor oil. Refrigerant oil is detrimental to some roofing materials. Care must be taken to protect the roof from oil leaks or spills.
- Do not release refrigerant to the atmosphere! If adding or removing refrigerant is required, the service technician must comply with all federal, state, and local laws.

Compressor Replacement

Discoloration of the oil indicates that an abnormal condition has occurred. If the oil is dark and smells burnt, it has overheated, which could be a result of the following:

- compressor operating at extremely high condensing temperatures
- high superheat
- compressor mechanical failure

OR

- occurrence of a motor burnout

If a motor burnout is suspected, use an acid test kit (KIT15496) to check the condition of the oil. Test results will indicate an acid level has exceeded the limit if a burnout occurred. Oil test kits must be used for POE oil (OIL00079 for a quart container or OIL00080 for a gallon container) to determine whether the oil is acidic. If a motor burnout has occurred, change the oil in all compressors in a tandem or trio set.

YAS 2-Stage Compressors (20 and 25 Ton)

For 20 and 25 ton systems which use 2-stage unloading scrolls please remove oil using a suction or pump device through the oil fill valve fitting. Use a dedicated device for removing oil. It is a good practice to flush the suction device with clean oil prior to use.

Place a catch pan under the oil equalizer line to catch the oil that will come out of the compressor(s) when the oil equalizer tube is removed.

For adding oil to these manifold sets, an oil fill port is located on the oil equalizer line, as shown in the figure below.

Figure 92. YAS 2-stage compressors

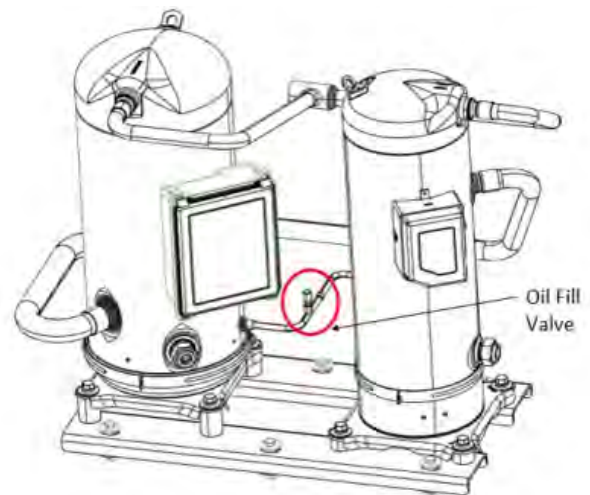

CSHE/CSHD Compressors (30 to 60 Ton)

For CSHE/CSHD compressors, this will require that the oil be removed using a suction or pump device through the oil equalizer Rotolock fitting, see [Figure 93, p. 117](#). Use a dedicated device for removing oil. It is good practice to flush the suction device with clean oil prior to use. Place a catch pan under the oil equalizer Rotolock connection fitting on the compressor to catch the oil that will come out of the compressor when the oil equalizer tube is removed from the compressor.

Prior to reinstalling the oil equalizer line to each compressor, replace the Teflon gasket on the oil equalizer Rotolock fitting on each compressor. See [Figure 94, p.](#)

117. Torque the Rotolock nut to the values listed in Table 45, p. 117.

Charge the new oil into the Schrader valve on the shell of the compressor. Due to the moisture absorption properties of POE oil, do not use POE oil from a previously opened container. Also discard any excess oil from the container that is not used.

CSHP/CSHN Compressors (80 to 120 Ton)

CSHP/CSHN compressors have an oil drain valve, see Figure 93, p. 117, which allows the oil to be drained out of the compressor. After the refrigerant has been recovered, pressurize the system with nitrogen to help remove the oil from the compressor.

Figure 93. Scroll compressor external features

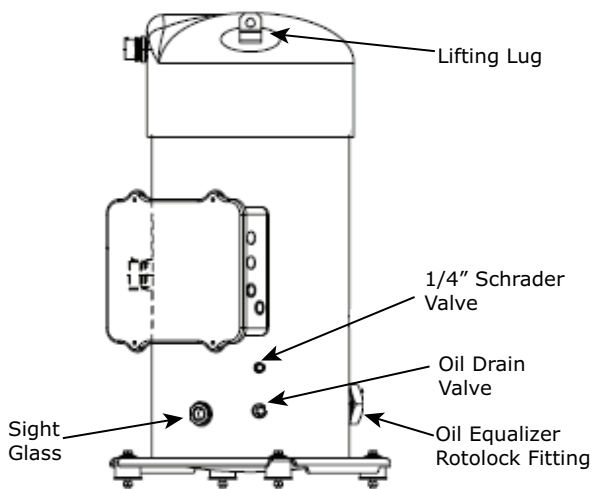
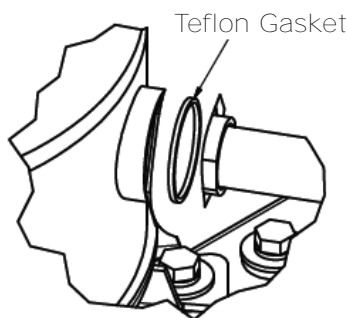

Figure 94. Teflon gasket



Charge the new oil into the Schrader valve or oil drain valve on the shell of the compressor. Due to the moisture absorption properties of POE oil, do not use POE oil from a previously opened container. Also discard any excess oil from the container that is not used.

Table 44. Oil charge per compressor

Compressor		Pints
R-454B	CSHE 088 thru 177	7.0
	CSHP 178 thru 237	14.2
R-410A	CSHD 110 thru 183	7.0
	CSHN 176 thru 250	14.2

Table 45. Torque requirements for Rotolock fittings

Compressor	Torque (ft-lbs)
CSHE*/CSHD*	64 +/- 12
CSHP*/CSHN*	100 +/- 10

Note: Always replace gasket when reassembling oil equalizer lines.

Electrical Phasing

It is very important to review and follow the Electrical Phasing procedure described in the startup procedure of this document.

If the compressors are allowed to run backward for even a very short period of time, internal compressor damage could occur and compressor life could be reduced.

If a scroll compressor is rotating backwards, it will not pump, make a loud rattling sound, low side shell gets hot, and draw 1/2 expected amps. Immediately shut-off the unit. Ensure that unit phasing is correct. If the incorrect phasing is determined to be at one compressor, interchange any two compressor leads to correct the motor phasing.

Precision Suction Restrictor

RAUK tandems with unequal compressors and all RAUK trios use precision suction restrictors to balance the oil levels in the compressors. For manifolded compressors in RA units, this restrictor is placed in the compressor indicated in . When replacing this compressor, it is imperative that the proper restrictor is selected from those provided with the replacement compressor.

When the compressors are restarted verify that correct oil levels are obtained when all compressors are running in a manifold set.

Figure 95. Precision suction restrictor

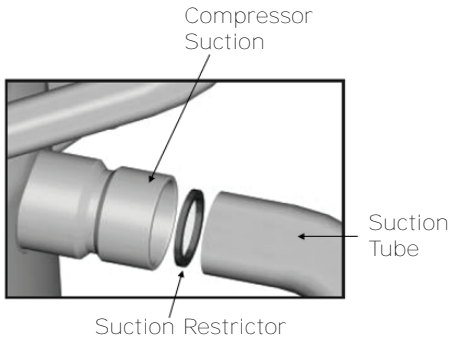

Table 46. Suction restrictor location – R-410A

Unit Size	Circuit	Compressor
25 Ton	1A	CSHD125
50 Ton	1A, 2A	CSHD142
80 Ton	1C, 2C	CSHD176
100 Ton	1A, 1B, 2A, 2B	CSHD184
120 Ton	1C, 2C	CSHD250

Table 47. Suction restrictor location – R-454B

Unit Size	Circuit	Compressor
20 Ton	—	—
25 Ton	—	—
30 Ton	—	—
40 Ton	1A, 2A	CSHE117
50 Ton	1A, 2A	CSHE132
60 Ton	—	—
80 Ton	1C, 2C	CSHP178
100 Ton	1C, 2C	CSHP237
120 Ton	1A, 1B, 2A, 2B	CSHP237

Suction Line Filter

Minimum 16" for CSHE/CSHD straight unobstructed piping between the Suction Filter/Drier and the Tee

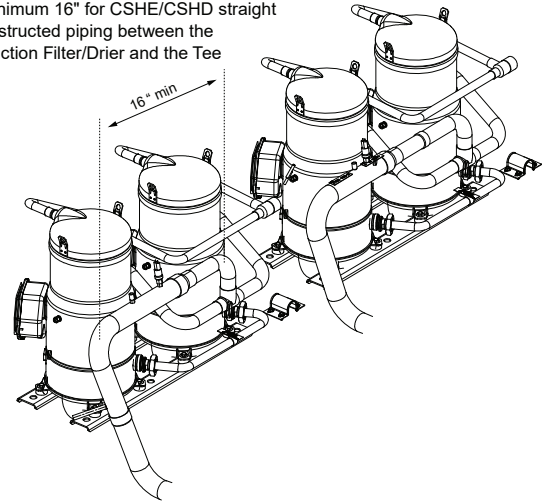

Minimum 25" for CSHP/CSHN straight unobstructed piping between the suction filter/drier and tee

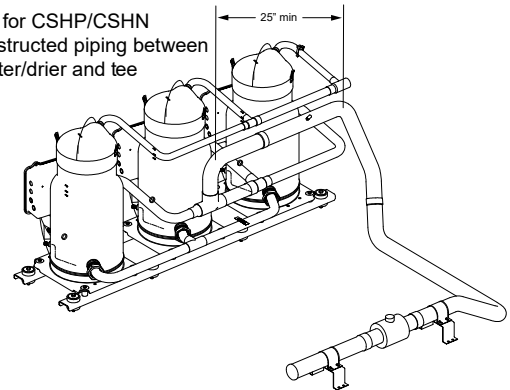

Fall Restraint — Condenser Roof

⚠ WARNING

Falling Off Equipment!

Failure to follow instructions below could result in death or serious injury.

This unit is built with fall restraint slots located on unit top that **MUST** be used during servicing. These slots are to be used with fall restraint equipment that will not allow an individual to reach the unit edge. However such equipment will **NOT** prevent falling to the ground, as they are **NOT** designed to withstand the force of a falling individual.

This unit is built with fall restraint slots located on unit top that must be used during servicing. See figures below.

Figure 96. Fall restraint slot

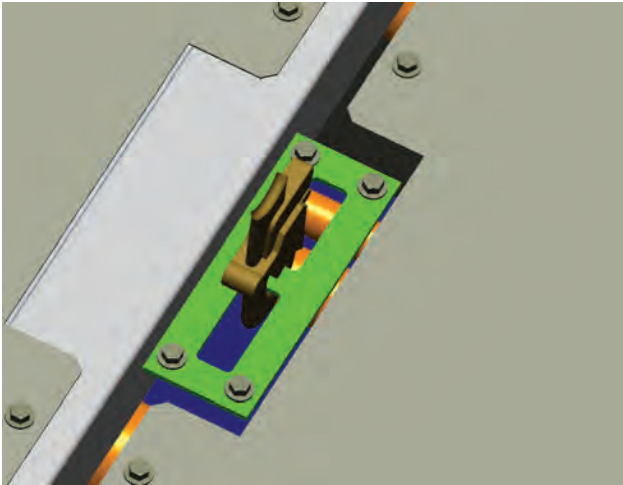
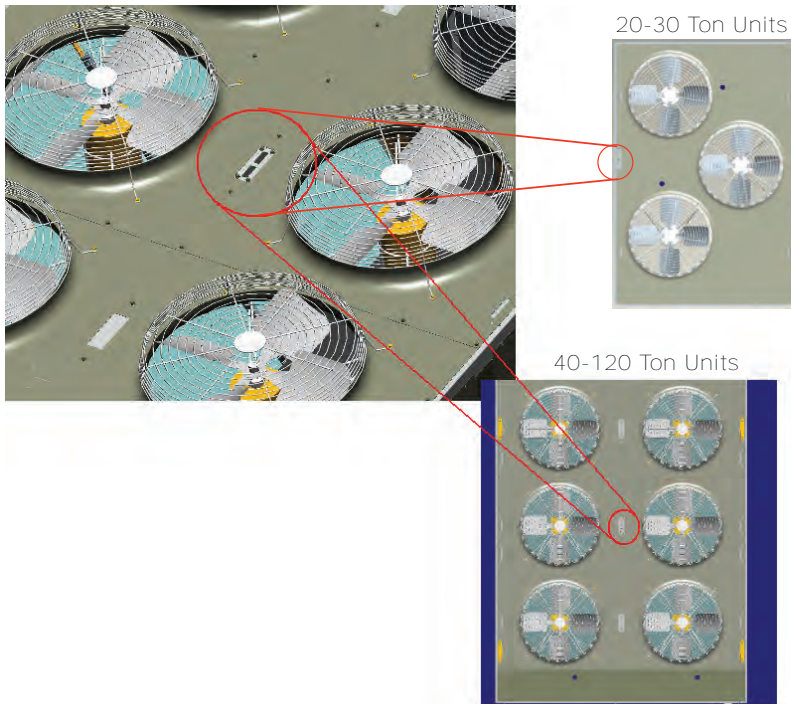

Figure 97. Fall restraint slot location





Warranty and Liability Clause

Commercial Equipment Rated 20 Tons and Larger and Related Accessories

*Optional Extended Warranties are available for compressors and heat exchangers of Combination Gas-Electric Air Conditioning Units.

Products Covered

This warranty* is extended by Trane Inc. and applies only to commercial equipment rated 20 Tons and larger and related accessories.

The Company warrants for a period of 12 months from initial start-up or 18 months from date of shipment, whichever is less, that the Company products covered by this order (1) are free from defects in material and workmanship and (2) have the capacities and ratings set forth in the Company's catalogs and bulletins, provided that no warranty is made against corrosion, erosion or deterioration. The Company's obligations and liabilities under this warranty are limited to furnishing f.o.b. factory or warehouse at Company designated shipping point, freight allowed to Buyer's city (or port of export for shipment outside the conterminous United States) replacement equipment (or at the option of the Company parts therefore) for all Company products not conforming to this warranty and which have been returned to the manufacturer. The Company shall not be obligated to pay for the cost of lost refrigerant. No liability whatever shall attach to the Company until said products have been paid for and then said liability shall be limited to the purchase price of the equipment shown to be defective.

The Company makes certain further warranty protection available on an optional extra-cost basis. Any further warranty must be in writing, signed by an officer of the Company.

The warranty and liability set forth herein are in lieu of all other warranties and liabilities, whether in contract or in negligence, express or implied, in law or in fact, including implied warranties of merchantability and fitness for particular use. In no event shall the Company be liable for any incidental or consequential damages.

THE WARRANTY AND LIABILITY SET FORTH HEREIN ARE IN LIEU OF ALL OTHER WARRANTIES AND LIABILITIES, WHETHER IN CONTRACT OR IN NEGLIGENCE, EXPRESS OR IMPLIED, IN LAW OR IN FACT, INCLUDING IMPLIED WARRANTIES OF MERCHANTABILITY AND FITNESS FOR PARTICULAR USE, IN NO EVENT SHALL WARRANTOR BE LIABLE FOR ANY INCIDENTAL OR CONSEQUENTIAL DAMAGES.

Manager - Product Service

Trane Inc.

Clarksville, Tn 37040-1008

PW-215-2688



Wiring Diagrams

Note: Published unit wiring diagrams (individual, separate diagrams for unitary product lines) are available via e-Library.

Drawing Number	Description
12134862	SCHEMATIC; SHEET 1, POWER, RA, DISTRIBUTION
12134863	SCHEMATIC; SHEET 2, POWER, RA, 80-120T
12134864	SCHEMATIC; SHEET 2, POWER, RA, 20-60T
12134865	SCHEMATIC; SHEET 3, CONTROLS, RA, UNIT
12134866	SCHEMATIC; SHEET 4, CONTROLS, RA, REFRIGERATION #1
12134867	SCHEMATIC; SHEET 5, CONTROLS, RA, REFRIGERATION #2
12134868	SCHEMATIC; SHEET 6, CONTROLS, RA, CUSTOMER #1
12134869	SCHEMATIC; SHEET 7, CONTROLS, RA, CUSTOMER #2
12134870	DIAGRAM; SHEET 8, COMPONENT LOCATION, RA, 80-120T
12134871	DIAGRAM; SHEET 8, COMPONENT LOCATION, RA, 40-60T
12134872	DIAGRAM; SHEET 8, COMPONENT LOCATION, RA, 20-30T
12134873	DIAGRAM; SHEET 9, COMPONENT LOCATION, RA, CBOX ^(a)
12135043	SCHEMATIC; EVP REMOTE PANEL

^(a) Fuse replacement table located on control box component location diagram.



Notes

Trane - by Trane Technologies (NYSE: TT), a global innovator - creates comfortable, energy efficient indoor environments for commercial and residential applications. For more information, please visit trane.com or tranetechnologies.com.

Trane has a policy of continuous product and product data improvements and reserves the right to change design and specifications without notice. We are committed to using environmentally conscious print practices.

SS-SVX091E-EN 17 Jul 2026
Supersedes SS-SVX091D-EN (February 2026)

©2026 Trane