

Installation, Operation, and Maintenance
Split System Air Conditioners
Odyssey™ with Symbio™
Controls
Heat Pump Condenser, R-454B 6 to 20 Tons

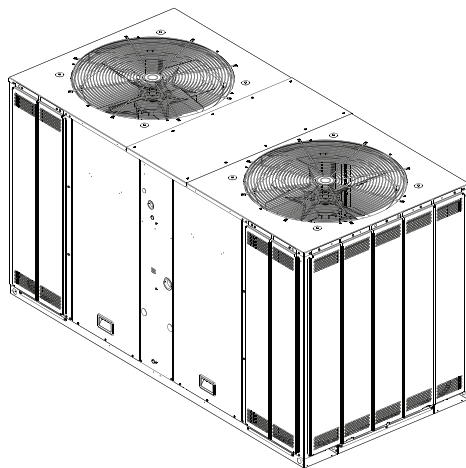

(60 Hz)

TWA072K*A

TWA072K*D

TWA090K*A

TWA090K*D

TWA120K*A

TWA120K*D

TWA180K*D

TWA240K*D

▲ SAFETY WARNING

Only qualified personnel should install and service the equipment. The installation, starting up, and servicing of heating, ventilating, and air-conditioning equipment can be hazardous and requires specific knowledge and training. Improperly installed, adjusted or altered equipment by an unqualified person could result in death or serious injury. When working on the equipment, observe all precautions in the literature and on the tags, stickers, and labels that are attached to the equipment.

Introduction

Read this manual thoroughly before operating or servicing this unit.

Warnings, Cautions, and Notices

Safety advisories appear throughout this manual as required. Your personal safety and the proper operation of this machine depend upon the strict observance of these precautions.

The three types of advisories are defined as follows:



Indicates a potentially hazardous situation which, if not avoided, could result in death or serious injury.



Indicates a potentially hazardous situation which, if not avoided, could result in minor or moderate injury. It could also be used to alert against unsafe practices.

NOTICE

Indicates a situation that could result in equipment or property-damage only accidents.

Important Environmental Concerns

Scientific research has shown that certain man-made chemicals can affect the earth's naturally occurring stratospheric ozone layer when released to the atmosphere. In particular, several of the identified chemicals that may affect the ozone layer are refrigerants that contain Chlorine, Fluorine and Carbon (CFCs) and those containing Hydrogen, Chlorine, Fluorine and Carbon (HCFCs). Not all refrigerants containing these compounds have the same potential impact to the environment. Trane advocates the responsible handling of all refrigerants.

Important Responsible Refrigerant Practices

Trane believes that responsible refrigerant practices are important to the environment, our customers, and the air conditioning industry. All technicians who handle refrigerants must be certified according to local rules. For the USA, the Federal Clean Air Act (Section 608) sets forth the requirements for handling, reclaiming, recovering and recycling of certain refrigerants and the equipment that is used in these service procedures. In addition, some states or municipalities may have additional requirements that must also be adhered to for responsible management of refrigerants. Know the applicable laws and follow them.

⚠ WARNING

Proper Field Wiring and Grounding Required!

Failure to follow code could result in death or serious injury.

All field wiring MUST be performed by qualified personnel. Improperly installed and grounded field wiring poses FIRE and ELECTROCUTION hazards. To avoid these hazards, you MUST follow requirements for field wiring installation and grounding as described in NEC and your local/state/national electrical codes.

⚠ WARNING

Personal Protective Equipment (PPE) Required!

Failure to wear proper PPE for the job being undertaken could result in death or serious injury.

Technicians, in order to protect themselves from potential electrical, mechanical, and chemical hazards, **MUST follow precautions in this manual and on the tags, stickers, and labels, as well as the instructions below:**

- **Before installing/servicing this unit, technicians MUST put on all PPE required for the work being undertaken (Examples; cut resistant gloves/sleeves, butyl gloves, safety glasses, hard hat/bump cap, fall protection, electrical PPE and arc flash clothing). ALWAYS refer to appropriate Safety Data Sheets (SDS) and OSHA guidelines for proper PPE.**
- **When working with or around hazardous chemicals, ALWAYS refer to the appropriate SDS and OSHA/GHS (Global Harmonized System of Classification and Labelling of Chemicals) guidelines for information on allowable personal exposure levels, proper respiratory protection and handling instructions.**
- **If there is a risk of energized electrical contact, arc, or flash, technicians MUST put on all PPE in accordance with OSHA, NFPA 70E, or other country-specific requirements for arc flash protection, PRIOR to servicing the unit. NEVER PERFORM ANY SWITCHING, DISCONNECTING, OR VOLTAGE TESTING WITHOUT PROPER ELECTRICAL PPE AND ARC FLASH CLOTHING. ENSURE ELECTRICAL METERS AND EQUIPMENT ARE PROPERLY RATED FOR INTENDED VOLTAGE.**

⚠ WARNING**Follow EHS Policies!**

Failure to follow instructions below could result in death or serious injury.

- All Trane personnel must follow the company's Environmental, Health and Safety (EHS) policies when performing work such as hot work, electrical, fall protection, lockout/tagout, refrigerant handling, etc. Where local regulations are more stringent than these policies, those regulations supersede these policies.
- Non-Trane personnel should always follow local regulations.

⚠ WARNING**R-454B Flammable A2L Refrigerant!**

Failure to use proper equipment or components as described below could result in equipment failure, and possibly fire, which could result in death, serious injury, or equipment damage.

The equipment described in this manual uses R-454B refrigerant which is flammable (A2L). Use ONLY R-454B rated service equipment and components. For specific handling concerns with R-454B, contact your local representative.

⚠ WARNING**Refrigerant under High Pressure!**

Failure to follow instructions below could result in an explosion which could result in death or serious injury or equipment damage.

System contains refrigerant under high pressure. Recover refrigerant to relieve pressure before opening the system. See unit nameplate for refrigerant type. Do not use non-approved refrigerants, refrigerant substitutes, or refrigerant additives.

⚠ WARNING**Explosion Hazard!**

Failure to follow instructions below could result in an explosion which could result in death or serious injury, and equipment damage.

NEVER bypass system safeties in order to pump down the unit component's refrigerant into the microchannel heat exchanger (MCHE) coil. Do NOT depress the compressor contactor since it effectively bypasses the high-pressure control.

Copyright

This document and the information in it are the property of Trane, and may not be used or reproduced in whole or in part without written permission. Trane reserves the right to revise this publication at any time, and to make changes to its content without obligation to notify any person of such revision or change.

Trademarks

All trademarks referenced in this document are the trademarks of their respective owners.

Product Safety Information

This appliance is not intended for use by persons (including children) with reduced physical, sensory or mental capabilities, or lack of experience and knowledge, unless they have been given supervision or instruction concerning use of the appliance by a person responsible for their safety. Children should be supervised to ensure that they do not play with the appliance.

Maximum altitude of use 3000 meters.

This appliance incorporates an earth connection for functional purposes only.

Table of Contents

Model Number Description	5	Refrigerant Piping Procedures (Indoor Unit)	23
Heat Pump Condenser	5	Leak Check	24
General Information	6	System Evacuation	24
Unit Description	6	Insulating and Isolating Refrigerant Lines	25
A2L Information	7	Refrigerant Charging Procedure	25
A2L Work Procedures	7	Charging Levels	25
Servicing	7	Liquid Charging	27
Leak Detection	8	Electrical Wiring	27
Refrigerant Removal and Evacuation	8	Unit Power Supply	27
Refrigerant Charging	8	Low Voltage Wiring	28
Decommissioning	9	Symbio™ Controls	28
A2L Application Considerations	9	Field Wiring	29
Ignition Sources in Ductwork	9	Refrigerant Circuit	29
Ignition Sources in Unit	9	Pre-Start	31
Minimum Room Area Limits (Refrigerant charge greater than 3.91 lb per circuit)	10	Control Circuit Features	31
Leak Detection System(Refrigerant charge greater than 3.91 lb per circuit)	12	Discharge Temperature Limit (DTL)	31
Field Piping Installation and Charging	12	Low Outdoor Ambient Cooling	31
Pre-Installation	13	Evaporator Defrost Control (EDC)	31
Unit Inspection	13	Low Pressure Cut-Out (LPC)	31
Inspection Checklist	13	High Pressure Cut-Out (HPCO)	31
Lifting Recommendations	13	Internal Overload Protector (IOL)	31
Clearances	13	Refrigerant Leak Detector Input	31
Unit Mounting	13	Troubleshooting	32
Structural Preparation	14	Leak Detection System	32
Rooftop Mounting	14	Service Test Mode	33
Ground Level Mounting	14	Maintenance	34
Snow Belt Recommendations	14	Monthly	34
Installation Checklist	14	Annually (Cooling Season)	34
Refrigerant Piping	14	Coil Cleaning	34
Electrical Wiring	14	Tube and Fin	34
Maintenance Log	35	Charging Data and Pressure Curves	36
Dimensional Data	15	Wiring Diagram Matrix and Device Location	37
Heat Pump	15	Warranty	38
Weights	21	For Commercial Unitary Equipment Rated 25 Tons and Under and Related Accessories	38
Heat Pump Condenser	21	Basic Warranty	38
Installation	22	Exclusions and Limitations	38
Refrigerant Piping Guidelines	22		
Refrigerant Piping Procedures (Outdoor Units)	22		

Model Number Description

Heat Pump Condenser

Digit 1, 2, 3 — Unit Function

TWA = Split System Heat Pump

Digit 4, 5, 6 — Tonnage

072 = 6 Tons (60 Hz)

090 = 7.5 Tons (60 Hz)

120 = 10 Tons (60 Hz)

180 = 15 Tons (60 Hz)

240 = 20 Tons (60 Hz)

Digit 7 — Refrigerant

K = R-454B

Digit 8 — Voltage

3 = 208-230 Vac - 3 PH (60Hz)

4 = 460 Vac - 3 PH (60Hz)

Digit 9 — Refrigeration Circuit/Stage

A = 1 Compressor/1 Line/1 Stage (Single)

D = 2 Compressors/2 Line/2 Stage (Dual)

Digit 10 — Major Design Sequence

A = Rev A

Digit 11 — Minor Design Sequence

A = Rev A

Digit 12, 13 — Service Digits

**

Digit 14 — Efficiency Generation

B = Generation B

Digit 15 — Controls

S = Symbio™

Digit 16 — None

0 = None

Digit 17 — Coil Protection

0 = Standard Coil

1 = Standard Coil w/ Coil Guard

2 = Black Epoxy Pre-Coated Condenser Coil (FIN/TUBE)

3 = Black Epoxy Pre-Coated Condenser Coil with Coil Guard (FIN/TUBE)

Digit 18, 19, 20 — None

0 = None

Digit 21 — Communications Options

0 = No Option

1 = Advanced Diagnostics and BACnet® BAS

2 = Advanced Diagnostics and LonTalk® Communications Interface (LCI)

Digit 22 to 40 — None

0 = None

General Information

This manual describes proper installation, operation, and maintenance procedures for air-cooled systems. By carefully reviewing the information within this manual and following the instructions, the risk of improper operation and/or component damage will be minimized. It is important that periodic maintenance be performed to help assure trouble free operation. Should equipment failure occur, contact a qualified service organization with qualified, experienced HVAC technicians to properly diagnose and repair this equipment.

Important: All phases of this installation must comply with the NATIONAL, STATE and LOCAL CODES. In addition to local codes, the installation must conform with National Electric Code -ANSI/ NFPA NO. 70 LATEST REVISION.

Any individual installing, maintaining, or servicing this equipment must be properly trained, licensed and qualified.

Important: Do not remove the VFD without first contacting technical support! For performance-related questions and diagnostic VFD support in North America, request Live Tech Support via the link: <https://support.trane.com/hc/en-us>. Any return or escalation to the VFD manufacturer requires a Trane Technical Support ticket number FIRST. Removal of the VFD prior to this step will void the unit's warranties.

Installation procedures should be performed in the sequence that they appear in this manual. Do not destroy

or remove the manual from the unit. The manual should remain weather-protected with the unit until all installation procedures are complete.

Note: It is not the intention of this manual to cover all possible variations in systems that may occur or to provide comprehensive information concerning every possible contingency that may be encountered during an installation. If additional information is required or if specific problems arise that are not fully discussed in this manual, contact your local sales office.

Use the "Installation Checklist," p. 14 provided in this manual to verify that all necessary installation procedures have been completed. Do not use the checklist as a substitute for reading the information contained in this manual. Read this entire manual before beginning installation procedures.

Unit Description

These condensers come with single and dual compressor options. Single compressor outdoor units feature a single refrigeration circuit requiring only one set of refrigerant lines. Dual compressor/dual circuit models give true stand-by protection; if one compressor fails, the second will automatically start-up. During light load conditions, only one compressor will operate to save energy.

A2L Information

A2L Work Procedures

⚠ WARNING

Risk of Fire — Flammable Refrigerant!

Failure to follow instructions below could result in death or serious injury, and equipment damage.

- To be repaired only by trained service personnel.
- Do not puncture refrigerant tubing.
- Dispose of properly in accordance with federal or local regulations.

⚠ WARNING

Refrigerant under High Pressure!

Failure to follow instructions below could result in an explosion which could result in death or serious injury or equipment damage.

System contains refrigerant under high pressure. Recover refrigerant to relieve pressure before opening the system. See unit nameplate for refrigerant type. Do not use non-approved refrigerants, refrigerant substitutes, or refrigerant additives.

⚠ WARNING

Hazardous Voltage!

Failure to disconnect power before servicing could result in death or serious injury.

Disconnect all electric power, including remote disconnects before servicing. Follow proper lockout/tagout procedures to ensure the power can not be inadvertently energized. Verify that no power is present with a voltmeter.

The units described in this manual use R-454B refrigerant. Use ONLY R-454B rated service equipment or components with these units. For specific handling concerns with R-454B, contact your local Trane representative.

Installation, repair, removal, or disposal should be performed by trained service personnel.

At all times, Trane's maintenance and service guidelines shall be followed. If in doubt, contact Trane technical support for assistance.

Service

Prior to initiating work on equipment, check the area with an appropriate refrigerant detector. Ensure the service personnel are properly trained regarding work in potentially toxic or flammable atmospheres. Ensure that the leak detection equipment being used is suitable for use with all applicable refrigerants, i.e. non-sparking, adequately

sealed, or intrinsically safe. Be aware that the refrigerant does not contain an odor.

If any hot work is to be conducted on the refrigerating equipment or any associated parts, appropriate fire extinguishing equipment shall be available on hand. A dry powder or CO₂ fire extinguisher should be located adjacent to the charging area.

At all times, Trane's maintenance and service guidelines shall be followed. If in doubt, contact Trane technical support for assistance.

All maintenance staff and others working in the local area shall be instructed on the nature of the work being carried out. Work in confined spaces shall be avoided.

Ignition Source Mitigation

Do not use any sources of ignition when working on the refrigeration system.

Keep all ignition sources, including cigarette smoking, away from the site of installation, repair, removal or disposal, during which refrigerant can potentially be released to the surrounding space.

Survey the area around the equipment before initiating work to ensure no flammable hazards or ignition risks are present.

"No Smoking" signs shall be displayed.

Do not use devices that can be a source of ignition to accelerate defrosting of components. Use only defrost and cleaning procedures recommended by Trane. Do not pierce or burn.

Ventilation

Ensure that the area is in the open or that it is adequately ventilated before breaking into the system or conducting any hot work. A degree of ventilation shall continue during the period that the work is carried out. The ventilation should safely disperse any released refrigerant and preferably expel it externally into the atmosphere. If present, check that the ventilation system, including outlets, are operating adequately and are not obstructed.

Refrigerating Equipment

Refrigerant piping or components should not be installed in locations where substances which may corrode them are present.

Check that equipment hazard markings are visible and legible. Replace them if they are not.

For equipment using secondary fluids, like water or glycol, check that refrigerant is not present in the secondary fluid loop before conducting any hot work.

Electrical Devices

Do not apply power to the circuit if a fault exists which compromises safety. If the fault cannot be corrected immediately, but it is necessary to continue operation, an

adequate temporary solution shall be used. This shall be reported to the owner of the equipment, so all parties are advised.

Initial safety checks shall include:

- Cabling is not subject to wear, corrosion, excessive pressure, vibration, sharp edges, or any other adverse environmental effects. Account for the effects of aging or continual vibration from sources such as compressors or fans.
- Capacitors are discharged. This shall be done in a safe manner to avoid possibility of sparking.
- No live electrical components and wiring are exposed while charging, recovering, or purging the system.
- Verify continuity of earth bonding.
- Replace electrical components with Trane replacement parts, or those meeting the same ratings and qualified for flame arrest protection, UL LZGH2 category.

Leak Detection

Never use an open flame to detect leaks. A halide torch should not be used. Use only approved leak detection methods per this instruction manual.

The following leak detection methods are deemed acceptable for all refrigerant systems.

Electronic leak detectors may be used to detect refrigerant leaks but, in the case of flammable refrigerants, the sensitivity may not be adequate, or may need re-calibration. (Detection equipment shall be calibrated in a refrigerant-free area.) Ensure that the detector is not a potential source of ignition and is suitable for the refrigerant used. Leak detection equipment shall be set at a percentage of the LFL gas (25% maximum) is confirmed.

Leak detection fluids are also suitable for use with most refrigerants but the use of detergents containing chlorine shall be avoided as the chlorine may react with the refrigerant and corrode the copper pipe-work.

Examples of leak detection fluids are:

- Bubble method
- Fluorescent method agents

If a leak is suspected, all naked flames shall be removed/ extinguished.

If a refrigerant leak is found which requires brazing, all refrigerant shall be recovered from the system, or isolated (by means of shut off valves) in a part of the system remote from the leak.

Refrigerant Removal and Evacuation

When breaking into the refrigerant circuit to make repairs – or for any other purpose – conventional procedures shall be used. However, for flammable refrigerants it is important that best practice be followed, since flammability is a consideration.

The following procedure shall be adhered to:

1. Safely remove refrigerant following local and national regulations.
2. Evacuate.
3. Purge the circuit with inert gas.
4. Evacuate (optional for A2L).
5. Continuously flush or purge with inert gas when using flame to open circuit.
6. Open the circuit.

Prior to refrigerant removal, open all appropriate valves, including solenoid and electronic expansion valves (EXVs). Use control settings, where available. When not available, manually open all electronically controlled valves using acceptable service procedures.

The recovery equipment shall be in good working order with instructions available. Equipment shall be suitable for the recovery of the flammable refrigerant. For specific handling concerns, contact the manufacturer. Ensure all hose connections are checked for tightness to avoid refrigerant leaks.

The refrigerant shall be recovered into the correct recovery cylinders if venting is not allowed by local and national codes. Do not mix refrigerants in recovery unit and especially not in cylinders.

Refrigerant recovery unit should be purged with an inert gas after each use or before using with a different refrigerant Class – for example, A2L to A1.

If compressors or compressor oils are to be removed, ensure that they have been evacuated to an acceptable level to make certain that flammable refrigerant does not remain within the lubricant. The compressor body shall not be heated by an open flame or other ignition sources to accelerate this process. When oil is drained from a system, it shall be carried out safely.

The system shall be purged with oxygen-free nitrogen to render the appliance safe for flammable refrigerants. This process might need to be repeated several times. Compressed air or oxygen shall not be used for purging refrigerant systems.

The system shall be vented down to atmospheric pressure to enable work to take place.

The outlet for the vacuum pump shall not be close to any potential ignition sources, and ventilation shall be available.

Refrigerant Charging

In addition to conventional charging procedures, the following requirements shall be followed.

- Ensure that contamination of different refrigerants does not occur when using charging equipment.
- Hoses or lines shall be as short as possible to minimize the amount of refrigerant contained in them.
- Cylinders shall be kept in an appropriate position according to the instructions.

- Ensure that the refrigerating system is earthed prior to charging the system with refrigerant.
- Label the system when charging is complete (if not already).
- Extreme care shall be taken not to overfill the refrigerating system.

Prior to recharging the system, it shall be pressure-tested with the appropriate purging gas. The system shall be leak-tested on completion of charging but prior to commissioning. A follow up leak test shall be carried out prior to leaving the site.

Prior to refrigerant charging, open all appropriate valves, including solenoid and electronic expansion valves (EXVs). Use control settings, where available. When not available, manually open all electronically controlled valves using acceptable service procedures.

Decommissioning

Before carrying out the decommissioning procedure, it is essential that the trained service personnel is completely familiar with the equipment and all its details. It is recommended good practice that all refrigerants are recovered safely. Prior to the task being carried out, an oil and refrigerant sample shall be taken in case analysis is required prior to re-use of recovered refrigerant. It is essential that electrical power is available before the task is commenced.

1. Become familiar with the equipment and its operation.
2. Isolate system electrically.
3. Before attempting the procedure, ensure that:
 - a. Mechanical handling equipment is available, if required, for handling refrigerant cylinders.
 - b. All personal protective equipment is available and being used correctly.
 - c. The recovery process is supervised at all times by a competent person.
 - d. Recovery equipment and cylinders conform to the appropriate standards.
4. Pump down refrigerant system, if possible.
5. If a vacuum is not possible, make a manifold so that refrigerant can be removed from various parts of the system.
6. Make sure that cylinder is situated on the scales before recovery takes place.
7. Start the recovery machine and operate in accordance with instructions.
8. Do not overfill cylinders (no more than 80% volume liquid charge).
9. Do not exceed the maximum working pressure of the cylinder, even temporarily.
10. When the cylinders have been filled correctly and the process completed, make sure that the cylinders and

the equipment are removed from site promptly and all isolation valves on the equipment are closed off.

11. Recovered refrigerant shall not be charged into another refrigerating system unless it has been cleaned and checked.
12. When equipment has been decommissioned, attach a signed label which includes the date of decommissioning.

A2L Application Considerations

This product is listed to UL standard 60335-2-40, Household and Similar Electrical Appliances – Safety – Part 2-40: Particular Requirements for Electrical Heat Pumps, Air-Conditioners and Dehumidifiers, which defines safe design and use strategies for equipment using A2L refrigerants. This standard limits the refrigerant concentration in a space in the event of a refrigerant leak. To meet the requirements, the UL standard defines minimum room area, refrigerant charge limit, minimum circulation airflow and/or ventilation airflow requirements, and limits the use of ignition sources in spaces. The standard may require a unit refrigerant leak detection system.

For equipment with R-454B and charge amounts less than or equal to 3.91 lbs per circuit, this UL standard does not prescribe a room area limit and does not require a refrigerant leak detection system or any circulation airflow or ventilation airflow mitigation strategies. However, ignition sources in ductwork must be evaluated.

Depending on the application, a specific requirement of ANSI/ASHRAE Standard 15, Safety Standard for Refrigeration Systems, could be more stringent than UL 60335-2-40 requirements. See *Refrigeration Systems and Machinery Rooms Application Considerations for Compliance with ASHRAE® Standard 15-2022 Application Engineering Manual (APP-APM001*-EN)* for more information.

Ignition Sources in Ductwork

Do not install open flames in the ductwork. Hot surfaces exceeding 700°C (1290°F) should not be installed in the ductwork unless the average airflow velocity is not less than 1.0 m/s (200 ft/min) across the heater and proof of airflow is verified before system is energized.

Electric heaters can exceed the surface temperature limit if airflow distribution is poor, or insufficient airflow is provided over the heater.

Surface temperatures of most gas heaters do not exceed the surface temperature limits due to ANSI construction requirements.

Ignition Sources in Unit

This UL-listed unit does not contain any ignition sources. All potential ignition sources, (including factory or field installed accessory electric heaters, gas heaters, relays, and contactors) were evaluated during product UL listing.

Minimum Room Area Limits (Refrigerant charge greater than 3.91 lb per circuit)

Equipment with R-454B charge amounts greater than 3.91 lb per circuit may require additional circulation or ventilation airflow mitigation strategies. In this case, there are two minimum room area (A_{min}) thresholds.

- The first threshold defines when equipment serving a single room is required to provide circulation airflow, either continuous or activated by a leak detection system. A ducted system requires circulation airflow unless the smallest room it serves is larger than the adjusted A_{min} threshold. This product contains a leak detection system if a circuit charge is greater than 3.91 lbs. As a result, no further leak detection system evaluation is needed.

- The second threshold defines when additional ventilation airflow is required. If the room area, A or TA , is below the adjusted A_{min} or TA_{min} threshold, additional ventilation is required to remove refrigerant in the event of a leak. Refer to UL 60335-2-40 Clause GG.8 and ANSI/ASHRAE Standard 15 Section 7 for natural and mechanical ventilation requirements. See equipment nameplate and table below for minimum room area.

Split systems minimum room area requirements need to be determined after final field charging. Use the following figures and the largest final circuit charge to determine the systems A_{min} value. Record the final charge value on the label provided on the condensing unit.

Figure 1. Charge vs min room area (IP)

Charge vs Min Room Area (IP)

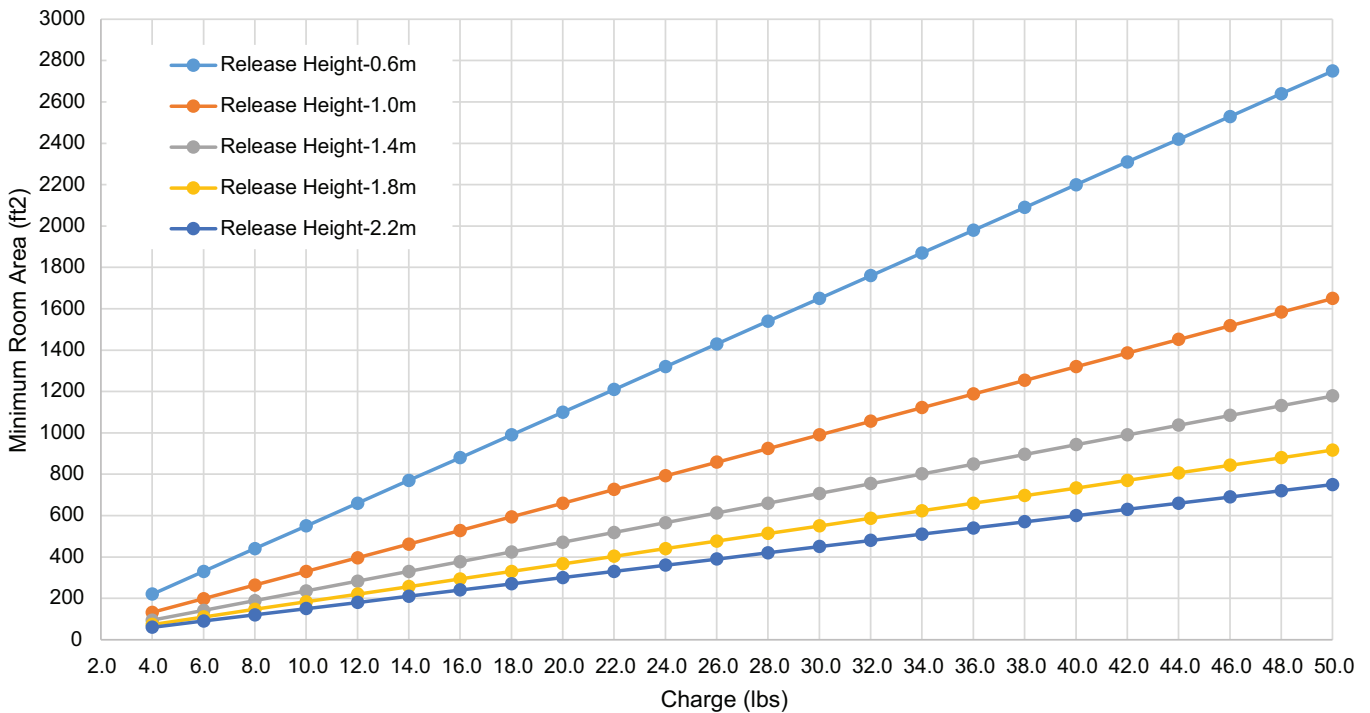
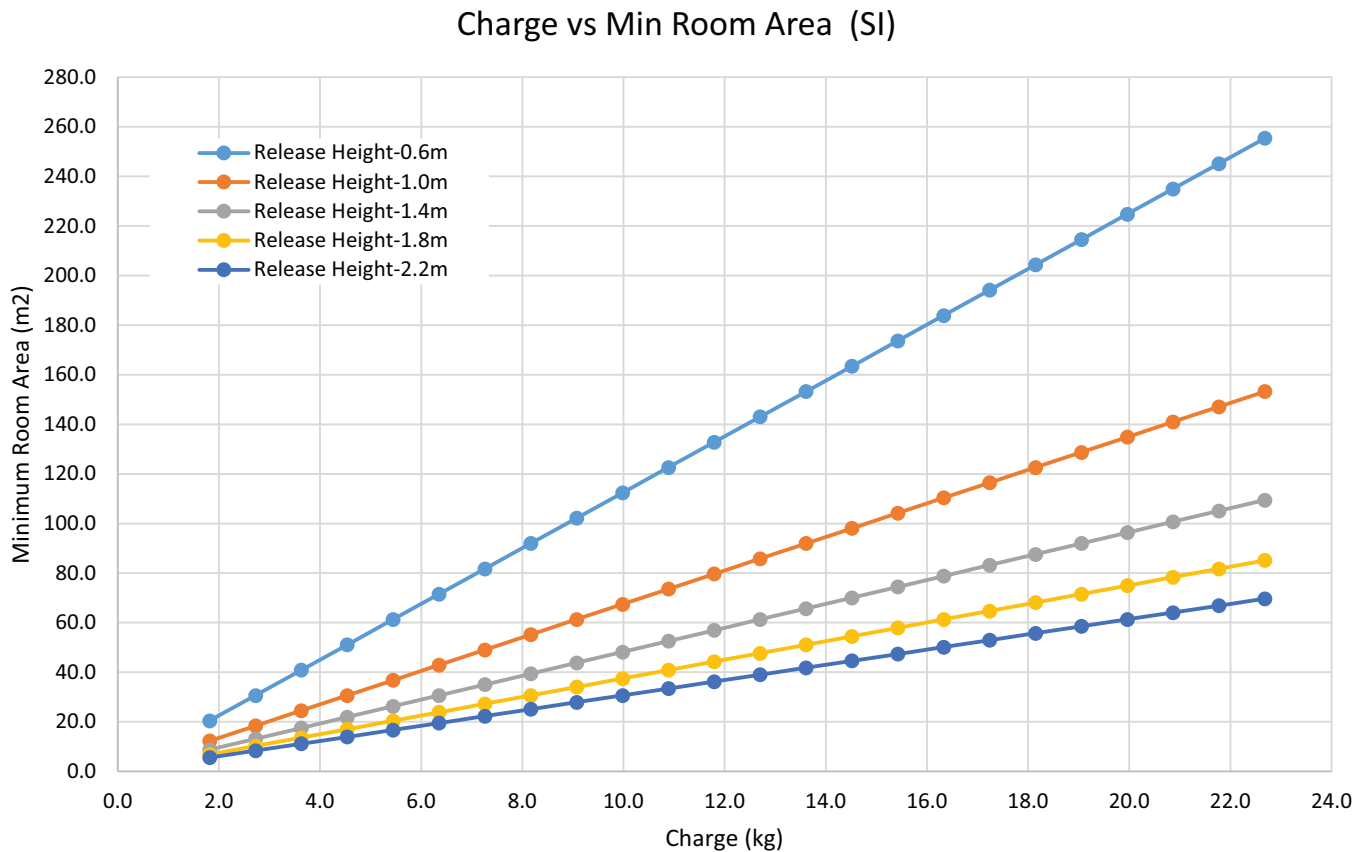

Figure 2. Charge vs min room area (SI)



Release height is the vertical distance from the floor to the lowest point in a space refrigerant would leak from first. The minimum value is 0.6 m from the floor. This point is typically the bottom of free return openings or supply diffusers. For fully ducted units, the release height is 2.2 meters.

$$A_{min.adj} = \text{Nameplate } A_{min} \times \text{Altitude Adj} \times \text{Height Adj} \times F_{occ}$$

Multiply the altitude adjustment factor in the table below by A_{min} listed on the unit nameplate or in the Installation, Operation, and Maintenance (IOM) manual.

Minimum Room Area (A_{min}) Adjustments

Use equation below to adjust the minimum room area, as applicable, based on the unit's installation height, altitude, and occupancy level it serves.

Table 1. Altitude adjustment factor

Altitude (ft)	Sea Level to 2000	2001 to 4000	4001 to 6000	6001 to 8000	8001 to 10000	10001 to 12000	12001 to 14000	14001 to 15000	Over 15000
A_{min} Adjustment	1	1.05	1.11	1.17	1.24	1.32	1.41	1.51	1.57

In addition, A_{min} can be adjusted if the unit is installed in a room at a height that is higher than the minimum height shown on the unit. To adjust A_{min} , multiply by the ratio of the unit minimum release height (in meters) / actual release height (in meters). Use 0.6 m in the ratio for unit minimum installation heights less than or equal to 0.6 m.

For institutional occupancies, ASHRAE Standard 15 applies an additional adjustment factor F_{occ} to the amount of a charge allowed in a space. To calculate the adjusted

A_{min} for institutional occupancies, multiply the A_{min} on the nameplate by two.

EXAMPLE 1: 20 Ton Packaged Rooftop Multi-Zone VAV System Serving an Institutional Occupancy Space

The packaged unit serves 7600 ft² of a nursing home located at an altitude of 4000 ft. The unit has two equally charged 10 ton refrigeration circuits. Each circuit has 12 lbs

of refrigerant with a minimum room area requirement of 180 ft² with a 2.2 m release height.

$$TA_{\text{min.adj}} = 180 \text{ ft}^2 \times 1.05 \times 2 = 378 \text{ ft}^2$$

No additional ventilation is required.

EXAMPLE 2: 10 Ton Split System Serving a Single Commercial Occupancy Space

The split system serves a 1500 ft² manufacturing space at 5000 ft altitude. The final installed charge of the single circuit 10 ton unit is 20 lb. The unit has an open return with a release height of 1 m and ducted supply air. The unit A_{min} is 660 ft².

$$A_{\text{min.adj}} = 660 \text{ ft}^2 \times 1.11 = 733 \text{ ft}^2$$

No additional ventilation is required.

Determining Room Area (A or TA)

The room area (A) is the room area enclosed by the projection to the floor of the walls, partitions, and doors of the space that the equipment serves. For ducted systems, total room area (TA) of all rooms connected by ducts, may be used instead of A.

Rooms connected by drop ceilings only are not considered a single room.

Rooms on the same floor of the building, and connected by an open passageway, can be considered part of the same room if the passageway is a permanent opening, extends to the floor and is intended for people to walk through.

Adjacent rooms on the same floor of the building and connected by permanent openings in the walls and/or doors between rooms (including gaps between the wall and the floor), can be considered part of the same room if the openings meet the following criteria.

- The opening is permanent and cannot be closed.
- Openings extending to the floor, such as door gaps, need to be at least 20 mm above the floor covering surface.
- Natural ventilations opening areas must meet the requirements of ANSI/ASHRAE Standard 15-2022, Section 7.2.3.2.

Rooms that are connected by a mechanical ventilation system can be considered a single room area if the

mechanical ventilation system meets the requirements of ANSI/ASHRAE Standard 15-2022, Section 7.6.4.

Leak Detection System (Refrigerant charge greater than 3.91 lb per circuit)

The leak detection system consists of one or more refrigerant detection sensors. When the system detects a leak, the following mitigation actions will be initiated until refrigerant has not been detected for at least 5 minutes:

- Energize the supply fan(s) to deliver a required minimum amount of circulation airflow.
- Disable compressor operation.
- Provide an output signal to fully open all zoning dampers, such as VAV boxes.
- Provide an output to energize additional mechanical ventilation (if needed).
- Units without airflow proving will disable electric heat sources.

Building fire and smoke systems may override this function.

If the refrigerant sensor has a fault, is at the end of its life, or is disconnected, the unit will initiate the mitigation actions. Mitigation actions may be verified by disconnecting the sensor.

The refrigerant sensors do not need service. Use only manufacturer-approved sensors when replacement is required.

Field Piping Installation and Charging

When refrigerant piping is routed indoors, protect from physical damage in operation or service, and verify installation complies with national and local codes. All joints must be accessible for inspection prior to being covered.

Follow the Refrigerant Charging procedure. Prior to refrigerant charging, check field-made indoor joints for leaks using an instrument with a sensitivity of 5 grams per year refrigerant. Pressurize the system to 25% of the maximum allowable pressure. Verify no leaks are detected.

Pre-Installation

Unit Inspection

Inspect material carefully for any shipping damage. If damaged, it must be reported to, and claims made against the transportation company. Compare the information that appears on the unit nameplate with ordering and submittal data to ensure the proper unit was shipped. Available power supply must be compatible with electrical characteristics specified on component nameplates. Replace damaged parts with authorized parts only.

Important: Units ordered with a VFD cannot be field converted to 460 V from 208-230 or from 208-230 V to 460 V.

Inspection Checklist

To protect against loss due to damage incurred in transit, complete the following checklist upon receipt of the unit.

- Inspect individual pieces of the shipment before accepting the unit. Check for obvious damage to the unit or packing material.
- Inspect the unit for concealed damage before it is stored and as soon as possible after delivery. Concealed damage must be reported within 15 days. If concealed damage is discovered, stop unpacking the shipment. Do not remove damaged material from the receiving location. Take photos of the damage if possible. The owner must provide reasonable evidence that the damage did not occur after delivery.
- Notify the carrier's terminal of damage immediately by phone and by mail. Request an immediate joint inspection of the damage by the carrier and the consignee.
- Notify the sales representative and arrange for repair. Do not repair the unit until the damage is inspected by the carrier's representative.

Lifting Recommendations

⚠ WARNING

Improper Unit Lift!

Failure to properly lift unit in a LEVEL position could result in unit dropping and possibly crushing operator/technician which could result in death or serious injury, and equipment or property-only damage.

Test lift unit approximately 24 inches (61 cm) to verify proper center of gravity lift point. To avoid dropping of unit, reposition lifting point if unit is not level.

NOTICE

Equipment Damage!

Use spreader bars to prevent straps from damaging the unit. Install the bars between lifting straps, both underneath the unit and above the unit to prevent the straps from crushing the unit cabinet or damaging the finish.

Before preparing the unit for lifting, estimate the approximate center of gravity for lifting safety. Because of placement of internal components, the unit weight may be unevenly distributed. See “,” for approximate unit weights.

The crated unit can be moved using a forklift of suitable capacity. For lifting the unit, attach lifting straps or slings securely to the lifting holes at each corner (see unit drawings in “,”). Use spreader bars to protect the unit casing from damage. Test lift the unit to determine proper balance and stability.

Clearances

Provide enough space around the unit to allow unrestricted access to all service points. Refer to the “Dimensional Data,” p. 15 for unit dimensions and minimum required service and free air clearances. Observe the following points to ensure proper unit operation.

1. Do not install the unit under a low overhang. Condenser discharge must not be restricted—refer to notes in “Dimensional Data,” p. 15.
Note: Do not obstruct condenser discharge air. This can result in warm air recirculation through the coil.
2. Do not locate the unit in a position where runoff water, or falling snow from roof, can fall into the fan discharge openings.
3. Condenser intake air is supplied from three or four sides of the unit. Adhere to the minimum required clearances given in unit dimensional drawings (see “Dimensional Data,” p. 15).

Unit Mounting

⚠ WARNING

Risk of Roof Collapsing!

Failure to ensure proper structural roof support could cause the roof to collapse, which could result in death or serious injury and property damage.

Confirm with a structural engineer that the roof structure is strong enough to support the combined weight of the roofcurb, the unit, and any accessories.

Structural Preparation

NOTICE

Roof Damage!

System contains oil and refrigerant under high pressure. Roofs should be protected from exposure to oils and refrigerant in the system. If rooftop is not protected, damage to the roof may occur.

Important: Refer to local building codes for proper installation. All installation must comply with local building codes.

Rooftop Mounting

If the unit will be roof mounted, determine for certain that the structure is strong enough to support the unit and any required accessories, see “,”. The unit should be elevated on a level, field fabricated four-inch steel or wood 4-inch x 4-inch mounting frame. Complete the frame and secure it into position before lifting the unit to the roof. The mounting frame must support a minimum of three of the unit’s four sides and should span roof supports to distribute the load on the roof.

Figure 3. Roof mounted unit

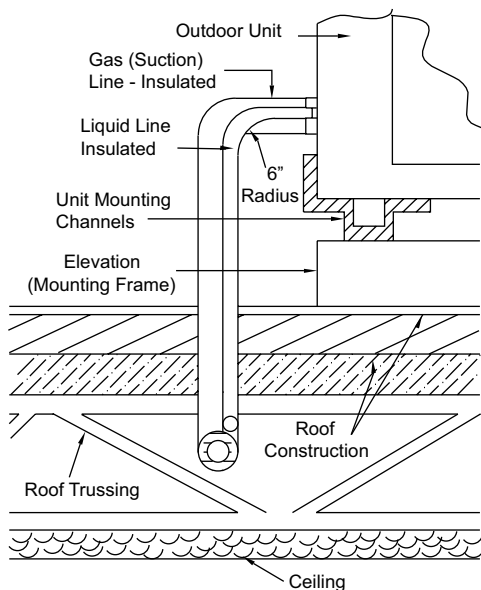

Ground Level Mounting

For ground level installation, the unit base should be adequately supported and hold the unit near level. The installation must meet the guidelines set forth in local codes. The support should extend two inches beyond the unit base channels at all points. The unit and support must be isolated from any adjacent structure to prevent possible noise or vibration problems. Any ground level location must comply with required clearances given in the unit dimensional drawings (see “Dimensional Data,” p. 15).

Snow Belt Recommendations

In regions where deep snow is encountered, raise the unit a minimum distance of 8 to 12 inches above the mounting surface. This will reduce the risk of snow blocking the coil and improves runoff of water produced during the defrost cycle. Avoid locating the unit where snow tends to drift. Snow accumulations must be removed from around the unit immediately to prevent drastic efficiency reduction. A snow drift barrier may be constructed around the unit to prevent snow blockage. Clearance between the snow barrier and the unit must comply with the clearances given in “Dimensional Data,” p. 15.

Installation Checklist

Complete this checklist once the unit is installed to verify that all recommended procedures have been accomplished before starting the system. Do not operate the system until all items covered by this checklist are complete.

- Inspect unit location for proper required service clearances.
- Inspect unit location for proper free air clearances.
- Inspect unit location for secure, level mounting position.
- Remove coil protection boards on microchannel units.
- Verify condenser fans turn freely without rubbing and are properly tightened on the shafts.

Refrigerant Piping

- Properly sized/constructed liquid and suction lines connected to stubs at both the indoor and outdoor units?
- Insulated the entire suction line?
- Insulated portions of liquid line exposed to extremes in temperature?
- Performed initial leak test?
- Evacuated each refrigerant circuit to 500 microns?
- Charged each circuit with proper amount of R-454B?

Electrical Wiring

- Provided unit power wiring (with disconnect) to proper terminals in the unit control enclosure?
- Installed system indoor thermostat or zone sensor?
- Installed system low voltage interconnecting wiring to proper terminals of outdoor unit, indoor unit and system thermostat or zone sensor?
- Checked all electrical connections to verify all are properly tightened and connected?
- Verified operation of crankcase heaters?

Dimensional Data

Heat Pump

Figure 4. Height, width and depth measurements

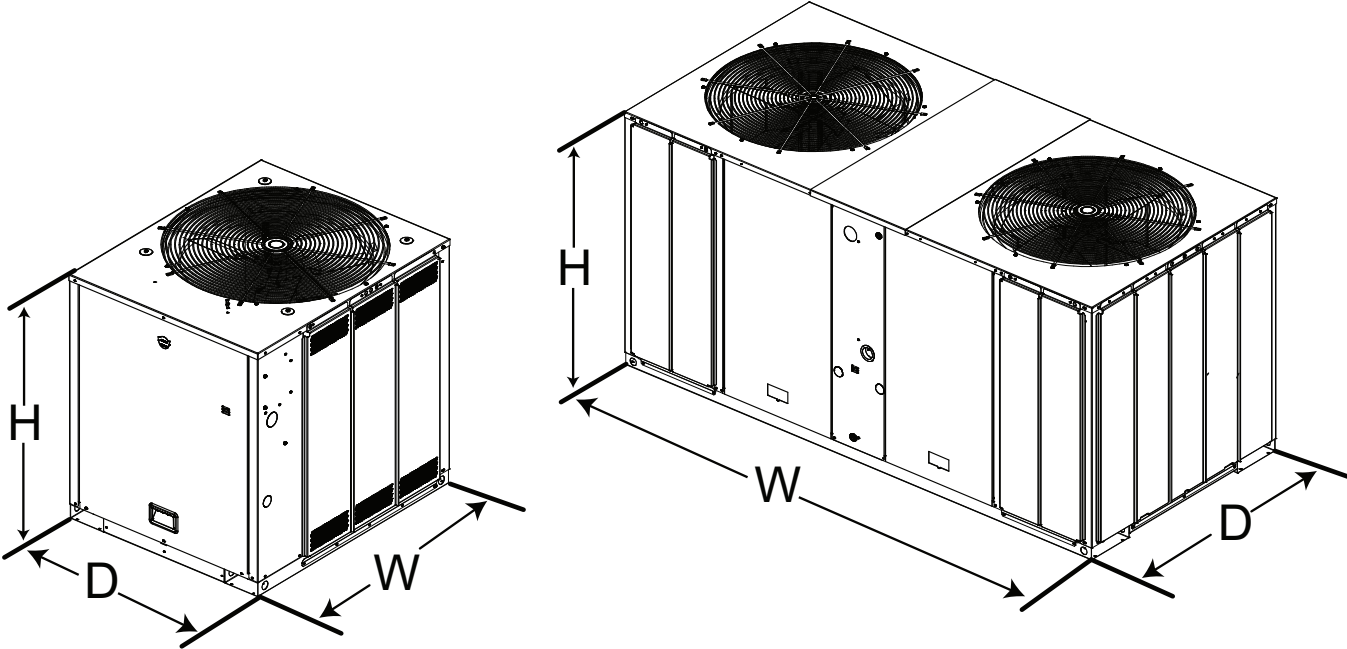

	H - in. (mm)	W - in. (mm)	D - in. (mm)
TWA072K*A, 090K*A	39.2 (996)	42.1 (1070)	36.3 (922)
TWA072K*D, 090K*D	39.2 (996)	51.9 (1317)	39.3 (999)
TWA120	45.2 (1150)	51.9 (1317)	39.3 (999)
TWA180, 240	45.2 (1150)	94.8 (2407)	45.4 (1152)

Dimensional Data

Figure 5. 6 and 7.5 ton heat pump, single compressor – in (mm)

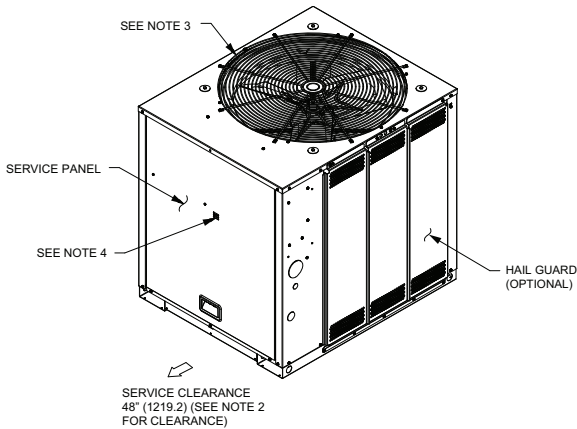

NOTES:

1. ACCESS OPENING IS FOR FIELD INSTALLED BAYLOAM ACCESSORY.
2. MINIMUM CLEARANCE FOR PROPER OPERATION IS 36" (914.4) FROM WALLS, SHRUBBERY, PRIVACY FENCES ETC. MINIMUM CLEARANCE BETWEEN ADJACENT UNITS IS 72" (1828.8). RECOMMENDED SERVICE CLEARANCE 48" (1219.2)
3. TOP DISCHARGE AREA SHOULD BE UNRESTRICTED FOR 100" (2540) MINIMUM. UNIT SHOULD BE PLACED SO ROOF RUN-OFF WATER OR FALLING SNOW FROM ROOF DOES NOT POUR/FALL DIRECTLY ON UNIT
4. OUTDOOR AIR TEMPERATURE SENSOR OPENING (DO NOT BLOCK OPENING)

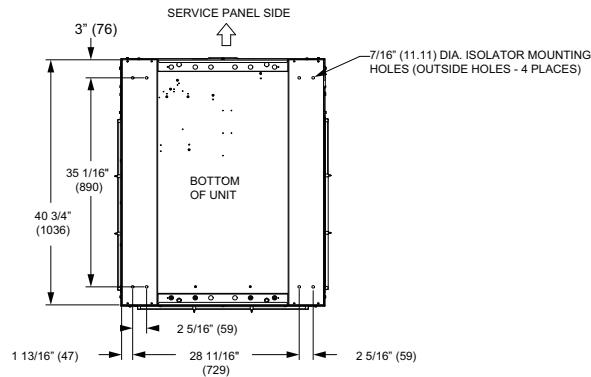
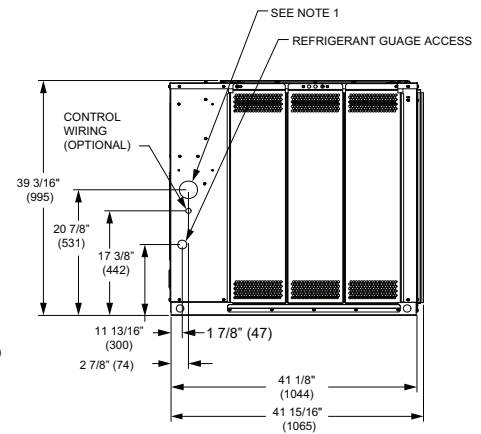
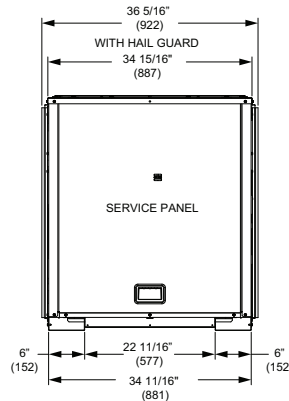
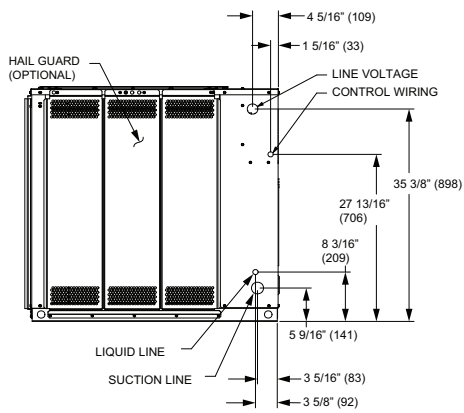
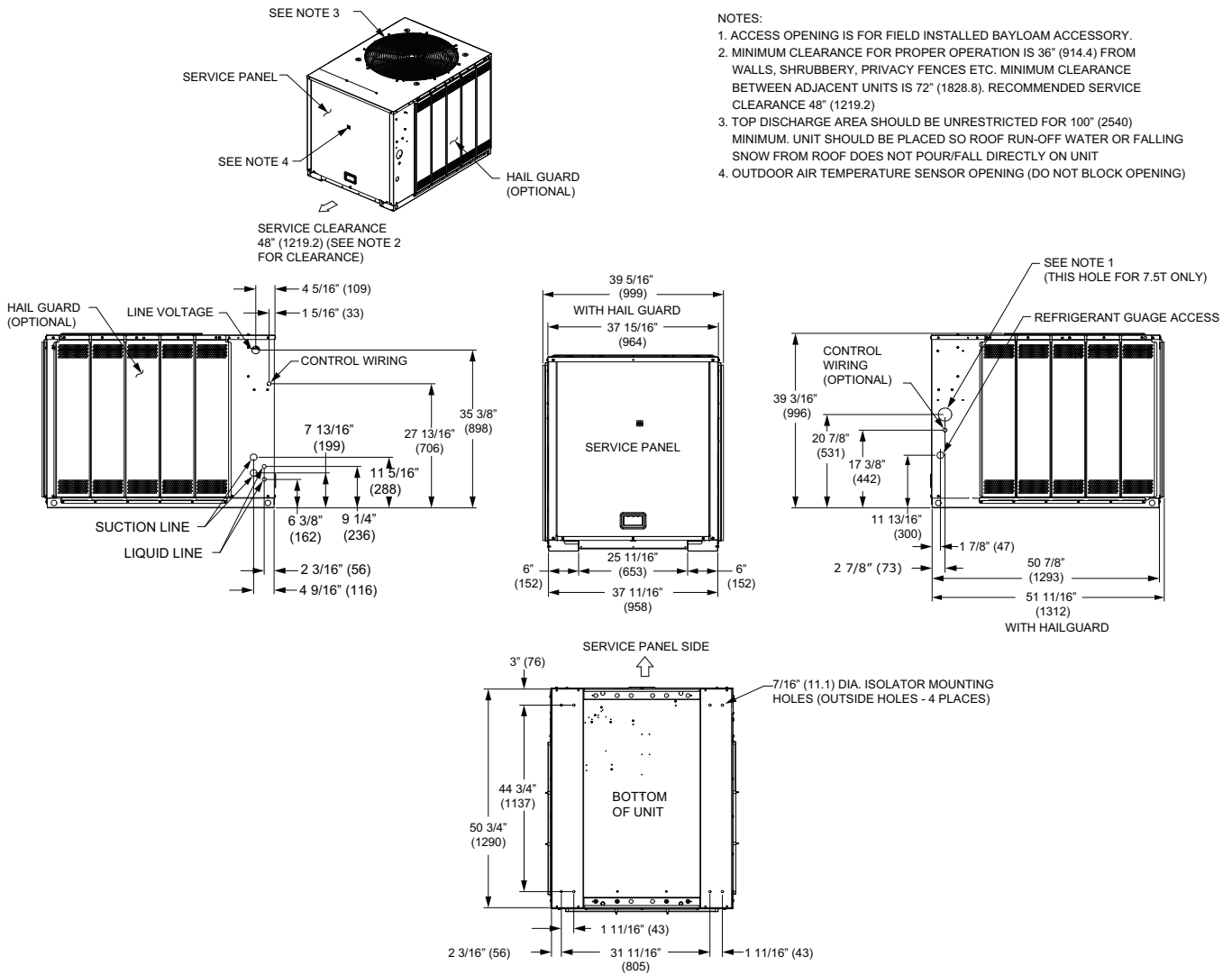

Figure 6. 6 and 7.5 ton heat pump, dual compressor – in (mm)



Dimensional Data

Figure 7. 10 ton heat pump, single compressor – in (mm)

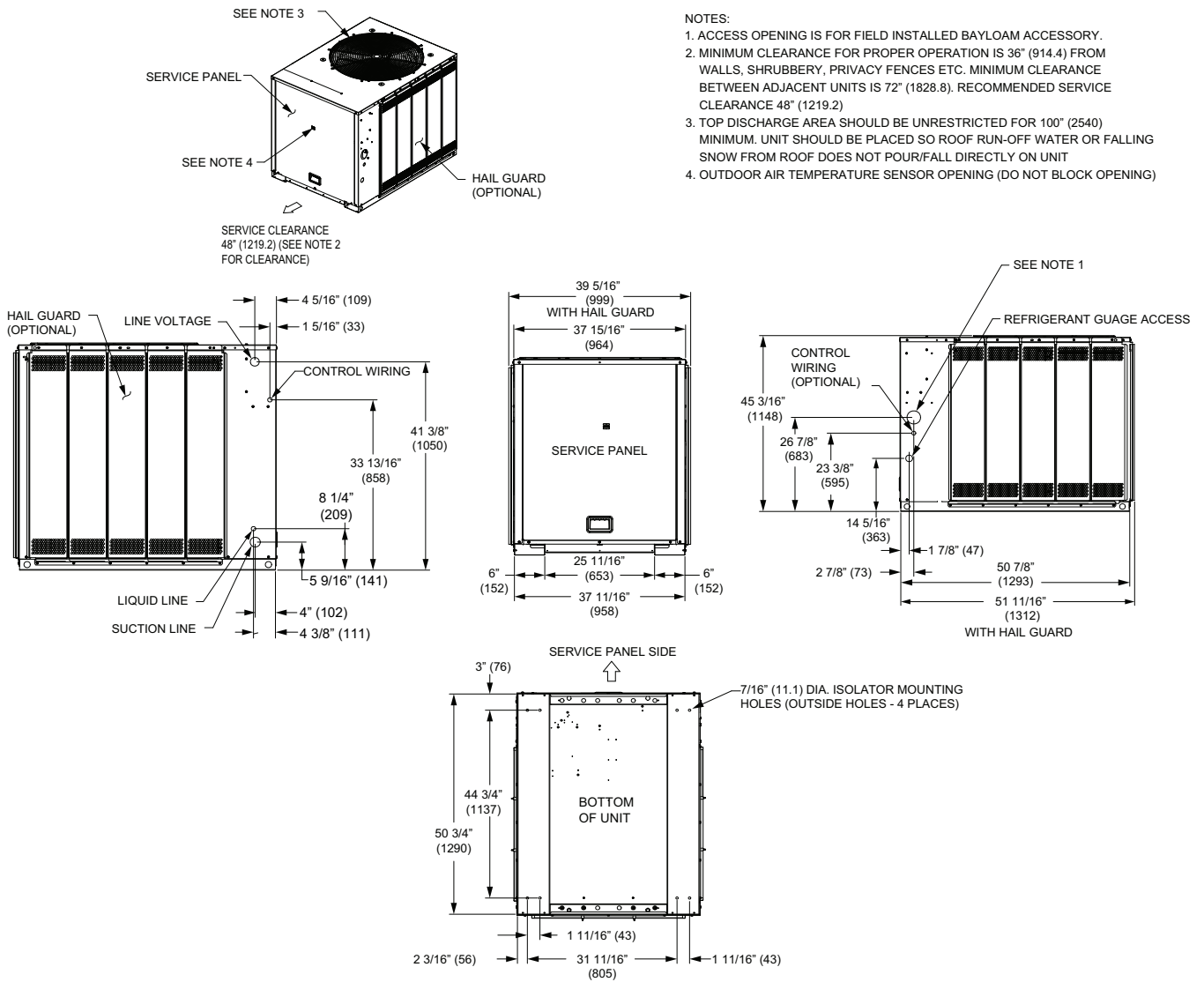
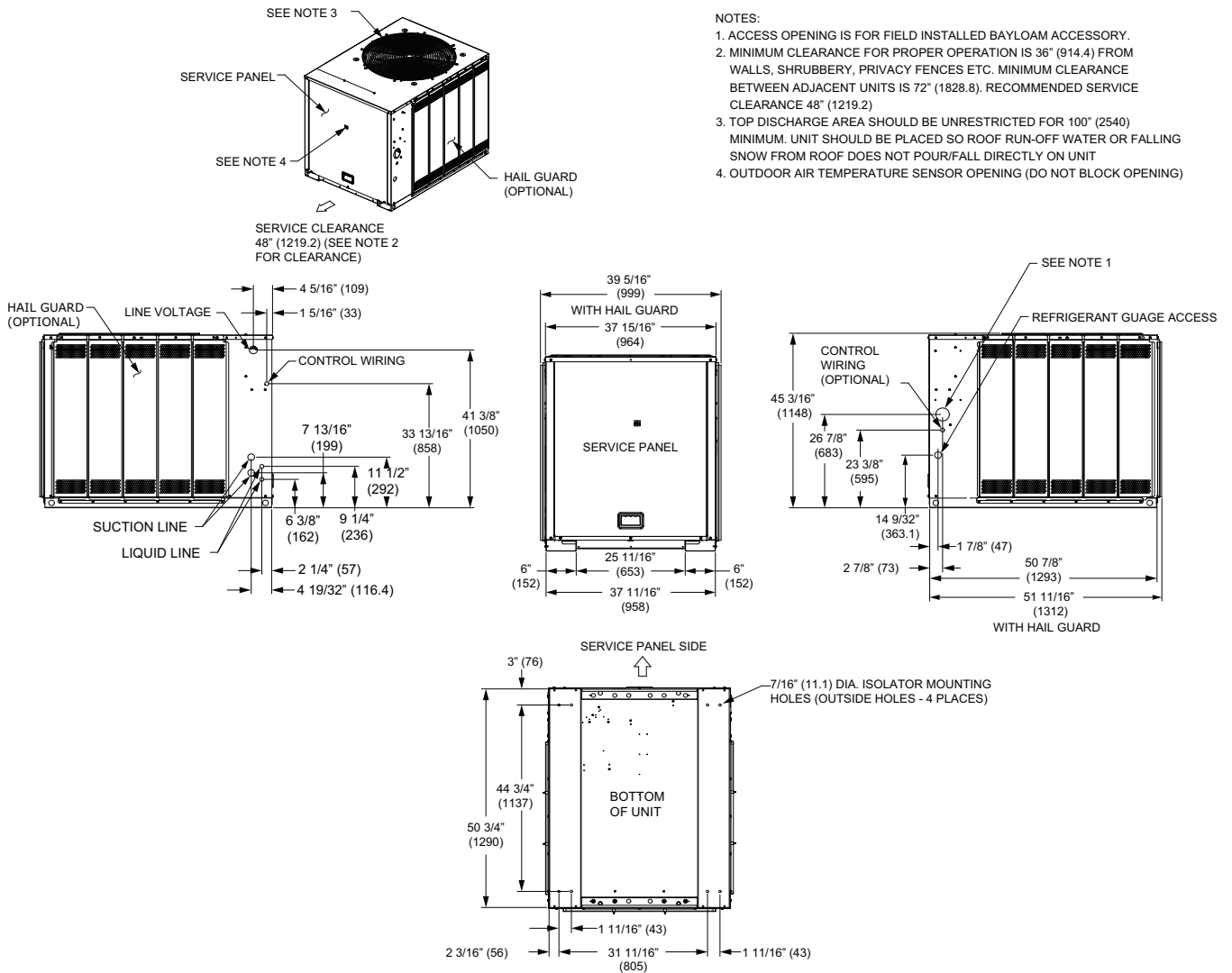
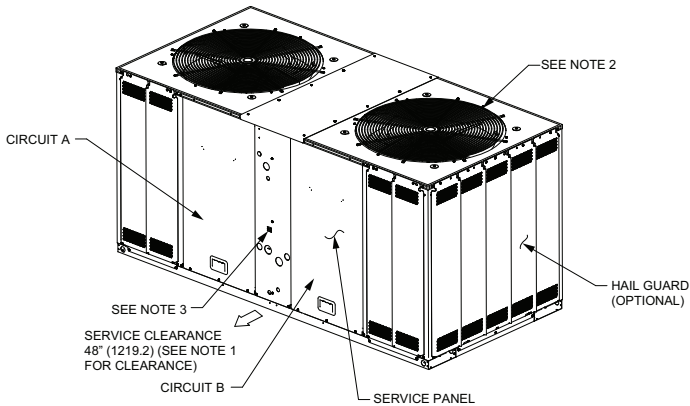

Figure 8. 10 ton heat pump, dual compressor – in (mm)



Dimensional Data

Figure 9. 15 and 20 ton heat pump, dual compressor – in (mm)



NOTES:

1. MINIMUM CLEARANCE FOR PROPER OPERATION IS 36" (914.4) FROM WALLS, SHRUBBERY, PRIVACY FENCES ETC. MINIMUM CLEARANCE BETWEEN ADJACENT UNITS IS 72" (1828.8). RECOMMENDED SERVICE CLEARANCE 48" (1219.2)
2. TOP DISCHARGE AREA SHOULD BE UNRESTRICTED FOR 100' (2540) MINIMUM. UNIT SHOULD BE PLACED SO ROOF RUN-OFF WATER OR FALLING SNOW FROM ROOF DOES NOT POUR/FALL DIRECTLY ON UNIT
3. OUTDOOR AIR TEMPERATURE SENSOR OPENING (DO NOT BLOCK OPENING)

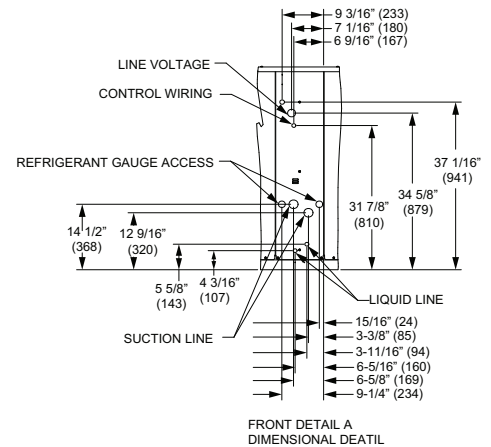
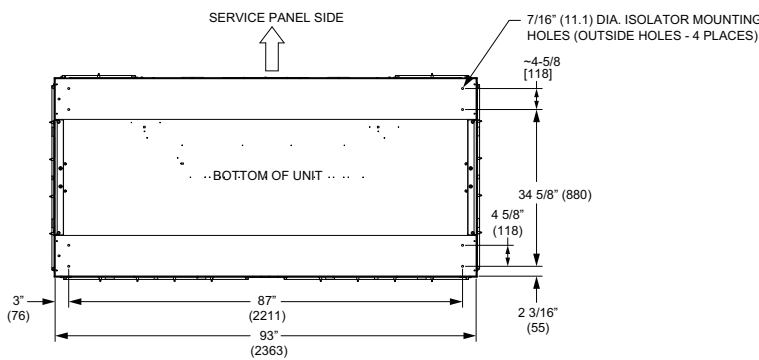
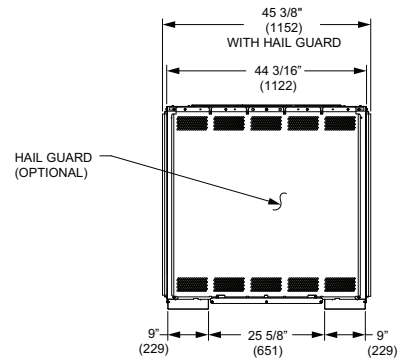
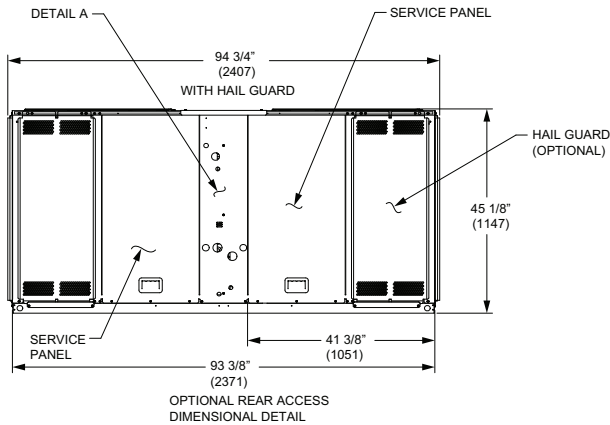

Weights

Heat Pump Condenser

Table 2. TWA R-454B unit and corner weights — lbs (60 Hz)

Tons	Model No.	Shipping Max (lbs)	Net Max (lbs)	Corner Weights			
				1	2	3	4
6	TWA072K*A	360	325	112	83	56	76
	TWA072K*D	434	395	138	94	100	65
7.5	TWA090K*A	395	363	90	128	66	80
	TWA090K*D	484	445	156	105	113	73
10	TWA120K*A	495	440	156	103	110	72
	TWA120K*D	487	448	157	106	113	74
15	TWA180K*D	874	782	242	172	202	169
20	TWA240K*D	1004	914	274	287	160	196

Figure 10. TWA072, 090, 120

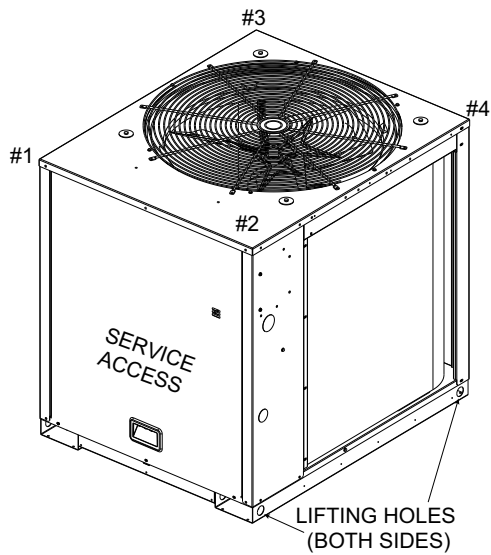
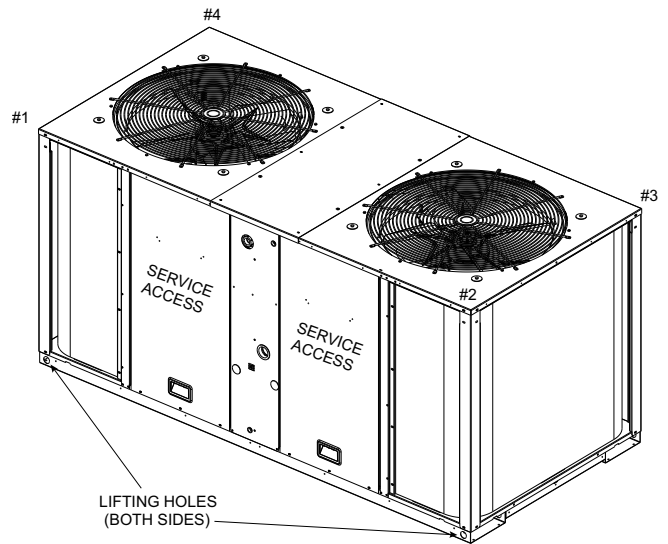

Figure 11. TWA180, 240



Installation

Refrigerant Piping Guidelines

Figure 12. Allowable elevation difference: TWA above indoor unit

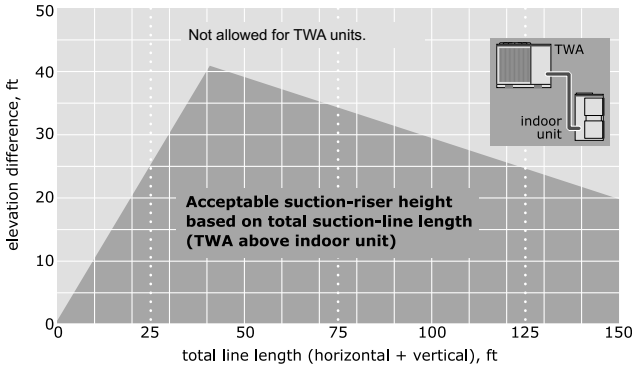
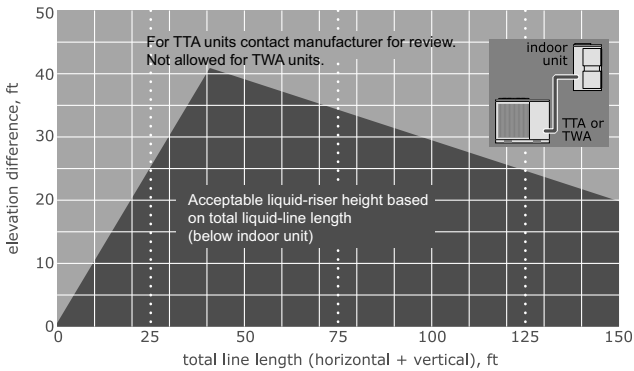

Figure 13. Allowable elevation difference: TTA or TWA below indoor unit



Note: Route refrigerant piping for minimum linear length, minimum number of bends and fittings.

Important: Read *Split System Air Conditioners Odyssey Application Guide SS-APG017*-EN* thoroughly before installing this unit.

Refrigerant Piping Procedures (Outdoor Units)

⚠ WARNING

R-454B Flammable A2L Refrigerant!

Failure to use proper equipment or components as described below could result in equipment failure, and possibly fire, which could result in death, serious injury, or equipment damage.

The equipment described in this manual uses R-454B refrigerant which is flammable (A2L). Use ONLY R-454B rated service equipment and components. For specific handling concerns with R-454B, contact your local representative.

⚠ WARNING

Refrigerant under High Pressure!

Failure to follow instructions below could result in an explosion which could result in death or serious injury or equipment damage.

System contains refrigerant under high pressure. Recover refrigerant to relieve pressure before opening the system. See unit nameplate for refrigerant type. Do not use non-approved refrigerants, refrigerant substitutes, or refrigerant additives.

Each unit ships with a holding charge of dry nitrogen. The nitrogen should be removed and the entire system evacuated (at the proper time) to avoid possible contamination.

1. Remove the compressor service access panel.
2. Locate the liquid and suction line access valves. Check that the piping connection stubs (Figure 14, p. 22) line up properly with the holes in the unit cabinet.

Figure 14. Outdoor units - refrigerant piping (with dry nitrogen)

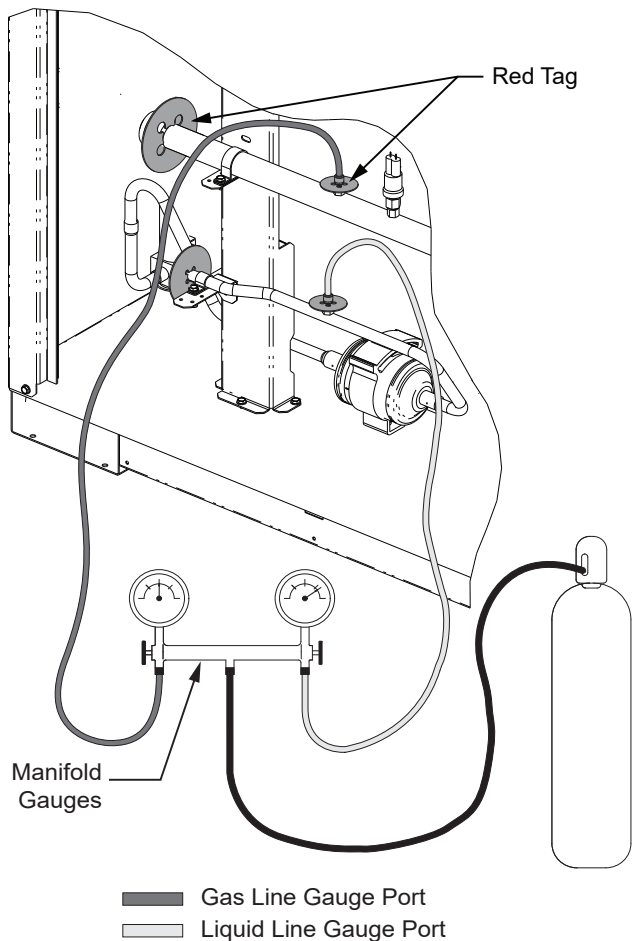

3. Install gauges to determine if the circuits are still pressurized. If not, the charge has escaped and should be repaired as required to obtain a leak-free circuit. If the circuits are still pressurized, use the gauges to slowly release the nitrogen charge to the atmosphere and remove both seal caps from the outdoor unit connection stubs.

NOTICE

System Component Damage!

Do not remove the seal caps from refrigerant connections until prepared to braze refrigerant lines to the connections. Excessive exposure to atmosphere (> 5 min.) may allow moisture or dirt to contaminate the system, damaging valve seals and causing ice formation in system components.

⚠ WARNING

Explosion Hazard and Deadly Gases!

Failure to follow all proper safe refrigerant handling practices could result in death or serious injury. Never solder, braze or weld on refrigerant lines or any unit components that are above atmospheric pressure or where refrigerant may be present. Always remove refrigerant by following the guidelines established by the EPA Federal Clean Air Act or other state or local codes as appropriate. After refrigerant removal, use dry nitrogen to bring system back to atmospheric pressure before opening system for repairs. Mixtures of refrigerants and air under pressure may become combustible in the presence of an ignition source leading to an explosion. Excessive heat from soldering, brazing or welding with refrigerant vapors present can form highly toxic gases and extremely corrosive acids.

4. Cut, fit and braze tubing, starting at the outdoor unit and work toward the indoor unit. See ["Charging Levels," p. 25.](#)
Note: Use long radius ells for all 90° bends.
All brazing should be done using a 2 to 3 psig dry nitrogen purge flowing through the pipe being brazed, see [Figure 14, p. 22.](#)

NOTICE

System Component Damage!

Install a regulating valve between the nitrogen source and the gauge manifold. Unregulated pressure can damage system components.

NOTICE

System Component Damage!

Wet-wrap all valves and protect painted surfaces from excessive heat. Heat can damage system components and the unit finish.

5. Shut off nitrogen supply. Shut off the manifold valve for the line that is connected to the suction line access valve. Disconnect the line from the access valve.
6. Reinstall the red tags, if they are removed during brazing.

Refrigerant Piping Procedures (Indoor Unit)

Once liquid and suction lines are complete to the refrigerant connections on the indoor unit, remove the gauge port core(s) on the indoor unit connection stubs to release the dry nitrogen charge.

NOTICE

Unit Damage!

Do not apply heat to remove seal caps until the gauge port cores have been removed. If seal caps are intact, application of heat may generate excessive pressure in the unit and result in damage to the coil or expansion valve.

1. Remove both seal caps from the indoor unit connection stubs.

NOTICE

Unit Damage!

Failure to follow instructions below could result in damaging the unit. Do not remove the seal caps from refrigerant connections until prepared to braze refrigerant lines to the connections. Due to the high hygroscopic properties of the POE oil, excessive exposure to atmosphere will allow moisture to contaminate the system, damaging the compressor.

2. Turn on nitrogen supply. Nitrogen enters through the liquid line gauge port.
3. Braze the liquid line connections.
4. Open the gauge port on the suction line and then braze the suction line to the connection stub. Nitrogen will bleed out the open gauge port on the suction line.
5. Shut off nitrogen supply.
6. Reinstall the red tags, if they are removed during brazing.

Leak Check

⚠ WARNING

Explosion Hazard!

Failure to follow these instructions could result in death or serious injury or equipment or property-only damage.

Use only dry nitrogen with a pressure regulator for pressurizing unit. Do not use acetylene, oxygen or compressed air or mixtures containing them for pressure testing. Do not use hydrogen mixtures containing refrigerant and air above atmospheric pressure for pressure testing as they may become flammable and could result in an explosion.

Refrigerant, when used as a trace gas should only be mixed with dry nitrogen for pressurizing units.

⚠ WARNING

Explosion Hazard!

Failure to follow safe leak test procedures below could result in death or serious injury or equipment or property-only-damage.

Never use an open flame to detect gas leaks. Use a leak test solution for leak testing.

After the brazing operation of refrigerant lines to both the outdoor and indoor unit is completed, the field brazed connections must be checked for leaks. Pressurize the system through the gauge port with dry nitrogen to 200 psi. Use soap bubbles or other leak-checking methods listed under A2L Work Procedures section to ensure that all field joints are leak free. If not, release pressure, repair and repeat leak test.

System Evacuation

1. After completion of leak check, evacuate the system.
2. Attach appropriate hoses from manifold gauge to gas and liquid line pressure taps.

Note: Unnecessary switching of hoses can be avoided and complete evacuation of all lines leading to sealed system can be accomplished with manifold center hose and connecting branch hose to a cylinder of R-454B and vacuum pump.

3. Attach center hose of manifold gauges to vacuum pump.

NOTICE

Operating Under Vacuum!

Failure to follow these instructions will result in compressor failure.

Do not operate or apply power to the compressor while under a vacuum.

4. Evacuate the system to hold a 500 micron vacuum.
5. Close off valve to vacuum pump and observe the micron gauge. If gauge pressure rises above 500 microns in one minute, then evacuation is incomplete or the system has a leak.
6. If vacuum gauge does not rise above 500 microns in 10 minutes, the evacuation should be complete.

NOTICE

Equipment Damage!

Charge with access port on the liquid line only.

Insulating and Isolating Refrigerant Lines

Insulate the entire suction line with refrigerant piping insulation. Also insulate any portion of the liquid line exposed to temperature extremes. Insulate and isolate liquid and suction lines from each other. Isolate refrigerant lines from the structure and any duct work.

Important:

1. To prevent possible noise or vibration problems, be certain to isolate refrigerant lines from the building.
2. All suction and hot gas bypass piping (if installed) should be insulated from the termination in the air handler to the condensing unit cabinet entry. Failure to do so can cause condensate drip off and performance degradation.
3. Prior to starting a unit, it is advisable to have the approved oils available in the event oil needs to be added to the system.
4. Refer to *Split System Air Conditioners Odyssey Application Guide SS-APG017*-EN* for units needing additional oil and for oil amounts.

NOTICE

Equipment Damage!
This is POE oil, which readily absorbs moisture. Always use new oil and never leave containers open to atmosphere while not in use.

Table 3. R-454B TWA approved oils

Unit Model Number	Approved Oils
TWA072K*A, TWA072K*D, TWA090K*A, TWA090K*D, TWA120K*A, TWA120K*D, TWA180K*D, TWA240K*D	Trane Oil Part Number OIL00094 (1 quart container)

For units equipped with compressors containing sight glasses, the oil level must be visible through the sight glass when the compressor is running under stabilized conditions and a few minutes after the compressor has stopped.

Refrigerant Charging Procedure

If charging by weight, refer to “Charging Levels,” p. 25 for starting change. If refrigerant adjustments are needed because of length of line, refer to the Charging Charts and Superheat values available on unit access panels.

Charge by weight through the gauge port on the liquid line. Follow the requirements listed under A2L Work Procedures section.

Notes:

- Refrigerant should only be charged in the liquid state.
- When possible, always charge the refrigerant into the liquid line of the unit.
- If the entire charge can't be charged into the liquid line, the balance of the unit charge can be metered through a charging manifold set as liquid — preferably through a schrader valve into the suction line to the compressor — only while the compressor is running.
- Check and adjust superheat using the superheat table, then re-check charging charts to determine if charge corrections are necessary. Refer to Charging Data for list of super heat tables available in e-Library.

NOTICE

Equipment Damage!
Never charge liquid refrigerant into the suction line of the unit with the compressor off.

Figure 15. Outdoor units - refrigerant piping

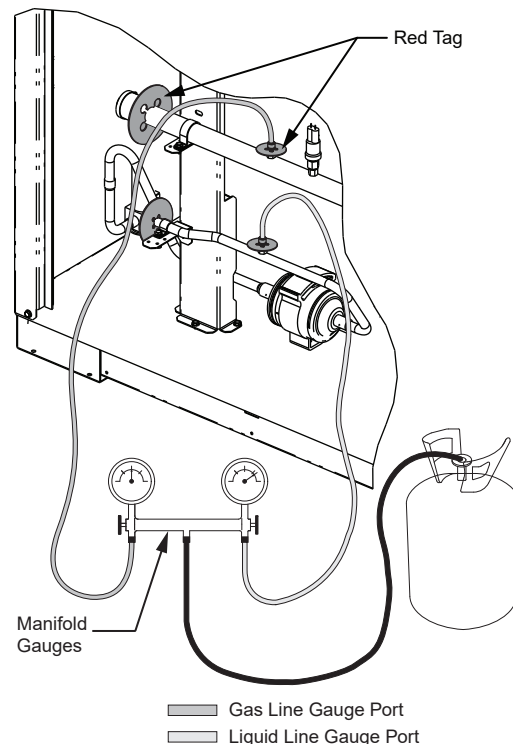

Charging Levels

Important: For the correct line diameter, for line lengths greater than 25 feet, see the *Split System Air Conditioners Odyssey Application Guide (SS-APG017*-EN)*.

Installation

Table 4. Estimated charge levels at ARI rated line lengths (25 feet)

Matched Set	Refrigerant Charge		Per Circuit	
	Circuit 1	Circuit 2	Liquid Line Diameter	Vapor Line Diameter
TWA072K*A w/ TWE090K*A	17.3	-	0.5 (1/2")	1.375 (1 3/8")
TWA072K*D w/ TWE072K*B	9.1	9.5	0.5 (1/2")	0.875 (7/8")
TWA090K*A w/ TWE090K*A	16.2		0.625 (5/8")	1.375 (1 3/8")
TWA090K*D w/ TWE090K*B	9.3	9.6	0.5 (1/2")	1.125 (1 1/8")
TWA120K*A w/ TWE120K*A	23.2	-	0.5 (1/2")	1.375 (1 3/8")
TWA120K*D w/ TWE120K*B	12.6	12.6	0.5 (1/2")	1.125 (1 1/8")
TWA180K*D w/ TWE180K*B	21.2	21.2	0.5 (1/2")	1.125 (1 1/8")
TWA240K*D w/ TWE240K*B	19.9	19.9	0.625 (5/8")	1.375 (1 3/8")

Notes:

1. For line lengths other than 25-inch, refer to the Split System Air Conditioners Odyssey Application Guide (SS-APG017*-EN) for charge levels, oil addition and line sizes.
2. For additional support with line lengths or refrigerant charge, refer to the Application Guide or contact Product Support.
3. TWA180K*D need a reducer for vapor line (1.375 to 1.125 inch) (1 3/8-inch to 1 1/8-inch), and a reducer for liquid line (0.625 to 0.5 inch) (5/8-inch to 1/2-inch).
4. TWA072K*D need a reducer for vapor line (1.125 to 0.875) (1 1/8-inch to 7/8-inch).

Liquid Charging

This procedure is accomplished with the unit operating. Electrical connections must be complete. Do not proceed until the system is ready to operate.

Note: *The compressor access panel must be installed when the unit is running and being charged. Manifold hoses must be routed through refrigerant gauge access hole(s). See “Dimensional Data,” p. 15 for specific locations.*

⚠ WARNING

Live Electrical Components!

Failure to follow all electrical safety precautions when exposed to live electrical components could result in death or serious injury.

When it is necessary to work with live electrical components, have a qualified licensed electrician or other individual who has been properly trained in handling live electrical components perform these tasks.

1. Turn on power to the unit. Allow the system to run for 15 minutes to stabilize operating conditions.
2. Measure airflow across the indoor coil. Compare the measurements with the fan performance data in the Data/Submittal. Once proper airflow is established, compare discharge pressure and liquid temperature to the charging charts. Add or remove refrigerant (liquid only) as required to obtain correct discharge pressure and liquid temperature.
3. Check suction line superheat and condenser sub-cooling to ensure the unit is operating properly.
4. Disconnect all power to the unit.

Important: *If the unit is charged and left without power until a later date, the crankcase heater should be energized for a minimum of 8 hours prior to powering the compressor(s).*

⚠ WARNING

Hazardous Voltage w/Capacitors!

Failure to disconnect power and discharge capacitors before servicing could result in death or serious injury.

Disconnect all electric power, including remote disconnects and discharge all motor start/run capacitors before servicing. Follow proper lockout/tagout procedures to ensure the power cannot be inadvertently energized. For variable frequency drives or other energy storing components provided by Trane or others, refer to the appropriate manufacturer’s literature for allowable waiting periods for discharge of capacitors. Verify with a CAT III or IV voltmeter rated per NFPA 70E that all capacitors have discharged.

5. Remove the charging system from the unit.

6. Reinstall the red tags on the schrader valves, if they were removed while charging.
7. Replace all panels.

Electrical Wiring

⚠ WARNING

Proper Field Wiring and Grounding Required!

Failure to follow code could result in death or serious injury.

All field wiring **MUST** be performed by qualified personnel. Improperly installed and grounded field wiring poses **FIRE** and **ELECTROCUTION** hazards. To avoid these hazards, you **MUST** follow requirements for field wiring installation and grounding as described in NEC and your local/state/national electrical codes.

Field wiring consists of providing power supply to the unit, installing the system indoor thermostat or zone sensor and providing low voltage system interconnecting wiring. Access to electrical connection locations is shown in “Dimensional Data,” p. 15. Determine proper wire sizes and unit protective fusing requirements by referring to the unit nameplate. Field wiring diagrams for accessories are shipped with the accessory.

Unit Power Supply

The installer must provide line voltage circuit(s) to the unit main power terminals as shown by the unit wiring diagrams. Adhesive backed diagrams are affixed inside the control box cover panel. Wiring diagrams are also available through e-Library or by contacting a local sales office. Power supply must include a disconnect switch in a location convenient to the unit. Ground the unit according to local codes and provide flexible conduit if codes require and/or if vibration transmission may cause noise problems.

Important: *All wiring must comply with applicable local and national (NEC) codes. Type and location of disconnect switches must comply with all applicable codes.*

⚠ WARNING

Proper Field Wiring and Grounding Required!

Failure to follow code could result in death or serious injury.

All field wiring **MUST** be performed by qualified personnel. Improperly installed and grounded field wiring poses **FIRE** and **ELECTROCUTION** hazards. To avoid these hazards, you **MUST** follow requirements for field wiring installation and grounding as described in NEC and your local/state/national electrical codes.

NOTICE

Use Copper Conductors Only!

Failure to use copper conductors could result in equipment damage as the equipment was not designed or qualified to accept other types of conductors.

the Split System Air Conditioners Odyssey with Symbio™ Controls Wiring and Start-up (SS-SVN017*-EN).

Note: Refer to thermostat or zone sensor wire installation guide for proper wire gauge.

Low Voltage Wiring

Mount the indoor thermostat, zone sensor, or programmable zone sensor in accordance with the corresponding thermostat installation instructions. Install color-coded, weather-proof, multi-wire cable according to

Symbio™ Controls

Wiring shown with dashed lines is to be furnished and installed by the customer. All customer supplied wiring must be copper only and must conform to NEC and local electrical codes. Codes may require line of sight between disconnect switch and unit.

Figure 16. Symbio™ jobsite connections

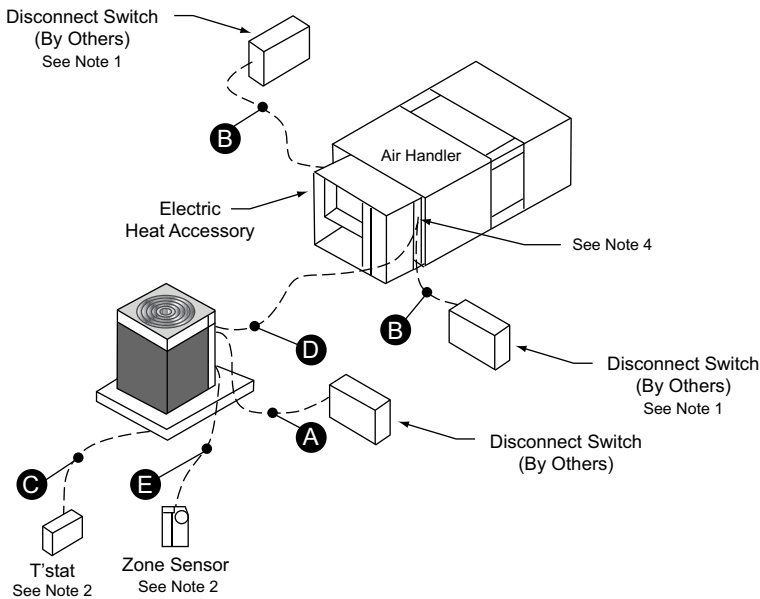

Power Wires

- A. 3 wires, line voltage for 3 phase, 1 grounding wire**
- B. 3 wires, line voltage for 3 phase, (2 wires for single phase) 1 grounding wire**

Control Wires

- C. Heat Pump thermostat: 6 to 9 wires depending on T'stat options and stages of cooling and heating
- D. Wiring between indoor and outdoor unit: 5 to 11 wires depending on unit control options*
- E. Zone Sensor: 4 to 7 wires depending on zone sensor model*

Communication signal wires require shielded twisted pairs.

Use Comlink cable with a PVC jacket, 18/1 PR, stranded shield, 25 PF/FT plenum rated for the field communication signal wiring. Refer to wiring diagram schematics for identification of shielded twisted pairs.

Notes:

1. When electric heater accessory is used, single point power entry or dual point power entry is field optional. Single point power entry option is through electric heater only.
2. *Choose only one of the following; Thermostat, Mechanical Zone Sensor, Programmable Zone Sensor Panel or BAS Zone Sensor.
3. **

⚠ WARNING

Electrical Shock Hazard!
 Failure to follow instructions below could result in death or serious injury.
 Properly connect the system's oversized protective earthing (grounding) terminal(s).

4. Once power wire connections are complete inside the air handler control box, seal the sheet metal entry points of the control box by using parts (neoprene gasket, grommet, and plug) shipped along with the air handler unit package.
5. For detailed controls wiring instructions, see Split System Air Conditioners Odyssey™ with Symbio™ Controls Wiring and Start-Up Installation Guide (SS-SVN016*-EN).

Important: For the EDC switch to be functional and thereby facilitate reliable unit operation, make the EDC connections from the indoor to the outdoor control boxes.

Refrigerant Circuit

Figure 17. Typical split system heat pump - cooling - refrigerant circuit

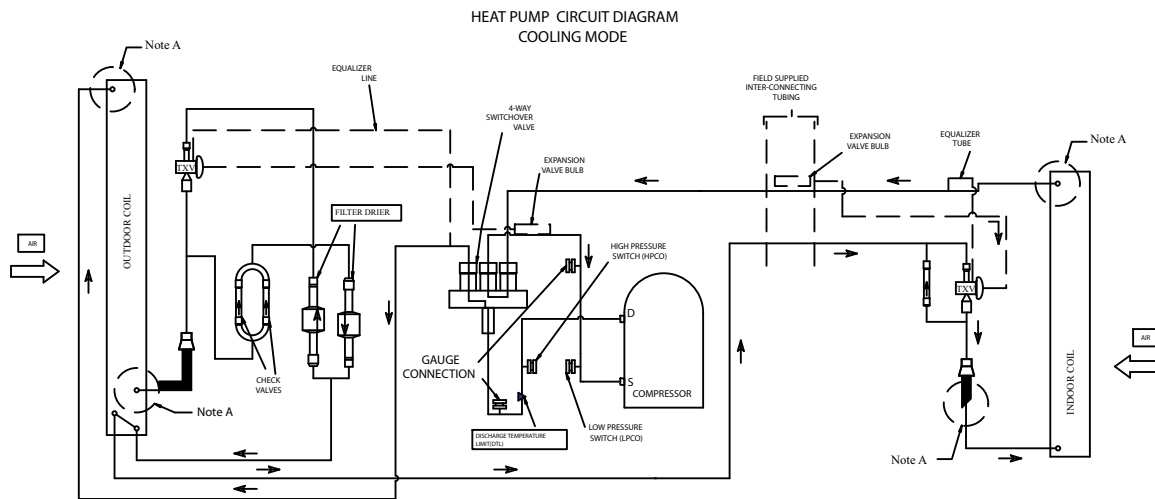

→
INDICATES DIRECTION OF REFRIGERANT FLOW

NOTE A: ONLY ONE OUTDOOR AND INDOOR COIL REFRIGERANT ENTRY AND EXIT CIRCUIT IS SHOWN. ALL MODELS HAVE MULTIPLE ENTRY AND EXIT CIRCUITS.

NOTE B: DUAL CIRCUIT MODELS HAVE 2 REFRIGERATION CIRCUITS.

Table 5. Recommended thermostat wire size

Wire Size (Gauge)	Maximum Wire Length Physical distance between Unit & T'stat
22	30 Feet
20	50 Feet
18	75 Feet
16	125 Feet
14	200 Feet

Table 6. Zone sensor module wiring

Distance from Unit to Control	Recommended Wire Size
0-150 feet (0-45.7 m)	22 gauge (0.33 mm ²)
151-240 feet (46-73.1 m)	20 gauge (0.50 mm ²)
241-305 feet (73.5-117.3 m)	18 gauge (0.75 mm ²)
386-610 feet (117.7-185.9 m)	16 gauge (1.31 mm ²)
611-970 feet (186.2-295.7 m)	14 gauge (2.08 mm ²)

Field Wiring

Refer to the latest version of Split System Air Conditioners Odyssey with Symbio Controls Wiring and Start-up (SS-SVN017*-EN) for instructions on field wiring connections.

000023130

Figure 18. Typical split system heat pump - heating - refrigerant circuit

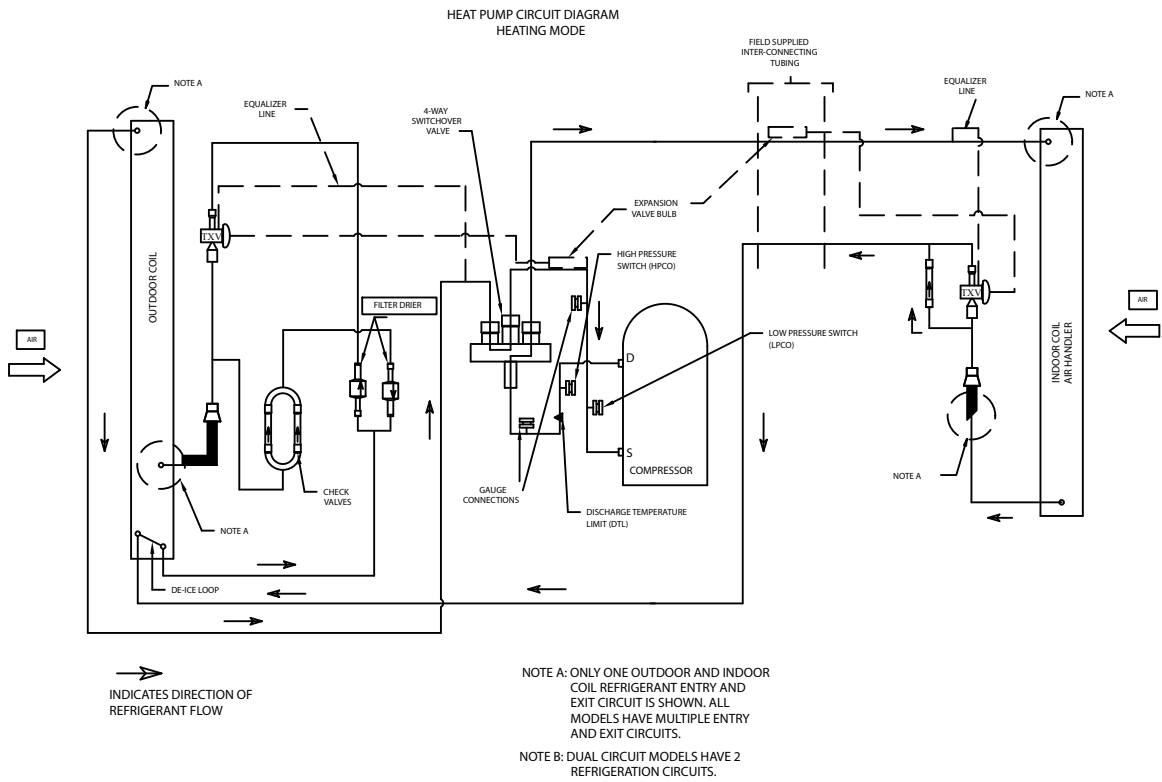

Pre-Start

Control Circuit Features

Note: Not all of these features may be required for your unit, check electrical schematic.

Discharge Temperature Limit (DTL)

The control's sensor is located on the discharge line. This device will shut off the compressor and the outdoor fan(s) if the discharge temperature exceeds the DTL setting. Once the discharge temperature has returned to normal, the compressor will cycle back on.

Low Outdoor Ambient Cooling

All Odyssey units with Symbio™ 700 controls have cooling capabilities down to 0°F as standard. At temperatures below 55°F for single compressor units and 40°F for dual compressor units, some reduction in cooling capacity can be expected. At this temperature, equipment can provide approximately 60% of the mechanical cooling capacity. When the optional Low Ambient Accessory kit is field installed, the full capacity of the unit is available down to 0° F.

Evaporator Defrost Control (EDC)

This control is located in the Air Handler. The control's sensing tube is embedded vertically in the evaporator coil, near the center. This device will stop the compressor if the indoor coil temperature drops below its setting. The indoor air will still circulate across the coil bringing the temperature of the coil back up to the cut-in temperature of the evaporator defrost control.

Low Pressure Cut-Out (LPC)

This control's sensor is located in the suction (gas) line, near the compressor. This control will stop the compressor and the outdoor fans if suction pressure drops below the Low Pressure Cut-Out setting. Once the suction pressure

has returned to normal, the compressor and outdoor fans will cycle back on.

High Pressure Cut-Out (HPCO)

This control's sensor is located in the discharge line. This device will shut off the compressor and the outdoor fan(s) if the discharge pressure exceeds the High Pressure Cut-Out's setting. Once the discharge pressure has returned to normal, the compressor will cycle back on.

⚠ WARNING

Prevent Injury!

Due to agency safety requirements, no schrader core is to be installed beneath the HPCO. Removal of the HPCO without evacuating the system charge could cause injury and release of refrigerant.

Internal Overload Protector (IOL)

This device is embedded in the compressor. It will shut off the compressor if the discharge temperature of the compressor exceeds its design trip temperature.

Note: The IOL will put the compressor back in operation once the compressor motor heat has dropped below the trip setting; however, a check of the refrigerant and electrical systems should be made to determine the cause and be corrected.

Refrigerant Leak Detector Input

All Odyssey units with Symbio 700 controls have a dedicated binary input for notification of a refrigerant leak event. This input will receive a normally closed 24VAC source and when open, triggers a refrigerant leak diagnostic allowing the Symbio 700 to take mitigation actions.

Troubleshooting

⚠ WARNING

Live Electrical Components!

Failure to follow all electrical safety precautions when exposed to live electrical components could result in death or serious injury.

When it is necessary to work with live electrical components, have a qualified licensed electrician or other individual who has been properly trained in handling live electrical components perform these tasks.

Refer to the latest version of the Symbio™ 700 Controller with Odyssey Split Systems Applications Guide (ACC-APG001*-EN) for details on troubleshooting the control system.

Leak Detection System

Note: The leak detection system referenced in this document refers specifically to a matched system containing only a TTA/TWE matched combination. If the installed system utilizes condensing units or AHUs other than listed above, it is the installers responsibility to ensure all necessary leak detection system hardware and communication is provided and installed for safe equipment installation and operation.

The leak detection sensor offers a visual diagnostic status in the form of one green and one red LED to indicate diagnostic error state.

Table 7. Leak detection system LED status

State	Green LED	Red LED
Power up initiate	ON	OFF
Failure resulting in a 'Power-UP Self-Test' Fail-safe State	ON	ON
Warm Up Delay	ON	OFF
Normal Runtime Mode	Heartbeat	OFF
LFL Alarm	OFF	ON
Failure resulting in a Fail-safe State	OFF	Blinking
Near end of life	Blinking	Heartbeat
Warning	ON	Heartbeat

Service Test Mode

The Symbio™ 700 supports a Service Test Mode that can be used to energize the various components of the system, either to support general system startup tasks or to support troubleshooting. The user can initiate Service Test Mode through the controller user interfaces, including the Symbio Service and Installation mobile application.

The modes shown below can be initiated. Depending on the equipment configuration, the controller will energize the appropriate outputs. A user-selected timeout value will determine how long the controller will remain in any given state once initiated. For detailed information on how each Service Test State is interpreted based on the equipment's configuration, refer to the *Symbio™ 700 Controller Application Guide* (ACC-APG001*-EN).

Figure 19. Symbio 700 service test mode

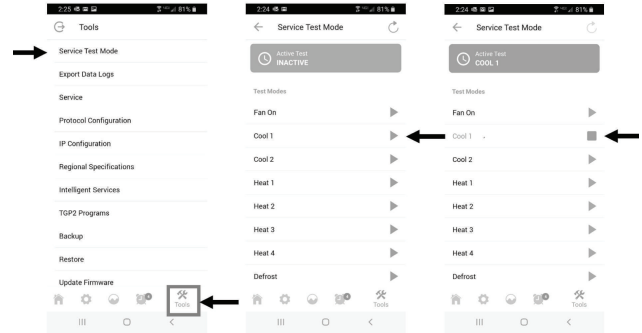

Maintenance

⚠ WARNING

Hazardous Voltage w/Capacitors!

Failure to disconnect power and discharge capacitors before servicing could result in death or serious injury.

Disconnect all electric power, including remote disconnects and discharge all motor start/run capacitors before servicing. Follow proper lockout/tagout procedures to ensure the power cannot be inadvertently energized. For variable frequency drives or other energy storing components provided by Trane or others, refer to the appropriate manufacturer's literature for allowable waiting periods for discharge of capacitors. Verify with a CAT III or IV voltmeter rated per NFPA 70E that all capacitors have discharged.

NOTICE

Operating Under Vacuum!

Failure to follow these instructions will result in compressor failure.

Do not operate or apply power to the compressor while under a vacuum.

Perform all of the indicated maintenance procedures at the intervals scheduled. This will prolong the life of the unit and reduce the possibility of costly equipment failure.

Monthly

Conduct the following maintenance inspections once per month.

- Check unit wiring to ensure all connections are tight and that the wiring insulation is intact.
- Inspect the condenser coils for dirt and debris. If the coils appear dirty, clean them.
- With the unit operating in the cooling mode, check the suction and discharge pressures and compare them with Pressure Curve values. Record these readings on the ["Maintenance Log," p. 35.](#)

Annually (Cooling Season)

The following maintenance procedures must be performed at the beginning of each cooling season to ensure efficient unit operation.

- Perform all of the monthly maintenance inspections.
- With the unit operating, check unit superheat and record the reading in the ["Maintenance Log," p. 35.](#)
- Remove any accumulation of dust and/or dirt from the unit casing.
- Remove corrosion from any surface and repaint. Check

the gasket around the control panel door to ensure it fits correctly and is in good condition to prevent water leakage.

- Inspect the control panel wiring to ensure that all connections are tight and that the insulation is intact.

Note: *Condenser fan motors are permanently lubricated.*

- Check refrigerant piping and fittings for leaks
- Inspect the condenser coils for dirt and debris. If the coils appear dirty, clean them.

Coil Cleaning

Regular coil maintenance, including annual cleaning—enhances the unit's operating efficiency by minimizing:

- compressor head pressure and amperage draw
- water carryover
- fan brake horsepower
- static pressure losses

At least once each year — or more often if the unit is located in a "dirty" environment — clean the coil using the instructions outlined below. Be sure to follow these instructions as closely as possible to avoid damaging the coils.

Tube and Fin

Note: *To clean refrigerant coils, use a soft brush and a sprayer. Contact your local Parts Center for appropriate detergents.*

1. Remove enough panels from the unit to gain safe access to coil.
2. Straighten any bent coil fins with a fin comb.
3. Remove loose dirt and debris from both sides of the coil with a soft brush.
4. Mix the detergent with water according to the manufacturer's instructions. If desired, heat the solution to 150° F maximum to improve its cleansing capability.
5. Pour the cleaning solution into the sprayer.
6. Spray the leaving-airflow side of the coil first; then spray the opposite side of the coil. Allow the cleaning solution to stand on the coil for five minutes.
7. Rinse both sides of the coil with cool, clean water.
8. Inspect both sides of the coil; if it still appears to be dirty, repeat Step 7 and 8.
9. Reinstall all of the components and panels removed in Step 1; then restore power to the unit.
10. Using a fin comb, straighten any coil fins that were inadvertently bent during the cleaning process.

Charging Data and Pressure Curves

Table 8. TWA Charging data and pressure curves

Condenser	Air Handler	Refrigerant Charging Curve Superheat and Charge Table	Pressure Curves
TWA072K*A	TWE090K*A	436768330001	436768450001
TWA072K*D	TWE072K*B	436768340001	436768460001
TWA090K*A	TWE090K*A	436768350001	436768470001
TWA090K*D	TWE090K*B	436768360001	436768480001
TWA120K*A	TWE120K*A	436768370001	436768490001
TWA120K*D	TWE120K*B	436768380001	436768500001
TWA180K*D	TWE180K*B	436768390001	436768390001
TWA240K*D	TWE240K*B	436768400001	436768400001

Wiring Diagram Matrix and Device Location

Table 9. TTA wiring diagrams

Part Number	Description	Applicability
1213-4781	Power Schematic (Wiring Diagram) for units with Dual Compressors and Dual Fans	All Units with Digit 4-6 = 180/240
1213-4782	Power Schematic (Wiring Diagram) for units with Dual Compressors and Single Fans	All Units with Digit 4-6 = 072/090/120 and Digit 9 = "D"
1213-4780	Power Schematic (Wiring Diagram) for units with Single Compressors and Single Fan	All Units with Digit 4-6 = 072/090/120 and Digit 9 = "A"
1213-4771	Control Schematic (Wiring Diagram) for units with Single compressor and Single Fan	All TWA Units with Digit 4-6 = 072/090/120 and Digit 9 = "A"
1213-4773	Control Schematic (Wiring Diagram) for units with Dual compressor and Single Fan	All TWA Units with Digit 4-6 = 072/090 and Digit 9 = "D"
1213-4775	Control Schematic (Wiring Diagram) for units with Dual compressor and Dual Fan	All TWA Units with Digit 4-6 = 180/240 and Digit 9 = "D"
1213-4772	Control Schematic (Wiring Diagram) for units with Single Compressor (Unloading) and Single Fan	All TWA Units with Digit 4-6 = 090/120 and Digit 9 = "A"
1213-4774	Control Schematic (Wiring Diagram) for units with Dual compressor (Unloading) and Single Fan	All TWA Units with Digit 4-6 = 120 and Digit 9 = "D"

Table 10. TWA device location

Part Number	Description	Applicability
1213-4823	Device Location Print	All TWA Units with Digit 4-6 = 072/090/120/150
1213-4824	Device Location Print	All TWA Units with Digit 4-6 = 180/240/300

Warranty

For Commercial Unitary Equipment Rated 25 Tons and Under and Related Accessories

Products Covered — This warranty is extended by Trane, and applies to the following products:

- All packaged and split system air conditioners and heat pumps have a rated capacity of 25 tons and under.
- All packaged combinations gas/electric air conditioners having a rated capacity of 25 tons and under.
- All packaged combination gas/electric air conditioners having a rated capacity of 1.5 through 5 tons single phase electric power and used for commercial applications. (As used in this warranty, a commercial application is any application where the end purchaser uses the product for other than personal, family or household purposes.)
- All accessories for the above products which are sold by Trane and applied in accordance with Trane specifications.

Basic Warranty

The warrantor warrants for a period of twelve (12) months from the initial start-up or eighteen (18) months from date of shipment, whichever is sooner, that the products covered by this warranty (1) are free from defects in material and manufacture, and (2) have the capacities and ratings set forth in the warrantor's catalogs and bulletins. If any part of your air conditioner fails because of a manufacturing defect, Warrantor will furnish without charge the required replacement part.

Any local transportation, related service labor and diagnosis calls are not included. In addition, if the sealed motor-compressor fails because of a manufacturing defect within the second through fifth year from the date of original purchase, Warrantor will furnish without charge the required replacement compressor.

Exclusions and Limitations

The warrantor's obligations and liabilities under this warranty are limited to furnishing F.O.B. factory or warehouse at the warrantor-designated shipping point, freight allowed to Buyer's city (or port of export for

shipments outside the conterminous United States) a replacement product or, at the option of the warrantor, parts for the repair of the product not conforming to this warranty and which have been returned to the warrantor.

The warrantor's warranty is conditional on the Customer providing written notice to the warrantor within thirty (30) days of the discovery of the defect. No product shall be returned to the warrantor without the warrantor's written permission. No liability whatever shall attach to warrantor until said products have been fully paid for and then said liability shall be limited to the purchase price of the equipment shown to be defective.

The warranty does not apply to any compressor or gas-fired heat exchanger which has been repaired or altered in such manner as, in the judgement of the warrantor, affects its stability or reliability. This warranty does not cover (1) any heat exchanger which has been fired with an improper type of fuel (2) a heat exchanger which is installed in a beauty parlor, dry cleaning establishment, de-greasing plant or in any corrosive atmosphere; or (3) any heat exchanger which is not shown to be defective by the warrantor's inspection.

This warranty does not cover damage due to accident, abuse, improper use, external causes, freezing, corrosion, erosion or deterioration. Local transportation, related service labor, air filters, diagnosis calls, refrigerant and related items are not covered.

THE WARRANTY AND LIABILITY SET FORTH HEREIN ARE IN LIEU OF ALL OTHER WARRANTIES AND LIABILITIES, WHETHER IN CONTRACT OR IN NEGLIGENCE, EXPRESS OR IMPLIED, IN LAW OR IN FACT, INCLUDING IMPLIED WARRANTIES OR MERCHANTABILITY AND FITNESS FOR A PARTICULAR PURPOSE AND ANY IMPLIED WARRANTIES OTHERWISE ARISING FROM THE COURSE OF DEALING OR TRADE. IN NO EVENT SHALL THE WARRANTOR BE LIABLE FOR ANY INCIDENTAL OR CONSEQUENTIAL DAMAGES.

The warrantor makes certain further warranty protection available on an optional, extra-cost basis. Any further warranty must be in writing. If you wish further help or information concerning this warranty, contact: Trane — Warrantor, 2701 Wilma Rudolph Blvd., Clarksville, TN 37040

Trane and American Standard create comfortable, energy efficient indoor environments for commercial and residential applications. For more information, please visit trane.com or americanstandardair.com.

Trane and American Standard have a policy of continuous product and product data improvement and reserve the right to change design and specifications without notice. We are committed to using environmentally conscious print practices.