

Installation, Operation, and Maintenance

Split System Air Conditioners

Odyssey™ with Symbio™

Controls

Cooling Condenser, R-410A 5 to 25 Tons

(60 Hz)

TTA0724*A/D
TTA0904*A/D
TTA1204*C/D
TTA1504*D
TTA1804*C/D
TTA2404*C/D
TTA3004*C

(50 Hz)

TTA0604DA/D
TTA0764DA/D
TTA1014DC/D
TTA1264DD
TTA1564DC/D
TTA2014DC/D
TTA2514DC

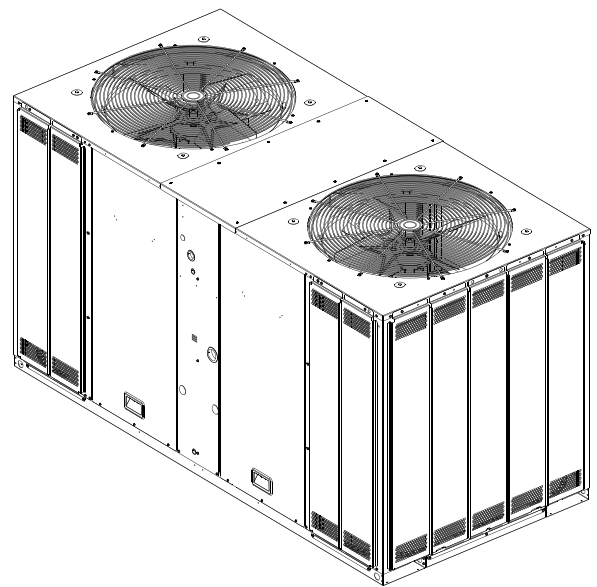

▲ SAFETY WARNING

Only qualified personnel should install and service the equipment. The installation, starting up, and servicing of heating, ventilating, and air-conditioning equipment can be hazardous and requires specific knowledge and training. Improperly installed, adjusted or altered equipment by an unqualified person could result in death or serious injury. When working on the equipment, observe all precautions in the literature and on the tags, stickers, and labels that are attached to the equipment.

Introduction

Read this manual thoroughly before operating or servicing this unit.

Warnings, Cautions, and Notices

Safety advisories appear throughout this manual as required. Your personal safety and the proper operation of this machine depend upon the strict observance of these precautions.

The three types of advisories are defined as follows:



Indicates a potentially hazardous situation which, if not avoided, could result in death or serious injury.



Indicates a potentially hazardous situation which, if not avoided, could result in minor or moderate injury. It could also be used to alert against unsafe practices.

NOTICE

Indicates a situation that could result in equipment or property-damage only accidents.

Important Environmental Concerns

Scientific research has shown that certain man-made chemicals can affect the earth's naturally occurring stratospheric ozone layer when released to the atmosphere. In particular, several of the identified chemicals that may affect the ozone layer are refrigerants that contain Chlorine, Fluorine and Carbon (CFCs) and those containing Hydrogen, Chlorine, Fluorine and Carbon (HCFCs). Not all refrigerants containing these compounds have the same potential impact to the environment. Trane advocates the responsible handling of all refrigerants.

Important Responsible Refrigerant Practices

Trane believes that responsible refrigerant practices are important to the environment, our customers, and the air conditioning industry. All technicians who handle refrigerants must be certified according to local rules. For the USA, the Federal Clean Air Act (Section 608) sets forth the requirements for handling, reclaiming, recovering and recycling of certain refrigerants and the equipment that is used in these service procedures. In addition, some states or municipalities may have additional requirements that must also be adhered to for responsible management of refrigerants. Know the applicable laws and follow them.

⚠ WARNING

Proper Field Wiring and Grounding Required!

Failure to follow code could result in death or serious injury.

All field wiring MUST be performed by qualified personnel. Improperly installed and grounded field wiring poses FIRE and ELECTROCUTION hazards. To avoid these hazards, you MUST follow requirements for field wiring installation and grounding as described in NEC and your local/state/national electrical codes.

⚠ WARNING

Personal Protective Equipment (PPE) Required!

Failure to wear proper PPE for the job being undertaken could result in death or serious injury.

Technicians, in order to protect themselves from potential electrical, mechanical, and chemical hazards, **MUST follow precautions in this manual and on the tags, stickers, and labels, as well as the instructions below:**

- **Before installing/servicing this unit, technicians MUST put on all PPE required for the work being undertaken (Examples; cut resistant gloves/sleeves, butyl gloves, safety glasses, hard hat/bump cap, fall protection, electrical PPE and arc flash clothing). ALWAYS refer to appropriate Safety Data Sheets (SDS) and OSHA guidelines for proper PPE.**
- **When working with or around hazardous chemicals, ALWAYS refer to the appropriate SDS and OSHA/GHS (Global Harmonized System of Classification and Labelling of Chemicals) guidelines for information on allowable personal exposure levels, proper respiratory protection and handling instructions.**
- **If there is a risk of energized electrical contact, arc, or flash, technicians MUST put on all PPE in accordance with OSHA, NFPA 70E, or other country-specific requirements for arc flash protection, PRIOR to servicing the unit. NEVER PERFORM ANY SWITCHING, DISCONNECTING, OR VOLTAGE TESTING WITHOUT PROPER ELECTRICAL PPE AND ARC FLASH CLOTHING. ENSURE ELECTRICAL METERS AND EQUIPMENT ARE PROPERLY RATED FOR INTENDED VOLTAGE.**

⚠ WARNING**Follow EHS Policies!**

Failure to follow instructions below could result in death or serious injury.

- All Trane personnel must follow the company's Environmental, Health and Safety (EHS) policies when performing work such as hot work, electrical, fall protection, lockout/tagout, refrigerant handling, etc. Where local regulations are more stringent than these policies, those regulations supersede these policies.
- Non-Trane personnel should always follow local regulations.

⚠ WARNING**Refrigerant under High Pressure!**

Failure to follow instructions below could result in an explosion which could result in death or serious injury or equipment damage.

System contains refrigerant under high pressure. Recover refrigerant to relieve pressure before opening the system. See unit nameplate for refrigerant type. Do not use non-approved refrigerants, refrigerant substitutes, or refrigerant additives.

⚠ WARNING**Explosion Hazard!**

Failure to follow instructions below could result in an explosion which could result in death or serious injury, and equipment damage.

NEVER bypass system safeties in order to pump down the unit component's refrigerant into the microchannel heat exchanger (MCHE) coil. Do NOT depress the compressor contactor since it effectively bypasses the high-pressure control.

⚠ WARNING**Refrigerant under High Pressure!**

Failure to follow instructions below could result in an explosion which could result in death or serious injury or equipment damage.

System contains refrigerant under high pressure. Recover refrigerant to relieve pressure before opening the system. See unit nameplate for refrigerant type. Do not use non-approved refrigerants, refrigerant substitutes, or refrigerant additives.

Copyright

This document and the information in it are the property of Trane, and may not be used or reproduced in whole or in part without written permission. Trane reserves the right to revise this publication at any time, and to make changes to its content without obligation to notify any person of such revision or change.

Trademarks

All trademarks referenced in this document are the trademarks of their respective owners.

Revision History

- Updated the Model Number Description chapter.
- Updated the Installation chapter.
- Updated the Charging Data and Pressure Curves chapter.
- Updated the Dimensional Data chapter.

Table of Contents

Model Number Description	5	Liquid Charging	27
Cooling Condenser	5	Electrical Wiring	27
General Information	6	Unit Power Supply	28
Unit Description	6	Low Voltage Wiring	28
Pre-Installation	7	Symbio™ Controls	28
Unit Inspection	7	Field Wiring	30
Inspection Checklist	7	Refrigerant Circuit	30
Testing for Leaks	7	Pre-Start	31
Lifting Recommendations	7	Control Circuit Features	31
Clearances	7	Discharge Temperature Limit	
Unit Mounting	8	(DTL)	31
Structural Preparation	8	Low Outdoor Ambient Cooling	31
Rooftop Mounting	8	Evaporator Defrost Control (EDC)	31
Ground Level Mounting	8	Low Pressure Cut-Out (LPC)	31
Installation Checklist	8	High Pressure Cut-Out (HPCO)	31
Refrigerant Piping	8	Internal Overload Protector (IOL)	31
Electrical Wiring	8	Troubleshooting	32
Dimensional Data	9	Service Test Mode	33
Cooling Condenser	9	Maintenance	34
Weights	18	Monthly	34
Cooling Condenser	18	Annually (Cooling Season)	34
Installation	20	Coil Cleaning	34
Refrigerant Piping Guidelines	20	Microchannel (MCHE) Coils	34
Refrigerant Piping Procedures (Outdoor		Maintenance Log	35
Units)	22	Charging Data and Pressure Curves	36
Refrigerant Piping Procedures (Indoor		Wiring Diagram Matrix and Device	
Unit)	23	Location	37
Leak Check	23	Warranty	38
System Evacuation	24	For Commercial Unitary Equipment Rated	
Insulating and Isolating Refrigerant		25 Tons and Under and Related	
Lines	24	Accessories	38
Refrigerant Charging Procedure	24	Basic Warranty	38
Charging Levels	26	Exclusions and Limitations	38

Model Number Description

Cooling Condenser

Digit 1, 2, 3 — Unit Function

TTA = Split System Cooling

Digit 4, 5, 6 — Tonnage

060 = 5 Tons (50Hz)
072 = 6 Tons (60 Hz)
076 = 6.25 Tons (50Hz)
090 = 7.5 Tons (60 Hz)
101 = 8.33 Tons (50Hz)
120 = 10 Tons (60 Hz)
126 = 10.4 Tons (50Hz)
150 = 12.5 Tons (60 Hz)
156 = 13.0 Tons (50Hz)
180 = 15 Tons (60 Hz)
201 = 16.7 Tons (50Hz)
240 = 20 Tons (60 Hz)
251 = 20.9 Tons (50Hz)
300 = 25 Tons (60Hz)

Digit 7 — Refrigerant

4 = R-410A

Digit 8 — Voltage

3 = 208-230 Vac - 3 PH (60Hz)
4 = 460 Vac - 3 PH (60Hz)
W = 575 Vac - 3 PH (60Hz)
D = 380-415 Vac- 3 PH (50Hz)
K = 380 Vac - 3 PH (60Hz)

Digit 9 — Refrigeration Circuit/Stage

A = 1 Compressor/1 Line/1 Stage (Single)
C = 2 Compressors/1 Line/2 Stage (Manifold)
D = 2 Compressors/2 Line/2 Stage (Dual)

Digit 10 — Major Design Sequence

A = Rev A
B = Rev B

Digit 11 — Minor Design Sequence

C = Rev C

Digit 12, 13 — Service Digits

**

Digit 14 — Efficiency Generation

A = Generation A
B = Generation B

Digit 15 — Controls

S = Symbio™

Digit 16 — None

0 = None

Digit 17 — Coil Protection

0 = Standard Coil
1 = Standard Coil w/ Coil Guard
4 = Complete Coat Condenser Coil (MCHE)
5 = Complete Coat Condenser Coil with Coil Guard (MCHE)

Digit 18, 19, 20 — None

0 = None

Digit 21 — Communications Options

0 = No Option
1 = Advanced Diagnostics and BACnet® BAS
2 = Advanced Diagnostics and LonTalk® Communications Interface (LCI)

Digit 22 to 40 — None

0 = None

General Information

This manual describes proper installation, operation, and maintenance procedures for air-cooled systems. By carefully reviewing the information within this manual and following the instructions, the risk of improper operation and/or component damage will be minimized. It is important that periodic maintenance be performed to help assure trouble free operation. Should equipment failure occur, contact a qualified service organization with qualified, experienced HVAC technicians to properly diagnose and repair this equipment.

Important: *All phases of this installation must comply with the NATIONAL, STATE and LOCAL CODES. In addition to local codes, the installation must conform with National Electric Code -ANSI/ NFPA NO. 70 LATEST REVISION.*

Any individual installing, maintaining, or servicing this equipment must be properly trained, licensed and qualified.

Important: *Do not remove the VFD without first contacting technical support! For performance-related questions and diagnostic support in North America call 1-877-872-6363. Any return requires a claim number FIRST. Removal of the VFD prior to this step will void the unit's warranties.*

Installation procedures should be performed in the sequence that they appear in this manual. Do not destroy or remove the manual from the unit. The manual should remain weather-protected with the unit until all installation procedures are complete.

Note: *It is not the intention of this manual to cover all possible variations in systems that may occur or to provide comprehensive information concerning every possible contingency that may be encountered during an installation. If additional information is required or if specific problems arise that are not fully discussed in this manual, contact your local sales office.*

Use the “[Installation Checklist](#),” p. 8 provided in this manual to verify that all necessary installation procedures have been completed. Do not use the checklist as a substitute for reading the information contained in this manual. Read this entire manual before beginning installation procedures.

Unit Description

These condensers come with single, dual and manifolded compressor options. Single compressor outdoor units feature a single refrigeration circuit requiring only one set of refrigerant lines. Dual compressor/dual circuit models give true stand-by protection; if one compressor fails, the second will automatically start-up. During light load conditions, only one compressor will operate to save energy. The dual manifolded scroll compressors come with two stages of capacity modulation and a single refrigeration circuit.

Pre-Installation

Unit Inspection

Inspect material carefully for any shipping damage. If damaged, it must be reported to, and claims made against the transportation company. Compare the information that appears on the unit nameplate with ordering and submittal data to ensure the proper unit was shipped. Available power supply must be compatible with electrical characteristics specified on component nameplates. Replace damaged parts with authorized parts only.

Important: Units ordered with a VFD cannot be field converted to 460 V from 208-230 or from 208-230 V to 460 V.

Inspection Checklist

To protect against loss due to damage incurred in transit, complete the following checklist upon receipt of the unit.

- Inspect individual pieces of the shipment before accepting the unit. Check for obvious damage to the unit or packing material.
- Inspect the unit for concealed damage before it is stored and as soon as possible after delivery. Concealed damage must be reported within 15 days. If concealed damage is discovered, stop unpacking the shipment. Do not remove damaged material from the receiving location. Take photos of the damage if possible. The owner must provide reasonable evidence that the damage did not occur after delivery.
- Notify the carrier's terminal of damage immediately by phone and by mail. Request an immediate joint inspection of the damage by the carrier and the consignee.
- Notify the sales representative and arrange for repair. Do not repair the unit until the damage is inspected by the carrier's representative.

Testing for Leaks

All units are shipped with a holding charge of nitrogen in each circuit and should be leak tested before installation.

1. Remove the access panel.
2. Locate the liquid line or suction line access valve for each circuit.
3. Install gauges to determine if the circuits are still pressurized. If not, the charge has escaped and should be repaired as required to obtain a leak-free circuit.

Lifting Recommendations

⚠ WARNING

Improper Unit Lift!

Failure to properly lift unit in a LEVEL position could result in unit dropping and possibly crushing operator/technician which could result in death or serious injury, and equipment or property-only damage.

Test lift unit approximately 24 inches (61 cm) to verify proper center of gravity lift point. To avoid dropping of unit, reposition lifting point if unit is not level.

NOTICE

Equipment Damage!

Use spreader bars to prevent straps from damaging the unit. Install the bars between lifting straps, both underneath the unit and above the unit to prevent the straps from crushing the unit cabinet or damaging the finish.

Before preparing the unit for lifting, estimate the approximate center of gravity for lifting safety. Because of placement of internal components, the unit weight may be unevenly distributed. See "Weights," p. 18 for approximate unit weights.

The crated unit can be moved using a forklift of suitable capacity. For lifting the unit, attach lifting straps or slings securely to the lifting holes at each corner (see unit drawings in "Weights," p. 18). Use spreader bars to protect the unit casing from damage. Test lift the unit to determine proper balance and stability.

Clearances

Provide enough space around the unit to allow unrestricted access to all service points. Refer to the "Dimensional Data," p. 9 for unit dimensions and minimum required service and free air clearances. Observe the following points to ensure proper unit operation.

1. Do not install the unit under a low overhang. Condenser discharge must not be restricted—refer to notes in "Dimensional Data drawings," p. 9.

Important: Do not obstruct condenser discharge air. This can result in warm air recirculation through the coil.

2. Do not locate the unit in a position where runoff water, or falling snow from roof, can fall into the fan discharge openings.
3. Condenser intake air is supplied from three or four sides of the unit. Adhere to the minimum required clearances given in unit dimensional drawings (see "Dimensional Data," p. 9).

Unit Mounting

⚠ WARNING

Risk of Roof Collapsing!

Failure to ensure proper structural roof support could cause the roof to collapse, which could result in death or serious injury and property damage.

Confirm with a structural engineer that the roof structure is strong enough to support the combined weight of the roofcurb, the unit, and any accessories.

Structural Preparation

NOTICE

Roof Damage!

System contains oil and refrigerant under high pressure. Roofs should be protected from exposure to oils and refrigerant in the system. If rooftop is not protected, damage to the roof may occur.

Important: Refer to local building codes for proper installation. All installation must comply with local building codes.

Rooftop Mounting

If the unit will be roof mounted, determine for certain that the structure is strong enough to support the unit and any required accessories, see “Weights,” p. 18. The unit should be elevated on a level, field fabricated four-inch steel or wood 4" x 4" mounting frame. Complete the frame and secure it into position before lifting the unit to the roof. The mounting frame must support a minimum of three of the unit's four sides and should span roof supports to distribute the load on the roof.

Figure 1. Roof mounted unit

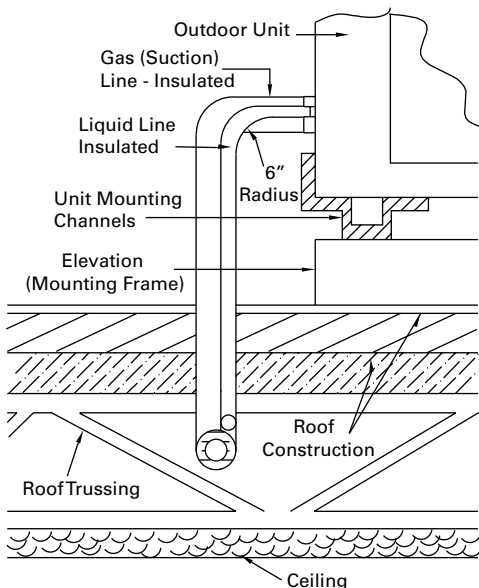

Ground Level Mounting

For ground level installation, the unit base should be adequately supported and hold the unit near level. The installation must meet the guidelines set forth in local codes. The support should extend two inches beyond the unit base channels at all points. The unit and support must be isolated from any adjacent structure to prevent possible noise or vibration problems. Any ground level location must comply with required clearances given in the unit dimensional drawings (see “Dimensional Data,” p. 9).

Installation Checklist

Complete this checklist once the unit is installed to verify that all recommended procedures have been accomplished before starting the system. Do not operate the system until all items covered by this checklist are complete.

- Inspect unit location for proper required service clearances.
- Inspect unit location for proper free air clearances.
- Inspect unit location for secure, level mounting position.
- Remove coil protection boards on microchannel units.
- Verify condenser fans turn freely without rubbing and are properly tightened on the shafts.

Refrigerant Piping

- Properly sized/constructed liquid and suction lines connected to stubs at both the indoor and outdoor units?
- Insulated the entire suction line?
- Insulated portions of liquid line exposed to extremes in temperature?
- Performed initial leak test?
- Evacuated each refrigerant circuit to 500 microns?
- Charged each circuit with proper amount of R-410A?

Electrical Wiring

- Provided unit power wiring (with disconnect) to proper terminals in the unit control enclosure?
- Installed system indoor thermostat or zone sensor?
- Installed system low voltage interconnecting wiring to proper terminals of outdoor unit, indoor unit and system thermostat or zone sensor?
- Checked all electrical connections to verify all are properly tightened and connected?
- Verified operation of crankcase heaters?

Dimensional Data

Cooling Condenser

Figure 2. Height, width and depth measurements

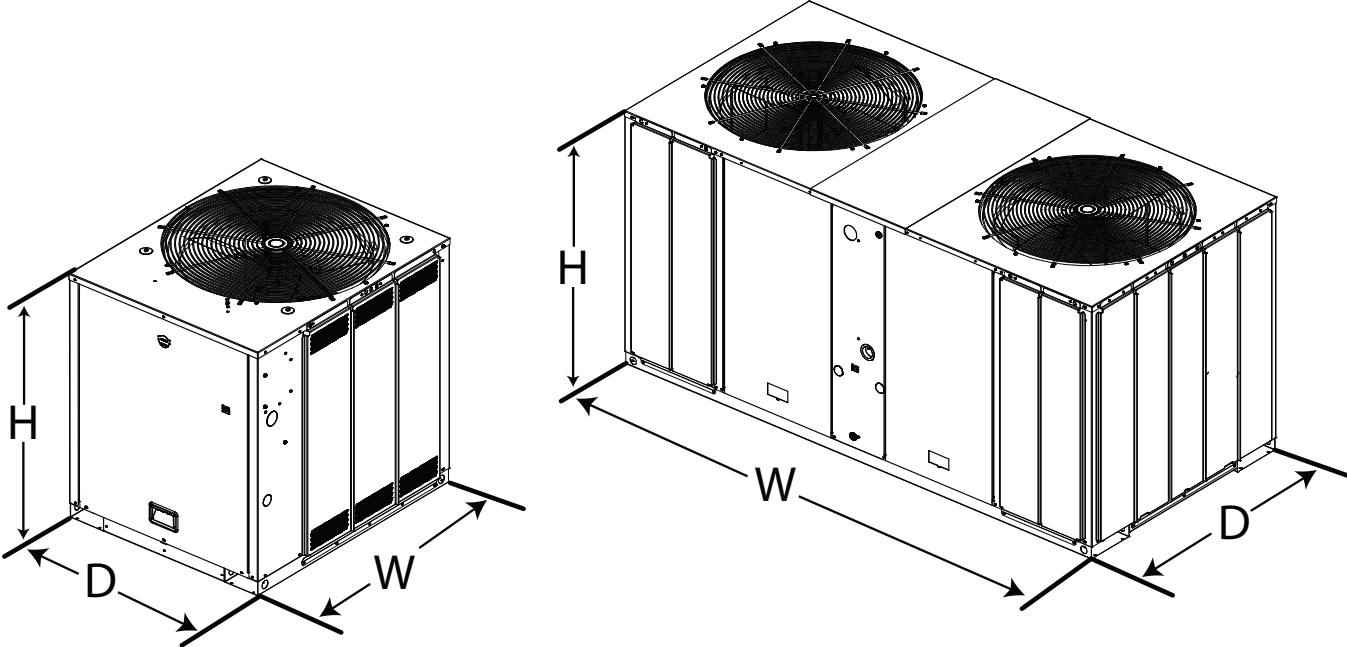

	H - in. (mm)	W - in. (mm)	D - in. (mm)
TTA060, 072, 076, 090	39.2 (996)	42.1 (1070)	36.3 (922)
TTA101, 120	39.2 (996)	51.9 (1317)	39.3 (999)
TTA126, 150	45.2 (1150)	51.9 (1317)	39.3 (999)
TTA156, 180, 201, 240	45.2 (1150)	94.8 (2407)	45.4 (1152)
TTA251, 300	51.2 (1302)	94.8 (2407)	45.4 (1152)

Note: Full dimensional data available on next pages.

Dimensional Data

Figure 3. 5, 6, 6.25, 7.5 ton R-410A condensing, single compressor – in (mm)

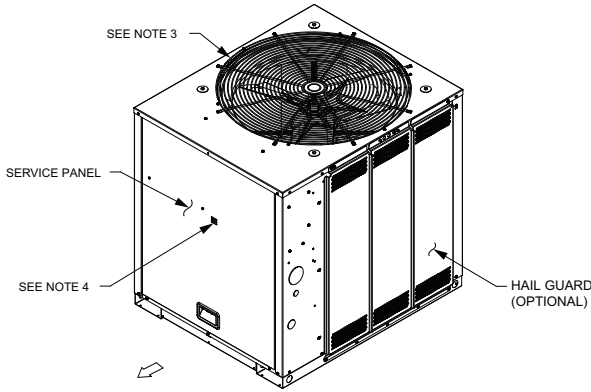

NOTES:

1. ACCESS OPENING IS FOR FIELD INSTALLED BAYLOAM ACCESSORY.
2. MINIMUM CLEARANCE FOR PROPER OPERATION IS 36" (914.4) FROM WALLS, SHRUBBERY, PRIVACY FENCES ETC. MINIMUM CLEARANCE BETWEEN ADJACENT UNITS IS 72" (1828.8). RECOMMENDED SERVICE CLEARANCE 48" (1219.2)
3. TOP DISCHARGE AREA SHOULD BE UNRESTRICTED FOR 100" (2540) MINIMUM. UNIT SHOULD BE PLACED SO ROOF RUN-OFF WATER OR FALLING SNOW FROM ROOF DOES NOT POUR/FALL DIRECTLY ON UNIT
4. OUTDOOR AIR TEMPERATURE SENSOR OPENING (DO NOT BLOCK OPENING)

SERVICE CLEARANCE
48" (1219.2) (SEE NOTE 2
FOR CLEARANCE)

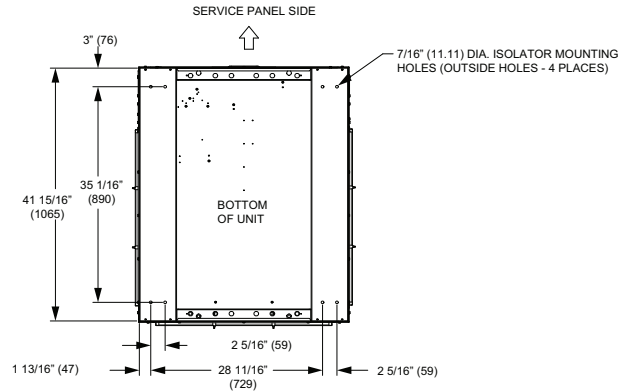
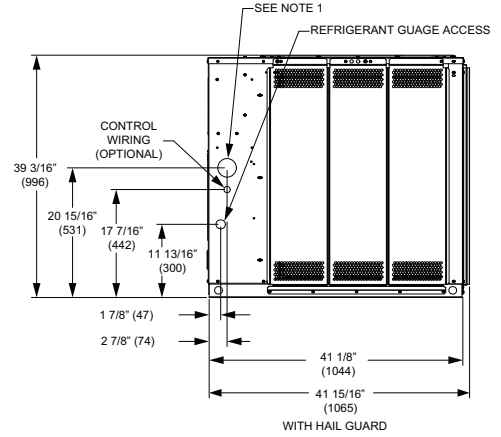
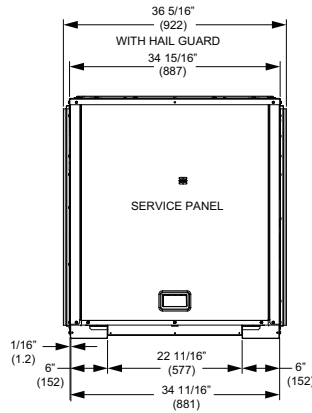
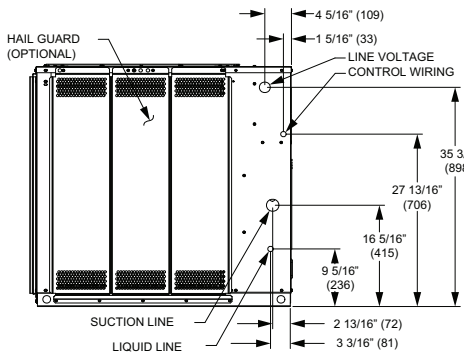
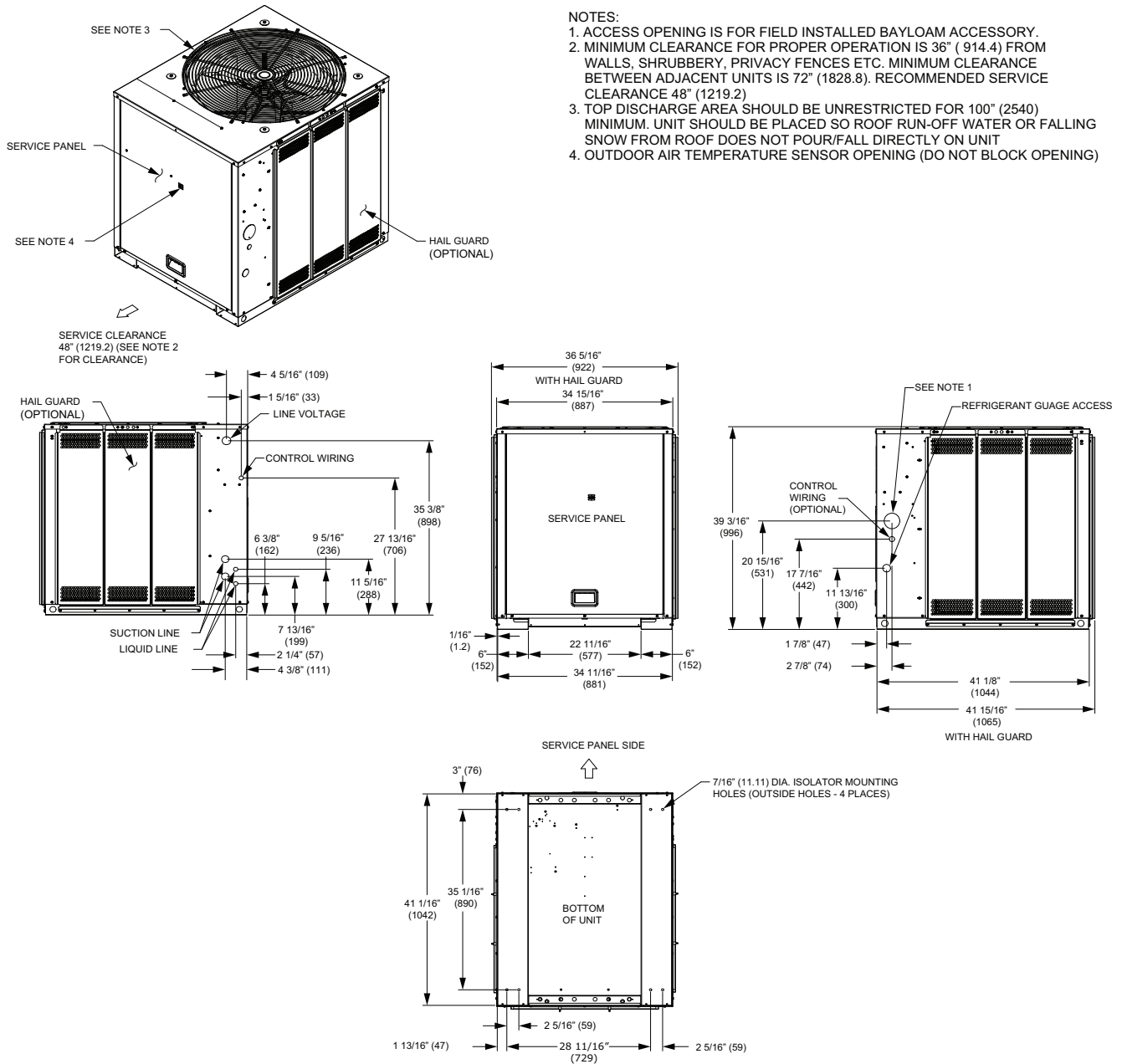

Figure 4. 5, 6, 6.25, 7.5 ton condensing, dual compressor – in (mm)



Dimensional Data

Figure 5. 8.33, 10 ton R-410A condensing, manifolded compressor – in (mm)

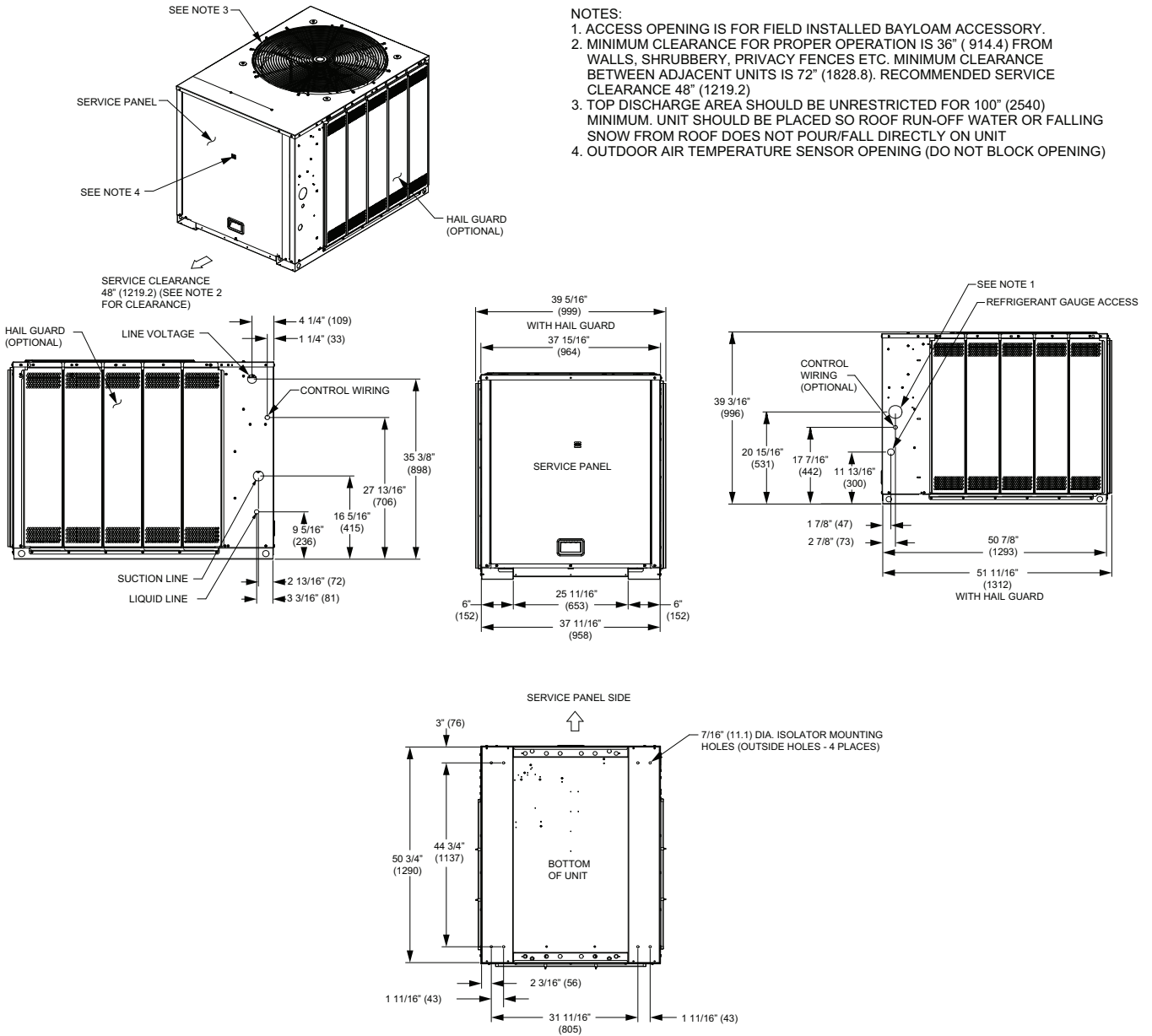
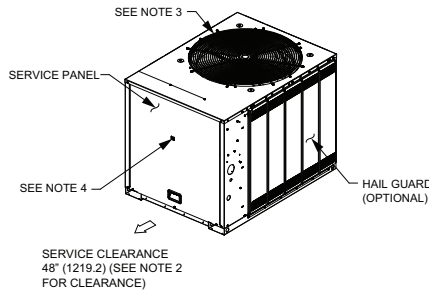
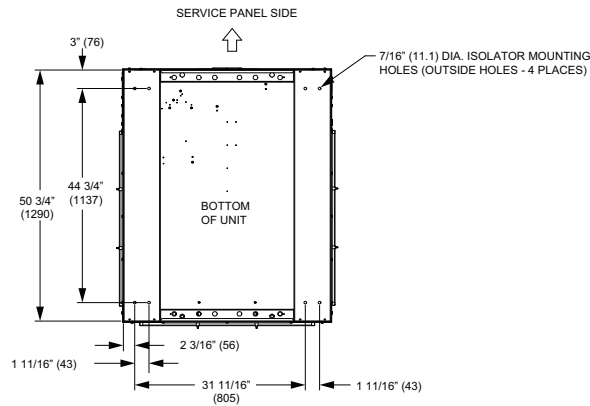
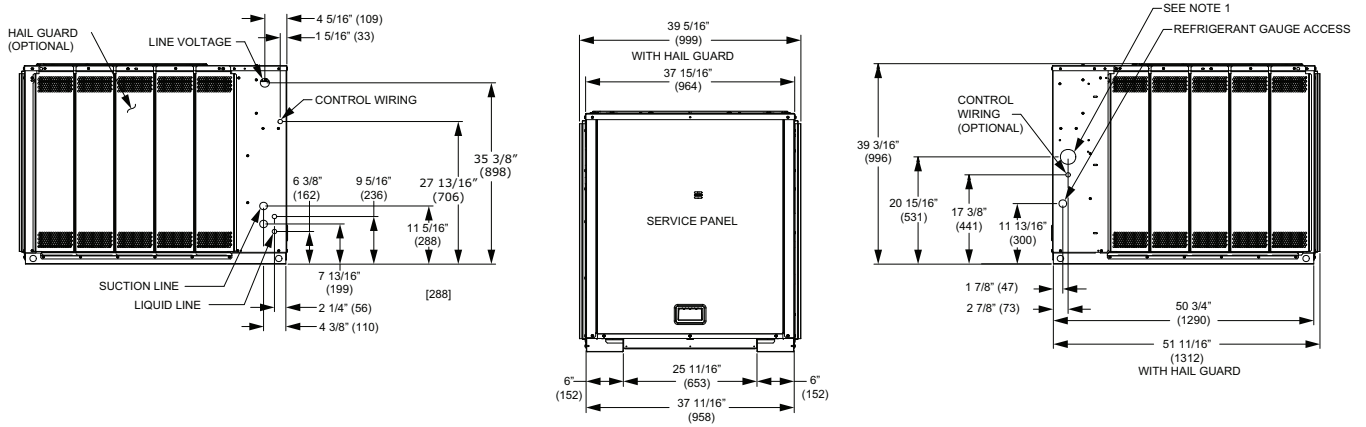

Figure 6. 8.33, 10 ton condensing, dual compressor – in (mm)



NOTES:

1. ACCESS OPENING IS FOR FIELD INSTALLED BAYLOAM ACCESSORY.
2. MINIMUM CLEARANCE FOR PROPER OPERATION IS 36" (914.4) FROM WALLS, SHRUBBERY, PRIVACY FENCES ETC. MINIMUM CLEARANCE BETWEEN ADJACENT UNITS IS 72" (1828.8). RECOMMENDED SERVICE CLEARANCE 48" (1219.2)
3. TOP DISCHARGE AREA SHOULD BE UNRESTRICTED FOR 100" (2540) MINIMUM. UNIT SHOULD BE PLACED SO ROOF RUN-OFF WATER OR FALLING SNOW FROM ROOF DOES NOT POUR/FALL DIRECTLY ON UNIT
4. OUTDOOR AIR TEMPERATURE SENSOR OPENING (DO NOT BLOCK OPENING)



Dimensional Data

Figure 7. 10.4, 12.5 ton condensing, dual compressor – in (mm)

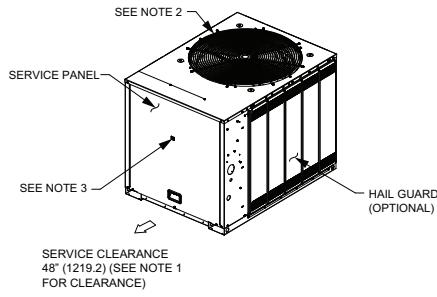

NOTES:

1. MINIMUM CLEARANCE FOR PROPER OPERATION IS 36" (914.4) FROM WALLS, SHRUBBERY, PRIVACY FENCES ETC. MINIMUM CLEARANCE BETWEEN ADJACENT UNITS IS 72" (1828.8). RECOMMENDED SERVICE CLEARANCE 48" (1219.2)
2. TOP DISCHARGE AREA SHOULD BE UNRESTRICTED FOR 100" (2540) MINIMUM. UNIT SHOULD BE PLACED SO ROOF RUN-OFF WATER OR FALLING SNOW FROM ROOF DOES NOT POUR/FALL DIRECTLY ON UNIT
3. OUTDOOR AIR TEMPERATURE SENSOR OPENING (DO NOT BLOCK OPENING)

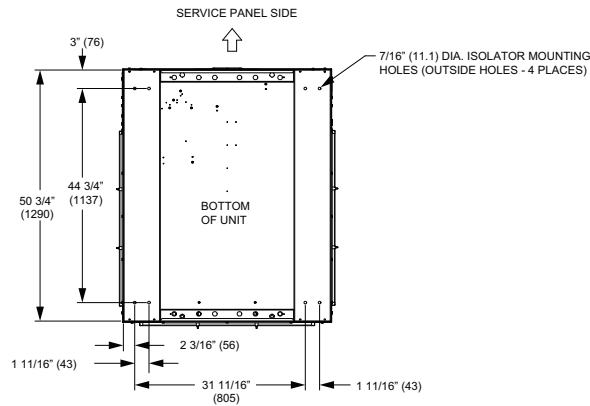
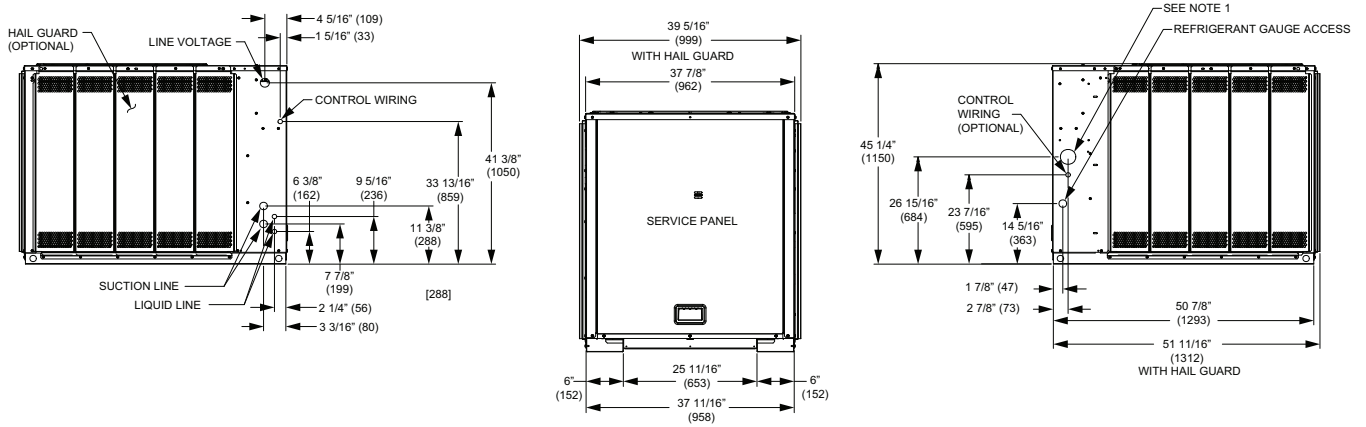
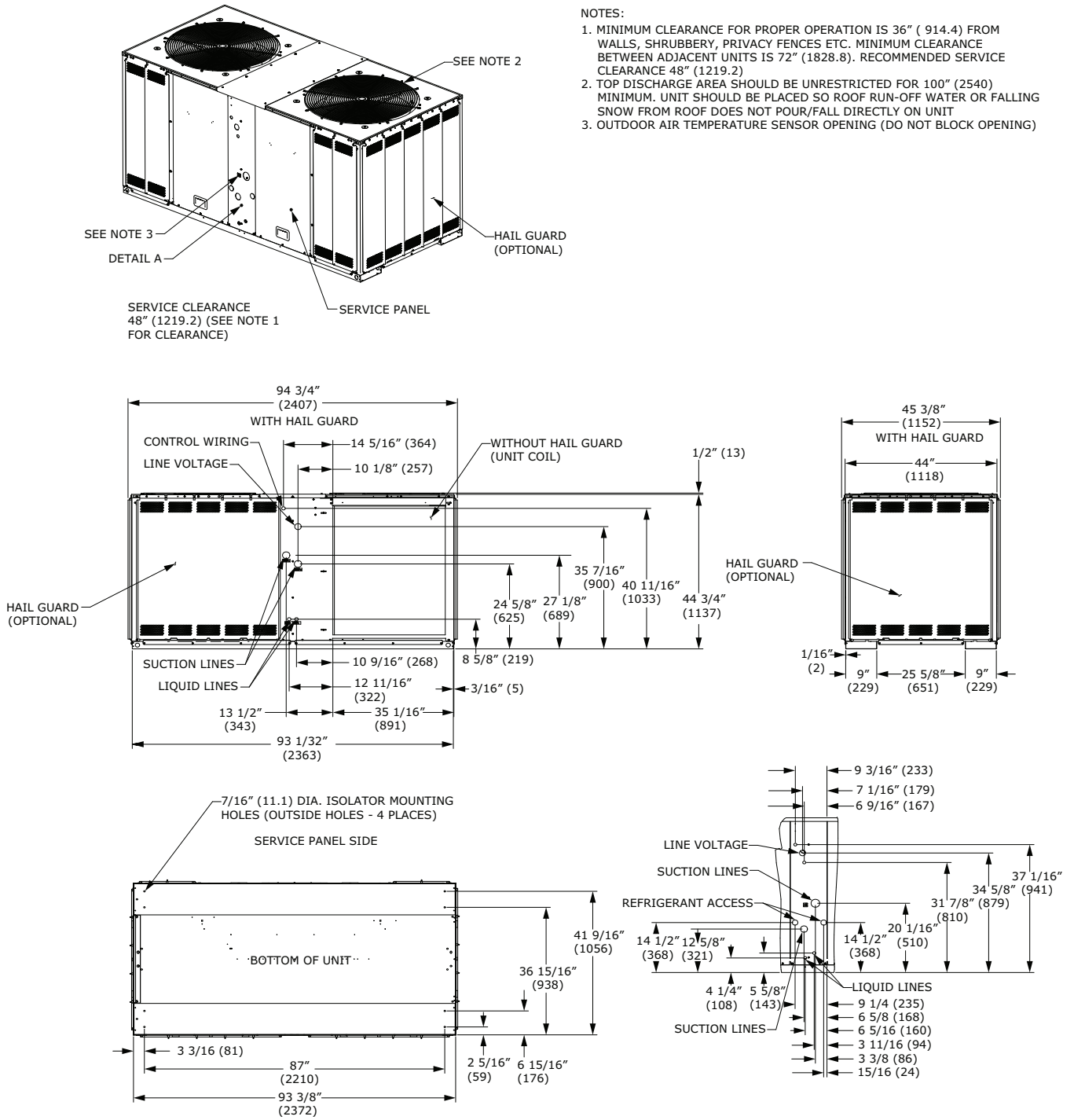

Figure 8. 13, 15, 16.7 and 20 ton R-410A condensing, dual compressor – in (mm)



Dimensional Data

Figure 9. 13, 15, 16.7 and 20 ton condensing, manifolded compressor – in (mm)

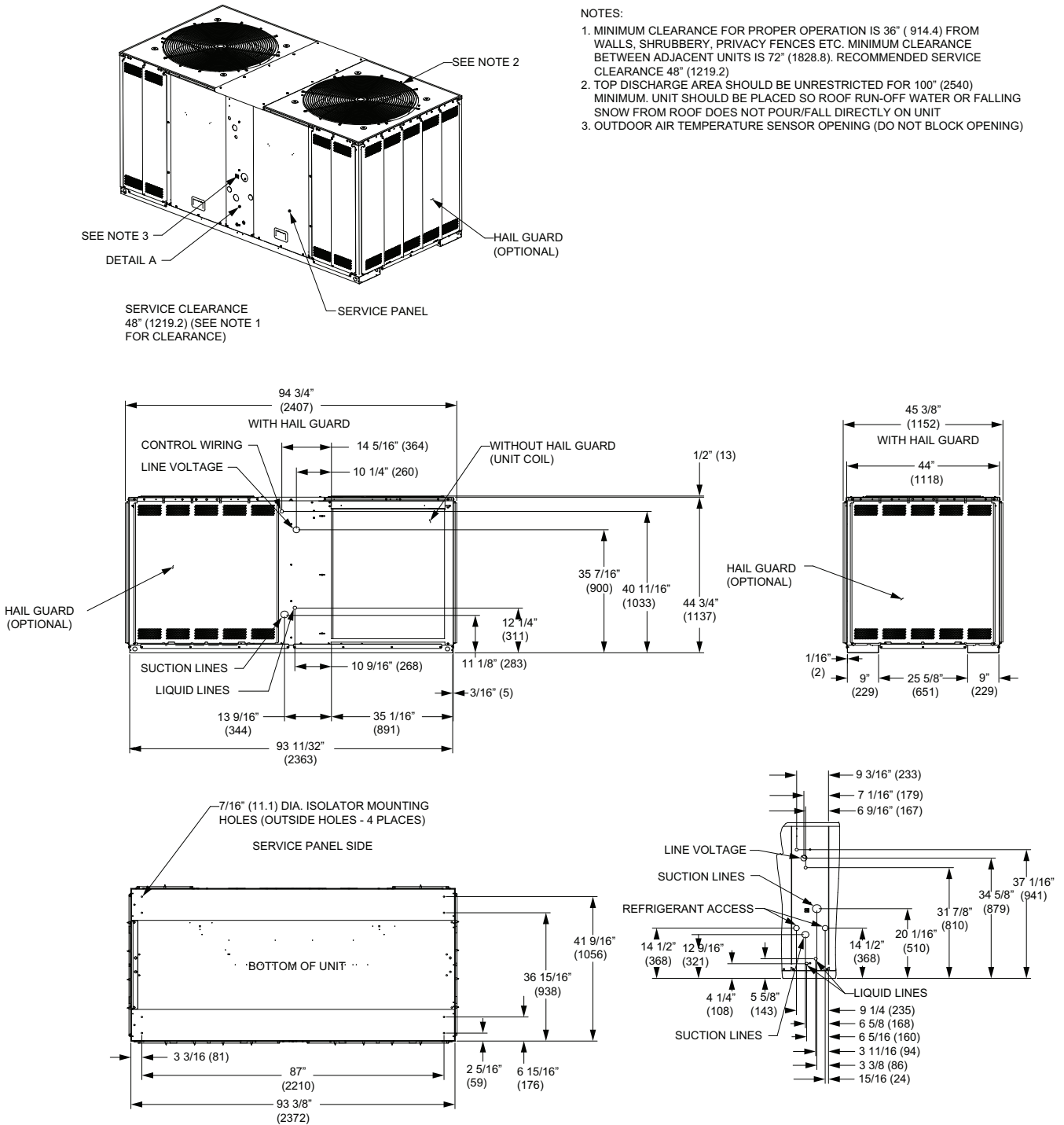
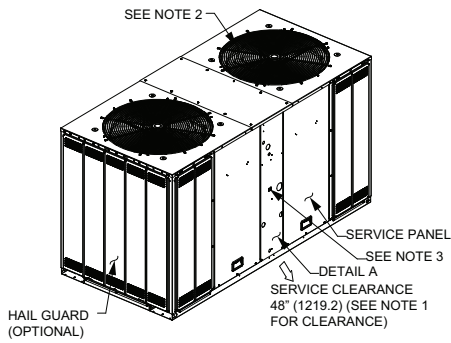
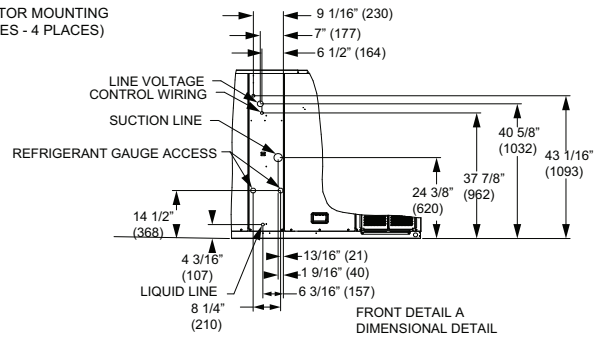
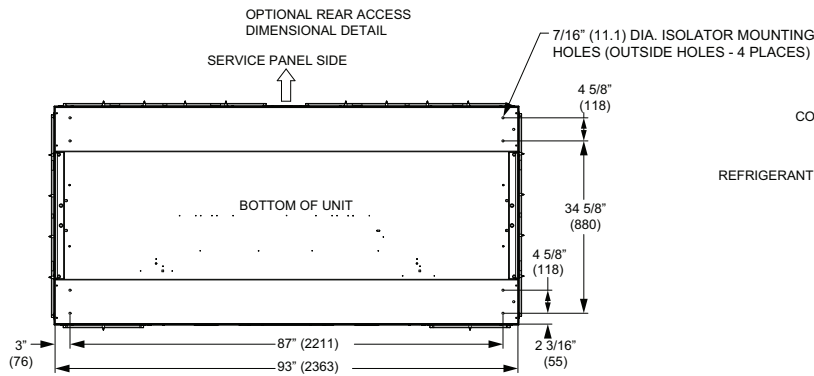
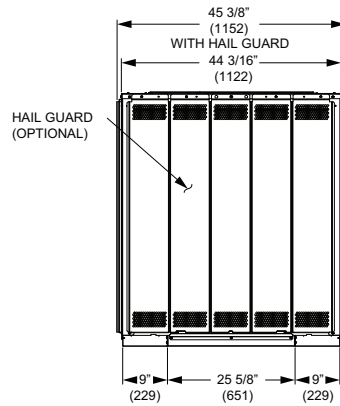
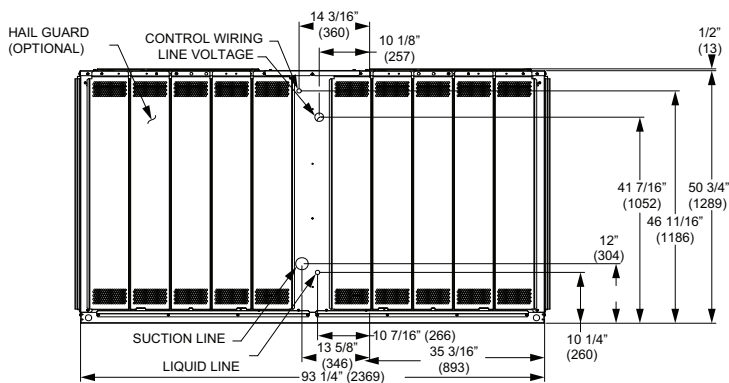

Figure 10. 20.9 and 25 ton condensing, manifolded compressor – in (mm)



NOTES:

1. MINIMUM CLEARANCE FOR PROPER OPERATION IS 36" (914.4) FROM WALLS, SHRUBBERY, PRIVACY FENCES ETC. MINIMUM CLEARANCE BETWEEN ADJACENT UNITS IS 72" (1828.8). RECOMMENDED SERVICE CLEARANCE 48" (1219.2)
2. TOP DISCHARGE AREA SHOULD BE UNRESTRICTED FOR 100' (2540) MINIMUM. UNIT SHOULD BE PLACED SO ROOF RUN-OFF WATER OR FALLING SNOW FROM ROOF DOES NOT POUR/FALL DIRECTLY ON UNIT
3. OUTDOOR AIR TEMPERATURE SENSOR OPENING (DO NOT BLOCK OPENING)



Weights

Cooling Condenser

Table 1. TTA R-410A unit and corner weights — lbs (60 Hz)

Tons	Model No.	Shipping Max (lbs)	Net Max (lbs)	Corner Weights			
				1	2	3	4
6	TTA0724*A	324	287	84	89	55	59
	TTA0724*D	344	307	97	89	64	57
7.5	TTA0904*A	342	305	87	94	59	65
	TTA0904*D	380	343	107	100	70	66
10	TTA1204*D	436	391	113	112	84	82
	TTA1204*C	473	428	127	127	87	87
12.5	TTA150*D	504	459	138	137	92	92
15	TTA1804*D	806	705	194	195	158	158
	TTA1804*C	806	705	192	192	161	160
20	TTA2404*D	872	771	214	214	171	172
	TTA2404*C	879	778	218	220	169	171
25	TTA3004*C	1013	912	258	260	196	198

Table 2. TTA R-410A unit and corner weights — kg (50 Hz)

Tons	Model No.	Shipping Max (kg)	Net Max (kg)	Corner Weights			
				1	2	3	4
5	TTA0604DA	146	129	38	40	25	26
	TTA0604DD	154	137	43	40	28	26
6.25	TTA0764DA	155	138	39	43	27	29
	TTA0764DD	170	153	48	45	31	29
8.33	TTA1014DD	196	175	51	50	37	37
	TTA1014DC	214	193	57	57	39	40
10.4	TTA1264DD	227	206	61	63	41	41
13	TTA1564DD	363	317	87	88	71	71
	TTA1564DC	365	319	87	87	73	72
16.7	TTA2014DD	394	348	128	36	144	40
	TTA2014DC	398	352	100	100	76	76
20.9	TTA2514DC	457	411	117	118	88	88

Figure 11. TTA072, 090, 120, 150, TTA060, 076, 101

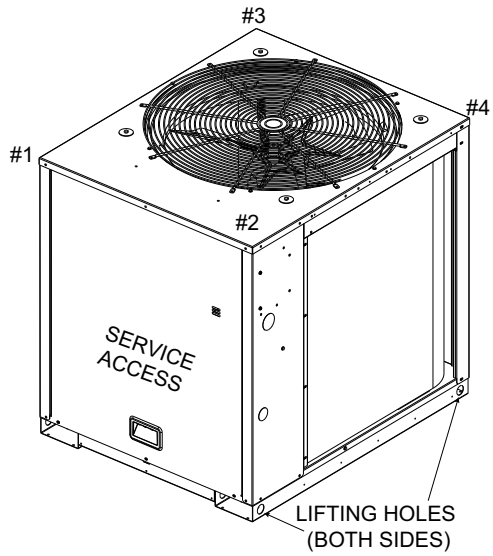
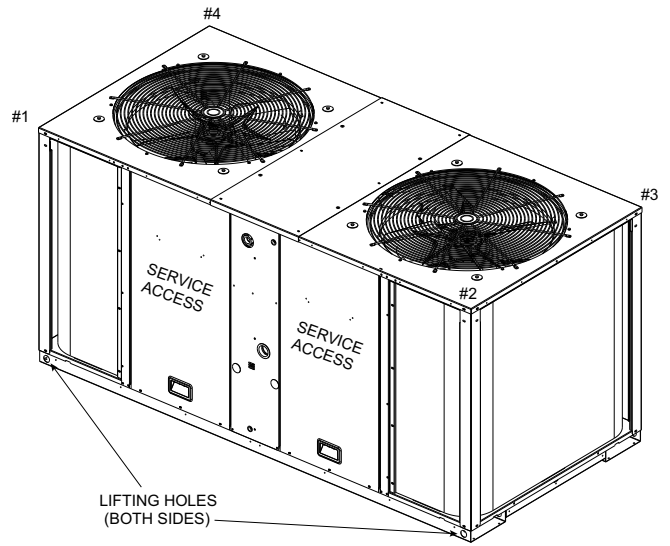

Figure 12. TTA180, 240, 300, TTA156, 201, 251



Installation

Refrigerant Piping Guidelines

Figure 13. Allowable elevation difference: TTA above indoor unit

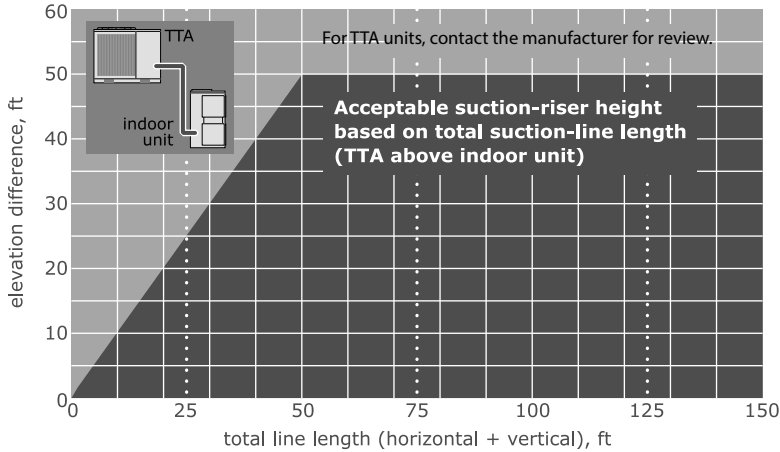

Figure 14. Piping example

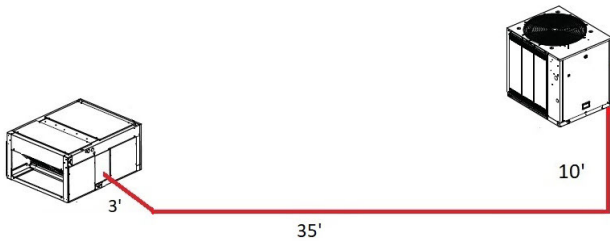
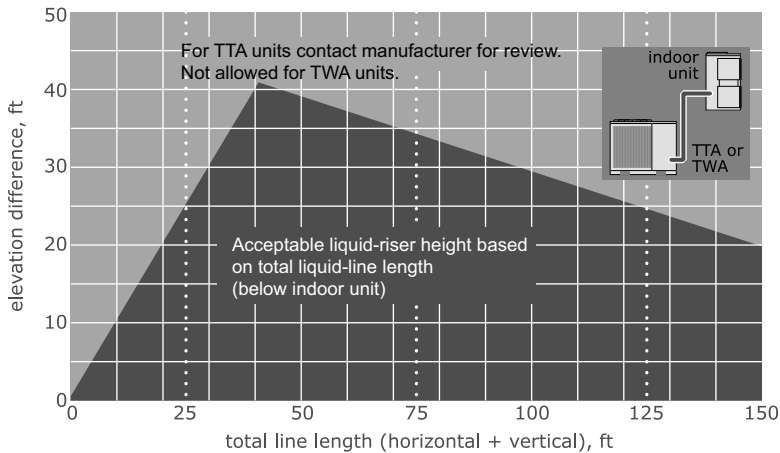

Figure 15. Allowable elevation difference: TTA or TWA below indoor unit



Important: Read Application Guide SS-APG008*-EN thoroughly before installing this unit.

Notes:

- Route refrigerant piping for minimum linear length, minimum number of bends and fittings.
- Complex examples may require the use of more than one table. For Figure 6, the liquid line rises 10 feet then drops, and then rises for another 10 feet. Liquid drops are ignored. This is a given of 20 foot of liquid lift. The suction rises 10 feet and then rises for another 10 feet. Suction drops are ignored. This is a given of 20 feet of suction lift. There is 126 feet of total line length. This example complies with both Figure 13, p. 20 for suction lines and Figure 15, p. 20 for liquid lines.

Figure 16. Piping Example

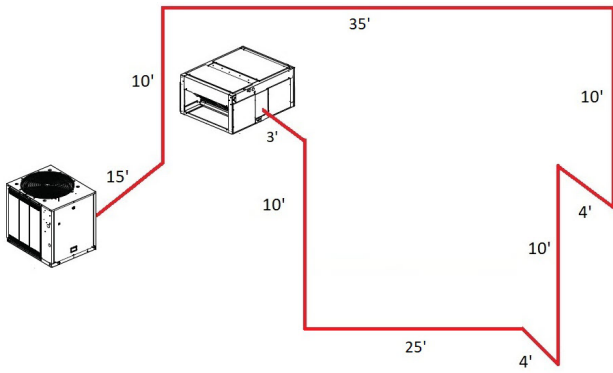

Refrigerant Piping Procedures (Outdoor Units)

⚠ WARNING

R-410A Refrigerant under Higher Pressure than R-22!

Failure to use proper equipment or components as described below, could result in equipment failing and possibly exploding, which could result in death, serious injury, or equipment damage.

The units described in this manual use R-410A refrigerant which operates at higher pressures than R-22. Use ONLY R-410A rated service equipment or components with these units. For specific handling concerns with R-410A, please contact your local Trane representative.

⚠ WARNING

Refrigerant under High Pressure!

Failure to follow instructions below could result in an explosion which could result in death or serious injury or equipment damage.

System contains refrigerant under high pressure. Recover refrigerant to relieve pressure before opening the system. See unit nameplate for refrigerant type. Do not use non-approved refrigerants, refrigerant substitutes, or refrigerant additives.

⚠ WARNING

Explosion Hazard!

Failure to follow instructions below could result in an explosion which could result in death or serious injury, and equipment damage.

NEVER bypass system safeties in order to pump down the unit component's refrigerant into the microchannel heat exchanger (MCHE) coil. Do NOT depress the compressor contactor since it effectively bypasses the high-pressure control.

Each unit ships with a holding charge of dry nitrogen. The nitrogen should be removed and the entire system evacuated (at the proper time) to avoid possible contamination.

1. Remove the compressor service access panel.
2. Locate the liquid and suction line access valves. Check that the piping connection stubs (Figure 17, p. 22) line up properly with the holes in the unit cabinet.

Figure 17. Outdoor units - refrigerant piping (with dry nitrogen)

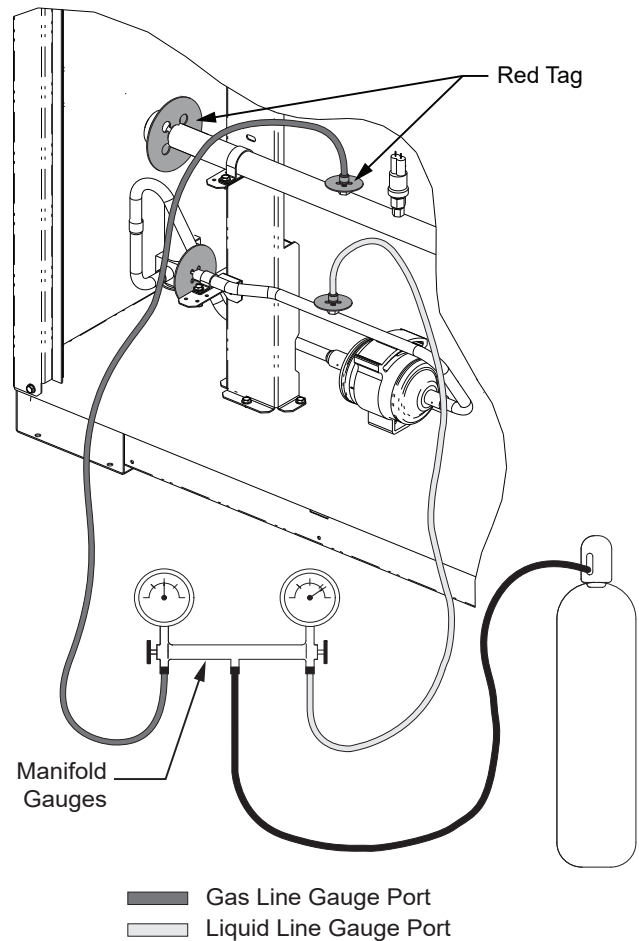

3. Install gauges to determine if the circuits are still pressurized. If not, the charge has escaped and should be repaired as required to obtain a leak-free circuit. If the circuits are still pressurized, use the gauges to slowly release the nitrogen charge to the atmosphere and remove both seal caps from the outdoor unit connection stubs.

NOTICE

System Component Damage!

Do not remove the seal caps from refrigerant connections until prepared to braze refrigerant lines to the connections. Excessive exposure to atmosphere (> 5 min.) may allow moisture or dirt to contaminate the system, damaging valve seals and causing ice formation in system components.

⚠ WARNING**Explosion Hazard and Deadly Gases!**

Failure to follow all proper safe refrigerant handling practices could result in death or serious injury. Never solder, braze or weld on refrigerant lines or any unit components that are above atmospheric pressure or where refrigerant may be present. Always remove refrigerant by following the guidelines established by the EPA Federal Clean Air Act or other state or local codes as appropriate. After refrigerant removal, use dry nitrogen to bring system back to atmospheric pressure before opening system for repairs. Mixtures of refrigerants and air under pressure may become combustible in the presence of an ignition source leading to an explosion. Excessive heat from soldering, brazing or welding with refrigerant vapors present can form highly toxic gases and extremely corrosive acids.

- Cut, fit and braze tubing, starting at the outdoor unit and work toward the indoor unit. See “Charging Levels,” p. 26.

Note: Use long radius ells for all 90° bends.

All brazing should be done using a 2 to 3 psig dry nitrogen purge flowing through the pipe being brazed, see Figure 17, p. 22.

NOTICE**System Component Damage!**

Install a regulating valve between the nitrogen source and the gauge manifold. Unregulated pressure can damage system components.

NOTICE**System Component Damage!**

Wet-wrap all valves and protect painted surfaces from excessive heat. Heat can damage system components and the unit finish.

- Shut off nitrogen supply. Shut off the manifold valve for the line that is connected to the suction line access valve. Disconnect the line from the access valve.

Refrigerant Piping Procedures (Indoor Unit)

Once liquid and suction lines are complete to the refrigerant connections on the indoor unit, remove the gauge port core(s) on the indoor unit connection stubs to release the dry nitrogen charge.

NOTICE**Unit Damage!**

Do not apply heat to remove seal caps until the gauge port cores have been removed. If seal caps are intact, application of heat may generate excessive pressure in the unit and result in damage to the coil or expansion valve.

- Remove both seal caps from the indoor unit connection stubs.

NOTICE**Unit Damage!**

Do not remove the seal caps from refrigerant connections until prepared to braze refrigerant lines to the connections. Due to the high hygroscopic properties of the R-410A oil, excessive exposure to atmosphere will allow moisture to contaminate the system, damaging the compressor.

- Turn on nitrogen supply. Nitrogen enters through the liquid line gauge port.
- Braze the liquid line connections.
- Open the gauge port on the suction line and then braze the suction line to the connection stub. Nitrogen will bleed out the open gauge port on the suction line.
- Shut off nitrogen supply.

Leak Check

⚠ WARNING**Explosion Hazard!**

Failure to follow these instructions could result in death or serious injury or equipment or property-only damage.

Use only dry nitrogen with a pressure regulator for pressurizing unit. Do not use acetylene, oxygen or compressed air or mixtures containing them for pressure testing. Do not use hydrogen mixtures containing refrigerant and air above atmospheric pressure for pressure testing as they may become flammable and could result in an explosion. Refrigerant, when used as a trace gas should only be mixed with dry nitrogen for pressurizing units.

⚠ WARNING**Explosion Hazard!**

Failure to follow safe leak test procedures below could result in death or serious injury or equipment or property-only-damage.

Never use an open flame to detect gas leaks. Use a leak test solution for leak testing.

After the brazing operation of refrigerant lines to both the outdoor and indoor unit is completed, the field brazed connections must be checked for leaks. Pressurize the

Installation

system through the gauge port with dry nitrogen to 200 psi. Use soap bubbles or other leak-checking methods to ensure that all field joints are leak free. If not, release pressure, repair and repeat leak test.

System Evacuation

1. After completion of leak check, evacuate the system.
2. Attach appropriate hoses from manifold gauge to gas and liquid line pressure taps.

Note: Unnecessary switching of hoses can be avoided and complete evacuation of all lines leading to sealed system can be accomplished with manifold center hose and connecting branch hose to a cylinder of R-410A and vacuum pump.

3. Attach center hose of manifold gauges to vacuum pump.

NOTICE

Operating Under Vacuum!

Failure to follow these instructions will result in compressor failure.

Do not operate or apply power to the compressor while under a vacuum.

4. Evacuate the system to hold a 500 micron vacuum.
5. Close off valve to vacuum pump and observe the micron gauge. If gauge pressure rises above 500 microns in one minute, then evacuation is incomplete or the system has a leak.
6. If vacuum gauge does not rise above 500 microns in 10 minutes, the evacuation should be complete.

NOTICE

Equipment Damage!

Charge with access port on the liquid line only.

7. With vacuum pump and micron gauge blanked off, open valve on refrigerant cylinder and allow refrigerant pressure to build up to about 80 psig.
8. Close valve on the refrigerant supply cylinder. Close valves on manifold gauge set and remove refrigerant charging hoses from liquid and gas gauge ports.
9. Leak test the entire system. Using proper procedures and caution, as described in the previous section, repair any leaks found and repeat the leak test.

Insulating and Isolating Refrigerant Lines

Insulate the entire suction line with refrigerant piping insulation. Also insulate any portion of the liquid line exposed to temperature extremes. Insulate and isolate liquid and suction lines from each other. Isolate refrigerant lines from the structure and any duct work.

Important:

1. To prevent possible noise or vibration problems, be certain to isolate refrigerant lines from the building.
2. All suction and hot gas bypass piping (if installed) should be insulated from the termination in the air handler to the condensing unit cabinet entry. Failure to do so can cause condensate drip off and performance degradation.
3. Prior to starting a unit, it is advisable to have the approved oils available in the event oil needs to be added to the system.
4. Refer to Application Guide SS-APG008*-EN for units needing additional oil and for oil amounts.

NOTICE

Equipment Damage!

This is POE oil, which readily absorbs moisture.

Always use new oil and never leave containers open to atmosphere while not in use.

Table 3. R-410A TTA approved oils

Unit Model Number	Approved Oils
TTA0604DA, TTA0604DD, TTA0724*A, TTA0724*D, TTA0764DD, TTA0904*D, TTA0764DA, TTA0904*A, TTA1014DC, TTA1014DD, TTA1204*C, TTA1204*D, TTA1264DD, TTA1504*D, TTA1564DD, TTA1804*D, TTA1564DC, TTA1804*C, TTA2014DD, TTA2404*D	Trane Oil Part Number OIL00094 (1 quart container)
TTA1014DA, TTA1204*A, TTA2014DC, TTA2404*C, TTA2514DC, TTA3004*C	Trane Oil Part Number OIL00079 (1 quart container) or OIL00080 (1 gallon container)

For units equipped with compressors containing sight glasses, the oil level must be visible through the sight glass when the compressor is running under stabilized conditions and a few minutes after the compressor has stopped.

Refrigerant Charging Procedure

If charging by weight, refer to “Charging Levels,” p. 26 for starting charge. If refrigerant adjustments are needed because of length of line, refer to the Charging Charts and Superheat values available on unit access panels.

Refer to Wiring Matrix and Device Location Matrix for list of charging charts and super heat tables available in e-Library. Charge by weight through the gauge port on the liquid line.

Notes:

- Refrigerant should only be charged in the liquid state.
- When possible, always charge the refrigerant into the liquid line of the unit.
- If the entire charge can't be charged into the liquid line, the balance of the unit charge can be metered through a charging manifold set as liquid — preferably through a schrader valve into the suction line to the compressor — only while the compressor is running.
- Check and adjust superheat using the superheat table, then re-check charging charts to determine if charge corrections are necessary. Refer to Charging Data for list of super heat tables available in e-Library.

NOTICE

Equipment Damage!

Never charge liquid refrigerant into the suction line of the unit with the compressor off.

Figure 18. Outdoor units - refrigerant piping

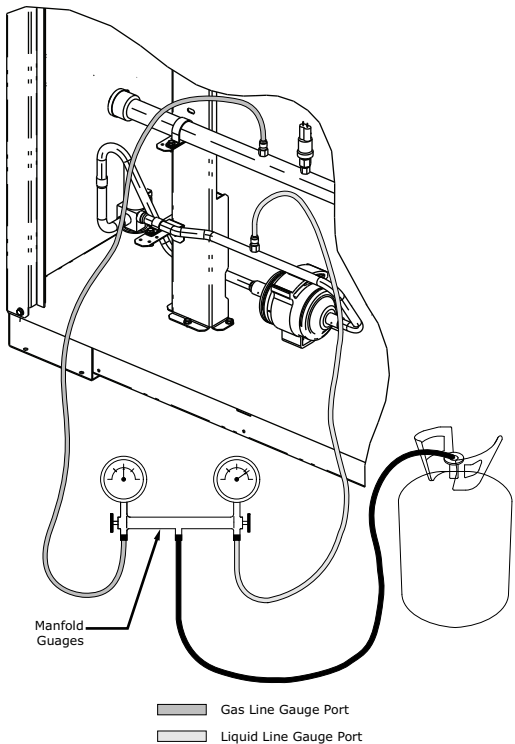

Installation

Charging Levels

Application Guide (SS-APG008*-EN) available through e-Library or your local sales office.

Important: For the correct line diameter, for line lengths greater than 25 feet, see the Odyssey

Table 4. Estimated charge levels at AHRI rated line lengths (25 feet) - 50 and 60 Hz

Matched Set	Refrigerant Charge (lbs)		Per Circuit	
	Circuit 1	Circuit 2	Liquid Line Diameter	Vapor Line Diameter
TTA0604DA w/ TWE0764DA	10.0	N/A	0.5 (1/2")	1.125 (1 1/8")
TTA0604DD w/ TWE0724DB	7.0	7.0	0.5 (1/2")	0.875 (7/8")
TTA0724*A w/ TWE0904*A	10.0	N/A	0.5 (1/2")	1.125 (1 1/8")
TTA0724*D w/ TWE0724*B	7.0	7.0	0.5 (1/2")	0.875 (7/8")
TTA0764DA w/ TWE0764DA	10.4	N/A	0.5 (1/2")	1.375 (1 3/8")
TTA0764DA w/ TWE1014DA	11.5	N/A	0.5 (1/2")	1.375 (1 3/8")
TTA0764DD w/ TWE0764DB	7.2	7.5	0.5 (1/2")	1.125 (1 1/8")
TTA0904*A w/ TWE0904*A	10.4	N/A	0.5 (1/2")	1.375 (1 3/8")
TTA0904*A w/ TWE1204*A	11.4	N/A	0.5 (1/2")	1.375 (1 3/8")
TTA0904*D w/ TWE0904*B	7.1	7.5	0.5 (1/2")	1.125 (1 1/8")
TTA1014DD w/ TWE1014DB	8.0	8.2	0.5 (1/2")	1.125 (1 1/8")
TTA1014DC w/ TWE1014DA	13.1	N/A	0.5 (1/2")	1.375 (1 3/8")
TTA1204*D w/ TWE1204*B	8.2	8.4	0.5 (1/2")	1.125 (1 1/8")
TTA1204*C w/ TWE1204*A	13.1	N/A	0.5 (1/2")	1.375 (1 3/8")
TTA1264DD w/ TWE1264DB	10.5	10.5	0.5 (1/2")	1.125 (1 1/8")
TTA1504*D w/ TWE1504*B	10.4	10.4	0.5 (1/2")	1.125 (1 1/8")
TTA1564DD w/ TWE1564DB	11.5	12.0	0.5 (1/2")	1.375 (1 3/8")
TTA1564DD w/ TWE2014DB	11.6	11.6	0.5 (1/2")	1.375 (1 3/8")
TTA1564DC w/ TWE1564DB	22.6	N/A	0.625 (5/8")	1.625 (1 5/8")
TTA1804*D w/ TWE1804*B	11.5	11.5	0.5 (1/2")	1.375 (1 3/8")
TTA1804*D w/ TWE2404*B	11.5	11.5	0.5 (1/2")	1.375 (1 3/8")
TTA1804*C w/ TWE1804*B	22.5	N/A	0.625 (5/8")	1.625 (1 5/8")
TTA2014DD w/ TWE2014DB	11.2	11.3	0.5 (1/2")	1.375 (1 3/8")
TTA2014DC w/ TWE2014DB	24.1	N/A	0.625 (5/8")	1.625 (1 5/8")
TTA2404*D w/ TWE2404*B	11.2	11.2	0.5 (1/2")	1.375 (1 3/8")
TTA2404*C w/ TWE2404*B	23.8	N/A	0.625 (5/8")	1.625 (1 5/8")
TTA2514DC w/ TWE2514DB	30.5	N/A	0.625 (5/8")	2.125 (2 1/8")
TTA3004*C w/ TWE3004*B	29.8	N/A	0.625 (5/8")	2.125 (2 1/8")

Notes:

1. For line lengths other than 25', please refer to the Application Guide (SS-APG008*-EN) for charge levels, oil addition and line sizes.
2. TTA0604DA and TTA0724*A need a reducer for vapor line. (1.375 to 1.125 inch) (1 3/8" to 1 1/8").
3. TTA2514DC and TTA3004*C are provided with a transition tube to be installed outside of the unit for front or rear access, (1.625 to 2.125 inch) (1 5/8" to 2 1/8"). See Refrigerant Charging Procedure for transition tube location and electrical connections.

Liquid Charging

This procedure is accomplished with the unit operating. Electrical connections must be complete. Do not proceed until the system is ready to operate.

Note: *The compressor access panel must be installed when the unit is running and being charged. Manifold hoses must be routed through refrigerant gauge access hole(s). See "Dimensional Data," p. 9 for specific locations.*

⚠ WARNING

Live Electrical Components!

Failure to follow all electrical safety precautions when exposed to live electrical components could result in death or serious injury.

When it is necessary to work with live electrical components, have a qualified licensed electrician or other individual who has been properly trained in handling live electrical components perform these tasks.

1. Turn on power to the unit. Allow the system to run for 15 minutes to stabilize operating conditions.
2. Measure airflow across the indoor coil. Compare the measurements with the fan performance data in the Data/Submittal. Once proper airflow is established, compare discharge pressure and liquid temperature to the charging charts. Add or remove refrigerant (liquid only) as required to obtain correct discharge pressure and liquid temperature.
3. Check suction line superheat and condenser sub-cooling to ensure the unit is operating properly.
4. Disconnect all power to the unit.

Important: *If the unit is charged and left without power until a later date, the crankcase heater should be energized for a minimum of 8 hours prior to powering the compressor(s).*

⚠ WARNING

Hazardous Voltage w/Capacitors!

Failure to disconnect power and discharge capacitors before servicing could result in death or serious injury.

Disconnect all electric power, including remote disconnects and discharge all motor start/run capacitors before servicing. Follow proper lockout/tagout procedures to ensure the power cannot be inadvertently energized. For variable frequency drives or other energy storing components provided by Trane or others, refer to the appropriate manufacturer's literature for allowable waiting periods for discharge of capacitors. Verify with a CAT III or IV voltmeter rated per NFPA 70E that all capacitors have discharged.

5. Remove the charging system from the unit.
6. Replace all panels.

Electrical Wiring

⚠ WARNING

Proper Field Wiring and Grounding Required!

Failure to follow code could result in death or serious injury.

All field wiring **MUST** be performed by qualified personnel. Improperly installed and grounded field wiring poses **FIRE** and **ELECTROCUTION** hazards. To avoid these hazards, you **MUST** follow requirements for field wiring installation and grounding as described in NEC and your local/state/national electrical codes.

Field wiring consists of providing power supply to the unit, installing the system indoor thermostat or zone sensor and providing low voltage system interconnecting wiring. Access to electrical connection locations is shown in "Dimensional Data," p. 9. Determine proper wire sizes and unit protective fusing requirements by referring to the unit nameplate. Field wiring diagrams for accessories are shipped with the accessory.

Unit Power Supply

The installer must provide line voltage circuit(s) to the unit main power terminals as shown by the unit wiring diagrams. Adhesive backed diagrams are affixed inside the control box cover panel. Wiring diagrams are also available through e-Library or by contacting a local sales office. Power supply must include a disconnect switch in a location convenient to the unit. Ground the unit according to local codes and provide flexible conduit if codes require and/or if vibration transmission may cause noise problems.

Important: All wiring must comply with applicable local and national (NEC) codes. Type and location of disconnect switches must comply with all applicable codes.

⚠ WARNING

Proper Field Wiring and Grounding Required!

Failure to follow code could result in death or serious injury.

All field wiring MUST be performed by qualified personnel. Improperly installed and grounded field wiring poses FIRE and ELECTROCUTION hazards. To avoid these hazards, you MUST follow requirements for field wiring installation and grounding as described in NEC and your local/state/national electrical codes.

NOTICE

Use Copper Conductors Only!

Failure to use copper conductors could result in equipment damage as the equipment was not designed or qualified to accept other types of conductors.

Low Voltage Wiring

Mount the indoor thermostat, zone sensor, or programmable zone sensor in accordance with the corresponding thermostat installation instructions. Install color-coded, weather-proof, multi-wire cable according to the field wiring instructions (see "Field Wiring," p. 30).

Note: Refer to thermostat or zone sensor wire installation guide for proper wire gauge.

Symbio™ Controls

Wiring shown with dashed lines is to be furnished and installed by the customer. All customer supplied wiring must be copper only and must conform to NEC and local electrical codes. Codes may require line of sight between disconnect switch and unit.

Figure 19. Symbio™ jobsite connections

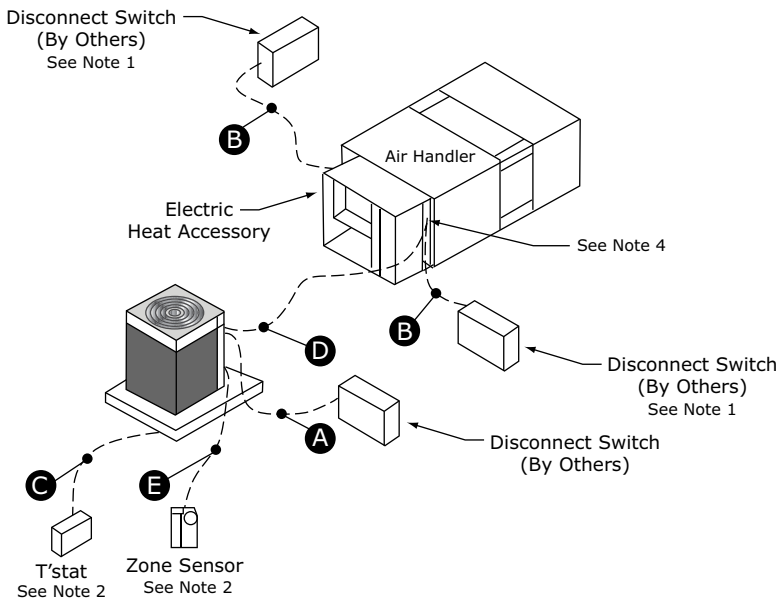

Power Wires

- A. 3 wires, line voltage for 3 phase, 1 grounding wire**
- B. 3 wires, line voltage for 3 phase, (2 wires for single phase) 1 grounding wire**

Control Wires

- C. Cooling only (or Cooling with Heat) thermostat: 4 to 7 wires depending on stages of cooling and electric heat
- D. Wiring between indoor and outdoor unit: 5 to 11 wires depending on unit control options*
- E. Zone Sensor: 4 to 7 wires depending on zone sensor model*

Communication signal wires require shielded twisted pairs.

Use factory-supplied 165 ft. length of Comlink cable with a PVC jacket, 18/1 PR, stranded shield, 25 PF/FT plenum rated for the field communication signal wiring. Refer to wiring diagram schematics for identification of shielded twisted pairs.

Notes:

1. When electric heater accessory is used, single point power entry or dual point power entry is field optional. Single point power entry option is through electric heater only.
2. *Choose only one of the following; Thermostat, Mechanical Zone Sensor, Programmable Zone Sensor Panel or BAS Zone Sensor.
3. **

⚠ WARNING

Electrical Shock Hazard!
 Failure to follow instructions below could result in death or serious injury.
 Properly connect the system's oversized protective earthing (grounding) terminal(s).

4. Once power wire connections are complete inside the air handler control box, seal the sheet metal entry points of the control box by using parts (neoprene gasket, grommet, and plug) shipped along with the air handler unit package.

Installation

Important: For the EDC switch to be functional and thereby facilitate reliable unit operation, make the EDC connections from the indoor to the outdoor control boxes.

Table 5. Recommended thermostat wire size

Wire Size (Gauge)	Maximum Wire Length Physical distance between Unit & T'stat
22	30 Feet
20	50 Feet
18	75 Feet
16	125 Feet
14	200 Feet

Table 6. Zone sensor module wiring

Distance from Unit to Control	Recommended Wire Size
0-150 feet (0-45.7 m)	22 gauge (0.33 mm ²)
151-240 feet (46-73.1 m)	20 gauge (0.50 mm ²)
241-305 feet (73.5-117.3 m)	18 gauge (0.75 mm ²)
386-610 feet (117.7-185.9 m)	16 gauge (1.31 mm ²)
611-970 feet (186.2-295.7 m)	14 gauge (2.08 mm ²)

Field Wiring

Refer to the latest version of Condenser and Air Handler Pairing guide (SS-SVN016*-EN) for instructions on field wiring connections.

Refrigerant Circuit

Figure 20. Typical split system cooling refrigerant circuit — microchannel

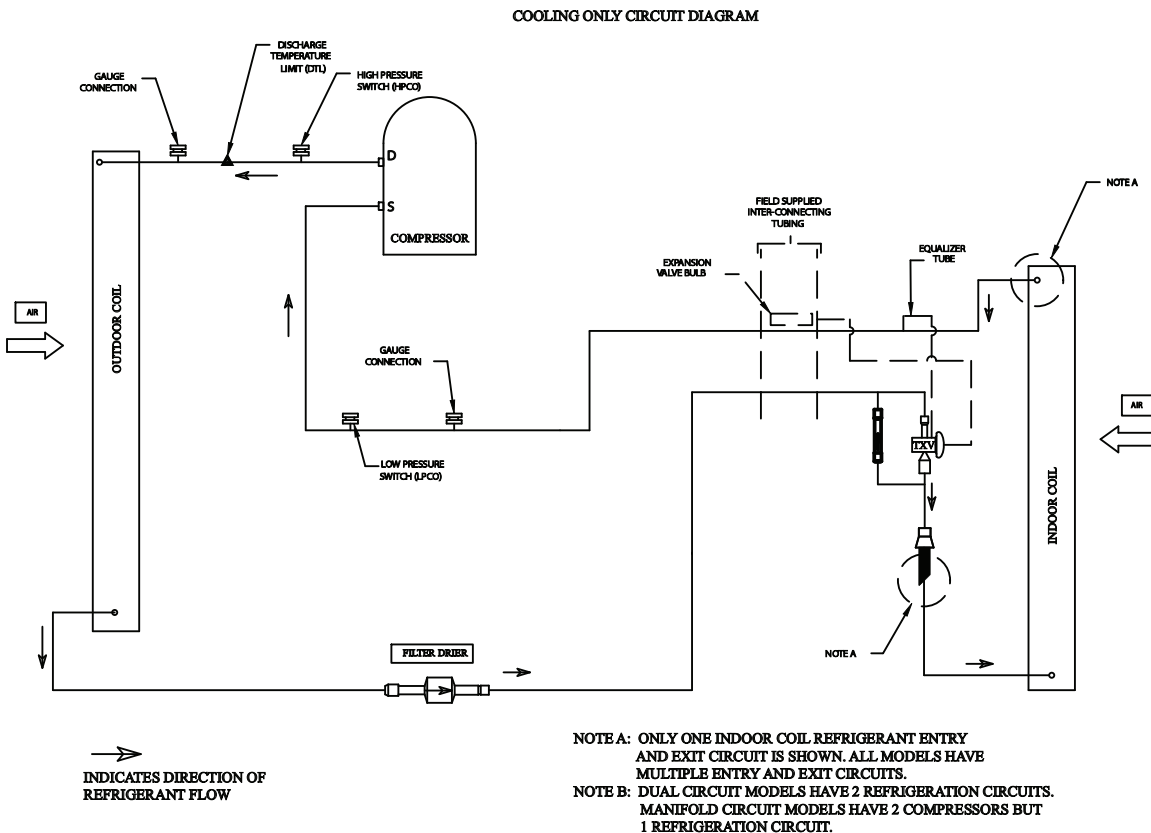

Pre-Start

Control Circuit Features

Note: *Not all of these features may be required for your unit, check electrical schematic.*

Discharge Temperature Limit (DTL)

The control's sensor is located on the discharge line. This device will shut off the compressor and the outdoor fan(s) if the discharge temperature exceeds the DTL setting. Once the discharge temperature has returned to normal, the compressor will cycle back on.

Low Outdoor Ambient Cooling

All Odyssey units with Symbio™ 700 controls have cooling capabilities down to 0°F as standard. At temperatures below 55°F for single compressor units and 40°F for dual compressor units, some reduction in cooling capacity can be expected. At this temperature, equipment can provide approximately 60 percent of the mechanical cooling capacity. When the optional Low Ambient Accessory kit is field installed, the full capacity of the unit is available down to 0°F.

Evaporator Defrost Control (EDC)

This control is located in the Air Handler. The control's sensing tube is embedded vertically in the evaporator coil, near the center. This device will stop the compressor if the indoor coil temperature drops below its setting. The indoor air will still circulate across the coil bringing the temperature of the coil back up to the cut-in temperature of the evaporator defrost control.

Low Pressure Cut-Out (LPC)

This control's sensor is located in the suction (gas) line, near the compressor. This control will stop the compressor and the outdoor fans if suction pressure drops below the Low Pressure Cut-Out setting. Once the suction pressure has returned to normal, the compressor and outdoor fans will cycle back on.

High Pressure Cut-Out (HPCO)

This control's sensor is located in the discharge line. This device will shut off the compressor and the outdoor fan(s) if the discharge pressure exceeds the High Pressure Cut-Out's setting. Once the discharge pressure has returned to normal, the compressor will cycle back on.

⚠ WARNING

Prevent Injury!

Due to agency safety requirements, no schrader core is to be installed beneath the HPCO. Removal of the HPCO without evacuating the system charge could cause injury and release of refrigerant.

Internal Overload Protector (IOL)

This device is embedded in the compressor. It will shut off the compressor if the discharge temperature of the compressor exceeds its design trip temperature.

Note: *The IOL will put the compressor back in operation once the compressor motor heat has dropped below the trip setting; however, a check of the refrigerant and electrical systems should be made to determine the cause and be corrected.*

Troubleshooting

⚠ WARNING

Live Electrical Components!

Failure to follow all electrical safety precautions when exposed to live electrical components could result in death or serious injury.

When it is necessary to work with live electrical components, have a qualified licensed electrician or other individual who has been properly trained in handling live electrical components perform these tasks.

Refer to the latest version of the Symbio™ 700 Controller with Odyssey Split Systems Applications Guide (ACC-APG001*-EN) for details on troubleshooting the control system.

Service Test Mode

The Symbio™ 700 supports a Service Test Mode that can be used to energize the various components of the system, either to support general system startup tasks or to support troubleshooting. The user can initiate Service Test Mode through the controller user interfaces, including the Symbio Service and Installation mobile application.

The modes shown below can be initiated. Depending on the equipment configuration, the controller will energize the

appropriate outputs. A user-selected timeout value will determine how long the controller will remain in any given state once initiated. For detailed information on how each Service Test State is interpreted based on the equipment's configuration, refer to the Symbio™ 700 Controller with Odyssey Split Systems Applications Guide (ACC-APG001*-EN).

Figure 21. Symbio 700 service test mode

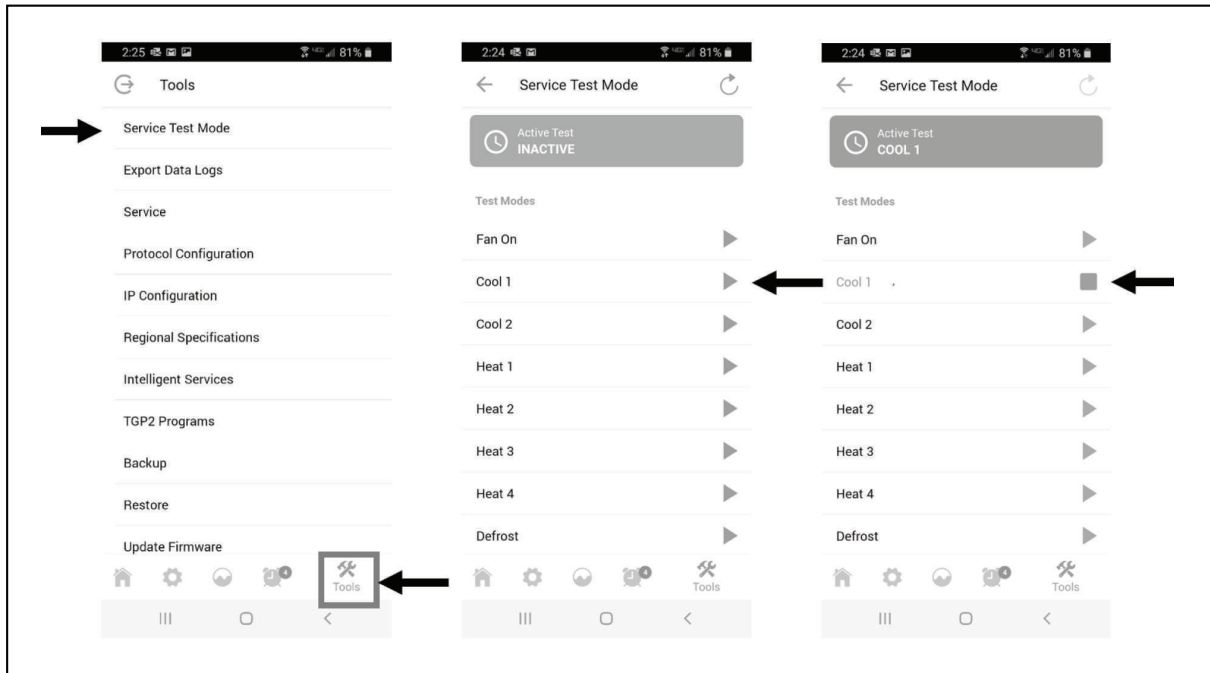

Maintenance

⚠ WARNING

Hazardous Voltage w/Capacitors!

Failure to disconnect power and discharge capacitors before servicing could result in death or serious injury.

Disconnect all electric power, including remote disconnects and discharge all motor start/run capacitors before servicing. Follow proper lockout/tagout procedures to ensure the power cannot be inadvertently energized. For variable frequency drives or other energy storing components provided by Trane or others, refer to the appropriate manufacturer's literature for allowable waiting periods for discharge of capacitors. Verify with a CAT III or IV voltmeter rated per NFPA 70E that all capacitors have discharged.

NOTICE

Operating Under Vacuum!

Failure to follow these instructions will result in compressor failure.

Do not operate or apply power to the compressor while under a vacuum.

Perform all of the indicated maintenance procedures at the intervals scheduled. This will prolong the life of the unit and reduce the possibility of costly equipment failure.

Monthly

Conduct the following maintenance inspections once per month.

- Check unit wiring to ensure all connections are tight and that the wiring insulation is intact.
- Inspect the condenser coils for dirt and debris. If the coils appear dirty, clean them.
- With the unit operating in the cooling mode, check the suction and discharge pressures and compare them with Pressure Curve values. Record these readings on the ["Maintenance Log," p. 35.](#)

Annually (Cooling Season)

The following maintenance procedures must be performed at the beginning of each cooling season to ensure efficient unit operation.

- Perform all of the monthly maintenance inspections.
- With the unit operating, check unit superheat and record the reading in the ["Maintenance Log," p. 35.](#)
- Remove any accumulation of dust and/or dirt from the unit casing.
- Remove corrosion from any surface and repaint. Check the gasket around the control panel door to ensure it

fits correctly and is in good condition to prevent water leakage.

- Inspect the control panel wiring to ensure that all connections are tight and that the insulation is intact.

Note: *Condenser fan motors are permanently lubricated.*

- Check refrigerant piping and fittings for leaks
- Inspect the condenser coils for dirt and debris. If the coils appear dirty, clean them.

Coil Cleaning

Regular coil maintenance, including annual cleaning—enhances the unit's operating efficiency by minimizing:

- compressor head pressure and amperage draw
- water carryover
- fan brake horsepower
- static pressure losses

At least once each year — or more often if the unit is located in a **dirty** environment — clean the coil using the instructions outlined below. Be sure to follow these instructions as closely as possible to avoid damaging the coils.

Microchannel (MCHE) Coils

NOTICE

Coil Damage!

Failure to follow instructions below could result in coil damage.

DO NOT use any detergents with microchannel condenser coils.

Use pressurized water or air ONLY, with pressure no greater than 600psi.

For additional information regarding the proper microchannel coil cleaning procedure, refer to RT-SVB83*-EN

Due to the soft material and thin walls of the MCHE coils, the traditional field maintenance method recommended for Round Tube Plate Fin (RTPF) coils does not apply to microchannel coils. Moreover, chemical cleaners are a risk factor to MCHE due to the material of the coil. The manufacturer does not recommend the use of chemical cleaners to clean microchannel coils. Using chemical cleaners could lead to warranty claims being further evaluated for validity and failure analysis.

The recommended cleaning method for microchannel condenser coils is pressurized water or air with a non-pinpoint nozzle and an ECU of at least 180 with pressure no greater than 600 psi. To minimize the risk of coil damage, approach the cleaning of the coil with the pressure washer aimed perpendicular to the face of the coil during cleaning. Optimum clearance between the sprayer nozzle and the microchannel coil is 1-inch to 3-inch.

Charging Data and Pressure Curves

Table 7. TTA Charging data and pressure curves

Condenser	Air Handler	Refrigerant Charging Curve Superheat and Charge Table	Pressure Curves
TTA0604DA*	TWE0764DA*	436759020001	436759020001
TTA0724*A*	TWE0904*A*	436759030001	436759030001
TTA0604DD*	TWE0724DB*	436759040001	436759530001
TTA0724*D*	TWE0724*B*	436759050001	436759540001
TTA0764DA*	TWE0764DA*	436765800001	436765800001
TTA0764DA*	TWE1014DA*	436760750001	436760750001
TTA0904*A*	TWE0904*A*	436765810001	436765810001
TTA0904*A*	TWE1204*A*	436759750001	436759750001
TTA0764DD*	TWE0764DB*	436765820001	436766300001
TTA0904*D*	TWE0904*B*	436765830001	436766240001
TTA1014DA*	TWE1014DA*	436759100001	436759100001
TTA1204*A*	TWE1204*A*	436759110001	436759110001
TTA1014DC*	TWE1014DA*	436759120001	436759120001
TTA1204*C*	TWE1204*A*	436759130001	436759130001
TTA1014DD	TWE1014DB*	436759140001	436759570001
TTA1204*D	TWE1204*B	436759150001	436759580001
TTA1804*D*	TWE1804*B*	436765910001	436765910001
TTA1804*D*	TWE2404*B*	436759740001	436759740001
TTA1564DC*	TWE1564DB*	436765920001	436765920001
TTA1804*C*	TWE1804*B*	436765930001	436765930001
TTA2014DD*	TWE2014DB*	436759220001	436759220001
TTA2404*D*	TWE2404*B*	436759230001	436759230001
TTA2014DC*	TWE2014DB*	436759240001	436759240001
TTA2404*C*	TWE2404*B*	436759250001	436759250001
TTA2514DC*	TWE2514DB*	436759260001	436759260001
TTA3004*C*	TWE3004*B*	436759270001	436759270001

Wiring Diagram Matrix and Device Location

Table 8. TTA wiring diagrams

Part Number	Description	Applicability
1213-4177	Power Schematic (Wiring Diagram) for units with Dual Compressors and Dual Fans	All Units with Digit 4-6 = 156/180/201/240/251/300
1213-4178	Power Schematic (Wiring Diagram) for units with Dual Compressors and Single Fans	All Units with Digit 4-6 = 060/072/076/090/101/120/126/150 AND Digit 9 = "C" or "D"
1213-4176	Power Schematic (Wiring Diagram) for units with Single Compressors and Single Fan	All Units with Digit 4-6 = 060/072/076/090/120 and Digit 9 = "A"
1213-4267	Control Schematic (Wiring Diagram) for units with Single compressor and Single Fan	All TTA Units with Digit 4-6 = 060/072/090/120 and Digit 9 = "A"
1213-4268	Control Schematic (Wiring Diagram) for units with Dual compressor and Single Fan	All TTA Units with Digit 4-6 = 060/072/090/120/150 AND Digit 9 = "D" Digit 4-6 = 101/120 and Digit 9 = "C"
1213-4269	Control Schematic (Wiring Diagram) for units with Dual compressor and Dual Fans	All TTA Units with Digit 4-6 = 156/180/240/300 AND Digit 9 = "C" or "D" Digit 4-6 = 201/251 and Digit 9 = "C"
1213-4179	Control Schematic (Wiring Diagram) for units with Single Compressor (Unloading) and Single Fan	All TTA Units with Digit 4-6 = 076/090 and Digit 9 = "A"
1213-4180	Control Schematic (Wiring Diagram) for units with Dual compressor (Unloading) and Single Fan	All TTA Units with Digit 4-6 = 076/090/101/120/126/150 Digit 9 = "D"
1213-4181	Control Schematic (Wiring Diagram) for units with Dual compressor (Unloading) and Dual Fans	All TTA Units with Digit 4-6 = 201/240 Digit 9 = "D"

Table 9. TTA device location

Part Number	Description	Applicability
1213-3583	Device Location Print	All TTA Units with Digit 4-6 = 060/072/076/090/101/120/126/150
1213-3584	Device Location Print	All TTA Units with Digit 4-6 = 156/180/201/240/251/300

Warranty

For Commercial Unitary Equipment Rated 25 Tons and Under and Related Accessories

Products Covered — This warranty is extended by Trane, and applies to the following products:

- All packaged and split system air conditioners and heat pumps have a rated capacity of 25 tons and under.
- All packaged combinations gas/electric air conditioners having a rated capacity of 25 tons and under.
- All packaged combination gas/electric air conditioners having a rated capacity of 1.5 through 5 tons single phase electric power and used for commercial applications. (As used in this warranty, a commercial application is any application where the end purchaser uses the product for other than personal, family or household purposes.)
- All accessories for the above products which are sold by Trane and applied in accordance with Trane specifications.

Basic Warranty

The warrantor warrants for a period of twelve (12) months from the initial start-up or eighteen (18) months from date of shipment, whichever is sooner, that the products covered by this warranty (1) are free from defects in material and manufacture, and (2) have the capacities and ratings set forth in the warrantor's catalogs and bulletins. If any part of your air conditioner fails because of a manufacturing defect, Warrantor will furnish without charge the required replacement part.

If the heat exchanger fails because of a manufacturing defect within five years from the date of start-up, Warrantor will furnish without charge a replacement heat exchanger. In addition, if the optional, factory installed, stainless steel heat exchanger fails because of a manufacturing defect within ten years from the date of start-up, Warrantor will furnish without charge a replacement heat exchanger.

Any local transportation, related service labor and diagnosis calls are not included. In addition, if the sealed motor-compressor fails because of a manufacturing defect within the second through fifth year from the date of original purchase, Warrantor will furnish without charge the required replacement compressor.

Exclusions and Limitations

The warrantor's obligations and liabilities under this warranty are limited to furnishing F.O.B. factory or

warehouse at the warrantor-designated shipping point, freight allowed to Buyer's city (or port of export for shipments outside the conterminous United States) a replacement product or, at the option of the warrantor, parts for the repair of the product not conforming to this warranty and which have been returned to the warrantor.

The warrantor's warranty is conditional on the Customer providing written notice to the warrantor within thirty (30) days of the discovery of the defect. No product shall be returned to the warrantor without the warrantor's written permission. No liability whatever shall attach to warrantor until said products have been fully paid for and then said liability shall be limited to the purchase price of the equipment shown to be defective.

The warranty does not apply to any compressor or gas-fired heat exchanger which has been repaired or altered in such manner as, in the judgement of the warrantor, affects its stability or reliability. This warranty does not cover (1) any heat exchanger which has been fired with an improper type of fuel (2) a heat exchanger which is installed in a beauty parlor, dry cleaning establishment, de-greasing plant or in any corrosive atmosphere; or (3) any heat exchanger which is not shown to be defective by the warrantor's inspection.

This warranty does not cover damage due to accident, abuse, improper use, external causes, freezing, corrosion, erosion or deterioration. Local transportation, related service labor, air filters, diagnosis calls, refrigerant and related items are not covered.

THE WARRANTY AND LIABILITY SET FORTH HEREIN ARE IN LIEU OF ALL OTHER WARRANTIES AND LIABILITIES, WHETHER IN CONTRACT OR IN NEGLIGENCE, EXPRESS OR IMPLIED, IN LAW OR IN FACT, INCLUDING IMPLIED WARRANTIES OR MERCHANTABILITY AND FITNESS FOR A PARTICULAR PURPOSE AND ANY IMPLIED WARRANTIES OTHERWISE ARISING FROM THE COURSE OF DEALING OR TRADE. IN NO EVENT SHALL THE WARRANTOR BE LIABLE FOR ANY INCIDENTAL OR CONSEQUENTIAL DAMAGES.

The warrantor makes certain further warranty protection available on an optional, extra-cost basis. Any further warranty must be in writing. If you wish further help or information concerning this warranty, contact: Trane — Warrantor, 2701 Wilma Rudolph Blvd., Clarksville, TN 37040

Trane and American Standard create comfortable, energy efficient indoor environments for commercial and residential applications. For more information, please visit trane.com or americanstandardair.com.

Trane and American Standard have a policy of continuous product and product data improvement and reserve the right to change design and specifications without notice. We are committed to using environmentally conscious print practices.

SS-SVX001E-EN 12 Jan 2025
Supersedes SS-SVX001D-EN (March 2022)

©2025