



# Installation, Operation, and Maintenance

## **Solid State Starter Conversion**

### RTHA, RTHB, RTHC, RTHD



**Model Numbers:** RTHA, RTHB, RTHC, RTHD

**This document applies to service offering applications only.**

**This manual covers both Benschaw MX and MX2 solid state starters.**

MX starter used for units manufactured until November 2010.

MX2 starter used in units manufactured December 2010 and later.

#### **⚠ SAFETY WARNING**

**Only qualified personnel should install and service the equipment. The installation, starting up, and servicing of heating, ventilating, and air-conditioning equipment can be hazardous and requires specific knowledge and training. Improperly installed, adjusted or altered equipment by an unqualified person could result in death or serious injury. When working on the equipment, observe all precautions in the literature and on the tags, stickers, and labels that are attached to the equipment.**



# Introduction

Read this manual thoroughly before operating or servicing this unit.

## Warnings, Cautions, and Notices

Safety advisories appear throughout this manual as required. Your personal safety and the proper operation of this machine depend upon the strict observance of these precautions.

The three types of advisories are defined as follows:

- ⚠ WARNING** Indicates a potentially hazardous situation which, if not avoided, could result in death or serious injury.
- ⚠ CAUTION** Indicates a potentially hazardous situation which, if not avoided, could result in minor or moderate injury. It could also be used to alert against unsafe practices.
- NOTICE** Indicates a situation that could result in equipment or property-damage only accidents.

## Important Environmental Concerns

Scientific research has shown that certain man-made chemicals can affect the earth's naturally occurring stratospheric ozone layer when released to the atmosphere. In particular, several of the identified chemicals that may affect the ozone layer are refrigerants that contain Chlorine, Fluorine and Carbon (CFCs) and those containing Hydrogen, Chlorine, Fluorine and Carbon (HCFCs). Not all refrigerants containing these compounds have the same potential impact to the environment. Trane advocates the responsible handling of all refrigerants.

## Important Responsible Refrigerant Practices

Trane believes that responsible refrigerant practices are important to the environment, our customers, and the air conditioning industry. All technicians who handle refrigerants must be certified according to local rules. For the USA, the Federal Clean Air Act (Section 608) sets forth the requirements for handling, reclaiming, recovering and recycling of certain refrigerants and the equipment that is used in these service procedures. In addition, some states or municipalities may have additional requirements that must also be adhered to for responsible management of refrigerants. Know the applicable laws and follow them.

**⚠ WARNING**

**Proper Field Wiring and Grounding Required!**

Failure to follow code could result in death or serious injury. All field wiring **MUST** be performed by qualified personnel. Improperly installed and grounded field wiring poses **FIRE** and **ELECTROCUTION** hazards. To avoid these hazards, you **MUST** follow requirements for field wiring installation and grounding as described in **NEC** and your local/state/national electrical codes.

**⚠ WARNING**

**Personal Protective Equipment (PPE) Required!**

Failure to wear proper PPE for the job being undertaken could result in death or serious injury. Technicians, in order to protect themselves from potential electrical, mechanical, and chemical hazards, **MUST** follow precautions in this manual and on the tags, stickers, and labels, as well as the instructions below:

- Before installing/servicing this unit, technicians **MUST** put on all PPE required for the work being undertaken (Examples; cut resistant gloves/sleeves, butyl gloves, safety glasses, hard hat/bump cap, fall protection, electrical PPE and arc flash clothing). **ALWAYS** refer to appropriate Safety Data Sheets (SDS) and OSHA guidelines for proper PPE.
- When working with or around hazardous chemicals, **ALWAYS** refer to the appropriate SDS and OSHA/GHS (Global Harmonized System of Classification and Labeling of Chemicals) guidelines for information on allowable personal exposure levels, proper respiratory protection and handling instructions.
- If there is a risk of energized electrical contact, arc, or flash, technicians **MUST** put on all PPE in accordance with OSHA, NFPA 70E, or other country-specific requirements for arc flash protection, **PRIOR** to servicing the unit. **NEVER PERFORM ANY SWITCHING, DISCONNECTING, OR VOLTAGE TESTING WITHOUT PROPER ELECTRICAL PPE AND ARC FLASH CLOTHING. ENSURE ELECTRICAL METERS AND EQUIPMENT ARE PROPERLY RATED FOR INTENDED VOLTAGE.**

**⚠ WARNING****Follow EHS Policies!**

Failure to follow instructions below could result in death or serious injury.

- All Trane personnel must follow the company's Environmental, Health and Safety (EHS) policies when performing work such as hot work, electrical, fall protection, lockout/tagout, refrigerant handling, etc. Where local regulations are more stringent than these policies, those regulations supersede these policies.
- Non-Trane personnel should always follow local regulations.

**⚠ WARNING****Hazardous Voltage w/Capacitors!**

Failure to follow instructions below could result in death or serious injury.

Disconnect all electric power, including remote disconnects and discharge all motor start/run capacitors before servicing. Follow proper lockout/tagout procedures to ensure the power cannot be inadvertently energized. For variable frequency drives or other energy storing components provided by Trane or others, refer to the appropriate manufacturer's literature for allowable waiting periods for discharge of capacitors.

If this equipment is interlocked with other equipment, 115 volt AC may be present in the cabinet even though the main power is disconnected. Interlock signals must be deactivated by qualified personnel prior to any work in the cabinet.

Verify with an appropriate voltmeter that all capacitors have discharged, and interlock signals have been deactivated from all circuits.

**⚠ WARNING****Compressor Damage!**

Disconnect all electric power including remote disconnects prior to evacuating refrigeration. System power shall not be applied to the chiller while the refrigerant system is in a vacuum. Failure to disconnect power prior to evaluating the refrigerant system, or application of power while the refrigerant system is in a vacuum could cause compressor motor damage due to the nature of the solid state starter.

## Copyright

This document and the information in it are the property of Trane, and may not be used or reproduced in whole or in part without written permission. Trane reserves the right to revise this publication at any time, and to make changes to its content without obligation to notify any person of such revision or change.

## Trademarks

All trademarks referenced in this document are the trademarks of their respective owners.

## Revision History

Document updated to reflect Service Offering number.



# Table of Contents

General Information .....	5	Troubleshooting .....	42
General .....	5	Parts Ordering .....	43
Identify Existing Solid State Starter .....	5	Selecting New Starter .....	43
Removal of Existing Starter .....	6	Mounting Dimensions .....	44
Installation of Benshaw Starter .....	6	Starter Power Leads .....	47
Additional Components .....	6	Circuit Breaker with Shunt Trip .....	47
Wiring .....	7	Additional Components .....	47
RTHA Units with Wye-Delta Starters .....	8	Service Components .....	47
Removal of Existing Starter .....	8	Production Change .....	47
Installation of Benshaw Starter .....	9	Questions .....	47
Additional Components .....	10		
Wiring .....	10		
RTHB Units with A515 (or Wye-Delta) Starters	14		
Removal of Existing Starter .....	14		
Installation of Benshaw Starter .....	15		
Additional Components .....	16		
All Components Installed .....	16		
Wiring .....	16		
RTHC Units with EasySTART (or Wye-Delta) Starter	20		
Removal of Existing Starter .....	20		
Installation of Benshaw Starter .....	21		
Additional Components .....	22		
Wiring .....	22		
RTHC Units with IT (or Wye-Delta) Starter ..	26		
Removal of Existing Starter .....	26		
Installation of Benshaw Starter .....	27		
Additional Components .....	28		
Wiring .....	28		
RTHD Units with IT Starter .....	32		
Removal of Existing Starter .....	32		
Installation of Benshaw Starter .....	33		
All Components Installed .....	34		
Additional Components .....	34		
Wiring .....	34		
Quick Start, Initial Parameters .....	38		
Prior to Unit Power Up .....	38		
Remote Keypad .....	41		





# General Information

## General

### NOTICE

#### Compressor Motor Damage!

Disconnect all electric power including remote disconnects prior to evacuating refrigerant. System power shall not be applied to the chiller while the refrigerant system is in a vacuum. Failure to disconnect power prior to evacuating the refrigerant system, or application of power while the refrigerant system is in a vacuum, will cause compressor motor damage due to the nature of the solid state starter.

**Important:** Do NOT energize the unit if the refrigerant side of the system is in a vacuum.

The Benshaw Solid State Starter is an in-the-delta starter. The starter leads and motor leads are always energized. Catastrophic damage to the compressor motor will occur if supply power is applied while the system is in a vacuum.

## Identify Existing Solid State Starter

Trane has used three styles of solid state starters over the past several years. Determine whether the SSS is an A515, EasySTART or Intelligent Technology (IT) by comparing the unit to the photographs below.

Figure 1. A515 Solid State Starter



Figure 2. Cutler-Hammer Intelligent Technology (IT) Starter

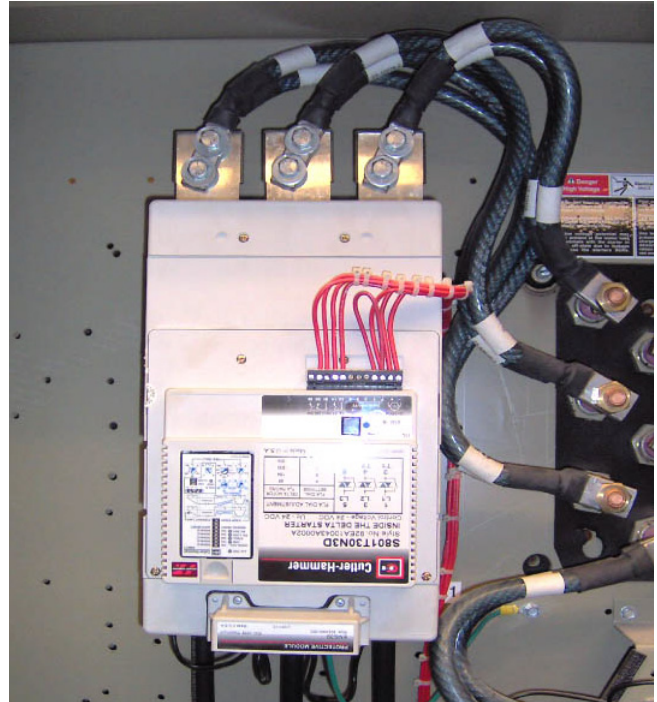
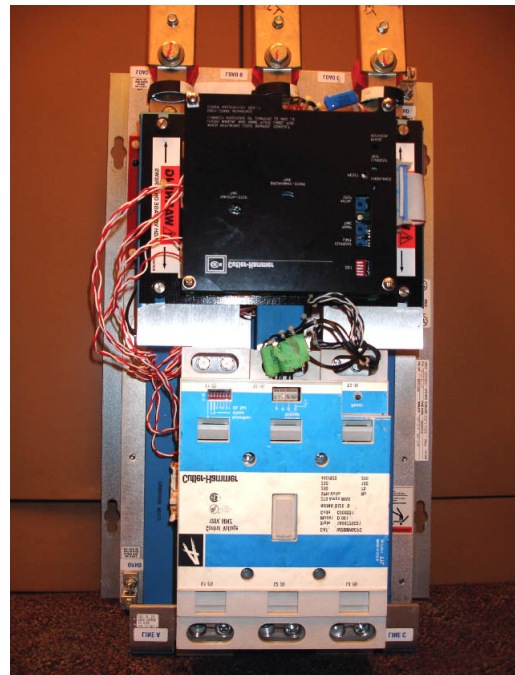

Figure 3. Cutler-Hammer EasySTART



## General Information

Once the type of starter is determined, proceed to the section in the bulletin that corresponds with the correct **unit** and **start type**.

**Important:** Always follow safe electrical practices while installing the new starter. Be certain to route new wiring neatly through the starter panel. Do not allow the wiring to come in contact with any sharp objects. It is advised to place fish paper between the bottom of the starter cabinet and wiring.

**Important:**

### UL REQUIREMENT

- The field conversion of the starter will void the factory UL listing.
- The customer must obtain a UL inspection if a UL listing is required.

## Removal of Existing Starter

See unit chapters for specific information on existing starter removal.

## Installation of Benshaw Starter

See unit chapters for graphics which show unit specific installation information and location of required components for the Benshaw RediStart SSS conversion.

**Notes:**

- All Benshaw Solid State Starters supplied after November 2010 are MX2 starters.
- The Benshaw Redistart SSS is supplied with current transformers. The current transformers wired to the chiller need to remain installed as shipped from the factory. The current transformers supplied with the solid state starter need to be installed as close to the original current transformers as possible for proper operation.
- See unit specific chapters for the proper installation location of the Benshaw current transformers.
- Benshaw CTs are polarity sensitive. For specific details on mounting of the Benshaw Solid State Starter, see Benshaw Solid State Starter Hardware Manual, pages 20-32. The manual ships with the Benshaw starter.
- Secure locally any required low voltage wire, bolts, nuts and other hardware as required.

## Additional Components

### Pilot Relay

See unit chapters for specific information on pilot relays. See [Table 8, p. 47](#) for part numbers.

### Cabinet Fan (optional)

A locally obtained cabinet fan needs to be installed in the cabinet to avoid overheating. The fan can be mounted internal or external to the cabinet. See [Table 8, p. 47](#) for part numbers.

**Note:** The fan can be mounted over the existing vents on the cabinet. It is not necessary to cut a hole on the cabinet.

### Circuit Breaker and Shunt Trip

**Important:** All units that are converted to the Benshaw RediStart Solid Start Starter REQUIRE a circuit breaker and shunt trip device.

- If the unit was built with a circuit breaker, contact Trane Service Parts for shunt option or source locally.
- If unit was NOT built with a circuit breaker, one must be added, as well as the shunt breaker as listed above. Contact Trane Service Parts for circuit breaker information.

Refer to local and state electrical codes for proper sizing of the shunt trip device.

### Benshaw Remote Display Panel

The remote display panel is recommended if voltage and current monitoring is necessary. See ["Remote Keypad," p. 41](#) for further details.

### Warning Label

Two warning labels, part number LBL00419 and shown in [Figure 4](#), are required for each unit. Install one each by motor terminals AND on outside of panel.

**Note:** LBL00419 is a single label. You must order quantity two (2) for each unit.

Figure 4. Warning label



## Wiring

### **⚠ WARNING**

#### **Hazardous Voltage w/Capacitors!**

Failure to disconnect power and discharge capacitors before servicing could result in death or serious injury. Disconnect all electric power, including remote disconnects and discharge all motor start/run capacitors before servicing. Follow proper lockout/tagout procedures to ensure the power cannot be inadvertently energized. For variable frequency drives or other energy storing components provided by Trane or others, refer to the appropriate manufacturer's literature for allowable waiting periods for discharge of capacitors. Verify with a CAT III or IV voltmeter rated per NFPA 70E that all capacitors have discharged.

### **NOTICE**

#### **Starter Damage!**

Use of power factor correction or surge capacitors on the load side of the starter will result in serious damage to the starter that will NOT be covered by the starter warranty. The capacitors MUST be connected to the line side of the starter. The up-to-speed (UTS) contact can be used to energize the capacitors after the motor has reached full speed. Do NOT connect the capacitors between the starter and motor. See RTHC-SVD02\*-EN for further details.

## Low Voltage

The next step is the interconnecting wiring between the existing controls and the new Benshaw Redistart starter. Each unit specific chapter includes a basic schematic showing the necessary wiring for the controls. Use the same wire size that was used for the original wiring.

**Note:** 14 gauge wire is sufficient for most applications.  
Adhere to all state and local electrical codes.

## High Voltage

Wire the high voltage/power supply from the starter to the compressor. Use the specified Starter Power Lead Kit listed in [Table 7, p. 47](#). Follow the schematic in unit specific chapters.

# RTHA Units with Wye-Delta Starters

## Removal of Existing Starter

**⚠ WARNING**

**Hazardous Voltage!**  
 Failure to disconnect power before servicing could result in death or serious injury. Disconnect all electric power, including remote disconnects before servicing. Follow proper lockout/tagout procedures to ensure the power can not be inadvertently energized. Verify that no power is present with a voltmeter.

- 2R1-2R6 Resistors
- 2K1-2K4 Contactors
- 2U1 monitor
- Optional voltage/current meters

Figure 5, p. 8 shows the basic layout of the Wye-Delta starter with the components that need to be removed highlighted.

**Note:** If the optional voltage/current meters are mounted on the cabinet door, they must be removed for the new starter to fit properly. Once the meters are removed, block-off plates can be obtained locally. Install per your state and local codes.

The following components of an Wye -Delta starter need to be removed prior to installing the RediStart starter:

Figure 5. Remove the highlighted components (wye-delta starter) — RTHA-YD

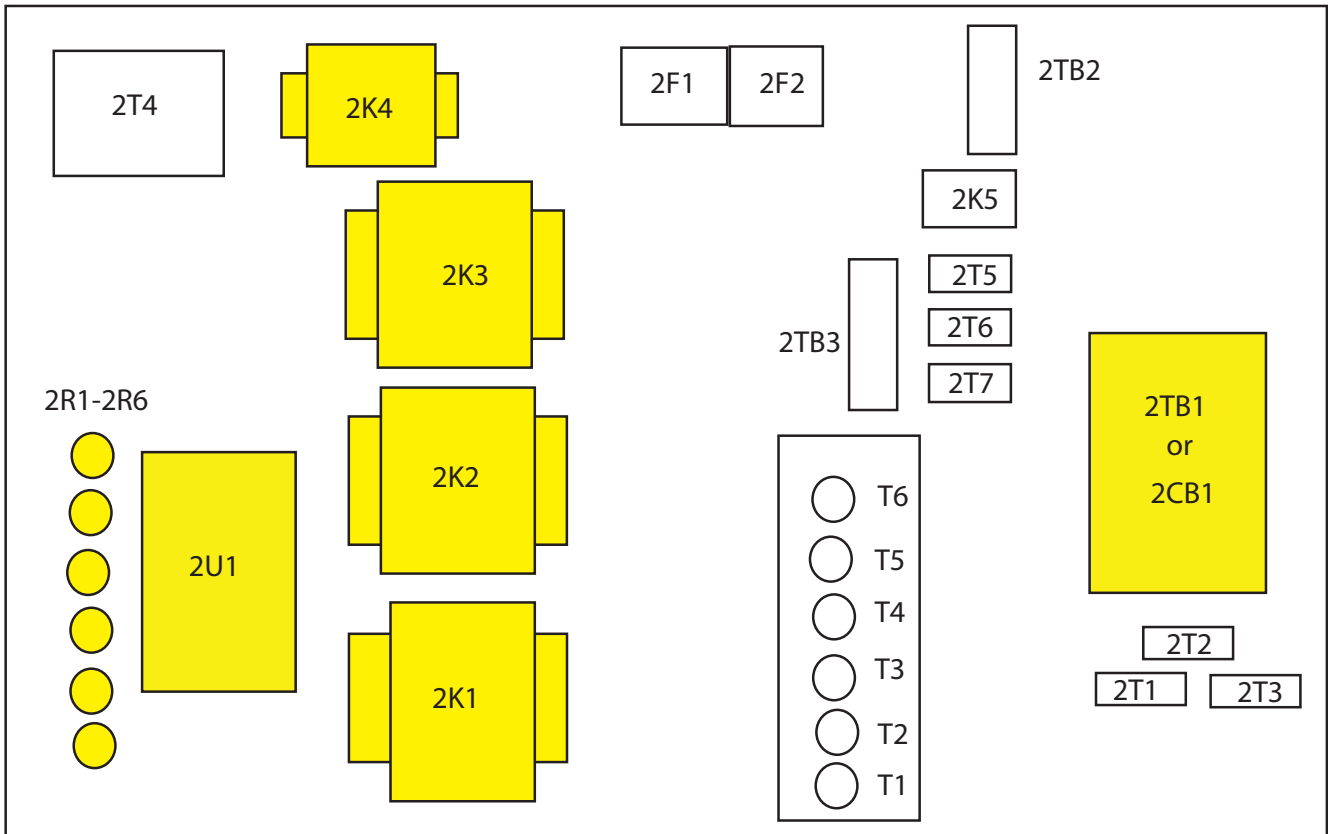
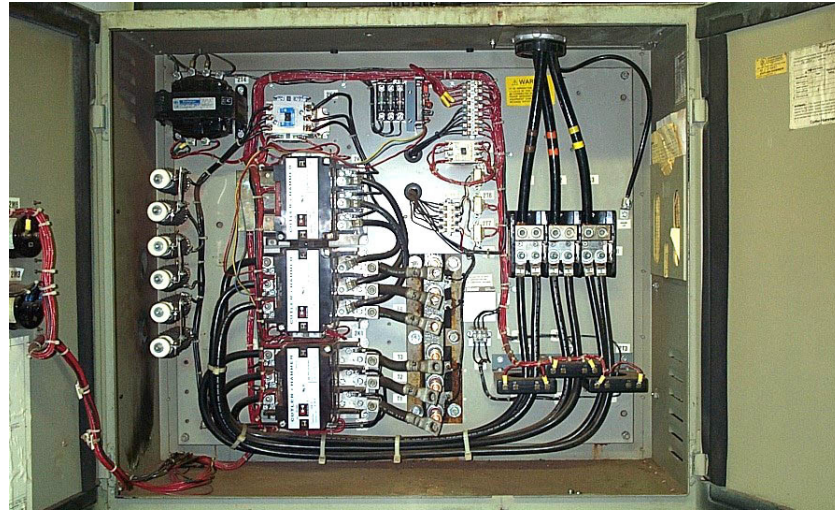



Figure 6. Photograph of wye-delta starter



## Installation of Benshaw Starter

Once all of the wye-delta starter components in [Figure 5, p. 8](#) are removed, refer to [Figure 7, p. 9](#) for the approximate locations of the new Restart components.

**Note:** 2K300 and 2K400 can be placed in either location noted below.

Figure 7. Location of Benshaw starter and additional components (highlighted) — RTHA

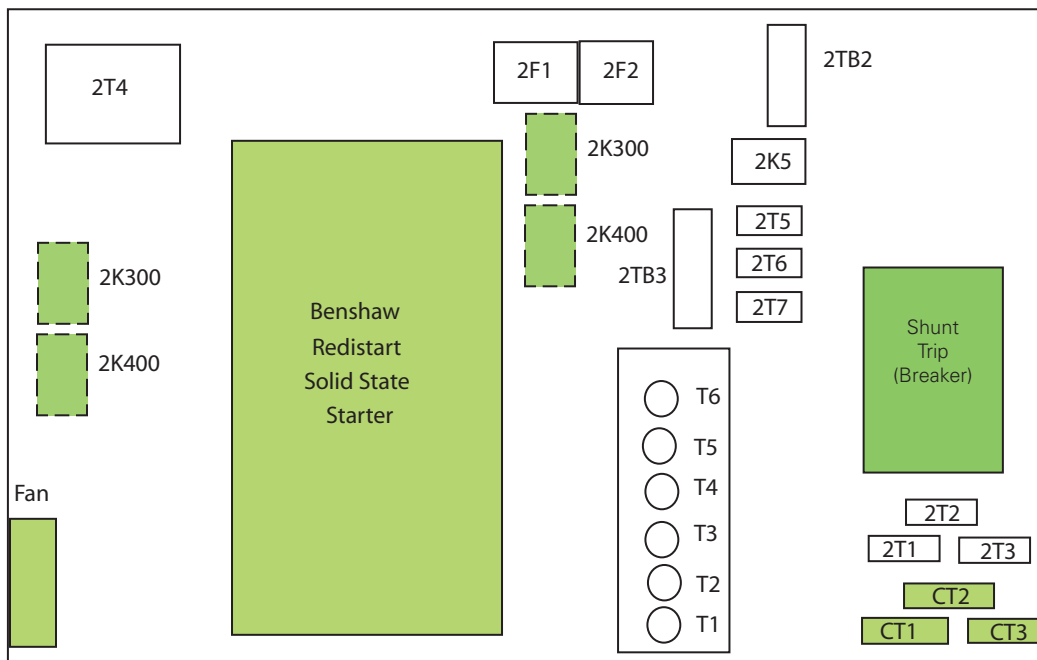

The Benshaw Restart SSS is supplied with current transformers. The current transformers wired to the chiller need to remain installed as shipped from the factory. The current transformers supplied with the solid state starter need to be installed as close to the original current transformers as possible for proper operation.

**Note:** Benshaw CTs are polarity sensitive. For specific details on mounting of the Benshaw Solid State Starter, see *Benshaw Solid State Starter Hardware Manual*, pages 20-32. The manual ships with the Benshaw starter.



## RTHA Units with Wye-Delta Starters

### Additional Components

See “Additional Components,” p. 6 in General Information chapter for more information.

### Pilot Relays

Two additional relays need to be installed for proper operation. The relays are labeled as 2K400 and 2K300 on the included wiring schematic. See [Table 8, p. 47](#) for part numbers.

### Wiring

Once the components are mounted and wired, skip to “[Quick Start, Initial Parameters](#),” p. 38 to set up the controls for proper operation.

#### **⚠ WARNING**

##### **Hazardous Voltage w/Capacitors!**

Failure to disconnect power and discharge capacitors before servicing could result in death or serious injury. Disconnect all electric power, including remote disconnects and discharge all motor start/run capacitors before servicing. Follow proper lockout/tagout procedures to ensure the power cannot be inadvertently energized. For variable frequency drives or other energy storing components provided by Trane or others, refer to the appropriate manufacturer’s literature for allowable waiting periods for discharge of capacitors. Verify with a CAT III or IV voltmeter rated per NFPA 70E that all capacitors have discharged.

#### **NOTICE**

##### **Starter Damage!**

Use of power factor correction or surge capacitors on the load side of the starter will result in serious damage to the starter that will NOT be covered by the starter warranty. The capacitors MUST be connected to the line side of the starter. The up-to-speed (UTS) contact can be used to energize the capacitors after the motor has reached full speed. Do NOT connect the capacitors between the starter and motor. See RTHC-SVD02\*-EN for further details.

### Low Voltage

The next step is the interconnecting wiring between the existing controls and the new Benshaw Redistart starter. [Figure 8, p. 11](#) is the basic schematic showing the necessary wiring for the MX starter. [Figure 9, p. 12](#) is the schematic for the MX2 starter. Use the same wire size that was used for the original wiring.

**Note:** 14 gauge wire is sufficient for most applications. Adhere to all state and local electrical codes.

### High Voltage

Wire the high voltage/power supply from the starter to the compressor. Use the Starter Power Lead kits called out in [Table 7, p. 47](#). Follow the schematic shown in [Figure 10, p. 13](#).

# RTHA Units with Wye-Delta Starters

Figure 8. Control power wiring (new wiring bold/highlighted in red) — RTHA (MX starter)

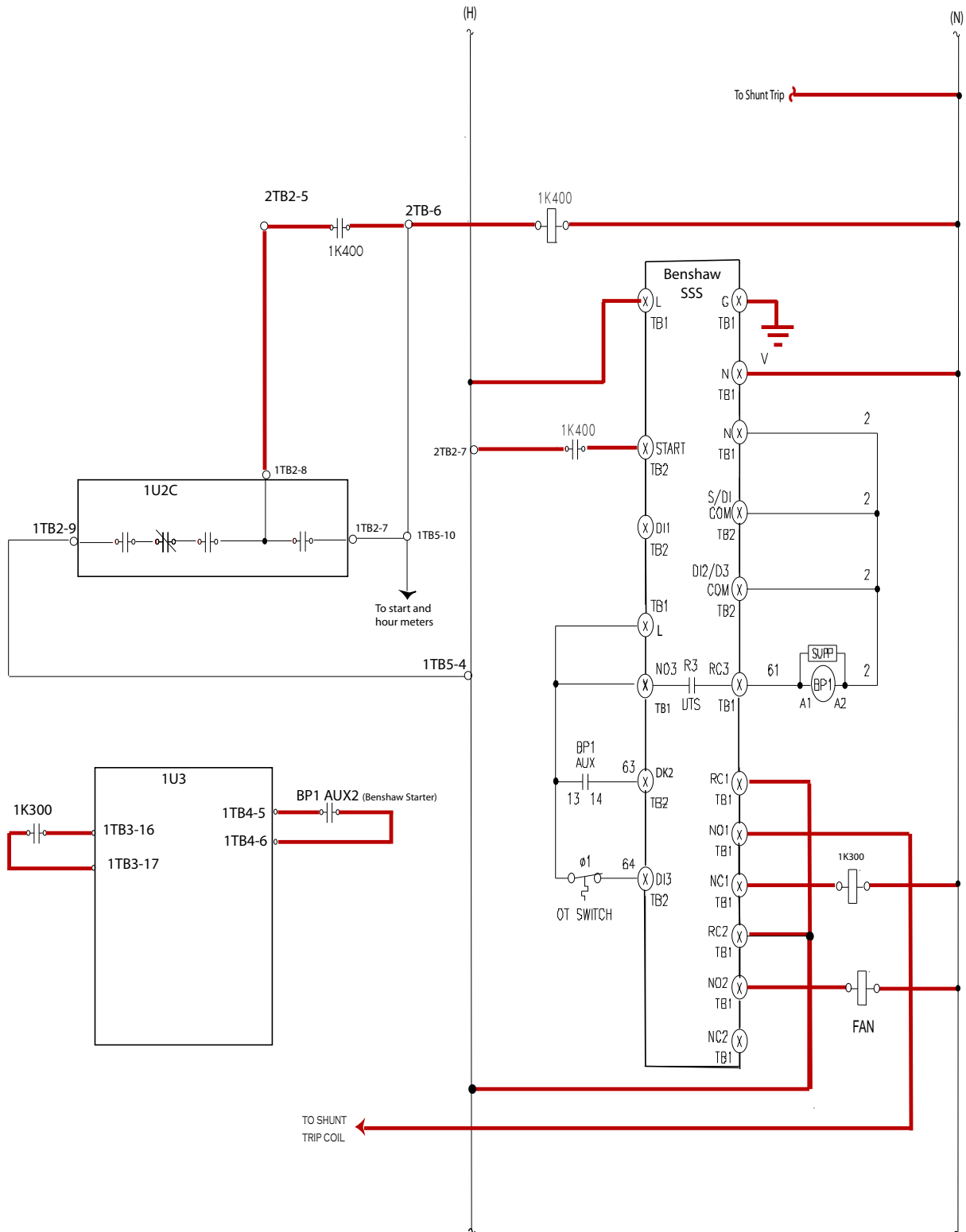



Figure 9. Control power wiring (new wiring bold/highlighted in red) — RTHA (MX2 starter)

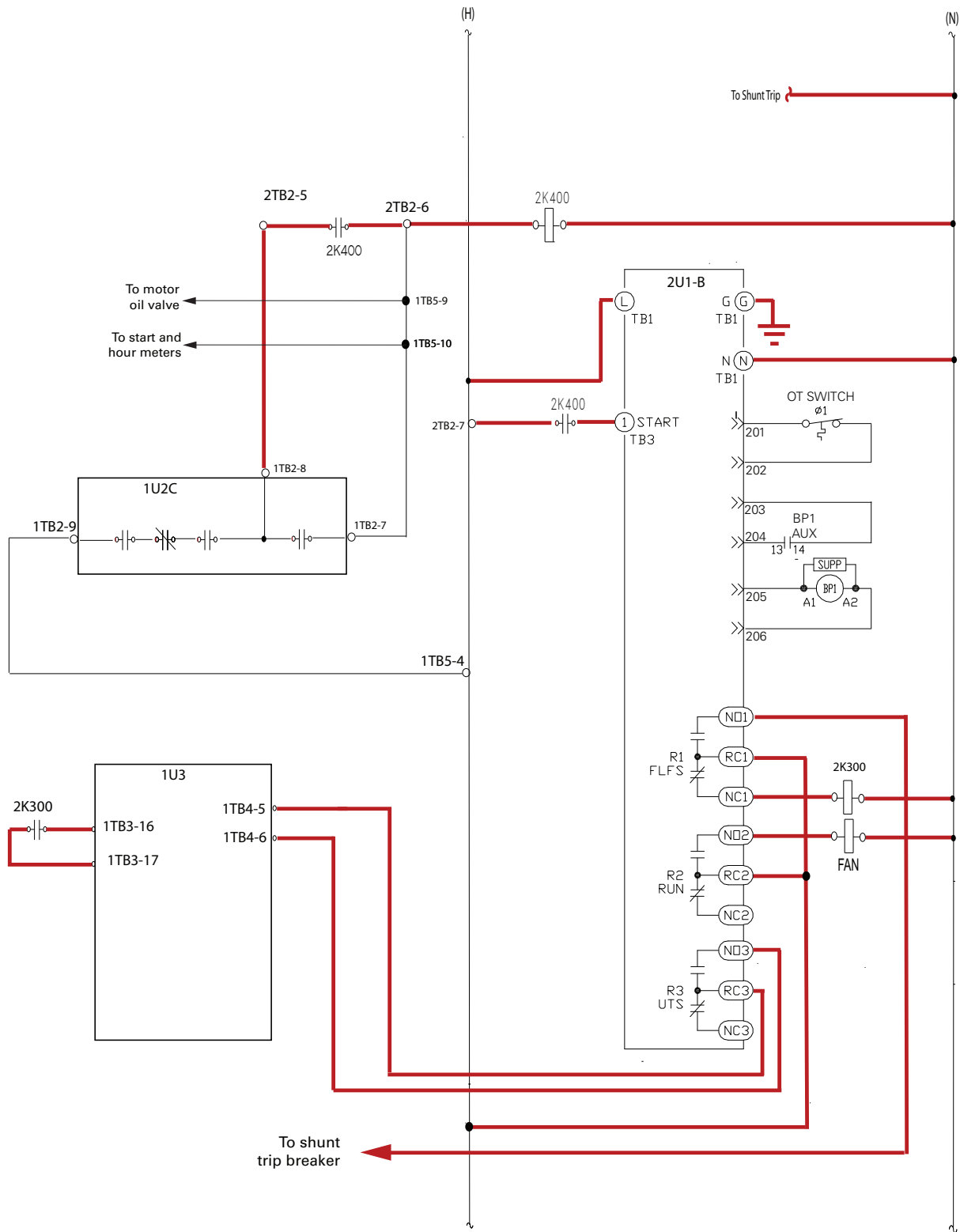
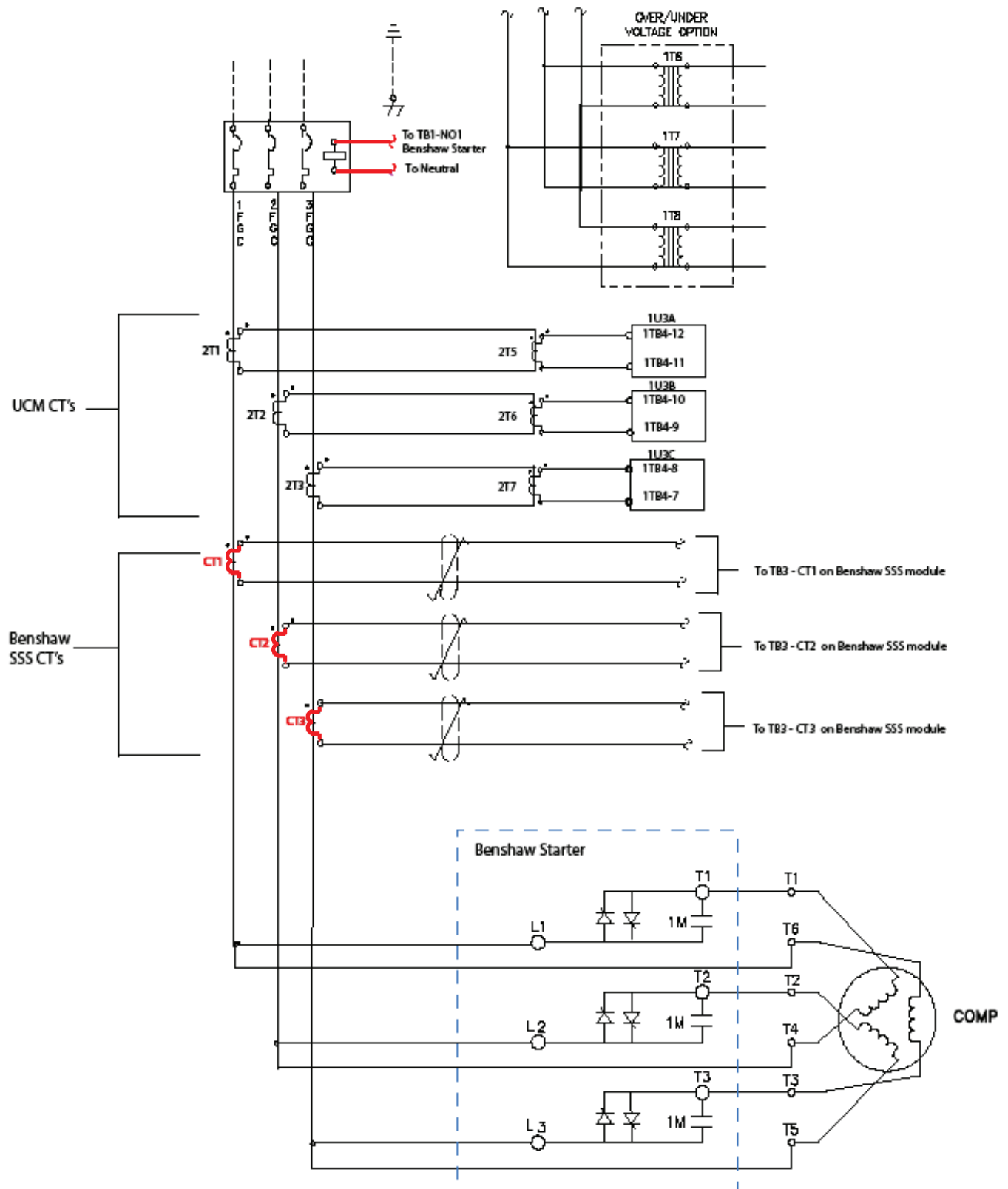

Figure 10. Power wire (new wiring bold/highlighted in red) — RTHA



# RTHB Units with A515 (or Wye-Delta) Starters

## Removal of Existing Starter

**⚠ WARNING**

**Hazardous Voltage w/Capacitors!**

Failure to disconnect power and discharge capacitors before servicing could result in death or serious injury. Disconnect all electric power, including remote disconnects and discharge all motor start/run capacitors before servicing. Follow proper lockout/tagout procedures to ensure the power cannot be inadvertently energized. For variable frequency drives or other energy storing components provided by Trane or others, refer to the appropriate manufacturer's literature for allowable waiting periods for discharge of capacitors. Verify with a CAT III or IV voltmeter rated per NFPA 70E that all capacitors have discharged.

- Power poles
- CFR mounted on 2TB3
- 2TRTimer
- MOV behind the 2U1 module
- 2CR1 control relay

For units with wye-delta starters, remove the associated contactors and resistors. See ["RTHA Units with Wye-Delta Starters," p. 8](#) for an example.

Figure 11, p. 14 shows the basic layout of the A515 starter with the components that need to be removed highlighted.

The following components of an A515 Cutler Hammer SSS need to be removed prior to installing the RediStart starter:

**Figure 11. Remove the highlighted components (A515 starter) — RTHB**

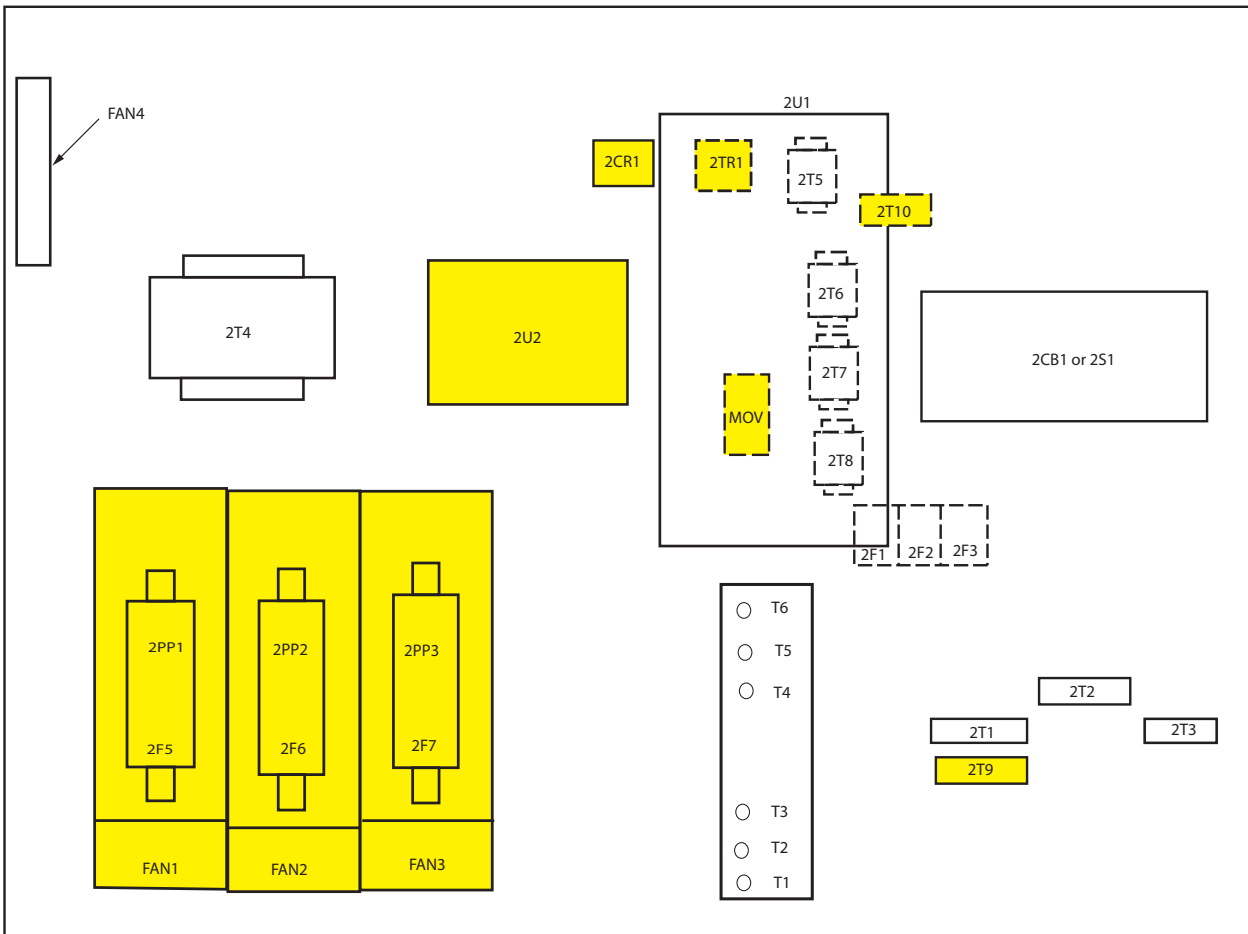

Figure 12. Photograph of A515 solid state starter



## Installation of Benshaw Starter

Once all of the A515 components in [Figure 12, p. 15](#) are removed, the 2T4 transformer needs to be moved to make

room for the new Benshaw starter. See [Figure 13, p. 15](#) for the approximate locations of the new Restart components.

Figure 13. Location of Benshaw starter and additional components (highlighted) — RTHB

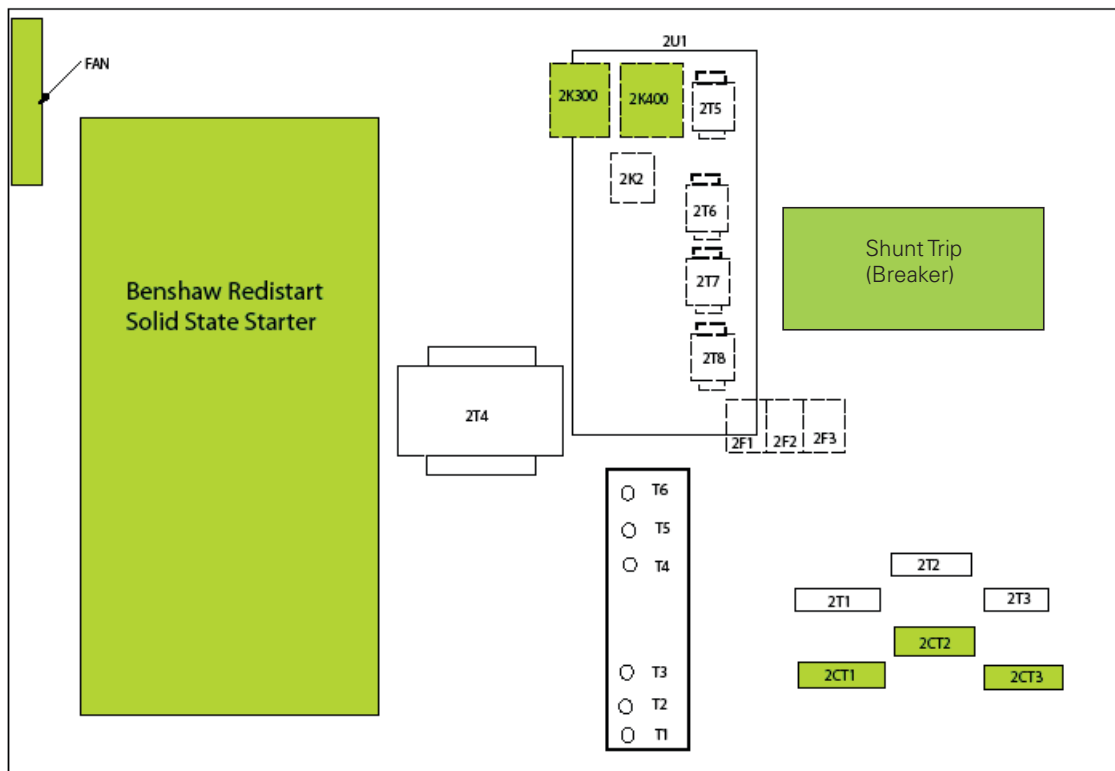

## RTHB Units with A515 (or Wye-Delta) Starters

The Benshaw Redistart SSS is supplied with current transformers. The current transformers wired to the chiller need to remain installed as shipped from the factory. The current transformers supplied with the solid state starter need to be installed as close to the original current transformers as possible for proper operation.

**Note:** *Benshaw CTs are polarity sensitive. For specific details on mounting of the Benshaw Solid State Starter, see the Benshaw Solid State Starter Hardware Manual pages 20-32. The manual ships with the Benshaw starters.*

## Additional Components

See “Additional Components,” p. 6 in General Information chapter for more information.

### Pilot Relays

Two additional relays need to be installed for proper operation. The relays are labeled as 2K400 and 2K300 on the included wiring schematic. See [Table 8, p. 47](#) for part numbers.

### Resistor

To avoid an informational warning of Heat Sink Temp Sensor that the new solid state starter no longer utilizes, place a 9.1-10kohm resistor on J7- 1 and J7-2.

**Note:** *The existing temperature sensor (2TR1) attached to the A515 pole can be dis-mounted from the power pole and left in the cabinet to act as a resistor between terminals J7-1 and J7-2.*

## All Components Installed

To help visualize how the wires can be routed between the existing starter module, compressor and the new Benshaw Redistart starter see photograph in [Figure 14, p. 16](#).

**Figure 14. Benshaw starter installed — RTHB**

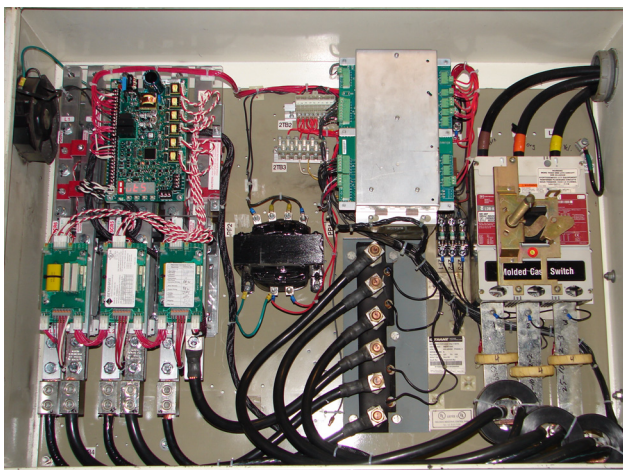

## Wiring

### ⚠ WARNING

#### Hazardous Voltage w/Capacitors!

Failure to disconnect power and discharge capacitors before servicing could result in death or serious injury. Disconnect all electric power, including remote disconnects and discharge all motor start/run capacitors before servicing. Follow proper lockout/tagout procedures to ensure the power cannot be inadvertently energized. For variable frequency drives or other energy storing components provided by Trane or others, refer to the appropriate manufacturer’s literature for allowable waiting periods for discharge of capacitors. Verify with a CAT III or IV voltmeter rated per NFPA 70E that all capacitors have discharged.

### NOTICE

#### Starter Damage!

Use of power factor correction or surge capacitors on the load side of the starter will result in serious damage to the starter that will NOT be covered by the starter warranty. The capacitors MUST be connected to the line side of the starter. The up-to-speed (UTS) contact can be used to energize the capacitors after the motor has reached full speed. Do NOT connect the capacitors between the starter and motor. See RTHC-SVD02\*-EN for further details.

### Low Voltage

The next step is the interconnecting wiring between the existing controls and the new Benshaw Redistart starter. [Figure 15, p. 17](#) is the basic schematic showing the necessary wiring for the MX starter. [Figure 16, p. 18](#) is the schematic for the MX2 starter. Use the same wire size that was used for the original wiring.

**Note:** *14 gauge wire is sufficient for most applications. Adhere to all state and local electrical codes.*

### High Voltage

Wire the high voltage/power supply from the starter to the compressor. Notice that the original bus bars need to be cut in the field. Mount the new wiring directly to the bus bar according to local and state electrical codes. Use the Starter Power Lead kits called out in [Table 7, p. 47](#). Follow the schematic shown in [Figure 17, p. 19](#).

Once the components are mounted and wired, skip to “Quick Start, Initial Parameters,” p. 38 to set up the controls for proper operation.

## RTHB Units with A515 (or Wye-Delta) Starters

Figure 15. Control power wiring (new wiring bold/highlighted in red) — RTHB (MX starter)

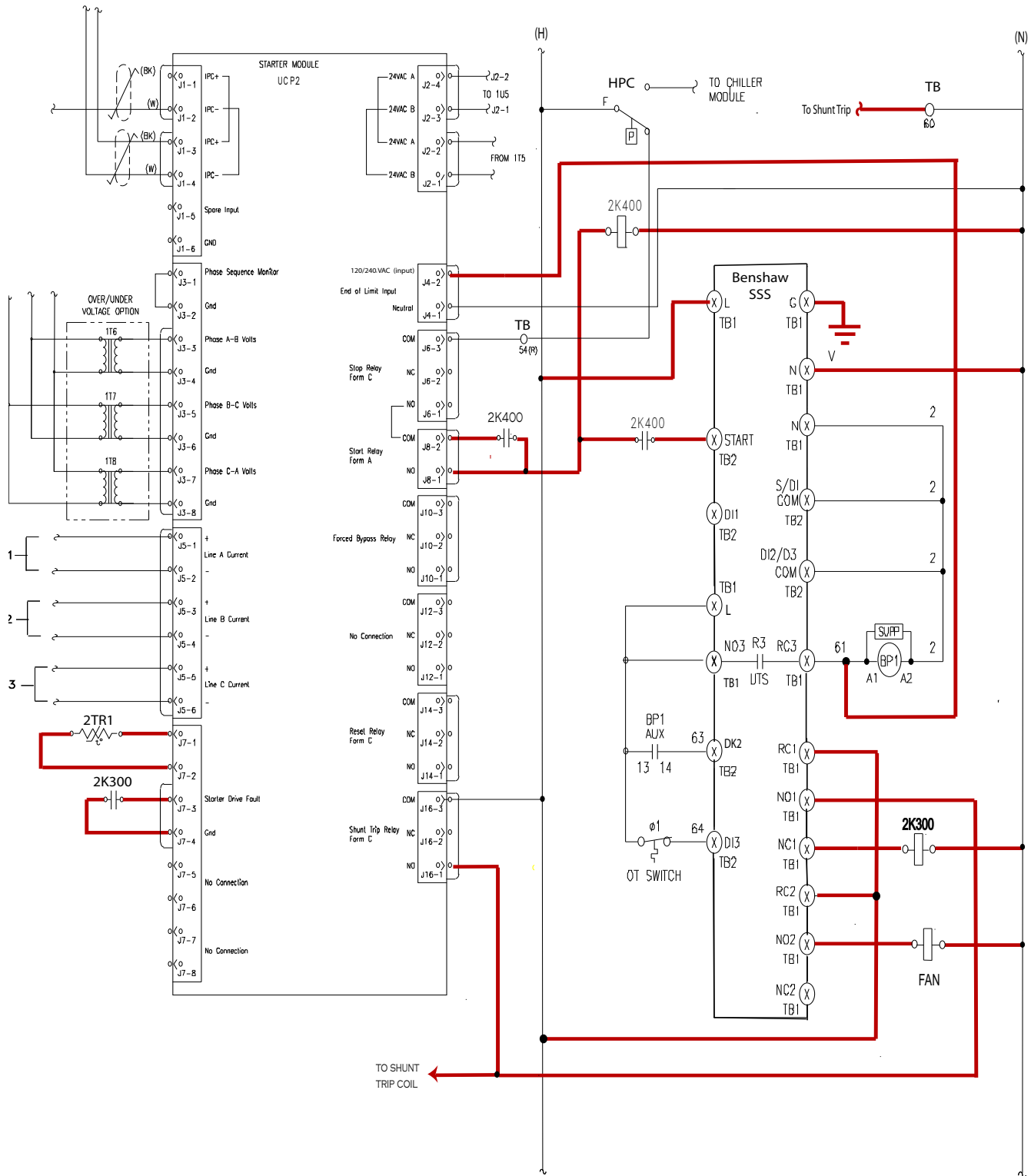

# RTHB Units with A515 (or Wye-Delta) Starters

Figure 16. Control power wiring (new wiring bold/highlighted in red) — RTHB (MX2 starter)

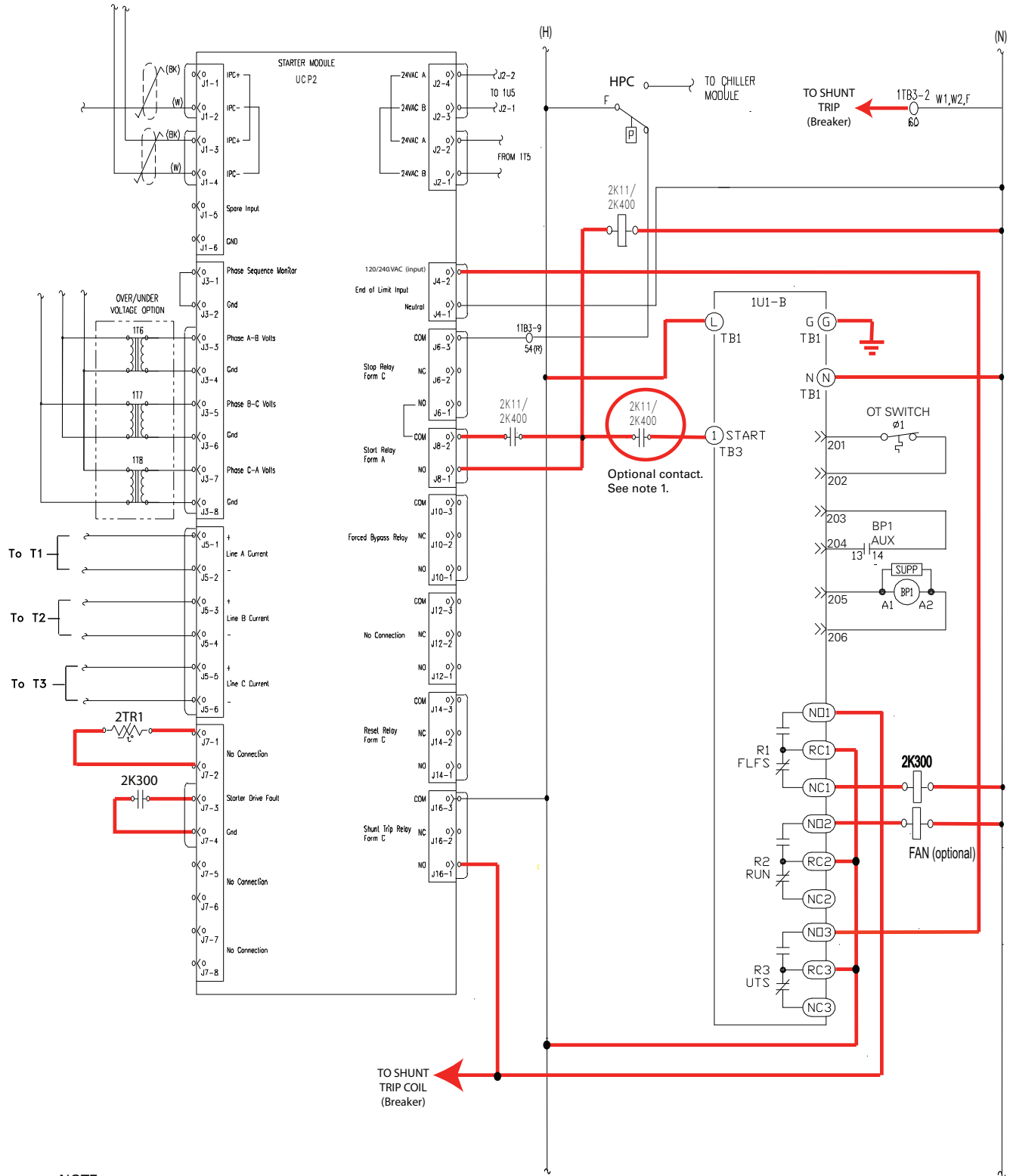

**NOTE:**

1. Connection to start signal is required. If you don't use this contact, you need to place a wire to the start signal.



## RTHB Units with A515 (or Wye-Delta) Starters

Figure 17. Power wiring (new wiring bold/highlighted in red) — RTHB

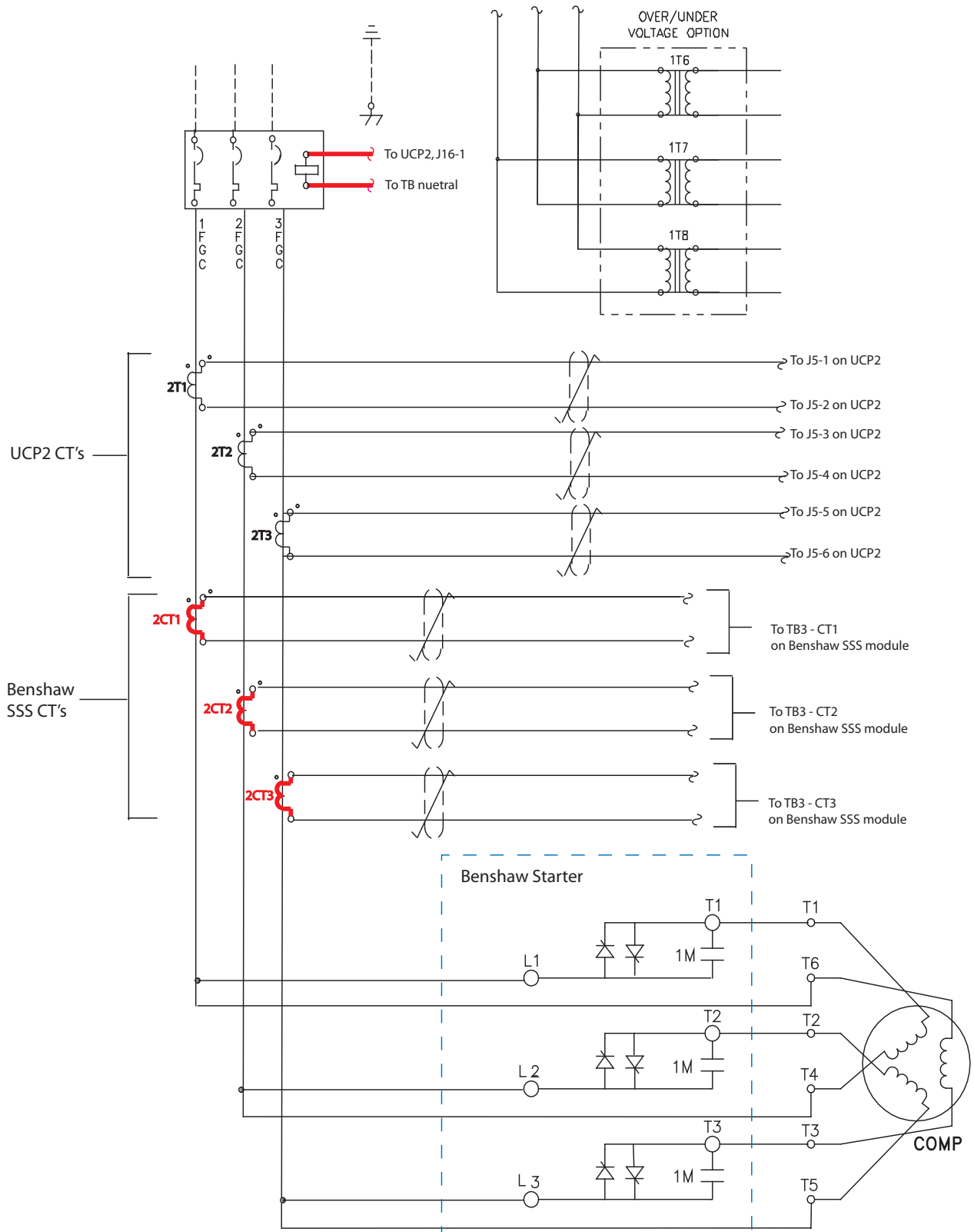



# RTHC Units with EasySTART (or Wye-Delta) Starter

## Removal of Existing Starter

**⚠ WARNING**

**Hazardous Voltage w/Capacitors!**

Failure to disconnect power and discharge capacitors before servicing could result in death or serious injury. Disconnect all electric power, including remote disconnects and discharge all motor start/run capacitors before servicing. Follow proper lockout/tagout procedures to ensure the power cannot be inadvertently energized. For variable frequency drives or other energy storing components provided by Trane or others, refer to the appropriate manufacturer's literature for allowable waiting periods for discharge of capacitors. Verify with a CAT III or IV voltmeter rated per NFPA 70E that all capacitors have discharged.

For units with an Easy Start Cutler Hammer SSS, remove the following components, location shown in [Figure 18](#):

- 1U11, EasySTART SSS
- 1K300 (replace)
- 1K400 (replace)
- 1TB1 terminal block

For units with wye-delta starters, remove the associated contactors and resistors. See "[RTHA Units with Wye-Delta Starters](#)," p. 8 for an example.

Figure 18. Remove highlighted components (EasySTART) — RTHC

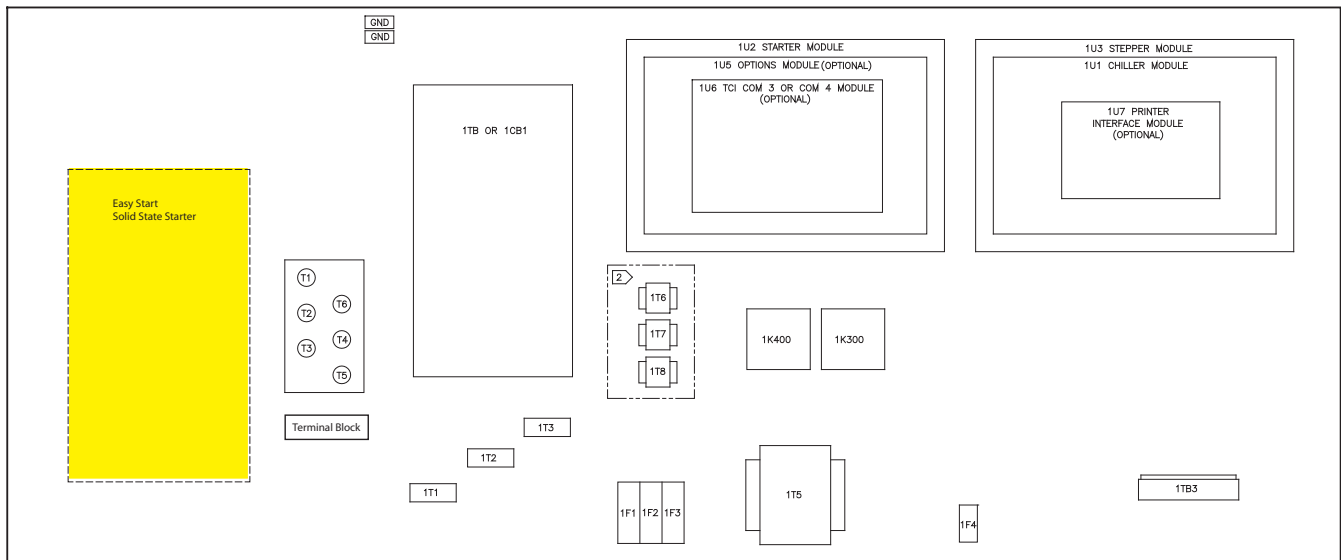

**Figure 19. Photograph of EasySTART — RTHC**

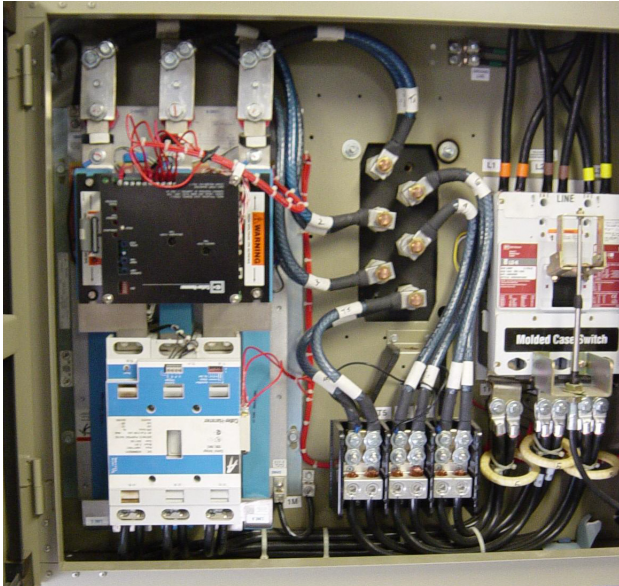

## Installation of Benshaw Starter

Once the EasySTART solid state starter is removed, mount the fan and the Benshaw solid state starter in the cabinet. See [Figure 20, p. 21](#) for an approximate location of components.

The Benshaw Redistart SSS is supplied with current transformers. The current transformers wired to the chiller need to remain installed as shipped from the factory. The current transformers supplied with the solid state starter need to be installed as close to the original current transformers as possible for proper operation.

**Note:** *Benshaw CTs are polarity sensitive. For specific details on mounting of the Benshaw Solid State Starter, refer to the Benshaw Solid State Starter Hardware Manual pages 20-32. The manual ships with the Benshaw starters.*

**Figure 20. Location of Benshaw starter and additional components (highlighted)**

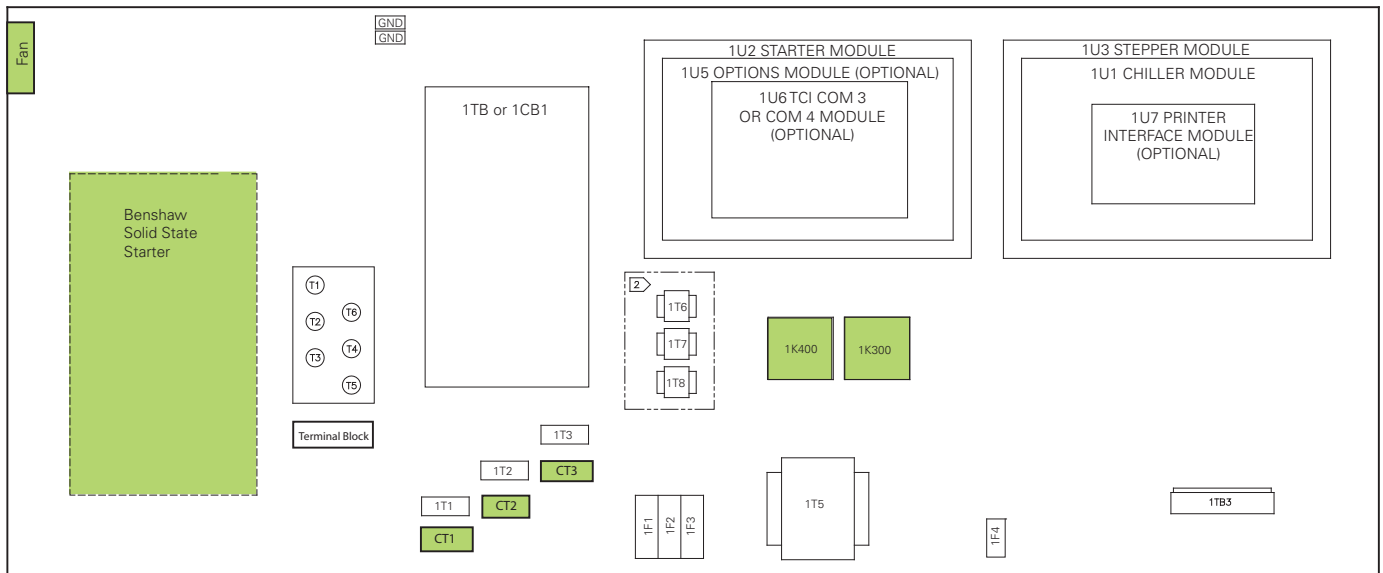

454



## RTHC Units with EasySTART (or Wye-Delta) Starter

### Additional Components

See “Additional Components,” p. 6 in General Information chapter for more information.

### Pilot Relays

It is recommended to replace the 1K300 and 1K400 relays when installing the new Benshaw Redistart SSS. The new pilot relays can be mounted in the same place as the original 1K300 and 1K400. See [Table 8, p. 47](#) for part numbers.

### Wiring

specified Starter Power Lead Kit listed in [Table 7, p. 47](#). Follow the schematic shown in [Figure 23, p. 25](#)

Once all of the components are installed and wiring is complete, skip to “Quick Start, Initial Parameters,” p. 38.

#### **⚠ WARNING**

##### **Hazardous Voltage w/Capacitors!**

Failure to disconnect power and discharge capacitors before servicing could result in death or serious injury. Disconnect all electric power, including remote disconnects and discharge all motor start/run capacitors before servicing. Follow proper lockout/tagout procedures to ensure the power cannot be inadvertently energized. For variable frequency drives or other energy storing components provided by Trane or others, refer to the appropriate manufacturer’s literature for allowable waiting periods for discharge of capacitors. Verify with a CAT III or IV voltmeter rated per NFPA 70E that all capacitors have discharged.

#### **NOTICE**

##### **Starter Damage!**

Use of power factor correction or surge capacitors on the load side of the starter will result in serious damage to the starter that will NOT be covered by the starter warranty. The capacitors MUST be connected to the line side of the starter. The up-to-speed (UTS) contact can be used to energize the capacitors after the motor has reached full speed. Do NOT connect the capacitors between the starter and motor. See RTHC-SVD02\*-EN for further details.

### Low Voltage

The next step is the interconnecting wiring between the existing controls and the new Benshaw Redistart starter. [Figure 21, p. 23](#) is the basic schematic showing the necessary wiring for the MX starter. [Figure 22, p. 24](#) is the schematic for the MX2 starter. Use the same wire size that was used for the original wiring.

**Note:** 14 gauge wire is sufficient for most applications. Adhere to all state and local electrical codes.

### High Voltage

Wire the high voltage/power supply from the starter to the compressor. Remove the existing terminal block and use the

## RTHC Units with EasySTART (or Wye-Delta) Starter

**Figure 21. Control power wiring (new wiring bold/highlighted in red) — RTHC (MX starter)**

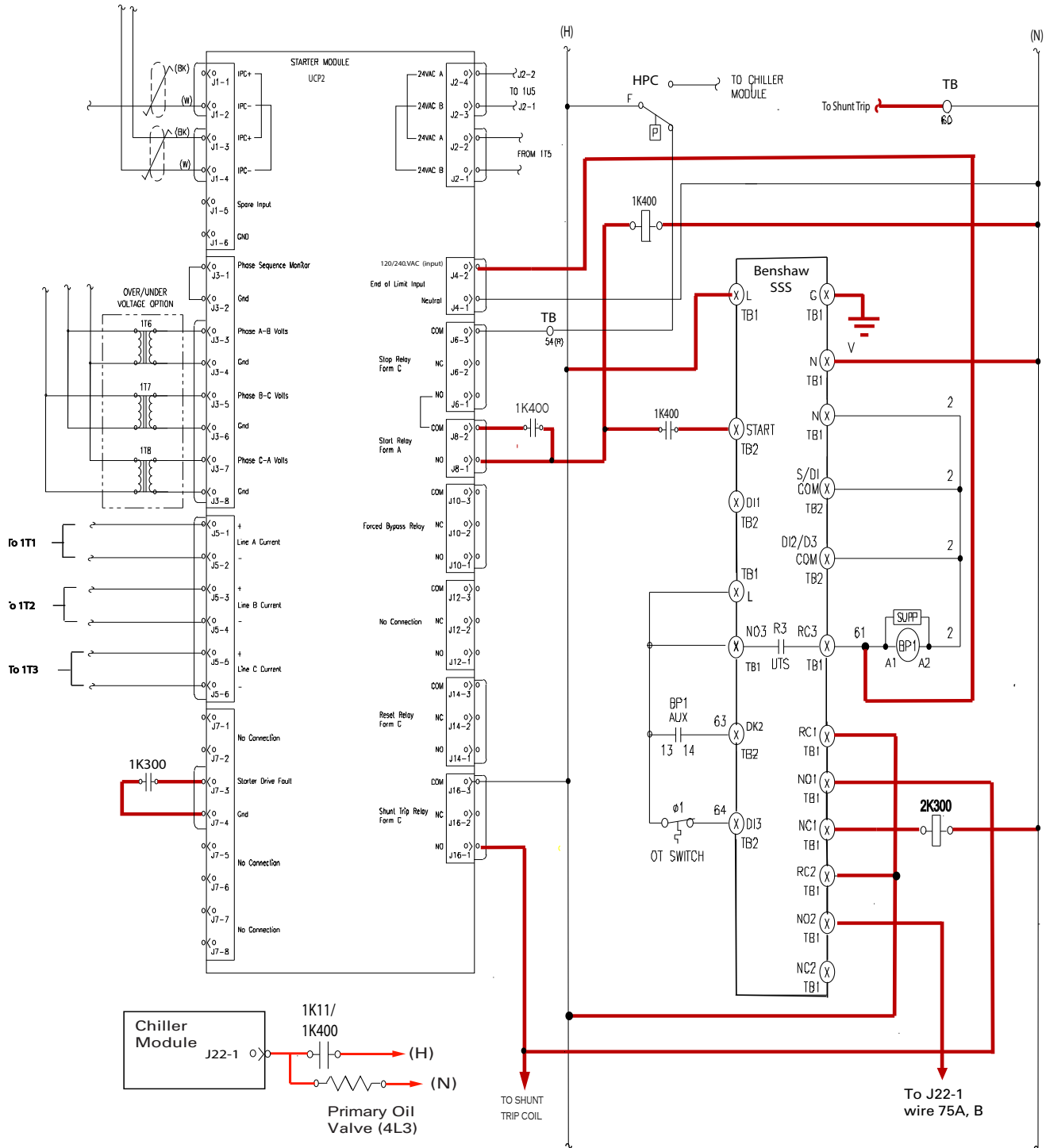

# RTHC Units with EasySTART (or Wye-Delta) Starter

Figure 22. Control power wiring (new wiring bold/highlighted in red) — RTHC(MX2 starter)

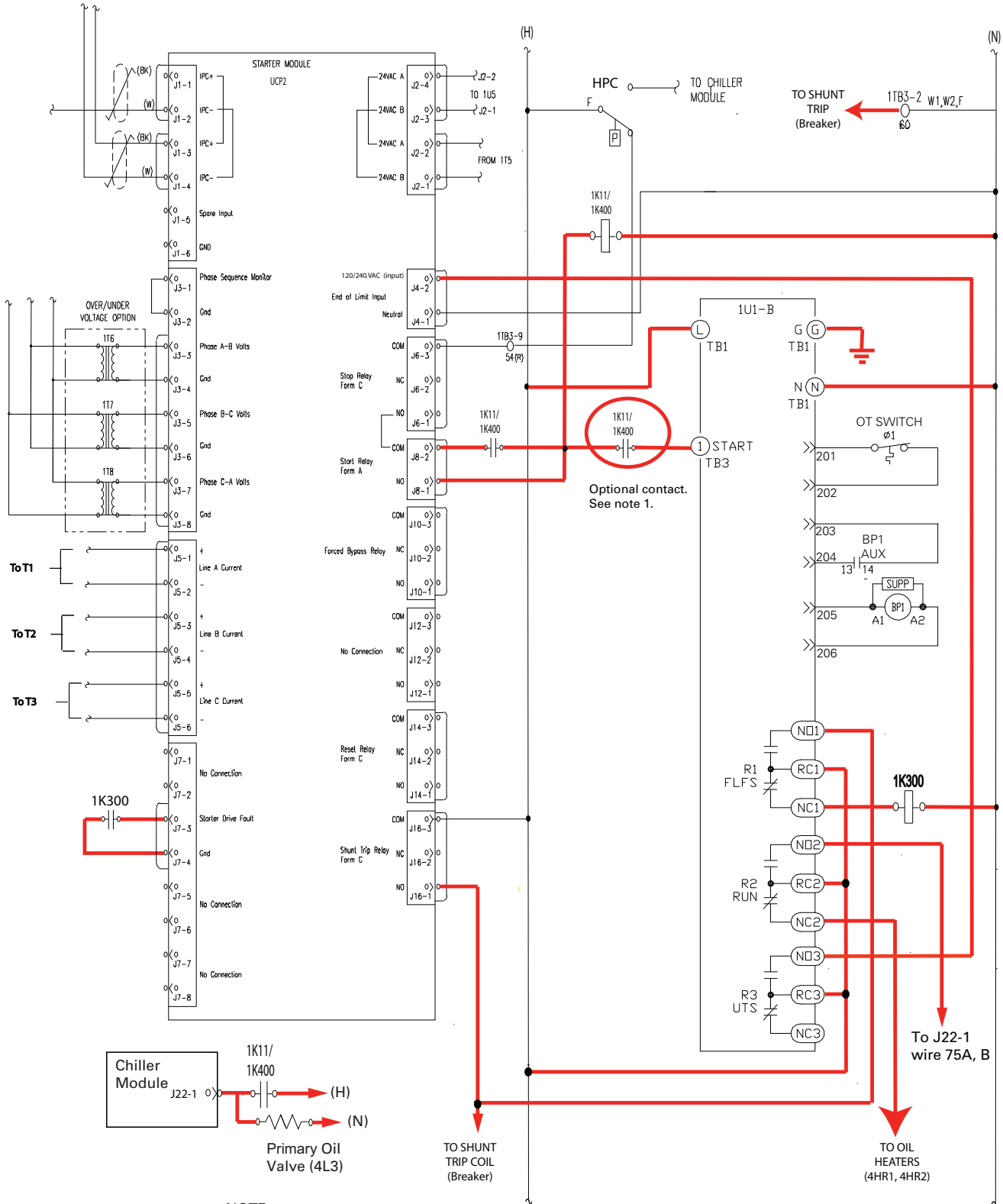

NOTE:  
1. Connection to start signal is required. If you don't use this contact, you need to place a wire to the start signal.

## RTHC Units with EasySTART (or Wye-Delta) Starter

**Figure 23. Power wiring (new wiring bold/highlighted in red) — RTHC**

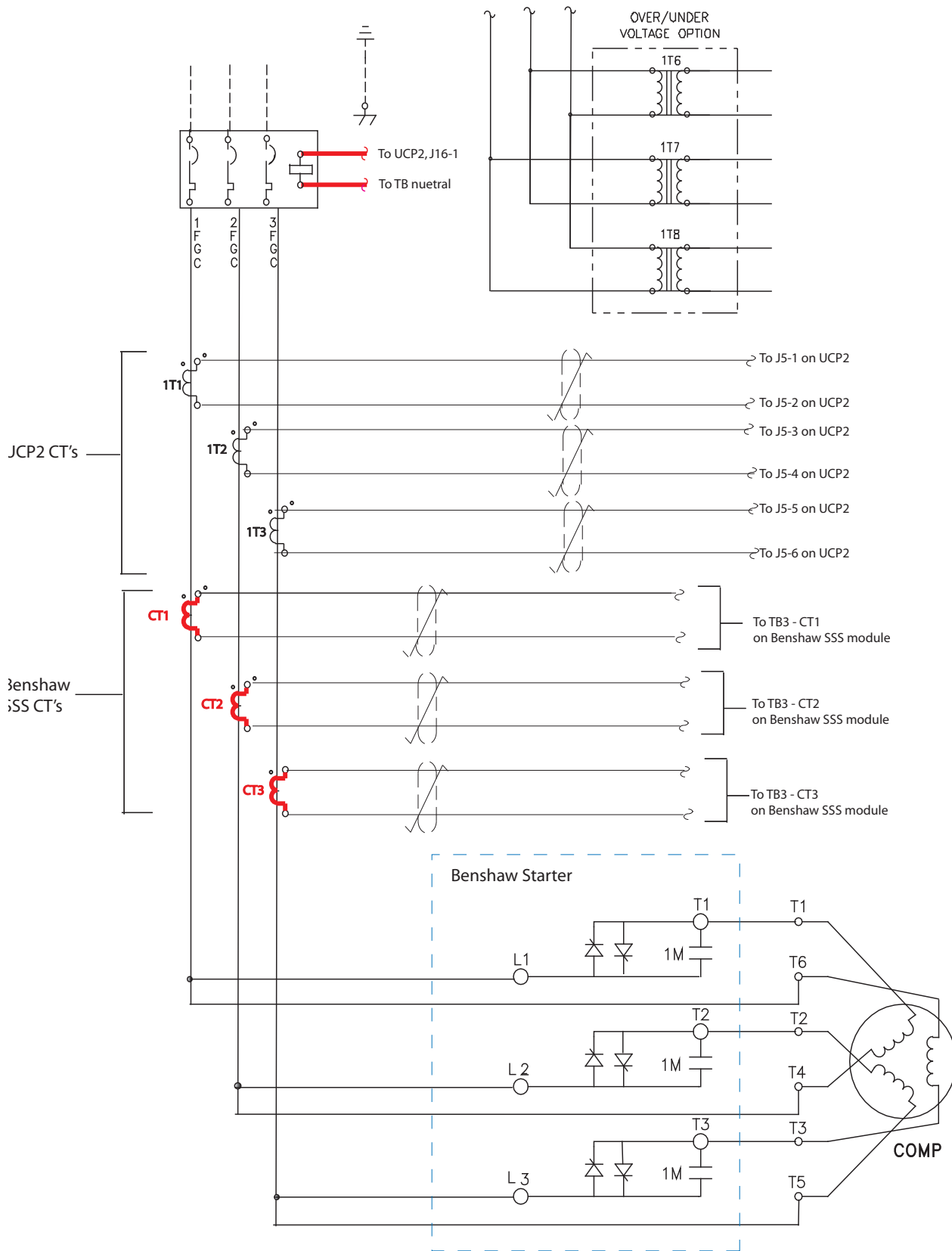





# RTHC Units with IT (or Wye-Delta) Starter

## Removal of Existing Starter

**⚠ WARNING**

**Hazardous Voltage w/Capacitors!**

Failure to disconnect power and discharge capacitors before servicing could result in death or serious injury. Disconnect all electric power, including remote disconnects and discharge all motor start/run capacitors before servicing. Follow proper lockout/tagout procedures to ensure the power cannot be inadvertently energized. For variable frequency drives or other energy storing components provided by Trane or others, refer to the appropriate manufacturer's literature for allowable waiting periods for discharge of capacitors. Verify with a CAT III or IV voltmeter rated per NFPA 70E that all capacitors have discharged.

The following components of an Intelligent Technology (IT) SSS need to be removed prior to installing the Benshaw RediStart starter:

- Intelligent Technology (IT) Starter
- MOV
- 1PS
- 1K400 (replace)
- 1TB1

For units with wye-delta starters, remove the associated contactors and resistors. See ["RTHA Units with Wye-Delta Starters," p. 8](#) for an example.

[Figure 24, p. 26](#) shows the basic layout of the IT starter with the components that need to be removed highlighted.

Figure 24. Remove the highlighted components (IT starter) — RTHC

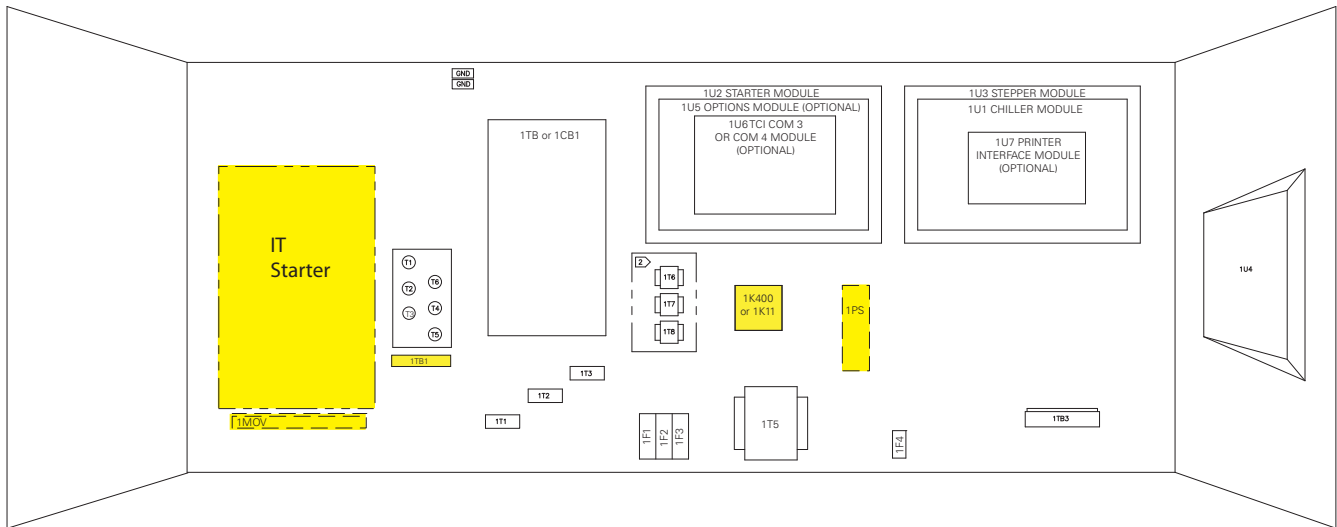
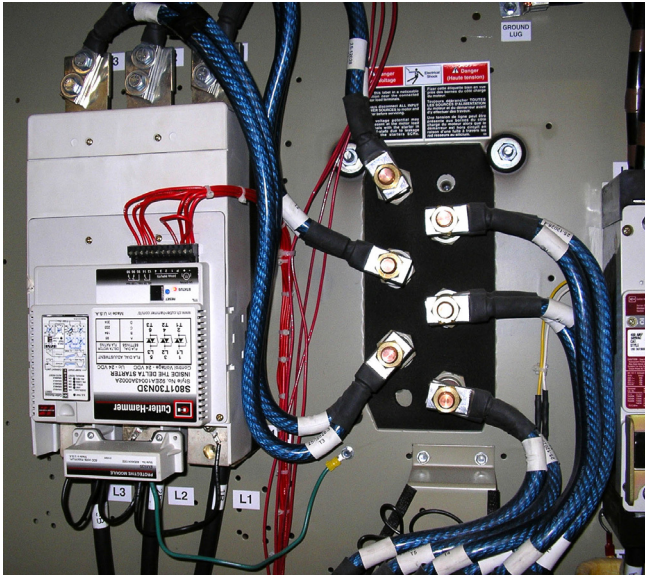

Figure 25. Photograph of IT solid state starter — RTHC



### Installation of Benshaw Starter

Once all of the above components are removed, see [Figure 26, p. 27](#) for the approximate locations of the new components.

The Benshaw Redistart SSS is supplied with current transformers. The current transformers wired to the chiller need to remain installed as shipped from the factory. The current transformers supplied with the solid state starter need to be installed as close to the original current transformers as possible for proper operation. See [Figure 29, p. 31](#) for proper installation location of the Benshaw current transformers.

**Note:** *Benshaw CTs are polarity sensitive. For specific details on mounting of the Benshaw Solid State Starter, refer to the Benshaw Solid State Starter Hardware Manual pages 20-32. The manual ships with the Benshaw starters.*

Figure 26. Location of benshaw starter and additional components (highlighted) — RTHC

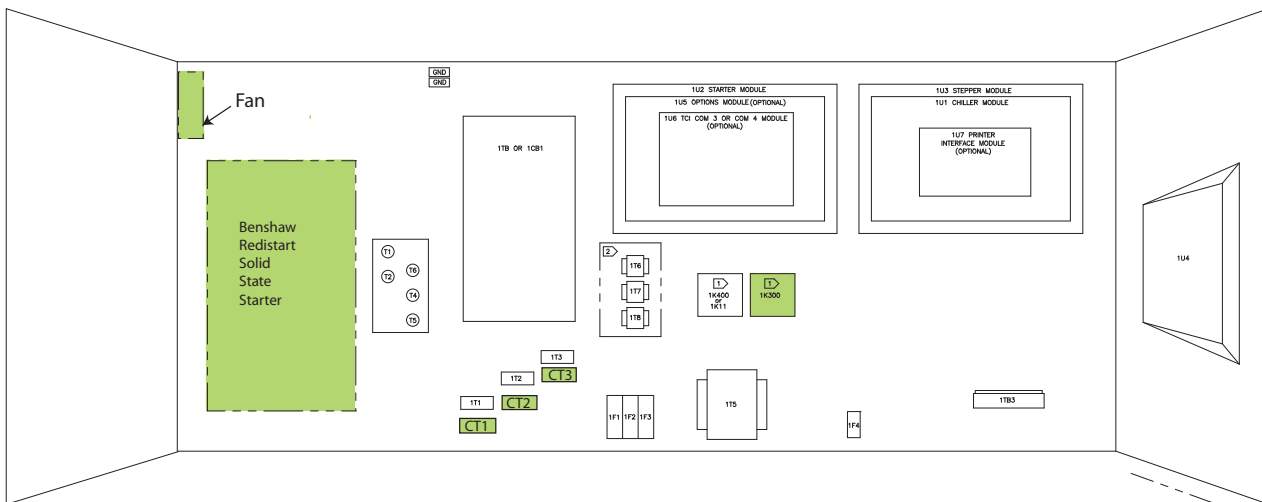



## RTHC Units with IT (or Wye-Delta) Starter

### Additional Components

See “Additional Components,” p. 6 in General Information chapter for more information.

### Pilot Relay

It is recommended to replace the 1K300 and 1K400 relays when installing the new Benshaw SSS. The new pilot relays can be mounted in the same place as the original 1K300 and 1K400. See [Table 8, p. 47](#) for part numbers.

### Wiring

specified Starter Power Lead Kit listed in [Table 7, p. 47](#). Follow the schematic shown in [Figure 29, p. 31](#)

Once all of the components are installed and wiring is complete, skip to “Quick Start, Initial Parameters,” p. 38.

#### **⚠ WARNING**

##### **Hazardous Voltage w/Capacitors!**

Failure to disconnect power and discharge capacitors before servicing could result in death or serious injury. Disconnect all electric power, including remote disconnects and discharge all motor start/run capacitors before servicing. Follow proper lockout/tagout procedures to ensure the power cannot be inadvertently energized. For variable frequency drives or other energy storing components provided by Trane or others, refer to the appropriate manufacturer’s literature for allowable waiting periods for discharge of capacitors. Verify with a CAT III or IV voltmeter rated per NFPA 70E that all capacitors have discharged.

#### **NOTICE**

##### **Starter Damage!**

Use of power factor correction or surge capacitors on the load side of the starter will result in serious damage to the starter that will NOT be covered by the starter warranty. The capacitors MUST be connected to the line side of the starter. The up-to-speed (UTS) contact can be used to energize the capacitors after the motor has reached full speed. Do NOT connect the capacitors between the starter and motor. See RTHC-SVD02\*-EN for further details.

### Low Voltage

The next step is the interconnecting wiring between the existing controls and the new Benshaw Redistart starter. [Figure 27, p. 29](#) is the basic schematic showing the necessary wiring for the MX starter. [Figure 28, p. 30](#) is the schematic for the MX2 starter. Use the same wire size that was used for the original wiring.

**Note:** 14 gauge wire is sufficient for most applications. Adhere to all state and local electrical codes.

### High Voltage

Wire the high voltage/power supply from the starter to the compressor. Remove the existing terminal block and use the

## RTHC Units with IT (or Wye-Delta) Starter

Figure 27. Control power wiring (new wiring bold/highlighted in red) — RTHC(MX starter)

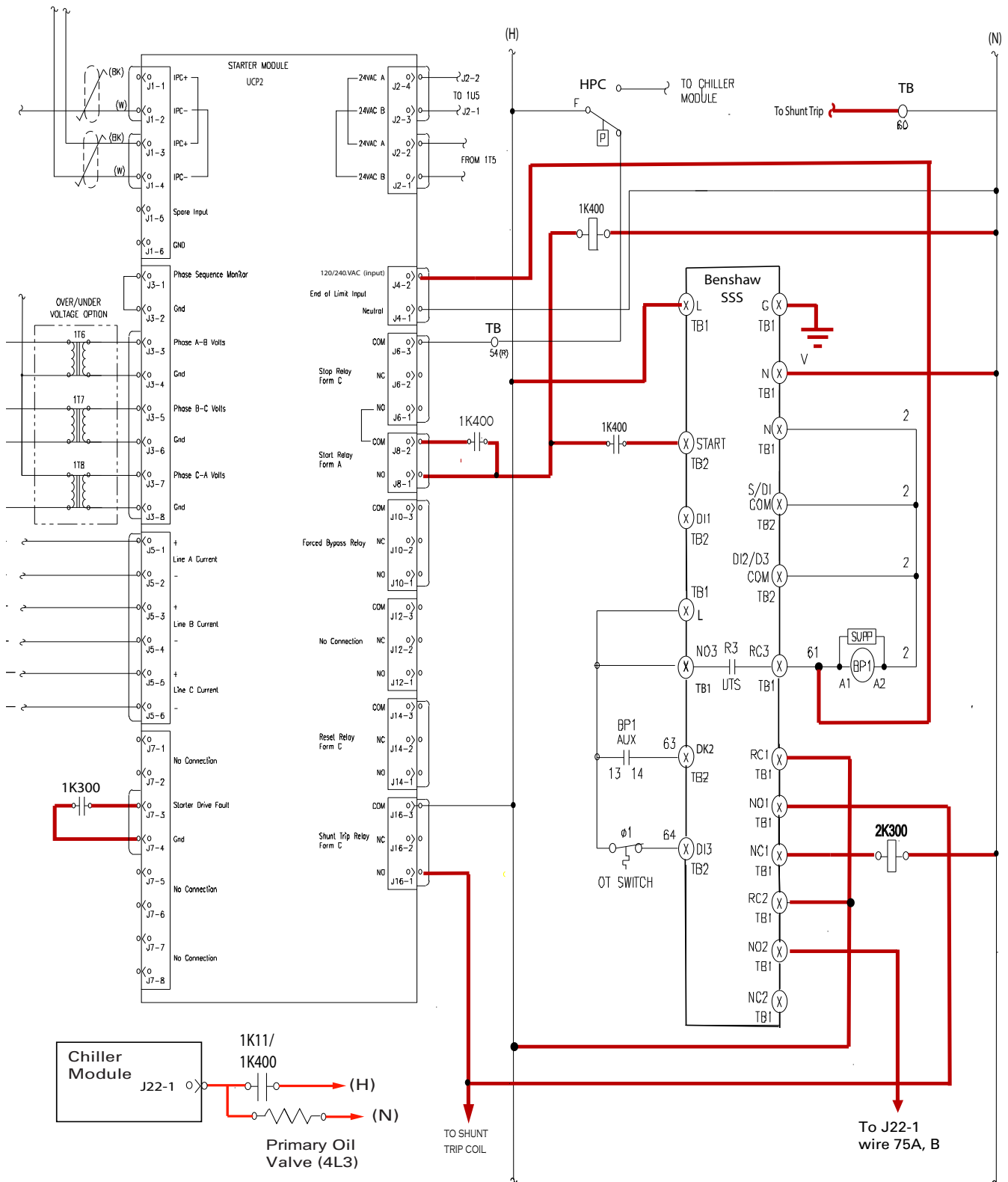

# RTHC Units with IT (or Wye-Delta) Starter

Figure 28. Control power wiring (new wiring bold/highlighted in red) — RTHC - MX2 starter

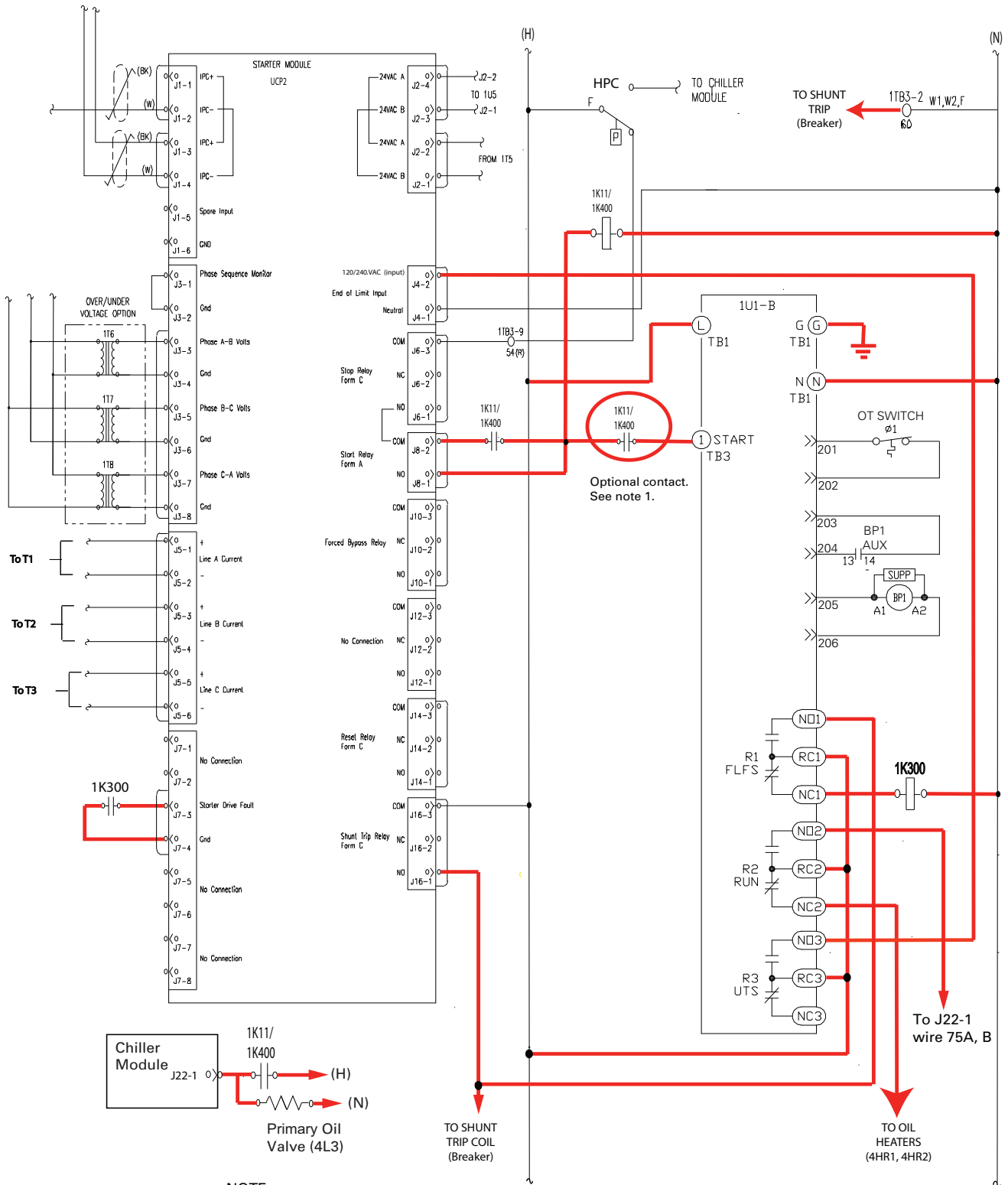
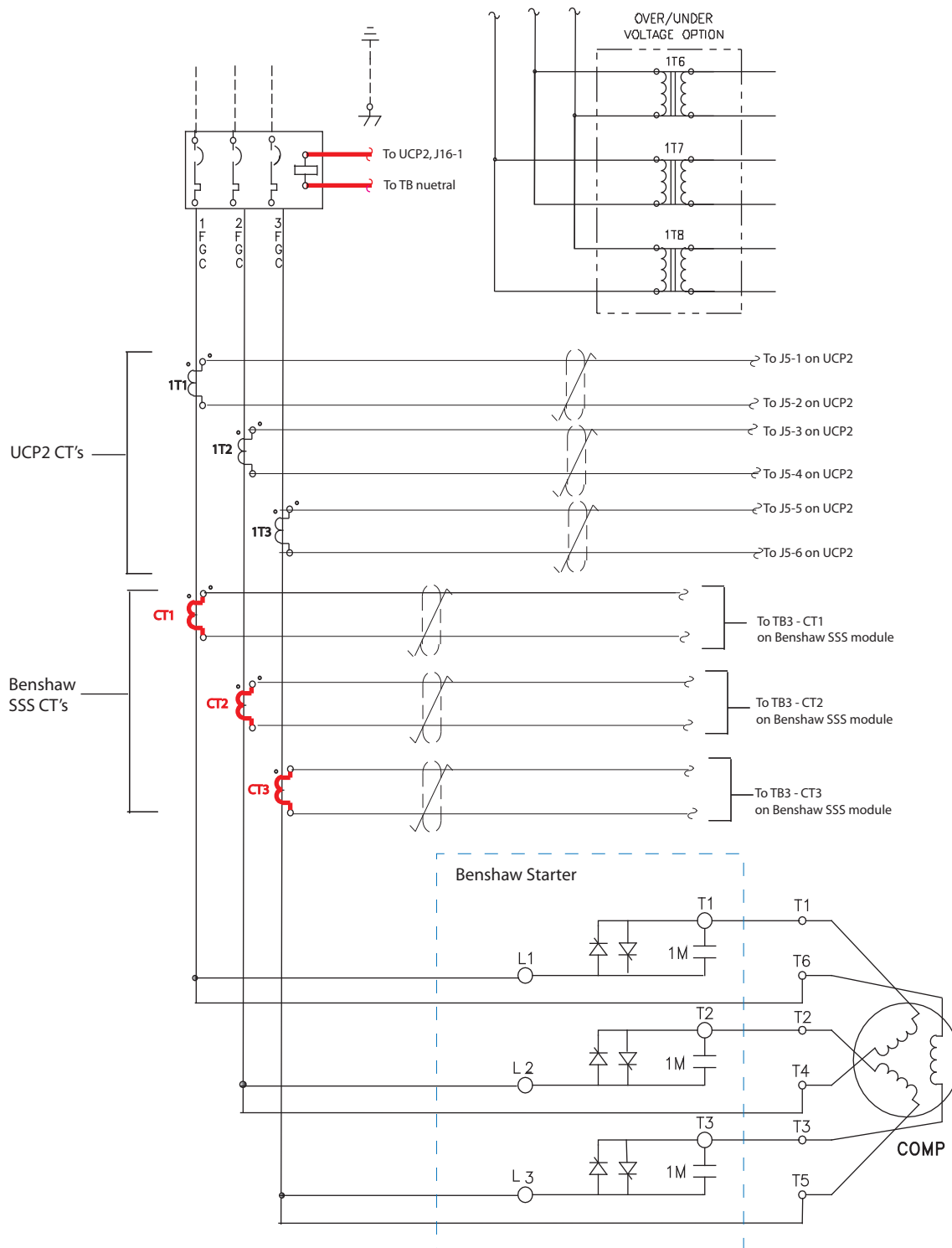

Figure 29. Power wiring (new wiring bold/highlighted in red)— RTHC



# RTHD Units with IT Starter

## Removal of Existing Starter

**⚠ WARNING**

**Hazardous Voltage w/Capacitors!**

Failure to disconnect power and discharge capacitors before servicing could result in death or serious injury. Disconnect all electric power, including remote disconnects and discharge all motor start/run capacitors before servicing. Follow proper lockout/tagout procedures to ensure the power cannot be inadvertently energized. For variable frequency drives or other energy storing components provided by Trane or others, refer to the appropriate manufacturer's literature for allowable waiting periods for discharge of capacitors. Verify with a CAT III or IV voltmeter rated per NFPA 70E that all capacitors have discharged.

The following components of an Intelligent Technology (IT)SSS need to be removed prior to installing the Benshaw RediStart starter:

- Intelligent Starter (IT)
- 1K11 (replace)

For units with wye-delta starters, remove the associated contactors and resistors. See ["RTHA Units with Wye-Delta Starters," p. 8](#) for an example.

[Figure 30, p. 32](#) shows the basic layout of the IT starter with the components that need to be removed highlighted.

Figure 30. Remove the highlighted components (IT starter) — RTHD

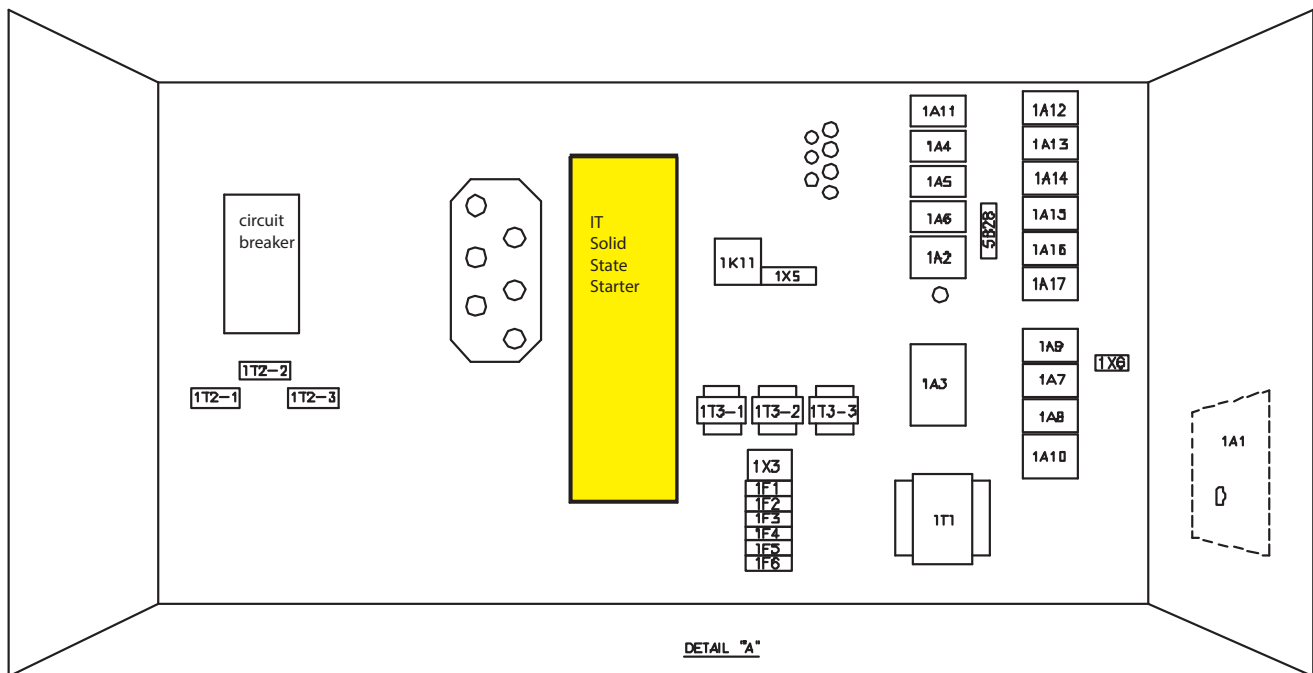



Figure 31. Photo of IT solid state starter (PFCC customer supplied) — RTHD

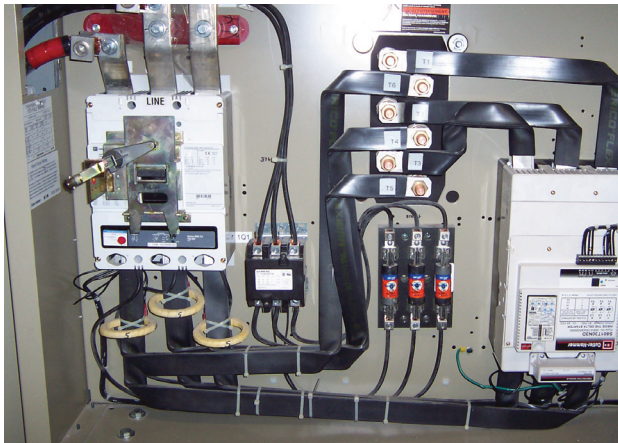
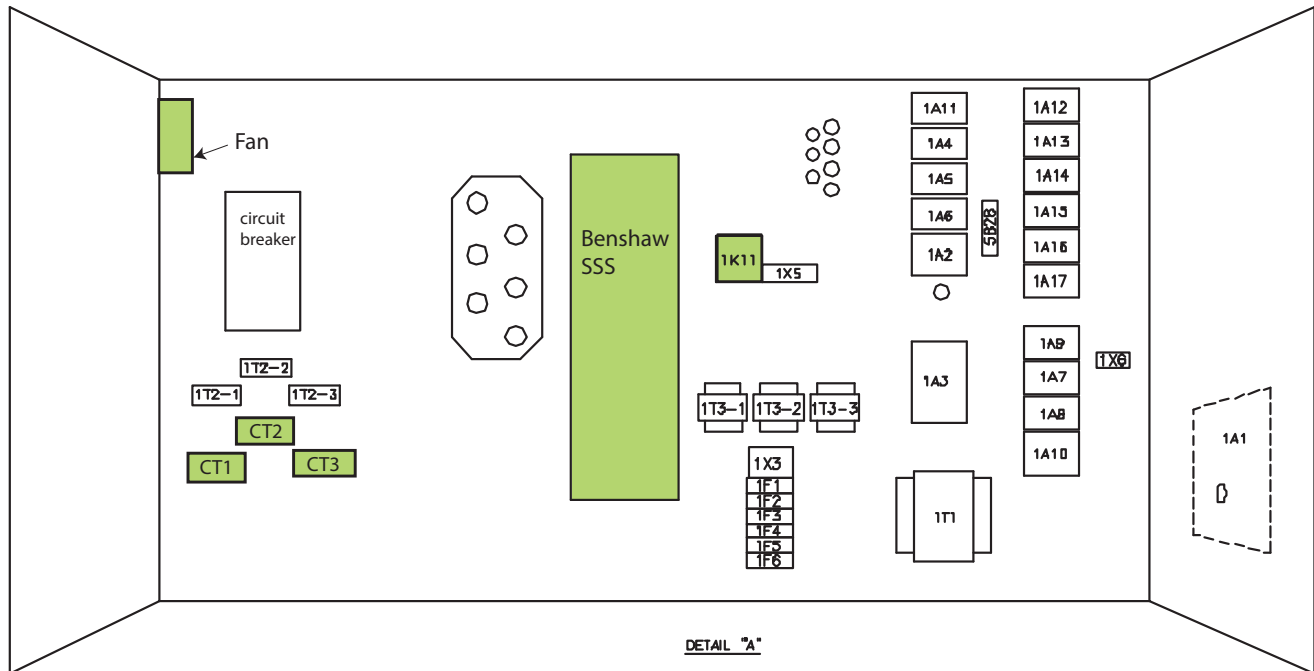

Figure 32. Location of benschaw starter — RTHD



## Installation of Benschaw Starter

Once the IT starter is removed, refer to [Figure 32, p. 33](#) for the approximate location of the new components.

The Benschaw Redistart SSS is supplied with current transformers. The current transformers wired to the chiller need to remain installed as shipped from the factory. The current transformers supplied with the solid state starter need to be installed as close to the original current transformers as possible for proper operation. See [Figure 36, p. 37](#) for proper installation location of the Benschaw current transformers.

*Benschaw CTs are polarity sensitive. For specific details on mounting of the Benschaw Solid State Starter, refer to the Benschaw Solid State Starter Hardware Manual pages 20-32. The manual ships with the Benschaw starters.*

## All Components Installed

To help visualize the routing of the wiring between the existing starter module, compressor terminals and Benshaw RediStart Solid State Starter, see the photograph in [Figure 33, p. 34](#)

**Figure 33. Benshaw starter installed — RTHD**

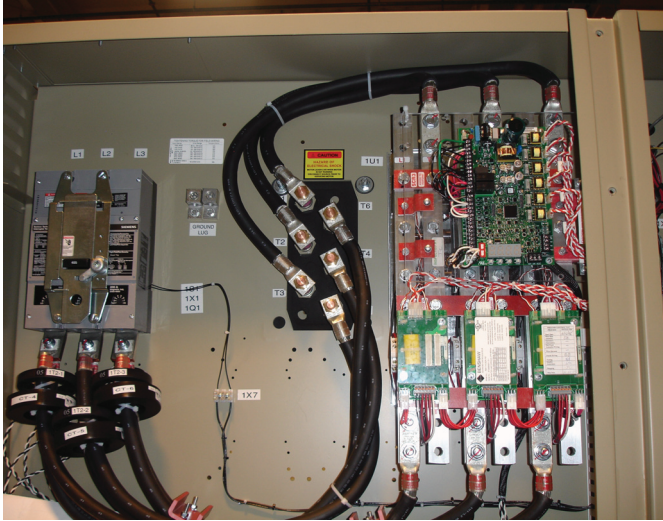

## Additional Components

See “[Additional Components](#),” p. 34 in General Information chapter for more information.

### Pilot Relays

Replace the 1K11. See [Table 8, p. 47](#) for part numbers.

## Wiring

### **⚠ WARNING**

#### **Hazardous Voltage w/Capacitors!**

Failure to disconnect power and discharge capacitors before servicing could result in death or serious injury. Disconnect all electric power, including remote disconnects and discharge all motor start/run capacitors before servicing. Follow proper lockout/tagout procedures to ensure the power cannot be inadvertently energized. For variable frequency drives or other energy storing components provided by Trane or others, refer to the appropriate manufacturer’s literature for allowable waiting periods for discharge of capacitors. Verify with a CAT III or IV voltmeter rated per NFPA 70E that all capacitors have discharged.

### **NOTICE**

#### **Starter Damage!**

Use of power factor correction or surge capacitors on the load side of the starter will result in serious damage to the starter that will NOT be covered by the starter warranty. The capacitors **MUST** be connected to the line side of the starter. The up-to-speed (UTS) contact can be used to energize the capacitors after the motor has reached full speed. Do **NOT** connect the capacitors between the starter and motor. See RTHC-SVD02\*-EN for further details.

### **Low Voltage**

The next step is the interconnecting wiring between the existing controls and the new Benshaw RediStart starter. [Figure 34, p. 35](#) is the basic schematic showing the necessary wiring for the MX starter. [Figure 35, p. 36](#) is the schematic for the MX2 starter. Use the same wire size that was used for the original wiring.

**Note:** 14 gauge wire is sufficient for most applications. Adhere to all state and local electrical codes.

### **High Voltage**

Wire the high voltage/power supply from the starter to the compressor. Remove the existing terminal block and use the specified Starter Power Leak Kit listed in [Table 7, p. 47](#). Follow the schematic shown in [Figure 36, p. 37](#)

Once all of the components are installed and wiring is complete, skip to “[Quick Start, Initial Parameters](#),” p. 38.

Figure 34. Control power wiring (new wiring bold/highlighted in red) — RTHD - MX starter

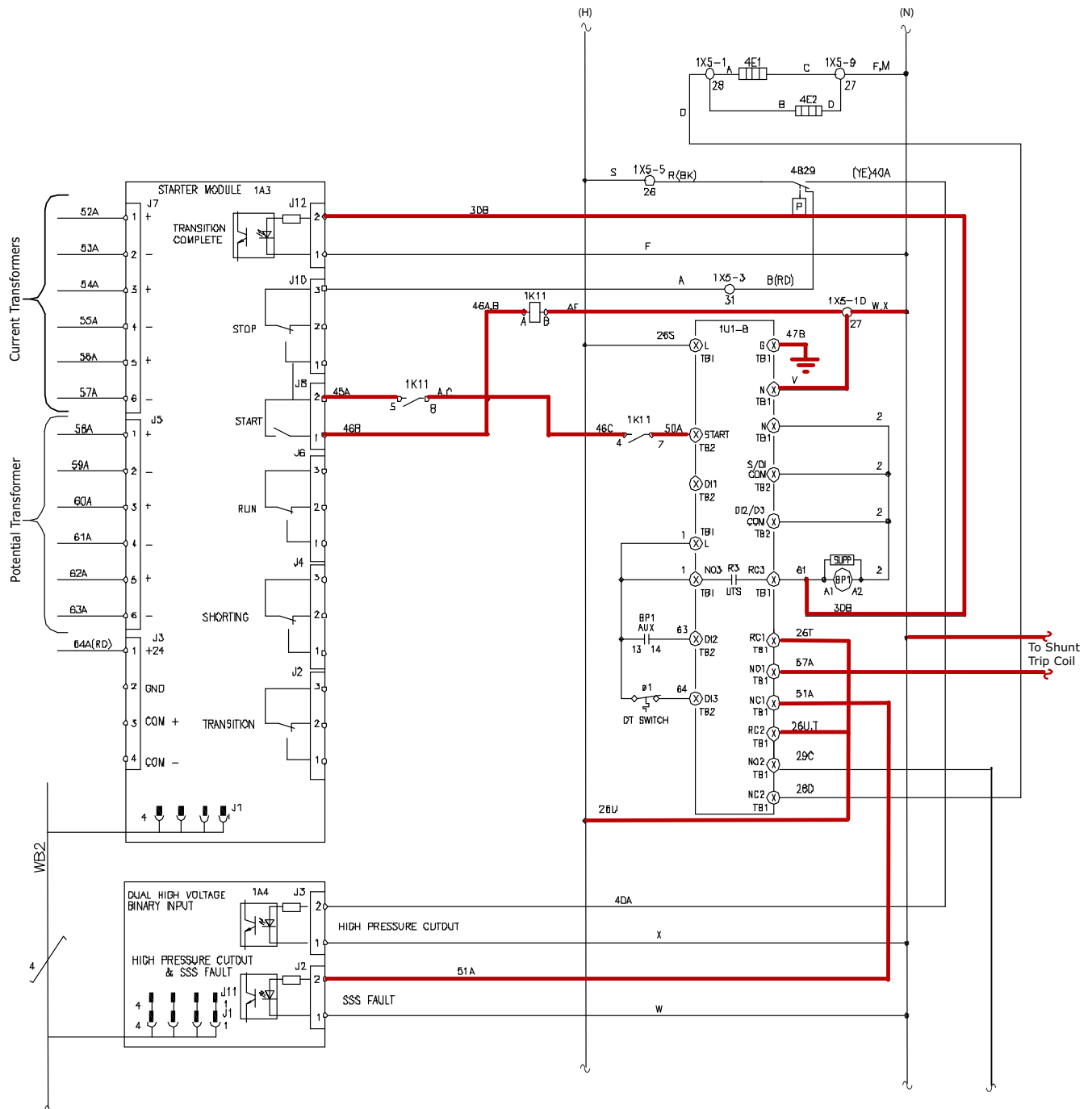
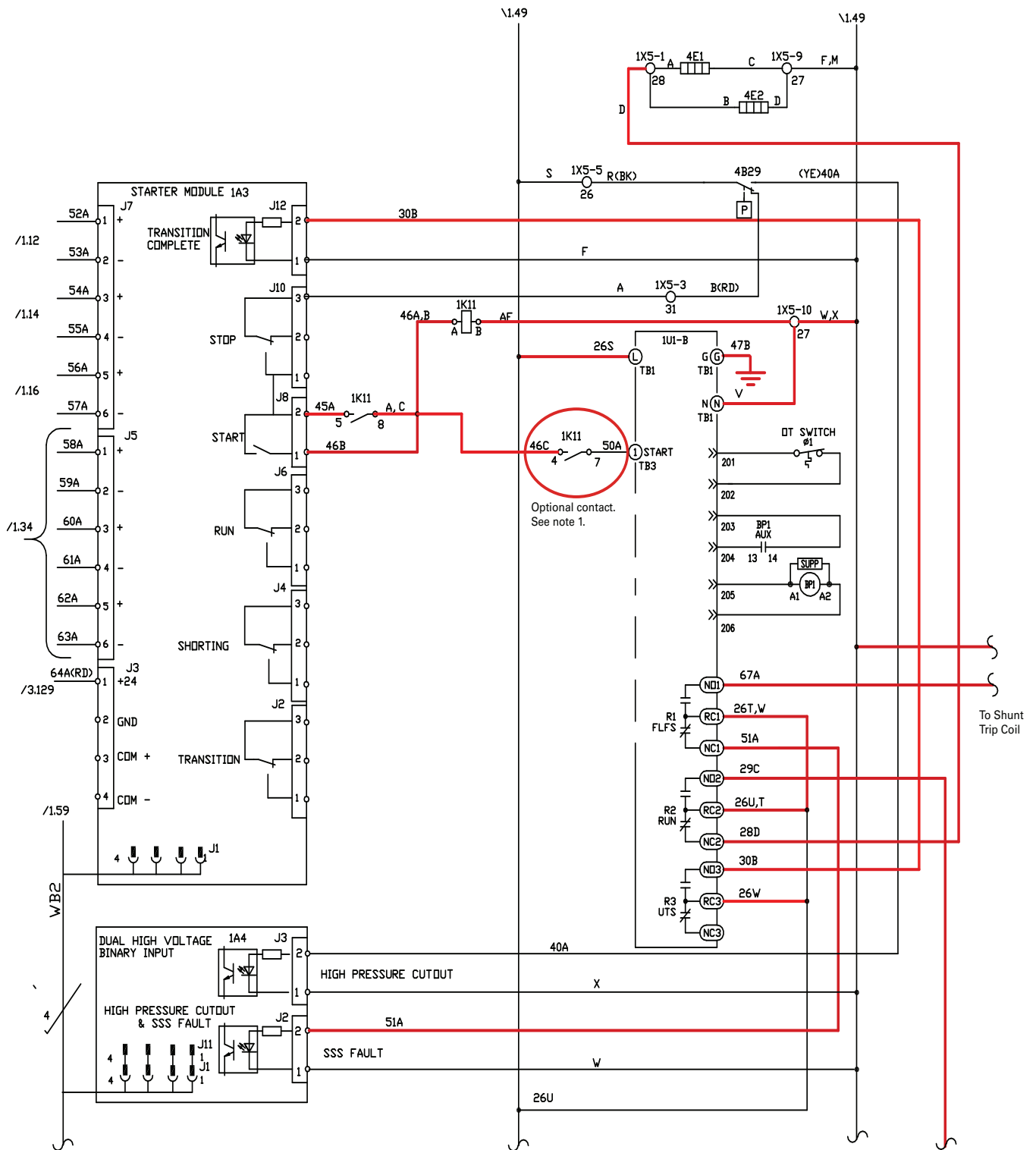

Figure 35. Control power wiring (new wiring bold/highlighted in red) — RTHD - MX2 starter



NOTE:

1. Connection to start signal is required. If you don't use this contact, you need to place a wire to the start signal.

Figure 36. Power wiring (new wiring bold/highlighted in red) — RTHD

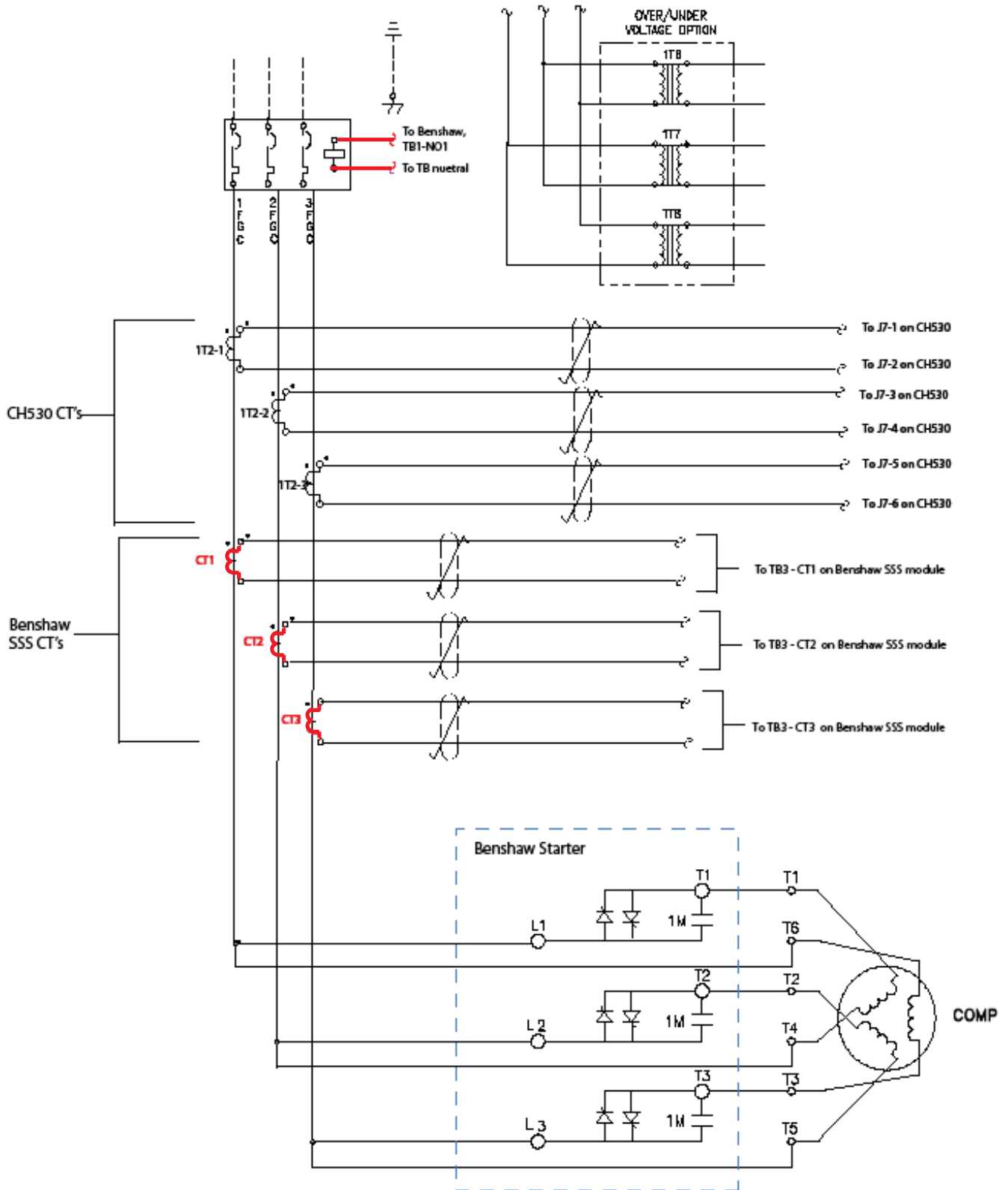



# Quick Start, Initial Parameters

**Important:** This chapter is only applicable for Trane starter software. It DOES NOT apply to MX2 STANDARD software starter. See Standard Benshaw MX2 Off-the-Shelf Software for use with Pueblo Chillers (Not applicable for Trane ONLY software MX/MX2 starters) - Programming Guide (RLC-SVP001\*-EN) for more information.

## Prior to Unit Power Up

**NOTICE**

**Compressor Motor Damage!**

Disconnect all electric power including remote disconnects prior to evacuating refrigeration. System power shall not be applied to the chiller while the refrigerant system is in a vacuum. Failure to disconnect power prior to evacuating the refrigerant system, or application of power while the refrigerant system is in a vacuum, will cause compressor motor damage due to the nature of the solid state starter.

Do NOT energize the unit if the refrigerant side of the system is in a vacuum.

The Benshaw Solid State Starter is an in-the-delta starter. The starter leads and motor leads are always energized. Catastrophic damage to the compressor motor will occur if supply power is applied while the system is in a vacuum.

## Programming UCP2 or CH530 Controller

**⚠ WARNING**

**Hazardous Voltage w/Capacitors!**

Failure to disconnect power and discharge capacitors before servicing could result in death or serious injury. Disconnect all electric power, including remote disconnects and discharge all motor start/run capacitors before servicing. Follow proper lockout/tagout procedures to ensure the power cannot be inadvertently energized. For variable frequency drives or other energy storing components provided by Trane or others, refer to the appropriate manufacturer's literature for allowable waiting periods for discharge of capacitors. Verify with a CAT III or IV voltmeter rated per NFPA 70E that all capacitors have discharged.

After the new starter is installed, the UCP2 or CH530 controller needs to be programmed.

- Programming of UCP2 or CH530 controller:
  - Disable the Phase Reversal Protection for proper unit operation. Phase reversal and phase loss protection is built into the Benshaw Redistart controller.

## Programming Benshaw Starter

The Benshaw controller on the solid state starter also needs to be programmed.

**Note:** Below is a limited guide for programming the Benshaw starter. See RediStart Solid State Starter RTHD Pueblo Built Units Only - Service and Diagnostic (RTHD-SVD02\*-EN) for further details on programming and troubleshooting the Benshaw starter.

In order for the starter to operate properly, the following parameters need to be validated before the starter can correctly start a motor. For the range of parameters, see parameter settings in Table 1, p. 39 and "CT Switch Settings," p. 40.

### P1 Motor FLA

This parameter configures the motor full load amps, and is obtained from the nameplate on the attached motor.

**Note:** Incorrectly setting this parameter will affect proper operation of the motor overload protection, motor over current protection, motor undercurrent protection, ground fault protection and acceleration control.

To set P1, start with the chiller RLA. If acceleration on start-up is sluggish, gradually increase the P1 setting. Do NOT exceed the RLA at Max kW. The unit RLA at max kW can be found in the product catalog or on the unit nameplate.

### P2 Maximum Motor Current

The maximum current parameter is set as a percentage of the motor FLA parameter setting. The maximum current parameter performs two functions. It sets the current level for the end of the ramp profile. It also sets the maximum current that is allowed to reach the motor after the ramp is completed. the maximum motor current is set to 260% from the factory.

If the ramp time expires before the motor has reached full speed, the starter will hold the current at the maximum current level until the UTS timer expires, the motor reaches full speed, or the overload trips.

**Note:** If faster acceleration is desired, the setting can be increased.

### P3 Ramp Time

The ramp time is the time it takes for the starter to allow the current to go from the initial current to the maximum current. To make the motor accelerate faster, decrease the ramp time. To make the motor accelerate slower, increase the ramp time.

The ramp time is set to 1 second from the factory.

If the ramp time expires before the motor reaches full speed, the starter will maintain the set maximum current level until either the motor reaches full speed, the UTS timer expires, or the motor thermal overload trips.

**Note:** Units built in Pueblo should not exceed 3 seconds. Setting the ramp time to a specific value does not necessarily mean that the motor will take this time to

*accelerate to full speed. The motor and load may achieve full speed before the ramp time expires if the application does not require the set ramp time and maximum current to reach full speed. Alternatively, the motor and load may take longer than the set ramp time to achieve full speed.*

### P4 Rated RMS Voltage

The Rated Voltage parameter sets the line voltage that is used when the starter performs Over and Under line voltage calculations. This value is the supply voltage; NOT the motor utilization voltage.

### P5 CT Ratio

The CT ratio must be set to match the CTs (current transformers) supplied with the starter. This allows the starter to properly calculate the current supplied to the motor.

Only Benschaw supplied CTs can be used on the starter. The CTs are custom 0.2 amp secondary CTs specifically designed for use on the MX starter. The CT ratio is then normalized to a 1A secondary value. The supplied CT ratio can be confirmed by reading the part number on the CT label. The part number is of the form BICTxxx1M, where xxx is the CT primary and the 1 indicates the normalized 1 amp.

**Note:** See *“Current Transformer Set-up (MX Only),” p. 40.*

### P6 Software Part Number

The software part number is useful for future service reasons. If calling Benschaw for service, this number should be recorded so it can be provided to the service technician.

On power up with an LED display, the software version is flashed one character at a time on the least significant digit. With an LCD display, the software PN is fully displayed on power up.

### P7 Passcode

The MX control supports a 4-digit passcode. When the passcode is set, parameters may not be changed.

When a passcode is set and an attempt is made to change a parameter through the display/keypad, the UP and DOWN keys will simply have no effect. When a passcode is set and an attempt is made to change a parameter through Modbus, the control will return an error response with an exception code of 03 (Illegal Data Value) to indicate that the register may not be changed.

### P8 Fault Log

When a fault occurs, the fault number is logged in non-volatile memory. The most recent fault will be in FL1 location and the oldest fault will be in FL9.

See *“Troubleshooting,” p. 42* or *RediStart Solid State Starter RTHD Pueblo Built Units Only - Service and Diagnostic (RTHD-SVD02\*-EN) Appendix* for the fault codes and their descriptions.

## Parameter Settings

**Important:** Information in [Table 1](#) is parameter setting for Benschaw Trane ONLY software. These are NOT the **STANDARD** MX2 parameter settings.

**Table 1. Parameter settings MX/MX2 — Trane ONLY software**

Parameter	Description	Setting Range	Units	Default
P1	Motor FLA	1-6400	A <sub>rms</sub>	10
P2	Maximum Motor Current	100-800	%FLA	260
P3	Ramp Time	0-300	Sec	1
P4	Rated RMS Voltage	200, 208, 220, 230, 240, 350, 380, 400, 415, 440, 460, 480, 500, 525, 575, 600	V <sub>rms</sub>	480
P5	CT Ratio (x:1)	2640, 5760	-	2640
P6	Software Part Number	Display only	-	-
P7	Passcode	0-9999	-	-
P8	Fault Log	Display faults stored in Fault log	-	-



**Current Transformer Set-up (MX Only)**

**CT Switch Settings**

When the starter is shipped from the factory, CT settings are set to match CT ratios supplied with the starter. If the MX control is changed the CT settings must be changed to match the CT ratios for that given current rating.

To verify or change the motor current signal scaling:

- Compare the CT ratio stamped on each CT to the CT ratio listed on the wiring diagram supplied with the starter to ensure the correct CTs are installed.
- Inspect the control card to ensure that the DIP switches are in the correct positions for the applicable CT ratio and the motor full-load current (FLA).

**Table 2. CT switch settings**

CT Ratio	Minimum FLA (Arms)	Maximum FLA (Arms)	Switch 6 Position 1	Switch 6 Position 2
2640	73	128	Off	Off
	128	151	Off	On
	151	330	On	Off
	330	590	On	On
5760	590	720	On	Off
	720	1280	On	On

**CT Polarity (MX and MX2)**

CT has a polarity that must be correct for starter to accurately measure Watts, kW Hours, Power Factor, and for Power and TruTorque motor control functions to operate properly.

Each CT has a dot on one side of flat surfaces. The dot, normally white, must be facing in direction of the line.

The CT can be placed either before or after the starter. In specific applications, like Inside Delta, the CT's must be before the starter.

CT1 must be on Line L1 (R), CT2 must be on Line L2 (S), CT3 must be on Line L3 (T).

**Figure 37. RTHB - Installation of CTs**

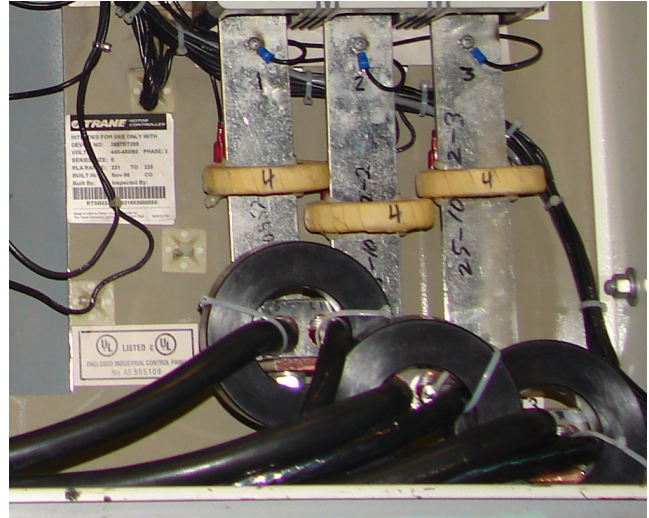

**Figure 38. RTHC - Installation of CTs**



**Figure 39. RTHD - Installation of CTs**







# Remote Keypad

## Meeting NFPA 70

A remote keypad for the Benshaw Redistart is available. In some instances, the remote keypad can be used to meet NFPA 70 guidelines for arc flash protection.

The remote keypad has several features some of which are listed below:

- Allows plain language programming
- View Status Information (accelerating, running - up to speed, stopping, etc.)
- Set / Examine operating parameters
- Detailed plain language fault information to the last nine faults including;
  - Fault Description
  - Status when fault occurred (run, stopped, etc.)
  - Current in each phase when fault occurred
  - Voltage in each phase when fault occurred
  - Kw when fault occurred
  - Frequency when fault occurred
  - Run time since last reset occurred
- Metering +/- 2% accuracy for the following
  - Average Current
  - L1 Current
  - L2 Current
  - L3 Current
  - Current Imbalance%
  - Ground Fault Amps / residual
  - Average Voltage
  - L1-L2 Voltage
  - L2-L3 Voltage
  - L3-L1 Voltage
  - Overload%
  - Power Factor
  - Watts
  - Var's
  - KW Hours
  - MW Hours
  - Phase Order
  - Line Frequency
  - Run Time - Days or Hours
  - Number of Starts
  - Peak Starting Current
  - Last Start Duration (accelerating)

See "Parts Ordering," p. 43 for appropriate part numbers.

**Figure 40. Benshaw remote keypad MX/MX2**



**Note:** See Benshaw User Guide #890034-01-00 for complete details on the remote keypad.



# Troubleshooting

**Table 3. Troubleshooting chart**

Description of the Problem	Possible Causes
Chiller starts but only runs for a few seconds.	Typically caused from a mis-wire of the low voltage.
Compressor starts immediately when power is applied.	Start command of the Benshaw Redistart wired incorrectly directly to 120 Vdc.
Compressor starts, runs less than 10 seconds and CH530 shuts down on a Phase Reversal diagnostic.	CH530 not programmed correctly. Disable Phase Reversal in CH530 controller.
While chiller is in Auto mode and compressor is off the shunt trip opens locking out compressor.	Troubleshoot the Benshaw SSS using RTHD-SVD02*-EN. Possible problem with SCR.
Shunt trips opens on compressor start.	P1 setting of Benshaw starter set incorrectly. Remove power to the unit and reprogram all P parameters of the Benshaw starter. (To program starter, apply external 120V to logic modules.) Faulty shunt trip.

**Note:** See Troubleshooting guides RTHD-SVD02\*-EN and RLC-SVD06\*-EN for more information.



# Parts Ordering

## ⚠ WARNING

### Hazardous Voltage w/Capacitors!

Failure to disconnect power and discharge capacitors before servicing could result in death or serious injury. Disconnect all electric power, including remote disconnects and discharge all motor start/run capacitors before servicing. Follow proper lockout/tagout procedures to ensure the power cannot be inadvertently energized. For variable frequency drives or other energy storing components provided by Trane or others, refer to the appropriate manufacturer's literature for allowable waiting periods for discharge of capacitors. Verify with a CAT III or IV voltmeter rated per NFPA 70E that all capacitors have discharged.

This manual is informational only and does not authorize any parts or labor.

## Selecting New Starter

To select the appropriate starter, record the unit nameplate RLA and determine the applications withstand rating. See [Table 4](#).

**Note:** For further information on the Benshaw Redistart starters, refer to Benshaw Redistart SSS Hardware Manual #890023-02-01. **Higher amp rated starters are available upon request.** Contact Technical Support or the local Trane parts center for further details.

**Table 4. Solid state starter panel**

Unit Nameplate RLA	Trane Part Number Standard MX2	Starter Withstand Rating (KA)	Fault Rating	Starter Description <sup>(a)</sup> Trane Software MX2 (MX)
1-207	STR01497	30	High	RB2-1-H-125A-14C (RBX-1-H-125A-14C)
208-300	STR01498	30	High	RB2-1-H-180A-14C (RBX-1-H-180A-14C)
301-397	STR01499	65	High	RB2-1-H-240A-14C (RBX-1-H-240A-14C)
398-476	STR01500	65	High	RB2-1-H-302A-14C (RBX-1-H-302A-14C)
501-598	STR01501	65	High	RB2-1-H-361A-14C (RBX-1-H-361A-14C)

**Note:** For further information on the Benshaw Redistart starters refer to Benshaw Redistart SSS Hardware Manual #890023-02-01". Higher amp rated starters are available upon request. Contact technical support or the local Trane parts center for further details. In the Delta RLA = (unit nameplate RLA)\*1.05/1.15/1.55

(a) Digit 5 indicates Std (S) or High (H) interrupt rating. Digits 6-8 indicated amp rating of in the delta starter.

# Mounting Dimensions

## Max Starter

Figure 41. Dimensional drawing of benschaw solid state starter

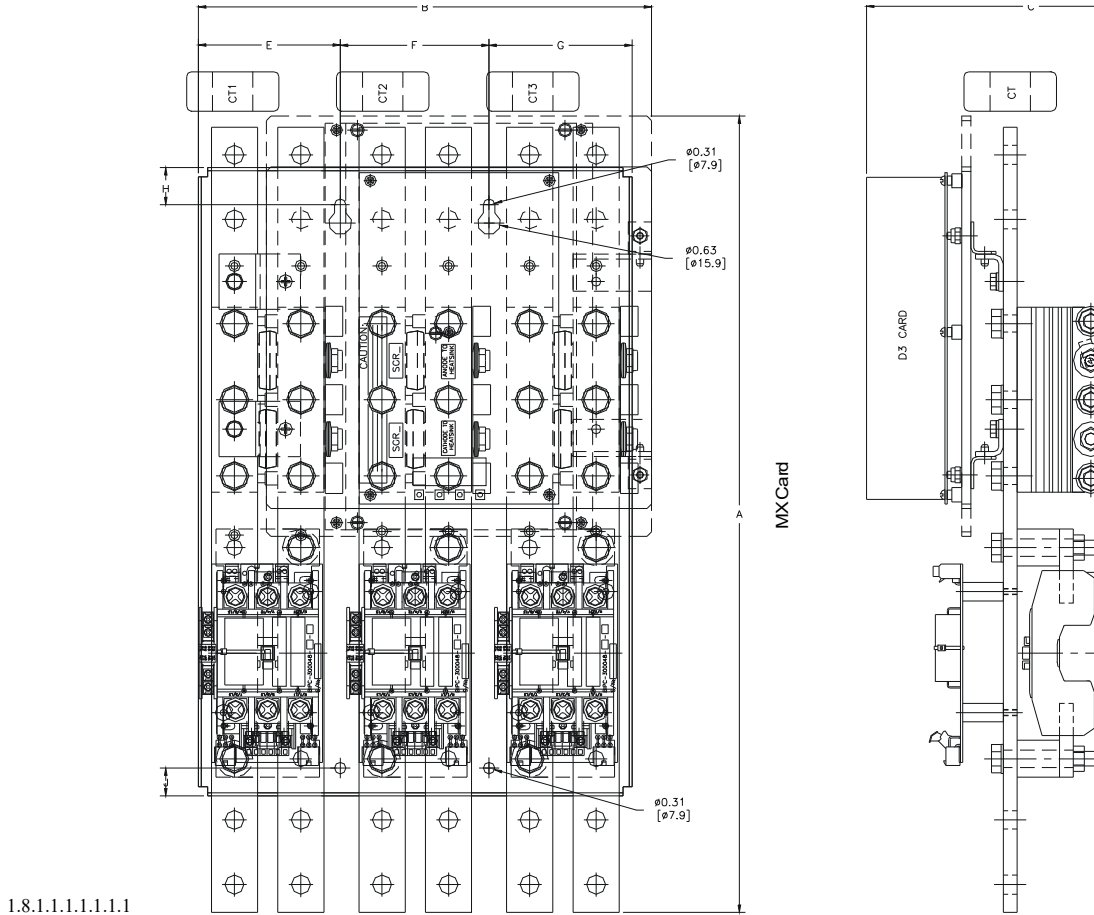

Table 5. Mounting dimensions for benschaw starter

AMP	Frame Size	A in (mm)	B in (mm)	C in (mm)	D in (mm)	E in (mm)	F in (mm)	G in (mm)	H in (mm)	J in (mm)	Weight lbs (kg)
125-180	14	19.80 (205.92)	12.27 (311.8)	8.91 (226.3)	17.00 (431.8)	3.88 (98.5)	4.00 (101.5)	3.88 (98.5)	1.00 (25.4)	0.75 (19.1)	43 (19.5)
180	14	21.55 (547.4)	12.27 (311.8)	8.91 (226.3)	17.00 (431.8)	3.88 (98.5)	4.00 (101.5)	3.88 (98.5)	1.00 (25.4)	0.75 (19.1)	43 (19.5)
180-302	15	22.00 (558.8)	12.27 (311.8)	9.16 (232.6)	18.5 (469.9)	3.88 (98.5)	4.00 (101.5)	3.88 (98.5)	1.00 (25.4)	0.75 (19.1)	51 (23.1)
361	16	23.87 (606.2)	12.90 (327.6)	9.16 (232.6)	20.25 (514.4)	4.03 (102.4)	4.31 (109.5)	4.03 (102.4)	1.00 (25.4)	0.75 (19.1)	56 (25.4)

**Note:** Mounting holes: Keyhole: 0.31 x 0.63 (7.87 x 15.88)  
 Bottom: 0.31 (7.87)  
 Amp rating in the first column is the in the delta amp rating. This rating is noted in the starter description number digits 6th-8th.  
 In The Delta RLA = Unit nameplate RLA \* 1.05 / 1.15 / 1.55

## MX2 Starter Dimensions

Figure 42. MX2 dimensions

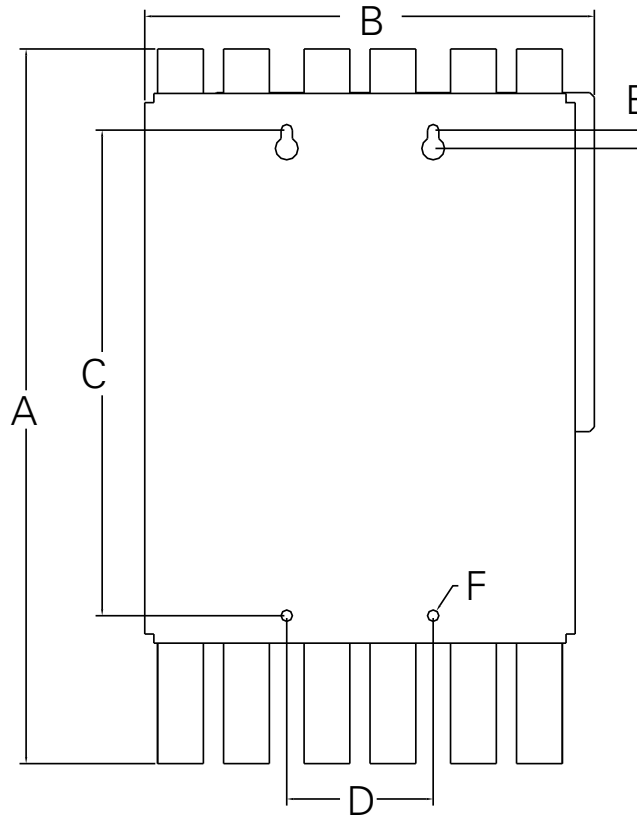
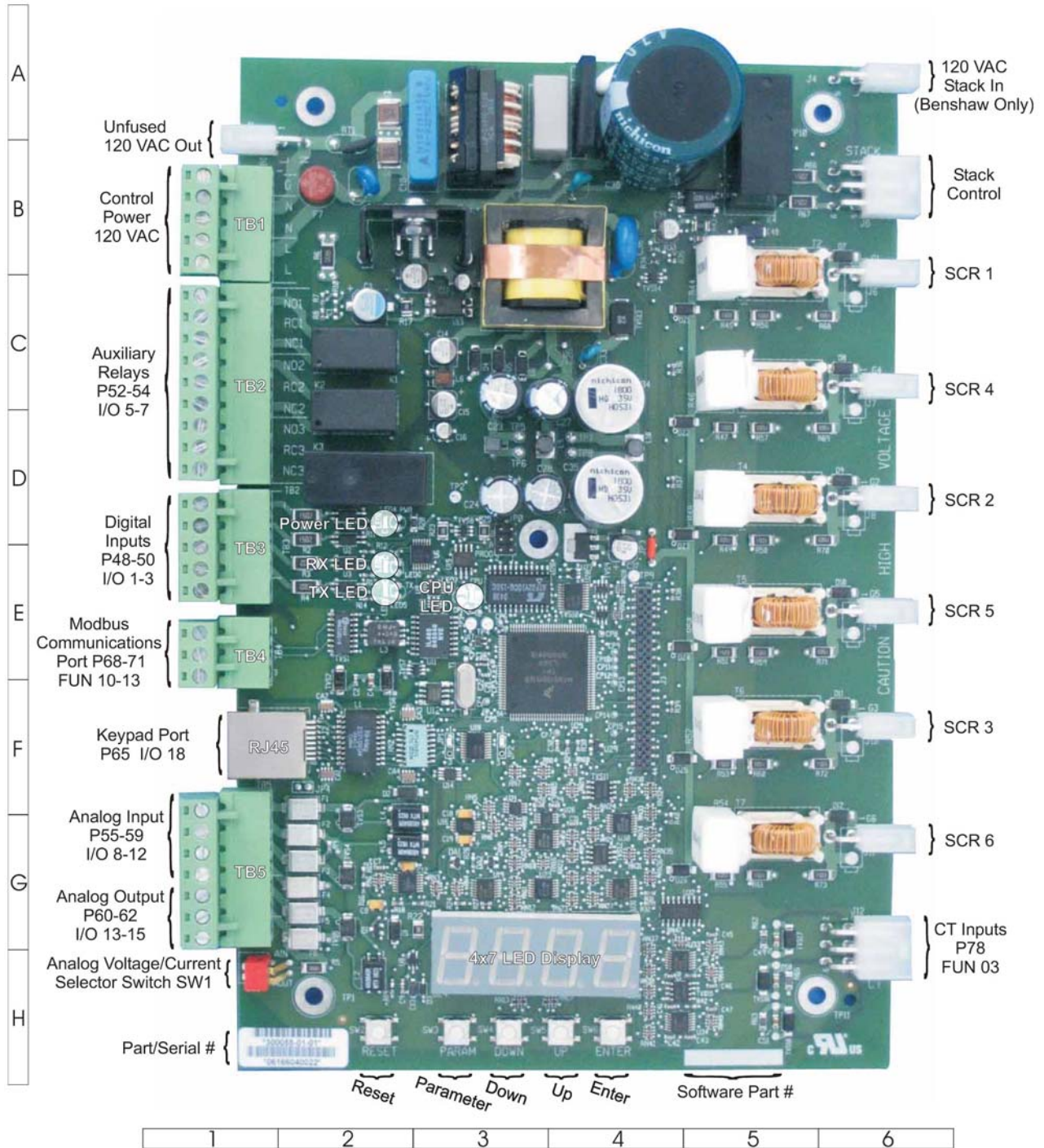

Table 6. MX2 dimensions - in (mm)

Model	A	B	C	D	E	F
RB2 125A	19.5 (495)	12.27 (312)	13.25 (337)	4 (101.6)	0.5 (12.7)	0.31 (7.9)
RB2 156-180A	21.25 (540)	12.27 (312)	15.25 (387)	4 (101.6)	0.5 (12.7)	0.31 (7.9)
RB2 180-302A	22.75 (578)	12.27 (312)	16.75 (425)	4 (101.6)	0.5 (12.7)	0.31 (7.9)
RB2 361A	23.87 (606)	13.09 (332)	18.63 (473)	4.31 (109)	0.5 (12.7)	0.31 (7.9)

Figure 43. MX2 board layout





## Starter Power Leads

The power leads traveling from the incoming power lines to the solid state starter panel and then from the solid state starter panel to the compressor motor terminals can be obtained locally or ordered from Trane Service Parts.

Two wiring kits are necessary for each unit.

**Table 7. Starter power lead kits**

Unit Type	Max Panel RLA	Kits
RTHA/RTHB	0-300 amps (130-150 ton ONLY)	WIR04920 and WIR04924 (motor terminal lugs - 3/8")
	0-300 amps (180 ton and larger)	WIR04919 and WIR04923 (motor terminal lugs - 5/8")
	301-476 amps	WIR04918 and WIR04922
	477-598/500 amps	WIR04917 and WIR04921
RTHC	0-300 amps	WIR04927 and WIR04930
	301-476 amps	WIR04926 and WIR04929
	477-598/500 amps	WIR04925 and WIR04928
RTHD	0-207 amps	WIR04833 and WIR04838
	208-300 amps	WIR04832 and WIR04837
	301-397 amps	WIR04831 and WIR04836
	398-476 amps	WIR04830 and WIR04835
	477-598/500 amps	WIR04829 and WIR04834

## Circuit Breaker with Shunt Trip

The Benshaw solid state starter requires a shunt trip circuit breaker. If the existing starter has a circuit breaker without a shunt trip device, either a shunt trip element needs to be added to the circuit breaker or the circuit breaker needs to be upgraded to include a shunt trip device. The addition of the shunt trip circuit breaker/device may require some mechanical modifications to the cabinet.

## Additional Components

Some additional components are necessary for proper operation. Refer to each specific unit section to determine which additional components are necessary.

**Table 8. Additional components**

Part Description	Part Number
Cabinet Fan	FAN03692
Pilot Relay 2K300, 1K300, 2K400, 1K400, 1K11	RLY02467
Shunt Trip (Breaker)	Required with all Benshaw SSS. Contact Trane Service Parts or select and obtain locally per state and local NEC codes.
Remote SSS display	BRD03541 KPMX3CBL2M MX2: NEMA 4 Remote Keypad with 2 m Cable
	BRD03599 MX-2M-RKO-00 MX: NEMA 4 Remote Keypad with 2 m Cable
CAUTION safety label	LBL00419 (Qty 2/unit required)

**Note:** Secure locally any required low voltage wire, bolts, nuts and other hardware as required.

## Service Components

In the event of an MX logic module failure, the MX logic module is NO LONGER AVAILABLE. See Table 9 for information on MX-to-MX2 logic module conversion.

**Table 9. Service components**

Part Description	Part Number
Kit - MX2 Logic Module Conversion	KIT16751

## Production Change

All units ordered with a solid state starter after February 2005 were manufactured with the Benshaw Redistart Solid State Starter.

## Questions

Contact the Product Technical Service department in Pueblo, Colorado with questions regarding this Installation Guide. They can be contacted at [techservicepueblo@trane.com](mailto:techservicepueblo@trane.com).

Trane - by Trane Technologies (NYSE: TT), a global climate innovator - creates comfortable, energy efficient indoor environments for commercial and residential applications. For more information, please visit [trane.com](https://trane.com) or [tranetechnologies.com](https://tranetechnologies.com).

Trane has a policy of continuous product and product data improvement and reserves the right to change design and specifications without notice. We are committed to using environmentally conscious print practices.