

Installation, Operation, and Maintenance Foundation™ Packaged Rooftop Units

Cooling and Gas/Electric
7.5 to 12.5 Tons, 60 Hz

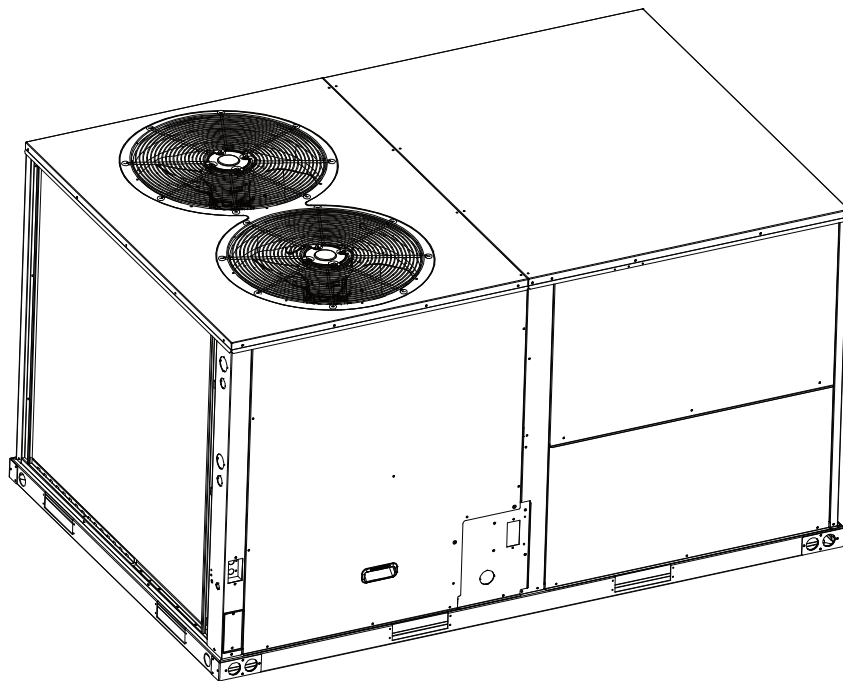

Model Numbers: EDK090-150, GDK090-150

▲ SAFETY WARNING

Only qualified personnel should install and service the equipment. The installation, starting up, and servicing of heating, ventilating, and air-conditioning equipment can be hazardous and requires specific knowledge and training. Improperly installed, adjusted or altered equipment by an unqualified person could result in death or serious injury. When working on the equipment, observe all precautions in the literature and on the tags, stickers, and labels that are attached to the equipment.

October 2024

RT-SVX096A-EN

Introduction

Read this manual thoroughly before operating or servicing this unit.

Warnings, Cautions, and Notices

Safety advisories appear throughout this manual as required. Your personal safety and the proper operation of this machine depend upon the strict observance of these precautions.

The three types of advisories are defined as follows:



Indicates a potentially hazardous situation which, if not avoided, could result in death or serious injury.



Indicates a potentially hazardous situation which, if not avoided, could result in minor or moderate injury. It could also be used to alert against unsafe practices.

NOTICE

Indicates a situation that could result in equipment or property-damage only accidents.

Important Environmental Concerns

Scientific research has shown that certain man-made chemicals can affect the earth's naturally occurring stratospheric ozone layer when released to the atmosphere. In particular, several of the identified chemicals that may affect the ozone layer are refrigerants that contain Chlorine, Fluorine and Carbon (CFCs) and those containing Hydrogen, Chlorine, Fluorine and Carbon (HCFCs). Not all refrigerants containing these compounds have the same potential impact to the environment. Trane advocates the responsible handling of all refrigerants.

Important Responsible Refrigerant Practices

Trane believes that responsible refrigerant practices are important to the environment, our customers, and the air conditioning industry. All technicians who handle refrigerants must be certified according to local rules. For the USA, the Federal Clean Air Act (Section 608) sets forth the requirements for handling, reclaiming, recovering and recycling of certain refrigerants and the equipment that is used in these service procedures. In addition, some states or municipalities may have additional requirements that must also be adhered to for responsible management of refrigerants. Know the applicable laws and follow them.

WARNING

Proper Field Wiring and Grounding Required!

Failure to follow code could result in death or serious injury.

All field wiring MUST be performed by qualified personnel. Improperly installed and grounded field wiring poses FIRE and ELECTROCUTION hazards. To avoid these hazards, you MUST follow requirements for field wiring installation and grounding as described in NEC and your local/state/national electrical codes.

WARNING

Personal Protective Equipment (PPE) Required!

Failure to wear proper PPE for the job being undertaken could result in death or serious injury.

Technicians, in order to protect themselves from potential electrical, mechanical, and chemical hazards, **MUST follow precautions in this manual and on the tags, stickers, and labels, as well as the instructions below:**

- **Before installing/servicing this unit, technicians MUST put on all PPE required for the work being undertaken (Examples; cut resistant gloves/sleeves, butyl gloves, safety glasses, hard hat/bump cap, fall protection, electrical PPE and arc flash clothing). ALWAYS refer to appropriate Safety Data Sheets (SDS) and OSHA guidelines for proper PPE.**
- **When working with or around hazardous chemicals, ALWAYS refer to the appropriate SDS and OSHA/GHS (Global Harmonized System of Classification and Labelling of Chemicals) guidelines for information on allowable personal exposure levels, proper respiratory protection and handling instructions.**
- **If there is a risk of energized electrical contact, arc, or flash, technicians MUST put on all PPE in accordance with OSHA, NFPA 70E, or other country-specific requirements for arc flash protection, PRIOR to servicing the unit. NEVER PERFORM ANY SWITCHING, DISCONNECTING, OR VOLTAGE TESTING WITHOUT PROPER ELECTRICAL PPE AND ARC FLASH CLOTHING. ENSURE ELECTRICAL METERS AND EQUIPMENT ARE PROPERLY RATED FOR INTENDED VOLTAGE.**

⚠ WARNING**Follow EHS Policies!**

Failure to follow instructions below could result in death or serious injury.

- All Trane personnel must follow the company's Environmental, Health and Safety (EHS) policies when performing work such as hot work, electrical, fall protection, lockout/tagout, refrigerant handling, etc. Where local regulations are more stringent than these policies, those regulations supersede these policies.
- Non-Trane personnel should always follow local regulations.

⚠ WARNING**R-454B Flammable A2L Refrigerant!**

Failure to use proper equipment or components as described below could result in equipment failure, and possibly fire, which could result in death, serious injury, or equipment damage.

The equipment described in this manual uses R-454B refrigerant which is flammable (A2L). Use ONLY R-454B rated service equipment and components. For specific handling concerns with R-454B, contact your local representative.

⚠ WARNING**Electrical Shock Hazard!**

Failure to follow instructions below could result in death or serious injury.

Properly connect the system's oversized protective earthing (grounding) terminal(s).

⚠ WARNING**Hazard of Explosion or Fire!**

Failure to follow instructions could result in death or serious injury and equipment or property damage.

Do not store or use gasoline or other flammable vapors and liquids in the vicinity of this or any other appliance.

IF YOU SMELL GAS, follow instructions below:

- Do not try to light any appliance.
- Do not touch any electrical switch.
- Do not use any phone in your building.
- Open windows and doors.
- Alert others and evacuate building immediately.
- From a phone outside of the building, immediately call your gas supplier. Follow the gas supplier's instructions. If you cannot reach your gas supplier, call the fire department.

⚠ WARNING**Leak Detection System Installed!**

Failure to follow instructions below could result in death or serious injury or equipment damage.

The unit is equipped with electrically powered safety measures and must be powered at all times after installation, except during servicing, to detect any leak.

⚠ WARNING**Safety Hazard!**

Failure to follow instructions below could result in death or serious injury and equipment or property damage.

- Do not use any items other than those approved by the manufacturer for defrosting or cleaning process.
- Store the appliance in a room without continuously operating ignition sources (for example: open flames, an operating gas appliance, or an operating electric heater).
- Do not pierce or burn.
- Be cautious that refrigerants may be odorless.

Overview of Manual

One copy of this document ships inside the control panel of each unit and is customer property. It must be retained by the unit's maintenance personnel.

Important: Do not release refrigerant to the atmosphere! If adding or removing refrigerant is required, the service technician must comply with all federal, state, and local laws.

This booklet describes the proper installation, start-up, operation, and maintenance procedures for air cooled systems.

By carefully reviewing the information within this manual and following the instructions, the risk of improper operation and/or component damage will be minimized.

It is important that periodic maintenance be performed to help assure trouble free operation. A maintenance schedule is provided at the end of this manual. Should equipment failure occur, contact a qualified service organization with qualified, experienced HVAC technicians to properly diagnose and repair this equipment.

Copyright

This document and the information in it are the property of Trane, and may not be used or reproduced in whole or in part without written permission. Trane reserves the right to revise this publication at any time, and to make changes to its content without obligation to notify any person of such revision or change.

Trademarks

All trademarks referenced in this document are the trademarks of their respective owners.

Factory Training

Factory training is available through Trane University™ to help you learn more about the operation and maintenance of your equipment. To learn about available training opportunities contact Trane University™.

Online: www.trane.com/traneuniversity

Email: traneuniversity@trane.com

Product Safety Information

This appliance is not intended for use by persons (including children) with reduced physical, sensory or mental capabilities, or lack of experience and knowledge, unless they have been given supervision or instruction concerning use of the appliance by a person responsible for their safety. Children should be supervised to ensure that they do not play with the appliance.

Maximum altitude of use 3000 meters.

This appliance incorporates an earth connection for functional purposes only.

Table of Contents

Model Number Description	7	Electrical Phasing (Three Phase Motors)	29
General Information	8	Checklist	30
Overview of Manual	8	External Unit Power Supply	30
Unit Inspection	8	Unit Disconnect Wiring Plan	30
Exterior Inspection	8	Through-the-Base Gas Utility Option	31
Inspection for Concealed Damage	8	Field Installed Connections	31
Unit Storage	8	Refrigerant Sensor	32
Unit Description	9	Pre Start	34
System Input Devices and Functions	9	Verifying Proper Air Flow (Units with Belt Drive Indoor Fan)	34
Sensors	9	Electromechanical Controls – Test Procedure	34
Dimensional Data	11	Start-Up	35
Weights	16	Electromechanical Controls - Sequence Of Operation	35
Rigging	16	Cooling without an Economizer	35
A2L Information	18	Evaporator Fan Operation (for Gas Units) - Standard Economizer	35
A2L Work Procedures	18	Evaporator Fan Operation (for Cooling Only Units) - Standard Economizer	35
Servicing	18	Economizer Set-Up - Standard Economizer	35
Leak Detection	19	Cooling with an Economizer - Standard Economizer	35
Refrigerant Removal and Evacuation	19	Heating Operation (Units with Electric Heat) - Standard Economizer	35
Refrigerant Charging	19	Heating Operation (for Gas Units) - Standard Economizer	36
Decommissioning	20	Ignition Module Low, Medium and High Heat	36
A2L Application Considerations	20	Two-Speed Indoor Fan Control	36
Ignition Sources in Ductwork	20	Cooling Operation	36
Ignition Sources in Unit	20	Low Pressure Cutout	36
Minimum Room Area Limits (Refrigerant charge greater than 3.91 lb per circuit)	21	High Pressure Cutout and Temperature Discharge Limit	37
Leak Detection System(Refrigerant charge greater than 3.91 lb per circuit)	22	Heating Operation	37
Installation	24	Emergency Stop	37
Unit Foundation	24	Compressor Start-Up	37
Ductwork	24	Heating Start-Up	38
General Unit Requirements	24	Final System Setup	38
Main Electrical Power Requirements	25	Refrigerant Charge and Room Area Limitations	38
External Vent Hood Installation	25	Important Service Precautions	41
Condensate Drain Configuration	25	Maintenance	44
Filter Installation	25	Fan Belt Adjustment-Belt Drive Units	44
Field Installed Power Wiring	26		
Main Unit Power	26		
Standard Wiring	26		
Control Power Transformer	26		
Controls using 24 Vac	26		
Gas Heat Data	28		
Voltage Imbalance	29		

Table of Contents

Monthly Maintenance	46	Failures	51
Filters	46	To Clear an Alarm	51
Condensate Overflow Switch	46	Resetting Cooling and Heating	
Cooling Season	46	Lockouts	51
Heating Season	47	Method 1	52
Coil Cleaning	47	Method 2	52
Variable Frequency Drive (VFD)	50	Wiring Diagrams	55
Replacing the Cooling Fan	50	Warranty	56
Reforming the Capacitors	50	For Commercial Unitary Equipment Rated	
Replacing a Fuse	50	25 Tons and Under and Related	
Troubleshooting	51	Accessories	56
Standard Troubleshooting	51	Basic Warranty	56
Ignition Module	51	Exclusions and Limitations	56

Model Number Description

Digit 1 — Unit Type

E = Packaged Cooling, Electric Heat
G = Packaged Gas/Electric

Digit 2 — Efficiency

D = ASHRAE 90.1 - 2022

Digit 3 — Airflow Configuration

K = Convertible and A2L

Digit 4, 5, 6 — Nominal Gross Cooling Capacity (MBh)

090 = 7.5 Tons

102 = 8.5 Tons

120 = 10 Tons

150 = 12.5 Tons

Digit 7 — Major Design Sequence

A = Rev A

Digit 8 — Voltage Selection

3 = 208/230/60/3

4 = 460/60/3

Digit 9 — Unit Controls

E = Electromechanical

Digit 10 — Heating Capacity

0 = Cooling Only (field installed electric heat)

H = Gas Heat - High

L = Gas Heat - Low

M = Gas Heat - Medium

Digit 11— Minor Design Sequence

A = Rev A

B = Rev B

Digit 12, 13 — Service Sequence

00 = None

Digit 14 — Fresh Air Selection

0 = No Fresh Air Options

Note: Fresh air options are available as field installed accessories.

Digit 15 — Supply Fan/Drive Type/Motor

7 = Multi-Speed Standard Motor

9 = Multi-Speed Oversized Motor

Digit 16 — Unit

M = Medium Foundation

Digit 17 — Condenser Coil Protection

0 = Standard Coil

Digit 18 — Through The Base Provisions

0 = No Through the Base Provisions

Note: Through the base Provisions are available as field installed accessories.

Digit 19 — Disconnect Switch

0 = No Disconnect/No Circuit Breaker

Note: Non-Fused Disconnect are available as field installed accessories.

Digit 20 to 24

Not Used

General Information

⚠ WARNING

Fiberglass Wool!

Exposure to glass wool fibers without all necessary PPE equipment could result in cancer, respiratory, skin or eye irritation, which could result in death or serious injury. Disturbing the insulation in this product during installation, maintenance or repair will expose you to airborne particles of glass wool fibers and ceramic fibers known to the state of California to cause cancer through inhalation.

You **MUST** wear all necessary Personal Protective Equipment (PPE) including gloves, eye protection, a NIOSH approved dust/mist respirator, long sleeves and pants when working with products containing fiberglass wool.

Precautionary Measures:

- Avoid breathing fiberglass dust.
- Use a NIOSH approved dust/mist respirator.
- Avoid contact with the skin or eyes. Wear long-sleeved, loose-fitting clothing, gloves, and eye protection.
- Wash clothes separately from other clothing; rinse washer thoroughly.
- Operations such as sawing, blowing, tear-out, and spraying may generate fiber concentrations requiring additional respiratory protection. Use the appropriate NIOSH approved respirator.

First Aid Measures:

- **Eye Contact** - Flush eyes with water to remove dust. If symptoms persist, seek medical attention.
- **Skin Contact** - Wash affected areas gently with soap and warm water after handling.

Overview of Manual

Note: One copy of this document ships inside the control panel of each unit and is customer property. It must be retained by the unit's maintenance personnel.

This booklet describes proper installation, operation, and maintenance procedures for air cooled systems. By carefully reviewing the information within this manual and following the instructions, the risk of improper operation and/or component damage will be minimized.

It is important that periodic maintenance be performed to help assure trouble free operation. A maintenance schedule is provided at the end of this manual.

Unit Inspection

To protect against loss due to damage incurred in transit, perform inspection immediately upon receipt of the unit. Check carefully for shipping damage.

Exterior Inspection

If the job site inspection reveals damage or material shortages, file a claim with the carrier immediately. Specify the type and extent of the damage on the bill of lading before signing. Notify the appropriate sales representative.

Important: Do not proceed with installation of a damaged unit without sales representative approval.

- Inspect the complete exterior for signs of shipping damages to unit or packing material.
- Verify that the nameplate data matches the sales order and bill of lading.
- Verify that the unit is properly equipped and there are no material shortages.
- Verify the power supply complies with the unit nameplate specifications.

Inspection for Concealed Damage

Inspect the components for concealed damage as soon as possible after delivery and before it is stored.

If concealed damage is discovered:

- Notify the carrier's terminal of the damage immediately by phone and by mail.
- Concealed damage must be reported within 15 days.
- Request an immediate, joint inspection of the damage with the carrier and consignee.
- Stop unpacking the unit.
- Do not remove damaged material from receiving location.
- Take photos of the damage, if possible.
- The owner must provide reasonable evidence that the damage did not occur after delivery.

Unit Storage

Take precautions to prevent condensate from forming inside the unit's electrical compartments and motors if:

- The unit is stored before it is installed; or,
- The unit is set on the roof curb, and temporary heat is provided in the building. Isolate all side panel service entrances and base pan openings (e.g., conduit holes, S/A and R/ A openings, and flue openings) from the ambient air until the unit is ready for start-up.

Note: Do not use the unit heater for temporary heat without first completing the start-up.

The manufacturer will not assume any responsibility for equipment damage resulting from condensate accumulation on the unit electrical and/or mechanical components.

⚠ WARNING

Electrical Shock Hazard!

Failure to follow instructions below could result in death or serious injury. Always turn off all power to the unit before installing or servicing the unit. There may be more than one disconnect switch. Turn off accessory heater power if applicable. Lock out and tag switch with a suitable warning label.

Unit Description

Before shipment, each unit is leak tested, dehydrated, charged with refrigerant and compressor oil, and run tested for proper control operation.

Direct-drive, vertical discharge condenser fans are provided with built-in thermal overload protection.

System Input Devices and Functions

The unit must have a thermostat input in order to operate.

The descriptions of the following basic input devices used within the unit are to acquaint the operator with their function as they interface with the various features. Refer to the unit's electrical schematic for the specific device connections. The following controls are available from the factory for field installation.

Drain Pan Condensate Overflow Switch (Optional)

This input incorporates the Condensate Overflow Switch (COF) mounted on the drain pan. When the condensate level reaches the trip point, the COF relay energizes and opens the 24 Vac control circuit, disabling the unit. A delay timer prevents the unit from starting for 7 minutes.

Discharge Line Thermostat Control

The high pressure controls and the discharge line thermostat signals are wired in series and connected to the safety input of the LSD. The compressor contactor coil is connected to the 'CC' terminal of the LSD. If the high pressure control switch or the discharge line thermostat is open, the 24 Vac signal to the SI input of the LSD is interrupted and the compressor contactor coil supply is disabled by the LSD. It has an automatic lockout.

The high pressure controls and discharge line thermostats are wired in the system protection detection port. If the high pressure control switch or the discharge line thermostat is open, the main control board will turn off the compressor of the corresponding system. There is no automatic lockout.

Evaporator Frost Control

This input incorporates the Evaporator Frost Control mounted in the indoor coil and can be activated by closing a field supplied contact installed in parallel with the Frost Control.

If this circuit is open before the compressor is started, the compressor will not be allowed to operate. Anytime this circuit is opened for 5 continuous seconds during compressor operation, the compressor for that circuit is immediately turned "Off". The compressor will not be allowed to restart for a minimum of 3 minutes should the Frost Control close.

Sensors

High Temperature Sensor (BAYFRST003*)

This sensor connects to the Emergency Stop Input on the LTB and provides high limit "shutdown" of the unit. The sensor is used to detect high temperatures due to fire in the air conditioning or ventilation ducts. The sensor is designed to mount directly to the sheet metal duct. Each kit contains two sensors. The return air duct sensor (X1310004001) is set to open at 135°F.

The supply air duct sensor (X1310004002) is set to open at 240°F. The control can be reset after the temperature has been lowered approximately 25°F below the cutout setpoint.

Thermostat (TCONT802AS32DA)

This thermostat is a multi-stage 3 heat/2 cool, autochangeover digital display thermostat. It is a programmable thermostat, and a 7-day programmable stat with night setback shall be available. In addition, it is wall mounted.

Thermostat (TCONT402AN32DA)

This thermostat is a multi-stage 3 heat/2 cool, auto changeover digital display thermostat. It is a nonprogrammable, wall-mounted thermostat, and it can be used for economizer operation.

Variable Frequency Drive (VFD)

Variable Frequency Drive (VFD) can automatically adjust the indoor fan motor speed in sequence with the unit's ventilation, cooling and heating operation. Per ASHRAE 90.1-2016 and IECC*-2015 standards, during the first stage of cooling operation the VFD will adjust the fan motor to provide 100%/70%/65% of the design airflow rate for the unit, according to the outdoor ambient temperature. When the call for the second stage of cooling is required, the VFD will allow the design airflow rate for the unit established (100%). During the heating mode, the VFD will allow total design airflow rate (100%) operation. During ventilation mode, the VFD will allow total design airflow rate (100%) operation.

Refrigerant Sensors

The units are equipped with two factory-wired R-454B leak detections for safe operation during a leak. Any

General Information

modifications to this system will result in potentially

hazardous conditions and improper equipment operation,
and void all system warranties and liabilities.

Dimensional Data

Below figure illustrates the minimum operating and service clearances for either a single or multiple unit installation. These clearances are the minimum distances necessary to assure adequate serviceability, cataloged unit capacity, and peak operating efficiency.

Providing less than the recommended clearances may result in condenser coil starvation, "short-circuiting" of exhaust and economizer airflows, or recirculation of hot condenser air.

⚠ WARNING

Airflow Obstruction!

Failure to follow instructions below could result in death or serious injury or property damage.

Use the unit in well-ventilated spaces and ensure that there are no obstructions that could impede the airflow into and out of the unit. Do not use this unit in:

- **Locations with mineral oil, saline atmospheres (seaside locations), sulfurous atmospheres (natural hot springs), area with high voltage electricity (industrial locations).**
- **On vehicles or vessels, such as trucks or ferry boats.**
- **Areas exposed to oily or humid air, such as kitchens.**
- **In proximity to sources of electromagnetic radiation, such as high-frequency transmitters or other high strength radiation devices.**

Dimensional Data

Figure 1. Typical installation clearance for single and multiple unit applications (in inches)

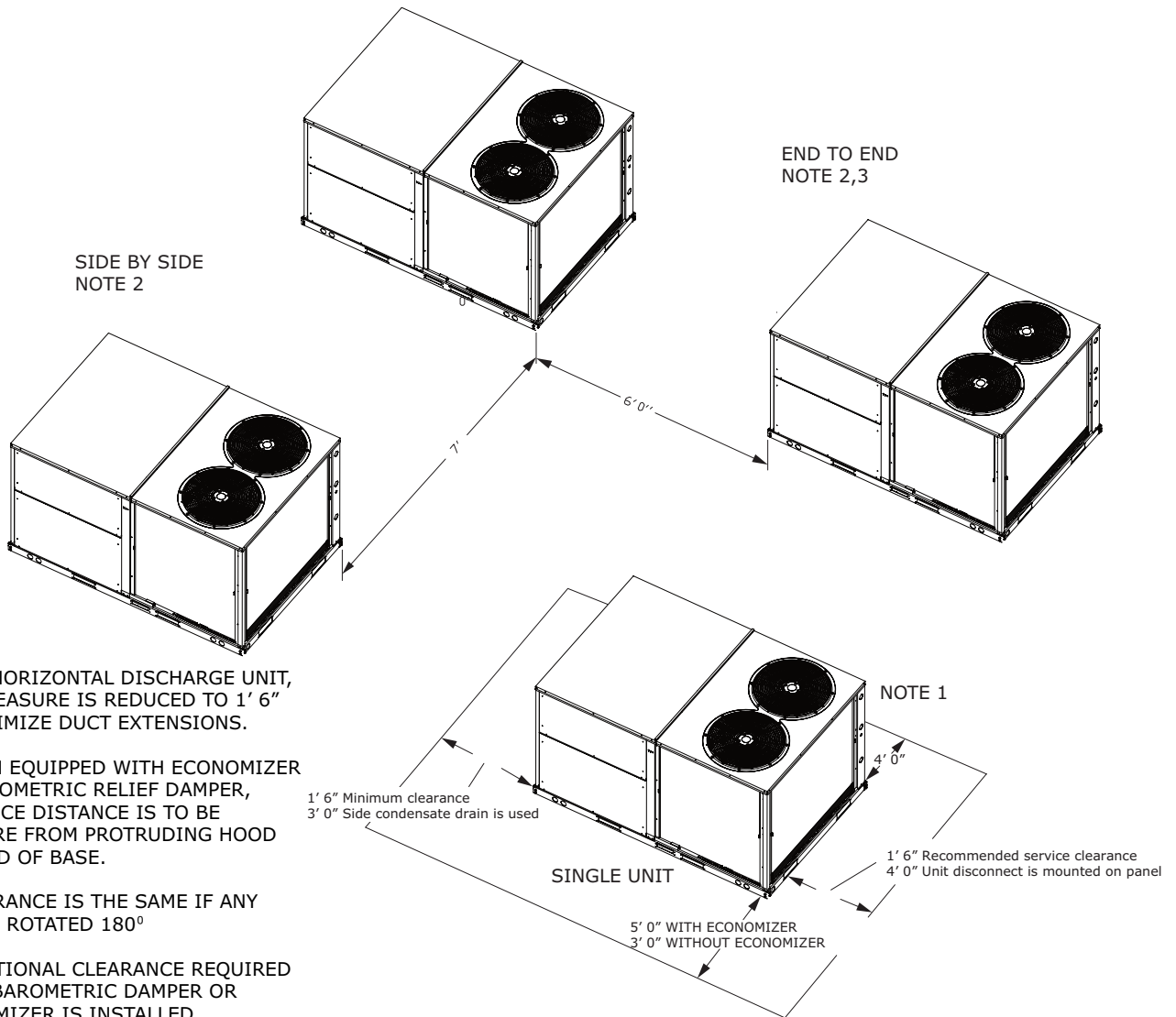

Figure 2. Gas/electric units — overview

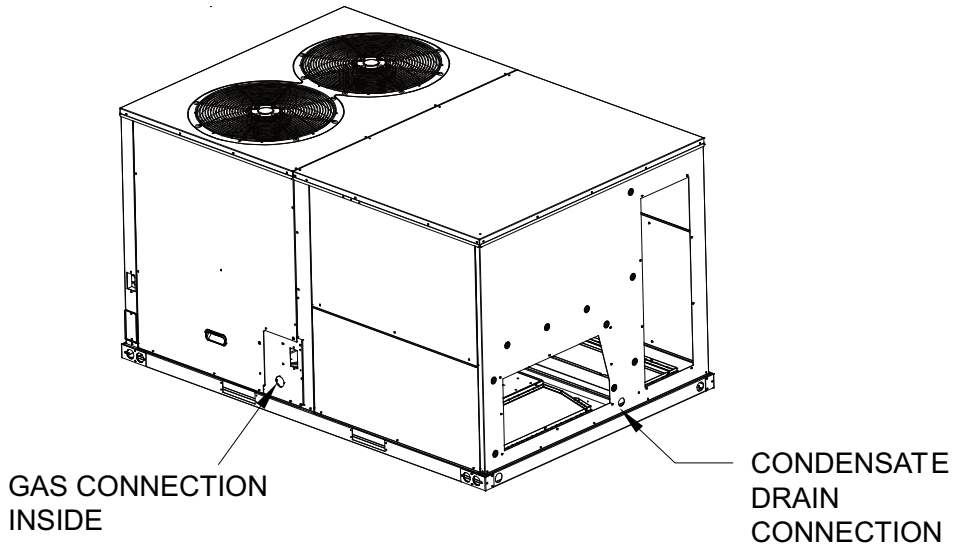
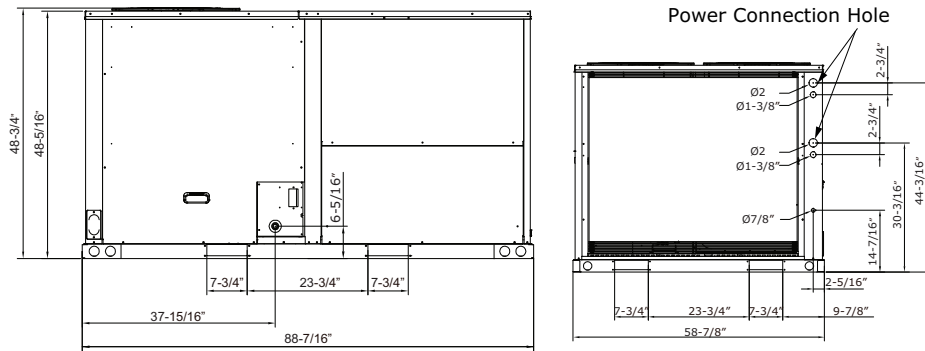
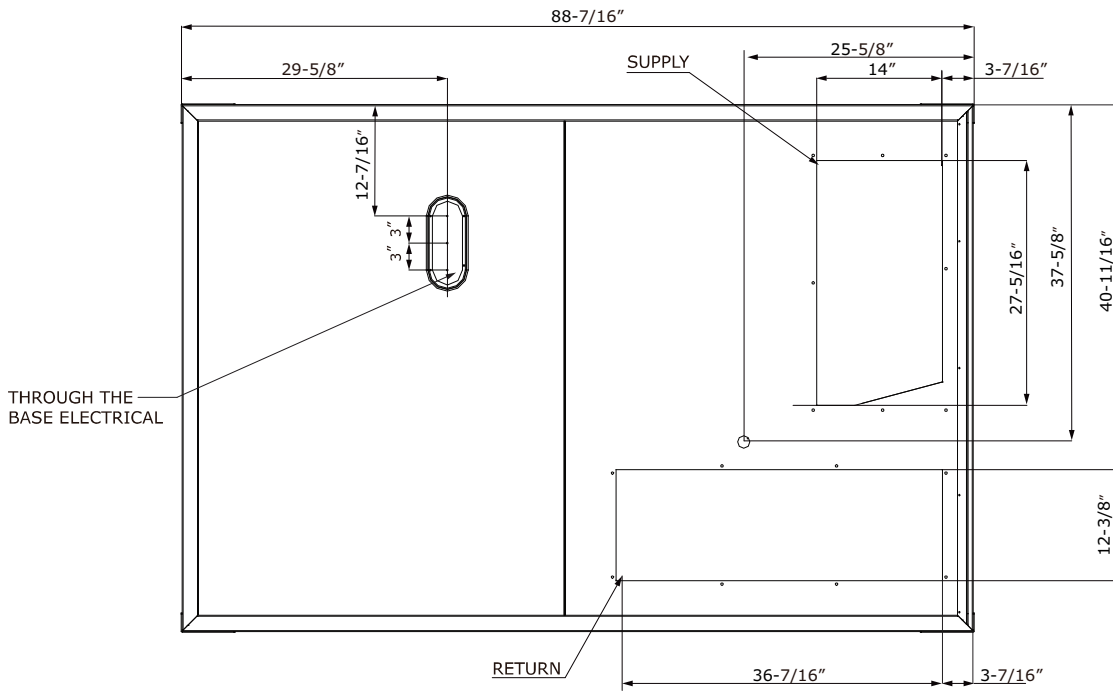

Figure 3. Gas/electric units — overview



Dimensional Data

Figure 4. Gas/electric units — bottom view (in inches)



NOTES:

1. THROUGH THE BASE GAS AND ELECTRICAL IS NOT STANDARD ON ALL UNITS.
2. VERIFY WEIGHT, CONNECTION, AND ALL DIMENSION WITH INSTALLER DOCUMENTS BEFORE INSTALLATION.

Figure 5. Foundation units — back view (horizontal configuration) (in inches)

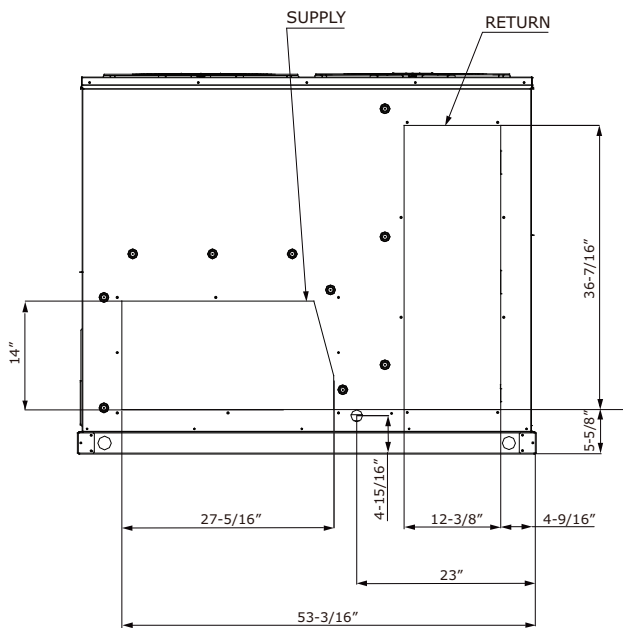

Figure 6. Roof curb (in inches)

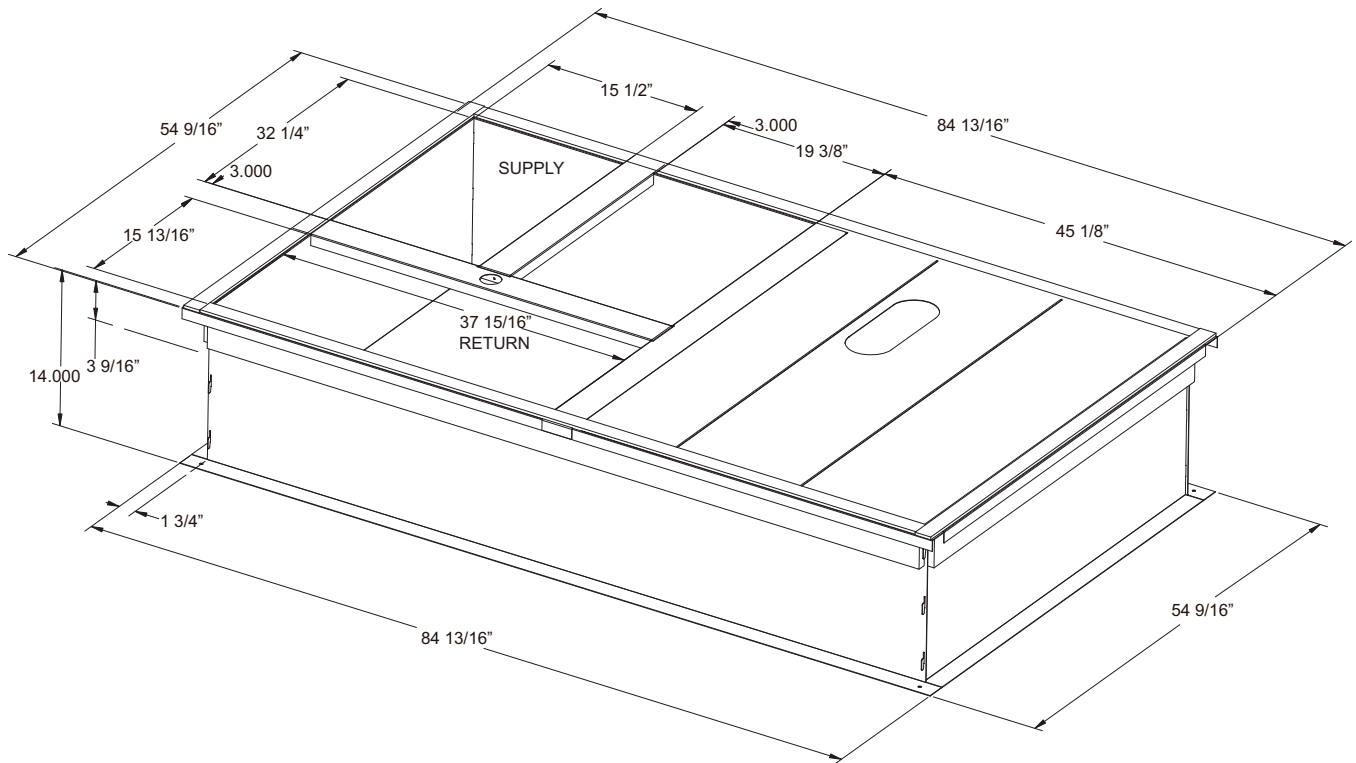
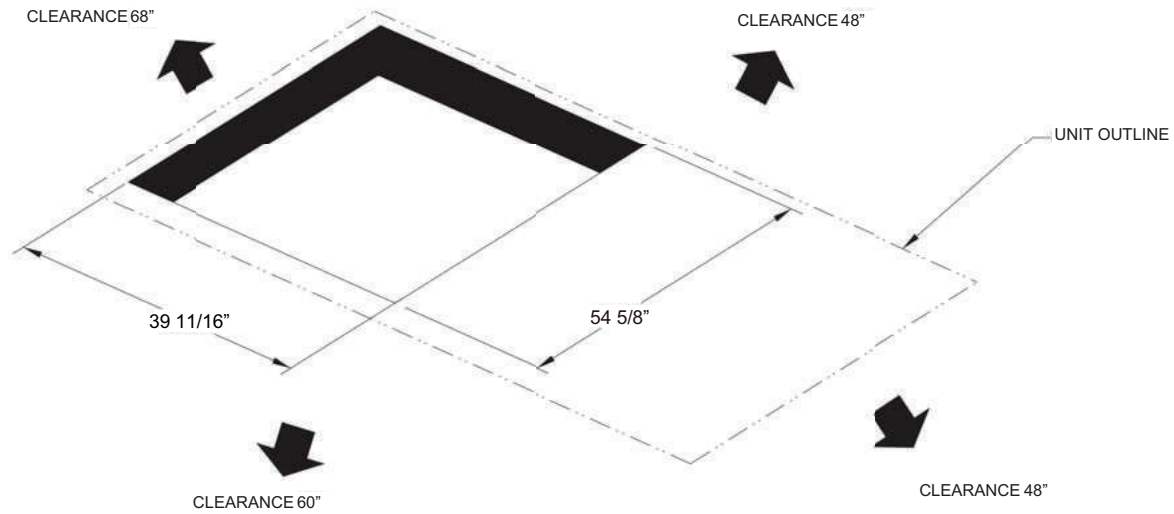

Figure 7. Downflow unit clearance (in inches)



Weights

Table 1. Maximum unit and corner weights (lb) and center of gravity dimensions (in.)

Tons	Unit Model No.	Weights (lb) ^(a) , ^(b)		Corner Weights ^(c)				Center of Gravity (in.)	
		Shipping	Net	A	B	C	D	Length	Width
7.5	GDK090A	1087	1025	247	246	265	267	44	33
8.5	GDK102A	1124	1063	254	246	275	287	43	35
10	GDK120A	1157	1096	289	242	257	317	38	33
12.5	GDK150A	1237	1175	306	257	278	344	38	34
7.5	EDK090A	979	917	221	220	237	238	44	33
8.5	EDK102A	1016	955	228	221	247	258	43	35
10	EDK120A	1047	985	260	217	231	284	38	33
12.5	EDK150A	1127	1065	277	233	252	311	38	34

^(a) Weights are approximate. Horizontal and downflow unit and corner weights may vary slightly.

^(b) Weights do not include additional factory or field installed options/accessories.

^(c) Corner weights are given for information only. 7.5 to 12.5 ton models must be supported continuously by a curb or equivalent frame support.

Figure 8. Center of gravity/corner weights

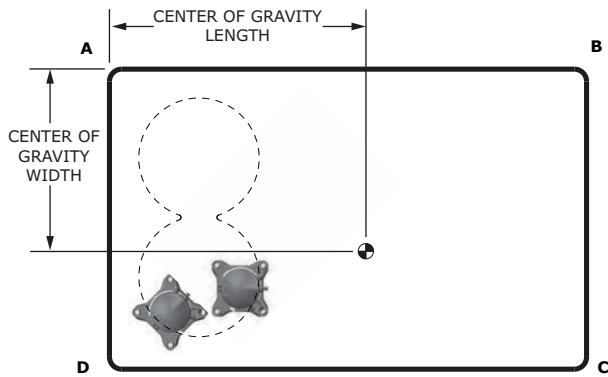

Rigging

⚠ WARNING

Heavy Object!

Failure to follow instructions below could result in unit dropping which could result in death or serious injury, and equipment or property-only damage.

Ensure that all the lifting equipment used is properly rated for the weight of the unit being lifted. Each of the cables (chains or slings), hooks, and shackles used to lift the unit must be capable of supporting the entire weight of the unit. Lifting cables (chains or slings) may not be of the same length. Adjust as necessary for even unit lift.

⚠ WARNING

Improper Unit Lift!

Failure to properly lift unit in a LEVEL position could result in unit dropping and possibly crushing operator/technician which could result in death or serious injury, and equipment or property-only damage.

Test lift unit approximately 24 inches (61 cm) to verify proper center of gravity lift point. To avoid dropping of unit, reposition lifting point if unit is not level.

Refer to [Figure 9, p. 17](#) and for typical unit operating weights rigging before proceeding.

1. Remove the shipping crate from around the unit. Do not remove the crating from the top of the unit.
2. Rig the unit as shown in [Figure 9, p. 17](#). Attach adequate strength lifting slings to all four lifting brackets in the unit base rail. Do not use cables, chains, or slings except as shown.
3. Install a lifting bar, as shown in [Figure 9, p. 17](#), to protect the unit and to facilitate a uniform lift. The minimum distance between the lifting hook and the top of the unit should be 7 feet.
4. Test-lift the unit to ensure it is properly rigged and balanced, make any necessary rigging adjustments.
5. Lift the unit and position it into place.
6. Downflow units; align the base rail of the unit with the curb rail while lowering the unit onto the curb. Make sure that the gasket on the curb is not damaged while positioning the unit.

Figure 9. Rigging and center of gravity data

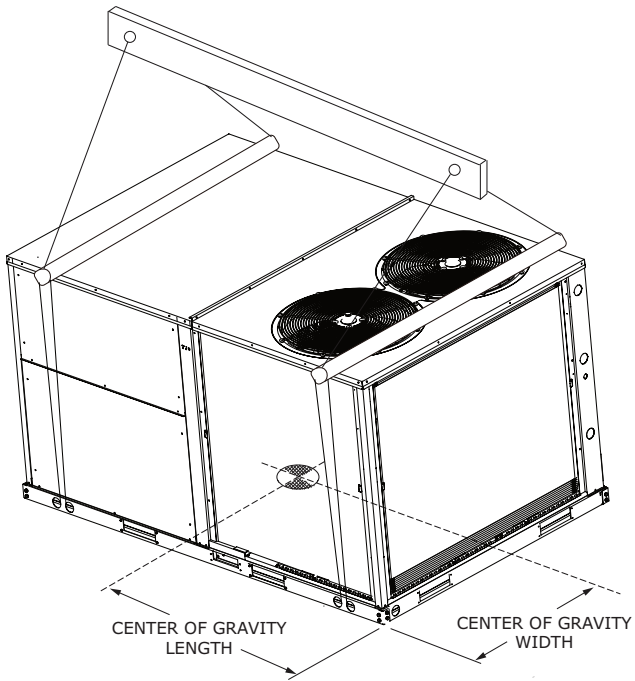

A2L Information

A2L Work Procedures

⚠ WARNING

Risk of Fire — Flammable Refrigerant!

Failure to follow instructions below could result in death or serious injury, and equipment damage.

- To be repaired only by trained service personnel.
- Do not puncture refrigerant tubing.
- Dispose of properly in accordance with federal or local regulations.

⚠ WARNING

Refrigerant under High Pressure!

Failure to follow instructions below could result in an explosion which could result in death or serious injury or equipment damage.

System contains refrigerant under high pressure. Recover refrigerant to relieve pressure before opening the system. See unit nameplate for refrigerant type. Do not use non-approved refrigerants, refrigerant substitutes, or refrigerant additives.

⚠ WARNING

Hazardous Voltage!

Failure to disconnect power before servicing could result in death or serious injury.

Disconnect all electric power, including remote disconnects before servicing. Follow proper lockout/tagout procedures to ensure the power can not be inadvertently energized. Verify that no power is present with a voltmeter.

The units described in this manual use R-454B refrigerant. Use ONLY R-454B rated service equipment or components with these units. For specific handling concerns with R-454B, contact your local Trane representative.

Installation, repair, removal, or disposal should be performed by trained service personnel.

At all times, Trane's maintenance and service guidelines shall be followed. If in doubt, contact Trane technical support for assistance.

Service

Prior to initiating work on equipment, check the area with an appropriate refrigerant detector. Ensure the service personnel are properly trained regarding work in potentially toxic or flammable atmospheres. Ensure that the leak detection equipment being used is suitable for use with all applicable refrigerants, i.e. non-sparking, adequately

sealed, or intrinsically safe. Be aware that the refrigerant does not contain an odor.

If any hot work is to be conducted on the refrigerating equipment or any associated parts, appropriate fire extinguishing equipment shall be available on hand. A dry powder or CO₂ fire extinguisher should be located adjacent to the charging area.

At all times, Trane's maintenance and service guidelines shall be followed. If in doubt, contact Trane technical support for assistance.

All maintenance staff and others working in the local area shall be instructed on the nature of the work being carried out. Work in confined spaces shall be avoided.

Ignition Source Mitigation

Do not use any sources of ignition when working on the refrigeration system.

Keep all ignition sources, including cigarette smoking, away from the site of installation, repair, removal or disposal, during which refrigerant can potentially be released to the surrounding space.

Survey the area around the equipment before initiating work to ensure no flammable hazards or ignition risks are present.

"No Smoking" signs shall be displayed.

Do not use devices that can be a source of ignition to accelerate defrosting of components. Use only defrost and cleaning procedures recommended by Trane. Do not pierce or burn.

Ventilation

Ensure that the area is in the open or that it is adequately ventilated before breaking into the system or conducting any hot work. A degree of ventilation shall continue during the period that the work is carried out. The ventilation should safely disperse any released refrigerant and preferably expel it externally into the atmosphere. If present, check that the ventilation system, including outlets, are operating adequately and are not obstructed.

Refrigerating Equipment

Refrigerant piping or components should not be installed in locations where substances which may corrode them are present.

Check that equipment hazard markings are visible and legible. Replace them if they are not.

For equipment using secondary fluids, like water or glycol, check that refrigerant is not present in the secondary fluid loop before conducting any hot work.

Electrical Devices

Do not apply power to the circuit if a fault exists which compromises safety. If the fault cannot be corrected immediately, but it is necessary to continue operation, an

adequate temporary solution shall be used. This shall be reported to the owner of the equipment, so all parties are advised.

Initial safety checks shall include:

- Cabling is not subject to wear, corrosion, excessive pressure, vibration, sharp edges, or any other adverse environmental effects. Account for the effects of aging or continual vibration from sources such as compressors or fans.
- Capacitors are discharged. This shall be done in a safe manner to avoid possibility of sparking.
- No live electrical components and wiring are exposed while charging, recovering, or purging the system.
- Verify continuity of earth bonding.
- Replace electrical components with Trane replacement parts, or those meeting the same ratings and qualified for flame arrest protection, UL LZGH2 category.

Leak Detection

Never use an open flame to detect leaks. A halide torch should not be used. Use only approved leak detection methods per this instruction manual.

The following leak detection methods are deemed acceptable for all refrigerant systems.

Electronic leak detectors may be used to detect refrigerant leaks but, in the case of flammable refrigerants, the sensitivity may not be adequate, or may need re-calibration. (Detection equipment shall be calibrated in a refrigerant-free area.) Ensure that the detector is not a potential source of ignition and is suitable for the refrigerant used. Leak detection equipment shall be set at a percentage of the LFL gas (25% maximum) is confirmed.

Leak detection fluids are also suitable for use with most refrigerants but the use of detergents containing chlorine shall be avoided as the chlorine may react with the refrigerant and corrode the copper pipe-work.

Examples of leak detection fluids are:

- Bubble method
- Fluorescent method agents

If a leak is suspected, all naked flames shall be removed/ extinguished.

If a refrigerant leak is found which requires brazing, all refrigerant shall be recovered from the system, or isolated (by means of shut off valves) in a part of the system remote from the leak.

Refrigerant Removal and Evacuation

When breaking into the refrigerant circuit to make repairs – or for any other purpose – conventional procedures shall be used. However, for flammable refrigerants it is important that best practice be followed, since flammability is a consideration.

The following procedure shall be adhered to:

1. Safely remove refrigerant following local and national regulations.
2. Evacuate.
3. Purge the circuit with inert gas.
4. Evacuate (optional for A2L).
5. Continuously flush or purge with inert gas when using flame to open circuit.
6. Open the circuit.

Prior to refrigerant removal, open all appropriate valves, including solenoid and electronic expansion valves (EXVs). Use control settings, where available. When not available, manually open all electronically controlled valves using acceptable service procedures.

The recovery equipment shall be in good working order with instructions available. Equipment shall be suitable for the recovery of the flammable refrigerant. For specific handling concerns, contact the manufacturer. Ensure all hose connections are checked for tightness to avoid refrigerant leaks.

The refrigerant shall be recovered into the correct recovery cylinders if venting is not allowed by local and national codes. Do not mix refrigerants in recovery unit and especially not in cylinders.

Refrigerant recovery unit should be purged with an inert gas after each use or before using with a different refrigerant Class – for example, A2L to A1.

If compressors or compressor oils are to be removed, ensure that they have been evacuated to an acceptable level to make certain that flammable refrigerant does not remain within the lubricant. The compressor body shall not be heated by an open flame or other ignition sources to accelerate this process. When oil is drained from a system, it shall be carried out safely.

The system shall be purged with oxygen-free nitrogen to render the appliance safe for flammable refrigerants. This process might need to be repeated several times. Compressed air or oxygen shall not be used for purging refrigerant systems.

The system shall be vented down to atmospheric pressure to enable work to take place.

The outlet for the vacuum pump shall not be close to any potential ignition sources, and ventilation shall be available.

Refrigerant Charging

In addition to conventional charging procedures, the following requirements shall be followed.

- Ensure that contamination of different refrigerants does not occur when using charging equipment.
- Hoses or lines shall be as short as possible to minimize the amount of refrigerant contained in them.
- Cylinders shall be kept in an appropriate position according to the instructions.

A2L Information

- Ensure that the refrigerating system is earthed prior to charging the system with refrigerant.
- Label the system when charging is complete (if not already).
- Extreme care shall be taken not to overfill the refrigerating system.

Prior to recharging the system, it shall be pressure-tested with the appropriate purging gas. The system shall be leak-tested on completion of charging but prior to commissioning. A follow up leak test shall be carried out prior to leaving the site.

Prior to refrigerant charging, open all appropriate valves, including solenoid and electronic expansion valves (EXVs). Use control settings, where available. When not available, manually open all electronically controlled valves using acceptable service procedures.

Decommissioning

Before carrying out the decommissioning procedure, it is essential that the trained service personnel is completely familiar with the equipment and all its details. It is recommended good practice that all refrigerants are recovered safely. Prior to the task being carried out, an oil and refrigerant sample shall be taken in case analysis is required prior to re-use of recovered refrigerant. It is essential that electrical power is available before the task is commenced.

1. Become familiar with the equipment and its operation.
2. Isolate system electrically.
3. Before attempting the procedure, ensure that:
 - a. Mechanical handling equipment is available, if required, for handling refrigerant cylinders.
 - b. All personal protective equipment is available and being used correctly.
 - c. The recovery process is supervised at all times by a competent person.
 - d. Recovery equipment and cylinders conform to the appropriate standards.
4. Pump down refrigerant system, if possible.
5. If a vacuum is not possible, make a manifold so that refrigerant can be removed from various parts of the system.
6. Make sure that cylinder is situated on the scales before recovery takes place.
7. Start the recovery machine and operate in accordance with instructions.
8. Do not overfill cylinders (no more than 80% volume liquid charge).
9. Do not exceed the maximum working pressure of the cylinder, even temporarily.
10. When the cylinders have been filled correctly and the process completed, make sure that the cylinders and

the equipment are removed from site promptly and all isolation valves on the equipment are closed off.

11. Recovered refrigerant shall not be charged into another refrigerating system unless it has been cleaned and checked.
12. When equipment has been decommissioned, attach a signed label which includes the date of decommissioning.

A2L Application Considerations

This product is listed to UL standard 60335-2-40, Household and Similar Electrical Appliances – Safety – Part 2-40: Particular Requirements for Electrical Heat Pumps, Air-Conditioners and Dehumidifiers, which defines safe design and use strategies for equipment using A2L refrigerants. This standard limits the refrigerant concentration in a space in the event of a refrigerant leak. To meet the requirements, the UL standard defines minimum room area, refrigerant charge limit, minimum circulation airflow and/or ventilation airflow requirements, and limits the use of ignition sources in spaces. The standard may require a unit refrigerant leak detection system.

For equipment with R-454B and charge amounts less than or equal to 3.91 lbs per circuit, this UL standard does not prescribe a room area limit and does not require a refrigerant leak detection system or any circulation airflow or ventilation airflow mitigation strategies. However, ignition sources in ductwork must be evaluated.

Depending on the application, a specific requirement of ANSI/ASHRAE Standard 15, Safety Standard for Refrigeration Systems, could be more stringent than UL 60335-2-40 requirements. See *Refrigeration Systems and Machinery Rooms Application Considerations for Compliance with ASHRAE® Standard 15-2022 Application Engineering Manual* (APP-APM001*-EN) for more information.

Ignition Sources in Ductwork

Do not install open flames in the ductwork. Hot surfaces exceeding 700°C (1290°F) should not be installed in the ductwork unless the average airflow velocity is not less than 1.0 m/s (200 ft/min) across the heater and proof of airflow is verified before system is energized.

Electric heaters can exceed the surface temperature limit if airflow distribution is poor, or insufficient airflow is provided over the heater.

Surface temperatures of most gas heaters do not exceed the surface temperature limits due to ANSI construction requirements.

Ignition Sources in Unit

This UL-listed unit does not contain any ignition sources. All potential ignition sources, (including factory or field installed accessory electric heaters, gas heaters, relays, and contactors) were evaluated during product UL listing.

Minimum Room Area Limits (Refrigerant charge greater than 3.91 lb per circuit)

Equipment with R-454B charge amounts greater than 3.91 lb per circuit may require additional circulation or ventilation airflow mitigation strategies. In this case, two minimum room area (A_{min}) thresholds:

- The first threshold defines when equipment serving a single room is required to provide circulation airflow, either continuous or activated by a leak detection system. A ducted system requires circulation airflow

unless the smallest room it serves is larger than the adjusted A_{min} threshold. This product contains a leak detection system if a circuit charge is greater than 3.91 lbs. As a result, no further leak detection system evaluation is required.

- The second threshold defines when additional ventilation airflow is required. If the room area, A or TA, is below the adjusted A_{min} or TA_{min} threshold, additional ventilation is required to remove refrigerant in the event of a leak. Refer to UL 60335-2-40 Clause GG.8 and ANSIASHRAE Standard 15 Section 7 for natural and mechanical ventilation requirements.

Table 2. Minimum room area

Charge		Minimum Room Area	
lb-oz	kg	ft ²	m ²
4-6	2.0	66.1	6.1
4-13	2.2	72.7	6.8
5-4	2.4	79.3	7.4
5-11	2.6	86.0	8
6-2	2.8	92.6	8.6
6-9	3.0	99.2	9.2
7-0	3.2	105.8	9.8
7-7	3.4	112.4	10.4
7-15	3.6	119.0	11.1
8-6	3.8	125.6	11.7
8-13	4.0	132.2	12.3
9-4	4.2	138.8	12.9
9-11	4.4	145.5	13.5
10-2	4.6	152.1	14.1
10-9	4.8	158.7	14.7
11-0	5.0	165.3	15.4
11-7	5.2	171.9	16.0
11-14	5.4	178.5	16.6
12-5	5.6	185.1	17.2
12-12	5.8	191.7	17.8
13-3	6.0	198.4	18.4
13-10	6.2	205.0	19.0
14-1	6.4	211.6	19.7
14-8	6.6	218.2	20.3
14-15	6.8	224.8	20.9
15-6	7.0	231.4	21.5
15-14	7.2	238.0	22.1
16-5	7.4	244.6	22.7
16-12	7.6	251.2	23.3
17-3	7.8	257.9	24.0

Minimum Room Area (A_{min}) Adjustments

Use equation below to adjust the minimum room area, as applicable, based on the unit's installation height, altitude, and occupancy level it serves.

$$A_{min.adj} = \text{Nameplate } A_{min} \times \text{Altitude Adj} \times \text{Height Adj} \times F_{Occ}$$

Table 3. Altitude adjustment factor

Altitude (ft)	Sea Level to 2000	2001 to 4000	4001 to 6000	6001 to 8000	8001 to 10000	10001 to 12000	12001 to 14000	14001 to 15000	Over 15000
A_{min} Adjustment	1	1.05	1.11	1.17	1.24	1.32	1.41	1.51	1.57

In addition, A_{min} can be adjusted if the unit is installed in a room at a height that is higher than the minimum height shown on the unit. To adjust A_{min} , multiply by the ratio of the unit minimum release height (in meters) / actual release height (in meters). Use 0.6 m in the ratio for unit minimum installation heights less than or equal to 0.6 m.

For institutional occupancies, ASHRAE Standard 15 applies an additional adjustment factor F_{Occ} to the amount of a charge allowed in a space. To calculate the adjusted A_{min} for institutional occupancies, multiply the A_{min} on the nameplate by two.

EXAMPLE 1: 20 Ton Packaged Rooftop Multi-Zone VAV System Serving an Institutional Occupancy Space

The packaged unit serves 7600 ft² of a nursing home located at an altitude of 4000 ft. The unit has two equally charged 10 ton refrigeration circuits. Each circuit has 12 lbs of refrigerant with a minimum room area requirement of 180 ft² with a 2.2 m release height.

$$TA_{min.adj} = 180 \text{ ft}^2 \times 1.05 \times 2 = 378 \text{ ft}^2$$

No additional ventilation is required.

EXAMPLE 2: 10 Ton Split System Serving a Single Commercial Occupancy Space

The split system serves a 1500 ft² manufacturing space at 5000 ft altitude. The final installed charge of the single circuit 10 ton unit is 20 lb. The unit has an open return with a release height of 1 m and ducted supply air. The unit A_{min} is 660 ft².

$$A_{min.adj} = 660 \text{ ft}^2 \times 1.11 = 733 \text{ ft}^2$$

No additional ventilation is required.

Determining Room Area (A or TA)

The room area (A) is the room area enclosed by the projection to the floor of the walls, partitions, and doors of the space that the equipment serves. For ducted systems, total room area (TA) of all rooms connected by ducts, may be used instead of A.

Rooms connected by drop ceilings only are not considered a single room.

Multiply the altitude adjustment factor in the table below by A_{min} listed on the unit nameplate or in the Installation, Operation, and Maintenance (IOM) manual.

Rooms on the same floor of the building, and connected by an open passageway, can be considered part of the same room if the passageway is a permanent opening, extends to the floor and is intended for people to walk through.

Adjacent rooms on the same floor of the building and connected by permanent openings in the walls and/or doors between rooms (including gaps between the wall and the floor), can be considered part of the same room if the openings meet the following criteria.

- The opening is permanent and cannot be closed.
- Openings extending to the floor, such as door gaps, need to be at least 20 mm above the floor covering surface.
- Natural ventilations opening areas must meet the requirements of ANSIASHRAE Standard 15-2022, Section 7.2.3.2.

Rooms that are connected by a mechanical ventilation system can be considered a single room area if the mechanical ventilation system meets the requirements of ANSIASHRAE Standard 15-2022, Section 7.6.4.

Leak Detection System (Refrigerant charge greater than 3.91 lb per circuit)

The leak detection system consists of one or more refrigerant detection sensors. When the system detects a leak, the following mitigation actions will be initiated until refrigerant has not been detected for at least 5 minutes:

- Energize the supply fan(s) to deliver a required minimum amount of circulation airflow.
- Disable compressor operation.
- Provide an output signal to fully open all zoning dampers, such as VAV boxes.
- Provide an output to energize additional mechanical ventilation (if needed).
- Units without airflow proving will disable electric heat sources.

Building fire and smoke systems may override this function.

If the refrigerant sensor has a fault, is at the end of its life, or is disconnected, the unit will initiate the mitigation

actions. Mitigation actions may be verified by disconnecting the sensor.

The refrigerant sensors do not need service. Use only manufacturer-approved sensors when replacement is required.

Installation

Unit Foundation

⚠ WARNING

Risk of Roof Collapsing!

Failure to ensure proper structural roof support could cause the roof to collapse, which could result in death or serious injury and property damage.

Confirm with a structural engineer that the roof structure is strong enough to support the combined weight of the roof curb, the unit, and any accessories.

NOTICE

Water Damage!

Failure to follow instructions below could result in equipment and property damage.

Non-factory penetrations through the base of this unit are not allowed. Any penetration in the base of the unit may affect the water tight integrity of the unit and lead to water leaks into the conditioned space.

Notes:

- For units with optional Condensate Overflow Switch (COF) accessory kit, the switch will not work properly if unit is not level or slightly sloped toward switch.
- To assure proper condensate flow during operation the unit and the curb must be level.

If the unit is installed at ground level, elevate it above the snow line. Provide concrete footings at each support location with a "full perimeter" support structure or a slab foundation for support. Refer to for the unit's operating and point loading weights when constructing a footing foundation.

If anchoring is required, anchor the unit to the slab using hold down bolts or isolators. Isolators should be installed to minimize the transmission of vibrations into the building.

For rooftop applications, if anchoring is required, anchor the unit to the roof with hold-down bolts or isolators.

Check with a roofing contractor for proper waterproofing procedures.

Important: Use only with type of gas approved for this furnace. Refer to the furnace rating plate. Install this furnace only in a location and position and provide adequate combustion and ventilation air to the furnace space as mentioned in the installation instructions below.

Ductwork

Elbows with turning vanes or splitters are recommended to minimize air noise due to turbulence and to reduce static pressure.

When attaching the ductwork to the unit, provide a watertight flexible connector at the unit to prevent operating sounds from transmitting through the ductwork.

All outdoor ductwork between the unit and the structure should be weather proofed after installation is completed.

Note: For sound consideration, cut only the holes in the roof deck for the ductwork penetrations. Do not cut out the entire roof deck within the curb perimeter.

If a Curb Accessory Kit is not used:

1. The ductwork can be attached directly to the factory-provided flanges around the unit's supply and return air openings. Be sure to use flexible duct connections at the unit.
2. For "built-up" curbs supplied by others, gaskets must be installed around the curb perimeter flange and the supply and return air opening flanges.

General Unit Requirements

The checklist listed below is a summary of the steps required to successfully install a commercial unit. This checklist is intended to acquaint the installing personnel with what is required in the installation process. It does not replace the detailed instructions called out in the applicable sections of this manual.

- Check the unit for shipping damage and material shortage; file a freight claim and notify appropriate sales representative.
- Verify correct model, options and voltage from nameplate.
- Verify that the installation location of the unit will provide the required clearance for proper operation.
- Assemble and install the roof curb (if applicable). Refer to the latest edition of the curb installers guide that ships with each curb kit.
- Fabricate and install ductwork; secure ductwork to curb.
- Rigging the unit.
- Set the unit onto the curb; check for levelness.
- Ensure unit-to-curb seal is tight and without buckles or cracks.
- Install and connect a condensate drain line to the evaporator drain connection.

⚠ WARNING

Risk of Fire and Property Damage!

Failure to follow instructions below could cause a fire which could result in death, serious injury, and/or property damage.

Do NOT expose combustible (non-metal) material to the supply opening of a downflow unit.

Important: The first 6 inches of supply air plenum and ductwork must be constructed of sheet metal as required by NFPA 90B. The supply air plenum or duct must have a solid sheet metal bottom directly under the unit with no openings, registers, or flexible air ducts located in it. If flexible supply air ducts are used, they must be located only in the vertical walls of rectangular plenum, a minimum of 6 inches from the solid bottom. Metal plenum or duct may be connected to the combustible floor base; if not, it must be connected to the unit supply duct exposed to the supply air opening from the downflow unit.

Main Electrical Power Requirements

- Verify that the power supply complies with the unit nameplate specifications.
- Inspect all control panel components; tighten any loose connections.
- Connect properly sized and protected power supply wiring to a field-supplied/ installed disconnect switch and to the main power terminal block in the unit control panel.
- Install proper grounding wires to an earth ground.

Note: All field-installed wiring must comply with NEC and applicable local codes.

⚠ WARNING

Hazardous Voltage!

Failure to follow instructions below could result in death or serious injury.

Disconnect all power to unit before installing or servicing. More than one disconnect switch may be required to de-energize the equipment.

External Vent Hood Installation

1. Remove and discard the cover plate located on the gas heat panel.

Important:

- Make sure you read the label located on the cover plate before you discard it.
- Do not discard the fastening screws! They will be needed to install the vent hood.

Figure 10. Vent hood installation

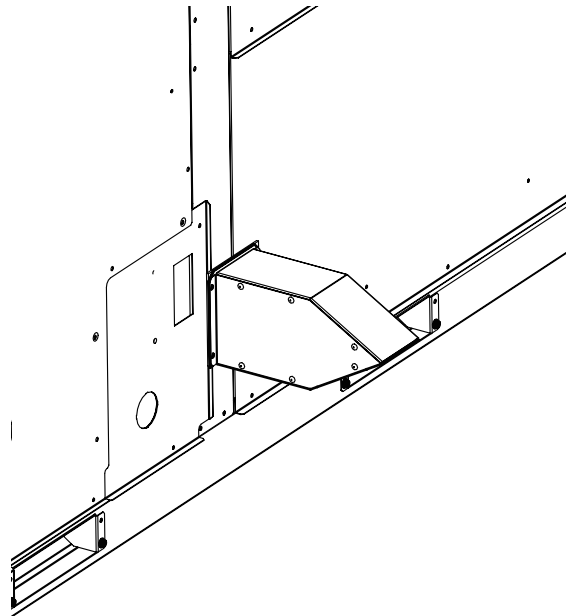

Note: Vent hood image above is for reference only. Please make the object as the standard and verify it functions to prevent rain and foreign bodies. It should not be changed without consultation.

Condensate Drain Configuration

An evaporator condensate drain connection is provided on each unit. Refer to “Dimensional Data,” p. 11 for the appropriate drain location.

Note: Use 1-inch PVC pipe to connect to the drain pan outlet provided in the unit. This is a slip fit joint (no threads). Do not use PVC glue to connect condensate drain, thread sealing compound or Teflon tape may be used.

A condensate trap must be installed at the unit due to the drain connection being on the negative pressure side of the fan.

A condensate drain line must be connected to the P-Trap. Pitch the drain lines at least 0.5-inch for every 10 feet of horizontal run to assure proper condensate flow. Do not allow the horizontal run to sag causing a possible doubletrap condition which could result in condensate backup due to air lock.

Filter Installation

Each unit ships with 2-inch filters installed. The quantity of filters is determined by unit size. Access to the filters is obtained by removing the filter access panel.

Note: Do not operate the unit without filters.

Field Installed Power Wiring

An overall dimensional layout for the standard field installed wiring entrance into the unit is illustrated in “Dimensional Data,” p. 11. To insure the unit’s supply power wiring is properly sized and installed, follow the guidelines outlined below.

Note: All field installed wiring must conform to NEC guidelines as well as state and Local codes.

Verify that the power supply available is compatible with the unit’s nameplate ratings. The available supply power must be within 10 percent of the rated voltage stamped on the nameplate. Use only copper conductors to connect the power supply to the unit.

⚠ WARNING

Electrical Shock Hazard!
 Failure to follow instructions below could result in death or serious injury.
 Always turn off all power to the unit before installing or servicing the unit. There may be more than one disconnect switch. Turn off accessory heater power if applicable. Lock out and tag switch with a suitable warning label.

Important: A field supplied disconnect switch must be installed at or near the unit in accordance with the National Electrical Code (NEC latest edition).

Main Unit Power

⚠ WARNING

Proper Field Wiring and Grounding Required!
 Failure to follow code could result in death or serious injury.
 All field wiring **MUST** be performed by qualified personnel. Improperly installed and grounded field wiring poses **FIRE** and **ELECTROCUTION** hazards. To avoid these hazards, you **MUST** follow requirements for field wiring installation and grounding as described in NEC and your local/state/national electrical codes.

Standard Wiring

The electrical service must be protected from over current and short circuit conditions in accordance with NEC requirements.

Table 4. Electromechanical thermostat 24V AC conductors with electromechanical unit

Distance from Unit to Control	Recommended Wire Size
0 - 30 feet	22 gauge
0 - 9.1 m	0.33 mm ²

Protection devices must be sized according to the electrical data on the nameplate.

- A field supplied disconnect switch must be installed at or near the unit in accordance with the National Electrical Code (NEC latest edition).
- Location of the applicable electrical service entrance is illustrated in “Dimensional Data,” p. 11. Complete the unit’s power wiring connections onto either the main terminal block inside the unit control panel or the electric heat terminal block. Refer to the customer connection diagram that shipped with the unit for specific termination points.
- Provide proper grounding for the unit in accordance with local and national codes.

Control Power Transformer

The 24-volt control power transformers are to be used only with the accessories called out in this manual.

Controls using 24 Vac

Before installing any connecting wiring, refer to “Dimensional Data,” p. 11 for the electrical access locations provided on the unit and Table 4, p. 26 for AC conductor sizing guidelines.

NOTICE

Use Copper Conductors Only!
 Failure to use copper conductors could result in equipment damage as the equipment was not designed or qualified to accept other types of conductors.

1. Use copper conductors unless otherwise specified.
2. Ensure that the AC control wiring between the controls and the unit’s termination point does not exceed three (3) ohms/conductor for the length of the run.
Note: Resistance in excess of 3 ohms per conductor could cause component failure due to insufficient AC voltage supply.
3. Be sure to check all loads and conductors for grounds, shorts, and mis-wiring.
4. Do not run the AC low voltage wiring in the same conduit with the high voltage power wiring.

Table 4. Electromechanical thermostat 24V AC conductors with electromechanical unit (continued)

Distance from Unit to Control	Recommended Wire Size
31 - 50 feet	20 gauge
9.5 - 15.2 m	0.50 mm ²
51 - 75 feet	18 gauge
15.5 - 22.9 m	0.75 mm ²
76 - 125 feet	16 gauge
23.1 - 38.1 m	1.3 mm ²
126 - 200 feet	14 gauge
38.4 - 60.9 m	2.0 mm ²

Figure 11. Conventional thermostat field wiring diagram

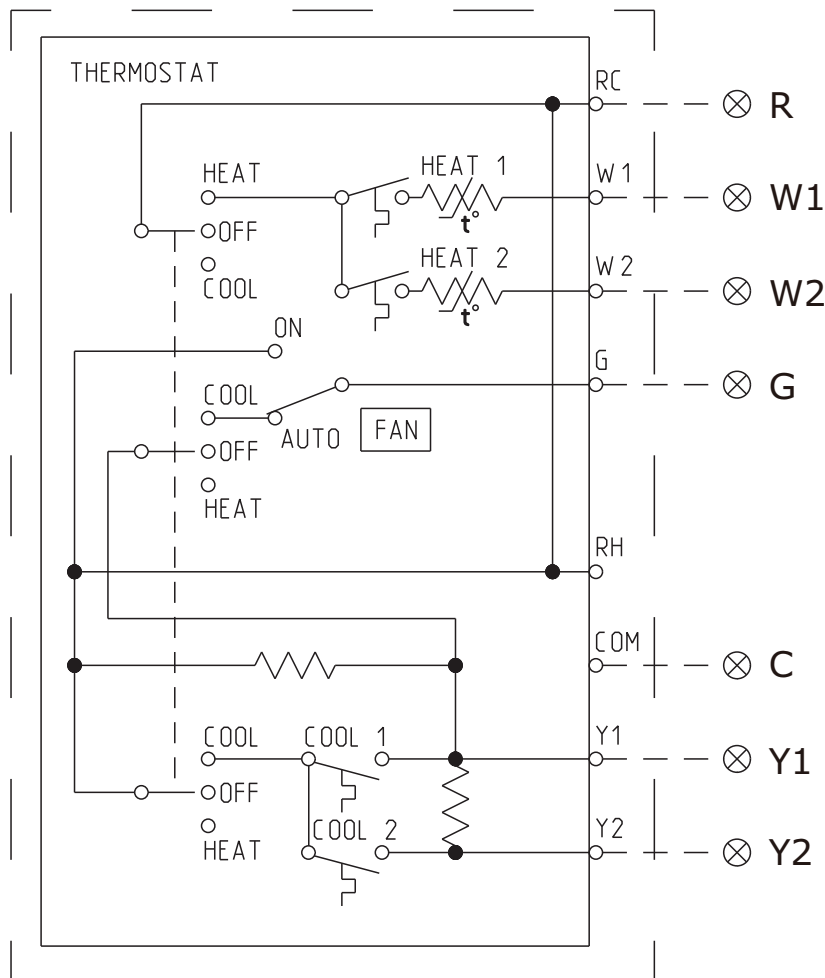

Gas Heat Data

Table 5. Gas heater operating data

Heating Input Rate —Btu/h	125,000	180,000	225,000	250,000
Minimum Supply Gas Pressure Natural/LP	4.5/11.0	4.5/11.0	4.5/11.0	4.5/11.0
Manifold Gas Pressure ^(a)	3.5	3.9	3.6	3.5
Combustion Blower Suction Pressure (1 st Stage)	-1.3 to -1.7	-1.3 to -1.7	-1.1 to -1.5	-1.1 to -1.5
Combustion Blower Suction Pressure (2 nd Stage)	-1.3 to -1.7	-1.3 to -1.7	-1.1 to -1.5	-1.1 to -1.5
Minimum Flame Sensing Current ^(b)	5.0 Micro Amps DC			
Normal Sensing Current Range	8.0 to 16 Micro Amps DC			
Flue Gas Temperature Rise Above Ambient	230 to 300 F			
Flue Gas Content - % CO ₂	7.0% to 8.0% (Natural Gas) 7.5% to 9.0% (Propane)			
Minimum Supply Air Temperature Across Heat Exchanger	40° F			

^(a) Staged gas heat units have a positive pressure gas valve. Never adjust the staged gas pressure valve to a negative pressure.

^(b) A voltage reading across pens (V+) and (V-) is equatable to the flame sensing current. One volt equals one micro amp.

Table 6. Piping

Length of Pipe (ft)	Iron Pipe Size (IPS) Inches				
	1/2" Pipe	3/4" Pipe	1" Pipe	1 1/4" Pipe	1 1/2" Pipe
15	76	176	345	750	1220
30	52	120	241	535	850
45	43	99	199	435	700
60	38	86	173	380	610
75	35	77	155	345	545

Note: Capacity of Pipe of Different Diameters and Lengths in Cu. Ft. Per Hr. with Pressure Drop of 0.3" and Specific Gravity of 0.60.

Table 7. Specific gravity multipliers

Specific Gravity	Multipliers
0.50	1.10
0.55	1.04
0.60	1.00
0.65	0.96

Figure 12. Schematic diagram for field gas piping to units

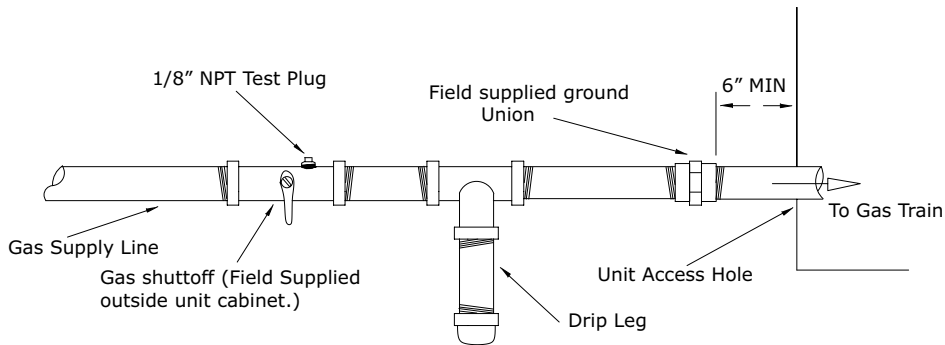
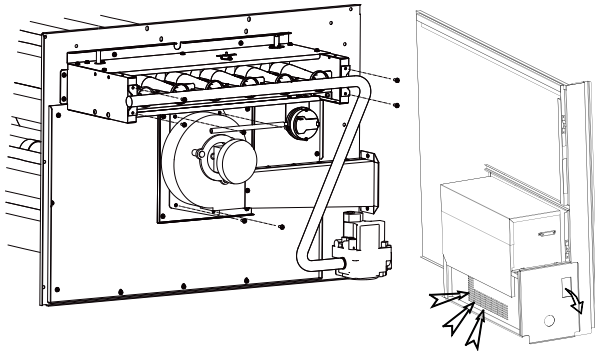

Figure 13. Typical unit gas train configuration



Combustion Airflow Path and Exhaust Path should keep open for heating.

Voltage Imbalance

Three phase electrical power to the unit must meet stringent requirements for the unit to operate properly. Measure each leg (phase-to-phase) of the power supply.

Each reading must fall within the utilization range stamped on the unit nameplate. If any of the readings do not fall within the proper tolerances, notify the power company to correct this situation before operating the unit.

Excessive three phase voltage imbalance between phases will cause motors to overheat and eventually fail. The maximum allowable voltage imbalance is 2 percent.

Measure and record the voltage between phases 1, 2, and 3 and calculate the amount of imbalance as follows:

% Voltage Imbalance = $(100 \times (AV - VD)) / AV$ where;

- V1, V2, V3 = Line voltage readings
- AV (Average Voltage) = $(V1 + V2 + V3) / 3$
- VD = Line voltage reading that deviates the farthest from the average voltage

Example:

The supply power line voltage readings (V1, V2, V3) are 221, 230, and 227 respectively.:

- AV (Average Voltage) = $(221 + 230 + 227) / 3 = 226$ Avg.
- VD (reading farthest from average) = 221
- % Voltage Imbalance = $(100 + 226 + 221) / 226 = 2.2\%$

The 2.2 percent imbalance in this example exceeds the maximum allowable imbalance of 2.0 percent. This much imbalance between phases can equal as much as a 20 percent current imbalance with a resulting increase in motor winding temperatures that will decrease motor life.

If the voltage imbalance is over 2 percent, notify the proper agencies to correct the voltage problem before operating this equipment.

Electrical Phasing (Three Phase Motors)

The compressor motor(s) and the supply fan motor are internally connected for the proper rotation when the incoming power supply is phased as A, B, C.

Proper electrical supply phasing can be quickly determined and corrected before starting the unit by using an instrument such as an Associated Research Model 45 Phase Sequence Indicator and following the steps below:

⚠ WARNING

Hazardous Voltage!

Failure to disconnect power before servicing could result in death or serious injury.

Disconnect all electric power, including remote disconnects before servicing. Follow proper lockout/tagout procedures to ensure the power can not be inadvertently energized. Verify that no power is present with a voltmeter.

1. Turn the field supplied disconnect switch that provides power to the main power terminal block or to the "Line" side of the optional factory mounted disconnect switch to the "Off" position.
2. Connect the phase sequence indicator leads to the terminal block or to the "Line" side of the optional factory mounted disconnect switch as follows:
 - Black (phase A) to L1
 - Brown (phase B) to L2
 - Gray (phase C) to L3
3. Close the field supplied main power disconnect switch or circuit protector switch that provides the supply power to the unit.

⚠ WARNING

Live Electrical Components!

Failure to follow all electrical safety precautions when exposed to live electrical components could result in death or serious injury.

When it is necessary to work with live electrical components, have a qualified licensed electrician or other individual who has been properly trained in handling live electrical components perform these tasks.

4. Observe the ABC and CBA phase indicator lights on the face of the sequencer. The ABC indicator light will glow if the phase is ABC. If the CBA indicator light glows, open the disconnect switch or circuit protection switch and reverse any two power wires.
5. Restore the main electrical power and recheck the phasing. If the phasing is correct, open the disconnect switch or circuit protection switch and remove the phase sequence indicator.

Checklist

Use the following checklist in conjunction with the general checklist (“,”) to ensure that the unit is properly installed and ready for operation.

⚠ WARNING

Hazardous Voltage!

Failure to disconnect power before servicing could result in death or serious injury.

Disconnect all electric power, including remote disconnects before servicing. Follow proper lockout/tagout procedures to ensure the power can not be inadvertently energized. Verify that no power is present with a voltmeter.

- Check all electrical connections for tightness and “point of termination” accuracy.
- Verify that the condenser airflow is unobstructed.
- Verify that the condenser fan and indoor blower turn freely without rubbing and are properly tightened on the shafts.
- Check the supply fan belts for proper tension and the fan bearings for sufficient lubrication. If the belts require adjustment, or if the bearings need lubricating, refer to the maintenance section of this manual for instructions.
- Verify that a condensate trap is installed and the piping is properly sized and pitched.
- Verify that the correct size and number of filters are in place.
- Inspect the interior of the unit for tools and debris and install all panels in preparation for starting the unit.

External Unit Power Supply

Unit Disconnect Wiring Plan

⚠ WARNING

Proper Field Wiring and Grounding Required!

Failure to follow code could result in death or serious injury.

All field wiring MUST be performed by qualified personnel. Improperly installed and grounded field wiring poses FIRE and ELECTROCUTION hazards. To avoid these hazards, you MUST follow requirements for field wiring installation and grounding as described in NEC and your local/state/national electrical codes.

Important: All phases of this installation must comply with NATIONAL, STATE, and LOCAL CODES. In addition to local codes, the installation must comply with National Electric Code - ANSI/NFPA NO. 70 LATEST REVISION.

1. Field connections are made by first removing the compressor access panel on the front of the unit. Unscrew the assembly around the outside of the disconnect switch. This assembly is located in the condenser section of the unit.

Both high and low voltage power can be routed through the base or through the front corner post where the disconnect enclosure is mounted. The hole is sized for 1 1/2-in. conduit.
2. If the conduit required for your application is larger than 1 1/2-in., remove the termination plate and connect to the larger hole using field supplied reducing washers.
3. Route the power wires and ground conductor through conduit and into the bottom of a field installed disconnect switch. Connect the power conductors to the lugs provided. Connect the ground wire to the unit ground lug.

Note: Wire size for the length of run should be determined using the circuit ampacity found on the unit nameplate and the N.E.C.
4. Route low voltage (class II), control wiring through hole in base of unit but not through high voltage conduit. Feed control wiring through bushing provided on side panel. Route wires through loose wire ties provided.
5. Tighten the wire ties. Secure the excess wire bundle under the wire ties in the outdoor section. Do not leave excess wire in the electrical enclosure. Use the unit wiring diagram to make the low voltage connections.

Through-the-Base Gas Utility Option

Field Installed Connections

This section contains the instructions for making field connections to the through-the-base gas utility option.

⚠ WARNING

Hazardous Voltage w/Capacitors!

Failure to disconnect power and discharge capacitors before servicing could result in death or serious injury.

Disconnect all electric power, including remote disconnects and discharge all motor start/run capacitors before servicing. Follow proper lockout/tagout procedures to ensure the power cannot be inadvertently energized. Verify with a CAT III or IV voltmeter rated per NFPA 70E that all capacitors have discharged.

⚠ WARNING

Proper Field Wiring and Grounding Required!

Failure to follow code could result in death or serious injury.

All field wiring **MUST** be performed by qualified personnel. Improperly installed and grounded field wiring poses **FIRE** and **ELECTROCUTION** hazards. To avoid these hazards, you **MUST** follow requirements for field wiring installation and grounding as described in NEC and your local/state/national electrical codes.

Important: All phases of this installation must comply with **NATIONAL, STATE, and LOCAL CODES**. In absence of local codes, the installation must conform with **ANSI Z223.1/NFPA 54**, and/or the **Natural Gas and Propane Installation Code, CSA B149.1**.

1. Field connections are made by first removing the access panel for the heat section on the front of the unit.
2. The gas piping assembly ships inside this section and includes the shut-off valve, a pressure tap for testing, and the necessary unions for field connection. For through the base access, remove the factory-provided cap from the base pan opening. See [Figure 14](#), p. 31.
3. Route field piping through this hole to the dimension shown in [Table 8](#), p. 31.
4. Place the assembly through the cabinet opening as shown in and make the union connection to the field piping and to the gas train. Refer to the "[Heating Operation \(for Gas Units\) - Standard Economizer](#)," p. 36 for start-up instructions.

Table 8. Through the base gas piping dimension

Model	Dimension
GDK090-150	1 3/16-in.

Figure 14. Through the base gas piping installation

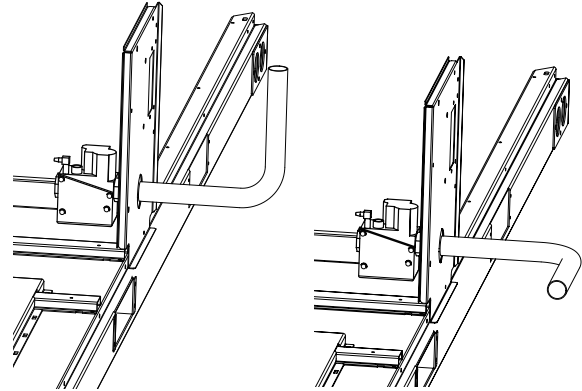

Note: When installing gas pipelines, if flue gas temperature is high, avoid flue gas to directly blow to the gas pipelines.

Refrigerant Sensor

Important:

- *When there is a leak, the electric heater will stop. When the refrigerant sensor detects a refrigerant leak, the device shuts down the compressor, external motor, electric auxiliary heat or gas heating, and starts the internal fan to run at the highest speed, and the digital tube displays X.PL.*
- *When the main control cannot communicate with the refrigerant sensor, the device shuts down the compressor, external motor, electric auxiliary heat or gas heating, and starts the internal fan to run at the highest speed and the digital tube displays X.Ed.*
- *When the main control reads the life fault information of the refrigerant sensor, the device shuts down the compressor, external motor, electric auxiliary heat or gas heating, and starts the internal fan to run at the highest speed, and the digital tube displays X.EH. In this case, you need to replace a correct sensor in time.*
- *When the main control reads that the refrigerant sensor has other fault information, the device shuts down the compressor, external motor, electric auxiliary heat or gas heating, and starts the internal fan to run at the highest speed, and the digital tube displays X.EL. X is 1/2, 1 represents the inside sensor, and 2 represents the outside sensor.*

⚠ WARNING

Faulty Codes!

Failure to follow proper R-454B mitigation system installation instructions could result in death or serious injury or property damage.

Troubleshoot any listed faulty codes to prevent system malfunction.

⚠ WARNING

Leak Detection System Installed!

Failure to follow instructions below could result in death or serious injury or equipment damage.

The unit is equipped with electrically powered safety measures and must be powered at all times after installation, except during servicing, to detect any leak.

- The refrigerant leakage sensor can only use the factory model or the specified model indicated in the corresponding manual.
- The R454B refrigerant leakage sensor must be used to activate the refrigerant shut-off device, the alarm device, incorporated circulation airflow, or other emergency controls, which gives an electrical signal at a predetermined alarm set point in response to leaked refrigerant.
- The installation of the refrigerant leakage sensor allows access for checking, repair, or replacement by an authorized person. Function of the refrigerant leakage sensor can be verified easily.
- The refrigerant leakage sensor is protected to prevent tampering or unauthorized resetting of the pre-set value.
- To be effective, the refrigerant leakage sensor must be electrically powered at all times after installation, other than when servicing.
- Refrigerant sensor must be replaced after its service life (15 years) or if the sensor is determined to be faulty during the service life.

NOTICE

Compressor Damage!

Failure to follow instructions below could result in the fan to turn on to maximum and stop the compressor resulting in the compressor failure.

If the refrigerant leakage sensor detects a refrigerant leak, you must immediately leave the leak area and notify a professional.

Figure 15. Refrigerant sensor installation position (1–inside; 2–outside)

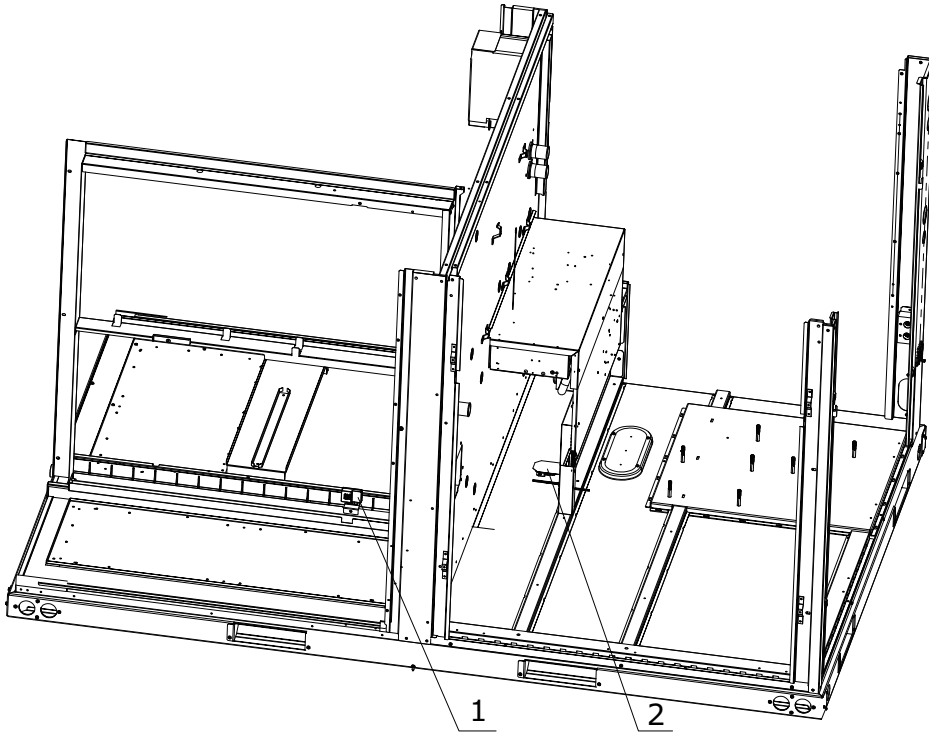

Pre Start

Verifying Proper Air Flow (Units with Belt Drive Indoor Fan)

Much of the systems performance and reliability is closely associated with, and dependent upon having the proper airflow supplied both to the space that is being conditioned and across the evaporator coil.

The indoor fan speed is changed by opening or closing the adjustable motor sheave.

Before starting the SERVICE TEST, set the minimum position setpoint for the economizer to 0% using the setpoint potentiometer located on the Economizer Control (ECA), if applicable.

⚠ WARNING

Risk of Fire or Explosion!

Failure to follow instructions below could cause a fire or explosion which could result in death or serious injury, and equipment damage.

Never test for gas leaks with an open flame. Use a commercially available soap solution made specifically for the detection of leaks to check all connections. A fire or explosion may result causing property damage, personal injury, or loss of life.

Electromechanical Controls – Test Procedure

Fan Test and Minimum Ventilation. Connect the short circuit between R and G.

Connect the short circuit between R and Y1.

Cool 1. Connect the short circuit between R and Y1.

Cool 2. Connect the short circuit between R and Y2.

Heat 1. Connect the short circuit between R and W1.

Heat 2. Connect the short circuit between R and W2.

Start-Up

Electromechanical Controls - Sequence Of Operation

These units are offered with electromechanical controls.

Cooling without an Economizer

When the thermostat switch is set to the "Cool" position and the zone temperature rises above the cooling setpoint, the thermostat Y contacts close. The compressor contactor (CC1) coil is energized provided the low pressure control (LPC1), high pressure control (HPC1) and discharge line thermostat (DLT 1) are closed. When the (CC1) contacts close, compressor (CPR1) and both outdoor fan motors (ODM1 and ODM2) start. If the first stage of cooling cannot satisfy the cooling requirement, the thermostat closes Y2. The compressor contactor (CC2) coil is energized provided the low pressure control (LPC2), high pressure control (HPC2) and discharge line thermostat (DLT 2) are closed.

When the (CC2) contacts close, compressor (CPR2) starts.

Evaporator Fan Operation (for Gas Units) - Standard Economizer

Economizer is a field installed accessory. Refer to the following economizer information when the accessory kit is installed.

When the thermostat fan selection switch is set to the "Auto" position, the Ignition Module (IGN) energizes the indoor fan relay (F) approximately 1 second after energizing the compressor contactor coil (CC1) in the cooling mode. In the heating mode, the Ignition Module (IGN) energizes the indoor fan relay (F) coil approximately 45 second after gas ignition. Closing indoor fan relay (F) coil starts the indoor fan motor (IDM). The (IGN) de-energizes the fan relay (F) approximately 80 seconds after the cooling requirement has been satisfied to enhance unit efficiency.

When the heating cycle is terminated, the indoor fan relay (F) coil is de-energized approximately 90 seconds after the heating requirement.

When the thermostat fan selection switch is set to the "On" position, the (IGN) keeps the indoor fan relay coil (F) energized for continuous fan motor operation.

Evaporator Fan Operation (for Cooling Only Units) - Standard Economizer

When the thermostat fan selection switch is set to the "Auto" position, the thermostat energizes the indoor fan relay coil (F) to start the indoor fan motor (IDM). The fan relay (F) de-energizes after the cooling requirement has been satisfied. When the heating cycle is terminated, the indoor fan relay (F) coil is de-energized with heater contactors.

When the thermostat fan selection switch is set to the "On" position, the thermostat keeps the indoor fan relay coil (F) energized for continuous fan motor operation.

Economizer Set-Up - Standard Economizer

Adjusting the minimum position potentiometer located on the unit economizer module (RTEM-EM) sets the required amount of ventilation air.

Ambient temperature is controlling the economizing cycle by sensing the outside air dry bulb temperature. [Table 9, p. 35](#) lists the selectable dry bulb values by potentiometer setting.

Table 9. Potentiometer settings

Potentiometer Setting	Dry Bulb	Enthalpy
A	27 Btu/lb (63 kJ/kg)	73°F (22.8°C)
B	25 Btu/lb (58 kJ/kg)	70°F (21.1°C)
C ^(a)	23 Btu/lb (53 kJ/kg)	67°F (19.4°C)
D	22 Btu/lb (51 kJ/kg)	63°F (17.2°C)
E	19 Btu/lb (44 kJ/kg)	55°F (12.8°C)

^(a) Factory setting

Cooling with an Economizer - Standard Economizer

The economizer is utilized to control the zone temperature providing the outside air conditions are suitable. Outside air is drawn into the unit through modulating dampers.

When cooling is required and economizing is possible, the unit economizer module (RTEM-EM) opens the economizer damper. The RTEM-EM continues to modulate the economizer damper open/closed to keep the mixed air temperature in the 50°F to 55°F range.

The thermostat will close the Y2 contacts to turn on contactor (CC1) if mechanical cooling is required.

If economizing is not possible, the RTEM-EM drives the damper to the minimum position setpoint when the indoor fan relay (F) is energized and allows mechanical cooling operation.

Heating Operation (Units with Electric Heat) - Standard Economizer

When the system switch is set to the "Heat" position and the zone temperature falls below the heating setpoint, the thermostat closes W1 contacts the first stage electric heat contactor (AH or AH and CH) is energized. If the first stage of electric heat cannot satisfy the heating requirement, the thermostat closes W2.

When the W2 contacts close, the second stage electric heat contactor (BH or BH and DH) is energized, if applicable. The thermostat cycles both the first and second stages of heat "On" and "Off" as required to maintain the zone temperature setpoint.

Heating Operation (for Gas Units) - Standard Economizer

When the system switch is set to the "Heat" position and the zone temperature falls below the heating setpoint, the Ignition module (IGN) initiates a heat cycle.

Ignition Module Low, Medium and High Heat

Two-stage (IGN) runs self-check (including verification that the gas valve is de-energized). (IGN) checks the high-limit switches (TC01 and TC01) for normally closed contacts, the pressure switch (PS) for normally open contacts, and the flame rollout (FR) switch for continuity. (IGN) energizes inducer blower on high speed to check pressure switch closure. If the pressure switch is closed, the inducer blower starts a 20 second pre-purge (15 seconds on high speed followed by 5 seconds on low speed).

If the pressure switch (PS) is still open, the inducer blower will continue to be energized on high speed until pressure switch closure.

After pre-purge completes, the (IGN) energizes the first stage of the gas valve, initiates spark for 2 seconds minimum, 7 seconds maximum (ignition trial) and detects flame and de-energizes spark. From this point, a fixed 45 second indoor blower delay on timing starts.

After the indoor blower delay on is completed, the (IGN) energizes the indoor blower. The (IGN) enters a normal operating loop where all inputs are continuously monitored. If the first stage of gas heat cannot satisfy the heating requirement, the thermostat closes W2. The (IGN) energizes the second stage of the gas valve and the second stage of inducer blower.

When the zone thermostat is satisfied, the (IGN) de-energizes the gas valve. The (IGN) senses loss of flame. The (IGN) initiates a 5 second inducer blower post purge and 90 second indoor blower delay off at current speed. The (IGN) de-energizes the inducer blower at the end of the post purge. The (IGN) de-energizes the indoor blower at the end of the selected indoor blower delay off.

Table 10. Ignition module diagnostics

Slow Flash	Normal, call for heat.
Two blinks	System lockout (failure to detect or sustain flame).
Three blinks	Pressure switch problem detected.
Four blinks	High Limit Switch protection device open.
Five blinks	Flame sensed and Gas Valve not energized or flame sensed and no 'W' signal.

Table 10. Ignition module diagnostics (continued)

Six blinks	Flame Rollout Switch open.
Seven blinks	Switch open (W1 and W2 swapped).

Two-Speed Indoor Fan Control

For units equipped with two-speed indoor fan control, standard unit operation for cooling and heating will continue and all unit functions will operate normally, except for the control of the indoor fan speed. All units configured with any type of heating will heat the supply air and space as normal utilizing full speed indoor fan by energizing the appropriate outputs. The two-speed indoor fan unit will only utilize two speeds during the cooling operation modes described below.

Cooling Operation

For cooling operation, the unit will operate at Low Fan Speed during Fan Only, Economizer Only, and the first stage of compressor unit modes by Default. When the unit receives a call for cooling, if the economizer is enabled, the unit will energize the associated Low Speed output and begin to modulate the OA Damper open above minimum position up to 100% as necessary. By default, the supply fan will remain at low speed for the duration of Economizer-Only cooling. If the supply fan is on when the first stage compressor is energized, it will remain energized or energize at low speed for the duration of Cool 1.

When there is a call for Cool 2, the second compressor is energized and the Supply Fan will switch to High Speed.

The unit will stage down compressors for cooling in reverse order that they were staged and the supply fan will follow the unit mode transitions. Once it is determined through normal cooling control that the second compressor is no longer necessary to meet cooling demand, the second compressor will be staged back and the supply fan will switch to Low Speed until the unit stages all cooling off or receives a call for Cool 2 again. Once the Supply Fan is no longer requested ON after a Cooling call is cleared, the Supply Fan will remain energized at Low Speed for 60 seconds as on traditional units.

If the economizer is enabled and is being utilized as the first stage of cooling (Y1 active), if the unit receives a Y2 request, the unit will energize the first compressor and will switch the supply fan to high speed until the Y2 request is cleared.

Low Pressure Cutout

The low pressure cutouts are wired in series with the high pressure cutouts and the temperature discharge limits. If this circuit is open before a compressor is started, the compressor in that circuit will not be allowed to operate.

Anytime this circuit is opened, the compressor in that circuit is turned off immediately.

High Pressure Cutout and Temperature Discharge Limit

The high pressure controls and temperature discharge limit are wired in series between the compressor outputs on the LTB and the compressor contactors. If the high pressure safety or temperature discharge limit opens, the compressor on the affected circuit is turned off.

Heating Operation

Standard unit operation for heating will continue on units equipped with a two-speed indoor fan. During heat mode, all units configured with staged electric or gas heat will heat the supply air and space as normal utilizing full speed indoor fan.

Emergency Stop

This input can be activated by opening a field-supplied device.

Compressor Start-Up

1. Attach a set of service gauges onto the suction and discharge gauge ports for each circuit.

See, "Cooling Operation," p. 36 for start-up instructions.

Scroll Compressors

- Once each compressor has started, verify that the rotation is correct. If wired correctly the suction pressure should drop and the discharge pressure should rise. If a scroll compressor is rotating backwards, it will not pump and a loud rattling sound can be observed.
- Once each compressor has started, verify that the rotation is correct. If wired correctly the suction pressure should drop and the discharge pressure should rise. If a scroll compressor is rotating

backwards, it will not pump and a loud rattling sound can be observed.

Figure 16. Compressor terminal box

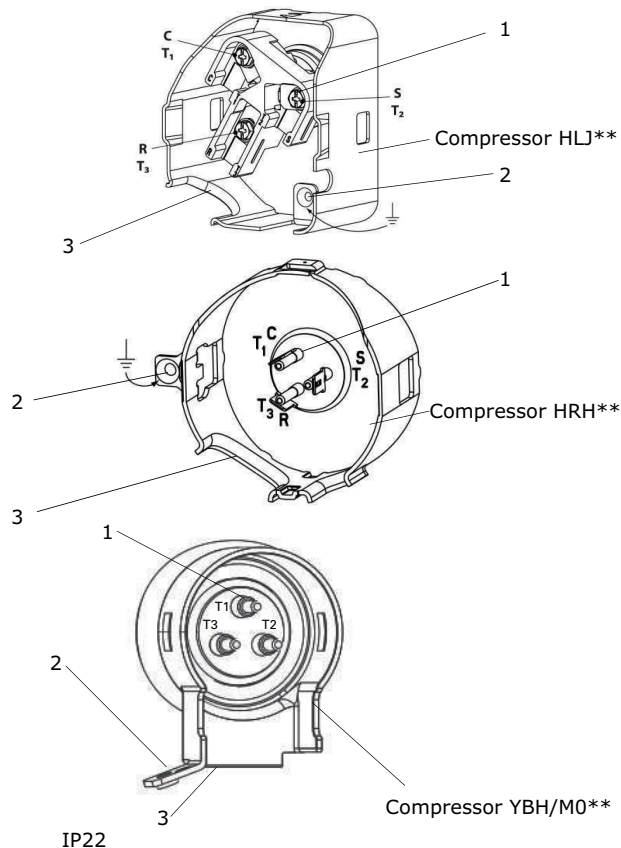

- 1 – Spade connectors 1/4-in.
- 2 – Earth connection
- 3 – Power cable passage

Table 11. Compressor types

Tonnage	208/230V		460V	
	Compressor 1	Compressor 2	Compressor 1	Compressor 2
E/GD*090	YBH042R	YBH031R	YBH042W	YBH031W
E/GD*102	YBM051R	YBH042R	YBM051W	YBH042W
E/GD*120	YBM051R	HRH051U2	HBM051W	HRH051U4
E/GD*150	HLJ072U2	YBM051R	HLJ072U4	YBM051W

Table 12. POE Oil recharge amount (fl. oz.)

Tonnage	208/230V		460V	
	Compressor 1	Compressor 2	Compressor 1	Compressor 2
E/GD*090	43.3	25.0	43.3	25.0
E/GD*102	43.3	43.3	43.3	43.3

Start-Up

Table 12. POE Oil recharge amount (fl. oz.) (continued)

Tonnage	208/230V		460V	
	Compressor 1	Compressor 2	Compressor 1	Compressor 2
E/GD*120	43.3	53.1	43.3	53.1
E/GD*150	53.1	43.3	53.1	43.3

- After the compressor and condenser fan have started and operated for approximately 30 minutes, observe the operating pressures. Compare the operating pressures to the operating pressure curve..
- Check system subcooling.
- Repeat Step 1 through Step 3 for each refrigerant circuit.
- To stop the SERVICE TEST, turn the main power disconnect switch to the "Off" position or proceed to the next component start-up procedure. Remove electromechanical test mode connections (if applicable).

Heating Start-Up

When starting the unit for the first time or servicing the heaters, it is a good practice to start the heater with the main gas supply turned "Off". Once the ignition system and components have been checked, open the main power disconnect switch to reset the unit.

Table 13. Maximum Refrigerant Charge

A/TA		Mmax	
ft ²	m ²	lb-oz	kg
40	3.7	2-10	1.2
50	4.6	3-5	1.5
60	5.6	4-0	1.8
70	6.5	4-10	2.1
80	7.4	5-5	2.4
90	8.4	6-0	2.7
100	9.3	6-10	3.0
110	10.2	7-5	3.3
120	11.1	8-0	3.6
130	12.1	8-10	3.9
140	13	9-5	4.2
150	13.9	10-0	4.5
160	14.9	10-10	4.8
170	15.8	11-5	5.1
180	16.7	12-0	5.4
190	17.7	12-10	5.7
200	18.6	13-5	6.0

Final System Setup

After completing all of the pre-start and start-up procedures outlined in the previous sections (i.e., operating the unit in each of its modes through all available stages of cooling and heating), perform these final checks before leaving the unit:

- Inspect the unit for misplaced tools, hardware, and debris.
- Verify that all exterior panels including the control panel doors and condenser grilles are secured in place.
- Close the main disconnect switch or circuit protector switch that provides the supply power to the unit's terminal block or the unit mounted disconnect switch.

Refrigerant Charge and Room Area Limitations

For more information on refrigerant charge and room area requirements/limitations refer to "A2L Information," p. 18.

Table 13. Maximum Refrigerant Charge (continued)

A/TA		Mmax	
ft ²	m ²	lb-oz	kg
210	19.5	14-0	6.3
220	20.4	14-10	6.6
230	21.4	15-5	6.9
240	22.3	16-0	7.2
250	23.2	16-10	7.5
260	24.2	17-5	7.8

Table 14. Minimum circulation airflow

mc		Qmin	
lb-oz	kg	CFM	m ³ /h
4-6	2	119	202.7
4-13	2.2	131	223.0
5-4	2.4	143	243.2
5-11	2.6	155	263.5
6-2	2.8	167	283.8
6-9	3	179	304.1
7-0	3.2	191	324.3
7-7	3.4	203	344.6
7-15	3.6	215	364.9
8-6	3.8	227	385.1
8-13	4	238	405.4
9-4	4.2	250	425.7
9-11	4.4	262	445.9
10-2	4.6	274	466.2
10-9	4.8	286	486.5
11-0	5	298	506.8
11-7	5.2	310	527.0
11-14	5.4	322	547.3
12-5	5.6	334	567.6
12-12	5.8	346	587.8
13-3	6	358	608.1
13-10	6.2	370	628.4
14-1	6.4	382	648.6
14-8	6.6	393	668.9
14-15	6.8	405	689.2
15-6	7	417	709.5
15-14	7.2	429	729.7
16-5	7.4	441	750.0

Start-Up

Table 14. Minimum circulation airflow (continued)

mc		Qmin	
lb-oz	kg	CFM	m ³ /h
16-12	7.6	453	770.3
17-3	7.8	465	790.5

Table 15. Refrigerant charge limit

Model (Tons)	mc/kg	TAmin
7.5	1.7 (system A)	5.2
8.5	1.95 (system A)	6.0
10	2.3 (system A)	7.1
12.5	3 (system A)	9.2

Table 16. Minimum effective dispersal volume

Mc		VED	
lb-oz	kg	ft ³	m ³
4-6	2	477	13.5
4-13	2.2	525	14.9
5-4	2.4	573	16.2
5-11	2.6	620	17.6
6-2	2.8	668	18.9
6-9	3	716	20.3
7-0	3.2	764	21.6
7-7	3.4	811	23.0
7-15	3.6	859	24.3
8-6	3.8	907	25.7
8-13	4	954	27.0
9-4	4.2	1002	28.4
9-11	4.4	1050	29.7
10-2	4.6	1098	31.1
10-9	4.8	1145	32.4
11-0	5	1193	33.8
11-7	5.2	1241	35.1

Table 16. Minimum effective dispersal volume (continued)

Mc		VED	
lb-oz	kg	ft ³	m ³
11-14	5.4	1289	36.5
12-5	5.6	1336	37.8
12-12	5.8	1384	39.2
13-3	6	1432	40.5
13-10	6.2	1479	41.9
14-1	6.4	1527	43.2
14-8	6.6	1575	44.6
14-15	6.8	1623	45.9
15-6	7	1670	47.3
15-14	7.2	1718	48.6
16-5	7.4	1766	50.0
16-12	7.6	1813	51.4
17-3	7.8	1861	52.7

Important Service Precautions

⚠ WARNING

Hazardous Service Procedures!

Failure to follow all precautions in this manual and on the tags, stickers, and labels could result in death or serious injury.

Technicians, in order to protect themselves from potential electrical, mechanical, and chemical hazards, **MUST** follow precautions in this manual and on the tags, stickers, and labels, as well as the following instructions: **Unless specified otherwise, disconnect all electrical power including remote disconnect and discharge all energy storing devices such as capacitors before servicing. Follow proper lockout/tagout procedures to ensure the power can not be inadvertently energized. When necessary to work with live electrical components, have a qualified licensed electrician or other individual who has been trained in handling live electrical components perform these tasks.**

While changing electrical components, they must fit according to their purpose and to the correct specification. Refer to manufacturer's maintenance and service guidelines or consult the manufacturer's technical department for assistance.

The following checks must be applied during installations using flammable refrigerants:

- The actual refrigerant charge is in accordance with the room size within which the refrigerant containing parts are installed.
- The ventilation machinery and outlets are operating adequately and are not obstructed.
- If an indirect refrigerating circuit is being used, the secondary circuit must be checked for the presence of refrigerant.
- Equipment marking must remain visible and legible. Illegible markings and signs must be corrected.

Refrigerating pipe or components are installed in a way that they are not exposed to any substances which may corrode refrigerant containing components, unless the components are constructed of materials that are inherently resistant to corrosion or are suitably protected against corrosion.

Repair and maintenance of electrical components must include initial safety checks and component inspection procedures. If there is a fault causing issue, do not connect any electrical supply to the circuit until the fault is corrected. If the fault cannot be corrected immediately but it is necessary to continue operation, an adequate temporary solution must be used. This must be reported to the equipment owner so that all parties are advised.

Following initial safety checks must be included:

- Capacitors must be discharged in a safe manner to avoid the possibility of sparking.

- No live electrical components and wiring must be exposed while charging, recovering, or purging the system.
- There must be continuity of earthing.

Sealed electrical components and Intrinsically safe components must be replaced.

Cabling must not subject to wear, corrosion, excessive pressure, vibration, sharp edges, continual vibration from sources such as compressors or fans, or any other adverse environmental effects.

Potential sources of ignition (A halide torch or any other detector using a naked flame) must not be used while detecting/searching refrigerant leaks.

Electronic leak detectors may be used to detect refrigerant leaks but, in the case of flammable refrigerants, the sensitivity may not be adequate, or may need re-calibration. (Detection equipment must be calibrated in a refrigerant-free area.) Verify that the detector is not a potential source of ignition and is suitable for the refrigerant used. Leak detection equipment must be set at a percentage of the LFL of the refrigerant and calibrated for the refrigerant employed, and the appropriate percentage of gas (25% maximum) must be confirmed.

If a leak is suspected, all naked flames must be removed/ extinguished. If a refrigerant leak which requires brazing is found, all the refrigerant must be recovered from the system, or isolated (by means of shut off valves) in a part of the system remote from the leak.

Leak detection fluids can be used with most refrigerants but avoid using detergents containing chlorine as the chlorine may react with the refrigerant and corrode the copper pipe-work. Examples of leak detection fluids are bubble method and fluorescent method agents.

When breaking into the refrigerant circuit to make repairs—or for any other purpose—use conventional procedures. For flammable refrigerants follow best practices. Adhere to the following steps:

1. Remove refrigerant safely following local and national regulations.
2. Evacuate.
3. Purge the circuit with inert gas.
4. Evacuate.
5. Continuously flush or purge with inert gas when using flame to open circuit.
6. Open the circuit.

Recover the refrigerant charge into the correct recovery cylinders if venting is not allowed by local and national codes. For appliances containing flammable refrigerants, purge the system with oxygen-free nitrogen to render the appliance safe for flammable refrigerants. If needed, repeat the process several times.

Important: Do Not use compressed air or oxygen for purging refrigerant systems.

For appliances containing flammable refrigerants, purge refrigerants by breaking the vacuum in the system with oxygen-free nitrogen and continuing to fill until the working pressure is achieved, then venting to atmosphere, and finally pulling down to a vacuum. Repeat this process until there is no refrigerant within the system. When the final oxygen-free nitrogen charge is used, vent down the system to atmospheric pressure to enable working conditions.

Important: Confirm that the outlet for the vacuum pump is not close to any potential ignition sources and that there is proper ventilation.

Confirm that different refrigerants are not contaminated when using charging equipment.

Hoses or lines must be as short as possible to minimize the amount of refrigerant they contain.

Keep cylinders upright and verify that the refrigeration system is grounded prior to charging the system with refrigerant.

Label the system when charging is complete (if it is not already labeled). Do Not overfill the refrigeration system.

Before recharging the system, pressure-test with appropriate purging gas. Leak-test the system when charging is complete and before commissioning. Carry a follow up leak test before leaving the site.

Important:

- Before carrying out this procedure, it is essential that the technician is completely familiar with the equipment and all its detail.
- It is recommended that all refrigerants are recovered safely.
- Prior to the task being carried out, secure an oil and refrigerant sample in case analysis is required prior to re-use of reclaimed refrigerant.
- Electric power must be available before the task is commenced.

1. Familiarize with the equipment and its operation.
2. Isolate system electrically.
3. Before attempting the procedure verify:
 - Mechanical handling equipment is available, if required, for handling refrigerant cylinders.
 - All personal protective equipment is available and being used correctly.
 - Recovery process is supervised at all times by a competent person.
 - Recovery equipment and cylinders conform to the appropriate standards.
4. Pump down refrigerant system, if possible.

5. If a vacuum is not possible, make a manifold so that refrigerant can be removed from various parts of the system.
6. Verify that the cylinder is situated on the scales before recovery takes place.
7. Start the recovery machine and operate it in accordance with the manufacturer's instructions.
8. Do not overfill cylinders. (Not more than 80% volume liquid charge).
9. Do not exceed the maximum working pressure of the cylinder, even temporarily.
10. When the cylinders have been filled correctly and the process has been completed, confirm that the cylinders and the equipment are removed from site promptly and all isolation valves on the equipment are closed off.
11. Do not charge recovered refrigerant into another refrigeration system unless it has been cleaned and checked.

Label the equipment stating that it has been de-commissioned and refrigerant emptied. The label must be dated and signed. Verify that there are labels on the equipment stating the equipment contains flammable refrigerant.

When removing refrigerant from a system, either for servicing or decommissioning, it is recommended that all refrigerants are removed safely.

When transferring refrigerant into cylinders, confirm the following:

- Only appropriate refrigerant recovery cylinders are employed.
- Correct number of cylinders for holding the total system charge is available.
- All cylinders to be used are designated for the recovered refrigerant and labelled for that refrigerant (for example special cylinders for the recovery of refrigerant).
- Cylinders are complete with pressure-relief valve and associated shut-off valves are in good working conditions.
- Empty recovery cylinders are evacuated and, if possible, cooled before recovery occurs.

The recovery equipment must be in good working conditions with a set of instructions concerning the equipment that is at hand and must be suitable for the recovery of the flammable refrigerant. Consult the manufacturer for any questions. In addition, a set of calibrated weighing scales must be available and in good working conditions. Hoses must be complete with leak-free disconnect couplings and in good condition.

Process the recovered refrigerant according to local legislation in the correct recovery cylinder, arrange the relevant waste transfer note. Do Not mix refrigerants in recovery units and especially in cylinders.

If compressors or compressor oils need to be removed, confirm that they have been evacuated to an acceptable level to avoid any flammable refrigerant within the lubricant.

The compressor body must not be heated by an open flame or other ignition sources to accelerate this process.
Drain oil from a system safely.

Maintenance

⚠ WARNING

Safety Hazard!

Failure to follow instructions below could result in death or serious injury and equipment or property damage.

For continued performance, reliability, and safety, use only accessories and replacement parts approved by the manufacturer. Using parts and accessories not approved by the manufacturer may void the equipment's limited warranty and could lead to risk of fire, equipment malfunctions, and failures. Refer to the manufacturer's instructions and replacement part catalogs provided by your equipment supplier.

⚠ WARNING

Electrical Shock, Fire, or Explosion Hazard!

Failure to follow these instructions could result in serious injury, death, or property damage.

- Ensure proper servicing of the unit.
- Disconnect all electrical power to furnace before servicing.
- Label all wires prior to disconnecting when servicing controls. Reconnect wires correctly.
- Verify proper operation after servicing.

⚠ WARNING

Safety Precautions!

Failure to follow the safety precautions could result in serious injury, death, or property damage.

- Follow instructions according to the controlled procedures to minimize the risk of the presence of flammable gases or vapors while working.
- Do not work in confined spaces. All maintenance staff and others working in the local area must be instructed on the nature of work.
- Check the area with an appropriate refrigerant detector prior to and during work to ensure the technician is aware of potentially toxic or flammable environment.
- Keep dry powder or CO₂ fire extinguisher adjacent to the charging area. Appropriate fire extinguishing equipment must be available and easily accessible if any hot work is conducted on the refrigerating equipment or any associated parts.
- When handling work related to refrigerating system that involves exposing any pipe work, do not use any sources of ignition that may lead to the risk of fire or explosion. All ignition sources should be kept sufficiently far away from the site of installation, repair, or removal and disposal of the unit, during which refrigerant can possibly be released into the surrounding space.
- Prior to beginning work, the area around the equipment must be supervised to confirm there are no flammable hazards or ignition risks. No Smoking signs must be clearly displayed.
- Ensure that the area is in the open or that it is adequately ventilated before opening the system or conducting any hot work. A continuous ventilation must exist during the course of work that safely disperses any released refrigerant and expels it externally.

Fan Belt Adjustment-Belt Drive Units

⚠ WARNING

Rotating Components!

Failure to disconnect power before servicing could result in rotating components cutting and slashing technician which could result in death or serious injury.

Disconnect all electric power, including remote disconnects before servicing. Follow proper lockout/tagout procedures to ensure the power can not be inadvertently energized.

The fan belts must be inspected periodically to assure proper unit operation. Replacement is necessary if the belts appear frayed or worn. Units with dual belts require a

matched set of belts to ensure equal belt length.

When removing or installing the new belts, do not stretch them over the sheaves. Loosen the belts using the belt tension adjustment bolts on the motor mounting base.

Once the new belts are installed, using a Browning or Gates tension gauge (or equivalent), adjust the belt tension as follows:

1. To determine the appropriate belt deflection:
 - a. Measure the center-to-center shaft distance (in inches) between the fan and motor sheaves.
 - b. Divide the distance measured in Step 1a by 64; the resulting value represents the amount of belt deflection that corresponds to the proper belt tension.
2. Set the large O-ring on the belt tension gauge at the deflection value determined in [Step 1b](#).
3. Set the small O-ring at zero on the force scale of the gauge plunger.
4. Place the large end of the gauge at the center of the belt span; then depress the gauge plunger until the large O-ring is even with the top of the next belt or even with a straightedge placed across the fan and motor sheaves.
5. Remove the belt tension gauge. The small O-ring now indicates a number other than zero on the plunger's force scale. This number represents the force (in pounds) required to give the needed deflection.

6. Compare the "force" scale reading (Step 5) with the appropriate "force" value listed in the Belt tension table. If the "force" reading is outside the range, readjust the belt tension.

Note: Actual belt deflection "force" must not exceed the maximum "force" value shown in the Belt tension measurement and deflection ranges table.

7. Recheck the belt tension at least twice during the first 2 to 3 days of operation. Belt tension may decrease until the new belts are "run in".

Figure 17. Belt tension gauge

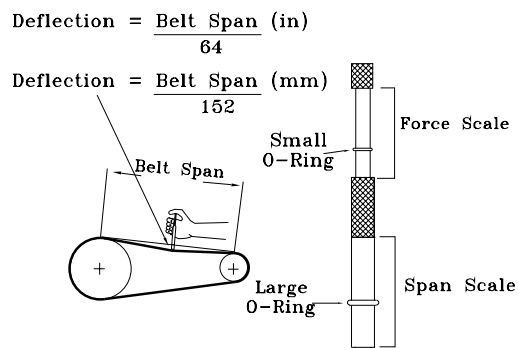

The exhaust gas fan is that lubrication of motor, blower, or fan bearings should not be done, and others should Check the supply fan belts for proper tension and the fan bearings for sufficient lubrication.

Table 17. Belt tension measurement and deflection ranges (in/lb)

Belts Cross Section	Small P.D Range (in)	Deflection Force (lb)					
		Super Gripbelts (in)		Gripnotch (in)		Steel Cable Gripbelts (in)	
		Min.	Max.	Min.	Max.	Min.	Max.
A	3.0–3.6	3.00	4.50	3.87	5.50	3.25	4.00
	3.8–4.8	3.50	5.00	4.50	6.25	3.75	4.75
	5.0–7.0	4.00	5.50	5.00	6.87	4.25	5.25
B	3.4–4.2	4.00	5.50	5.75	8.00	4.50	5.50
	4.4–5.6	5.12	7.12	6.50	9.12	5.75	7.25
	5.8–8.8	6.37	8.75	7.37	10.12	7.00	8.75

Table 18. Belt tension measurement and deflection ranges (mm/kg)

Belts Cross Section	Small P.D Range (mm)	Deflection Force (kg)					
		Super Gripbelts (mm)		Gripnotch (mm)		Steel Cable Gripbelts (mm)	
		Min.	Max.	Min.	Max.	Min.	Max.
A	13.3–16.0	13.3	20.0	17.2	24.5	14.5	17.8
	16.9–21.4	15.6	22.2	20.0	27.8	16.7	21.1
	22.0–31.1	17.8	24.5	22.2	30.6	18.9	23.4
B	15.1–18.7	17.8	24.5	25.6	35.6	20.0	24.5
	19.6–24.9	22.8	31.7	28.9	40.6	25.6	32.3
	25.8–39.1	28.4	38.9	32.8	45.0	31.1	38.9

Monthly Maintenance

Before completing the following checks, turn the unit OFF and lock the main power disconnect switch open.

⚠ WARNING

Hazardous Voltage!

Failure to disconnect power before servicing could result in death or serious injury.

Disconnect all electric power, including remote disconnects before servicing. Follow proper lockout/tagout procedures to ensure the power can not be inadvertently energized. Verify that no power is present with a voltmeter.

Filters

Inspect the return air filters. Clean or replace them if necessary.

Condensate Overflow Switch

During maintenance, the switch float (black ring) must be checked to ensure free movement up and down.

Cooling Season

- Check the unit's drain pans and condensate piping to ensure that there are no blockages.
- Inspect the evaporator and condenser coils for dirt, bent fins, etc. If the coils appear dirty, clean them according to the instructions described in "Coil Cleaning" later in this section.
- Manually rotate the condenser fans to ensure free movement and check motor bearings for wear. Verify that all of the fan mounting hardware is tight.
- Inspect the F/A-R/A damper hinges and pins to ensure that all moving parts are securely mounted. Keep the blades clean as necessary.

⚠ WARNING

Rotating Components!

Failure to disconnect power before servicing could result in rotating components cutting and slashing technician which could result in death or serious injury.

During installation, testing, servicing and troubleshooting of this product it may be necessary to work with live and exposed rotating components. Have a qualified or licensed service individual who has been properly trained in handling exposed rotating components, perform these tasks.

NOTICE

Equipment Damage!

Forcibly turning the motor shaft can damage the gear train and motor beyond repair.

Never turn the motor shaft by hand or with a wrench.

- Verify that all damper linkages move freely; lubricate with white grease, if necessary.
- Check supply fan motor bearings; repair or replace the motor as necessary.
- Check the fan shaft bearings for wear. Replace the bearings as necessary.
- Check the supply fan belt(s). If the belts are frayed or worn, replace them. Refer to the "Fan Belt Adjustment-Belt Drive Units," p. 44 for belt replacement and adjustments.
- Verify that all wire terminal connections are tight.
- Remove any corrosion present on the exterior surfaces of the unit and repaint these areas.
- Generally inspect the unit for unusual conditions (e.g., loose access panels, leaking piping connections, etc.)
- Make sure that all retaining screws are reinstalled in the unit access panels once these checks are complete.
- With the unit running, check and record the following:

- ambient temperature
- compressor oil level (each circuit)
- compressor suction and discharge pressures (each circuit)
- superheat and subcooling (each circuit)

Record this data on an “operator’s maintenance log” like the one shown in Sample maintenance log table in Final Process Section. If the operating pressures indicate a refrigerant shortage, measure the system superheat and system subcooling. For guidelines, refer to “Compressor Start-Up,” p. 37.

Important: *Do not release refrigerant to the atmosphere! If adding or removing refrigerant is required, the service technician must comply with all federal, state and local laws. Refer to general service bulletin MSCU-SB-1 (latest edition).*

Heating Season

The furnace system must be inspected at least once a year by a qualified service personal.

- Inspect the unit’s air filters. If necessary, clean or replace them.
- Check supply fan motor bearings; repair or replace the motor as necessary.
- Inspect both the main unit control panel and heat section control box for loose electrical components and terminal connections, as well as damaged wire insulation. Make any necessary repairs.
- Verify that the electric heat system operates properly.

Coil Cleaning

Regular coil maintenance, including annual cleaning enhances the unit’s operating efficiency by minimizing the following:

- Compressor head pressure and amperage draw
- Evaporator water carryover
- Fan brake horsepower
- Static pressure losses
- Airflow reduction

At least once each year, or more often if the unit is located in a “dirty” environment, clean the condenser coils using the instructions outlined below. Be sure to follow these instructions as closely as possible to avoid damaging the coils.

Table 19. Unit data log

Complete Unit Model Number	
Unit Serial Number	
Wiring Diagram Numbers (from unit control panel)	

⚠ WARNING

Hazardous Chemicals!

Failure to follow this safety precaution could result in death or serious injury. Coil cleaning agents can be either acidic or highly alkaline and can burn severely if contact with skin or eyes occurs.

Handle chemical carefully and avoid contact with skin. ALWAYS wear Personal Protective Equipment (PPE) including goggles or face shield, chemical resistant gloves, boots, apron or suit as required. For personal safety refer to the cleaning agent manufacturer’s Materials Safety Data Sheet and follow all recommended safe handling practices.

Microchannel (MCHE) Coils

NOTICE

Coil Damage!

Failure to follow instructions below could result in coil damage.

DO NOT use any detergents with microchannel condenser coils.

Use pressurized water or air ONLY, with pressure no greater than 600psi.

For additional information regarding the proper microchannel coil cleaning procedure, refer to RT-SVB83*-EN

Due to the soft material and thin walls of the MCHE coils, the traditional field maintenance method recommended for Round Tube Plate Fin (RTPF) coils does not apply to microchannel coils. Moreover, chemical cleaners are a risk factor to MCHE due to the material of the coil. The manufacturer does not recommend the use of chemical cleaners to clean microchannel coils. Using chemical cleaners could lead to warranty claims being further evaluated for validity and failure analysis.

The recommended cleaning method for microchannel condenser coils is pressurized water or air with a non-pinpoint nozzle and an ECU of at least 180 with pressure no greater than 600 psi. To minimize the risk of coil damage, approach the cleaning of the coil with the pressure washer aimed perpendicular to the face of the coil during cleaning. Optimum clearance between the sprayer nozzle and the microchannel coil is 1-inch to 3-inch.

Final Process

For future reference, record the unit data below in the blanks provided.

Maintenance

Table 19. Unit data log (continued)

-schematic(s)	
-connections	
Network ID	

Table 20. Sample maintenance log

Date	Current Ambient Temp F/C	Refrigerant Circuit #1					Refrigerant Circuit #2					
		Compr. Oil Level	Suct. Press. Psig/kPa	Disch. Press Psig/ kPa	Superheat F/C	Sub-cool F/ C	Compr. Oil Level	Suct. Press. Psig/kPa	Disch. Press Psig/ kPa	Superheat F/C	Sub-cool F/ C	
		-ok -low					-ok -low					
		-ok -low					-ok -low					
		-ok -low					-ok -low					
		-ok -low					-ok -low					
		-ok -low					-ok -low					
		-ok -low					-ok -low					
		-ok -low					-ok -low					
		-ok -low					-ok -low					
		-ok -low					-ok -low					
		-ok -low					-ok -low					
		-ok -low					-ok -low					
		-ok -low					-ok -low					
		-ok -low					-ok -low					
		-ok -low					-ok -low					
		-ok -low					-ok -low					

Variable Frequency Drive (VFD)

If installed in an appropriate environment, the VFD requires very little maintenance.

Important: Do not perform wiring, inspection, or repair operations while the power is on. Before starting work, be sure to switch off the power of all machines. After the power is switched off, there is residual voltage in the capacitor inside the inverter. It is necessary to confirm that the main circuit voltage has dropped to a safe level, and to wait for 5 minutes before performing related operations to avoid personal accidents.

Replacing the Cooling Fan

When replacing the cooling fan, use the original fan. To purchase the original fan, contact the agent where you purchased the product or the sales department of our company. There are several models equipped with multiple cooling fans in the inverter.

In order to maximize the service life of the product, all fans must be replaced at the same time. Replacement of other components require very strict maintenance technology and product familiarity, and must undergo strict testing before use after replacement.

It is not recommended that users replace other internal components by themselves. For replacement, contact the agent where you purchased the product or the sales department of our company.

Reforming the Capacitors

The drive DC link capacitors must be reformed (re-aged) if the drive is non-operational for more than one year.

Without reforming, capacitors may get damaged when the drive starts to operate. In order to prevent the capacitors from deteriorating, please energize them for at least 1 hour per year.

If there is no power for more than two years, use the adjustable power supply to gradually increase the voltage from 0V to the rated voltage of the inverter within 2 minutes to 3 minutes, and then activate the main circuit electrolytic capacitor (no-load power on for more than 1 hour).

During subsequent operation, perform normal wiring and confirm that there is no abnormality of the inverter, overcurrent, motor vibration, or speed change.

Replacing a Fuse

When replacing a fuse, use the original fuse. See the following table for the parameters of a fuse.

Fuses must be strictly tested before use after replacement. It is not recommended that users replace fuses by themselves. Contact the agent where you purchased the product or the sales department of our company to purchase the original fuse or for replacement.

Table 21. Relevant parameters of fuse

Voltage	Diameter	Length	Rated Working Voltage	Rated Working Current
208/230V	38mm	10.3mm	500VDC	30A
460V	38mm	10.3mm	500VDC	30A+2A

Figure 18. Fuse



Troubleshooting

⚠ WARNING

Hazardous Service Procedures!

Failure to follow all precautions in this manual and on the tags, stickers, and labels could result in death or serious injury.

Technicians, in order to protect themselves from potential electrical, mechanical, and chemical hazards, **MUST** follow precautions in this manual and on the tags, stickers, and labels, as well as the following instructions: Unless specified otherwise, disconnect all electrical power including remote disconnect and discharge all energy storing devices such as capacitors before servicing. Follow proper lockout/tagout procedures to ensure the power can not be inadvertently energized. When necessary to work with live electrical components, have a qualified licensed electrician or other individual who has been trained in handling live electrical components perform these tasks.

Standard Troubleshooting

Ignition Module

The Ignition Module (IGN) has the ability to provide the service personnel with some unit diagnostics and system status information.

Before turning the main power disconnect switch “Off”, follow the steps below to check the IGN.

To prevent injury or death from electrocution, it is the responsibility of the technician to recognize this hazard and use extreme care when performing service procedures with the electrical power energized.

1. Verify LED on face of the phase monitor is green. If LED is red, correct supply power fault.
2. Verify that the LED on the IGN is burning continuously. If the LED is lit, go to Step 5.
3. Verify that the Digital Display on the mainboard is displaying “-”. If the Digital Display is right, go to Step 5.
4. If the LED is not lit, verify that 24 Vac is present between R and C. If the LED is not lit and 24 Vac is present replace the IGN. If the Digital Display is not lit and 24 Vac is present replace the mainboard. If 24 Vac is not present, check fuse 2 on the mainboard and check transformer (TNS1). Proceed to Step 5 if necessary.
5. If no failures are indicated, use the TEST mode procedures described in the “Unit Start-Up” section or thermostat to start the unit. This procedure will allow you to check all of the external controls (relays, contactors, etc) and the IGN.
6. Test the system through all of the available modes, and

verify operation of all outputs, controls, and modes.

Refer to the sequence of operations for each mode, to assist in verifying proper operation. Make the necessary repairs and proceed to Step 6 and Step 7.

7. If no abnormal operating conditions appear in the test mode, exit the test mode by turning the power “Off” at the main power disconnect switch and removing the test mode connections.

Failures

Heating Failure

Verify Heat Failure by Ignition Module (IGN) LED indicator:

Flash	Description
Slow Flash	Normal, call for Heat
2 Flashes	System lockout; failed to detect or sustain flame
3 Flashes	Pressure switch problem detected
4 Flashes	High limit switch protection device open
5 Flashes	Flame sensed and gas valve not energized or flame sensed and no “W” signal
6 Flashes	Flame rollout switch open
7 Flashes	Thermostat miswired (W1 and W2 swapped)

Simultaneous Heat and Cool Failure

Emergency Stop is activated.

To Clear an Alarm

Once the alarm has been identified and the cause has been removed (for example, replaced faulty sensor), the alarm can be cleared from the display.

Resetting Cooling and Heating Lockouts

Cooling Failures and Heating Lockouts are reset in an identical manner.

Method 1 section explains resetting the system from the space; Method 2 section explains resetting the system at the unit.

Note: Before resetting Cooling Failures and Heating Lockouts, check the Failure Status Diagnostics by the methods previously explained. Diagnostics will be lost when the power to the unit is disconnected.

Troubleshooting

Method 1

To reset the system from the space, turn the “Mode” selection switch at the thermostat to the “Off” position. After approximately 30 seconds, turn the “Mode” selection switch to the desired mode, i.e. Heat, Cool, or Auto.

Method 2

To reset the system at the unit, cycle the unit power by turning the disconnect switch “Off” and then “On”.

Table 22. Troubleshooting chart

SYMPTOM	POSSIBLE CAUSE	REMEDY
Unit will not run	Power off or loose electrical connection	Check for correct voltage at compressor contactor in control box
	Thermostat out of calibration-set too high	Reset
	Failed contactor	Check for 24 volts at contactor coil - replace if contacts are open
	Blown fuses	Replace fuses
	Transformer defective	Check wiring - replace transformer
	Interconnecting low voltage wiring damaged	Replace thermostat wiring
Condenser fan runs, compressor doesn't	Compressor damaged	Replace
	Loose connection	Check for correct voltage at compressor - check and tighten all connection.
	Compressor stuck, grounded or open motor winding open internal overload	Wait at least 2 hours for overload to reset. If still open, replace the compressor.
	Low voltage condition	Determine cause and correct. At compressor terminals, voltages must be within 10% of rating plate volts when unit is operating.
Insufficient cooling	Improperly sized unit	Recalculate load
	Improper airflow	Check - should be approximately 400 CFM per ton.
	Incorrect refrigerant charge	Charge per procedure attached to unit service panel.
	Air, non-condensable or moisture in system	Recover refrigerant, evacuate and recharge, add filter drier
	Incorrect voltage	Determine cause and correct. At compressor terminals, voltages must be within 10% of rating plate volts when unit is operating.
Compressor short cycles	Incorrect voltage	At compressor terminals, voltage must be $\pm 10\%$ or nameplate marking when unit is operating.
	Defective overload protector	Replace - check for correct voltage
	Refrigerant undercharge	Add refrigerant
Compressor operates continuously	Dirty air filter	Replace filter
	Unit undersized for load	Decrease load or increase unit size
	Thermostat temperature set too low	Reset thermostat
	Low refrigerant charge	Locate leak, repair, and recharge
	Air in system	Recover refrigerant, evacuate system, and recharge
	Outdoor coil dirty or restricted	Clean coil or remove restriction
Registers sweat	Low evaporator airflow	Increase speed of blower or reduce restriction - replace air filter

Table 22. Troubleshooting chart (continued)

SYMPTOM	POSSIBLE CAUSE	REMEDY
High head-low vapor pressure	Restriction in liquid line, expansion device or filter drier	Remove or replace defective component
	Flow check piston size too small	Change to correct size piston
	Incorrect capillary tubes	Change coil assembly
	EXV does not open	Check the control wiring and valve body; replace the coil or the valve body
High head-high or normal vapor pressure - Cooling mode	Dirty condenser coil	Clean coil
	Refrigerant overcharge	Correct system charge
	Condenser fan not running	Repair or replace
	Air or non-condensable in system	Recover refrigerant, evacuate and recharge
Low head-high vapor pressures	Defective compressor valves	Replace compressor
	Incorrect capillary tubes	Replace coil assembly
Low vapor - cool compressor - iced evaporator coil	Low evaporator airflow	Increase speed of blower or reduce restriction - replace air filter
	Operating below 65°F outdoors	Add Low Ambient Kit
	Moisture in system	Recover refrigerant - evacuate & recharge - add filter drier
High vapor pressure	Excessive load	Recheck load calculation
	Defective compressor	Replace
Fluctuating head and vapor pressure	Air or non-condensable in system	Recover refrigerant - evacuate and recharge.
Gurgle or pulsing noise at expansion device or liquid line	Air or non-condensable in system	Recover refrigerant - evacuate and recharge.
Circulating air blower and inducer run continuously, compressor will not start	Manual reset overtemperature control tripped	Reset or replace.
	Wire loose in limit circuit	Check wiring.
Burners will not ignite	Water in gas line	Drain. Install drip leg.
	No power to furnace	Check power supply fuses, wiring or circuit breaker.
	No 24 volts power supply to control circuit	Check transformer.
	Miswired or loose connections	Check all wiring and wire nut connections.
	Misaligned spark electrodes	Check flame ignition and sense electrode positioning. Adjust as necessary.
	No gas at main burners	Check gas line for air. Purge as necessary. NOTE: After purging gas line of air, wait at least 5 minutes for any gas to dissipate before attempting to light unit. Check gas valve.
Inadequate heating	Dirty air filter	Clean or replace filter as necessary; check power supply fuses, wiring, or circuit breaker.
	Gas input to furnace too low	Check gas pressure at manifold with that on unit nameplate.
	Unit undersized for application	Replace with proper unit or add additional unit.
	Restricted airflow	Clean or replace filter, remove any restriction
	Limit switch cycles main burners	Check rotation of blower, temperature rise of unit. Adjust as necessary.

Troubleshooting

Table 22. Troubleshooting chart (continued)

SYMPTOM	POSSIBLE CAUSE	REMEDY
Poor flame characteristics	Incomplete combustion results in: Aldehyde odors, carbon monoxide, sooting flame, floating flame	Tighten all screws around burner compartment
		Cracked heat exchanger. Replace as necessary.
		Unit over-fired. Reduce input (change orifices or adjust gas line or manifold pressure).
		Check burner alignment
		Inspect heat exchanger for blockage. Clean as necessary.
Both condenser fan and compressor start-up and shutdown frequently (about three minutes per cycle)	Abnormal high discharge pressure caused the high pressure switch act	Reference to the remedy of 'High head-high or normal vapor pressure-cooling mode'.

Wiring Diagrams

Note: Contact technical support for wiring diagrams.

Table 23. Wiring diagrams

Type of Airflow	Schematic Type	Voltage	Description
Multi-Speed Fans	Power and Control	208/230	GDK090-150, 60Hz, 2-Stage GasHeat w/VFD
Multi-Speed Fans	Power and Control	460	GDK090-150, 60Hz, 2-Stage GasHeat w/VFD

Warranty

For Commercial Unitary Equipment Rated 25 Tons and Under and Related Accessories

Products Covered — This warranty is extended by Trane, and applies to the following products:

- All packaged and split system air conditioners and heat pumps have a rated capacity of 25 tons and under.
- All packaged combinations gas/electric air conditioners having a rated capacity of 25 tons and under.
- All packaged combination gas/electric air conditioners having a rated capacity of 1.5 through 5 tons single phase electric power and used for commercial applications. (As used in this warranty, a commercial application is any application where the end purchaser uses the product for other than personal, family or household purposes.)
- All accessories for the above products which are sold by Trane and applied in accordance with Trane specifications.

Basic Warranty

The warrantor warrants for a period of twelve (12) months from the initial start-up or eighteen (18) months from date of shipment, whichever is sooner, that the products covered by this warranty (1) are free from defects in material and manufacture, and (2) have the capacities and ratings set forth in the warrantor's catalogs and bulletins. If any part of your air conditioner fails because of a manufacturing defect, Warrantor will furnish without charge the required replacement part.

If the heat exchanger fails because of a manufacturing defect within five years from the date of start-up, Warrantor will furnish without charge a replacement heat exchanger. In addition, if the optional, factory installed, stainless steel heat exchanger fails because of a manufacturing defect within ten years from the date of start-up, Warrantor will furnish without charge a replacement heat exchanger.

Any local transportation, related service labor and diagnosis calls are not included. In addition, if the sealed motor-compressor fails because of a manufacturing defect within the second through fifth year from the date of original purchase, Warrantor will furnish without charge the required replacement compressor.

Exclusions and Limitations

The warrantor's obligations and liabilities under this warranty are limited to furnishing F.O.B. factory or

warehouse at the warrantor-designated shipping point, freight allowed to Buyer's city (or port of export for shipments outside the conterminous United States) a replacement product or, at the option of the warrantor, parts for the repair of the product not conforming to this warranty and which have been returned to the warrantor.

The warrantor's warranty is conditional on the Customer providing written notice to the warrantor within thirty (30) days of the discovery of the defect. No product shall be returned to the warrantor without the warrantor's written permission. No liability whatever shall attach to warrantor until said products have been fully paid for and then said liability shall be limited to the purchase price of the equipment shown to be defective.

The warranty does not apply to any compressor or gas-fired heat exchanger which has been repaired or altered in such manner as, in the judgement of the warrantor, affects its stability or reliability. This warranty does not cover (1) any heat exchanger which has been fired with an improper type of fuel (2) a heat exchanger which is installed in a beauty parlor, dry cleaning establishment, de-greasing plant or in any corrosive atmosphere; or (3) any heat exchanger which is not shown to be defective by the warrantor's inspection.

This warranty does not cover damage due to accident, abuse, improper use, external causes, freezing, corrosion, erosion or deterioration. Local transportation, related service labor, air filters, diagnosis calls, refrigerant and related items are not covered.

THE WARRANTY AND LIABILITY SET FORTH HEREIN ARE IN LIEU OF ALL OTHER WARRANTIES AND LIABILITIES, WHETHER IN CONTRACT OR IN NEGLIGENCE, EXPRESS OR IMPLIED, IN LAW OR IN FACT, INCLUDING IMPLIED WARRANTIES OR MERCHANTABILITY AND FITNESS FOR A PARTICULAR PURPOSE AND ANY IMPLIED WARRANTIES OTHERWISE ARISING FROM THE COURSE OF DEALING OR TRADE. IN NO EVENT SHALL THE WARRANTOR BE LIABLE FOR ANY INCIDENTAL OR CONSEQUENTIAL DAMAGES.

The warrantor makes certain further warranty protection available on an optional, extra-cost basis. Any further warranty must be in writing. If you wish further help or information concerning this warranty, contact: Trane — Warrantor, 2701 Wilma Rudolph Blvd., Clarksville, TN 37040

Trane and American Standard create comfortable, energy efficient indoor environments for commercial and residential applications. For more information, please visit trane.com or americanstandardair.com.

Trane and American Standard have a policy of continuous product and product data improvement and reserve the right to change design and specifications without notice. We are committed to using environmentally conscious print practices.

RT-SVX096A-EN 04 Oct 2024
Supersedes (New)

©2024