



# Installation, Operation, and Maintenance

## Voyager™ 3

Packaged Rooftop Air Conditioners with Symbio™

700 Controls

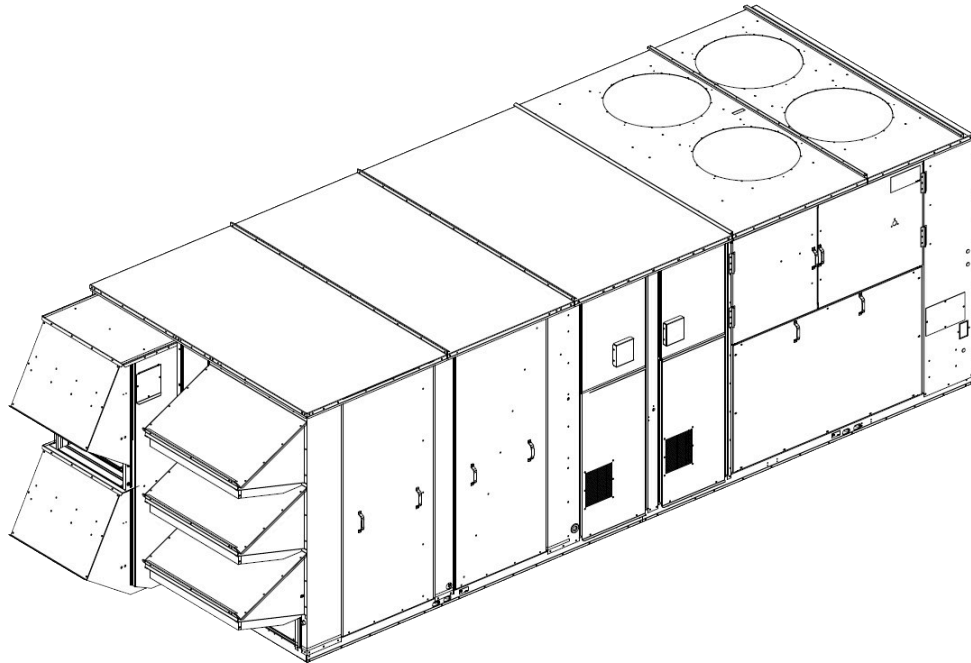
27.5 to 50 Tons - 60 Hz

22.9 to 41.7 Tons (82-142 kW) - 50 Hz

"C" and later design  
sequence

**60Hz/3 phase:** TC\*,  
TE\*, YC\*, 330C, 360C,  
420C, 480C, 600C

**50 Hz/3 phase:** TC\*,  
TE\*, YC\*, 275C, 305C,  
350C, 400C, 500C



### ⚠ SAFETY WARNING

Only qualified personnel should install and service the equipment. The installation, starting up, and servicing of heating, ventilating, and air-conditioning equipment can be hazardous and requires specific knowledge and training. Improperly installed, adjusted or altered equipment by an unqualified person could result in death or serious injury. When working on the equipment, observe all precautions in the literature and on the tags, stickers, and labels that are attached to the equipment.



# Introduction

Read this manual thoroughly before operating or servicing this unit.

## Warnings, Cautions, and Notices

Safety advisories appear throughout this manual as required. Your personal safety and the proper operation of this machine depend upon the strict observance of these precautions.

The three types of advisories are defined as follows:



Indicates a potentially hazardous situation which, if not avoided, could result in death or serious injury.



Indicates a potentially hazardous situation which, if not avoided, could result in minor or moderate injury. It could also be used to alert against unsafe practices.



Indicates a situation that could result in equipment or property-damage only accidents.

## Important Environmental Concerns

Scientific research has shown that certain man-made chemicals can affect the earth's naturally occurring stratospheric ozone layer when released to the atmosphere. In particular, several of the identified chemicals that may affect the ozone layer are refrigerants that contain Chlorine, Fluorine and Carbon (CFCs) and those containing Hydrogen, Chlorine, Fluorine and Carbon (HCFCs). Not all refrigerants containing these compounds have the same potential impact to the environment. Trane advocates the responsible handling of all refrigerants.

## Important Responsible Refrigerant Practices

Trane believes that responsible refrigerant practices are important to the environment, our customers, and the air conditioning industry. All technicians who handle refrigerants must be certified according to local rules. For the USA, the Federal Clean Air Act (Section 608) sets forth the requirements for handling, reclaiming, recovering and recycling of certain refrigerants and the equipment that is used in these service procedures. In addition, some states or municipalities may have additional requirements that must also be adhered to for responsible management of refrigerants. Know the applicable laws and follow them.

### ⚠ WARNING

#### Proper Field Wiring and Grounding Required!

Failure to follow code could result in death or serious injury.

All field wiring **MUST** be performed by qualified personnel. Improperly installed and grounded field wiring poses **FIRE** and **ELECTROCUTION** hazards. To avoid these hazards, you **MUST** follow requirements for field wiring installation and grounding as described in **NEC** and your local/state/national electrical codes.

### ⚠ WARNING

#### Personal Protective Equipment (PPE) Required!

Failure to wear proper PPE for the job being undertaken could result in death or serious injury.

Technicians, in order to protect themselves from potential electrical, mechanical, and chemical hazards, **MUST** follow precautions in this manual and on the tags, stickers, and labels, as well as the instructions below:

- **Before installing/servicing this unit, technicians MUST put on all PPE required for the work being undertaken (Examples; cut resistant gloves/sleeves, butyl gloves, safety glasses, hard hat/bump cap, fall protection, electrical PPE and arc flash clothing). ALWAYS refer to appropriate Safety Data Sheets (SDS) and OSHA guidelines for proper PPE.**
- **When working with or around hazardous chemicals, ALWAYS refer to the appropriate SDS and OSHA/GHS (Global Harmonized System of Classification and Labelling of Chemicals) guidelines for information on allowable personal exposure levels, proper respiratory protection and handling instructions.**
- **If there is a risk of energized electrical contact, arc, or flash, technicians MUST put on all PPE in accordance with OSHA, NFPA 70E, or other country-specific requirements for arc flash protection, PRIOR to servicing the unit. NEVER PERFORM ANY SWITCHING, DISCONNECTING, OR VOLTAGE TESTING WITHOUT PROPER ELECTRICAL PPE AND ARC FLASH CLOTHING. ENSURE ELECTRICAL METERS AND EQUIPMENT ARE PROPERLY RATED FOR INTENDED VOLTAGE.**

**⚠ WARNING****Follow EHS Policies!**

Failure to follow instructions below could result in death or serious injury.

- All Trane personnel must follow the company's Environmental, Health and Safety (EHS) policies when performing work such as hot work, electrical, fall protection, lockout/tagout, refrigerant handling, etc. Where local regulations are more stringent than these policies, those regulations supersede these policies.
- Non-Trane personnel should always follow local regulations.

**⚠ WARNING****R-454B Flammable A2L Refrigerant!**

Failure to use proper equipment or components as described below could result in equipment failure, and possibly fire, which could result in death, serious injury, or equipment damage.

The equipment described in this manual uses R-454B refrigerant which is flammable (A2L). Use ONLY R-454B rated service equipment and components. For specific handling concerns with R-454B, contact your local representative.

**⚠ WARNING****Electrical Shock Hazard!**

Failure to follow instructions below could result in death or serious injury.

Properly connect the system's oversized protective earthing (grounding) terminal(s).

## Overview of Manual

One copy of the appropriate service literature ships inside the control panel of each unit. The procedures discussed in this manual should only be performed by qualified, experienced HVAC technicians.

**Note:** *Do not release refrigerant to the atmosphere! If adding or removing refrigerant is required, the service technician must comply with all federal, state, and local laws.*

This document describes the proper installation, startup, operation, and maintenance procedures for Voyager 3 units.

By carefully reviewing the information within this manual and following the instructions, the risk of improper operation and/or component damage will be minimized.

It is important that periodic maintenance be performed to help assure trouble free operation. A maintenance schedule is provided at the end of this manual. Should equipment failure occur, contact a qualified service organization with qualified, experienced HVAC technicians to properly diagnose and repair this equipment.

## Copyright

This document and the information in it are the property of Trane, and may not be used or reproduced in whole or in part without written permission. Trane reserves the right to revise this publication at any time, and to make changes to its content without obligation to notify any person of such revision or change.

## Trademarks

All trademarks referenced in this document are the trademarks of their respective owners.

## Factory Training

Factory training is available through Trane University™ to help you learn more about the operation and maintenance of your equipment. To learn about available training opportunities, contact Trane University™.

**Online:** [www.trane.com/traneuniversity](http://www.trane.com/traneuniversity)

**Email:** [traneuniversity@trane.com](mailto:traneuniversity@trane.com)

## Revision History

Updates to:

- A2L chapter
- Model Number Description
- Approximate operating weights-optional components-lbs./kg table
- Component static pressure drops tables
- Operating pressure figures
- Maintenance - Refrigerant Coils section
- Compressor restrictor location



# Table of Contents

Model Number Description .....	7	Electrical Requirements .....	28
60 Hz Description .....	7	Field Installed Control Wiring .....	28
50 Hz Description .....	9	Gas Heat Requirements .....	28
General Information .....	11	Installation General Requirements .....	29
About the Unit .....	11	Condensate Drain Connection .....	29
Unit Inspection .....	11	Condensate Overflow Switch .....	29
Exterior Inspection .....	11	O/A Sensor and Tubing Installation .....	29
Inspection for Concealed Damage .....	11	Units with Statitrac™ .....	30
Repair .....	11	Installation Electrical .....	32
Storage .....	11	Disconnect Switch External Handle (Factory Mounted Option) .....	32
Unit Dimensions and Weights .....	12	Main Power Wiring .....	32
Recommended Clearances .....	12	Through-the-Base Electrical (Optional Accessory) .....	34
Roof Curb and Ductwork .....	12	Electrical Wire Sizing and Protection Device Equations .....	34
Horizontal Ductwork .....	12	Set 1. Cooling Only Rooftop Units and Cooling with Gas Heat Rooftop Units .....	34
Unit Dimensions .....	13	Set 2. Rooftop Units with Electric Heat .....	34
Unit Rigging and Placement .....	19	Low Voltage Wiring .....	35
A2L Information and Installation Requirements .....	23	Control Power Transformer .....	35
Installation/Code Compliance Requirements .....	23	Field Installed AC Control Wiring .....	35
A2L Work Procedures .....	23	Field Installed DC Control Wiring .....	36
Servicing .....	23	LonTalk Communication Interface (Optional) .....	36
Leak Detection .....	24	BACnet Communications Interface (Optional) .....	36
Refrigerant Removal and Evacuation .....	24	System Input Devices and Functions .....	36
Refrigerant Charging .....	25	Supply Fan Failure .....	37
Decommissioning .....	25	Clogged Filter Switch (Optional) .....	37
A2L Application Considerations .....	25	Condensate Drain Pan Overflow Switch .....	37
Ignition Sources in Ductwork .....	26	Compressor Disable (CPR1/2/3) .....	37
Ignition Sources in Unit .....	26	High Pressure Control .....	37
Minimum Room Area Limits (Refrigerant charge greater than 3.91 lb per circuit) .....	26	Leak Detection Sensor .....	37
Leak Detection System (Refrigerant charge greater than 3.91 lb per circuit) .....	27	Zone Sensors .....	37
Pre-Installation .....	28	Wall Mounted Relative Humidity Sensor (BAYSENS036*) .....	37
General Unit Requirements .....	28		
Downflow/Upflow Models .....	28		
All Units .....	28		

Duct Mounted Relative Humidity Sensor (BAYSENS037*)	38	Exhaust Fan Operation	56
Integrated Comfort System (BAYSENS073*)	38	Economizer Damper Adjustment	59
Integrated Comfort System (BAYSENS074*)	38	Economizer (O/A) Dampers Models with Ultra-Low Leak Economizers	62
Remote Zone Sensor (BAYSENS016*)	38	Manual Outside Air Damper	66
Remote Zone Sensor (BAYSENS077*)	38	Starting the Compressor	66
Thermostat	38	Starting 27.5-50 Tons Standard and High Efficiency Units	67
High Temperature Sensor (FIAHTST001*)	38	Line Weights	67
Digital Display Zone Sensor (BAYSENS135*)	38	Compressor Oil	67
Touch Screen Programmable Zone Sensor (BAYSENS800)	38	Scroll Compressor Operational Noises	78
Air-Fi Wireless Communication and Sensors (BAYWCII00*, BAYWCII202*, BAYSENS202*, BAYSENS203*, BAYSENS212*, BAYSENS213*, BAYSENS230*, BAYSENS154*, BAYCO2K200*)	38	Compressor Crankcase Heaters	78
Evaporator Frost Control	38	Charging by Subcooling	78
Discharge Line Temp Switch (DLTS)	38	Measuring Subcooling	78
Phase Monitor	39	Gas Heat Units	78
Installation Piping	40	Electric Heat Units	79
General Requirements	40	Final Unit Checkout	79
Connecting the Gas Supply Line to the Furnace Gas Train	40	For All Units	79
Startup	44	For Single Zone Variable Air Volume Units	79
Symbio Service and Installation Mobile App	44	Sequence of Operation	81
Symbio Controls	44	Maintenance	82
Hot Gas Reheat	45	Fan Belt Adjustment	82
Final System Setup	45	Monthly Maintenance	85
Preparing the Unit for Operation	45	Filters	85
Electrical Phasing	46	Condensate Overflow Switch	85
Voltage Supply and Voltage Imbalance	46	Cooling Season	85
Starting the Unit	46	Heating Season	86
Verifying Proper Fan Rotation	50	Coil Cleaning	86
Verifying Proper Air Flow (CFM)	50	Refrigerant Coils	87
		Microchannel Condenser Coil Repair and Replacement	87
		Final Process	87
		Fall Restraint	88
		Refrigeration System	89
		Refrigerant Evacuation and Charging	89
		Charge Storage	89
		Compressor Oil	89
		Compressor Replacements	90
		Electrical Phasing	90



## Table of Contents

---

Precision Suction Restrictor .....	90	Unit Wiring Diagram Numbers .....	99
VFD Programming Parameters (Supply) .....	90	Warranty and Liability Clause .....	100
Diagnostics .....	94	COMMERCIAL EQUIPMENT - 20 TONS AND LARGER AND RELATED ACCESSORIES .....	100
Troubleshooting .....	95		



# Model Number Description

## 60 Hz Description

### Digit 1, 2 — Unit Function

TC = DX Cooling, No Heat  
TE = DX Cooling, Electric Heat  
YC = DX Cooling, Natural Gas Heat

### Digit 3 — Unit Airflow Design

D = Downflow Supply and Upflow Return  
H = Horizontal Supply and Horizontal Return  
F = Horizontal Supply and Upflow Return  
R = Downflow Supply and Horizontal Return

### Digit 4, 5, 6 — Nominal Cooling Capacity

330 = 27.5 Tons  
360 = 30 Tons  
420 = 35 Tons  
480 = 40 Tons  
600 = 50 Tons

### Digit 7 — Major Development Sequence

D = R-454B Refrigerant + Symbio 700

### Digit 8 — Power Supply<sup>1</sup>

E = 208/60/3  
F = 230/60/3  
4 = 460/60/3  
5 = 575/60/3

### Digit 9 — Heating Capacity<sup>2</sup>

0 = No Heat (TC Only)  
L = Low Heat (YC Only)  
H = High Heat (YC Only)  
J = Low Heat-Stainless Steel Gas Heat Exchanger (YC Only)  
K = High Heat-Stainless Steel Gas Heat Exchangers (YC Only)  
M = Low Heat-Stainless Steel Gas Heat Exchanger w/ Modulating Control (27.5-35 Tons YC only)  
P = High Heat-Stainless Steel Gas Heat Exchangers w/ Modulating Control (27.5-35 Tons YC Only)  
R = Low Heat-Stainless Steel Gas Heat Exchanger w/ Modulating Control (40-50 Tons YC Only)  
T = High Heat-Stainless Steel Gas Heat Exchangers w/ Modulating Control (40-50 Tons YC Only)

*Note: When second digit is "E" for Electric Heat, the following values apply in the ninth digit.*

A = 36 kW (27 kW for 208V)  
B = 54 kW (41 kW for 208V)  
C = 72 kW  
D = 90 kW  
E = 108 kW

### Digit 10 — Design Sequence

\* = Current

*Note: Sequence may be any letter A through Z, or any digit 1 through 9.*

### Digit 11 — Exhaust<sup>4</sup>

0 = None  
1 = Barometric Relief (Available w/ Economizer only)  
2 = 100% Power Exhaust Fan (Available w/ Economizer Only)  
3 = 50% Power Exhaust Fan (Available w/ Economizer Only)  
4 = 100% Fresh Air Tracking Power Exhaust Fan (Available w/ Economizer Only)  
5 = 50% Fresh Air Tracking Power Exhaust Fan (Available w/ Economizer Only)  
6 = 100% Power Exhaust w/ Statitrac™  
7 = 100% Power Exhaust Fan w/ Ultra Low Leak Exhaust Damper (Available w/ Economizer Only)  
8 = 50% Power Exhaust Fan w/ Ultra Low Leak Exhaust Damper (Available w/ Economizer Only)  
9 = 100% Power Exhaust w/ Ultra Low Leak Exhaust Damper w/ Statitrac™

### Digit 12 — Filter

A = 2" MERV 4, Std Eff, Throwaway Filters  
B = 2" MERV 8, High Eff, Throwaway Filters  
C = 4" MERV 8, High Eff, Throwaway Filters  
D = 4" MERV 14, High Eff, Throwaway Filters

### Digit 13 — Supply Fan Motor, HP

1 = 7.5 HP  
2 = 10 HP  
3 = 15 HP  
4 = 20 HP  
9 = 25 HP

### Digit 14 — Supply Air Fan Drive Selections

A = 550 RPM  
B = 600 RPM  
C = 650 RPM  
D = 700 RPM  
E = 750 RPM  
G = 800 RPM  
H = 500 RPM  
J = 525 RPM  
K = 575 RPM  
L = 625 RPM  
M = 675 RPM  
N = 725 RPM  
P = 775 RPM  
Q = 825 RPM  
R = 850 RPM  
S = 900 RPM

### Digit 15 — Outside Air Selection

A = No Outside Air  
B = 0-25% Manual Damper  
C = 0-100% Economizer, Dry Bulb Control  
D = 0-100% Economizer, Reference Enthalpy Control  
E = 0-100% Economizer, Differential Enthalpy Control  
F = "C" Option and Low Leak Fresh Air Damper  
G = "D" Option and Low Leak Fresh Air Damper  
H = "E" Option and Low Leak Fresh Air Damper  
J = "C" Option and Ultra Low Leak Outside Air Damper  
K = "D" Option and Ultra Low Leak Outside Air Damper  
L = "E" Option and Ultra Low Leak Outside Air Damper  
1 = Option "C" with Traq  
2 = Option "D" with Traq  
3 = Option "E" with Traq  
4 = Option "F" with Traq  
5 = Option "G" with Traq  
6 = Option "H" with Traq  
7 = Option "C" with Traq w/ Ultra Low Leak Outside Air Damper  
8 = Option "D" with Traq w/ Ultra Low Leak Outside Air Damper  
9 = Option "E" with Traq w/ Ultra Low Leak Outside Air Damper

### Digit 16 — System Control

8 = Multi-speed Fan  
E = Multi-speed Fan w/ Bypass  
F = Multi-speed Fan w/ Motor Shaft Grounding Ring  
G = Multi-speed Fan w/ Bypass & Motor Shaft Grounding Ring  
4 = VAV Supply Air Temperature Control  
5 = VAV Supply Air Temperature Control w/Bypass  
A = VAV Supply Air Temperature Control w/ Motor Shaft Grounding Ring  
B = VAV Supply Air Temperature Control w/ Bypass & Motor Shaft Grounding Ring

6 = Single Zone VAV  
7 = Single Zone VAV w/ Bypass  
C = Single Zone VAV w/ Motor Shaft Grounding Ring  
D = Single Zone VAV w/ Bypass & Motor Shaft Grounding Ring

*Note: Zone sensors are not included with option and must be ordered as a separate accessory.*

*Note: Shaft Grounding ring not available with 25HP motor.*



# Model Number Description

## Miscellaneous Options

### Digit 17

0 = No Service Valves  
A = Service Valves

*Discharge service valves are standard and included in all units.*

### Digit 18

B = Through the Base Electrical Provision

### Digit 19

C = Non-Fused Disconnect Switch w/ External Handle

### Digit 20

D = Factory-Powered 15A GFI Convenience Outlet and Non-Fused Disconnect Switch w/ External Handle

### Digit 21

E = Field-Powered 15A GFI Convenience Outlet

### Digit 22

\* = Unused Digit

### Digit 23

G = Ventilation Override

### Digit 24

H = Hinged Service Access

### Digit 25

H = Condenser Louvered Hail Guards  
J = Condenser Coil Guards (standard)

### Digit 26

0 = None  
K = Advanced Control and LonTalk Comm (LCI)  
B = Advanced Control and BACnet/Modbus Comm (BCI)  
A = Advanced Control and AirFi Wireless (WCI)

### Digit 27

0 = 5kA SCCR  
D = High Fault 65kA SCCR Disconnect<sup>5</sup>  
E = High Fault 65kA SCCR Disconnect w/Powered Convenience Outlet<sup>5</sup>

### Digit 28

0 = Standard Drain Pan  
M = Stainless Steel Drain Pan  
1 = Standard Drain Pan w/ Condensate Overflow Switch  
2 = Stainless Steel Drain Pan w/ Condensate Overflow Switch

### Digit 29 — Efficiency/ Condenser Coil Options

0 = Standard Efficiency Unit (eStage)  
J = Standard Efficiency Unit (eStage) w/ Corrosion Protected Condenser Coil  
K = High Efficiency Unit (eStage)  
L = High Efficiency Unit (eStage) w/ Corrosion Protected Condenser Coil

### Digit 30 — Not used

### Digit 31 — Miscellaneous Options

P = Discharge Temperature Sensor  
R = Clogged Filter Switch

### Digit 32 — Modulating Hot Gas Reheat Option

T = Modulating Hot Gas Reheat

### Digit 33 — Control Expansion Modules

0 = None  
A = Symbio 700 XM- 30 Expansion Module  
B = Symbio 700 XM- 32 Expansion Module  
C = Symbio 700 XM- 30 & XM-32 Expansion Modules  
D = Symbio 700 XM- 30 & XM-30 Expansion Modules  
E = Symbio 700 XM- 32 & XM-32 Expansion Modules

### Model Number Notes

#### Notes:

1. All voltages are across the line starting only.
2. Electric Heat KW ratings are based upon voltage ratings of 208/240/480/ 600 V. For a 240 V heater derated to 208 V, the resulting kW rating decreases from 36 kW to 27 kW, and from 54 kW to 41 kW. Voltage offerings are shown in following table (see Table 22, p. 56 for additional information).
3. The service digit for each model number contains 33 digits; all 33 digits must be referenced.
4. Ventilation override exhaust mode is not available for the exhaust fan with fresh air tracking power exhaust. VOM is available for the exhaust fan without fresh air tracking power exhaust.
5. 575 VAC option is 25kA.

Tons	Elec. Heater Rated Volt.	KW				
		27/36	41/54	72	90	108
27.5 to 35	208	x	x			
	240	x	x			
	480	x	x	x	x	
40 and 50	600		x	x	x	
	208		x			
	240		x			
	480		x	x	x	x
	600		x	x	x	x



## 50 Hz Description

### Digit 1, 2 — Unit Function

**TC** = DX Cooling, No Heat  
**TE** = DX Cooling, Electric Heat

### Digit 3 — Unit Airflow Design

**D** = Downflow Supply and Upflow Return  
**H** = Horizontal Supply and Horizontal Return  
**F** = Horizontal Supply and Upflow Return  
**R** = Downflow Supply and Horizontal Return

### Digit 4, 5, 6 — Nominal Cooling Capacity

**275** = 22.9 Tons (82 kW)  
**305** = 25.4 Tons (89 kW)  
**350** = 29.2 Tons (105 kW)  
**400** = 33.3 Tons (120 kW)  
**500** = 41.7 Tons (148 kW)

### Digit 7 — Major Development Sequence

**D** = R-454B Refrigerant + Symbio 700

### Digit 8 — Power Supply<sup>1</sup>

**C** = 380/50/3  
**D** = 415/50/3

### Digit 9 — Heating Capacity<sup>2</sup>

*Note: When second digit is "E" for Electric Heat, the following values apply in the ninth digit.*

**380V / 415V**

**A** = 23 kW / 27 kW  
**B** = 34 kW / 40 kW  
**C** = 45 kW / 54 kW  
**D** = 56 kW / 67 kW  
**E** = 68 kW / 81 kW

### Digit 10 — Design Sequence

\* = Current

*Note: Sequence may be any letter A through Z, or any digit 1 through 9.*

### Digit 11 — Exhaust<sup>4</sup>

**0** = None  
**1** = Barometric Relief (Available w/ Economizer only)  
**2** = 100% Power Exhaust Fan (Available w/ Economizer Only)  
**3** = 50% Power Exhaust Fan (Available w/ Economizer Only)  
**4** = 100% Fresh Air Tracking Power Exhaust Fan (Available w/ Economizer Only)  
**5** = 50% Fresh Air Tracking Power Exhaust Fan (Available w/ Economizer Only)  
**6** = 100% Power Exhaust w/ Statitrac™  
**7** = 100% Power Exhaust Fan w/ Ultra Low Leak Exhaust Damper (Available w/ Economizer Only)  
**8** = 50% Power Exhaust Fan w/ Ultra Low Leak Exhaust Damper (Available w/ Economizer Only)  
**9** = 100% Power Exhaust w/ Ultra Low Leak Exhaust Damper w/ Statitrac™

### Digit 12 — Filter

**A** = 2" (51mm) MERV 4, Std Eff, Throwaway Filters  
**B** = 2" MERV (51mm) 8, High Eff, Throwaway Filters  
**C** = 4" (102mm) MERV 8, High Eff, Throwaway Filters  
**D** = 4" (102mm) MERV 14, High Eff, Throwaway Filters

### Digit 13 — Supply Fan Motor, HP

**1** = 7.5 HP (5.6 kW)  
**2** = 10 HP (7.5 kW)  
**3** = 15 HP (10 kW)  
**4** = 20 HP (15 kW)

### Digit 14 — Supply Air Fan Drive Selections

**A** = 458 RPM  
**B** = 500 RPM  
**C** = 541 RPM  
**D** = 583 RPM  
**E** = 625 RPM  
**G** = 664 RPM  
**H** = 417 RPM  
**J** = 437 RPM  
**K** = 479 RPM  
**L** = 521 RPM  
**M** = 562 RPM  
**N** = 604 RPM  
**P** = 646 RPM  
**R** = 708 RPM

### Digit 15 — Outside Air Selection

**A** = No Outside Air  
**B** = 0-25% Manual Damper  
**C** = 0-100% Economizer, Dry Bulb Control  
**D** = 0-100% Economizer, Reference Enthalpy Control  
**E** = 0-100% Economizer, Differential Enthalpy Control  
**F** = "C" Option and Low Leak Fresh Air Damper  
**G** = "D" Option and Low Leak Fresh Air Damper  
**H** = "E" Option and Low Leak Fresh Air Damper  
**J** = "C" Option and Ultra Low Leak Outside Air Damper  
**K** = "D" Option and Ultra Low Leak Outside Air Damper  
**L** = "E" Option and Ultra Low Leak Outside Air Damper  
**1** = Option "C" with Traq  
**2** = Option "D" with Traq  
**3** = Option "E" with Traq  
**4** = Option "F" with Traq  
**5** = Option "G" with Traq  
**6** = Option "H" with Traq  
**7** = Option "C" with Traq w/ Ultra Low Leak Outside Air Damper  
**8** = Option "D" with Traq w/ Ultra Low Leak Outside Air Damper  
**9** = Option "E" with Traq w/ Ultra Low Leak Outside Air Damper

### Digit 16 — System Control

**8** = Multi-speed Fan  
**E** = Multi-speed Fan w/ Bypass  
**F** = Multi-speed Fan w/ Motor Shaft Grounding Ring  
**G** = Multi-speed Fan w/ Bypass & Motor Shaft Grounding Ring  
**4** = VAV Supply Air Temperature Control  
**5** = VAV Supply Air Temperature Control w/Bypass  
**A** = VAV Supply Air Temperature Control w/ Motor Shaft Grounding Ring  
**B** = VAV Supply Air Temperature Control w/ Bypass & Motor Shaft Grounding Ring  
**6** = Single Zone VAV  
**7** = Single Zone VAV w/ Bypass  
**C** = Single Zone VAV w/ Motor Shaft Grounding Ring  
**D** = Single Zone VAV w/ Bypass & Motor Shaft Grounding Ring

*Note: Zone sensors are not included with option and must be ordered as a separate accessory.*



## Model Number Description

---

### Miscellaneous Options

#### Digit 17

0 = No Service Valves

A = Service Valves

*Discharge service valves are standard and included in all units.*

#### Digit 18

B = Through the Base Electrical Provision

#### Digit 19

C = Non-Fused Disconnect Switch w/ External Handle

#### Digit 20

\* = Unused Digit

#### Digit 21

\* = Unused Digit

#### Digit 22

\* = Unused Digit

#### Digit 23

G = Ventilation Override

#### Digit 24

H = Hinged Service Access

#### Digit 25

H = Condenser Louvered Hail Guards

J = Condenser Coil Guards (standard)

#### Digit 26

0 = None

K = Advanced Control and LonTalk Comm (LCI)

B = Advanced Control and BACnet/Modbus Comm (BCI)

A = Advanced Control and AirFi Wireless (WCI)

#### Digit 27

0 = 5kA SCCR

D = High Fault 65kA SCCR Disconnect

#### Digit 28

0 = Standard Drain Pan

M = Stainless Steel Drain Pan

1 = Standard Drain Pan w/ Condensate Overflow Switch

2 = Stainless Steel Drain Pan w/ Condensate Overflow Switch

### Digit 29 — Efficiency/ Condenser Coil Options

0 = Standard Efficiency (eStage) Unit

J = Standard Efficiency (eStage) Unit with Corrosion Protected Condenser Coil

K = High Efficiency Unit (eStage)

L = High Efficiency Unit (eStage) with Corrosion Protected Condenser Coil

### Digit 30 — Not used

### Digit 31 — Miscellaneous Options

P = Discharge Temperature Sensor

R = Clogged Filter Switch

### Digit 32

\* = Unused Digit

### Digit 33 — Control Expansion Modules

0 = None

A = Symbio 700 XM- 30 Expansion Module

B = Symbio 700 XM- 32 Expansion Module

C = Symbio 700 XM- 30 & XM-32 Expansion Modules

D = Symbio 700 XM- 30 & XM-30 Expansion Modules

E = Symbio 700 XM- 32 & XM-32 Expansion Modules

### Model Number Notes

#### Notes:

1. All voltages are across the line starting only.
2. Electric Heat KW ratings are based upon voltage ratings of 380/415 V. Heaters A, B, C, D are used with 22.9-29.2 ton (82-105 kW) units only and heaters B, C, D, E are used with 33.3-41.7 ton (120-148 kW) units only.
3. The service digit for each model number contains 33 digits; all 33 digits must be referenced.
4. Ventilation override exhaust mode is not available for the exhaust fan with fresh air tracking power exhaust. VOM is available for the exhaust fan without fresh air tracking power exhaust.



# General Information

## About the Unit

Overall unit dimensional data is illustrated in “Unit Dimensions and Weights,” p. 12. Each package rooftop unit ships fully assembled and charged with the proper refrigerant quantity from the factory. They are controlled by a microelectronic unit control processor. Several solid state modules are grouped to form the “Control System”. The number of modules within any given control system will be dependent upon the options and accessories ordered with the unit. Acronyms are used extensively throughout this manual when referring to the “Control System”.

Basic unit components include:

- Scroll compressors
- One (1) Intertwined Evaporator Coil
- One (1) Supply Fan
- Three (3) to Four (4) Condenser Fans
- Microchannel Condenser Coils
- Filters (type is dependent on option selection)
- Leak detection system

## Unit Inspection

To protect against loss due to damage incurred in transit, perform inspection immediately upon receipt of the unit.

### Exterior Inspection

If the job site inspection reveals damage or material shortages, file a claim with the carrier immediately. Specify the type and extent of the damage on the bill of lading before signing. Notify the appropriate sales representative.

**Important:** Do not proceed with installation of a damaged unit without sales representative’s approval.

- Visually inspect the complete exterior for signs of shipping damages to unit or packing material.
- Verify that the nameplate data matches the sales order and bill of lading.
- Verify that the unit is properly equipped and there are no material shortages.
- Verify that the power supply complies with the unit nameplate specifications.

### Inspection for Concealed Damage

Visually inspect the components for concealed damage as soon as possible after delivery and before it is stored.

Do NOT walk on the sheet metal base pans. Bridging between the unit’s main supports may consist of multiple 2 by 12 boards or sheet metal grating.

## ⚠ WARNING

### No Step Surface!

Failure to follow instruction below could result in death or serious injury.

Do not walk on the sheet metal drain pan. Walking on the drain pan could cause the supporting metal to collapse and result in the operator/technician falling.

If concealed damage is discovered:

- Notify the carrier’s terminal of the damage immediately by phone and by mail.
- Concealed damage must be reported within 15 days.
- Request an immediate, joint inspection of the damage with the carrier and consignee.
- Stop unpacking the unit.
- Do not remove damaged material from receiving location.
- Take photos of the damage, if possible.
- The owner must provide reasonable evidence that the damage did not occur after delivery.

### Repair

Notify the appropriate sales representative before arranging unit installation or repair.

**Important:** Do not repair unit until the damage has been inspected by the carrier’s representative.

### Storage

Store unit in a level and dry location. Use adequate blocking under the base rail. If unit is not level and supported adequately, damage may occur when removing screws and opening doors.

Take precautions to prevent condensate formation inside the unit electrical components and motors when:

- The unit is stored before it is installed; or,
- The unit is set on the roof curb and temporary auxiliary heat is provided in the building.

Isolate all side panel service entrances and base pan openings (e.g., conduit holes, S/A and R/A openings, and flue openings) to minimize ambient air from entering the unit until it is ready for startup.

**Note:** Do not use the unit heater as temporary heat without completing the startup procedures detailed under Startup information.

The manufacturer will not assume responsibility for equipment damage resulting from accumulation of condensate on the unit electrical components.



# Unit Dimensions and Weights

## Recommended Clearances

Adequate clearance around and above each Voyager 3 unit is required to ensure proper operation and to allow sufficient access for servicing.

If the unit installation is higher than the typical curb elevation, a field constructed catwalk around the unit is recommended to provide safe, easy access for maintenance and servicing. [Table 1, p. 20](#) lists the recommended clearances for single and multiple unit installation. These clearances are necessary to assure adequate serviceability, cataloged capacities, and peak operating efficiency.

If the clearances available on the job site appear to be inadequate, review them with your Trane sales representative.

## Roof Curb and Ductwork

The curbs for the 27.5 to 50 Tons commercial rooftop units enclose the entire unit base area. They are referred to as “full perimeter” type curbs.

Step-by-step instructions for the curb assembly and installation with curb dimensions and curb configuration for “A”, “B”, and “C” cabinets ship with each Trane accessory roof curb kit. (See the latest edition of the curb installation guide) Follow the instructions carefully to assure proper fit when the unit is set into place.

The S/A and R/A ductwork adjoining the roof curb must be fabricated and installed by the installing contractor before the unit is set into place. Trane curbs include flanges around the openings to accommodate duct attachment.

Ductwork installation recommendations are included in the instruction booklet that ships with each Trane accessory roof curb kit.

**Note:** *For sound consideration, cut only the holes in the roof deck for the supply and return duct penetration. Do not remove the roof decking from the inside perimeter of the curb.*

### If a Trane curb accessory kit is not used:

- The ductwork can be attached directly to the S/A and R/A openings. Be sure to use a flexible duct connector at the unit.
- For “built-up” curbs supplied by others, gaskets must be installed around the curb perimeter flange, Supply Air opening, and Return Air openings.
- Insulation must be installed on the bottom of the condenser section of the unit.

## Horizontal Ductwork

When attaching the ductwork to a horizontal supply or horizontal return unit, provide a water tight flexible connector at the unit to prevent noise transmission from the unit into the ductwork. Refer to figures beginning on page for the S/A and R/A opening dimensions.

All outdoor ductwork between the unit and the structure should be weather proofed after installation is completed.

If optional power exhaust is selected, an access door must be field-installed on the horizontal return ductwork to provide access to exhaust fan motors.

## Unit Dimensions

Figure 1. 60 Hz 27.5-35, 50 Hz 23-29 Tons (TCD, TED, YCD low heat)

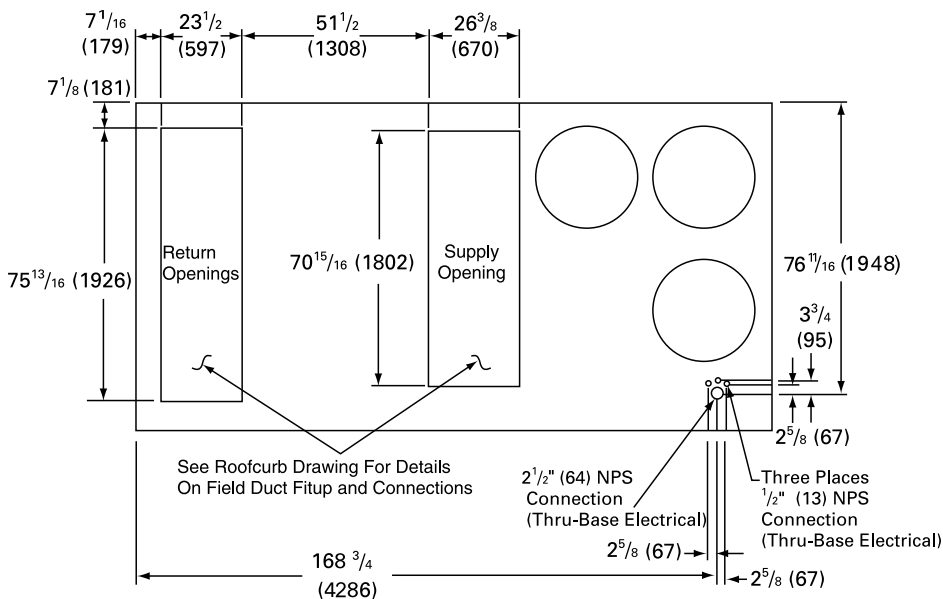
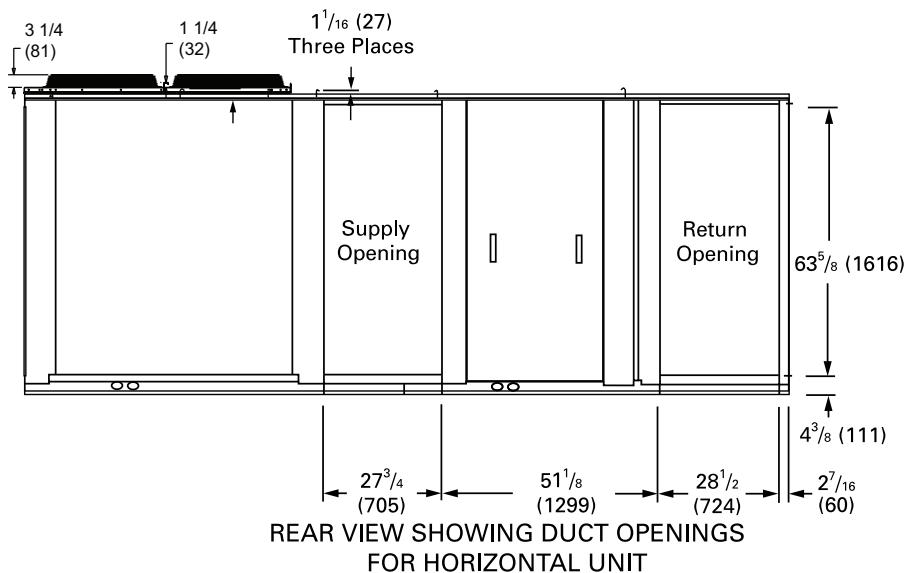


Figure 2. Rear view showing duct openings for horizontal supply and return, 60 Hz 27.5-35, 50Hz 23-29 Tons (TCH, TEH, YCH low heat)



**Notes:**

- On horizontal units, the VFD is located between the supply and return ductwork, which makes access limited.
- For combination of horizontal and downflow openings (digit 3 = F or R) see for appropriate downflow dimensions and for appropriate horizontal dimensions.



## Unit Dimensions and Weights

Figure 3. 60 Hz 27.5-35, 50 Hz 23-29 tons (TC, TE, YC low heat)

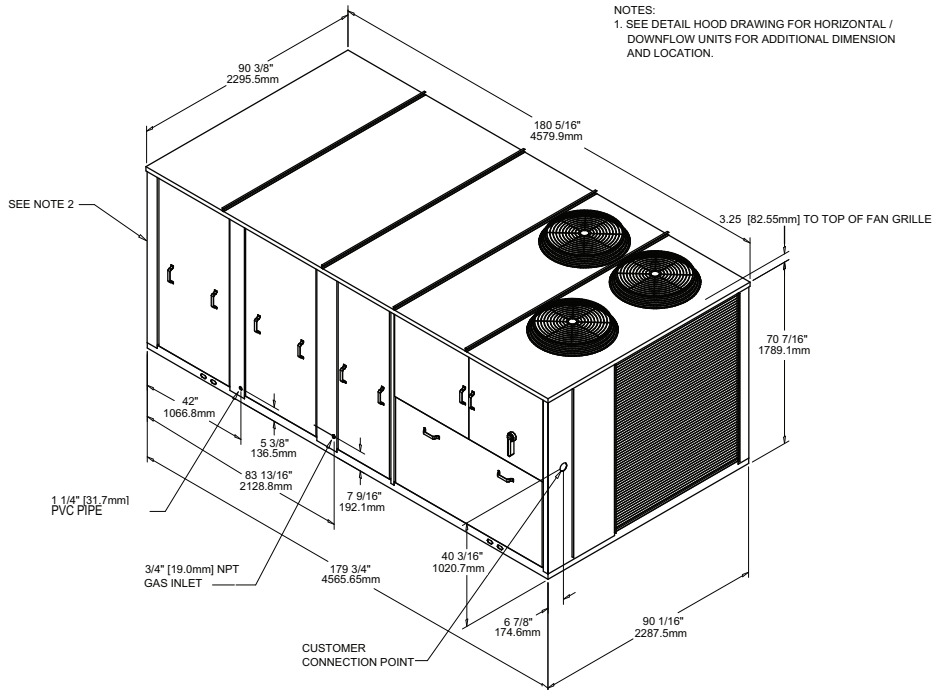
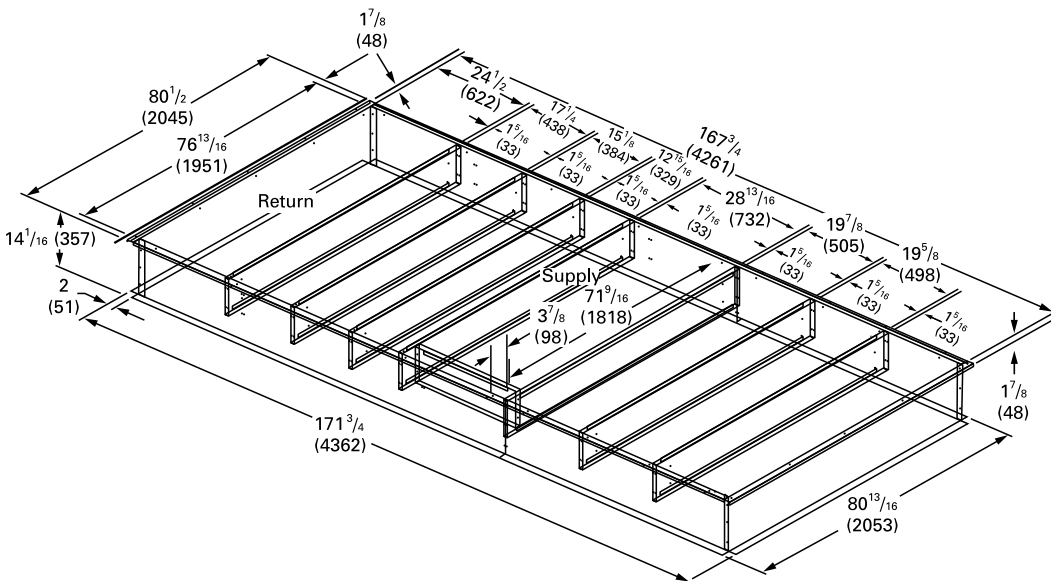


Figure 4. Curb assembly, 60 Hz 27.5-35, 50 Hz 23-29 tons (TC, TE, YC low heat)



Note: Dimensions in ( ) are mm, 1"= 25.4 mm.

Figure 5. 60 Hz 27.5-35 tons (YCD high heat)

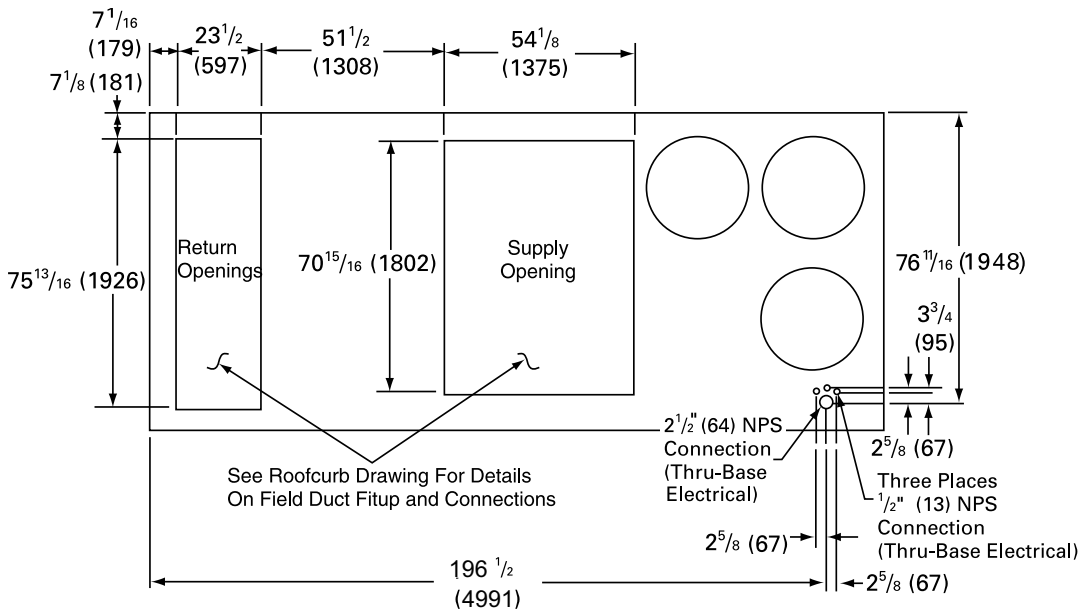
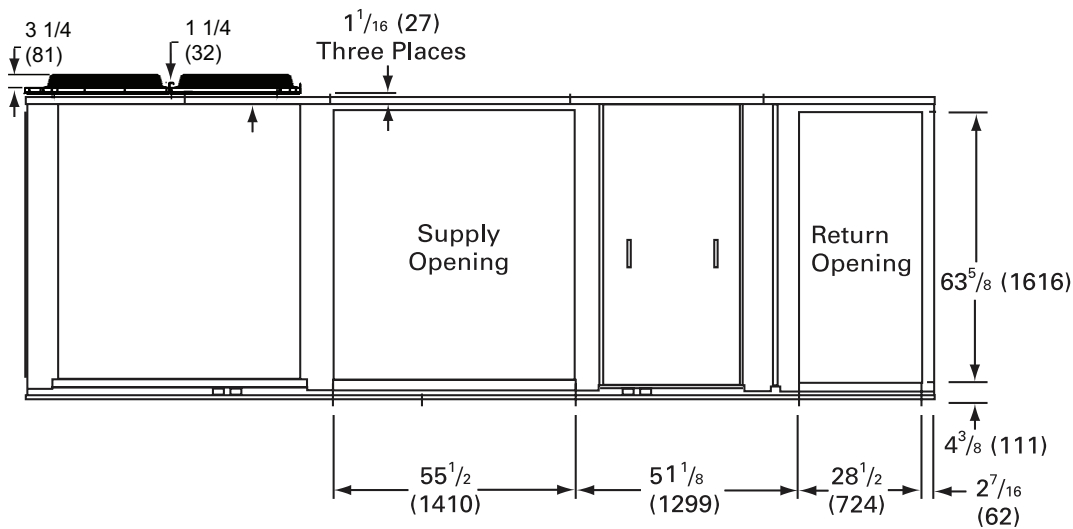


Figure 6. Rear view showing duct openings for horizontal supply and return, 60 Hz 27.5-35 Tons (YCH high heat)

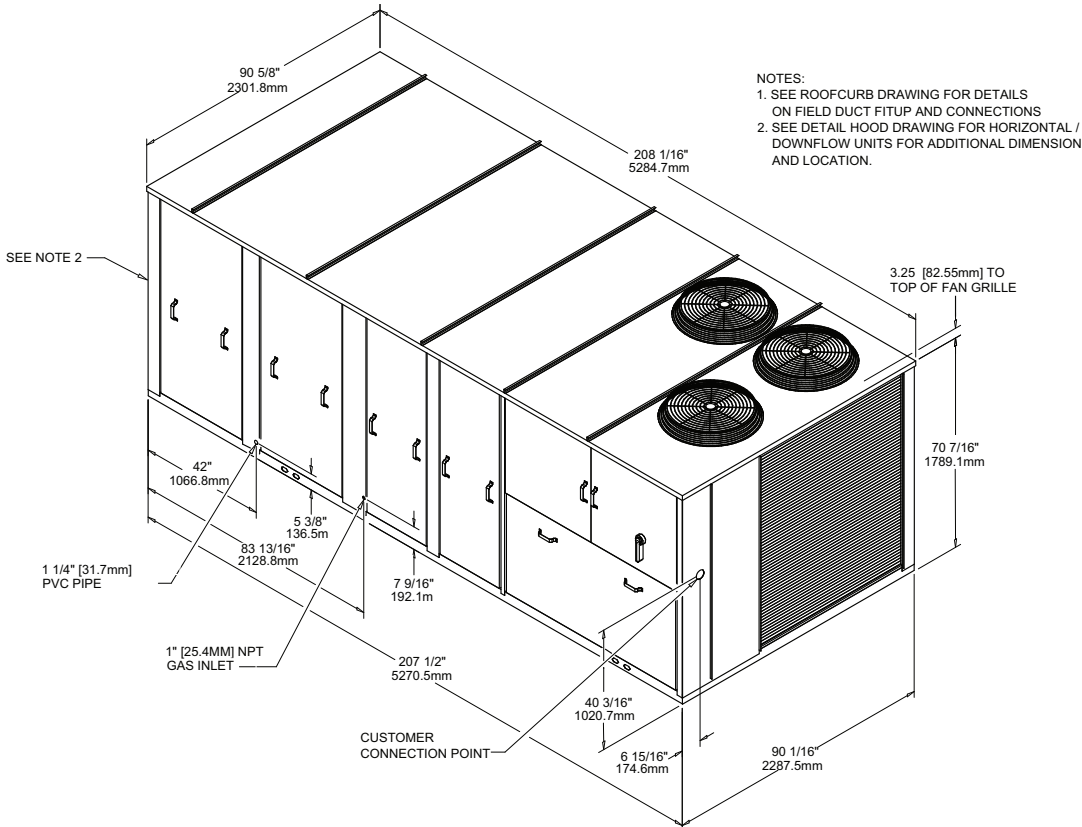


**Notes:**

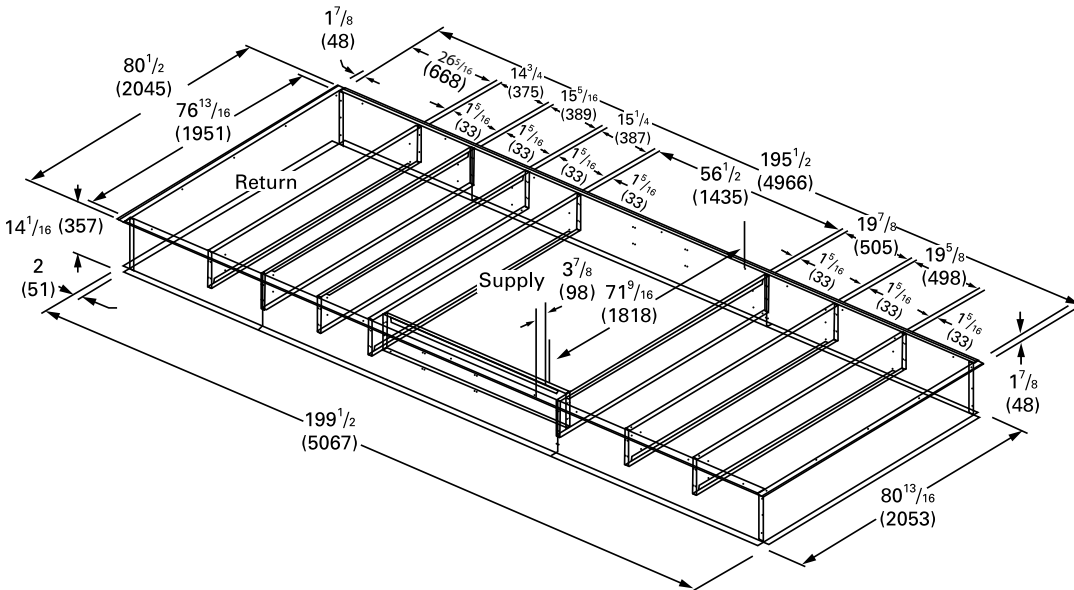
- On horizontal units, the VFD is located between the supply and return ductwork, which makes access limited.
- For combination of horizontal and downflow openings (digit 3 = F or R) see for appropriate downflow dimensions and for appropriate horizontal dimensions.

# Unit Dimensions and Weights

**Figure 7. 60 Hz 27.5-35 tons (YC high heat)**



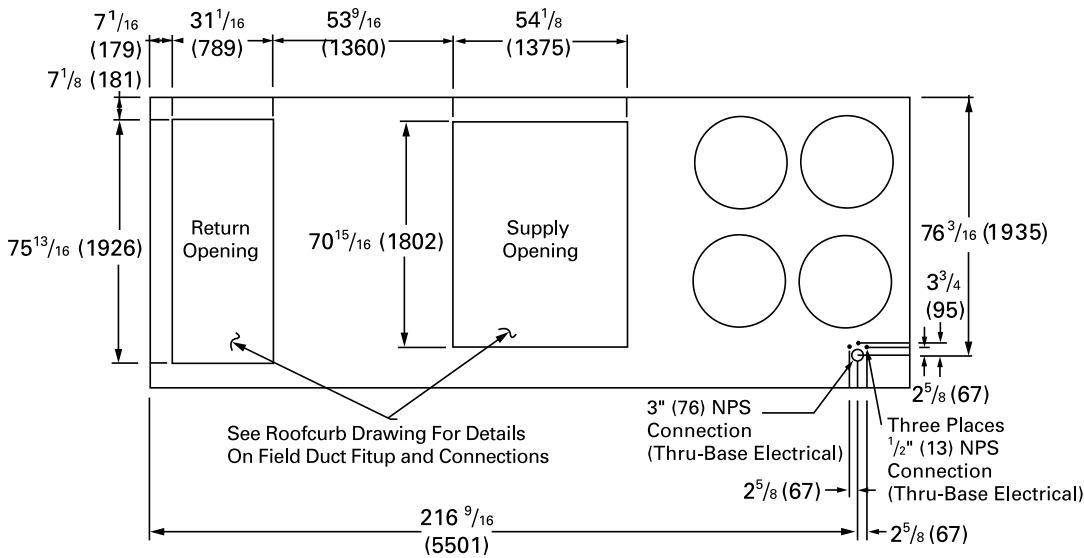
**Figure 8. Curb assembly, 60 Hz 27.5-35 tons (YC high heat)**



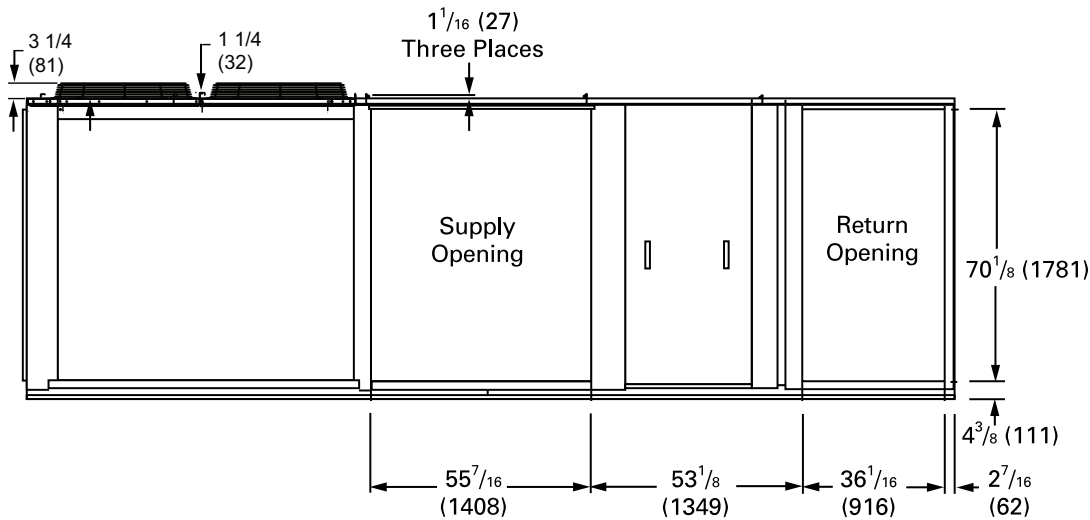
**Note:** Dimensions in ( ) are mm, 1"= 25.4 mm.



**Figure 9. 60 Hz 40-50, 50 Hz 33-42 tons (TCD, TED, YCD low and high heat)**



**Figure 10. Rear view showing duct openings for horizontal supply and return, 60 Hz 40-50, 50Hz 33-42 Tons (TCH, TEH, YCH low and high heat)**

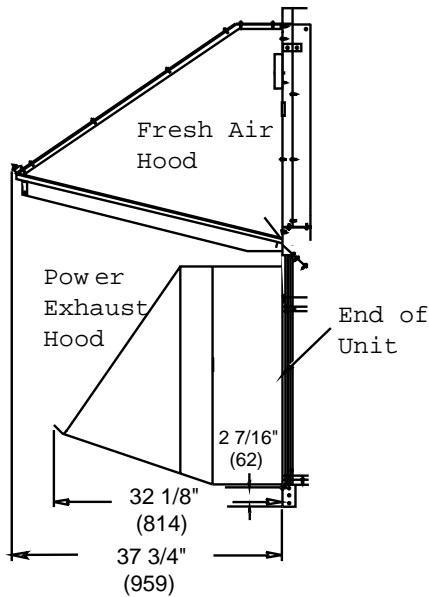


**Notes:**

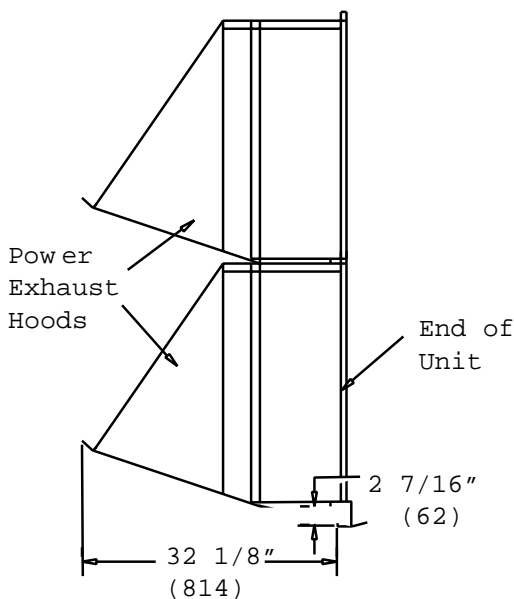
- On horizontal units, the VFD is located between the supply and return ductwork, which makes access limited.
- For combination of horizontal and downflow openings (digit 3 = F or R) see for appropriate downflow dimensions and for appropriate horizontal dimensions.



**Figure 13. Side view showing fresh air and power exhaust hoods for downflow return**

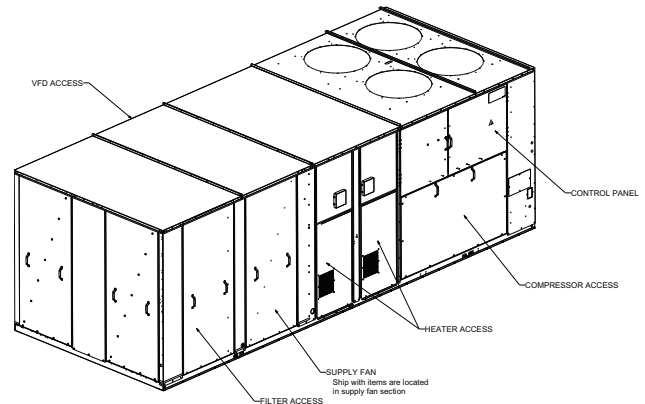


**Figure 14. Side view showing power exhaust hoods for horizontal return**



**Note:** The two horizontal power exhaust hoods and the three horizontal fresh air hoods are located side by side. The fresh air hoods (not shown) extend only 23 15/16" from the end of the unit.

**Figure 15. Location of "Ship With" items for TC\*, TE\*, and YC\* units**



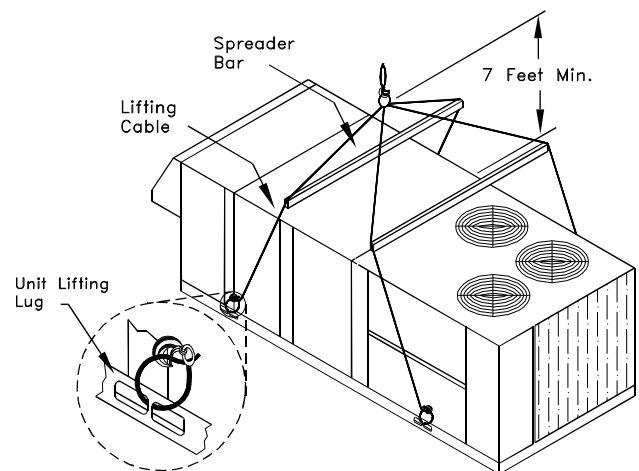
## Unit Rigging and Placement

Use spreader bars as shown in the diagram. Refer to the Installation manual or nameplate for unit weight. Refer to the Installation instructions located inside the control panel for further rigging information.

Verify that the roof curb has the proper gaskets installed and is level and square to assure an adequate curb-to-unit seal.

The units must be as level as possible in order to assure proper condensate flow out of the unit. The maximum side-to-side and end-to-end slope allowable in any application is listed in [Table 2, p. 20](#).

**Figure 16. Unit rigging**





## Unit Dimensions and Weights

**Table 1. Minimum operating clearances installation (horizontal, downflow, and mixed airflow configurations)**

Unit Model (60Hz/50Hz)	Baro. Relief	Power Exhaust	0-25% Man Damper	Econ.	Var. Freq. Drives (VFD's)		Serv. Valves	Thru-the base Elec.	Non- Fused Discon. Switch	Factory GFI with Discon. Switch	Roof Curb		HGRH Coil
					W/O	With					Lo	Hi	
					Bypass								
** (D,F) 330/275	110/50	167/76	50/23	260/117	108/49	114/52	18/8	6/3	30/14	85/38	310/141	330/150	107/49
** (H,R) 330/275	145/65	191/87	50/23	285/128	108/49	114/52	18/8	6/3	30/14	85/38	310/141	330/150	107/49
** (D,F) 360/305	110/50	167/76	50/23	260/117	108/49	114/52	18/8	6/3	30/14	85/38	310/141	330/150	107/49
** (H,R) 360/305	145/65	191/87	50/23	285/128	108/49	114/52	18/8	6/3	30/14	85/38	310/141	330/150	107/49
** (D,F) 420/350	110/50	167/76	50/23	260/117	108/49	114/52	18/8	6/3	30/14	85/38	310/141	330/150	107/49
** (H,R) 420/350	145/65	191/87	50/23	285/128	108/49	114/52	18/8	6/3	30/14	85/38	310/141	330/150	107/49
** (D,F) 480/400	110/50	167/76	50/23	290/131	150/68	158/72	18/8	6/3	30/14	85/38	365/169	365/169	112/51
** (H,R) 480/400	145/65	191/87	50/23	300/135	150/68	158/72	18/8	6/3	30/14	85/38	365/169	365/169	112/51
** (D,F) 600/500	110/50	167/76	50/23	290/131	150/68	158/72	18/8	6/3	30/14	85/38	365/169	365/169	112/51
** (H,R) 600/500	145/65	191/87	50/23	300/135	150/68	158/72	18/8	6/3	30/14	85/38	365/169	365/169	112/51
Con- denser Hail Guards	Ultra Low Leak Econ	Ultra Low Leak 50% Exhaust	Ultra Low Leak 100% Exhaust	eStage, High Efficien- cy									
105/48	112/51	34 / 15	74 / 34	251/114									
105/48	78/35	34 / 15	77 / 35	251/114									
105/48	112/51	34 / 15	74 / 34	251/114									
105/48	78 /35	34 / 15	77 / 35	251/114									
105/48	112/51	34 / 15	74 / 34	175/79									
105/48	78/35	34 / 15	77 / 35	175/79									
130/59	114/52	34 / 15	74 / 34	196/89									
130/59	100/45	34 / 15	84 / 38	196/89									
130/59	114/52	34 / 15	74 / 34	70/32									
130/59	100/45	34 / 15	84 / 38	70/32									

**Table 2. Maximum slope**

Cabinet	End to End (inches)	Side to Side (inches)
"A" (27.5 - 35 Ton Low Heat)	3 1/2	1 5/8
"B" (27.5 - 35 Ton High Heat)	4	1 5/8
"C" (All 40 and 50 Ton Units)	4 1/2	1 5/8

**Note:** Do not exceed these allowances. Correct the improper slope by building up the curb base. The material used to raise the base must be adequate to support both the curb and the unit weight.

**Table 3. Center of gravity**

Unit (60Hz)	Center-of-Gravity (inches)							
	TC		TE		YC Low		YC High	
	X	Y	X	Y	X	Y	X	Y
27.5 Tons	91.0	40.8	91.1	41.0	91.3	40.2	102.9	40.1
30 Tons	91.2	40.9	91.4	41.0	91.5	40.3	103.1	40.1

**Table 3. Center of gravity (continued)**

Center-of-Gravity (inches)								
Unit (60Hz)	TC		TE		YC Low		YC High	
	X	Y	X	Y	X	Y	X	Y
35 Tons	91.9	41.1	92.0	41.3	92.2	40.5	103.7	40.4
40 Tons	114.6	41.2	114.7	41.3	114.3	41.9	115.4	40.6
50 Tons	114.1	40.8	114.3	40.9	114.0	41.5	115.0	40.2

**Notes:**

1. Center-of-gravities shown are for standard efficiency units and include the following features: 10HP supply fan motor, supply fan VFD, 100% economizer, 2" MERV 8 filters, SZVAV system control, GFCI, no exhaust, and hail guards.
2. Center-of-gravities shown are subject to change based on the specific unit configuration.
3. Center-of-gravities shown are approximate and have a  $\pm 10\%$  accuracy. To calculate CG for a specific unit configuration, utilize Trane Select Assist™ or contact your local Trane® sales representative.

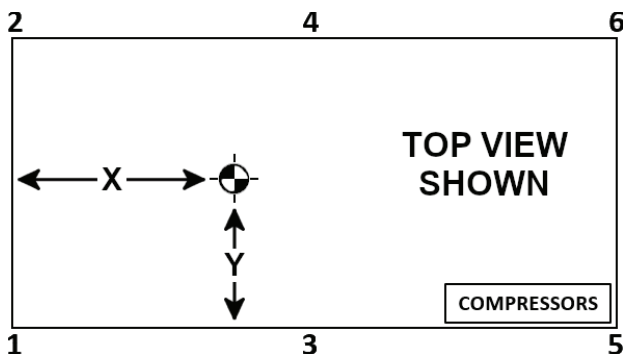
**Table 4. Average unit point load weight (lb)**

Average Unit Point Load Weight (lb)						
Unit (60Hz)	1	2	3	4	5	6
27.5 Tons	880	696	867	683	854	670
30 Tons	878	697	868	687	857	676
35 Tons	874	699	870	695	866	691
40 Tons	1009	818	997	806	985	794
50 Tons	1032	823	1015	807	999	790

**Notes:**

1. Point Loads shown are for standard efficiency units and include the following features: 10HP supply fan motor, supply fan VFD, 100% economizer, 2" MERV 8 filters, SZVAV system control, GFCI, no exhaust, and hail guards.
2. Point Loads shown are subject to change based on the specific unit configuration.
3. Point Loads shown are based on the weights of YC high gas heat units.
4. Point Loads shown are approximate and have a  $\pm 10\%$  accuracy. To calculate point loads for a specific unit configuration, utilize Trane Select Assist™ or contact your local Trane® sales representative.

**Figure 17. Center of gravity**





## Unit Dimensions and Weights

**Table 5. Approximate unit operating weight**

Average Unit Weight (lb)				
Unit (60Hz)	TC	TE	YC Low	YC High
27.5 Tons	4183	4303	4468	4651
30 Tons	4195	4315	4480	4663
35 Tons	4226	4346	4511	4694
40 Tons	4821	5044	5130	5409
50 Tons	4878	5101	5187	5466

**Notes:**

- Weights shown are for standard efficiency units and include the following features: 10HP supply fan motor, supply fan VFD, 100% economizer, 2" MERV 8 filters, SZVAV system control, GFCI, no exhaust, and hail guards.
- Weights shown are subject to change based on the specific unit configuration.
- Weights shown represent approximate operating weights and have a ±10% accuracy. To calculate weight for a specific unit configuration, utilize Trane Select Assist™ or contact your local Trane® sales representative.
- As-configured weights are stamped on unit nameplate.

**Table 6. Approximate operating weights— optional components — lbs./kg**

Unit Model (60Hz/50Hz)	Baro. Relief	Power Exhaust	0-25% Man Damper	Econ.	Var. Freq. Drives (VFD's)		Serv. Valves	Thru-the base Elec.	Non- Fused Discon. Switch	Factory GFI with Discon. Switch	Roof Curb		HGRH Coil
					W/O	With					Lo	Hi	
					Bypass								
** (D,F) 330/275	110/50	167/76	50/23	260/117	108/49	114/52	18/8	6/3	30/14	85/38	310/141	330/150	107/49
** (H,R) 330/275	145/65	191/87	50/23	285/128	108/49	114/52	18/8	6/3	30/14	85/38	310/141	330/150	107/49
** (D,F) 360/305	110/50	167/76	50/23	260/117	108/49	114/52	18/8	6/3	30/14	85/38	310/141	330/150	107/49
** (H,R) 360/305	145/65	191/87	50/23	285/128	108/49	114/52	18/8	6/3	30/14	85/38	310/141	330/150	107/49
** (D,F) 420/350	110/50	167/76	50/23	260/117	108/49	114/52	18/8	6/3	30/14	85/38	310/141	330/150	107/49
** (H,R) 420/350	145/65	191/87	50/23	285/128	108/49	114/52	18/8	6/3	30/14	85/38	310/141	330/150	107/49
** (D,F) 480/400	110/50	167/76	50/23	290/131	150/68	158/72	18/8	6/3	30/14	85/38	365/169	365/169	112/51
** (H,R) 480/400	145/65	191/87	50/23	300/135	150/68	158/72	18/8	6/3	30/14	85/38	365/169	365/169	112/51
** (D,F) 600/500	110/50	167/76	50/23	290/131	150/68	158/72	18/8	6/3	30/14	85/38	365/169	365/169	112/51
** (H,R) 600/500	145/65	191/87	50/23	300/135	150/68	158/72	18/8	6/3	30/14	85/38	365/169	365/169	112/51

Con- denser Hail Guards	Ultra Low Leak Econ	Ultra Low Leak 50% Exhaust	Ultra Low Leak 100% Exhaust	eStage, High Efficien- cy
105/48	112/51	34 / 15	74 / 34	251/114
105/48	78/35	34 / 15	77 / 35	251/114
105/48	112/51	34 / 15	74 / 34	251/114
105/48	78 / 35	34 / 15	77 / 35	251/114
105/48	112/51	34 / 15	74 / 34	175/79
105/48	78/35	34 / 15	77 / 35	175/79
130/59	114/52	34 / 15	74 / 34	- / -
130/59	100/45	34 / 15	84 / 38	- / -
130/59	114/52	34 / 15	74 / 34	- / -
130/59	100/45	34 / 15	84 / 38	- / -



# A2L Information and Installation Requirements

## Installation/Code Compliance Requirements

Building level controls may need to be upgraded/modified to demand leak mitigation actions as described in “[Leak Detection System](#) (Refrigerant charge greater than 3.91 lb per circuit),” p. 27. Those actions include, but are not limited to, fully opening damper and VAV boxes (if present), and disabling electric heat in VAV boxes (if present).

Verify the equipment refrigerant charge is in accordance with the room area limitation as described in Minimum Room Area Limits section.

Ensure that there are labels on the equipment stating it contains a flammable refrigerant.

## A2L Work Procedures

### ⚠ WARNING

#### Risk of Fire — Flammable Refrigerant!

Failure to follow instructions below could result in death or serious injury, and equipment damage.

- To be repaired only by trained service personnel.
- Do not puncture refrigerant tubing.
- Dispose of properly in accordance with federal or local regulations.
- The equipment shall be stored in a room without continuously operating ignition sources.

### ⚠ WARNING

#### Refrigerant under High Pressure!

Failure to follow instructions below could result in an explosion which could result in death or serious injury or equipment damage.

System contains refrigerant under high pressure. Recover refrigerant to relieve pressure before opening the system. See unit nameplate for refrigerant type. Do not use non-approved refrigerants, refrigerant substitutes, or refrigerant additives.

### ⚠ WARNING

#### Hazardous Voltage!

Failure to disconnect power before servicing could result in death or serious injury.

Disconnect all electric power, including remote disconnects before servicing. Follow proper lockout/tagout procedures to ensure the power can not be inadvertently energized. Verify that no power is present with a voltmeter.

The units described in this manual use R-454B refrigerant. Use ONLY R-454B rated service equipment or components with these units. For specific handling concerns with R-454B, contact your local Trane representative.

Installation, repair, removal, or disposal should be performed by trained service personnel.

At all times, Trane’s maintenance and service guidelines shall be followed. If in doubt, contact Trane technical support for assistance.

## Servicing

Prior to initiating work on equipment, check the area with an appropriate refrigerant detector. Ensure the service personnel are properly trained regarding work in potentially toxic or flammable atmospheres. Ensure that the leak detection equipment being used is suitable for use with all applicable refrigerants, i.e. non-sparking, adequately sealed, or intrinsically safe. Be aware that the refrigerant does not contain an odor.

If any hot work is to be conducted on the refrigerating equipment or any associated parts, appropriate fire extinguishing equipment shall be available on hand. A dry powder or CO<sub>2</sub> fire extinguisher should be located adjacent to the charging area.

At all times, Trane’s maintenance and service guidelines shall be followed. If in doubt, contact Trane technical support for assistance.

All maintenance staff and others working in the local area shall be instructed on the nature of the work being carried out. Work in confined spaces shall be avoided.

## Ignition Source Mitigation

Do not use any sources of ignition when working on the refrigeration system.

Keep all ignition sources, including cigarette smoking, away from the site of installation, repair, removal or disposal, during which refrigerant can potentially be released to the surrounding space.

Survey the area around the equipment before initiating work to ensure no flammable hazards or ignition risks are present.

“No Smoking” signs shall be displayed.



## A2L Information and Installation Requirements

---

Do not use devices that can be a source of ignition to accelerate defrosting of components. Use only defrost and cleaning procedures recommended by Trane. Do not pierce or burn.

### Ventilation

Ensure that the area is in the open or that it is adequately ventilated before breaking into the system or conducting any hot work. A degree of ventilation shall continue during the period that the work is carried out. The ventilation should safely disperse any released refrigerant and preferably expel it externally into the atmosphere. If present, check that the ventilation system, including outlets, are operating adequately and are not obstructed.

### Refrigerating Equipment

Refrigerant piping or components should not be installed in locations where substances which may corrode them are present.

Check that equipment hazard markings are visible and legible. Replace them if they are not.

For equipment using secondary fluids, like water or glycol, check that refrigerant is not present in the secondary fluid loop before conducting any hot work.

### Electrical Devices

Do not apply power to the circuit if a fault exists which compromises safety. If the fault cannot be corrected immediately, but it is necessary to continue operation, an adequate temporary solution shall be used. This shall be reported to the owner of the equipment, so all parties are advised.

Initial safety checks shall include:

- Cabling is not subject to wear, corrosion, excessive pressure, vibration, sharp edges, or any other adverse environmental effects. Account for the effects of aging or continual vibration from sources such as compressors or fans.
- Capacitors are discharged. This shall be done in a safe manner to avoid possibility of sparking.
- No live electrical components and wiring are exposed while charging, recovering, or purging the system.
- Verify continuity of earth bonding.
- Replace electrical components with Trane replacement parts, or those meeting the same ratings and qualified for flame arrest protection, UL LZGH2 category.

### Leak Detection

Never use an open flame to detect leaks. A halide torch should not be used. Use only approved leak detection methods per this instruction manual.

The following leak detection methods are deemed acceptable for all refrigerant systems.

Electronic leak detectors may be used to detect refrigerant leaks but, in the case of flammable refrigerants, the sensitivity may not be adequate, or may need re-

calibration. (Detection equipment shall be calibrated in a refrigerant-free area.) Ensure that the detector is not a potential source of ignition and is suitable for the refrigerant used. Leak detection equipment shall be set at a percentage of the LFL gas (25% maximum) is confirmed.

Leak detection fluids are also suitable for use with most refrigerants but the use of detergents containing chlorine shall be avoided as the chlorine may react with the refrigerant and corrode the copper pipe-work.

Examples of leak detection fluids are:

- Bubble method
- Fluorescent method agents

If a leak is suspected, all naked flames shall be removed/ extinguished.

If a refrigerant leak is found which requires brazing, all refrigerant shall be recovered from the system, or isolated (by means of shut off valves) in a part of the system remote from the leak.

### Refrigerant Removal and Evacuation

Ensure that the correct number of cylinders for holding the total system charge is available. All cylinders to be used are designated for the recovered refrigerant and labeled for that refrigerant (special cylinders for the recovery of refrigerant, for example). Cylinders shall be complete with pressure-relief valve and associated shut-off valves in good working order. Empty recovery cylinders are evacuated and, if possible, cooled before recovery occurs.

When breaking into the refrigerant circuit to make repairs – or for any other purpose – conventional procedures shall be used. However, for flammable refrigerants it is important that best practice be followed, since flammability is a consideration.

The following procedure shall be adhered to:

1. Safely remove refrigerant following local and national regulations.
2. Evacuate.
3. Purge the circuit with inert gas.
4. Evacuate (optional for A2L).
5. Continuously flush or purge with inert gas when using flame to open circuit.
6. Open the circuit.

Prior to refrigerant removal, open all appropriate valves, including solenoid and electronic expansion valves (EXVs). Use control settings, where available. When not available, manually open all electronically controlled valves using acceptable service procedures.

The recovery equipment shall be in good working order with instructions available. Equipment shall be suitable for the recovery of the flammable refrigerant. For specific handling concerns, contact the manufacturer. Ensure all hose connections are checked for tightness to avoid refrigerant leaks.



In addition, a set of calibrated weighing scales shall be available and in good working order.

The refrigerant shall be recovered into the correct recovery cylinders if venting is not allowed by local and national codes. Do not mix refrigerants in recovery unit and especially not in cylinders.

Refrigerant recovery unit should be purged with an inert gas after each use or before using with a different refrigerant Class – for example, A2L to A1.

If compressors or compressor oils are to be removed, ensure that they have been evacuated to an acceptable level to make certain that flammable refrigerant does not remain within the lubricant. The compressor body shall not be heated by an open flame or other ignition sources to accelerate this process. When oil is drained from a system, it shall be carried out safely.

The system shall be purged with oxygen-free nitrogen to render the appliance safe for flammable refrigerants. This process might need to be repeated several times. Compressed air or oxygen shall not be used for purging refrigerant systems.

The system shall be vented down to atmospheric pressure to enable work to take place.

The outlet for the vacuum pump shall not be close to any potential ignition sources, and ventilation shall be available.

### Refrigerant Charging

In addition to conventional charging procedures, the following requirements shall be followed.

- Ensure that contamination of different refrigerants does not occur when using charging equipment.
- Hoses or lines shall be as short as possible to minimize the amount of refrigerant contained in them.
- Cylinders shall be kept in an appropriate position according to the instructions.
- Ensure that the refrigerating system is earthed prior to charging the system with refrigerant.
- Label the system when charging is complete (if not already).
- Extreme care shall be taken not to overfill the refrigerating system.

Prior to recharging the system, it shall be pressure-tested with the appropriate purging gas. The system shall be leak-tested on completion of charging but prior to commissioning. A follow up leak test shall be carried out prior to leaving the site.

Prior to refrigerant charging, open all appropriate valves, including solenoid and electronic expansion valves (EXVs). Use control settings, where available. When not available, manually open all electronically controlled valves using acceptable service procedures.

Verify the equipment refrigerant charge is in accordance with the room area limitation as described in Minimum Room Area Limits section.

### Decommissioning

Before carrying out the decommissioning procedure, it is essential that the trained service personnel is completely familiar with the equipment and all its details. It is recommended good practice that all refrigerants are recovered safely. Prior to the task being carried out, an oil and refrigerant sample shall be taken in case analysis is required prior to re-use of recovered refrigerant. It is essential that electrical power is available before the task is commenced.

1. Become familiar with the equipment and its operation.
2. Isolate system electrically.
3. Before attempting the procedure, ensure that:
  - a. Mechanical handling equipment is available, if required, for handling refrigerant cylinders.
  - b. All personal protective equipment is available and being used correctly.
  - c. The recovery process is supervised at all times by a competent person.
  - d. Recovery equipment and cylinders conform to the appropriate standards.
4. Pump down refrigerant system, if possible.
5. If a vacuum is not possible, make a manifold so that refrigerant can be removed from various parts of the system.
6. Make sure that cylinder is situated on the scales before recovery takes place.
7. Start the recovery machine and operate in accordance with instructions.
8. Do not overfill cylinders (no more than 80% volume liquid charge).
9. Do not exceed the maximum working pressure of the cylinder, even temporarily.
10. When the cylinders have been filled correctly and the process completed, make sure that the cylinders and the equipment are removed from site promptly and all isolation valves on the equipment are closed off.
11. Recovered refrigerant shall not be charged into another refrigerating system unless it has been cleaned and checked.
12. When equipment has been decommissioned, attach a signed and dated label stating it has been decommissioned and emptied of refrigerant.
13. Ensure that there are labels on the equipment stating it contains flammable refrigerant.

### A2L Application Considerations

This product is listed to UL standard 60335-2-40, Household and Similar Electrical Appliances – Safety – Part 2-40: Particular Requirements for Electrical Heat Pumps, Air-Conditioners and Dehumidifiers, which defines safe design and use strategies for equipment using A2L



## A2L Information and Installation Requirements

refrigerants. This standard limits the refrigerant concentration in a space in the event of a refrigerant leak. To meet the requirements, the UL standard defines minimum room area, refrigerant charge limit, minimum circulation airflow and/or ventilation airflow requirements, and limits the use of ignition sources in spaces. The standard may require a unit refrigerant leak detection system.

For equipment with R-454B and charge amounts less than or equal to 3.91 lbs per circuit, this UL standard does not prescribe a room area limit and does not require a refrigerant leak detection system or any circulation airflow or ventilation airflow mitigation strategies. However, ignition sources in ductwork must be evaluated.

Depending on the application, a specific requirement of ANSI/ASHRAE Standard 15, Safety Standard for Refrigeration Systems, could be more stringent than UL 60335-2-40 requirements. See *Refrigeration Systems and Machinery Rooms Application Considerations for Compliance with ASHRAE® Standard 15-2022 Application Engineering Manual* (APP-APM001\*-EN) for more information.

### Ignition Sources in Ductwork

Do not install open flames in the ductwork. Hot surfaces exceeding 700°C (1290°F) should not be installed in the ductwork unless the average airflow velocity is not less than 1.0 m/s (200 ft/min) across the heater and proof of airflow is verified before system is energized.

Electric heaters can exceed the surface temperature limit if airflow distribution is poor, or insufficient airflow is provided over the heater.

Surface temperatures of most gas heaters do not exceed the surface temperature limits due to ANSI construction requirements.

### Ignition Sources in Unit

This unit does not contain any ignition sources. All potential ignition sources, (including factory or field installed accessory electric heaters, gas heaters, relays, and contactors) were evaluated during product UL listing.

### Minimum Room Area Limits (Refrigerant charge greater than 3.91 lb per circuit)

Equipment with R-454B charge amounts greater than 3.91 lb per circuit may require additional circulation or ventilation airflow mitigation strategies. In this case, two minimum room area ( $A_{min}$ ) thresholds:

- The first threshold defines when equipment serving a single room is required to provide circulation airflow, either continuous or activated by a leak detection system. A ducted system requires circulation airflow unless the smallest room it serves is larger than the adjusted  $A_{min}$  threshold. This product contains a leak detection system if a circuit charge is greater than 3.91 lbs. As a result, no further leak detection system evaluation is required.
- The second threshold defines when additional ventilation airflow is required. If the room area, A or TA, is below the adjusted  $A_{min}$  or  $TA_{min}$  threshold, additional ventilation is required to remove refrigerant in the event of a leak. Refer to UL 60335-2-40 Clause GG.8 and ANSI/ASHRAE Standard 15 Section 7 for natural and mechanical ventilation requirements.

**Table 7. Minimum room area**

	Tonnage	Efficiency	Minimum Room Area ( $A_{min}$ )	
			Ft <sup>2</sup>	M <sup>2</sup>
TE, YC TC	275, 330	Standard	501	47
	305, 360		501	47
	350, 420		501	47
	400, 480		943	88
	500, 600		937	87
TE, YC TC	275, 330	High	621	58
	305, 360		621	58
	350, 420		621	58
	400, 480		943	88
	500, 600		937	87

**Note:** Minimum Room Area based on 2.2M Installation height and maximum tonnage refrigerant charge.

### Minimum Room Area ( $A_{min}$ ) Adjustments

Use equation below to adjust the minimum room area, as applicable, based on the unit's installation height, altitude, and occupancy level it serves.

$$A_{min.adj} = \text{Nameplate } A_{min} \times \text{Altitude Adj} \times \text{Height Adj} \times F_{occ}$$

Multiply the altitude adjustment factor in the table below by  $A_{min}$  listed on the unit nameplate or in the Installation, Operation, and Maintenance (IOM) manual.

**Table 8. Altitude adjustment factor**

Altitude (ft)	Sea Level to 2000	2001 to 4000	4001 to 6000	6001 to 8000	8001 to 10000	10001 to 12000	12001 to 14000	14001 to 15000	Over 15000
$A_{min}$ Adjustment	1	1.05	1.11	1.17	1.24	1.32	1.41	1.51	1.57

In addition,  $A_{min}$  can be adjusted if the unit is installed in a room at a height that is higher than the minimum height shown on the unit. To adjust  $A_{min}$ , multiply by the ratio of the unit minimum release height (in meters) / actual release height (in meters). Use 0.6 m in the ratio for unit minimum installation heights less than or equal to 0.6 m.

For institutional occupancies, ASHRAE Standard 15 applies an additional adjustment factor  $F_{occ}$  to the amount of a charge allowed in a space. To calculate the adjusted  $A_{min}$  for institutional occupancies, multiply the  $A_{min}$  on the nameplate by two.

### EXAMPLE 1: 20 Ton Packaged Rooftop Multi-Zone VAV System Serving an Institutional Occupancy Space

The packaged unit serves 7600 ft<sup>2</sup> of a nursing home located at an altitude of 4000 ft. The unit has two equally charged 10 ton refrigeration circuits. Each circuit has 12 lbs of refrigerant with a minimum room area requirement of 180 ft<sup>2</sup> with a 2.2 m release height.

$$TA_{min.adj} = 180 \text{ ft}^2 \times 1.05 \times 2 = 378 \text{ ft}^2$$

No additional ventilation is required.

### EXAMPLE 2: 10 Ton Split System Serving a Single Commercial Occupancy Space

The split system serves a 1500 ft<sup>2</sup> manufacturing space at 5000 ft altitude. The final installed charge of the single circuit 10 ton unit is 20 lb. The unit has an open return with a release height of 1 m and ducted supply air. The unit  $A_{min}$  is 660 ft<sup>2</sup>.

$$A_{min.adj} = 660 \text{ ft}^2 \times 1.11 = 733 \text{ ft}^2$$

No additional ventilation is required.

### Determining Room Area (A or TA)

The room area (A) is the room area enclosed by the projection to the floor of the walls, partitions, and doors of the space that the equipment serves. For ducted systems, total room area (TA) of all rooms connected by ducts, may be used instead of A.

Rooms connected by drop ceilings only are not considered a single room.

Rooms on the same floor of the building, and connected by an open passageway, can be considered part of the same room if the passageway is a permanent opening, extends to the floor and is intended for people to walk through.

Adjacent rooms on the same floor of the building and connected by permanent openings in the walls and/or doors between rooms (including gaps between the wall and the floor), can be considered part of the same room if the openings meet the following criteria.

- The opening is permanent and cannot be closed.
- Openings extending to the floor, such as door gaps, need to be at least 20 mm above the floor covering surface.
- Natural ventilations opening areas must meet the requirements of ANSIASHRAE Standard 15-2022, Section 7.2.3.2.

Rooms that are connected by a mechanical ventilation system can be considered a single room area if the mechanical ventilation system meets the requirements of ANSIASHRAE Standard 15-2022, Section 7.6.4.

### Leak Detection System (Refrigerant charge greater than 3.91 lb per circuit)

The leak detection system consists of one or more refrigerant detection sensors. When the system detects a leak, the following mitigation actions will be initiated until refrigerant has not been detected for at least 5 minutes:

- Energize the supply fan(s) to deliver a required minimum amount of circulation airflow.
- Disable compressor operation.
- Provide an output signal that can be used to fully open zone dampers and/or VAV boxes and disable electric heat in VAV boxes.
- Provide an output signal that can be used to energize additional mechanical ventilation (if needed).
- Units without airflow proving will disable electric heat sources.

Building fire and smoke systems may override this function.

If the refrigerant sensor has a fault, is at the end of its life, or is disconnected, the unit will initiate the mitigation actions. Mitigation actions may be verified by disconnecting the sensor.

The refrigerant sensors do not need service. Use only manufacturer-approved sensors when replacement is required.



# Pre-Installation

The checklist listed below is a summary of the steps required to successfully install a Voyager 3 rooftop unit. This checklist is intended to acquaint the installing personnel with what is required in the installation process. It does not replace the detailed instructions called out in the applicable sections of this manual.

## General Unit Requirements

### Downflow/Upflow Models

- An optional roof curb, specifically designed for the Voyager 3 rooftop units is available from Trane. The roof curb kit must be field assembled and installed according to the latest edition of the curb installation guide.
- Assemble and install the roof curb, including necessary gaskets. Make sure the curb is level.
- Install and secure the ductwork to the curb.

### All Units

- Check unit for shipping damage and material shortage. (Refer to “General Information,” p. 11).
- Rigging the unit. Refer to Figure 16, p. 19.
- Placing the unit on curb; check for levelness.
- Ensure that the unit-to-curb seal is tight and without buckles or cracks.
- Install an appropriate drain line to the evaporator condensate drain connections, as required. Refer to Figure 18, p. 29.
- Service Valve Option; See “Starting the Compressor,” p. 66.
- Return/Fresh-air damper adjustment. Refer to “Economizer (O/A) Dampers,” p. 59.
- Exhaust Fan Damper Stop Adjustment. Refer to Exhaust Damper Adjustment figures, beginning with Figure 39, p. 58.

## Electrical Requirements

### ⚠ WARNING

#### Proper Field Wiring and Grounding Required!

Failure to follow code could result in death or serious injury.

All field wiring **MUST** be performed by qualified personnel. Improperly installed and grounded field wiring poses **FIRE** and **ELECTROCUTION** hazards. To avoid these hazards, you **MUST** follow requirements for field wiring installation and grounding as described in NEC and your local/state/national electrical codes.

### ⚠ WARNING

#### Electrical Shock Hazard!

Failure to follow instructions below could result in death or serious injury.

Properly connect the system’s oversized protective earthing (grounding) terminal(s).

- Verify that the electrical power supply characteristics comply with the unit nameplate specifications.
- Inspect all control panel components; tighten any loose connections.
- Connect properly sized and protected power supply wiring to a field supplied/installed disconnect and unit power terminal block HTB1, or to the optional unit-mounted disconnect switch.
- Properly ground the unit.

### Field Installed Control Wiring

Complete the field wiring connections for the constant volume and variable air volume controls as applicable. Refer to “Low Voltage Wiring,” p. 35.

**Important:** All field-installed wiring must comply with NEC and applicable local codes.

## Gas Heat Requirements

Refer to “Installation Piping,” p. 40.

- Gas supply line properly sized and connected to the unit gas train.
- All gas piping joints properly sealed.
- Drip leg Installed in the gas piping near the unit.
- Gas piping leak checked with a soap solution. If piping connections to the unit are complete, do not pressurize piping in excess of 0.50 psig or 14 inches w.c. to prevent component failure.
- Main supply gas pressure adequate.
- Gas heat exhaust clear of any obstructions.



# Installation General Requirements

## Condensate Drain Connection

Each commercial rooftop unit is equipped with one (1) 1-1/4 inch Female NPT (threaded) drain connection.

Refer to “Unit Dimensions and Weights,” p. 12 for the location of the connector. A condensate trap must be installed due to the drain connection being on the “negative pressure” side of the fan. Install a P-Trap at the unit using the guidelines in Figure 18, p. 29.

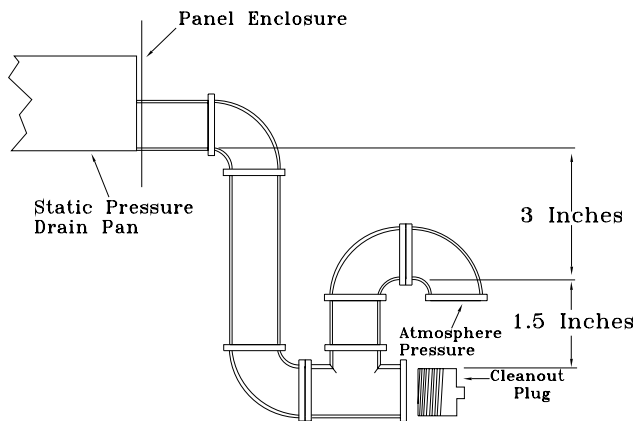
Pitch the drain line at least 1/2 inch for every 10 feet of horizontal run to assure proper condensate flow.

Ensure that all condensate drain line installations comply with applicable building and waste disposal codes.

### Notes:

- For units with optional Condensate Overflow Switch (COF), the switch will not work properly if unit is not level or slightly sloped toward switch.
- To ensure proper condensate flow during operation the unit and the curb must be level.

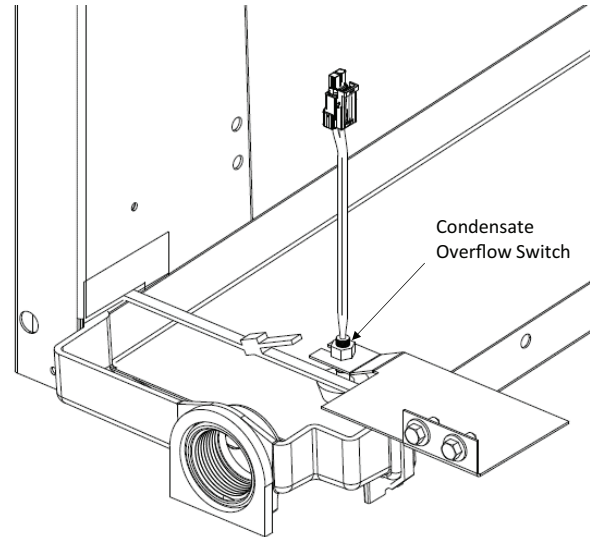
Figure 18. Condensate trap installation



## Condensate Overflow Switch

This switch protects building from condensate overflow damage. It is factory-installed and tested.

Figure 19. Condensate overflow switch location



## O/A Sensor and Tubing Installation

An Outside Air Pressure Sensor is shipped with all units designed to operate on traditional variable air volume applications (non-SZ VAV) and units with Statitrac™.

A duct pressure transducer and the outside air sensor is used to control the discharge duct static pressure to within a customer-specified controlband. Refer to the illustration in Figure 20, p. 30 and the following steps to install the sensor and the pneumatic tubing.

1. Remove the O/A pressure sensor kit located inside the fan section. The kit contains the following items:
  - an O/A static pressure sensor
  - a sensor mounting bracket
  - 50' of 3/16" O.D. pneumatic tubing
  - mounting hardware
2. Using two #10-32 x 1-3/4" screws provided, install the sensor's mounting bracket to the factory provided bracket (near the fan section).
3. Using the #10-32 x 1/2" screws provided, install the O/A static pressure sensor vertically to the sensor bracket.
4. Remove the dust cap from the tubing connector located below the sensor in the vertical support.
5. Attach one end of the 50' x 3/16" O.D. factory provided pneumatic tubing to the sensor's top port, and the other end of the tubing to the connector in the vertical support. Discard any excess tubing.

## Units with Statitrac™

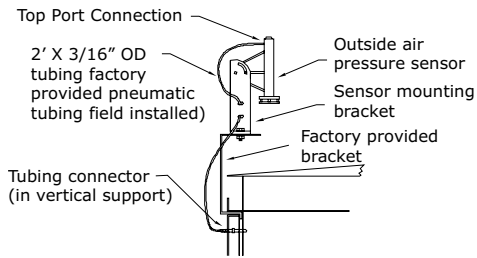
1. Open the filter access door, and locate the Statitrac Transducer Assembly illustrated in Figure 22, p. 31. There are two tube connectors mounted on the left of the solenoid and transducers. Connect one end of the field provided 1/4" (length 50-100 ft.) or 3/8" (length greater than 100 ft.) O.D. pneumatic tubing for the

space pressurization control to the fitting indicated in the illustration.

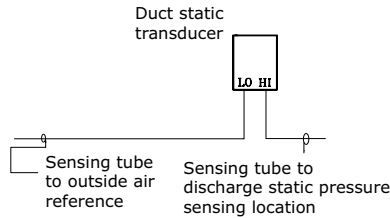
2. Route the opposite end of the tubing to a suitable location inside the building. This location should be the largest open area that will not be affected by sudden static pressure changes.

**Figure 20. Pressure tubing**

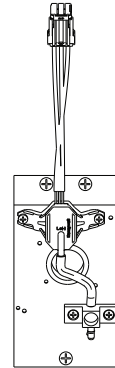
### Atmospheric Pressure Sensing Kit



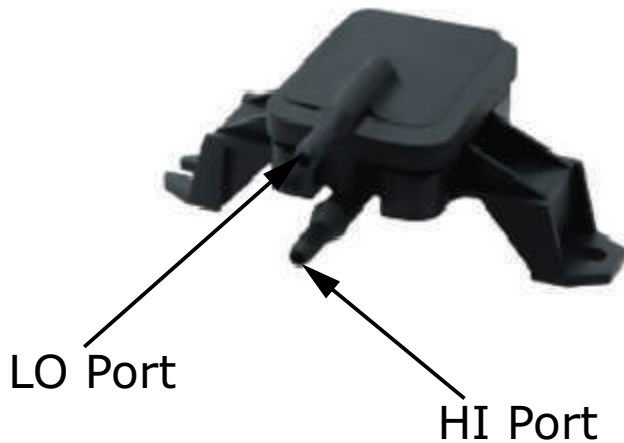
### Duct Pressure Transducer Tubing Schematic



### Duct Pressure Control Component Layout

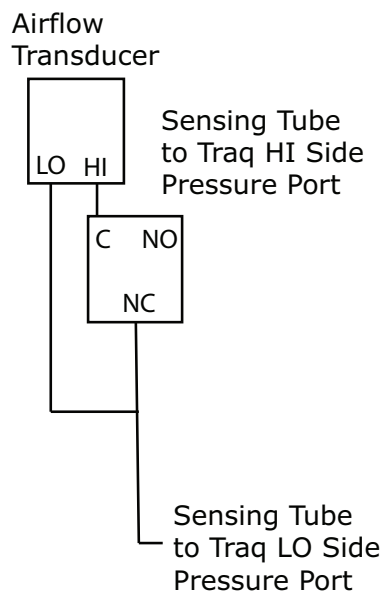
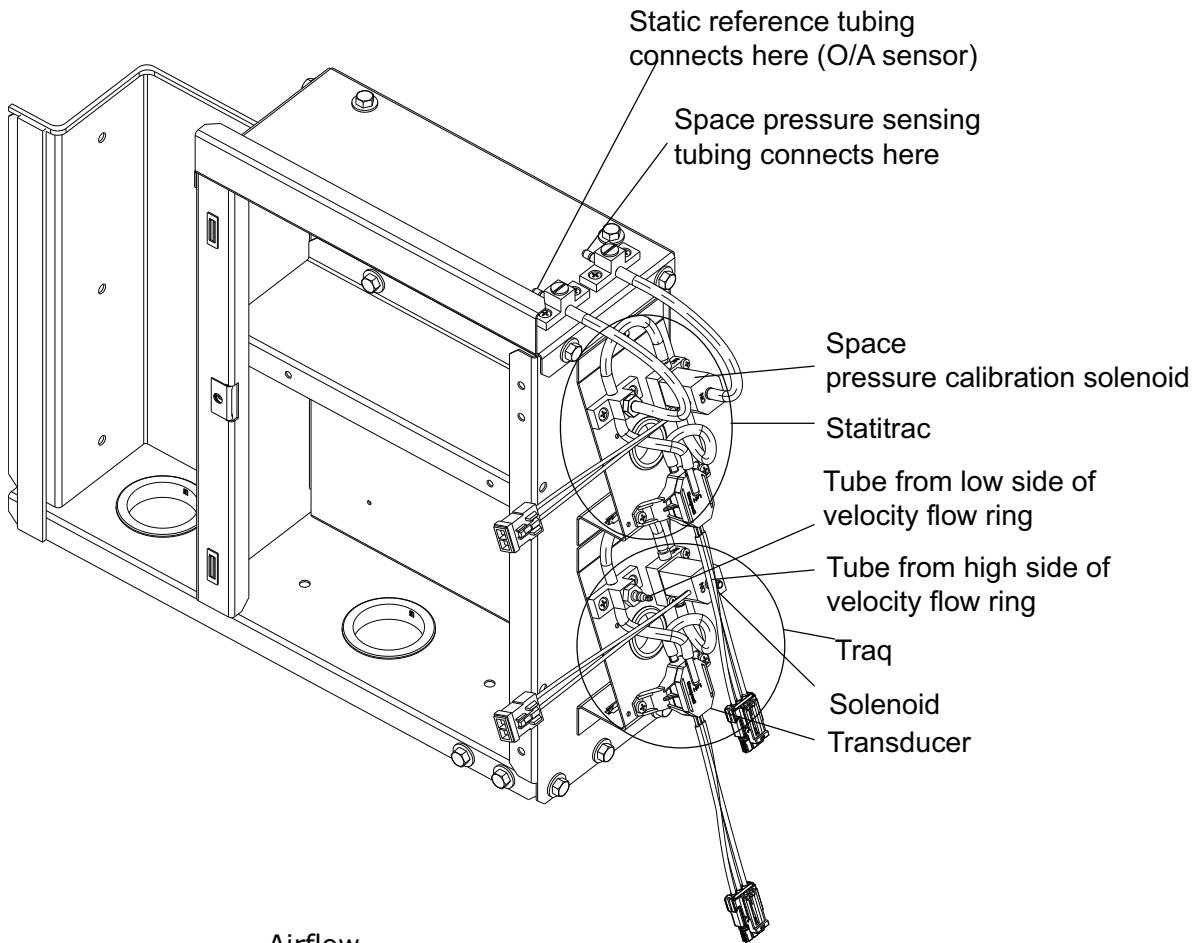


**Figure 21. Supply fan airflow transducer**



**Note:** Transducer is a 5 Vdc differential pressure transducer with a 0 to 5 in. wc range. The output signal is 0.25 to 4 Vdc.

Figure 22. Transducer assembly



**Note:** Statitrac and Traq transducer assembly shown.



# Installation Electrical

## ⚠ WARNING

### Hazardous Voltage!

Failure to disconnect power before servicing could result in death or serious injury.

Disconnect all electric power, including remote disconnects before servicing. Follow proper lockout/tagout procedures to ensure the power can not be inadvertently energized. Verify that no power is present with a voltmeter.

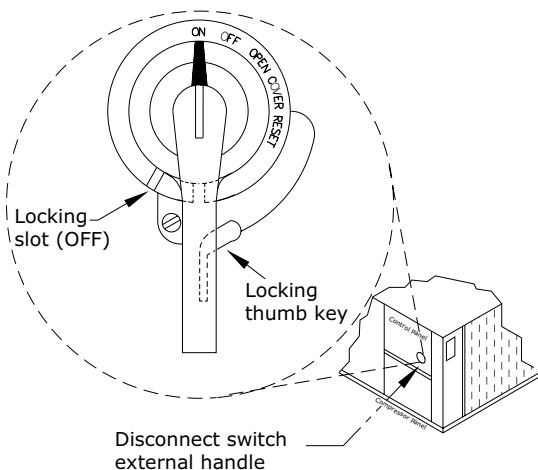
## Disconnect Switch External Handle (Factory Mounted Option)

Units ordered with the factory mounted disconnect switch come equipped with an externally mounted handle. This allows the operator to disconnect power from the unit without having to open the control panel door. The handle location and its three positions are shown below;

- ON - Indicates that the disconnect switch is closed, allowing the main power supply to be applied at the unit.
- OFF - Indicates that the disconnect switch is open, interrupting the main power supply at the unit.
- OPEN COVER/RESET - Turning the handle to this position releases the handle from the disconnect switch, allowing the control panel door to be opened.

Once the door has been opened, it can be closed with the handle in any one of the three positions outlined above, provided it matches the disconnect switch position. The handle can be locked in the “OFF” position. While holding the handle in the “OFF” position, push the spring loaded thumb key, attached to the handle, into the base slot. Place the lock shackle between the handle and the thumb key. This will prevent it from springing out of position.

Figure 23. Disconnect switch



An overall layout of the field required power wiring is illustrated in . To insure that the unit supply power wiring is properly sized and installed, follow the guidelines outlined below.

**Note:** All field installed wiring must conform to NEC guidelines as well as State and Local codes.

Verify that the power supply available is compatible with the unit's name plate ratings for all components. The available power supply must be within 10% of the rated voltage stamped on the nameplate. Use only copper conductors to connect the 3-phase power supply to the unit.

## Main Power Wiring

### ⚠ WARNING

#### Proper Field Wiring and Grounding Required!

Failure to follow code could result in death or serious injury.

All field wiring **MUST** be performed by qualified personnel. Improperly installed and grounded field wiring poses FIRE and ELECTROCUTION hazards. To avoid these hazards, you **MUST** follow requirements for field wiring installation and grounding as described in NEC and your local/state/national electrical codes.

### NOTICE

#### Use Copper Conductors Only!

Failure to use copper conductors could result in equipment damage as the equipment was not designed or qualified to accept other types of conductors.

- Electrical service sizing data can be found on unit name plate and in the product catalog. The electrical service must be protected from over current and short circuit conditions in accordance with NEC requirements. Protection devices must be sized according to the electrical data on the nameplate. Refer to “[Electrical Wire Sizing and Protection Device Equations](#),” p. 34 for determining:
  - The appropriate electrical service wire size based on “Minimum Circuit Ampacity” (MCA),
  - The “Maximum Over current Protection” (MOP) device.
  - The “Recommended Dual Element fuse size” (RDE).
- If the unit is not equipped with an optional factory installed Nonfused disconnect switch, a field supplied disconnect switch must be installed at or near the unit in accordance with the National Electrical Code (NEC)



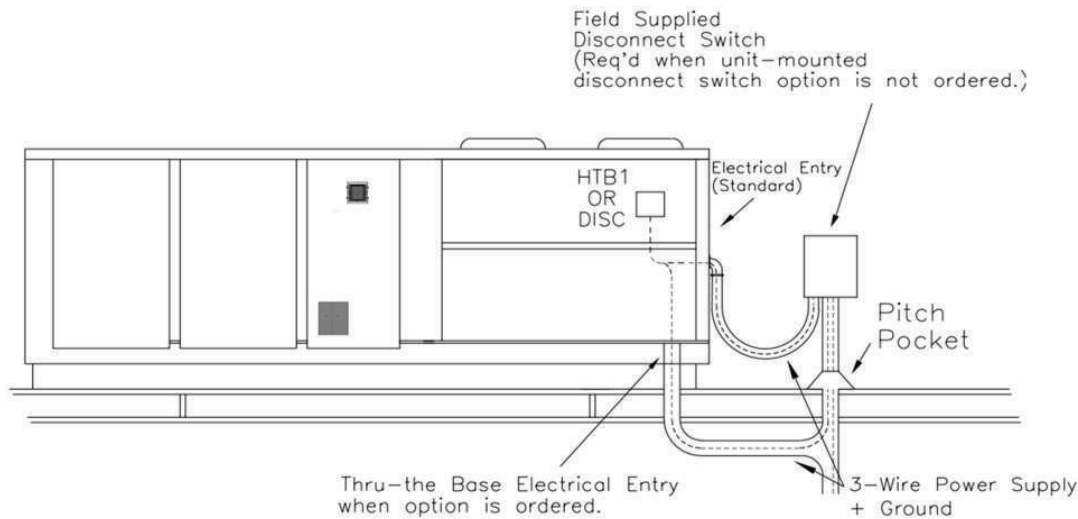
latest edition). Refer to DSS calculations “[Electrical Wire Sizing and Protection Device Equations](#),” p. 34 for determining correct size.

Location for the electrical service entrance is shown in the unit dimensional drawings beginning with . Complete the unit’s power wiring connections onto either the main terminal block HTB1, or the factory mounted nonfused disconnect switch inside the unit control panel.

**Note:** When the factory installed through-the-base option is not used, the installing contractor is required to seal any holes made in the base of the unit to prevent water from leaking into the building.

- Provide proper grounding for the unit in accordance with local and national codes.

**Figure 24. Typical field power wiring**



**Table 9. Customer connection wire range**

CUSTOMER CONNECTION WIRE RANGE							
UNITS WITH MAIN POWER TERMINAL BLOCK ( ALL VOLTAGES)				UNITS WITH MAIN POWER DISCONNECT SWITCH/ CIRCUIT BREAKER (ALL VOLTAGES)			
BLOCK SIZE	WIRE QTY	CONNECTION WIRE RANGE	USAGE	DISCONNECT	WIRE QTY	CONNECTOR WIRE RANGE	USAGE
335 AMP	1	# 6 AWG - 400 MCM	X<= 335 & Z<= 125	100 AMP	1	14 AWG - 3/0	x <= 100 & z <= 95
420 AMP	1	# 2 AWG - 600 MCM	X<= 420 & Z<= 230	250 AMP	1	4 AWG - 350 MCM	100 < x <= 250
x = Max(MCA, 1.15*Heating amps, 1.15*Cooling amps) z = Heater amps + SF amps + EF amps				400 AMP	1	1 AWG- 600 MCM	250 < x <= 400
					2	2 AWG- 250 MCM	
				CIRCUIT BREAKER	WIRE QTY	CONNECTOR WIRE RANGE	USAGE
				100 AMP	1	14 AWG - 3/0	x <= 100 & z <= 95
				250 AMP	1	4 AWG - 350 MCM	100 < x <= 250
				400 AMP	1	1 AWG- 600 MCM	250 < x <= 400
	2	2 AWG- 250 MCM					



## Through-the-Base Electrical (Optional Accessory)

Liquid-tight conduit couplings are secured to the base of the unit for both power and control wiring. Liquid-tight conduit must be field installed between the couplings and the unit control box to prevent water leaks into the building.

### Notes:

- Check for tightness of liquid-tight connectors before unit installation and after electrical installation. Use backup wrench to hold liquid-tight connectors in place while removing caps.
- If the unit is set on the roof curb and temporary auxiliary heat is provided in the building, it is recommended that the electrical and control wiring conduit opening in the control box be temporarily sealed to provide a vapor barrier.

## Electrical Wire Sizing and Protection Device Equations

To correctly size electrical service wiring for your unit, find the appropriate calculations listed below. Each type of unit has its own set of calculations for MCA (Minimum Circuit Ampacity), MOP (Maximum Overcurrent Protection), and RDE (Recommended Dual Element fuse size). Read the load definitions that follow and then find the appropriate set of calculations based on your unit type.

Set 1 is for cooling only and cooling with gas heat units, and set 2 is for cooling with electric heat units.

Load Definitions: (To determine load values, see the Electrical Service Sizing Data Tables.)

LOAD1 = CURRENT OF THE LARGEST MOTOR (COMPRESSOR OR FAN MOTOR)

LOAD2 = SUM OF THE CURRENTS OF ALL REMAINING MOTORS

LOAD3 = CURRENT OF ELECTRIC HEATERS

LOAD4 = ANY OTHER LOAD RATED AT 1 AMP OR MORE

### Set 1. Cooling Only Rooftop Units and Cooling with Gas Heat Rooftop Units

$$MCA = (1.25 \times \text{LOAD1}) + \text{LOAD2} + \text{LOAD4}$$

$$MOP = (2.25 \times \text{LOAD1}) + \text{LOAD2} + \text{LOAD4}$$

Select a fuse rating equal to the MOP value. If the MOP value does not equal a standard fuse size as listed in NEC 240-6, select the next lower standard fuse rating.

**Note:** If selected MOP is less than the MCA, then reselect the lowest standard maximum fuse size which is equal to or larger than the MCA, provided the reselected fuse size does not exceed 800 amps.

$$RDE = (1.5 \times \text{LOAD1}) + \text{LOAD2} + \text{LOAD4}$$

Select a fuse rating equal to the RDE value. If the RDE value does not equal a standard fuse size as listed in NEC 240-6, select the next higher standard fuse rating.

**Note:** If the selected RDE is greater than the selected MOP value, then reselect the RDE value to equal the MOP value.

Keep in mind when determining LOADS that crankcase heaters are disabled in the cooling mode.

$$DSS = 1.15 \times (\text{LOAD1} + \text{LOAD2} + \text{LOAD4})$$

Select a disconnect switch size equal to or larger than the DSS value calculated.

### Set 2. Rooftop Units with Electric Heat

To arrive at the correct MCA, MOP, and RDE values for these units, you must perform two sets of calculations. First calculate the MCA, MOP, and RDE values as if the unit was in cooling mode (use the equations given in Set 1). Then calculate the MCA, MOP, and RDE values as if the unit was in the heating mode as follows.

**Note:** Keep in mind when determining LOADS that the compressors and condenser fans don't run while the unit is in the heating mode and crankcase heaters are disabled in the cooling mode.

• For units using heaters less than 50 kw:  $MCA = 1.25 \times (\text{LOAD1} + \text{LOAD2} + \text{LOAD4}) + (1.25 \times \text{LOAD3})$

• For units using heaters equal to or greater than 50 kw:  $MCA = 1.25 \times (\text{LOAD1} + \text{LOAD2} + \text{LOAD4}) + \text{LOAD3}$

The nameplate MCA value will be the larger of the cooling mode MCA value or the heating mode MCA value calculated above.

$$MOP = (2.25 \times \text{LOAD1}) + \text{LOAD2} + \text{LOAD3} + \text{LOAD4}$$

The selection MOP value will be the larger of the cooling mode MOP value or the heating mode MOP value calculated above.

Select a fuse rating equal to the MOP value. If the MOP value does not equal a standard fuse size as listed in NEC 240-6, select the next lower standard fuse rating.

**Note:** If selected MOP is less than the MCA, then reselect the lowest standard maximum fuse size which is equal to or larger than the MCA, provided the reselected fuse size does not exceed 800 amps.

$$RDE = (1.5 \times \text{LOAD1}) + \text{LOAD2} + \text{LOAD3} + \text{LOAD4}$$

The selection RDE value will be the larger of the cooling mode RDE value or the heating mode RDE value calculated above.

Select a fuse rating equal to the RDE value. If the RDE value does not equal a standard fuse size as listed in NEC 240-6, select the next higher standard fuse rating.

**Note:** If the selected RDE is greater than the selected MOP value, then reselect the RDE value to equal the MOP value.

$$DSS = 1.15 \times (\text{LOAD1} + \text{LOAD2} + \text{LOAD3} + \text{LOAD4})$$

**Note:** Keep in mind when determining LOADS that the compressors and condenser fans don't run while the unit is in the heating mode.

The selection DSS value will be the larger of the cooling mode DSS or the heating mode DSS calculated above.

Select a disconnect switch size equal to or larger than the DSS value calculated.

## Low Voltage Wiring

An overall layout of the various control options available is illustrated in . The required number of conductors for each control device are listed in the illustration.

A typical field connection diagram for the sensors and other options are shown in the following section "Remote Panels and Sensors". These diagrams are representative of standard applications and are provided for general reference only. Always refer to the wiring diagram that shipped with the unit for specific electrical schematic and connection information.

**Note:** All field wiring must conform to NEC guidelines as well as state and local codes.

## Control Power Transformer

### ⚠ WARNING

#### Hazardous Voltage!

Failure to disconnect power before servicing could result in death or serious injury.

Disconnect all electric power, including remote disconnects before servicing. Follow proper lockout/tagout procedures to ensure the power can not be inadvertently energized. Verify that no power is present with a voltmeter.

The 24 volt control power transformers are equipped with internal circuit breakers. They are to be used only with the accessories called out in this manual. If a circuit breaker trips, be sure to turn off all power to the unit before attempting to reset it.

## Field Installed AC Control Wiring

### ⚠ WARNING

#### Hazardous Voltage!

Failure to disconnect power before servicing could result in death or serious injury.

Disconnect all electric power, including remote disconnects before servicing. Follow proper lockout/tagout procedures to ensure the power can not be inadvertently energized. Verify that no power is present with a voltmeter.

### ⚠ WARNING

#### Proper Field Wiring and Grounding Required!

Failure to follow code could result in death or serious injury.

All field wiring **MUST** be performed by qualified personnel. Improperly installed and grounded field wiring poses **FIRE** and **ELECTROCUTION** hazards. To avoid these hazards, you **MUST** follow requirements for field wiring installation and grounding as described in **NEC** and your local/state/national electrical codes.

### NOTICE

#### Use Copper Conductors Only!

Failure to use copper conductors could result in equipment damage as the equipment was not designed or qualified to accept other types of conductors.

### NOTICE

#### Component Failure!

Resistance in excess of 3 ohms per conductor could result in component failure due to insufficient AC voltage supply.

Do not exceed three (3) ohms per conductor for the length of the run.

Table 10. Shielded twisted pair cable part numbers

Part Number	Description
CAB01568	Cable, COMLINK cable with a PVC jacket, 18/1 PR, stranded shield, 25PF plenum, 100 foot length
CAB01569	Cable, COMLINK cable with a PVC jacket, 18/1 PR, stranded shield, 25PF plenum, 1,000 foot length

Before installing any connecting wiring, refer to [Table 11, p. 36](#) for conductor sizing guidelines and;

- Use copper conductors unless otherwise specified.
- Ensure that the AC control voltage wiring between the controls and the unit's termination point does not exceed three (3) ohms/conductor for the length of the run.
- Refer to dimensional information beginning with for the electrical access locations provided on the unit.
- Do not run the AC low voltage wiring in the same conduit with the high voltage power supply wiring.

Be sure to check all loads and conductors for grounds, shorts, and miswiring. After correcting any discrepancies, reset the circuit breakers by pressing the black button located on the left side of the transformer.



## Installation Electrical

**Table 11. AC conductors size**

Distance from unit to control	Recommended wire size
000-460 feet	18 gauge
461-732 feet	16 gauge
733-1000 feet	14 gauge

## Field Installed DC Control Wiring

### **⚠ WARNING**

#### **Hazardous Voltage!**

Failure to disconnect power before servicing could result in death or serious injury.

Disconnect all electric power, including remote disconnects before servicing. Follow proper lockout/tagout procedures to ensure the power can not be inadvertently energized. Verify that no power is present with a voltmeter.

### **⚠ WARNING**

#### **Proper Field Wiring and Grounding Required!**

Failure to follow code could result in death or serious injury.

All field wiring **MUST** be performed by qualified personnel. Improperly installed and grounded field wiring poses **FIRE** and **ELECTROCUTION** hazards. To avoid these hazards, you **MUST** follow requirements for field wiring installation and grounding as described in **NEC** and your local/state/national electrical codes.

### **NOTICE**

#### **Use Copper Conductors Only!**

Failure to use copper conductors could result in equipment damage as the equipment was not designed or qualified to accept other types of conductors.

Before installing the connecting wiring between the components utilizing a DC analog output/input signal and the unit, refer to [Table 12, p. 36](#) for conductor sizing guidelines and;

- Use standard copper conductor thermostat wire unless otherwise specified.
- Ensure that the wiring between the controls and the unit's termination point does not exceed two and a half (2-1/2) ohms/conductor for the length of the run.

**Note:** Resistance in excess of 2 1/2 ohms per conductor can cause deviations in the accuracy of the controls.

- Refer to dimensional drawings beginning with for the electrical access locations provided on the unit.

- Do not run the electrical wires transporting DC signals in or around conduit housing high voltage wires.

**Table 12. DC conductors**

Distance from unit to control	Recommended wire size
000-150 feet	22 gauge
151-240 feet	20 gauge
241-385 feet	18 gauge
386-610 feet	16 gauge
611-970 feet	14 gauge

## LonTalk Communication Interface (Optional)

The Symbio™ controllers supports communication with LonTalk® open protocol applications. An advanced license is required to enable this feature. The LonTalk module is available factory supplied or as a field-installed kit. For more details, refer to *LonTalk® Integration to Precedent™ Packaged Rooftop Air-Conditioners and Axiom™ Water Source Heat Pumps with Symbio™ 700 Controls Integration Guide* (BAS-SVP063\*-EN).

## BACnet Communications Interface (Optional)

The Symbio™ controller provides integrated communication with BACnet® open protocol applications. An advanced license is required to enable this feature. When enabled, the following selections are available: BACnet MS/TP, BACnet IP, or BACnet Zigbee® (Air-Fi®). For more details, refer to *BACnet® and Modbus™ Integration to Precedent™ Packaged Rooftop Air-Conditioners with Symbio™ 700 Controls Integration Guide* (BAS-SVP062\*-EN).

## System Input Devices and Functions

The Symbio™ 700 controller requires a zone sensor or thermostat input to operate the unit in a CVZT or VVZT configuration.

**Note:** Use of a conventional thermostat will reduce unit functionality.

The number of available modes depends on the type of zone sensor or thermostat selected. Descriptions of the basic input devices used with the Symbio 700 network are provided to acquaint the operator with the various modules. Refer to the unit schematic for specific module connections. The following controls are available from the factory for field installation.

## Supply Fan Failure

Supply Fan Failure is determined through the Danfoss VFD Broken-belt Detection parameter (parameter 22-60). When this condition occurs, the Danfoss VFD will communicate the condition over modbus communications to the Symbio Controls. The Symbio 700 controls will then shut down any unit function and enunciate a diagnostic for "Diagnostic: Supply FAN Failure" and "Diagnostic: VFD Supply Fan Broken Belt - 1".

## Clogged Filter Switch (Optional)

The unit mounted clogged filter switch monitors the pressure differential across the return air filters. It is mounted in the filter section and is connected to the Fresh Air Options Module. A diagnostic signal is sent to the controller if the pressure differential across the filters is at least 0.5 inch w.c. The contacts will automatically open when the pressure differential across the filters decreases to approximately 0.4 inch w.c. The clogged filter output is energized when the supply fan is operating and the clogged filter switch has been closed for at least 2 minutes. The system will continue to operate regardless of the status of the filter switch. For further details, refer to Installation Instructions ACC-SVN238\*-EN.

**Note:** *On units equipped with factory installed MERV 13 filters, a clogged filter switch with different pressure settings will be installed. This switch will close when the differential pressure is approximately 0.8 inch w.c. and open when the differential falls to 0.7 inch w.c.*

## Condensate Drain Pan Overflow Switch

A condensate overflow condition will be detected by a condensate overflow float switch. It is connect to the indoor options module. When the condensate level reaches the trip point, the diagnostic condition will be detected. When the condensate overflow input CLOSES for six continuous seconds, the following actions will be taken by the Symbio™ 700 controls:

- An auto-reset diagnostic will be generated. All compressor or heating operations will be disabled immediately. Condenser fans and compressors will be de-energized. Supply fan operation will be shutdown.
- Once the overflow condition has been cleared and the input is OPEN for six seconds, all diagnostic conditions will be cleared. The unit will return to normal operation. Auto-reset clearing will occur twice each time the unit is powered up. On the third occurrence, the unit will initiate a lock-out and require manual reset. If an auto-reset overflow occurs once, but does not occur again for 72 hours, the trip counter will reset allowing more auto-resets to occur.

## Compressor Disable (CPR1/2/3)

This input incorporates the low pressure control (LPC) of the refrigeration circuit.

If this circuit is open before the compressor is started, the compressor will not be allowed to operate. Anytime this

circuit is opened for one continuous second during compressor operation, the compressor for that circuit is immediately turned OFF. The compressor will not be allowed to restart for a minimum of three minutes should the contacts close.

If four consecutive open conditions occur during the first three minutes of operation, the compressor for that circuit will be locked out, a diagnostic communicated to the remote panel (if installed), and a manual reset will be required to restart the compressor.

## High Pressure Control

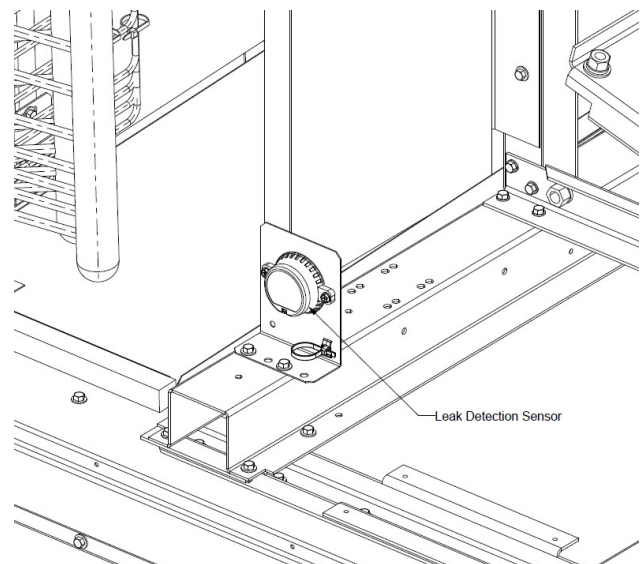
The high pressure controls are wired in series between the compressor outputs on the Symbio™ controller and the compressor contactor coils. If the high pressure control switch opens, the controller senses a lack of current while calling for cooling and locks the compressor out.

If four consecutive open conditions occur during an active call for cooling, the compressor will be locked out, a diagnostic generated, if applicable, and a manual reset required to restart the compressor.

## Leak Detection Sensor

See “,” for additional details about the Leak Detection Sensor.

**Figure 25. Leak detection sensor**



## Zone Sensors

### Wall Mounted Relative Humidity Sensor (BAYSENS036\*)

Field installed, wall mounted humidity sensor that measures temperature and relative humidity. Relative humidity input is used to control activation of dehumidification



### Duct Mounted Relative Humidity Sensor (BAYSENS037\*)

Field installed, duct mounted humidity sensor that measures temperature and relative humidity. Relative humidity input is used to control activation of dehumidification.

### Integrated Comfort System (BAYSENS073\*)

This sensor features remote zone sensing and timed override with override cancellation. It is used with a Trane Integrated Comfort™ building management system.

### Integrated Comfort System (BAYSENS074\*)

This sensor features single setpoint capability and timed override with override cancellation. It is used with a Trane Integrated Comfort™ building management system.

### Remote Zone Sensor (BAYSENS016\*)

This bullet type temperature sensor can be used for outside air (ambient) sensing, return air temperature sensing, supply air temperature sensing, remote temperature sensing (uncovered). Wiring procedures vary according to the particular application and equipment involved. Refer to the unit's wiring diagrams for proper connections.

### Remote Zone Sensor (BAYSENS077\*)

This sensor can be used with BAYSENS106\*, 108\*, 110\*, 800\* Remote Panels. When this sensor is wired to a BAYSENS800\* Remote Panel, wiring must be 18 AWG Shielded Twisted Pair (Belden 8760 or equivalent). Refer to the specific Remote Panel for wiring details.

### Thermostat

The unit must have a thermostat to operate.

- BAYSTAT151  
One Heat/One Cool Auto changeover digital display thermostat.
- BAYSTAT155  
Three Heat/Two Cool Auto changeover display thermostat.
- BAYSENS150  
Three Heat/Two Cool Auto changeover digital display thermostat. Seven day programmable thermostat with night setback.

### High Temperature Sensor (FIAHTST001\*)

This sensor connects to the Symbio™ 700 Emergency Stop Input and provides high limit “shutdown” of the unit. The sensor is used to detect high temperatures due to a high thermal event in the air conditioning or ventilation ducts. The sensor is designed to mount directly to the sheet metal duct. Each kit contains two sensors. The return

air duct sensor (X13100040010) is set to open at 135°F. The supply air duct sensor (X13100040020) is set to open at 240°F. The control can be reset after the temperature has been lowered approximately 25°F below the cutout setpoint.

### Digital Display Zone Sensor (BAYSENS135\*)

LCD display provides heat, cool, auto, on, and off status. Display includes two temperature setpoints, and a lockable setting with °F or °C indicators.

### Touch Screen Programmable Zone Sensor (BAYSENS800)

This sensor uses a BACnet® MS/TP link to communicate zone temperature and setpoints. Sensor includes Auto, Heat, Cool, or Off system switch, as well as Fan Auto or On switch. This is a seven day programmable thermostat with night setback.

#### Notes:

- Not compatible with VAV units. Requires BACnet® communications.
- For additional sensors, refer to the product catalog.

**Note:** BAYSENS800\* with BACnet® enabled on the Symbio™ controller will report fault detection and diagnostics at the zone sensor. This functionality is only applicable if the customer does not have a building management system, and the unit is running standalone with the BAYSENS800.

### Air-Fi Wireless Communication and Sensors (BAYWCII00\*, BAYWCII202\*, BAYSENS202\*, BAYSENS203\*, BAYSENS212\*, BAYSENS213\*, BAYSENS230\*, BAYSENS154\*, BAYCO2K200\*)

By using a Wireless Communication Interface (WCI) with an Advanced Symbio 700 Control, the unit can wirelessly connect to a Trane system control, unit controls, and zone sensors via BACnet/Zigbee protocol. The WCI replaces the need for communications wire in all system applications. Wireless zone sensors (WCS) are capable of sensing temperature, humidity, CO<sub>2</sub>, and occupancy. Units can be configured with and without a display for local adjustment.

### Evaporator Frost Control

Frost is standard on all Voyager 3 27.5 to 50 ton units.

### Discharge Line Temp Switch (DLTS)

The DLTS is looped in series with HPC and LPC. It prevents the compressor from overheating (over 300°F

dome temp) in case of indoor fan failure (cooling) or outdoor fan failure (heating).

## Phase Monitor

This sensor monitors the voltage between the three conductors of the 3-phase power supply. Two LED lights are provided:

- The green light indicates that a balanced 3-phase supply circuit is properly connected.
- The red light indicates that unit operation has been prevented. There are two conditions that will prevent unit operation:
  - The power supply circuit is not balanced with the proper phase sequence of L1, L2, L3 for the three conductors of a three phase circuit.
  - The line to line voltage is not between 180 volts and 633 volts.



# Installation Piping

## General Requirements

### ⚠ WARNING

#### Hazardous Gases and Flammable Vapors!

Failure to observe the following instructions could result in exposure to hazardous gases, fuel substances, or substances from incomplete combustion, which could result in death or serious injury. The state of California has determined that these substances may cause cancer, birth defects, or other reproductive harm.

Improper installation, adjustment, alteration, service or use of this product could cause flammable mixtures or lead to excessive carbon monoxide. To avoid hazardous gases and flammable vapors follow proper installation and setup of this product and all warnings as provided in this manual.

All internal gas piping for YC\* rooftop units are factory installed and leak tested. Once the unit is set into place, a gas supply line must be field installed and connected to the gas train located inside the gas heat compartment.

Access holes are provided on the unit as shown in [Figure 15, p. 19](#) to accommodate side panel entry. Following the guidelines listed below will enhance both the installation and operation of the furnace.

**Note:** In the absence of local codes, the installation must conform with the American National Standard Z223.1a of the National Fuel Gas Code, (latest edition).

1. To assure sufficient gas pressure at the unit, use to determine the appropriate gas pipe size for the heating capacity listed on the unit's nameplate.

If a gas line already exists, verify that it is sized large enough to handle the additional furnace capacity.

2. Take all branch piping from any main gas line from the top at 90 degrees or side at 45 degrees to prevent moisture from being drawn in with the gas.
3. Ensure that all piping connections are adequately coated with joint sealant and properly tightened. Use a piping compound that is resistant to liquid petroleum gases.
4. Provide a drip leg near the unit.

### NOTICE

#### Gas Valve Damage!

Failure to follow instructions below could result in gas valve damage from incorrect gas pressures, irregular pulsating flame patterns, burner rumble, and potential flame outages.

Use a pressure regulator to properly regulate gas pressure. DO NOT oversize the regulator.

5. Install a pressure regulator at the unit that is adequate to maintain 7" w.c. for natural gas and 11" w.c. for LP gas while the unit is operating in the "High Heat" mode.
6. A minimum inlet gas pressure of 7" w.c. for natural gas and 10" w.c. for LP gas is required at the low gas pressure switch while operating in the "High Heat" mode. If inlet gas pressure is too low, furnace may fail to ignite.

**Note:** Gas pressure in excess of 14" w.c. or 0.5 psig will damage the gas train.

### ⚠ WARNING

#### Explosion Hazard!

Failure to follow safe leak test procedures below could result in death or serious injury or equipment or property-only-damage.

Never use an open flame to detect gas leaks. Use a leak test solution for leak testing.

7. Leak test the gas supply line using a soap-and-water solution or equivalent before connecting it to the gas train.
8. Pressure test the supply line before connecting it to the unit to prevent possible gas valve damage and the unsafe operating conditions that will result.

**Note:** Do not rely on gas train shutoff valves to isolate the unit while conducting gas pressure/leak test. These valves are not designed to withstand pressures in excess of 14" w.c. or 0.5 psig.

## Connecting the Gas Supply Line to the Furnace Gas Train

Follow the steps below to complete the installation between the supply gas line and the furnace. Refer to for the Gas Train configuration.

1. Connect the supply gas piping using a "ground-joint" type union to the furnace gas train and check for leaks.
2. Provide adequate support for the field installed gas piping to avoid stressing the gas train and controls.
3. Adjust the inlet supply gas pressure to the recommended 7" for natural gas or 11" w.c. for LP gas while operating in "High Heat" mode.

**Table 13. Specific gravity multiplier**

Specific Gravity	Multiplier
0.5	1.1
0.55	1.04
0.6	1
0.65	0.96



**Table 14. Sizing natural gas pipe mains and branches**

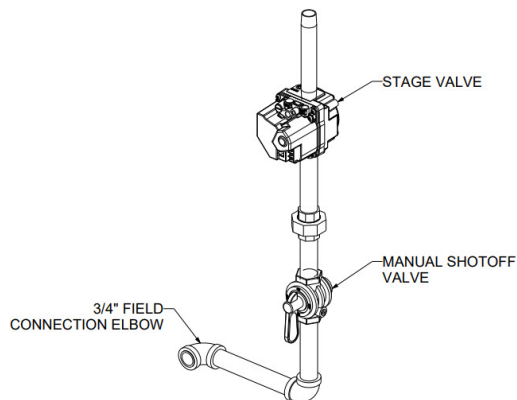
Gas Supply Pipe Run (ft)	Gas Input (Cubic Feet/Hour) <sup>(a)</sup>					
	1-1/4" Pipe	1-1/2" Pipe	2" Pipe	2-1/2" Pipe	3" Pipe	4" Pipe
10	1050	1600	3050	4800	8500	17500
20	730	1100	2100	3300	5900	12000
30	590	890	1650	2700	4700	9700
40	500	760	1450	2300	4100	8300
50	440	670	1270	2000	3600	7400
60	400	610	1150	1850	3250	6800
70	370	560	1050	1700	3000	6200
80	350	530	990	1600	2800	5800
90	320	490	930	1500	2600	5400
100	305	460	870	1400	2500	5100
125	275	410	780	1250	2200	4500
150	250	380	710	1130	2000	4100
175	225	350	650	1050	1850	3800
200	210	320	610	980	1700	3500

**Notes:**

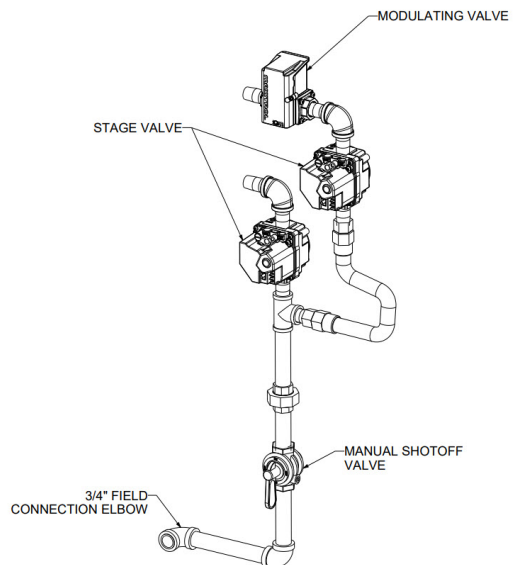
1. If more than one unit is served by the same main gas supply, consider the total gas input (cubic feet/hr.) and the total length when determining the appropriate gas pipe size.
2. Obtain the Specific Gravity and BTU/Cu.Ft. from the gas company.
3. The following example demonstrates the considerations necessary when determining the actual pipe size. Example: A 40' pipe run is needed to connect a unit with a 500 MBH furnace to a natural gas supply having a rating of 1,000 BTU/Cu.Ft. and a specific gravity of 0.60.  $Cu.Ft/ Hour = [(Furnace MBH Input) / (Gas BTU/Cu.Ft.)] \times Multiplier$ .  $Cu.Ft/ Hour = 500$ . This table indicates that a 1-1/4" pipe is required.

<sup>(a)</sup> Table is based on a specific gravity of 0.60. Use previous table or the specific gravity of the local gas supply.

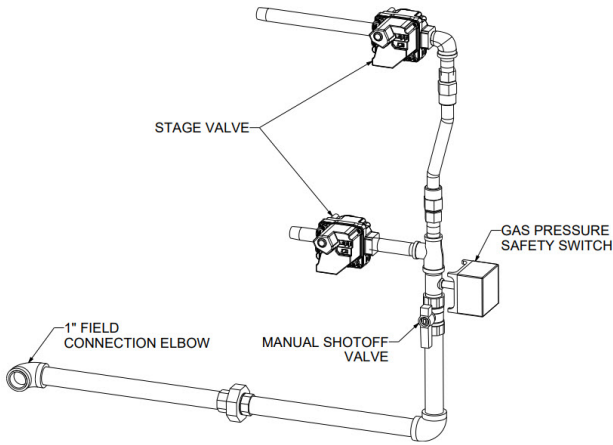
**Figure 26. 350MBh 2-stage gas train**



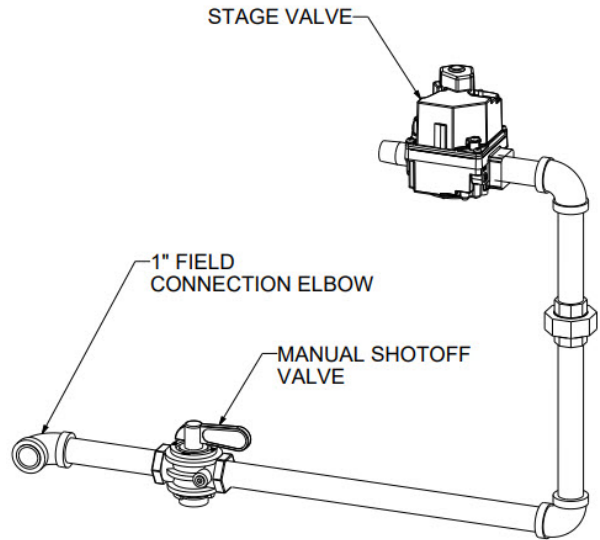
**Figure 27. 350MBh Mod gas train**



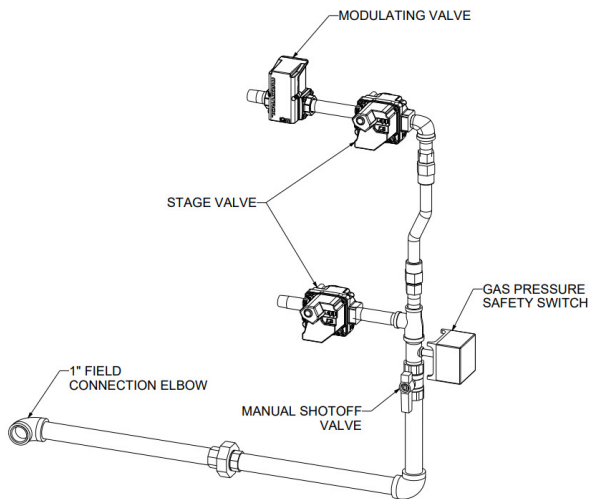
**Figure 28. 600MBh 2-stage gas train**



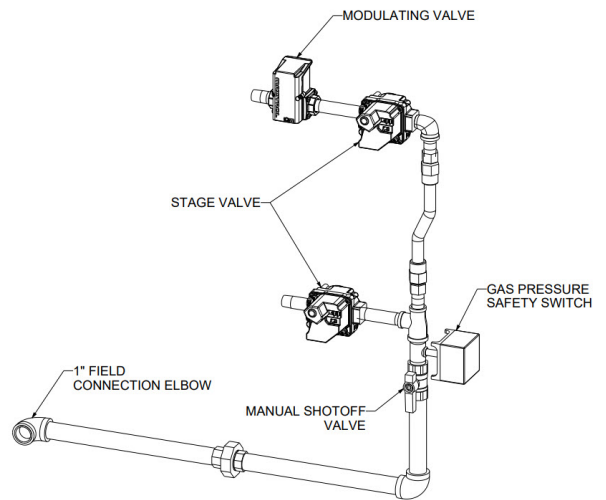
**Figure 30. 400MBh 2-stage gas train**



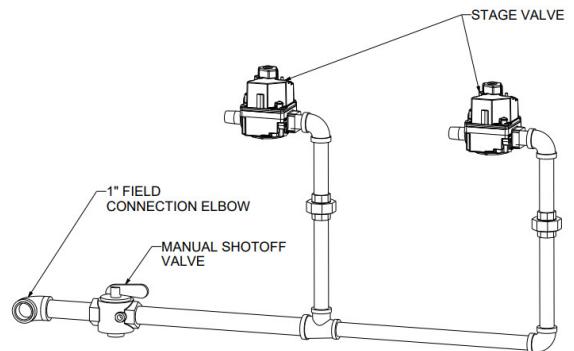
**Figure 29. 600MBh Mod gas train**

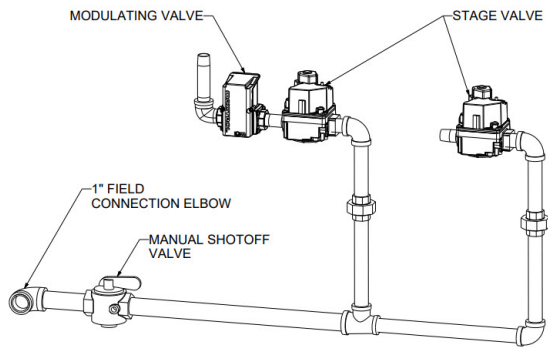


**Figure 31. 400MBh Mod gas train**



**Figure 32. 800MBh 2-stage gas train**



**Figure 33. 800MBh Mod gas train**

# Startup

## Symbio Service and Installation Mobile App

The Symbio™ Service and Installation mobile app is accessible through mobile devices (phones and tablets) via Bluetooth connectivity or via Trane Connect. The intuitive mobile app feels natural to technicians and operators. They will quickly be able to view equipment status and alarms, perform startup tasks, change configurations, test the equipment's performance in specific modes, and much more. Free for download from App Store (Apple iOS) and Google Play (Android devices).

**Figure 34. Symbio Service and Installation app**



To download the Symbio™ Service and Installation Mobile App scan the code with a mobile phone camera or navigate to the app store and search for Symbio.

**Figure 35. Download the Symbio Service and Installation app**

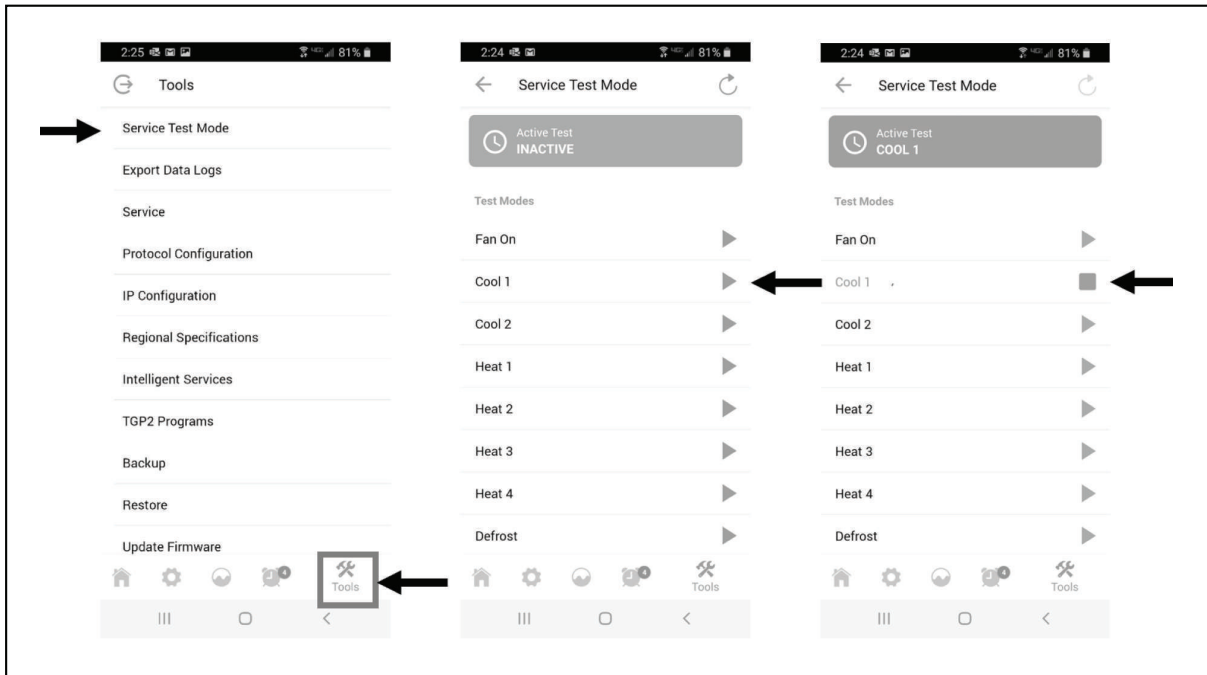


## Symbio Controls

The Symbio™ 700 supports a Service Test Mode that can be used to energize the various components of the system, either to support general system startup tasks or to support troubleshooting. The user can initiate Service Test Mode through the controller user interfaces, including the Symbio Service and Installation mobile application.

The modes shown below can be initiated. Depending on the equipment configuration, the controller will energize the appropriate outputs. A user-selected timeout value will determine how long the controller will remain in any given state once initiated. For detailed information on how each Service Test State is interpreted based on the equipment's configuration, see BAS-APG048\*-EN, Symbio 700 for Voyager 3 Packaged Rooftop Air-Conditioners Application Guide.

**Figure 36. Symbio 700 service test mode**



## Hot Gas Reheat

### **⚠ WARNING**

#### **Live Electrical Components!**

Failure to follow all electrical safety precautions when exposed to live electrical components could result in death or serious injury.

When it is necessary to work with live electrical components, have a qualified licensed electrician or other individual who has been properly trained in handling live electrical components perform these tasks.

Set the unit to the Open Reheat Valve step within Service Test. Once the unit is in the reheat test mode, verify that the reheat valve opens to 85% position and cooling valve closes to 15% position and that the supply temperature rises 10°F more than when in cooling mode stage 2.

The number of outdoor fan running depends on outdoor ambient temperature while in hot gas reheat.

1. Clamp an amp meter around one of 1st stage heater power wires at the heater contactor.
2. Using the Service Test Guide in , continue the SERVICE TEST start-up procedure for each compressor circuit.

Select the next desired Service Test Mode if continuing from previous component start up or exit Service Test if complete.

## Final System Setup

After completing all of the pre-start and startup procedures outlined in the previous sections (i.e., operating the unit in each of its modes through all available stages of cooling and heating), perform these final checks before leaving the unit:

- Verify that the Remote panel “System” selection switch, “Fan” selection switch, and “Zone Temperature” settings for automatic operation are correct.
- Inspect the unit for misplaced tools, hardware, and debris.
- Verify that all exterior panels including the control panel doors and condenser grilles are secured in place.
- Close the main disconnect switch or circuit protector switch that provides the supply power to the unit’s terminal block or the unit mounted disconnect switch.

### **⚠ WARNING**

#### **Safety Alert!**

Failure to follow instructions below could result in death or serious injury.

In addition to the following tasks, you **MUST**:

- Follow all instructions in the unit’s *Installation, Operation, and Maintenance* manual, including warnings, cautions, and notices.
- Perform all required tasks in any applicable **Service Alerts and Service Bulletins**.
- Review and understand all information provided in **Submittals and Design Specifications**.

## Preparing the Unit for Operation

Be sure to complete all of the procedures described in this section before starting the unit for the first time.

Use the checklist provided below in conjunction with the “Installation Checklist” to ensure that the unit is properly installed and ready for operation.

### **⚠ WARNING**

#### **Hazardous Voltage!**

Failure to disconnect power before servicing could result in death or serious injury.

Disconnect all electric power, including remote disconnects before servicing. Follow proper lockout/tagout procedures to ensure the power can not be inadvertently energized. Verify that no power is present with a voltmeter.

- Check all electrical connections for tightness and “point of termination” accuracy.
- Verify that the condenser airflow will be unobstructed.
- Check the compressor crankcase oil level. Oil should be visible in the compressor oil sight glass. The oil level may be above the sight glass prior to the initial start. Use appropriate lighting (flashlight) to verify the presence of oil.
- Prior to unit startup allow the crankcase heater to operate a minimum of 8 hours to remove liquid refrigerant from the compressor sump.
- Optional Service Valves - Verify that the discharge service valve and suction service valve fully open on each circuit.
- Check the supply fan belts for proper tension and the fan bearings for sufficient lubrication. If the belts require adjustment, or if the bearings need lubricating, refer to the Maintenance section of this manual for instructions.
- Inspect the interior of the unit for tools and debris and install all panels in preparation for starting the unit.



## Startup

### Electrical Phasing

Unlike traditional reciprocating compressors, scroll compressors are phase sensitive. Proper phasing of the electrical supply to the unit is critical for proper operation and reliability.

The compressor motor is internally connected for clockwise rotation with the incoming power supply phased as A, B, C. Proper electrical supply phasing can be quickly determined and corrected before starting the unit by using an instrument such as an Ideal - Sperry 61-520 Phase Sequence Indicator and following the steps below:

#### **⚠ WARNING**

##### **Hazardous Voltage!**

**Failure to disconnect power before servicing could result in death or serious injury.**

**Disconnect all electric power, including remote disconnects before servicing. Follow proper lockout/tagout procedures to ensure the power can not be inadvertently energized. Verify that no power is present with a voltmeter.**

- Open the disconnect switch or circuit protector switch that provides the supply power to the unit's power terminal block or to the unit mounted disconnect switch.
- To be consistent with the compressor leads, connect the phase sequence indicator leads to the terminal block or unit mounted disconnect switch as follows;

**Table 15. Phase sequence leads**

Phase Sequence Leads	Unit Power Terminal
Brown (phase A)	L1
Orange (phase B)	L2
Yellow (Phase C)	L3

- Turn the "System" selection switch to the "Off" position and the "Fan" selection switch (if Applicable) to the "Auto" position.
- Close the disconnect switch or circuit protector switch that provides the supply power to the unit's power terminal block or unit mounted disconnect switch.

#### **⚠ WARNING**

##### **Live Electrical Components!**

**Failure to follow all electrical safety precautions when exposed to live electrical components could result in death or serious injury.**

**When it is necessary to work with live electrical components, have a qualified licensed electrician or other individual who has been properly trained in handling live electrical components perform these tasks.**

HIGH VOLTAGE IS PRESENT AT TERMINAL BLOCK HTB1 OR UNIT DISCONNECT SWITCH.

- Observe the ABC and CBA phase indicator lights on the face of the sequencer. The ABC indicator light will glow if the phase is ABC. If the CBA indicator light glows, open the disconnect switch or circuit protection switch and reverse any two power wires.
- Restore main electrical power and recheck phasing. If the phasing is correct, open the disconnect switch or circuit protection switch and remove the phase sequence indicator.

### Voltage Supply and Voltage Imbalance

#### Supply Voltage

Electrical power to the unit must meet stringent requirements for the unit to operate properly. Measure each leg (phase-to-phase) of the power supply. Each reading must fall within the utilization range stamped on the unit nameplate. If any of the readings do not fall within the proper tolerances, notify the power company to correct this situation before operating the unit.

#### Voltage Imbalance

Excessive voltage imbalance between phases in a three phase system will cause motors to overheat and eventually fail. The maximum allowable voltage imbalance is 2%. Measure and record the voltage between phases 1, 2, and 3 and calculate the amount of imbalance as follows:

% Voltage Imbalance =  $[(AV - VD)/AV] \times 100$  where;

AV (Average Voltage) =  $(\text{Volt 1} + \text{Volt 2} + \text{Volt 3}) / 3$

Volt 1, Volt 2, Volt 3 = Line Voltage Readings

VD = Line Voltage reading that deviates the farthest from the average voltage.

##### **Example:**

- If the voltage readings of the supply power measured 221, 230, and 227, the average volts would be:  $(221 + 230 + 227) / 3 = 226 \text{ Avg}$
- VD (reading farthest from average) = 221
- The percentage of imbalance equals:  $[(226 - 221) / 226] \times 100 = 2.2\%$

The 2.2% imbalance in this example exceeds the maximum allowable imbalance of 2.0%. This much imbalance between phases can equal as much as a 20% current imbalance with a resulting increase in motor winding temperatures that will decrease motor life.

If the voltage imbalance at the job site is over 2%, notify the proper agencies to correct the voltage problem to within 2.0% before operating this equipment.

### Starting the Unit

Before closing the main power disconnect switch, insure that the "System" selection switch is in the "Off" position and the "Fan" selection switch for Constant Volume or SZ VAV units is in the "Auto" position.

Close the main power disconnect switch and the unit mounted disconnect switch, if applicable.

**⚠ WARNING****Live Electrical Components!**

Failure to follow all electrical safety precautions when exposed to live electrical components could result in death or serious injury.

When it is necessary to work with live electrical components, have a qualified licensed electrician or other individual who has been properly trained in handling live electrical components perform these tasks.

HIGH VOLTAGE IS PRESENT AT TERMINAL BLOCK HTB1 OR UNIT DISCONNECT SWITCH.

Upon powering the unit, the Symbio™ 700 performs self diagnostic checks to ensure all internal controls are functional. When the user interface is ready or the mobile app is connected to the Symbio 700 controls, use the following test procedure to start the unit at the control panel. Each test step can be activated individually by selecting the unit operating stage desired. The unit can be left in any test step for up to one hour (adjustable to values between 1 and 120 minutes) before Service Test will automatically terminate. Once Service Test has been terminated, a system reset will occur and the unit will revert to the system control (for example, zone temperature for Multi-speed and Single Zone VAV units or discharge air temperature for Multi-zone VAV units).

**Table 16. Service test state request**

Device Request / Service Test Step	Supply fan On/Off request	Supply fan speed request (VZT, CVZT)	Supply fan speed request (VVDA) <sup>(a)</sup>	VAV box relay request (VVDA)	Outdoor air damper position request	Compressor cool stage request	Aux heat stage request	Relief fan On/Off request	Relief damper position request	Reheat pumpout solenoid On/Off request <sup>(b)</sup>	Reheat valve 1 request <sup>(c)</sup>	Heat cool mode status (VZT, CVZT)	Heat cool mode status (VVDA) <sup>(d)</sup>
Inactive	In Control	In Control	In Control	In Control	In Control	In Control	In Control	In Control	In Control	In Control	In Control	In Control	In Control
Fan On	ON	Min	Min	Open	Min	0	0	In Control	Min	OFF	0	Test	Maximum Heat
Fan On Econ Open	ON	Min	Min	Open	100	0	0	In Control	100	OFF	0	Test	Maximum Heat
Ventilation Low Fan Speed	ON	Min	Min	Open	Design Min	0	0	In Control	Min	OFF	0	Test	Maximum Heat
Ventilation Mid Fan Speed	ON	Effective Mid <sup>1(e)</sup>	Effective Mid <sup>1(e)</sup>	Open	Design Mid	0	0	In Control	Min	OFF	0	Test	Maximum Heat
Ventilation High Fan Speed	ON	100	100	Open	Design Max	0	0	In Control	Min	OFF	0	Test	Maximum Heat
Cool 1	ON	Min for Capacity	100	Open	Min	1	0	In Control	Min	ON	0	Test	Maximum Heat
Cool 2	ON	Min for Capacity	100	Open	Min	2	0	In Control	Min	ON	0	Test	Maximum Heat
Cool 3	ON	Min for Capacity	100	Open	Min	3	0	In Control	Min	ON	0	Test	Maximum Heat
Cool 4	ON	Min for Capacity	100	Open	Min	4	0	In Control	Min	ON	0	Test	Maximum Heat
Cool 5	ON	Min for Capacity	100	Open	Min	5	0	In Control	Min	ON	0	Test	Maximum Heat
Reheat	ON	Min for Capacity	100	Open	Min	5	0	In Control	Min	OFF	50	Test	Maximum Heat
Heat 1	ON	Min for Capacity	100	Open	Min	0	1	In Control	Min	OFF	0	Test	Maximum Heat
Heat 2	ON	100	100	Open	Min	0	2	In Control	Min	OFF	0	Test	Maximum Heat
Defrost	ON	100	100	Open	Min	0	0	In Control	Min	ON	0	Test	Maximum Heat
Emergency Heat	ON	100	100	Open	Min	0	4	In Control	Min	OFF	0	Test	Maximum Heat



**Table 16. Service test state request (continued)**

Device Request / Service Test Step	Supply fan On/Off request	Supply fan speed request (VVZT, CVZT)	Supply fan speed request (VVDA) (a)	VAV box relay request (VVDA)	Outdoor air damper position request	Compressor cool stage request	Aux heat stage request	Relief fan On/Off request	Relief damper position request	Reheat pumpout solenoid On/Off request (b)	Reheat valve 1 request (c)	Heat cool mode status (VVZT, CVZT)	Heat cool mode status (VVDA) (d)
Open Reheat Valve	OFF	0	0	Open	0	0	0	OFF	0	OFF	85 <sup>(f)</sup>	Test	Maximum Heat
Close Reheat Valve	OFF	0	0	Open	0	0	0	OFF	0	OFF	0	Test	Maximum Heat

(a) For VVDA units, Supply Fan Speed Request shall not be 100 before VAV boxes full open. If VAV box stroke timer has not been expired, set fan speed to Min to avoid high duct static pressure trip.

(b) Reheat Pumpout Solenoid On/Off Request shall be ON whenever compressor cool or heat stage request is greater than 0, except during the "Reheat" step.

(c) The value of Reheat Valve 2 Request will always be inverse of Reheat Valve 1 Request.

(d) For VVDA units, Heat Cool Mode Status shall be set to Maximum Heat to coordinate VAV Box Relay, when any service test step activated

(e) Supply Fan Speed Request "Effective Mid" equals to ( Effective Maximum Fan Speed + Effective Minimum Fan Speed ) / 2.

(f) Reheat Valve 1 Request is set to 85% in "Open Reheat Valve 1" step, because 85% is the max operating range during normal operation.

## Verifying Proper Fan Rotation

### **⚠ WARNING**

#### **Rotating Components!**

Failure to disconnect power before servicing could result in rotating components cutting and slashing technician which could result in death or serious injury.

Disconnect all electric power, including remote disconnects before servicing. Follow proper lockout/tagout procedures to ensure the power can not be inadvertently energized.

Using as a reference, momentarily jump across the test terminals to start the Minimum Ventilation Test.

The Exhaust Fan will start anytime the economizer damper position is equal to or greater than the exhaust fan setpoint.

The economizer will drive to the minimum position setpoint, exhaust fans may start at random, and the supply fan will start.

Once the supply fan has started, check for proper rotation. The direction of rotation is indicated by an arrow on the fan housing.

If the fan is rotating backwards, open the main power disconnect switch upstream of the unit terminal block or the unit factory mounted disconnect switch.

### **⚠ WARNING**

#### **Hazardous Voltage!**

Failure to disconnect power before servicing could result in death or serious injury.

Disconnect all electric power, including remote disconnects before servicing. Follow proper lockout/tagout procedures to ensure the power can not be inadvertently energized. Verify that no power is present with a voltmeter.

Confirm that brown, orange, and yellow wire are on L1, L2, L3 for the supply fan power harnesses. Make necessary interchange if they are not.

**Note:** Interchanging "Load" side power wires at the supply fan contactor will only affect the Fan Rotation. Ensure that the voltage phase sequence at the main unit terminal block or the unit mounted disconnect switch is ABC as outlined in "Electrical Phasing," p. 46.

## Verifying Proper Air Flow (CFM)

1. All systems - Set the minimum position setting for the economizer to 0° using the setpoint potentiometer located on the Economizer Actuator in the return section with the supply fan "On" and rotating in the proper direction:

VFD's - With the O/A dampers fully closed, read the amperage displayed on the VFD screen and compare it to the motor nameplate.

**Note:** On VAV applications, the VFD will be under control of the discharge Static Pressure setpoint for the first six minutes of this test mode. Verify that the VFD output is at 60 Hz before measuring the fan motor amps.

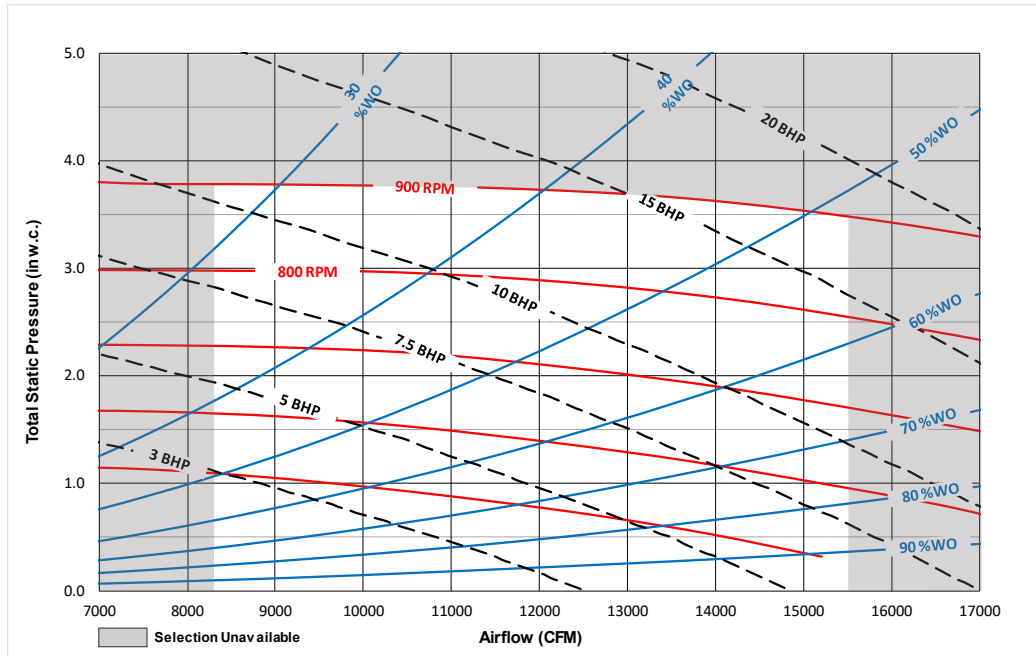
If the actual amperage exceeds the nameplate value, static pressure is less than design and air flow is too high. If the actual amperage is below the nameplate value, static pressure is greater than design and air flow is too low.

2. To determine the actual CFM (within + 5%), plot the fan's operating RPM and the theoretical BHP onto the appropriate Fan Performance Curve.

Theoretical BHP Formula:  $[(\text{Actual Motor Amps})/(\text{Motor Nameplate Amps})] \times 100$

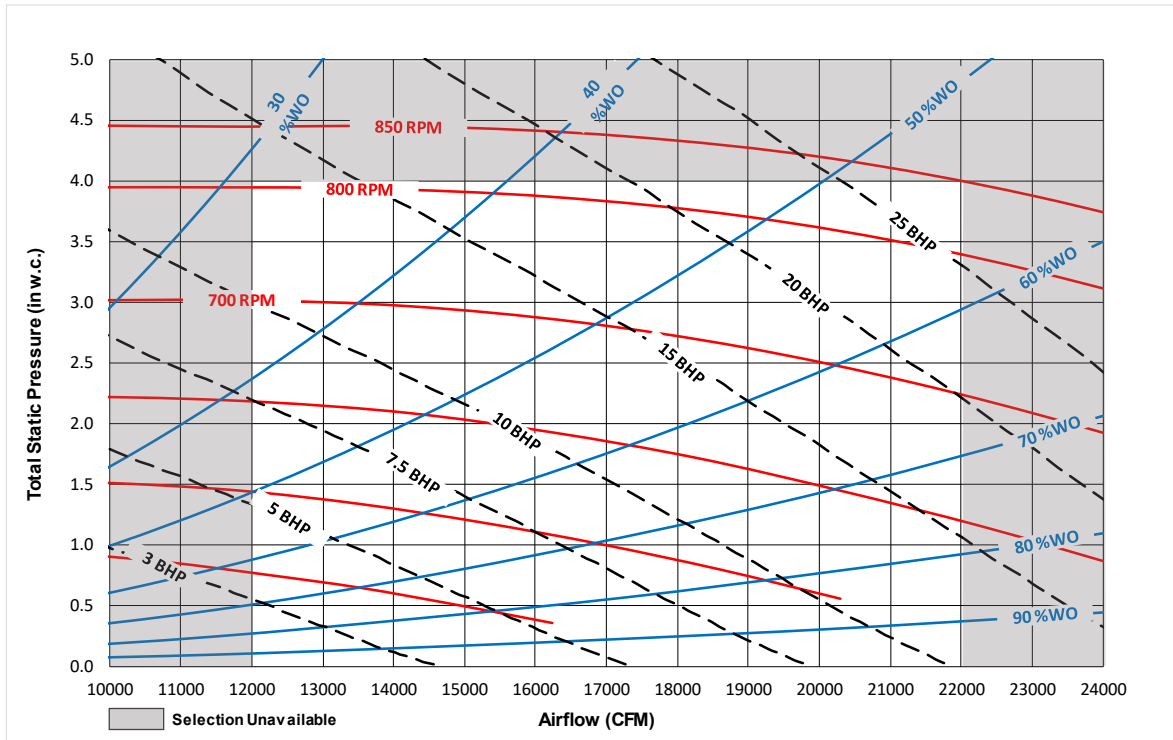
Where the two points intersect, read straight down to the CFM line. Use the fan curves to select a new fan drive if the CFM is not within specifications.

**Figure 37. Rooftop supply fan performance - 27.5, 30, and 35 tons - forward curved**



**Notes:**

- Supply fan performance curve includes internal resistance of rooftop. For total static pressure determination, system external static must be added to appropriate component (evaporator coil, filters) static pressure drops.
- Static pressure drops from the supply fan to the space (optional heat + curb + supply ESP) cannot exceed 3.0 in w.c.
- Curve can show combined operating min/max for multiple tonnages. Refer to general data for appropriate operating parameters such as motor horsepower and airflow ranges.
- Shaded areas represent unavailable selections. Contact your local Trane representative for more information on selections in these shaded regions.
- Max RPM is indicated on curve and RPM values are in increments of 100RPM unless otherwise shown.
- Catalog curves represent fan data corrected to the following standard conditions: 70°F dry bulb temperature, barometric pressure of 14.696 psia, and an air density of 0.075 lb/ft<sup>3</sup>. Utilize Trane Select Assist™ to generate fan curves for unit-specific operating temperatures and elevations.

**Figure 38. Rooftop supply fan performance - 40 and 50 tons - forward curved**

**Notes:**

- Supply fan performance curve includes internal resistance of rooftop. For total static pressure determination, system external static must be added to appropriate component (evaporator coil, filters) static pressure drops.
- Static pressure drops from the supply fan to the space (optional heat + curb + supply ESP) cannot exceed 3.0 in w.c.
- Curve can show combined operating min/max for multiple tonnages. Refer to general data for appropriate operating parameters such as motor horsepower and airflow ranges.
- Shaded areas represent unavailable selections. Contact your local Trane representative for more information on selections in these shaded regions.
- Max RPM is indicated on curve and RPM values are in increments of 100RPM unless otherwise shown.
- Catalog curves represent fan data corrected to the following standard conditions: 70°F dry bulb temperature, barometric pressure of 14.696 psia, and an air density of 0.075 lb/ft<sup>3</sup>. Utilize Trane Select Assist™ to generate fan curves for unit-specific operating temperatures and elevations.

**Table 17. Supply air fan drive selections — 60 Hz**

Nominal Tons	7.5 HP		10 HP		15 HP		20 HP		25 HP	
	RPM	Drive No.	RPM	Drive No.	RPM	Drive No.	RPM	Drive No.	RPM	Drive No.
27.5	550	A								
	600	B								
	650	C								
			700	D						
			750	E						
			800	G	800	G				
30	550	A								
	600	B								
	650	C								
			700	D						
			750	E	750	E				
					800	G				
35	600	B								
			650	C						
			700	D	700	D				
			750	E	750	E				
					800	G				
					850	R	850	R		
40										
			500	H						
			525	J						
			575	K						
					625	L				
					675	M				
50										
			525	J						
			575	K						
					625	L				
					675	M	675	M		
					725	N	725	N	725	N
						775	P	775	P	
								825	Q	



Startup

Table 18. Component static pressure drops (in. W.G.) — 60Hz

Nom. Tons	CFM Std Air	Heating System				Standard Efficiency ID Coil		High Efficiency ID Coil		Filters				Econo-mizer	Hot Gas Reheat Coil
		Gas Heat		Electric Heat		Coil		Coil		Throw-away	MERV 8 High Eff		MERV 14 High Eff		
		Low	High	1 Element	2 Elements	Dry	Wet	Dry	Wet	2"	2"	4"	4"		
27.5	8000	0.26	0.23	0.05	0.06	0.16	0.25	0.20	0.31	0.07	0.10	0.09	0.24	0.04	0.08
	9000	0.34	0.25	0.07	0.07	0.19	0.29	0.24	0.36	0.08	0.11	0.11	0.28	0.04	0.10
	10000	0.42	0.26	0.08	0.09	0.23	0.35	0.29	0.43	0.09	0.12	0.12	0.32	0.05	0.12
	11000	0.50	0.28	0.10	0.11	0.27	0.40	0.34	0.49	0.11	0.13	0.14	0.37	0.06	0.14
	12000	0.60	0.29	0.12	0.13	0.31	0.45	0.39	0.56	0.12	0.15	0.16	0.41	0.07	0.17
30	9000	0.34	0.25	0.07	0.07	0.19	0.29	0.24	0.36	0.08	0.11	0.11	0.28	0.04	0.10
	10000	0.42	0.26	0.08	0.09	0.23	0.35	0.29	0.43	0.09	0.12	0.12	0.32	0.05	0.12
	11000	0.50	0.28	0.10	0.11	0.27	0.40	0.34	0.49	0.11	0.13	0.14	0.37	0.06	0.14
	12000	0.60	0.29	0.12	0.13	0.31	0.45	0.39	0.56	0.12	0.15	0.16	0.41	0.07	0.17
	13000	0.71	0.31	0.14	0.15	0.36	0.51	0.44	0.63	0.14	0.16	0.18	0.46	0.09	0.20
35	10500	0.46	0.27	0.09	0.10	0.25	0.37	0.31	0.46	0.10	0.13	0.13	0.35	0.06	0.13
	11500	0.55	0.29	0.11	0.12	0.29	0.42	0.36	0.53	0.11	0.14	0.15	0.39	0.07	0.16
	12500	0.65	0.30	0.13	0.14	0.33	0.48	0.41	0.60	0.13	0.16	0.17	0.44	0.08	0.18
	13500	0.76	0.32	0.15	0.16	0.38	0.53	0.48	0.66	0.15	0.17	0.19	0.49	0.10	0.22
	14500	0.88	0.33	0.18	0.19	0.42	0.59	0.53	0.74	0.16	0.19	0.21	0.54	0.11	0.25
15400	1.00	0.35	0.20	0.21	0.46	0.64	0.57	0.80	0.18	0.21	0.23	0.59	0.12	0.28	
40	12000	0.27	0.49	0.08	0.13	0.30	0.45	0.30	0.45	0.14	0.14	0.14	0.38	0.07	0.06
	13000	0.30	0.54	0.10	0.15	0.35	0.51	0.35	0.51	0.15	0.15	0.16	0.43	0.08	0.07
	14000	0.33	0.59	0.11	0.18	0.39	0.58	0.39	0.58	0.17	0.17	0.18	0.47	0.09	0.08
	15000	0.37	0.64	0.13	0.20	0.44	0.63	0.44	0.63	0.18	0.18	0.20	0.52	0.10	0.09
	16000	0.40	0.70	0.15	0.23	0.49	0.69	0.49	0.69	0.20	0.20	0.22	0.57	0.11	0.10
17000	0.43	0.75	0.17	0.26	0.54	0.75	0.54	0.75	0.22	0.22	0.25	0.62	0.12	0.11	
50	15000	0.37	0.64	0.13	0.20	0.44	0.63	0.44	0.63	0.18	0.18	0.20	0.52	0.10	0.09
	16000	0.40	0.70	0.15	0.23	0.49	0.69	0.49	0.69	0.20	0.20	0.22	0.57	0.11	0.10
	17000	0.43	0.75	0.17	0.26	0.54	0.75	0.54	0.75	0.22	0.22	0.25	0.62	0.12	0.11
	18000	0.47	0.80	0.19	0.29	0.59	0.82	0.59	0.82	0.24	0.24	0.27	0.67	0.14	0.13
	19000	0.50	0.85	0.21	0.32	0.65	0.89	0.65	0.89	0.26	0.26	0.30	0.73	0.16	0.14
	20000	0.54	0.91	0.23	0.36	0.71	0.96	0.71	0.96	0.29	0.29	0.33	0.79	0.18	0.16
	21000	0.58	0.96	0.25	0.39	0.76	1.03	0.76	1.03	0.31	0.31	0.36	0.85	0.21	0.18
22000	0.62	1.01	0.27	0.42	0.82	1.09	0.82	1.09	0.34	0.34	0.39	0.91	0.24	0.20	

Note: Static pressure drops of accessory components must be added to external static pressure to enter fan selection tables.

Table 19. Component static pressure drops in. W.G (I-P) — 50Hz

Nom. Tons	CFM Std Air	Heating System				Standard Efficiency ID Coil		High Efficiency ID Coil		Filters				Econo-mizer	Hot Gas Reheat Coil
		Gas Heat		Electric Heat		Coil		Coil		Throw-away	MERV 8 High Eff		MERV 14 High Eff		
		Low	High	1 Element	2 Elements	Dry	Wet	Dry	Wet	2"	2"	4"	4"		
23 (80)	6670	—	—	0.04	0.05	0.12	0.19	0.15	0.24	0.05	0.08	0.07	0.19	0.03	0.05
	7500	—	—	0.06	0.06	0.15	0.23	0.18	0.29	0.06	0.09	0.08	0.22	0.04	0.07
	8330	—	—	0.07	0.08	0.17	0.27	0.21	0.33	0.07	0.10	0.10	0.26	0.05	0.08
	9170	—	—	0.08	0.09	0.20	0.31	0.25	0.38	0.08	0.11	0.11	0.29	0.06	0.10
	10000	—	—	0.10	0.11	0.23	0.35	0.29	0.43	0.09	0.12	0.12	0.32	0.07	0.12
25 (88)	7500	—	—	0.06	0.06	0.15	0.23	0.18	0.29	0.06	0.09	0.08	0.22	0.04	0.07
	8330	—	—	0.07	0.08	0.17	0.27	0.21	0.33	0.07	0.10	0.10	0.26	0.05	0.08
	9170	—	—	0.08	0.09	0.20	0.31	0.25	0.38	0.08	0.11	0.11	0.29	0.06	0.10
	10000	—	—	0.10	0.11	0.23	0.35	0.29	0.43	0.09	0.12	0.12	0.32	0.07	0.12

**Table 19. Component static pressure drops in. W.G (I-P) — 50Hz (continued)**

Nom. Tons	CFM Std Air	Heating System				Standard Efficiency ID Coil		High Efficiency ID Coil		Filters				Econo-mizer	Hot Gas Reheat Coil
		Gas Heat		Electric Heat		Dry	Wet	Dry	Wet	Throw-away	MERV 8 High Eff		MERV 14 High Eff		
		Low	High	1 Element	2 Elements						2"	2"			
29 (103)	8750	–	–	0.08	0.08	0.18	0.28	0.23	0.35	0.08	0.11	0.10	0.27	0.05	0.09
	9580	–	–	0.09	0.10	0.21	0.32	0.26	0.40	0.09	0.12	0.11	0.31	0.07	0.11
	11200	–	–	0.13	0.14	0.28	0.41	0.35	0.51	0.11	0.14	0.14	0.38	0.08	0.15
	12100	–	–	0.15	0.16	0.31	0.46	0.39	0.58	0.12	0.15	0.16	0.42	0.09	0.17
	12800	–	–	0.16	0.18	0.34	0.50	0.42	0.62	0.13	0.16	0.17	0.45	0.10	0.19
33 (118)	10000	–	–	0.07	0.11	0.23	0.35	0.23	0.35	0.08	0.11	0.11	0.30	0.07	0.04
	10800	–	–	0.08	0.13	0.25	0.39	0.25	0.39	0.09	0.12	0.12	0.33	0.08	0.05
	11700	–	–	0.10	0.15	0.29	0.44	0.29	0.44	0.11	0.13	0.14	0.37	0.09	0.05
	12500	–	–	0.11	0.17	0.33	0.49	0.33	0.49	0.12	0.14	0.15	0.40	0.10	0.06
	13300	–	–	0.12	0.19	0.36	0.53	0.36	0.53	0.13	0.16	0.17	0.44	0.11	0.07
14200	–	–	0.14	0.22	0.40	0.58	0.40	0.58	0.14	0.17	0.18	0.48	0.12	0.08	
42 (146)	12500	–	–	0.11	0.17	0.33	0.48	0.33	0.48	0.12	0.14	0.15	0.40	0.10	0.06
	13300	–	–	0.12	0.19	0.36	0.53	0.36	0.53	0.13	0.16	0.17	0.44	0.11	0.07
	14200	–	–	0.16	0.24	0.40	0.58	0.40	0.58	0.14	0.17	0.18	0.48	0.12	0.08
	15800	–	–	0.18	0.27	0.48	0.68	0.48	0.68	0.17	0.20	0.22	0.56	0.14	0.10
	16700	–	–	0.20	0.30	0.53	0.74	0.53	0.74	0.18	0.21	0.24	0.61	0.16	0.11
18300	–	–	0.23	0.35	0.61	0.84	0.61	0.84	0.21	0.25	0.28	0.69	0.18	0.13	

Note: Static pressure drops of accessory components must be added to external static pressure to enter fan performance tables.

**Table 20. Supply air fan drive selections—50 Hz**

Nominal Tons (kW)	7.5 HP (5.6 kW)		10 HP (7.5 kW)		15 HP (10 kW)		20 HP (15 kW)	
	RPM	Drive No.	RPM	Drive No.	RPM	Drive No.	RPM	Drive No.
23 (80)	498	A						
	500	B						
	541	C						
			583	D				
			625	E				
25 (88)	458	A						
	500	B						
	541	C						
			583	D				
			625	E				
				664	G			
29 (103)	500	B						
			541	C				
			583	D				
			625	E				
					664	G		
				708	R			



## Startup

**Table 20. Supply air fan drive selections—50 Hz (continued)**

Nominal Tons (kW)	7.5 HP (5.6 kW)		10 HP (7.5 kW)		15 HP (10 kW)		20 HP (15 kW)	
	RPM	Drive No.	RPM	Drive No.	RPM	Drive No.	RPM	Drive No.
33 (108)			417	H				
			437	J				
			479	K				
					521	L		
					562	M		
					604	N		
42 (146)			437	J				
			479	K				
					521	L		
					562	M		
					604	N	604	N
							646	P

### Exhaust Fan Operation

To start the optional power exhaust fans, use the economizer test procedures in - to drive the economizer dampers to the open position. The exhaust fans will start when the damper position is equal to or greater than the exhaust fan setpoint. If optional power exhaust is selected, an access door must be field-installed on the horizontal return ductwork to provide access to exhaust fan motors.

The exhaust fan will start anytime the economizer damper position is equal to or greater than the exhaust fan setpoint.

#### **⚠ WARNING**

##### **Rotating Components!**

**Failure to disconnect power before servicing could result in rotating components cutting and slashing technician which could result in death or serious injury.**

**Disconnect all electric power, including remote disconnects before servicing. Follow proper lockout/tagout procedures to ensure the power can not be inadvertently energized.**

Verify that the fans are operating properly and the CFM is within the job specifications. Refer to power exhaust fan performance tables beginning with for the exhaust fan performance characteristics.

Available power adjustments:

- The relief fan comes on based on the Relief Enable Position setpoint that is user adjustable within the Symbio 700 user interface or mobile app. The relief fan will energize anytime the outdoor air damper is equal to or greater than the value of this setpoint. The setpoint default is 25%.
- Physical damper blade stops limit the amount of exhaust airflow by limiting the maximum opening of the

damper blades. These stops (sliding brackets secured with wing-nuts) are present under the rain hood on the non-modulating power exhaust option. There is one stop on each side of each damper. The practical range of blade position control is between 1.5" and 4.0" blade opening. The damper is wide-open at 4.0". The stops on each side of a damper must be in the same position, such that the damper blade connecting member contacts the stops at the same time.

- If configured for Fresh Air Damper Tracking, the modulating power exhaust actuator tracks the position of the economizer damper actuator such that the power exhaust dampers proportionally follow or track the fresh air damper position.
- When the Statitrac option is selected, the exhaust actuator will operate independently of the economizer in order to relieve positive building pressure. If a Space Pressure Transducer failure occurs, the unit will revert back to fresh air tracking control.
- The proportional offset between the dampers is adjustable. With direct-drive ultra-low-leak exhaust options, actuator stroke can be adjusted as described in "Economizer (O/A) Dampers," p. 59. The stroke limit can be set between 33% and 100% of full stroke.

**Note:** *The barometric damper continues to function as a pressure relief damper up to the maximum stop position.*

*To adjust the damper blade stops, refer to figure Figure 39, p. 58 to Figure 42, p. 59.*

If the fan speed needs to be changed from the current operating speed, refer to the unit wiring diagram and the XTB1 and XTB2 terminal strip located in the economizer section.



**Table 21. Power exhaust fan performance—27.5-35 ton—60 Hz**

	Power Exhaust Selection			
	50%		100%	
	Damper Open Position			
	min	max	min	max
Return Duct Static (in. wc)	CFM			
0.0	3812	6866	7624	13742
0.1	3497	5296	6995	10591
0.2	3190	4458	6325	9000
0.3	2884	3812	5768	7635
0.4	2621	3359	5241	6719
0.5	2342	2885	4683	5771

**Note:** These values are the minimum and maximum positions for non-tracking power exhaust. Fresh air tracking and Statitrac options can fully close the exhaust dampers in their operation, and are thus able to reach lower airflows. Statitrac requires 100% power exhaust.

**Table 22. Power exhaust fan performance—40-50—60 Hz**

	Power Exhaust Selection			
	50%		100%	
	Damper Open Position			
	min	max	min	max
Return Duct Static (in. wc)	CFM			
0.0	4854	8035	9708	16069
0.1	4575	7410	9151	14820
0.2	4262	6450	8552	13496
0.3	4011	6027	8021	12054
0.4	3718	5526	7436	11051
0.5	3467	5186	6933	10373

**Note:** These values are the minimum and maximum positions for non-tracking power exhaust. Fresh air tracking and Statitrac options can fully close the exhaust dampers in their operation, and are thus able to reach lower airflows. Statitrac requires 100% power exhaust.

**Table 23. Power exhaust fan performance—22.9-29.2 tons—50 Hz**

	Power Exhaust Selection			
	50%		100%	
	Damper Open Position			
	min	max	min	max
Return Duct Static (Pa)	L/s			
0.0	1499	2701	2999	5405
24.9	1375	2083	2751	4166
49.8	1255	1753	2488	3540
74.7	1134	1499	2269	3003

**Table 23. Power exhaust fan performance—22.9-29.2 tons—50 Hz (continued)**

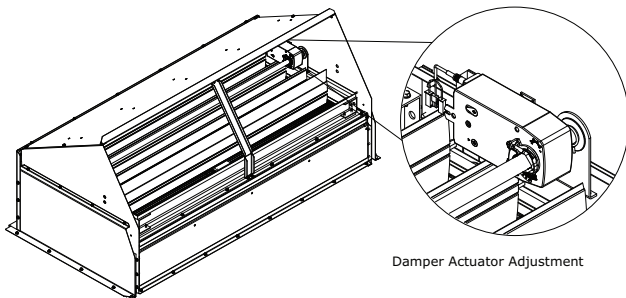
	Power Exhaust Selection			
	50%		100%	
	Damper Open Position			
	min	max	min	max
Return Duct Static (Pa)	L/s			
99.6	1031	1321	2061	2643
124.5	921	1135	1842	2270

**Table 24. Power exhaust fan performance—33.3-41.7 tons—50 Hz**

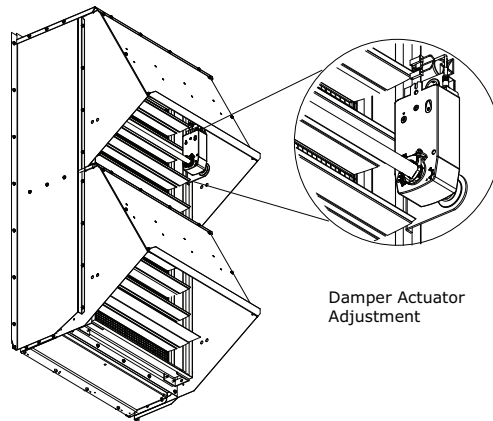
	Power Exhaust Selection			
	50%		100%	
	Damper Open Position			
	min	max	min	max
Return Duct Static (Pa)	L/s			
0.0	1909	3160	3818	6321
24.9	1800	2915	3599	5829
49.8	1676	2537	3364	5308
74.7	1577	2371	3155	4741
99.6	1462	2173	2925	4347
124.5	1364	2040	2727	4080

**Note:** These values are the minimum and maximum positions for non-tracking power exhaust. Fresh air tracking and Statitrac options can fully close the exhaust dampers in their operation, and are thus able to reach lower airflows. Statitrac requires 100% power exhaust.

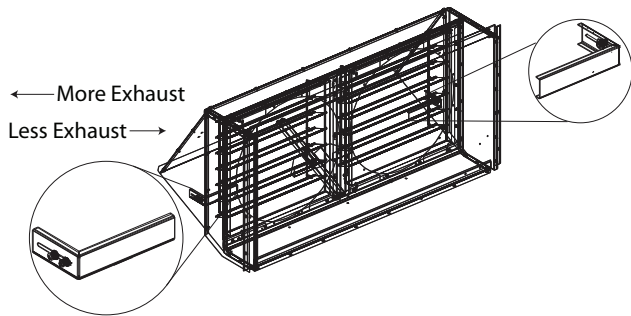
**Figure 39. (Upflow) Exhaust damper actuator adjustment**



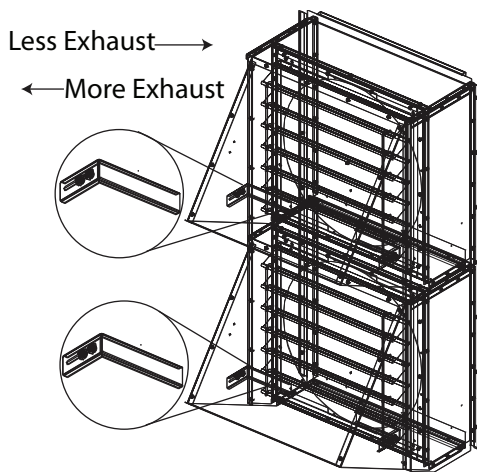
**Figure 40. (Horizontal) Exhaust damper actuator adjustment**



**Figure 41. (Upflow) Exhaust maximum damper position**



**Figure 42. (Horizontal) Exhaust maximum damper position**



## Economizer Damper Adjustment

### Economizer (O/A) Dampers

Arbitrarily adjusting the outside air dampers to open fully when the return air dampers are fully closed can overload the supply fan motor or deliver higher CFM to the space than designed. This causes higher operating duct static

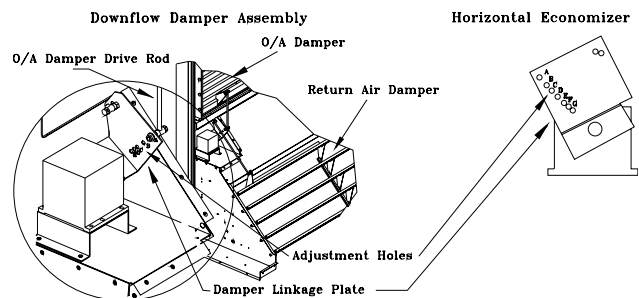
pressures and over pressurization of the space when the unit is operating in the “economizer” mode.

The purpose of adjusting the amount of O/A damper travel is to maintain a balance or equal pressure between the O/A dampers and the pressure drop of the return air system. For models with standard or low-leak economizers, the O/A and R/A damper linkage is attached to a plate with a series of holes that allows the installer or operator to modify the O/A damper travel to compensate for various RA duct losses. Figure 43, p. 59 illustrates the damper assembly and through list the various damper positions based on the air flow (CFM) and the return duct losses (static pressure) for Downflow and Horizontal units.

To adjust the O/A damper for the correct pressure drop:

1. Measure the return duct static pressure.
2. Enter the calculated CFM from the previous section “Verifying Proper Airflow” to obtain the return air damper pressure drop.
3. Add the measured return duct static pressure and the return air damper pressure drop together to obtain the Total Return Static Pressure. Apply this calculation and the calculated CFM to the appropriate through .
4. Set the drive rod swivel to the appropriate hole according to through . The units are shipped using hole “A” with no reference to any specific operating condition.

**Figure 43. Economizer (O/A) damper assembly**



**Table 25. 27.5 - 35 Ton downflow economizer (O/A) damper static pressure setup**

System Design CFM	Return Air Duct Static + Return Air Damper Static (Inches of Water)						
	0.2	0.4	0.6	0.8	1	1.2	1.4
Drive Rod Position							
8000	B	E	E	E	E	E	E
8500	B	D	E	E	E	E	E
9500	A	C	E	E	E	E	E
10000	A	C	D	E	E	E	E
10500	A	C	D	E	E	E	E
11000	A	B	D	D	E	E	E
11500	A	B	C	D	E	E	E



**Startup**

**Table 25. 27.5 - 35 Ton downflow economizer (O/A) damper static pressure setup (continued)**

System Design CFM	Return Air Duct Static + Return Air Damper Static (Inches of Water)						
	0.2	0.4	0.6	0.8	1	1.2	1.4
	Drive Rod Position						
12000	A	A	C	D	E	E	E
12500	A	A	C	D	D	E	E
13000	A	A	B	B	C	D	E
13500	A	A	B	B	C	D	E
14000	A	A	A	B	C	D	E
14500	A	A	A	B	C	D	D
15000	A	A	A	A	B	C	D

**Table 26. 27.5 - 35 Ton horizontal economizer (O/A) damper static pressure setup**

System Design CFM	Return Air Duct Static + Return Air Damper Static (Inches of Water)						
	0.2	0.4	0.6	0.8	1	1.2	1.4
	Drive Rod Position						
8000	A	F	G	G	G	G	G
8500	A	F	G	G	G	G	G
9000	A	E	G	G	G	G	G
9500	A	E	F	G	G	G	G
10000	A	D	E	G	G	G	G
11000	A	D	E	F	G	G	G
11500	A	B	E	F	G	G	G
12000	A	A	D	F	G	G	G
12500	A	A	D	E	F	G	G
13000	A	A	D	E	F	G	G
13500	A	A	C	E	F	F	G
14000	A	A	C	D	E	F	G
14500	A	A	B	D	E	F	F
15000	A	A	B	D	E	F	F
15500	A	A	B	D	E	E	F

**Table 27. 40 - 50 Ton downflow economizer (O/A) damper static pressure setup**

System Design CFM	Return Air Duct Static + Return Air Damper Static (Inches of Water)						
	0.2	0.4	0.6	0.8	1	1.2	1.4
	Drive Rod Position						
12000	A	A	C	D	E	E	E
12500	A	A	C	D	D	E	E
13000	A	A	B	C	D	E	E
13500	A	A	B	C	D	D	E
14000	A	A	B	C	C	D	E
14500	A	A	B	B	C	D	D

**Table 27. 40 - 50 Ton downflow economizer (O/A) damper static pressure setup (continued)**

System Design CFM	Return Air Duct Static + Return Air Damper Static (Inches of Water)						
	0.2	0.4	0.6	0.8	1	1.2	1.4
	Drive Rod Position						
15000	A	A	A	B	C	D	D
15500	A	A	A	B	C	D	D
16000	A	A	A	B	C	C	D
16500	A	A	A	B	B	C	D
17000	A	A	A	B	B	C	C
17500	A	A	A	A	B	C	C
18000	A	A	A	A	B	C	C
18500	A	A	A	A	B	B	C
19000	A	A	A	A	B	B	C
19500	A	A	A	A	B	B	B
20000	A	A	A	A	A	B	B
20500	A	A	A	A	A	B	B
21000	A	A	A	A	A	B	B
21500	A	A	A	A	A	A	B
22000	A	A	A	A	A	A	B

**Table 28. 40 - 50 Ton horizontal economizer (O/A) damper static pressure setup**

System Design CFM	Return Air Duct Static + Return Air Damper Static (Inches of Water)						
	0.2	0.4	0.6	0.8	1	1.2	1.4
	Drive Rod Position						
12000	A	B	E	F	G	G	G
12500	A	B	D	E	F	G	G
13000	A	A	D	E	F	G	G
13500	A	A	D	E	F	G	G
14000	A	A	C	E	F	F	G
14500	A	A	C	D	E	F	F
15000	A	A	B	D	E	F	F
15500	A	A	B	D	E	E	F
16000	A	A	A	C	D	E	F
16500	A	A	A	C	D	E	F
17000	A	A	A	B	D	E	E
17500	A	A	A	B	D	E	E
18000	A	A	A	B	C	D	E
18500	A	A	A	A	C	D	E
19000	A	A	A	A	B	D	E
19500	A	A	A	A	B	C	E
20000	A	A	A	A	B	C	D
20500	A	A	A	A	A	C	D

Table 28. 40 - 50 Ton horizontal economizer (O/A) damper static pressure setup (continued)

System Design CFM	Return Air Duct Static + Return Air Damper Static (Inches of Water)						
	0.2	0.4	0.6	0.8	1	1.2	1.4
	Drive Rod Position						
21000	A	A	A	A	A	B	D
21500	A	A	A	A	A	B	D
22000	A	A	A	A	A	A	B

### Models with Ultra-Low Leak Economizers

The installer can adjust the stroke of the direct drive actuator on the O/A damper to compensate for various R/A duct losses. Figure 45, p. 62 and Figure 46, p. 63 illustrate the damper & actuator assembly and through list the various O/A actuator limit positions based on the air flow (CFM) and the return duct losses (static pressure) for Downflow and Horizontal units. The actuator stroke limit can be adjusted between 33% and 100% of full stroke. To adjust the O/A damper for the correct pressure drop:

1. Measure the return duct static pressure.
2. Enter the calculated CFM from the previous section “,” to obtain the return air damper pressure drop.
3. Add the measured return duct static pressure and the return air damper pressure drop together to obtain the Total Return Static Pressure. Apply this calculation and the calculated CFM to the appropriate table. See through .
4. To set the actuator stroke limit:
  - a. Loosen the screw that secures the angle of rotation limiter on the actuator adjacent to the damper drive shaft clamp.
  - b. Move the limiter to the desired % open position and, making sure the limiter teeth are engaged, retighten the screw. (See Figure 44, p. 62).
5. After setting the end stop, the actuator needs to be cycled through its auto-adapt feature to re-scale the control range. With 24 VAC power applied to the actuator, turn the control signal reversing switch forward and back again two times. Within a few seconds, the actuator will cycle itself to the new limiter position and then back to zero. This process may take up to 5 minutes. The actuator will then be set to respond to the 2-10 VDC control signal to cycle within the new range of rotation set by the limiter. Verify that the control signal reversing switch is set back to its original default position - Y = 0 - same direction as spring return. (See Figure 47, p. 63).

Figure 44. Actuator stroke limit adjustment

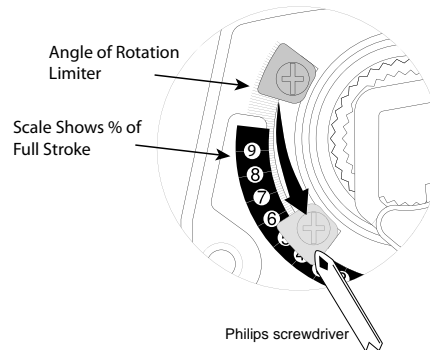
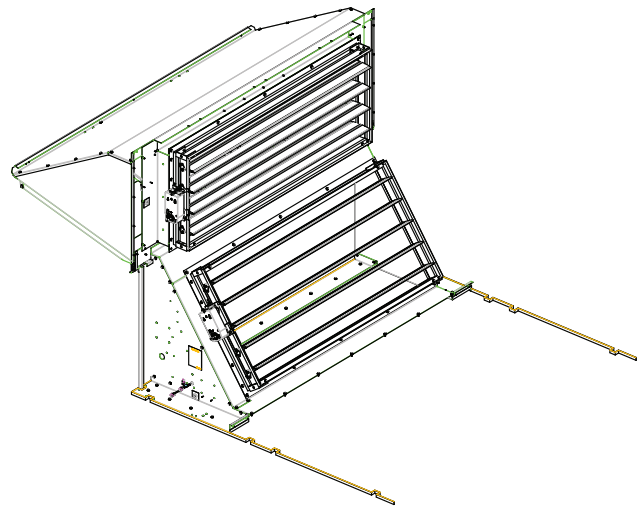
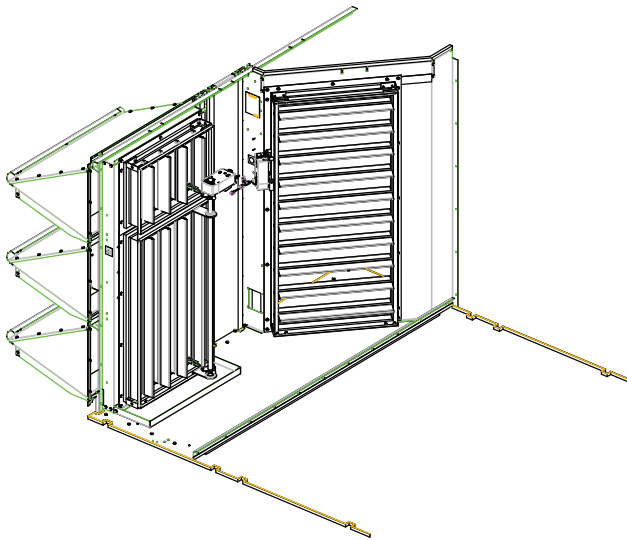


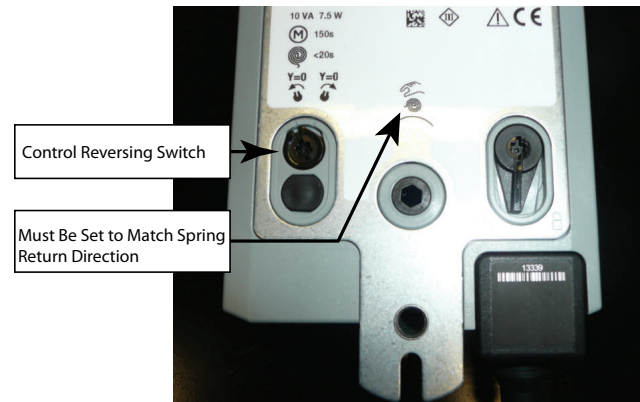
Figure 45. Actuator for OA damper - Downflow



**Figure 46. Actuator for OA damper - horizontal**



**Figure 47. Actuator auto-scaling feature details**



**Table 29. 27.5 - 35 Ton downflow economizer (O/A) - ultra-low leak economizer**

System Design CFM	Return Air Duct Static + Return Air Damper Static (Inches of Water)						
	0.2	0.4	0.6	0.8	1	1.2	1.4
	Stroke limit setting % on OA damper actuator						
8000	75	55	55	55	55	55	55
8500	75	60	55	55	55	55	55
9500	100	65	55	55	55	55	55
10000	100	65	60	55	55	55	55
10500	100	65	60	60	55	55	55
11000	100	75	65	60	55	55	55
11500	100	75	65	60	55	55	55
12000	100	100	65	60	55	55	55
12500	100	100	65	60	60	55	55
13000	100	100	75	75	65	60	55
13500	100	100	75	65	60	60	55
14000	100	100	75	65	65	60	55
14500	100	100	75	75	65	60	60
15000	100	100	100	75	65	60	60
15500	100	100	100	75	65	60	60

**Table 30. 27.5 - 35 Ton horizontal economizer (O/A) - ultra-low-leak economizer**

System Design CFM	Return Air Duct Static + Return Air Damper Static (Inches of Water)						
	0.2	0.4	0.6	0.8	1	1.2	1.4
	Stroke limit setting % on OA damper actuator						
8000	100	45	40	40	40	40	40
8500	100	45	40	40	40	40	40
9000	100	50	40	40	40	40	40

**Table 30. 27.5 - 35 Ton horizontal economizer (O/A) - ultra-low-leak economizer (continued)**

System Design CFM	Return Air Duct Static + Return Air Damper Static (Inches of Water)						
	0.2	0.4	0.6	0.8	1	1.2	1.4
	Stroke limit setting % on OA damper actuator						
9500	100	50	45	40	40	40	40
10000	100	60	50	40	40	40	40
11000	100	60	50	45	40	40	40
11500	100	80	50	45	40	40	40
12000	100	100	60	45	40	40	40
12500	100	100	60	50	45	40	40
13000	100	100	60	50	45	40	40
13500	100	100	70	50	45	45	40
14000	100	100	70	60	50	45	40
14500	100	100	80	60	50	45	45
15000	100	100	80	60	50	45	45
15500	100	100	80	60	50	50	45

**Table 31. 40 - 50 Ton downflow economizer (O/A) - ultra-low-leak economizer**

System Design CFM	Return Air Duct Static + Return Air Damper Static (Inches of Water)						
	0.2	0.4	0.6	0.8	1	1.2	1.4
	Stroke limit setting % on OA damper actuator						
12000	100	100	65	60	55	55	55
12500	100	100	65	60	60	55	55
13000	100	100	75	65	60	55	55
13500	100	100	75	65	60	60	55
14000	100	100	75	65	65	60	55
14500	100	100	75	75	65	60	60
15000	100	100	100	75	65	60	60
15500	100	100	100	75	65	60	60
16000	100	100	100	75	65	65	60
16500	100	100	100	75	75	65	60
17000	100	100	100	75	75	65	65
17500	100	100	100	100	75	65	65
18000	100	100	100	100	75	65	65
18500	100	100	100	100	75	75	65
19000	100	100	100	100	75	75	65
19500	100	100	100	100	75	75	75
20000	100	100	100	100	100	75	75
20500	100	100	100	100	100	75	75
21000	100	100	100	100	100	75	75
21500	100	100	100	100	100	100	75
22000	100	100	100	100	100	100	80



**Table 32. 40 - 50 Ton horizontal economizer (O/A) - ultra-low-leak economizer**

System Design CFM	Return Air Duct Static + Return Air Damper Static (Inches of Water)						
	0.2	0.4	0.6	0.8	1	1.2	1.4
	Stroke limit setting % on OA damper actuator						
12000	100	80	50	45	40	40	40
12500	100	80	60	50	45	40	40
13000	100	100	60	50	45	40	40
13500	100	100	60	50	45	40	40
14000	100	100	70	50	45	45	40
14500	100	100	70	60	50	45	45
15000	100	100	80	60	50	45	45
15500	100	100	80	60	50	50	45
16000	100	100	100	70	60	50	45
16500	100	100	100	70	60	50	45
17000	100	100	100	80	60	50	50
17500	100	100	100	80	60	50	50
18000	100	100	100	80	70	60	50
18500	100	100	100	100	70	60	50
19000	100	100	100	100	80	60	50
19500	100	100	100	100	80	70	50
20000	100	100	100	100	80	70	60
20500	100	100	100	100	100	80	60
21000	100	100	100	100	100	80	70
21500	100	100	100	100	100	100	70
22000	100	100	100	100	100	100	80

**Table 33. Low-leak economizer sensor values**

Temp °F	Resistance (K ohms)	Temp °F	Resistance (K ohms)	Temp °F	Resistance (K ohms)
40	26.097	54	17.847	68	12.435
41	25.383	55	17.382	69	12.126
42	24.690	56	16.930	70	11.827
43	24.018	57	16.491	71	11.535
44	23.367	58	16.066	72	11.252
45	22.736	59	15.654	73	10.977
46	22.132	60	15.253	74	10.709
47	21.530	61	14.864	75	10.448
48	20.953	62	14.486	76	10.194
49	20.396	63	14.119	77	9.949
50	19.854	64	13.762	78	9.710
51	19.330	65	13.416	79	9.477
52	18.821	66	13.078	80	9.250
53	18.327	67	12.752	81	9.030

## Manual Outside Air Damper

Units ordered with the 25% manual outside air option have two slidable dampers. By adjusting one or both, the desired amount of fresh air entering the system can be obtained.

To adjust the outside air damper;

1. Turn the “System” selection switch to the “Off” position and the “Fan” selection switch (if applicable) to the “Auto” position.
2. Close the disconnect switch or circuit protector switch that provides the supply power to the unit’s power terminal block or the unit factory mounted disconnect switch.

### **⚠ WARNING**

#### **Live Electrical Components!**

Failure to follow all electrical safety precautions when exposed to live electrical components could result in death or serious injury.

When it is necessary to work with live electrical components, have a qualified licensed electrician or other individual who has been properly trained in handling live electrical components perform these tasks.

**HIGH VOLTAGE IS PRESENT AT TERMINAL BLOCK**

**Table 34. Damper adjustment**

Damper Opening (in.)		Return Air Static Pressure - Inches w.c.							
Damper #1	Damper #2	-0.20	-0.40	-0.60	-0.80	-1.00	-1.20	-1.40	-1.60
2	0	430	590	725	840	950	1040	1120	740
4	0	780	1080	1330	1545	1730	1890	2035	2170
6	0	1185	1620	1990	2300	2575	2815	3030	3240
8	0	1530	2110	2600	3025	3390	3705	3985	4240
10	0	1930	2655	3270	3800	4250	4650	5005	5345
10	2	2295	3165	3910	4545	5095	5575	6010	6415
10	4	2660	3650	4510	5255	5905	6480	6995	7470
10	6	3010	4150	5130	5965	6690	7330	7900	8440
10	8	3345	4600	5680	6610	7410	8120	8765	9365
10	10	3690	5125	6350	7395	8295	9075	9775	10420

## Starting the Compressor

Optional service valves must be fully opened before startup (suction and discharge line).

### **NOTICE**

#### **Compressor Failure!**

Failure to follow instruction below could result in compressor failure.

Unit must be powered and crankcase heaters energized at least 8 hours **BEFORE** compressors are started.

### **HTB1 OR UNIT DISCONNECT SWITCH.**

3. Remove the mist eliminator retainer bracket and the mist eliminators from the fresh air hood.
4. Remove the five (5) screws in the top and bottom of each fresh air damper located inside the hood area.
5. Using the Symbio™ 700 user interface or the mobile app, choose a Service Test Step for ventilation.
6. With the supply fan “On” and rotating in the proper direction, measure the return duct static pressure.
7. Using [Table 34, p. 66](#), enter the desired amount of fresh air and the return air static pressure reading to obtain the proper damper opening dimension.
8. Loosen the adjustment screws on each side of the damper and slide it downward to the required opening.
9. Tighten the adjustment screws and re-install the mist eliminators and the mist eliminator retainer bracket.
10. Open the main power disconnect or the unit mounted disconnect switch to shut the unit off and to reset the Symbio™ controls.
11. Before closing the disconnect switch, ensure that the compressor discharge service valve(s) and suction service valve(s) are backseated.

### **⚠ WARNING**

#### **Live Electrical Components!**

Failure to follow all electrical safety precautions when exposed to live electrical components could result in death or serious injury.

When it is necessary to work with live electrical components, have a qualified licensed electrician or other individual who has been properly trained in handling live electrical components perform these tasks.

## Starting 27.5-50 Tons Standard and High Efficiency Units

Install a set of service gauges onto the suction and discharge service ports of the circuit. On the Symbio™ 700 user interface, enter service test mode in the desired cooling steps, cool 1 to cool 5.

After the compressor and the condenser fans have been operating for approximately 30 minutes, use [Figure 50, p. 68](#) through [Figure 65, p. 77](#) to determine the proper operating pressures for the circuit.

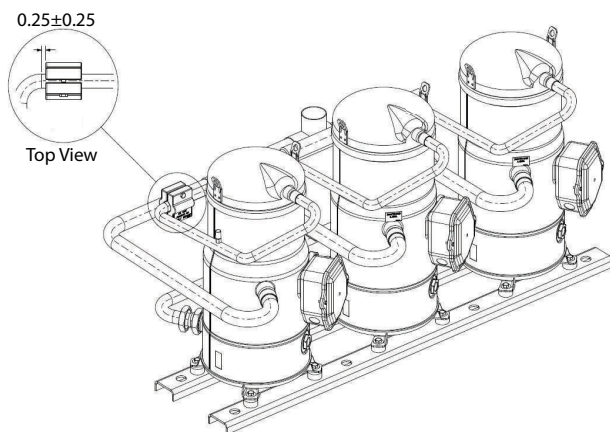
For subcooling guidelines, refer to “[Charging by Subcooling](#),” p. 78.

### Line Weights

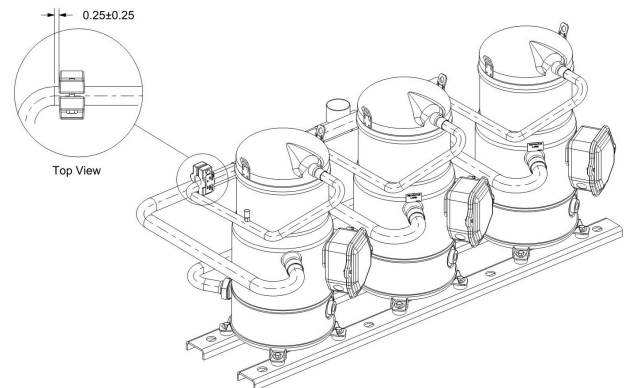
The standard and high efficiency units use line weights to dampen vibration. Do not remove, relocate, or over-torque these weights. The torque specification for the attaching bolts is 6 ft-lbs ± 1.0 ft-lb.

The locations of the line weights are shown in the following figures.

**Figure 48. Line weight location TE, YC, TC\*275–500**



**Figure 49. Line weight location TE, YC, TC\*480**



### Compressor Oil

Once all of the compressors have been started, verify that the oil level is visible through the sight glass or above the sight glass. Use appropriate lighting (flash light) to verify the presence of oil. A tandem manifold set may have different oil heights, but still must be visible in the sight glass or above the sight glass.

After shutting the compressors off, check the oil’s appearance. Discoloration of the oil indicates that an abnormal condition has occurred. If the oil is dark, overheating may have occurred. Potential causes of overheating: compressor is operating at extremely high condensing temperatures; high superheat; a compressor mechanical failure; or, occurrence of a motor burnout. If the oil is black and contains metal flakes, a mechanical failure has occurred. This symptom is often accompanied by a high compressor amperage draw.

Refer to the refrigeration system in the maintenance section for details on testing and replacing oil.

Figure 50. 22.9 Ton operating pressure — standard efficiency (50Hz)

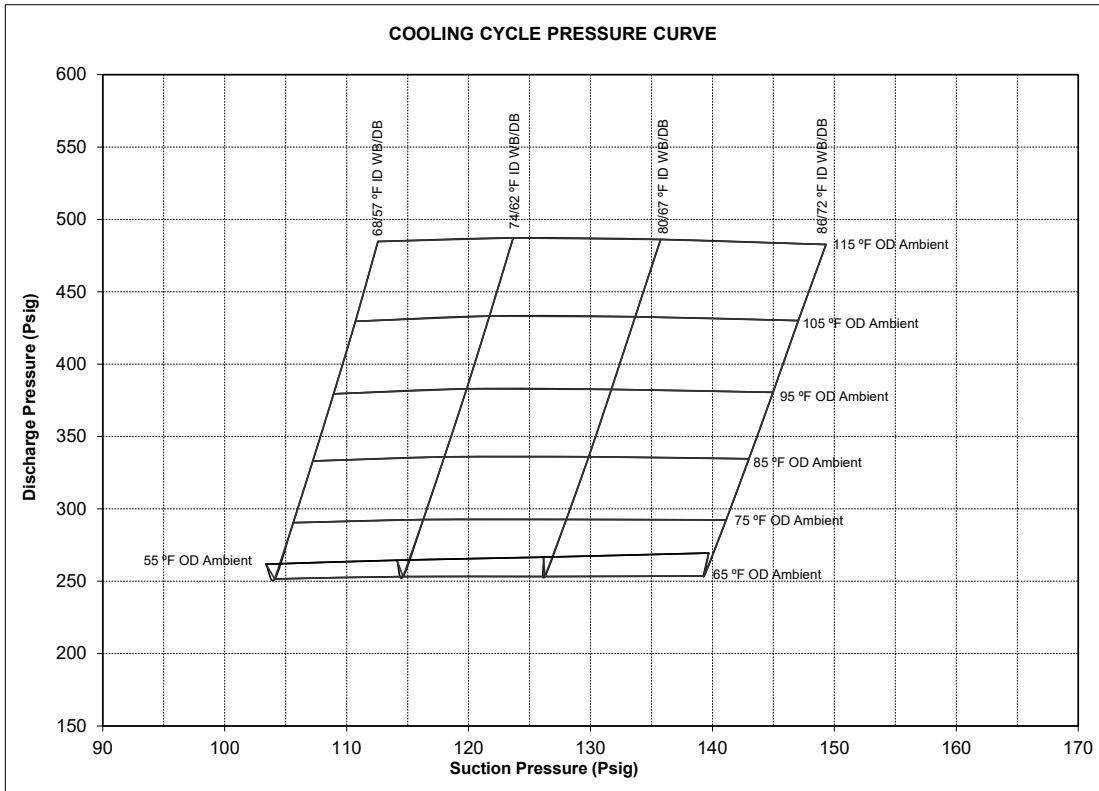


Figure 51. 24.5 Ton operating pressure — standard efficiency (50 Hz)

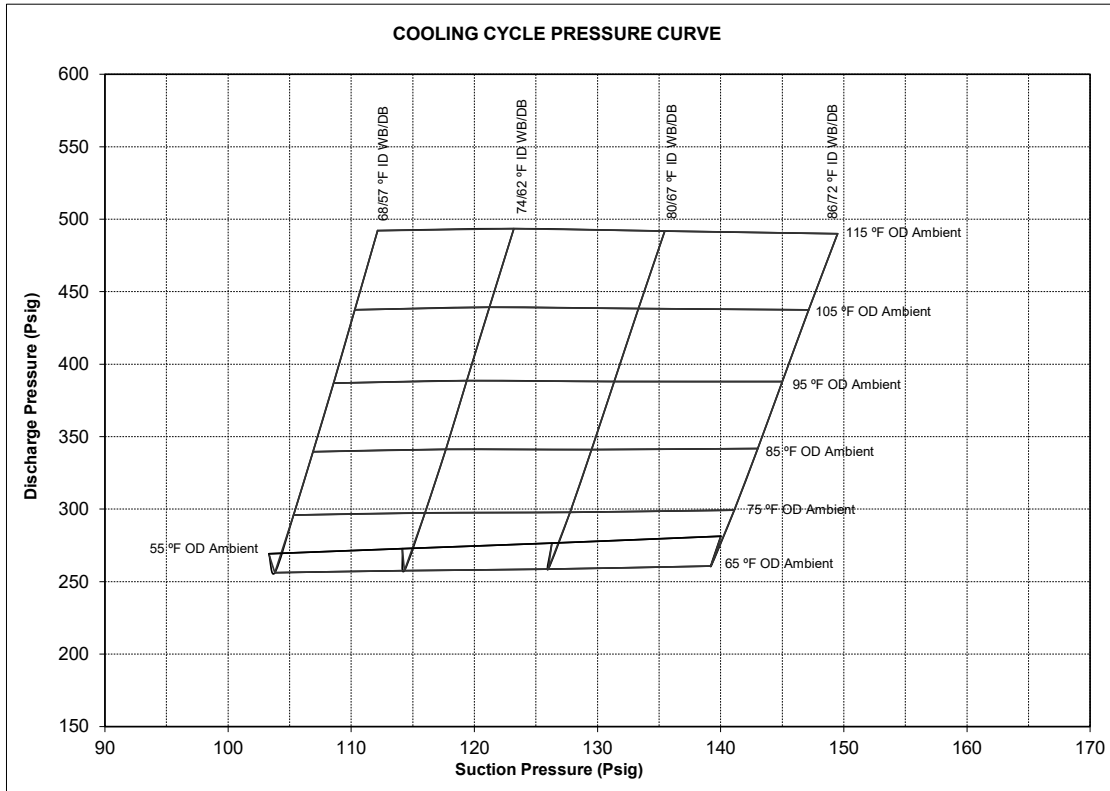
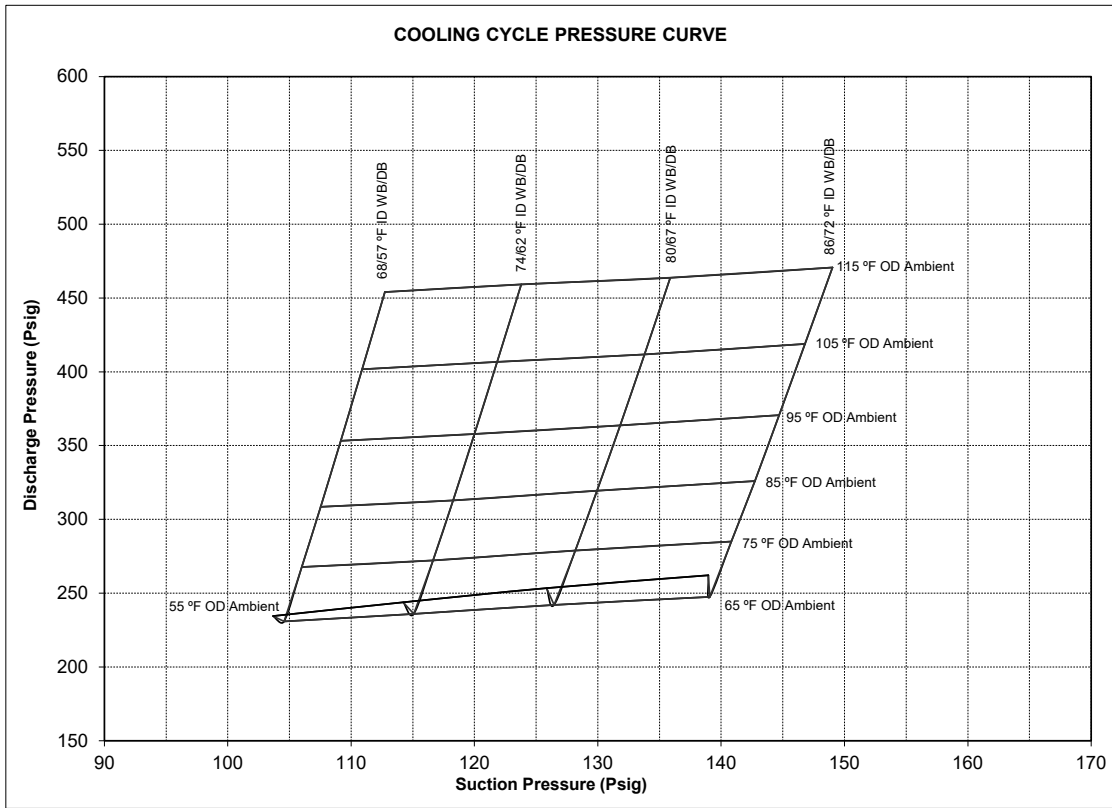
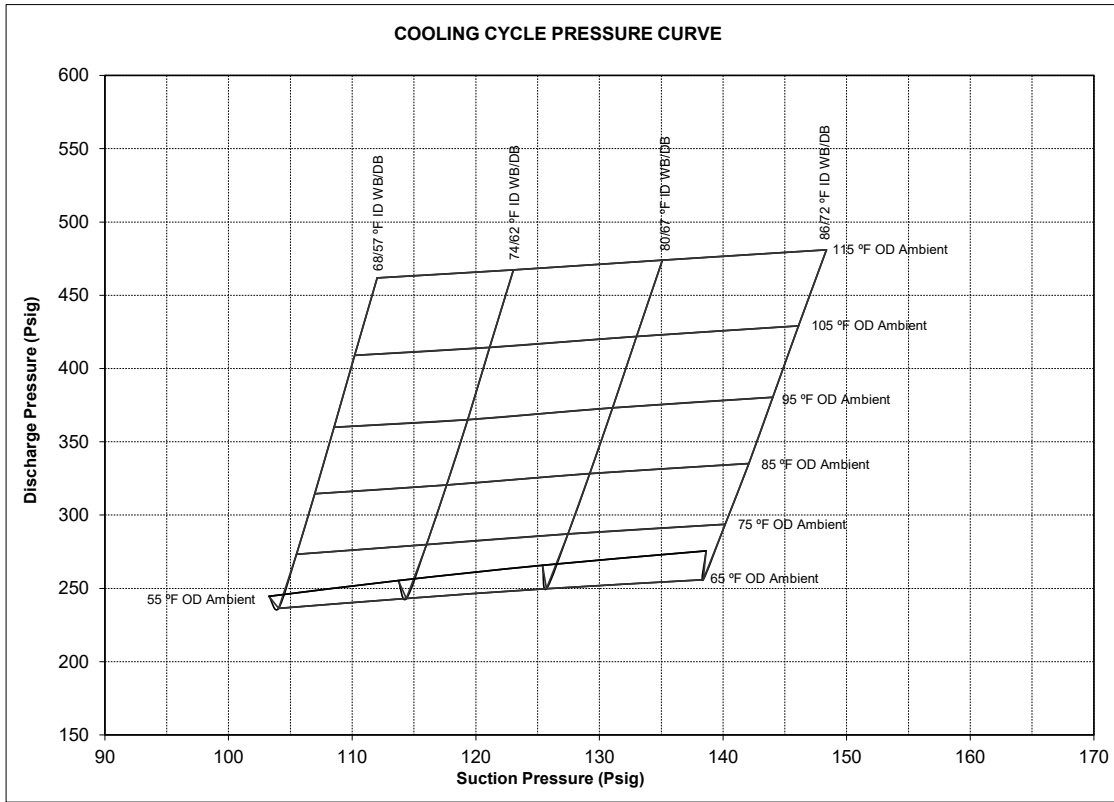


Figure 52. 22.9 Ton operating pressure — high efficiency (50 Hz)



**Figure 53. 24.5 Ton operating pressure — high efficiency (50 Hz)**



**Figure 54. 29.2 Ton operating pressure — standard efficiency (50Hz)**

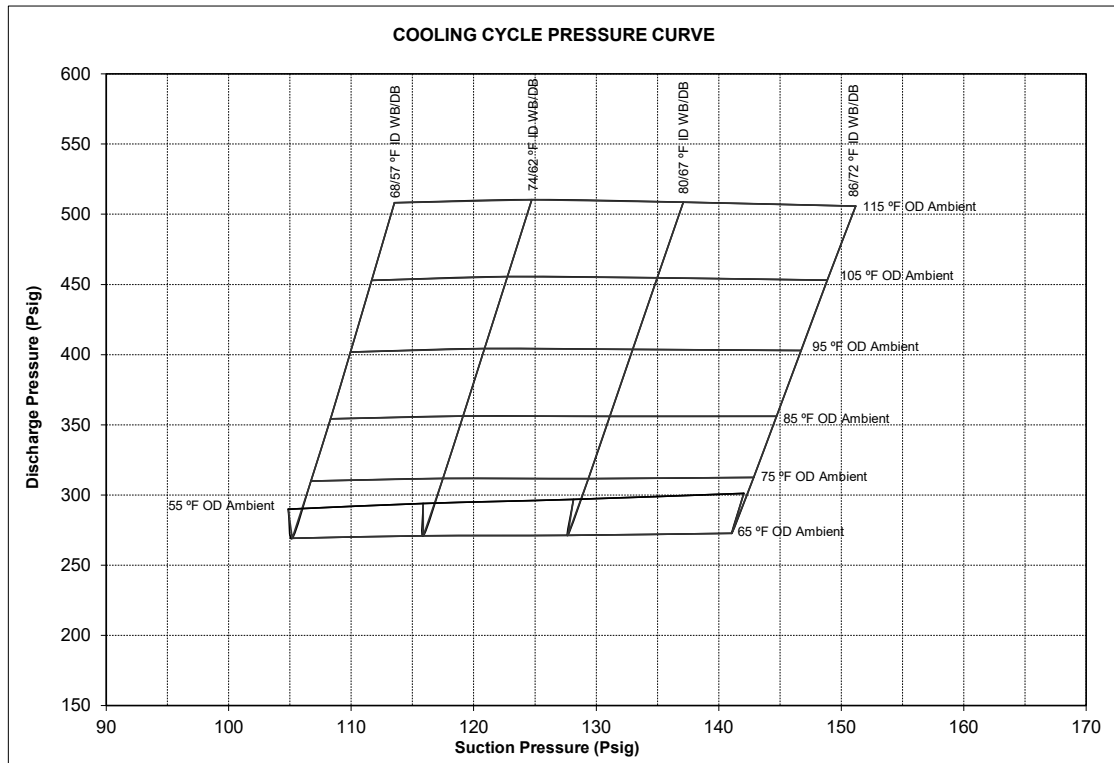


Figure 55. 29.2 Ton operating pressure —high efficiency (50Hz)

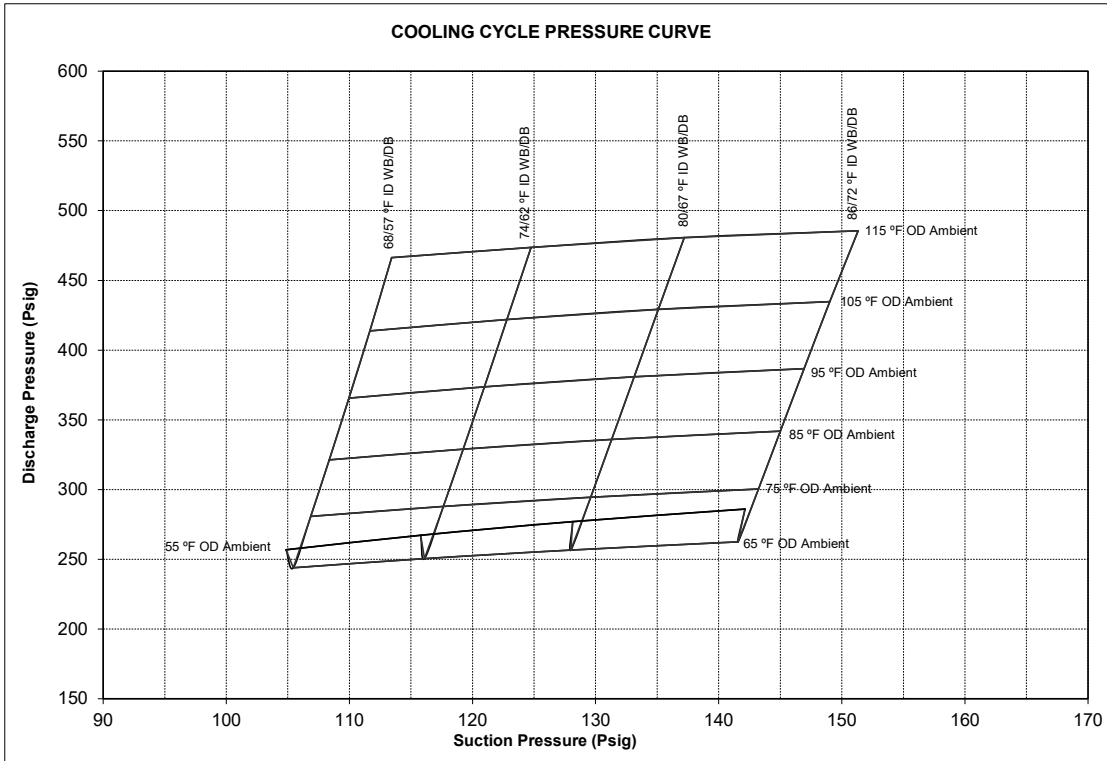


Figure 56. 33.3 Ton operating pressure —standard and high efficiency (50Hz)

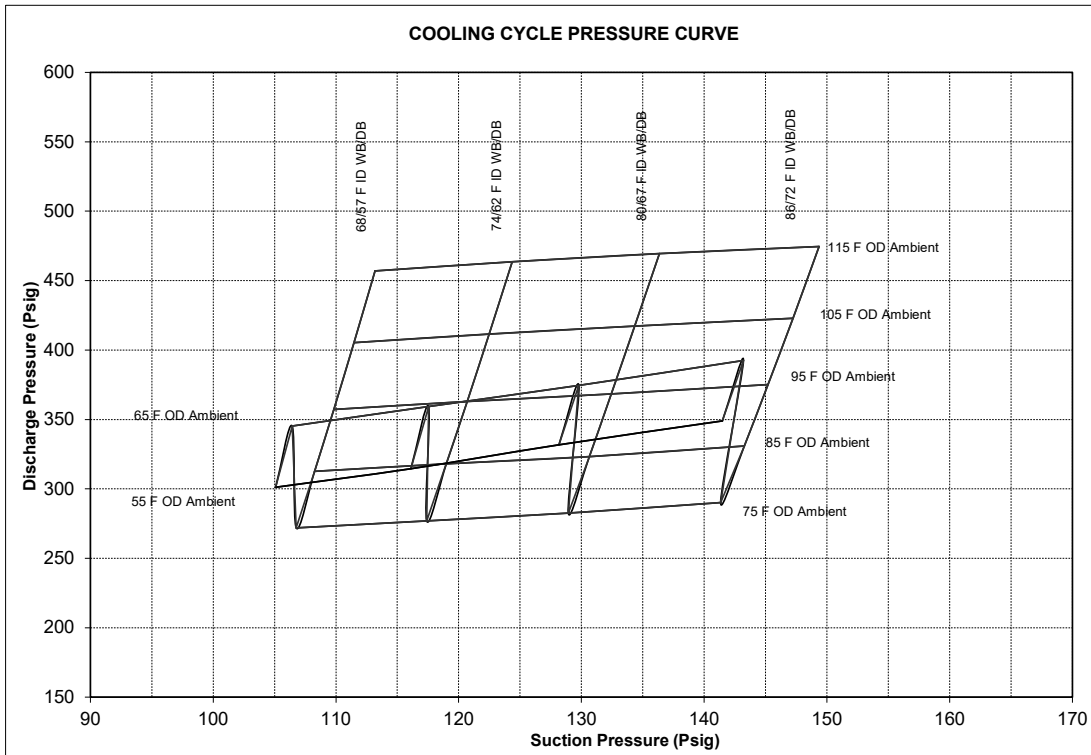




Figure 57. 41.7 Ton operating pressure — standard and high efficiency (50Hz)

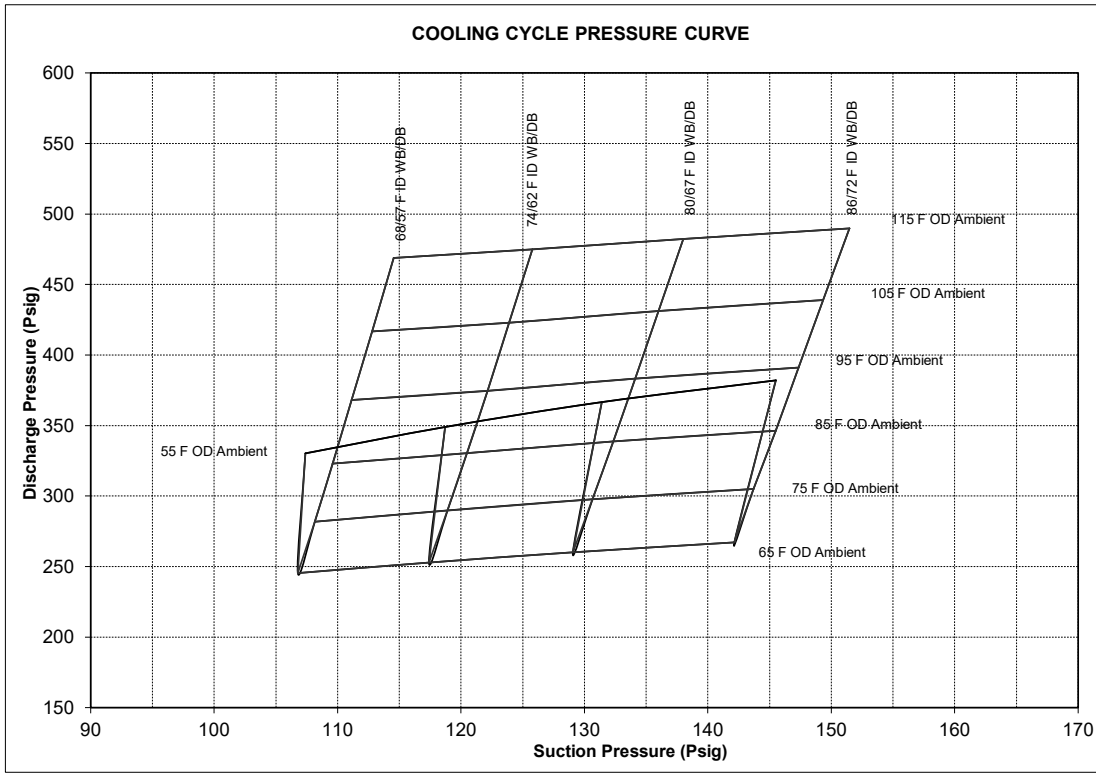


Figure 58. 27.5 Ton operating pressure — standard efficiency (60 Hz)

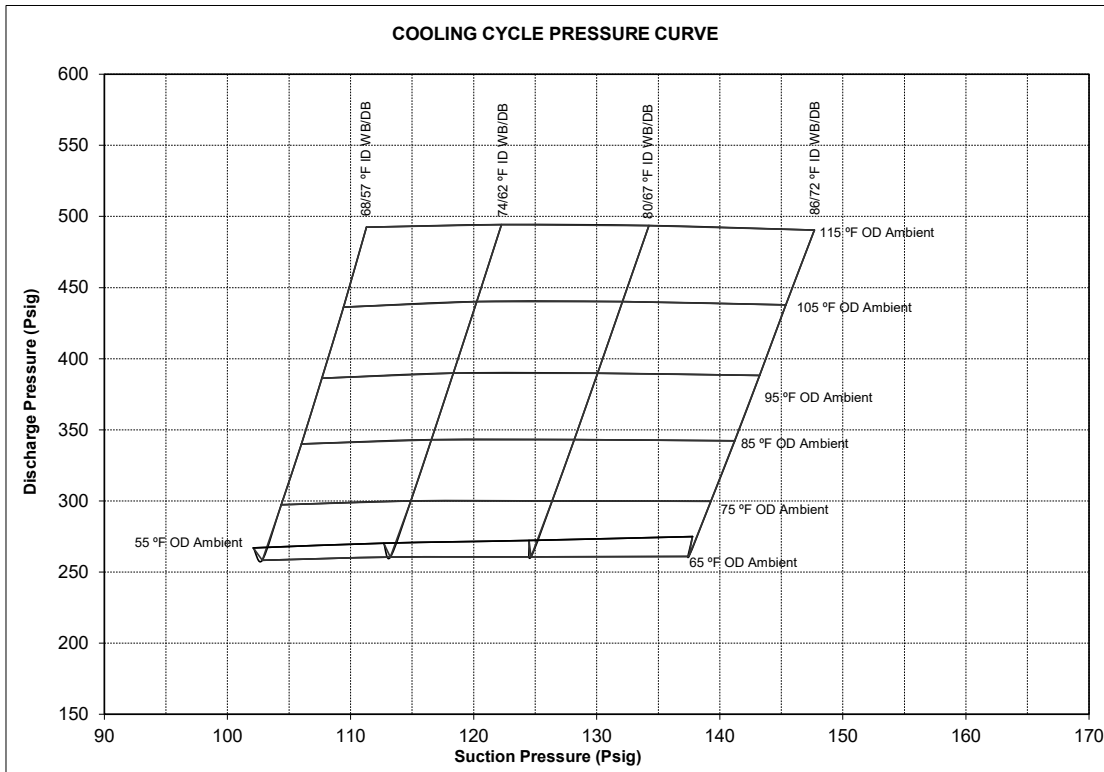


Figure 59. 27.5 Ton operating pressure — high efficiency (60 Hz)

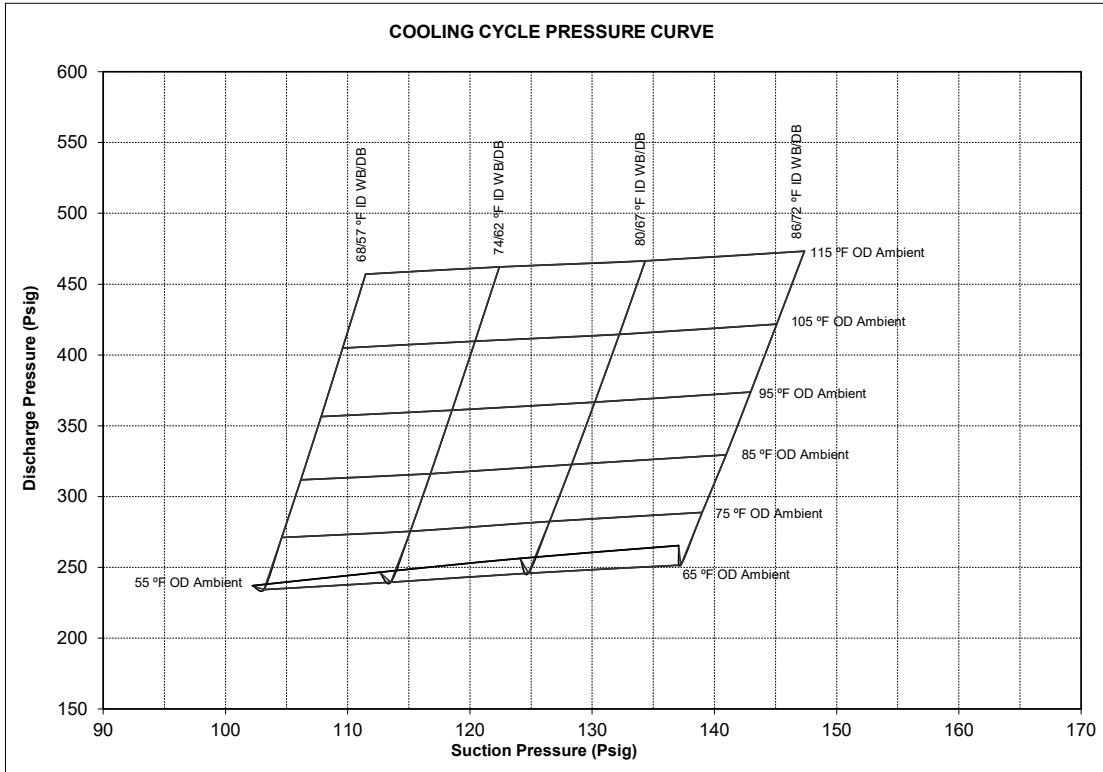


Figure 60. 30 Ton operating pressure — standard efficiency (60 Hz)

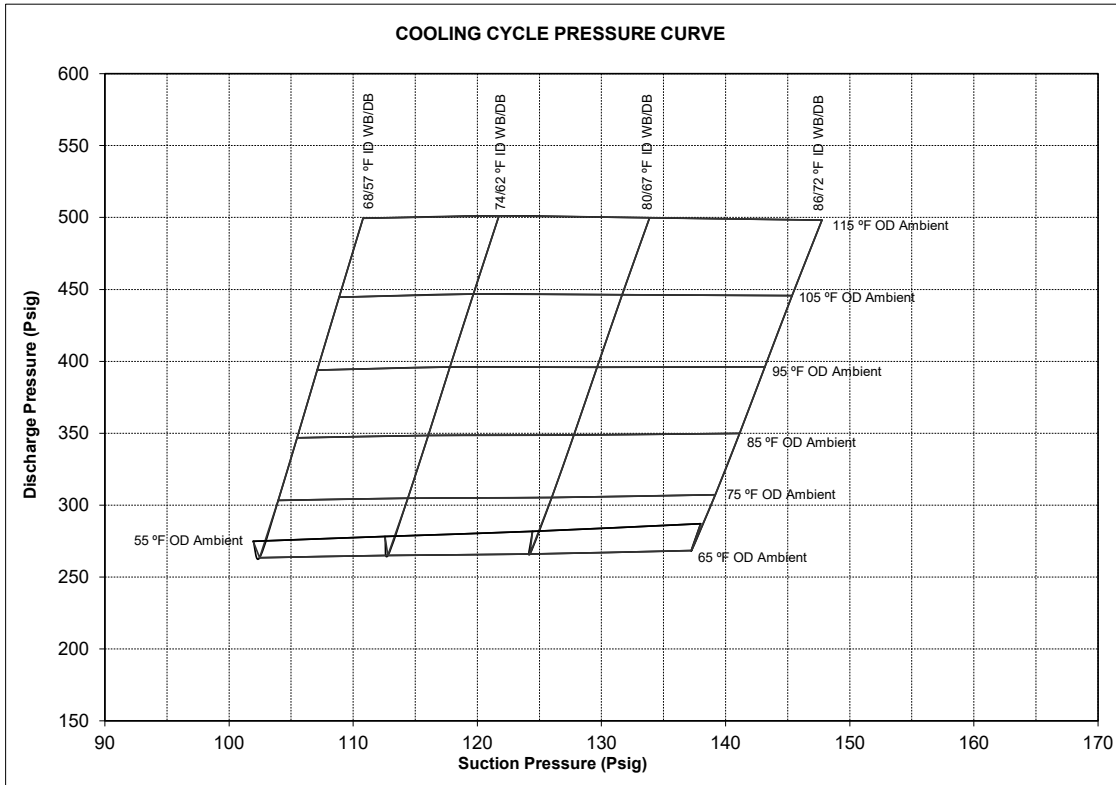


Figure 61. 30 Ton operating pressure — high efficiency (60 Hz)

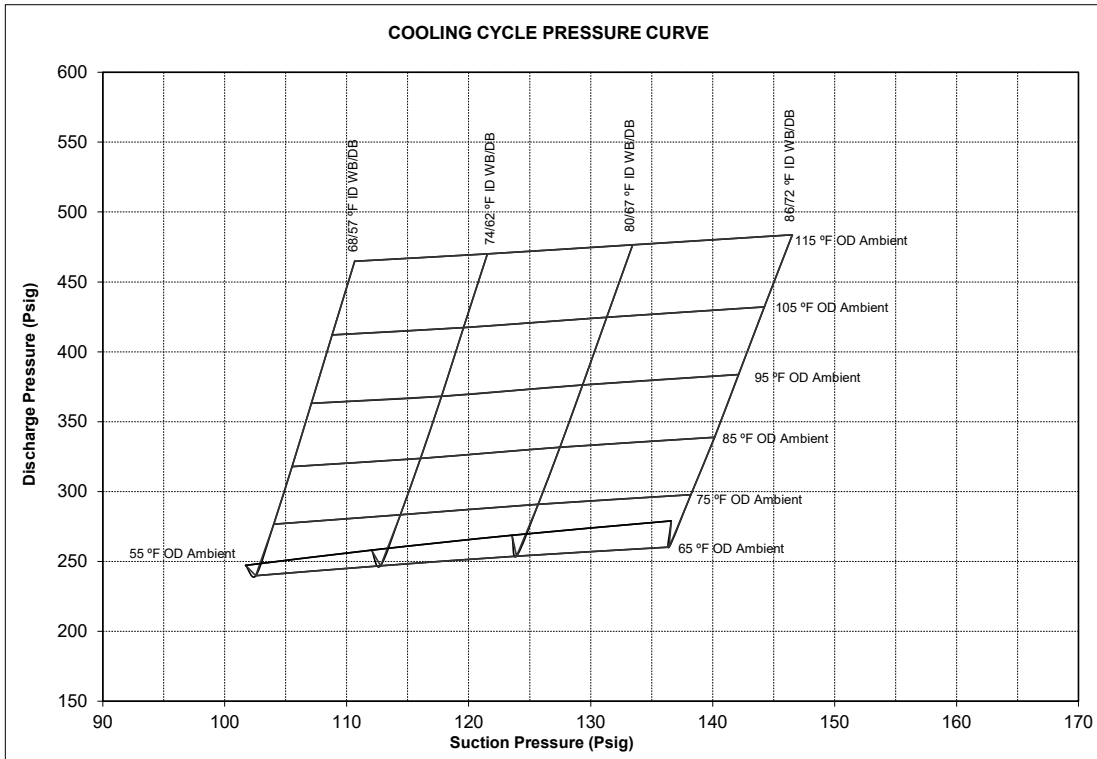


Figure 62. 35 Ton operating pressure — standard efficiency (60 Hz)

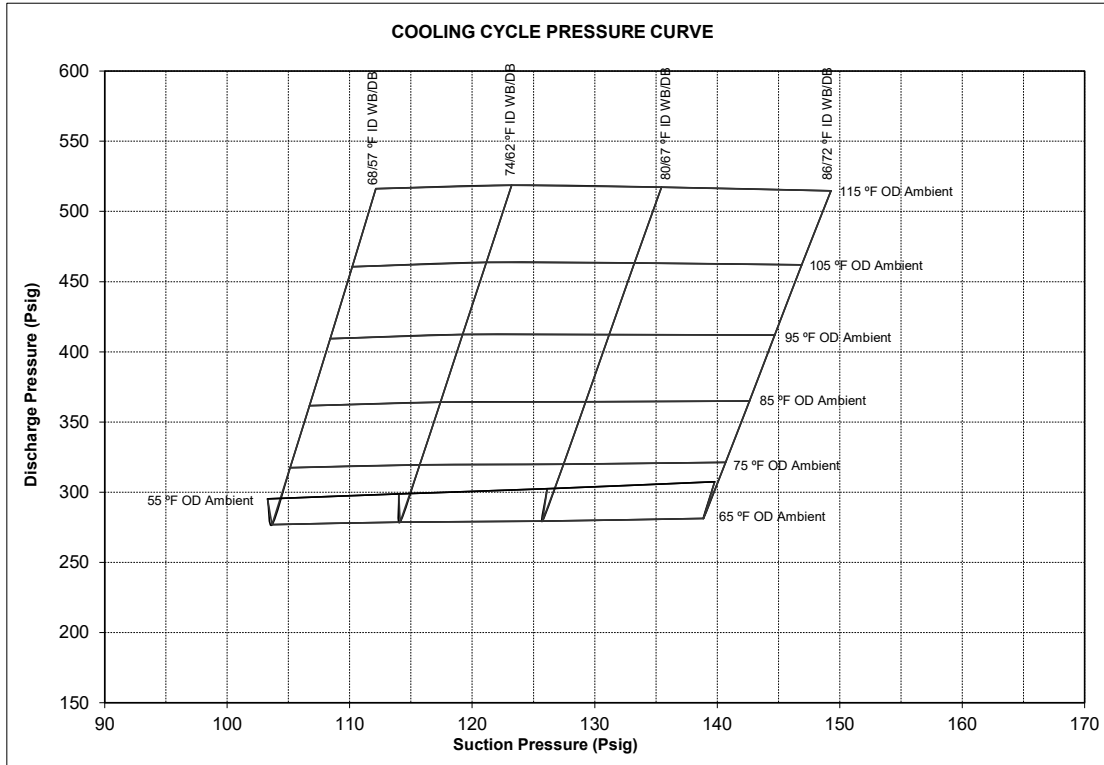
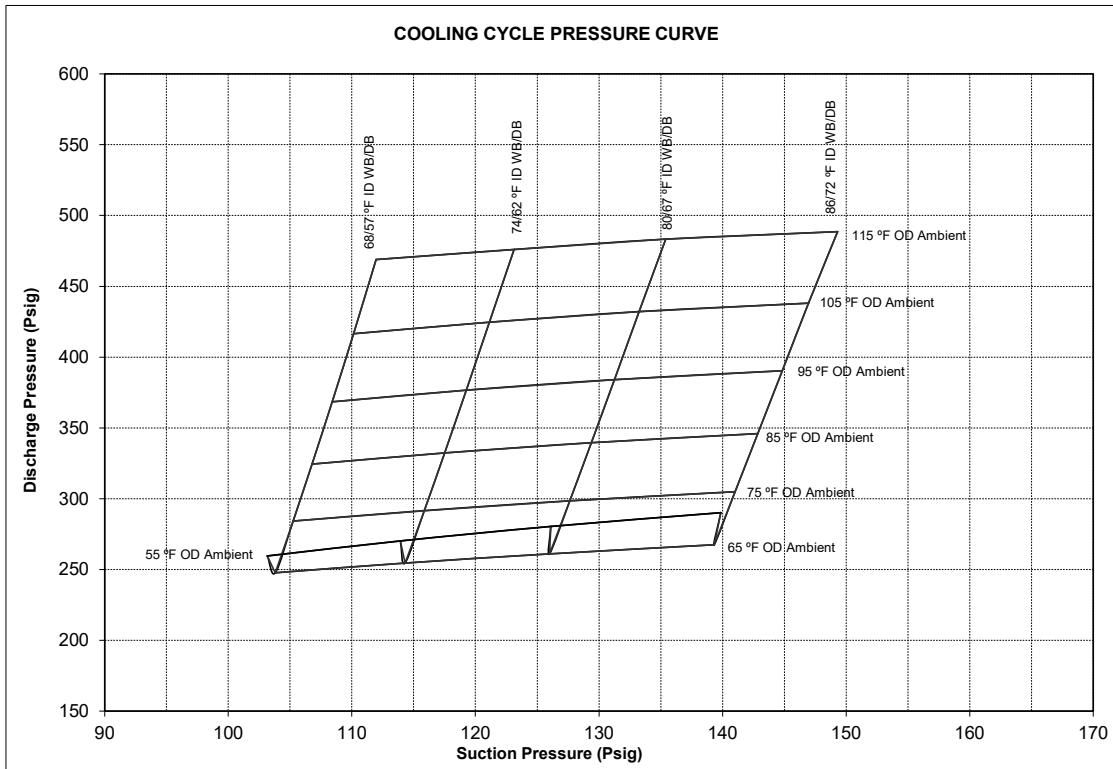
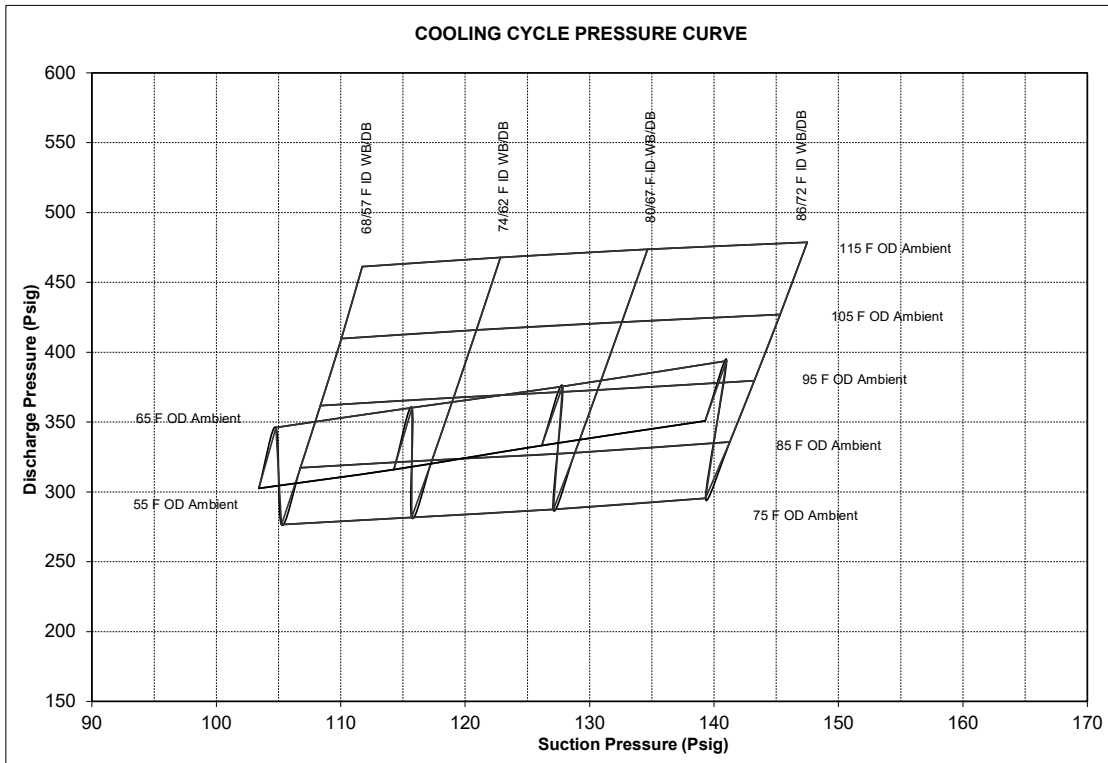


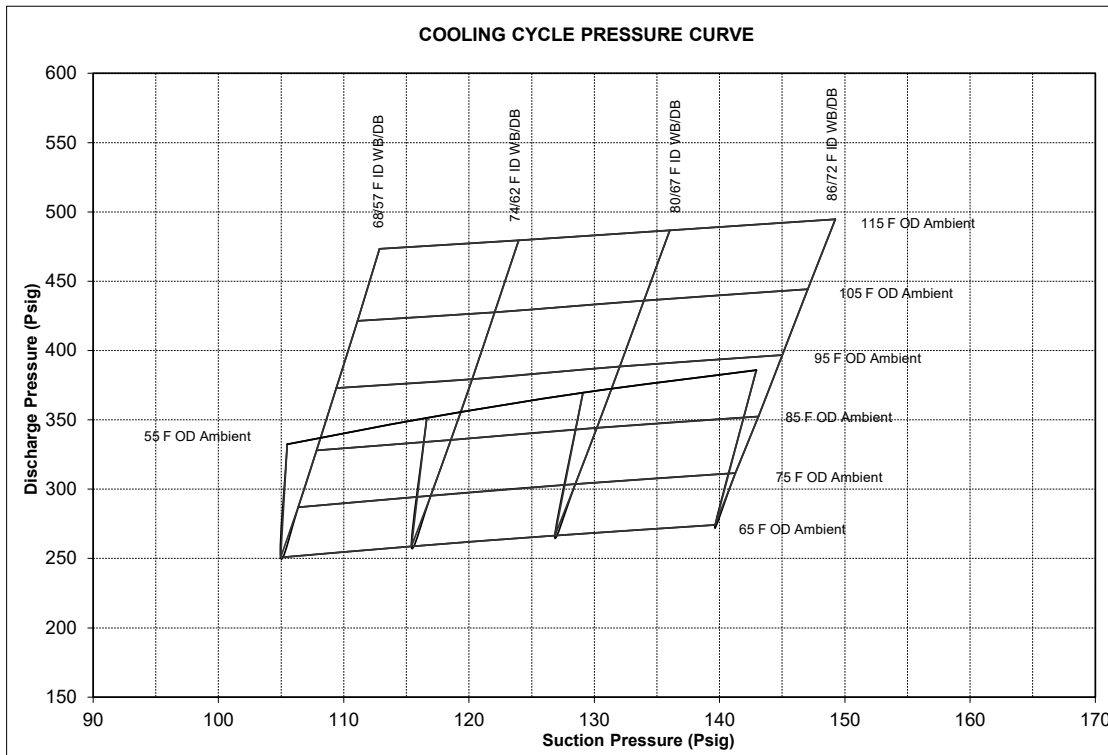
Figure 63. 35 Ton operating pressure — high efficiency (60 Hz)



**Figure 64. 40 Ton operating pressure — standard and high efficiency (60 Hz)**



**Figure 65. 50 Ton operating pressure — standard and high efficiency (60 Hz)**





## Startup

### Scroll Compressor Operational Noises

Because the scroll compressor is designed to accommodate liquids (both oil and refrigerant) and solid particles without causing compressor damage, there are some characteristic sounds that differentiate it from those typically associated with a reciprocating compressor. These sounds (which are described below) are characteristic, and do not affect the operation or reliability of the compressor.

#### At Shutdown

When a Scroll compressor shuts down, the gas within the scroll compressor expands and causes momentary reverse rotation until the discharge check valve closes. This results in a “flutter” type sound.

#### At Low Ambient Startup

When the compressor starts up under low ambient conditions, the initial flow rate of the compressor is low due to the low condensing pressure. This causes a low differential across the thermal expansion valve that limits its capacity. Under these conditions, it is not unusual to hear the compressor rattle until the suction pressure climbs and the flow rate increases.

#### During Normal Operation

The scroll compressor emits a higher frequency tone (sound) than a reciprocating compressor.

### Compressor Crankcase Heaters

Each compressor is equipped with a crankcase heater. When the compressor is “Off”, the crankcase heater is energized. When the compressor is “On”, the crankcase heater is de-energized. The proper operation of the crankcase heater is important to maintain an elevated compressor oil temperature during the “Off” cycle which reduces the potential for refrigerant to migrate into the compressor oil.

If present during a compressor start, liquid refrigerant could damage compressor bearings due to reduced lubrication and eventually could cause compressor mechanical failures.

Prior to the initial start or when power to the unit has been “Off” for an extended period, allow the crankcase heater to operate a minimum of 8 hours before starting the unit.

#### Charging by Subcooling

The unit is shipped with a complete refrigerant charge. However, if it becomes necessary to add refrigerant, it should be done so by adding charge to obtain an acceptable subcooling as described below. Refer to the maintenance section for proper refrigerant charging practices.

The outdoor ambient temperature must be between 65° and 105° F and the relative humidity of the air entering the evaporator must be above 40 percent. When the

temperatures are outside of these ranges, measuring the operating pressures can be meaningless.

With the unit operating at “Full Circuit Capacity”, acceptable subcooling ranges between 8° F to 16° F.

### Measuring Subcooling

#### **⚠ WARNING**

#### **Refrigerant under High Pressure!**

**Failure to follow instructions below could result in an explosion which could result in death or serious injury or equipment damage.**

**System contains refrigerant under high pressure. Recover refrigerant to relieve pressure before opening the system. See unit nameplate for refrigerant type. Do not use non-approved refrigerants, refrigerant substitutes, or refrigerant additives.**

1. Measure the liquid line pressure. Using a Refrigerant R-545B pressure/temperature chart, convert the pressure reading into the corresponding saturated temperature.
2. Measure the actual liquid line temperature. To ensure an accurate reading, clean the line thoroughly where the temperature sensor will be attached. After securing the sensor to the line, insulate the sensor and line to isolate it from the ambient air.  
*Note: Glass thermometers do not have sufficient contact area to give an accurate reading.*
3. Determine the system subcooling by subtracting the actual liquid line temperature (measured in step 2) from the saturated liquid temperature (converted in step 1).

### Gas Heat Units

Open the main disconnect switch to shut the unit off.

Follow the Service Test instructions in the *Symbio 700 Controller with Voyager 3 Packaged Rooftop Air Conditioners* literature (BAS-SVU054\*-EN) to put the unit into active gas heat step.

When starting the unit for the first time or servicing the heaters, it is a good practice to start the heater with the main gas supply turned “Off”. The main gas supply valve is the quarter-turn valve located on the largest gas pipe leading to the customer connection.

All heating units have either two stage or modulating heat capabilities. Only 800 MBH heat models contain two heat exchangers. In staged units, the heat exchangers operate simultaneously at either the low or high fire state. In modulating units, the modulating furnace fires first and adjusts to the needed capacity. If more heat is required than the modulating can provide, the second bank is fired and the modulating bank again adjusts to the heating load present.

Check both ignition systems (if applicable) when going through the test procedures.

Once the ignition system and igniters have been checked, open the main power disconnect switch to reset the Symbio™ 700 controls.

### **⚠ WARNING**

#### **Hazardous Gases and Flammable Vapors!**

Failure to observe the following instructions could result in exposure to hazardous gases, fuel substances, or substances from incomplete combustion, which could result in death or serious injury. The state of California has determined that these substances may cause cancer, birth defects, or other reproductive harm.

Improper installation, adjustment, alteration, service or use of this product could cause flammable mixtures or lead to excessive carbon monoxide. To avoid hazardous gases and flammable vapors follow proper installation and setup of this product and all warnings as provided in this manual.

Turn the main gas supply to the unit “On” and check the gas pressure at the unit’s gas train. Refer to “[Installation Piping](#),” p. 40 for the proper gas supply pressure and for the location of the gas pressure taps.

Close the main power disconnect switch and in the Symbio 700 user interface, select Service Test step Heat 1 to initiate the first stage of heat operation. Wait approximately 60 seconds for the heater to switch to low fire and check the manifold gas pressure. The manifold pressure for all furnaces is 3.5in. w.c. for Natural Gas and 10in w.c. for LP. For modulating burners, expect to see the manifold pressure reading fluctuate while the burner is operating, but it should never read negative.

### **⚠ WARNING**

#### **Hot Surface!**

Failure to follow instructions below could result in severe burns.

Surface temperatures may exceed 300°F (150°C). To avoid possible skin burns, stay clear of these surfaces. If possible, allow surfaces to cool before servicing. If servicing is necessary while surface temperatures are still elevated, you **MUST** put on all Personal Protective Equipment (PPE).

In the Symbio 700 user interface, select Service Test step Heat 2 to initiate second stage heat operation (if applicable). The combustion blower motor should go to high speed. The second stage of heat in units with modulating gas will initiate the second heater bank to fire and both banks will operate at high fire.

**Note:** When firing a modulating unit for the first time, a “humming”, or resonance sound may be heard. This is an operational sound made by the burner screen as it burns in. This sound is not a concern unless it persists longer than the first few times the unit is fired.

## **Electric Heat Units**

Start the service test steps Heat 1 or Heat 2 (if applicable), and check the amperage draw for each heating stage. Refer to the heater electrical data in (60 Hz) and (50 Hz) for the full load amps of a specific heater size.

Once the operation of the heaters have been checked, open the main power disconnect switch or the unit mounted disconnect switch to shut the unit “Off.”

This concludes the setup and testing for the major components and controls within the unit. Follow the Test guide in - to verify that the optional VFD, economizer actuator, and minimum ventilation controls are functioning.

## **Final Unit Checkout**

After completing all of the checkout and startup procedures outlined in the previous sections (i.e., operating the unit in each of its modes through all available stages of cooling and heating), perform these final checks before leaving the unit:

Verify that the Symbio 700 is in the normal operation mode.

### **For All Units**

The Symbio™ 700 controls have input setpoints inside the controller that are set at the factory which will allow the unit to operate and maintain system control. For specific job specifications:

- Verify that the control setpoints are set according to the job specifications, i.e.;
  - Outside air reset temperature - \_\_\_\_\_ Setpoint
  - Reset amount °F. - \_\_\_\_\_ Setpoint
  - Static pressure - \_\_\_\_\_ Setpoint
  - Static pressure deadband - \_\_\_\_\_ Setpoint
  - Discharge air temperature - \_\_\_\_\_ Setpoint
  - Morning warm up temperature - \_\_\_\_\_ Setpoint
  - Exhaust Fan - \_\_\_\_\_ Setpoint
- Inspect the unit for misplaced tools, hardware and debris.
- Verify that all unit exterior panels—including the control panel doors—are secured in place.

### **For Single Zone Variable Air Volume Units**

Verify that the “Mode” selection switch and the “Zone Temperature” setpoints are set and/or programmed at the sensor modules.



## Startup

---

The Symbio™ 700 controls have input setpoint inside the controller that are set at the factory which will allow the unit to operate and maintain system control. For specific job specifications:

- Verify that the setpoints are set according to the job specifications:
  - DA Heat - \_\_\_\_\_Setpoint
  - DA Cool - Fan SPD - \_\_\_\_\_Setpoint
  - EXH Fan - \_\_\_\_\_Setpoint
- Inspect the unit for misplaced tools, hardware and debris.
- Verify that all unit exterior panels—including the control panel doors—are secured in place.





# Sequence of Operation

See Symbio™ 700 Controller with Voyager 3 Packaged Rooftop Air-Conditioners Application Guide (BAS-APG048\*-EN).

# Maintenance

## Fan Belt Adjustment

The supply fan belts must be inspected periodically to assure proper unit operation.

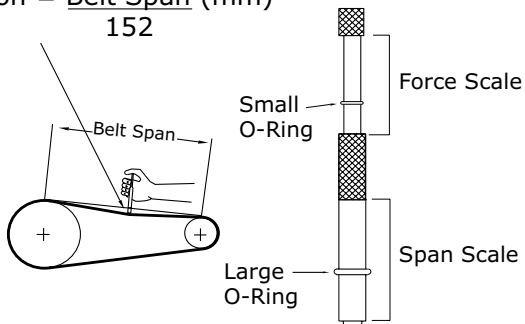
Replacement is necessary if the belts appear frayed or worn. Units with dual belts require a matched set of belts to ensure equal belt length. When installing new belts, do not stretch them over the sheaves; instead, loosen the adjustable motor-mounting base.

Once the new belts are installed, adjust the belt tension using a Browning or Gates tension gauge (or equivalent) illustrated in [Figure 66, p. 82](#).

**Figure 66. Typical belt tension gauge**

$$\text{Deflection} = \frac{\text{Belt Span (in.)}}{64}$$

$$\text{Deflection} = \frac{\text{Belt Span (mm)}}{152}$$



### ⚠ WARNING

#### Hazardous Voltage w/Capacitors!

Failure to disconnect power and discharge capacitors before servicing could result in death or serious injury.

Disconnect all electric power, including remote disconnects and discharge all motor start/run capacitors before servicing. Follow proper lockout/tagout procedures to ensure the power cannot be inadvertently energized. For variable frequency drives or other energy storing components provided by Trane or others, refer to the appropriate manufacturer's literature for allowable waiting periods for discharge of capacitors. Verify with a CAT III or IV voltmeter rated per NFPA 70E that all capacitors have discharged.

1. To determine the appropriate belt deflection:
  - a. Measure the center-to-center distance, in inches, between the fan sheave and the motor sheave.
  - b. Divide the distance measured in Step 1a by 64; the resulting value represents the amount of belt deflection for the proper belt tension.
2. Set the large O-ring on the belt tension gauge at the deflection value determined in Step 1b.
3. Set the small O-ring at zero on the force scale of the gauge.
4. Place the large end of the gauge on the belt at the center of the belt span. Depress the gauge plunger until the large O-ring is even with the of the second belt or even with a straightedge placed across the sheaves.
5. Remove the tension gauge from the belt. Notice that the small O-ring now indicates a value other than zero on the force scale. This value represents the force (in pounds) required to deflect the belt(s) the proper distance when properly adjusted.
6. Compare the force scale reading in step 5 with the appropriate "force" value in [Table 35, p. 83](#). If the force reading is outside of the listed range for the type of belts used, either readjust the belt tension or contact a qualified service representative.
 

**Note:** The actual belt deflection force must not exceed the maximum value shown in [Table 35, p. 83](#).
7. Recheck the new belt's tension at least twice during the first 2 to 3 days of operation. Readjust the belt tension as necessary to correct for any stretching that may have occurred. Until the new belts are "run in", the belt tension will decrease rapidly as they stretch.

**Table 35. Belt tension measurements and deflection forces**

Belts Cross Section	Small P.D Range	Deflection Force (Lbs.)									
		Super Gripbelts		Gripnotch		Steel Cable Gripbelts		358 Gripbelts		358 Gripnotch Belts	
		Min.	Max.	Min.	Max.	Min.	Max.	Min.	Max.	Min.	Max.
A	3.0 - 3.6	3	4 1/2	3 7/8	5 1/2	3 1/4	4	—	—	—	—
	3.8 - 4.8	3 1/2	5	4 1/2	6 1/4	3 3/4	4 3/4	—	—	—	—
	5.0 - 7.0	4	5 1/2	5	6 7/8	4 1/4	5 1/4	—	—	—	—
B	3.4 - 4.2	4	5 1/2	5 3/4	8	4 1/2	5 1/2	—	—	—	—
	4.4 - 5.6	5 1/8	7 1/8	6 1/2	9 1/8	5 3/4	7 1/4	—	—	—	—
	5.8 - 8.8	6 3/8	8 3/4	7 3/8	10 1/8	7	8 3/4	—	—	—	—
5V	4.4 - 8.7	—	—	—	—	—	—	—	—	10	15
	7.1 - 10.9	—	—	—	—	—	—	10 1/2	15 3/4	12 7/8	18 3/4
	11.8 - 16.0	—	—	—	—	—	—	13	19 1/2	15	22

**Table 36. Supply fan sheave and belt**

Tons	Motor	RPM	Fan Sheave <sup>(a) (b) (c)</sup>		Fan Bushing		Motor Sheave <sup>(d)</sup>		Motor Bushing <sup>(e)</sup>		Belt
			Browning	SST	Browning	SST	Browning	SST	Browning	SST	
27.5, 30, and 35	7.5 hp	550	BK190 X 1 7/16	BK190-1-7/16			BK62H	BK62H	H 1-3/8	H-1-3/8	BX108 Notched
		600	BK160 X 1 7/16	BK160-1-7/16			BK57H	BK57H	H 1-3/8	H-1-3/8	BX100 Notched
		650	BK160 X 1 7/16	BK160-1-7/16			BK62H	BK62H	H 1-3/8	H-1-3/8	BX103 Notched
27.5, 30, and 35	10 hp	650	BK190 X 1 7/16	BK190-1-7/16			BK75H	BK75H	H 1-3/8	H-1-3/8	BX108 Notched
		700	BK160 X 1 7/16	BK160-1-7/16			BK67H	BK67H	H 1-3/8	H-1-3/8	BX103 Notched
		750	BK160 X 1 7/16	BK160-1-7/16			BK72H	BK72H	H 1-3/8	H-1-3/8	BX103 Notched
		800	BK160 X 1 7/16	BK160-1-7/16			BK75H	BK75H	H 1-3/8	H-1-3/8	BX103 Notched
27.5, 30, and 35	15 hp	700	1B5V160	1B160SK	B 1 7/16	SK 1 7/16	1B5V64	1B64SDS	B 1 5/8	SDS 1 5/8	BX103 Notched
		750	BK160 X 1 7/16	BK160-1-7/16			1B5V66	1B66SDS	B 1 5/8	SDS 1 5/8	BX103 Notched
		800	BK160 X 1 7/16	BK160-1-7/16			1B5V70	1B70SDS	B 1 5/8	SDS 1 5/8	BX103 Notched
		850	2B5V124	2B124SK	B 1 7/16	SK 1 7/16	2B5V58	2B58SDS	B 1 5/8	SDS 1 5/8	BX95 Notched
		900	2B5V124	2B124SK	B 1 7/16	SK 1 7/16	2B5V62	2B62SDS	B 1 5/8	SDS 1 5/8	BX95 Notched
35	20 hp	850	2B5V124	2B124SK	B 1 7/16	SK 1 7/16	2B5V58	2B58SDS	B 1 5/8	SDS 1 5/8	BX95 Notched
		900	2B5V124	2B124SK	B 1 7/16	SK 1 7/16	2B5V62	2B62SDS	B 1 5/8	SDS 1 5/8	BX95 Notched



**Maintenance**

**Table 36. Supply fan sheave and belt (continued)**

Tons	Motor	RPM	Fan Sheave <sup>(a) (b) (c)</sup>		Fan Bushing		Motor Sheave <sup>(d)</sup>		Motor Bushing <sup>(e)</sup>		Belt
			Browning	SST	Browning	SST	Browning	SST	Browning	SST	
40	10 hp	500	2B5V124	2B124SK	B 1 11/16	SK 1 11/16	2BK36H	2BK36H	H 1-3/8	H-1-3/8	BX95 Notched
		525	2B5V124	2B124SK	B 1 11/16	SK 1 11/16	2BK40H	2BK40H	H 1-3/8	H-1-3/8	BX95 Notched
		575	2B5V124	2B124SK	B 1 11/16	SK 1 11/16	2BK45H	2BK45H	H 1-3/8	H-1-3/8	BX95 Notched
	15 hp	625	2B5V124	2B124SK	B 1 11/16	SK 1 11/16	2B5V42	2B42SH	P1 1-5/8	SH 1 5/8	BX95 Notched
		675	2B5V136	2B136SK	B 1 11/16	SK 1 11/16	2B5V50	2B50SDS	B 1 5/8	SDS 1 5/8	BX97 Notched
		725	2B5V136	2B136SK	B 1 11/16	SK 1 11/16	2B5V54	2B54SDS	B 1 5/8	SDS 1 5/8	BX97 Notched
	20 hp	725	2B5V136	2B136SK	B 1 11/16	SK 1 11/16	2B5V54	2B54SDS	B 1 5/8	SDS 1 5/8	BX97 Notched
		775	2B5V136	2B136SK	B 1 11/16	SK 1 11/16	2B5V58	2B58SDS	B 1 5/8	SDS 1 5/8	BX97 Notched
		800	2B5V136	2B136SK	B 1 11/16	SK 1 11/16	2B5V60	2B60SDS	B 1 5/8	SDS 1 5/8	BX97 Notched
50	10 hp	525	2B5V124	2B124SK	B 1 11/16	SK 1 11/16	2BK40H	2BK40H	H 1-3/8	H-1-3/8	BX95 Notched
		575	2B5V124	2B124SK	B 1 11/16	SK 1 11/16	2BK45H	2BK45H	H 1-3/8	H-1-3/8	BX95 Notched
	15 hp	625	2B5V124	2B124SK	B 1 11/16	SK 1 11/16	2B5V42	2B42SH	P1 1-5/8	SH 1 5/8	BX95 Notched
		675	2B5V136	2B136SK	B 1 11/16	SK 1 11/16	2B5V50	2B50SDS	B 1 5/8	SDS 1 5/8	BX97 Notched
		725	2B5V136	2B136SK	B 1 11/16	SK 1 11/16	2B5V54	2B54SDS	B 1 5/8	SDS 1 5/8	BX97 Notched
	20 hp	725	2B5V136	2B136SK	B 1 11/16	SK 1 11/16	2B5V54	2B54SDS	B 1 5/8	SDS 1 5/8	BX97 Notched
		775	2B5V136	2B136SK	B 1 11/16	SK 1 11/16	2B5V58	2B58SDS	B 1 5/8	SDS 1 5/8	BX97 Notched
	25 hp	725	2B5V160	2B160SK	B 1 11/16	SK 1 11/16	2B5V64	2B64SDS	B 1 7/8	SDS 1 7/8	BX103 Notched
		775	2B5V154	2B154SK	B 1 11/16	SK 1 11/16	2B5V66	2B66SDS	B 1 7/8	SDS 1 7/8	BX103 Notched
825		2B5V154	2B154SK	B 1 11/16	SK 1 11/16	2B5V70	2B70SK	B 1 7/8	SK 1 7/8	BX103 Notched	

(a) Browning BK160 X 1 7/16 and SST BK160-1-7/16 sheaves are interchangeable.  
 (b) Browning BK190 X 1 7/16 and SST BK190-1-7/16 sheaves are interchangeable.  
 (c) All other sheaves & bushings are interchangeable only in sheave/bushing combination sets. Sets do not mix vendors.  
 (d) Browning and SST sheaves with identical numbers are interchangeable and can be used with each other's bushings.  
 (e) Browning H 1-3/8 and SST H-1-3/8 bushings are interchangeable and can be used with each other's sheaves.

## Monthly Maintenance

### ⚠ WARNING

#### Hazardous Voltage w/Capacitors!

Failure to disconnect power and discharge capacitors before servicing could result in death or serious injury.

Disconnect all electric power, including remote disconnects and discharge all motor start/run capacitors before servicing. Follow proper lockout/tagout procedures to ensure the power cannot be inadvertently energized. For variable frequency drives or other energy storing components provided by Trane or others, refer to the appropriate manufacturer's literature for allowable waiting periods for discharge of capacitors. Verify with a CAT III or IV voltmeter rated per NFPA 70E that all capacitors have discharged.

Before completing the following checks, turn the unit **OFF** and lock the main power disconnect switch open.

### Filters

Inspect the return air filters. Clean or replace them if necessary. Refer to the table below for filter information.

**Table 37. Filters**

Unit Model	Quantity	Filter Dimension (inches) <sup>(a)</sup>
TC, TE, YC*330 - 420	16	15½ X 19½ X 2 or 4
TC, TE, YC*480 & 600	17	15½ X 19½ X 2 or 4

<sup>(a)</sup> Filter dimensions are actual. Nominal filter size is 16 x 20.

### Condensate Overflow Switch

During maintenance, the switch float (black ring) must be checked to ensure free movement up and down.

### Cooling Season

### ⚠ WARNING

#### Hazardous Voltage!

Failure to disconnect power before servicing could result in death or serious injury.

Disconnect all electric power, including remote disconnects before servicing. Follow proper lockout/tagout procedures to ensure the power can not be inadvertently energized. Verify that no power is present with a voltmeter.

- Check the unit's drain pans and condensate piping to ensure that there are no blockages.
- Inspect the evaporator and condenser coils for dirt, bent fins, etc. If the coils appear dirty, clean them according to the instructions described in "Coil Cleaning" later in this section.

- Inspect the fresh air and return air damper hinges and pins to ensure that all moving parts are securely mounted. Keep the blades clean as necessary.

### ⚠ WARNING

#### Rotating Components!

Failure to disconnect power before servicing could result in rotating components cutting and slashing technician which could result in death or serious injury.

During installation, testing, servicing and troubleshooting of this product it may be necessary to work with live and exposed rotating components. Have a qualified or licensed service individual who has been properly trained in handling exposed rotating components, perform these tasks.

- Manually rotate the condenser fans to ensure free movement and check motor bearings for wear. Verify that all of the fan mounting hardware is tight.
- Verify that all damper linkages move freely; lubricate with white grease, if necessary.
- Check supply fan motor bearings; repair or replace the motor as necessary.
- Check the fan shaft bearings for wear. Replace the bearings as necessary.

**Note:** These bearings are considered permanently lubricated for normal operation. For severe dirty applications, if relubrication becomes necessary, use a lithium based grease. See [Table 38, p. 86](#) for recommended greases.

**Important:** The bearings are manufactured using a special synthetic lithium-based grease designed for long life and minimum relube intervals. Over lubrication can be just as harmful as not enough.

- Use a hand grease gun to lubricate these bearings; add grease until a light bead appears all around the seal. Do not over lubricate! After greasing the bearings, check the setscrews to ensure that the shaft is held securely. Make sure that all bearing braces are tight.
- Check the supply fan belt(s). If the belts are frayed or worn, replace them. Refer to the "Fan Belt Adjustment," [p. 82](#) for belt replacement and adjustments.
- Check the condition of the gasket around the control panel doors. These gaskets must fit correctly and be in good condition to prevent water leakage.
- Verify that all wire terminal connections are tight.
- Remove any corrosion present on the exterior surfaces of the unit and repaint these areas.
- Generally inspect the unit for unusual conditions (e.g., loose access panels, leaking piping connections, etc.)



## Maintenance

- Make sure that all retaining screws are reinstalled in the unit access panels once these checks are complete.
- With the unit running, check and record the following:
  - ambient temperature
  - compressor oil level (each circuit)
  - compressor suction and discharge pressures (each circuit)
  - superheat and subcooling (each circuit)

Record this data on an “operator’s maintenance log” like the one shown in . If the operating pressures indicate a refrigerant shortage, measure the system superheat and system subcooling. For guidelines, refer to “Charging by Subcooling,” p. 78.

**Important:** Do not release refrigerant to the atmosphere! If adding or removing refrigerant is required, the service technician must comply with all federal, state and local laws. Refer to general service bulletin MSCU-SB-1 (latest edition).

### Heating Season

#### **⚠ WARNING**

##### **Hazardous Voltage!**

Failure to disconnect power before servicing could result in death or serious injury.

Disconnect all electric power, including remote disconnects before servicing. Follow proper lockout/tagout procedures to ensure the power can not be inadvertently energized. Verify that no power is present with a voltmeter.

Before completing the following checks, turn the unit **OFF** and lock the main power disconnect switch open.

- Inspect the unit air filters. If necessary, clean or replace them.
- Check supply fan motor bearings; repair or replace the motor as necessary.
- Check the fan shaft bearings for wear. Replace the bearings as necessary.

**Note:** These bearing are considered permanently lubricated for normal operation. For severe dirty applications, if relubrication becomes necessary, use a lithium based grease. See Table 38, p. 86 for recommended greases.

**Important:** The bearings are manufactured using a special synthetic lithium-based grease designed for long life and minimum relube intervals. Over lubrication can be just as harmful as not enough.

- Use a hand grease gun to lubricate these bearings; add grease until a light bead appears all around the seal. Do not over lubricate!

- After greasing the bearings, check the setscrews to ensure that the shaft is held securely. Make sure that all bearing braces are tight.
- Inspect both the main unit control panel and heat section control box for loose electrical components and terminal connections, as well as damaged wire insulation. Make any necessary repairs.
- Gas units only - Check the heat exchanger(s) for any corrosion, cracks, or holes.
- Check the combustion air blower for dirt or blockage from animals or insects. Clean as necessary.

**Note:** The furnace will either have to be pulled out of the unit for cleaning or open the panel on right-hand side of unit to clean from the back. New furnaces cannot be cleaned in the same way as the drum and tube heat exchangers.

- Open the main gas valve and apply power to the unit heating section; then initiate a “Heat” test using the startup procedure described in “Gas Heat Units,” p. 78.

#### **⚠ WARNING**

##### **Hazardous Gases and Flammable Vapors!**

Failure to observe the following instructions could result in exposure to hazardous gases, fuel substances, or substances from incomplete combustion, which could result in death or serious injury. The state of California has determined that these substances may cause cancer, birth defects, or other reproductive harm. Improper installation, adjustment, alteration, service or use of this product could cause flammable mixtures or lead to excessive carbon monoxide. To avoid hazardous gases and flammable vapors follow proper installation and setup of this product and all warnings as provided in this manual.

- Verify that the ignition system operates properly.

**Table 38. Grease recommendations**

Recommended Grease	Recommended Operating Range
Exxon Unirex #2	-20 F to 250 F
Mobil 532	
Mobil SHC #220	
Texaco Premium RB	

### Coil Cleaning

Regular coil maintenance, including annual cleaning enhances the unit’s operating efficiency by minimizing the following:

- Compressor head pressure and amperage draw
- Water carryover

- Fan brake horsepower
- Static pressure losses

At least once each year—or more often if the unit is located in a “dirty” environment—clean the evaporator, microchannel condenser, and reheat coils using the instructions outlined below. Be sure to follow these instructions as closely as possible to avoid damaging the coils.

### ⚠ WARNING

#### **Hazardous Chemicals!**

**Failure to follow this safety precaution could result in death or serious injury. Coil cleaning agents can be either acidic or highly alkaline and can burn severely if contact with skin or eyes occurs.**

**Handle chemical carefully and avoid contact with skin. ALWAYS wear Personal Protective Equipment (PPE) including goggles or face shield, chemical resistant gloves, boots, apron or suit as required. For personal safety refer to the cleaning agent manufacturer’s Materials Safety Data Sheet and follow all recommended safe handling practices.**

## Refrigerant Coils

To clean refrigerant coils, use a soft brush and a sprayer.

For evaporator and reheat coil cleaners, contact the local Trane Parts Center for appropriate detergents.

1. Remove enough panels from the unit to gain safe access to coils.

### ⚠ WARNING

#### **No Step Surface!**

**Failure to follow instruction below could result in death or serious injury.**

**Do not walk on the sheet metal drain pan. Walking on the drain pan could cause the supporting metal to collapse and result in the operator/technician falling.**

*Note: Before attempting to enter the unit, bridge between the main supports. Bridging may consist of multiple 2 by 12 boards or sheet metal grating.*

2. For accessible areas, remove loose dirt and debris from both sides of the coil. For dual row microchannel

condenser coil applications, seek pressure coil wand extension through the local Trane Parts Center.

3. When cleaning fin and tube evaporator or reheat coils, mix the detergent with water according to the manufacturer’s instructions. If desired, heat the solution to 150° F maximum to improve its cleansing capability.

**Important: DO NOT use any detergents with microchannel coils. Pressurized water or air ONLY.**

4. Pour the cleaning solution into the sprayer. If a high-pressure sprayer is used:
  - a. The minimum nozzle spray angle is 15 degrees.
  - b. Do not allow sprayer pressure to exceed 600 psi.
  - c. Spray the solution perpendicular (at 90 degrees) to the coil face.
  - d. For evaporator and reheat coils, maintain a minimum clearance of 6" between the sprayer nozzle and the coil. For microchannel condenser coils, optimum clearance between the sprayer nozzle and the microchannel coil is 1"-3".
5. Spray the leaving-airflow side of the coil first; then spray the opposite side of the coil. For evaporator and reheat coils, allow the cleaning solution to stand on the coil for five minutes.
6. Rinse both sides of the coil with cool, clean water.
7. Inspect both sides of the coil; if it still appears to be dirty, repeat Steps 6 and 7.
8. Reinstall all of the components and panels removed in Step 1; then restore power to the unit.
9. For evaporator and reheat coils, use a fin comb to straighten any coil fins which were inadvertently bent during the cleaning process.

## Microchannel Condenser Coil Repair and Replacement

If microchannel condenser coil repair or replacement is required, refer to *Unitary Light and Large Commercial Units – General Service Bulletin (RT-SVB83\*-EN)* for further details.

## Final Process

Record the unit data in the blanks provided.

**Table 39. Sample maintenance log**

Date	Current Ambient Temp F/C	Refrigerant Circuit #1					
		Compr. Oil Level	Suct. Press. Psig/kPa	Disch. Press Psig/kPa	Liquid Press Psig/kPa	Super- heat F/ C	Sub-cool F/C
		- ok - low					
		- ok - low					

**Table 39. Sample maintenance log (continued)**

Date	Current Ambient Temp F/C	Refrigerant Circuit #1					
		Compr. Oil Level	Suct. Press. Psig/kPa	Disch. Press Psig/kPa	Liquid Press Psig/kPa	Super- heat F/ C	Sub-cool F/C
		- ok - low					
		- ok - low					
		- ok - low					
		- ok - low					
		- ok - low					
		- ok - low					
		- ok - low					
		- ok - low					
		- ok - low					
		- ok - low					
		- ok - low					
		- ok - low					
		- ok - low					
		- ok - low					
		- ok - low					
		- ok - low					
		- ok - low					

## Fall Restraint

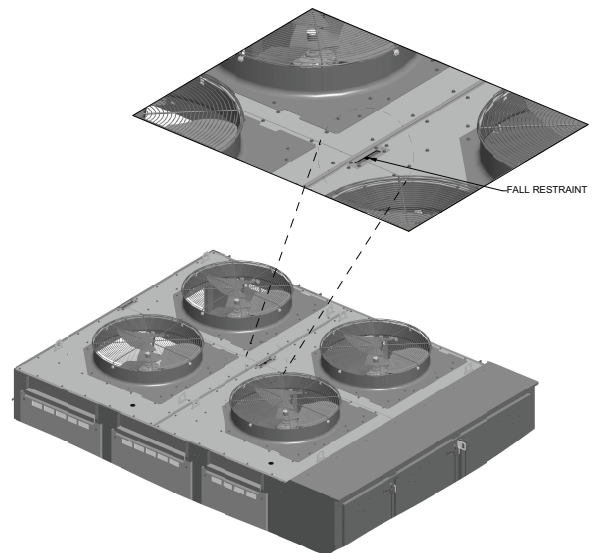
### ⚠ WARNING

#### Falling Off Equipment!

Failure to follow instructions below could result in death or serious injury.

This unit is built with fall restraint slots located on unit top that **MUST** be used during servicing. These slots are to be used with fall restraint equipment that will not allow an individual to reach the unit edge. However such equipment will **NOT** prevent falling to the ground, as they are **NOT** designed to withstand the force of a falling individual.

The fall restraint is located approximately 3 feet from the unit edge.

**Figure 67. Fall restraint**




## Refrigeration System

### **⚠ WARNING**

#### **Risk of Fire — Flammable Refrigerant!**

Failure to follow instructions below could result in death or serious injury, and equipment damage.

- To be repaired only by trained service personnel.
- Do not puncture refrigerant tubing.
- Dispose of properly in accordance with federal or local regulations.

### **⚠ WARNING**

#### **Refrigerant under High Pressure!**

Failure to follow instructions below could result in an explosion which could result in death or serious injury or equipment damage.

System contains refrigerant under high pressure. Recover refrigerant to relieve pressure before opening the system. See unit nameplate for refrigerant type. Do not use non-approved refrigerants, refrigerant substitutes, or refrigerant additives.

### **⚠ WARNING**

#### **Hazardous Voltage!**

Failure to disconnect power before servicing could result in death or serious injury.

Disconnect all electric power, including remote disconnects before servicing. Follow proper lockout/tagout procedures to ensure the power can not be inadvertently energized. Verify that no power is present with a voltmeter.

## Refrigerant Evacuation and Charging

### **NOTICE**

#### **Compressor Damage!**

Failure to follow instructions below result in permanent damage to the compressor.

The unit is fully charged with R-454B refrigerant from the factory. However, if it becomes necessary to remove or recharge the system with refrigerant, it is important that the following actions are taken.

**Important:** Do Not release refrigerant to the atmosphere! If adding or removing refrigerant is required, the service technician must comply with all federal, state, and local laws.

- To prevent cross contamination of refrigerants and oils, use only dedicated R-454B service equipment.
- Disconnect unit power before evacuation and do not apply voltage to compressor while under vacuum. Failure to follow these instructions will result in compressor failure.
- Due to the presence of POE oil, minimize system open time. Do not exceed 1 hour.
- When recharging R-454B refrigerant, it should be charged in the liquid state.
- The compressor should be off when the initial refrigerant recharge is performed.
- Charging to the liquid line is required prior to starting the compressor to minimize the potential damage to the compressor due to refrigerant in the compressor oil sump at startup.
- If suction line charging is needed to complete the charging process, only do so with the compressor operating. Do not charge liquid refrigerant into the suction line with the compressor off! This increases both the probability that the compressor will start with refrigerant in the compressor oil sump and the potential for compressor damage.
- Allow the crankcase heater to operate a minimum of 8 hours before starting the unit.

## Charge Storage

Due to the reduced capacity of the microchannel condenser coil compared to the round tube plate fin evaporator coil, pumping refrigerant into the condenser coil to service the refrigerant system is no longer an option.

## Compressor Oil

If a motor burn out is suspected, use an acid test kit to check the condition of the oil. Test results will indicate an acid level has exceeded the limit if a burn out occurred. Oil test kits must be used for POE oil (OIL00079 for a quart container or OIL00080 for a gallon container) to determine whether the oil is acid.

If a motor burn out has occurred, change the oil in both compressors in a tandem set. This will require that the oil equalizer tube be removed to suck the oil out of the oil sump. A catch pan must be used to catch the oil when the compressor oil equalizer line is loosened.

**Note:** Refrigerant oil is detrimental to some roofing materials. Care must be taken to protect the roof from oil leaks or spills.

Charge the new oil into the Schrader valve on the shell of the compressor. Due to the moisture absorption properties of POE oil, do not use POE oil from a previously opened container. Also discard any excess oil from the container that is not used.

Compressor model	Oil amount
CSHE071-088	6.4 pts
CSHE097-152	7.0 pts
CSHE177	7.6 pts

## Compressor Replacements

### Electrical Phasing

If it becomes necessary to replace a compressor, it is very important to review and follow the Electrical Phasing procedure described in the startup procedure of this manual.

If the compressors are allowed to run backward for even a very short period of time, internal compressor damage may occur and compressor life may be reduced. If allowed to run backwards for an extended period of time the motor windings can overheat and cause the motor winding thermostats to open. This will cause a “compressor trip” diagnostic and stop the compressor.

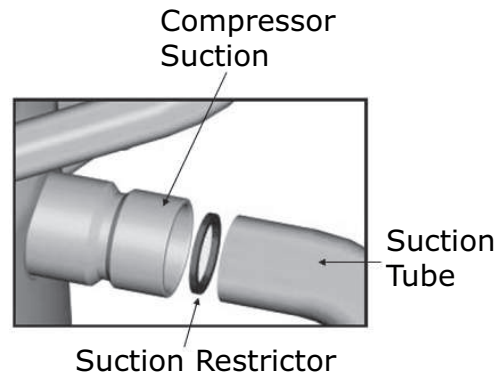
If a scroll compressor is rotating backwards, it will not pump and a loud rattling sound can be observed. Check the electrical phasing at the compressor terminal box. If the phasing is correct, before condemning the compressor, interchange any two leads to check the internal motor phasing.

### Precision Suction Restrictor

Manifolded compressors that have unequal capacity sizes use a precision suction restrictor to balance the oil levels in the compressors (see figure below). This restrictor is placed in the smaller capacity compressor. When replacing this compressor, it is imperative that the proper restrictor is selected from those provided with the replacement compressor.

When the compressors are restarted, verify that correct oil levels are obtained with both compressors operating.

**Figure 68. Precision suction restrictor**

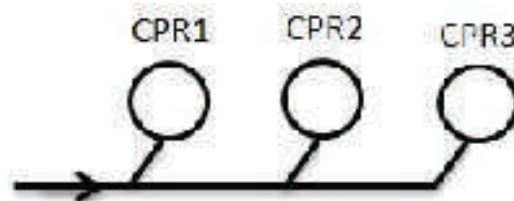


**Table 40. Compressor restrictor location**

Model	Efficiency	Restrictor Location		
		CPR 1	CPR2	CPR 3
TC/TE/YC*275 and 330	High and Std	X		
TC/TE/YC*305 and 360	High and Std	X		
TC/TE/YC*350 and 420	High and Std			
TC/TE/YC*400 and 480	High and Std	X		
TC/TE/YC*500 and 600	High and Std	X		

**Figure 69. Compressors**

## 27.5-50 Tons Standard and High Efficiency



## VFD Programming Parameters (Supply)

Units shipped with an optional variable frequency drive (VFD) are preset and run tested at the factory. If a problem with a VFD occurs, ensure that the programmed parameters listed in [Table 41, p. 92](#) have been set before replacing the drive.

### Verify Parameters

Verify parameter 1-23 is set to 60 Hz (or 50 Hz where

applicable) and that parameter 0-06 is set to the correct supply voltage/frequency range.

1. To check parameter 1-23 press the Main Menu button twice (if TR150 drive) (press the Back button if the main menu does not display)
2. Scroll down to Load & Motor, press OK
3. Select 1-2, press OK
4. Press down until parameter 1-23 is displayed. Parameter 1-23 can then be modified by pressing OK and pressing the Up and Down buttons.
5. When the desired selection has been made, press OK .

Should replacing the VFD become necessary, the replacement is not configured with all of Trane's operating parameters. The VFD must be programmed before attempting to operate the unit.

To verify and/or program a VFD, use the following steps:

1. To modify parameters:
  - a. Press Main Menu twice (if TR150 drive) (press Back if the main menu does not display)
  - b. Use the Up and Down buttons to find the parameter menu group (first part of parameter number)
  - c. Press OK
  - d. Use the Up and Down buttons to select the correct parameter sub-group (first digit of second part of parameter number)
  - e. Press OK
  - f. Use the Up and Down buttons to select the specific parameter
  - g. Press OK
  - h. To move to a different digit within a parameter setting, use the Left and Right buttons (Highlighted area indicates digit selected for change)
  - i. Use the Up and Down buttons to adjust the digit
  - j. Press Cancel to disregard change, or press OK to accept change and enter the new setting
2. Repeat previous step for each menu selection setting in [Table 41, p. 92](#).
3. To reset all programming parameters back to default:
  - a. Go to parameter 14-22 Operation Mode
  - b. Press OK
  - c. Select Initialization
  - d. Press OK
  - e. Cut off the mains supply and wait until the display turns off.
  - f. Reconnect the mains supply - the frequency converter is now reset.
  - g. Ensure parameter 14-22 Operation Mode has reverted back to "Normal Operation".

**Notes:**

- *Item 3 resets the drive to the default factory settings. The program parameters listed in [Table 41, p. 92](#) will need to be verified or changed as described in Items 1 and 2.*
- *Some of the parameters listed in the table are motor specific. Due to various motors and efficiencies available, use only the values stamped on the specific motor nameplate. Do not use the Unit nameplate values.*
- *A backup copy of the current setup may be saved to the LCP before changing parameters or resetting the drive using parameter 0-50 LCP Copy (All to LCP to save all parameters to keypad and All from LCP to download all parameters into drive/replacement drive).. See LCP Copy in the VFD Operating Instructions for details.*

4. Follow the start-up procedures for supply fan in the "Variable Air Volume System" section.
5. After verifying that the VFD(s) are operating properly, press the STOP key to stop the unit operation.
6. Follow the applicable steps in the "Final Unit Checkout" section to return the unit to its normal operating mode.

If a problem with a VFD occurs, ensure that the programmed parameters listed for supply VFD have been set before replacing the drive.



## Maintenance

**Table 41. Relief/return fan VFD parameters**

Menu	ID	Name	FC	Unit
Operation/Display	0-01	Language	English US	
	0-03	Regional Settings	North America	
	0-06 (TR150 only)	Grid Type	Set to applicable unit power supply 200-240V/60Hz for 200 & 230V/60Hz units; 440-480V/60Hz for 460V/60Hz units; 525-600V/60Hz for 575V/60Hz units; 380-440V/50Hz for 380 & 415V/50Hz supply. For IT Grid (no ground connections) or corner-grounded Delta power supply systems, select the applicable voltage/Hz and IT-Grid or Delta.	
	0-20 (TR200 only)	Display Line 1.1 Small	Analog Input 53	
	0-22 (TR200 only)	Display Line 1.3 Small	Input Power [hp]	
	0-40	[Hand on] Key on LCP	Disabled	
Load and Motor	1-03	Torque Characteristics	Variable Torque	
	1-20 (TR150)1-21 (TR200)	Motor Power [HP]	Per Motor Nameplate HP	hp
	1-22	Motor Voltage	Per Motor Nameplate Voltage	V
	1-23	Motor Frequency	Per Motor Nameplate	Hz
	1-24	Motor Current	Per Motor Nameplate FLA	A
	1-25	Motor Nominal Speed	Per Motor Nameplate Rated Speed	RPM
	1-39	Motor Poles	4	
	1-73	Flying Start	Enabled	
	1-90	Motor Thermal Protection	ETR Trip1	
Brakes	2-00	DC Hold/Preheat Current	0	%
	2-01	DC Brake Current	0	%
	2-04	DC Brake Cut In Speed [Hz]	10	Hz
Reference / Ramps	3-03	Maximum Reference	60	Hz
	3-16	Reference 2 Source	No function	
	3-17	Reference 3 Source	No function	
	3-41	Ramp 1 Ramp up Time	30	s
	3-42	Ramp 1 Ramp Down Time	30	s
Limits / Warnings	4-12	Motor Speed Low Limit [Hz]	35	Hz
	4-14	Motor Speed High Limit [Hz]	60	Hz
	4-18	Current Limit	100	%
	4-19	Max Output Frequency	60	Hz
Digital In/Out	5-12	Terminal 27 Digital Input	Coast inverse	
	5-13	Terminal 29 Digital Input	No operation	
	5-40	Function Relay	Relay 1 active No alarm, Relay 2 active Motor Running (Relay 1 [160], Relay 2 [5])	

**Table 41. Relief/return fan VFD parameters (continued)**

Menu	ID	Name	FC	Unit
Analog In/Out	6-14	Terminal 53 Low Ref./Feedb. Value	35	
	6-15	Terminal 53 High Ref./Feedb. Value	60	
Special Function	14-01	Switching Frequency	8.0 kHz (drive dependant, set to 5kHz if 8kHz not available)	
	14-11 (TR200 only)	Mains Voltage at Mains Fault	391V for 460V 60Hz unit, leave at default otherwise	
	14-12	Function at Mains Imbalance	Derate	
	14-20	Reset Mode	Automatic reset x 5	
	14-27	Action at Inverter Fault	Warning	
	14-50	RFI Filter	Off	
	14-60 (TR200 only)	Function at Over Temperature	Derate	
14-61 (TR200 only)	Function at Inverter Overload	Derate		

**Note:** For 50Hz units parameters 0-06 Grid Type (TR150s only) and 1-23 Motor Freq will need to be set accordingly.



# Diagnostics

For diagnostic information, see Symbio™ 700 Controller with Voyager 3 Packaged Rooftop Air-Conditioners

Application Guide (BAS-APG048\*-EN).



# Troubleshooting

The current alarms and alarm history can be reviewed to help determine probable cause when troubleshooting "Probable Cause" in the table below. The Symbio 700 local

user interface can be used to review the active alarms. The Symbio mobile app provides the ability to review current alarms and alarm history.

**Table 42. Troubleshooting**

Symptom	Probable Cause	Recommended Action
A. Unit will not operate. No Heat, No Cool or No Fan operation.	1. No power to the Unit.	1. Check line voltage at service disconnect.
	2. No power to the Symbio™ 700.	2. See Symbio™ 700 Controller with Voyager 3 Packaged Rooftop Air Conditioners (BAS-APG048*-EN) for Symbio 700 troubleshooting details.
	3. Zone Sensor Module (ZSM) is defective or MODE circuit is open. (VAV only)	3. See Zone Sensor Module (ZSM) Test Procedures or short MODE input on VAV units.
	4. Symbio™ 700 is defective.	4. See Symbio™ 700 Controller with Voyager 3 Packaged Rooftop Air Conditioners (BAS-APG048*-EN) for Symbio 700 troubleshooting details.
	5. Symbio 700 User Interface shows "Diagnostic: VFD Supply Fan Broken Belt – 1".	5. Check the IDM and belts, replace as necessary.
	6. Emergency Stop input is active.	6. Check the Emergency Stop input.
	7. Symbio™ 700 Stop Source active.	Check the "Unit Stop Source" point value in local UI or Symbio mobile app.
B. CPRs will not operate. Indoor fan is running continuously.	1. Unit is operating in "Refrigerant Mitigation Active" as a response to the Leak Detection System.	1. Verify there is a "Diagnostic Refrigerant Concentration Sensor A" alarm is active on the Symbio™ 700 local UI or Symbio mobile application. If so, check the refrigeration system for a refrigerant leak.
	2. Refrigerant leak detection sensor failure causes the unit to operate in "Refrigerant Mitigation Active".	2. Verify there is a "Refrigerant Leak Sensor Failure Sensor A" active alarm on the Symbio™ 700 local UI or Symbio mobile application. If so, possible replacement of the refrigeration detection sensor may be required.  Verify value of point "Refrigerant Leak Sensor Communication Status Sensor A". - If value is 3= communicating, no communication issues exist. - If value is 2= Not communicating, check wiring between the sensor and the Symbio 700 connection point.
	3. Froststat switch failure (failed open).	3. Replace Froststat switch.
<b>SZ VAV Units only</b>		
C. Unit will not Heat or Cool, but the Fan switch operates.	1. Zone Sensor Module (ZSM) is defective.	1. Refer to the Zone Sensor Module (ZSM) Test Procedures.
	2. Problem in (ZSM) wiring.	2. Disconnect the ZSM wiring at Symbio™ 700 and test the wires using the Zone Sensor Test Procedures to locate any wiring problems.
	3. Symbio™ 700 is defective.	3. See Symbio™ 700 Controller with Voyager 3 Packaged Rooftop Air Conditioners (BAS-APG048*-EN) for Symbio 700 troubleshooting details.
<b>SZ VAV or VAV (Unoccupied)</b>		
D. Unit heats and cools, but will not control to set point.	1. Zone Sensor Module (ZSM) is defective.	1. Refer to the Zone Sensor Module (ZSM) Test Procedures.Refer to the Default Chart.
	2. Thermometer on the ZSM out of calibration.	2. Check and calibrate the thermometer.
E. CPRs will not operate, ODMs will operate.	1. Compressor failure.	1. Test compressor, mechanically and electrically. Replace if necessary.
	2. Wiring, terminal, or mechanical contactor failure.	2. Check wires, terminals, and compressor contactors. Repair or replace if necessary.
	3. LPC1 has tripped.	3. Leak check, repair, evacuate and recharge as necessary. Check LPC1 operation.
	4. Symbio™ 700 or Adapter Board is defective.	4. Check output voltage to compressor contactors on Adapter Board J5.

## Troubleshooting

**Table 42. Troubleshooting (continued)**

Symptom	Probable Cause	Recommended Action
F. CPRs operates, ODMs will not operate.	1. ODM has failed.	1. Check ODM's, replace if necessary.
	2. Wiring, terminal, or mechanical contactor failure.	2. Check wires, terminals, and compressor contactor. Repair or replace if necessary.
	3. ODF 20 or 34 relay has failed.	3. Check for proper voltage and contact closure. ODF20 and 34 have a 24 VAC holding Coil. If voltage is present, replace relay.
	4. Symbio™ 700 or Adapter Board is defective.	4. See Symbio™ 700 Controller with Voyager 3 Packaged Rooftop Air Conditioners (BAS-APG048*-EN) for Symbio 700 troubleshooting details.
G. CPRs and ODMs will not operate.	1. No power to compressor contactor coil. Possible Cool Failure	1. Check wiring, terminals and applicable controls (HPCs, DTLs, LPC)
	2. Compressor contactor coil defective. Cool Failure Indicated.	2. Check compressor contactor coil. If open or shorted, replace compressor contactor.
	3. Compressor contactor contacts defective.	3. If 24 VAC is present at compressor contactor coil, verify contact closure.
	4. Symbio™ 700 or Adapter Board is defective.	4. See Symbio™ 700 Controller with Voyager 3 Packaged Rooftop Air Conditioners (BAS-APG048*-EN) for Symbio 700 troubleshooting details.
	5. LPC1 has tripped	5. Leak check, repair, evacuate, and recharge as necessary. Check LPCs operation.
H. ODM 3 and/or 4 will not cycle.	1. OAS has failed.	1. Perform OAS Resistance/Temperature check. Replace if necessary.
	2. Wiring, terminal, or OFC3 contactor failure.	2. Check wires, terminals, and OFC3. Repair or replace if necessary.
	3. ODM3 and/or 4 has failed.	3. Check ODM, replace if necessary.
	4. Symbio™ 700 or Adapter Board is defective.	4. See Symbio™ 700 Controller with Voyager 3 Packaged Rooftop Air Conditioners (BAS-APG048*-EN) for Symbio 700 troubleshooting details.
	5. ODF20 has failed.	5. Check for proper voltage and contact closure. ODF20 relay has a 24 VAC holding coil. If voltage is present, replace relay.
I. Indoor motor (IDM) will not operate	1. IDM has failed.	1. Check IDM, replace if necessary.
	2. Wiring, terminal, fuses, or contactor failure.	2. Check wiring, terminals, fuses, and contactor assembly. Repair or replace wiring, terminals, fuses or fan contactor assembly.
	3. ZSM is defective.	3. Place unit in test mode. If the fan operates in the test mode, test the ZSM using the appropriate test procedures.
	4. Symbio™ 700 is defective.	4. See Symbio™ 700 Controller with Voyager 3 Packaged Rooftop Air Conditioners (BAS-APG048*-EN) for Symbio 700 troubleshooting details.
	5. Supply fan proving diagnostic has been enunciated.	5. Check Symbio™ 700 user interface and VFD for Broken Belt diagnostics. Replace belt if necessary.
J. No Heat (YC's only) CFM will not run, igniter sparks, GV is energized	1. CFM has failed.	1. Check CFM, replace if necessary.
	2. CFM capacitor has failed.	2. Disconnect BROWN wires from capacitor, test, and replace if necessary.
	3. Wiring, or terminal failure.	3. Check wiring, and terminals. Repair, or replace if necessary.
	4. TNS3 and/or 4 has failed. (460/575 V units only)	4. Check for 230 VAC at TNS3 and/or 4 secondary, between Y1 and Y2. If 230 VAC is not present, replace TNS3 and/or 4.
	5. Modulating gas is not configured properly.	5. Check VB1285 wiring and ID plug version.
K. No Heat (YC's only) CFM runs, GV energizes, igniter does not spark.	1. Flame sense rod has failed.	1. Check for continuity between rod and ground and replace flame sense rod if no continuity.
	2. Wiring or terminal failure.	2. Check wiring and terminals. Repair or replace if necessary.
	3. Spark igniter has failed.	3. Spark igniter should fire when heat is called for and 155VAC is applied. If no spark, replace igniter.
	4. High temp limit switch has failed.	4. Check for continuity across high temp limit switch and replace if no continuity.



**Table 42. Troubleshooting (continued)**

Symptom	Probable Cause	Recommended Action
L. No Heat (YC's only) GV does not energize, CFM runs, igniter sparks.	1. Wiring or terminal failure.	1. Verify presence of 24 VAC between IGN J1-7 terminal to ground, if not present, check wiring and terminals. Repair or replace if necessary.
	2. GV has failed.	2. Measure voltage between TH and TR on the gas valve (GV). If 24 VAC is present and the GV will not open, replace the GV.
	3. Pressure switch failure.	3. Verify input gas pressure is not below minimum set on low gas pressure switch.
M. No Heat (TE's only) Electric heat will not operate.	1. Heater contactor(s) have failed.	1. Check for 24 VAC at electric heat, and DH contactor coils. If 24 VAC is present on a call for heat, and the contacts do not close, the contactor has failed.
	2. Heater element temperature limit(s) is open.	2. Check line voltage between the element temperature limit terminals located in heat section. If line voltage is present, the limit is open. Repair heating unit, or replace limit(s) as needed.
	3. Wiring or terminal failure.	3. Check for wiring or terminal failure in control and power circuit. Repair or replace if necessary.
	4. Heater Element(s) has failed.	4. Check element and circuit integrity. Repair or replace as necessary. Replace open elements.
	5. Symbio™ 700 control system is defective.	See Symbio™ 700 Controller with Voyager 3 Packaged Rooftop Air Conditioners (BAS-APG048*-EN) for Symbio 700 troubleshooting details.
N. Evaporator coil freezes up during low ambient operation.	1. System low on refrigerant charge.	1. Leak check, repair, evacuate, and recharge system as necessary.
	2. System low on air flow.	2. Check return air for obstruction or dirty filters. Check fan wheels, motors, and belts.
	3. Outdoor Air Sensor (OAS) has Failed.	3. Check OAS resistance at connector P15. Refer to the Resistance versus Temperature chart. Replace sensor if necessary.
	4. Froststat™ has Failed	4. Check Froststat Switch
O. Economizer will not operate.	1. Economizer connector not plugged into unit wiring harness.	1. Check connector, and connect if necessary.
	2. Economizer Actuator (ECA) has failed.	2. Verify that 24 VAC is present between ECA terminals 24 VAC and Common. Place the unit in econ test mode; economizer actuator should drive open. In any other unit test mode, economizer actuator should drive to minimum position. If ECA does not drive as specified, replace ECA.
	3. Wiring or terminal failure.	3. Check wiring, Fresh Air Options module, and terminals. Repair or replace if necessary.
	4. ECA is defective.	4. Perform the ECA Test Procedures discussed previously.
P. Minimum position is at zero, cannot be adjusted. Economizer still modulates.	1. Remote Minimum position potentiometer has failed.	1. With the main power off, check the resistance between terminals on J8 at the Customer Connection Module by rotating the remote minimum position potentiometer knob. Resistance should be 50 to 200 Ohms.
Q. Economizer goes to minimum position, and will not modulate.	1. OAS has failed.	1. Check the OAS at connector P8 by disconnecting P8 from J8 on the RTRM. Check resistance between P8-1 and P8-2, refer to the Resistance versus Temperature Chart. Replace sensor if necessary.
	2. DAS has failed.	2. Check the DAS at connector P14 of the Symbio™ 700 module. Check for resistance on P14 of the Symbio™ 700 module, refer to the Resistance versus Temperature Chart. Replace sensor if necessary.
R. Economizer modulates, but system does not seem to operate as efficiently as in the past.	1. Comparative enthalpy setup, RAS or RHS failed. System is operating using Reference enthalpy.	1. Check the resistance of the return air sensor (RAS) at connector P9 on the Fresh Air Module. Refer to the Resistance versus Temperature Chart. Replace the sensor if necessary. Check the return air humidity sensor (RHS) by measuring the operating current at terminals P9 of the Fresh Air Module. Normal operating current is 4 to 20 milliamps mA. Note: The humidity sensors are polarity sensitive, and will not operate if connected backwards.
	2. Reference enthalpy setup, OHS has failed. System is operating using dry bulb control.	2. Check the outside humidity sensor (OHS) by measuring the operating current at terminals P9 of the Fresh Air Module. Normal operating current is 4 to 20 milliamps mA.
	3. Comparative enthalpy setup, OHS has failed. System is operating using dry bulb control.	3. Perform #2 above.



## Troubleshooting

**Table 42. Troubleshooting (continued)**

Symptom	Probable Cause	Recommended Action
S. Power Exhaust will not operate.	1. Exhaust motor has failed.	1. Check the exhaust fan motor, and replace if necessary.
	2. XFR has failed.	2. Check the exhaust fan contactor (XFR). Replace if necessary
	3. ECA has failed.	3. Perform the ECA Test Procedures discussed previously.
T. VFD will not operate properly	1. Symbio™ 700 has Failed	1. See Symbio™ 700 Controller with Voyager 3 Packaged Rooftop Air Conditioners (BAS-APG048*-EN) for Symbio 700 troubleshooting details.
	2. VFD has Failure	2. Check the VFD
U. Power Exhaust Fan cycles ON/OFF	1. Space Pressure Deadband is too narrow	1. Increase the Space Pressure Deadband.
	2. Space Pressure Setpoint is too high/low	2. Verify Building Pressure with maximum building exhaust enabled. Adjust Space Pressure Setpoint accordingly.

For information on component failure diagnostics, see Symbio™ 700 Controller with Voyager 3 Packaged Rooftop Air Conditioners (BAS-APG048\*-EN).



# Unit Wiring Diagram Numbers

Schematic Type	Voltage	Diagram Number	Description
Sheet 1; Power	All	12134517	POWER - THREE COMPRESSORS (eSTAGE), 3/4 CONDENSER FANS
Sheet 2; Power		12134896	POWER - SUPPLY/EXHAUST   W/O SUPPLY FAN BYPASS
		12134897	POWER, SUPPLY/EXHAUST   W/ SUPPLY FAN BYPASS
Sheet 3; Symbio 700		12134926	CONTROLS - SYMBIO 700 UNIT CONTROLS
Sheet 4; Adapter Board		12134529	CONTROLS - ADAPTER BOARD UNIT CONTROLS  THREE COMPRESSORS (eSTAGE), 3/4 FANS
Sheet 5; Indoor Options Module		12134530	CONTROLS - INDOOR OPTIONS   W/O SUPPLY FAN BYPASS
		12134531	CONTROLS - INDOOR OPTIONS   W/ BYPASS
Sheet 6; Fresh Air Options Module		12134532	CONTROLS - FRESH AIR OPTIONS   STANDARD ECONOMIZER
		12134533	CONTROLS - FRESH AIR OPTIONS   ULTRA LOW LEAK ECONOMIZER
Sheet 7; Customer Connection Module		12134534	CUSTOMER CONNECTION OPTIONS
Sheet 8; Stepper Motor Module		12134535	REHEAT, STEPPER MOTOR CONTROLLER
Sheet 9; XM Module	12134536	EXPANSION MODULES	
Sheet 10; Heat Options	208-230V	12134520	ELECTRIC HEAT - 208/230V
	380-575V	12134521	ELECTRIC HEAT - 380-575V, 36/54kW
		12134522	ELECTRIC HEAT - 380-575V, 72/90/108kW
	Sheet 11; Heat Options	All	12134523
12134524			GAS HEAT - HEATER 1  MODULATING
12134525	GAS HEAT - HEATER 2   2-STAGE		
Device Location	12134927		COOLING/ELECTRIC HEAT   HORIZONTAL RETURN
	12134928		COOLING/ELECTRIC HEAT   DOWNFLOW RETURN
	12134925		GAS HEAT   HORIZONTAL RETURN
	12134924		GAS HEAT   DOWNFLOW RETURN
	12134554		MAIN CONTROL PANEL
	12134555		VFD PANEL
	12134556		ELECTRIC HEAT PANEL



# Warranty and Liability Clause

## COMMERCIAL EQUIPMENT - 20 TONS AND LARGER AND RELATED ACCESSORIES

PRODUCTS COVERED - This warranty\* is extended by Trane Inc. and applies only to commercial equipment rated 20 Tons and larger and related accessories.

The Company warrants for a period of 12 months from initial startup or 18 months from date of shipment, whichever is less, that the Company products covered by this order (1) are free from defects in material and workmanship and (2) have the capacities and ratings set forth in the Company's catalogs and bulletins, provided that no warranty is made against corrosion, erosion or deterioration. The Company's obligations and liabilities under this warranty are limited to furnishing f.o.b. factory or warehouse at Company designated shipping point, freight allowed to Buyer's city (or port of export for shipment outside the conterminous United States) replacement equipment (or at the option of the Company parts therefore) for all Company products not conforming to this warranty and which have been returned to the manufacturer. The Company shall not be obligated to pay for the cost of lost refrigerant. No liability whatever shall attach to the Company until said products have been paid for and then said liability shall be limited to the purchase price of the equipment shown to be defective.

The Company makes certain further warranty protection available on an optional extra-cost basis. Any further warranty must be in writing, signed by an officer of the Company.

The warranty and liability set forth herein are in lieu of all other warranties and liabilities, whether in contract or in negligence, express or implied, in law or in fact, including implied warranties of merchantability and fitness for particular use. In no event shall the Company be liable for any incidental or consequential damages.

THE WARRANTY AND LIABILITY SET FORTH HEREIN ARE IN LIEU OF ALL OTHER WARRANTIES AND LIABILITIES, WHETHER IN CONTRACT OR IN NEGLIGENCE, EXPRESS OR IMPLIED, IN LAW OR IN FACT, INCLUDING IMPLIED WARRANTIES OF MERCHANTABILITY AND FITNESS FOR PARTICULAR USE, IN NO EVENT SHALL WARRANTOR BE LIABLE FOR ANY INCIDENTAL OR CONSEQUENTIAL DAMAGES.

Manager - Product Service

Trane

Clarksville, Tn 37040-1008

PW-215-2688

A 10-year limited warranty is provided on optional Stainless Steel Gas Heat Exchanger. Electronic, burner, and other related components to the Gas Heater subassembly with a Stainless Steel Gas Heat Exchanger have a 2-year limited warranty.

\*Optional Extended Warranties are available for compressors and heat exchangers of Combination Gas-Electric Air Conditioning Units.

\*A 5 year limited warranty is provided for optional "AMCA 1A Ultra Low Leak" airfoil blade economizer assemblies and the "AMCA 1A Ultra Low Leak" economizer actuator.





**Notes**

---



Trane - by Trane Technologies (NYSE: TT), a global innovator - creates comfortable, energy efficient indoor environments for commercial and residential applications. For more information, please visit [trane.com](https://trane.com) or [tranetechnologies.com](https://tranetechnologies.com).

Trane has a policy of continuous product and product data improvements and reserves the right to change design and specifications without notice. We are committed to using environmentally conscious print practices.

RT-SVX089C-EN 21 Mar 2025  
Supersedes RT-SVX089B-EN (April 2024)

©2025 Trane