

Installation, Operation, and Maintenance

Packaged Rooftop Air

Conditioners

Precedent™ Cooling and Electric

Heat

Standard Efficiency
6 to 25 Tons – 60 Hz



Model Numbers: TSJ072A - TSJ300A

⚠ SAFETY WARNING

Only qualified personnel should install and service the equipment. The installation, starting up, and servicing of heating, ventilating, and air-conditioning equipment can be hazardous and requires specific knowledge and training. Improperly installed, adjusted or altered equipment by an unqualified person could result in death or serious injury. When working on the equipment, observe all precautions in the literature and on the tags, stickers, and labels that are attached to the equipment.

May 2023

RT-SVX070C-EN

Introduction

Read this manual thoroughly before operating or servicing this unit.

Warnings, Cautions, and Notices

Safety advisories appear throughout this manual as required. Your personal safety and the proper operation of this machine depend upon the strict observance of these precautions.

The three types of advisories are defined as follows:

⚠ WARNING Indicates a potentially hazardous situation which, if not avoided, could result in death or serious injury.

⚠ CAUTION Indicates a potentially hazardous situation which, if not avoided, could result in minor or moderate injury. It could also be used to alert against unsafe practices.

NOTICE Indicates a situation that could result in equipment or property-damage only accidents.

Important Environmental Concerns

Scientific research has shown that certain man-made chemicals can affect the earth's naturally occurring stratospheric ozone layer when released to the atmosphere. In particular, several of the identified chemicals that may affect the ozone layer are refrigerants that contain Chlorine, Fluorine and Carbon (CFCs) and those containing Hydrogen, Chlorine, Fluorine and Carbon (HCFCs). Not all refrigerants containing these compounds have the same potential impact to the environment. Trane advocates the responsible handling of all refrigerants.

Important Responsible Refrigerant Practices

Trane believes that responsible refrigerant practices are important to the environment, our customers, and the air conditioning industry. All technicians who handle refrigerants must be certified according to local rules. For the USA, the Federal Clean Air Act (Section 608) sets forth the requirements for handling, reclaiming, recovering and recycling of certain refrigerants and the equipment that is used in these service procedures. In addition, some states or municipalities may have additional requirements that must also be adhered to for responsible management of refrigerants. Know the applicable laws and follow them.

⚠ WARNING

Proper Field Wiring and Grounding Required!

Failure to follow code could result in death or serious injury.

All field wiring **MUST** be performed by qualified personnel. Improperly installed and grounded field wiring poses **FIRE** and **ELECTROCUTION** hazards. To avoid these hazards, you **MUST** follow requirements for field wiring installation and grounding as described in **NEC** and your local/state/national electrical codes.

⚠ WARNING

Personal Protective Equipment (PPE) Required!

Failure to wear proper PPE for the job being undertaken could result in death or serious injury.

Technicians, in order to protect themselves from potential electrical, mechanical, and chemical hazards, **MUST** follow precautions in this manual and on the tags, stickers, and labels, as well as the instructions below:

- **Before installing/servicing this unit, technicians MUST put on all PPE required for the work being undertaken (Examples; cut resistant gloves/sleeves, butyl gloves, safety glasses, hard hat/bump cap, fall protection, electrical PPE and arc flash clothing). ALWAYS refer to appropriate Safety Data Sheets (SDS) and OSHA guidelines for proper PPE.**
- **When working with or around hazardous chemicals, ALWAYS refer to the appropriate SDS and OSHA/GHS (Global Harmonized System of Classification and Labelling of Chemicals) guidelines for information on allowable personal exposure levels, proper respiratory protection and handling instructions.**
- **If there is a risk of energized electrical contact, arc, or flash, technicians MUST put on all PPE in accordance with OSHA, NFPA 70E, or other country-specific requirements for arc flash protection, PRIOR to servicing the unit. NEVER PERFORM ANY SWITCHING, DISCONNECTING, OR VOLTAGE TESTING WITHOUT PROPER ELECTRICAL PPE AND ARC FLASH CLOTHING. ENSURE ELECTRICAL METERS AND EQUIPMENT ARE PROPERLY RATED FOR INTENDED VOLTAGE.**

⚠ WARNING

Follow EHS Policies!

Failure to follow instructions below could result in death or serious injury.

- All Trane personnel must follow the company's Environmental, Health and Safety (EHS) policies when performing work such as hot work, electrical, fall protection, lockout/tagout, refrigerant handling, etc. Where local regulations are more stringent than these policies, those regulations supersede these policies.
- Non-Trane personnel should always follow local regulations.

Copyright

This document and the information in it are the property of Trane, and may not be used or reproduced in whole or in part without written permission. Trane reserves the right to revise this publication at any time, and to make changes to its content without obligation to notify any person of such revision or change.

Trademarks

All trademarks referenced in this document are the trademarks of their respective owners.

Revision History

Corrected unit weight table in Dimensions and Weights chapter.

Table of Contents

Model Number Description	6	Smoke Detector Sensor (Optional)	11
General Information	8	Phase Monitor	11
Unit Inspection	8	Pre-Installation	12
Exterior Inspection	8	Precautionary Measures	12
Inspection for Concealed Damage	8	First Aid Measures	12
Unit Storage	8	Dimensions and Weights	13
Unit Description	8	Dimensional Data	13
Door Handles	8	Clearances	25
Unit Nameplate	8	Weights	25
Compressor Nameplate	9	Lifting and Rigging	27
Microchannel Coil Barcode ID	9	Installation	28
LonTalk Communication Interface (Optional)	9	Horizontal Units	28
BACnet Communications Interface (Optional)	9	Ductwork	28
System Input Devices and Functions	9	Roof Curb	30
Supply Fan Failure	9	Downflow	30
Clogged Filter Switch (Optional)	9	Rigging	30
Condensate Drain Pan Overflow Switch	9	General Unit Requirements	31
Compressor Disable (CPR1/2)	9	Factory Installed Economizer	32
Low Pressure Control	10	Horizontal Discharge Conversion (6 to 12.5 Ton Units)	32
High Pressure Control	10	Return Air Smoke Detector	33
Zone Sensors	10	Air-Fi® Wireless Communication Interface	34
Manual Changeover (BAYSENS106*)	10	Main Electrical Power Requirements	34
Manual/Automatic Changeover (BAYSENS108*)	10	Electric Heat Requirements	34
Wall Mounted Relative Humidity Sensor (BAYSENS036*)	10	Low Voltage Wiring	34
Duct Mounted Relative Humidity Sensor (BAYSENS037*)	10	Condensate Drain Configuration	35
Integrated Comfort System (BAYSENS073*)	10	Filter Installation	35
Integrated Comfort System (BAYSENS074*)	10	Field Installed Power Wiring	36
Remote Zone Sensor (BAYSENS016*)	10	Main Unit Power	36
Remote Zone Sensor (BAYSENS077*)	10	Standard Wiring	36
Thermostat	10	Optional TBUE Wiring (Through-the- Base Electrical Option)	36
High Temperature Sensor (FIAHTST001*)	10	Field-Installed Control Wiring	37
Digital Display Zone Sensor (BAYSENS135*)	11	Control Power Transformer	37
Touch Screen Programmable Zone Sensor (BAYSENS800)	11	Controls using 24 Vac	37
Evaporator Frost Control	11	Controls using DC Analog Input/ Outputs (Standard Low Voltage Multi conductor Wire)	40
Discharge Line Temp Switch (DLTS)	11	DC Conductors	40
		Space Temperature Averaging	40
		Pre-Start	43
		Voltage Imbalance	43

<p>Electrical Phasing (Three Phase Motors)..... 43</p> <p>Compressor Crankcase Heaters 44</p> <p>Symbio Controls..... 44</p> <p>Unit Start-Up 46</p> <p style="padding-left: 20px;">Sequence of Operation..... 46</p> <p style="padding-left: 20px;">Return Air Smoke Detector..... 46</p> <p style="padding-left: 20px;">Compressor Start-Up 46</p> <p style="padding-left: 20px;">Hot Gas Reheat 46</p> <p style="padding-left: 20px;">Final System Setup 46</p> <p>Maintenance 48</p> <p style="padding-left: 20px;">Monthly Maintenance 48</p> <p style="padding-left: 40px;">Filters 48</p> <p style="padding-left: 40px;">Return Air Smoke Detector Maintenance 48</p>	<p>Condensate Overflow Switch 48</p> <p>Cooling Season..... 48</p> <p>Heating Season..... 48</p> <p>Coil Cleaning..... 49</p> <p>Microchannel (MCHE) Coils 49</p> <p>Annual Maintenance 51</p> <p>Final Process 51</p> <p>Troubleshooting 52</p> <p>Wiring Diagrams..... 53</p> <p>Piping Diagrams 55</p> <p>Limited Warranty 59</p> <p style="padding-left: 20px;">Electric Air Conditioner 59</p> <p style="padding-left: 40px;">TSJ Precedent Models..... 59</p>
--	---

Model Number Description

Digit 1 — Unit Function

T = DX Cooling

Digit 2 — Cooling Efficiency

S = Standard Efficiency

Digit 3 — Refrigerant

J = R-410A

Digit 4,5,6 — Nominal Gross Cooling Capacity (MBh)

072 = 6 Ton

090 = 7.5 Ton

102 = 8.5 Ton

120 = 10 Ton

150 = 12.5 Ton

180 = 15 Ton

210 = 17.5 Ton

240 = 20 Ton

300 = 25 Ton

Digit 7 — Design Sequence

Digit 8 — Voltage Selection

3 = 208–230/60/3

4 = 460/60/3

W = 575/60/3

Digit 9 — Unit Controls

S = Symbio™ 700

Digit 10 — Heat Type

0 = Base Model (None or Electric)

Digit 11 — Heating Capacity¹

0 = No Heat

C = 9 kW Electric Heat

G = 18 kW Electric Heat

K = 27 kW Electric Heat

N = 36 kW Electric Heat

P = 54 kW Electric Heat

R = 72 kW Electric Heat

Digit 12, 13 — Service Sequence

** = Factory Assigned

Digit 14 — Fresh Air Selection

0 = No Fresh Air

A = Manual Outside Air Damper 0–50%

B = Motorized Outside Air Damper 0–50%

C = Economizer, Dry Bulb 0–100% without Barometric Relief²

D = Economizer, Dry Bulb 0–100% with Barometric Relief²

E = Economizer, Reference Enthalpy 0–100% without Barometric Relief²

F = Economizer, Reference Enthalpy 0–100% with Barometric Relief²

G = Economizer, Comparative Enthalpy 0–100% without Barometric Relief²

H = Economizer, Comparative Enthalpy 0–100% with Barometric Relief²

K = Downflow Low Leak Economizer, Dry Bulb with Barometric Relief²

M = Downflow Low Leak Economizer, Reference Enthalpy with Barometric Relief²

P = Downflow Low Leak Economizer, Comparative Enthalpy with Barometric Relief²

R = Downflow Low Leak Economizer, Differential Dry Bulb with Barometric Relief²

Digit 15 — Supply Fan/Motor

0 = Multi-Speed Motor

1 = Optional Oversized/High Static Motor

2 = Single Zone Variable Air Volume with Standard Motor

3 = Single Zone Variable Air Volume with Oversized/High Static Motor

4 = Multiple Zone Variable Air Volume with Standard Motor

5 = Multiple Zone Variable Air Volume with Oversized/High Static Motor

Digit 16 — Hinged Access/Filters

0 = Standard Panels/Standard Filters

A = Hinged Access Panels/Standard Filters

B = Standard Panels/2 inch MERV 8 Filters

C = Hinged Access Panels/2 inch MERV 8 Filters

D = Standard Panels/2 inch MERV 13 Filters

E = Hinged Access Panels/2 inch MERV 13 Filters

Digit 17 — Coil Protection

0 = Standard Coil

1 = Condenser with CompleteCoat™

Digit 18 — Through-the-Base Provisions

0 = No Through-the-Base Provisions

A = Through-the-Base Electric

Digit 19 — Disconnect/Circuit Breaker (three-phase only)

0 = No Disconnect/No Circuit Breaker

1 = Unit Mounted/Non-Fused Disconnect

2 = Unit Mounted Circuit Breaker

Digit 20— Convenience Outlet

0 = No Convenience Outlet

A = Unpowered 20A Convenience Outlet

B = Powered 15A Convenience Outlet (three-phase only)

Digit 21— Communications Options

0 = No Communications Interface

1 = Advanced Controller with BACnet® Communications Interface

2 = Advanced Controller with LonTalk® Communications Interface

3 = Advanced Controller with Air-Fi® Communications Interface

Digit 22— Refrigeration System Option

0 = Standard Refrigeration System

A = Dehumidification Option^{1, 3}

Digit 23— Controls Expansion Module

0 = None

1 = XM-30 Expansion Module

2 = XM-32 Expansion Module

3 = XM-30 and XM-32 Expansion Module

4 = XM-30 Expansion Module (Qty 2)

5 = XM-32 Expansion Module (Qty 2)

Digit 24— Smoke Detector

0 = No Smoke Detector

A = Return Air Smoke Detector²

B = Supply Air Smoke Detector¹

C = Supply and Return Air Smoke Detectors^{1, 2}

Digit 25— System Monitoring Controls

- 0 = No Monitoring Control
- 1 = Clogged Filter Switch²
- 2 = Condensate Overflow Switch¹
- 3 = Discharge Air Sensing Tube
- 4 = Clogged Filter Switch and Condensate Overflow Switch^{1, 2}
- 5 = Clogged Filter Switch and Discharge Air Sensing Tube²
- 6 = Condensate Overflow Switch and Discharge Air Sensing Tube¹
- 7 = Clogged Filter Switch, Condensate Overflow Switch and Discharge Air Sensing Tube^{1, 2}

Digit 26— Not Used

Digit 27— Hardware Enhancements

- 0 = No Enhancements
- 1 = Stainless Steel Drain Pan

Digit 28— Short Circuit Current Rating

- 0 = Standard (5k) SCCR Marking
- A = Tier 2 (=65K) SCCR Marking

Digit 29— Low Ambient⁴

- 0 = None
- A = Low Ambient Cooling to 0°F

Model Number Notes

Notes:

1. Includes Symbio™ Indoor Module.
2. Includes Symbio™ Fresh Air Module.
3. Includes Symbio™ Customer Connection Module.
4. Standard Low Ambient Cooling Limit is 40°F.

General Information

Unit Inspection

To protect against loss due to damage incurred in transit, perform inspection immediately upon receipt of the unit. Check carefully for shipping damage. If any damage is found, report it immediately, and file a claim against the transportation company.

Exterior Inspection

If the job site inspection reveals damage or material shortages, file a claim with the carrier immediately. Specify the type and extent of the damage on the bill of lading before signing. Notify the appropriate sales representative.

Important: Do not proceed with installation of a damaged unit without sales representative approval.

- Inspect the complete exterior for signs of shipping damages to unit or packing material.
- Verify that the nameplate data matches the sales order and bill of lading.
- Verify that the unit is properly equipped and there are no material shortages.
- Verify the power supply complies with the unit nameplate specifications.

Inspection for Concealed Damage

Inspect the components for concealed damage as soon as possible after delivery and before it is stored.

If concealed damage is discovered:

- Notify the carrier's terminal of the damage immediately by phone and by mail.
- Concealed damage must be reported within 15 days.
- Request an immediate, joint inspection of the damage with the carrier and consignee.
- Stop unpacking the unit.
- Do not remove damaged material from receiving location.
- Take photos of the damage, if possible.
- The owner must provide reasonable evidence that the damage did not occur after delivery.

Unit Storage

Take precautions to prevent condensate from forming inside the unit's electrical compartments and motors if:

- The unit is stored before it is installed; or,
- The unit is set on the roof curb, and temporary heat is provided in the building. Isolate all side panel service entrances and base pan openings (e.g., conduit holes, S/A and R/ A openings, and flue openings) from the ambient air until the unit is ready for start-up.

Note: Do not use the unit's heater for temporary heat without first completing the start-up.

The manufacturer will not assume any responsibility for equipment damage resulting from condensate accumulation on the unit's electrical and/or mechanical components.

Unit Description

Before shipment, each unit is leak tested, dehydrated, charged with refrigerant and compressor oil, and run tested for proper control operation.

The condenser coils are all aluminum microchannel.

Direct-drive, vertical discharge condenser fans are provided with built-in thermal overload protection.

All units come with standard Symbio™ 700 control system with advanced diagnostics.

Door Handles

Door handles rotate 180 degrees for use on either left- or right-handed doors. Handles will be in the vertical position when latched, as shown in the following figure.

Figure 1. Door handles

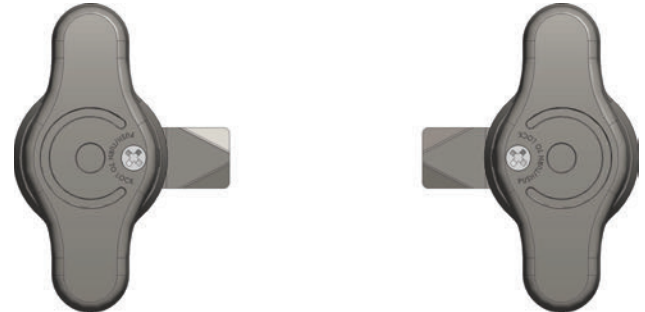

To lock:

1. Verify handle is in the vertical (latched) position.
2. Using a Phillips head screwdriver, push and rotate the handle screw clockwise 1/4 turn.

To unlock:

Use a Phillips head screwdriver to push and rotate handle screw counterclockwise 1/4 turn.

Unit Nameplate

A Mylar unit nameplate is located on the unit's corner support next to the filter access panel. It includes the unit model number, serial number, electrical characteristics, refrigerant charge, as well as other pertinent unit data.

Compressor Nameplate

The nameplate for the compressors are located on the side of the compressor.

Microchannel Coil Barcode ID

Barcode decal used for coil part identification can be located on the header and top of coil's inlet/outlet side.

LonTalk Communication Interface (Optional)

The Symbio™ controllers supports communication with LonTalk® open protocol applications. An advanced license is required to enable this feature. The LonTalk module is available factory supplied or as a field-installed kit. For more details, refer to *LonTalk® Integration to Precedent™ Packaged Rooftop Air-Conditioners with Symbio™ 700 Controls Integration Guide* (BAS-SVP063*-EN).

BACnet Communications Interface (Optional)

The Symbio™ controller provides integrated communication with BACnet® open protocol applications. An advanced license is required to enable this feature. When enabled, the following selections are available: BACnet MS/TP, BACnet IP, or BACnet Zigbee® (Air-Fi®). For more details, refer to *BACnet® and Modbus™ Integration to Precedent™ Packaged Rooftop Air-Conditioners with Symbio™ 700 Controls Integration Guide* (BAS-SVP062*-EN).

System Input Devices and Functions

The Symbio™ 700 controller requires a zone sensor or thermostat input to operate the unit in a CVZT or VVZT configuration.

Note: *Use of a conventional thermostat will reduce unit functionality.*

The number of available modes depends on the type of zone sensor or thermostat selected. Descriptions of the basic input devices used with the Symbio 700 network are provided to acquaint the operator with the various modules. Refer to the unit schematic for specific module connections. The following controls are available from the factory for field installation.

Supply Fan Failure

Supply Fan Proving is active when the Supply Fan is commanded ON. The supply fan speed must be greater than 30 rpm for 40 continuous seconds. If the supply fan speed falls below 30 rpm, supply fan failure diagnostic is generated, and operation is stopped.

Clogged Filter Switch (Optional)

The unit mounted clogged filter switch monitors the pressure differential across the return air filters. It is mounted in the filter section and is connected to the Fresh Air Options Module. A diagnostic signal is sent to the controller if the pressure differential across the filters is at least 0.5 inch w.c. The contacts will automatically open when the pressure differential across the filters decreases to approximately 0.4 inch w.c. The clogged filter output is energized when the supply fan is operating and the clogged filter switch has been closed for at least 2 minutes. The system will continue to operate regardless of the status of the filter switch. For further details, refer to Installation Instructions ACC-SVN238*-EN.

Note: *On units equipped with factory installed MERV 13 filters, a clogged filter switch with different pressure settings will be installed. This switch will close when the differential pressure is approximately 0.8 inch w.c. and open when the differential falls to 0.7 inch w.c.*

Condensate Drain Pan Overflow Switch

A condensate overflow condition will be detected by a condensate overflow float switch. When the condensate level reaches the trip point, the diagnostic condition will be detected. When the condensate overflow input CLOSES for six continuous seconds, the following actions will be taken by the Symbio™ 700 controls:

- An auto-reset diagnostic will be generated. All compressor or heating operations will be disabled immediately. Condenser fans and compressors will be de-energized. Supply fan operation will be shutdown.
- Once the overflow condition has been cleared and the input is OPEN for six seconds, all diagnostic conditions will be cleared. The unit will return to normal operation. Auto-reset clearing will occur twice each time the unit is powered up. On the third occurrence, the unit will initiate a lock-out and require manual reset. If an auto-reset overflow occurs once, but does not occur again for 72 hours, the trip counter will reset allowing more auto-resets to occur.

Compressor Disable (CPR1/2)

This input incorporates the low pressure control (LPC) of each refrigeration circuit.

If this circuit is open before the compressor is started, the compressor will not be allowed to operate. Anytime this circuit is opened for one continuous second during compressor operation, the compressor for that circuit is immediately turned OFF. The compressor will not be allowed to restart for a minimum of three minutes should the contacts close.

If four consecutive open conditions occur during the first three minutes of operation, the compressor for that circuit will be locked out, a diagnostic communicated to the remote panel (if installed), and a manual reset will be required to restart the compressor.

Low Pressure Control

When the LPC is opened for 1 continuous second, the compressor for that circuit is turned off immediately. The compressor will not be allowed to restart for a minimum of 3 minutes.

If four consecutive open conditions occur during an active call for cooling, the compressor will be locked out, a diagnostic generated, if applicable, and a manual reset required to restart the compressor.

High Pressure Control

The high pressure controls are wired in series between the compressor outputs on the Symbio™ controller and the compressor contactor coils. If the high pressure control switch opens, the controller senses a lack of current while calling for cooling and locks the compressor out.

If four consecutive open conditions occur during an active call for cooling, the compressor will be locked out, a diagnostic generated, if applicable, and a manual reset required to restart the compressor.

Zone Sensors

Manual Changeover (BAYSENS106*)

This sensor features three system switch settings (Heat, Cool, and Off) and two fan settings (On and Auto). It is a manual changeover control with single setpoint.

Manual/Automatic Changeover (BAYSENS108*)

This sensor features four system switch settings (Heat, Cool, Auto, and Off) and two fan settings (On and Auto). It is a manual or auto changeover control with dual setpoint capability. It can be used with a remote zone temperature sensor BAYSENS077*.

Wall Mounted Relative Humidity Sensor (BAYSENS036*)

Field installed, wall mounted humidity sensor that measures temperature and relative humidity. Relative humidity input is used to control activation of dehumidification

Duct Mounted Relative Humidity Sensor (BAYSENS037*)

Field installed, duct mounted humidity sensor that measures temperature and relative humidity. Relative humidity input is used to control activation of dehumidification.

Integrated Comfort System (BAYSENS073*)

This sensor features remote zone sensing and timed override with override cancellation. It is used with a Trane Integrated Comfort™ building management system.

Integrated Comfort System (BAYSENS074*)

This sensor features single setpoint capability and timed override with override cancellation. It is used with a Trane Integrated Comfort™ building management system.

Remote Zone Sensor (BAYSENS016*)

This bullet type temperature sensor can be used for outside air (ambient) sensing, return air temperature sensing, supply air temperature sensing, remote temperature sensing (uncovered). Wiring procedures vary according to the particular application and equipment involved. Refer to the unit's wiring diagrams for proper connections.

Remote Zone Sensor (BAYSENS077*)

This sensor can be used with BAYSENS106*, 108*, 110*, 800* Remote Panels. When this sensor is wired to a BAYSENS800* Remote Panel, wiring must be 18 AWG Shielded Twisted Pair (Belden 8760 or equivalent). Refer to the specific Remote Panel for wiring details.

Thermostat

The unit must have a thermostat to operate.

- BAYSTAT151
One Heat/One Cool Auto changeover digital display thermostat.
- BAYSTAT155
Three Heat/Two Cool Auto changeover display thermostat.
- BAYSENS150
Three Heat/Two Cool Auto changeover digital display thermostat. Seven day programmable thermostat with night setback.

High Temperature Sensor (FIAHTST001*)

This sensor connects to the Symbio™ 700 Emergency Stop Input and provides high limit “shutdown” of the unit. The sensor is used to detect high temperatures due to a high thermal event in the air conditioning or ventilation ducts. The sensor is designed to mount directly to the sheet metal duct. Each kit contains two sensors. The return air duct sensor (X13100040010) is set to open at 135°F. The supply air duct sensor (X13100040020) is set to open at 240°F. The control can be reset after the temperature has been lowered approximately 25°F below the cutout setpoint.

Digital Display Zone Sensor (BAYSENS135*)

LCD display provides heat, cool, auto, on, and off status. Display includes two temperature setpoints, and a lockable setting with °F or °C indicators.

Touch Screen Programmable Zone Sensor (BAYSENS800)

This sensor uses a BACnet® MS/TP link to communicate zone temperature and setpoints. Sensor includes Auto, Heat, Cool, or Off system switch, as well as Fan Auto or On switch. This is a seven day programmable thermostat with night setback.

Notes:

- *Not compatible with VAV units. Requires BACnet® communications.*
- *For additional sensors, refer to the product catalog.*

Note: *BAYSSENS800* with BACnet® enabled on the Symbio™ controller will report fault detection and diagnostics at the zone sensor. This functionality is only applicable if the customer does not have a building management system, and the unit is running standalone with the BAYSENS800.*

Evaporator Frost Control

Frostat is standard on all units.

Discharge Line Temp Switch (DLTS)

The DLTS is looped in series with HPC and LPC. It prevents the compressor from overheating (over 300°F dome temp) in case of indoor fan failure (cooling) or outdoor fan failure (heating).

Smoke Detector Sensor (Optional)

This sensor provides high limit “shutdown” of the unit and requires a manual reset. The sensor is used to detect smoke in the air conditioning or ventilation ducts.

Notes:

- *The supply air smoke detector samples supply air. The return smoke detectors sample return air. The smoke detectors are designed to shut off the unit if smoke is sensed. This function is performed by sampling the airflow entering the unit at the return air opening. Follow the instructions provided below to assure that the airflow through the unit is sufficient for adequate sampling. Failure to follow these instructions will prevent the smoke detectors from performing its design function.*
- *Airflow through the unit is affected by the amount of dirt and debris accumulated on the indoor coil and filters. To insure that airflow through the unit is adequate for proper sampling by the return air smoke detector, complete adherence to the maintenance procedures, including recommended intervals between filter changes, and coil cleaning is required.*
- *Periodic checks and maintenance procedures must be performed on the smoke detector to insure that it will function properly. For detailed instructions concerning these checks and procedures, refer to the appropriate section(s) of the smoke detector Installation and Maintenance Instructions provided with the literature package for this unit.*
- *In order for the supply air smoke detector or return air smoke detector to properly sense smoke in the supply air stream or return air stream, the air velocity entering the smoke detector unit must be between 500 and 4000 feet per minute. Equipment covered in this manual will develop an airflow velocity that falls within these limits over the entire airflow range specified in the evaporator fan performance tables.*

Phase Monitor

This sensor monitors voltage between the 3 conductors of the 3 phase power supply. Two LED lights are provided:

- The green light indicates that a balanced 3 phase supply circuit is properly connected.
- The red light indicates that unit operation has been prevented. There are two conditions that will prevent unit operation:
 - The power supply circuit is not balanced with the proper phase sequence of L1, L2, L3 for the 3 conductors of a 3 phase circuit.
 - The line to line voltage is not between 180 volts and 633 volts.

Pre-Installation

⚠ WARNING

Fiberglass Wool!

Exposure to glass wool fibers without all necessary PPE equipment could result in cancer, respiratory, skin or eye irritation, which could result in death or serious injury. Disturbing the insulation in this product during installation, maintenance or repair will expose you to airborne particles of glass wool fibers and ceramic fibers known to the state of California to cause cancer through inhalation.

You **MUST** wear all necessary Personal Protective Equipment (PPE) including gloves, eye protection, a NIOSH approved dust/mist respirator, long sleeves and pants when working with products containing fiberglass wool.

Precautionary Measures:

- Avoid breathing fiberglass dust.
- Use a NIOSH approved dust/mist respirator.
- Avoid contact with the skin or eyes. Wear long-sleeved, loose-fitting clothing, gloves, and eye protection.
- Wash clothes separately from other clothing; rinse washer thoroughly.
- Operations such as sawing, blowing, tear-out, and spraying may generate fiber concentrations requiring additional respiratory protection. Use the appropriate NIOSH approved respirator.

First Aid Measures:

- **Eye Contact** - Flush eyes with water to remove dust. If symptoms persist, seek medical attention.
- **Skin Contact** - Wash affected areas gently with soap and warm water after handling.

Precautionary Measures

- Avoid breathing fiberglass dust.

- Use a NIOSH approved dust/mist respirator.
- Avoid contact with the skin or eyes. Wear long-sleeved, loose-fitting clothing, gloves, and eye protection.
- Wash clothes separately from other clothing: rinse washer thoroughly.
- Operations such as sawing, blowing, tear-out, and spraying may generate fiber concentrations requiring additional respiratory protection. Use the appropriate NIOSH approved respiration in these situations.

First Aid Measures

Eye Contact - Flush eyes with water to remove dust. If symptoms persist, seek medical attention.

Skin Contact - Wash affected areas gently with soap and warm water after handling.

⚠ WARNING

Hazardous Voltage!

Failure to disconnect power before servicing could result in death or serious injury.

Disconnect all electric power, including remote disconnects before servicing. Follow proper lockout/tagout procedures to ensure the power can not be inadvertently energized. Verify that no power is present with a voltmeter.

1. Remove power to the unit and gain access to the electric heat elements by removing the horizontal supply cover.
2. Visually inspect the heater elements for the following:
 - a. Elements that are no longer secured to the white ceramic insulator.
 - b. Elements touching each other or touching metal.
 - c. Severely kinked, drooping, or broken elements.
3. If an element has detached from its ceramic insulator, carefully put it back into place.
4. Replace the heater elements if they present symptoms noted in the above Step 2.a and 2.c.

Dimensions and Weights

Dimensional Data

Figure 2. 6 to 10 tons standard efficiency

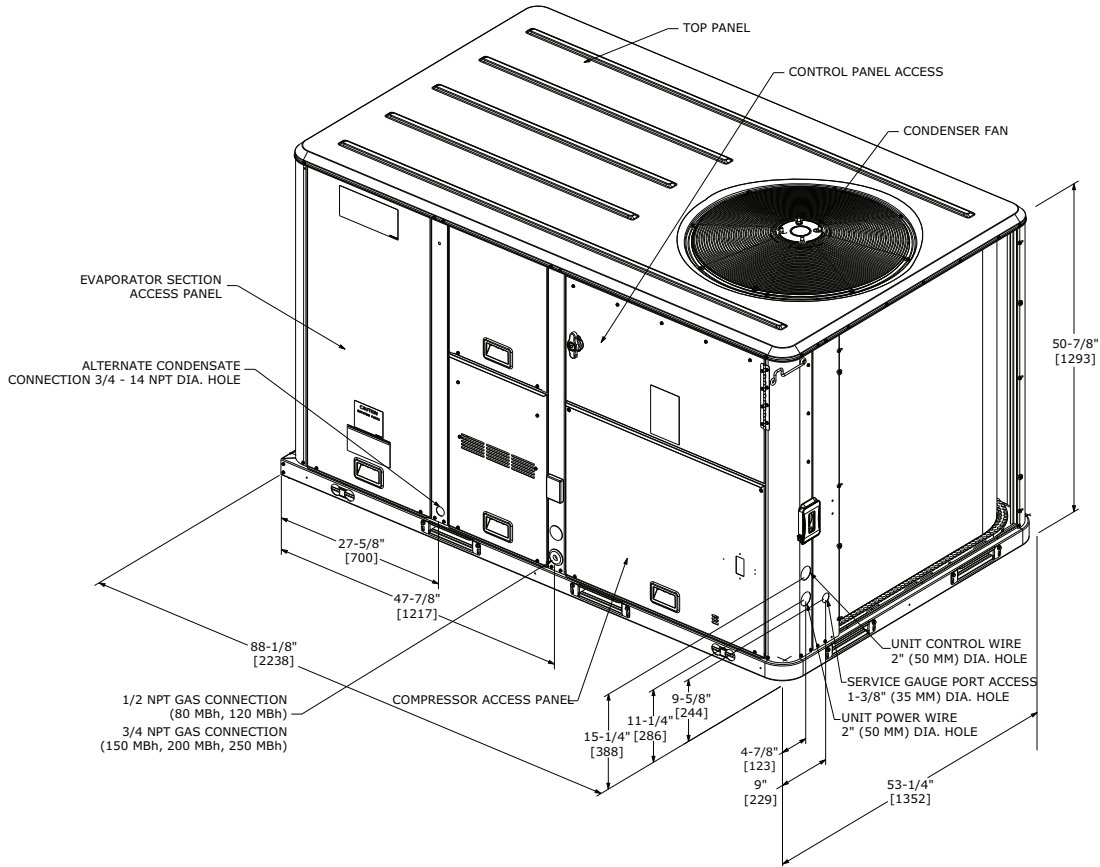
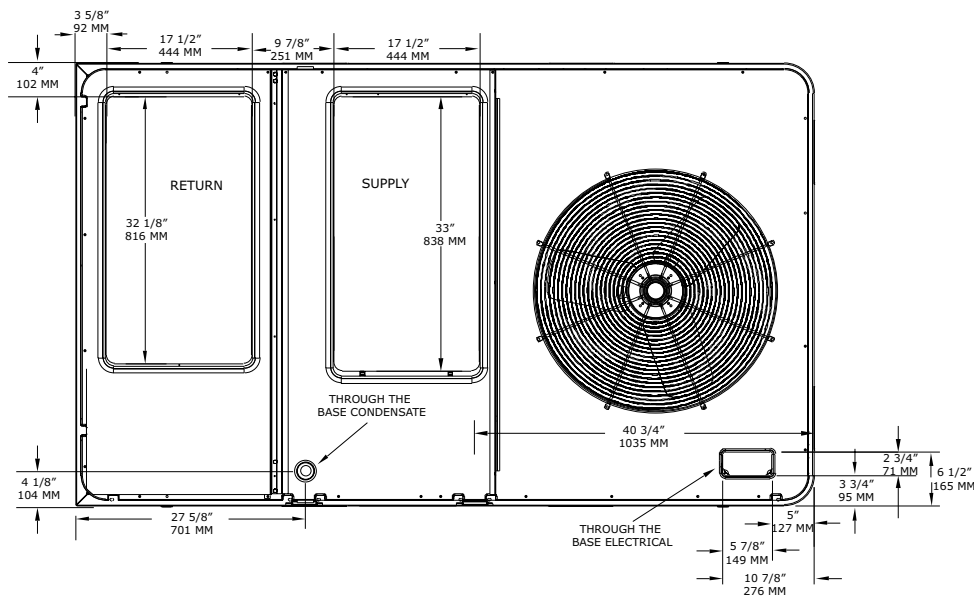

Figure 3. 6 to 10 tons standard efficiency – downflow airflow supply/return, through-the-base utilities



Dimensions and Weights

Figure 4. 6 to 10 tons standard efficiency – horizontal airflow supply/return

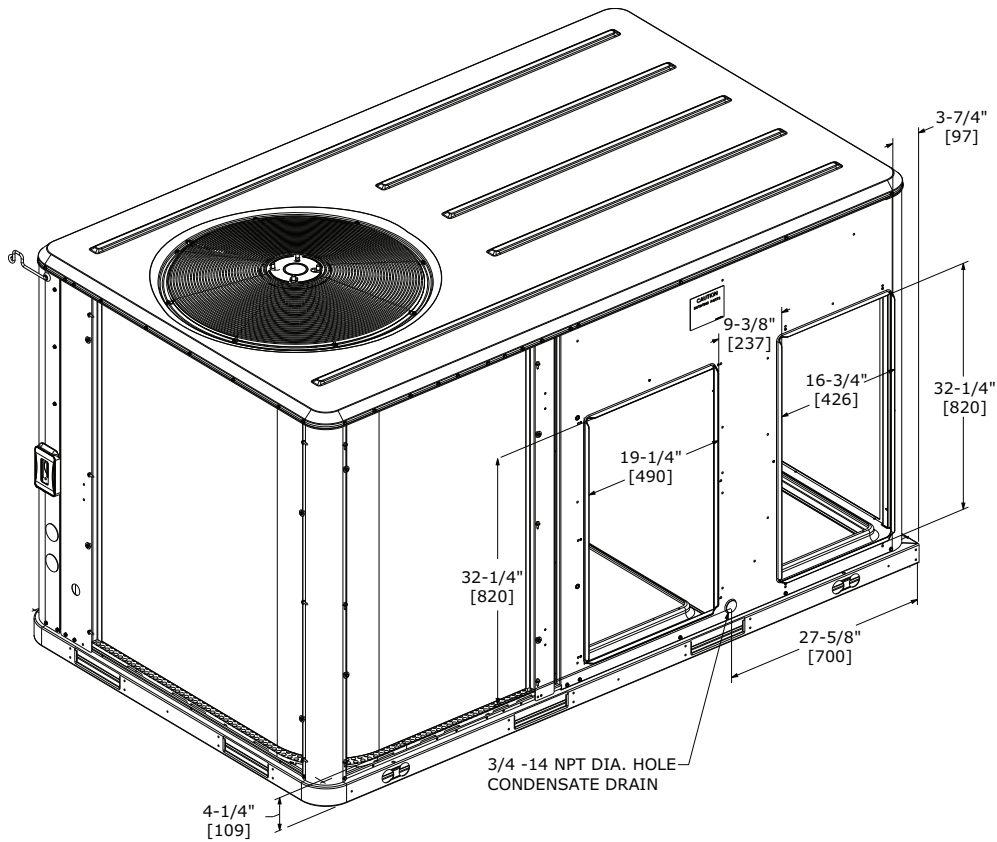

Figure 5. 6 to 10 tons standard efficiency — unit clearance and roof opening

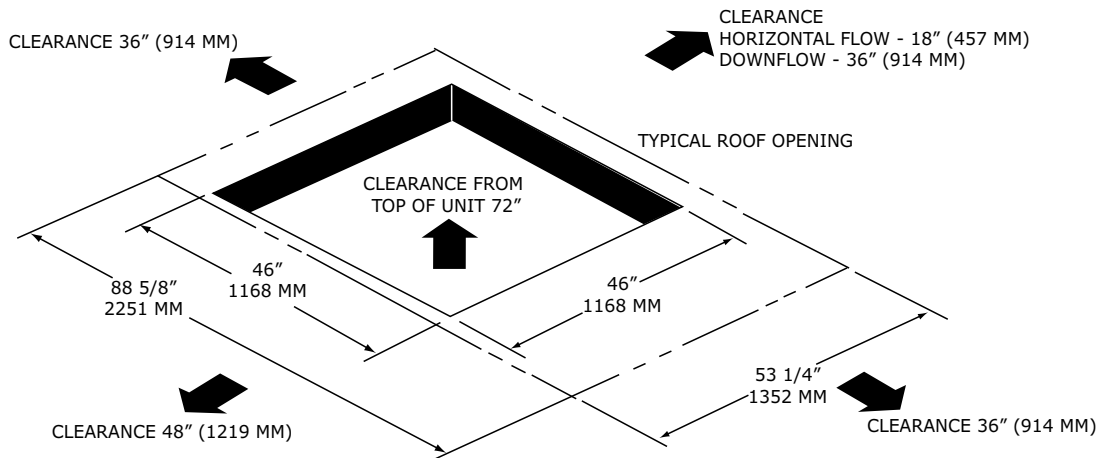

Figure 6. 6 to 10 tons standard efficiency – roof curb

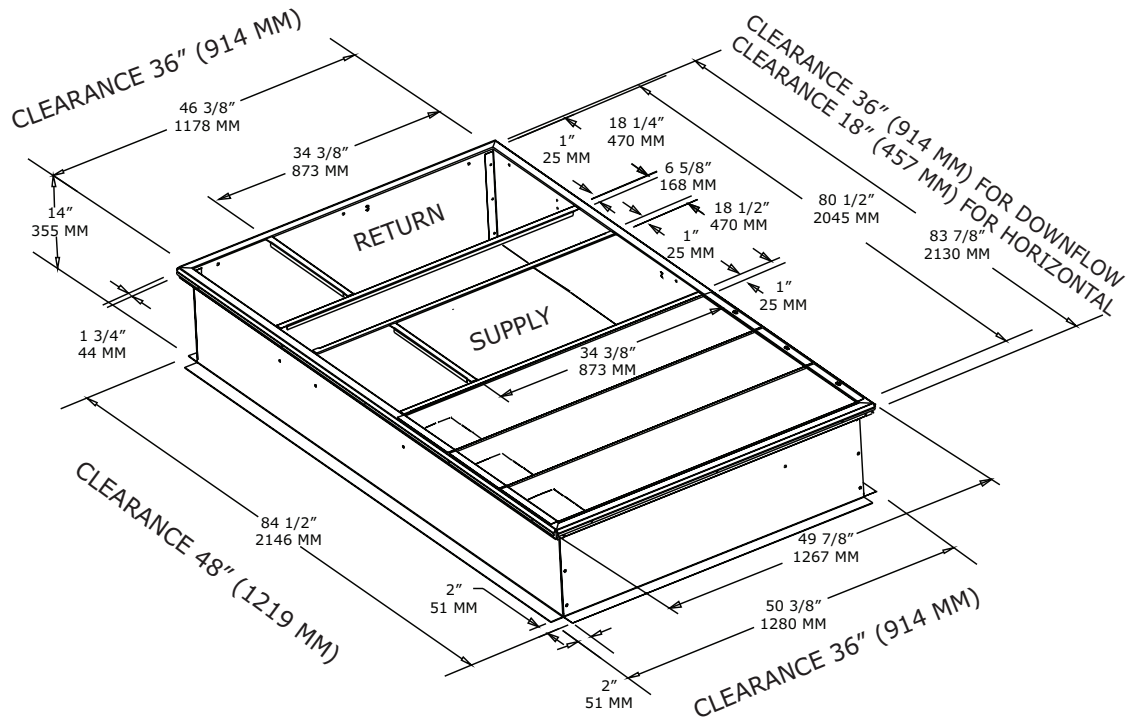
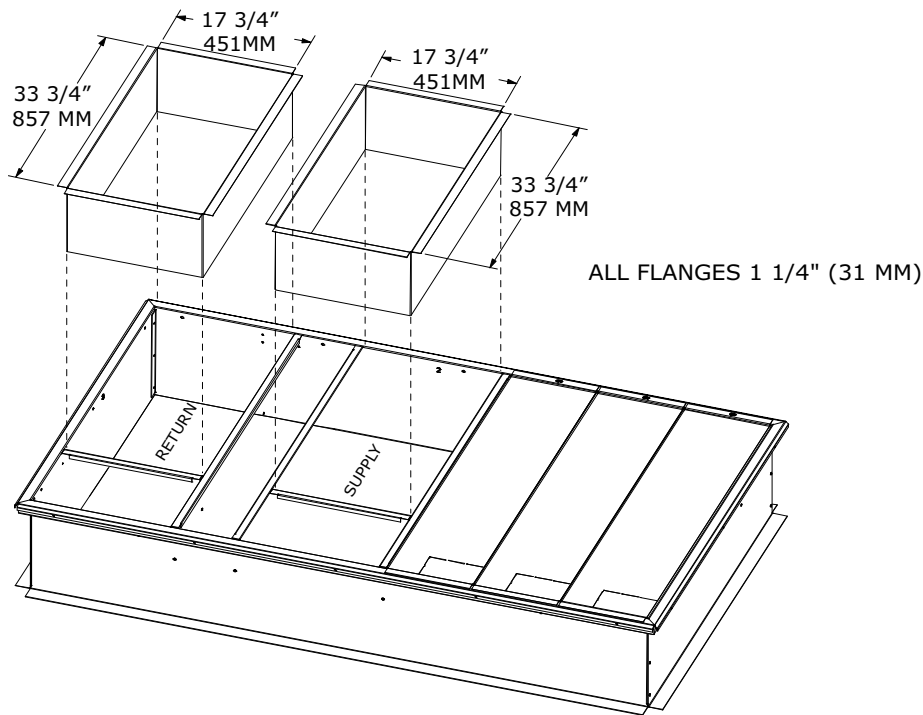

Figure 7. 6 to 10 tons standard efficiency – downflow duct connections, field fabricated



Dimensions and Weights

Figure 8. 6 to 10 tons standard efficiency – swing diameter for hinged door(s) option

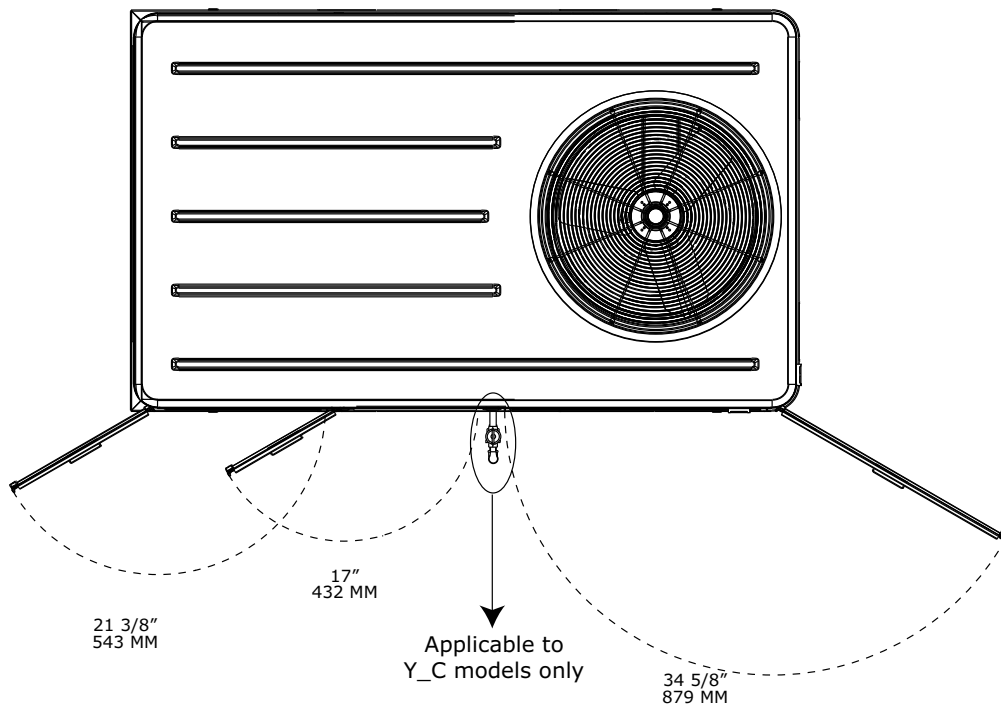

Figure 9. 12.5 tons standard efficiency

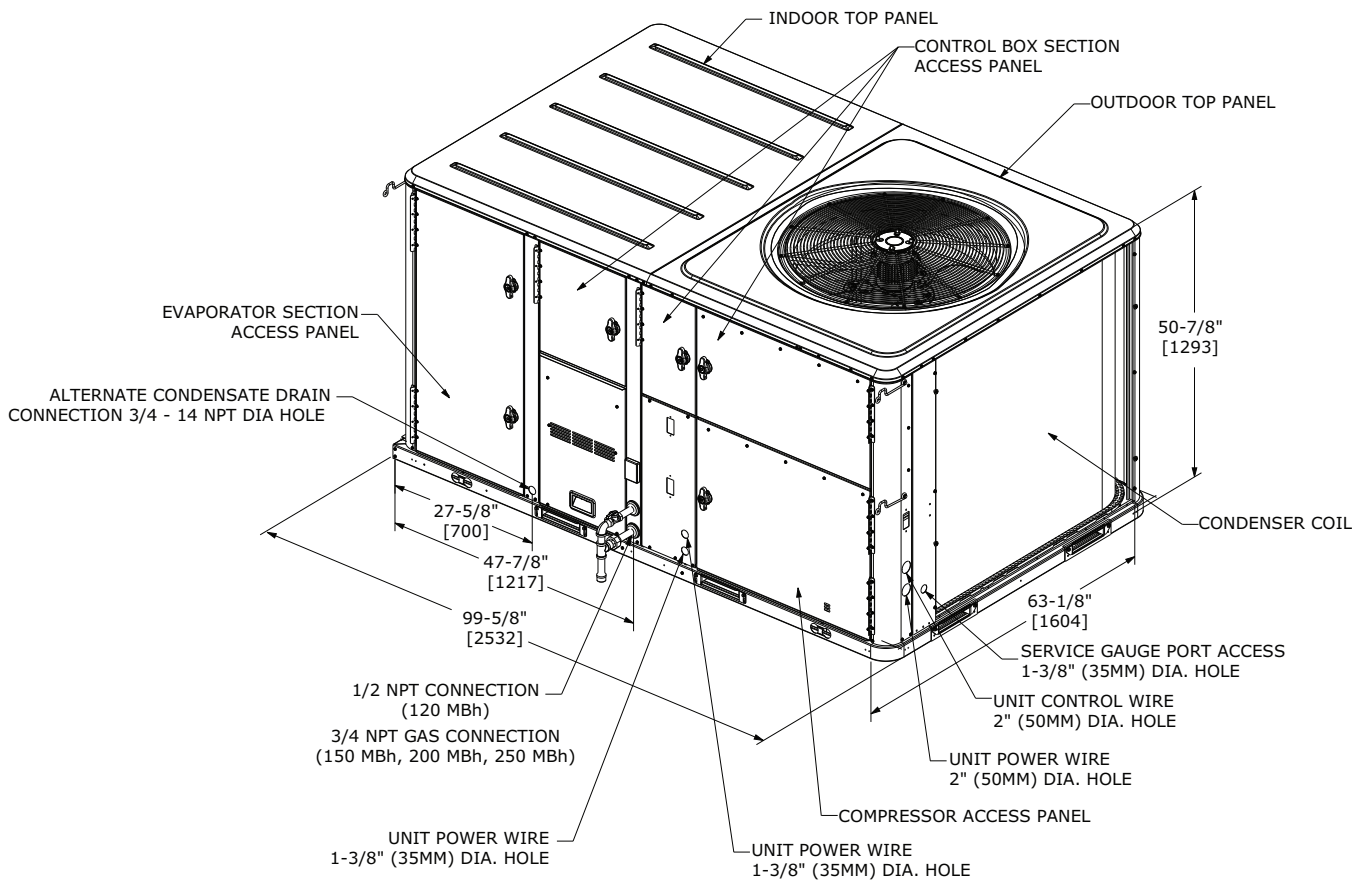

Figure 10. 12.5 tons standard efficiency – downflow airflow supply/return, through-the-base utilities

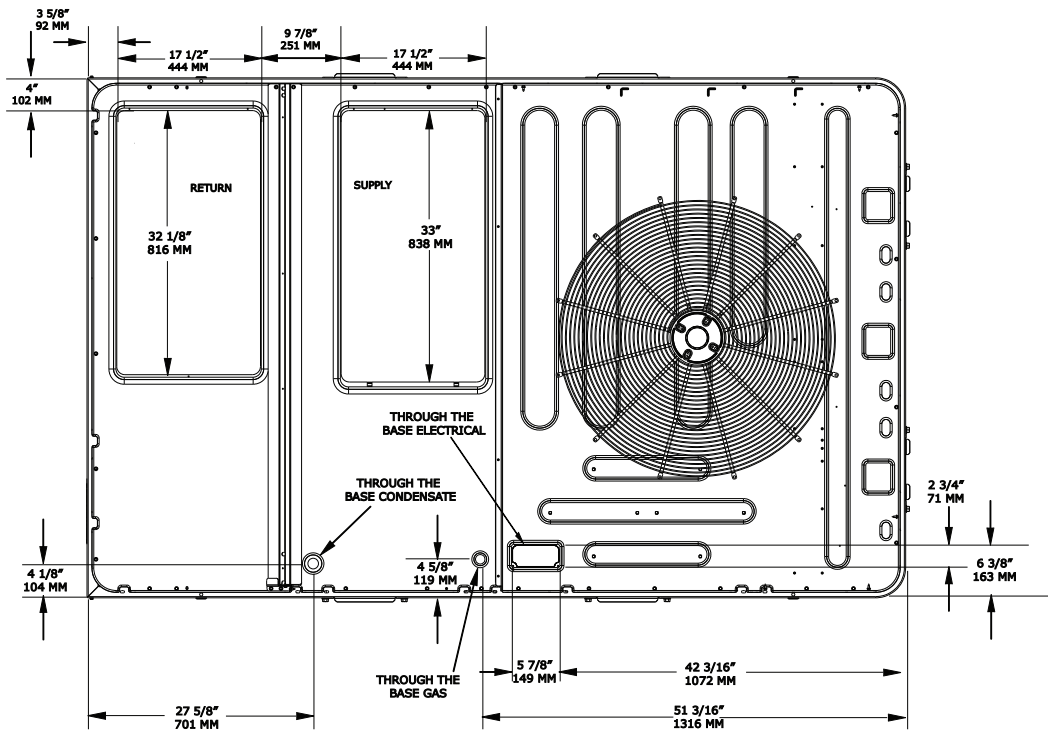
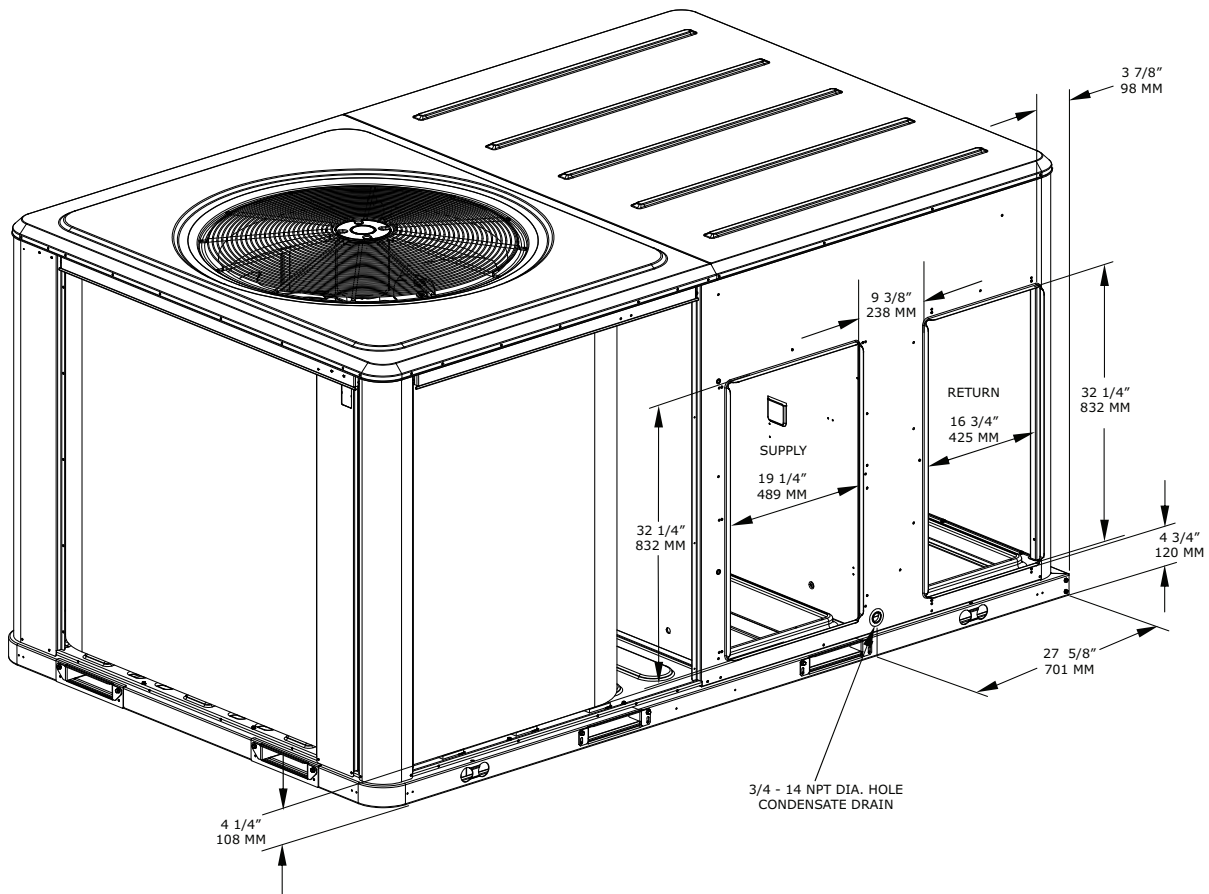

Figure 11. 12.5 tons standard efficiency – horizontal airflow, supply and return



Dimensions and Weights

Figure 12. 12.5 tons standard efficiency – unit clearance and roof opening

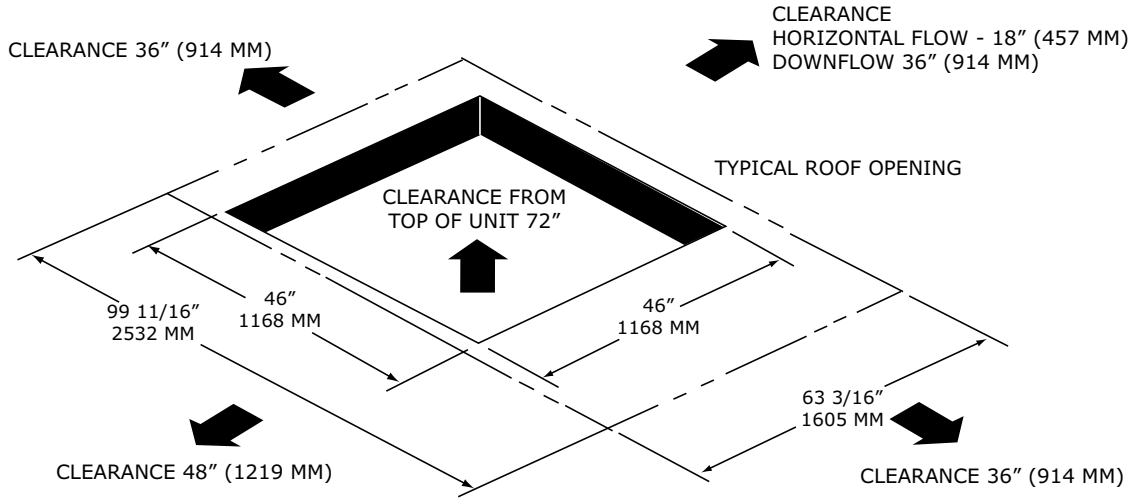

Figure 13. 12.5 tons standard efficiency – roof curb

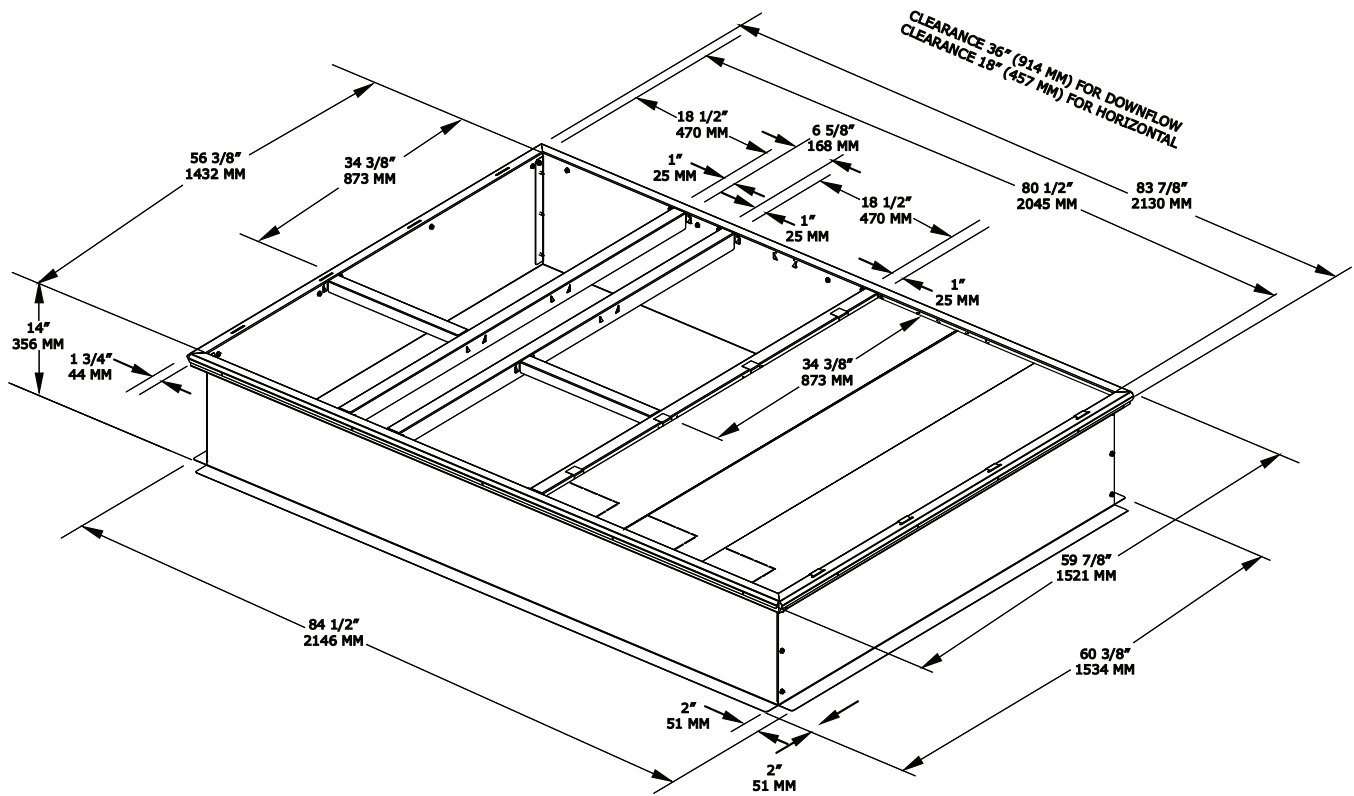

Figure 14. 12.5 tons standard efficiency – swing diameter for hinged door(s) option

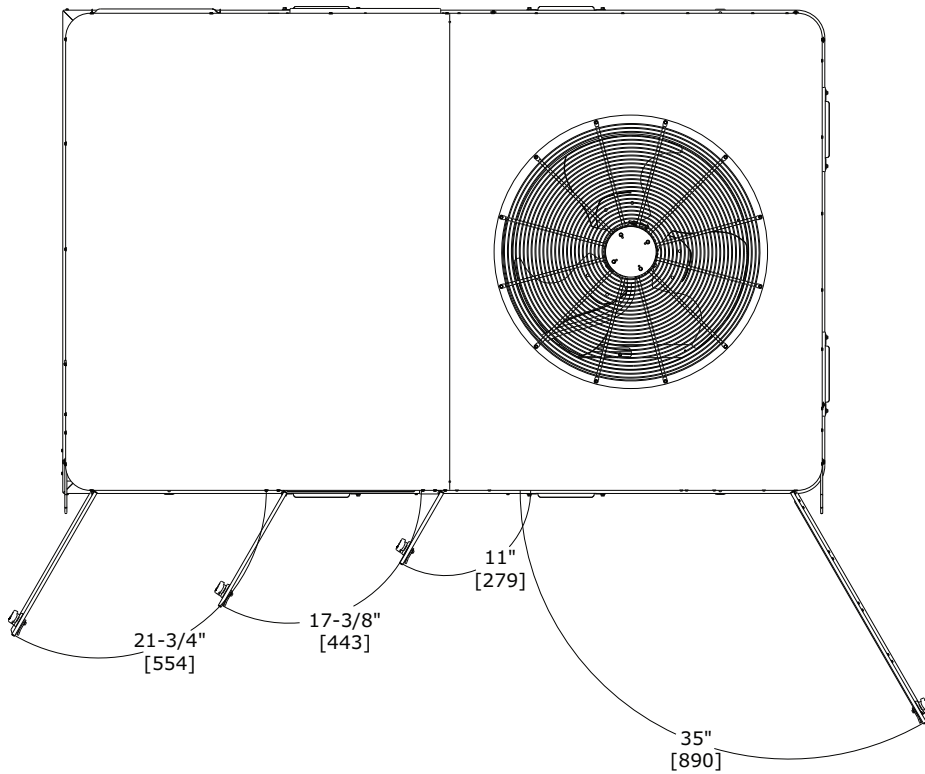
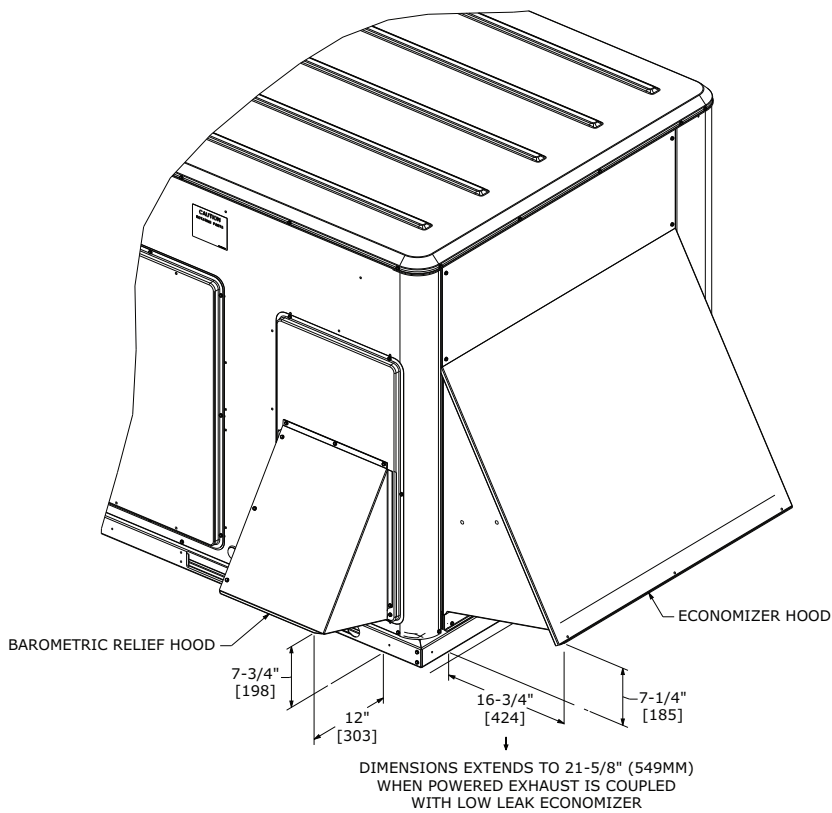

Figure 15. 6 to 12.5 tons standard efficiency – economizer, manual or motorized fresh air damper



Dimensions and Weights

Figure 16. 6 to 12.5 tons standard efficiency – power exhaust

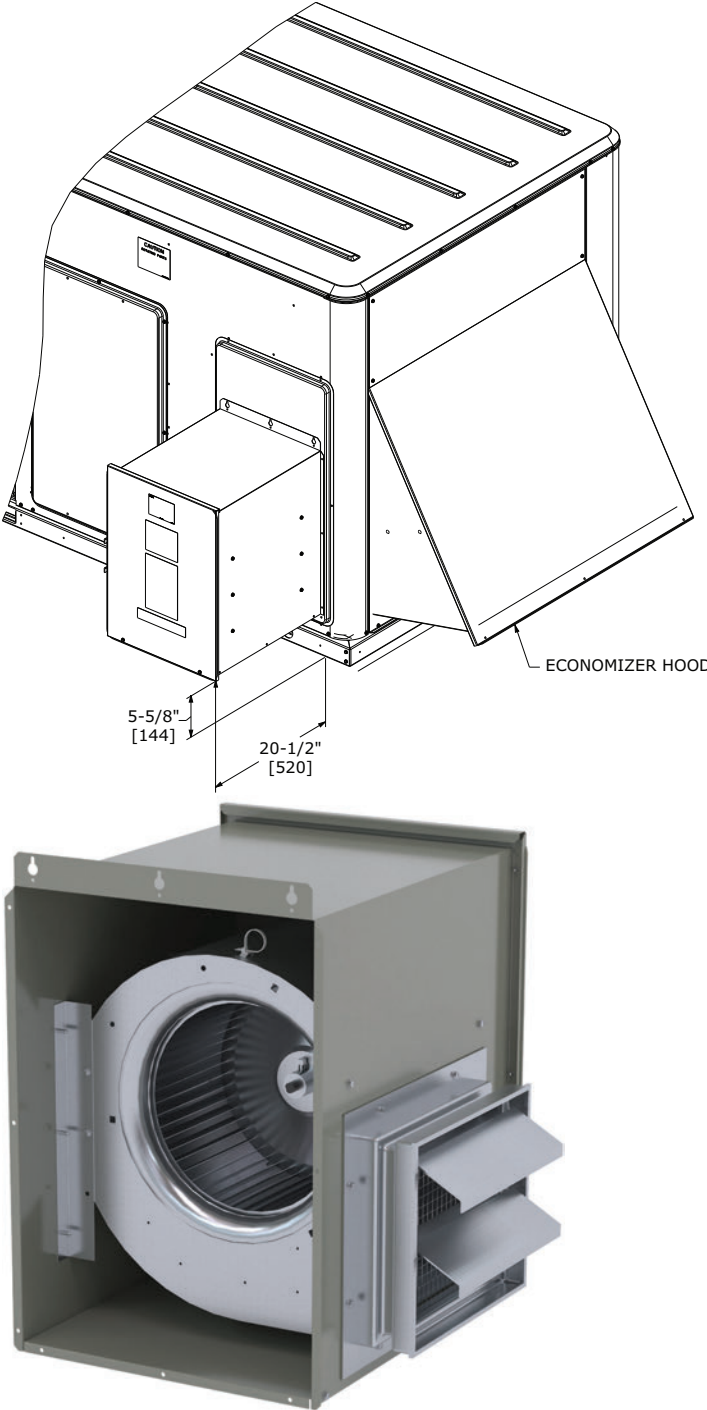

Figure 17. 15 to 25 tons standard efficiency – power exhaust

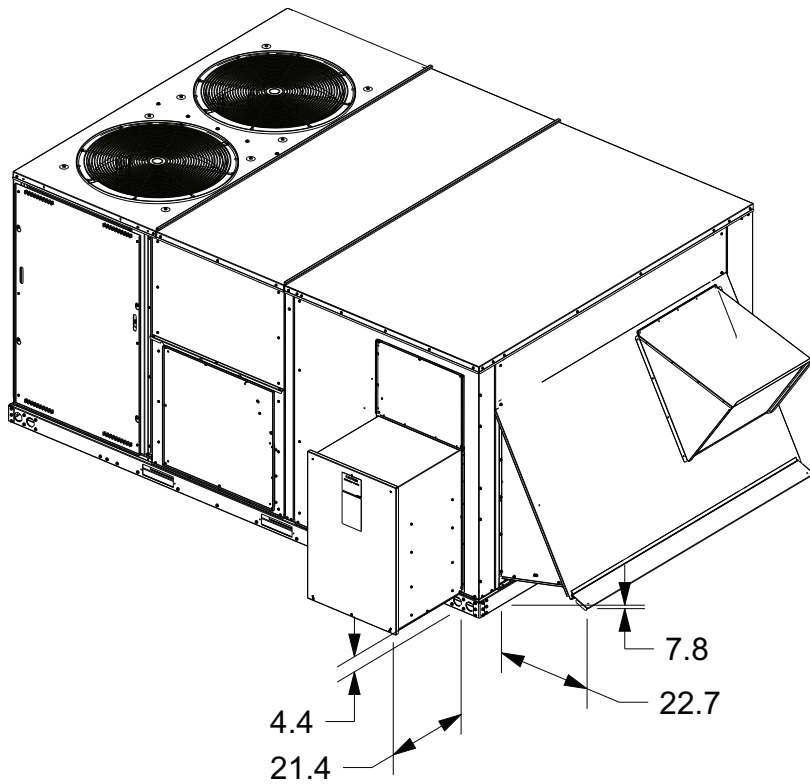
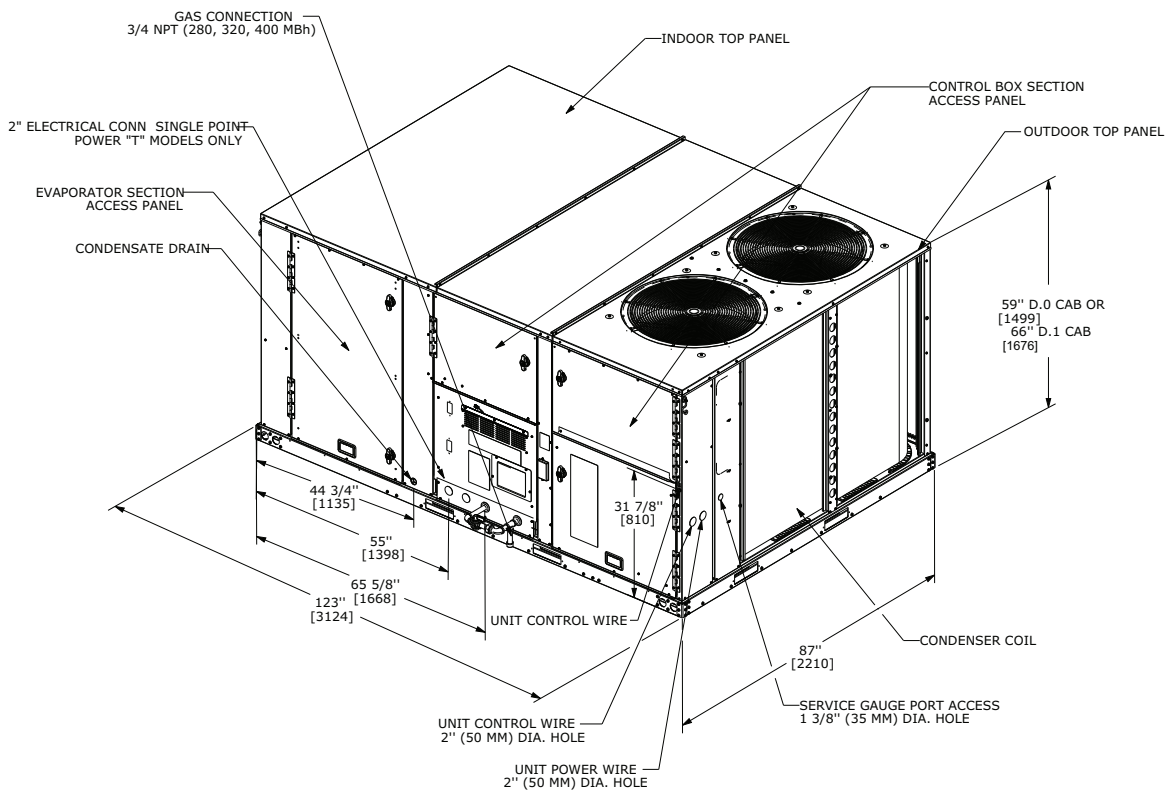

Figure 18. 15 to 25 tons standard efficiency



Note: Cabinet size for 15 to 15 ton units: D0.

Dimensions and Weights

Figure 19. 15 to 25 tons standard efficiency – downflow airflow supply/return, through-the-base utilities

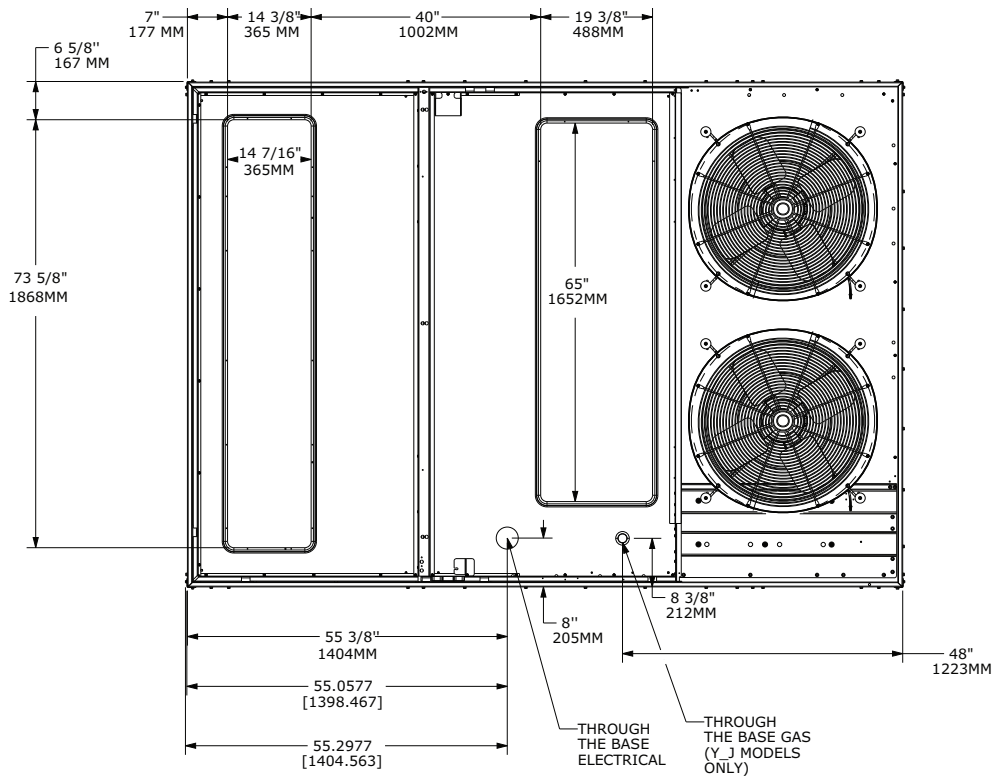

Figure 20. 15 to 25 ton standard efficiency – horizontal airflow supply/return

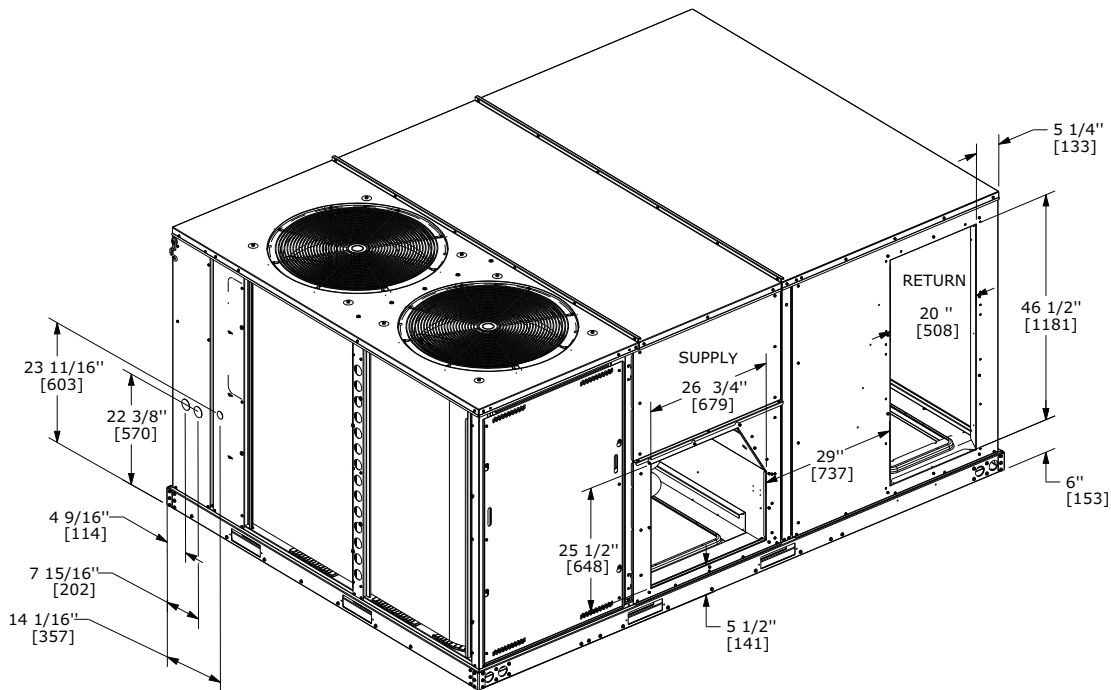

Figure 21. 15 to 25 tons standard efficiency – unit clearance and roof opening

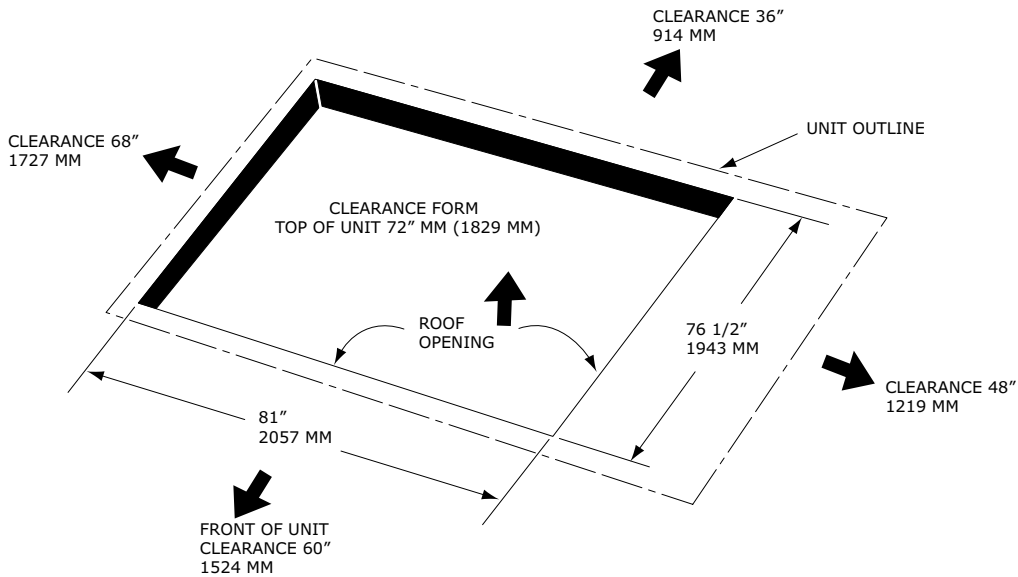
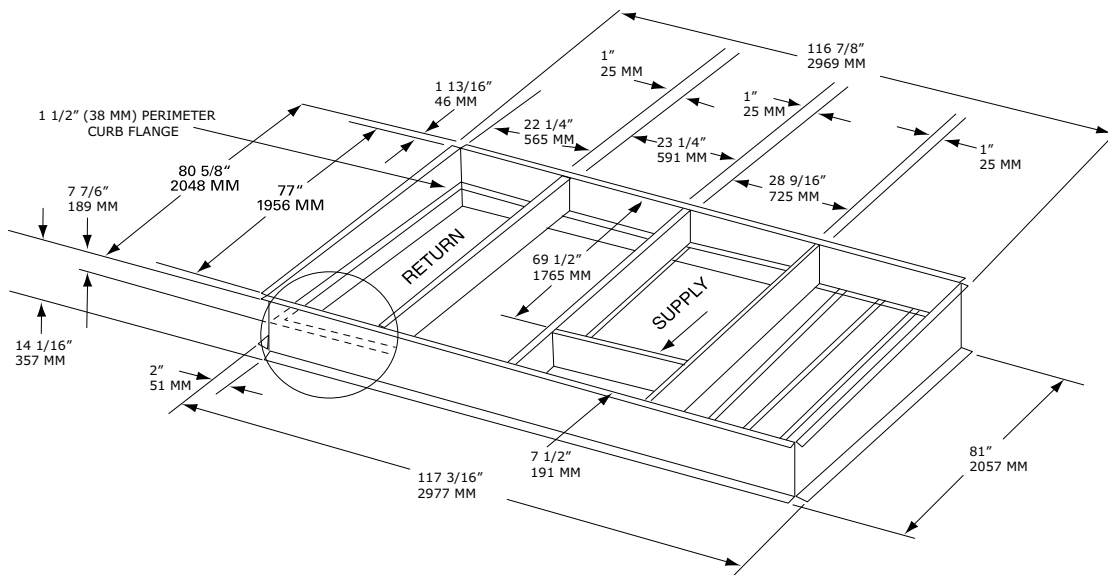
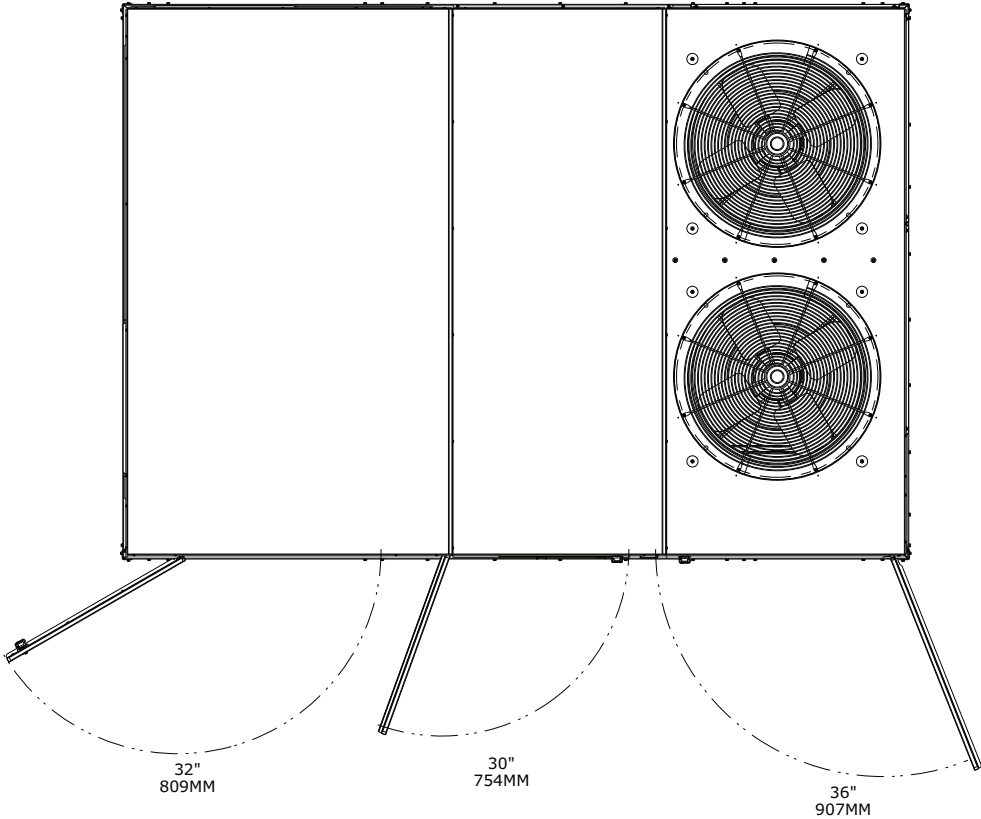

Figure 22. 15 to 25 tons standard efficiency – roof curb



Dimensions and Weights

Figure 23. 15 to 25 ton standard efficiency – swing diameter for hinged door(s) option



Clearances

Figure 24, p. 25 illustrates the minimum operating and service clearances for either a single or multiple unit installation. These clearances are the minimum distances necessary to assure adequate serviceability, cataloged unit

capacity, and peak operating efficiency. Providing less than the recommended clearances may result in condenser coil starvation, “short-circuiting” of exhaust and economizer airflows, or recirculation of hot condenser air.

Figure 24. Typical installation clearances for single and multiple unit applications

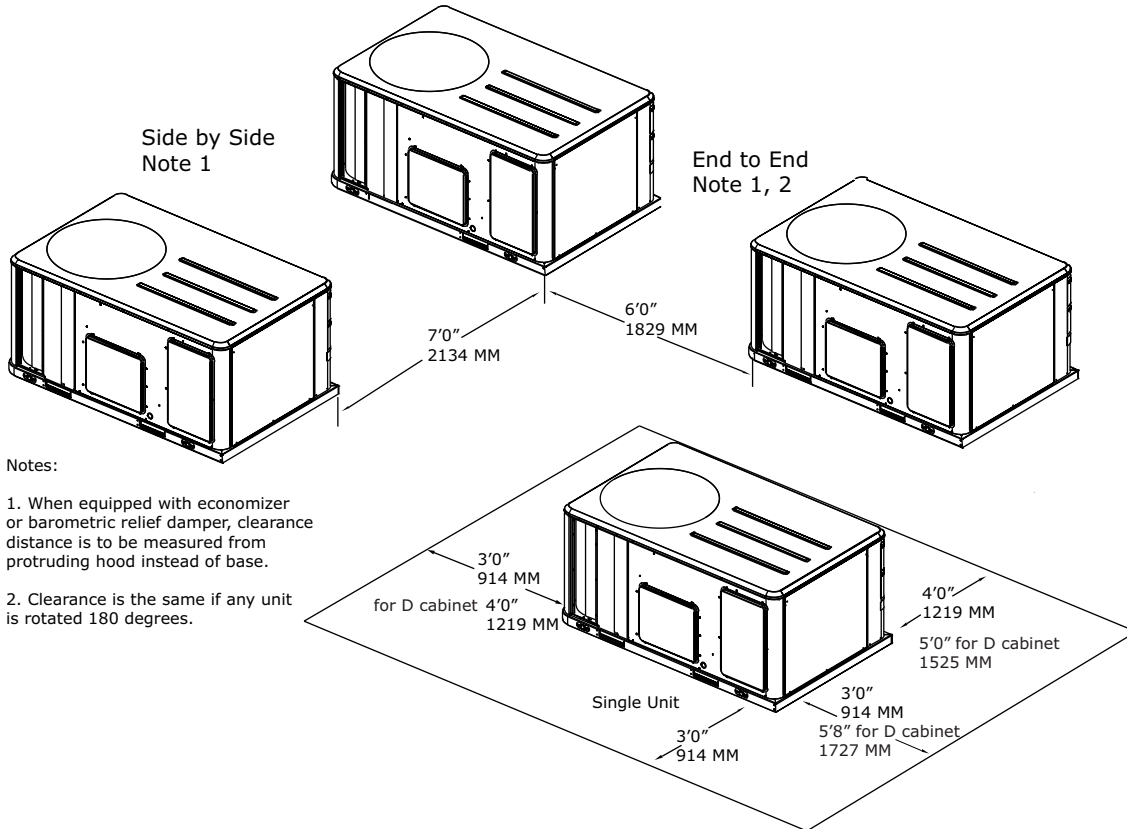

Weights

Table 1. Model weights, corner weights (lbs), and center of gravity dimensions (in.)

Tons	Unit Model No.	Model Weights ^(a)		Corner Weights ^(b)				Center of Gravity (in.)	
		Shipping	Net	A	B	C	D	Length	Width
6	TSJ072	1007	909	298	278	160	172	43	19
7.5	TSJ090	1011	913	300	280	161	172	43	19
8	TSJ102	1027	929	305	285	164	176	43	19
10	TSJ120	1037	939	308	288	165	177	43	19
12.5	TSJ150	1412	1218	356	360	252	250	50	26
15	TSJ180	2040	1820	611	447	322	440	52	36
17.5	TSJ210	2070	1850	612	463	334	441	53	36
20	TSJ240	2140	1920	689	472	309	451	50	34
25	TSJ300	2190	1970	684	484	332	469	51	35

^(a) Weights are approximate. Weights do not include additional factory or field installed options/accessories. For option/accessory additional weights to be added to unit weight, reference the following table.

^(b) Corner weights are given for information only.

Dimensions and Weights

Figure 25. Corner weights

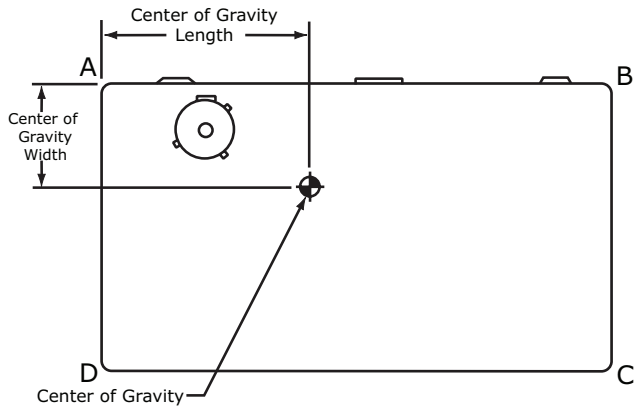

Table 2. Factory installed options (FIOPS)/accessory net weights (lb)

Accessory	TSJ072-120	TSJ150	TSJ180-300
	6, 7.5, 8.5, 10 Tons	12.5 Tons	15, 17.5, 20, 25 Tons
Barometric Relief	10	10	40
Economizer	36	36	91
Electric Heaters	44	50	75
Hinged Doors	12	12	20
Low Leak Economizer - Downflow	91	91	150
Low Leak Economizer - Horizontal	—	—	180
Manual Outside Air Damper	26	26	15
Motorized Outside Air Damper	30	30	82
Oversized Motor	14	—	30
Powered Convenience Outlet	38	50	50
Powered Exhaust	80	80	110
Reheat Coil	16	20	33
Roof Curb	105	111	235
Smoke Detector, Supply	5	5	5
Smoke Detector, Return	7	7	5
Through-the-Base Electrical	13	13	10
Unit Mounted Circuit Breaker	5	5	10
Unit Mounted Disconnect	5	5	10

Notes:

1. Weights for options not listed are <5 lbs.
2. Net weight should be added to unit weight when ordering factory-installed accessories.
3. Weights are approximate.

Lifting and Rigging

⚠ WARNING

Heavy Object!

Failure to follow instructions below could result in unit dropping which could result in death or serious injury, and equipment or property-only damage. Ensure that all the lifting equipment used is properly rated for the weight of the unit being lifted. Each of the cables (chains or slings), hooks, and shackles used to lift the unit must be capable of supporting the entire weight of the unit. Lifting cables (chains or slings) may not be of the same length. Adjust as necessary for even unit lift.

⚠ WARNING

Improper Unit Lift!

Failure to properly lift unit in a LEVEL position could result in unit dropping and possibly crushing operator/technician which could result in death or serious injury, and equipment or property-only damage. Test lift unit approximately 24 inches (61 cm) to verify proper center of gravity lift point. To avoid dropping of unit, reposition lifting point if unit is not level.

Figure 26. Rigging and center of gravity — 6 to 12.5 tons

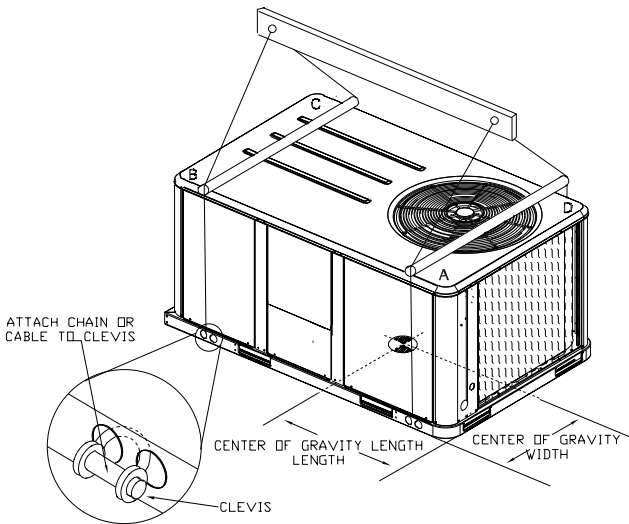
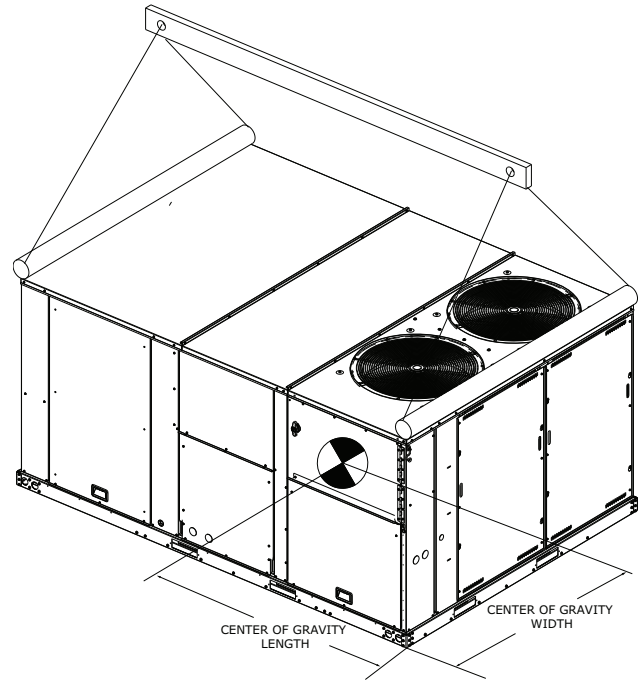

Figure 27. Rigging and center of gravity — 15 to 25 tons



Installation

⚠ WARNING

Heavy Object!

Failure to follow instructions below could result in unit dropping which could result in death or serious injury, and equipment or property-only damage. Ensure that all the lifting equipment used is properly rated for the weight of the unit being lifted. Each of the cables (chains or slings), hooks, and shackles used to lift the unit must be capable of supporting the entire weight of the unit. Lifting cables (chains or slings) may not be of the same length. Adjust as necessary for even unit lift.

NOTICE

Roof Damage!

System contains oil and refrigerant under high pressure. Roofs should be protected from exposure to oils and refrigerant in the system. If rooftop is not protected, damage to the roof may occur.

Important: Refer to local building codes for proper installation. All installation must comply with local building codes.

Horizontal Units

If the unit is installed at ground level, elevate it above the snow line. Provide concrete footings at each support location with a "full perimeter" support structure or a slab foundation for support. Refer to the weights information in the Dimensions and Weights chapter for the unit's operating and point loading weights when constructing a footing foundation.

If anchoring is required, anchor the unit to the slab using hold down bolts or isolators. Isolators should be installed to minimize the transmission of vibrations into the building.

⚠ WARNING

Risk of Roof Collapsing!

Failure to ensure proper structural roof support could cause the roof to collapse, which could result in death or serious injury and property damage.

Confirm with a structural engineer that the roof structure is strong enough to support the combined weight of the roofcurb, the unit, and any accessories.

For rooftop applications, ensure the roof is strong enough to support the combined unit and support structural weight. Refer to maximum unit and corner weights (center of gravity) dimensions in the Dimensions and Weights section for the unit operating weights. If anchoring is required, anchor the unit to the roof with hold-down bolts or isolators.

Check with a roofing contractor for proper waterproofing procedures.

Ductwork

Supply and return air openings as viewed from the rear of the unit are shown in the following drawings.

Figure 28. 6 to 10 tons standard efficiency – horizontal airflow supply/return

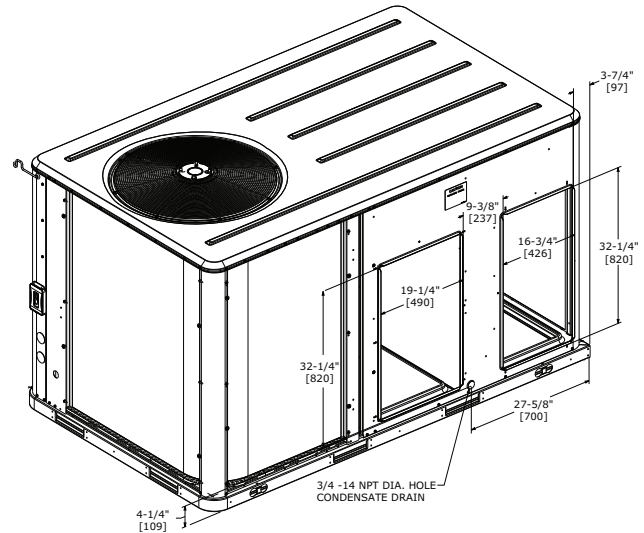

Figure 29. 12.5 tons standard efficiency – horizontal airflow, supply and return

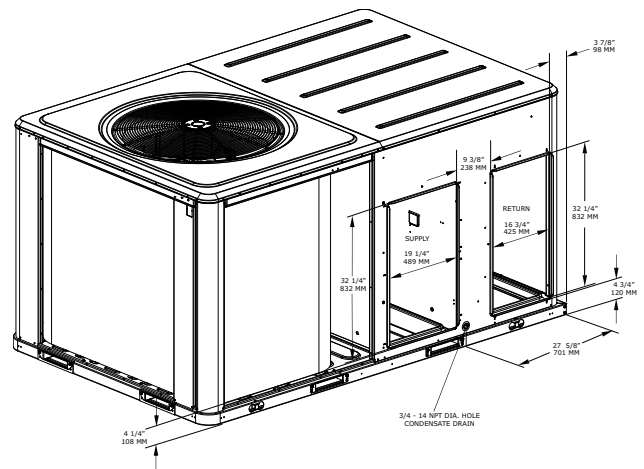
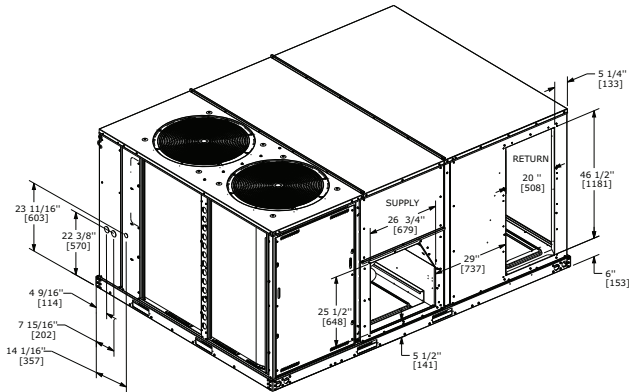

Figure 30. 15 to 25 ton standard efficiency – horizontal airflow supply/return



Supply and return air openings as viewed from a downflow configuration are shown in the following drawings.

Elbows with turning vanes or splitters are recommended to minimize air noise due to turbulence and to reduce static pressure.

When attaching the ductwork to the unit, provide a water tight flexible connector at the unit to prevent operating sounds from transmitting through the ductwork.

All outdoor ductwork between the unit and the structure should be weather proofed after installation is completed.

Figure 31. 6 to 10 tons standard efficiency – downflow airflow supply/return, through-the-base utilities

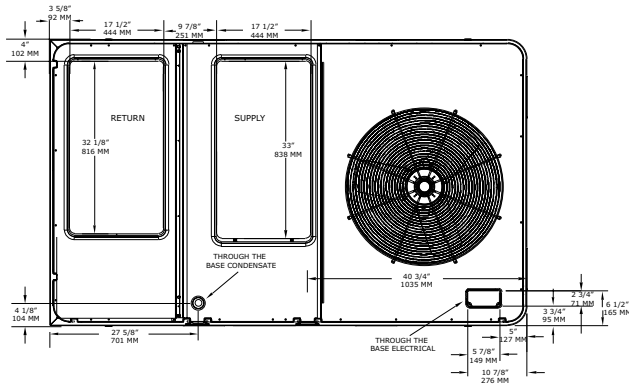

Figure 32. 12.5 tons standard efficiency – downflow airflow supply/return, through-the-base utilities

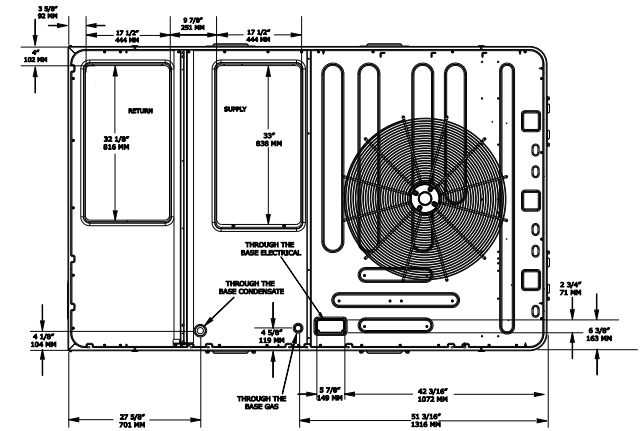

Figure 33. 15 to 25 tons standard efficiency – downflow airflow supply/return, through-the-base utilities

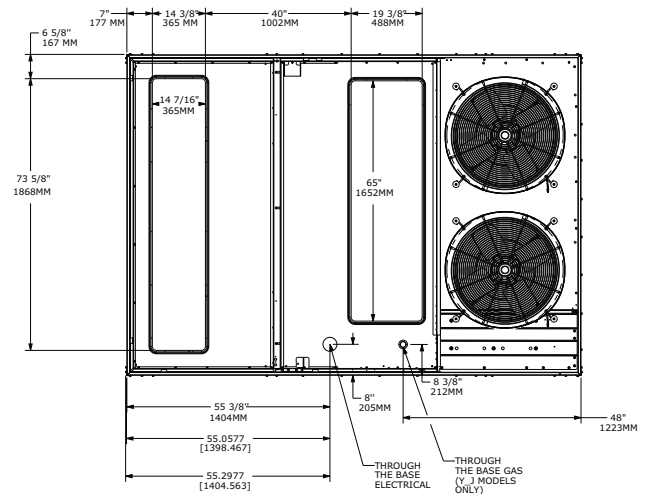

Table 3. Clearance required from duct to combustible surfaces

Model Number	Clearance required from duct to combustible surfaces (inches)
TSJ072	0
TSJ090	0
TSJ102	0
TSJ120	0
TSJ150	0
TSJ180	0
TSJ210	0
TSJ240	0
TSJ300	0

Roof Curb

Downflow

The roof curbs for these units consists of a “full perimeter” enclosure to support the unit just inside of the unit base rail. The 12.5 ton units contain a support base alignment rail and will extend past the end of the roof curb as shown in figures below

Before installing any roof curb, verify:

- It is the correct curb for the unit.
- The includes the necessary gaskets and hardware.
- The purposed installation location provides the required clearance for proper operation.
- Insure that the curb is level and square. The top surface of the curb must be true to assure an adequate curb-to unit seal.

⚠ WARNING

Combustible Materials!

Failure to maintain proper clearance between the unit and combustible materials could cause a fire which could result in death, serious injury, or property damage.

Refer to unit nameplate and installation instructions for proper clearances.

Verify that appropriate materials were used in the construction of roof and ductwork. Combustible materials should not be used in the construction of ductwork or roof curb that is in close proximity to heater elements or any hot surface. Any combustible material on the inside of the unit base should be removed and replaced with appropriate material.

Step-by-step curb assembly and installation instructions ship with each accessory roof curb kit. Follow the instructions carefully to assure proper fit-up when the unit is set into place.

Note: To assure proper condensate flow during operation, the unit (and curb) must be level.

If the unit is elevated, a field constructed catwalk around the unit is strongly recommended to provide easy access for unit maintenance and service.

Recommendations for installing the Supply Air and Return Air ductwork joining the roof curb are included in the curb instruction booklet. Curb ductwork must be fabricated and installed by the installing contractor before the unit is set into place.

Note: For sound consideration, cut only the holes in the roof deck for the ductwork penetrations. Do not cut out the entire roof deck within the curb perimeter.

Figure 34. View for base to roof curb alignment on C.0 cabinet on a 50" x 84" roof curb

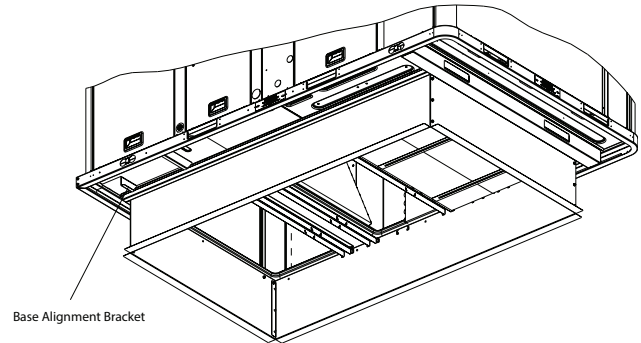
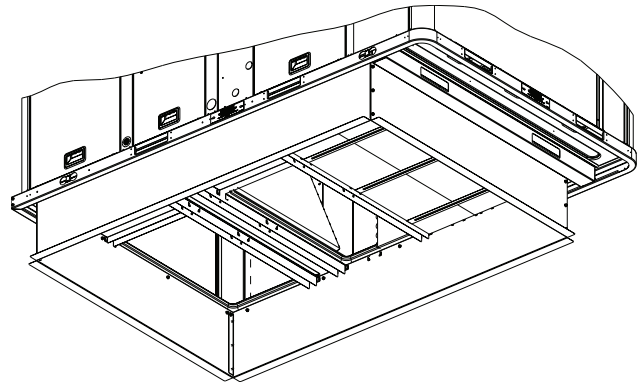

Figure 35. View for base to roof curb alignment on C.0 cabinet on a 60" x 84" roof curb



If a Curb Accessory Kit is not used:

- The ductwork can be attached directly to the factory-provided flanges around the unit's supply and return air openings. Be sure to use flexible duct connections at the unit.
- For “built-up” curbs supplied by others, gaskets must be installed around the curb perimeter flange and the supply and return air opening flanges.

Rigging

⚠ WARNING

Heavy Object!

Failure to follow instructions below could result in unit dropping which could result in death or serious injury, and equipment or property-only damage. Ensure that all the lifting equipment used is properly rated for the weight of the unit being lifted. Each of the cables (chains or slings), hooks, and shackles used to lift the unit must be capable of supporting the entire weight of the unit. Lifting cables (chains or slings) may not be of the same length. Adjust as necessary for even unit lift.

See Dimensions and Weights section for rigging illustration, and center-of-gravity dimensional data. Refer to the typical unit operating weights table before proceeding.

1. Confirm unit does not need additional moves by fork lift.
2. Prepare unit for rigging as follows:
 - 6 to 12.5 ton units: Remove all drill screws fastening wood protection to metal base rail. Remove all screws securing wooden protection to wooden top crate.
 - 15 to 25 ton units: Remove the front base rail bumper protection.

Note: For unit protection, the top crate should remain in place during lifting. If it must be removed prior to lifting, protect unit from damage. Top crate must be removed prior to operation.

⚠ WARNING

Improper Unit Lift!

Failure to properly lift unit in a LEVEL position could result in unit dropping and possibly crushing operator/technician which could result in death or serious injury, and equipment or property-only damage.

Test lift unit approximately 24 inches (61 cm) to verify proper center of gravity lift point. To avoid dropping of unit, reposition lifting point if unit is not level.

3. Rig the unit as shown in the weights section. Attach adequate strength lifting slings to all four lifting brackets in the unit base rail. Do not use cables, chains, or slings except as shown.
4. Install a lifting bar, as shown in the Dimensions and Weights chapter, to protect the unit and to facilitate a uniform lift. The minimum distance between the lifting hook and the top of the unit should be 7 feet.
5. Test-lift the unit to ensure it is properly rigged and balanced, make any necessary rigging adjustments.

Figure 36. Fork pockets — 6 to 10 ton standard efficiency units

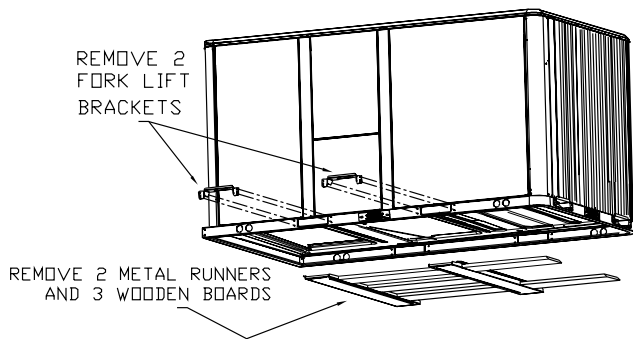

Figure 37. Fork pockets — 12.5 ton standard efficiency units

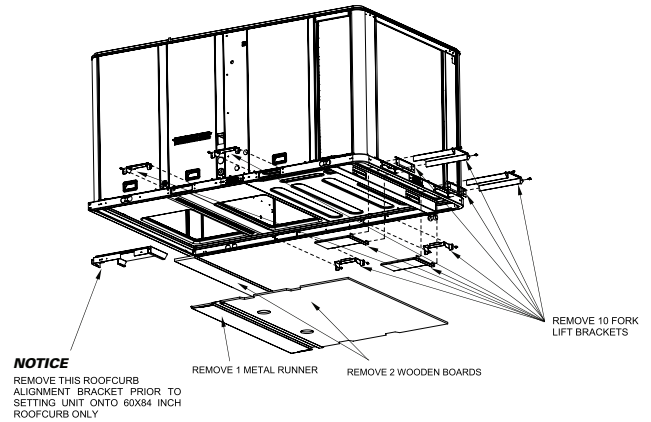
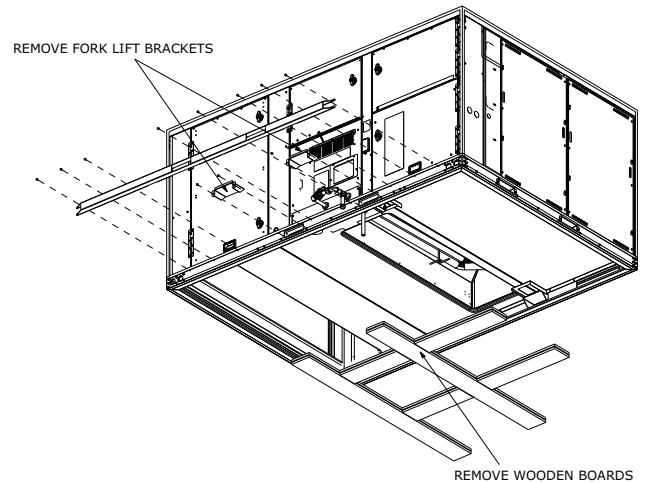

Figure 38. Fork pockets — 15 to 25 ton standard efficiency units



6. Lift the unit enough to allow the removal of base fork pocket protection components as shown in the following figures.
7. When C cabinet (digit 39 = C) units are installed on smaller existing roof curb (50"x 84") for replacement applications, do not remove alignment bracket. This bracket helps assure proper alignment of duct openings.
8. Downflow units; align the base rail of the unit with the curb rail while lowering the unit onto the curb. Make sure that the gasket on the curb is not damaged while positioning the unit.

General Unit Requirements

The checklist listed below is a summary of the steps required to successfully install a commercial unit. This checklist is intended to acquaint the installing personnel with what is required in the installation process. It does not replace the detailed instructions called out in the applicable sections of this manual.

Installation

- Check the unit for shipping damage and material shortage; file a freight claim and notify appropriate sales representative.
- Verify correct model, options and voltage from unit nameplate.
- Verify that the installation location of the unit will provide the required clearance for proper operation.
- Assemble and install the roof curb (if applicable). Refer to the latest edition of the curb installers guide that ships with each curb kit.
- Fabricate and install ductwork; secure ductwork to curb.
- Install pitch pocket for power supply through building roof. (If applicable)
- Rigging the unit.
- Set the unit onto the curb; check for levelness.
- Ensure unit-to-curb seal is tight and without buckles or cracks.
- Install and connect a condensate drain line to the evaporator drain connection.

Factory Installed Economizer

- Ensure the economizer has been pulled out into the operating position. Refer to the economizer installers guide for proper position and setup.
- Install all access panels.

Horizontal Discharge Conversion (6 to 12.5 Ton Units)

Notes:

- 15 to 25 ton units require purchase of an accessory kit for conversion.
- 6 to 12.5 ton units move the supply cover to return opening and return cover to supply opening.

Supplies Needed by Installer for Conversion: 3 ounce tube of high temperature RTV sealant (500°F / 260°C, similar to Dow Corning 736).

Note: Failure to use recommended sealant could result in unit performance loss.

If a unit is to be converted to a horizontal discharge, the following conversion must be performed:

1. Remove RETURN and SUPPLY duct covers.
2. Place SUPPLY DUCT COVER over down-flow return opening. (insulation side down)
3. Using self-drilling screws, (or screws removed from duct cover), screw through dimples to attach DUCT COVER to base.

Figure 39. Supply duct cover

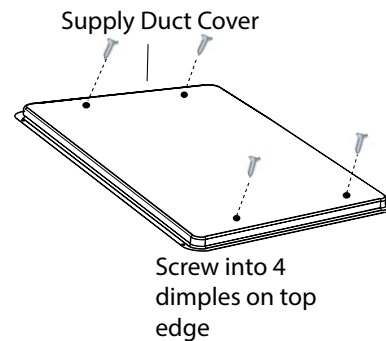

4. On original RETURN DUCT COVER, apply ¼" (6 mm.) continuous bead of 500°F RTV sealant around flange (opposite insulation side), as shown.

Figure 40. Return duct cover

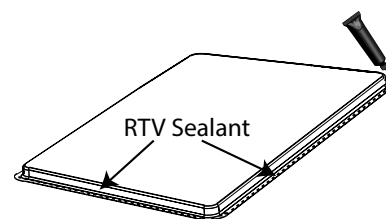

5. Slide RETURN DUCT COVER (insulation side up) into supply opening until inward edge of duct cover engages with the 2 retaining clips on the duct flange. Secure outward edge of the duct cover with two screws.

Notes:

- If unit is equipped with Return Air Smoke Detector, refer to field conversion instructions for horizontal discharge before installing return air duct.
- If unit is equipped with Discharge Air Sensing option refer to the following figure for proper tube positioning based on unit supply duct orientation / tonnage or refer to literature ACC-SVN240*-EN for more details.

Figure 41. Supply and return opening

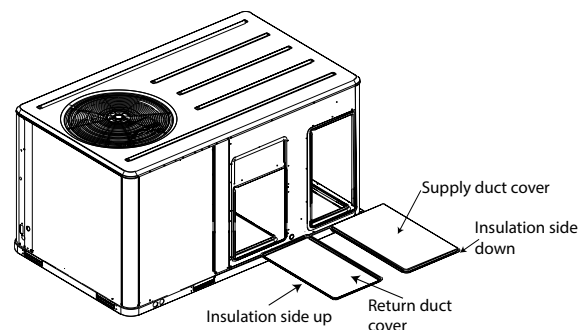

Return Air Smoke Detector

The factory installed Return Air Smoke Detector is installed in the downflow discharge position for 15 to 25 ton units. No additional field setup is required.

If a unit is to be converted to horizontal discharge, for 15 to 25 ton units, the following conversion must be performed:

1. If the unit has an economizer, it must be pulled out in the operating position.
2. Remove the 2 screws from the mounting brackets.

Note: Refer to downflow view for screw locations of 15 to 25 ton units.

Figure 42. Downflow bracket installation (view from horizontal return duct)

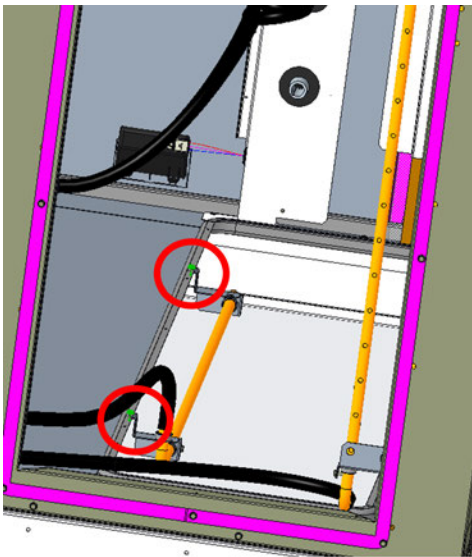

3. Lift the tube and bracket from the downflow duct opening. Rotate the tube and bracket assembly 90 degrees ensuring that the holes on the aluminium sensing tube face away from the unit and face the return air ductwork.

Note: Refer to horizontal views below of the 15 to 25 ton units.

Figure 43. Horizontal bracket installation (top view of unit)

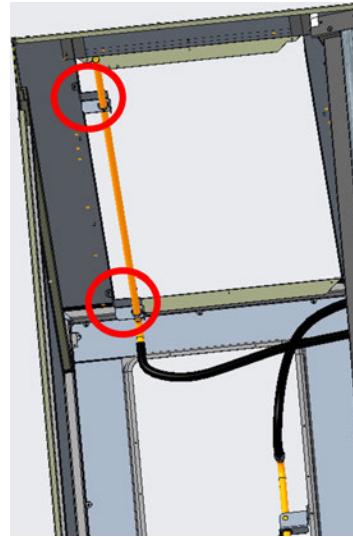

Note: Check to insure that the flexible tubing lies flat on the base pan surface.

4. Slide the top bracket down the aluminium sensing tube.
 - For 15 to 25 ton units with standard or low leak economizers, also secure the tube to the top right side of the horizontal opening flange (right side when viewed from outside unit facing horizontal supply). See Figure 44, p. 33.

Figure 44. Horizontal bracket installation (view from horizontal return duct)

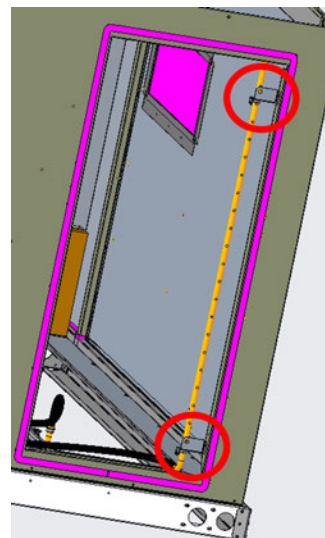

5. Using the remaining 2 screws and bracket removed in step 2, secure the bottom bracket.

Air-Fi® Wireless Communication Interface

The factory installed wireless communications interface is installed in the downflow discharge position.

If a unit is to be converted to horizontal discharge, the following conversion must be performed:

1. If the unit has an economizer, it must be pulled out in the operating position.
2. Remove the screw from the mounting bracket. Refer to downflow view for screw and bracket location.

Figure 45. Wireless communication interface - downflow

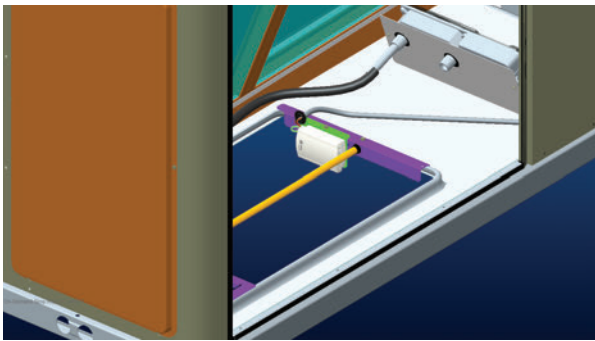

3. Mount the bracket in the horizontal discharge location. Refer to horizontal view for screw and bracket location.

Figure 46. Wireless communication interface - horizontal

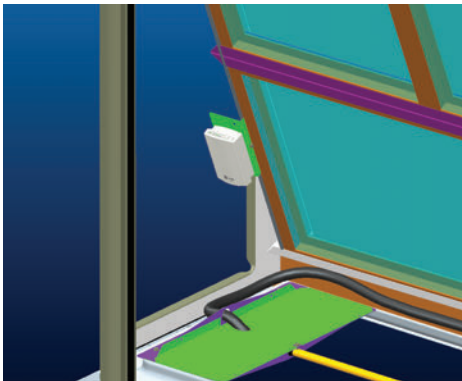

Note: Cable ties must be removed to allow the cable to extend to the horizontal mounting location.

Main Electrical Power Requirements

⚠ WARNING

Hazardous Voltage w/Capacitors!

Failure to disconnect power and discharge capacitors before servicing could result in death or serious injury.

Disconnect all electric power, including remote disconnects and discharge all motor start/run capacitors before servicing. Follow proper lockout/tagout procedures to ensure the power cannot be inadvertently energized. For variable frequency drives or other energy storing components provided by Trane or others, refer to the appropriate manufacturer's literature for allowable waiting periods for discharge of capacitors. Verify with a CAT III or IV voltmeter rated per NFPA 70E that all capacitors have discharged.

⚠ WARNING

Proper Field Wiring and Grounding Required!

Failure to follow code could result in death or serious injury.

All field wiring **MUST** be performed by qualified personnel. Improperly installed and grounded field wiring poses **FIRE** and **ELECTROCUTION** hazards. To avoid these hazards, you **MUST** follow requirements for field wiring installation and grounding as described in NEC and your local/state/national electrical codes.

- Verify that the power supply complies with the unit nameplate specifications.
- Inspect all control panel components; tighten any loose connections.
- Connect properly sized and protected power supply wiring to a field-supplied/installed disconnect switch and to the main power terminal block (HTB1) in the unit control panel.
- Install proper grounding wires to an earth ground.

Electric Heat Requirements

- Verify that the power supply complies with the electric heater specifications on the unit and heater nameplate.
- Inspect the heater junction box and control panel; tighten any loose connections.
- Check electric heat circuits for continuity.

Low Voltage Wiring

Mount the indoor thermostat, zone sensor, or programmable zone sensor in accordance with the corresponding thermostat installation instructions. Install

color-coded, weather-proof, multi-wire cable according to the field wiring instructions.

Note: Refer to thermostat or zone sensor wire installation guide for proper wire gauge.

Condensate Drain Configuration

⚠ WARNING

Hazardous Voltage!

Failure to disconnect power before servicing could result in death or serious injury.

Disconnect all electric power, including remote disconnects before servicing. Follow proper lockout/tagout procedures to ensure the power can not be inadvertently energized. Verify that no power is present with a voltmeter.

An evaporator condensate drain connection is provided on each unit. Refer to the ductwork section in the Installation chapter for the appropriate drain location.

The 6 to 12.5 tons condensate drain pan is convertible. Refer to the ductwork section in the Installation chapter for the drawings. It can be converted to drain condensate out the front side of the unit or through the base.

To convert drain condensate out the front of unit:

1. Remove evaporator access panel and supply air access panels.
2. Remove the support panel that the condensate drain pan exits through.
3. Slide the condensate drain pan out of the unit and rotate 180°.
4. Slide the condensate drain pan back into the unit, align the drain with the grommeted opening in the rear support panel and push until the coupling is seated in the grommet.
5. Replace the front support panel by aligning the panel with tabs in the raceway. Align the condensate drain pan support in the grommeted hole as the panel is put in place.
6. Replace evaporator access panel and supply air access panels.

To convert drain condensate through the base of unit:

1. Remove evaporator access panel and supply air access panels.
2. Remove the support panel that the condensate drain pan exits through.
3. Slide the condensate drain pan out of the unit.
4. Place on a level surface in the position it was removed from the unit.
5. Remove the plug knockout in the bottom of the drainpan to convert it to through the base drainage.
6. Plug the original condensate drain opening with a field supplied 3/4" NPT plug.

7. Slide the condensate drain pan back into the unit, align the drain support with the grommeted opening in the rear support panel and push until the support is seated in the grommet.
8. Replace the front support panel by aligning the panel with tabs in the raceway. Align the plugged condensate drain pan coupling in the grommeted hole as the panel is put in place.
9. Replace evaporator access panel and supply air access panels.

A condensate trap must be installed at the unit due to the drain connection being on the "negative pressure" side of the fan. Install the P-Trap using the guidelines in [Figure 47, p. 35](#).

A condensate drain line must be connected to the P-Trap. Pitch the drain lines at least 1/2 inch for every 10 feet of horizontal run to assure proper condensate flow. Do not allow the horizontal run to sag causing a possible double trap condition which could result in condensate backup due to "air lock".

Figure 47. Condensate trap installation

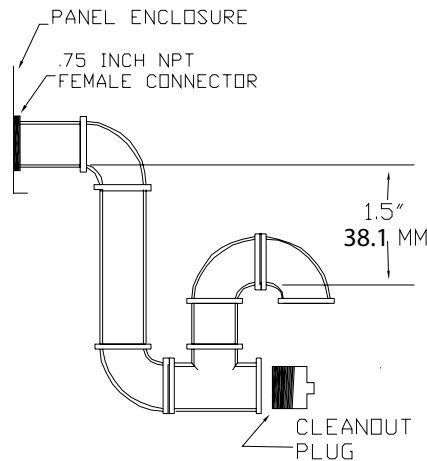

Note: Minimum if unit static is higher trap must be taller to drain appropriately.

Filter Installation

The quantity of filters is determined by unit size. Refer to General Data section in . Access to the filters is obtained by removing the filter access panel.

Note: Do not operate the unit without filters.

Field Installed Power Wiring

⚠ WARNING

Proper Field Wiring and Grounding Required!

Failure to follow code could result in death or serious injury.

All field wiring **MUST** be performed by qualified personnel. Improperly installed and grounded field wiring poses **FIRE** and **ELECTROCUTION** hazards. To avoid these hazards, you **MUST** follow requirements for field wiring installation and grounding as described in **NEC** and your local/state/national electrical codes.

An overall dimensional layout for the field installed wiring entrance into the unit is illustrated in the Dimensions and Weights chapter. To insure that the unit's supply power wiring is properly sized and installed, follow the following guidelines.

Verify that the power supply available is compatible with the unit's nameplate ratings. The available supply power must be within 10% of the rated voltage stamped on the nameplate. Use only copper conductors to connect the power supply to the unit.

NOTICE

Use Copper Conductors Only!

Failure to use copper conductors could result in equipment damage as the equipment was not designed or qualified to accept other types of conductors.

Important: *If the unit is not equipped with an optional factory installed non-fused disconnect switch or circuit breaker, a field supplied disconnect switch must be installed at or near the unit in accordance with the National Electrical Code (NEC latest edition).*

Main Unit Power

⚠ WARNING

Proper Field Wiring and Grounding Required!

Failure to follow code could result in death or serious injury.

All field wiring **MUST** be performed by qualified personnel. Improperly installed and grounded field wiring poses **FIRE** and **ELECTROCUTION** hazards. To avoid these hazards, you **MUST** follow requirements for field wiring installation and grounding as described in **NEC** and your local/state/national electrical codes.

⚠ WARNING

Hazardous Voltage!

Failure to disconnect power before servicing could result in death or serious injury.

Disconnect all electric power, including remote disconnects before servicing. Follow proper lockout/tagout procedures to ensure the power can not be inadvertently energized. Verify that no power is present with a voltmeter.

Standard Wiring

1. Location of the applicable electrical service entrance is illustrated in the Dimensions and Weights chapter. Complete the unit's power wiring connections at HTB1 main power terminal block in unit control panel. Refer to the customer connection diagram that is shipped with the unit for specific termination points.
2. Provide proper grounding for the unit in accordance with local and national codes.

Optional TBUE Wiring (Through-the-Base Electrical Option)

Location of the applicable electrical service is illustrated below. Refer to the customer connection diagram that is shipped with the unit for specific termination points. The termination points, depending on the customer option selected would be a factory mounted non-fused disconnect switch (UDC) or circuit breaker (UCB). If neither a factory mounted non-fused disconnect switch (UDC) or circuit breaker (UCB) was factory mounted, field wiring connections should be terminated in the control box at main panel power terminal block (HTB1).

Provide proper grounding for the unit in accordance with local and national codes.

Notes:

- *Black gasket is shipped from the factory and is located in the literature Ship With bag in the control box. Apply black gasket around conduit plate on all four sides after installation to prevent air leakage from the building entering the electrical enclosures.*
- *Seal any unused unit penetrations and around conduit and wiring at all unit and curb penetrations.*

Field-Installed Control Wiring

⚠ WARNING

Hazardous Voltage!

Failure to disconnect power before servicing could result in death or serious injury.

Disconnect all electric power, including remote disconnects before servicing. Follow proper lockout/tagout procedures to ensure the power can not be inadvertently energized. Verify that no power is present with a voltmeter.

⚠ WARNING

Proper Field Wiring and Grounding Required!

Failure to follow code could result in death or serious injury.

All field wiring **MUST** be performed by qualified personnel. Improperly installed and grounded field wiring poses **FIRE** and **ELECTROCUTION** hazards. To avoid these hazards, you **MUST** follow requirements for field wiring installation and grounding as described in **NEC** and your local/state/national electrical codes.

An overall layout of the various control options available with the required number of conductors for each control device is illustrated in the wiring diagram located on main control box door.

All field wiring must conform to NEC guidelines as well as state and local codes.

Control Power Transformer

The 24 volt control power transformers are to be used only with the accessories called out in this manual.

Transformers rated greater than 50 VA are equipped with internal circuit breakers. If a circuit breaker trips, turn "Off" all power to the unit before attempting to reset it.

⚠ WARNING

Hazardous Voltage!

Failure to disconnect power before servicing could result in death or serious injury.

Disconnect all electric power, including remote disconnects before servicing. Follow proper lockout/tagout procedures to ensure the power can not be inadvertently energized. Verify that no power is present with a voltmeter.

The transformers are located in the control panel. The circuit breaker is located on the right side of the transformer and can be reset by pressing in on the black reset button.

Controls using 24 Vac

Before installing any connecting wiring, refer to the Dimensions and Weights chapter for the electrical access locations provided on the unit and [Table 4, p. 39](#) for AC conductor sizing guidelines, and;

1. Use copper conductors unless otherwise specified.
2. Ensure that the AC control wiring between the controls and the unit's termination point does not exceed 2.5 ohms/conductor for the length of the run

NOTICE

Component Failure!

Resistance in excess of two and a half (2.5) ohms per conductor could result in component failure due to insufficient AC voltage supply.

Do not exceed two and a half (2.5) ohms per conductor for the length of the run.

Note: Be sure to check all loads and conductors for grounds, shorts, and mis-wiring.

3. Do not run the AC low voltage wiring in the same conduit with the high voltage power wiring.
4. Route low voltage wiring per illustrations below.

Figure 48. Low voltage wiring — B cabinet

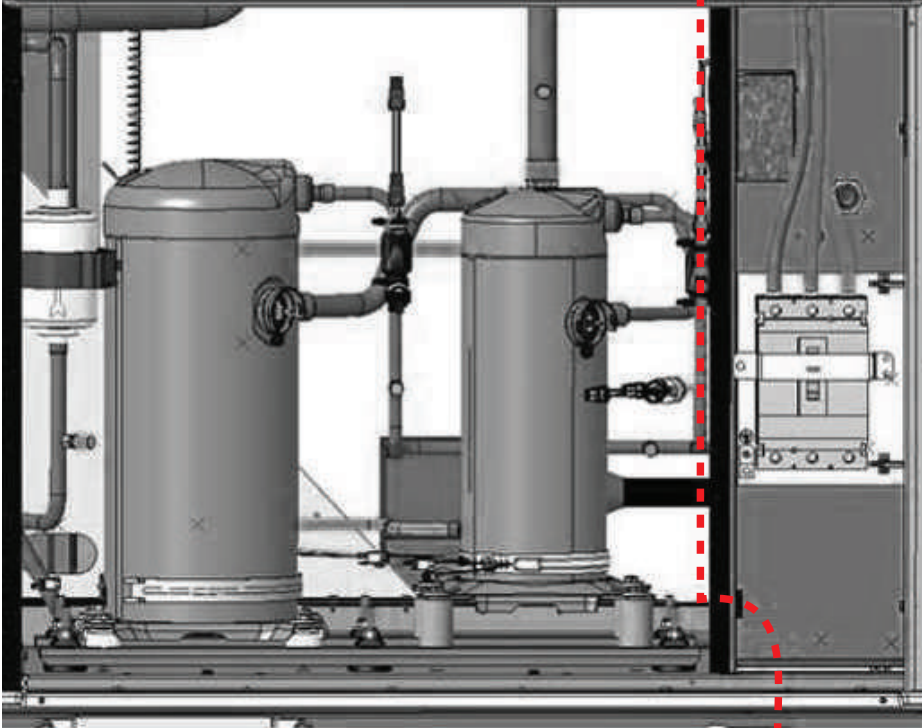

Figure 49. Low voltage wiring — C cabinet

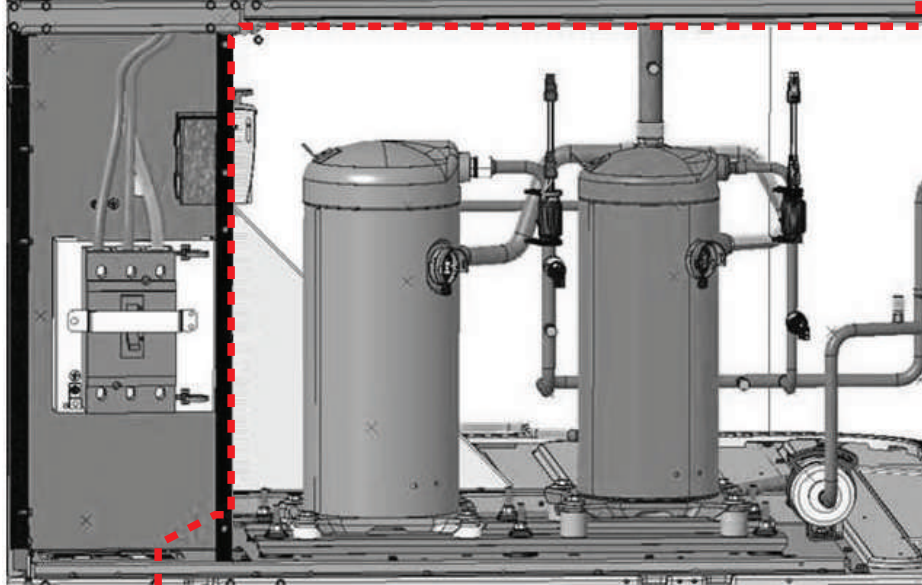

Figure 50. Low voltage wiring — D cabinet

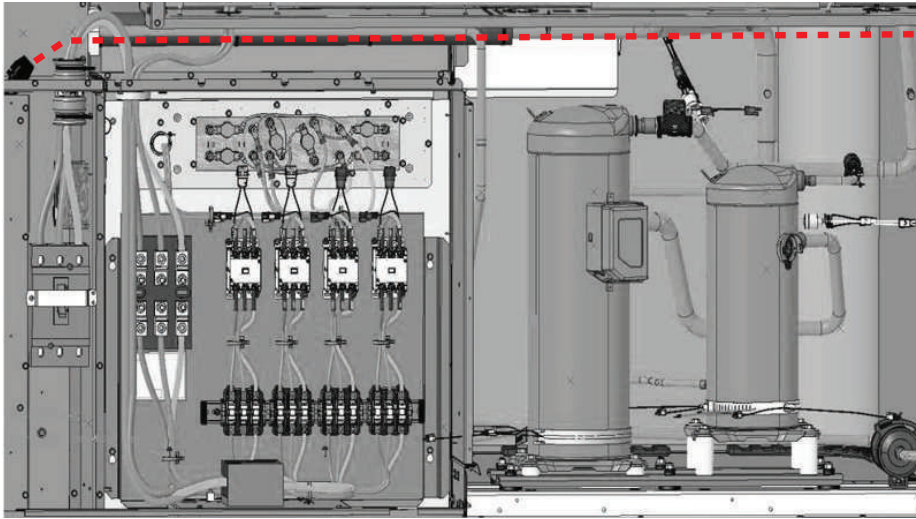

Figure 51. Main control panel low voltage wiring

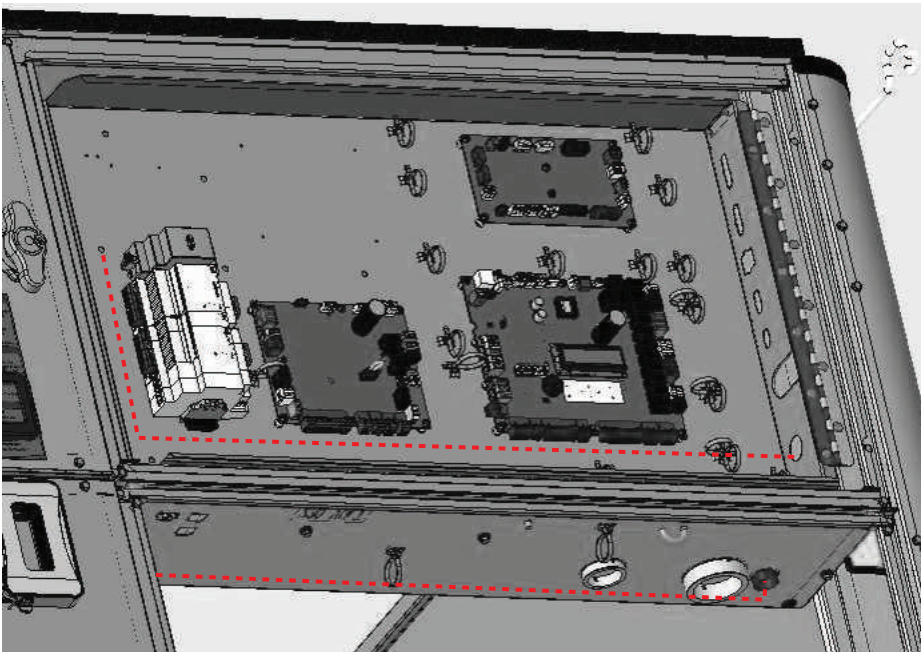

Table 4. Recommended wire lengths

Wire Size		Maximum recommended wire length from unit controller to sensor	
AWG	mm ²	Meters	Feet
22	0.33	0–46	0–150
20	0.50	47–73	151–240
18	0.75	74–117	241–385
16	1.30	118–185	386–610

Table 4. Recommended wire lengths (continued)

Wire Size		Maximum recommended wire length from unit controller to sensor	
AWG	mm ²	Meters	Feet
14	2.00	186–296	611–970

Note: The total resistance of these low voltage wires must not exceed 2.5 Ω /conductor. Any resistance greater than 2.5 Ω may cause the control to malfunction due to an excessive voltage drop.

Controls using DC Analog Input/Outputs (Standard Low Voltage Multi conductor Wire)

Before installing any connecting wiring between the unit and components utilizing a DC analog input/output signal, refer to the Dimensions and Weights chapter for the electrical access locations provided on the unit.

- Table 5, p. 40 lists the conductor sizing guidelines that must be followed when interconnecting the DC binary output devices and the system components utilizing a DC analog input/output signal to the unit.

Notes:

- Resistance in excess of 2.5 ohms per conductor can cause deviations in the accuracy of the controls.
- Ensure that the wiring between controls and the unit's termination point does not exceed two and a half (2.5) ohms/conductor for the length of the run.
- Do not run the electrical wires transporting DC signals in or around conduit housing high voltage wires.

DC Conductors

Table 5. Zone sensor module wiring

Distance from Unit to Control	Recommended Wire Size
0 - 150 feet	22 gauge
0 - 45.7 m	0.33 mm ²
151 - 240 feet	20 gauge
46 - 73.1 m	0.50 mm ²

Table 5. Zone sensor module wiring (continued)

Distance from Unit to Control	Recommended Wire Size
241 -385 feet	18 gauge
73.5 - 117.3 m	0.75 mm ²
386 - 610 feet	16 gauge
117.7 - 185.9 m	1.3 mm ²
611 - 970 feet	14 gauge
186.2 - 295.7 m	0.2 mm ²

Note: See Symbio™ 700 unit controls schematic, 1213-4349, for controls wiring.

Space Temperature Averaging

Space temperature averaging is accomplished by wiring a number of remote sensors in a series/parallel circuit.

Using the BAYSENS016* or BAYSENS077*, at least four sensors are required to accomplish space temperature averaging.

- Example #1 illustrates two series circuits with two sensors in each circuit wired in parallel. The square of any number of remote sensors is required.
- Example #2 illustrates three sensors squared in a series/parallel circuit. Using BAYSENS077*, two sensors are required to accomplish space temperature averaging.
- Example #3 illustrates the circuit required for this sensor. lists the temperature versus resistance coefficient for all sensors.

Figure 52. Examples

EXAMPLE #1

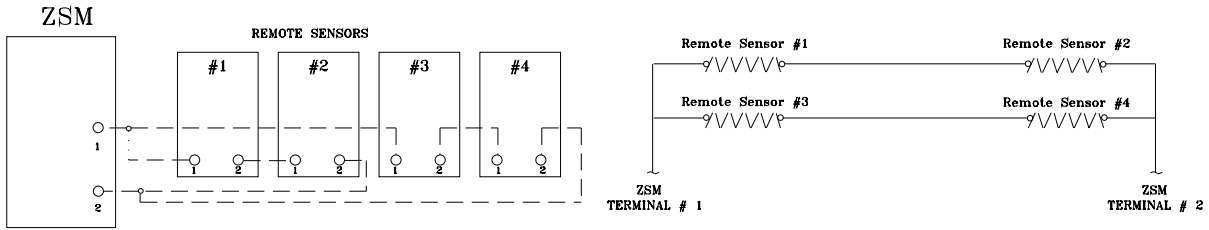

EXAMPLE #2

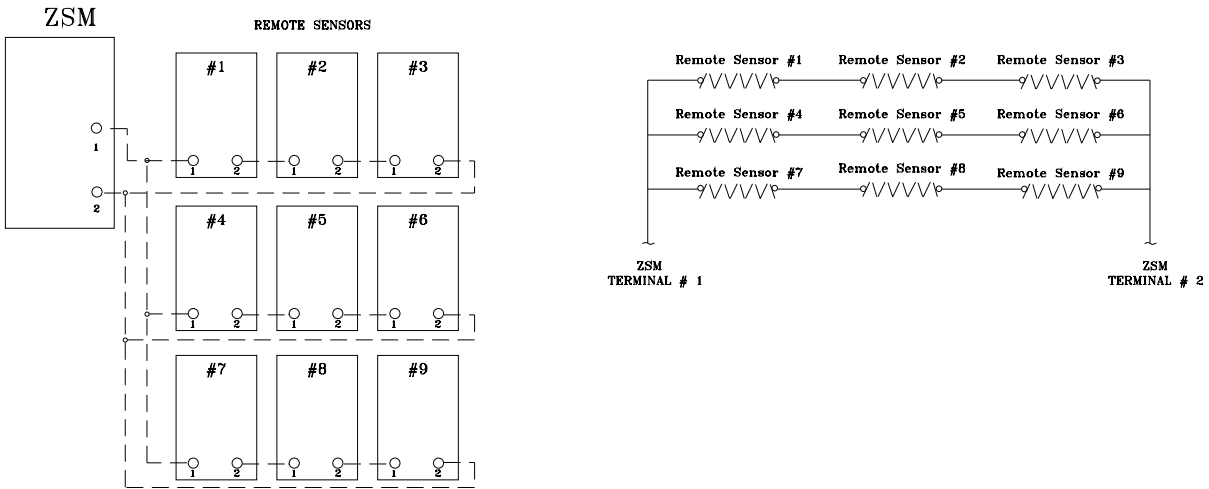

EXAMPLE #3

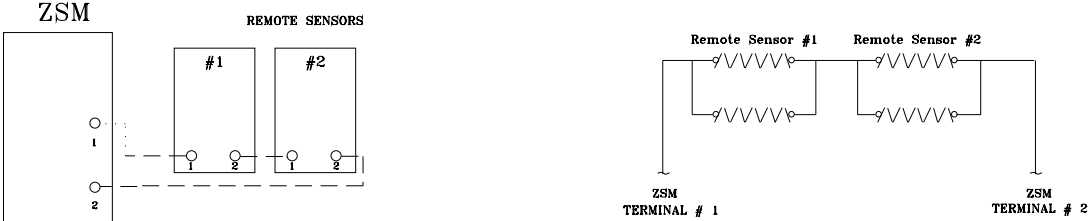

Note: Wiring pin numbers are for reference only. There are multiple smoke detector systems that could have differently numbered pins. For correct wiring details, please refer to the specific smoke detector literature that accompanied this unit.

Table 6. Temperature vs. resistance

Temperature		Nominal Resistance (kOhms)
Degrees °F	Degrees °C	
-20	-28.9	170.1
-15	-26.1	143.5
-10	-23.3	121.4
-5	-20.6	103.0
0	-17.8	87.56

Table 6. Temperature vs. resistance (continued)

Temperature		Nominal Resistance (kOhms)
Degrees °F	Degrees °C	
5	-15.0	74.65
10	-12.2	63.80
15	-9.4	54.66
20	-6.7	46.94
25	-3.8	40.40
30	-1.1	34.85
35	1.7	30.18
40°	4.4	26.22
45°	7.2	22.85

Table 6. Temperature vs. resistance (continued)

Temperature		Nominal Resistance (kOhms)
Degrees °F	Degrees °C	
50°	10.0	19.96
55°	12.8	17.47
60°	15.6	15.33
65°	18.3	13.4
70°	21.1	11.89

Table 6. Temperature vs. resistance (continued)

Temperature		Nominal Resistance (kOhms)
Degrees °F	Degrees °C	
75°	23.9	10.50
80°	26.7	9.297
85°	29.4	8.247
90°	32.2	7.330
95°	35.0	6.528

Pre-Start

Use the checklist provided below in conjunction with the “General Unit Requirements” checklist to ensure that the unit is properly installed and ready for operation.

⚠ WARNING

Hazardous Voltage w/Capacitors!
Failure to disconnect power and discharge capacitors before servicing could result in death or serious injury.
Disconnect all electric power, including remote disconnects and discharge all motor start/run capacitors before servicing. Follow proper lockout/tagout procedures to ensure the power cannot be inadvertently energized. Verify with a CAT III or IV voltmeter rated per NFPA 70E that all capacitors have discharged.

- Check all electrical connections for tightness and “point of termination” accuracy.
- Verify that the condenser airflow will be unobstructed.

⚠ WARNING

Rotating Components!
Failure to disconnect power before servicing could result in rotating components cutting and slashing technician which could result in death or serious injury.
During installation, testing, servicing and troubleshooting of this product it may be necessary to work with live and exposed rotating components. Have a qualified or licensed service individual who has been properly trained in handling exposed rotating components, perform these tasks.

- Verify that the condenser fan and indoor blower turn freely without rubbing and are properly tightened on the shafts.
- Verify that a condensate trap is installed and the piping is properly sized and pitched.
- Verify that the correct size and number of filters are in place.
- Inspect the interior of the unit for tools and debris and install all panels in preparation for starting the unit.

Voltage Imbalance

Three phase electrical power to the unit must meet stringent requirements for the unit to operate properly.

Measure each leg (phase-to-phase) of the power supply. Each reading must fall within the utilization range stamped on the unit nameplate. If any of the readings do not fall within the proper tolerances, notify the power company to correct this situation before operating the unit.

Excessive three phase voltage imbalance between phases will cause motors to overheat and eventually fail. The maximum allowable voltage imbalance is 2 percent. Measure and record the voltage between phases 1, 2, and 3 and calculate the amount of imbalance as follows:

$$\% \text{ Voltage Imbalance} = \frac{100 \times AV - VD}{AV} \text{ where;}$$

$$AV \text{ (Average Voltage)} = \frac{\text{Volt1} + \text{Volt2} + \text{Volt3}}{3}$$

- V1, V2, V3 = Line Voltage Readings
- VD = Line Voltage reading that deviates the farthest from the average voltage.

Example: If the voltage readings of the supply power measured 221, 230, and 227, the average volts would be:

$$\frac{221 + 230 + 221}{3} = 226 \text{ Avg.}$$

VD (reading farthest from average) = 221

The percentage of Imbalance equals:

$$\frac{100 + 226 + 221}{226} = 2.2\%$$

The 2.2 percent imbalance in this example exceeds the maximum allowable imbalance of 2.0 percent. This much imbalance between phases can equal as much as a 20 percent current imbalance with a resulting increase in motor winding temperatures that will decrease motor life. If the voltage imbalance is over 2 percent, notify the proper agencies to correct the voltage problem before operating this equipment.

Electrical Phasing (Three Phase Motors)

The compressor motor(s) and the supply fan motor are internally connected for the proper rotation when the incoming power supply is phased as A, B, C.

Proper electrical supply phasing can be quickly determined and corrected before starting the unit by using an instrument such as an Associated Research Model 45 Phase Sequence Indicator and following the steps below:

⚠ WARNING

Hazardous Voltage w/Capacitors!

Failure to disconnect power and discharge capacitors before servicing could result in death or serious injury.

Disconnect all electric power, including remote disconnects and discharge all motor start/run capacitors before servicing. Follow proper lockout/tagout procedures to ensure the power cannot be inadvertently energized. Verify with a CAT III or IV voltmeter rated per NFPA 70E that all capacitors have discharged.

1. Turn the field supplied disconnect switch that provides power to the main power terminal block or to the “Line” side of the optional factory mounted disconnect switch to the “Off” position.
2. Connect the phase sequence indicator leads to the terminal block or to the “Line” side of the optional factory mounted disconnect switch as follows;
 - Brown (phase A) to L1
 - Orange (phase B) to L2
 - Yellow (phase C) to L3
3. Close the field supplied main power disconnect switch or circuit protector switch that provides the supply power to the unit.

Note: Upon closing main power disconnect and the unit mounted disconnect switch or circuit breaker, the phase monitor will verify proper phasing. If LED on face of the monitor is red, correct supply power fault.

⚠ WARNING

Live Electrical Components!

Failure to follow all electrical safety precautions when exposed to live electrical components could result in death or serious injury.

When it is necessary to work with live electrical components, have a qualified licensed electrician or other individual who has been properly trained in handling live electrical components perform these tasks.

To prevent injury or death from electrocution, it is the responsibility of the technician to recognize this hazard and use extreme care when performing service procedures with the electrical power energized.

4. Observe the ABC and CBA phase indicator lights on the face of the sequencer. The ABC indicator light will glow if the phase is ABC. If the CBA indicator light glows, open the disconnect switch or circuit protection switch and reverse any two power wires.
5. Restore the main electrical power and recheck the phasing. If the phasing is correct, open the disconnect switch or circuit protection switch and remove the phase sequence indicator.

Compressor Crankcase Heaters

Each compressor can be equipped with a crankcase heater (On some units the crankcase heater comes standard). The proper operation of the crankcase heater is important to maintain an elevated compressor oil temperature during the “Off” cycle to reduce oil foaming during compressor starts.

Oil foaming occurs when refrigerant condenses in the compressor and mixes with the oil. In lower ambient conditions, refrigerant migration to the compressor could increase.

When the compressor starts, the sudden reduction in crankcase pressure causes the liquid refrigerant to boil rapidly causing the oil to foam. This condition could damage compressor bearings due to reduced lubrication and could cause compressor mechanical failures.

Before starting the unit in the “Cooling” mode, set the system switch to the “Off” position and turn the main power disconnect to the “On” position and allow the crankcase heater to operate a minimum of 8 hours.

Before closing the main power disconnect switch, insure that the “System” selection switch is in the “Off” position and the “Fan” selection switch is in the “Auto” position.

Close the main power disconnect switch and the unit mounted disconnect switch, if applicable.

Note: Upon closing main power disconnect and the unit mounted disconnect switch or circuit breaker, the phase monitor will verify proper phasing. If LED on face of the monitor is red, correct supply power fault.

⚠ WARNING

Live Electrical Components!

Failure to follow all electrical safety precautions when exposed to live electrical components could result in death or serious injury.

When it is necessary to work with live electrical components, have a qualified licensed electrician or other individual who has been properly trained in handling live electrical components perform these tasks.

To prevent injury or death from electrocution, it is the responsibility of the technician to recognize this hazard and use extreme care when performing service procedures with the electrical power energized.

Symbio Controls

The Symbio™ 700 supports a Service Test Mode that can be used to energize the various components of the system, either to support general system startup tasks or to support troubleshooting. The user can initiate Service Test Mode through the controller user interfaces, including the Symbio Service and Installation mobile application.

The modes shown below can be initiated. Depending on the equipment configuration, the controller will energize the

appropriate outputs. A user-selected timeout value will determine how long the controller will remain in any given state once initiated. For detailed information on how each Service Test State is interpreted based on the equipment's

configuration, see ACC-APG002*-EN, Symbio™ 700 for Precedent Packaged Rooftop Air-Conditioners Application Guide.

Figure 53. Symbio 700 service test mode

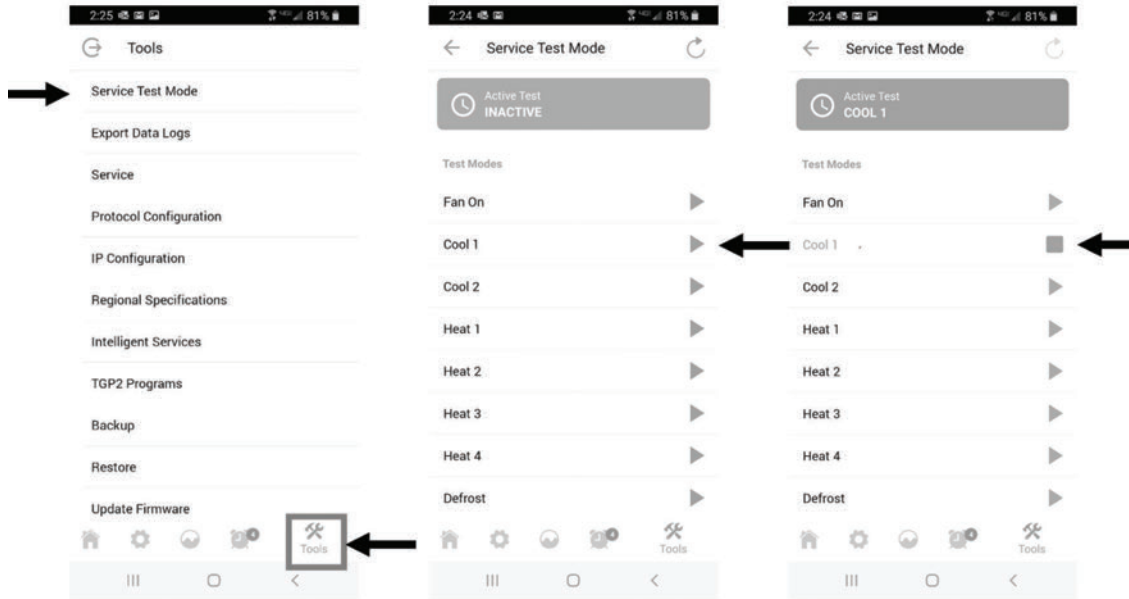

Unit Start-Up

Sequence of Operation

See ACC-APG002*-EN, Application Guide, Symbio™ 700 Controller with Precedent™ Packaged Rooftop Air-Conditioners.

Return Air Smoke Detector

The return air smoke detector is designed to shut off the unit if smoke is sensed in the return air stream. Sampling the airflow entering the unit at the return air opening performs this function.

In order for the smoke detector to properly sense smoke in the return air stream, the air velocity entering the unit must be between 500 and 4000 feet per minute. Equipment covered in this manual will develop an airflow velocity that falls within these limits over the entire airflow range specified in the evaporator fan performance tables.

Compressor Start-Up

⚠ WARNING

Live Electrical Components!

Failure to follow all electrical safety precautions when exposed to live electrical components could result in death or serious injury.

When it is necessary to work with live electrical components, have a qualified licensed electrician or other individual who has been properly trained in handling live electrical components perform these tasks.

1. Attach a set of service gauges onto the suction and discharge gauge ports for each circuit.
Proceed to the next Service Test step if continuing from previous component start-up or until the desired start-up component test is started.
2. After the compressor and condenser fan have started and operated for approximately 30 minutes, observe the operating pressures. Compare the operating pressures to the label on the access panel.
3. Check system superheat. Follow the instruction listed on the superheat charging curve in the Service Facts. Superheat should be within $\pm 5^{\circ}\text{F}$ of the superheat chart value.
4. Repeat steps 1 through 4 for each refrigerant circuit.
5. To stop the SERVICE TEST, turn the main power disconnect switch to the "Off" position or proceed to the next component start-up procedure. Remove electromechanical test mode connections (if applicable).

Hot Gas Reheat

⚠ WARNING

Live Electrical Components!

Failure to follow all electrical safety precautions when exposed to live electrical components could result in death or serious injury.

When it is necessary to work with live electrical components, have a qualified licensed electrician or other individual who has been properly trained in handling live electrical components perform these tasks.

Set the unit to Service Test step Reheat. Once the unit is in the reheat test mode, verify that the 3 way valve has shifted to the reheat position and that the supply temperature rises 10°F more than when in cooling mode stage 2.

Monitor the suction pressure for 15 minutes. The suction pressure should remain within 5 psi of normal cooling operation. If the unit has a 2 speed outdoor fan and if the outdoor air temperature is below 70°F , verify that the OD fan is in low speed.

1. Clamp an amp meter around one of 1st stage heater power wires at the heater contactor.
2. Using the Service Test Guide in [Figure 53, p. 45](#), continue the SERVICE TEST start-up procedure for each compressor circuit.

Select the next desired Service Test Mode if continuing from previous component start up or exit Service Test if complete.

Final System Setup

After completing all of the pre-start and startup procedures outlined in the previous sections (i.e., operating the unit in each of its modes through all available stages of cooling and heating), perform these final checks before leaving the unit:

- Program the Night Setback (NSB) panel (if applicable) for proper unoccupied operation. Refer to the programming instructions for the specific panel.
- Verify that the Remote panel "System" selection switch, "Fan" selection switch, and "Zone Temperature" settings for automatic operation are correct.
- Inspect the unit for misplaced tools, hardware, and debris.
- Verify that all exterior panels including the control panel doors and condenser grilles are secured in place.
- Close the main disconnect switch or circuit protector switch that provides the supply power to the unit's terminal block or the unit mounted disconnect switch.

⚠ WARNING

Safety Alert!

Failure to follow instructions below could result in death or serious injury.

In addition to the following tasks, you **MUST**:

- Follow all instructions in the unit's *Installation, Operation, and Maintenance* manual, including warnings, cautions, and notices.
- Perform all required tasks in any applicable Service Alerts and Service Bulletins.
- Review and understand all information provided in Submittals and Design Specifications.

Maintenance

⚠ WARNING

Hazardous Service Procedures!

Failure to follow all precautions in this manual and on the tags, stickers, and labels could result in death or serious injury.

Technicians, in order to protect themselves from potential electrical, mechanical, and chemical hazards, **MUST** follow precautions in this manual and on the tags, stickers, and labels, as well as the following instructions: Unless specified otherwise, disconnect all electrical power including remote disconnect and discharge all energy storing devices such as capacitors before servicing. Follow proper lockout/tagout procedures to ensure the power can not be inadvertently energized. When necessary to work with live electrical components, have a qualified licensed electrician or other individual who has been trained in handling live electrical components perform these tasks.

Monthly Maintenance

Before completing the following checks, turn the unit OFF and lock the main power disconnect switch open.

⚠ WARNING

Hazardous Voltage!

Failure to disconnect power before servicing could result in death or serious injury.

Disconnect all electric power, including remote disconnects before servicing. Follow proper lockout/tagout procedures to ensure the power can not be inadvertently energized. Verify that no power is present with a voltmeter.

Filters

Inspect the return air filters. Clean or replace them if necessary.

Return Air Smoke Detector Maintenance

Airflow through the unit is affected by the amount of dirt and debris accumulated on the indoor coil and filters. To insure that airflow through the unit is adequate for proper sampling by the return air smoke detector, complete adherence to the maintenance procedures, including recommended intervals between filter changes, and coil cleaning is required.

Periodic checks and maintenance procedures must be performed on the smoke detector to insure that it will function properly. For detailed instructions concerning these checks and procedures, refer to the appropriate section(s) of the smoke detector Installation and Maintenance Instructions provided with the literature package for this unit.

Condensate Overflow Switch

During maintenance, the switch float (black ring) must be checked to ensure free movement up and down.

Cooling Season

- Check the unit's drain pans and condensate piping to ensure that there are no blockages.
- Inspect the evaporator and condenser coils for dirt, bent fins, etc. If the coils appear dirty, clean them according to the instructions described in "Coil Cleaning" later in this section.
- Manually rotate the condenser fans to ensure free movement and check motor bearings for wear. Verify that all of the fan mounting hardware is tight.
- Inspect the F/A-R/A damper hinges and pins to ensure that all moving parts are securely mounted. Keep the blades clean as necessary.
- Verify that all damper linkages move freely; lubricate with white grease, if necessary.
- Check supply fan motor bearings; repair or replace the motor as necessary.
- Verify that all wire terminal connections are tight.
- Remove any corrosion present on the exterior surfaces of the unit and repaint these areas.
- Generally inspect the unit for unusual conditions (e.g., loose access panels, leaking piping connections, etc.)
- Make sure that all retaining screws are reinstalled in the unit access panels once these checks are complete.
- With the unit running, check and record the following:
 - ambient temperature
 - compressor suction and discharge pressures (each circuit)
 - superheat (each circuit)

Record this data on an "operator's maintenance log" like the one shown in [Table 8, p. 51](#). If the operating pressures indicate a refrigerant shortage, measure the system superheat. For guidelines, see "[Compressor Start-Up](#)," p. 46.

Important: *Do not release refrigerant to the atmosphere! If adding or removing refrigerant is required, the service technician must comply with all federal, state and local laws.*

Heating Season

- Inspect the unit's air filters. If necessary, clean or replace them.
- Check supply fan motor bearings; repair or replace the motor as necessary.
- Inspect both the main unit control panel and heat section control box for loose electrical components and

terminal connections, as well as damaged wire insulation. Make any necessary repairs.

- Verify that the electric heat system operates properly.

Coil Cleaning

Regular coil maintenance, including annual cleaning, enhances the unit's operating efficiency by minimizing the following:

- Compressor head pressure and amperage draw
- Evaporator water carryover
- Fan brake horsepower
- Due to increase static pressure losses
- Airflow reduction

⚠ WARNING

Hazardous Chemicals!

Failure to follow this safety precaution could result in death or serious injury. Coil cleaning agents can be either acidic or highly alkaline and can burn severely if contact with skin or eyes occurs.

Handle chemical carefully and avoid contact with skin. ALWAYS wear Personal Protective Equipment (PPE) including goggles or face shield, chemical resistant gloves, boots, apron or suit as required. For personal safety refer to the cleaning agent manufacturer's Materials Safety Data Sheet and follow all recommended safe handling practices.

At least once each year, or more often if the unit is located in a "dirty" environment, clean the condenser coils using the instructions outlined below. Be sure to follow these instructions as closely as possible to avoid damaging the coils.

Note: For units equipped with hail guards follow removal procedure listed below.

Hail Guard Removal

- Remove shipping screws (ones without washers).
- Lift hail guards up so screws with washers go to top of keyhole.
- Remove hailguard by sliding washer head screw through keyhole.

To clean refrigerant coils, use a soft brush and a sprayer (either a garden pump-up type or a high-pressure sprayer). A high-quality detergent is also required; suggested brands include "SPREX A.C.", "OAKITE 161", "OAKITE 166" and "COILOX". If the detergent selected is strongly alkaline (ph value exceeds 8.5), add an inhibitor.

Microchannel (MCHE) Coils

NOTICE

Coil Damage!

Failure to follow instructions below could result in coil damage.

DO NOT use any detergents with microchannel condenser coils.

Use pressurized water or air ONLY, with pressure no greater than 600psi.

For additional information regarding the proper microchannel coil cleaning procedure, refer to RT-SVB83*-EN

Due to the soft material and thin walls of the MCHE coils, the traditional field maintenance method recommended for Round Tube Plate Fin (RTPF) coils does not apply to microchannel coils. Moreover, chemical cleaners are a risk factor to MCHE due to the material of the coil. The manufacturer does not recommend the use of chemical cleaners to clean microchannel coils. Using chemical cleaners could lead to warranty claims being further evaluated for validity and failure analysis.

The recommended cleaning method for microchannel condenser coils is pressurized water or air with a non-pinpoint nozzle and an ECU of at least 180 with pressure no greater than 600 psi. To minimize the risk of coil damage, approach the cleaning of the coil with the pressure washer aimed perpendicular to the face of the coil during cleaning.

Note: For more details on microchannel coil cleaning, please refer to bulletin RT-SVB83*-EN.

Hail Guard Reinstallation

Reinstall hail guards by aligning the keyholes over the washer screw heads, and slide into place. If your installation requires seismic or special wind load compliance, reinstall shipping screws.

Hot Gas Reheat Additional Oil

NOTICE

Compressor Damage!

Use of incorrect refrigerant and oil could result in compressor damage and improper unit operation.

Use only refrigerant and oil specified on the unit nameplate.

Additional refrigerant oil has been added in the factory for all Hot Gas Reheat units. If major components (MCHE coil, valve assembly, etc.) are replaced or serviced, the following steps must be taken:

1. Measure the amount of oil removed during servicing.
2. When recharging the unit after servicing, replace the amount of oil removed, as measured in step 1. Verify oil added is the correct type.

Maintenance

3. For compressor replacements and/or additional questions, contact Technical Support.

Annual Maintenance

Clean and repaint any corroded surface.

Final Process

For future reference, record the unit data below in the blanks provided.

Table 7. Unit data log

Complete Unit Model Number	
Unit Serial Number	
Wiring Diagram Numbers (from unit control panel)	
Connections	
Schematics	

Table 8. Sample maintenance log

Date	Current Ambient Temp F/C	Refrigerant Circuit #1						Refrigerant Circuit #2					
		Compr. Oil Level	Suct. Press. Psig/kPa	Disch. Press Psig/kPa	Liquid Press Psig/kPa	Super-heat F/C	Sub-cool F/C	Compr. Oil Level	Suct. Press. Psig/kPa	Disch. Press Psig/kPa	Liquid Press Psig/kPa	Super-heat F/C	Sub-cool F/C
		- ok - low						- ok - low					
		- ok - low						- ok - low					
		- ok - low						- ok - low					
		- ok - low						- ok - low					
		- ok - low						- ok - low					
		- ok - low						- ok - low					

Note: Check and record the data requested above each month during the cooling season with the unit running.

Troubleshooting

Refer to the *Symbio™ 700 Controller with Precedent™ Packaged Rooftop Air-Conditioners Application Guide* (ACC-APG002*-EN).

Wiring Diagrams

Note: Wiring diagrams can be accessed using e-Library by entering the diagram number in the literature order

number search field or by contacting technical support.

Table 9. Wiring diagrams

Schematic Type	Controls	Voltage	Drawing Number	Description
Main Unit	Symbio 700	All	12134334	SCHEMATIC; SHEET 1, POWER, DUAL COMPRESSOR, DUAL CONDENSER FAN, STD SCCR
Main Unit	Symbio 700	All	12134335	SCHEMATIC; SHEET 1, POWER, DUAL COMPRESSOR, SINGLE CONDENSER FAN, HIGH SCCR
Main Unit	Symbio 700	All	12134336	SCHEMATIC; SHEET 1, POWER, DUAL COMPRESSOR, DUAL CONDENSER FAN, HIGH SCCR
Main Unit	Symbio 700	All	12134337	SCHEMATIC; SHEET 2, POWER, SINGLE INDOOR FAN, COOLING ONLY/ ELECTRIC HEAT, STD SCCR
Main Unit	Symbio 700	230V	12134338	SCHEMATIC; SHEET 2, POWER, SINGLE INDOOR FAN, 2-STAGE GAS HEAT, 230V, STD SCCR
Main Unit	Symbio 700	460V/575V	12134339	SCHEMATIC; SHEET 2, POWER, SINGLE INDOOR FAN, 2-STAGE GAS HEAT, 460V/575V, STD SCCR
Main Unit	Symbio 700	All	12134340	SCHEMATIC; SHEET 2, POWER, DUAL INDOOR FAN, COOLING ONLY/ ELECTRIC HEAT, STD SCCR
Main Unit	Symbio 700	230V	12134341	SCHEMATIC; SHEET 2, POWER, DUAL INDOOR FAN, 2-STAGE GAS HEAT, 230V, STD SCCR
Main Unit	Symbio 700	460V/575V	12134342	SCHEMATIC; SHEET 2, POWER, DUAL INDOOR FAN, 2-STAGE GAS HEAT, 460V/575V, STD SCCR
Main Unit	Symbio 700	All	12134343	SCHEMATIC; SHEET 2, POWER, SINGLE INDOOR FAN, COOLING ONLY/ ELECTRIC HEAT, HIGH SCCR
Main Unit	Symbio 700	230V	12134344	SCHEMATIC; SHEET 2, POWER, SINGLE INDOOR FAN, 2-STAGE GAS HEAT, 230V, HIGH SCCR
Main Unit	Symbio 700	460V/575V	12134345	SCHEMATIC; SHEET 2, POWER, SINGLE INDOOR FAN, 2-STAGE GAS HEAT, 460V/575V, HIGH SCCR
Main Unit	Symbio 700	All	12134346	SCHEMATIC; SHEET 2, POWER, DUAL INDOOR FAN, COOLING ONLY/ ELECTRIC HEAT, HIGH SCCR
Main Unit	Symbio 700	230V	12134347	SCHEMATIC; SHEET 2, POWER, DUAL INDOOR FAN, 2-STAGE GAS HEAT, 230V, HIGH SCCR
Main Unit	Symbio 700	460V/575V	12134348	SCHEMATIC; SHEET 2, POWER, DUAL INDOOR FAN, 2-STAGE GAS HEAT, 460V/575V, HIGH SCCR
Main Unit	Symbio 700	All	12134349	SCHEMATIC; SHEET 3, CONTROLS, SYMBIO 700 UNIT CONTROLS
Main Unit	Symbio 700	All	12134538	SCHEMATIC; SHEET 3, CONTROLS, SYMBIO 700 UNIT CONTROLS, HEAT PUMP
Main Unit	Symbio 700	All	12134443	SCHEMATIC; SHEET 4, CONTROLS, ADAPTER BOARD UNIT CONTROLS, DUAL COMPRESSOR, SINGLE FAN
Main Unit	Symbio 700	All	12134444	SCHEMATIC; SHEET 4, CONTROLS, ADAPTER BOARD UNIT CONTROLS, DUAL COMPRESSOR, DUAL FAN
Main Unit	Symbio 700	All	12134445	SCHEMATIC; SHEET 5, CONTROLS, INDOOR OPTIONS
Main Unit	Symbio 700	All	12134438	SCHEMATIC; SHEET 6, CONTROLS, FRESH AIR OPTIONS
Main Unit	Symbio 700	All	12134446	SCHEMATIC; SHEET 7, CONTROLS, CUSTOMER CONNECTION OPTIONS
Main Unit	Symbio 700	All	12134447	SCHEMATIC; SHEET 8, CONTROLS, STEPPER MOTOR CONTROLLER
Main Unit	Symbio 700	All	12134448	SCHEMATIC; SHEET 9, CONTROLS, XM30/XM32 EXPANSION MODULES

Wiring Diagrams

Table 9. Wiring diagrams (continued)

Schematic Type	Controls	Voltage	Drawing Number	Description
Main Unit	Symbio 700	All	X39004322	LABEL; FUSE TABLE
Component Location	Symbio 700	All	12134449	DIAGRAM; COMPONENT LOCATION, COOLING/ELECTRIC, B CABINET
Component Location	Symbio 700	All	12134450	DIAGRAM; COMPONENT LOCATION, GAS, B CABINET
Component Location	Symbio 700	All	12134451	DIAGRAM; COMPONENT LOCATION, COOLING/ELECTRIC, C CABINET
Component Location	Symbio 700	All	12134452	DIAGRAM; COMPONENT LOCATION, GAS, C CABINET
Component Location	Symbio 700	All	12134453	DIAGRAM; COMPONENT LOCATION, COOLING/ELECTRIC, D CABINET
Component Location	Symbio 700	All	12134454	DIAGRAM; COMPONENT LOCATION, GAS, D CABINET
Component Location	Symbio 700	All	12134539	DIAGRAM; COMPONENT LOCATION, COOLING/ELECTRIC, D CABINET, HEAT PUMP
Component Location	Symbio 700	All	12134540	DIAGRAM; COMPONENT LOCATION, GAS, D CABINET, DUAL FUEL
Electric Heat	Symbio 700	230V	12134301	SCHEMATIC; SHEET 1, ELECTRIC HEAT - 9 & 18 KW 240V
Electric Heat	Symbio 700	230V	12134302	SCHEMATIC; SHEET 1, ELECTRIC HEAT - 27 & 36 KW 240V
Electric Heat	Symbio 700	230V	12134303	SCHEMATIC; SHEET 1, ELECTRIC HEAT - 54 KW 240V
Electric Heat	Symbio 700	460V/575V	12134304	SCHEMATIC; SHEET 1, ELECTRIC HEAT - 9 & 18 KW 460V/575V
Electric Heat	Symbio 700	460V/575V	12134305	SCHEMATIC; SHEET 1, ELECTRIC HEAT - 27 & 36 KW 460V/575V
Electric Heat	Symbio 700	460V/575V	12134306	SCHEMATIC; SHEET 1, ELECTRIC HEAT - 54 KW 460V/575V
Electric Heat	Symbio 700	230V	12134307	SCHEMATIC; SHEET 1, ELECTRIC HEAT - 18 KW 240V
Electric Heat	Symbio 700	230V	12134308	SCHEMATIC; SHEET 1, ELECTRIC HEAT - 36 KW 240V
Electric Heat	Symbio 700	230V	12134309	SCHEMATIC; SHEET 1, ELECTRIC HEAT - 54 & 72 KW 240V
Electric Heat	Symbio 700	460V/575V	12134310	SCHEMATIC; SHEET 1, ELECTRIC HEAT - 18 KW 460V/575V
Electric Heat	Symbio 700	460V/575V	12134311	SCHEMATIC; SHEET 1, ELECTRIC HEAT - 36 KW 460V/575V
Electric Heat	Symbio 700	460V/575V	12134312	SCHEMATIC; SHEET 1, ELECTRIC HEAT - 54 & 72 KW 460V/575V
Electric Heat	Symbio 700	All	X39004311	LABEL; FUSE REPLACEMENT, ELECTRIC HEAT, 300V/600V
Supplimental	Symbio 700	All	12134327	DIAGRAM; POWER EXHAUST
Supplimental	Symbio 700	All	12134461	DIAGRAM; SCHEMATIC - CONVENIENCE OUTLET OPTION
Supplimental	Symbio 700	All	12134352	LABEL; DIAGRAM, LOW AMBIENT

Piping Diagrams

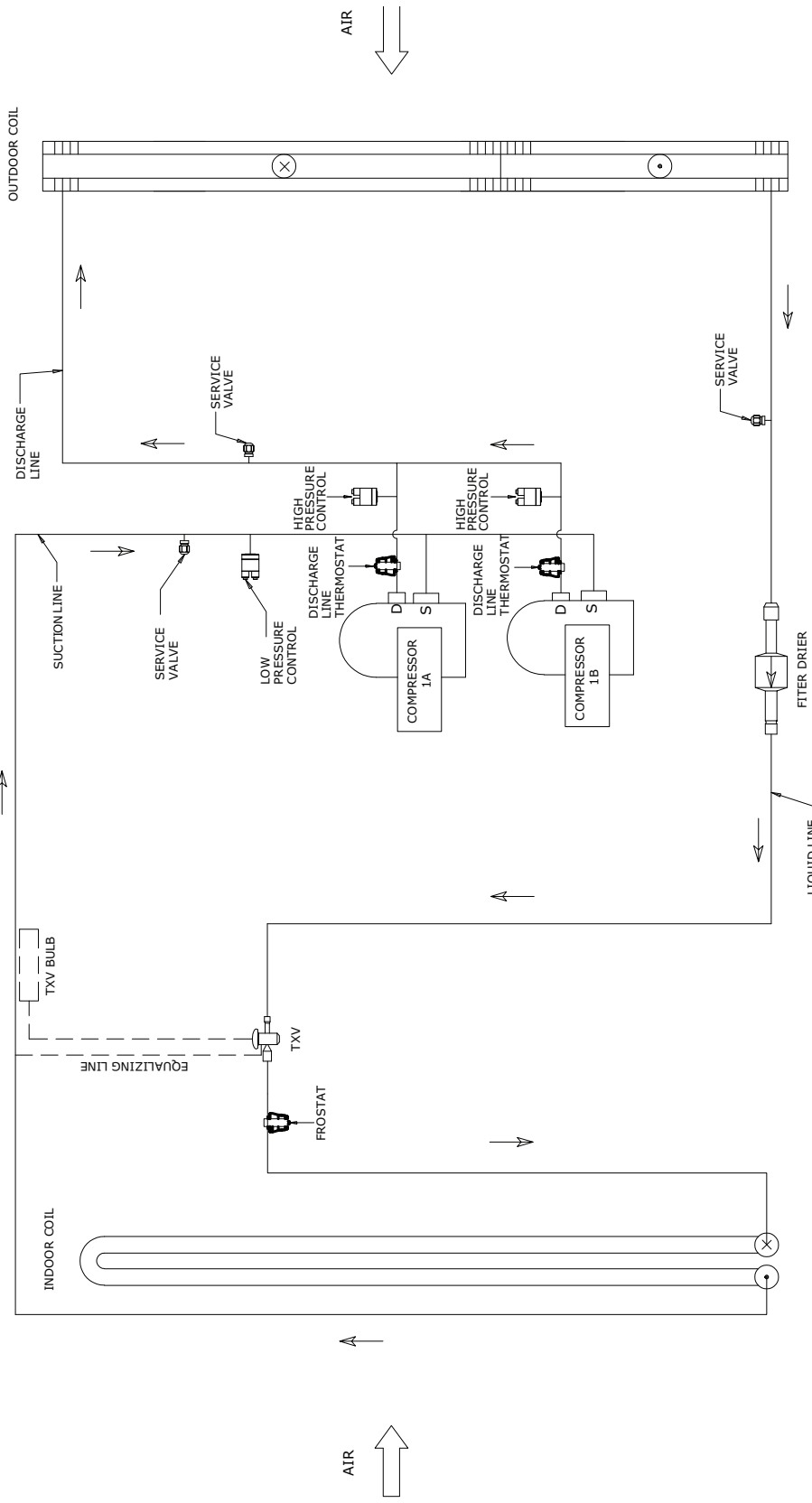

Figure 54. Piping diagram – 6 to 12.5 tons standard efficiency (TSJ072-150)

Figure 55. Piping diagram – 6 to 12.5 tons standard efficiency – hot gas reheat (TSJ072–150)

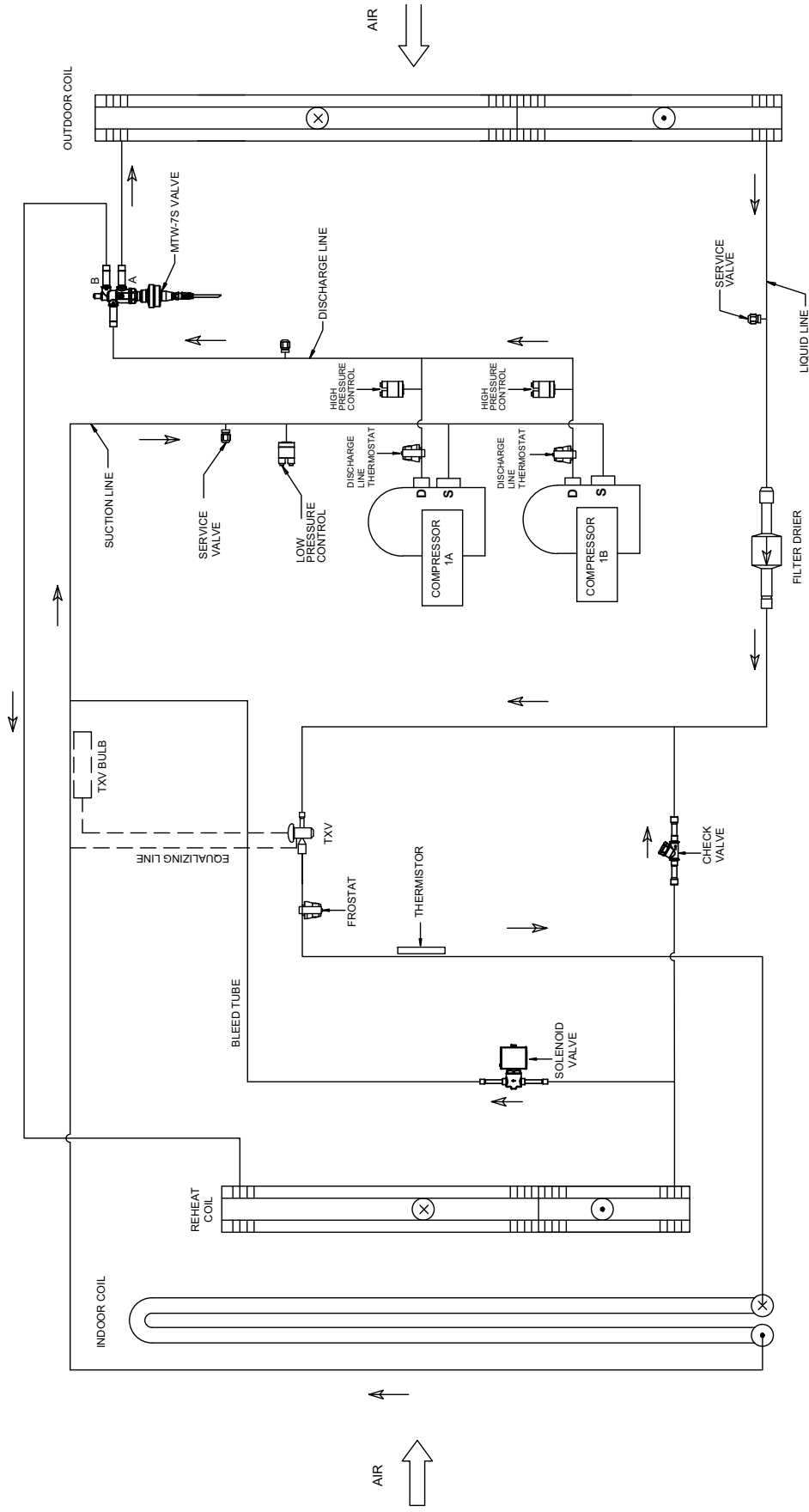

Figure 56. Piping diagram – 15 to 25 tons standard efficiency (TSJ180–300)

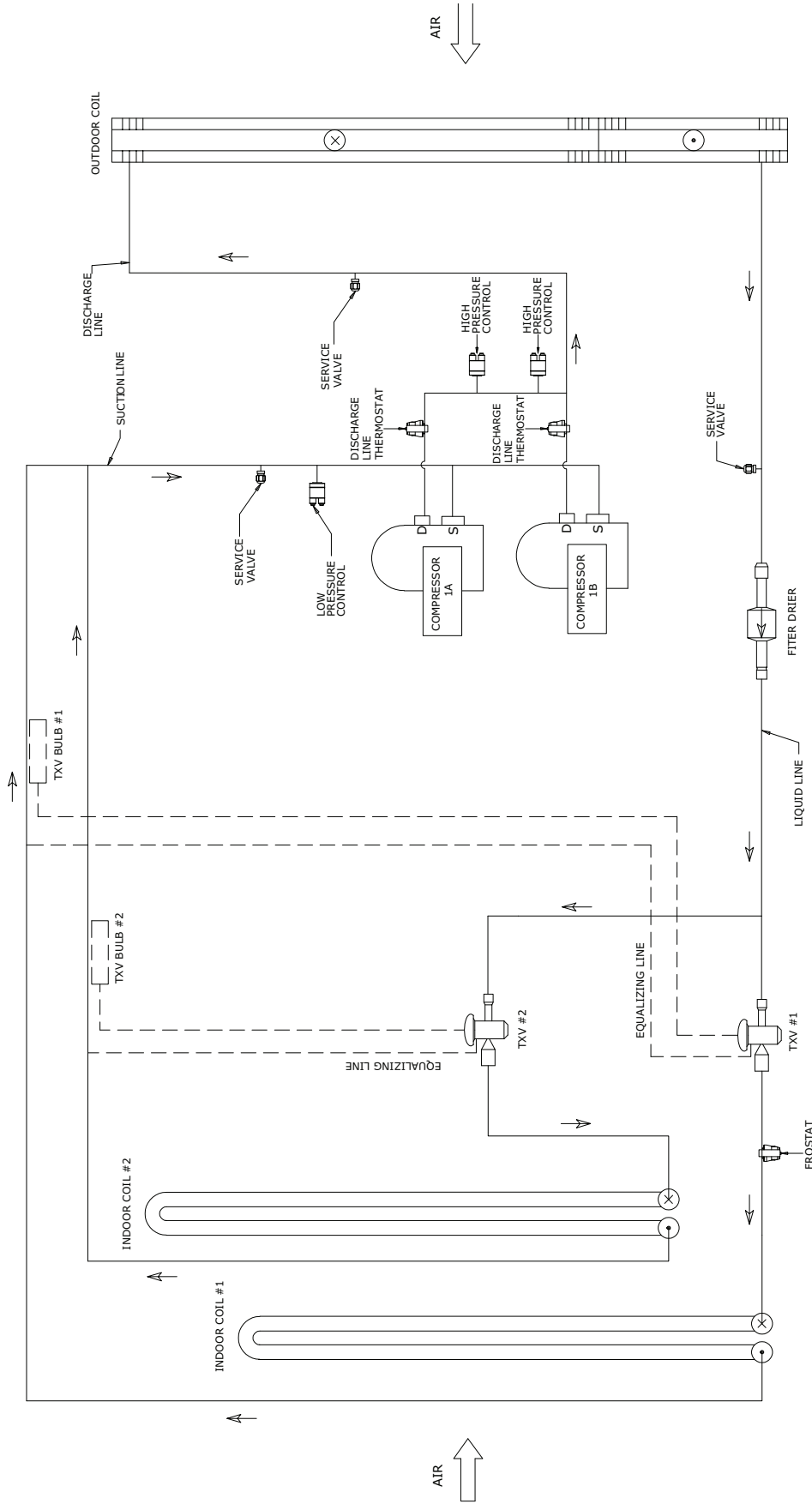
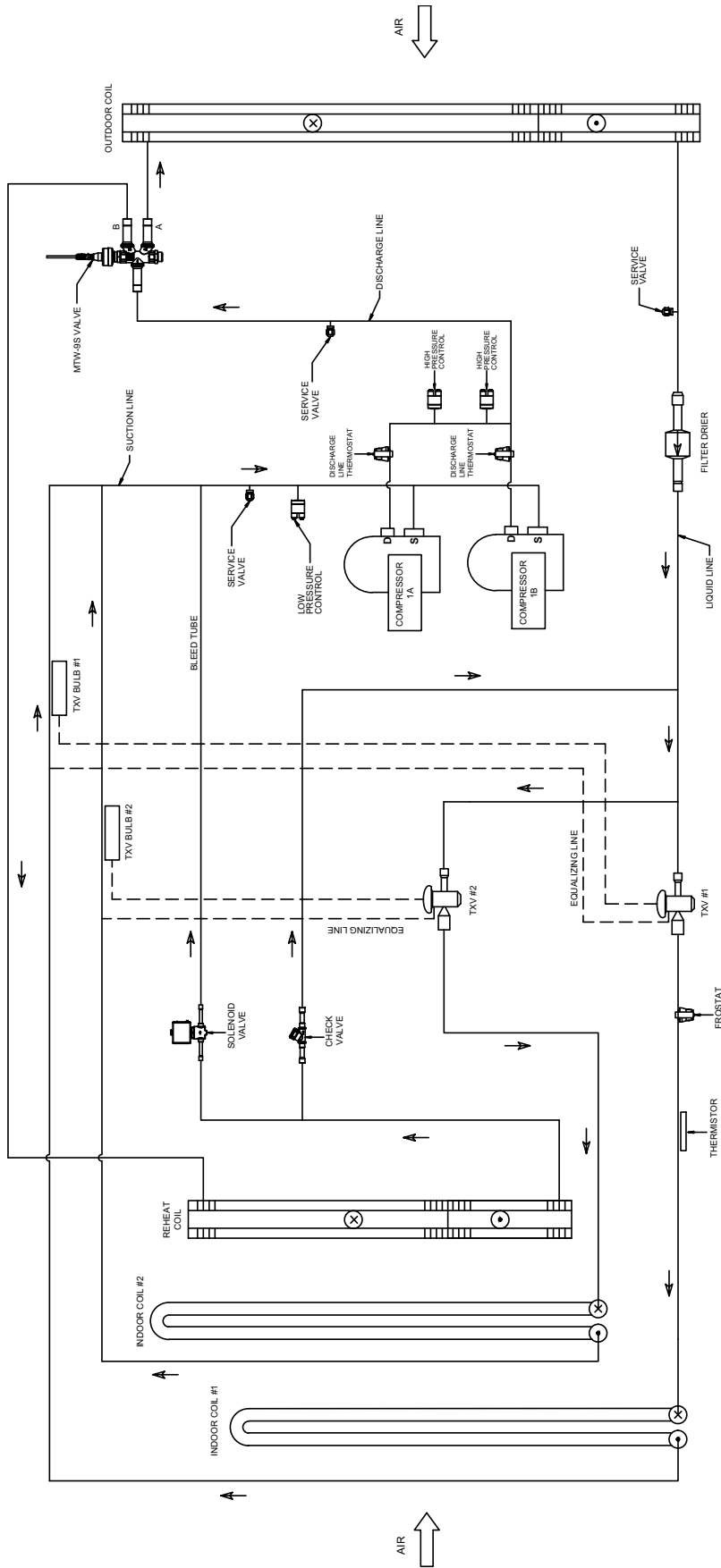

Figure 57. Piping diagram – 15 to 25 tons standard efficiency – hot gas reheat (TSJ180–300)



Limited Warranty

Electric Air Conditioner

TSJ Precedent Models

This warranty is extended by Trane to the original purchaser and to any succeeding owner of the real property to which the Electric/ Electric Air Conditioner is originally affixed and applies to products purchased and retained for use within the U.S.A. and Canada. The company warrants for a period of 36 months from initial start-up or 42 months from date of shipment, whichever is less, that the company products covered by this order (1) are free from defects in material and workmanship and (2) have the capacities and ratings set forth in the company's catalogs and bulletins.

There is no warranty against corrosion, erosion or deterioration. If any part of your Electric/ Electric Air Conditioner fails because of a manufacturing defect within three years (36 months) from the date of the original purchase, warrantor will furnish without charge the required replacement part.

In addition, if the sealed motor-**compressor** fails because of a manufacturing defect within the fourth through fifth year from the date of original purchase, warrantor will furnish without charge the required replacement compressor.

Warrantor's obligations and liabilities under this warranty are limited to furnishing F.O.B. warrantor factory or warehouse at warrantor designated shipping point, freight allowed to buyer's city, replacement parts for warrantor's products covered under this warranty. Warrantor shall not be obligated to pay for the cost of lost refrigerant. No liability shall attach to warrantor until products have been paid for and then liability shall be limited solely to the purchase price of the equipment under warranty shown to be defective.

THE WARRANTY AND LIABILITY SET FORTH HEREIN ARE IN LIEU OF ALL OTHER WARRANTIES AND LIABILITIES, WHETHER IN CONTRACT OR IN

NEGLIGENCE, EXPRESS OR IMPLIED, IN LAW OR IN FACT, INCLUDING IMPLIED WARRANTIES OF MERCHANTABILITY AND FITNESS FOR PARTICULAR USE, AND IN NO EVENT SHALL WARRANTOR BE LIABLE FOR ANY INCIDENTAL OR CONSEQUENTIAL DAMAGES.

Some states do not allow limitations on how long an implied warranty lasts or do not allow the exclusion or limitation of incidental or consequential damages, so the above limitation or exclusion may not apply to you. This warranty gives you specific legal rights, and you may also have other rights which vary from state to state.

Trane Technologies

2701 Wilma Rudolph Blvd.

Clarksville, TN 37040-1008

Attention: Manager, Product Service

GW-606-4800

The Company makes certain further warranty protection available on an optional extra-cost basis. Any further warranty must be in writing, signed by an officer of the company.

The warranty and liability set forth herein are in lieu of all other warranties and liabilities, whether in contract or in negligence, express or implied, in law or in fact, including implied warranties of merchantability and fitness for particular use. In no event shall the company be liable for any incidental or consequential damages.

* This warranty is for commercial usage of said equipment and not applicable when the equipment is used for a residential application. Commercial use is any application where the end purchaser uses the product for other than personal, family or household purposes.

**A five year limited warranty is provided for the optional "Low Leak" economizer.

Trane and American Standard create comfortable, energy efficient indoor environments for commercial and residential applications. For more information, please visit trane.com or americanstandardair.com.

Trane and American Standard have a policy of continuous product and product data improvement and reserve the right to change design and specifications without notice. We are committed to using environmentally conscious print practices.

RT-SVX070C-EN 30 May 2023
Supersedes RT-SVX070B-EN (September 2022)

©2023