

Installation, Operation, and Maintenance

Packaged Rooftop Air Conditioners

Foundation[®] Electric/Electric

15 to 22 Tons, 50Hz

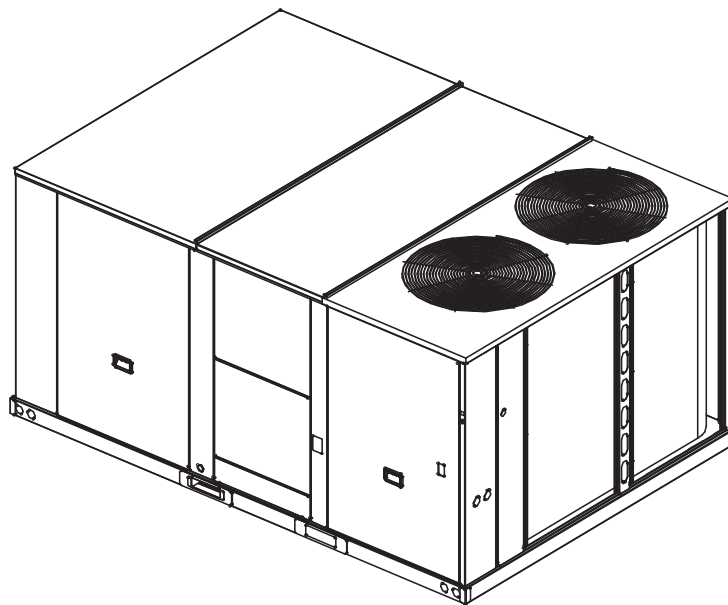

Model Numbers: EAC180-270AD

SAFETY WARNING

Only qualified personnel should install and service the equipment. The installation, starting up, and servicing of heating, ventilating, and air-conditioning equipment can be hazardous and requires specific knowledge and training. Improperly installed, adjusted or altered equipment by an unqualified person could result in death or serious injury. When working on the equipment, observe all precautions in the literature and on the tags, stickers, and labels that are attached to the equipment.

Introduction

Read this manual thoroughly before operating or servicing this unit.

Warnings, Cautions, and Notices

Safety advisories appear throughout this manual as required. Your personal safety and the proper operation of this machine depend upon the strict observance of these precautions.

The three types of advisories are defined as follows:

⚠ WARNING Indicates a potentially hazardous situation which, if not avoided, could result in death or serious injury.

⚠ CAUTION Indicates a potentially hazardous situation which, if not avoided, could result in minor or moderate injury. It could also be used to alert against unsafe practices.

NOTICE Indicates a situation that could result in equipment or property-damage only accidents.

Important Environmental Concerns

Scientific research has shown that certain man-made chemicals can affect the earth's naturally occurring stratospheric ozone layer when released to the atmosphere. In particular, several of the identified chemicals that may affect the ozone layer are refrigerants that contain Chlorine, Fluorine and Carbon (CFCs) and those containing Hydrogen, Chlorine, Fluorine and Carbon (HCFCs). Not all refrigerants containing these compounds have the same potential impact to the environment. Trane advocates the responsible handling of all refrigerants.

Important Responsible Refrigerant Practices

Trane believes that responsible refrigerant practices are important to the environment, our customers, and the air conditioning industry. All technicians who handle refrigerants must be certified according to local rules. For the USA, the Federal Clean Air Act (Section 608) sets forth the requirements for handling, reclaiming, recovering and recycling of certain refrigerants and the equipment that is used in these service procedures. In addition, some states or municipalities may have additional requirements that must also be adhered to for responsible management of refrigerants. Know the applicable laws and follow them.

⚠ WARNING

Proper Field Wiring and Grounding Required!

Failure to follow code could result in death or serious injury. All field wiring **MUST** be performed by qualified personnel. Improperly installed and grounded field wiring poses **FIRE** and **ELECTROCUTION** hazards. To avoid these hazards, you **MUST** follow requirements for field wiring installation and grounding as described in **NEC** and your local/state/national electrical codes.

⚠ WARNING

Personal Protective Equipment (PPE) Required!

Failure to wear proper PPE for the job being undertaken could result in death or serious injury. Technicians, in order to protect themselves from potential electrical, mechanical, and chemical hazards, **MUST** follow precautions in this manual and on the tags, stickers, and labels, as well as the instructions below:

- Before installing/servicing this unit, technicians **MUST** put on all PPE required for the work being undertaken (Examples; cut resistant gloves/sleeves, butyl gloves, safety glasses, hard hat/bump cap, fall protection, electrical PPE and arc flash clothing). **ALWAYS** refer to appropriate Safety Data Sheets (SDS) and OSHA guidelines for proper PPE.
- When working with or around hazardous chemicals, **ALWAYS** refer to the appropriate SDS and OSHA/GHS (Global Harmonized System of Classification and Labeling of Chemicals) guidelines for information on allowable personal exposure levels, proper respiratory protection and handling instructions.
- If there is a risk of energized electrical contact, arc, or flash, technicians **MUST** put on all PPE in accordance with OSHA, NFPA 70E, or other country-specific requirements for arc flash protection, **PRIOR** to servicing the unit. **NEVER PERFORM ANY SWITCHING, DISCONNECTING, OR VOLTAGE TESTING WITHOUT PROPER ELECTRICAL PPE AND ARC FLASH CLOTHING. ENSURE ELECTRICAL METERS AND EQUIPMENT ARE PROPERLY RATED FOR INTENDED VOLTAGE.**

⚠ WARNING

Follow EHS Policies!

Failure to follow instructions below could result in death or serious injury.

- All Trane personnel must follow the company's Environmental, Health and Safety (EHS) policies when performing work such as hot work, electrical, fall protection, lockout/tagout, refrigerant handling, etc. Where local regulations are more stringent than these policies, those regulations supersede these policies.
- Non-Trane personnel should always follow local regulations.

Copyright

This document and the information in it are the property of Trane, and may not be used or reproduced in whole or in part without written permission. Trane reserves the right to revise this publication at any time, and to make changes to its content without obligation to notify any person of such revision or change.

Trademarks

All trademarks referenced in this document are the trademarks of their respective owners.

Revision History

Updated publication company mark.

Table of Contents

Model Number Description	5	Compressor Crankcase Heaters	17
Model Number Notes	5	Checklist	18
General Information	6	Pre-Start	19
Unit Inspection	6	Verifying Proper Air Flow (Units with Belt Drive In- door Fan)	19
Precautionary Measures	6	Electromechanical Controls Test Procedure	19
Storage	6	Start-Up	20
Unit Description	7	Sequence of Operation	20
System Input Devices and Functions	7	Electromechanical Controls	20
Drain Pan Condensate Overflow Switch (Option- al)	7	Compressor Start-Up	20
Phase Monitor	7	Heating Start-Up	21
Discharge Line Thermostat Control	7	Final System Set Up	21
Evaporator Frost Control (Optional)	7	Maintenance	22
Locking Safety Device with Anti-Short Cycle Timer	7	Fan Belt Adjustment — Belt Drive Units	22
Sensors	7	Monthly Maintenance	23
High Temperature Sensor (BAYFRST003*)	7	Filters	23
Thermostat (TCONT802AS32DA)	7	Condensate Overflow Switch	23
Thermostat (TCONT402AN32DA)	7	Cooling Season	23
CO ₂ Sensor	7	Heating Season	23
Dimensional Data	8	Condenser Coil Cleaning	23
Unit Weights	13	Final Process	24
Rigging	13	Troubleshooting	25
Installation	14	Standard Troubleshooting	25
Unit Foundation	14	Failures	25
Horizontal Units	14	Resetting Cooling and Heating Lockouts	25
Ductwork	14	Method 1	25
General Unit Requirements	14	Method 2	25
Main Electrical Power Requirements	15	Condensate Overflow Switch	25
Electric Heat Requirements	15	Wiring Diagrams	26
Condensate Drain Configuration	15	Warranty	27
Filter Installation	15	Central Air Conditioner	27
Field Installed Power Wiring	15	EAC, EAD (Parts Only)	27
Main Unit Power	15		
Standard Wiring	15		
Control Power Transformer	16		
Controls using 24 Vac	16		
Voltage Imbalance	16		
Electrical Phasing (Three Phase Motors) ..	17		

Model Number Description

E	A	C	1	8	0	A	D	E	N	A	0	0
1	2	3	4	5	6	7	8	9	10	11	12	13

Digit 1 — Unit Type

E = Packaged Cooling, Electric Heat

Digit 2 — Efficiency

A = ASHRAE 90.1 - 2010

Digit 3 — Airflow Configuration

C = Convertible

Digit 4, 5, 6 — Nominal Gross Cooling Capacity (MBh)

180 = 15 Tons

210 = 17½ Tons

240 = 20 Tons

270 = 22 Tons

Digit 7 — Major Design Sequence

A

Digit 8 — Voltage Selection

D = 380-415/50/3

Digit 9 — Unit Controls

E = Electromechanical

Digit 10 — Heating Capacity

0 = No Heat

N = 27kW @ 50Hz

P = 41kW @ 50Hz

R = 54kW @ 50Hz

Digit 11 — Minor Design Sequence

Digit 12, 13 — Service Sequence

00 = None

Digit 14 — Fresh Air Selection

0 = No Fresh Air

A = Manual Outside Air Damper
0–25%

Digit 15 — Supply Fan/Drive Type/Motor

0 = Standard Motor

1 = Oversized Motor

Digit 16 — Not Used

Digit 17 — Condenser Coil Protection

0 = Standard Coil

4 = CompleteCoat™ Condenser Coil

Digit 18 — Through The Base Provisions

0 = No Through The Base Provisions

Digit 19 — Disconnect Switch

0 = No Disconnect

Digit 20 — Not Used

Digit 21 — Not Used

Digit 22 — Not Used

Digit 23 — Not Used

Digit 24 — Not Used

Digit 25 — System Monitoring Controls

0 = No Monitoring Controls

A = Condensate Drain Pan Overflow
Switch

Model Number Notes

1. Some field set up required.
2. Must be ordered with Through-the-Base Electrical option.

General Information

Unit Inspection

As soon as the unit arrives at the job site:

- Verify that the nameplate data matches the data on the sales order and bill of lading (including electrical data).
- Verify that the power supply complies with the unit nameplate specifications.
- Visually inspect the exterior of the unit, including the roof, for signs of shipping damage.
- Visually inspect the internal components for shipping damage as soon as possible after delivery and before it is stored. Do not walk on the sheet metal base pans.
- If concealed damage is discovered, notify the carriers terminal of damage immediately by phone and by mail. Concealed damage must be reported within 15 days.
 - Request an immediate joint inspection of the damage by the carrier and the consignee.
 - Do not remove damaged material from the receiving location.
 - Take photos of the damage, if possible. The owner must provide reasonable evidence that the damage did not occur after delivery.
- Notify the appropriate sales representative before installing or repairing a damaged unit.

Precautionary Measures

⚠ WARNING
Fiberglass Wool! Exposure to glass wool fibers without all necessary PPE equipment could result in cancer, respiratory, skin or eye irritation, which could result in death or serious injury. Disturbing the insulation in this product during installation, maintenance or repair will expose you to airborne particles of glass wool fibers and ceramic fibers known to the state of California to cause cancer through inhalation. You MUST wear all necessary Personal Protective Equipment (PPE) including gloves, eye protection, a NIOSH approved dust/mist respirator, long sleeves and pants when working with products containing fiberglass wool.
Precautionary Measures: <ul style="list-style-type: none">• Avoid breathing fiberglass dust.• Use a NIOSH approved dust/mist respirator.• Avoid contact with the skin or eyes. Wear long-sleeved, loose-fitting clothing, gloves, and eye protection.• Wash clothes separately from other clothing; rinse washer thoroughly.• Operations such as sawing, blowing, tear-out, and spraying may generate fiber concentrations requiring additional respiratory protection. Use the appropriate NIOSH approved respirator.
First Aid Measures: <ul style="list-style-type: none">• Eye Contact - Flush eyes with water to remove dust. If symptoms persist, seek medical attention.• Skin Contact - Wash affected areas gently with soap and warm water after handling.

Storage

Take precautions to prevent condensate from forming inside the units electrical compartments and motors if:

- The unit is stored before it is installed; or,
- The unit is set on the roof curb, and temporary heat is provided in the building. Isolate all side panel service entrances and base pan openings (e.g., conduit holes, S/A and R/A openings, and flue openings) from the ambient air until the unit is ready for start-up.

Note: Do not use the units heater for temporary heat without first completing the start-up procedure detailed under "Start-Up," p. 20.

The manufacturer will not assume any responsibility for equipment damage resulting from condensate accumulation on the units electrical and/or mechanical components.

Unit Description

Before shipment, each unit is leak tested, dehydrated, charged with refrigerant and compressor oil, and run tested for proper control operation.

Direct-drive, vertical discharge condenser fans are provided with built-in thermal overload protection.

System Input Devices and Functions

The unit must have a thermostat input in order to operate.

The descriptions of the following basic input devices used within the unit are to acquaint the operator with their function as they interface with the various features.

Refer to the units electrical schematic for the specific device connections. The following controls are available from the factory for field installation.

Drain Pan Condensate Overflow Switch (Optional)

This input incorporates the Condensate Overflow Switch (COF) mounted on the drain pan. When the condensate level reaches the trip point, the COF relay energizes and opens the 24 Vac control circuit, disabling the unit. A delay timer prevents the unit from starting for 3 minutes.

Phase Monitor

The Phase Monitor is a three-phase line monitor module that protects against phase loss, phase reversal and phase unbalance. It is intended to protect compressors from reverse rotation. It has an operating input voltage range of 190–600 Vac, and LED indicators for ON and FAULT. There are no field adjustments and the module will automatically reset from a fault condition.

Discharge Line Thermostat Control

The high pressure controls and the discharge line thermostats signals are wired in series and connected to safety input of LSD. The compressor contactor coil is connected at the CC terminal of the LSD. If the high pressure control switch or the discharge line thermostat is open, the 24 Vac signal to SI input of LSD is interrupted and the compressor contactor coil supply is disabled by LSD. It has an automatic lockout.

Evaporator Frost Control (Optional)

This input incorporates the Frostat™ control (FOS) mounted in the indoor coil and can be activated by closing a field supplied contact installed in parallel with the FOS.

If this circuit is open before the compressor is started, the compressor will not be allowed to operate. Anytime this circuit is opened for 5 continuous seconds during compressor operation, the compressor for that circuit is immediately turned **Off**. The compressor will not be allowed to restart for a minimum of 3 minutes should the FOS close.

Locking Safety Device with Anti-Short Cycle Timer

This device monitors compressor safety switch trips to prevent short cycling, protecting the compressor. A manual reset is required after a fourth safety switch trip.

Sensors

High Temperature Sensor (BAYFRST003*)

This sensor connects to the Emergency Stop Input on the LTB and provides high limit shutdown of the unit. The sensor is used to detect high temperatures due to fire in the air conditioning or ventilation ducts. The sensor is designed to mount directly to the sheet metal duct. Each kit contains two sensors. The return air duct sensor (X1310004001) is set to open at 135°F.

The supply air duct sensor (X1310004002) is set to open at 240°F. The control can be reset after the temperature has been lowered approximately 25°F below the cutout setpoint.

Thermostat (TCONT802AS32DA)

This thermostat is a multi-stage 3 heat/2 cool, auto-changeover digital display thermostat. It is a programmable thermostat, and a 7-day programmable stat with night setback shall be available. In addition, it is wall mounted.

Thermostat (TCONT402AN32DA)

This thermostat is a multi-stage 3 heat/2 cool, auto changeover digital display thermostat. It is a non-programmable, wall-mounted thermostat, and it can be used for economizer operation.

CO₂ Sensor

This optional sensor can be added for Demand Control Ventilation (DCV) functionality.

On units with a low leak economizer, configure the JADE controller by setting the following parameters:

SETPOINTS Menu:

DCV SET = desired CO₂ ppm to start DCV

VENTMAX = desired maximum position w/DCV and occupied status (2-speed applications require LO and HI settings)

VENTMIN = desired minimum position w/DCV and occupied status (2-speed applications require LO and HI settings)

ADVANCED SETUP Menu:

CO₂ ZERO = set to detectors start level

CO₂ SPAN = detector's max level minus start level

Attach the sensor to the CO₂ and R terminals (at customer connections).

Note: When using any 0-10 Vdc CO₂ sensor with the JADE you will need to set CO₂ ZERO to 400 ppm and the CO₂ SPAN to 1600 ppm in the ADVANCED SETUP menu.

Dimensional Data

Figure 1, p. 8 illustrates the minimum operating and service clearances for either a single or multiple unit installation. These clearances are the minimum distances necessary to assure adequate serviceability, cataloged unit capacity, and peak operating efficiency.

Providing less than the recommended clearances may result in condenser coil starvation, short-circuiting of exhaust and economizer airflows, or recirculation of hot condenser air.

Figure 1. Typical installation clearance for single and multiple unit applications

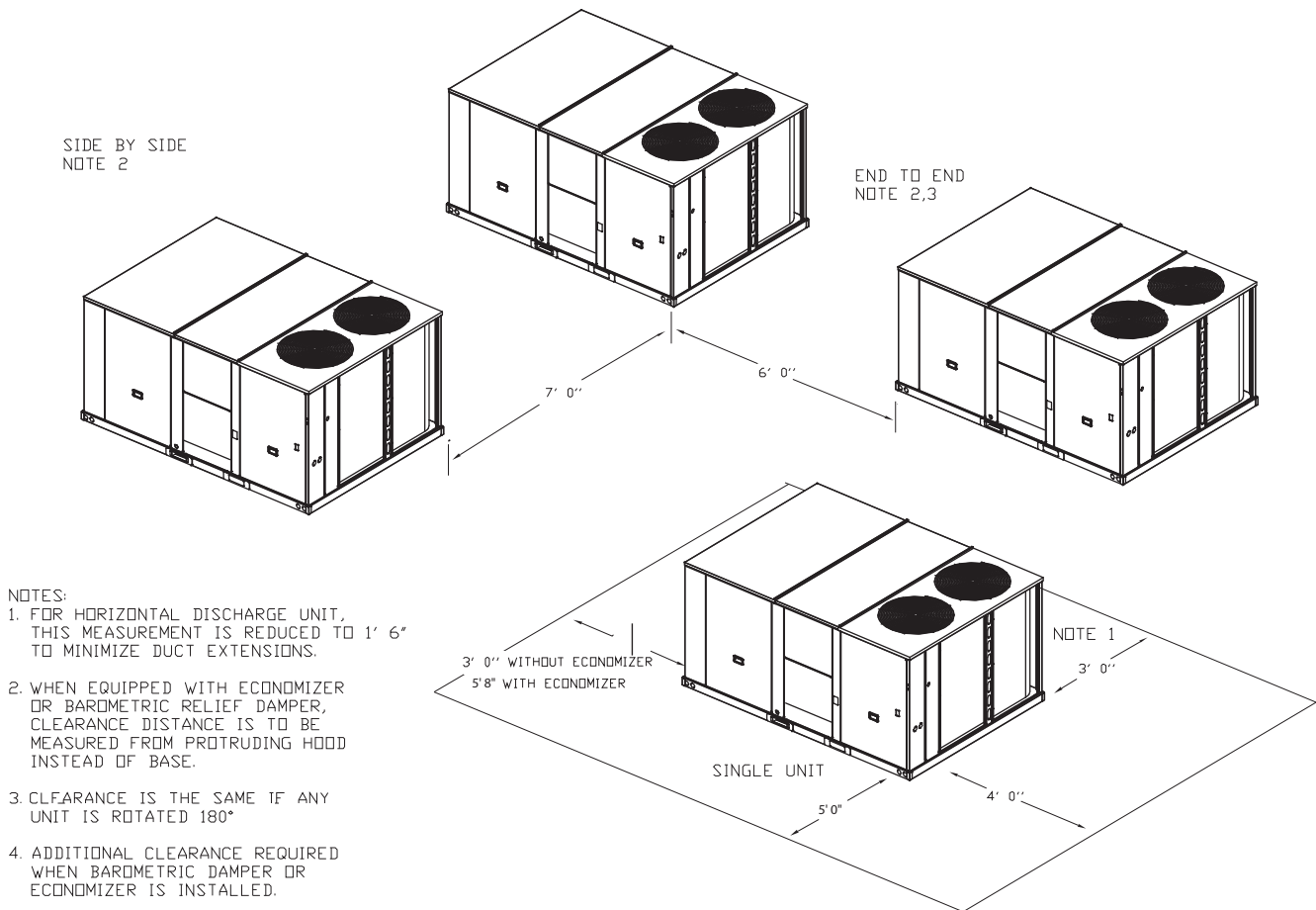

Figure 2. Cooling with optional electrical heat units — overview

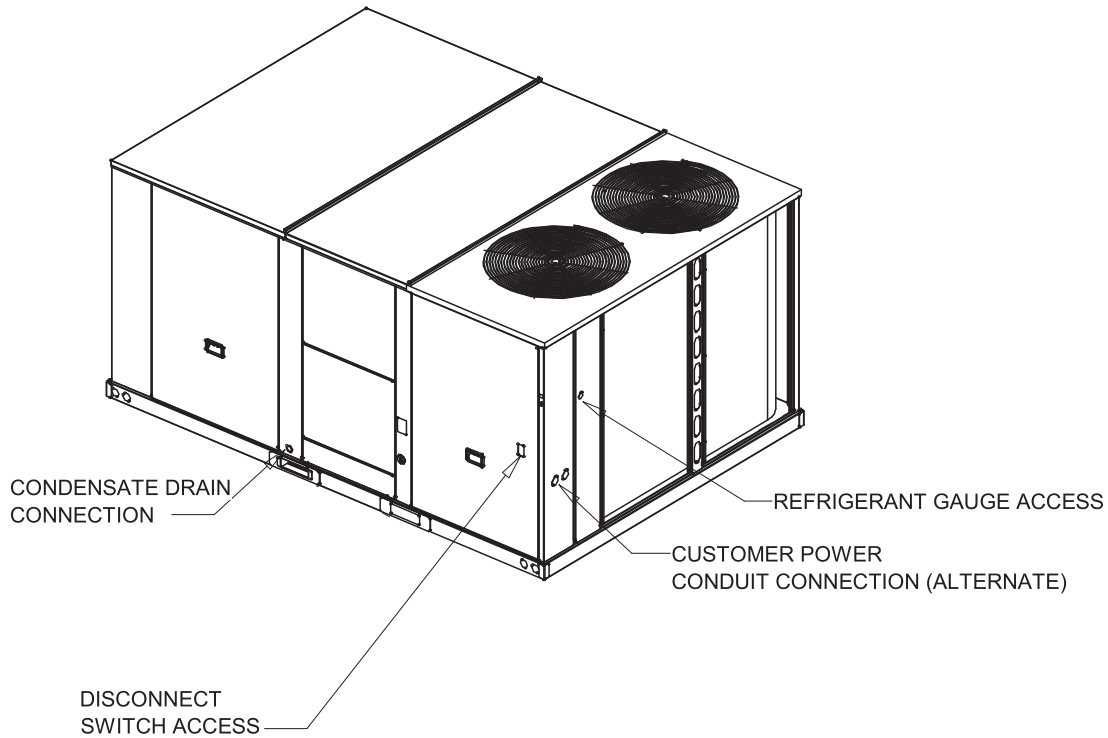
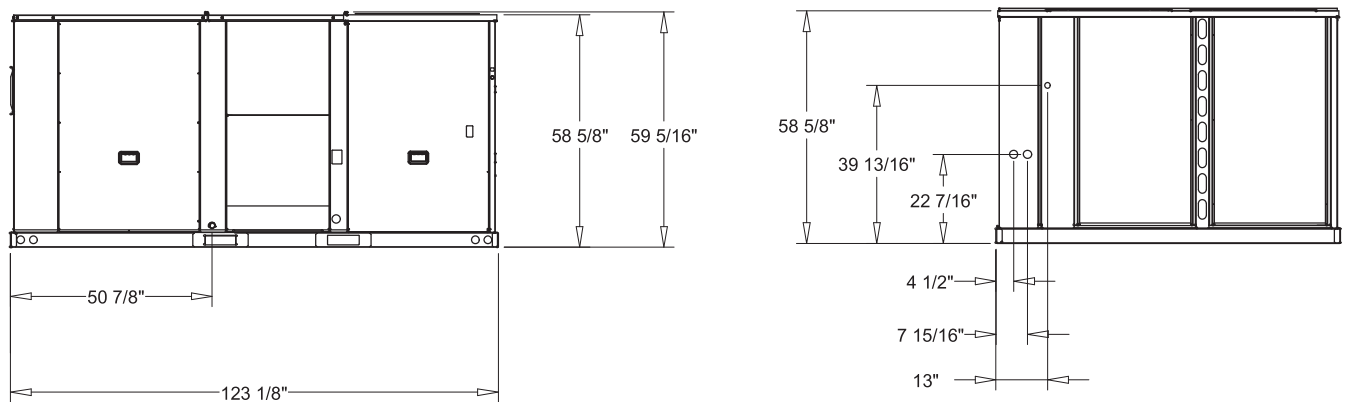

Figure 3. Cooling with optional electrical units — front and side views — 15 to 22 tons standard efficiency



NOTES:

1. THRU -THE -BASE ELECTRICAL IS NOT STANDARD ON ALL UNITS.
2. VERIFY WEIGHT, CONNECTION, AND ALL DIMENSION WITH INSTALLER DOCUMENTS BEFORE INSTALLATION

Dimensional Data

Figure 4. Cooling with optional electrical heat units — plan view — 15 to 22 tons standard efficiency

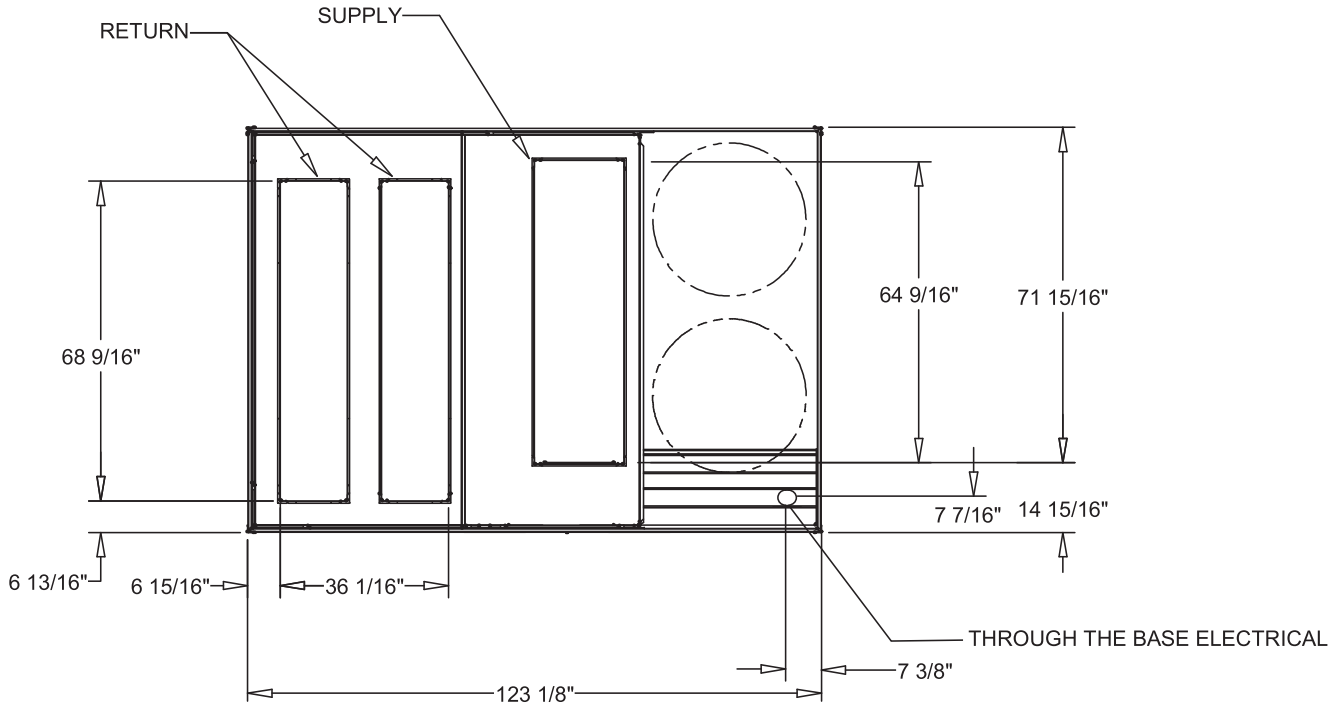

NOTES:

1. THRU -THE -BASE ELECTRICAL IS NOT STANDARD ON ALL UNITS.
2. VERIFY WEIGHT, CONNECTION, AND ALL DIMENSION WITH INSTALLER DOCUMENTS BEFORE INSTALLATION

Figure 5. Foundation units — back view (horizontal configuration) — 15 to 22 tons standard efficiency

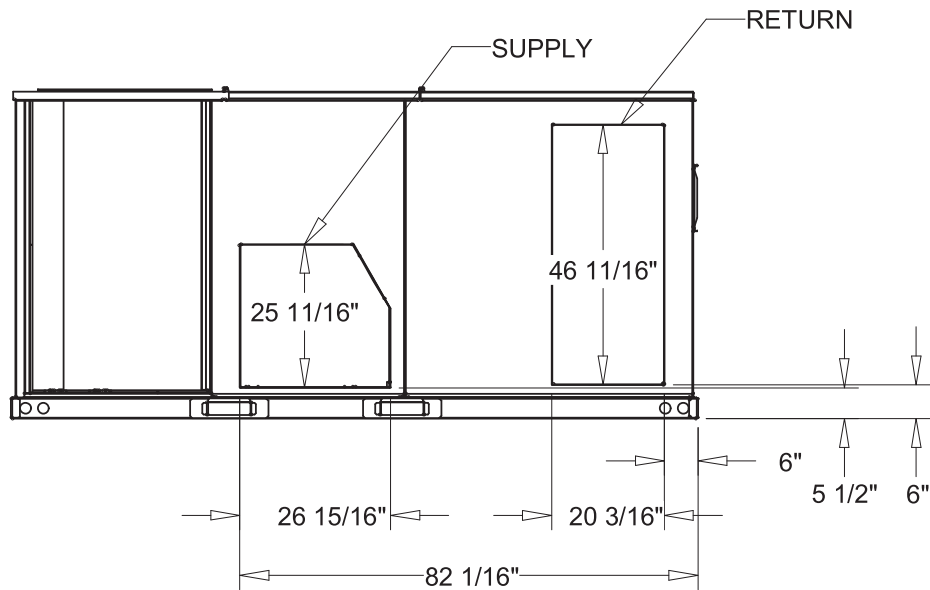

Figure 6. Roof curb — 15 to 22 tons standard efficiency

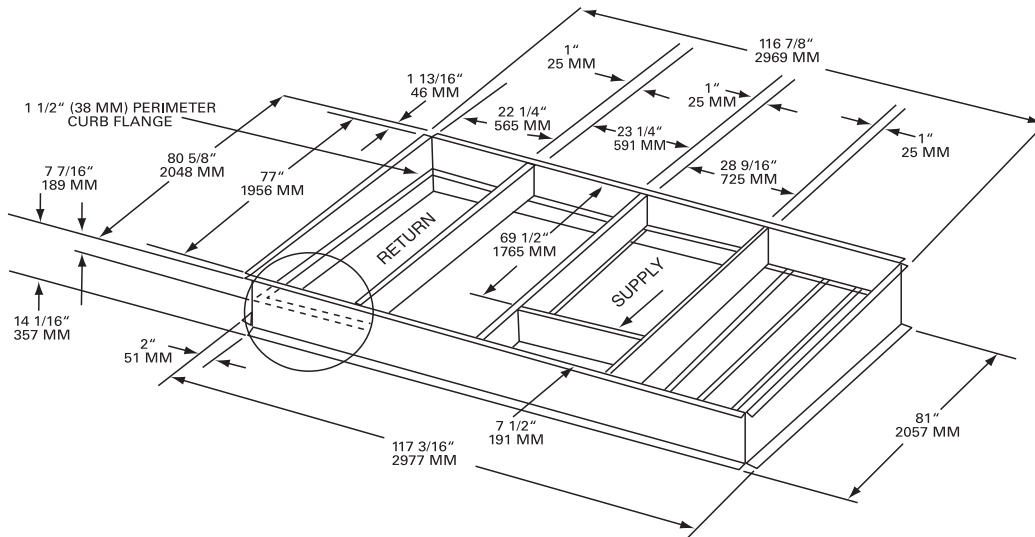
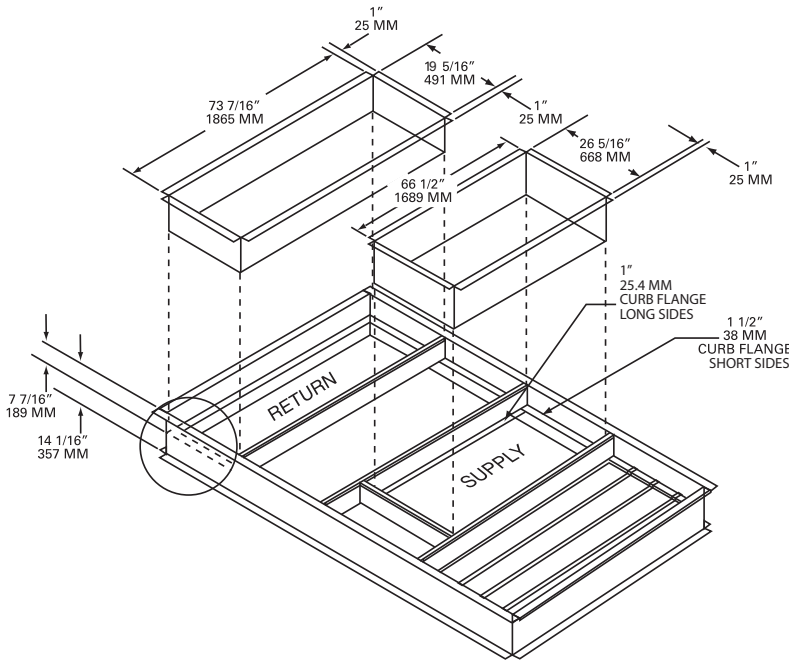

Figure 7. Downflow duct connections — field fabricated 15 to 22 tons standard efficiency



Notes:

- Duct flanges mount 7-7/16" down inside the curb on the 1-1/2" curb flanges.
- Roofcurb is intended for downflow use only.

Dimensional Data

Figure 8. Downflow unit clearance — 15 to 22 tons standard efficiency

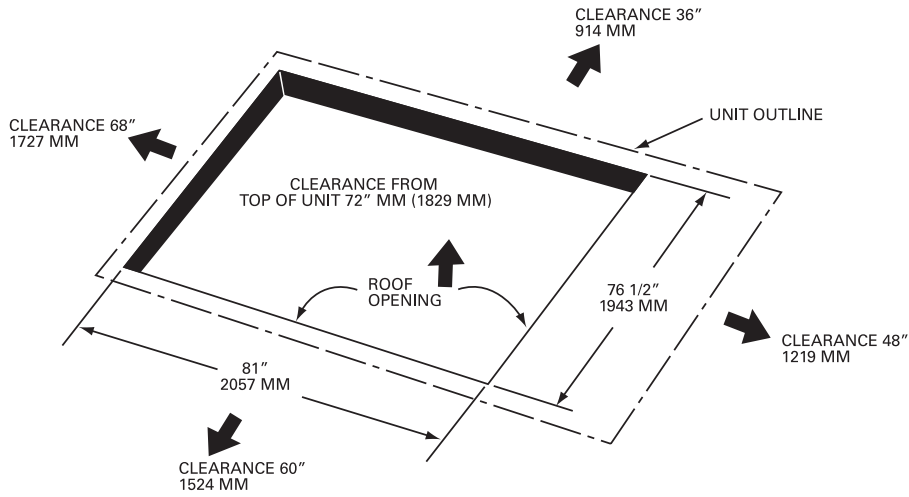
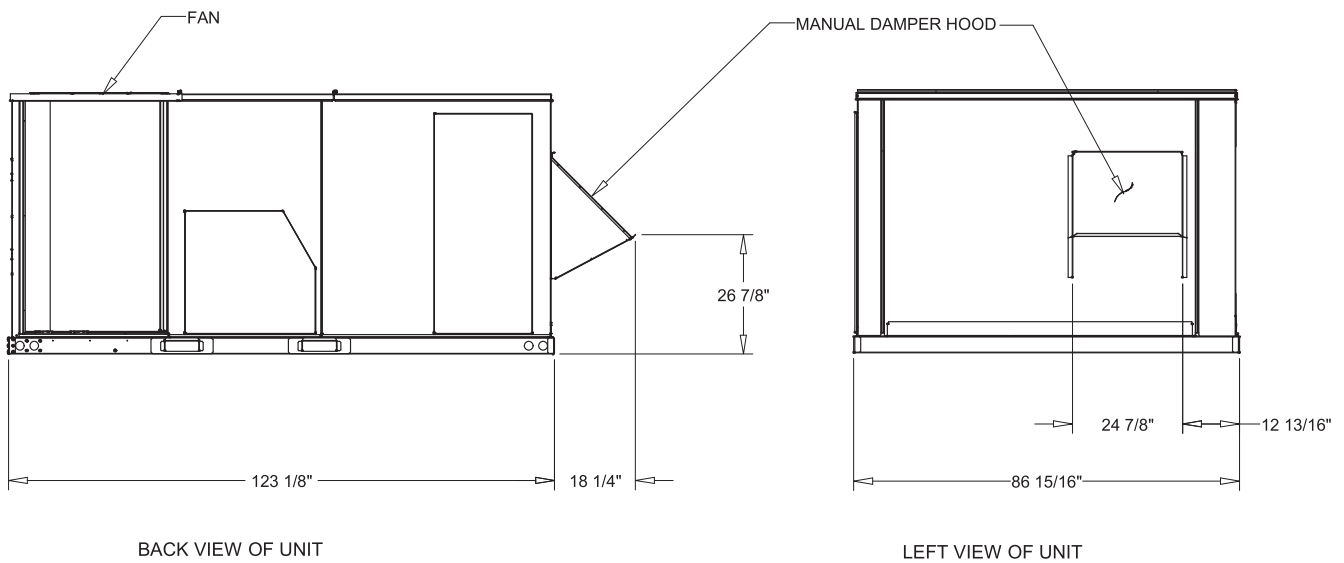

Figure 9. Manual damper — 15 to 22 tons standard efficiency



NOTE:
1. VERIFY WEIGHT, CONNECTION, AND ALL DIMENSION WITH INSTALLER DOCUMENTS BEFORE INSTALLATION

Unit Weights

Table 1. Maximum unit and corner weights (lb) and center of gravity dimensions (in.)

Tons	Unit Model No.	Weights (lb) ^{(a), (b)}		Corner Weights ^(c)				Center of Gravity (in.)	
		Shipping	Net	A	B	C	D	Length	Width
15	EAC180AD	2077	1758	581	418	358	400	55"	38"
17½	EAC210AD	2163	1844	632	438	357	416	54"	37"
20	EAC240AD	2208	1888	664	457	345	422	53"	35"
22	EAC270AD	2208	1888	664	457	345	422	53"	35"

(a) Weights are approximate. Horizontal and downflow unit and corner weights may vary slightly.

(b) Weights do not include additional factory or field installed options/accessories.

(c) Corner weights are given for information only. 15–25 ton models must be supported continuously by a curb or equivalent frame support.

Figure 10. Corner weights

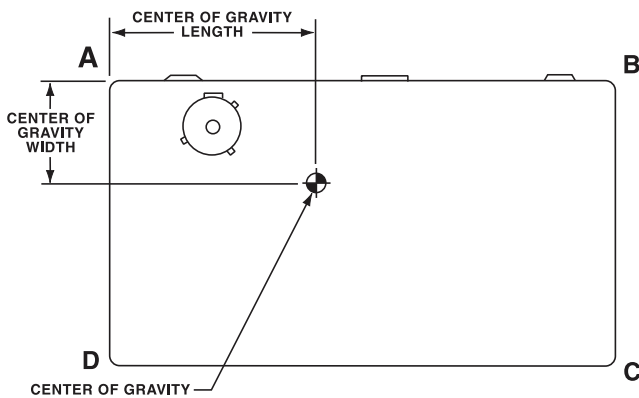

Rigging

⚠ WARNING

Heavy Objects!

Failure to follow instructions below could result in unit dropping which could result in death or serious injury, and equipment or property-only damage.

Ensure that all the lifting equipment used is properly rated for the weight of the unit being lifted. Each of the cables (chains or slings), hooks, and shackles used to lift the unit must be capable of supporting the entire weight of the unit. Lifting cables (chains or slings) may not be of the same length. Adjust as necessary for even unit lift.

⚠ WARNING

Improper Unit Lift!

Failure to properly lift unit in a LEVEL position could result in unit dropping and possibly crushing operator/ technician which could result in death or serious injury, and equipment or property-only damage.

Test lift unit approximately 24 inches (61 cm) to verify proper center of gravity lift point. To avoid dropping of unit, reposition lifting point if unit is not level.

Refer to [Figure 11, p. 13](#) and [Table 1, p. 13](#) for typical unit operating weights rigging before proceeding.

- Remove the shipping crate from around the unit. Once fork trucking is complete and unit is ready to be placed on the curb, remove all 6 fork access brackets to drop the shipping boards from underneath the unit. Do not remove the crating from the top of the unit.
- Rig the unit as shown in [Figure 11, p. 13](#). Attach adequate strength lifting slings to all four lifting brackets in the unit base rail. Do not use cables, chains, or slings except as shown.
- Install a lifting bar, as shown in [Figure 11, p. 13](#), to protect the unit and to facilitate a uniform lift. The minimum distance between the lifting hook and the top of the unit should be 7 feet.
- Test-lift the unit to ensure it is properly rigged and balanced, make any necessary rigging adjustments.
- Lift the unit and position it into place.
- Downflow units; align the base rail of the unit with the curb rail while lowering the unit onto the curb. Make sure that the gasket on the curb is not damaged while positioning the unit.

Figure 11. Rigging and center of gravity data

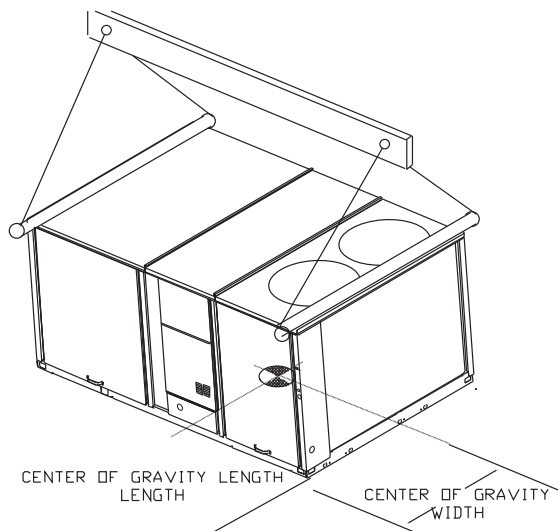

Installation

Unit Foundation

⚠ WARNING

Risk of Roof Collapsing!

Failure to ensure proper structural roof support could cause the roof to collapse, which could result in death or serious injury and property damage.

Confirm with a structural engineer that the roof structure is strong enough to support the combined weight of the roofcurb, the unit, and any accessories.

NOTICE

Water Damage!

Failure to follow instructions below could result in equipment and property damage.

Non-factory penetrations through the base of this unit are not allowed. Any penetration in the base of the unit may affect the water tight integrity of the unit and lead to water leaks into the conditioned space.

Horizontal Units

Notes:

- For complete step by step instructions on how to install a Horizontal Conversion Kit, please refer to ACC-SVN159*-EN.
- For units with optional Condensate Overflow Switch (COF), the switch will not work properly if unit is not level or slightly sloped toward switch.
- To assure proper condensate flow during operation the unit and the curb must be level.

If the unit is installed at ground level, elevate it above the snow line. Provide concrete footings at each support location with a full perimeter support structure or a slab foundation for support. Refer to [Table 1, p. 13](#) for the units operating and point loading weights when constructing a footing foundation.

If anchoring is required, anchor the unit to the slab using hold down bolts or isolators. Isolators should be installed to minimize the transmission of vibrations into the building.

For rooftop applications, if anchoring is required, anchor the unit to the roof with hold-down bolts or isolators.

Check with a roofing contractor for proper waterproofing procedures.

Ductwork

Elbows with turning vanes or splitters are recommended to minimize air noise due to turbulence and to reduce static pressure.

When attaching the ductwork to the unit, provide a water-tight flexible connector at the unit to prevent operating sounds from transmitting through the ductwork.

All outdoor ductwork between the unit and the structure should be weather proofed after installation is completed.

Note: For sound consideration, cut only the holes in the roof deck for the ductwork penetrations. Do not cut out the entire roof deck within the curb perimeter.

If a Curb Accessory Kit is not used:

- a. The ductwork can be attached directly to the factory-provided flanges around the units supply and return air openings. Be sure to use flexible duct connections at the unit.
- b. For built-up curbs supplied by others, gaskets must be installed around the curb perimeter flange and the supply and return air opening flanges.

General Unit Requirements

⚠ WARNING

Proper Field Wiring and Grounding Required!

Failure to follow code could result in death or serious injury. All field wiring **MUST** be performed by qualified personnel. Improperly installed and grounded field wiring poses **FIRE** and **ELECTROCUTION** hazards. To avoid these hazards, you **MUST** follow requirements for field wiring installation and grounding as described in **NEC** and your local/state/national electrical codes.

The checklist listed below is a summary of the steps required to successfully install a commercial unit. This checklist is intended to acquaint the installing personnel with what is required in the installation process. It does not replace the detailed instructions called out in the applicable sections of this manual.

- Check the unit for shipping damage and material shortage; file a freight claim and notify appropriate sales representative.
- Verify correct model, options and voltage from nameplate.
- Verify that the installation location of the unit will provide the required clearance for proper operation.
- Assemble and install the roof curb (if applicable). Refer to the latest edition of the curb installers guide that ships with each curb kit.
- Fabricate and install ductwork; secure ductwork to curb.
- Rigging the unit.
- Set the unit onto the curb; check for levelness.
- Ensure unit-to-curb seal is tight and without buckles or cracks.
- Install and connect a condensate drain line to the evaporator drain connection.

Main Electrical Power Requirements

- Verify that the power supply complies with the unit nameplate specifications.
- Inspect all control panel components; tighten any loose connections.
- Connect properly sized and protected power supply wiring to a field-supplied/ installed disconnect switch and to the main power terminal block (HTB1) in the unit control panel.
- Install proper grounding wires to an earth ground.

Note: All field-installed wiring must comply with NEC and applicable local codes.

Electric Heat Requirements

- Verify that the power supply complies with the electric heater specifications on the unit and heater nameplate.
- Inspect the heater junction box and control panel; tighten any loose connections.
- Check electric heat circuits for continuity.
- Low Voltage Wiring (AC and DC) Requirements
- Install the zone thermostat, with or without switching subbase.
- Connect properly sized control wiring to the proper termination points between the zone thermostat and the unit control panel.

Condensate Drain Configuration

An evaporator condensate drain connection is provided on each unit. Refer to "Dimensional Data," p. 8 for the appropriate drain location.

Note: Use 1" PVC pipe to connect to the drain pan outlet provided in the unit. This is a slip fit joint (no threads) and can be sealed using PVC Cement or other suitable adhesive.

A condensate trap must be installed at the unit due to the drain connection being on the negative pressure side of the fan.

A condensate drain line must be connected to the P-Trap. Pitch the drain lines at least 1/2-inch for every 10 feet of horizontal run to assure proper condensate flow. Do not allow the horizontal run to sag causing a possible double-trap condition which could result in condensate backup due to air lock.

Filter Installation

Each unit ships with 2-inch filters installed. The quantity of filters is determined by unit size. Access to the filters is obtained by removing the filter access panel.

Refer to the unit Service Facts (shipped with each unit) for filter requirements.

Note: Do not operate the unit without filters.

Field Installed Power Wiring

An overall dimensional layout for the standard field installed wiring entrance into the unit is illustrated in "Dimensional Data," p. 8. To insure that the units supply power wiring is properly sized and installed, follow the guidelines outlined below.

Note: All field installed wiring must conform to NEC guidelines as well as state and Local codes.

Verify that the power supply available is compatible with the units nameplate ratings. The available supply power must be within 10 percent of the rated voltage stamped on the nameplate. Use only copper conductors to connect the power supply to the unit.

NOTICE

Use Copper Conductors Only!

Failure to use copper conductors could result in equipment damage as the equipment was not designed or qualified to accept other types of conductors.

Note: If the unit is not equipped with an optional factory installed nonfused disconnect switch or circuit breaker, a field supplied disconnect switch must be installed at or near the unit in accordance with the National Electrical Code (NEC latest edition).

Main Unit Power

⚠ WARNING

Proper Field Wiring and Grounding Required!

Failure to follow code could result in death or serious injury. All field wiring MUST be performed by qualified personnel. Improperly installed and grounded field wiring poses FIRE and ELECTROCUTION hazards. To avoid these hazards, you MUST follow requirements for field wiring installation and grounding as described in NEC and your local/state/national electrical codes.

Standard Wiring

The electrical service must be protected from over current and short circuit conditions in accordance with NEC requirements.

Protection devices must be sized according to the electrical data on the nameplate.

- If the unit is not equipped with an optional factory installed nonfused disconnect switch, a field supplied disconnect switch must be installed at or near the unit in accordance with the National Electrical Code (NEC latest edition).
- Location of the applicable electrical service entrance is illustrated in "Dimensional Data," p. 8. Complete the units power wiring connections onto either; the main terminal block HTB1 inside the unit control panel, the factory mounted nonfused disconnect switch (UCD), or the electric heat terminal block. Refer to the customer

Installation

connection diagram that shipped with the unit for specific termination points.

- Provide proper grounding for the unit in accordance with local and national codes.

Control Power Transformer

The 24-volt control power transformers are to be used only with the accessories called out in this manual. Transformers rated greater than 50 Vac are equipped with internal circuit breakers. If a circuit breaker trips, turn **Off** all power to the unit before attempting to reset it.

The transformer is located in the control panel. The circuit breaker is located on the left side of the transformer and can be reset by pressing in on the black reset button.

Controls using 24 Vac

Before installing any connecting wiring, refer to “Dimensional Data,” p. 8 for the electrical access locations provided on the unit and Table 2, p. 16 for AC conductor sizing guidelines.

NOTICE

Use Copper Conductors Only!

Failure to use copper conductors could result in equipment damage as the equipment was not designed or qualified to accept other types of conductors.

1. Use copper conductors unless otherwise specified.
2. Ensure that the AC control wiring between the controls and the units termination point does not exceed three (3) ohms/ conductor for the length of the run.

Note: Resistance in excess of 3 ohms per conductor could cause component failure due to insufficient AC voltage supply.

3. Be sure to check all loads and conductors for grounds, shorts, and mis-wiring.
4. Do not run the AC low voltage wiring in the same conduit with the high voltage power wiring.
5. Route low voltage wiring per illustrations on the next page.

Table 2. Electromechanical thermostat 24 Vac conductors

Distance from Unit to Control	Recommended Wire Size
000–460 feet	18 gauge
000–140 m	0.75 mm ²
461–732 feet	16 gauge

Figure 12. Conventional thermostat field wiring diagram

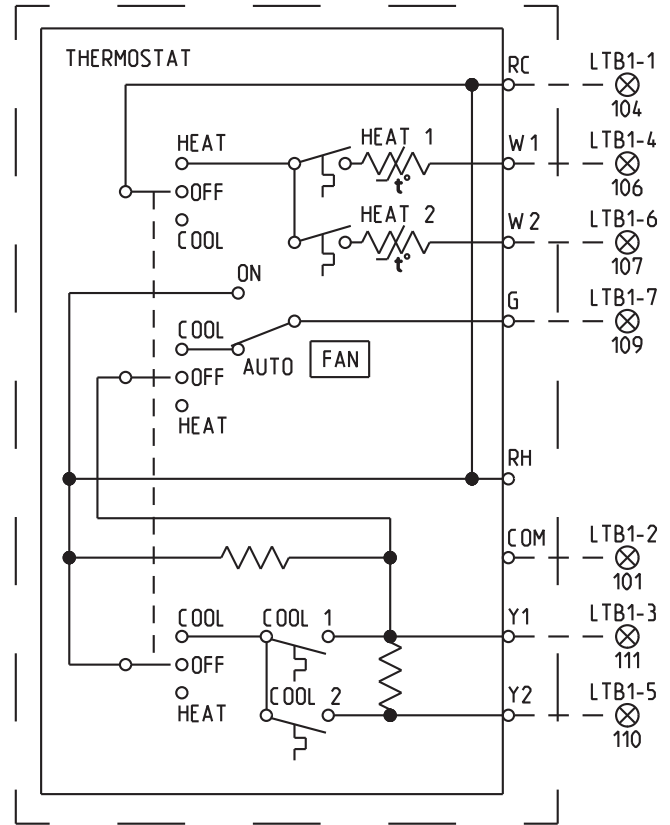

Voltage Imbalance

Three phase electrical power to the unit must meet stringent requirements for the unit to operate properly. Measure each leg (phase-to-phase) of the power supply.

Each reading must fall within the utilization range stamped on the unit nameplate. If any of the readings do not fall within the proper tolerances, notify the power company to correct this situation before operating the unit.

Excessive three phase voltage imbalance between phases will cause motors to overheat and eventually fail.

The maximum allowable voltage imbalance is 2 percent. Measure and record the voltage between phases 1, 2, and 3 and calculate the amount of imbalance as follows:

% Voltage Imbalance =

$$\frac{100 \times AV - VD}{AV} \text{ where;}$$

AV (Average Voltage) =

$$\frac{\text{Volt 1} + \text{Volt 2} + \text{Volt 3}}{3}$$

- V1, V2, V3 = Line Voltage Readings
- VD = Line Voltage reading that deviates the farthest from the average voltage.

Example: If the voltage readings of the supply power measured 221, 230, and 227, the average volts would be:

$$\frac{221 + 230 + 227}{3} = 226 \text{ Avg.}$$

- VD (reading farthest from average) = 221
- The percentage of Imbalance equals:

$$\frac{100 \times 226 - 221}{226} = 2.2\%$$

The 2.2 percent imbalance in this example exceeds the maximum allowable imbalance of 2.0 percent. This much imbalance between phases can equal as much as a 20 percent current imbalance with a resulting increase in motor winding temperatures that will decrease motor life.

If the voltage imbalance is over 2 percent, notify the proper agencies to correct the voltage problem before operating this equipment.

Electrical Phasing (Three Phase Motors)

The compressor motor(s) and the supply fan motor are internally connected for the proper rotation when the incoming power supply is phased as A, B, C.

Proper electrical supply phasing can be quickly determined and corrected before starting the unit by using an instrument such as an Associated Research Model 45 Phase Sequence Indicator and following the steps below:

⚠ WARNING

Hazardous Voltage!

Failure to disconnect power before servicing could result in death or serious injury.

Disconnect all electric power, including remote disconnects before servicing. Follow proper lockout/tagout procedures to ensure the power can not be inadvertently energized. Verify that no power is present with a voltmeter.

- Turn the field supplied disconnect switch that provides power to the main power terminal block or to the Line side of the optional factory mounted disconnect switch to the **Off** position.
- Connect the phase sequence indicator leads to the terminal block or to the Line side of the optional factory mounted disconnect switch as follows;
 - Black (phase A) to L1
 - Red (phase B) to L2
 - Yellow (phase C) to L3
- Close the field supplied main power disconnect switch or circuit protector switch that provides the supply power to the unit.

⚠ WARNING

Live Electrical Components!

Failure to follow all electrical safety precautions when exposed to live electrical components could result in death or serious injury.

When it is necessary to work with live electrical components, have a qualified licensed electrician or other individual who has been properly trained in handling live electrical components perform these tasks.

- Observe the ABC and CBA phase indicator lights on the face of the sequencer. The ABC indicator light will glow if the phase is ABC. If the CBA indicator light glows, open the disconnect switch or circuit protection switch and reverse any two power wires.
- Restore the main electrical power and recheck the phasing. If the phasing is correct, open the disconnect switch or circuit protection switch and remove the phase sequence indicator.

Compressor Crankcase Heaters

NOTICE

Compressors Failure!

Failure to follow instruction below could result in compressor failure.

Unit must be powered and crankcase heaters energized at least 8 hours BEFORE compressors are started.

Each compressor can be equipped with a crankcase heater. The proper operation of the crankcase heater is important to maintain an elevated compressor oil temperature during the Off cycle to reduce oil foaming during compressor starts. Oil foaming occurs when refrigerant condenses in the compressor and mixes with the oil. In lower ambient conditions, refrigerant migration to the compressor could increase.

When the compressor starts, the sudden reduction in crankcase pressure causes the liquid refrigerant to boil rapidly causing the oil to foam. This condition could damage compressor bearings due to reduced lubrication and could cause compressor mechanical failures.

Before starting the unit in the **Cooling** mode, set the system switch to the **Off** position and turn the main power disconnect to the **On** position and allow the crankcase heater to operate a minimum of 8 hours.

Before closing the main power disconnect switch, insure that the **System** selection switch is in the **Off** position and the **Fan** selection switch is in the **Auto** position.

Close the main power disconnect switch and the unit mounted disconnect switch, if applicable.

Installation

Checklist

Use the following checklist in conjunction with the general checklist ("[General Unit Requirements](#)," p. 14) to ensure that the unit is properly installed and ready for operation.

WARNING

Hazardous Voltage!

Failure to disconnect power before servicing could result in death or serious injury.

Disconnect all electric power, including remote disconnects before servicing. Follow proper lockout/tagout procedures to ensure the power can not be inadvertently energized. Verify that no power is present with a voltmeter.

- Check all electrical connections for tightness and point of termination accuracy.
- Verify that the condenser airflow is unobstructed.
- Verify that the condenser fan and indoor blower turn freely without rubbing and are properly tightened on the shafts.
- Check the supply fan belts for proper tension and the fan bearings for sufficient lubrication. If the belts require adjustment, or if the bearings need lubricating, refer to the maintenance section of this manual for instructions.
- Verify that a condensate trap is installed and the piping is properly sized and pitched.
- Verify that the correct size and number of filters are in place.
- Inspect the interior of the unit for tools and debris and install all panels in preparation for starting the unit.

Pre-Start

Verifying Proper Air Flow (Units with Belt Drive Indoor Fan)

Much of the systems performance and reliability is closely associated with, and dependent upon having the proper airflow supplied both to the space that is being conditioned and across the evaporator coil.

The indoor fan speed is changed by opening or closing the adjustable motor sheave.

Before starting the SERVICE TEST, set the minimum position setpoint for the economizer to 0% using the setpoint potentiometer located on the Economizer Control (ECA), if applicable.

Electromechanical Controls Test Procedure

See unit schematic for correct wire numbers.

Fan Test and Minimum Ventilation: Connect red thermostat wire (R) to black thermostat wire (G).

Cool 1: Connect red thermostat wire (R) to yellow thermostat wire (Y1).

Cool 2: Connect red thermostat wire (R) to yellow thermostat wire (Y2).

Heat 1: Connect red thermostat wire (R) to brown thermostat wire (W1).

Heat 2: Connect red thermostat wire (R) to brown thermostat wire (W2).

Start-Up

Sequence of Operation

These units are offered with electromechanical controls.

Note: *The Condensate Overflow Switch (COF) (optional) will shut the unit down if the float is raised and the switch is closed.*

Electromechanical Controls

Electromechanical Control Cooling without an Economizer

When the thermostat switch is set to the **Cool** position and the zone temperature rises above the cooling setpoint, the thermostat Y contacts close. The compressor contactor (CC1) coil is energized provided the low pressure control (LPC1), high pressure control (HPC1) and discharge line thermostat (DLT 1) are closed. When the (CC1) contacts close, compressor (CPR1) and both outdoor fan motors (ODM1 and ODM2) start. If the first stage of cooling cannot satisfy the cooling requirement, the thermostat closes Y2. The compressor contactor (CC2) coil is energized provided the low pressure control (LPC2), high pressure control (HPC2) and discharge line thermostat (DLT 2) are closed.

When the (CC2) contacts close, compressor (CPR2) starts.

Electromechanical Evaporator Fan Operation

When the thermostat fan selection switch is set to the **Auto** position, the thermostat energizes the indoor fan relay coil (F) to start the indoor fan motor (IDM). The fan relay (F) de-energizes after the cooling requirement has been satisfied. When the heating cycle is terminated, the indoor fan relay (F) coil is de-energized with heater contactors.

When the thermostat fan selection switch is set to the **On** position, the thermostat keeps the indoor fan relay coil (F) energized for continuous fan motor operation.

Electromechanical Control Heating Operation (Units with Electric Heat)

When the system switch is set to the **Heat** position and the zone temperature falls below the heating setpoint, the thermostat closes W1 contacts the first stage electric heat contactor (AH or AH and CH) is energized. If the first stage of electric heat cannot satisfy the heating requirement, the thermostat closes W2.

When the W2 contacts close, the second stage electric heat contactor (BH or BH and DH) is energized, if applicable. The thermostat cycles both the first and second stages of heat **On** and **Off** as required to maintain the zone temperature setpoint.

Drain Pan Condensate Overflow Switch (Optional)

The Condensate Overflow Switch (COF) is utilized to prevent water overflow from the drain pan. The float switch is installed on the corner lip of the drain pan. When the condensate level

reaches the trip point, the COF relay energizes and opens the 24 Vac control circuit which disables the unit. Once the 24 Vac control circuit is opened, a delay timer will prevent unit start-up for three minutes.

Low Ambient Operation (Optional)

During low ambient operation, outside air temperature below 50°F, the Low Ambient Controller will cycle the outdoor fan motor **Off** and **On** based on discharge pressure. The indoor fan motor (IDM) will continue to operate and the outdoor fan will return to normal operation once the ambient temperature is above 50°F.

10 Horsepower Motor Overload

10HP indoor fan motors are not internally protected. For proper protection, ensure the adjustable dial on the front of the overload (located in the control box) is set to the nameplate FLA value of the indoor motor.

Compressor Start-Up

1. Attach a set of service gauges onto the suction and discharge gauge ports for each circuit. Refer to the refrigerant circuit illustration in the Service Facts.

Using the Service Test Guide, perform the proper test mode connections.

Scroll Compressors

- a. Once each compressor has started, verify that the rotation is correct. If wired correctly the suction pressure should drop and the discharge pressure should rise. If a scroll compressor is rotating backwards, it will not pump and a loud rattling sound can be observed.
- b. If the electrical phasing is correct, before condemning a compressor, interchange any two leads (at the compressor Terminal block) to check the internal phasing. Refer to the following illustration for the compressor terminal/phase identification. Do not allow the compressor to operate backwards for more than 5 seconds. Operation for a period of time longer than this will result in compressor damage. Copeland (Alliance) will experience failure also. If the compressor runs backward for an extended period, the motor winding can overheat and cause the motor winding thermostat to open.

Figure 13. Compressor terminal box

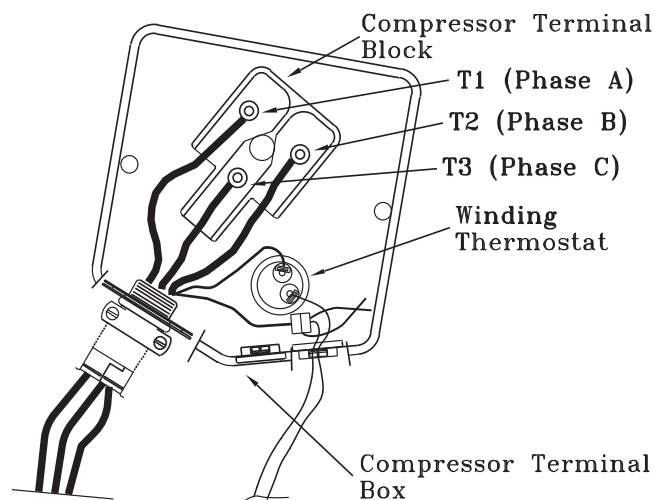

Note: The Copeland SSA scroll compressors for R-410A units use Trane OIL00094. The correct Oil for Trane CSHD is Trane OIL00079 or OIL00080. Compressor types are listed in Table 3, p. 21. The appropriate oil charge is listed in Table 4, p. 21.

Table 3. Compressor types

Tonnage	C1	C2
EA*180	SSA091	SSA091
EA*210	CSHD142	SSA076
EA*240	CSHD161	CSHD125
EA*270	CSHD161	CSHD125

Table 4. POE Oil recharge amount (fl. oz.)

Model	C1 25mm	C2 25mm
EA*180	56	56
EA*210	56	56
EA*240	112	56
EA*270	112	56

2. After the compressor and condenser fan have started and operated for approximately 30 minutes, observe the operating pressures. Compare the operating pressures to the operating pressure curve in the Service Facts.
3. Check system subcooling. Follow the instruction listed on the subcooling charging curve in the Service Facts.
4. Repeat Step 1 through Step 3 for each refrigerant circuit.
5. To stop the SERVICE TEST, turn the main power disconnect switch to the **Off** position or proceed to the next component start-up procedure. Remove electro mechanical test mode connections (if applicable).

Heating Start-Up

1. Clamp an amp meter around one of 1st stage heater power wires at the heater contactor.
2. Verify that the heater stage is operating properly.
3. Clamp an amp meter around one of 2nd stage heater power wires at the heater contactor (if applicable).
4. Verify that the heater stage is operating properly.
5. To stop the SERVICE TEST, turn the main power disconnect switch to the **Off** position or proceed to the next component start-up procedure. Remove electro mechanical test mode connections.

Final System Set Up

After completing all of the pre-start and start-up procedures outlined in the previous sections (i.e., operating the unit in each of its modes through all available stages of cooling and heating), perform these final checks before leaving the unit:

- Program the Night Setback (NSB) panel (if applicable) for proper unoccupied operation. Refer to the programming instructions for the specific panel.
- Verify that the Remote panel **System** selection switch, **Fan** selection switch, and **Zone Temperature** settings for automatic operation are correct.
- Inspect the unit for misplaced tools, hardware, and debris.
- Verify that all exterior panels including the control panel doors and condenser grilles are secured in place.
- Close the main disconnect switch or circuit protector switch that provides the supply power to the units terminal block or the unit mounted disconnect switch.

Maintenance

Make sure all personnel are standing clear of the unit before proceeding. The system components will start when the power is applied.

Fan Belt Adjustment — Belt Drive Units

⚠ WARNING

Rotating Components!

Failure to disconnect power before servicing could result in rotating components cutting and slashing technician which could result in death or serious injury. Disconnect all electric power, including remote disconnects before servicing. Follow proper lockout/tagout procedures to ensure the power can not be inadvertently energized.

The fan belts must be inspected periodically to assure proper unit operation.

Replacement is necessary if the belts appear frayed or worn. Units with dual belts require a matched set of belts to ensure equal belt length.

When removing or installing the new belts, do not stretch them over the sheaves. Loosen the belts using the belt tension adjustment bolts on the motor mounting base.

Once the new belts are installed, using a Browning or Gates tension gauge (or equivalent) illustrated in [Figure 14, p. 22](#); adjust the belt tension as follows;

1. To determine the appropriate belt deflection;
 - a. Measure the center-to-center shaft distance (in inches) between the fan and motor sheaves.
 - b. Divide the distance measured in [Step 1a](#) by 64; the resulting value represents the amount of belt deflection that corresponds to the proper belt tension.
2. Set the large O-ring on the belt tension gauge at the deflection value determined in [Step 1b](#).
3. Set the small O-ring at zero on the force scale of the gauge plunger.
4. Place the large end of the gauge at the center of the belt span; then depress the gauge plunger until the large O-ring is even with the top of the next belt or even with a straightedge placed across the fan and motor sheaves. Refer to [Table 5, p. 22](#).
5. Remove the belt tension gauge. The small O-ring now indicates a number other than zero on the plunger's force scale. This number represents the force (in pounds) required to give the needed deflection.
6. Compare the force scale reading ([Step 5](#)) with the appropriate force value listed in [Table 5, p. 22](#). If the force reading is outside the range, readjust the belt tension.

Note: Actual belt deflection force must not exceed the maximum force value shown in [Table 5, p. 22](#).

7. Recheck the belt tension at least twice during the first 2 to 3 days of operation. Belt tension may decrease until the new belts are run in.

Figure 14. Belt tension gauge

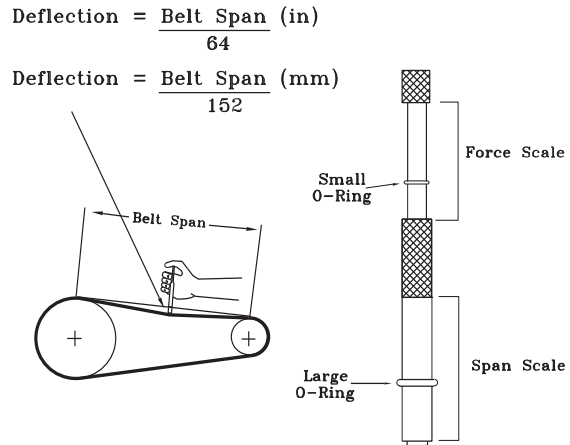

Table 5. Belt tension measurement and deflection ranges

Belts Cross Section	Small P.D Range (in.)	Deflection Force (lb)					
		Super Gripbelts (in.)		Gripnotch (in.)		Steel Cable Gripbelts (in.)	
		Min.	Max.	Min.	Max.	Min.	Max.
A	3.0–3.6	3	4 1/2	3 7/8	5 1/2	3 1/4	4
	3.8–4.8	3 1/2	5	4 1/2	6 1/4	3 3/4	4 3/4
	5.0–7.0	4	5 1/2	5	6 7/8	4 1/4	5 1/4
B	3.4–4.2	4	5 1/2	5 3/4	8	4 1/2	5 1/2
	4.4–5.6	5 1/8	7 1/8	6 1/2	9 1/8	5 3/4	7 1/4
	5.8–8.8	6 3/8	8 3/4	7 3/8	10 1/8	7	8 3/4

Belts Cross Section	Small P.D Range (mm)	Deflection Force (kg)					
		Super Gripbelts (mm)		Gripnotch (mm)		Steel Cable Gripbelts (mm)	
		Min.	Max.	Min.	Max.	Min.	Max.
A	13.3–16.0	13.3	20.0	17.2	24.5	14.5	17.8
	16.9–21.4	15.6	22.2	20.0	27.8	16.7	21.1
	22.0–31.1	17.8	24.5	22.2	30.6	18.9	23.4
B	15.1–18.7	17.8	24.5	25.6	35.6	20.0	24.5
	19.6–24.9	22.8	31.7	28.9	40.6	25.6	32.3
	25.8–39.1	28.4	38.9	32.8	45.0	31.1	38.9

Monthly Maintenance

Before completing the following checks, turn the unit **OFF** and lock the main power disconnect switch open.

⚠ WARNING

Hazardous Voltage!

Failure to disconnect power before servicing could result in death or serious injury.

Disconnect all electric power, including remote disconnects before servicing. Follow proper lockout/tagout procedures to ensure the power can not be inadvertently energized. Verify that no power is present with a voltmeter.

Filters

Inspect the return air filters. Clean or replace them if necessary. Refer to the unit Service Facts for filter information.

Condensate Overflow Switch

During maintenance, the switch float (black ring) must be checked to ensure free movement up and down.

Cooling Season

- Check the units drain pans and condensate piping to ensure that there are no blockages.
- Inspect the evaporator and condenser coils for dirt, bent fins, etc. If the coils appear dirty, clean them according to the instructions described in [“Condenser Coil Cleaning,” p. 23.](#)
- Manually rotate the condenser fan(s) to ensure free movement and check motor bearings for wear. Verify that all of the fan mounting hardware is tight.
- Inspect the F/A-R/A damper hinges and pins to ensure that all moving parts are securely mounted. Keep the blades clean as necessary.

NOTICE

Equipment Damage!

Forcibly turning the motor shaft can damage the gear train and motor beyond repair. Never turn the motor shaft by hand or with a wrench.

- Verify that all damper linkages move freely; lubricate with white grease, if necessary.
- Check supply fan motor bearings; repair or replace the motor as necessary.
- Check the fan shaft bearings for wear. Replace the bearings as necessary.
- Check the supply fan belt. If the belt is frayed or worn, replace it. Refer to [“Fan Belt Adjustment — Belt Drive Units,” p. 22](#) for belt replacement and adjustments.
- Verify that all wire terminal connections are tight.

- Remove any corrosion present on the exterior surfaces of the unit and repaint these areas.
- Generally inspect the unit for unusual conditions (e.g., loose access panels, leaking piping connections, etc.).
- Make sure that all retaining screws are reinstalled in the unit access panels once these checks are complete.
- With the unit running, check and record the: ambient temperature; compressor suction and discharge pressures (each circuit); superheat (each circuit); Record this data on an operators maintenance log like the one shown in [Table 6, p. 24.](#) If the operating pressures indicate a refrigerant shortage, measure the system superheat. For guidelines, refer to [“Compressor Start-Up,” p. 20.](#)

Note: *Do NOT release refrigerant to the atmosphere! If adding or removing refrigerant is required, the service technician must comply with all federal, state and local laws.*

Heating Season

- Inspect the units air filters. If necessary, clean or replace them.
- Check supply fan motor bearings; repair or replace the motor as necessary.
- Inspect both the main unit control panel and heat section control box for loose electrical components and terminal connections, as well as damaged wire insulation. Make any necessary repairs.
- Verify that the electric heat system operates properly.

Condenser Coil Cleaning

Regular coil maintenance, including annual cleaning, enhances the units operating efficiency by minimizing: compressor head pressure and amperage draw; evaporator water carryover; fan brake horsepower, due to increase static pressure losses; airflow reduction.

At least once each year, or more often if the unit is located in a dirty environment, clean the condenser coils using the instructions outlined below. Be sure to follow these instructions as closely as possible to avoid damaging the coils.

Microchannel (MCHE) Coils

NOTICE

Coil Damage!

Failure to follow instructions below could result in coil damage.

DO NOT use any detergents with microchannel condenser coils. Use pressurized water or air ONLY, with pressure no greater than 600psi.

For additional information regarding the proper microchannel coil cleaning procedure, refer to RT-SVB83*-EN.

Maintenance

Due to the soft material and thin walls of the MCHE coils, the traditional field maintenance method recommended for Round Tube Plate Fin (RTPF) coils does not apply to microchannel coils.

Moreover, chemical cleaners are a risk factor to MCHE due to the material of the coil. The manufacturer does not recommend the use of chemical cleaners to clean microchannel coils. Using chemical cleaners could lead to warranty claims being further evaluated for validity and failure analysis.

The recommended cleaning method for microchannel condenser coils is pressurized water or air with a non-pinpoint nozzle and an ECU of at least 180 with pressure no greater than 600 psi. To minimize the risk of coil damage, approach the cleaning of the coil with the pressure washer aimed perpendicular to the face of the coil during cleaning. Optimum clearance between the sprayer nozzle and the microchannel coil is 1”–3”.

Final Process

For future reference, you may find it helpful to record the unit data requested below in the blanks provided.

(1) Complete Unit Model Number:

(2) Unit Serial Number:

(3) Wiring Diagram Numbers (from unit control panel)

— schematic(s)

— connection(s)

Table 6. Sample maintenance log

Date	Current Ambient Temp F/C	Refrigerant Circuit #1						Refrigerant Circuit #2					
		Compr. Oil Level	Suct. Press. Psig/kPa	Disch. Press. Psig/kPa	Liquid Press. Psig/kPa	Super-heat F/C	Sub-cool F/C	Compr. Oil Level	Suct. Press. Psig/kPa	Disch. Press. Psig/kPa	Liquid Press. Psig/kPa	Super-heat F/C	Sub-cool F/C
		- ok - low						- ok - low					
		- ok - low						- ok - low					
		- ok - low						- ok - low					
		- ok - low						- ok - low					
		- ok - low						- ok - low					
		- ok - low						- ok - low					
		- ok - low						- ok - low					
		- ok - low						- ok - low					
		- ok - low						- ok - low					
		- ok - low						- ok - low					

Troubleshooting

⚠ WARNING

Hazardous Service Procedures!

Failure to follow all precautions in this manual and on the tags, stickers, and labels could result in death or serious injury.

Technicians, in order to protect themselves from potential electrical, mechanical, and chemical hazards, **MUST** follow precautions in this manual and on the tags, stickers, and labels, as well as the following instructions: Unless specified otherwise, disconnect all electrical power including remote disconnect and discharge all energy storing devices such as capacitors before servicing. Follow proper lockout/tagout procedures to ensure the power can not be inadvertently energized. When necessary to work with live electrical components, have a qualified licensed electrician or other individual who has been trained in handling live electrical components perform these tasks.

Standard Troubleshooting

Failures

Cooling Failure

1. Cooling and heating set points (slide pot) on the thermostat have failed.
2. CC1 or CC2 24 Vac control circuit has opened. Check CC1 and CC2 coils and Froststat™ status. Check the status of the LED indicator in LSD:
 - a. LED will be flashing to indicate that a Safety Input has opened while a Y call is present.
 - b. Compressor lockout is indicated by a solid (non-flashing) red LED.

To Reset LSD - Power cycle on R input.

Simultaneous Heat and Cool Failure

- Emergency Stop is activated.

Resetting Cooling and Heating Lockouts

Cooling Failures and Heating Lockouts are reset in an identical manner.

"Method 1," p. 25 explains resetting the system from the space; "Method 2," p. 25 explains resetting the system at the unit.

Note: Before resetting Cooling Failures and Heating Lockouts check the Failure Status Diagnostics by the methods previously explained. Diagnostics will be lost when the power to the unit is disconnected.

Method 1

To reset the system from the space, turn the **Mode** selection switch at the thermostat to the **Off** position. After approximately 30 seconds, turn the **Mode** selection switch to the desired mode, i.e. **Heat**, **Cool** or **Auto**.

Method 2

To reset the system at the unit, cycle the unit power by turning the disconnect switch **Off** and then **On**.

Condensate Overflow Switch

When the condensate overflow switch is closed, a drain pan overflow condition is indicated and it will shut unit operations down.

Wiring Diagrams

Note: *Wiring diagrams can be accessed via e-Library by entering the diagram number in the literature order number search field or by contacting technical support.*

Table 7. Wiring diagrams — 50Hz

Type of Airflow	Schematic Type	Voltage	Diagram Number	Description
Constant Volume	Power	380-415	2313-2204	EA*180-270, 50Hz, Cooling only / Electric Heat
	Control	208-575	2313-2207	EA*180-270, 50Hz, Cooling only / Electric Heat
	Raceway Connection	208-575	2313-2239	EA*180-270, 50Hz, Cooling only / Electric Heat
	Control Box Connection	380-415	1213-2786	EA*180-270, 50Hz, Cooling only / Electric Heat

Warranty

Central Air Conditioner

EAC, EAD (Parts Only)

Models Less than 20 Tons for Commercial Use*

This warranty is extended by Trane, to the original purchaser and to any succeeding owner of the real property to which the Air Conditioner is originally affixed, and applies to products purchased and retained for use within the U.S.A. and Canada. There is no warranty against corrosion, erosion or deterioration.

If any part of your Air Conditioner fails because of a manufacturing defect within one year from the date of the original purchase, Warrantor will furnish without charge the required replacement part.

In addition, if the sealed motor-compressor fails because of a manufacturing defect within the second through fifth year from the date of original purchase, Warrantor will furnish without charge the required replacement compressor.

Warrantors obligations and liabilities under this warranty are limited to furnishing F.O.B. Warrantor factory or warehouse replacement parts for Warrantors products covered under this warranty.

Warrantor shall not be obligated to pay for the cost of lost refrigerant.

No liability shall attach to Warrantor until products have been paid for and then liability shall be limited solely to the purchase price of the equipment under warranty shown to be defective.

THE WARRANTY AND LIABILITY SET FORTH HEREIN ARE IN LIEU OF ALL OTHER WARRANTIES AND LIABILITIES, WHETHER IN CONTRACT OR IN NEGLIGENCE, EXPRESS OR IMPLIED, IN LAW OR IN FACT, INCLUDING BUT NOT SPECIFICALLY LIMITED TO IMPLIED WARRANTIES OF MERCHANTABILITY AND FITNESS FOR PARTICULAR USE, AND IN NO EVENT SHALL WARRANTOR BE LIABLE FOR ANY INCIDENTAL OR CONSEQUENTIAL DAMAGES.

Some states do not allow limitations on how long an implied warranty lasts or do not allow the exclusion or limitation of incidental or consequential damages, so the above limitation or exclusion may not apply to you. This warranty gives you specific legal rights, and you may also have other rights which vary from state to state.

Trane
2701 Wilma Rudolph Blvd.
Clarksville, TN 37040-1008
Attention: Manager, Product Service
GW-602-4800

* This warranty is for commercial usage of said equipment and not applicable when the equipment is used for a residential application. Commercial use is any application where the end purchaser uses the product for other than personal, family or household purposes.

Models 20 Tons and Greater for Commercial Use*

The Company warrants for a period of 12 months from initial start-up or 18 months from date of shipment, whichever is less, that the Company products covered by this order (1) are free from defects in material and workmanship and (2) have the capacities and ratings set forth in the Companys catalogs and bulletins, provided that no warranty is made against corrosion, erosion or deterioration.

In addition, if the sealed motor-compressor fails because of a manufacturing defect within the second through fifth year from the date of original purchase, Warrantor will furnish without charge the required replacement compressor

The Companys obligations and liabilities under this warranty are limited to furnishing f.o.b. factory or warehouse at Company designated shipping point, freight allowed to Buyers city (or port of export for shipment outside the conterminous United States) replacement equipment (or at the option of the Company parts therefore) for all Company products not conforming to this warranty and which have been returned to the manufacturer.

The Company shall not be obligated to pay for the cost of lost refrigerant.

No liability whatsoever shall attach to the Company until said products have been paid for and then said liability shall be limited to the purchase price of the equipment shown to be defective.

The Company makes certain further warranty protection available on an optional extra-cost basis. Any further warranty must be in writing, signed by an officer of the Company.

The warranty and liability set forth herein are in lieu of all other warranties and liabilities, whether in contract or in negligence, express or implied, in law or in fact, including implied warranties of merchantability and fitness for particular use. In no event shall the Company be liable for any incidental or consequential damages.

Trane
2701 Wilma Rudolph Blvd.
Clarksville, TN 37040-1008
Attention: Manager, Product Service

** This warranty is for commercial usage of said equipment and not applicable when the equipment is used for a residential application. Commercial use is any application where the end purchaser uses the product for other than personal, family or household purposes.

Trane and American Standard create comfortable, energy efficient indoor environments for commercial and residential applications. For more information, please visit trane.com or americanstandardair.com.

Trane and American Standard have a policy of continuous product and product data improvement and reserve the right to change design and specifications without notice. We are committed to using environmentally conscious print practices.