



Installation, Operation, and Maintenance

Series R® Rotary Liquid Chillers

Water-Cooled Model RTWD

60 to 250 Tons



X3964145003

⚠ SAFETY WARNING

Only qualified personnel should install and service the equipment. The installation, starting up, and servicing of heating, ventilating, and air-conditioning equipment can be hazardous and requires specific knowledge and training. Improperly installed, adjusted or altered equipment by an unqualified person could result in death or serious injury. When working on the equipment, observe all precautions in the literature and on the tags, stickers, and labels that are attached to the equipment.

September 2024

RLC-SVX09R-EN

TRANE
TECHNOLOGIES



Introduction

Read this manual thoroughly before operating or servicing this unit.

Warnings, Cautions, and Notices

Safety advisories appear throughout this manual as required. Your personal safety and the proper operation of this machine depend upon the strict observance of these precautions.

The three types of advisories are defined as follows:



Indicates a potentially hazardous situation which, if not avoided, could result in death or serious injury.



Indicates a potentially hazardous situation which, if not avoided, could result in minor or moderate injury. It could also be used to alert against unsafe practices.



Indicates a situation that could result in equipment or property-damage only accidents.

Important Environmental Concerns

Scientific research has shown that certain man-made chemicals can affect the earth's naturally occurring stratospheric ozone layer when released to the atmosphere. In particular, several of the identified chemicals that may affect the ozone layer are refrigerants that contain Chlorine, Fluorine and Carbon (CFCs) and those containing Hydrogen, Chlorine, Fluorine and Carbon (HCFCs). Not all refrigerants containing these compounds have the same potential impact to the environment. Trane advocates the responsible handling of all refrigerants.

Important Responsible Refrigerant Practices

Trane believes that responsible refrigerant practices are important to the environment, our customers, and the air conditioning industry. All technicians who handle refrigerants must be certified according to local rules. For the USA, the Federal Clean Air Act (Section 608) sets forth the requirements for handling, reclaiming, recovering and recycling of certain refrigerants and the equipment that is used in these service procedures. In addition, some states or municipalities may have additional requirements that must also be adhered to for responsible management of refrigerants. Know the applicable laws and follow them.

⚠ WARNING

Proper Field Wiring and Grounding Required!

Failure to follow code could result in death or serious injury.

All field wiring **MUST** be performed by qualified personnel. Improperly installed and grounded field wiring poses **FIRE** and **ELECTROCUTION** hazards. To avoid these hazards, you **MUST** follow requirements for field wiring installation and grounding as described in **NEC** and your local/state/national electrical codes.

⚠ WARNING

Personal Protective Equipment (PPE) Required!

Failure to wear proper PPE for the job being undertaken could result in death or serious injury.

Technicians, in order to protect themselves from potential electrical, mechanical, and chemical hazards, **MUST** follow precautions in this manual and on the tags, stickers, and labels, as well as the instructions below:

- **Before installing/servicing this unit, technicians MUST put on all PPE required for the work being undertaken (Examples; cut resistant gloves/sleeves, butyl gloves, safety glasses, hard hat/bump cap, fall protection, electrical PPE and arc flash clothing). ALWAYS refer to appropriate Safety Data Sheets (SDS) and OSHA guidelines for proper PPE.**
- **When working with or around hazardous chemicals, ALWAYS refer to the appropriate SDS and OSHA/GHS (Global Harmonized System of Classification and Labelling of Chemicals) guidelines for information on allowable personal exposure levels, proper respiratory protection and handling instructions.**
- **If there is a risk of energized electrical contact, arc, or flash, technicians MUST put on all PPE in accordance with OSHA, NFPA 70E, or other country-specific requirements for arc flash protection, PRIOR to servicing the unit. NEVER PERFORM ANY SWITCHING, DISCONNECTING, OR VOLTAGE TESTING WITHOUT PROPER ELECTRICAL PPE AND ARC FLASH CLOTHING. ENSURE ELECTRICAL METERS AND EQUIPMENT ARE PROPERLY RATED FOR INTENDED VOLTAGE.**

⚠ WARNING**Follow EHS Policies!**

Failure to follow instructions below could result in death or serious injury.

- All Trane personnel must follow the company's Environmental, Health and Safety (EHS) policies when performing work such as hot work, electrical, fall protection, lockout/tagout, refrigerant handling, etc. Where local regulations are more stringent than these policies, those regulations supersede these policies.
- Non-Trane personnel should always follow local regulations.

⚠ WARNING**Refrigerant under High Pressure!**

Failure to follow instructions below could result in an explosion which could result in death or serious injury or equipment damage.

System contains oil and refrigerant under high pressure. Recover refrigerant to relieve pressure before opening the system. See unit nameplate for refrigerant type. Do not use non-approved refrigerants, refrigerant substitutes, or refrigerant additives.

Factory Warranty Information

Compliance with the following is required to preserve the factory warranty:

All Unit Installations

Startup MUST be performed by Trane, or an authorized agent of Trane, to VALIDATE this WARRANTY. Contractor must provide a two-week startup notification to Trane (or an agent of Trane specifically authorized to perform startup).

Additional Requirements for Units Requiring Disassembly

When a new fully assembled chiller is shipped and received from our Trane manufacturing location, and, for any reason, it requires disassembly or partial disassembly — which could include but is not limited to the evaporator, condenser, control panel, compressor/motor, or any other components originally attached to the fully assembled unit — compliance with the following is required to preserve the factory warranty:

- Trane, or an agent of Trane specifically authorized to perform startup and warranty of Trane® products, will perform or have direct onsite technical supervision of the disassembly and reassembly work.

- The installing contractor must notify Trane — or an agent of Trane specifically authorized to perform startup and warranty of Trane products — two weeks in advance of the scheduled disassembly work to coordinate the disassembly and reassembly work.
- Startup must be performed by Trane or an agent of Trane specifically authorized to perform startup and warranty of Trane products as noted above.

Trane, or an agent of Trane specifically authorized to perform startup and warranty of Trane® products, will provide qualified personnel and standard hand tools to perform the disassembly work at a location specified by the contractor. The contractor shall provide the rigging equipment such as chain falls, gantries, cranes, forklifts, etc. necessary for the disassembly and reassembly work and the required qualified personnel to operate the necessary rigging equipment.

Copyright

This document and the information in it are the property of Trane, and may not be used or reproduced in whole or in part without written permission. Trane reserves the right to revise this publication at any time, and to make changes to its content without obligation to notify any person of such revision or change.

Trademarks

All trademarks referenced in this document are the trademarks of their respective owners.

Product Safety Information

This appliance is not intended for use by persons (including children) with reduced physical, sensory or mental capabilities, or lack of experience and knowledge, unless they have been given supervision or instruction concerning use of the appliance by a person responsible for their safety. Children should be supervised to ensure that they do not play with the appliance.

Maximum altitude of use 3000 meters.

This appliance incorporates an earth connection for functional purposes only.

For installation only in locations not accessible to the general public.

Revision History

- Replaced hazard content in the Introduction section including standard Warnings, Cautions, and Notices: Proper Field Wiring and Grounding, PPE, EHS Policies, and Refrigerant Under High Pressure.
- Replaced Factory Warranty Information content.



Table of Contents

Model Number Information	6	Condenser Water Piping	43
Nameplates	6	Condenser Piping Components	43
Unit Nameplate	6	Water Regulating Valve	44
Compressor Nameplate	6	Condenser Drains and Vents	44
Model Number Coding System	6	Water Treatment	44
ASME Nameplate	6	Water Pressure Gauges	44
Model Number Descriptions	7	Water Pressure Release Valves	44
Unit Model Number	7	Refrigerant Relief Valve Venting	44
Compressor Model Number	9	High Pressure Side Relief Valve	
General Information	10	Venting (RTWD-Condenser)	45
Unit Description	10	Low Pressure Side Relief Valve Venting	
Accessory/Options Information	10	(Evaporator)	45
General Data	10	Summary of Relief Valves	46
Pre-Installation	16	Installation - Electrical	47
Inspection Checklist	16	General Recommendations	47
Unit Storage	16	Installer-Supplied Components	47
Installation Requirements and Contractor		Power Supply Wiring	47
Responsibilities	16	Control Power Supply	48
Unit Dimensions and Weights	18	Interconnecting Wiring	48
Unit Dimensions	18	Chilled Water Flow (Pump)	
Service Clearance	23	Interlock	48
RTWD Weights	23	Condenser Water Flow Interlock	48
Installation - Mechanical	25	Chilled Water Pump Control	48
Location Requirements	25	Alarm and Status Relay Outputs	
Noise Considerations	25	(Programmable Relays)	49
Foundation	25	Relay Assignments	50
Clearances	25	Low Voltage Wiring	50
Ventilation	25	Building Automation Systems	54
Rigging	25	BACnet® Building Automation Control	
Lifting Procedure	28	Network	54
Unit Isolation and Leveling	28	Modbus® Automation Control	
Evaporator Water Piping	32	Network	54
Reversing Waterboxes	33	LonTalk® Building Automation	
Evaporator Piping Components	34	Systems	54
Evaporator Flow Switch (Optional)	34	Operating Principles	55
Flow Proving Devices	35	Refrigeration (Cooling) Cycle	56
Pressure Drop Curves	35	Overview	56
Low Evaporator Refrigerant Cutout,		Cycle Description	56
Percent Glycol Requirements	41	Compressor	57
		Oil Management	57
		Controls	58
		Symbio™ 800	58

AdaptiView™ Display	58	Refrigerant and Oil Charge	
Tracer® TU	58	Management	66
Pre-Start	59	Heat Exchanger Maintenance	66
Start-Up and Shutdown	60	Cleaning the Condenser	66
Unit Start-Up	60	Cleaning the Evaporator	69
Temporary Shutdown and Restart	60	Lubrication System	70
Extended Unit Shutdown	60	Compressor Oil	70
Seasonal Unit Start-Up Procedure	60	Oil Sump Level Check	70
Sequence of Operation	61	Diagnostics	72
Software Operation Overview	61	General Diagnostics Information	72
Power Up Diagram	61	Starter Diagnostics	72
Power Up to Starting	62	Main Processor Diagnostics	76
Stopped to Starting	63	Communication Diagnostics	86
Normal Shutdown to Stopped	64	Wiring	92
Maintenance	65	Log and Check Sheets	93
Overview and Maintenance Checks	65	Model RTWD Chiller Installation	
Weekly Maintenance and Checks	65	Completion Check Sheet and Request for	
Monthly Maintenance and Checks	65	Trane Service	94
Annual Maintenance	65	Chiller Log Sheet	96
Scheduling Other Maintenance	65		



Model Number Information

Nameplates

Unit nameplates are applied to the exterior of the control panel. A compressor nameplate is located on each compressor. When the unit arrives, compare all nameplate data with ordering, submittal, and shipping information.

Unit Nameplate

The unit nameplate provides the following information:

- Model
- Serial number
- Electrical requirements
- Operating charges (refrigerant and oil)
- Design pressures
- Installation, operation and maintenance and service data literature
- Drawing numbers for unit wiring diagrams

Compressor Nameplate

The compressor nameplate provides the following information:

- Compressor model number
- Compressor serial number

- Compressor electrical characteristics
- Utilization range
- Recommended refrigerant

See Model Number Descriptions chapter for compressor model and serial number descriptions.

Model Number Coding System

Model numbers are composed of numbers and letters that represent features of the equipment.

Each position, or group of positions, in the model number is used to represent a feature. Unit model number digits are selected and assigned in accordance with the definitions as listed in Model Number Descriptions chapter.

ASME Nameplate

The ASME nameplate is different for the evaporators, condensers, and oil separators. The evaporator nameplate is located on the left portion of the shell. The insulation over the nameplate is intentionally left unglued, for ease in viewing the nameplate.

The condenser nameplate is on the backside of the condenser below circuit 2 compressor.



Model Number Descriptions

Unit Model Number

Digit 1, 2, 3, 4 — Chiller Model

RTWD = Water-Cooled Chiller Series R®

Digit 5, 6, 7 — Unit Nominal Tonnage

080 = 80 Nominal Tons
090 = 90 Nominal Tons
100 = 100 Nominal Tons
110 = 110 Nominal Tons
120 = 120 Nominal Tons
130 = 130 Nominal Tons
140 = 140 Nominal Tons
150 = 150 Nominal Tons
160 = 160 Nominal Tons
180 = 180 Nominal Tons
200 = 200 Nominal Tons
220 = 220 Nominal Tons
250 = 250 Nominal Tons

Digit 8 — Unit Voltage

A = 200/60/3
B = 230/60/3
D = 380/60/3
F = 460/60/3
G = 575/60/3

Digit 9 — Manufacturing Plant

2 = Pueblo, USA

Digit 10, 11 — Design Sequence

** = Factory Assigned

Digit 12 — Unit Type

1 = Standard Efficiency/Performance
2 = High Efficiency/Performance
3 = Premium Efficiency/Performance

Digit 13 — Agency Listing

0 = No Agency Listing
U = ETL Listed/Certified to CSA/Conforms to UL

Digit 14 — Pressure Vessel Code

1 = ASME Pressure Vessel Code
2 = Australian Code

Digit 15 — Unit Application

A = Std Condenser <=95°F/35°C Entering Water Temperature
B = High Temperature Condenser >95°F/35°C Entering Water Temperature
C = Non-Reversible Heat Pump

Digit 16 — Pressure Relief Valve

1 = Single Relief Valve
2 = Dual Relief Valve with 3-Way Isolation Valve

Digit 17 — Water Connection Type

A = Grooved Type — Standard
B = Grooved Evap — Flanged Condenser

Digit 18 — Evaporator Tubes

A = Internal and External Enhanced Evaporator Copper Tube

Digit 19 — Evaporator Passes

2 = 2-Pass Evaporator
3 = 3-Pass Evaporator

Digit 20 — Evaporator Water Side Pressure

A = 150 psi/10 Bar Evaporator Water Pressure

Digit 21 — Evaporator Application

1 = Standard Cooling
2 = Low Temperature
3 = Ice Making

Digit 22 — Condenser Tubes

A = Enhanced Fin-Copper
B = Internally Enhanced 90/10 CuNi Fin

Digit 23 — Condenser Water Side Pressure

1 = 150 psi/10 Bar Condenser Water Pressure

Digit 24 — Compressor Starter Type

X = Across-the-Line-Starter
Y = Wye-Delta Closed Transition Starter

Digit 25 — Incoming Power Line Connection

1 = Single Point Power Connection
2 = Dual Point Power Connection

Digit 26 — Power Line Connection Type

A = Terminal Block
D = Circuit Breaker
E = High Fault Rated Panel with Circuit Breaker

Digit 27 — Under/Over Voltage Protection

0 = No Under/Over Voltage Protection
1 = Under/Over Voltage Protection

Digit 28 — Unit Controller

2 = Symbio™ 800/TD-7

Digit 29 — Remote Interface (Digital Comm)

0 = No Remote Digital Communication
5 = Modbus Communication Interface
B = BACnet® Interface (MS/TP)
P = BACnet® Interface (IP)
L = LonTalk® Interface

Digit 30 — External Water and Demand Limit Setpoint

0 = No External Water and Demand Limit Setpoint
A = External Water and Demand Limit Setpoint 4-20 mA
B = External Water and Demand Limit Setpoint 2-10 Vdc

Digit 31 — Ice Making

0 = No Ice Making
A = Ice Making with Relay
B = Ice Making without Relay

Digit 32 — Programmable Relays

0 = No Programmable Relay
A = Programmable Relay

Digit 33 — Condenser Refrigerant Pressure Output

0 = No Condenser Refrigerant Output
1 = Condenser Water Control Output
3 = Differential Pressure Output

Digit 34 — Outdoor Air Temp Sensor

0 = No Outdoor Air Temp Sensor
A = Outdoor Air Temp Sensor — CWR Low Ambient

Digit 35 — Condenser Leaving Hot Water Temp Control

0 = No Condenser Leaving Hot Water Temp Control
1 = Condenser Leaving Hot Water Temp Control



Model Number Descriptions

Digit 36 — Power Meter

0 = No Power Meter
E = Energy Meter

Digit 37 — Motor Current Analog Output (% RLA)

0 = No Motor Current Analog Output
1 = Motor Current Analog Output

Digit 38 — A/C Fan Control

0 = No Fan Controls (RTWD)

Digit 39 — Low Ambient Fan Control

0 = No Low Ambient Fan Control Type

Digit 40 — Installation Accessories

0 = No Installation Accessories
A = Elastomeric Isolators
B = Flanged Water Connection Kit
C = Isolators and Flanged Water Connection Kit

Digit 41 — Flow Switch

0 = No Flow Switch
2 = 150 psi NEMA 1:Flow Switch x 2
4 = 150 psi NEMA 4:Flow Switch x 2
7 = Factory-Installed Proof of Flow (Evap/Cond)

Digit 42 — 2-Way Water Regulating Valve

0 = No 2-Way Water Regulating Valve
A = 3" 150 psi/88.9 mm 10.5 bar 115V
B = 3" 150 psi/88.9 mm 10.5 bar 220V
C = 4" 150 psi/114.3 mm 10.5 bar 115V
D = 4" 150 psi/114.3 mm 10.5 bar 220V

Digit 43 — Sound Reduction Package

0 = No Sound Reduction Package
A = Sound Reduction-Factory Installed

Digit 44 — Insulation

0 = No Insulation
1 = Factory Insulation – All Cold Parts
2 = Insulation for High Humidity

Digit 45 — Factory Charge

5 = Full Factory Refrigerant Charge (R-513A)
6 = Nitrogen Charge (R-513A Field Supplied)
7 = Full Factory Refrigerant Charge (R-515B)
8 = Nitrogen Charge (R-515B Field Supplied)

Digit 46 — Base Rail Forklifting

0 = No Base Rail Forklifting
B = Base Rail Forklifting

Digit 47 — Label and Literature Language

D = English

Digit 48 — Special

0 = None
F = Ship to Final Finisher

Digit 49 — Wireless Connectivity

0 = None
1 = Wi-Fi
2 = LTE Modem
3 = Air-Fi
4 = Wi-Fi and LTE Modem
5 = Wi-Fi and Air-Fi
6 = LTE Modem and Air-Fi
7 = Wi-Fi, LTE Modem, and Air-Fi

Digit 50, 51, 52, 53, 54, 55 — Special

0 = Not Used

Digit 56 — Shipping Package

2 = Shrink Wrap
3 = Skid + Shrink Wrap

Digit 59 — Performance Test

0 = No Performance Test
C = 1-Point Test with Report
D = 2-Point Test with Report
E = 3-Point Test with Report
F = 4-Point Test with Report
G = Witness 1-Point Test with Report
G = Witness 1-Point Test with Report Plus Rapid Restart
H = Witness 2-Point Test with Report
J = Witness 3-Point Test with Report
K = Witness 4-Point Test with Report
K = Witness 4-Point Test with Report Plus Rapid Restart

Digit 60 — Evaporator Fluid Type

0 = Water
1 = Calcium Chloride
2 = Ethylene Glycol
3 = Propylene Glycol
4 = Methanol

Digit 61 — Condenser Fluid Type

0 = Water
A = Calcium Chloride
B = Ethylene Glycol
C = Propylene Glycol
D = Methanol

Compressor Model Number

Digit 1, 2, 3 — Model Compressor

CHH = Positive displacement, helical rotary (twin screw) hermetic compressor

Digit 4 — Compressor Type

P = GP2
T = GP2+
W = GP2.5

Digit 5 — Economizer Port Detail

0 = No Economizer Port (zero)
A = Max Capacity
E = Optimized Unit Efficiency

Digit 6 — Compressor Frame Size

K = Frame
L = Frame
M = Frame
N = Frame

Digit 7 — Compressor Capacity

1 = GP2 Smaller Capacity (Minor)
2 = GP2 Larger Capacity (Major)
3 = GP2+ Smaller Capacity (Minor)
4 = GP2+ Larger Capacity (Major)
5 = GP2.5 Smaller Capacity
6 = GP2.5 Larger Capacity

Digit 8 — Motor Voltage

A = 200–60–3
C = 230–60–3
D = 380–60–3
H = 575–60–3
K = 460–60–3 (N6 Only)
S = Special Voltage
T = 400/460–60–3

Digit 9 — Internal Relief

K = 450 psid

Digit 10, 11 — Design Sequence

XX = Factory Assigned

Digit 12 — Capacity Limit

N = Standard capacity controls (no capacity limit)

Digit 13, 14, 15 — Motor kW Rating

043 = K1 60Hz
050 = K2 60Hz
057 = L1 60Hz
069 = L2 60Hz
077 = M1/M3 60Hz
092 = M2/M4 60Hz
112 = N1/N3/N5 60 Hz
134 = N2/N4/N6 60 Hz

Digit 16 — Volume Ratio

A = High Volume Ratio
N = Low Volume Ratio



General Information

Unit Description

The RTWD units are helical-rotary type, water-cooled, liquid chillers, designed for installation indoors. The units have 2 independent refrigerant circuits, with one compressor per circuit. The RTWD units are packaged with an evaporator and condenser

Note: Each RTWD unit is a completely assembled, hermetic package that is factory-piped, wired, leaktested, dehydrated, charged and tested for proper control operations prior to shipment. The chilled water inlet and outlet openings are covered for shipment.

The RTWD series features Trane's exclusive Adaptive Control logic with chiller controls. It monitors the control variables that govern the operation of the chiller unit. Adaptive Control logic can correct these variables, when necessary, to optimize operational efficiencies, avoid chiller shutdown, and keep producing chilled water.

Compressor unloaders are solenoid actuated. Each refrigerant circuit is provided with filter, sight glass,

electronic expansion valve, and charging valves on the RTWD.

The evaporator and condenser are manufactured in accordance with ASME standards. The evaporator is fully insulated. Both evaporator and condenser are equipped with water drain and vent connections.

Accessory/Options Information

Check all the accessories and loose parts which are shipped with the unit against the original order. Included in these items will be water vessel drain plugs, rigging diagrams, electrical diagrams, and service literature, which are placed inside the control panel and/or starter panel for shipment. Also check for optional components, such as flow switches and isolators.

General Data

Table 1. General data – RTWD, 60 Hz, standard efficiency

Size		80	90	100	110	120	130	140
Compressor								
Size Ckt1/Ckt2		K1/K1	K2/K2	K2/L1	L1/L1	L1/L2	L2/L2	L2/M1 (L2/M3)
Evaporator								
2 Pass Arrangement								
Water Conn. Size	NPS	4	4	4	4	5	5	5
	mm	100	100	100	100	125	125	125
Water Storage	gal	11.2	11.2	12.6	14.0	15.2	16.2	17.7
	l	42.2	42.2	47.6	53.0	57.4	61.5	66.8
Minimum Flow	gpm	78	78	90	102	102	111	123
	l/s	4.9	4.9	5.7	6.4	6.4	7.0	7.8
Maximum Flow	gpm	286	286	330	374	374	407	451
	l/s	18.0	18.0	20.8	23.6	23.6	25.7	28.5
3 Pass Arrangement								
Water Conn. Size	NPS	3	3	3	3	4	4	4
	mm	80	80	80	80	100	100	100
Water Storage	gal	11.2	11.2	12.6	14.0	15.2	16.2	17.7
	l	42.2	42.2	47.6	53.0	57.4	61.5	66.8
Minimum Flow	gpm	52	52	60	68	68	74	82
	l/s	3.3	3.3	3.8	4.3	4.3	4.7	5.2
Maximum Flow	gpm	191	191	220	249	249	271	301
	l/s	12.1	12.1	13.9	15.7	15.7	17.1	19.0
Condenser								

Table 1. General data – RTWD, 60 Hz, standard efficiency (continued)

Size		80	90	100	110	120	130	140
Water Conn. Size	NPS	5	5	5	5	5	5	5
	mm	125	125	125	125	125	125	125
Water Storage	gal	12.4	14.2	16.0	16.9	18.5	18.5	20.9
	l	46.8	53.6	60.4	63.8	70.1	70.1	79.2
Minimum Flow	gpm	55	66	76	82	89	89	104
	l/s	3.5	4.2	4.8	5.2	5.6	5.6	6.6
Maximum Flow	gpm	300	360	420	450	491	491	571
	l/s	18.9	22.7	26.5	28.4	31.0	31.0	36.0
General Unit								
Refrigerant Type	R-513A or R-515B							
No. of Refrig Circuits		2	2	2	2	2	2	2
Refrigerant Charge	lb	114.6/114.6	114.6/114.6	112.4/114.6	112.4/112.4	132.3/132.3	130.1/130.1	127.9/132.3
	kg	52/52	52/52	51/52	51/51	60/60	59/59	58/60
Oil Type (R-513A/R-515B)	OIL00386							
Oil Charge_R-513A	qt	7.1/7.1	7.1/7.1	7.1/10.0	10.0/10.0	10.0/10.0	10.0/10.0	10.0/10.0
	l	6.7/6.7	6.7/6.7	6.7/9.5	9.5/9.5	9.5/9.5	9.5/9.5	9.5/9.5
Oil Charge_R-515B	qt	6.7/6.7	6.7/6.7	6.7/9.5	9.5/9.5	9.5/9.5	9.5/9.5	9.5/9.5
	l	6.3/6.3	6.3/6.3	6.3/9.0	9.0/9.0	9.0/9.0	9.0/9.0	9.0/9.0

Note: Data containing information on two circuits is shown as circuit 1/circuit 2.

Table 2. General data – RTWD, 60 Hz, 80 to 130 tons, high efficiency

Size		80	90	100	110	120	130
Compressor							
Size Ckt1/Ckt2		K1/K1	K2/K2	K2/L1	L1/L1	L1/L2	L2/L2
Evaporator							
2 Pass Arrangement							
Water Conn. Size	NPS	4	4	5	5	5	5
	mm	100	100	100	125	125	125
Water Storage	gal	9.8	11.9	12.8	15.3	16.4	17.3
	l	37.0	45.2	48.3	57.9	62.3	65.4
Minimum Flow	gpm	72	91	99	111	122	129
	l/s	4.5	5.7	6.2	7.0	7.7	8.1
Maximum Flow	gpm	263	335	363	408	447	475
	l/s	16.6	21.1	22.9	25.7	28.2	30.0
3 Pass Arrangement							
Water Conn. Size	NPS	3	3	4	4	4	4
	mm	80	80	80	100	100	100
Water Storage	gal	9.8	11.9	12.8	15.3	16.4	17.3
	l	37.0	45.2	48.3	57.9	62.3	65.4
Minimum Flow	gpm	48	61	66	74	81	86
	l/s	3.0	3.8	4.2	4.7	5.1	5.4



General Information

Table 2. General data – RTWD, 60 Hz, 80 to 130 tons, high efficiency (continued)

Size		80	90	100	110	120	130
Maximum Flow	gpm	175	223	242	272	298	317
	l/s	11.0	14.1	15.3	17.2	18.8	20.0
Condenser							
Water Conn. Size Non-ASME Victaulic	NPS	5	5	5	5	5	5
	mm	125	125	125	125	125	125
Water Conn. Size ASME Flange (Class 150)	NPS	3.5	3.5	3.5	3.5	3.5	3.5
	mm	90.0	90.0	90.0	90.0	90.0	90.0
Water Storage	gal	11.9	12.7	14.9	16.6	17.2	18.0
	l	45.1	48.1	56.3	62.7	65.2	68.3
Minimum Flow	gpm	58	63	78	86	90	96
	l/s	3.7	4.0	4.9	5.4	5.7	6.1
Maximum Flow	gpm	316	346	427	472	497	527
	l/s	19.9	21.8	26.9	29.8	31.4	33.2
General Unit							
Refrigerant Type	R-513A or R-515B						
No. of Refrig Circuits		2	2	2	2	2	2
Refrigerant Charge	lb	99.2/99.2	97/97	123.5/125.7	123.5/123.5	121.3/121.3	119/119
	kg	45/45	44/44	56/57	56/56	55/55	54/54
Oil Type	OIL00386						
Oil Charge_R-513A	qt	7.1/7.1	7.1/7.1	7.1/10.0	10.0/10.0	10.0/10.0	10.0/10.0
	l	6.7/6.7	6.7/6.7	6.7/9.5	9.5/9.5	9.5/9.5	9.5/9.5
Oil Charge_R-515B	qt	6.7/6.7	6.7/6.7	6.7/9.5	9.5/9.5	9.5/9.5	9.5/9.5
	l	6.3/6.3	6.3/6.3	6.3/9.0	9.0/9.0	9.0/9.0	9.0/9.0

Note: Data containing information on two circuits is shown as circuit 1/circuit 2.

Table 3. General data – RTWD, 60 Hz, 150 to 250 tons, high efficiency

Size		150	160	180	200	220	250
Compressor							
Size Ckt1/Ckt2		L2/M1 (L2/M3)	M1/M1 (M3/M3)	M1/M2 (M3/M4)	M2/M2 (M4/M4)	M2/N1 (M4/N5)	N1/N1 (N5/N5)
Evaporator							
2 Pass Arrangement							
Water Conn. Size	NPS	5	5	5	5	6	6
	mm	125	125	125	125	150	150
Water Storage	gal	19.2	20.3	22.3	24.2	28.6	31.8
	l	72.6	77.0	84.5	91.5	108.3	120.3
Minimum Flow	gpm	140	151	169	186	210	239
	l/s	8.8	9.5	10.7	11.7	13.2	15.1
Maximum Flow	gpm	514	553	620	682	771	877
	l/s	32.4	34.9	39.1	43.0	48.6	55.3
3 Pass Arrangement							

Table 3. General data – RTWD, 60 Hz, 150 to 250 tons, high efficiency (continued)

Size		150	160	180	200	220	250
Water Conn. Size	NPS	4	4	4	4	4	4
	mm	100	100	100	100	100	100
Water Storage	gal	18.8	20.0	22.0	23.8	27.9	31.0
	l	71.2	75.6	83.2	90.1	105.5	117.5
Minimum Flow	gpm	93	101	113	124	140	159
	l/s	5.9	6.4	7.1	7.8	8.8	10.0
Maximum Flow	gpm	343	369	413	454	514	585
	l/s	21.6	23.3	26.1	28.6	32.4	36.9
Condenser							
Water Conn. Size Non-ASME Victaulic	NPS	6	6	6	6	6	6
	mm	150	150	150	150	150	150
Water Conn. Size ASME Flange (Class 150)	NPS	4	4	4	4	5	5
	mm	100.0	100.0	100.0	100.0	125.0	125.0
Water Storage	gal	21.6	22.9	24.6	26.2	31.1	39.2
	l	81.7	86.8	93.0	99.2	117.8	148.3
Minimum Flow	gpm	106	115	126	137	162	216
	l/s	6.7	7.3	7.9	8.6	10.2	13.6
Maximum Flow	gpm	582	633	693	753	894	1190
	l/s	36.7	39.9	43.7	47.5	56.4	75.1
General Unit							
Refrigerant Type	R-513A or R-515B						
No. of Refrig Circuits		2	2	2	2	2	2
Refrigerant Charge	lb	134.5/143.3	141.1/141.1	138.9/138.9	136.7/136.7	178.6/185.2	180.8/180.8
	kg	61/65	64/64	63/63	62/62	81/84	82/82
Oil Type	OIL00386						
Oil Charge_R-513A	qt	10.0/12	12.0/12.0	12.0/12.0	12.0/12.0	12.0/12.0	12.0/12.0
	l	9.5/11.4	11.4/11.4	11.4/11.4	11.4/11.4	11.4/11.4	11.4/11.4
Oil Charge_R-515B	qt	9.5/11.4	11.4/11.4	11.4/11.4	11.4/11.4	11.4/11.4	11.4/11.4
	l	9.0/10.8	10.8/10.8	10.8/10.8	10.8/10.8	10.8/10.8	10.8/10.8

Note: Data containing information on two circuits is shown as circuit 1/circuit 2.



General Information

Table 4. General data – RTWD, 60 Hz, premium efficiency

Size		150	160	180	200
Compressor					
Size Ckt1/Ckt2		L2/M1 (L2/M3)	M1/M1 (M3/M3)	M1/M2 (M3/M4)	M2/M2 (M4/M4)
Evaporator					
2 Pass Arrangement					
Water Conn. Size	NPS	6	6	6	6
	mm	150	150	150	150
Water Storage	gal	27.8	27.8	29.3	31.3
	L	105.1	105.1	110.9	118.3
Minimum Flow	gpm	174	174	186	201
	L/s	11.0	11.0	11.7	12.7
Maximum Flow	gpm	637	637	682	737
	L/s	40.2	40.2	43.0	46.5
3 Pass Arrangement					
Water Conn. Size	NPS	4	4	4	4
	mm	100	100	100	100
Water Storage	gal	27.1	27.1	28.6	30.6
	L	102.4	102.4	108.3	115.7
Minimum Flow	gpm	116	116	124	134
	L/s	7.3	7.3	7.8	8.5
Maximum Flow	gpm	425	425	454	492
	L/s	26.8	26.8	28.6	31.0
Condenser					
Water Conn. Size Non-ASME Victaulic	NPS	6	6	6	6
	mm	150	150	150	150
Water Conn. Size ASME Flange (Class 150)	NPS	4	4	4	4
	mm	100	100	100	100
Water Storage	gal	30.0	30.0	32.9	32.9
	L	113.4	113.4	124.4	124.4
Minimum Flow	gpm	137	137	153	153
	L/s	8.6	8.6	9.7	9.7
Maximum Flow	gpm	753	753	844	844
	L/s	47.5	47.5	53.2	53.2
General Unit					
Refrigerant Type	R-513A or R-515B				
No. of Refrig Circuits		2	2	2	2
Refrigerant Charge	lb	174.2/183.0	183.0/183.0	180.8/180.8	178.6/178.6
	kg	79/83	83/83	82/82	81/81
Oil Type	OIL00386				
Oil Charge_R-513A	qt	10.0/12.0	12.0/12.0	12.0/12.0	12.0/12.0
	l	9.5/11.4	11.4/11.4	11.4/11.4	11.4/11.4

Table 4. General data – RTWD, 60 Hz, premium efficiency (continued)

Size		150	160	180	200
Oil Charge_R-515B	qt	9.5/11.4	11.4/11.4	11.4/11.4	11.4/11.4
	l	9.0/10.8	10.8/10.8	10.8/10.8	10.8/10.8

Note: Data containing information on two circuits is shown as circuit 1/circuit 2.



Pre-Installation

Inspection Checklist

- Verify if the unit is correct and properly equipped when delivered. Compare the information on the unit nameplate with the ordering and submittal information. See “Unit Model Number,” p. 7 and “Compressor Model Number,” p. 9.
- Inspect all exterior components for visible damage. Report any apparent damage or material shortage to the carrier and make a **unit damage** notation on the carrier's delivery receipt. Specify the extent and type of damage found and notify the appropriate Trane Sales Office.

Important: Do not proceed with installation of a damaged unit without sales office approval.

To protect against loss due to damage incurred in transit, complete the following checklist upon receipt of the unit.

- Inspect the individual pieces of the shipment before accepting the unit. Check for obvious damage to the unit or packing material.
- Inspect the unit for concealed damage as soon as possible after delivery and before it is stored. Concealed damage must be reported within 15 days.
- Stop unpacking the shipment, if concealed damage is discovered. Do not remove damaged material from the receiving location. Take photos of the damage, if possible. The owner must provide reasonable evidence that the damage did not occur after delivery.
- Notify the carrier's terminal of the damage immediately, by phone and by mail. Request an immediate, joint

inspection of the damage with the carrier and the consignee.

- Notify the Trane sales representative and arrange for repair. Do not repair the unit, however, until damage is inspected by the carrier's representative.

Unit Storage

To store the chiller for more than one month prior to installation, observe the following precautions:

- Do not remove the protective coverings from the electrical panel.
- Store the chiller in a dry, secure area.
- At least every three months, attach a gauge and manually check the pressure in the refrigerant circuit. If the refrigerant pressure is below 78 psig with R513A and 49 psig with R515B at 70°F (or 51 psig with R513A and 30 psig with R515B at 50°F), call a qualified service organization and the appropriate Trane sales office.

Note: Pressure will be approximately 20 psig if shipped with the optional nitrogen charge.

Installation Requirements and Contractor Responsibilities

A list of the contractor responsibilities typically associated with the unit installation process is provided in the table below.

Note: Unit Start-up must be completed by a qualified Trane service technician.

Table 5. Installation requirements

Type of Requirement	Trane Supplied		Field Supplied Field Installed
	Trane Installed	Field Installed	
Foundation			Meet foundation requirements
Rigging			Safety chains Clevis connectors Lifting beam
Isolation		Isolation pads or neoprene isolators (optional)	Isolation pads or neoprene isolators (optional)

Table 5. Installation requirements (continued)

Type of Requirement	Trane Supplied		Field Supplied Field Installed
	Trane Installed	Field Installed	
Electrical	<ul style="list-style-type: none"> • Circuit breakers • Unit mounted starter 		<ul style="list-style-type: none"> • Circuit breakers • Electrical connections to unit mounted starter (optional) • Electrical connections to remote mounted starter (optional) • Wiring sizes per submittal and NEC • Terminal lugs • Ground connection(s) • BAS wiring (optional) • Control voltage wiring • Chilled water pump contactor and wiring including interlock • Condenser water pump contactor and wiring including interlock • Option relays and wiring • Energy meter • wireless modules
Water Piping	Flow switches (optional)	<ul style="list-style-type: none"> • Flow switches (may be field supplied) • Water regulating valve (optional) 	<ul style="list-style-type: none"> • Taps for thermometers and gauges • Thermometers • Strainers (as required) • Water flow pressure gauges • Isolation and balancing valves in water piping • Vents and drain on waterbox valves • Pressure relief valves (for waterboxes as required)
Relief	<ul style="list-style-type: none"> • Single relief valve • Dual relief valve (optional) 		Vent line and flexible connector and vent line from relief valve to atmosphere
Insulation	<ul style="list-style-type: none"> • Insulation • High humidity insulation (optional) 		Insulation
Water Piping Connection Components	<ul style="list-style-type: none"> • Grooved pipe • Grooved pipe to flanged connection (optional) 		
Other Materials			<ul style="list-style-type: none"> • Refrigerant (1 lb. max per machine as needed) • Dry nitrogen (20 psig max per machine as needed)

Unit Dimensions and Weights

Unit Dimensions

Figure 1. RTWD 80 to 140 tons, 60 Hz

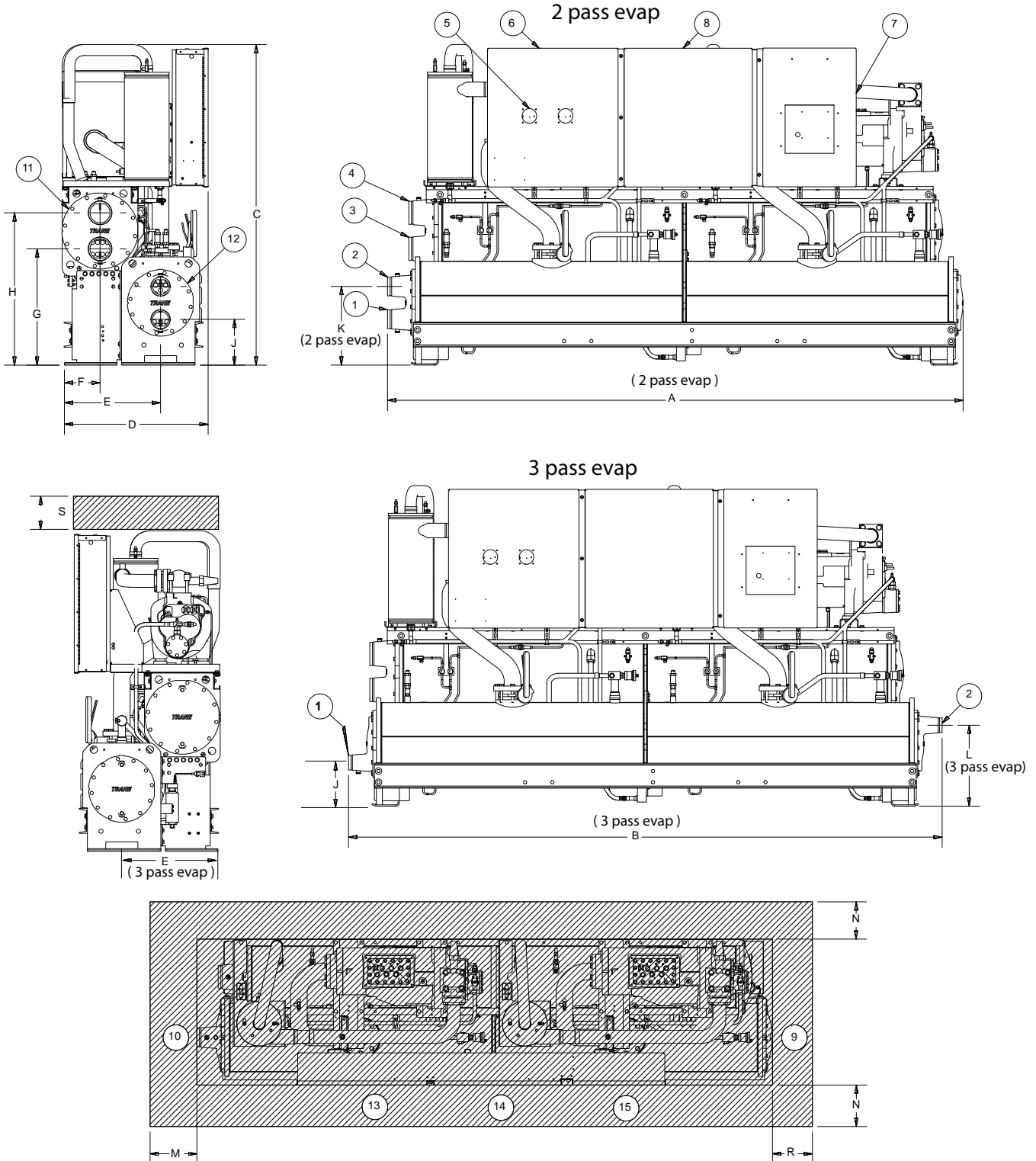

Table 6. RTWD, 80 to 140 tons, 60 Hz – in (mm)

	Standard Efficiency			RTWD - High Efficiency	
	80,90T	100,110T	120,130,140T	80,90T	100,110,120,130T
A (2 pass evap)	138.2 (3510)	138.2 (3510)	138.8 (3525)	126.4 (3210)	126.9 (3225)
B (3 pass evap)	142.6 (3621)	142.6 (3621)	142.6 (3621)	130.8 (3321)	130.7 (3320)
C	75.9 (1929)	76.9 (1955)	76.9 (1955)	76.1 (1933)	76.9 (1955)
D	34.3 (871)	34.3 (871)	34.8 (884)	35.1 (890)	35.1 (890)
E	23.6 (600)	23.6 (600)	23.6 (600)	23.6 (600)	23.6 (600)
F	9.1 (231)	9.1 (231)	9.1 (231)	9.1 (231)	9.1 (231)
G	27.9 (709)	27.9 (709)	27.9 (709)	27.9 (709)	27.9 (709)
H	36.6 (929)	36.6 (929)	36.6 (929)	36.6 (929)	36.6 (929)
J (2 pass evap)	11.0 (280)	11.0 (280)	10.6 (268)	10.8 (273)	11.8 (299)
J (3 pass evap)	10.4 (265)	10.4 (265)	10.1 (256)	10.2 (258)	11.3 (287)
K (2 pass evap)	18.9 (479)	18.9 (479)	19.2 (487)	18.6 (472)	20.4 (519)
L (3 pass evap)	19.5 (495)	19.5 (495)	19.5 (496)	19.2 (488)	19.2 (487)
M	36 (914)	36 (914)	36 (914)	36 (914)	36 (914)
N*	36 (914)*	36 (914)*	36 (914)*	36 (914)*	36 (914)*
R	127 (3226)	127 (3226)	127 (3226)	115 (2921)	115 (2921)
S	36 (914)	36 (914)	36 (914)	36 (914)	36 (914)

Reference
Notes:

1. Evaporator Water Inlet
2. Evaporator Water Outlet
3. Condenser Water Inlet
4. Condenser Water Outlet
5. Power Disconnect
6. Power Wire
7. Control Wire
8. Control Panel
9. Condenser Return Waterbox End - minimum clearance (for tube removal)
10. Condenser Supply Waterbox End - minimum clearance (for maintenance)
11. Condenser
12. Evaporator
13. Panel Power Section - door swing 31.3 inch (796.9 mm)
14. Panel Power Section - door swing 31.1 inch (790.1 mm)
15. Panel Control Section - door swing 22.4 inch (568.14 mm)
16. 42 inch (1067 mm) clearance required to other ground parts, two units with panels facing each other or other live parts require a clearance of 48 inch (1220 mm)
17. Sound attenuator may increase the footprint - submittal should be used.



Unit Dimensions and Weights

Figure 2. RTWD, 150 to 250 tons, 60 Hz

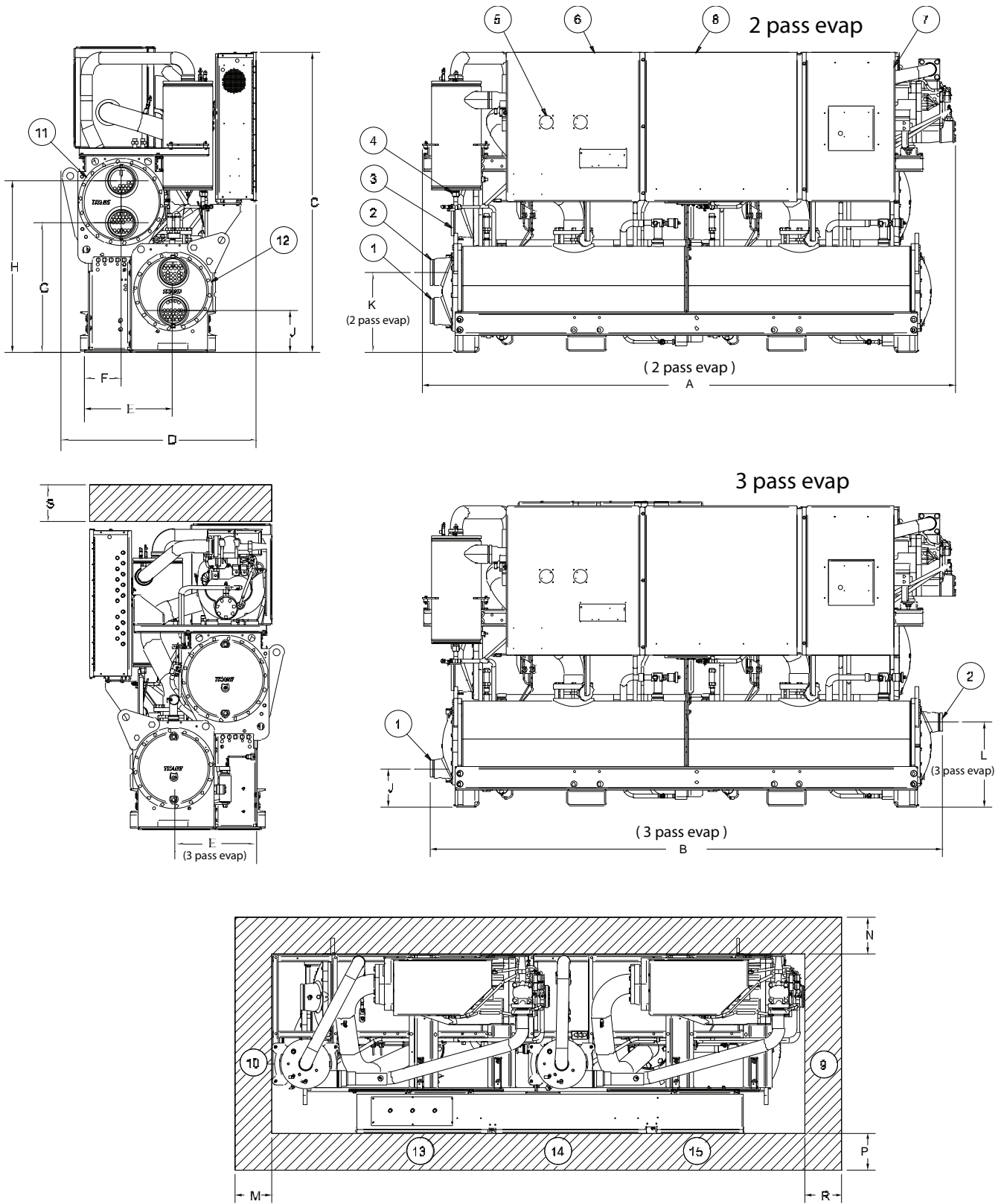

Table 7. RTWD, 150 to 250 tons, 60 Hz – in (mm)

	RTWD		
	High Efficiency		Prem Efficiency
	150-200T	220, 250T	150-200T
A (2 pass evap)	132.3 (3360)	136.1 (3456)	147.9 (3755)
B (3 pass evap)	132.8 (3371)	136.1 (3456)	150.9 (3831)
C	75.6 (1920)	76.9 (1955)	76.8 (1950)
D	47.3 (1202)	47.8 (1213)	47.3 (1202)
E	24.6 (624)	24.8 (630)	24.6 (624)
F	11.1 (282)	11.2 (295)	11.1 (282)
G	32.7 (830)	33.1 (840)	33.8 (860)
H	42.4 (1078)	43.9 (1115)	43.6 (1108)
J (2 pass evap)	10.1 (256)	10.6 (270)	10.6 (270)
J (3 pass evap)	9.5 (241)	9.7 (247)	9.7 (247)
K (2 pass evap)	19.3 (490)	20.6 (524)	20.6 (524)
L (3 pass evap)	19.9 (505)	21.6 (549)	21.6 (549)
M	36.0 (914)	36.0 (914)	36.0 (914)
N	36.0 (914)	36.0 (914)	36.0 (914)
P*	40 (1016)*	40 (1016)*	40 (1016)*
R	114.8 (2916)	114.8 (2916)	134.5 (3416)
S	36.0 (914)	36.0 (914)	36.0 (914)

Reference
Notes:

1. Evaporator Water Inlet
2. Evaporator Water Outlet
3. Condenser Water Inlet
4. Condenser Water Outlet
5. Power Disconnect
6. Power Wire
7. Control Wire
8. Control Panel
9. Condenser Return Waterbox End - minimum clearance (for tube removal)
10. Condenser Supply Waterbox End - minimum clearance (for maintenance)
11. Condenser
12. Evaporator
13. Panel Power Section - door swing 31.3 inch (796.9 mm)
14. Panel Power Section - door swing 31.1 inch (790.1 mm)
15. Panel Control Section - door swing 22.4 inch (568.14 mm)
16. Control panel clearance is 36 or 40 inch (914 or 1016 mm) depending on voltages, starter type, unit application and local code; 42 inch (1067 mm) clearance required to other grounded parts; two units with panels facing each other or other live parts require a clearance of 48 inch (1220 mm).
17. Sound attenuator may increase the footprint - submittal should be used.

Unit Dimensions and Weights

Figure 3. RTWD unit footprint

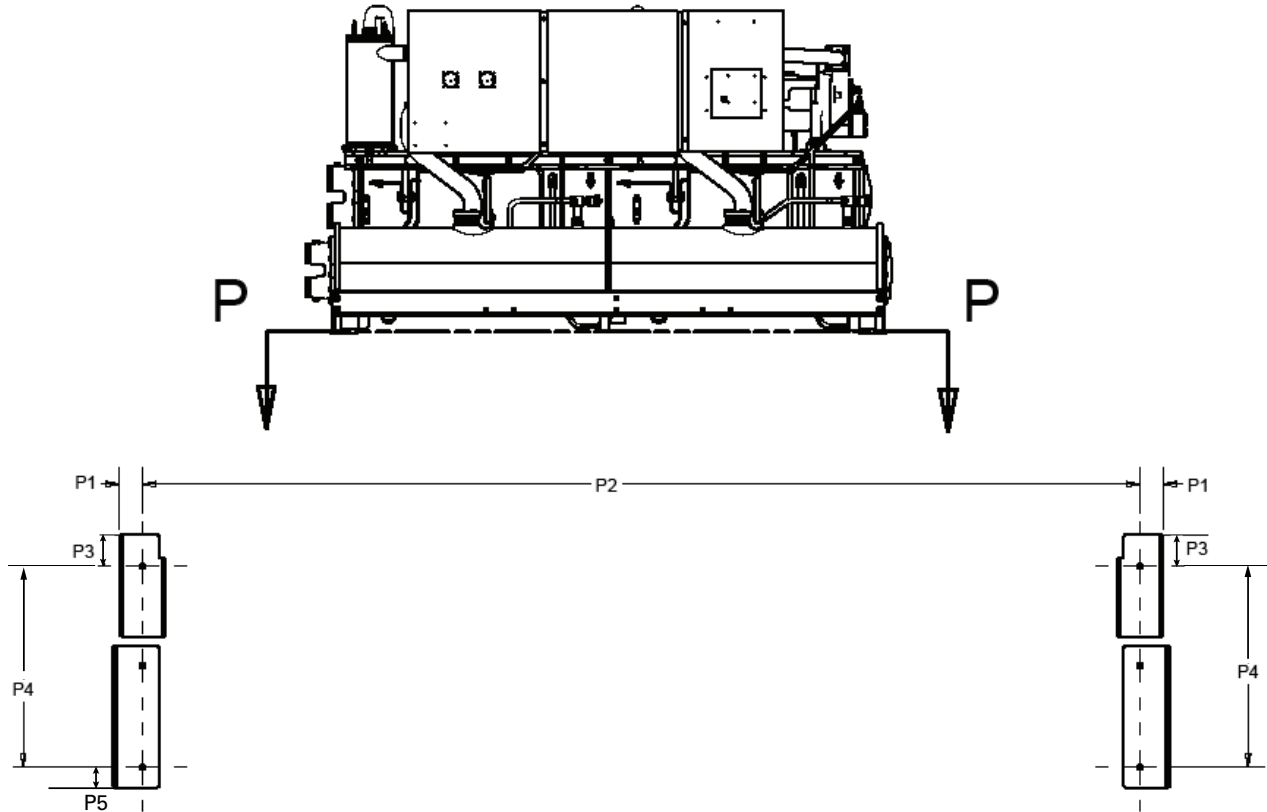

Table 8. RTWD unit footprint

Dimension	Standard Efficiency		High Efficiency 80 - 130T (60Hz)		High Efficiency 150 - 250T (60Hz),		Premium Efficiency 150-200T (60Hz)	
	inch	mm	inch	mm	inch	mm	inch	mm
P1	3.68	93.5	3.68	93.5	3.68	93.5	3.68	93.5
P2	123.78	3144	111.97	2844	111.97	2844	131.65	3344
P3	2.43	61.8	2.43	61.8	4.3	109.3	4.3	109.3
P4	24.93	633.2	24.9	633.2	24.9	633.2	24.9	633.2
P5	2.5	64	2.5	64	2.5	64	2.5	64

Note: Base hole diameters all 0.63 inch (16 mm).

Service Clearance

Figure 4. RTWD service clearances

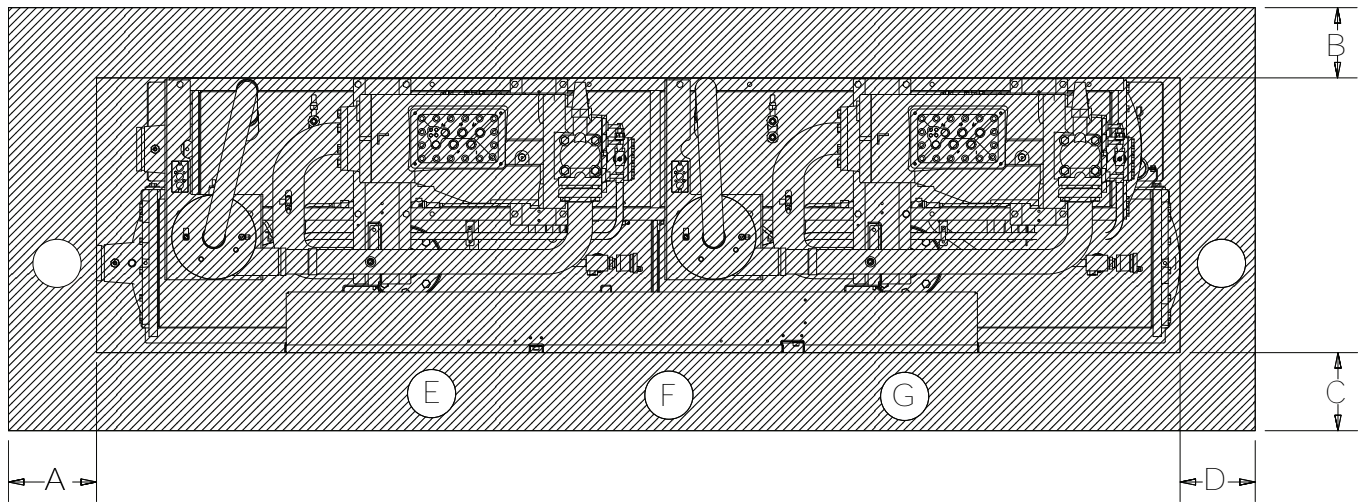

Notes:

- See table below for clearance values.
- All unit configurations require 36 inch (914 mm) clearance above the unit.
- All clearance values are taken from the edge of the unit. Actual unit configuration may vary from that shown in figure above.

Table 9. Service clearances

Unit Configuration			Clearance								Door Swing					
			A ^(a)		B		C ^(b)		D ^(c)		E ^(d)		F ^(e)		G ^(f)	
Tons	Efficiency	Hz	in	mm	in	mm	in	mm	in	mm	in	mm	in	mm	in	mm
80-140	Standard	60	36	914	36	914	36	914	127	3226	31.3	796.9	31.1	790.1	22.4	568.1
70-150	Standard	50														
80-130	High	60	36	914	36	914	36	914	115	2921	31.3	796.9	31.1	790.1	22.4	568.1
60-120	High	50														
150-250	High	60	36	914	36	914	40	1016	114.8	2916	31.3	796.9	31.1	790.1	22.4	568.1
150-200	Premium	60	36	914	36	914	40	1016	134.5	3416	31.3	796.9	31.1	790.1	22.4	568.1

- (a) Condenser supply waterbox end - minimum clearance required for maintenance.
 (b) Clearance of 42 inches (1067 mm) is required to other ground parts. Clearance of 48 inches (1220 mm) required for two units installed with panels facing each other or other live parts.
 (c) Condenser return waterbox end - minimum clearance required for tube removal.
 (d) Door swing - panel power section (left).
 (e) Door swing - panel power section (middle).
 (f) Door swing - panel control section door swing.

RTWD Weights

Table 10. Weights – RTWD, 60 Hz

Model	Standard Efficiency				High Efficiency				Premium Efficiency rating			
	Operating		Shipping		Operating		Shipping		Operating		Shipping	
	lb	kg	lb	kg	lb	kg	lb	kg	lb	kg	lb	kg
80	5900	2676	5703	2587	5732	2600	5551	2518	-	-	-	-
90	5933	2691	5721	2595	5792	2627	5587	2534	-	-	-	-
100	6140	2785	5902	2677	6255	2837	6025	2733	-	-	-	-
110	6332	2872	6074	2755	6475	2937	6208	2816	-	-	-	-



Unit Dimensions and Weights

Table 10. Weights – RTWD, 60 Hz (continued)

Model	Standard Efficiency				High Efficiency				Premium Efficiency rating			
	Operating		Shipping		Operating		Shipping		Operating		Shipping	
	lb	kg	lb	kg	lb	kg	lb	kg	lb	kg	lb	kg
120	6530	2962	6248	2834	6510	2953	6230	2826	-	-	-	-
130	6535	2964	6244	2832	6543	2968	6248	2834	-	-	-	-
140	6971	3162	6649	3016	-	-	-	-	-	-	-	-
150	-	-	-	-	7884	3576	7544	3422	8724	3957	8243	3739
160	-	-	-	-	8395	3808	8036	3645	9171	4160	8691	3942
180	-	-	-	-	8490	3851	8098	3673	9290	4214	8772	3979
200	-	-	-	-	8578	3891	8157	3700	9337	4235	8803	3993
220	-	-	-	-	9493	4306	8995	4080	-	-	-	-
250	-	-	-	-	10071	4568	9478	4299	-	-	-	-

Note: Weights include optional base rail fork lifting. Subtract 300 lbs (136.1 kg) if this option is not selected.



Installation - Mechanical

Location Requirements

Noise Considerations

- Locate the unit away from sound-sensitive areas.
- Install the isolation pads under the unit. See “Unit Isolation and Leveling,” p. 28.
- Install rubber vibration isolators in all water piping.
- Seal all wall penetrations.

Note: Consult an acoustical engineer for critical applications.

Foundation

Provide rigid, non-warping mounting pads or a concrete foundation of sufficient strength and mass to support the applicable operating weight (including completed piping, and full operating charges of refrigerant, oil, and water). See “Unit Dimensions,” p. 18 for unit operating weights. Once in place, the unit must be level within 1/4 inch (6.4 mm) over its length and width. The Trane Company is not responsible for equipment problems resulting from an improperly designed or constructed foundation.

Clearances

Provide enough space around the unit to allow the installation and maintenance personnel unrestricted access to all service points. Refer to submittal drawings for the unit dimensions, to provide sufficient clearance for the opening of control panel doors and unit service. See “Unit Dimensions,” p. 18 and “RTWD Weights,” p. 23 for minimum clearances. In all cases, local codes which require additional clearances will take precedence over these recommendations.

Note: Required vertical clearance above the unit is 36 inch (914.4 mm). There should be no piping or conduit located over the compressor motor. If the unit configuration requires a variance to the clearance dimensions, contact your Trane Sales Office Representative. Also refer to Trane Engineering Bulletins for application information on RTWD chillers.

Ventilation

The unit produces heat although the compressor is cooled by the refrigerant. Make provisions to remove heat generated by unit operation from the equipment room. Ventilation must be adequate to maintain an ambient temperature lower than 104°F (40°C). Vent the evaporator and condenser pressure relief valves in accordance with all local and national codes. Make provisions in the equipment room to keep the chiller from being exposed to freezing temperatures (32°F/0°C).

Rigging

Confirm unit is secure from tipping using one of the following (or similar) methods:

- Secure to dunnage.
- Secure to building.
- Add 2-inch schedule 40 pipes. Refer the table below and the following figures to determine the pipe length.

Table 11. Outrigger/Pipe lengths

Description	Length (mm)				
	0	100	150	200	250
H - Moving skid, skate, or other moving apparatus height					
L1 - Outrigger length	200	800	1100	1400	1700
L2 - Steel pipe length	690	1890	2490	3090	3690

Figure 5. RTWD – anti tipping

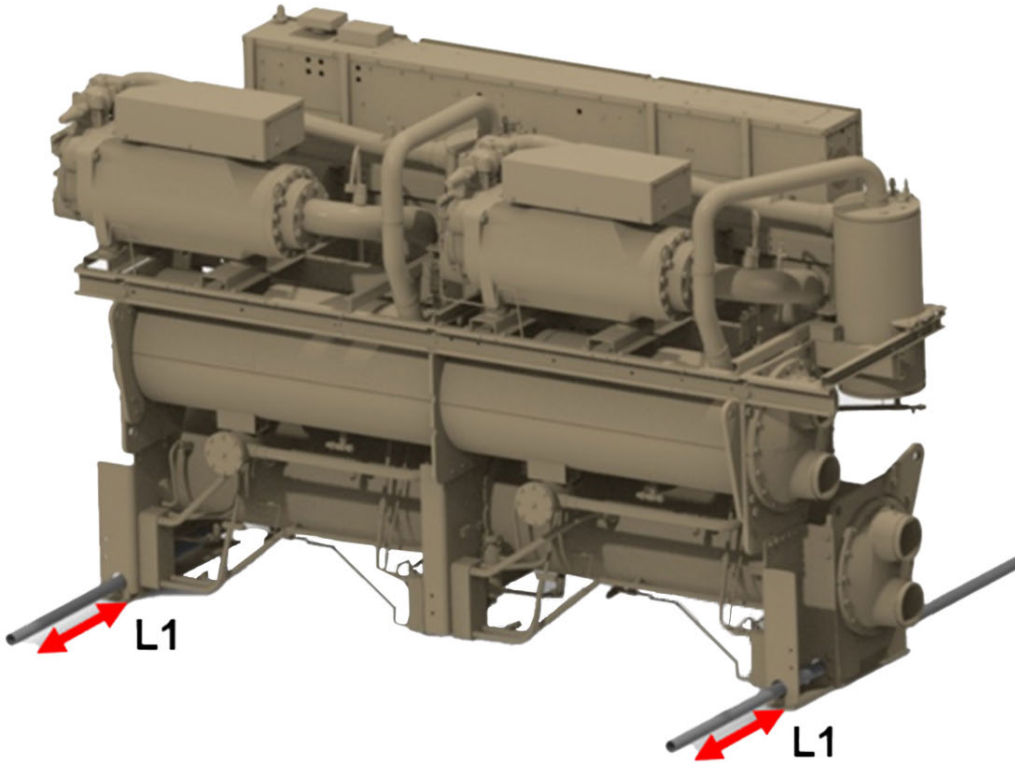

Figure 6. RTWD – anti tipping

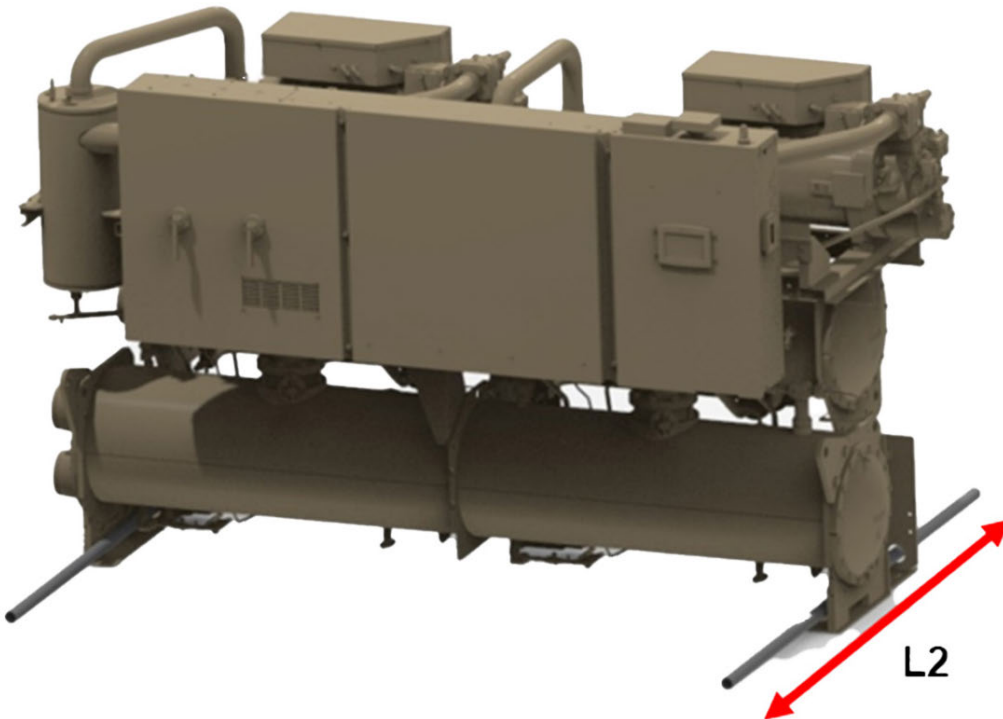
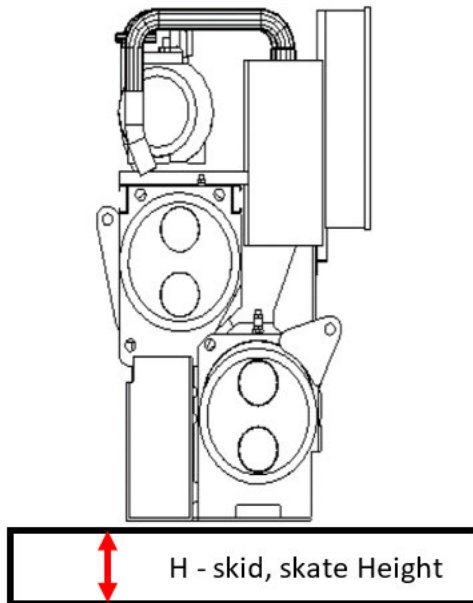

Figure 7. RTWD – anti tipping



The chiller should be moved by lifting, unless the unit is ordered with the base rail forklifting option. Refer to the unit model number, digit 46, for more details.

See thru “RTWD Weights,” p. 23 for typical unit lifting weights Refer to the rigging label attached to the unit for further details.

Figure 8. Equipment is top heavy (see warning above)

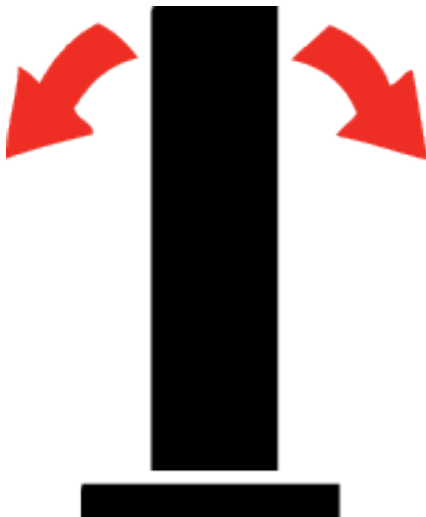

⚠ WARNING

Heavy Objects!

Failure to follow instructions below or properly lift unit could result in unit dropping and possibly crushing operator/technician which could result in death or serious injury, and equipment or property-only damage.

- Equipment is top heavy. Use caution when lifting/ moving equipment to prevent unit from tipping.
- Ensure that all the lifting equipment used is properly rated for the weight of the unit being lifted. Each of the cables (chains or slings), hooks, and shackles used to lift the unit must be capable of supporting the entire weight of the unit. Lifting cables (chains or slings) may not be of the same length. Adjust as necessary for even unit lift.
- The high center of gravity on this unit requires the use of an anti-rolling cable (chain or sling). To prevent unit from rolling, attach cable (chain or sling) with no tension and minimal slack around compressor suction pipe as shown.
- Do not use forklift to move or lift unit unless unit has lifting base with base rail forklifting option.

⚠ WARNING

Improper Unit Lift!

Failure to properly lift unit in a LEVEL position could result in unit dropping and possibly crushing operator/technician which could result in death or serious injury, and equipment or property-only damage.

Test lift unit approximately 24 inches (61 cm) to verify proper center of gravity lift point. To avoid dropping of unit, reposition lifting point if unit is not level.

Lifting Procedure

Attach chains or cables to lifting beam, as shown in [Figure 9, p. 28](#). Lifting beam crossbars MUST be positioned so lifting cables do not contact the sides of the unit. Attach the anti-rolling cable to the circuit 2 compressor suction pipe. Adjust as necessary for even level lift.

Figure 9. RTWD rigging

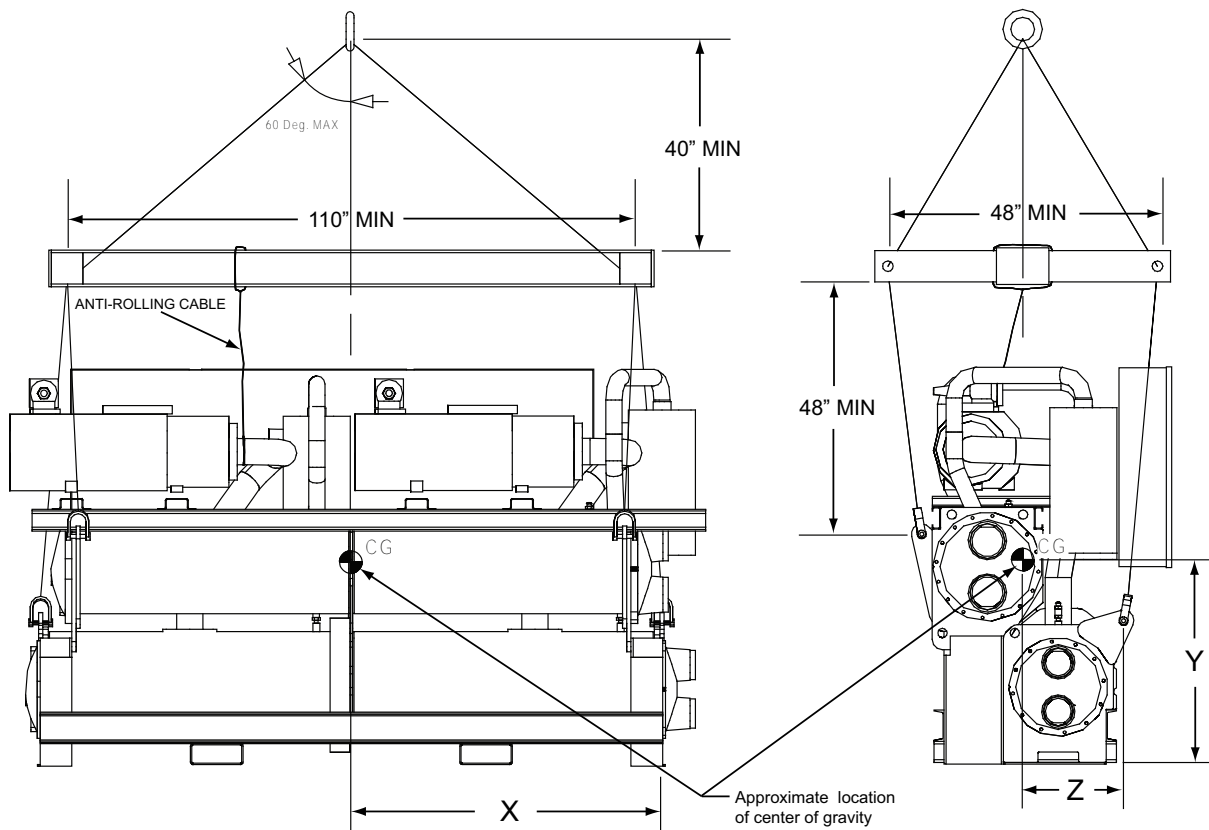

Unit Isolation and Leveling

Mounting

Construct an isolated concrete pad for the unit or provide concrete footings at each of the four unit mounting points.

Mount the unit directly to the concrete pads or footings. Level the unit using the base rail as a reference. The unit must be level within 1/4 inch over the entire length and width. Use shims as necessary to level the unit.

Isolation Pads

Note: The elastomeric pads shipped (as standard) are adequate for most installations. Consult an acoustical engineer for sound-sensitive installations.

During final positioning of the unit, place the isolation pads under the evaporator and condenser tube sheet supports as shown in [Figure 10](#), p. 29. Level the unit as described in the next main paragraph.

Figure 10. Isolator pad placement

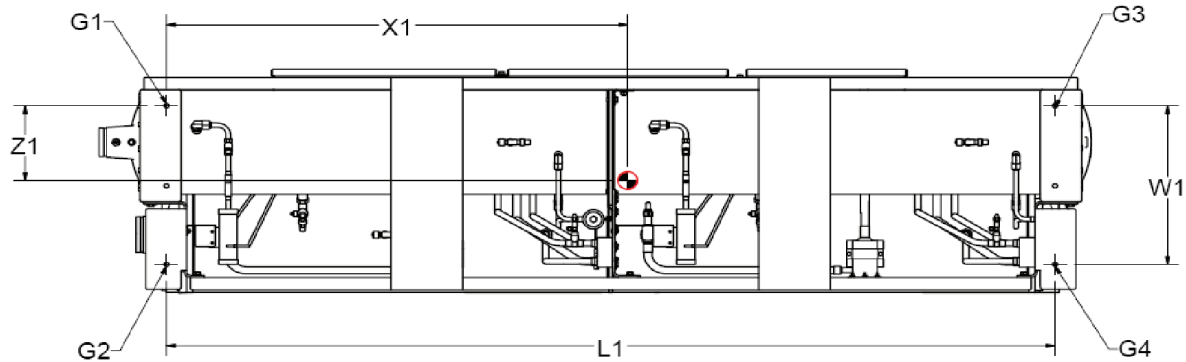

NOTE: Unit level to 1/4-inch (6.35mm) across width and length.

Neoprene Isolator Installation (optional)

Install the optional neoprene isolators at each mounting location. Isolators are identified by part number and color. Refer to submittal drawing for correct isolators.

1. Secure the isolators to the mounting surface, using the mounting slots in the isolator base plate, as shown in [Figure 11](#), p. 29. Do not fully tighten the isolator mounting bolts at this time.
2. Align the mounting holes in the base of the unit with the threaded positioning pins on the top of the isolators.
3. Lower the unit on the isolators and secure the isolator to the unit with a nut.
4. Level the unit carefully. See "[Unit Isolation and Leveling](#)," p. 28. Fully tighten the isolator mounting bolts.

Figure 11. RTWD neoprene isolator

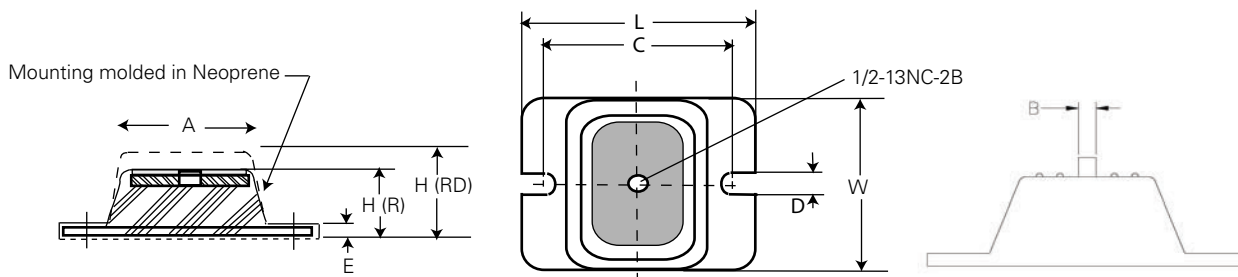

Table 12. Isolator part numbers and dimensions

Size	Hz	Effic.	Isolator Type Color [Ext] ^(a) Max Load-lbs (kg)	Maximum Deflection (in)	Dimension - in (mm)							
					A	B	C	D	E	H	L	W
80, 90, 100, 110, 120, 130, 140	60	STD	RDP-4 Red [62] 2250 (1021)	0.50	3.0	0.50	5.00	0.56	0.38	2.75	6.25	4.63
80, 90, 100, 110, 120, 130	60	HIGH			(76.2)	(12.7)	(127.0)	(14.2)	(9.7)	(69.8)	(158.8)	(117.6)
150, 160, 180, 200, 220, 250	60	HIGH	RDP-4 Green [63] 3000 (1361)	0.50	3.0	0.50	5.00	0.56	0.38	2.75	6.25	4.63
150, 160, 180, 200	60	PREM			(76.2)	(12.7)	(127.0)	(14.2)	(9.7)	(69.8)	(158.8)	(117.6)

Note: See submittal drawing to verify correct isolators.

^(a) Part number is X10140305-xx

Corner Weights

Figure 12. Mounting point locations and weights – RTWD Std efficiency (all), RTWD High efficiency: 80 - 120T (60 Hz)

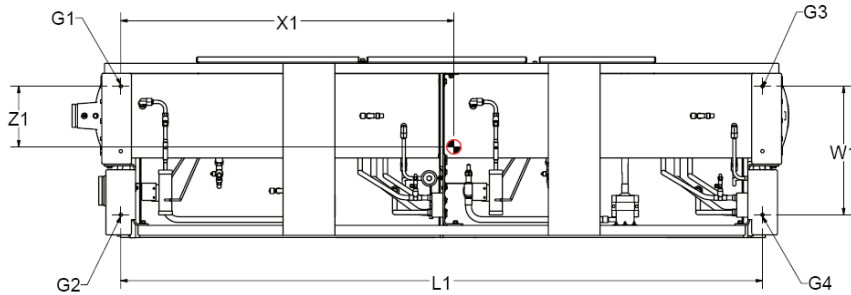
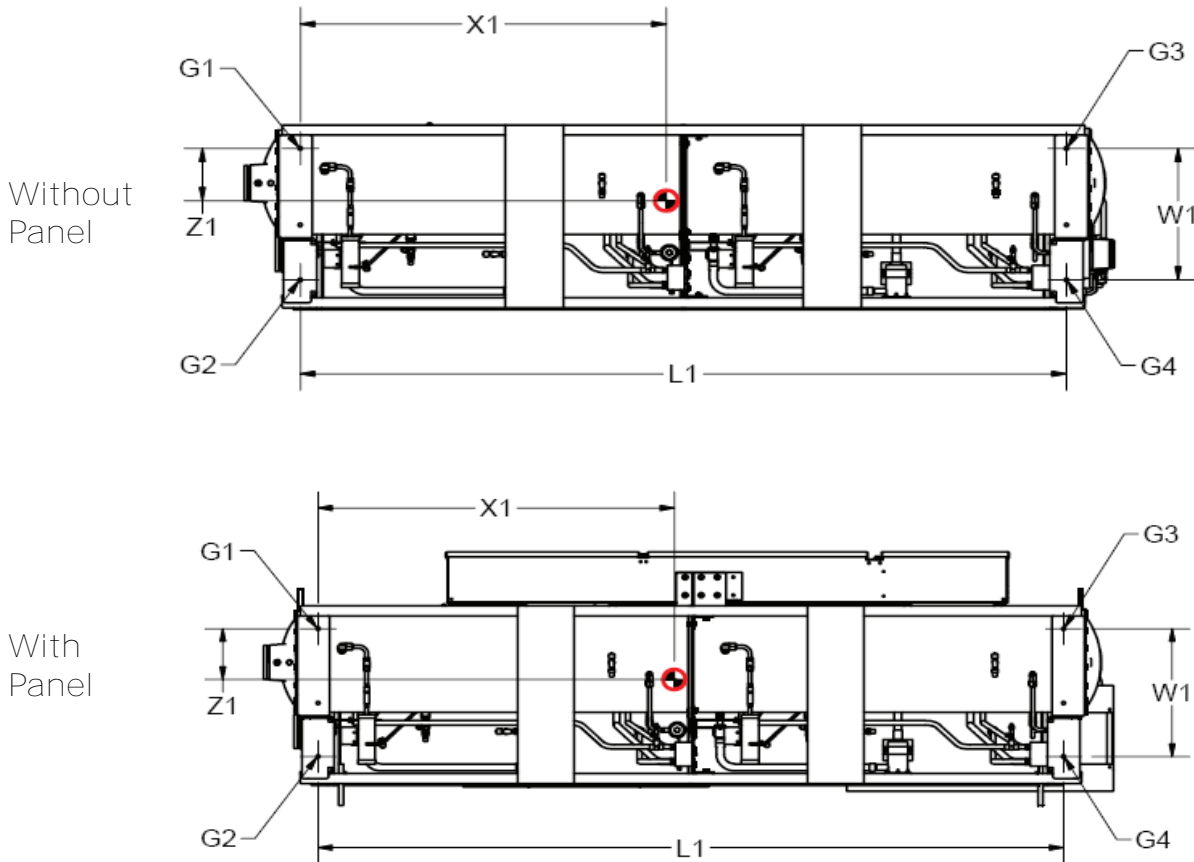

Figure 13. Mounting point locations and weights – RTWD Premium efficiency (all), RTWD High efficiency: 150 – 250T (60 Hz)



Important: Isolators need to be placed under G1, G2, G3 and G4.

Table 13. Corner weights, RTWD, 60 Hz

Unit	G1		G2		G3		G4	
	lb	kg	lb	kg	lb	kg	lb	kg
Standard Efficiency								
80	1566	710	1566	710	1385	628	1385	628
90	1571	713	1577	715	1390	630	1396	633
100	1599	725	1617	733	1454	660	1471	667
110	1662	754	1690	767	1477	670	1503	681
120	1689	766	1795	814	1477	670	1569	712
130	1688	765	1797	815	1478	670	1573	713
140	1654	750	1905	864	1586	719	1827	829
High Efficiency								
80	1465	664	1595	724	1279	580	1393	632
90	1479	671	1610	730	1294	587	1409	639
100	1602	726	1704	773	1429	648	1521	690
110	1673	759	1789	811	1457	661	1557	706
120	1680	762	1798	816	1465	664	1569	711
130	1685	764	1808	820	1472	668	1580	716
150	1181	535	2010	911	1937	878	2070	939

Table 13. Corner weights, RTWD, 60 Hz (continued)

Unit	G1		G2		G3		G4	
	lb	kg	lb	kg	lb	kg	lb	kg
160	1987	901	2261	1025	1946	883	2215	1004
180	2002	908	2284	1036	1969	893	2246	1019
200	2020	916	2309	1047	1989	902	2273	1031
220	2171	985	2515	1141	2226	1010	2579	1170
250	2256	1023	2728	1237	2296	1041	2776	1259
Premium Efficiency								
150	2089	947	2195	996	2171	985	2281	1035
160	2173	985	2416	1096	2176	987	2420	1097
180	2194	995	2454	1113	2198	997	2458	1115
200	2207	1001	2461	1116	2213	1004	2468	1119

Evaporator Water Piping

Figure 14. Typical water piping setup

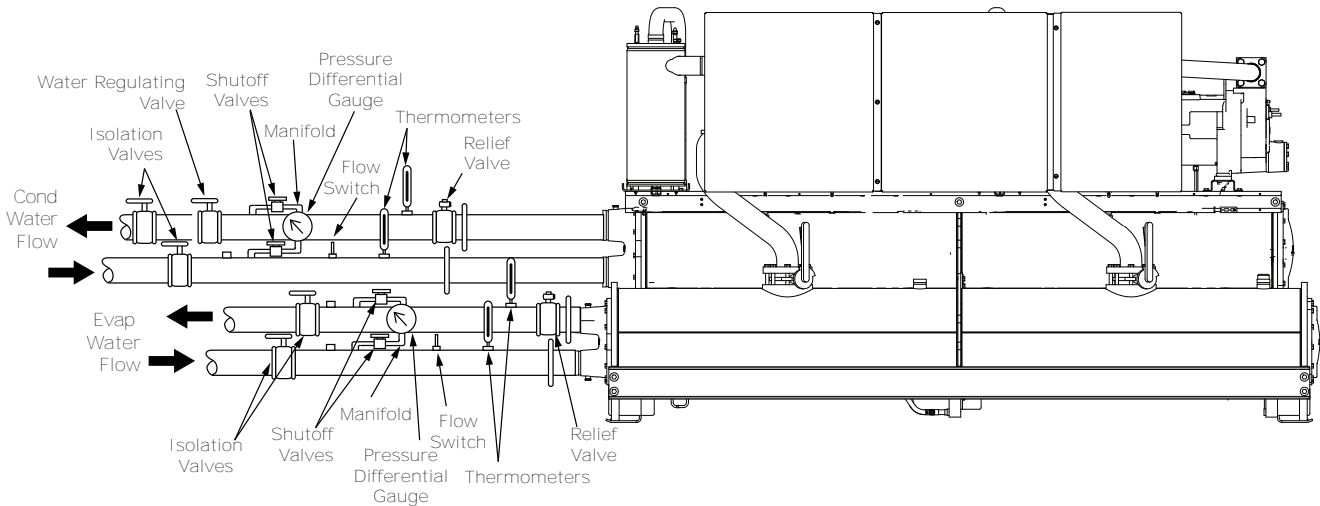

Thoroughly flush all water piping to the unit before making the final piping connections to the unit.

Components and layout will vary slightly, depending on the location of connections and the water source.

NOTICE

Evaporator Damage!

Failure to follow instructions below could cause damage to the evaporator.

The chilled water connections to the evaporator are to be grooved-pipe type connections. Do not attempt to weld these connections, as the heat generated from welding can cause microscopic and macroscopic fractures on the cast iron waterboxes that can lead to premature failure of the waterbox. To prevent damage to chilled water components, do not allow evaporator pressure (maximum working pressure) to exceed 150 psig (10.5 bar).

NOTICE

Equipment Damage!

Failure to follow instructions below could result in damage to internal components of the evaporator. If using an acidic commercial flushing solution when flushing the water piping, construct a temporary bypass around the unit.

NOTICE

Water Borne Debris!

To prevent components damage, pipe strainers must be installed in the water supplies to protect components from water borne debris. Trane is not responsible for equipment-only-damage caused by water borne debris.

NOTICE

Proper Water Treatment Required!

The use of untreated or improperly treated water could result in scaling, erosion, corrosion, algae or slime.

Use the services of a qualified water treatment specialist to determine what water treatment, if any, is required. Trane assumes no responsibility for equipment failures which result from untreated or improperly treated water, or saline or brackish water.

Locate the unit near a large capacity drain for water vessel drain-down during shutdown or repair. Condensers and

evaporators are provided with drain connections. All local and national codes apply.

A vent is provided on the top of the evaporator at the return end. Be sure to provide additional vents at high points in the piping to bleed air from the chilled water system. Install necessary pressure gauges to monitor the entering and leaving chilled water pressures.

Provide shutoff valves in lines to the gauges to isolate them from the system when they are not in use. Replace rubber vibration eliminators to in-line elastomeric vibration eliminator.

Figure 15. RTWD installation

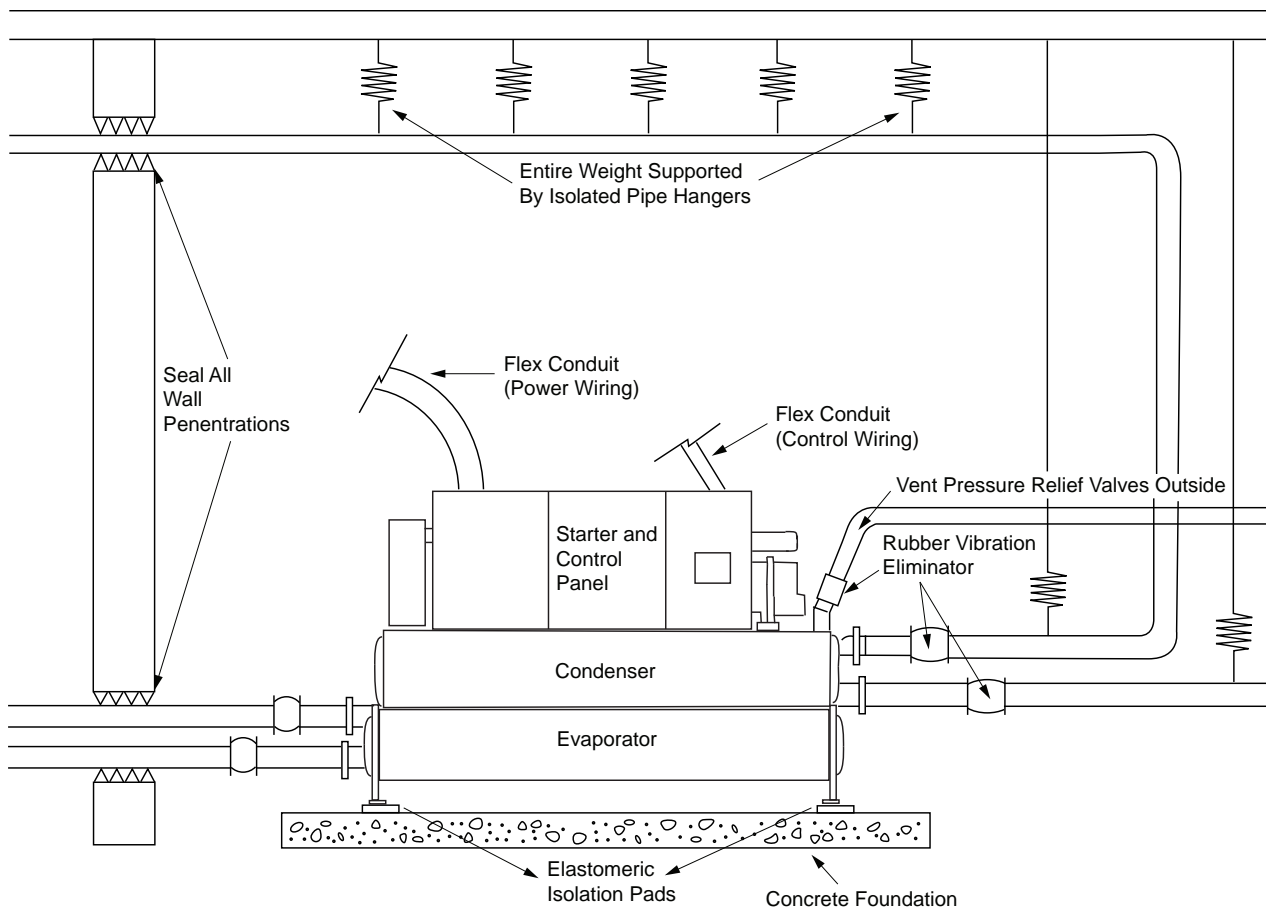

If desired, install thermometers in lines to monitor entering and leaving water temperatures. Install a balancing valve in leaving water line to control water flow balance. Install shutoff valves on both entering and leaving water lines to isolate evaporator for service.

A pipe strainer must be installed in entering water line to prevent water-borne debris from entering the evaporator.

Reversing Waterboxes

NOTICE

Equipment Damage!

Altering waterboxes can affect equipment operation and can cause equipment damage.

Do NOT rotate or swap evaporator or condenser waterboxes end-for-end.

Waterboxes on evaporator and condenser can NOT be rotated or swapped end for end. Altering waterboxes will

lead to poor efficiency, poor oil management and possible freeze-up of evaporator.

Figure 16. RTWD waterboxes

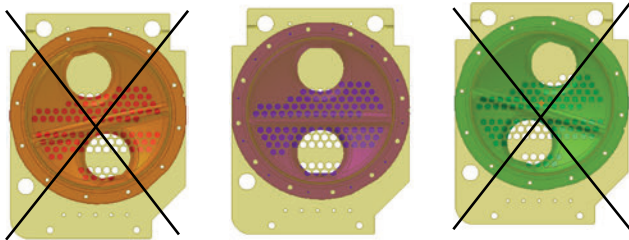

Evaporator Piping Components

Piping components include all devices and controls used to provide proper water system operation and unit operating safety. These components and their general locations are given below.

Drain and Vents

NOTICE

Waterbox Damage!

Failure to follow instructions could result in damage to the waterbox.

Do not over-tighten or use excessive Teflon® pipe tape when installing valves, drains, plugs and vents on waterboxes.

Drains and vents are located on each evaporator waterbox. When the unit is shipped, the drain plugs are removed and placed in a plastic bag in the control panel, along with the condenser drain plugs. Each drain and vent must be piped with a shutoff valve, or plug reinstalled, prior to water pump operation.

Entering Chilled Water Piping - Field Installed

- Air vents (to bleed air from system)
- Water pressure gauges with shutoff valves
- Vibration eliminators
- Shutoff (isolation) valves
- Thermometers (if desired)
- Cleanout tees
- Relief valve
- Pipe strainer

NOTICE

Water Borne Debris!

To prevent components damage, pipe strainers must be installed in the water supplies to protect components from water borne debris. Trane is not responsible for equipment-only-damage caused by water borne debris.

NOTICE

Evaporator Damage!

Failure to follow instructions below could cause damage to the evaporator.

The chilled water connections to the evaporator are to be grooved-pipe type connections. Do not attempt to weld these connections, as the heat generated from welding can cause microscopic and macroscopic fractures on the cast iron waterboxes that can lead to premature failure of the waterbox. To prevent damage to chilled water components, do not allow evaporator pressure (maximum working pressure) to exceed 150 psig (10.5 bar).

Leaving Chilled Water Piping - Field Installed

- Air vents (to bleed air from system)
- Water pressure gauges with shutoff valves
- Vibration eliminators
- Shutoff (isolation) valves
- Thermometers
- Cleanout tees
- Balancing valve
- Flow Switch (not required if factory installed flow switch option is selected)

Evaporator Flow Switch (Optional)

If factory installed flow switch option is selected, switch is programmed based on the operating conditions submitted with the order. The leaving evaporator temperature, fluid type and fluid concentration affect the selected flow switch. If the operating conditions on the job site change, the flow switch may need to be replaced.

The flow switch is powered with 24 Vac. Indicators on switch are as follows:

- Green - power is applied
- Amber - always off

NOTICE

Proper Water Treatment Required!

The use of untreated or improperly treated water could result in scaling, erosion, corrosion, algae or slime.

Use the services of a qualified water treatment specialist to determine what water treatment, if any, is required. Trane assumes no responsibility for equipment failures which result from untreated or improperly treated water, or saline or brackish water.

***Important:** If using an acidic commercial flushing solution, construct a temporary bypass around the unit to prevent damage to internal components of the evaporator and condenser.*

Dirt, scale, products of corrosion, and other foreign material will adversely affect heat transfer between the water and system components. Foreign matter in the chilled water system can also increase pressure drop and, consequently, reduce water flow. Proper water treatment must be determined locally, depending on the type of system and local water characteristics.

Neither salt nor brackish water is recommended for use in Trane air-cooled Series R® chillers. Use of either will lead to a shortened life to an indeterminable degree. Trane Technologies encourages to have a reputable water treatment specialist, familiar with local water conditions, to assist in this determination and in the establishment of a proper water treatment program.

Using untreated or improperly treated water in these units may result in inefficient operation and possible tube damage. Consult a qualified water treatment specialist to determine whether treatment is needed.

Indexing Flow Switch

To properly index the flow switch, the following requirements must be met:

- The dot must be at a position no greater than 90° off Index.
- The torque must be between 22 ft-lb minimum and 74 ft-lb maximum.
- A minimum distance of 5x pipe diameter must be maintained between flow switch and any bends, valves, changes in cross sections, etc.

Figure 17. Proper flow switch indexing

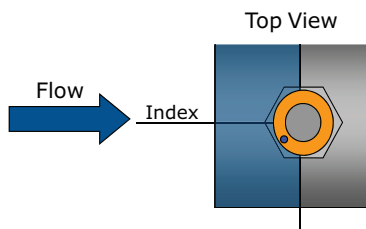

The flow switch must have the dot in the shaded area to the left of this line for proper indexing ($\pm 90^\circ$ off Index)

Flow Proving Devices

Important: If factory installed flow switch option is not selected, installer must provide flow switches or differential pressure switches with pump interlocks to prove water flow.

To provide chiller protection, install and wire flow switches in series with the water pump interlocks, for both chilled water and condenser water circuits. See *Installation Electrical* chapter. Specific connections and schematic wiring diagrams are shipped with the unit.

Flow switches must prevent or stop compressor operation if system water flow falls below the required minimum shown on the pressure drop curves. Follow the manufacturer's recommendations for selection and installation procedures. General guidelines for flow switch installation are outlined below.

- Mount the switch upright, with straight horizontal runs on either side. The length of the horizontal runs should be a minimum of 5 pipe diameters.

- Do not install close to elbows, orifices, or valves.

Note: The arrow on switch must point in direction of water flow.

- To prevent switch fluttering, remove all air from water system.

Note: Chiller control provides a 6-sec time delay on flow switch input before shutting down unit on loss-of-flow diagnostic. Contact a qualified service organization if the machine shutdown persists.

- Adjust switch to open when water flow falls below minimum required. See "General Data," p. 10 tables for minimum flow recommendations. Flow switch is closed on proof of water flow.

NOTICE

Evaporator Damage!

Failure to follow instructions could result in evaporator damage.

To prevent evaporator damage, do not use water flow switch to cycle the system.

Pressure Drop Curves

For overlapping pressure drop curves, see "General Data," p. 10 tables for limit values.



Installation - Mechanical

Figure 18. Evaporator pressure drop curves - 2 pass, 60 Hz - RTWD

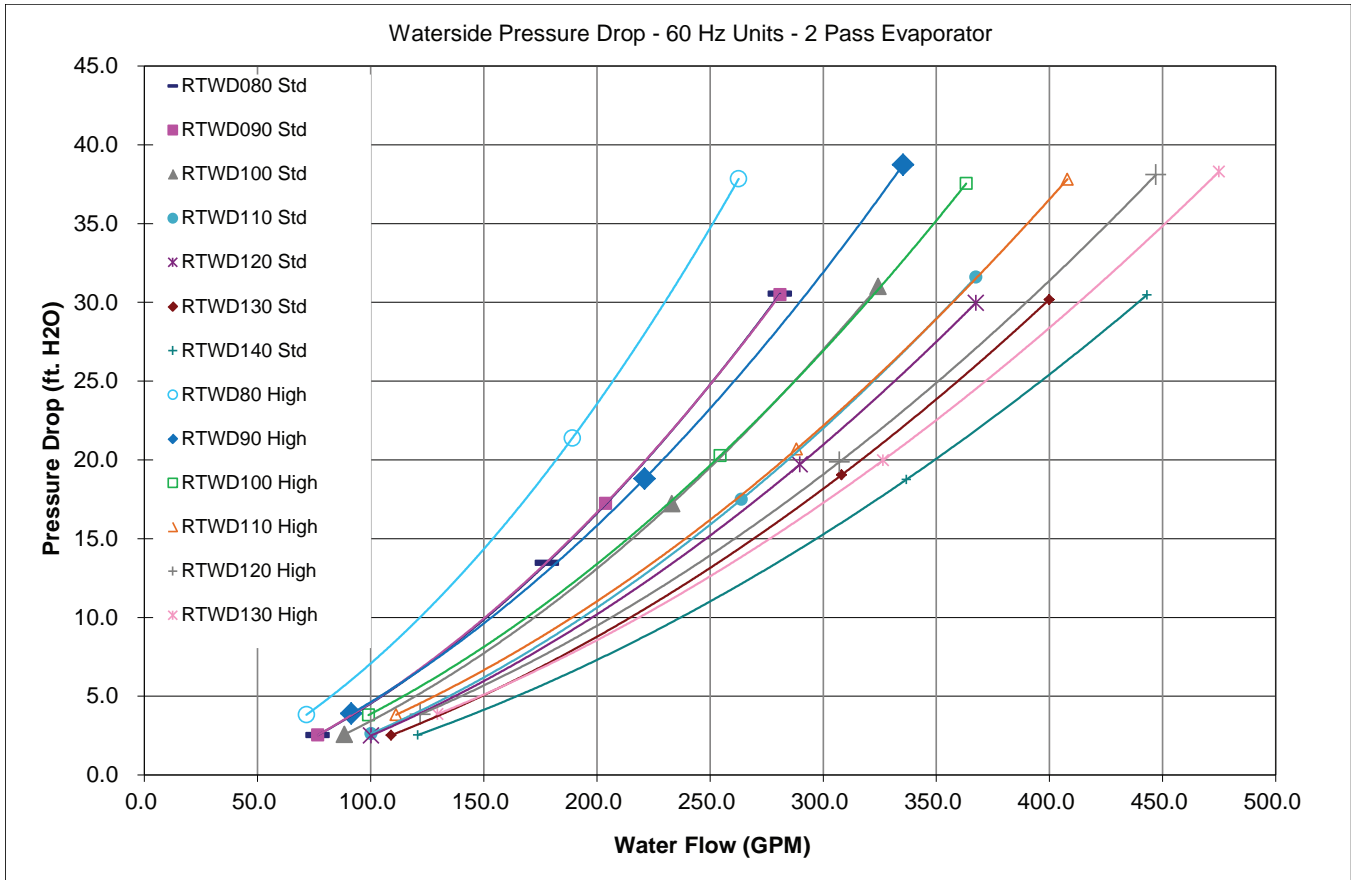
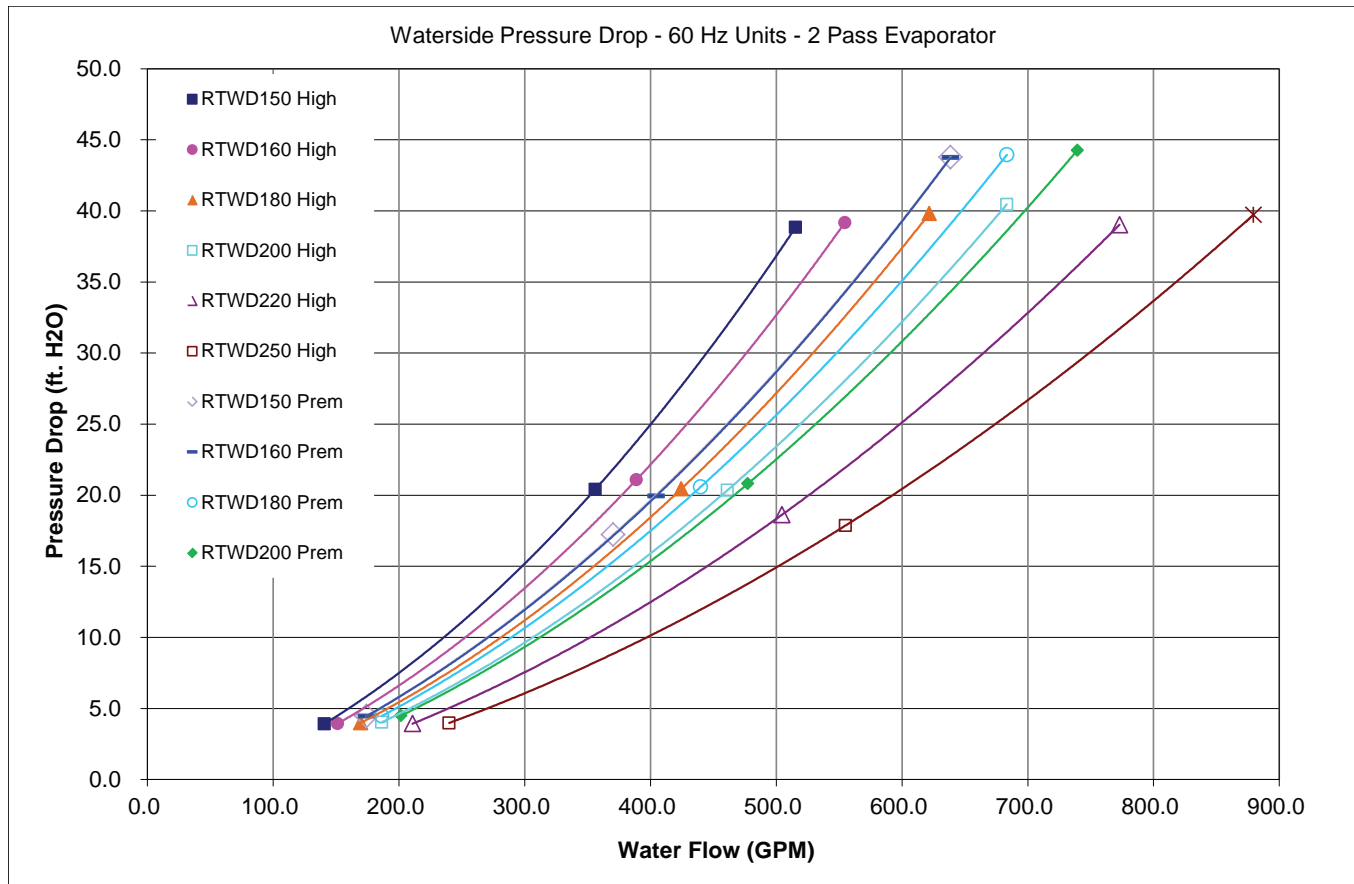

Figure 19. Evaporator pressure drop curves - 2 pass, 60 Hz - RTWD





Installation - Mechanical

Figure 20. Evaporator pressure drop curves - 3 pass, 60 Hz - RTWD

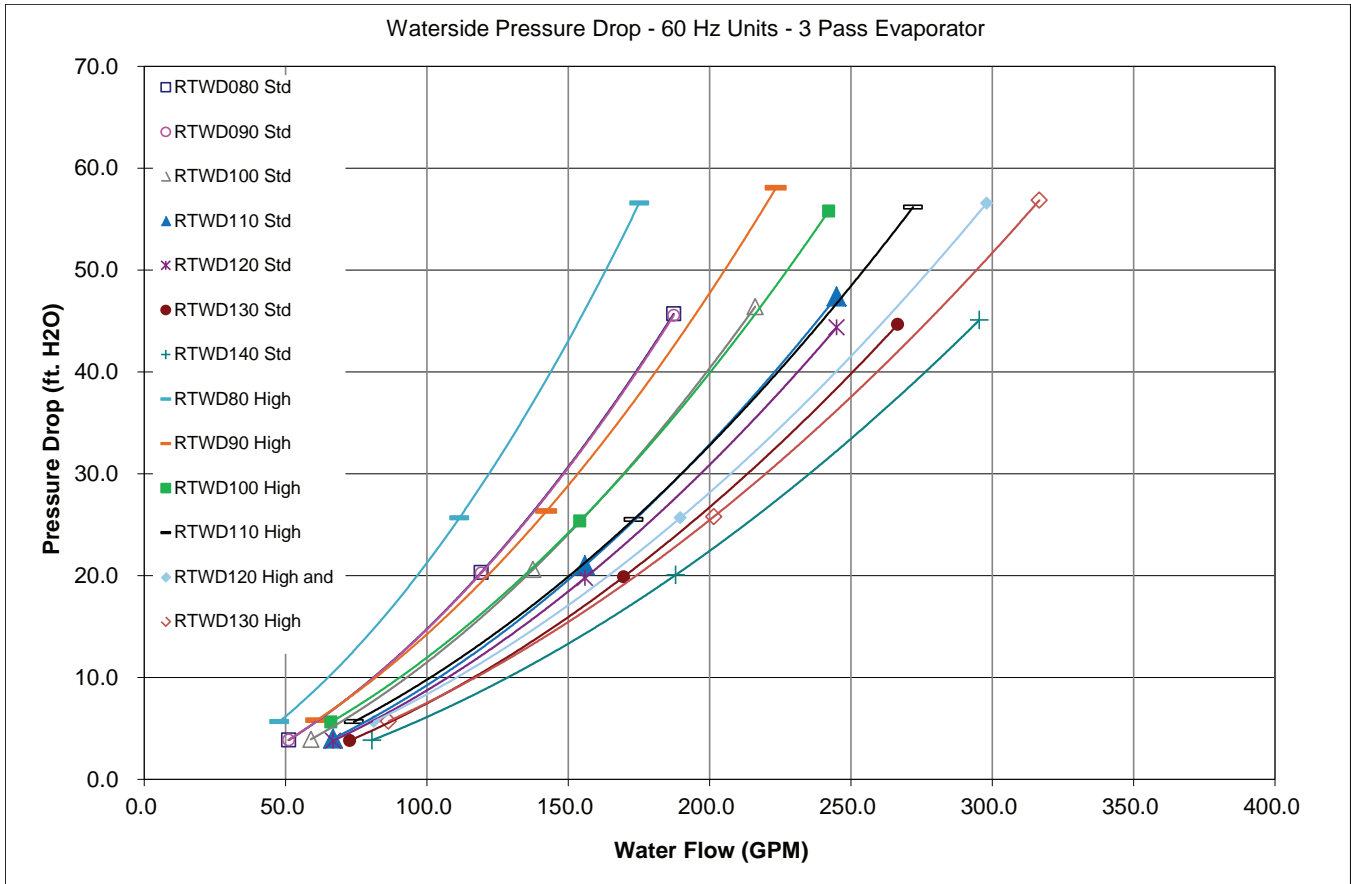
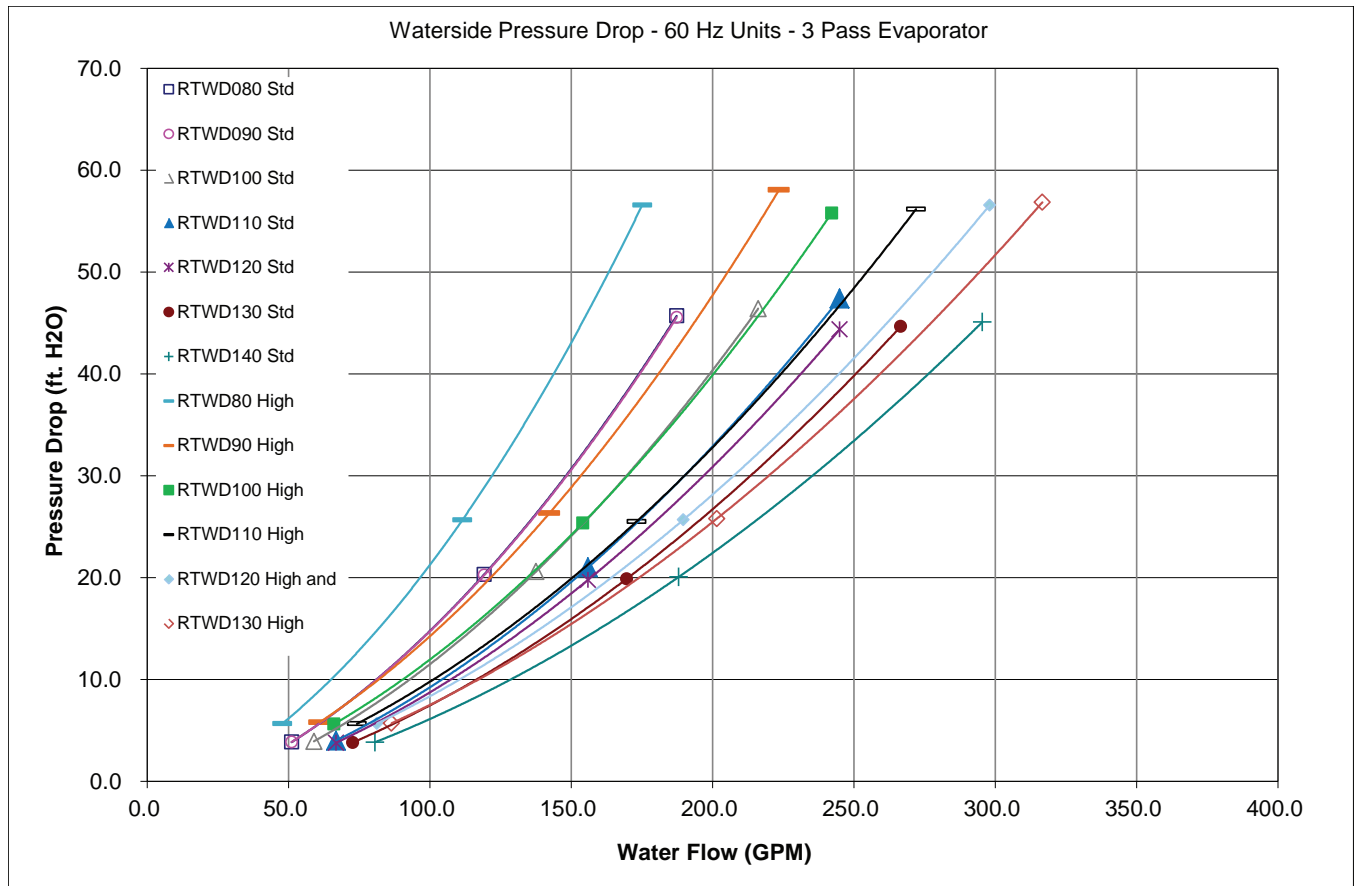

Figure 21. Evaporator pressure drop curves - 3 pass, 60 Hz - RTWD





Installation - Mechanical

Figure 22. Condenser pressure drop curves - RTWD 60 Hz

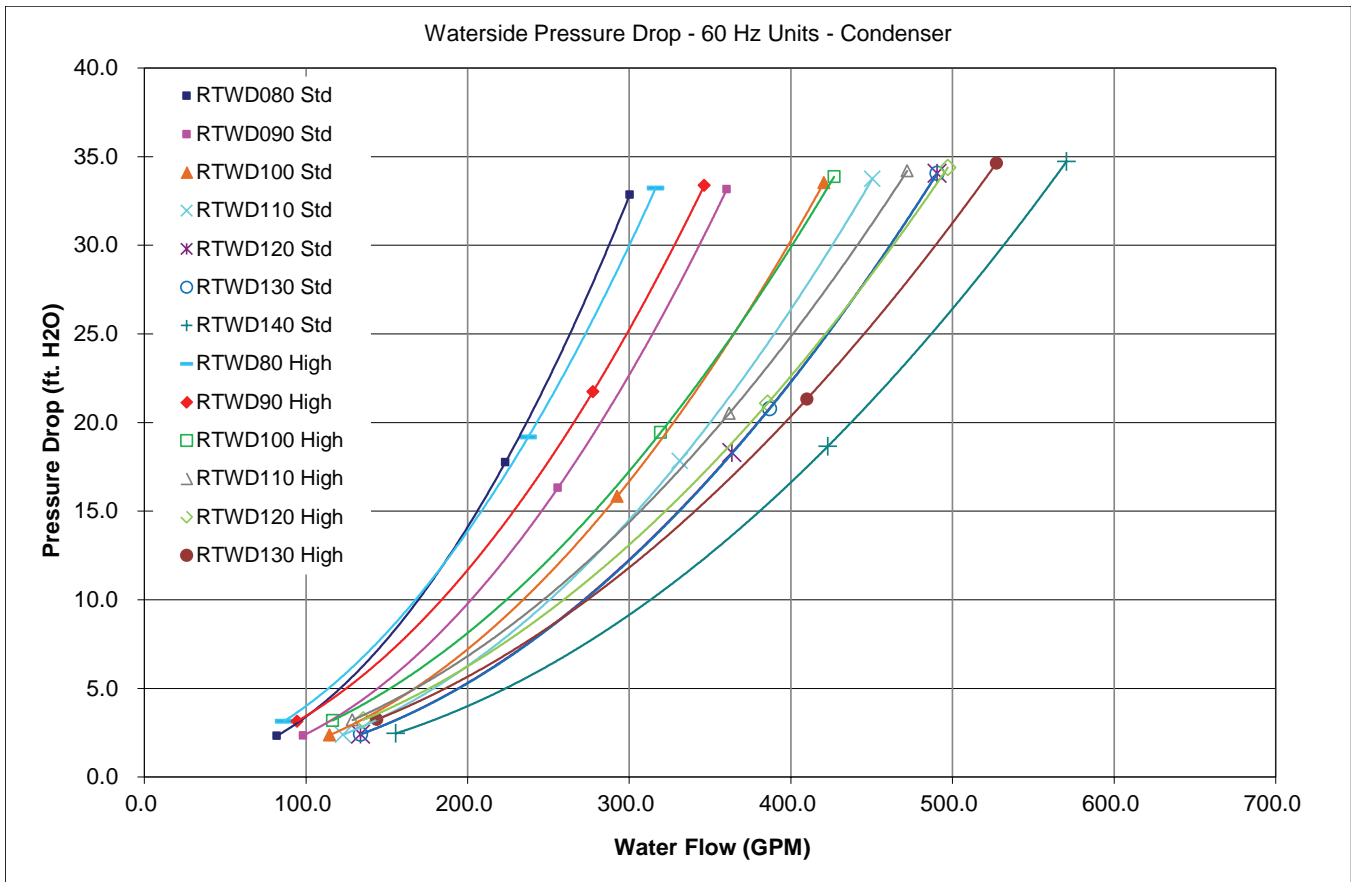
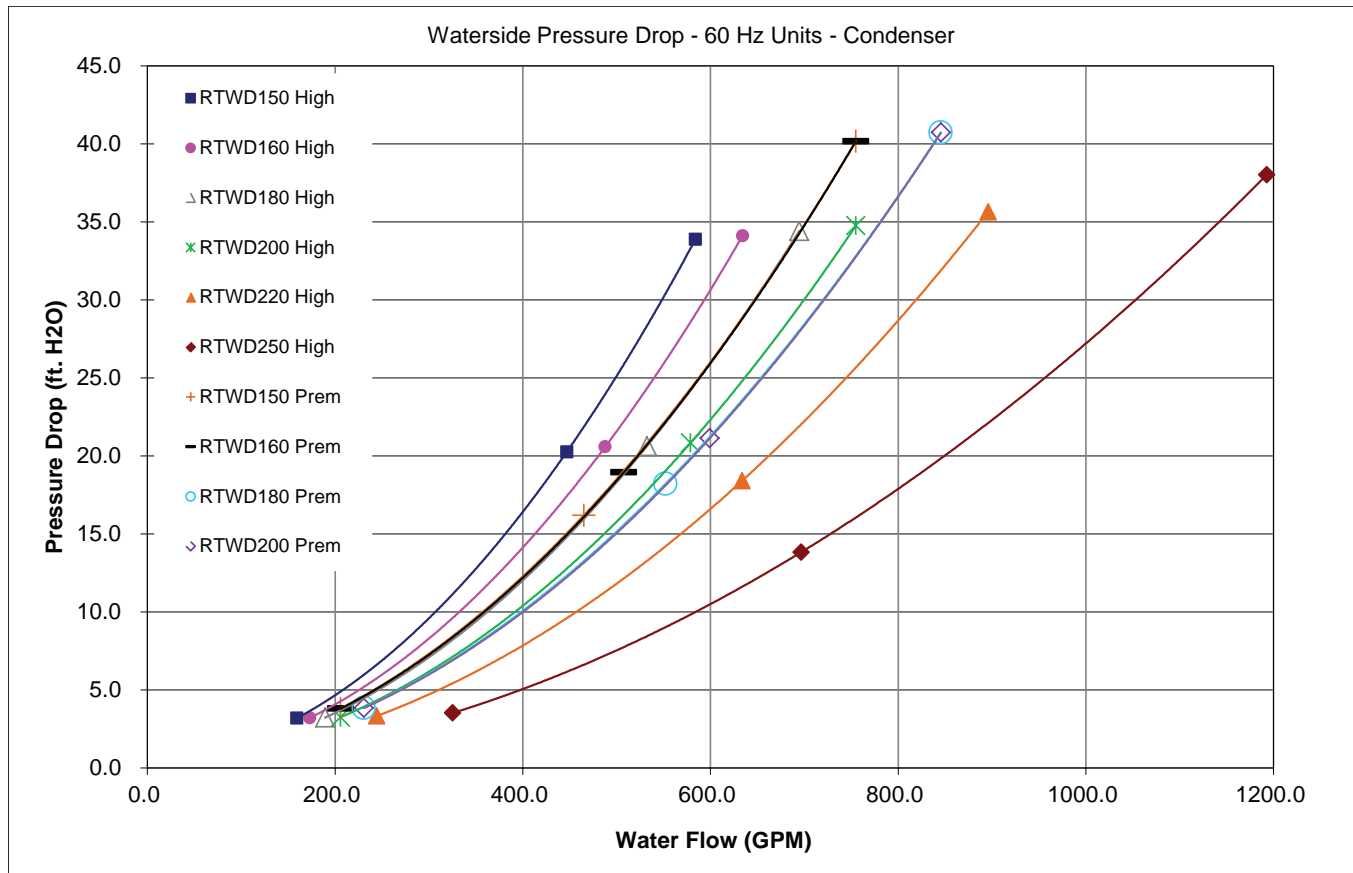

Figure 23. Condenser pressure drop curves - RTWD 60 Hz



Low Evaporator Refrigerant Cutout, Percent Glycol Requirements

The tables below show the low evaporator temperature cutout for different glycol levels. Additional glycol beyond

the recommendations will adversely affect unit performance. The unit efficiency will be reduced and the saturated evaporator temperature will be reduced. For some operating conditions this effect can be significant.

If additional glycol is used, then use the actual percent to establish the low refrigerant cutout setpoint.

Table 14. Low evaporator refrigerant temperature cutout (LRTC) and low water temperature cutout (LWTC) – ethylene or propylene glycol

Ethylene Glycol				Propylene Glycol			
Inhibitor Percentage (%)	Solution Freeze Point (°F)	Minimum Recommended LRTC (°F)	Minimum Recommended LWTC (°F)	Inhibitor Percentage (%)	Solution Freeze Point (°F)	Minimum Recommended LRTC (°F)	Minimum Recommended LWTC (°F)
0	32.0	28.6	35.0	0	32.0	28.6	35.0
2	31.0	27.6	34.0	2	31.0	27.6	34.0
4	29.7	26.3	32.7	4	29.9	26.5	32.9
5	29.0	25.6	32.0	5	29.3	25.9	32.3
6	28.3	24.9	31.3	6	28.7	25.3	31.7
8	26.9	23.5	29.9	8	27.6	24.2	30.6
10	25.5	22.1	28.5	10	26.4	23.0	29.4
12	23.9	20.5	26.9	12	25.1	21.7	28.1
14	22.3	18.9	25.3	14	23.8	20.4	26.8



Installation - Mechanical

Table 14. Low evaporator refrigerant temperature cutout (LRTC) and low water temperature cutout (LWTC) – ethylene or propylene glycol (continued)

Ethylene Glycol				Propylene Glycol			
Inhibitor Percentage (%)	Solution Freeze Point (°F)	Minimum Recommended LRTC (°F)	Minimum Recommended LWTC (°F)	Inhibitor Percentage (%)	Solution Freeze Point (°F)	Minimum Recommended LRTC (°F)	Minimum Recommended LWTC (°F)
15	21.5	18.1	24.5	15	23.1	19.7	26.1
16	20.6	17.2	23.6	16	22.4	19.0	25.4
18	18.7	15.3	21.7	18	20.9	17.5	23.9
20	16.8	13.4	19.8	20	19.3	15.9	22.3
22	14.7	11.3	17.7	22	17.6	14.2	20.6
24	12.5	9.1	15.5	24	15.7	12.3	18.7
25	11.4	8.0	14.4	25	14.8	11.4	17.8
26	10.2	6.8	13.2	26	13.8	10.4	16.8
27	9.0	5.6	12.0	27	12.7	9.3	15.7
28	7.7	4.3	10.7	28	11.6	8.2	14.6
29	6.4	3.0	9.4	29	10.5	7.1	13.5
30	5.1	1.7	8.1	30	9.3	5.9	12.3
32	2.3	-1.1	5.3	32	6.8	3.4	9.8
34	-0.7	-4.1	5.0	34	4.1	0.7	7.1
35	-2.3	-5.0	5.0	35	2.7	-0.7	5.7
36	-3.9	-5.0	5.0	36	1.3	-2.1	5.0
38	-7.3	-5.0	5.0	38	-1.8	-5.0	5.0
40	-10.8	-5.0	5.0	40	-5.2	-5.0	5.0
42	-14.6	-5.0	5.0	42	-8.8	-5.0	5.0
44	-18.6	-5.0	5.0	44	-12.6	-5.0	5.0
45	-20.7	-5.0	5.0	45	-14.6	-5.0	5.0
46	-22.9	-5.0	5.0	46	-16.7	-5.0	5.0
48	-27.3	-5.0	5.0	48	-21.1	-5.0	5.0
50	-32.1	-5.0	5.0	50	-25.8	-5.0	5.0
52	-37.1	-5.0	5.0	52	-30.8	-5.0	5.0
54	-42.3	-5.0	5.0	54	-36.1	-5.0	5.0
55	-45.0	-5.0	5.0	55	-38.9	-5.0	5.0
56	-47.8	-5.0	5.0	56	-41.8	-5.0	5.0
58	-53.7	-5.0	5.0	58	-47.8	-5.0	5.0
60	-59.8	-5.0	5.0	60	-54.2	-5.0	5.0

Table 15. Low evaporator refrigerant temperature cutout (LRTC) and low water temperature cutout (LWTC) – methanol and propylene glycol

Methanol			Calcium Chloride			
Solution Freeze Point (°F)	Minimum Recommended LRTC (°F)	Minimum Recommended LWTC (°F)	Inhibitor Percentage (%)	Solution Freeze Point (°F)	Minimum Recommended LRTC (°F)	Minimum Recommended LWTC (°F)
32.0	28.6	35.0	0	32.0	28.6	35.0
29.0	25.6	32.0	2	30.3	26.9	33.3
26.4	23.0	29.4	4	28.7	25.3	31.7
25.1	21.7	28.1	5	27.8	24.4	30.8

Table 15. Low evaporator refrigerant temperature cutout (LRTC) and low water temperature cutout (LWTC) – methanol and propylene glycol (continued)

Methanol			Calcium Chloride			
Solution Freeze Point (°F)	Minimum Recommended LRTC (°F)	Minimum Recommended LWTC (°F)	Inhibitor Percentage (%)	Solution Freeze Point (°F)	Minimum Recommended LRTC (°F)	Minimum Recommended LWTC (°F)
23.9	20.5	26.9	6	26.9	23.5	29.9
21.5	18.1	24.5	8	24.8	21.4	27.8
19.1	15.7	22.1	10	22.2	18.8	25.2
16.7	13.3	19.7	12	19.2	15.8	22.2
14.4	11.0	17.4	14	15.5	12.1	18.5
13.1	9.7	16.1	15	13.4	10.0	16.4
11.9	8.5	14.9	16	11.1	7.7	14.1
9.4	6.0	12.4	18	5.8	2.4	8.8
6.8	3.4	9.8	20	-0.4	-3.8	5.0
4.1	0.7	7.1	22	-7.7	-5.0	5.0
1.2	-2.2	5.0	24	-16.2	-5.0	5.0
-0.3	-3.7	5.0	25	-20.9	-5.0	5.0
-1.9	-5.0	5.0	26	-26.0	-5.0	5.0
-3.6	-5.0	5.0	27	-31.4	-5.0	5.0
-5.2	-5.0	5.0	28	-37.2	-5.0	5.0
-7.0	-5.0	5.0	29	-43.4	-5.0	5.0
-8.8	-5.0	5.0	30	-50.0	-5.0	5.0
-12.7	-5.0	5.0	—	—	—	—
-16.9	-5.0	5.0	—	—	—	—
-19.1	-5.0	5.0	—	—	—	—
-21.4	-5.0	5.0	—	—	—	—
-26.3	-5.0	5.0	—	—	—	—
-31.6	-5.0	5.0	—	—	—	—
-37.3	-5.0	5.0	—	—	—	—
-43.5	-5.0	5.0	—	—	—	—
-46.8	-5.0	5.0	—	—	—	—
-50.2	-5.0	5.0	—	—	—	—
-57.4	-5.0	5.0	—	—	—	—
-65.2	-5.0	5.0	—	—	—	—

Condenser Water Piping

Condenser water inlet and outlet types, sizes and locations are given in Unit Dimensions and Weights. Condenser pressure drops are shown in “[Pressure Drop Curves](#),” p. 35.

Condenser Piping Components

Condenser piping components and layout vary, depending on location of connections and water source.

Condenser piping components generally function identically to those in the evaporator piping system, as described in “[Evaporator Water Piping](#),” p. 32. In addition,

cooling tower systems should include a manual or automatic bypass valve that can alter the water flow rate, to maintain condensing pressure. Well water (or city water) condensing systems should include a pressure reducing valve and a water regulating valve.

Pressure reducing valve should be installed to reduce water pressure entering the condenser. This is required only if the water pressure exceeds 150 psig. This is necessary to prevent damage to the disc and seat of the water regulating valve that can be caused by excessive pressure drop through the valve and also due to the design of the condenser. Condenser waterside is rated at 150 psi.



NOTICE

Equipment Damage!

Do not exceed 150 psig condenser water pressure as it could result in damage to the condenser or regulating valve.

Water Regulating Valve

The Condenser Head Pressure Control Option provides for a 0 to 10V (maximum range - a smaller range is adjustable) output interface to the customer's condenser water flow device. See Condenser Water Temperature Control Water-Cooled Series R® Chillers Model RTWD Engineering Bulletin (RLC-PRB021*-EN) for further details regarding condenser water temperature control.

The following guidelines must be met for adequate oil circulation throughout the system.

- The RTWD requires a minimum pressure differential of 25 psid (172.1 kPa) at all load conditions in order to ensure adequate oil circulation.
- The entering condenser water temperature must be above 55°F (12.8°C), or between 45°F (7.2°C) and 55°F (12.8°C) with a 1°F (0.6°C) temperature rise per minute up to 55°F (12.8°C).
- The leaving condenser water temperature must be 17°F (9.4°C) degrees higher than leaving evaporator water temperature within 2 minutes of start-up. A 25°F (13.9°C) temperature differential must be maintained thereafter. (This differential requirement is lessened by 0.25°F [0.14°C] for every 1°F [0.6°C] that the leaving condenser water temperature is above 55°F [12.8°C].)

If the above guidelines cannot be met, then some form of condenser water temperature control must be used.

Notes:

- *Plugged tees are installed to provide access for chemical cleaning of the condenser tubes.*
- *Condenser piping must be in accordance with all applicable local and national codes.*

Condenser Drains and Vents

NOTICE

Waterbox Damage!

Failure to follow instructions could result in damage to the waterbox.

Do not over-tighten or use excessive Teflon® pipe tape when installing valves, drains, plugs and vents on waterboxes.

When the unit is shipped, the drain plugs are removed from the condenser and placed in a plastic bag in the control panel, along with the evaporator drain plug. The condenser drains may be connected to suitable drains to permit drainage during unit servicing. If they are not, the drain plugs must be installed prior to water pump operation.

The condenser shells can be drained by removing the drain plugs from the bottom of the condenser heads. Remove the vent plugs at the top of the condenser heads to facilitate complete drainage.

Water Treatment

NOTICE

Proper Water Treatment Required!

The use of untreated or improperly treated water could result in scaling, erosion, corrosion, algae or slime.

Use the services of a qualified water treatment specialist to determine what water treatment, if any, is required. Trane assumes no responsibility for equipment failures which result from untreated or improperly treated water, or saline or brackish water.

Water Pressure Gauges

Install field-supplied pressure gauges (with manifolds, when practical) on the units. Locate pressure gauges or taps in a straight run of pipe, avoid placement near elbows, and install gauges at the same elevation.

To read manifolded pressure gauges, open one valve and close the other (depending on the desired reading). This eliminates errors resulting from differently calibrated gauges installed at unmatched elevations.

Water Pressure Release Valves

Install a water pressure relief valve in the condenser and evaporator leaving chilled water piping. Water vessels with close coupled shutoff valves have a high potential for hydrostatic pressure buildup on a water temperature increase. Refer to applicable codes for relief valve installation guidelines.

Refrigerant Relief Valve Venting

⚠ WARNING

Refrigerant under High Pressure!

Failure to follow instructions below could result in an explosion which could result in death or serious injury or equipment damage.

System contains oil and refrigerant under high pressure. Recover refrigerant to relieve pressure before opening the system. See unit nameplate for refrigerant type. Do not use non-approved refrigerants, refrigerant substitutes, or refrigerant additives.

NOTICE**Equipment Damage!**

To prevent shell damage, install pressure relief valves in both the evaporator and condenser water systems.

NOTICE**Equipment Damage!**

Failure to comply with specifications may result in capacity reduction, unit damage and/or relief valve damage.

Do NOT exceed vent piping code specifications!

High Pressure Side Relief Valve Venting (RTWD-Condenser)

All units utilize a refrigerant-pressure relief valve for each circuit which must be vented to the outdoor atmosphere. The valves are located at the top of the condenser. Relief valve connections are 5/8 inch MFL. Refer to local codes for relief valve vent line sizing requirements.

High side relief valve discharge setpoint is 300 psig. Once the relief valve is opened, it will re-close when pressure is reduced to a safe level.

Note: Vent line length must not exceed code recommendations. If the line length will exceed code recommendations for the outlet size of the valve, install a vent line of the next larger pipe size.

Pipe each relief valve on the unit into a common vent line. Provide access valve located at the low point of the vent piping, to enable draining of any condensate that may accumulate in the piping.

If multiple chillers are installed, each unit may have separate venting for its relief valves. If multiple relief valves are vented together, see ASHRAE 15, and/or local codes for sizing requirements.

Note: RTWD units can be ordered with **Dual Relief Valve** options. Model number digit 16 is a 2. Units with this option will have two valves on each circuit for a total of four on the condenser. Only two valves would release at the same time - never all four.

Low Pressure Side Relief Valve Venting (Evaporator)

Low-side refrigerant-pressure relief valves are located on the top of the evaporator shell, one per circuit. Each must be vented to the outdoor atmosphere. Relief valve connections are 3/4 inch NPTFI.

Note: Units can be ordered with **Dual Relief Valve** option. Model number digit 16 is a 2. Units with this option will have two valves on each circuit for a total of four on the evaporator. Only two valves would release at the same time.

See and [Table 16, p. 46](#). Refer to local codes for relief valve vent line sizing requirements.

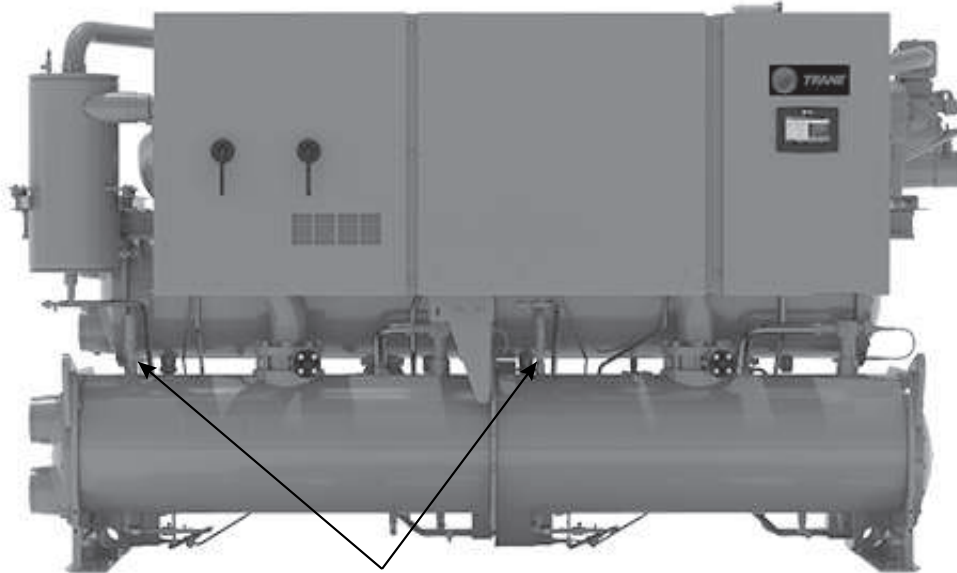
Figure 24. Evaporator relief valves

Evaporator Relief Valves

Note: Vent line length must not exceed code recommendations. If the line length will exceed code recommendations for the outlet size of the valve, install a vent line of the next larger pipe size.

Low side relief valve discharge setpoints are 200 psig. Once the relief valve has opened, it will re-close when pressure is reduced to a safe level.

Pipe each relief valve on the unit into a common vent line. Provide an access valve located at the low point of the vent piping, to enable draining of any condensate that may accumulate in the piping.

Summary of Relief Valves

Table 16. Relief valve descriptions

	Condenser	Evaporator
Units	High Pressure Side	Low Pressure Side
Relief Setpoint	300 psig	200 psig
Quantity (standard)	1 per ckt	1 per ckt
Quantity (Dual Relief Valves option)	2 per ckt	2 per ckt
Relief Rate (lb/min)	25.4	28.9
Filed Connection Size	5/8 in. MFL	3/4 in. NPTFI



Installation - Electrical

General Recommendations

As you review this manual, keep in mind that:

- All field-installed wiring must conform to National Electric Code (NEC) guidelines, and any applicable state and local codes. Be sure to satisfy proper equipment grounding requirements per NEC.
- Compressor motor and unit electrical data (including motor kW, voltage utilization range, rated load amps) is listed on the chiller nameplate.
- All field-installed wiring must be checked for proper terminations, and for possible shorts or grounds.

Note: Always refer to wiring diagrams shipped with chiller or unit submittal for specific electrical schematic and connection information.

⚠ WARNING

Hazardous Voltage!

Failure to disconnect power before servicing could result in death or serious injury.

Disconnect all electric power, including remote disconnects before servicing. Follow proper lockout/tagout procedures to ensure the power can not be inadvertently energized. Verify that no power is present with a voltmeter.

⚠ WARNING

Proper Field Wiring and Grounding Required!

Failure to follow code could result in death or serious injury.

All field wiring **MUST** be performed by qualified personnel. Improperly installed and grounded field wiring poses **FIRE** and **ELECTROCUTION** hazards. To avoid these hazards, you **MUST** follow requirements for field wiring installation and grounding as described in NEC and your local/state/national electrical codes.

NOTICE

Use Copper Conductors Only!

Failure to use copper conductors could result in equipment damage as the equipment was not designed or qualified to accept other types of conductors.

Important: Do not allow conduit to interfere with other components, structural members, or equipment. Control voltage (115V) wiring in conduit must be separate from conduit carrying low voltage (<30V) wiring. To prevent control malfunctions, do not run low voltage wiring (<30V) in conduit with conductors carrying more than 30 volts.

Installer-Supplied Components

Customer wiring interface connections are shown in the electrical schematics and connection diagrams that are shipped with the unit. The installer must provide the following components if not ordered with the unit:

- Power supply wiring (in conduit) for all field-wired connections.
- All control (interconnecting) wiring (in conduit) for field supplied devices.
- Fused-disconnect switches or circuit breakers.
- Power factor correction capacitors. See *Power Factor Correction Engineering Bulletin* (RLC-PRB023*-EN).

Power Supply Wiring

⚠ WARNING

Hazardous Voltage!

Failure to disconnect power before servicing could result in death or serious injury.

Disconnect all electric power, including remote disconnects before servicing. Follow proper lockout/tagout procedures to ensure the power can not be inadvertently energized. Verify that no power is present with a voltmeter.

⚠ WARNING

Hazardous Voltage!

Failure to disconnect power before servicing could result in death or serious injury.

Disconnect all electric power, including remote disconnects before servicing. Follow proper lockout/tagout procedures to ensure the power can not be inadvertently energized. Verify that no power is present with a voltmeter.

All power supply wiring must be sized and selected accordingly by the project engineer in accordance with NEC Table 310.15(B)(16); formerly Table 310-16.

All wiring must comply with local codes and the National Electrical Code. The installing (or electrical) contractor must provide and install the system interconnecting wiring, as well as the power supply wiring. It must be properly sized and equipped with the appropriate fused disconnect switches.

The type and installation location(s) of the fused disconnects must comply with all applicable codes.

Knock-outs for wiring are located on the upper left side of the control panel. The wiring is passed through these conduits and connected to the terminal blocks, optional unit-mounted disconnects, or HACR type breakers. Refer to the following figure.

To provide proper phasing of 3-phase input, make connections as shown in field wiring diagrams and as stated on the WARNING label on the starter panel. For additional information on proper phasing, refer to **Unit Voltage Phasing**. Proper equipment ground must be provided to each ground connection in the panel (one for each customer-supplied conductor per phase). 115 volt field-provided connections (either control or power) are made through knockouts on the right side of the panel. See the following figure. Additional grounds may be required for each 115 volt power supply to the unit. A terminal strip is provided for 115V customer wiring.

Figure 25. Power entrance

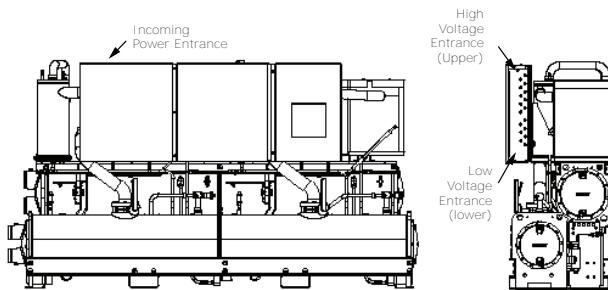

Control Power Supply

The unit is equipped with a control power transformer. Additional control power voltage to the unit is not necessary. No other loads should be connected to the control power transformer.

All units are factory-connected for appropriate labeled voltages.

Interconnecting Wiring

Chilled Water Flow (Pump) Interlock

If factory installed flow switch option is not selected, RTWD Series R[®] chillers require a field-supplied control voltage contact input through a flow proving switch 5S5 and an auxiliary contact 5K9 AUX. Connect the proving switch and auxiliary contact to 1A15 J3-1 and 1X4-1. Refer to the field wiring for details. The auxiliary contact can be BAS signal, starter contactor auxiliary, or any signal which indicates the pump is running. A flow switch is still required and cannot be omitted.

Condenser Water Flow Interlock

If factory installed flow switch option is not selected, RTWD Series R[®] chillers require a field-supplied control voltage contact input through a flow proving switch 5S6 and an auxiliary contact 5K10 AUX. Connect the proving switch and auxiliary contact to 1A15 J2-1 and 1X4-1. Refer to the field wiring for details. The auxiliary contact can be BAS signal, starter contactor auxiliary, or any signal which indicates the pump is running. A flow switch is still required and cannot be omitted.

Chilled Water Pump Control

If factory installed flow switch option is not selected, RTWD Series R[®] chillers require a field-supplied control voltage contact input through a flow proving switch 5S6 and an auxiliary contact 5K10 AUX. Connect the proving switch and auxiliary contact to 1A15 J2-1 and 1X4-1. Refer to the field wiring for details. The auxiliary contact can be BAS signal, starter contactor auxiliary, or any signal which indicates the pump is running. A flow switch is still required and cannot be omitted.

The relay output from board 1A14 is required to operate the Evaporator Water Pump (EWP) contactor. Contacts should be compatible with 115/240 Vac control circuit. The EWP relay operates in different modes depending on chiller control or Tracer commands, if available, or service pumpdown. (See maintenance section). Normally, the EWP relay follows the AUTO mode of the chiller. Whenever the chiller has no diagnostics and is in the AUTO mode, regardless of where the auto command is coming from, the normally open relay is energized. When the chiller exits the AUTO mode, the relay is timed open for an adjustable (using Tracer[®] TU) 0 to 30 minutes. The non-AUTO modes in which the pump is stopped, include Reset, Stop, External Stop, Remote Display Stop, Stopped by Tracer, Low Ambient Run Inhibit, and Ice Building complete. Regardless of whether the chiller is allowed to control the pump on a full-time basis, if the MP calls for a pump to start and water does not flow, the evaporator may be damaged catastrophically. It is the responsibility of the installing contractor and/or the customer to confirm that a pump will start when called upon by the chiller controls.

Table 17. Pump relay operation

Chiller Mode	Relay Operation
Auto	Instant close
Ice Building	Instant close
Tracer Override	Close
Stop	Timed Open
Ice Complete	Instant Open
Diagnostics	Instant Open

Note: Exceptions are listed below.

When going from Stop to Auto, the EWP relay is energized immediately. If evaporator water flow is not established in 4 minutes and 15 sec., the chiller control de-energizes the EWP relay and generates a non-latching diagnostic. If flow returns (e.g. someone else is controlling the pump), the diagnostic is cleared, the EWP is re-energized, and normal control resumed.

If evaporator water flow is lost once it had been established, the EWP relay remains energized and a nonlatching diagnostic is generated. If flow returns, the diagnostic is cleared and the chiller returns to normal operation.

In general, when there is either a non-latching or latching diagnostic, the EWP relay is turned off as though there was a zero time delay. Exceptions (see Table 60) whereby the relay continues to be energized occur with:

A Low Chilled Water Temp. diagnostic (non-latching) (unless also accompanied by an Evap Leaving Water Temperature Sensor Diagnostic)

OR

A starter contactor interrupt failure diagnostic, in which a compressor continues to draw current even after commanded to have shutdown

OR

A Loss of Evaporator Water Flow diagnostic (non-latching) and the unit is in the AUTO mode, after initially having proven evaporator water flow.

Alarm and Status Relay Outputs (Programmable Relays)

A programmable relay concept provides for enunciation of certain events or states of the chiller, selected from a list of likely needs, while only using four physical output relays, as shown in the field wiring diagram. The four relays are provided (generally with a Quad Relay Output LLID) as part of the Alarm Relay Output Option. The relay's contacts are isolated Form C (SPDT), suitable for use with 120 Vac circuits drawing up to 2.8 amps inductive, 7.2 amps resistive, or 1/3 HP and for 240 Vac circuits drawing up to 0.5 amp resistive. The list of events/states that can be assigned to the programmable relays can be found in the following table. The relay will be energized when the event/state occurs.

Table 18. Alarm and status relay output configuration

Alarm	Description
Latching Alarm	This output is true whenever there is any active latching shutdown diagnostic that targets the Unit, Circuit, or any of the Compressors on a circuit.
Non-latching Alarm	This output is true whenever there is any active non-latching shutdown diagnostic that targets the Unit, Circuit, or any of the Compressors on a circuit.
Alarm	This output is true whenever there is any active latching or non-latching shutdown diagnostic that targets the Unit, Circuit, or any of the Compressors on a circuit.
Alarm Circuit 1	This output is true whenever there is any active latching or non-latching shutdown diagnostic that targets Circuit 1, or any of the Compressors on Circuit 1.
Alarm Circuit 2	This output is true whenever there is any active latching or non-latching shutdown diagnostic that targets Circuit 2, or any of the Compressors on Circuit 2.
Chiller Limit Mode	This output is true whenever a circuit on the chiller has been running in one of the limit modes continuously for the Limit Relay debounce time. A given limit or overlapping of different limits must be in effect continuously for the debounce time prior to the output becoming true. It will become false if no limits are present for the debounce time.
Compressor Running	The output is true whenever any compressor is running.
Circuit 1 Running	The output is true whenever any compressor of Circuit 1 is running.
Circuit 2 Running	The output is true whenever any compressor of Circuit 2 is running.
Warning	The output is true whenever there is any active warning diagnostic that is associated with the Unit, Circuit, or any of the compressors on a circuit.
Max Capacity	The output is true whenever the unit has reached maximum capacity continuously for the Max Capacity Relay debounce time. The output is false when the unit is not at maximum capacity continuously for the filter debounce time. See the Max Capacity Relay specification for more information.
Evaporator Freeze Avoidance Request	This relay output is energized any time either the Low Evaporator Water Temperature – Unit Off or the Low Evaporator Temperature Ckt x – Unit Off diagnostics are active. This relay is intended for use as an external interlock for a field engineered and provided solution to mitigate the freeze danger implied by these diagnostics. Generally, this would be used in cases where operation of the evaporator water pump is unacceptable due to the system constraints, (i.e. such as mixing unconditioned warm water with controlled supply water as provided by other parallel chillers. The relay's output can provide the method to close bypass valves so the circulation becomes local to the evap and excludes the load, or can be used to defeat the evap pump override entirely while initiating an independent source of heat / flow to the evap.
Service Request	This relay will be energized when at least one Maintenance alert condition (refer to Service required message specification) occurs, as long as at least one of associated informational diagnostic(s) will be active.
Ice Making Status	This output is true when Ice Building status is active.
Condenser Freeze Avoidance Request	The Condenser Freeze Avoidance Request Relay will indicate when the condenser water pump is being commanded on in an override mode – this relay can provide therefore, the means of wiring additional pump, bypass valves, or to defeat the Condenser Pump Override, so as to still provide the necessary heat flow into the condenser to avoid a freeze.
Alarm – General Latching Unit	This output is true whenever there is latching alarm(s) that targets chiller or all circuits or all the compressors on a circuit so that the unit is unable to produce any capacity. It means that it activates when there is latching alarm on Chiller or 'General Latching Circuit X' on every circuits.



Installation - Electrical

Table 18. Alarm and status relay output configuration (continued)

Alarm	Description
Alarm – General Non Latching Unit	This output is true whenever there is at least a non-latching alarm(s) that targets chiller or circuits or compressors on a circuit and there are latching or/and non-latching diagnostics that targets chiller, circuits or compressors so that the unit is unable to produce any capacity.
Alarm – General Latching Ckt1	This output is true whenever there is latching alarm(s) that targets Circuit 1 or all the compressors on Circuit 1 so that the Circuit 1 is unable to produce any capacity. It means that it activates when there is latching alarm on circuit or latching alarms on every compressors of circuit.
Alarm – General Non Latching Ckt1	This output is true whenever there is non-latching alarm(s) that targets Circuit 1 or the compressors on Circuit 1 so that the Circuit 1 is unable to produce any capacity.
Alarm – General Latching Ckt2	This output is true whenever there is latching alarm(s) that targets Circuit 2 or all the compressors on Circuit 2 so that the Circuit 2 is unable to produce any capacity. It means that it activates when there is latching alarm on circuit or latching alarms on every compressors of circuit.
Alarm – General Non Latching Ckt2	This output is true whenever there is non-latching alarm(s) that targets Circuit 2 or the compressors on Circuit 2 so that the Circuit 2 is unable to produce any capacity.
Head Pressure Relief Request	This relay output is energized anytime the chiller or a single circuit on the chiller is running in one of the following modes: Ice Making Mode, or Condenser Pressure Limit continuously for the duration specified by the Chiller Head Relief Relay Filter Time. The Chiller Head Relief Relay Filter Time is a service setpoint. The relay output is de-energized anytime the chiller exits all above modes continuously for the duration specified by the same Chiller Head Relief Relay Filter Time.

Relay Assignments

Tracer® TU service sool is used to install the Alarm and Status Relay Option package and assign any of the above list of events or status to each of the four relays provided with the option. The relays to be programmed are referred to by the relay's terminal numbers on the LLID board 1A13. The default assignments for the four available relays of the Alarm and Status Package Option are:

Table 19. Default assignments

Relay	Assignment
Relay 1 Terminals J2 - 1,2,3	Evaporator Water Freeze Avoidance Request
Relay 2 Terminals J2 - 4,5,6	Condenser Water Freeze Avoidance Request
Relay 3 Terminals J2 - 7,8,9	Compressor Running
Relay 4 Terminals J2 - 10,11,12	Latching Alarm

If any of the Alarm/Status relays are used:

- Provide electrical power (115 Vac) with fused-disconnect to the panel and wire through the appropriate relays/terminals on 1A13.
- Provide wiring (switched hot, neutral, and ground connections) to the remote annunciation devices. Do not use power from the chiller's control panel transformer to power these remote devices. Refer to the field diagrams which are shipped with the unit.

Low Voltage Wiring

⚠ WARNING

Proper Field Wiring and Grounding Required!

Failure to follow code could result in death or serious injury.

All field wiring MUST be performed by qualified personnel. Improperly installed and grounded field wiring poses FIRE and ELECTROCUTION hazards. To avoid these hazards, you MUST follow requirements for field wiring installation and grounding as described in NEC and your local/state/national electrical codes.

Important:

1. The remote devices described below require low voltage wiring. All wiring to and from these remote input devices to the Control Panel must be made with shielded, twisted pair conductors. Be sure to ground the shielding only at the panel.
2. To prevent control malfunctions, do not run low voltage wiring (<30 V) in conduit with conductors carrying more than 30 volts.

Emergency Stop

The unit controller provides auxiliary control for a customer-specified or customer-installed latching trip out. When this customer-furnished remote contact is provided, the chiller will run normally when the contact is closed. When the contact opens, the unit will trip on a latching diagnostic. This latched condition requires either a manual reset at the front of the control panel or a power cycle of the unit controller to clear.

Connect low voltage leads to Emergency Stop terminal strip locations on External Auto-Stop and Emergency Stop

Inputs LLID board. Refer to the field diagrams that are shipped with the unit.

Silver or gold-plated contacts are recommended. These customer-furnished contacts must be compatible with 24 VDC, 12 mA resistive load.

External Auto/Stop

If the unit requires the external Auto/Stop function, the installer must provide leads from the remote contacts to the External Auto-Stop terminals of the External Auto-Stop and Emergency Stop Inputs LLID board in on the control panel.

The chiller will run normally when the contacts are closed. When either contact opens, the compressor(s), if operating, will go to the RUN:UNLOAD operating mode and cycle off. Unit operation will be inhibited. Closure of the contacts will permit the unit to return to normal operation.

Field-supplied contacts for all low voltage connections must be compatible with dry circuit 24 VDC for a 12 mA resistive load. Refer to the field diagrams that are shipped with the unit.

Ice Building Option

The unit controller provides auxiliary control for a customer-specified or customer-installed contact closure for ice building if configured and enabled. This output is known as the Ice Building Status Relay. The normally open contact will be closed when ice building is in progress and open when ice building has been normally terminated either through Ice Termination setpoint being reached or removal of the Ice Building command. This output is for use with the ice storage system equipment or controls (provided by others) to signal the system changes required as the chiller mode changes from **ice building** to **ice complete**. When Ice Making Control contact is provided, the chiller runs normally when the contact is open.

The unit controller accepts either an isolated contact closure (External Ice Building command) or a Remote Communicated input (Tracer®) to initiate and command the Ice Building mode.

The unit controller also provides a **Front Panel Ice Termination Setpoint**, settable through Tracer® TU, and adjustable from 20 to 31°F (-6.7 to -0.5°C) in at least 1°F (1°C) increments.

Note: *When in the ice building mode, and the evaporator entering water temperature drops below the ice termination setpoint, the chiller terminates the ice building mode and changes to the ice building complete mode.*

NOTICE

Equipment Damage!

Failure to follow instructions could result in damage to system components.

Freeze inhibitor must be adequate for the leaving water temperature.

Tracer® TU must also be used to enable or disable Ice Machine Control. This setting does not prevent the Tracer® from commanding Ice Building mode.

On contact closure, the unit controller will initiate an ice building mode, in which the unit runs fully loaded at all times. Ice building is terminated either by opening the contact or based on the entering evaporator water temperature. The unit controller does not permit the ice building mode to be reentered until the unit has been switched out of ice building mode (open Ice Making Control contacts) and then switched back into ice building mode (close Ice Making Control contacts.)

In ice building, all limits (freeze avoidance, evaporator, condenser, current) will be ignored. All safeties will be enforced.

If, while in ice building mode, the unit gets down to the freeze state setting (water or refrigerant), the unit will shut down on a manually resettable diagnostic, just as in normal operation.

Connect leads from 5K36 to the proper terminals of 1K8. Refer to the field diagrams which are shipped with the unit.

Silver or gold-plated contacts are recommended. These customer-furnished contacts must be compatible with 24 VDC, 12 mA resistive load.

External Chilled or Hot Water Setpoint (ECWS/EHWS) Option

The unit controller provides inputs that accept either 4 to 20 mA or 2 to 10 VDC signals to set the external chilled water setpoint (ECWS) when in cooling mode, or external hot water setpoint (EHWS) when in heating mode. This is not a reset function. The input defines the setpoint. This input is primarily used with generic building automation systems (BAS). The chilled or hot water setpoint is set via the Tracer® AdaptiView™ TD-7 or through digital communication. The arbitration of the various water setpoint sources is described in the flow charts at the end of the section.

The chilled water setpoint may be changed from a remote location by sending either a 2 to 10 VDC or 4 to 20 mA signal to the External Demand Limit and Chilled Water Setpoint Inputs LLID board, terminals 5 and 6 LLID. 2 to 10 VDC and 4 to 20 mA each correspond to:

- ECWS: 10 to 68°F (-12.22 to 20°C)
- EHWS: 77 to 158°F (25 to 70°C)

Note: *The Active Hot Water Setpoint max shall not exceed 140°F for R-513A or 167°F for R-515B.*

The external chilled water setpoint (ECWS) and external hot water setpoint (EHWS) minimum and maximum values are configurable.



Installation - Electrical

Table 20. Default minimum and maximum values

External Water Setpoint	Default Temperature			
	Minimum		Maximum	
	°F	°C	°F	°C
Chilled (ECWS)	10	-12	68	20
Hot (EHWS)	77	25	158	70

The equations below apply if using default minimum and maximum values, as shown in table above.

Table 21. EWS equations - default minimum and maximum values

Chilled Water Setpoint	Voltage Signal	Current Signal
As generated from external source	$V_{dc} = 0.1379 * (ECWS) + 0.621$	$mA = 0.2759 * (ECWS) + 1.241$
As processed by unit controller	$ECWS = 7.25 * (V_{dc}) - 4.5$	$ECWS = 3.625 * (mA) - 4.5$
Hot Water Setpoint	Voltage Signal	Current Signal
As generated from external source	$V_{dc} = 0.0988 * (EHWS) - 5.6$	$mA = 0.1975 * (EHWS) - 11.2$
As processed by unit controller	$EHWS = 10.125 * (V_{dc}) + 56.75$	$EHWS = 5.0625 * (mA) + 56.75$

Temperatures are in units of °F.

If minimum and maximum values have been changed from default values, use the following equations:

Table 22. EWS equations - any minimum and maximum values

For Voltage Input Signal	$EWS = Min + (Max - Min) * (V_{dc} - 2) / 8$
For Current Input Signal	$EWS = Min + (Max - Min) * (mA - 4) / 16$

Temperatures are in units of °F.

If the input develops an open or short, the LLID will report either a very high or very low value back to the main processor. This will generate an informational warning and the unit will default to using the front Panel (TD-7) Chilled Water Setpoint.

Tracer® TU Service Tool is used to set the input signal type from the factory default of 2 to 10 Vdc to that of 4 to 20 mA. Tracer TU is also used to install or remove the External Chilled Water Setpoint option as well as a means to enable and disable ECWS.

External Demand Limit Setpoint (EDLS) Option

Similar to the above, the controller also provides an optional External Demand Limit Setpoint (EDLS) that will accept either a 2 to 10 Vdc (default) or a 4 to 20 mA signal. The demand limit can also be set via the operator display or through digital communication with Tracer® SC+ building

automation system or third party building automation system. The arbitration of the various sources of demand limit is described in the flow charts at the end of this section. The EDLS may be changed from a remote location by hooking up the analog input signal to the board 1A7, J2-2 and 3. Refer to the following paragraph on Analog Input Signal Wiring Details. The following equations apply for EDLS if using default minimum 40 percent and maximum 120 percent.

Voltage Signal	
As generated from external source	$VDC = 0.1 (\%) - 2.0$
As processed by the unit controller	$\% = 10 * (VDC) + 20$
Current Signal	
As generated from external source	$mA = 0.2 (\%) - 4.0$
As processed by the unit controller	$\% = 5 * (mA) + 20$

If the EDLS input develops an open or short, the LLID will report either a very high or very low value back to the main processor. This will generate an informational diagnostic and the unit will default to using the Front Panel Demand Limit Setpoint.

Tracer® TU must be used to set the input signal type from the factory default of 2 to 10 Vdc to that of 4 to 20 mA current. Tracer TU must be also be used to install or remove the External Demand Limit Setpoint Option for field installation, or can be used to enable or disable the feature (if installed).

EDLS and ECWS Analog Input Signal Wiring Details:

Both the ECWS and EDLS can be connected and setup as either a 2 to 10 Vdc (factory default), 4 to 20 mA, or resistance input (also a form of 4 to 20mA) as indicated below. Depending on the type to be used, Tracer TU must be used to configure the LLID and the controller for the proper input type that is being used. This is accomplished by a setting change on the Custom Tab of the Configuration View within Tracer TU.

The J2-3 and J2-6 terminal is chassis grounded and terminal J2-1 and J2-4 can be used to source 12 Vdc. The EDLS uses terminals J2-2 and J2-3. ECWS uses terminals J2-5 and J2-6. Both inputs are only compatible with high-side current sources.

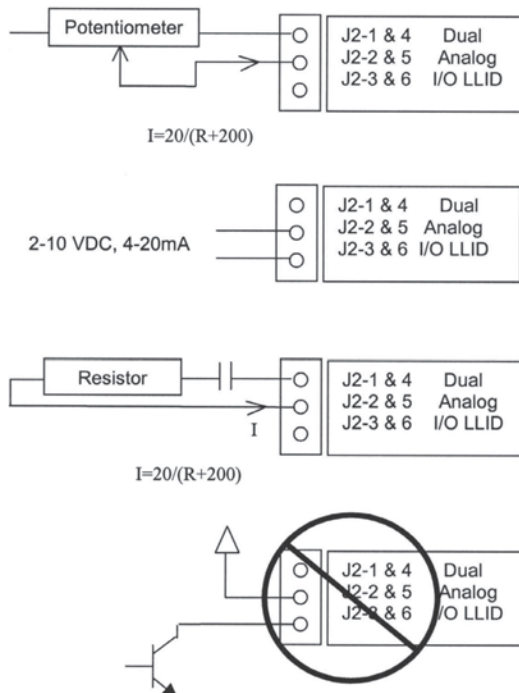
Figure 26. Wiring examples for EDLS and ECWS/EHWS

Chilled Water Reset (CWR)

The unit controller resets the chilled water temperature set point based on either return water temperature, or outdoor air temperature. Return Reset is standard, Outdoor Reset is optional.

The following shall be selectable:

- One of three Reset types: None, Return Water Temperature Reset, Outdoor Air Temperature Reset, or Constant Return Water Temperature Reset.
- Reset Ratio setpoints: For outdoor air temperature reset there shall be both positive and negative reset ratios.
- Start Reset Setpoints.
- Maximum Reset setpoints.

The equations for each type of reset are as follows:

Return

$$CWS' = CWS + \text{RATIO} (\text{START RESET} - (TWE - TWL))$$

$$\text{and } CWS' > \text{ or } = CWS$$

$$\text{and } CWS' - CWS < \text{ or } = \text{Maximum Reset}$$

Outdoor

$$CWS' = CWS + \text{RATIO} * (\text{START RESET} - \text{TOD})$$

$$\text{and } CWS' > \text{ or } = CWS$$

$$\text{and } CWS' - CWS < \text{ or } = \text{Maximum Reset}$$

where

- CWS' is the new chilled water set point or the **reset CWS**

- CWS is the active chilled water set point before any reset has occurred, e.g. normally Front Panel, Tracer®, or ECWS
- RESET RATIO is a user adjustable gain
- START RESET is a user adjustable reference
- TOD is the outdoor temperature
- TWE is entering evap. water temperature
- TWL is leaving evap. water temperature
- MAXIMUM RESET is a user adjustable limit providing the maximum amount of reset. For all types of reset, $CWS' - CWS < \text{ or } = \text{Maximum Reset}$.

Reset Type	Range Reset Ratio	Start Reset	Max Reset	Increment	Factory Default
Return	10 to 120%	4 to 30°F (2.2 to 16.7 °C)	0 to 20°F (0.0 to 11.1°C)	1%	50%
Outdoor	-80 to 80%	50 to 130°F (10 to 54.4°C)	0 to 20°F (0.0 to 11.1°C)	1%	10%

In addition to Return and Outdoor Reset, the MP provides a menu item for the operator to select a Constant Return Reset. Constant Return Reset will reset the leaving water temperature set point so as to provide a constant entering water temperature. The Constant Return Reset equation is the same as the Return Reset equation except on selection of Constant Return Reset, the MP will automatically set Ratio, Start Reset, and Maximum Reset to the following:

- RATIO = 100%
- START RESET = Design Delta Temp.
- MAXIMUM RESET = Design Delta Temp.

The equation for Constant Return is then as follows:

$$CWS' = CWS + 100\% (\text{Design Delta Temp.} - (TWE - TWL)) \text{ and } CWS' > \text{ or } = CWS$$

- and $CWS' - CWS < \text{ or } = \text{Maximum Reset}$

When any type of CWR is enabled, the MP will step the Active CWS toward the desired CWS' (based on the above equations and setup parameters) at a rate of 1 degree F every 5 minutes until the Active CWS equals the desired CWS'. This applies when the chiller is running.

When the chiller is not running, CWS is reset immediately (within one minute) for Return Reset and at a rate of 1 degree F every 5 minutes for Outdoor Reset. The chiller will start at the Differential to Start value above a fully reset CWS or CWS' for both Return and Outdoor Reset.

Outdoor Air Temperature Sensor Installation Requirements

The outdoor air temperature sensor is optional. The temperature sensor probe is shipped separately inside the control panel.



Installation - Electrical

The outdoor air sensor probe must be located and installed at a location to sense the ambient air temperature, while avoiding direct sunlight.

Important: Use only the probe provided, as it is calibrated at the factory for accuracy.

A twisted pair sheathed cable shall be run and connected between the outdoor temperature sensor and its LLID module in the chiller control panel. The sensor's circuit is a class II power limited analog circuit and therefore the wire should not be run in close proximity to any power or line voltage wiring. Splices must be watertight and the wire run should be physically supported at equal intervals with consideration for safety and reliability/durability with wire ties or similar to meet local codes.

Building Automation Systems

BACnet® Building Automation Control Network

The BACnet control network for Symbio™ 800 expands communications from the unit controls network to the Tracer® Ensemble™ or Tracer® SC+ building automation system (BAS) or third party building automation system. Utilizing BACnet, the BAS allows external setpoint and configuration adjustment and monitoring of status and diagnostics. The Symbio 800 utilizes the BACnet defined TP protocol as defined in ASHRAE standard 135-2004. This controller works in standalone mode, with Tracer

Ensemble, Tracer SC+ or when connected to a third party building automation system that supports BACnet.

Modbus® Automation Control Network

Allows the user to easily interface with Modbus RTU communication protocol via a single twisted pair wiring or Modbus TCP over Ethernet from the Symbio™ 800 controller to a factory installed device.

LonTalk® Building Automation Systems

The LonTalk communication protocol for the Symbio™ 800 controller expands communications from the unit controls network to a Tracer® Ensemble™ building automation system or third party building automation system. Utilizing LonTalk, the BAS allows external setpoint and configuration adjustment and monitoring of status and diagnostics. The Symbio 800 utilizes an FTT-10A free topology transceiver, which supports non-polarity sensitive, free topology wiring—which in turn allows the system installer to utilize star, bus, and loop architectures. This controller works in standalone mode, peer-to-peer with one or more other units, or when connected to a Tracer Ensemble, Tracer SC+, or a third party building automation system that supports LonTalk.

Note: An optional module is required for Symbio 800 support of LonTalk. See Tracer® USB LonTalk Module Installation Instructions (BAS-SVN138*-EN).



Operating Principles

This section contains an overview of the operation of Series R[®] chillers equipped with microcomputer-based control systems. It describes the overall operating principles.

Note: For proper diagnosis and repair, contact a qualified service organization if a problem should occur.

The units are dual-compressor, dual circuit, and water-cooled liquid chillers. These units are equipped with unit-mounted starter/control panels. The basic components of the unit are:

- Unit-mounted panel containing starter and Symbio™ 800 controller and Input/Output LLIDS
- Helical-rotary compressors
- Evaporator
- Condenser
- Electronic expansion valves
- Water-cooled condenser with integral subcooler
- Oil supply system
- Oil cooler (application dependent)
- Related interconnecting piping

⚠ WARNING

Refrigerant under High Pressure!

Failure to follow instructions below could result in an explosion which could result in death or serious injury or equipment damage.

System contains oil and refrigerant under high pressure. Recover refrigerant to relieve pressure before opening the system. See unit nameplate for refrigerant type. Do not use non-approved refrigerants, refrigerant substitutes, or refrigerant additives.

⚠ WARNING

Hazardous Voltage!

Failure to disconnect power before servicing could result in death or serious injury.

Disconnect all electric power, including remote disconnects before servicing. Follow proper lockout/tagout procedures to ensure the power can not be inadvertently energized. Verify that no power is present with a voltmeter.

Figure 27. RTWD components – front view

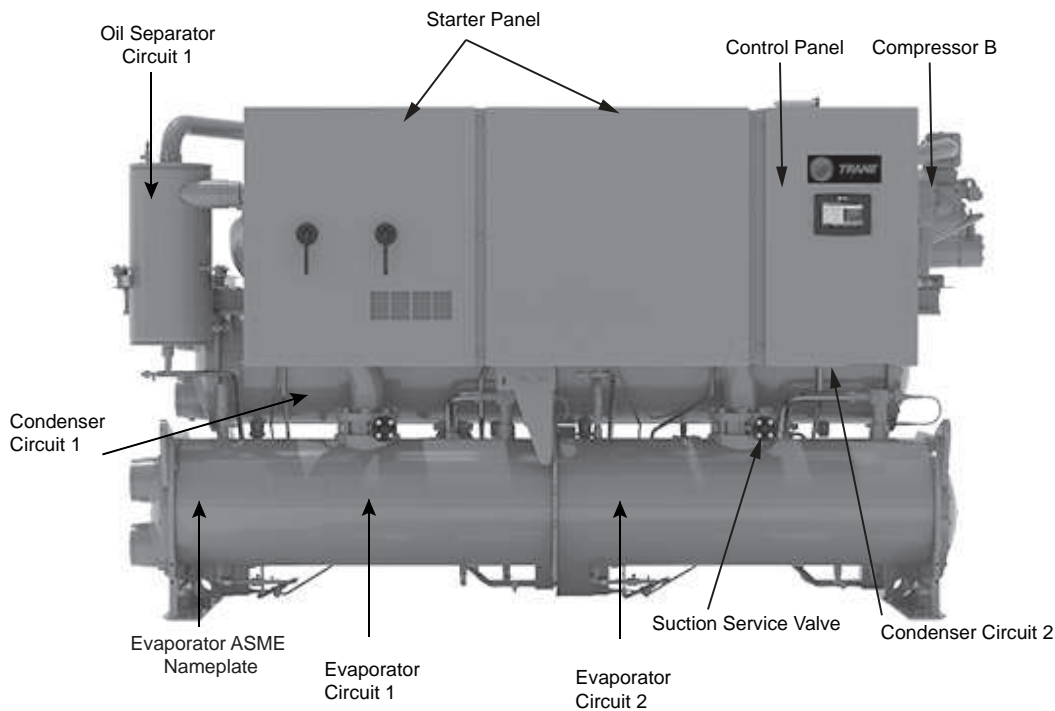
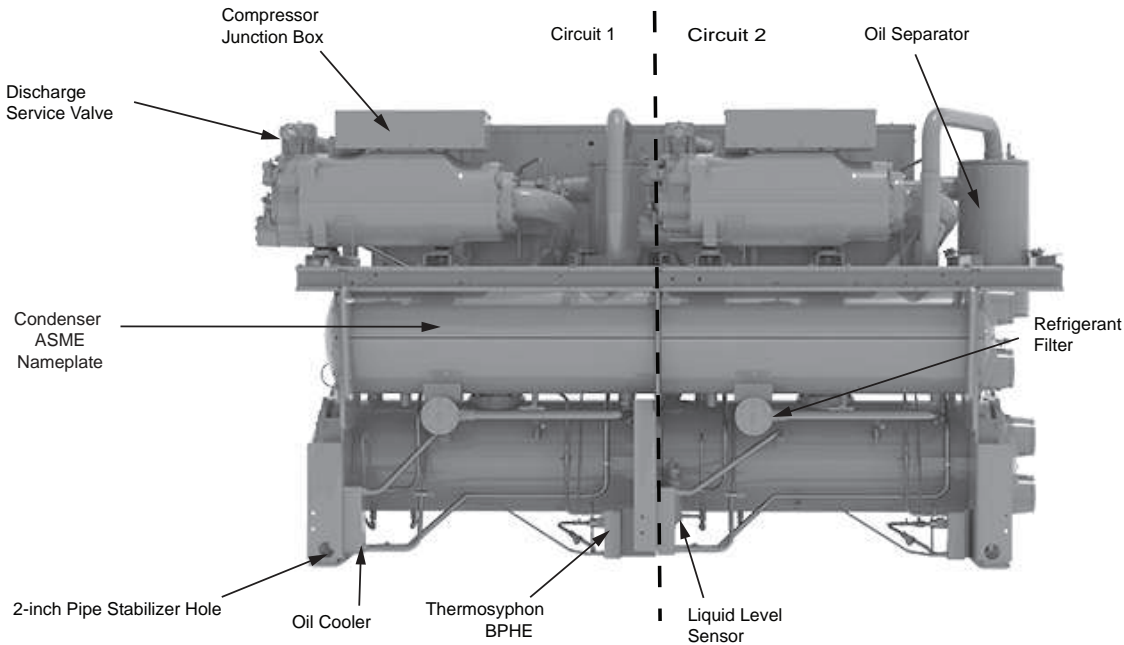

Figure 28. RTWD components – back view



Refrigeration (Cooling) Cycle

Overview

The refrigeration cycle of the Series R[®] chiller is conceptually similar to that of other Trane chiller products. It makes use of a shell-and-tube evaporator design with refrigerant evaporating on the shell side and water flowing inside tubes having enhanced surfaces.

The compressor is a twin-rotor helical rotary type. It uses a suction gas-cooled motor that operates at lower motor temperatures under continuous full and part load operating conditions. An oil management system provides an almost oil-free refrigerant to the shells to maximize heat transfer performance, while providing lubrication and rotor sealing to the compressor. The lubrication system confirms long compressor life and contributes to quiet operation.

Refrigerant is condensed in a shell-and-tube heat exchanger where refrigerant is condensed on the shell side and water flows internally in the tubes.

Refrigerant is metered through the flow system using an electronic expansion valve, that maximizes chiller efficiency at part load.

A unit-mounted starter and control panel is provided on every chiller. Microprocessor-based unit control modules provide for accurate chilled water control as well as monitoring, protection and adaptive limit functions. The **adaptive** nature of the controls intelligently prevents the chiller from operating outside of its limits, or compensates for unusual operating conditions, while keeping the chiller running rather than simply tripping due to a safety concern. When problems do occur, diagnostic messages assist the operator in troubleshooting.

Cycle Description

The refrigeration cycle for the RTWD chiller can be described using the pressure-enthalpy diagram shown below. Key State Points are indicated on the figure and are referenced in the discussion following.

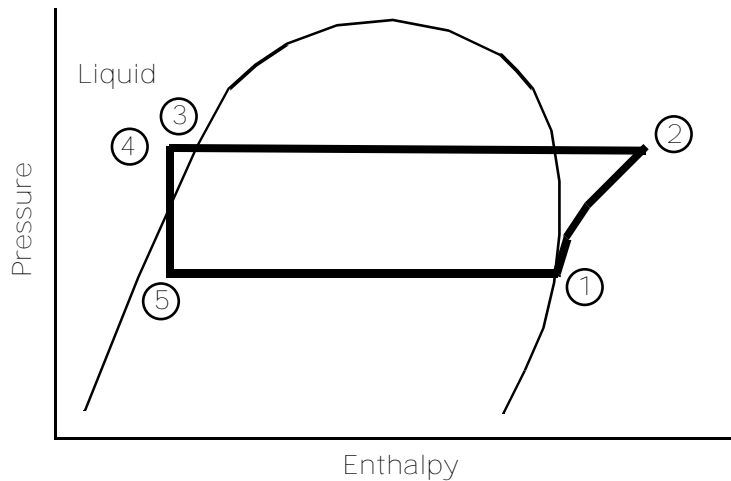
Figure 29. Pressure enthalpy curve

Evaporation of refrigerant occurs in the evaporator. A metered amount of refrigerant liquid enters a distribution system in the evaporator shell and is then distributed to the tubes in the evaporator tube bundle. The refrigerant absorbs heat and vaporizes as it cools the water flowing through the evaporator tubes. Refrigerant leaves the evaporator as saturated vapor (State Pt. 1).

The refrigerant vapor generated in the evaporator flows to the suction end of the compressor where it enters the motor compartment of the suction-gas-cooled motor. The refrigerant flows across the motor, providing the necessary cooling, then enters the compression chamber. Refrigerant is compressed in the compressor to discharge pressure conditions. Simultaneously, lubricant is injected into the compressor for two purposes: (1) to lubricate the rolling element bearings, and (2) to seal the very small clearances between the compressor's twin rotors. Immediately following the compression process the lubricant and refrigerant are effectively divided using an oil separator. The oil-free refrigerant vapor enters the condenser at State Pt. 2. The lubrication and oil management issues are discussed in more detail in the compressor description and oil management sections that follow.

A discharge baffle within the condenser shell distributes the compressed refrigerant vapor evenly across the condenser tube bundle. Cooling tower water, circulating through the condenser tubes, absorbs heat from this refrigerant and condenses it.

As the refrigerant enters the bottom of the condenser (State Pt. 3), it enters an integral subcooler where additional heat is removed before traveling to the electronic expansion valve (State Pt. 4). The pressure drop created by the expansion process vaporizes a portion of the liquid refrigerant. The resulting mixture of liquid and gaseous refrigerant then enters the Evaporator Distribution system

(State Pt. 5). The flash gas from the expansion process is internally routed to compressor suction, while the liquid refrigerant is distributed over the tube bundle in the evaporator.

The chiller maximizes the evaporator heat transfer performance while minimizing refrigerant charge requirements. This is accomplished by metering the liquid refrigerant flow to the evaporator's distribution system using the electronic expansion valve. A relatively low liquid level is maintained in the evaporator shell, which contains a bit of surplus refrigerant liquid and accumulated lubricant. A liquid level measurement device monitors this level and provides feedback information to the unit controller, which commands the electronic expansion valve to reposition when necessary. If the refrigerant level rises, the expansion valve is closed slightly, and if the level is dropping, the valve is opened slightly such that a steady level is maintained.

Compressor

A two-pole, hermetic, induction motor (3600 rpm at 60 hz, 3000 rpm at 50hz) directly drives the compressor rotors. The motor is cooled by suction refrigerant gas from the evaporator as it is routed back to the compressor rotors.

Oil Management

The unit is configured with an oil management system to confirm proper oil circulation throughout the unit. The key components of the system include an oil separator, oil filter, oil sump, and oil sump heater. An auxiliary oil cooler is installed when the chiller is purchased as a high condensing temperature or low evaporator temperature unit.



Controls

Symbio™ 800

The Symbio 800 controller is a factory-installed, application specific and programmable controller designed to control chillers and large packaged HVAC equipment. A 7 inch user interface features a touch-sensitive color screen that provides facility managers at-a-glance operating status, performance monitoring, scheduling changes, and operating adjustments. Other advanced features include automated controller back-up, and optional features such as secure remote connectivity, wireless building communications, mobile device connectivity, and custom programming with an expandable I/O.

For more information, see *Symbio™ 800 Controller Installation, Operation, and Maintenance* (BAS-SVX080*-EN).

AdaptiView™ Display

Information is tailored to operators, service technicians, and owners. When operating a chiller, specific information is needed on a day-to-day basis—setpoints, limits, diagnostic information, and reports. This information is provided through the AdaptiView display. Logically organized groups of information — chiller modes of operation, active diagnostics, settings and reports put information conveniently at your fingertips.

For more information, see *Water-Cooled Chiller Model RTWD AdaptiView™ Display with Symbio™ Controls User Guide* (RLC-SVU009*-EN).

Tracer® TU

The AdaptiView TD-7 operator interface allows for daily operational tasks and setpoint changes. However, to adequately service chillers, Tracer® TU service tool is required. (Non-Trane personnel, contact your local Trane office for software purchase information.) Tracer TU adds a level of sophistication that improves service technician effectiveness and minimizes chiller downtime. This portable PC-based service-tool software supports service and maintenance tasks, and is required for software upgrades, configuration changes and major service tasks.

Tracer TU serves as a common interface to all Trane chillers, and will customize itself based on the properties of the chiller with which it is communicating. Thus, the service technician learns only one service interface.

The panel bus is easy to troubleshoot using LED sensor verification. Only the defective device is replaced. Tracer TU can communicate with individual devices or groups of devices.

All chiller status, machine configuration settings, customizable limits, and up to 100 active or historic diagnostics are displayed through the service-tool software interface.

LEDs and their respective Tracer TU indicators visually confirm the availability of each connected sensor, relay, and actuator.

Tracer TU is designed to run on a customer's laptop, connected to the Symbio™ 800 control panel with a USB cable. See *Tracer® TU Service Tool User Guide* (BAS-SVU046*-EN) for laptop requirements.

Notes:

- *Tracer TU is designed and validated for this minimum laptop configuration. Any variation from this configuration may have different results. Therefore, support for Tracer TU is limited to only those laptops with the configuration previously specified.*
- *For more information, see *Tracer® TU Service Tool User Guide* (BAS-SVU046*-EN).*

Figure 30. Tracer TU

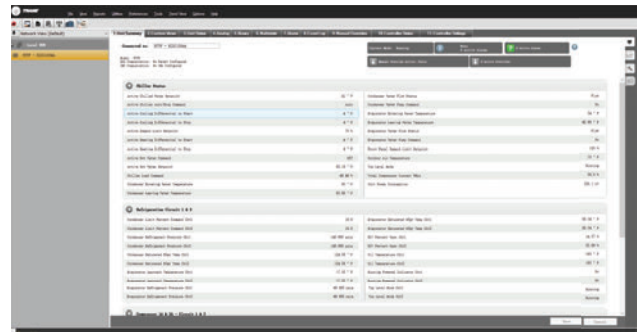



Pre-Start

Upon completion of installation, complete the Installation Completion Check Sheet and Request for Trane Service checklist in [“Log and Check Sheets,” p. 93.](#)

Important: *Start-up must be performed by Trane or an agent of Trane specifically authorized to perform start-up and warranty of Trane products. Contractor shall provide Trane (or an agent of Trane specifically authorized to perform start-up) with notice of the scheduled start-up at least two weeks prior to the scheduled start-up.*



Start-Up and Shutdown

Important: Initial unit commissioning start-up must be performed by Trane or an agent of Trane specifically authorized to perform start-up and warranty of Trane products. Contractor shall provide Trane (or an agent of Trane specifically authorized to perform start-up) with notice of the scheduled start-up at least two weeks prior to the scheduled start-up.

Unit Start-Up

NOTICE

Equipment Damage!

Failure to follow instructions could result in equipment damage.

Ensure that the compressor and oil sump heaters have been operating properly for a minimum of 24 hours before starting.

If required, once the system has been operating for approximately 30 minutes and has become stabilized, complete the remaining start-up procedures, as follows:

1. Check the evaporator refrigerant pressure and the condenser refrigerant pressure under Subcomponent Report on the AdaptiView™ TD-7 or Tracer® TU. The pressures are referenced to sea level (14.6960 psia).
2. Check the EXV sight glasses after sufficient time has elapsed to stabilize the chiller. The refrigerant flow past the sight glasses should be clear. Bubbles in the refrigerant indicate either low refrigerant charge or excessive pressure drop in the liquid line or a stuck open expansion valve. A restriction in the line can sometimes be identified by a noticeable temperature differential between the two sides of the restriction. Frost will often form on the line at this point. Proper refrigerant charges are shown in the General Information Section.

Important: A clear sight glass alone does not mean that the system is properly charged. Also check system subcooling, liquid level control and unit operating pressures.

If chiller is limited by any limiting conditions, contact local Trane service organization for more information.

Temporary Shutdown and Restart

To shut the unit down for a short time:

- Press the STOP key on the AdaptiView™ TD-7. The compressors will continue to operate and an operational pump down cycle may be initiated.
- Symbio™ 800 pump control will turn off the pump (after a minimum 1 min. delay) when the STOP key is pressed and automatically restart the pump when the

unit starts normally.

To restart the unit after a temporary shutdown, enable the chilled-water pump and press the AUTO key. The unit will start normally, provided the following conditions exist:

- The Symbio™ 800 receives a call for cooling and the differential-to-start is above the setpoint.
- All system operating interlocks and safety circuits are satisfied.

Extended Unit Shutdown

1. Perform the normal unit stop sequence using the Stop button on the TD-7 Touchscreen.

Note: Do not open starter disconnect switch. This must remain closed to provide control power from the control power transformer to the oil sump heater.

2. Verify chilled water and condenser water pumps are cycled off. If needed, open disconnect switches to the pumps.
3. Drain condenser piping and cooling tower, if needed.
4. Remove the drain and vent plugs from the condenser headers to drain the condenser.
5. Verify that the crank case heater is working.
6. Once the unit is secured, perform the maintenance identified in the following sections.

Seasonal Unit Start-Up Procedure

1. Close all valves and re-install the drain plugs in the evaporator and condenser heads.
2. Service the auxiliary equipment according to the start-up/ maintenance instructions provided by the respective equipment manufacturers.
3. Vent and fill the cooling tower, if used, as well as the condenser and piping. At this point, all air must be removed from the system (including each pass). Close the vents in the evaporator chilled water circuits.
4. Open all valves in the evaporator chilled water circuits.
5. If the evaporator was previously drained, vent and fill the evaporator and chilled water circuit. When all air is removed from the system (including each pass), install the vent plugs in the evaporator water boxes.

NOTICE

Equipment Damage!

Failure to follow instructions could result in equipment damage.

Ensure that the compressor and oil sump heaters have been operating properly for a minimum of 24 hours before starting.

6. Check the adjustment and operation of each safety and operating control.
7. Close all disconnect switches.
8. Refer to the sequence for daily unit start-up for the remainder of the seasonal start-up.

Sequence of Operation

This section provides basic information on chiller operation for common events. Adaptive control algorithms are used on these chillers. This section illustrates common control sequences.

Software Operation Overview

The following figure is a diagram of the five possible software states. This diagram can be thought of as a state chart, with the arrows and arrow text, depicting the transitions between states:

- The text in the circles is the internal software designations for each state.
- The shading of each software state circle corresponds to the shading on the time lines that show the chiller's state.

There are five generic states that the software can be in:

- Power Up
- Stopped
- Starting
- Running
- Stopping

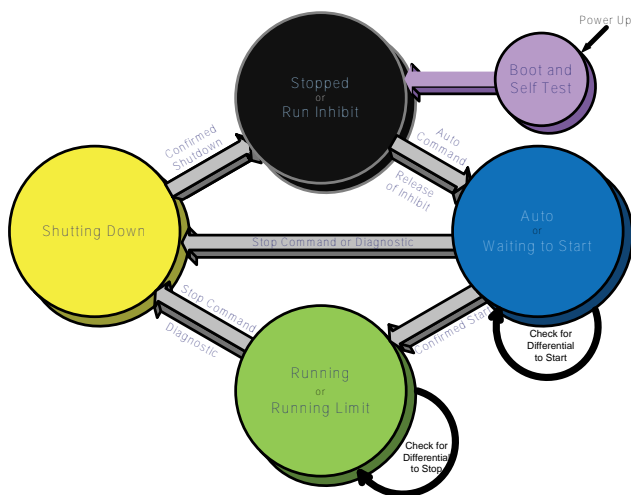

In the following diagrams:

- The time line indicates the upper level operating mode, as it would be viewed in the Tracer[®] AdaptiView[™].
- The shading color of the cylinder indicates the software state.
- Text in parentheses indicates sub-mode text as viewed in the Tracer AdaptiView.
- Text above the time line cylinder is used to illustrate inputs to the Symbio[™] 800. This may include user input to the Tracer AdaptiView touch screen, control inputs from sensors, or control inputs from a generic BAS.
- Boxes indicate control actions such as turning on relays, or pulsing compressor load or unload solenoids.
- Smaller cylinders under the main cylinder indicate diagnostic checks.
- Text outside a box or cylinder indicates time-based functions.
- Solid double arrows indicate fixed timers.
- Dashed double arrows indicate variable timers.

Power Up Diagram

The following diagram shows the respective TD-7 AdaptiView[™] screens during a power up of the Symbio[™] 800 and display. This process takes 15 seconds for the Symbio 800 and 105 seconds for the display. On all power ups, the software model always will transition through the 'Stopped' Software state independent of the last mode. If the last mode before power down was 'Auto', the transition from 'Stopped' to 'Starting' occurs, but it is not apparent to the user.

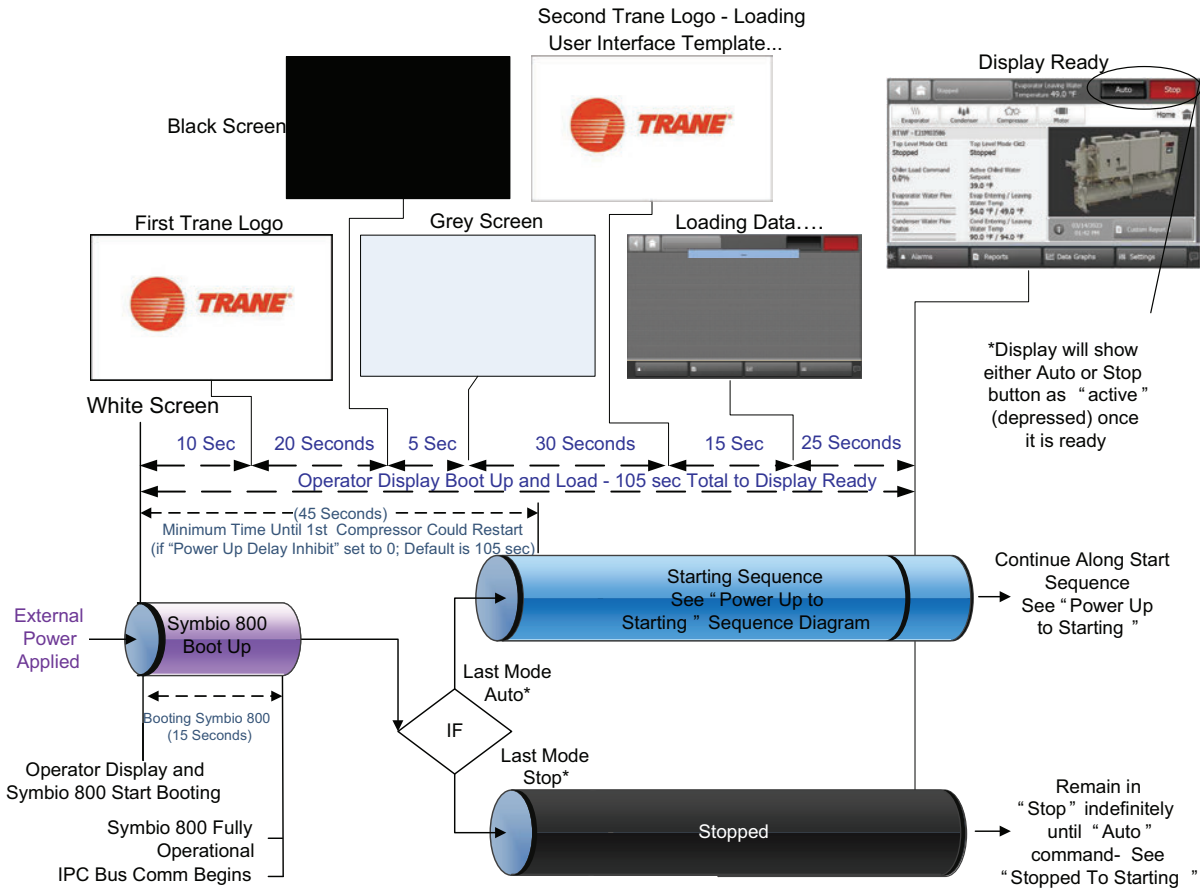

Power Up to Starting

The following diagram shows the timing from a power up event to energizing the first compressor. The shortest allowable time would be under the following conditions:

- No motor restart inhibit
- Evaporator water flowing
- Condenser water flowing
- Power up Start Delay set to 0 minutes

- Condenser Water Pump Pre-run time set to 0 minutes.
- No Condenser Head Pressure Control (stroke time delays)
- Need to cool (differential to start) already exists

The above conditions would allow for a minimum power up to starting the first compressor time of about 95 seconds

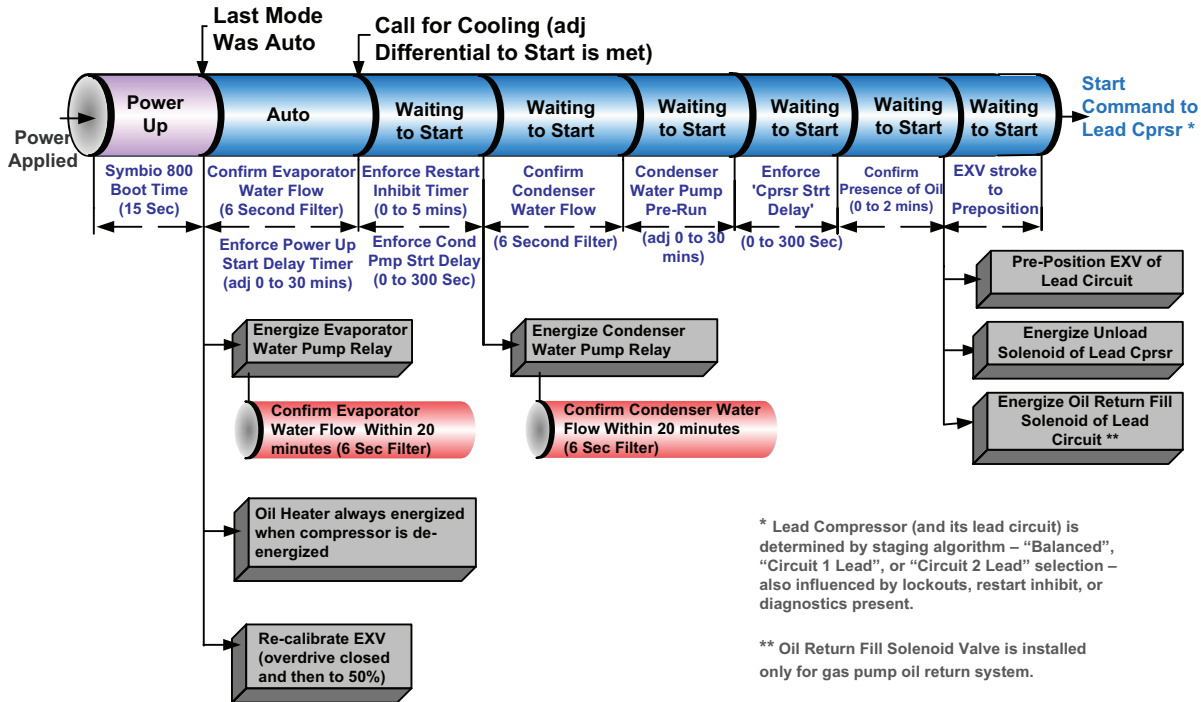

- Condenser Water Pump Pre-run time set to 0 minutes.
- No Condenser Head Pressure Control (stroke time delays)
- Need to cool (differential to start) already exists

The above conditions would allow a compressor to start in about 60 seconds.

Stopped to Starting

The following diagram shows the timing from a stopped mode to energizing the first compressor. The shortest allowable time would be under the following conditions:

- No motor restart inhibit time
- Evaporator and condenser water flowing
- Power up Start Delay Timer has expired

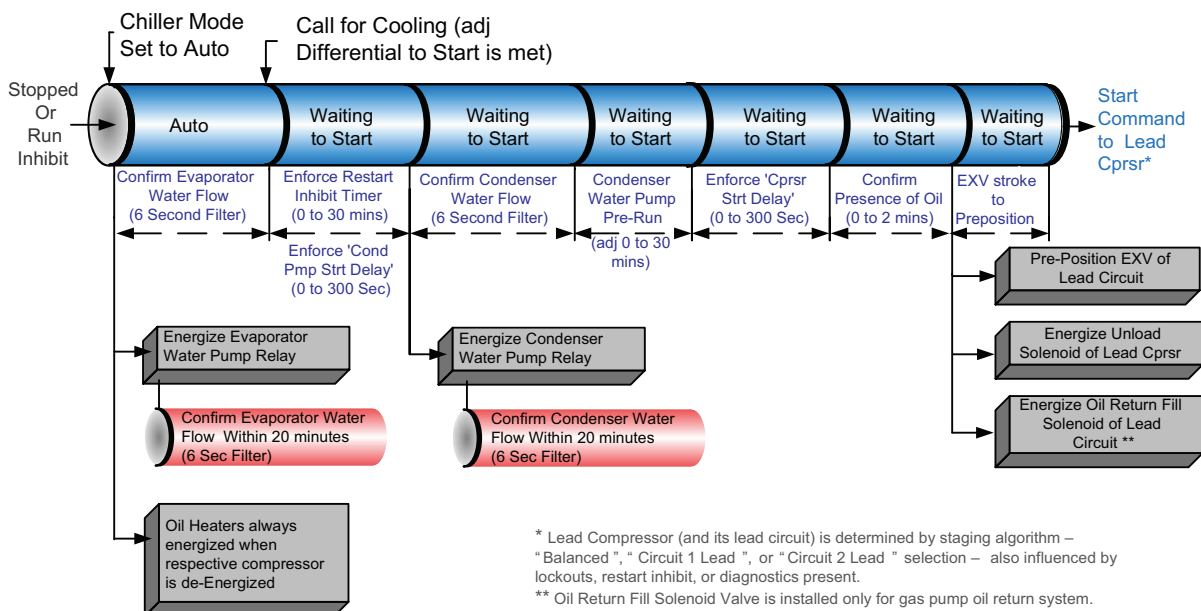

Start-Up and Shutdown

Normal Shutdown to Stopped

The following diagram shows the Transition from Running through a Normal (friendly) Shutdown. The dashed lines on

the top attempt to show the final mode if stop is selected via various inputs.

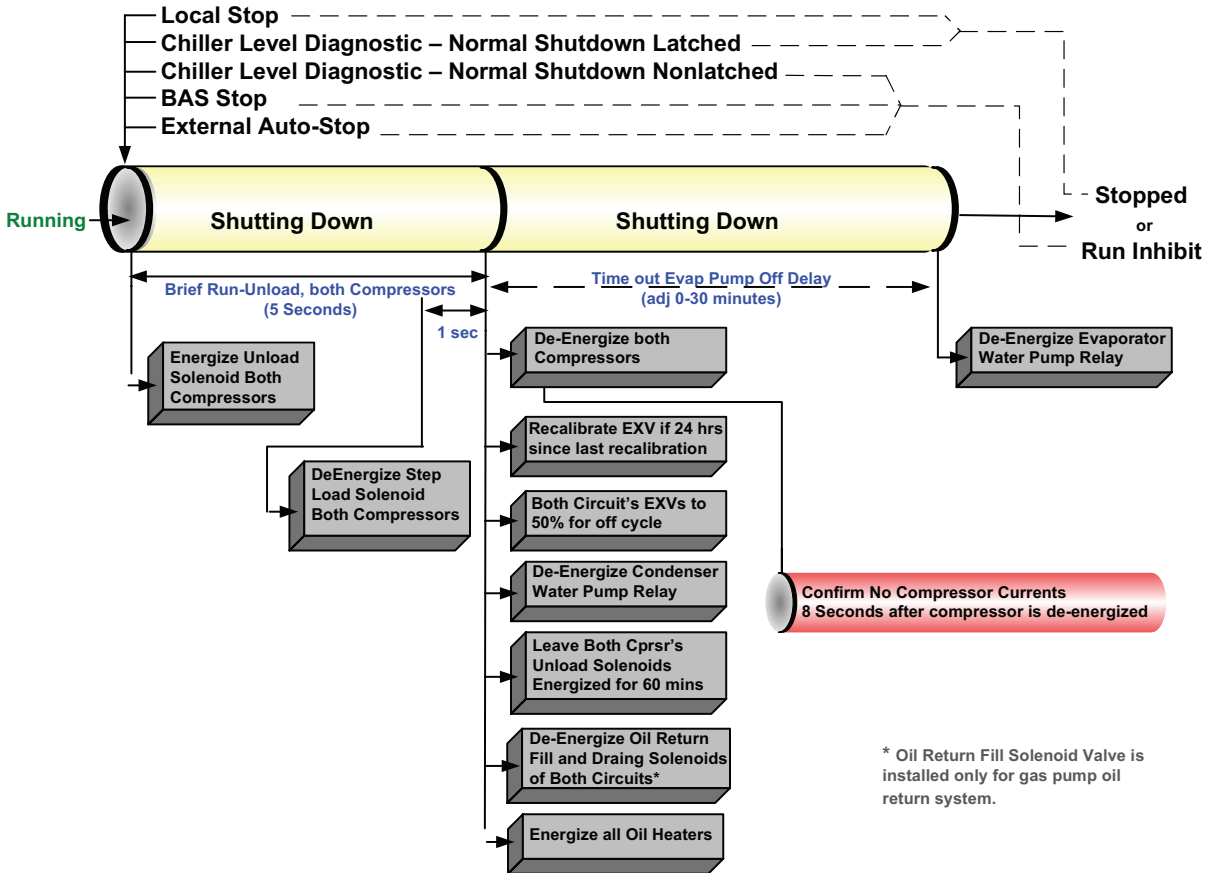



Maintenance

Overview and Maintenance Checks

This section describes preventative maintenance procedures and intervals. Use a periodic maintenance program to confirm optimal performance and efficiency of the Series R units.

An important aspect of the chiller maintenance program is the regular completion of operator logs. See Check Sheets chapter for an example. When filled out properly, the completed logs can be reviewed to identify any developing trends in the chiller's operating conditions.

⚠ WARNING

Hazardous Voltage!

Failure to disconnect power before servicing could result in death or serious injury.

Disconnect all electric power, including remote disconnects before servicing. Follow proper lockout/tagout procedures to ensure the power can not be inadvertently energized. Verify that no power is present with a voltmeter.

⚠ WARNING

Live Electrical Components!

Failure to follow all electrical safety precautions when exposed to live electrical components could result in death or serious injury.

When it is necessary to work with live electrical components, have a qualified licensed electrician or other individual who has been properly trained in handling live electrical components perform these tasks.

Weekly Maintenance and Checks

After the unit has operated for approximately 30 minutes and the system has stabilized, check the operating conditions and complete the procedures below:

- Log the chiller.
- Check evaporator and condenser pressures with gauges and compare to the reading on the unit chiller. Pressure readings should fall within the specified ranges listed in [Table 23, p. 66](#) and [Table 24, p. 66](#). If chiller measurements vary significantly from values listed, problems may exist with refrigerant and oil charge levels. Contact local Trane service.

Note: *Optimal condenser pressure is dependent on condenser water temperature, and should equal the saturation pressure of the refrigerant at a temperature 2 to 5°F above that of leaving condenser water at full load.*

Monthly Maintenance and Checks

- Review operator log.
- Clean all water strainers in both the chilled and condensing water piping systems.
- Measure and log the subcooling and superheat.
- See [“Refrigerant and Oil Charge Management,” p. 66](#). If chiller measurements vary significantly from values listed in [Table 23, p. 66](#) and [Table 24, p. 66](#), problems may exist with refrigerant and oil charge levels. Contact local Trane service.

Annual Maintenance

⚠ WARNING

Hazardous Voltage!

Failure to disconnect power before servicing could result in death or serious injury.

Disconnect all electric power, including remote disconnects before servicing. Follow proper lockout/tagout procedures to ensure the power can not be inadvertently energized. Verify that no power is present with a voltmeter.

Shut down the chiller once each year to check the following:

- Perform all weekly and monthly maintenance procedures.
- Have a qualified laboratory perform an oil analysis to determine system moisture content and acid level.
Note: *Due to the hygroscopic properties of the POE oil, all oil must be stored in metal containers. The oil will absorb water if stored in a plastic container.*
- Contact Trane service organization to leak check the chiller, to inspect safety controls, and inspect electrical components for deficiencies.
- Inspect all piping components for leakage and/or damage. Clean out any inline strainers.
- Clean and repaint any areas that show signs of corrosion.
- Inspect vent piping of all relief valves for presence of refrigerant to detect improperly sealed relief valves. Contact Trane service if unusual conditions are observed.
- Inspect the condenser tubes for fouling. Clean if necessary. See [“Cleaning the Condenser,” p. 66](#).
- Check to make sure that the crank case heater is working.

Scheduling Other Maintenance

- Use a nondestructive tube test to inspect the condenser and evaporator tubes at 3-year intervals.

Note: *It may be desirable to perform tube tests on these components at more frequent intervals, depending upon chiller application. This is especially true of critical process equipment.*

- Depending on chiller duty, contact a qualified service organization to determine when to conduct a complete examination of the unit to determine the condition of the compressor and internal components.

Refrigerant and Oil Charge Management

Proper oil and refrigerant charge is essential for proper unit operation, unit performance, and environmental protection. Only trained and licensed service personnel should service the chiller.

Tables below list baseline measurements for units running at AHRI standard operating conditions. If chiller measurements vary significantly from values listed below, problems may exist with refrigerant and oil charge levels. Contact Trane service.

Note: *AHRI conditions are: condenser water: 85°F and 3 GPM per ton and evaporator water: 54 to 44°F.*

Table 23. RTWD operation conditions at full load

Description	Condition	
	R515B	R513A
Refrigerant	R515B	R513A
Evaporator Pressure (psig)	21-25	38-44
Condensing Pressure (psig)	83-91	125-137
Discharge Superheat (°F)	13-23	14-24
Subcooling (°F)	7-11	7-12

Note: All conditions stated above are based on the unit running fully loaded at AHRI conditions. If full load conditions cannot be met, contact Trane service.

Table 24. RTWD operation conditions at minimum load

Description	Condition	
	R515B	R513A
Evaporator approach (°F)	0.3-2.7	0.2-2.7

Table 24. RTWD operation conditions at minimum load (continued)

Description	Condition	
	Condensing approach (°F)	0.4-2.9
Subcooling (°F)	3.3-5.2	3.6-5.3
EXV percent open (%)	15%-30	17%-35

Note: Conditions at minimum must be – entering condenser water: 85°F and entering evaporator water: 55°F.

Heat Exchanger Maintenance

Cleaning the Condenser

NOTICE

Proper Water Treatment Required!

The use of untreated or improperly treated water could result in scaling, erosion, corrosion, algae or slime.

Use the services of a qualified water treatment specialist to determine what water treatment, if any, is required. Trane assumes no responsibility for equipment failures which result from untreated or improperly treated water, or saline or brackish water.

Condenser tube fouling is suspected when the approach temperature (i.e., the difference between the refrigerant condensing temperature and the leaving condenser water temperature) is higher than predicted.

Standard water applications will operate with less than a 10°F approach. If the approach exceeds 10°F, cleaning the condenser tubes is recommended.

Note: *Glycol in the water system may as much as double the standard approach.*

If the annual condenser tube inspection indicates that the tubes are fouled, two cleaning methods can be used to rid the tubes of contaminants.

- Mechanical tube cleaning method is used to remove sludge and loose material from smooth-bore condenser tubes. See [“Mechanical Cleaning Procedure,” p. 67.](#)
- Chemical cleaning procedures are used to remove scale deposits. See [“Chemical Cleaning Procedure,” p. 69.](#)

Mechanical Cleaning Procedure

Table 25. RTWD condenser waterbox weights

Size	Hz	Effic	Waterbox	Weight - kg (lbs)	Lifting Connection
80, 90, 100, 110, 120, 130, 140	60	STD	Supply, Return	29 (64)	M12x1.75
80, 90, 100, 110, 120, 130	60	HIGH	Supply, Return		
150, 160, 180, 200, 220, 250	60	HIGH	Supply	38 (84)	M12x1.75
150, 160, 180, 200	60	PREM	Supply		
150, 160, 180, 200, 220, 250	60	HIGH	Return	42 (93)	M12x1.75
150, 160, 180, 200	60	PREM	Return		

⚠ WARNING

Heavy Objects!

Failure to properly lift waterbox could result in death or serious injury.

Each of the individual cables (chains or slings) used to lift the waterbox must be capable of supporting the entire weight of the waterbox. The cables (chains or slings) must be rated for overhead lifting applications with an acceptable working load limit. Refer to the waterbox weights table.

⚠ WARNING

Straight Vertical Lift Required!

Failure to properly lift waterbox in straight vertical lift could cause the eyebolts to break which could result in death or serious injury from object dropping.

The proper use and ratings for eyebolts can be found in ANSI/ASME standard B18.15. Maximum load rating for eyebolts are based on a straight vertical lift in a gradually increasing manner. Angular lifts will significantly lower maximum loads and should be avoided whenever possible. Loads should always be applied to eyebolts in the plane of the eye, not at some angle to this plane.

Review mechanical room limitations and determine the safest method or methods of rigging and lifting the waterboxes.

Select the proper waterbox removal procedure method as shown below.

Waterbox Removal Procedure - Method 1

This selection applies to the units and condenser side waterboxes. See [Table 26, p. 67](#).

Table 26. Waterbox removal procedure — method 1

Size	Hz	Effic	Condenser Waterbox
80, 90, 100, 110, 120, 130, 140	60	STD	Supply, Return
80, 90, 100, 110, 120, 130	60	HIGH	Supply, Return
150, 160, 180, 200, 220, 250	60	HIGH	Supply
150, 160, 180, 200	60	PREM	Supply

1. Select the proper lift connection device from [Table 29, p. 69](#). The rated lifting capacity of the selected lift connection device must meet or exceed the published weight of the waterbox. See [Table 25, p. 67](#) for waterbox weights.
2. Confirm the lift connection device has the correct connection for the waterbox. Example: Thread type (course/fine, English/metric), Bolt diameter (English/metric).
3. Properly connect the lift connection device to the waterbox. See [Figure 31, p. 67](#). Confirm the lift connection device is securely fastened.

Figure 31. Waterbox lifting

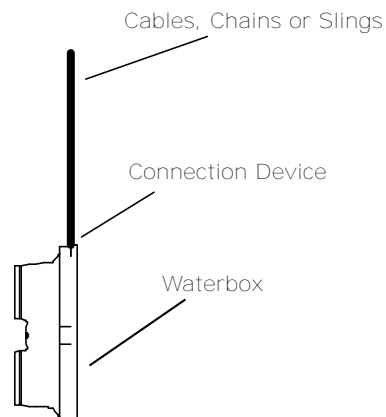

4. Install hoist ring on to the lifting connection on the waterbox. Torque to 28 ft-lbs (37 Nm).
5. Disconnect water pipes, if connected.
6. Remove waterbox bolts.
7. Lift the waterbox away from the shell.

Waterbox Removal Procedure - Method 2

This selection applies to the units and condenser side waterboxes. See [Table 27, p. 68](#).

Table 27. Waterbox removal procedure — method 2

Size	Hz	Effic	Condenser Waterbox
150, 160, 180, 200, 220, 250	60	HIGH	Return
150, 160, 180, 200	60	PREM	Return

⚠ CAUTION

Risk of Injury!

Failure to follow handling instructions below could result in minor to moderate injury.

Do not place hands or fingers between waterbox and condenser tubesheet.

1. Select the proper lift connection device from [Table 29, p. 69](#). The rated lifting capacity of the selected lift connection device must meet or exceed the published weight of the waterbox. See [Table 25, p. 67](#) for waterbox weights.
2. Confirm the lift connection device has the correct connection for the waterbox. Example: Thread type (course/fine, English/metric), Bolt diameter (English/metric).
3. Disconnect water pipes, if connected.
4. Remove the two bolts with drill point mark. Install the long bolts into these two holes until threads are fully engaged, and hand tight. The long bolts are located on the two thread holes just above the waterbox. See [Figure 32, p. 68](#).

Figure 32. Waterbox removal – remove bolts

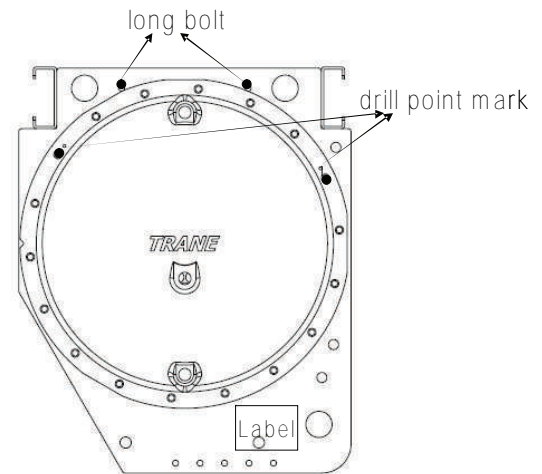

5. Remove the remaining bolts. Slide the waterbox out about 30 mm through two long bolts. Install the Safety Hoist ring (D ring) connection device into the tap drill hole located on waterbox right side (face to waterbox convex). See [Figure 33, p. 68](#).

Figure 33. Waterbox removal - slide out, install safety hoist ring

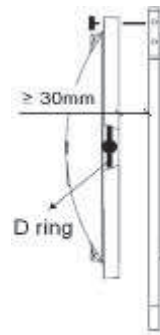

6. Remove the left long bolt while supporting waterbox from outside of waterbox. Swing the waterbox outboard. Put lifting chain on Safety Hoist ring and remove the remaining long bolt. See [Figure 34, p. 69](#).

Figure 34. Waterbox removal - swing out, install lifting chain

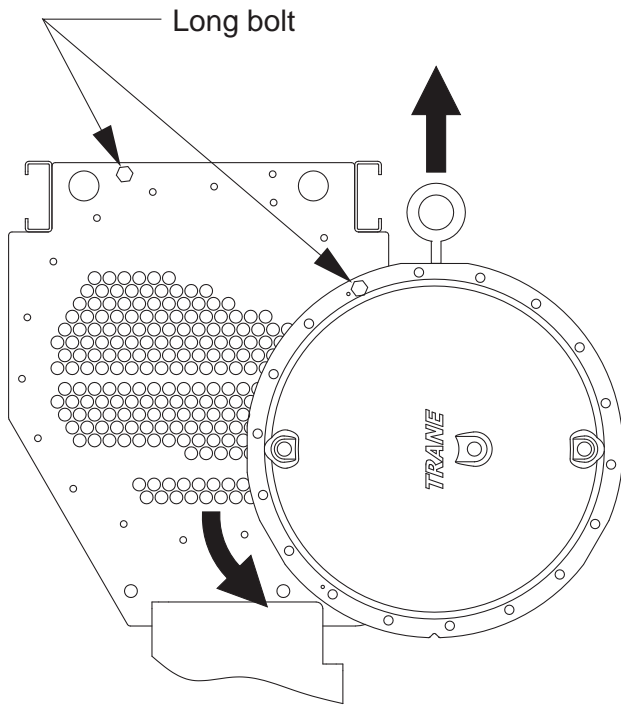

7. Lift the waterbox away from the shell.

⚠ WARNING

Overhead Hazard!

Failure to follow instructions could result in death or serious injuries.

Never stand below or in close proximity to heavy objects while they are suspended from, or being lifted by, a lifting device in case the object drops.

Condenser Tube Cleaning - Mechanical

1. Store waterbox/cover in a safe and secure location and position.

Important: Do not leave waterbox/cover suspended from lifting device.

2. Using a round nylon or brass bristled brush (attached to a rod) loosen the sludge in each of the condenser water tubes.
3. Thoroughly flush the condenser water tubes with clean water.

Note: To clean internally enhanced tubes, use a bidirectional brush or consult a qualified service.

Reassembly

Once service is complete, the waterbox/ cover should be reinstalled following all previous procedures in reverse.

- Use new o-rings or gaskets on all joints after thoroughly cleaning each joint. Contact local Trane parts center for information.
- Torque waterbox/cover bolts.

Note: Torque bolts in a star pattern. See the table below for torque values.

Table 28. Torque values – ft-lbs (Nm)

Evaporator	Condenser
65 (88)	65 (88)

Parts Ordering Information

Table 29. Lifting hardware

Unit	Product	Part Number
RTWD	Safety Hoist Ring M12x1.75	RNG01886

Obtain the required parts from local Trane Parts Center.

Chemical Cleaning Procedure

Scale deposits are best removed by chemical means. Consult a qualified water treatment specialist (i.e., one that knows the local water supply chemical/mineral content) for a recommended cleaning solution suitable for the job. (A standard condenser water circuit is composed solely of copper, cast iron, and steel.) Improper chemical cleaning can damage tube walls.

All of the materials used in the external circulation system, the quantity of the solution, the duration of the cleaning period, and any required safety precautions should be approved by the company furnishing the materials or performing the cleaning.

Note: Chemical tube cleaning should always be followed by mechanical tube cleaning.

Cleaning the Evaporator

Since the evaporator is typically part of a closed circuit, it does not accumulate appreciable amounts of scale or sludge. However, if cleaning is deemed necessary, use the same cleaning methods described for the condenser tubes.

See the table for evaporator waterbox weights.

Table 30. RTWD evaporator waterbox weights

Size	Hz	Effic	Waterbox	Weight - kg (lbs)	Lifting Connection
80, 90, 100, 110, 120, 130, 140	60	STD	Supply, Return	20.4 (45)	M12x1.75
80, 90, 100, 110, 120, 130	60	HIGH	Supply, Return		
150, 160, 180, 200, 220, 250	60	HIGH	Supply	33.6 (74)	M12x1.75
150, 160, 180, 200	60	PREM	Supply		
150, 160, 180, 200, 220, 250	60	HIGH	Return	29.9 (66)	M12x1.75
150, 160, 180, 200	60	PREM	Return		

Lubrication System

Compressor Oil

NOTICE

Equipment Damage!

Failure to follow instructions could result in oil sump heater burnout.

Open the unit main power disconnect switch before removing oil from the compressor.

Trane Polyolester Oil is the approved oil for RTWD units. Polyolester oil is extremely hygroscopic meaning it readily attracts moisture. The oil can not be stored in plastic containers due to the hygroscopic properties. If water is in the system, it will react with the oil to form acids. See the following table to determine the acceptability of the oil.

Description	Acceptable Levels
Moisture Content	less than 300 ppm
Acid Level	less than 0.5 TAN (mg KOH/g)

Note: Use an oil transfer pump to change the oil regardless of chiller pressure.

Oil Sump Level Check

Running the chiller at minimum load is the best for the quickest return of oil to the separator and sump. The machine still needs to sit for approximately 30 minutes before the level is taken. At minimum load, the discharge superheat should be highest. The more heat in the oil as it lays in the sump, the more refrigerant will boil off in the sump and leave more concentrated oil.

The oil level in the oil sump can be measured to give an indication of the system oil charge. Follow the procedures below to measure the level.

1. Run the unit fully unloaded for approximately 20 minutes.
2. Cycle the compressor off line.

NOTICE

Equipment Damage!

Operating compressors with service valves open will result in severe oil loss and equipment damage.

Never operate the compressor with the sight glass service valves opened. Close the valves after checking the oil level.

Figure 35. Determining oil level in the sump

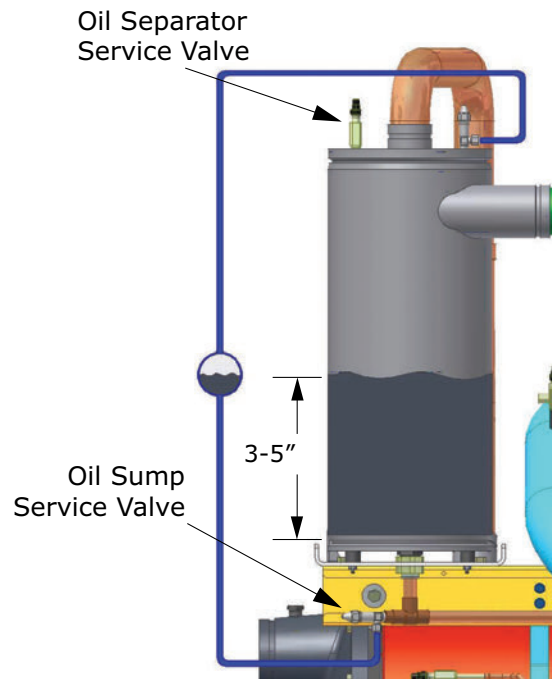

3. Attach a 3/8 inch or 1/2 inch hose with a sight glass in the middle to the oil sump service valve (1/4 inch flare) and the oil separator service valve (1/4 inch flare).

Note: Using high pressure rated clear hose with appropriate fittings can help speed up the process.

4. After the unit is off line for 30 minutes, move the sight glass along the side of the oil sump.
5. The level should be between 3 inch and 5 inch from the bottom of the oil sump.

Note: *If oil levels are not between 3 inch and 5 inch, contact Trane service.*

6. After the level is determined, close the service valves and remove the hose/sight glass assembly.



Diagnostics

General Diagnostics Information

Diagnostic Name and Source: Name of Diagnostic and its source. Note that this is the exact text used in the User Interface and/or Service Tool displays.

Affects Target: Defines the "target" or what is affected by the diagnostic. Usually either the entire Chiller, or a particular Circuit or Compressor is affected by the diagnostic (the same one as the source), but in special cases functions are modified or disabled by the diagnostic. "None" implies that there is no direct affect to the chiller, sub components or functional operation.

Design Note: Functions that are affected by a diagnostic are simply reported as "chiller or circuit x" targets in Tracer® TU and on the Alarms page of the AdaptiView™ display, even though only a specific function and not the entire circuit or chiller would be effected.

Severity: Defines the severity of the above effect. Immediate means immediate shutdown of the affected portion, Normal means normal or friendly shutdown of the affected portion, Special Action means a special action or mode of operation (limp along) is invoked, but without shutdown, and Info means an Informational Note or Warning is generated. Design Note: Tracer TU does not support display of "Special Action", on its Diagnostics pages, so that if a diagnostic has a special action defined in the table below, it will be displayed only as "Informational Warning" as long as no circuit or chiller shutdown results. If

there is a shutdown and special action defined in the table, then the Tracer TU Diagnostics Page display will indicate the shutdown type only.

Persistence: Defines whether or not the diagnostic and its effects are to be manually reset (Latched), or can be either manually or automatically reset when and if the condition returns to normal (Nonlatched).

Active Modes [Inactive Modes]: States the modes or periods of operation that the diagnostic is active in and, as necessary, those modes or periods that it is specifically "not active" in as an exception to the active modes. The inactive modes are enclosed in brackets, []. Note that the modes used in this column are internal and not generally announced to any of the formal mode displays.

Criteria: Quantitatively defines the criteria used in generating the diagnostic and, if nonlatching, the criteria for auto reset.

Reset Level: Defines the lowest level of manual diagnostic reset command which can clear the diagnostic. The manual diagnostic reset levels in order of priority are: Local or Remote. For example, a diagnostic that has a reset level of Remote, can be reset by either a remote diagnostic reset command or by a local diagnostic reset command.

Starter Diagnostics

Table 31. Starter diagnostics

Diagnostic Name	Affects Target	Severity	Persistence	Active Modes [Inactive Modes]	Criteria	Reset Level
Compressor Did Not Accelerate: Shutdown - xy	Cprsr	Immediate	Latch	Cprsr Accelerating	Acceleration Time Out Action set to Shutdown: Compressor motor current did not drop below 85% RLA within the Maximum Acceleration Setting setpoint. Compressor motor de-energized. See Current Overload Protection specification.	Local
Compressor Did Not Accelerate: Transition - xy	Cprsr	Warning	Latch	Start Mode	The compressor did not come up to speed (fall to <85% RLA) in the allotted time defined by the Maximum Acceleration Timer and a transition was forced (motor put across the line) at that time. This applies to all starter types.	Remote
Motor Current Overload - xy	Circuit	Immediate	Latch	Cprsr Energized	Compressor current exceeded overload time vs. trip characteristic. Must trip = 140% RLA, Must hold=125%, nominal trip 132.5% in 30 seconds	Local
Over Voltage	Chiller	Normal	NonLatch	Pre-Start and Any Ckt(s) Energzd	Nom. trip: 60 seconds at greater than 112.5%, ± 2.5%, Auto Reset at 110% or less for 10 continuous seconds.	Remote

Table 31. Starter diagnostics (continued)

Diagnostic Name	Affects Target	Severity	Persistence	Active Modes [Inactive Modes]	Criteria	Reset Level
Phase Loss - xy	Cprsr	Immediate	Latch	Start Sequence and Run modes	a) No current was sensed on one or two of the current transformer inputs while running or starting (See Non-latching Power Loss Diagnostic for all three phases lost while running). Must hold = 20% RLA. Must trip = 5% RLA. Time to trip shall be longer than guaranteed reset on Starter Module at a minimum, 3 seconds maximum. Actual design trip point is 10%. The actual design trip time is 2.64 seconds. b) If Phase reversal protection is enabled and current is not sensed on one or more current transformer inputs. Logic will detect and trip in a maximum of 0.3 seconds from compressor start.	Local
Phase Reversal - xy	Cprsr	Immediate	Latch	Compressor energized to transition command [All Other Times]	A phase reversal was detected on the incoming current. On a compressor start-up, the phase reversal logic must detect and trip in a maximum of 0.3 second from compressor start.	Local
Power Loss - xy	Cprsr	Immediate	NonLatch	All compressor running modes [all compressor starting and non-running modes]	The compressor had previously established currents while running and then all three phases of current were lost. Design: Less than 10% RLA, trip in 2.64 seconds. This diagnostic will preclude the Phase Loss Diagnostic and the Transition Complete Input Opened Diagnostic from being called out. To prevent this diagnostic from occurring with the intended disconnect of main power, the minimum time to trip must be greater than the guaranteed reset time of the Starter module. Note: This diagnostic prevents nuisance latching diagnostics due to a momentary power loss – It does not protect motor/compressor from uncontrolled power reapplication. See Momentary Power Loss Diagnostic for this protection. This diagnostic is not active during the start mode before the transition complete input is proven. Thus a random power loss during a start would result in either a “Starter Fault Type 3” or a “Starter Did Not Transition” latching diagnostic.	Remote
Severe Current Imbalance - xy	Circuit	Immediate	Latch	All Running Modes	A 30% Current Imbalance has been detected on one phase relative to the average of all 3 phases for 90 continuous seconds.	Local
Starter Comm Loss: Main Processor - xy	Cprsr	Immediate	Latch	All	The Starter module detected a continual loss of communication with the main processor for greater than the Communications Loss Time bound setpoint.	Local

Table 31. Starter diagnostics (continued)

Diagnostic Name	Affects Target	Severity	Persistence	Active Modes [Inactive Modes]	Criteria	Reset Level
Starter Contactor Interrupt Failure - xy	Chiller	Immediate and Special Action	Latch	Starter Contactor not Energized [Starter Contactor Energized]	Detected compressor currents greater than 10% RLA on any or all phases when the compressor was commanded off. Detection time is 5 second minimum and 10 seconds maximum. On detection and until the controller is manually reset: generate diagnostic, energize the appropriate alarm relay, continue to command the affected compressor off, fully unload the effected compressor, and command a normal stop to all other compressors. For as long as current continues, keep both the Evap and Cond pumps in an override-on mode, perform liquid level, oil return, and condenser head pressure control on the circuit effected.	Local
Starter Did Not Transition - xy	Cprsr	Immediate	Latch	On the first check after transition	The Starter Module did not receive a transition complete signal in the designated time from its command to transition. The Must Hold time from the Starter Module transition command is 1 second. The Must Trip time from the transition command is 6 seconds. Actual design is 2.5 seconds. This diagnostic is active only for Y-Delta, Auto-Transformer, Primary Reactor, and X-Line Starters.	Local
Starter Dry Run Test - xy	Cprsr	Immediate	Latch	Starter Dry Run Mode	While in the Starter Dry Run Mode either 50 % Line Voltage was sensed at the Potential Transformers or 10 % RLA Current was sensed at the Current Transformers.	Local
Starter Failed to Arm/Start - xy	Cprsr	Immediate	Latch	All	Starter failed to arm or start within the allotted time (15 seconds).	Local
Starter Fault Type I - xy	Cprsr	Immediate	Latch	Starting - Y Delta Starters Only	This is a specific starter test where 1M(1K1) is closed first and a check is made to confirm that there are no currents detected by the CT's. If currents are detected when only 1M is closed first at start, then one of the other contactors is shorted.	Local
Starter Fault Type II - xy	Cprsr	Immediate	Latch	Starting - All types of starters	a. This is a specific starter test where the Shorting Contactor (1K3) is individually energized and a check is made to confirm that there are no currents detected by the CT's. If current is detected when only S is energized at Start, then 1M is shorted. b. This test in a. above applies to all forms of starters (Note: It is understood that many starters do not connect to the Shorting Contactor.).	Local

Table 31. Starter diagnostics (continued)

Diagnostic Name	Affects Target	Severity	Persistence	Active Modes [Inactive Modes]	Criteria	Reset Level
Starter Fault Type III - xy	Cprsr	Immediate	Latch	Starting [Adaptive Frequency Starter Type]	As part of the normal start sequence to apply power to the compressor, the Shorting Contactor (1K3) and then the Main Contactor (1K1) were energized. 1.6 seconds later there were no currents detected by the CT's for the last 1.2 Seconds on all three phases. The test above applies to all forms of starters except Adaptive Frequency Drives.	Local
Starter Module Memory Error Type 1 - xy	Cprsr	Warning	Latch	All	Checksum on RAM copy of the Starter LLID configuration failed. Configuration recalled from EEPROM.	Local
Starter Module Memory Error Type 2 - xy	Cprsr	Immediate	Latch	All	Checksum on EEPROM copy of the Starter LLID configuration failed. Default configuration loaded into RAM and EEPROM.	Local
Transition Complete Input Opened - xy	Cprsr	Immediate	Latch	All Running Modes	The Transition Complete input was found to be opened with the compressor motor running after a successful completion of transition. This is active only for Y-Delta, Auto-Transformer, Primary Reactor, and X-Line Starters. To prevent this diagnostic from occurring as the result of a power loss to the contactors, the minimum time to trip must be greater than the trip time for the power loss diagnostic.	Local
Transition Complete Input Shorted - xy	Cprsr	Immediate	Latch	Pre-Start	The Transition Complete input was found to be shorted before the compressor was started. This is active for all electromechanical starters.	Local
Under Voltage	Chiller	Normal	NonLatch	Pre-Start and Any Ckt(s) Energzd	Nom. trip: 60 seconds at less than 87.5%, $\pm 2.8\%$ at 200V $\pm 1.8\%$ at 575V, Auto Reset at 90% or greater for 10 continuous seconds.	Remote
Unexpected Starter Shutdown - xy	Cprsr	Normal	NonLatch	All Cprsr Running modes, Starting, Running and Preparing to Shutdown	The Starter module status reported back that it is stopped when the MP thinks it should be running and no Starter diagnostic exist. This diagnostic will be logged in the active buffer and then automatically cleared. This diagnostic could be caused by intermittent communication problems from the Starter to the MP, or due to mis-binding.	Local



Main Processor Diagnostics

Table 32. Main processor diagnostics

Diagnostic Name	Affects Target	Severity	Persistence	Active Modes [Inactive Modes]	Criteria	Reset Level
BAS Communication Lost	Chiller	Warning and Special Action	NonLatch	All	The BAS was setup as "installed" at the MP and the Lontalk LCIC lost communications with the BAS for 15 contiguous minutes after it had been established. Refer to Section on Setpoint Arbitration to determine how setpoints and operating modes may be affected by the comm loss. The chiller follows the value of the Tracer Default Run Command which can be previously written by Tracer and stored nonvolatile by the MP (either use local or shutdown). Note that this diagnostic is never operational for BacNet Communication interface (BCIC) and only operational with a LonTalk Communication interface (LCIC) if so configured by the BAS or Tracer system.	Remote
Low Condenser Rfght Temp Circuit 2: Unit Off	Chiller	Special Action	NonLatch	Unit in Stop Mode, or in Auto Mode and No Ckt(s) Energized [Any Ckt Energized]	This diagnostic is based on dew point from condenser refrigerant pressure transducer of circuit 2 falling below the Condenser Freeze Avoidance Setpoint. When this diagnostic is active, both the Condenser Water Freeze Avoidance Request Relay is turned on and the Condenser Water Pump request is placed in a "Diagnostic Override mode" and forced on regardless of the chiller mode. The diagnostic is auto cleared when both the saturated temperature is 2°F (1.1°C) above the Condenser Freeze Avoidance Setpoint for 1 minute and the anti short cycling count down calculation reaches 0 (see Low Rfght Condenser Temperature Protection spec), or with the start of either circuit. This diagnostic even while active, does not prevent operation of either circuit.	Remote
BAS Failed to Establish Communication	Chiller	Warning and Special Action	NonLatch	At power-up	The BAS was setup as "installed" and the BAS did not communicate with the Lontalk LCIC within 15 minutes after chiller controls power-up. Refer to Section on Setpoint Arbitration to determine how setpoints and operating modes may be affected. Note that this diagnostic is never operational for BacNet Communication interface (BCIC) and only operational with a LonTalk Communication interface (LCIC) if so configured by the BAS or Tracer system.	Remote
Chiller Service Recommended	Chiller	Warning	Latch	Service Messages Enabled	Chiller service interval time has elapsed. Chiller service is recommended.	Remote

Table 32. Main processor diagnostics (continued)

Diagnostic Name	Affects Target	Severity	Persistence	Active Modes [Inactive Modes]	Criteria	Reset Level
Compressor Discharge Refrigerant Temperature Sensor - xy	Cprsr	Immediate	Latch	All	Bad Sensor or LLID	Remote
Condenser Entering Water Temperature Sensor	Chiller	Warning and Special Action	Latch	All	Bad Sensor or LLID. If chiller running, and condenser water regulating valve option installed, force valve to 100% flow.	Remote
Condenser Leaving Water Temperature Sensor	Chiller	Warning and Special Action	Latch	All	Bad Sensor or LLID. If Chiller is running in the heat mode of operation – normal chiller shutdown, otherwise, informational warning only. Discontinue Min Capacity Limit forced cprsr loading due to Low DP in subsequent start-ups.	Remote
Condenser Refrigerant Pressure Sensor	Circuit	Immediate	Latch	All	Bad Sensor or LLID	Remote
Condenser Water Flow Lost	Chiller	Immediate	NonLatch	Cond Water Flow Previously Established – Start and all Run Modes [All Stop modes]	The Condenser water flow proof input was open for more than 6 contiguous seconds after flow had been proven. In Normal Cooling or Ice Building Mode, the Cond Pump is commanded off and this diagnostic is automatically cleared once the compressor is stopped by a fixed time out of 7 seconds. This diagnostic may stop the Evaporator Pump pursuant to other possible diagnostic overrides. In the Heating Mode, this diagnostic does not affect the Cond Pump output and 6 seconds of flow will auto-reset the diagnostic.	Remote
Condenser Water Flow Overdue	Chiller	Normal	NonLatch	Start Sequence Attempting to Establish Condenser Flow [All Stop modes]	Condenser water flow was not proven within 20 minutes of the Condenser Water Pump relay being energized. The Cond Pump shall be commanded off in Cooling and Ice Building modes, and remain on in the Heating Mode. The diagnostic is auto-reset with return of flow (although only possible with external control of pump). This diagnostic will generally also stop the Evaporator Pump pursuant to other possible diagnostic overrides.	Remote
Emergency Stop Feedback Input	Chiller	Immediate	Latch	All	a. Emergency stop feedback input is open. An external interlock has tripped. Time to trip from input opening to unit stop shall be 0.1 to 1.0 seconds.	Local
Energy Meter Write Value Failure	Chiller	Warning	Latch	All	Energy meter failed to return the expected value. <i>(Note: Only applies to Trane Enercept Flex Modbus Energy Meter)</i>	Remote

Table 32. Main processor diagnostics (continued)

Diagnostic Name	Affects Target	Severity	Persistence	Active Modes [Inactive Modes]	Criteria	Reset Level
Evap Rfght Liquid Level Sensor – Cktx	Circuit	Normal	Latch	All	Bad Sensor or LLID	Remote
Evaporator Approach Error	Circuit	Immediate	Latch	Respective circuit running	The Evaporator approach temperature for the respective circuit (ELWT – Evap Sat Temp Ckt x) is negative by more than $\max(10^{\circ}\text{F}, \text{Cooling Design Delta Temp}(\text{waterside}))$ for 1 minute continuously while the circuit / compressor is operating. Either the Evap Leaving Water Temp sensor or Evap Suction Rfght Pressure Sensor Ckt x is in error. note: 'Cooling Design Delta Temp(waterside)' is the TU setpoint	Remote
Evaporator Entering Water Temperature Sensor	Chiller	Normal	Latch	All	Bad Sensor or LLID. Note: Entering Water Temp Sensor is used in EXV pressure control as well as ice making so it must cause a unit shutdown even if ice or CHW reset is not installed.	Remote
Evaporator Leaving Water Temperature Sensor	Chiller	Normal	Latch	All	Bad Sensor or LLID	Remote
Evaporator Water Flow Lost	Chiller	Immediate	NonLatch	[All Stop Modes]	The Evaporator water flow proof input was open for more than 6 contiguous seconds. In the Normal Cooling and Ice Building Modes, this diagnostic does not affect the Evap Pump output, and it will generally remain on, In the Heating Mode of operation, the Evap Pump shall be commanded off excepting any freeze avoidance diagnostic overrides. 6 seconds of contiguous flow shall auto-reset this diagnostic.	Remote
Evaporator Water Flow Overdue	Chiller	Normal	NonLatch	Estab. Evap. Water Flow on going from STOP to AUTO or Evap Pump Override	The evaporator water flow was not proven within 20 minutes of the Evaporator Water Pump Relay being energized in normal "Stop" to "Auto" transition. In the case where the pump is overridden to "On" per certain freeze avoidance diagnostics, the delay on the callout of this diagnostic will be shortened to 255 seconds. In Cooling and Ice Building Modes the pump command status will not be affected by this diagnostic and it will generally remain on. In the Heating Mode of Operation, this diagnostic will generally force the pump to be off, excepting certain freeze avoidance diagnostic overrides.	Remote
Excessive Condenser Pressure	Circuit	Immediate	Latch	All	The condenser pressure sensor of this circuit has detected a condensing pressure in excess of the design high side pressure as limited by the particular compressor type.	Remote

Table 32. Main processor diagnostics (continued)

Diagnostic Name	Affects Target	Severity	Persistence	Active Modes [Inactive Modes]	Criteria	Reset Level
External Chilled Water/ Hot Water Setpoint	Chiller	Warning	NonLatch	All	a. Function Not "Enabled": no diagnostics. b. "Enabled ": Out-Of-Range Low or Hi or bad LLID, set diagnostic, default CWS to next level of priority (for example Front Panel SetPoint).	Remote
External Demand Limit Setpoint	Chiller	Warning	Latch	All	a. Not "Enabled": no diagnostics. b. "Enabled ": Out-Of-Range Low or Hi or bad LLID, set diagnostic, default CLS to next level of priority (for example Front Panel SetPoint.)	Remote
Fan Inverter Fault	Circuit (fan control)	Special Mode (or in single fan deck: Circuit Immediate shutdown	NonLatch (or in single fan deck: Latch)	Prestart and Running w/ Low Ambient Variable Spd Fan configured	A fault signal has been detected from the respective condenser's Variable Speed Inverter Drive (fan). Condenser Fan control will revert to constant speed operation without the use of the inverter's fan. If the inverter's fault clears, fan control will switch back to variable speed. For single fan deck configurations, this diagnostic causes a latching circuit shutdown	Remote
High Compressor Refrigerant Discharge Temp - xy	Cprsr	Immediate	Latch	All [compressor run unload or compressor not running]	The compressor discharge temperature exceeded 199.4°F (without oil cooler) or 230°F (with oil cooler). This diagnostic will be suppressed during Stopping mode or after the compressor has stopped. Note: As part of the Compressor High Temperature Limit Mode (aka Minimum Capacity Limit), the compressor shall be forced loaded as the filtered discharge temperature reaches 190°F (without oil coolers), or 220°F (with oil coolers).	Remote
High Differential Refrigerant Pressure - xy	Cprsr	Normal	Latch	Cprsr Energized	High Vi GP2 Cprsr : The differential pressure for the respective compressor was above 275 psid (1890 kPa) for 2 consecutive samples 5 seconds apart. Low Vi GP2 Cprsr: 188 psid (1296 kPa)	Remote
High Evaporator Refrigerant Pressure	Chiller	Immediate	NonLatch	Any Ckt Energized [Stop]	The evaporator saturated temperature (circuit1 or circuit2) has risen above 76F (24.4°C) for R513A or 82°F (27.8°C) for R1234ze(E)/R515B for more than 5 minutes. The diagnostic will auto reset when all of the evaporator saturated temperatures fall below limit temperature minus 0.5K. The ignore time (default 5 minutes) is configurable with level4 parameter Suction Pressure Tracking Time. If it is set to zero, the diagnostic is disabled.	Remote

Table 32. Main processor diagnostics (continued)

Diagnostic Name	Affects Target	Severity	Persistence	Active Modes [Inactive Modes]	Criteria	Reset Level
High Evaporator Water Temperature	Chiller	Warning and Special Action	NonLatch	Only effective if either 1) Evap Wtr Flow Overdue, 2) Evap Wtr Flow Loss, or 3) Low Evap Rfgt Temp,-Unit Off, diagnostic is active.	Either the leaving or the entering water temperature exceeded the high evap water temp limit (TU service menu settable –default 105°F (65.55°C), range 80°F (26.67°C)-150°F(65.55°C) for 15 continuous seconds. The evaporator water pump relay will be de-energized to stop the pump but only if it is running due one of the diagnostics listed on the left. The diagnostic will auto reset and the pump will return to normal control when both the entering and leaving temperatures fall 5°F below the trip setting. The primary purpose is to stop the evaporator water pump and its associated pump heat from causing excessive waterside temperatures and waterside pressures when the chiller is not running but the evap pump is on due to either Evap Water Flow Overdue, Evaporator Water Flow Loss , or Low Evap Temp – Unit Off Diagnostics. This diagnostic will not auto clear solely due to the clearing of the enabling diagnostic.	Remote
High Motor Winding	Cprsr	Immediate	Latch	All	Any of the compressor's motor winding temperature sensors (RTD) is seen to be beyond the windings rated temperature of 265°F (129.4°C)	Local
High Motor Winding Temperature - xA	Cprsr	Immediate	Latch	All	The respective compressor's motor winding thermostat is detected to be open. The compressor shall stop within 5 seconds of this diagnostic.	Local
High Pressure Cutout - xy	Cprsr	Immediate	Latch	All	A high pressure cutout was detected.	Local
High Refrigerant Pressure Ratio - xy	Cprsr	Immediate	Latch	Cprsr Energized	High Vi GP2 Cprsr : The pressure ratio for the respective compressor exceeded 12.3 for 1 contiguous minute while any compressor is running normally or in service pumpdown. This pressure ratio is a fundamental limitation of the particular compressor design. The pressure ratio is defined as Pcond (abs)/Pevap(abs) Low Vi GP2 Cprsr: 5.61.	Remote
Inverted Evaporator Water Temperature	Chiller	Warning/Normal	NonLatch/Latch	Any Ckt Energized [No Ckts Energized]	The entering evaporator water temp fell below the leaving evaporator water temp by more than 2°F for 180 °F-sec, minimum trip time 30 seconds. Diagnostic will auto clear if the leaving water temp – entering water temp < 2°F. It can warn of improper flow direction through the evaporator, misbound water temperature sensors, improper sensor installation, grossly inaccurate sensors, or other system problems. Note that either entering or leaving water temp sensor or the water system could be at fault.	Remote

Table 32. Main processor diagnostics (continued)

Diagnostic Name	Affects Target	Severity	Persistence	Active Modes [Inactive Modes]	Criteria	Reset Level
Loss of Oil for Compressor (Running)	Circuit	Immediate	Latch	Starter Contactor Energized	In running modes, Oil Loss Level Sensor detects lack of oil in the oil sump feeding the compressor (distinguishing a liquid flow from a vapor flow).	Local
Loss of Oil for Compressor (Stopped)	Circuit	Immediate and Special Action	Latch	Compressor Pre-Start [all other modes]	Oil Loss Level Sensor detects a lack of oil in the oil sump feeding the compressor for 90 seconds after EXV preposition is completed (and before EXV equalization, if applicable) on an attempted circuit start. Note: Compressor start is delayed pending oil detection during that time, but not allowed once the diagnostic occurs.	Local
Low Condenser Rfght Temp Circuit 1: Unit Off	Chiller	Special Action	NonLatch	Unit in Stop Mode, or in Auto Mode and No Ckt(s) Energized [Any Ckt Energized]	This diagnostic is based on dew point from condenser refrigerant pressure transducer of circuit 1 falling below the Condenser Freeze Avoidance Setpoint. When this diagnostic is active, both the Condenser Water Freeze Avoidance Request Relay is turned on and the Condenser Water Pump request is placed in a "Diagnostic Override mode" and forced on regardless of the chiller mode. The diagnostic is auto cleared when both the saturated temperature is 2°F (1.1°C) above the Condenser Freeze Avoidance Setpoint for 1 minute and the anti short cycling count down calculation reaches 0 (see Low Rfght Condenser Temperature Protection spec), or with the start of either circuit. This diagnostic even while active, does not prevent operation of either circuit.	Remote
Low Differential Refrigerant Pressure - xy	Cprsr	Immediate	Latch	Cprsr Energized	For start-up, please refer to oil flow protection spec. For running, the system differential pressure for the respective circuit was below the greater of 25 psid (240.5 kPa) or the pressure ratio listed in the table in GP2 Compressor Type FSpec while the compressor is running for a period of time dependent on the deficit (15 seconds ignore time from circuit start) – refer to the Oil Flow Protection specification for the time to trip function.	Remote
Low Discharge Superheat - xy	Cprsr	Normal	Latch	Any Running Mode	While Running Normally, the Compressor Discharge Superheat was less than the Low Discharge Superheat Setpoint (default 10°F) for more than 6500 degree F seconds. At circuit start-up, the Discharge Superheat will be ignored for 5 minutes.	Remote



Diagnostics

Table 32. Main processor diagnostics (continued)

Diagnostic Name	Affects Target	Severity	Persistence	Active Modes [Inactive Modes]	Criteria	Reset Level
Low Evaporator Refrigerant Pressure - Cktx	Circuit	Immediate	Latch	Cprsr Prestart and Cprsr Energized	<p>a. The Evaporator Pressure (as measured by the cprsr(s) suction pressure transducers) for the respective circuit, dropped below 10 Psia just prior to the circuit's 1st compressor start (after EXV preposition). b. During Early Start-up Period: the Evaporator Pressure fell 10 psia. c. After Early Start-up Period expires: The Evaporator Pressure fell below 16 Psia.</p> <p>(Note: the Early Start-up Period is fixed at 3 minutes relative to the start of the 1st cprsr of the ckt. If ckt is manifolded, the Evap pressure is defined by the lower of the two manifolded compressor suction pressures.)</p>	Local
Low Evaporator Refrigerant Temperature	Circuit	Immediate	Latch	All Ckt Running Modes	<p>The warmer of either the either the Evaporator Refrigerant Pool Temperature or Active Rfght Sat Temp for the respective circuit dropped below the Low Refrigerant Temperature Cutout Setpoint for 1125°F-sec (12°F-sec max rate for early circuit start-up period) while the circuit was running. The minimum LRTC setpoint is -5°F the point at which oil separates from the refrigerant. The integral is held nonvolatile though power down, is continuously calculated, and can decay or build during the circuit off cycle as conditions warrant.</p>	Local
Low Evaporator Refrigerant Temperature Circuit 1: Unit Off	Chiller	Special Action	NonLatch	Unit in Stop Mode, or in Auto Mode and No Ckt(s) Energized [Any Ckt Energized]	<p>The respective circuit's LERTC Integral was seen to be > 0 while the chiller is in the Stop mode, or in Auto mode with no compressors running for at least one minute. The LERTC integral is increased if the Evap Refrigerant Pool Temp is below the value of the Low Evap Rfght Temp Cutout + 2°F. Energize Evap Water Pump and Off-Cycle Freeze Avoidance Request Relay until diagnostic auto resets, then return to normal evap pump control and de-energize the Freeze Avoidance Request. Automatic reset occurs when the respective Evap Rfght Pool Temp rises 4°F(1.1°C) above the LERTC cutout setting for 1 minute and the Chiller Off LERTC Integral = 0.. This diagnostic even while active, does not prevent operation of either circuit.</p>	Remote

Table 32. Main processor diagnostics (continued)

Diagnostic Name	Affects Target	Severity	Persistence	Active Modes [Inactive Modes]	Criteria	Reset Level
Low Evaporator Refrigerant Temperature Circuit 2: Unit Off	Chiller	Special Action	NonLatch	Unit in Stop Mode, or in Auto Mode and No Ckt(s) Energized [Any Ckt Energized]	The respective circuit's LERTC Integral was seen to be > 0 while the chiller is in the Stop mode, or in Auto mode with no compressors running for at least one minute. The LERTC integral is increased if the Evap Refrigerant Pool Temp is below the value of the Low Evap Rfght Temp Cutout + 2°F. Energize Evap Water Pump and Off-Cycle Freeze Avoidance Request Relay until diagnostic auto resets, then return to normal evap pump control and de-energize the Freeze Avoidance Request. Automatic reset occurs when the respective Evap Rfght Pool Temp rises 4°F(1.1°C) above the LERTC cutout setting for 1 minute and the Chiller Off LERTC Integral = 0.. This diagnostic even while active, does not prevent operation of either circuit.	Remote
Low Evaporator Water Temperature (Unit Off)	Chiller	Special Action	NonLatch	Unit in Stop Mode, or in Auto Mode and No Ckt(s) Energized [Any Ckt Energized]	Either the entering or leaving evaporator water temp fell below the leaving water temp cutout setting for 30 degree F-seconds while the Chiller is in the Stop mode, or in Auto mode with no compressors running. Energize Freeze Avoidance Request Relay and Evap Water Pump Relay until diagnostic auto resets, then de-energize the Freeze Avoidance Request Relay and return to normal evap pump control. Automatic reset occurs when both temps rise 2°F (1.1°C) above the cutout setting for 5 minutes, or either circuit starts. This diagnostic even while active, does not prevent operation of either circuit.	Remote
Low Evaporator Water Temperature (Unit On)	Chiller	Immediate and Special Action	NonLatch	Any Ckt[s] Energized [No Ckt(s) Energized]	The evaporator entering or leaving water temperature fell below the cutout setpoint for 30 degree F Seconds while the compressor was running. Automatic reset occurs when both of the temperature rises 2°F(1.1°C) above the cutout setting for 2 minutes. This diagnostic shall not de-energize the Evaporator Water Pump Output.	Remote
Low Oil Flow - xy	Cprsr	Immediate	Latch	Cprsr Energized and Delta P above 15 Psid	The intermediate oil pressure sensor for this compressor was out of the acceptable pressure range for 15 seconds, while the Delta Pressure was greater than 15 Psid (172.4 kPa).: Acceptable range is 0.50 > (PC-PI) / (PC-PE) for the first 2.5 minutes of operation, and 0.28 > (PC-PI) / (PC-PE) thereafter.	Local
Main Power Loss	Chiller	Immediate Shutdown and Special Action	NonLatch	All	As soon as Main Power is lost, diagnostic is triggered. Diagnostic will be released after 6 seconds debounce time. Energize Evap Water Pump Relay until diagnostic auto resets, then return to normal evap pump control.	Local

Table 32. Main processor diagnostics (continued)

Diagnostic Name	Affects Target	Severity	Persistence	Active Modes [Inactive Modes]	Criteria	Reset Level
Manufacturer Maintenance Recommended - xy	Cprsr	Warning	Latch	Service Messages Enabled	Compressor service recommended as service interval hours have elapsed.	Remote
Motor Winding Temp Sensor - xy	Cprsr	Warning (tunable)	Latch	All	Both of the motor winding temperature sensors are seen to be out of their normal range. (Severity is adjustable via TU Service Tool – default is warning)	Local
MP: Invalid Configuration	Chiller	Immediate	Latch	All	Reported if state chart misalignment in stopped or inactive state occurred while a compressor was seen to be operating and this condition lasted for at least 1 minute (cprsr operation due to Service Pumpdown or with Contactor Interrupt Failure diagnostic is excluded). The presence of this software error message suggests an internal software problem has been detected. The events that led up to this failure, if known, should be recorded and transmitted to Trane Controls Engineering.	Local
MP: Reset Has OccurredC3: I8H63C3:H7C3: I9H63C3:H7C3: I11H63C3:I58	Platform	Warning	NonLatch	All	The main processor has successfully come out of a reset and built its application. A reset may have been due to a power up, installing new software or configuration. This diagnostic is immediately and automatically cleared and thus can only be seen in the Historic Diagnostic List in Tracer TU.	Remote
No Differential Refrigerant Pressure - xy	Cprsr	Immediate	Latch	Compressor running on Circuit	The system differential pressure was below 7.7 Psid (53 kPa) for 6 seconds after the 11 seconds ignore time relative to cprsr/circuit start-up had expired. In a two compressor circuit, the lower of the two suction pressure is used for circuit DP.	Remote
Oil Flow Protection Fault - xy	Cprsr	Immediate	Latch	Starter Contactor Energized [all Stop modes]	The Intermediate Oil Pressure Sensor for this cprsr is reading a pressure either above its respective circuit's Condenser Pressure by 15 Psid or more, or below its respective compressor Suction Pressure 10 Psid or more for 30 seconds continuously.	Local
Oil Pressure Sensor - xy	Cprsr	Immediate	Latch	All	Bad Sensor or LLID	Remote
Outdoor Air Temperature Sensor	Chiller	Warning	Latch	All	Bad Sensor or LLID. If the outdoor temperature is used for CHW reset, there shall be no CHW reset. Apply slew rates per Chilled Water Reset spec. If installed for low ambient lockout, there shall be no LA lockout imposed.	Remote
Pumpdown Terminated – Cktx	Circuit	Warning	NonLatch	All	RTUD A/C only: Pumpdown was early terminated (abnormal cause or expiration time) and Evaporator Liquid Level is above -36mm whereas circuit is stopped.	Remote

Table 32. Main processor diagnostics (continued)

Diagnostic Name	Affects Target	Severity	Persistence	Active Modes [Inactive Modes]	Criteria	Reset Level
Pumpdown Terminated By Time	Circuit	Warning	Latch	Service Pumpdown	Service Pumpdown cycle for this circuit was terminated abnormally due to excessive time. Refer to Service Pumpdown spec for maximum time allowed.	Local
Restart Inhibit Invoked - xy	Cprsr	Warning	NonLatch	All	When restart inhibit warning is enabled, the warning exists when unit has been inhibited from starting and is cleared when a start of a compressor is possible (Start-to-Start Timer expires).	Remote
Software Error 1001: Call Trane Service	Chiller	Immediate	Latch	All	A high level software watchdog has detected a condition in which there was a continuous 1-minute period of compressor operation, with neither Evaporator water flow nor a "contactor interrupt failure" diagnostic active. The presence of this software error message suggests an internal software problem has been detected. The events that led up to this failure, if known, should be recorded and transmitted to Trane Controls Engineering.	Local
Software Error 1002: Call Trane Service	Chiller	Immediate	Latch	All	Reported if state chart misalignment in stopped or inactive state occurred while a compressor was seen to be operating and this condition lasted for at least 1 minute (cprsr operation due to Service Pumpdown or with Contactor Interrupt Failure diagnostic is excluded). The presence of this software error message suggests an internal software problem has been detected. The events that led up to this failure, if known, should be recorded and transmitted to Trane Controls Engineering.	Local
Software Error 1003: Call Trane Service	Chiller	Immediate	Latch	All	Reported if state chart misalignment occurred inferred from the Capacity Control, Circuit, or Compressor State Machines remaining in the Stopping state for more than 3 minutes. The presence of this software error message suggests an internal software problem has been detected. The events that led up to this failure, if known, should be recorded and transmitted to Trane Controls Engineering.	Local
Starter Panel High Temp Limit – Compressor 1A	Circuit	Immediate and Special Action	NonLatch	All	Starter Panel High Limit Thermostat (170°F) trip was detected. Compressor 1A is shutdown and inoperative until the thermostat resets. Note: Other diagnostics that may occur as an expected consequence of the Panel High Temp Limit trip will be suppressed from annunciation. These include Momentary Power Loss, Phase Loss, Power Loss, and Transition Complete Input for Compressor 1A.	Local

Diagnostics

Table 32. Main processor diagnostics (continued)

Diagnostic Name	Affects Target	Severity	Persistence	Active Modes [Inactive Modes]	Criteria	Reset Level
Starts/Hours Modified - xy	Cprsr	Warning	NonLatch	All	The current value for the cumulative starts and or hours for the given compressor have been modified by a write override from TU in any running mode. The diagnostic will only appear in the Historic Alarms list.	Remote
Suction Refrigerant Pressure Sensor - xy	Cprsr	Immediate	Latch	All	Bad Sensor or LLID.	Remote
Suction Temperature Sensor	Circuit	Immediate	Latch	All	Bad Sensor or LLID.	Remote
Very Low Discharge Superheat - xy	Circuit	Normal	Latch	Any Running Mode	See Compressor Minimum Superheat Protection section in the Oil Flow Protection spec for specific criteria. Generally, this diagnostic indicates a likelihood of an evaporator carryover (flooded evap) condition.	Remote
Very Low Evaporator Refrigerant Pressure - xy	Chiller	Immediate	Latch	All	The respective circuit's evaporator pressure dropped below 80% of the current Low Evap Refrigerant Press Cutout setting (see above) or 8 psia, whichever is less, regardless of the running state of the circuit's compressor. Note: Unlike previous products, even if the circuit associated with the suction pressure sensor is locked out, it will not defeat the protection afforded by this diagnostic.	Local

Communication Diagnostics

Table 33. Communication diagnostics

Diagnostic Name	Affects Target	Severity	Persistence	Active Modes [Inactive Modes]	Criteria	Reset Level
Comm Loss: Fan Inverter Fault	Circuit (fan control)	Special Mode (or in single fan deck: Circuit Immediate shutdown)	Latch (or in single fan deck: Latch)	All	Continual loss of communication between the MP and the Functional ID has occurred for a 30-second period. Operate the remaining fans as fixed speed fan deck. For single fan deck configurations, this diagnostic causes a latching circuit shutdown	Remote
Comm Loss: % RLA Indication Output(Vdc)	Chiller	Warning	Latch	All	Continual loss of communication between the MP and the Functional ID has occurred for a 30-second period.	Remote
Comm Loss: Compressor Discharge Rfght Temperature - xy	Cprsr	Normal	Latch	All	Continual loss of communication between the MP and the Functional ID has occurred for a 30-second period.	Remote

Table 33. Communication diagnostics (continued)

Diagnostic Name	Affects Target	Severity	Persistence	Active Modes [Inactive Modes]	Criteria	Reset Level
Comm Loss: Cond Head Press Cntrl Output	Chiller	Immediate	Latch	All	Continual loss of communication between the MP and the Functional ID has occurred for a 30-second period.	Remote
Comm Loss: Cond Refrigerant Pressure Output	Chiller	Immediate	Latch	All	Continual loss of communication between the MP and the Functional ID has occurred for a 30-second period.	Remote
Comm Loss: Cond Water Pump Analog Output	Chiller	Normal	Latch	All	Continual loss of communication between the MP and the Functional ID has occurred for a 30-second period.	Remote
Comm Loss: Condenser Entering Water Temperature	Chiller	Info and Special Action	Latch	All	Continual loss of communication between the MP and the Functional ID has occurred for a 30-second period. If chiller running, and condenser water regulating valve option installed, force valve to 100% flow.	Remote
Comm Loss: Condenser Leaving Water Temperature	Chiller	Info and Special Action	Latch	All	Continual loss of communication between the MP and the Functional ID has occurred for a 30-second period. If Chiller is running in the heat mode of operation – normal shutdown, otherwise, informational only. Discontinue Min Capacity Limit forced cprsr loading due to Low DP in subsequent start-ups.	Remote
Comm Loss: Condenser Refrigerant Pressure	Circuit	Immediate	Latch	All	Continual loss of communication between the MP and the Functional ID has occurred for a 30-second period.	Remote
Comm Loss: Condenser Water Flow Switch	Chiller	Immediate	Latch	All	Continual loss of communication between the MP and the Functional ID has occurred for a 30-second period.	Remote
Comm Loss: Condenser Water Pump Relay	Chiller	Normal	Latch	All	Continual loss of communication between the MP and the Functional ID has occurred for a 30-second period.	Remote
Comm Loss: Electronic Expansion Valve - X	Circuit	Normal	Latch	All	Continual loss of communication between the MP and the EXV Step Status has occurred for a 30-second period, OR EXV Steps Maximum Position has not been received. If EXV Steps Maximum Position has not been received, MP will periodically request EXV Steps Maximum Position, since it is only transmitted upon request.	Remote
Comm Loss: Emergency Stop Feedback Input	Chiller	Normal	Latch	All	Continual loss of communication between the MP and the Functional ID has occurred for a 30-second period.	Remote

Table 33. Communication diagnostics (continued)

Diagnostic Name	Affects Target	Severity	Persistence	Active Modes [Inactive Modes]	Criteria	Reset Level
Comm Loss: Energy Meter Pulse Input	Chiller	Warning	Latch	All	Continual loss of communication between the MP and the Functional ID has occurred for a 30-second period.	Remote
Comm Loss: Energy Meter X	Chiller	Warning	Latch	All	Continual loss of communication between the MP and the Power Meter has occurred for a 30-second period.	Remote
Comm Loss: Evap Rfght Liquid Level - Cktx	Circuit	Normal	Latch	All	Continual loss of communication between the MP and the Functional ID has occurred for a 30-second period.	Remote
Comm Loss: Evaporator Entering Water Temperature	Chiller	Normal	Latch	All	Continual loss of communication between the MP and the Functional ID has occurred for a 30-second period. Note: Entering Water Temp Sensor is used in EXV pressure control as well as ice making and CHW reset, so it must cause a unit shutdown even if Ice or CHW reset is not installed.	Remote
Comm Loss: Evaporator Leaving Water Temperature	Chiller	Normal	Latch	All	Continual loss of communication between the MP and the Functional ID has occurred for a 30-second period.	Remote
Comm Loss: Evaporator Water Flow Switch	Chiller	Immediate	Latch	All	Continual loss of communication between the MP and the Functional ID has occurred for a 30-second period.	Remote
Comm Loss: Evaporator Water Pump Relay	Chiller	Normal	Latch	All	Continual loss of communication between the MP and the Functional ID has occurred for a 30-second period.	Remote
Comm Loss: Ext Noise Reduction Request	Chiller	Warning	Latch	All	Continual loss of communication between the MP and the Functional ID has occurred for a 30-second period.	Remote
Comm Loss: External Auto/ Stop	Chiller	Normal	Latch	All	Continual loss of communication between the MP and the Functional ID has occurred for a 30-second period.	Remote
Comm Loss: External Chilled Water Setpoint	Chiller	Special Action	Latch	All	Continual loss of communication between the MP and the Functional ID has occurred for a 30-second period. Chiller shall discontinue use of the External Chilled Water Setpoint source and revert to the next higher priority for setpoint arbitration	Remote
Comm Loss: External Ckt Lockout	Circuit	Special Action	Latch	All	Continual loss of communication between the MP and the Functional ID has occurred for a 30-second period. MP will nonvolatile hold the lockout state (enabled or disabled) that was in effect at the time of comm loss.	Remote

Table 33. Communication diagnostics (continued)

Diagnostic Name	Affects Target	Severity	Persistence	Active Modes [Inactive Modes]	Criteria	Reset Level
Comm Loss: External Demand Limit Setpoint	Chiller	Special Action	Latch	All	Continual loss of communication between the MP and the Functional ID has occurred for a 30-second period. Chiller shall discontinue use of the External Demand limit setpoint and revert to the next higher priority for Demand Limit setpoint arbitration.	Remote
Comm Loss: External Hot Water Command	Chiller	Warning	Latch	All	Continual loss of communication between the MP and the Functional ID has occurred for a 30-second period. Chiller shall discontinue use of the External Chilled Water Setpoint source and revert to the next higher priority for setpoint arbitration	Remote
Comm Loss: External Ice Building Command	Chiller	Special Action	Latch	All	Continual loss of communication between the MP and the Functional ID has occurred for a 30-second period. Chiller shall revert to normal (non-ice building) mode regardless of last state.	Remote
Comm Loss: Fan Control Relays - x	Circuit	Normal	Latch	All	Continual loss of communication between the MP and the Functional ID has occurred for a 30-second period.	Remote
Comm Loss: Fan Inverter Speed Command	Circuit (fan control)	Special Mode (or in single fan deck: Circuit Immediate shutdown)	Latch (or in single fan deck: Latch)	All	Continual loss of communication between the MP and the Functional ID has occurred for a 30-second period. Operate the remaining fans as fixed speed fan deck. For single fan deck configurations, this diagnostic causes a latching circuit shutdown	Remote
Comm Loss: High Pressure Cutout Switch - xy	Cprsr	Normal	Latch	All	Continual loss of communication between the MP and the Functional ID has occurred for a 30-second period.	Remote
Comm Loss: Ice Building Status Relay	Chiller	Special Action	Latch	All	Continual loss of communication between the MP and the Functional ID has occurred for a 30-second period. Chiller shall revert to normal (non-ice building) mode regardless of last state.	Remote
Comm Loss: Local BAS Interface	Chiller	Warning	NonLatch	All	Continual loss of communication between the MP and the Functional ID has occurred for a 30-second period. Diagnostic is cleared when successful communication is established with the LonTalk LLID (LCIC)	Remote
Comm Loss: Mains Voltage Detection	Chiller	Warning	Latch	All	Continual loss of communication between the MP and the Functional ID has occurred for a 30-second period.	Remote
Comm Loss: Motor Winding Temperature 1, CprsrXY	Cprsr	Normal	Latch	All	Continual loss of communication between the MP and the Functional ID has occurred for a 30-second period.	Remote

Table 33. Communication diagnostics (continued)

Diagnostic Name	Affects Target	Severity	Persistence	Active Modes [Inactive Modes]	Criteria	Reset Level
Comm Loss: Motor Winding Temperature 2, CprsrXY	Cprsr	Normal	Latch	All	Continual loss of communication between the MP and the Functional ID has occurred for a 30-second period.	Remote
Comm Loss: Motor Winding Thermostat Compressor xA	Circuit	Normal	Latch	All	Continual loss of communication between the MP and the Functional ID has occurred for a 30-second period.	Remote
Comm Loss: Noise Reduction Request Relay	Chiller	Warning	Latch	All	Continual loss of communication between the MP and the Functional ID has occurred for a 30-second period.	Remote
Comm Loss: Oil Loss Level Sensor Input	Circuit	Normal	Latch	All	Continual loss of communication between the MP and the Functional ID has occurred for a 30-second period.	Remote
Comm Loss: Oil Pressure - xy	Cprsr	Immediate	Latch	All	Continual loss of communication between the MP and the Functional ID has occurred for a 30-second period.	Remote
Comm Loss: Oil Return Gas Pump Drain	Circuit	Normal	Latch	All	Continual loss of communication between the MP and the Functional ID has occurred for a 30-second period.	Remote
Comm Loss: Oil Return Gas Pump Fill	Circuit	Normal	Latch	All	Continual loss of communication between the MP and the Functional ID has occurred for a 30-second period.	Remote
Comm Loss: Oil Return Purge Valve -x	Circuit	Warning	Latch	All	Continual loss of communication between the MP and the Functional ID has occurred for a 30-second period.	Remote
Comm Loss: Outdoor Air Temperature	Chiller	Warning	Latch	All	Continual loss of communication between the MP and the Functional ID has occurred for a 30-second period. If the outdoor temperature is used for CHW reset, there shall be no CHW reset. Apply slew rates per Chilled Water Reset spec. If installed for low ambient lockout, there shall be no LA lockout imposed.	Remote
Comm Loss: Programmable Relay Board 1	Chiller	Warning	Latch	All	Continual loss of communication between the MP and the Functional ID has occurred for a 30-second period.	Remote
Comm Loss: Programmable Relay Board 2	Chiller	Warning	Latch	All	Continual loss of communication between the MP and the Functional ID has occurred for a 30-second period.	Remote

Table 33. Communication diagnostics (continued)

Diagnostic Name	Affects Target	Severity	Persistence	Active Modes [Inactive Modes]	Criteria	Reset Level
Comm Loss: Slide Valve Load - xy	Cprsr	Normal	Latch	All	Continual loss of communication between the MP and the Functional ID has occurred for a 30-second period.	Remote
Comm Loss: Slide Valve Unload - xy	Cprsr	Normal	Latch	All	Continual loss of communication between the MP and the Functional ID has occurred for a 30-second period.	Remote
Comm Loss: Starter Panel High Temperature Limit – Compressor 1A	Chiller	Info	Latch	All	Continual loss of communication between the MP and the Functional ID has occurred for a 30-second period.	Local
Comm Loss: Starter xy	Cprsr	Immediate	Latch	All	Continual loss of communication between the MP and the Functional ID has occurred for a 30-second period.	Local
Comm Loss: Step Load - xy	Cprsr	Normal	Latch	All	Continual loss of communication between the MP and the Functional ID has occurred for a 30-second period.	Remote
Comm Loss: Suction Refrigerant Pressure - xy	Cprsr	Immediate	Latch	All [Ckt/Cprsr lock out]	Continual loss of communication between the MP and the Functional ID has occurred for a 30-second period.	Remote
Comm Loss: Suction Temperature	Circuit	Normal	Latch	All	Continual loss of communication between the MP and the Functional ID has occurred for a 30-second period.	Remote



Wiring

The table below provides a list of field wiring diagrams, electrical schematics, and connection diagrams for RTWD units. Wiring diagrams can be accessed via e-Library. A laminated wiring diagram booklet is also shipped with each

unit. To determine the specific electrical characteristics of a particular chiller, refer to the nameplates mounted on the units.

Drawing		Description	
2311-5999	Sheet 1	Schematic - Wye-Delta Starter	Legend
	Sheet 2		Compressor - Ckt 1 (1A)
	Sheet 3		Compressor - Ckt 2 (2A)
	Sheet 4		Controls
	Sheet 5		Controls/LLID Bus
	Sheet 6		Controls/LLID Bus
2311-6096	Sheet 1	Schematic - X-line Starters	Legend
	Sheet 2		Compressor - Ckt 1 (1A)
	Sheet 3		Compressor - Ckt 2 (2A)
	Sheet 4		Controls
	Sheet 5		Controls/LLID Bus
	Sheet 6		Controls/LLID Bus
2311-6054	Sheet 1	Unit Component Location	Diagram
	Sheet 2		Legend/Notes
2311-6053	Sheet 1	Control Panel Component Location	Diagram
	Sheet 2		Legend
2311-6004	Sheet 1	Field Wiring	Diagram
	Sheet 2		Notes/Fuses
2311-6005	Sheet 1	Field Layout	Diagram
	Sheet 2		Notes



Log and Check Sheets

The following forms and check sheets are included for use with Trane start-up of RTWD chillers. Forms and check sheets are used, as appropriate, for installation completion verification before Trane start-up is scheduled, and for reference during the Trane start-up.

Where the form or check sheet also exists outside of this publication as standalone literature, the literature order number is also listed.

- Model RTWD Installation Completion Check Sheet and Request for Trane Service (RLC-ADF007*-EN)
- Chiller Log Sheet



Model RTWD Chiller Installation Completion Check Sheet and Request for Trane Service

Important: A copy of this completed form must be submitted to the Trane service agency that will be responsible for the start-up of the chiller. Start-up will NOT proceed unless applicable items listed in this form have been satisfactorily completed. See unit IOM RLC-SVX09*-EN for detailed installation instructions.

To: _____

Trane Service Office: _____

S.O. Number: _____

Serial Numbers: _____

Job/Project Name: _____

Address: _____

The following items are being installed and will be completed by: _____

Important: Start-up must be performed by Trane or an agent of Trane specifically authorized to perform start-up and warranty of Trane® products. Contractor shall provide Trane (or an agent of Trane specifically authorized to perform start-up) with notice of the scheduled start-up at least two weeks prior to the scheduled start-up.

Important: It is required that heaters are energized for a minimum of 24 hours prior to start-up. Therefore, chiller should have power for this amount of time before Trane Service arrives to do start-up.

Check boxes if the task is complete or if the answer is "yes".

1. Screw Chiller

- Installation meets foundation requirements
- In place and piped.
- Isolation pads or isolators installed.

2. Piping

- Chilled water piping connected to:
 - Evaporator
 - Air handling units
 - Pumps
 - Flow switch or flow proving device installed (if not factory provided)
 - Strainer installed and cleaned

- Drain and vents in both evaporator waterboxes are piped with shutoff valve, or plugs have been reinstalled.
- Condenser piping connected to:
 - Condenser
 - Pumps
 - Flow switch or flow proving device installed (if not factory provided)
 - Condenser water regulating valve
 - Cooling tower
 - Drain and vents in both condenser waterboxes are piped with shutoff valve, or plugs have been reinstalled.
- Make-up water connected to cooling water.
- Water supply connected to filling system
- Does unit have freeze inhibitor? If unit has freeze inhibitor:
 - Verify type and concentration correct per unit submittal
 - Calculate and record freeze point of the solution: _____

- Systems filled
- Pumps run, air bled from system
- Strainer installed in entering water piping (evaporator and condenser) and cleaned
- Relief valve ventilation piping installed

3. Flow balancing valves installed

- Leaving chilled water
- Leaving condenser water
- Proper porting to measure flow and balance

4. Gauges, thermometers, and air vents

- Installed on both sides of evaporator
- Installed on both sides of condenser and heat recovery condenser (as applicable)

5. Wiring

- Wire size per submittal and NEC 310-16
- Full power available
- External interlocks (flow switch, pumps auxiliary, etc.)
- Chilled water pump (connected and tested)
- Condenser water pump (connected and tested)
- Cooling tower fan rotation checked
- Separate power sources available for 220V water regulating valve, if selected
- 115 Vac power available for service tools as required
- All controls installed and connected

6. Testing

- Dry nitrogen available for pressure testing
- Trace gas amounts of appropriate refrigerant available for leak testing, if necessary

7. Unit Charging

- Refrigerant on job site if nitrogen charge option selected

8. Systems can be operated under load conditions
9. Heaters

- Energize oil separator and compressor heaters and verify they are operational using a temperature probe.
- If unit was factory charged (model number digit 45= 5 or 7), **energize heaters for 24 hours prior to start-up.**

Important: It is required that chiller heaters are energized for a minimum of 24 hours prior to start-up. Therefore, chiller should have power for this amount of time before Trane Service arrives to do start-up.

- If unit has nitrogen charge (model number digit 45 = 6 or 8), contact Trane Service for unit charging prior to start-up.

10. Equipment Room

- Does the equipment room have a refrigerant monitor/sensor capable of monitoring and alarming within the allowable exposure level of the refrigerant?
- Does the installation have properly placed and operating audible and visual refrigerant alarms?
- Does the equipment room have proper mechanical ventilation?
- If it is required by local code, is a self-contained breathing apparatus available?

11. Owner Awareness

- Does the owner have a copy of the SDS for refrigerant and oil?

Note: Additional time required to properly complete the start-up and commissioning, due to any incompleteness of the installation, will be invoiced at prevailing rates.

This is to certify that the Trane® equipment has been properly and completely installed, and that the applicable items listed above have been satisfactorily completed.

Important: It is required that the heaters are energized for a minimum of 24 hours prior to start-up. Therefore, the chiller should have power for this amount of time before Trane Service arrives to do start-up of the equipment.

Checklist completed by: _____

Signed: _____

Date: _____

In accordance with your quotation and our purchase order number _____, we will therefore require the presence of Trane service on this site, for the purpose of start-up and commissioning, by _____ (date).

Note: Minimum two-week advance notification is required to allow scheduling of the chiller start-up.

Additional Comments/Instructions:

Note: A copy of this completed form must be submitted to the Trane Service Office that will be responsible for start-up of chiller.



Log and Check Sheets

Chiller Log Sheet

Chiller Log Sheet				
Tab	Measurement	15 minutes	30 minutes	1 hour
Main				
	Chiller Mode			
	Evaporator Entering/Leaving Water Temperature			
	Condenser Entering/Leaving Water Temperature			
	Active Chiller Water Setpoint (°F)			
	Average Line Current (%RLA)			
	Active Demand Limit Setpoint (%RLA)			
	Software Type			
	Software Version			
Reports				
EVAPORATOR				
	Entering Water Temperature (°F)			
	Leaving Water Temperature (°F)			
	Saturated Refrigerant Temperature (°F)			
	Refrigerant Pressure (psia)			
	Approach Temperature (°F)			
	Water Flow Switch Status			
	EXV Position (%)			
	EXV Position Steps			
	Refrigerant Liquid Level (inch)			
CONDENSER				
	Entering Water Temperature (°F)			
	Leaving Water Temperature (°F)			
	Saturated Refrigerant Temperature (°F)			
	Refrigerant Pressure (psia)			
	Approach Temperature (°F)			
	Water Flow Switch Status			
	Head Pressure Control Command (%)			
COMPRESSOR 1				
	Starts			
	Run Time			
	System Refrigerant Differential Pressure (psid)			
	Oil Pressure (psia)			
	Refrigerant Discharge Temperature (°F)			
	Discharge Superheat (°F)			
	% RLA L1 L2 L3 (%)			



Log and Check Sheets

Chiller Log Sheet				
Tab	Measurement	15 minutes	30 minutes	1 hour
	Amps L1 L2 L3 (amps)			
	Volts AB BC CA			
COMPRESSOR 2				
	Starts			
	Run Time			
	System Refrigerant Differential Pressure (psid)			
	Oil Pressure (psia)			
	Refrigerant Discharge Temperature (°F)			
	Discharge Superheat (°F)			
	% RLA L1 L2 L3 (%)			
	Amps L1 L2 L3 (amps)			
	Volts AB BC CA			
Date:				
Technician:				
Owner:				

Chiller Settings		
Tab	Category	Setting
Settings		
CHILLER		
	Front Panel Water Setpoint (°F)	
	Front Panel Demand Limit Setpoint (°F)	
	Differential to Start (°F)	
	Differential to Stop (°F)	
	Setpoint Source	
FEATURE SETTINGS		
	Chilled Water Reset	
	Return Reset Ratio	
	Return Start Reset	
	Return Maximum Reset	
	Outdoor Reset Ratio	
	Outdoor Start Reset	
	Outdoor Maximum Reset	
MODE OVERRIDES		
	Evaporator Water Pump	
	Condenser Water Pump	
	Expansion Valve Control	
	Slide Valve Control	
	Service Pumpdown	



Log and Check Sheets

Chiller Settings		
Tab	Category	Setting
DISPLAY SETTINGS		
	Date Format	
	Date	
	Time Format	
	Time of Day	
	Keypad/Display Lockout	
	Display Units	
	Pressure Units	
	Language Selection	
Date:		
Technician:		
Owner:		

Trane - by Trane Technologies (NYSE: TT), a global innovator - creates comfortable, energy efficient indoor environments for commercial and residential applications. For more information, please visit trane.com or tranetechnologies.com.

Trane has a policy of continuous product and product data improvements and reserves the right to change design and specifications without notice. We are committed to using environmentally conscious print practices.

RLC-SVX09R-EN 22 Sep 2024
Supersedes RLC-SVX09Q-EN (September 2024)

©2024 Trane