

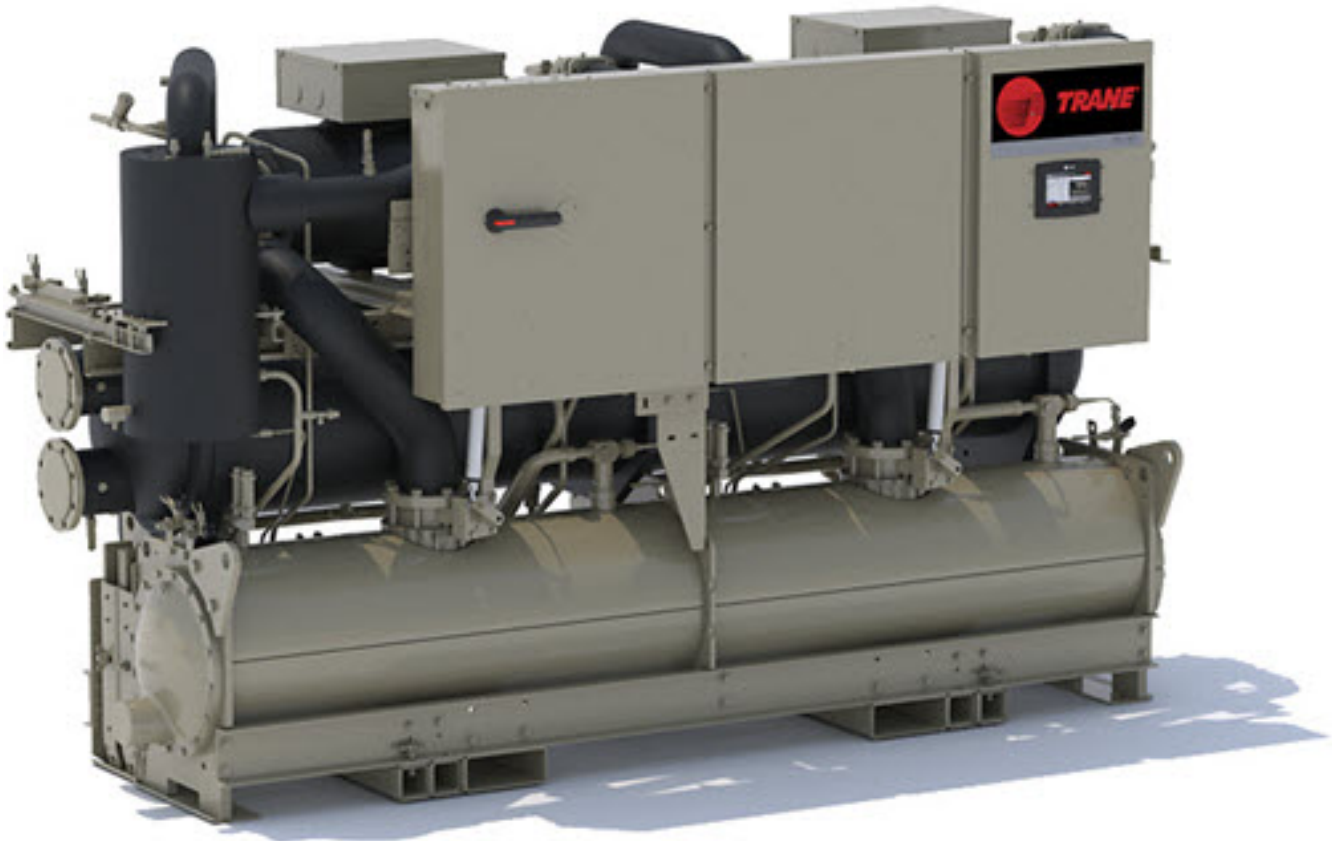

# Installation, Operation, and Maintenance

## **Series R® Heat Pump Chiller**

### Model RTZA



#### **▲ SAFETY WARNING**

Only qualified personnel should install and service the equipment. The installation, starting up, and servicing of heating, ventilating, and air-conditioning equipment can be hazardous and requires specific knowledge and training. Improperly installed, adjusted or altered equipment by an unqualified person could result in death or serious injury. When working on the equipment, observe all precautions in the literature and on the tags, stickers, and labels that are attached to the equipment.



# Introduction

Read this manual thoroughly before operating or servicing this unit.

## Warnings, Cautions, and Notices

Safety advisories appear throughout this manual as required. Your personal safety and the proper operation of this machine depend upon the strict observance of these precautions.

The three types of advisories are defined as follows:



Indicates a potentially hazardous situation which, if not avoided, could result in death or serious injury.



Indicates a potentially hazardous situation which, if not avoided, could result in minor or moderate injury. It could also be used to alert against unsafe practices.



Indicates a situation that could result in equipment or property-damage only accidents.

## Important Environmental Concerns

Scientific research has shown that certain man-made chemicals can affect the earth's naturally occurring stratospheric ozone layer when released to the atmosphere. In particular, several of the identified chemicals that may affect the ozone layer are refrigerants that contain Chlorine, Fluorine and Carbon (CFCs) and those containing Hydrogen, Chlorine, Fluorine and Carbon (HCFCs). Not all refrigerants containing these compounds have the same potential impact to the environment. Trane advocates the responsible handling of all refrigerants.

## Important Responsible Refrigerant Practices

Trane believes that responsible refrigerant practices are important to the environment, our customers, and the air conditioning industry. All technicians who handle refrigerants must be certified according to local rules. For the USA, the Federal Clean Air Act (Section 608) sets forth the requirements for handling, reclaiming, recovering and recycling of certain refrigerants and the equipment that is used in these service procedures. In addition, some states or municipalities may have additional requirements that must also be adhered to for responsible management of refrigerants. Know the applicable laws and follow them.

### **⚠ WARNING**

#### **Proper Field Wiring and Grounding Required!**

Failure to follow code could result in death or serious injury.

**All field wiring MUST be performed by qualified personnel. Improperly installed and grounded field wiring poses FIRE and ELECTROCUTION hazards. To avoid these hazards, you MUST follow requirements for field wiring installation and grounding as described in NEC and your local/state/national electrical codes.**

**⚠ WARNING****Personal Protective Equipment (PPE) Required!**

Failure to wear proper PPE for the job being undertaken could result in death or serious injury.

Technicians, in order to protect themselves from potential electrical, mechanical, and chemical hazards, **MUST** follow precautions in this manual and on the tags, stickers, and labels, as well as the instructions below:

- Before installing/servicing this unit, technicians **MUST** put on all PPE required for the work being undertaken (Examples; cut resistant gloves/sleeves, butyl gloves, safety glasses, hard hat/bump cap, fall protection, electrical PPE and arc flash clothing). **ALWAYS** refer to appropriate Safety Data Sheets (SDS) and OSHA guidelines for proper PPE.
- When working with or around hazardous chemicals, **ALWAYS** refer to the appropriate SDS and OSHA/GHS (Global Harmonized System of Classification and Labelling of Chemicals) guidelines for information on allowable personal exposure levels, proper respiratory protection and handling instructions.
- If there is a risk of energized electrical contact, arc, or flash, technicians **MUST** put on all PPE in accordance with OSHA, NFPA 70E, or other country-specific requirements for arc flash protection, **PRIOR** to servicing the unit. **NEVER PERFORM ANY SWITCHING, DISCONNECTING, OR VOLTAGE TESTING WITHOUT PROPER ELECTRICAL PPE AND ARC FLASH CLOTHING. ENSURE ELECTRICAL METERS AND EQUIPMENT ARE PROPERLY RATED FOR INTENDED VOLTAGE.**

**⚠ WARNING****Follow EHS Policies!**

Failure to follow instructions below could result in death or serious injury.

- All Trane personnel must follow the company's Environmental, Health and Safety (EHS) policies when performing work such as hot work, electrical, fall protection, lockout/tagout, refrigerant handling, etc. Where local regulations are more stringent than these policies, those regulations supersede these policies.
- Non-Trane personnel should always follow local regulations.

**⚠ WARNING****Cancer and Reproductive Harm!**

This product can expose you to chemicals including lead and bisphenol A (BPA), which are known to the State of California to cause cancer and birth defects or other reproductive harm. For more information go to [www.P65Warnings.ca.gov](http://www.P65Warnings.ca.gov).

**⚠ WARNING****Refrigerant under High Pressure!**

Failure to follow instructions below could result in an explosion which could result in death or serious injury or equipment damage.

System contains oil and refrigerant under high pressure. Recover refrigerant to relieve pressure before opening the system. See unit nameplate for refrigerant type. Do not use non-approved refrigerants, refrigerant substitutes, or refrigerant additives.



## Factory Warranty Information

Compliance with the following is required to preserve the factory warranty:

### All Unit Installations

Start-up **MUST** be performed by Trane, or an authorized agent of Trane, to **VALIDATE** this **WARRANTY**. Contractor must provide a two-week start-up notification to Trane (or an agent of Trane specifically authorized to perform start-up).

### Additional Requirements for Units Requiring Disassembly

When a new fully assembled chiller is shipped and received from our Trane manufacturing location, and, for any reason, it requires disassembly or partial disassembly — which could include but is not limited to the evaporator, condenser, control panel, compressor/motor, or any other components originally attached to the fully assembled unit — compliance with the following is required to preserve the factory warranty:

- Follow the *Disassembly Instructions* (RLC-SVN009\*-EN).
- Trane, or an agent of Trane specifically authorized to perform start-up and warranty of Trane® products, will perform or have direct onsite technical supervision of the disassembly and reassembly work.
- The installing contractor must notify Trane — or an agent of Trane specifically authorized to perform start-up and warranty of Trane products — two weeks in advance of the scheduled disassembly work to coordinate the disassembly and reassembly work.
- Start-up must be performed by Trane or an agent of Trane specifically authorized to perform start-up and warranty of Trane products as noted above.

Trane, or an agent of Trane specifically authorized to perform start-up and warranty of Trane® products, will provide qualified personnel and standard hand tools to perform the disassembly work at a location specified by the contractor. The contractor shall provide the rigging equipment such as chain falls, gantries, cranes, forklifts, etc. necessary for the disassembly and reassembly work and the required qualified personnel to operate the necessary rigging equipment.

## Copyright

This document and the information in it are the property of Trane, and may not be used or reproduced in whole or in part without written permission. Trane reserves the right to revise this publication at any time, and to make changes to its content without obligation to notify any person of such revision or change.

## Trademarks

All trademarks referenced in this document are the trademarks of their respective owners.

## Product Safety Information

This appliance is not intended for use by persons (including children) with reduced physical, sensory or mental capabilities, or lack of experience and knowledge, unless they have been given supervision or instruction concerning use of the appliance by a person responsible for their safety. Children should be supervised so they do not play with the appliance.

Maximum altitude of use 3,000 meters.

This appliance incorporates an earth connection for functional purposes only.

For installation only in locations not accessible to the general public.



# Table of Contents

- Model Number Information ..... 9
  - Nameplates ..... 9
    - Unit Nameplate ..... 9
    - Compressor Nameplate ..... 9
    - ASME Nameplate ..... 9
  - Model Number Coding System ..... 9
- Model Number Descriptions ..... 10
  - Unit Model Number ..... 10
  - Compressor Model Number ..... 12
- General Information ..... 13
  - Unit Description ..... 13
  - Accessory/Options Information ..... 13
  - General Data ..... 13
- Operating Principles ..... 15
  - Refrigeration Heating Cycle ..... 16
    - Overview ..... 16
    - Cycle Description ..... 16
  - Compressor ..... 17
  - Compressor Rotors ..... 17
  - Compressor Rotor Oil Supply ..... 17
  - Compressor Bearing Oil Supply ..... 17
  - Compressor Loading Sequence ..... 18
    - Fixed Sequence ..... 18
    - Balanced Start and Hours ..... 18
  - Oil System Operation ..... 19
    - Overview ..... 19
    - Oil Filter ..... 19
    - Oil Separator ..... 19
    - Oil Return System ..... 19
- Pre-Installation ..... 20
  - Inspection Checklist ..... 20
  - Unit Storage ..... 20
    - Pre-Installation ..... 20
  - Post-Installation with Refrigerant ..... 20
  - Installation Requirements and Contractor Responsibilities ..... 21
  - Unit Connections and Components ..... 23
    - Unit Connection Locations ..... 23
- Unit Dimensions and Weights ..... 27



## Table of Contents

---

Unit Dimensions . . . . .	27
Unit Center of Gravity . . . . .	30
Unit Clearances . . . . .	32
Unit Footprint Dimensions . . . . .	33
Weights . . . . .	34
Corner Weights . . . . .	34
Installation – Mechanical . . . . .	35
Location Requirements . . . . .	35
Noise Considerations . . . . .	35
Foundation . . . . .	35
Clearances . . . . .	35
Ventilation . . . . .	35
Heat Considerations . . . . .	35
Moving and Rigging . . . . .	36
Truck Transportation Tie-Downs . . . . .	37
Forklift Move . . . . .	38
Overhead Lift . . . . .	38
Dolly Move . . . . .	39
Unit Isolation and Leveling . . . . .	43
Water Piping . . . . .	45
Unit System Level Piping . . . . .	45
Field-Installed Components . . . . .	46
Water Isolation Valve . . . . .	47
Thermometer . . . . .	47
Pipe Strainer . . . . .	47
Water Pressure Relief Valves . . . . .	47
Reversing Waterboxes . . . . .	49
Waterbox Drain and Vents . . . . .	51
Pressure Transducer . . . . .	51
Water Regulating Valve . . . . .	52
Pressure Drop Curves . . . . .	53
Water Treatment . . . . .	54
Low Evaporator Refrigerant Cutout, Percent Glycol Requirements . . . . .	54
Refrigerant Relief Valve Venting . . . . .	55
Summary of Relief Valves . . . . .	56
Installation – Electrical . . . . .	57
General Recommendations . . . . .	57
Installer-Supplied Components . . . . .	57
Power Supply Wiring . . . . .	57
Control Power Supply . . . . .	58
Interconnecting Wiring . . . . .	58
Condenser and Chilled Water Pump Control . . . . .	58

Alarm and Status Relay Outputs (Programmable Relays) . . . . .	59
Relay Assignments . . . . .	60
Low Voltage Wiring . . . . .	61
Building Automation Systems . . . . .	63
BACnet® Building Automation Control Network . . . . .	63
Modbus® Automation Control Network . . . . .	63
LonTalk® Building Automation Systems . . . . .	63
Controls . . . . .	64
Symbio 800 . . . . .	64
AdaptiView Display . . . . .	64
Tracer TU . . . . .	64
Pre-Start . . . . .	66
Start-up and Shutdown . . . . .	67
Temporary Shutdown and Restart . . . . .	67
Extended Unit Shutdown . . . . .	67
Seasonal Unit Start-Up Procedure . . . . .	67
Sequence of Operation . . . . .	68
Power-up to Starting . . . . .	68
Stopped to Starting . . . . .	69
Normal Shutdown to Stopped . . . . .	70
RTZA-Specific Electrical Devices . . . . .	70
Suction Valve . . . . .	70
Oil Return Valve . . . . .	71
Differential Pressure Correction . . . . .	71
Discharge Superheat Valve . . . . .	72
Evaporator Shell Pressure Transducers . . . . .	72
High Condenser Water Temperature Cutout . . . . .	72
Water Flow Measurement Pressure Transducers . . . . .	73
Flow Calibration . . . . .	73
Maintenance . . . . .	80
Overview and Maintenance Checks . . . . .	80
Weekly Maintenance and Checks . . . . .	80
Monthly Maintenance and Checks . . . . .	80
Annual Maintenance . . . . .	80
Refrigerant and Oil Lab Analysis Schedule . . . . .	81
Scheduling Other Maintenance . . . . .	81
Heat Exchanger Maintenance . . . . .	82
Condenser Cleaning . . . . .	82
Lubrication System . . . . .	89
Compressor Oil . . . . .	89
Compressor Oil Removal . . . . .	89



## Table of Contents

---

Oil Charging . . . . .	89
Oil Filter Replacement . . . . .	89
Oil Sump Level Check . . . . .	90
Refrigerant System . . . . .	91
Evacuation and Dehydration . . . . .	91
Adding Refrigerant Charge . . . . .	91
Refrigerant Filter Replacement . . . . .	91
Refrigerant and Oil Charge Management . . . . .	92
Symptoms of Incorrect Charge . . . . .	92
Refrigerant Under-Charge . . . . .	92
Refrigerant Over-Charge . . . . .	92
Oil Over-Charge . . . . .	92
Oil Under-Charge . . . . .	93
Diagnostics . . . . .	94
General Diagnostics Information . . . . .	94
Starter Diagnostics . . . . .	94
Main Processor Diagnostics . . . . .	100
Communication Diagnostics . . . . .	117
Wiring . . . . .	124
Reference Documents . . . . .	125
Chiller Log Sheet . . . . .	126



# Model Number Information

## Nameplates

Unit nameplates are applied to the exterior of the control panel. A compressor nameplate is located on each compressor. When the unit arrives, compare all nameplate data with ordering, submittal, and shipping information.

### Unit Nameplate

The unit nameplate provides the following information:

- Model number
- Serial number
- Electrical requirements
- Operating charges (refrigerant and oil)
- Design pressures
- Refrigerant and oil type
- Installation, Operation, and Maintenance manual
- Wiring book

### Compressor Nameplate

The compressor nameplate provides the following information:

- Compressor model number
- Compressor serial number
- Compressor electrical characteristics
- Utilization range
- Compatible refrigerant

### ASME Nameplate

The ASME nameplate is different for the evaporators, condensers, oil separators, and condenser waterboxes.

The ASME nameplate provides the following information:

- Design pressures
- Design temperatures
- Serial number
- Year
- CRN

### Model Number Coding System

Model numbers are composed of numbers and letters that represent features of the equipment.

Each position, or group of positions, in the model number is used to represent a feature. Unit model number digits are selected and assigned in accordance with the definitions as listed in Model Number Descriptions chapter.



# Model Number Descriptions

## Unit Model Number

### Digit 1, 2, 3, 4 — Chiller Model

RTZA = Heat Pump Series R®

### Digit 5, 6, 7 — Unit Nominal Tonnage

195 = 195 Nominal Tons Heating

### Digit 8 — Unit Voltage

F = 460 Volt, 3-Phase

G = 575 Volt, 3-Phase

### Digit 9 — Manufacturing Plant

2 = Pueblo, USA

### Digit 10, 11 — Design Sequence

\*\* = Factory Assigned

### Digit 12 — Unit Type

2 = High Efficiency/Performance

### Digit 13 — Agency Listing

U = ETL Listed/Certified to CSA/Conforms to UL

### Digit 14 — Pressure Vessel Code

1 = ASME Pressure Vessel Code

C = Canadian Pressure Vessel Code

### Digit 15 — Unit Application

F = High Temperature Heat Pump

### Digit 16 — Pressure Relief Valve

1 = Single Relief Valve

2 = Dual Relief Valve with 3-Way Isolation Valve

### Digit 17 — Water Connection Type

B = Grooved Evap — Flanged Condenser

### Digit 18 — Evaporator Tubes

A = Internal and External Enhanced Evaporator Copper Tube

### Digit 19 — Evaporator Passes

2 = 2-Pass Evaporator

3 = 3-Pass Evaporator

### Digit 20 — Evaporator Water Side Pressure

A = 150 psi/10 Bar Evaporator Water Pressure

### Digit 21 — Evaporator Application

4 = High Heat

### Digit 22 — Condenser Tubes

B = Internally enhanced 90/10 CuNi fin

### Digit 23 — Condenser Water Side Pressure

1 = 150 psi/10 Bar Condenser Water Pressure

### Digit 24 — Compressor Starter Type

Y = Wye-Delta Closed Transition Starter

### Digit 25 — Incoming Power Line Connection

1 = Single Point Power Connection

### Digit 26 — Power Line Connection Type

D = Circuit Breaker

E = High Fault Rated Panel with Circuit Breaker

### Digit 27 — Under/Over Voltage Protection

0 = No Under/Over Voltage Protection

### Digit 28 — Unit Controller

2 = Symbio™ 800/TD-7

### Digit 29 — Remote Interface (Digital Comm)

0 = No Remote Digital Communication

5 = Modbus Communication Interface

B = BACnet® Interface (MS/TP)

P = BACnet® Interface (IP)

L = LonTalk® Interface

### Digit 30 — External Water and Demand Limit Setpoint

C = External Water and Demand Limit Setpoint 4-20 mA

D = External Water and Demand Limit Setpoint 2-10 Vdc

### Digit 31 — Ice Making

0 = No Ice Making

### Digit 32 — Programmable Relays

0 = No Programmable Relay

A = Programmable Relays

### Digit 33 — Condenser Refrigerant Pressure Output

0 = No Condenser Refrigerant Output

1 = Condenser Water Control Output

3 = Differential Pressure Output

### Digit 34 — Outdoor Air Temp Sensor

0 = No Outdoor Air Temp Sensor

### Digit 35 — Condenser Leaving Hot Water Temp Control

1 = Condenser Leaving Hot Water Temp Control

### Digit 36 — Power Meter

0 = No Power Meter  
E = Energy Meter

### Digit 37 — Motor Current Analog Output (% RLA)

0 = No Motor Current Analog Output

### Digit 38 — A/C Fan Control

0 = No Fan Controls (RTWD)

### Digit 39 — Low Ambient Fan Control

0 = No Low Ambient Fan Control Type

### Digit 40 — Installation Accessories

0 = Isolation Pad  
A = Neoprene Isolators

### Digit 41 — Flow Switch

5 = Factory-Installed Pressure Transducers evaporator/condenser 150 psi

### Digit 42 — 2-Way Water Regulating Valve

A = 3" 150 psi/88.9 mm 10.5 bar 115V  
B = 3" 150 psi/88.9 mm 10.5 bar 220V  
C = 4" 150 psi/114.3 mm 10.5 bar 115V  
D = 4" 150 psi/114.3 mm 10.5 bar 220V

### Digit 43 — Sound Reduction Package

0 = No Sound Reduction Package

### Digit 44 — Insulation

1 = Factory Insulation

### Digit 45 — Factory Charge

9 = Nitrogen Charge – R-1233zd(E) Field-Supplied

### Digit 46 — Base Rail Forklifting

C = Base Rail Forklift + Outrigger

### Digit 47 — Label and Literature Language

D = English  
B = Spanish (online only)  
E = French (online only)

### Digit 48 — Ship to Final Finisher

0 = None  
S = Ship to Final Finisher

### Digit 49 — Wireless Connectivity

0 = None  
A = Wi-Fi  
B = LTE Modem  
C = Air-Fi  
D = Wi-Fi and LTE Modem  
E = Wi-Fi and Air-Fi  
F = LTE Modem and Air-Fi  
G = Wi-Fi, LTE Modem, and Air-Fi

### Digit 51 — Number of Condenser Passes

2 = 2 pass condenser  
A = 2 pass low flow condenser

### Digit 50, 52, 53, 54, 55 — Special

0 = Not Used

### Digit 56 — Shipping Package

2 = Shrink Wrap  
3 = Skid + Shrink Wrap

### Digit 57 — Control Panel IP 20 Protection

0 = No IP 20 Protection of Control Panel

### Digit 58 — Pressure Gauges LP and HP

0 = Without Pressure Gauges

### Digit 59 — Performance Test

0 = No Performance Test

### Digit 60 — Evaporator Fluid Type

0 = Water  
1 = Calcium Chloride  
2 = Ethylene Glycol  
3 = Propylene Glycol  
4 = Methanol

### Digit 61 — Condenser Fluid Type

0 = Water  
B = Ethylene Glycol  
C = Propylene Glycol



## Model Number Descriptions

---

### Compressor Model Number

**Digit 1, 2, 3 — Model Compressor**

CHH = Positive displacement, helical rotary (twin screw) hermetic compressor

**Digit 4 — Compressor Type**

H = GP2.5 High Temperature

**Digit 5 — Economizer Port Detail**

A = Max Capacity

**Digit 6 — Compressor Frame Size**

N = Frame

**Digit 7 — Compressor Capacity**

6 = GP2.5 Larger Capacity

**Digit 8 — Motor Voltage**

H = 575–60–3

K = 460–60–3 (N6 Only)

**Digit 9 — Internal Relief**

K = 450 psid

**Digit 10, 11 — Design Sequence**

XX = Factory Assigned

**Digit 12 — Capacity Limit**

N = Standard capacity controls (no capacity limit)

**Digit 13, 14, 15 — Motor kW Rating**

134 = N6 60 Hz

**Digit 16 — Volume Ratio**

A = High Volume Ratio



# General Information

## Unit Description

The RTZA units are helical-rotary type, designed for indoor installation. The units have two independent refrigerant circuits, with one compressor per circuit. The RTZA units are packaged with an evaporator and condenser, control panel, oil coolers, electronic expansion valves, interconnecting piping, and safety devices.

**Note:** Each unit is completely assembled in a hermetic package that is factory-piped, wired, leak-tested, dehydrated, nitrogen-charged, and tested for proper control operations prior to shipment.

The water inlet and outlet pipe openings are covered for shipment. The RTZA model features Trane's exclusive Adaptive Control logic with heat pump controls. It monitors the control variables that govern the operation of the heat pump unit. Adaptive Control logic can correct these variables, when necessary, to optimize operational efficiencies and avoid heat pump shut down while continuing to produce hot water.

Compressor unloaders are solenoid-actuated. Each refrigerant circuit is provided with a filter, sight glass, electronic expansion valve, and charging valves.

The evaporator and condenser are manufactured in accordance with ASME standards. The condenser, compressor, compressor discharge lines, separator, compressor suction pipe, and liquid level assembly are fully-insulated. Both the evaporator and condenser are equipped with a water drain and vent connections.

The unit is designed to provide condenser leaving water temperatures from 160.1°F to 210°F from the condenser in conjunction with leaving evaporator water temperatures between 80°F and 120°F.

## Accessory/Options Information

Check all the accessories and optional loose parts which are shipped with the unit against the original order. Included in these items will be water vessel drain plugs, rigging diagrams, electrical diagrams, service literature, isolators, flow switches, external water valves, and sensor probes, which are placed inside the control panel and/or starter panel for shipment.

## General Data

Table 1. RTZA general data

Description	Units	Value
<b>Compressor</b>		
Size (Ckt1/Ckt2)		N6E2HT/N6E2HT
<b>Evaporator</b>		
<b>2 Pass Arrangement</b>		
Water Connection Size	NPS	6
	mm	150
Water Storage	Gal	31.8
	L	120.3
Minimum Flow	GPM	239
	L/s	15.1
Maximum Flow	GPM	877
	L/s	55.3
<b>3 Pass Arrangement</b>		
Water Connection Size	NPS	4
	mm	100
Water Storage	Gal	31
	L	117.5



## General Information

**Table 1. RTZA general data (continued)**

Description	Units	Value
Minimum Flow	GPM	159
	L/s	10
Maximum Flow	GPM	585
	L/s	36.9
<b>Condenser</b>		
<b>2 Pass Arrangement</b>		
Water Connection Size	NPS	5
	mm	127
Water Storage	Gal	39
	L	148
Minimum Flow	GPM	167
	L/s	10.5
Maximum Flow	GPM	890
	L/s	56.1
<b>2 Pass Arrangement (Low Flow)</b>		
Water Connection Size	NPS	5
	Mm	127
Water Storage	Gal	31.1
	L	117.7
Minimum Flow	GPM	165
	L/s	10.4
Maximum Flow	GPM	670
	L/s	42.3
<b>General Unit</b>		
Refrigerant Type		R-1233zd(E)
# Refrigerant Circuits		2
Refrigerant Charge	lb	180.8/180.8
	kg	82/82
Oil Type		Calumet Sontex 500-LE
Oil Charge	qt	9.5/9.5
	L	9
Nitrogen Charge (as shipped condition)	psi	15-20

# Operating Principles

See Figure 2, p. 15 for basic piping and instrumentation, including major components, valves, service ports, and sensors.

Figure 1. Piping and instrumentation legend

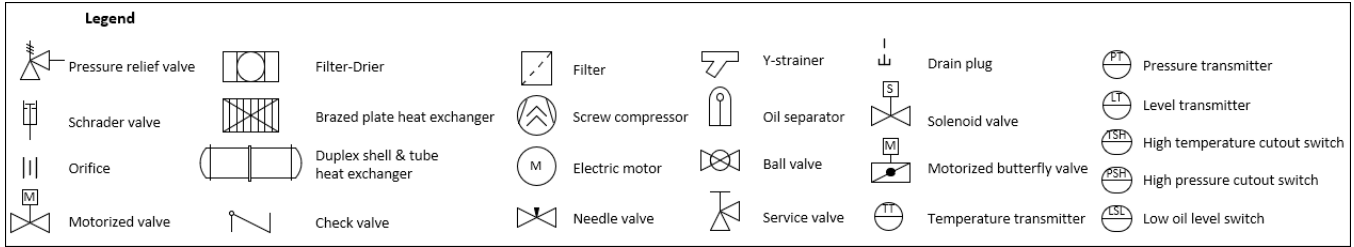
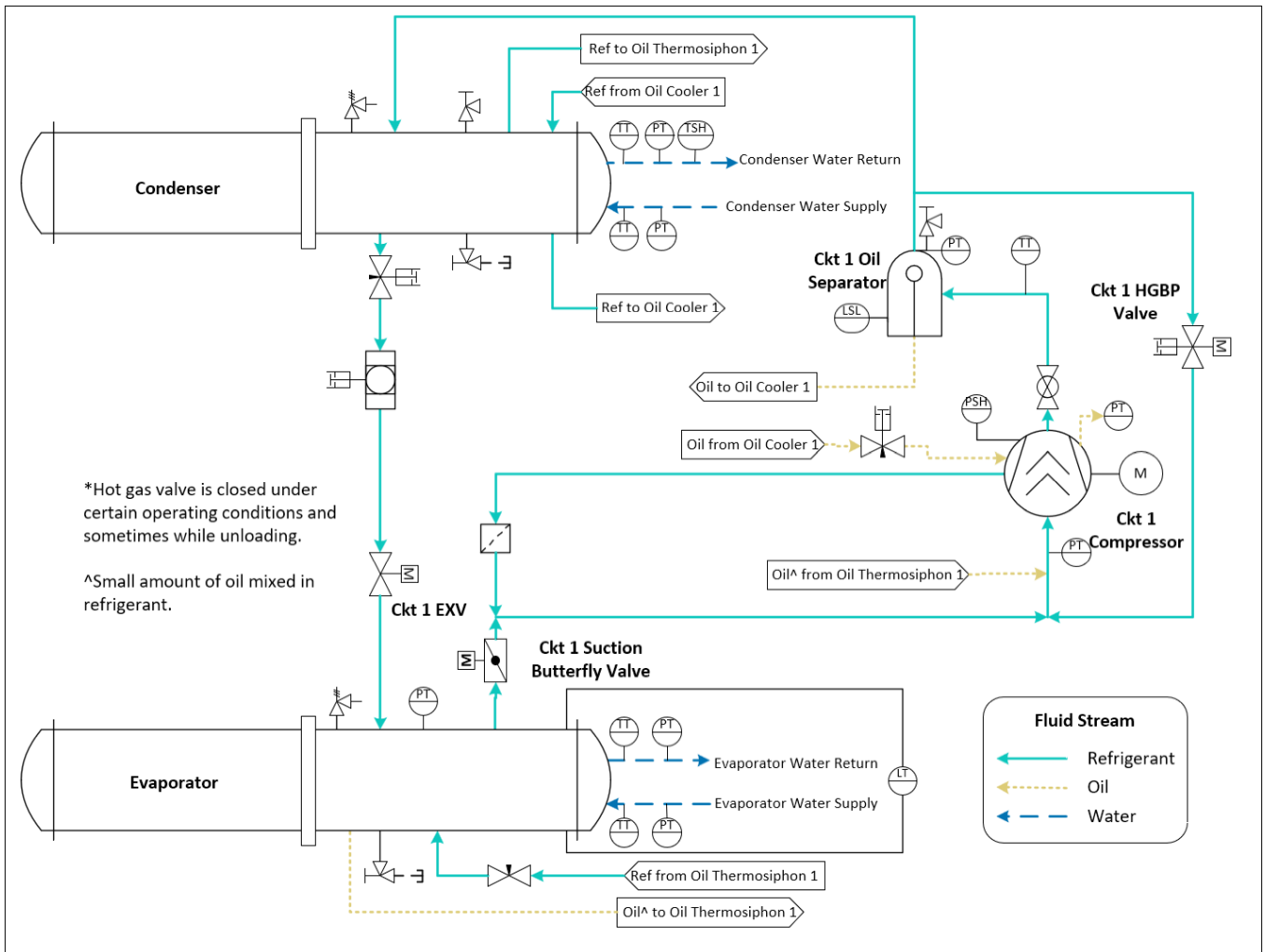

Figure 2. Piping and instrumentation system



## Refrigeration Heating Cycle

### Overview

The refrigeration cycle of the Series R® heat pump is conceptually similar to other Trane chiller products. It makes use of a shell-and-tube evaporator design with refrigerant evaporating on the shell side and water flowing inside tubes with enhanced surfaces.

The compressor is a twin-rotor helical rotary type. It uses a suction gas-cooled motor that operates at lower motor temperatures under continuous full and part-load operating conditions. An oil management system provides an almost oil-free refrigerant to the shells to maximize heat transfer performance, while providing lubrication and rotor sealing to the compressor. The lubrication system confirms long compressor life and contributes to quiet operation.

Refrigerant is condensed in a shell-and-tube heat exchanger where refrigerant is condensed on the shell side and water flows internally in the tubes.

Refrigerant is metered through the flow system using an electronic expansion valve, that maximizes heat pump efficiency at part load.

A unit-mounted starter and control panel is provided with every heat pump. Microprocessor-based unit control modules provide for accurate chilled water control as well as monitoring, protection, and adaptive limit functions. The adaptive nature of the controls intelligently prevents the heat pump from operating outside of its limits, or compensates for unusual operating conditions, while keeping the heat pump running rather than simply tripping due to a safety concern. If an issue occurs, diagnostic messages assist the operator.

### Cycle Description

The refrigeration cycle for the RTZA can be described using the pressure-enthalpy diagram shown below. Key State Points are indicated on the below figure and referenced in the information below.

**Figure 3. Pressure enthalpy curve**

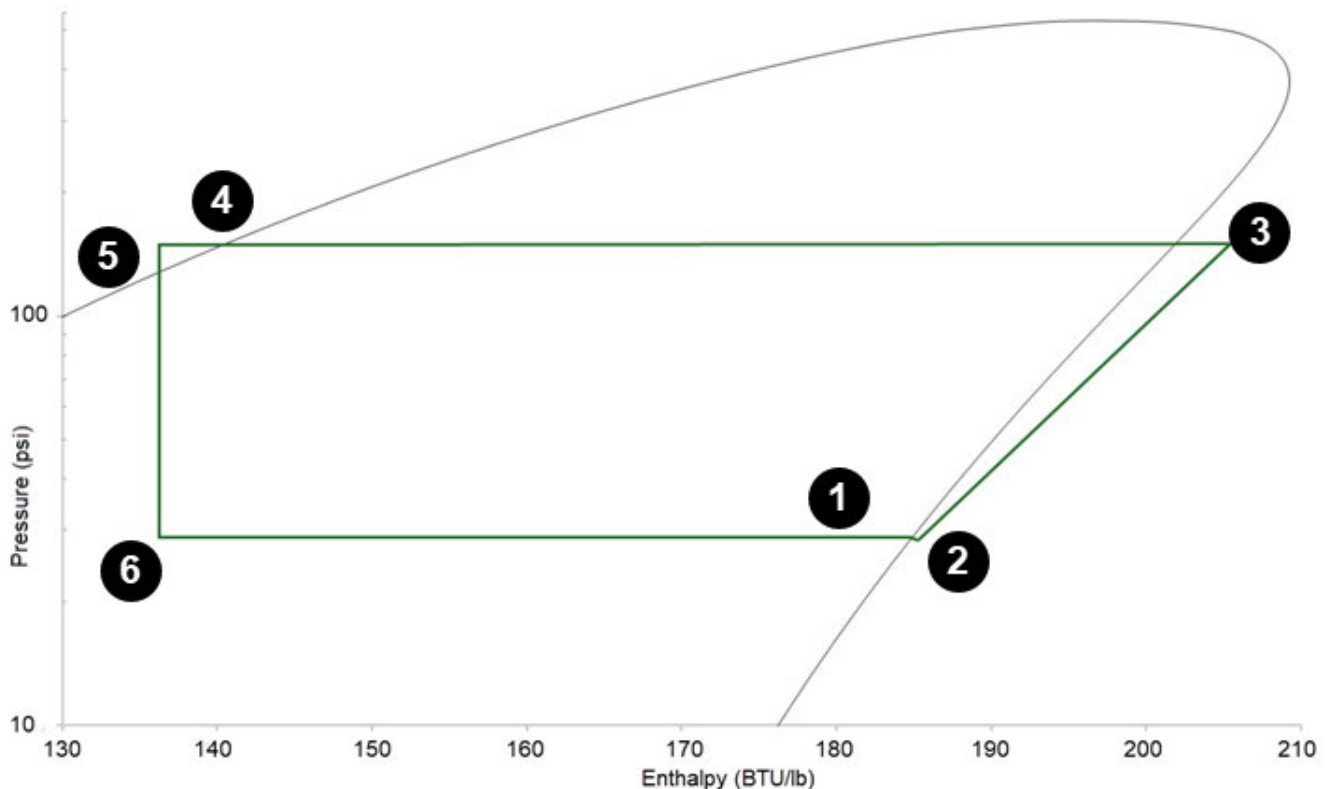

Evaporation of refrigerant occurs in the evaporator. A metered amount of refrigerant liquid enters a distribution system in the evaporator shell and is then distributed to the tubes in the evaporator tube bundle. The refrigerant absorbs heat and vaporizes as it cools the water flowing through the evaporator tubes. Refrigerant leaves the evaporator as saturated vapor (State Pt. 1).

The refrigerant exits the Suction Valve at State Pt. 2. The pressure drop across the valve results in additional discharge superheat.

The refrigerant vapor generated in the evaporator flows to the suction end of the compressor, where it enters the motor compartment of the suction-gas-cooled motor. The refrigerant flows across the motor, providing the necessary cooling, then enters the compression chamber. Refrigerant is compressed in the compressor to discharge pressure conditions. Simultaneously, lubricant is injected into the compressor for two purposes: (1) to lubricate the rolling element bearings, and (2) to seal the very small clearances between the compressor's twin rotors. Immediately following the compression process, the lubricant and refrigerant are effectively divided using an oil separator.

The oil-free refrigerant vapor enters the condenser at State Pt. 3. The lubrication and oil management issues are discussed in more detail in the compressor description and oil management sections that follow.

A discharge baffle within the condenser shell distributes the compressed refrigerant vapor evenly across the condenser tube bundle. Cooling tower water, circulating through the condenser tubes, absorbs heat from this refrigerant and condenses it.

As the refrigerant enters the bottom of the condenser (State Pt. 4), it enters an integral sub-cooler where additional heat is removed before traveling to the electronic expansion valve (State Pt. 5). The pressure drop created by the expansion process vaporizes a portion of the liquid refrigerant. The resulting mixture of liquid and gaseous refrigerant then enters the Evaporator Distribution System.

During State Pt. 6, the flash gas from the expansion process is internally routed to compressor suction, while the liquid refrigerant is distributed over the tube bundle in the evaporator.

The chiller maximizes the evaporator heat transfer performance while minimizing the refrigerant charge requirements. This is accomplished by metering the liquid refrigerant flow to the evaporator's distribution system using the electronic expansion valve. A relatively low liquid level is maintained in the evaporator shell, which contains a bit of surplus refrigerant liquid and accumulated lubricant. A liquid level measurement device monitors this level and provides feedback information to the unit controller, which commands the electronic expansion valve to reposition when necessary. If the refrigerant level rises, the expansion valve closes slightly, and if the level is dropping, the valve opens slightly such that a steady level is maintained.

## Compressor

A two-pole, hermetic, induction motor (3600 rpm at 60 hz, 3000 rpm at 50hz) directly drives the compressor rotors. The motor is cooled by suction refrigerant gas from the evaporator as it is routed back to the compressor rotors.

## Compressor Rotors

Two rotors – referred to as male and female - provide compression (see [“Compressor Bearing Oil Supply,” p. 17](#)). The male rotor is attached to, and driven by, the motor. The female rotor is, in turn, driven by the male rotor. Separately housed bearing sets are provided at each end of both rotors.

## Compressor Rotor Oil Supply

Oil flows through this circuit directly from the oil filter, through the oil control valve, to the top of the compressor rotor housing where it is injected along the top of the rotors. In addition to lubricating the rotors, the oil seals clearance spaces between the rotors and the compressor housing.

## Compressor Bearing Oil Supply

Oil is injected into the bearing housings located at each end of both rotors. Each bearing housing is vented to compressor suction, so oil leaving the bearings returns through the compressor rotors to the oil separator.

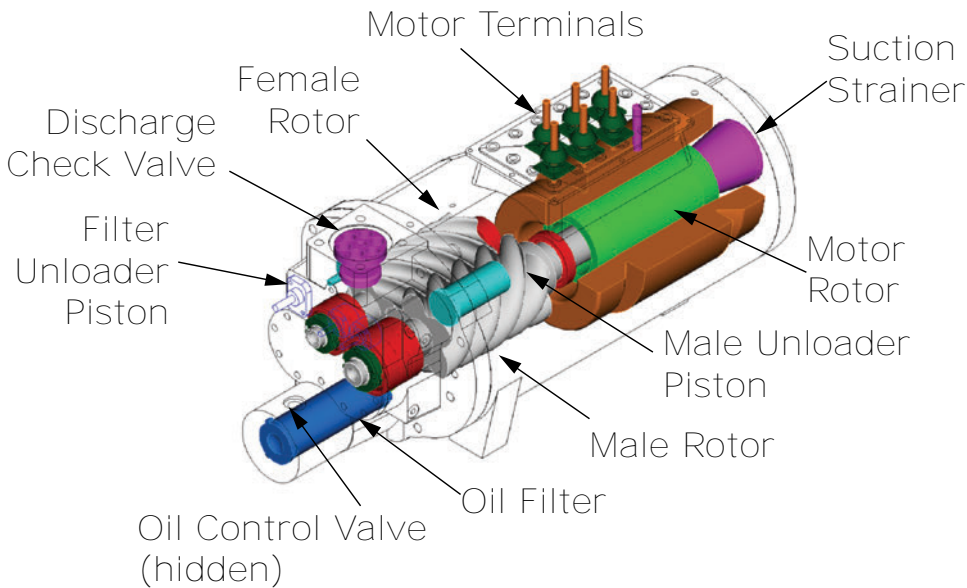
**Figure 4. RTZA compressor**

## Compressor Loading Sequence

Two loading sequences are available: Fixed Sequence or Balanced Start and Hours.

### Fixed Sequence

When Balanced Starts and Hours is disabled, the controls will operate with Fixed Sequence compressor loading. The lead compressor will start first on a command for cooling, unless it is locked out. Compressors will be unstepped and stopped in reverse order.

### Balanced Start and Hours

When Balanced Starts and Hours option is enabled, the controls will start the compressor with the lowest Start Bid, defined as:

$$\text{Compressor X Start Bid} = (\# \text{ of Starts for Compressor X}) + (\text{Accumulated Running hours for Compressor X} / 10)$$

If the compressor with the lowest Start Bid is unavailable due to a circuit lockout, circuit diagnostic, or compressor diagnostic, the compressor with the next lowest Start Bid will be started.

When compressors are running, and demand is decreased, the compressors unstage or turn off in order of priority as follows:

1. Any compressor running at minimum load.
2. The compressor with the greatest hours.

---

## Oil System Operation

### Overview

Oil that collects in the bottom of the oil separator is at condensing pressure during compressor operation; therefore, oil is constantly moving to lower pressure areas. As the oil leaves the separator, it passes through the oil cooler (if installed). It then goes through the service valve and filter. At this point it travels through the oil control valve. Then it provides oil injection and bearing lubrication. If the compressor stops for any reason, the oil control valve closes, isolating the oil charge in the separator and oil cooler during off periods. The oil control valve is a pressure activated valve. Discharge pressure off the rotors, that is developed when the compressor is on, causes the valve to open.

The helical rotary compressor is a positive displacement device. The refrigerant from the evaporator is drawn into the suction opening at the end of the motor barrel, through a suction strainer screen, across the motor, and into the intake of the compressor rotor section. The gas is then compressed and discharged directly into the discharge line.

There is no physical contact between rotors and compressor housing. Rotors contact each other at the point where the driving action between male and female rotors occurs. Oil is injected along top of compressor rotor section, coating both rotors and compressor housing interior. Although this oil does provide rotor lubrication, its primary purpose is to seal the clearance spaces between rotors and compressor housing.

A positive seal between these internal parts enhances compressor efficiency by limiting leakage between the high pressure and low pressure cavities.

### Oil Filter

Each compressor is equipped with a replaceable element oil filter. The filter removes any impurities that could foul the solenoid valve orifices and compressor internal oil supply galleries. This also prevents excessive wear of compressor rotor and bearing surfaces.

### Oil Separator

The oil separator consists of a vertical tube, joined at the top by the refrigerant discharge line from the compressor. This causes the refrigerant to swirl in the tube and throws the oil to the outside, where it collects on the walls and flows to the bottom. The compressed refrigerant vapor, stripped of oil droplets, exits out the top of the oil separator and is discharged into the condenser.

### Oil Return System

Despite the high efficiency of the oil separators, a small amount of oil migrates to the condenser, and eventually end up in the evaporator. This oil must be recovered and returned to the oil separator. The function of oil return is accomplished by a passive thermosyphon system. One side of the thermosyphon Brazed Plate Heat Exchanger (BPHE) is warmed by a small amount of condenser gas. Oil-rich refrigerant from the evaporator is fed through the other side of the BPHE and is vaporized because of the heat applied. The high-velocity refrigerant gas then carries the oil back to the compressor.



# Pre-Installation

## Inspection Checklist

- Verify if the unit is correct and properly equipped when delivered. Compare the information on the unit nameplate with the ordering and submittal information.
- Inspect all exterior components for visible damage. Report any apparent damage or material shortage to the carrier and make a **unit damage** notation on the carrier's delivery receipt. Specify the extent and type of damage found and notify the appropriate Trane Sales Office.

**Important:** Do not proceed with installation of a damaged unit without sales office approval.

To protect against loss due to damage incurred in transit, complete the following checklist upon receipt of the unit.

- Inspect the individual pieces of the shipment before accepting the unit. Check for obvious damage to the unit or packing material.
- Inspect the unit for concealed damage as soon as possible after delivery and before it is stored. Concealed damage must be reported within 15 days.
- Stop unpacking the shipment, if concealed damage is discovered. Do not remove damaged material from the receiving location. Take photos of the damage, if possible. The owner must provide reasonable evidence that the damage did not occur after delivery.
- Notify the carrier's terminal of the damage immediately, by phone and by mail. Request an immediate, joint inspection of the damage with the carrier and the consignee.
- Notify the Trane sales representative and arrange for repair. Do not repair the unit, however, until damage is inspected by the carrier's representative.

## Unit Storage

### Pre-Installation

RTZA units will be nitrogen charged to 15 psig -0/+5psi at the manufacturing location. To store the chiller for more than one month prior to installation, observe the following precautions:

- Do not remove the protective full unit shrink wrap bag.
- Store the chiller in a dry, secure area. Ambient temperature range should be maintained from -20°F to 158°F.
- Deploy the anti-tip device (see “Dolly Move,” p. 39).
- At least every three months, attach a gauge and manually check the pressure in the refrigerant circuit. If the nitrogen pressure is below 10 psi, call a qualified service organization and the appropriate Trane sales office.

### Post-Installation with Refrigerant

Once a unit is installed, retains refrigerant, but is turned off then ambient temperature should be maintained above 65°F. If the ambient air temperature is allowed below 65°F then the RTZA unit will enter a vacuum state due to the low pressure refrigerant and potentially allow non-condensibles to enter the refrigerant system.

To prevent this, the following are options:

- Monitor and maintain ambient air temperature above 65°F.
- Apply a heat strip to the condenser to elevate the units temperature
- Remove refrigerant
- Do nothing and accept an elevated risk of non-condensibles entering the refrigeration system.
- Flow warm water thru the unit
- Install purge equipment on each refrigerant circuit. The purge inlet and outlet connection ports should be made as shown in the image below:

**Figure 5. Purge access ports**

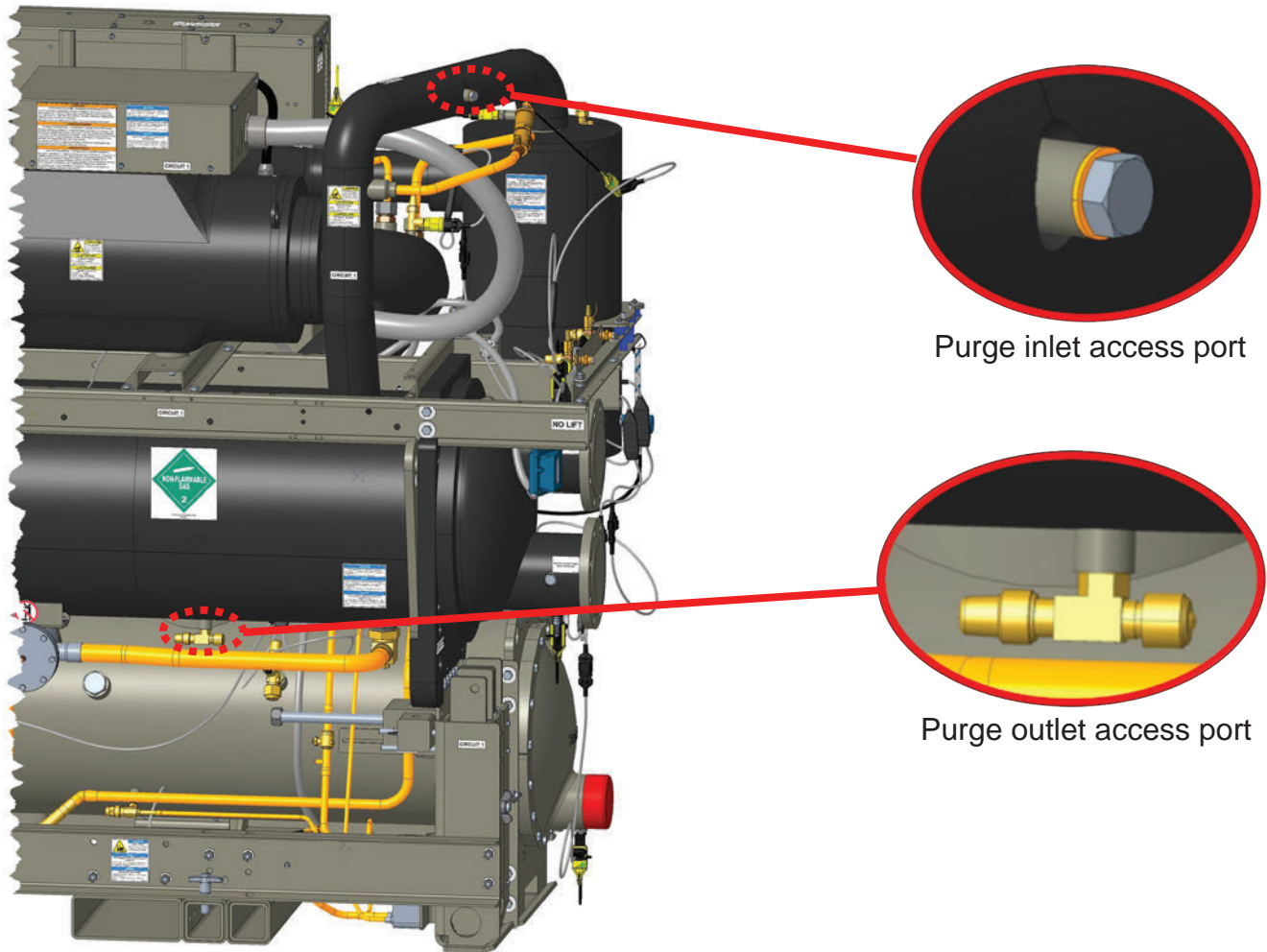

## Installation Requirements and Contractor Responsibilities

A list of the contractor responsibilities typically associated with the unit installation process is provided in the table below.

**Note:** Unit Start-up must be completed by a qualified Trane service technician.

**Table 2. Installation requirements**

Type of Requirement	Trane-Supplied		Field-Supplied Field-Installed
	Trane-Installed	Field-Installed	
Foundation			Meet foundation requirements
Rigging	Anti-tip device		Safety chains clevis connectors
	Lifting eyes		Lifting beam
	Tie-downs		
Isolation		Isolation pads or neoprene isolators (optional)	Isolation pads or neoprene isolators (optional)



## Pre-Installation

**Table 2. Installation requirements (continued)**

Type of Requirement	Trane-Supplied		Field-Supplied Field-Installed
	Trane-Installed	Field-Installed	
Electrical	Circuit breakers	Customer low voltage interface	Electrical connections to unit mounted starter (optional)
	Unit-mounted starter		Power supply wiring
	460V energy meter (optional)		Wiring sizes per submittal and NEC
			Terminal lugs
			Ground connection(s)
			BAS wiring (optional)
			External low voltage control wiring
Water piping	Differential pressure transducers (flow proving)	Water regulating valve (provided) and electrical power source control panel connection (120V power connect)	Water regulating valve (220v optional external power connect)
			Taps for thermometers and gauges
			Thermometers
			Pipe strainers (as required)
			Water flow pressure gauges
			Isolation and balancing valves in water piping
			Vents and drain on waterbox valves
			Pressure relief valves (for waterboxes as required)
			Vibration eliminators
Relief	Single relief valve		Vent line and flexible connector and vent line from relief valve to atmosphere
	Dual relief valve (optional)		
Insulation	Insulation		Insulation
Water piping connection components	Grooved pipe (evaporator)		
	Flanged connection (condenser)		
Other materials	Dry nitrogen (15 to 20 psig per circuit)		Refrigerant – 180.8 lb/82 kg per circuit

## Unit Connections and Components

### Unit Connection Locations

Figure 6. Component locations

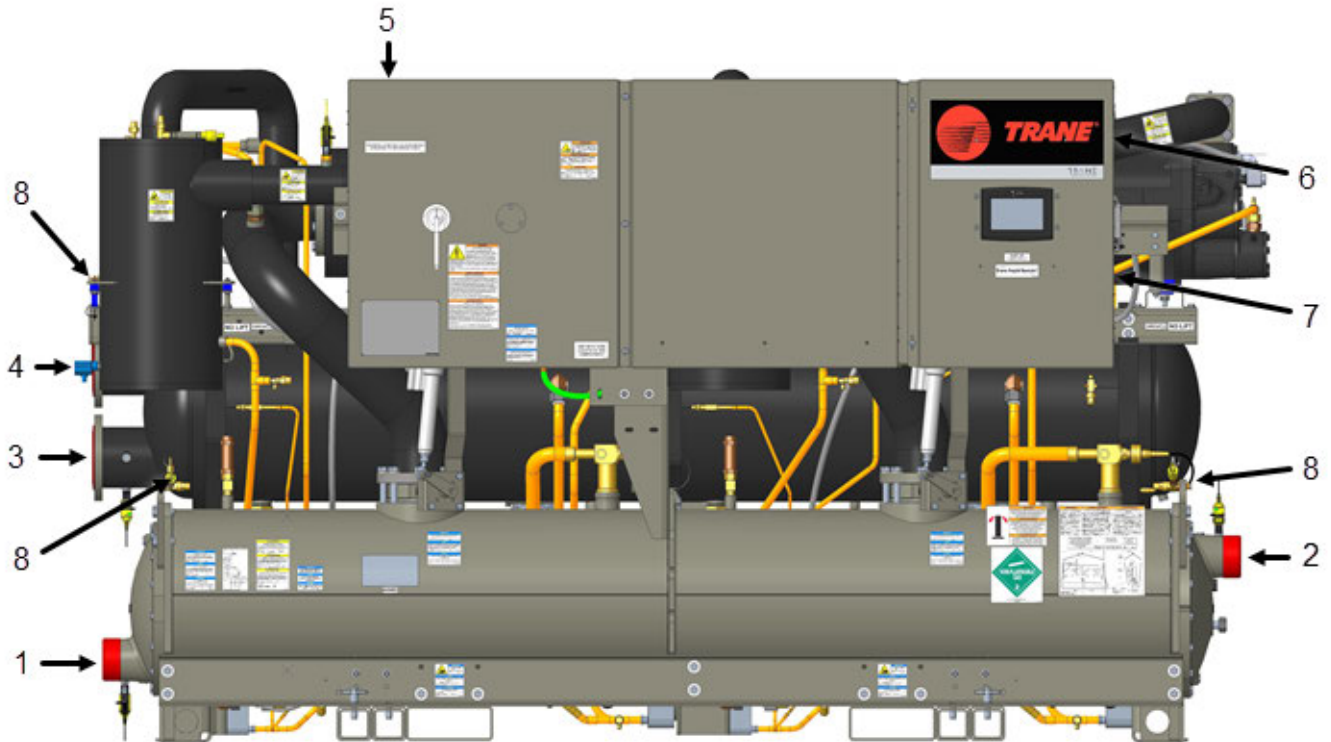

1. Evaporator water inlet
2. Evaporator water outlet (shown for 3 pass, 2 pass located on opposite side)
3. Condenser water inlet
4. Condenser water outlet
5. Power line voltage inlet
6. Customer control power high voltage inlet
7. Customer control power low voltage inlet
8. Differential pressure transducers

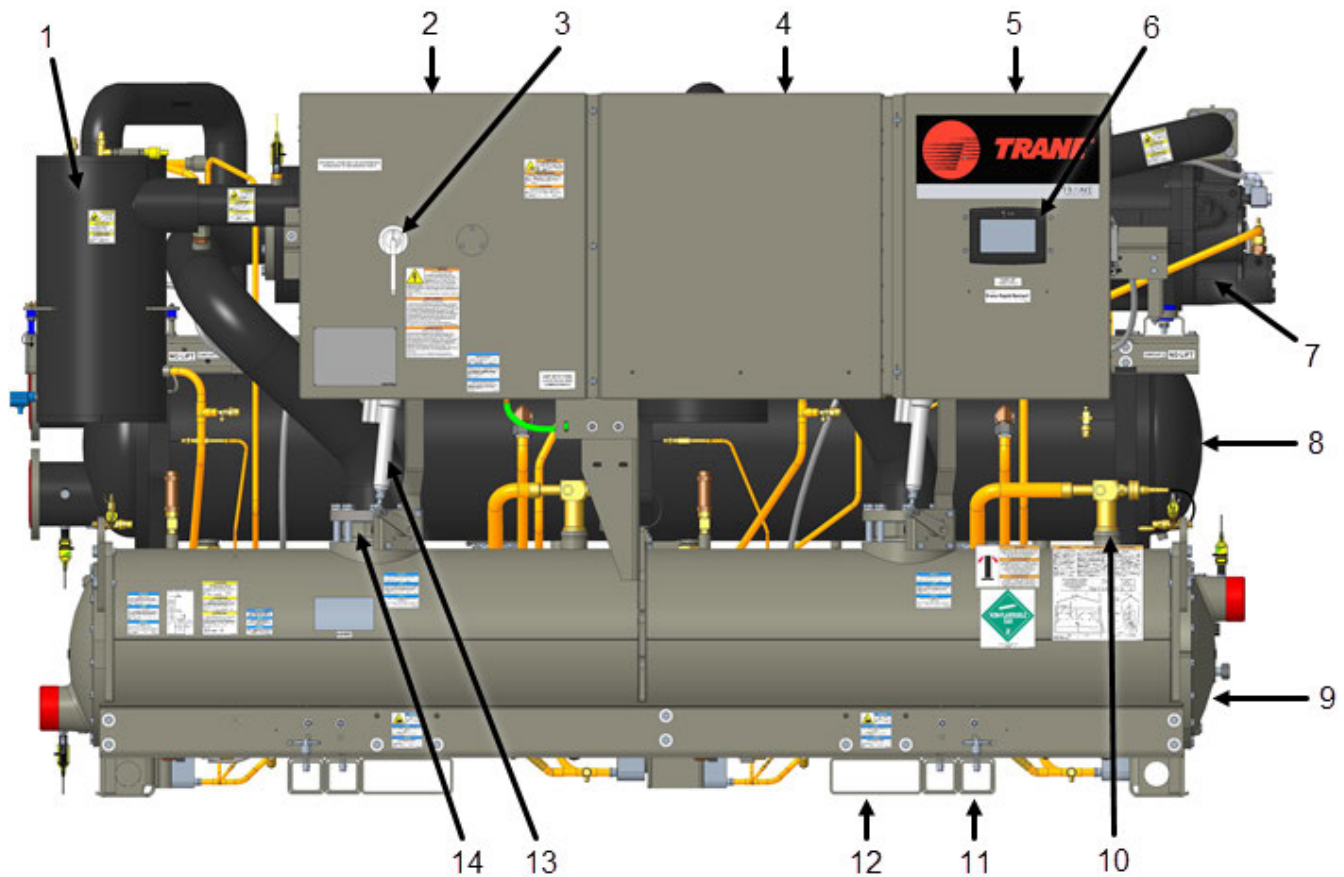
**Figure 7. Component locations – front**

1. Oil separator
2. High voltage/incoming power panel
3. Power disconnect
4. Starter panel
5. Low voltage power panel
6. Symbio 800 screen
7. Compressor
8. Condenser
9. Evaporator
10. EXV
11. Anti-tip device
12. Forklift pocket
13. Suction actuator
14. Suction butterfly valve

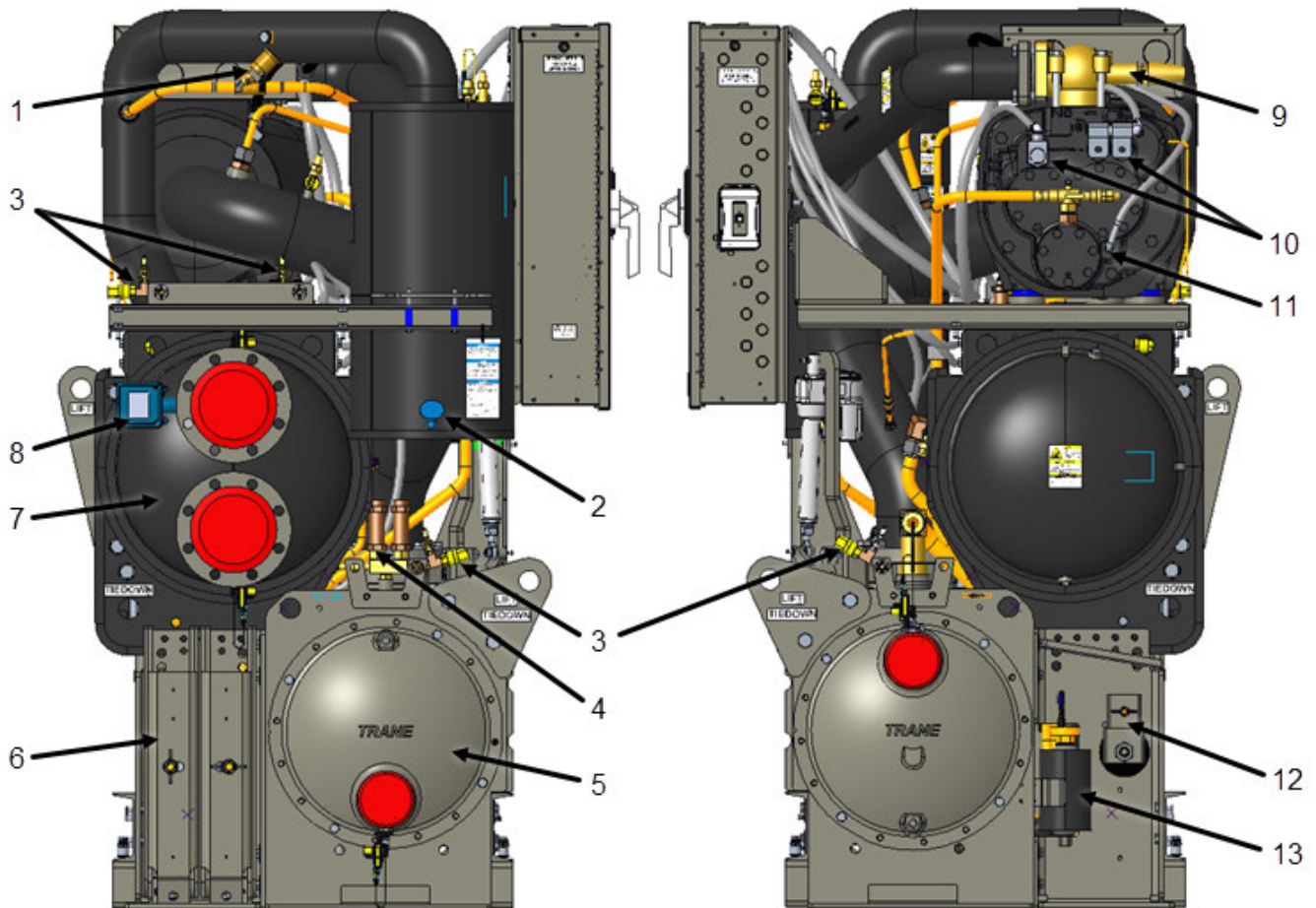
**Figure 8. Component locations – left and right**

1. Hot gas bypass valve
2. Separator oil eye sensor
3. Differential pressure transducer
4. Evaporator pressure relief
5. Evaporator waterbox
6. Anti-tip storage
7. Condenser waterbox
8. High temperature cutout switch
9. Compressor valve
10. Compressor solenoids
11. Compressor heater
12. Anti-tip foot storage
13. Evaporator liquid level sensor

Figure 9. Component locations – top

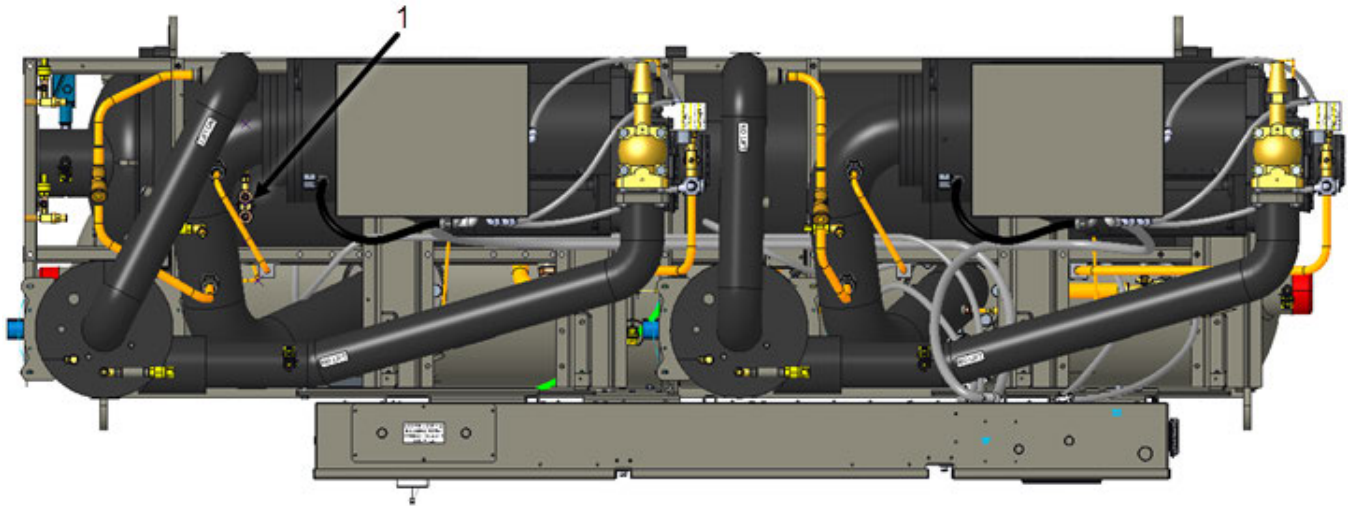

- 1. Condenser relief valve

Figure 10. Component locations – back

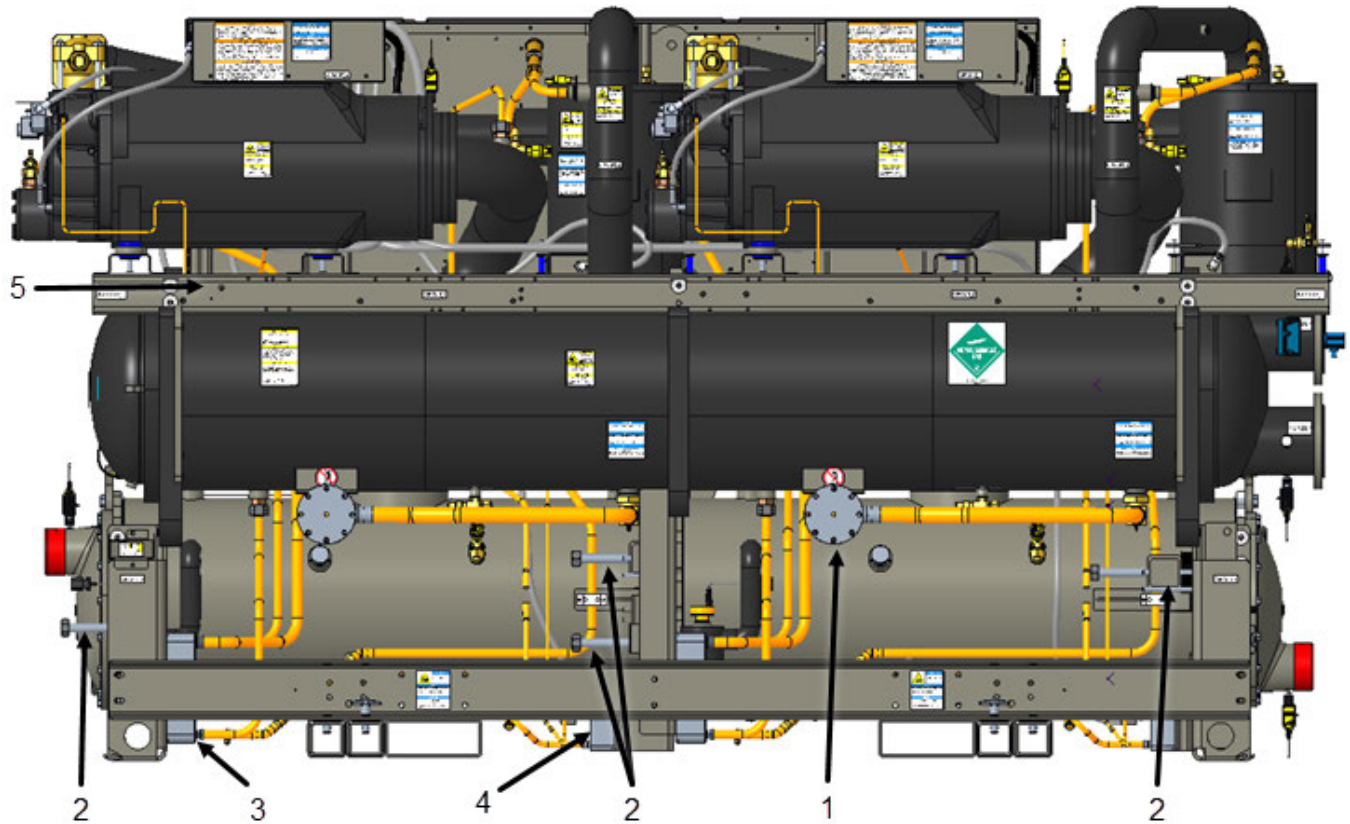

- 1. Filter dryer
- 2. Anti-tip feet storage
- 3. Oil cooler braze plate
- 4. Thermosyphon braze plate
- 5. Compressor pressure transducer (behind the compressor base rail)

# Unit Dimensions and Weights

## Unit Dimensions

Figure 11. Unit dimensions – 3 pass side

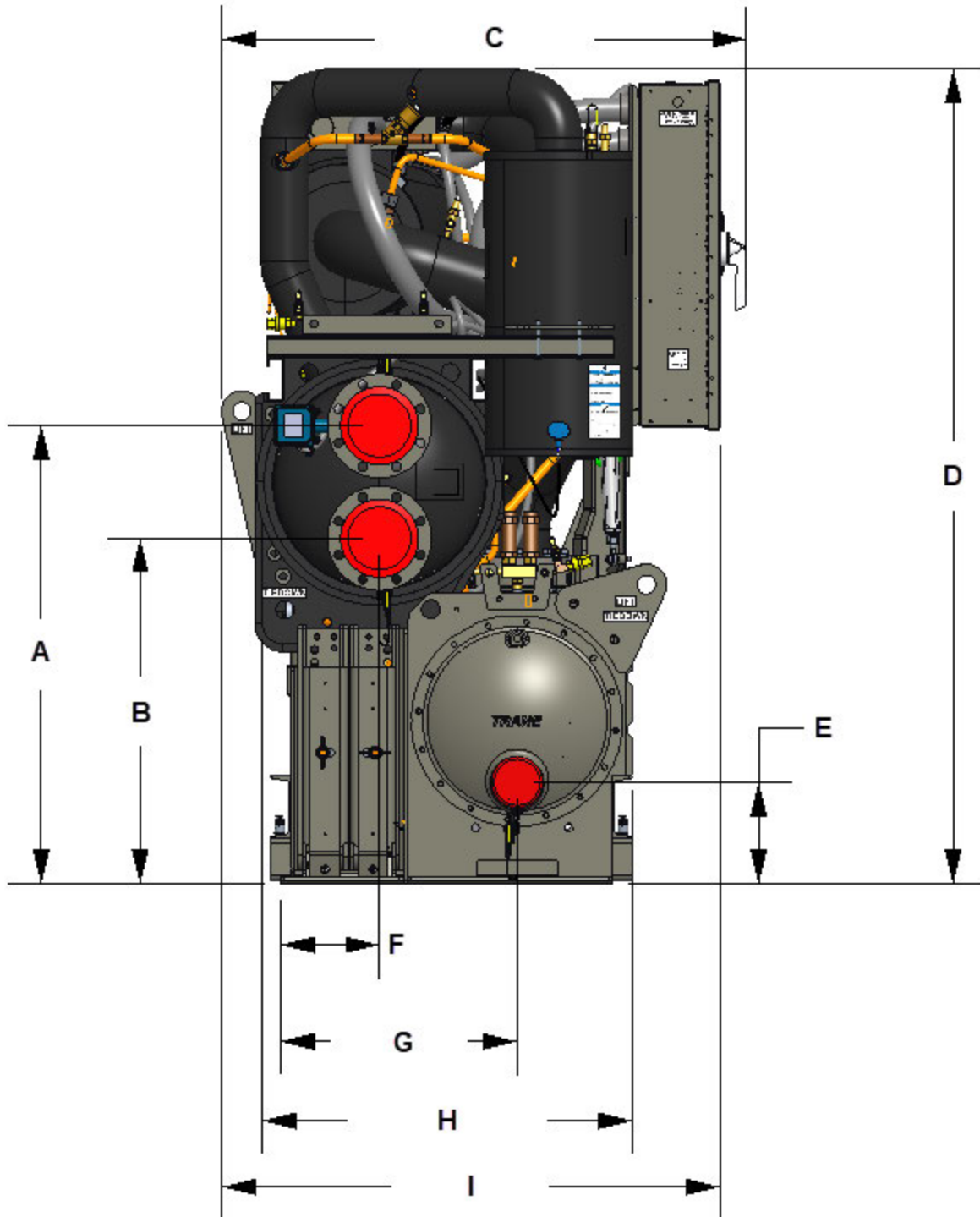



## Unit Dimensions and Weights

**Table 3. Unit dimensions – 3 pass side**

Reference	Dimension — inches/mm
A	43.9 inches (1115 mm)
B	33.1 inches (841 mm)
C	50.2 inches (1276.2 mm)
D	78.1 inches (1982.8 mm)
E	9.7 inches (246.8 mm)
F	9.5 inches (240.6 mm)
G	22.7 inches (575.6 mm)
H	35.43 inches (900 mm)*
I	47.7 inches (1211.8 mm)

\*Remove the 3/4-inch insulation from the condenser tube sheets. Dimensions with insulation installed is 36.18 inches (919 mm).

**Figure 12. Unit dimensions – 3 pass front**

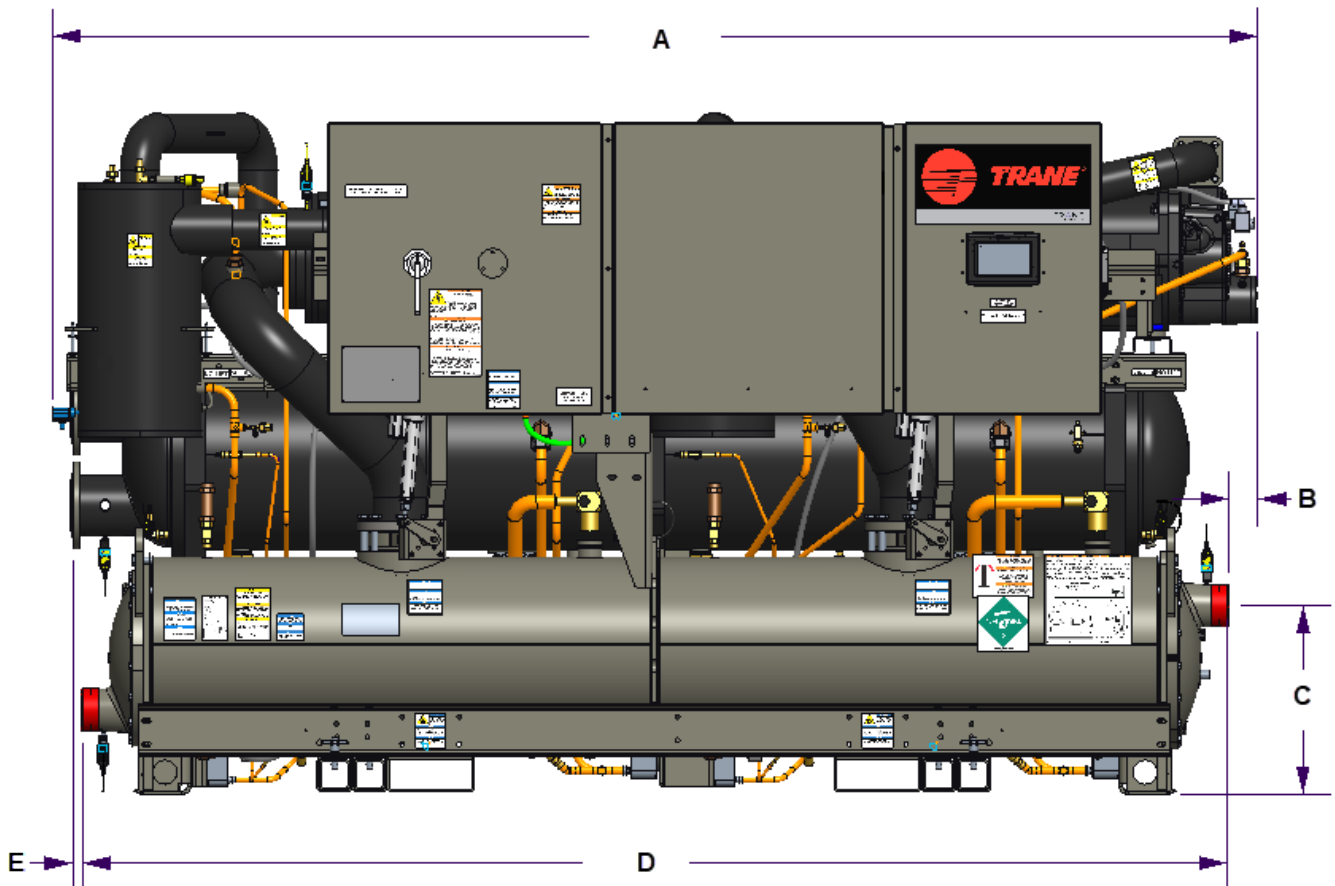

**Table 4. Unit dimensions – 3 pass front**

Reference	Dimension — inches/mm
A	138.1 inches (3507.2 mm)
B	3.3 inches (84.3 mm)

**Table 4. Unit dimensions – 3 pass front (continued)**

Reference	Dimension — inches/mm
C	21.6 inches (549.8 mm)
D	131.1 inches (3331.0 mm)
E	1.1 inches (28.3 mm)

**Figure 13. Unit dimensions – 2 pass front**

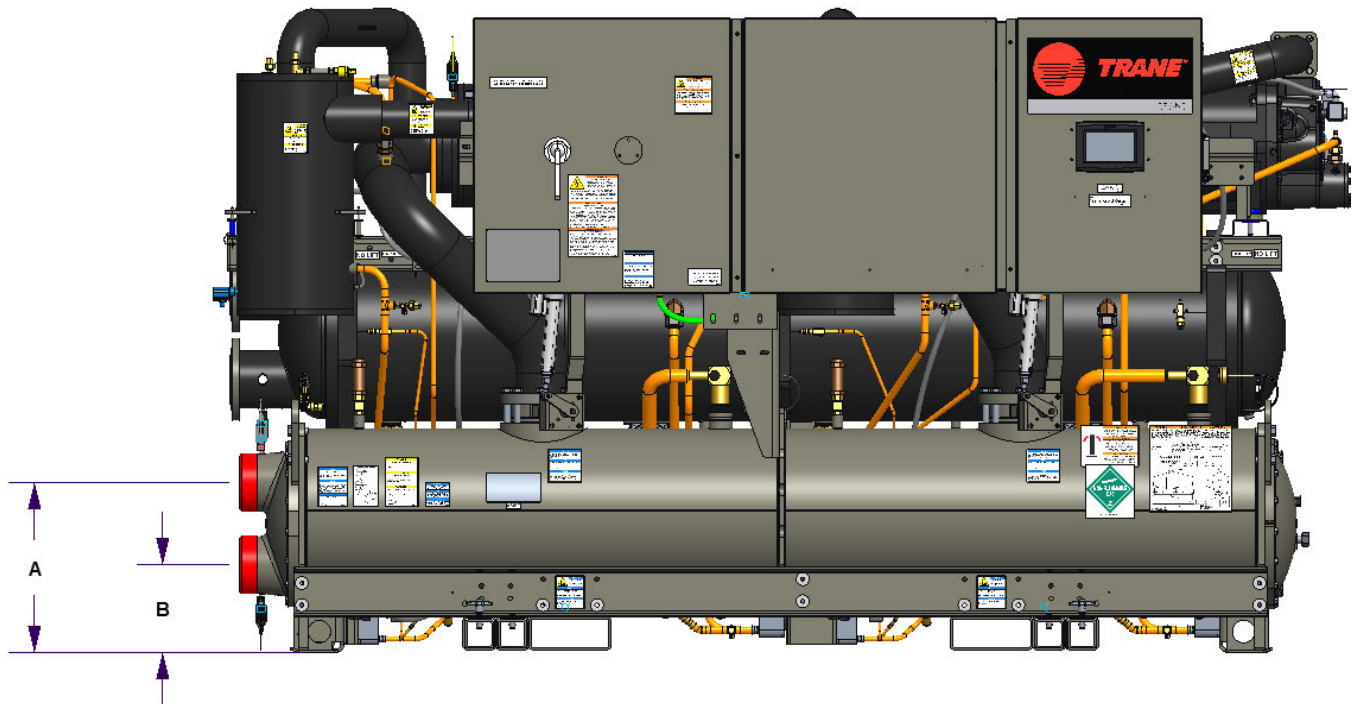

**Table 5. Unit dimensions – 2 pass front**

Reference	Dimension — inches/mm
A	20.6 inches (523.8 mm)
B	10.6 inches (269.8 mm)

# Unit Center of Gravity

Figure 14. Unit center of gravity – rear

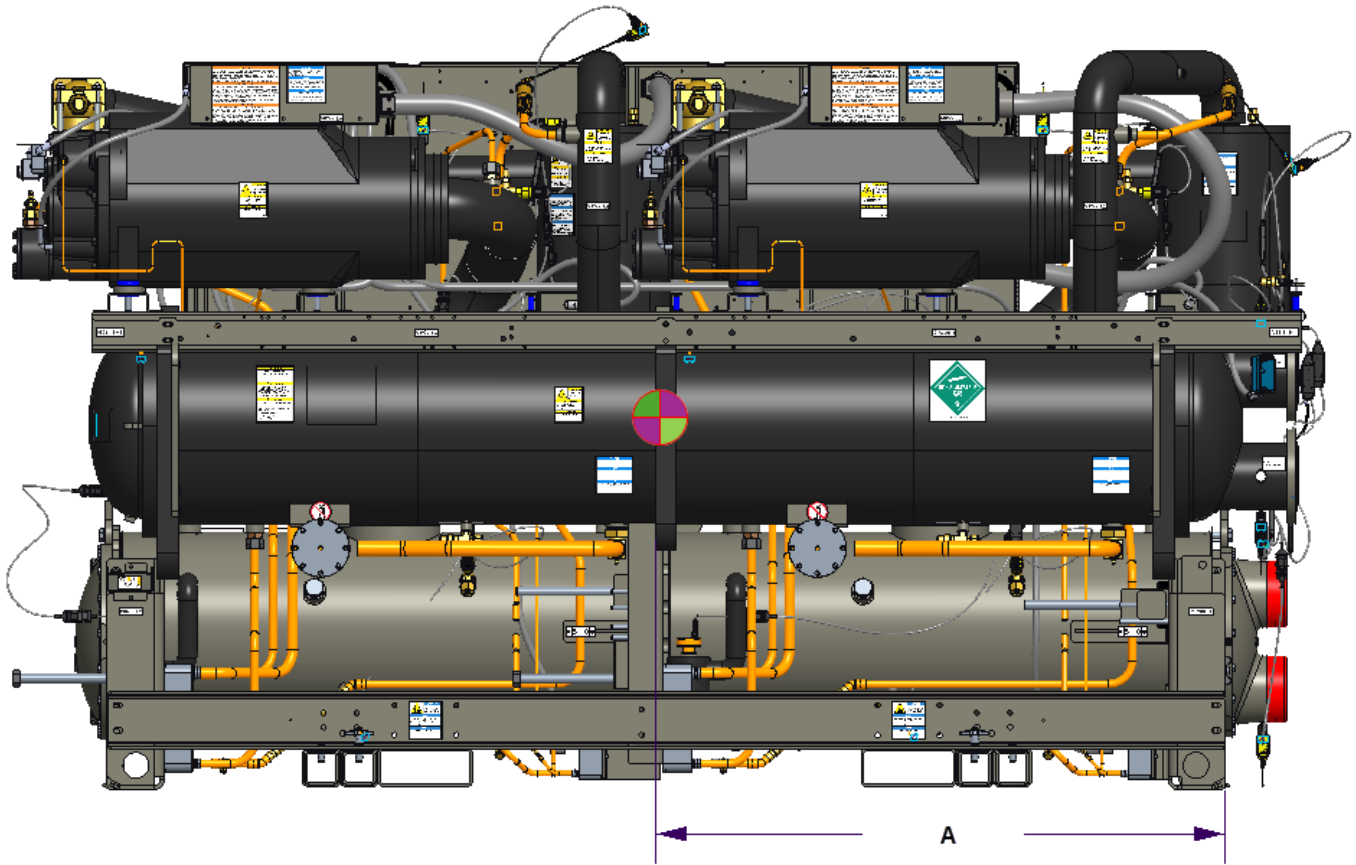

Table 6. Unit center of gravity – rear

Reference	Dimension — inches/mm
A	59.2 inches (1503 mm)

Figure 15. Unit center of gravity – side

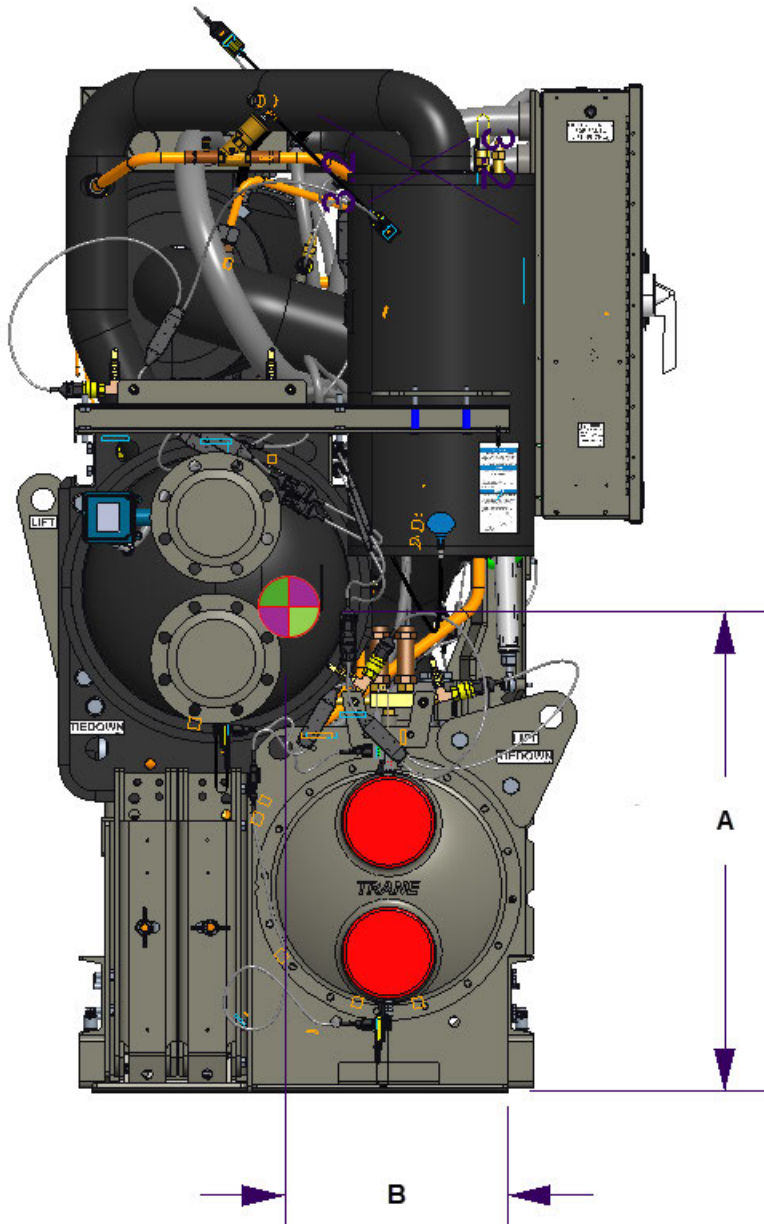

Table 7. Unit center of gravity – side

Reference	Dimension — inches/mm
A	39.6 inches (1006 mm)
B	16.2 inches (411 mm)



## Unit Dimensions and Weights

### Unit Clearances

Figure 16. Unit required clearances – 3 pass side

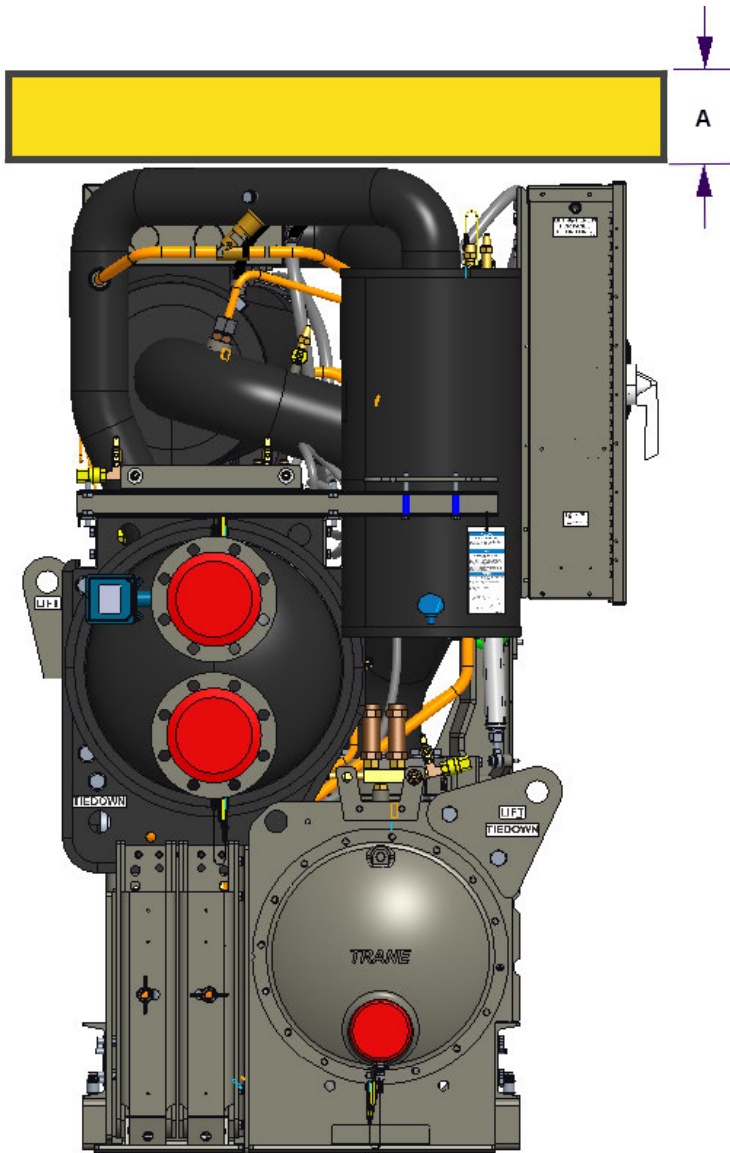

Figure 17. Unit required clearances – side

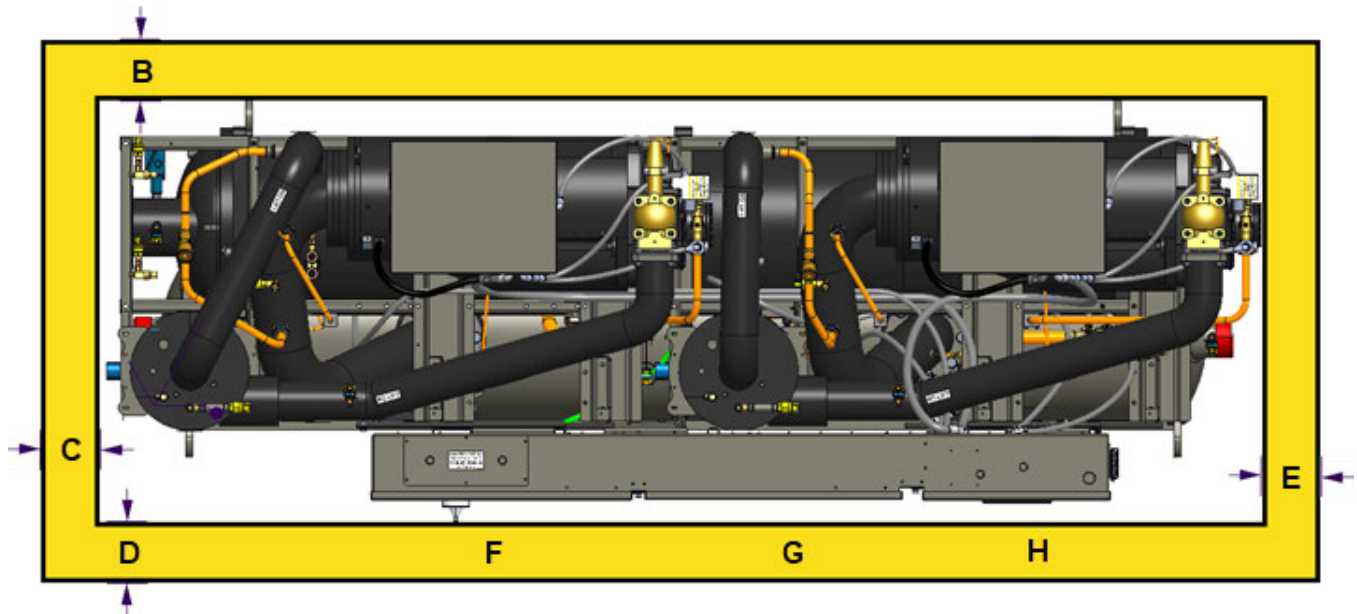
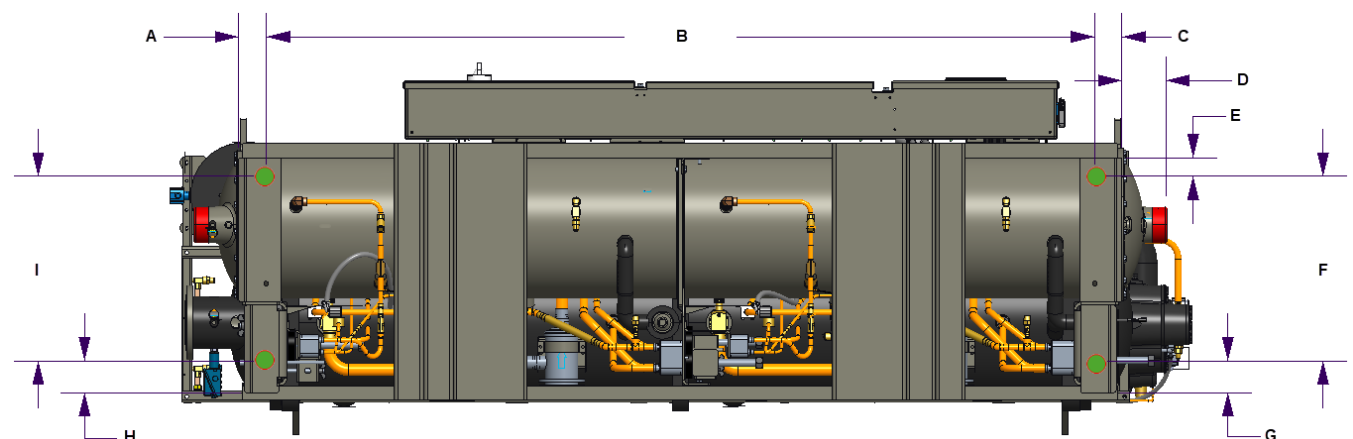

Table 8. Unit clearances

Reference	Dimension — inches/mm
A	36 inches (914 mm)
B	36 inches (914 mm)
C	36 inches (914 mm)
D	40 inches (1016 mm)
E	114.8 inches (2916 mm)
F (Door Swing)	31.3 inches (769.9 mm)
G (Door Swing)	31.1 inches (790.1 mm)
H (Door Swing)	22.4 inches (568.1 mm)

## Unit Footprint Dimensions

Figure 18. RTZA footprint bolt locations





## Unit Dimensions and Weights

**Table 9. Footprint bolt locations**

Reference	Dimension — inches/mm
A	3.7 inches (93.5 mm)
B	112 inches (2843.9 mm)
C	3.7 inches (93.5 mm)
D	5.9 inches (150 mm)
E	2.5 inches (64 mm)
F	24.9 inches (633.3 mm)
G	4.3 inches (109.3 mm)
H	4.3 inches (109.3 mm)
I	24.9 inches (633.3 mm)

## Weights

**Operating:** 10,022 lb (4,546 kg)

**Shipping:** 9,431 lb (4,278 kg)

## Corner Weights

**Figure 19. Corner weights – bottom view**

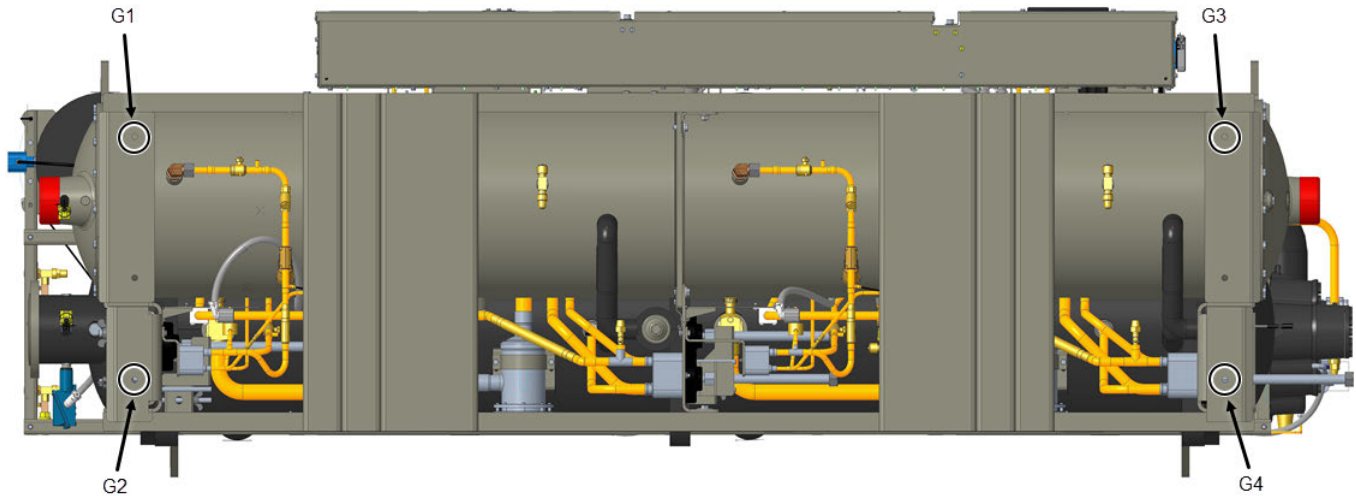

**Table 10. Corner weights**

G1 – lb (kg)	G2 – lb (kg)	G3 – lb (kg)	G4 – lb (kg)	X1 – inches (mm)	Z1 – inches (mm)	G1, G2, G3, G4 – inches (mm)
2,343 (1,063)	2,864 (1,299)	2,361 (1,071)	2,887 (1,310)	59.13 (1,502)	13.66 (347)	0.63 (16)

**Important:** The isolators need to be installed under G1, G2, G3, and G4.



# Installation – Mechanical

## Location Requirements

### Noise Considerations

The RTZA model has an elevated noise level and is regularly above 85 dB, requiring the use of ear protection when in the area of the appliance.

- Locate the unit away from sound-sensitive areas.
- Install the isolation pads under the unit. See “Unit Isolation and Leveling,” p. 43.
- Install rubber vibration isolators in all water piping.
- Seal all wall penetrations.

**Note:** Consult an acoustic engineer for critical applications.

### Foundation

Provide rigid, non-warping mounting pads or a concrete foundation of sufficient strength and mass to support the applicable operating weight (including completed piping, and full operating charges of refrigerant, oil, and water). See “Unit Dimensions and Weights,” p. 27 for unit operating weights. Once in place, the unit must be level within 1/4 inch (6.4 mm) over its length and width. The Trane Company is not responsible for equipment problems resulting from an improperly designed or constructed foundation.

### Clearances

Provide enough space around the unit to allow the installation and maintenance personnel unrestricted access to all service points. Refer to submittal drawings for the unit dimensions, to provide sufficient clearance for the opening of control panel doors and unit service. See “Unit Dimensions and Weights,” p. 27 for minimum clearances. In all cases, local codes which require additional clearances will take precedence over these recommendations.

**Note:** The required vertical clearance above the unit is 36 inches (914.4 mm). There should be no piping or conduit located over the compressor motor. If the unit configuration requires a variance to the clearance dimensions, contact your Trane Sales Office Representative.

### Ventilation

The unit produces heat and provisions should be made to remove heat generated by unit operation from the equipment room. Ventilation must be adequate to maintain an ambient temperature lower than 104°F (40°C).

The minimum ambient room temperature should be maintained at or above 65°F (see “Post-Installation with Refrigerant,” p. 20).

### Heat Considerations

#### ⚠ CAUTION

##### Hot Surface!

Failure to follow instructions below could result in moderate injury.

Surface temperatures can reach 150°F (66°C). To avoid possible skin burns, stay clear of these surfaces. If possible, allow surfaces to cool before servicing. If servicing is necessary while surface temperatures are still elevated, you **MUST** put on all Personal Protective Equipment (PPE).

Foam insulation is installed on key heat pump components. The standard, 3/4-inch thick insulation is installed on the compressor suction pipe, compressor, compressor discharge piping, oil separator, oil separator discharge piping, condenser, and evaporator liquid level sensor canister and canister copper piping.

**Note:** Insulation is not applied to all hot surfaces for user protection, and warning labels identify hot areas. Insulation is used primarily to reduce heat transfer and improve unit performance. During operation and shutdown, avoid touching surfaces. If work on the unit is required, use a non-contact thermometer to check surface temperatures. If direct contact is necessary, wear appropriate PPE.



## Moving and Rigging

### **⚠ WARNING**

#### **Heavy Objects!**

Failure to follow instructions below or properly lift unit could result in unit dropping and possibly crushing operator/ technician which could result in death or serious injury, and equipment or property-only damage.

- Equipment is top heavy. Use caution when lifting/ moving equipment to prevent unit from tipping.
- Ensure that all the lifting equipment used is properly rated for the weight of the unit being lifted. Each of the cables (chains or slings), hooks, and shackles used to lift the unit must be capable of supporting the entire weight of the unit. Lifting cables (chains or slings) may not be of the same length. Adjust as necessary for even unit lift.
- The high center of gravity on this unit requires the use of an anti-rolling cable (chain or sling). To prevent unit from rolling, attach cable (chain or sling) with no tension and minimal slack around compressor suction pipe as shown.
- Do not use forklift to move or lift unit unless unit has lifting base with base rail forklifting option.

### **⚠ WARNING**

#### **Improper Unit Lift!**

Failure to properly lift unit in a LEVEL position could result in unit dropping and possibly crushing operator/ technician which could result in death or serious injury, and equipment or property-only damage.

Test lift unit approximately 24 inches (61 cm) to verify proper center of gravity lift point. To avoid dropping of unit, reposition lifting point if unit is not level.

## Truck Transportation Tie-Downs

Four tie-down locations are provided for transportation. See the below figures and unit labels for tie-down locations. For units with full shrink wrap, slits are provided in the bag for access to tie-down locations.

See [Figure 20, p. 37](#) and [Figure 21, p. 37](#) for the recommended tie-down method. Use properly sized and load-rated chains. See “Unit Dimensions and Weights,” [p. 27](#) for unit weights. Do not fully remove or fully tighten chains unless all four points are connected.

When installing or removing chains, verify that there is an equal and balanced preload so that the unit does not tip over.

**Figure 20. Truck trailer deck – front and rear view**

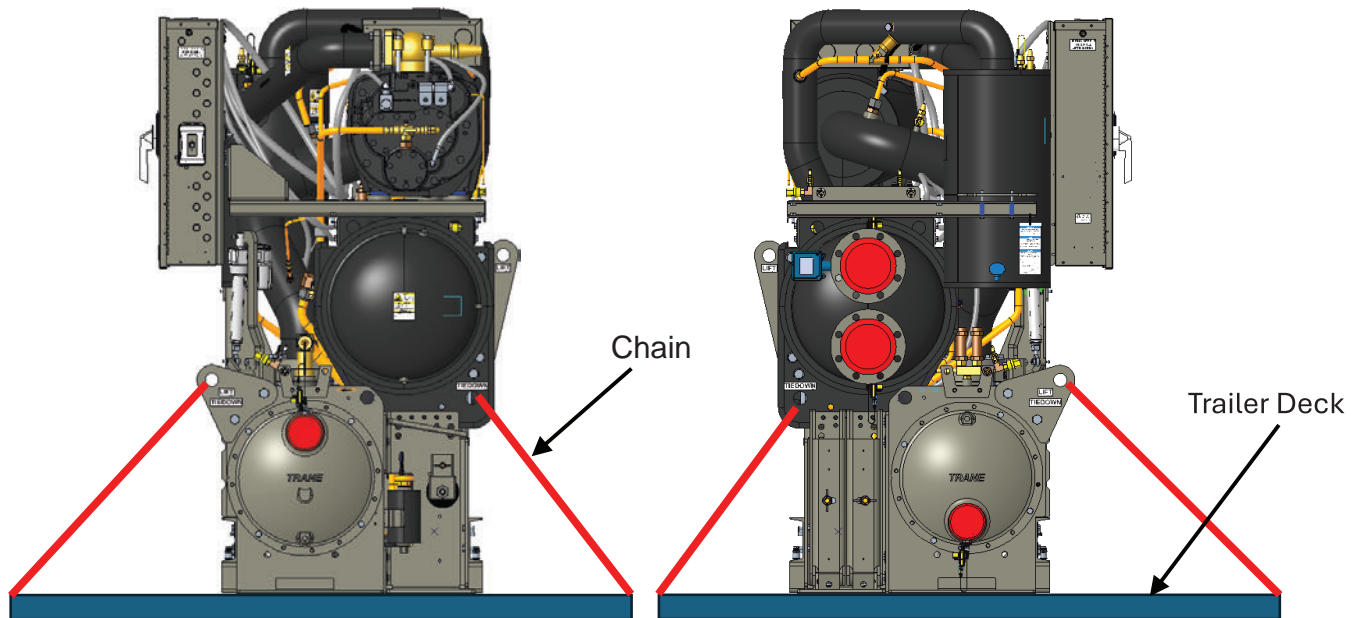

**Figure 21. Truck trailer deck – side view**

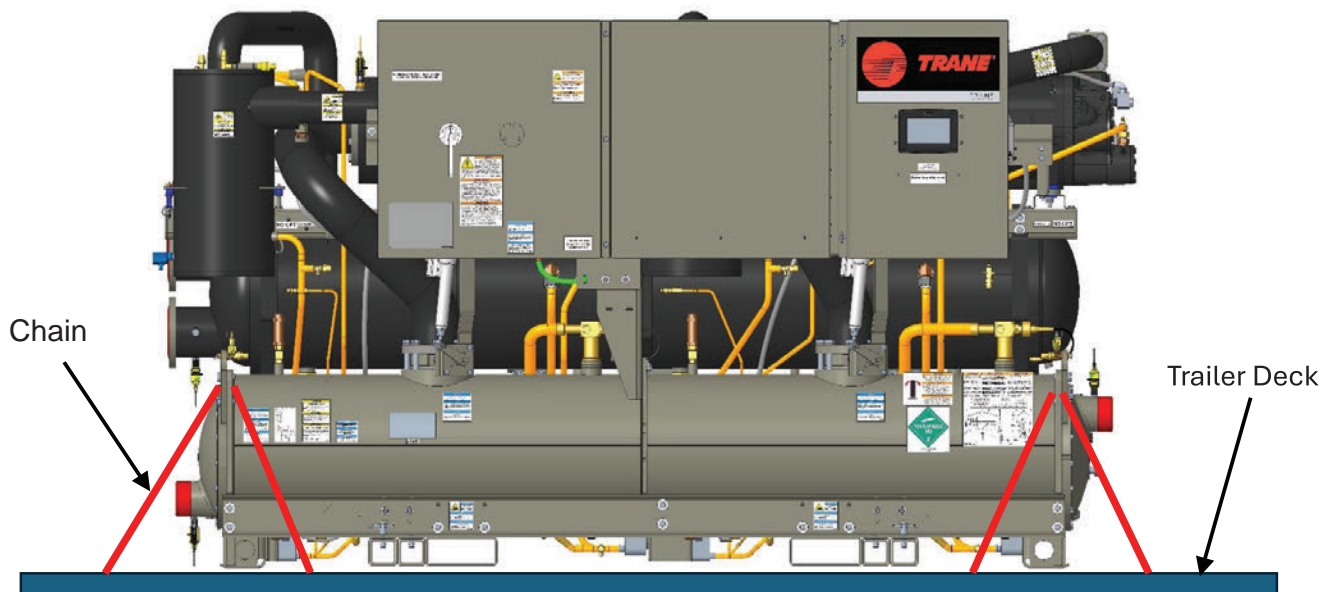

## Forklift Move

A full-width forklift pocket is provided (see [Figure 7, p. 24](#)). The pocket dimensions are 3.5 in. × 9.5 in., with 51.2 in. center-to-center spacing. Use only the designated forklift pocket locations for moving the unit.

## Overhead Lift

The unit includes four designated lift points. Attach chains or cables to a lifting beam as shown in [Figure 22, p. 38](#). Position the lifting beam crossbars so the cables do not contact the unit sides. Attach the anti-rolling cable to the Circuit 2 compressor suction pipe. Adjust lifting chains or cables as needed for a level lift.

**Figure 22. Rigging for overhead lifting**

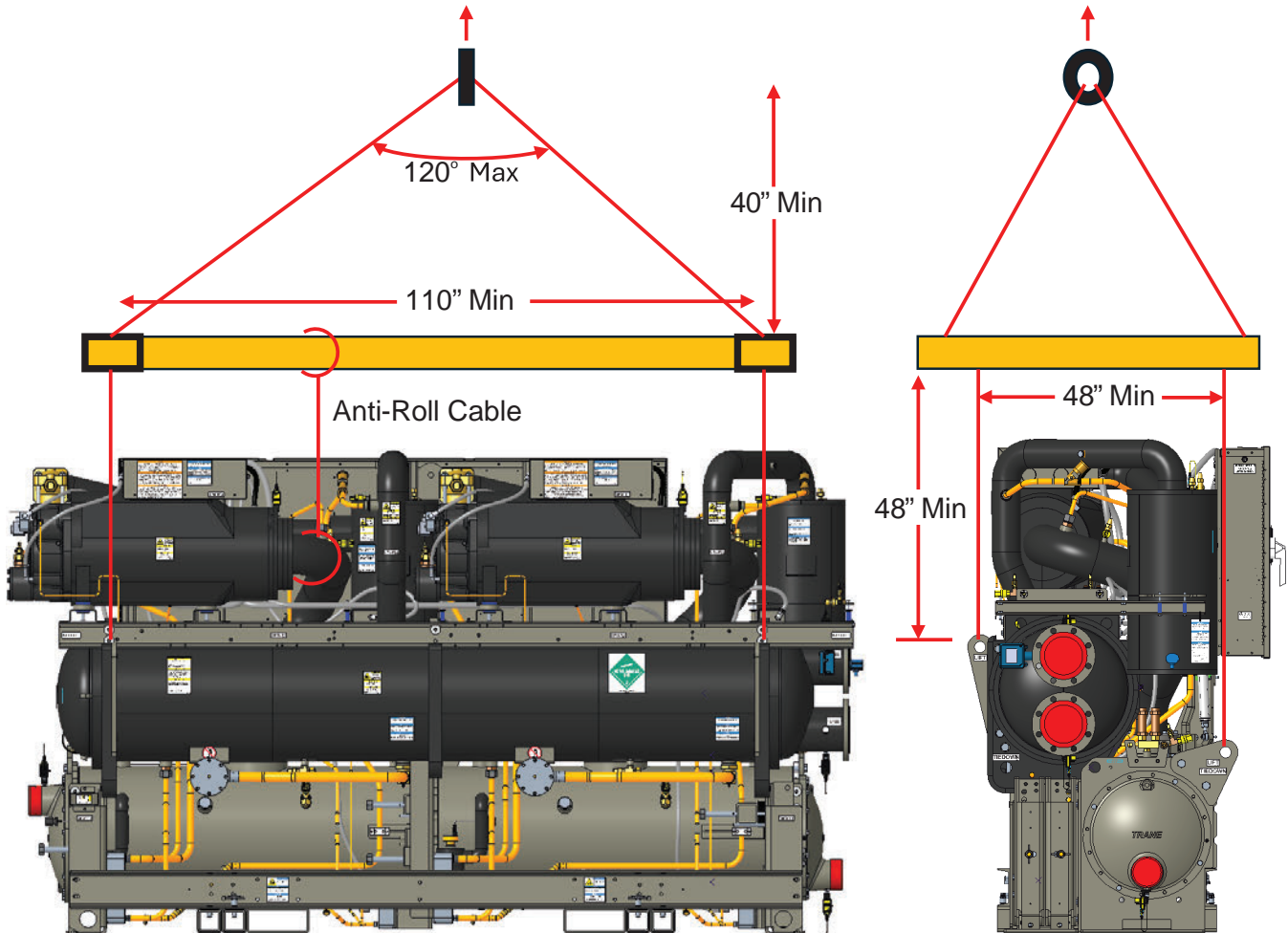

## Dolly Move

When moving the unit with a dolly, the anti-tip outriggers must be used to prevent tipping caused by the high center of gravity. The outriggers are located in the base rail support structure, and the outrigger feet and control arms are stored in the tube sheet support structures. These locations are shown below.

**Figure 23. Anti-tip foot and outrigger**

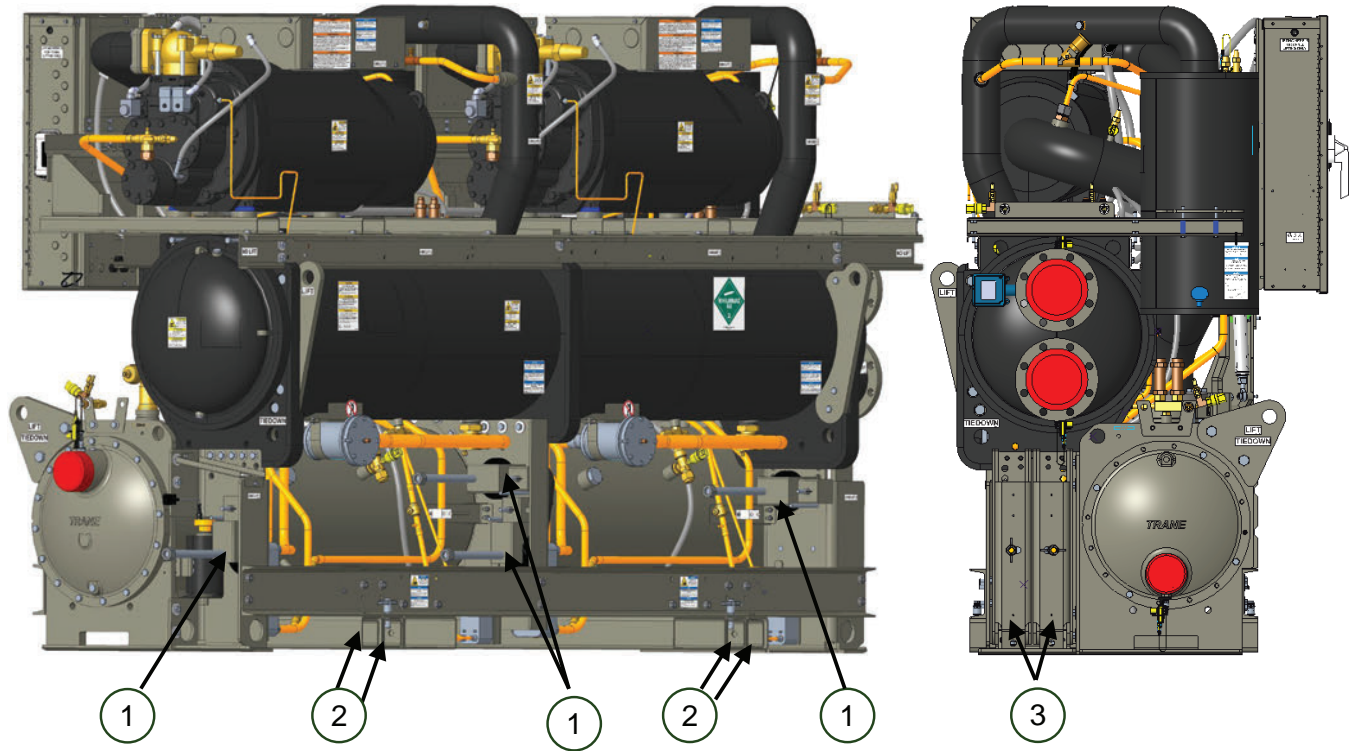

1. Anti-tip foot
2. Outrigger
3. Outrigger control arm (with tee pins)

Before lifting or moving the unit, deploy the anti-tip device (see [Figure 24, p. 40](#)). Remove the anti-tip feet and control arms from their storage locations, then follow the steps below for each of the four outrigger locations.

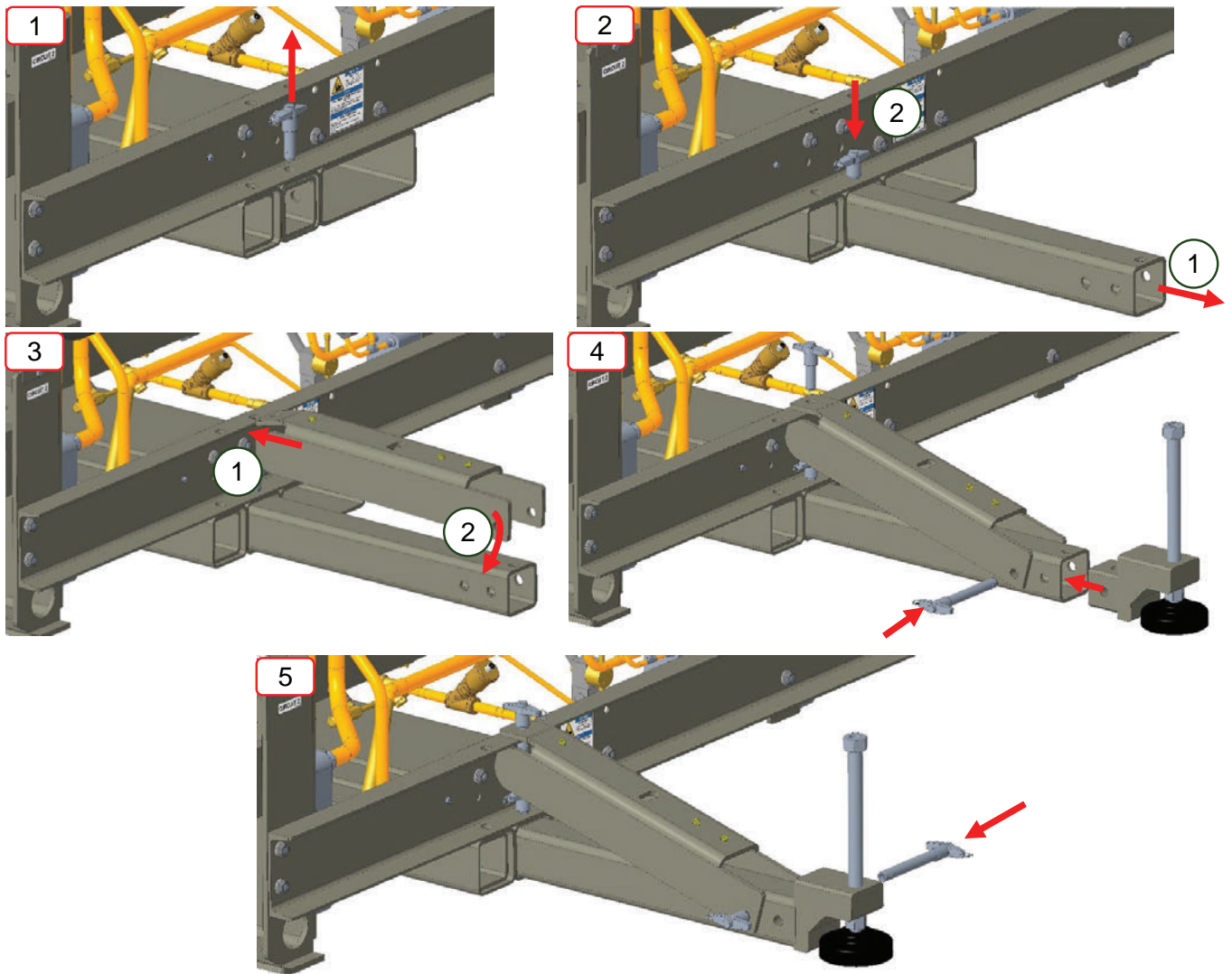
**Figure 24. Anti-tip device deployment**

Once all the outriggers are deployed the unit may be lifted onto the dolly. The dolly should only be placed on the surfaces shown below. The dolly should secure tightly to the unit bottom surface with either an external clamp mechanism or utilizing the three available 5/8-inch diameter holes on each surface.

**Figure 25. Surfaces for dolly**

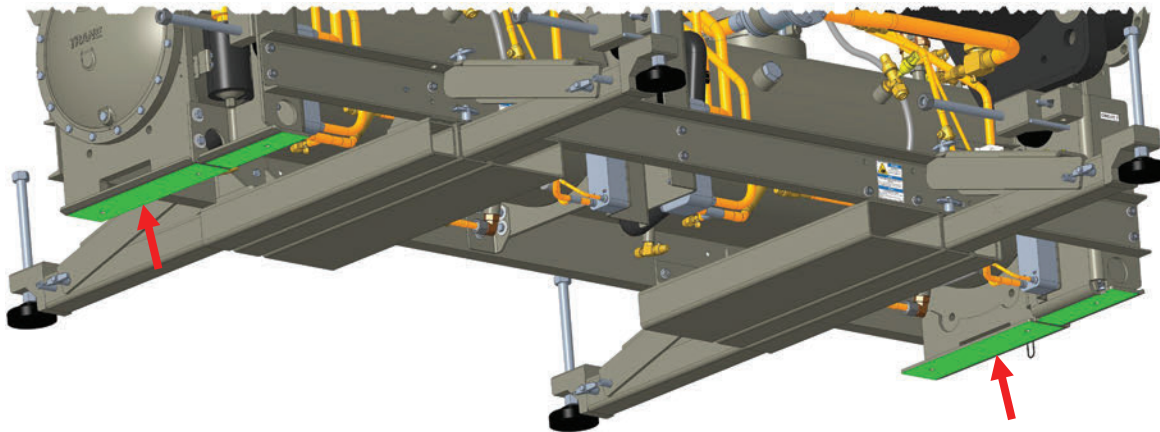

When the unit is on a flat surface, the anti-tip feet sit approximately 0.5 in. above the ground. The maximum allowable dolly height is 9.8 in. from the ground to the top of the dolly surface. At this height, the anti-tip feet can be fully extended while maintaining about 1 inch of ground clearance. Maintain the 1-inch clearance for any dolly height (see [Figure 26, p. 41](#)).

**Figure 26. Anti-tip feet clearance**

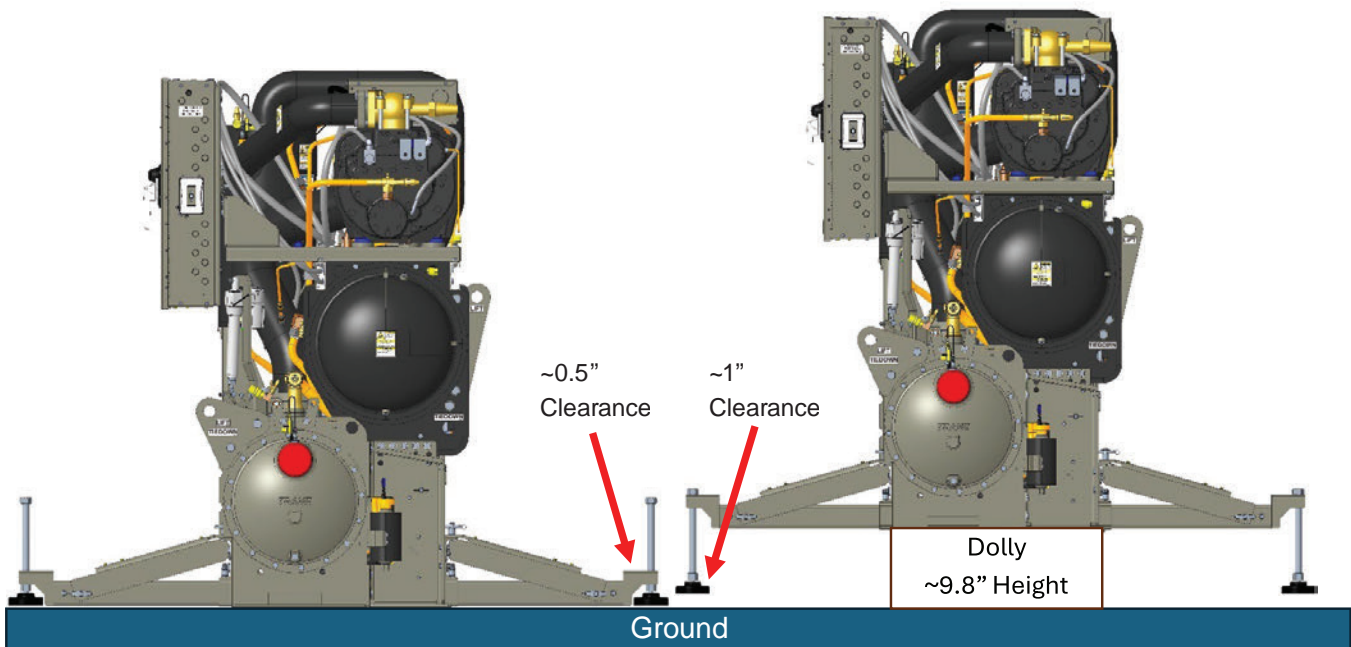

## Doorway

When transporting the unit through a doorway narrower than the outrigger width, move the unit through the threshold as shown in [Figure 27, p. 42](#).

1. Position the unit near the doorway. Collapse the forward outrigger closest to the doorway.
2. Move the unit partially through the doorway.
3. Deploy the collapsed outrigger.
4. Collapse the other outrigger.
5. Move the unit forward the rest of the way through the doorway.
6. Deploy the collapsed outrigger.
7. Move the unit to final location.

Once the unit reaches its final destination, disassemble and retract the anti-tip outriggers, then store the remaining items on the tube sheet supports.

**Figure 27. Move unit through doorway**

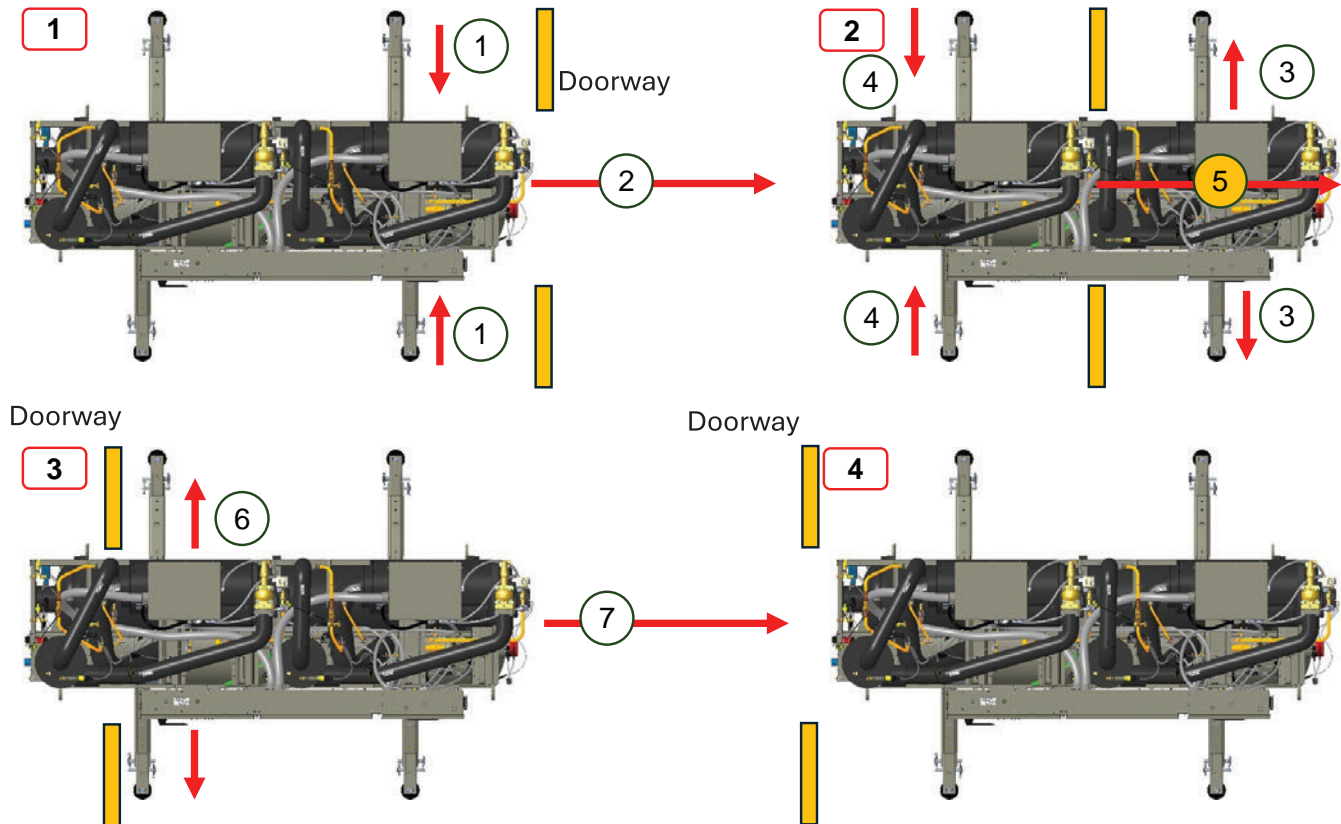

## Unit Isolation and Leveling

### ⚠ WARNING

#### Heavy Objects!

Failure to follow instructions below or properly lift unit could result in unit dropping and possibly crushing operator/ technician which could result in death or serious injury, and equipment or property-only damage.

- Equipment is top heavy. Use caution when lifting/ moving equipment to prevent unit from tipping.
- Ensure that all the lifting equipment used is properly rated for the weight of the unit being lifted. Each of the cables (chains or slings), hooks, and shackles used to lift the unit must be capable of supporting the entire weight of the unit. Lifting cables (chains or slings) may not be of the same length. Adjust as necessary for even unit lift.
- The high center of gravity on this unit requires the use of an anti-rolling cable (chain or sling). To prevent unit from rolling, attach cable (chain or sling) with no tension and minimal slack around compressor suction pipe as shown.
- Do not use forklift to move or lift unit unless unit has lifting base with base rail forklifting option.

### Isolation Pads

**Note:** The elastomeric pads shipped (as standard) are adequate for most installations. Consult an acoustical engineer for sound-sensitive installations.

1. Before installing, verify the requirements of “Foundation,” p. 35 are met.
2. Install or confirm location of foundation bolt studs (see “Unit Footprint Dimensions,” p. 33).
3. Place the isolation pads on the foundation on the unit mounting location.
4. Lower the unit on the isolators and secure with a nut.
5. Level the unit as required.
6. Fully tighten the isolator mounting bolts.

**Figure 28. Isolator pads**

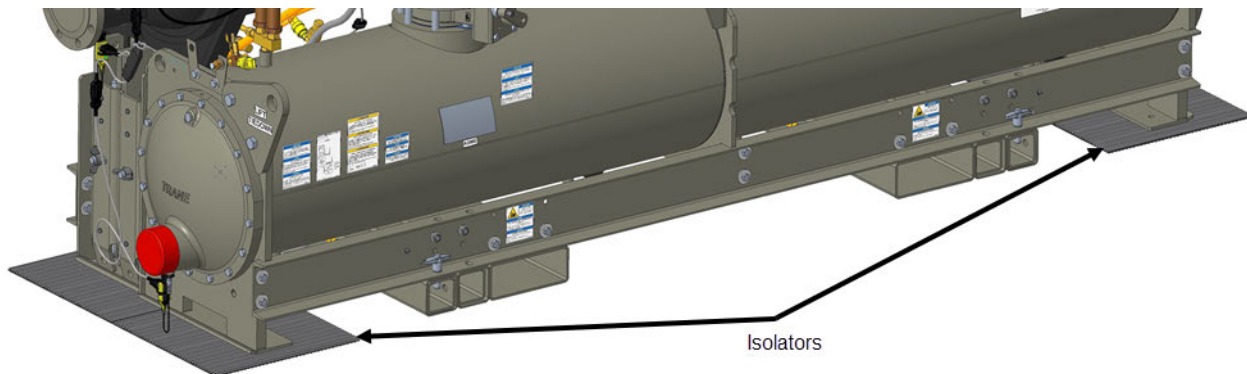

### Neoprene Isolator Installation (optional)

**Note:** Figure 29, p. 44 shows optional neoprene isolators.

1. Before installing, verify the foundation meets the requirements of “Foundation,” p. 35.  
Install neoprene isolators at each mounting location using the isolator base plate slots. See “,” p. 33 for mounting locations.
- Important:** Do not fully tighten isolator mounting bolts.
2. Align the mounting holes in the base of the unit with the threaded positioning pins on top of the isolators.
  3. Lower the unit on the isolators and install a nut to secure the isolator to the unit.
  4. Level the unit as required.
  5. Fully tighten the isolator mounting bolts.

Figure 29. Neoprene isolator

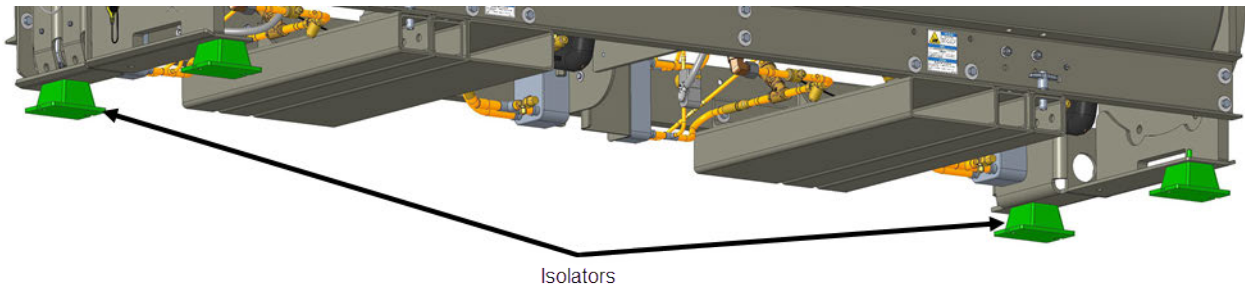

Figure 30. RTZA neoprene isolator

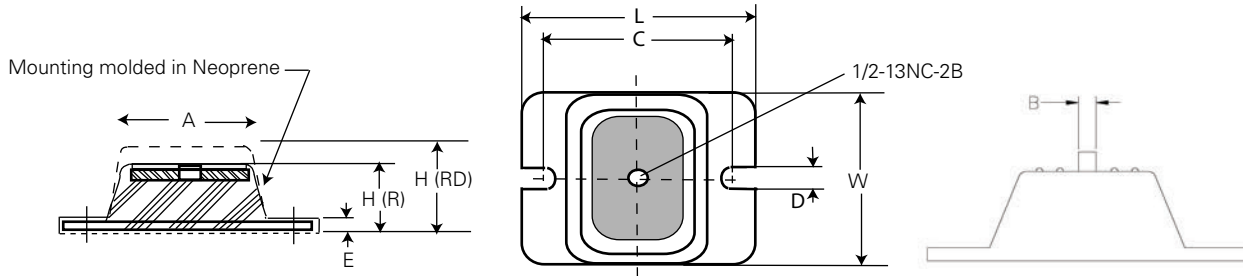

Table 11. Isolator dimensions

Isolator Type Color [Ext] Max Load – lb (kg)	Maximum Deflection (in)	Dimension – in (mm)							
		A	B	C	D	E	H	L	W
RDP-4 Green [63] 3000 (1361)	0.50	3.0 (76.2)	0.50 (12.7)	5.00 (127.0)	0.56 (14.2)	0.38 (9.7)	2.75 (69.8)	6.25 (158.8)	4.63 (117.6)

## Water Piping

### **NOTICE**

#### **Evaporator Damage!**

Failure to follow instructions below could cause damage to the evaporator.

The chilled water connections to the evaporator are to be grooved-pipe type connections. Do not attempt to weld these connections, as the heat generated from welding can cause microscopic and macroscopic fractures on the cast iron waterboxes that can lead to premature failure of the waterbox. To prevent damage to chilled water components, do not allow evaporator pressure (maximum working pressure) to exceed 150 psig (10.5 bar).

### **NOTICE**

#### **Equipment Damage!**

Failure to follow instructions below could result in damage to internal components of the evaporator.

If using an acidic commercial flushing solution when flushing the water piping, construct a temporary bypass around the unit.

### **NOTICE**

#### **Water Borne Debris!**

To prevent components damage, pipe strainers must be installed in the water supplies to protect components from water borne debris. Trane is not responsible for equipment-only-damage caused by water borne debris.

### **NOTICE**

#### **Proper Water Treatment Required!**

The use of untreated or improperly treated water could result in scaling, erosion, corrosion, algae or slime.

Use the services of a qualified water treatment specialist to determine what water treatment, if any, is required. Trane assumes no responsibility for equipment failures which result from untreated or improperly treated water, or saline or brackish water.

Piping components include all devices and controls used to provide proper water system operation and unit operating safety. These components and their general locations are provided below.

### **Unit System Level Piping**

Figure 31, p. 46 represents a typical customer system level piping connection layout.

1. Verify the location and unit isolation requirements (see “Unit Isolation and Leveling,” p. 43 and “Location Requirements,” p. 35).
2. Verify the unit isolators are installed between unit feet and the concrete foundation.
3. Thoroughly flush all water piping to the unit before making the final piping connections to this unit.
4. Locate the unit near a large capacity drain for water vessel drain-down during shutdown or repair. Condensers and evaporators are provided with drain connections. All local and national codes apply.
5. Verify rubber isolator connections are installed on each water line connected to the unit.
6. Verify each relief valve is connected to an exhaust piped to an outdoor space. Confirm the exhaust includes a rubber isolation connection.
7. Water pipes are supported and isolated. Water piping must not be connected in a way that introduces linear or torque forces on the unit connection points.
8. Piping through walls must not rest on the wall and is sealed to prevent air leakage.

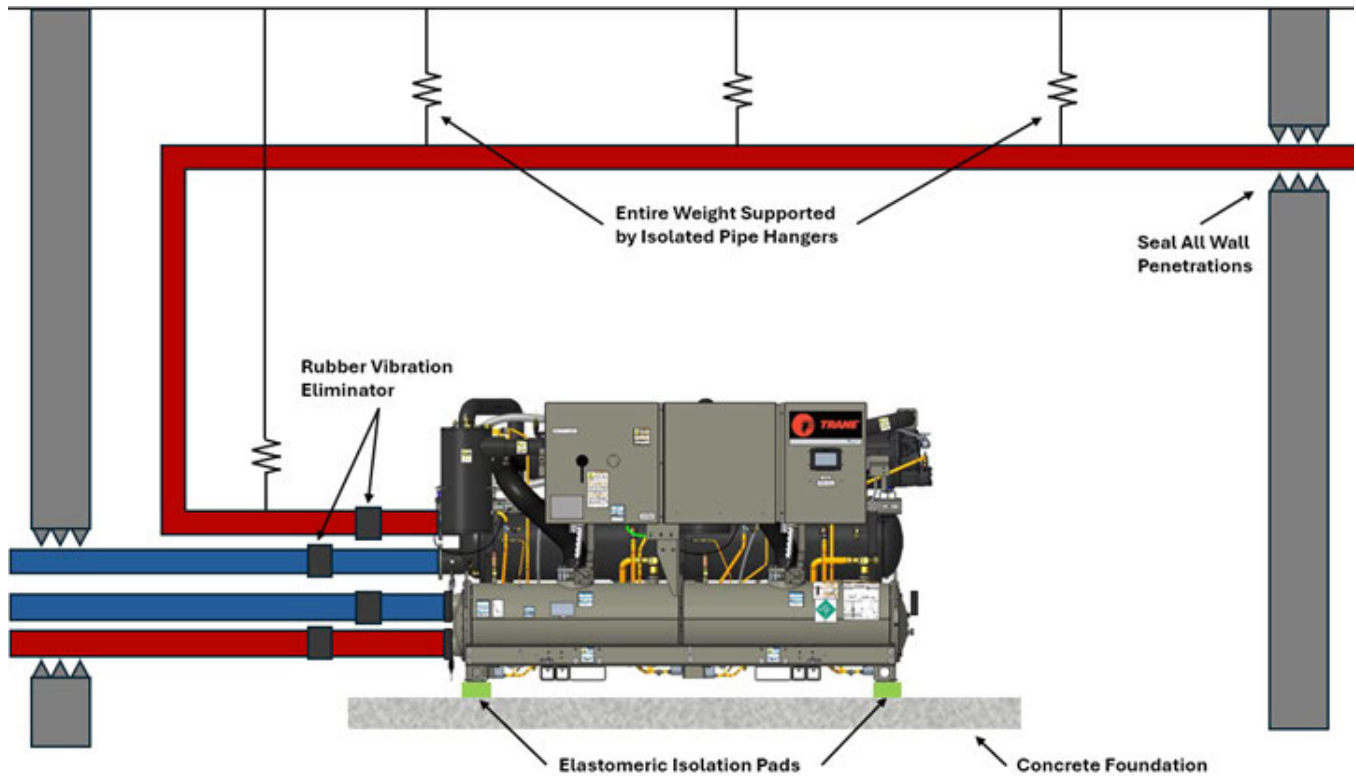
**Figure 31. Water piping layout**

### Field-Installed Components

See "Installation Requirements and Contractor Responsibilities," p. 21.

Figure 32, p. 47 shows typical customer water piping connection layout to the unit. This is a simplified representation of specific components. Actual customer installation may vary.

Figure 32. Water piping components

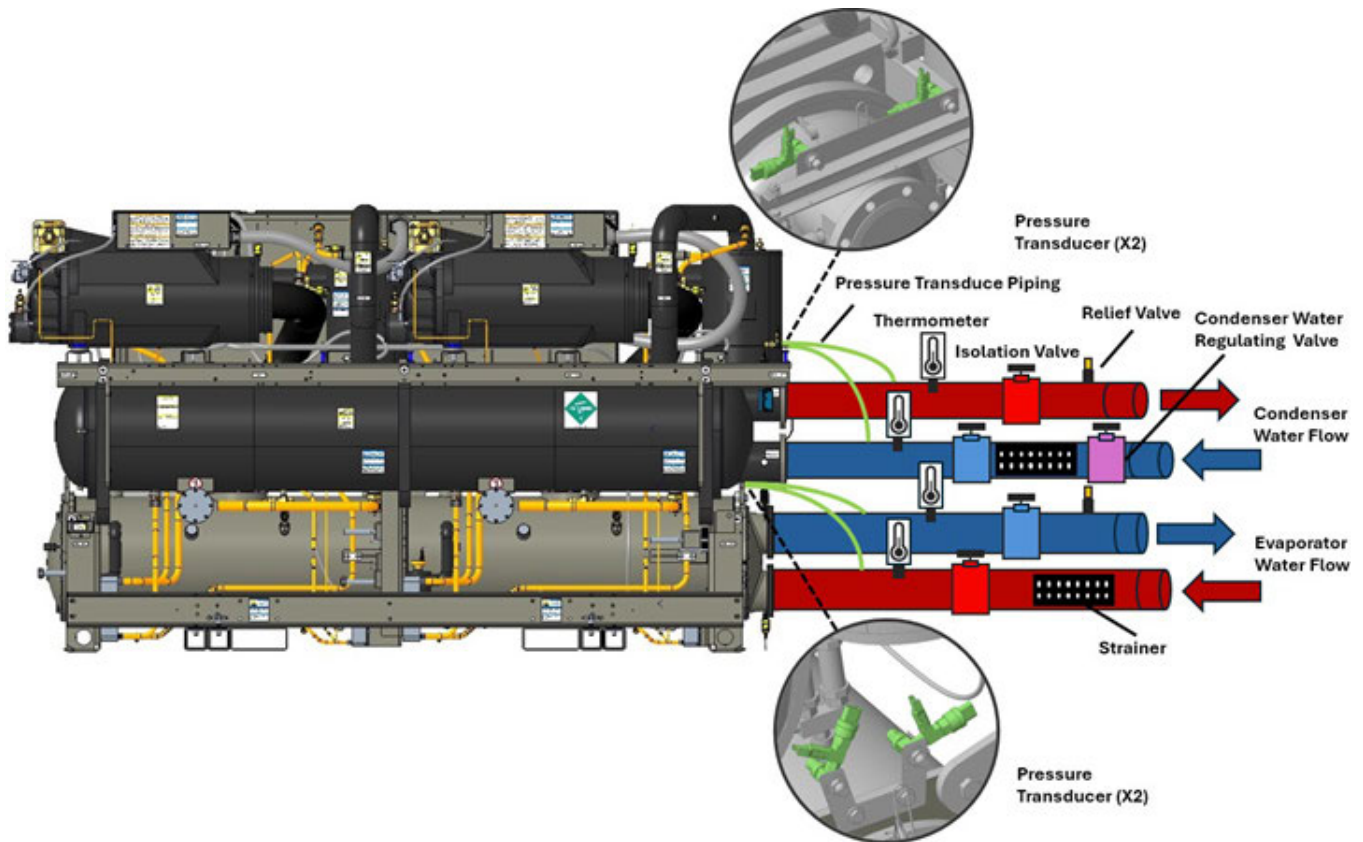

The following components are required for every installation.

### Water Isolation Valve

Install an isolation valve on each water pipe connected to the unit for servicing or isolating customer side water.

### Thermometer

Thermometers may be installed in entering and leaving water lines to monitor temperatures.

### Pipe Strainer

A pipe strainer is required in the entering water line to prevent water-borne debris from entering the evaporator or condenser.

### Water Pressure Relief Valves

It is the user's or a designated agent's responsibility to identify all potential overpressure scenarios and the method of overpressure protection for their water/fluid circulation systems. Before operation, install a pressure relief valve or suitable pressure relieving system in the condenser and evaporator fluid piping to protect the vessels and piping from over pressurization. Systems with shutoff valves close coupled to the vessels have the potential for hydrostatic pressure buildup on water temperature increase and location of relief valves and/or bypass arrangements can be critical.

Pressure relief flow rates and installed pressure relief valves should consider an evaluation of the complete hydronic system to which each vessel is attached, inclusive of all valves and attached components, interconnecting piping, operating parameters and controls. Relief valve installation shall be consistent with local codes and regulations, the ASME Boiler and Pressure Vessel Code, Section VIII Division 1 (ASME BPVC VIII-1) or Boiler, Pressure Vessel and Pressure Piping Code, CSA B51, as applicable.

Only RTZA condensers are certified to ASME BPVC VIII-1 code standards on the waterside of the heat exchanger. ASME BPVC VIII-1 requires that certified vessels be installed with pressure relief of sufficient capacity to avoid overpressure in the unlikely case of an internal heat exchanger failure. API (American Petroleum Institute) 521, Pressure-relieving and decreased-pressure systems, is an industry standard that provides a basic methodology for calculating a theoretical pressure relief flow



## Installation – Mechanical

---

rate for heat exchanger internal failure in the form of a complete tube rupture. According to this methodology, it is recommended that the following relief flow rates estimated for internal tube failure of the RTZA condenser be considered when water side relief devices are selected and installed. API 521 further recommends consideration of the relieving capacity of the attached piping system which may eliminate the need for a relieving device for the vessel or reduce relief flow requirements.

**Table 12. Recommended relief flow rates**

Condenser shell-side pressure	Internal failure relief flow estimate (at 10% allowable over pressure)
270 psig (High Pressure Cutout)	295 gpm
300 psig (Vessel MAWP)	309 gpm

### **NOTICE**

#### **Equipment Damage!**

**Do not exceed 150 psig condenser water pressure as it could result in damage to the condenser or regulating valve.**

## Reversing Waterboxes

### **NOTICE**

#### **Equipment Damage!**

Altering waterboxes can affect equipment operation and can cause equipment damage.

Do **NOT** rotate or swap evaporator or condenser waterboxes end-for-end.

Waterboxes on the evaporator and condenser **cannot** be rotated or swapped end for end. Altering waterboxes will lead to poor efficiency, poor oil management and possible freeze-up of evaporator.

Waterboxes must be installed with a vertical orientation. Verify the waterbox is not installed at an angle. See the figures below for correct and the incorrect waterbox installation orientation.

**Figure 33. Waterbox – left**

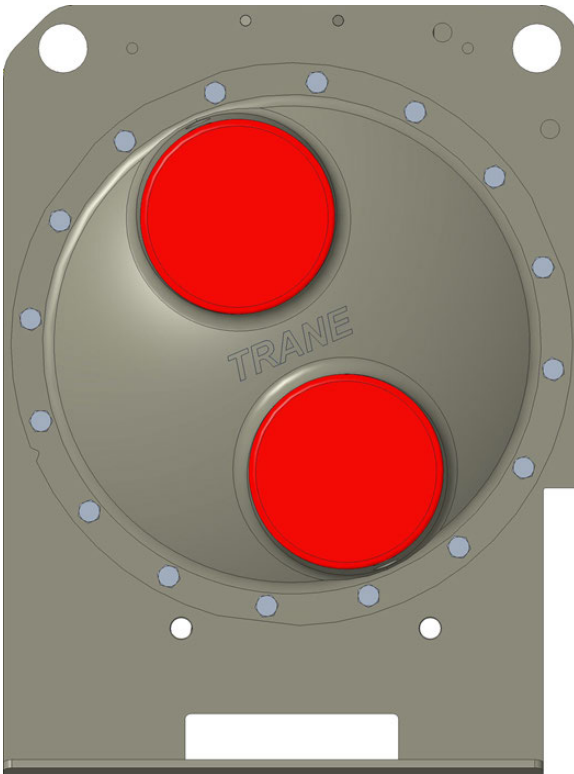

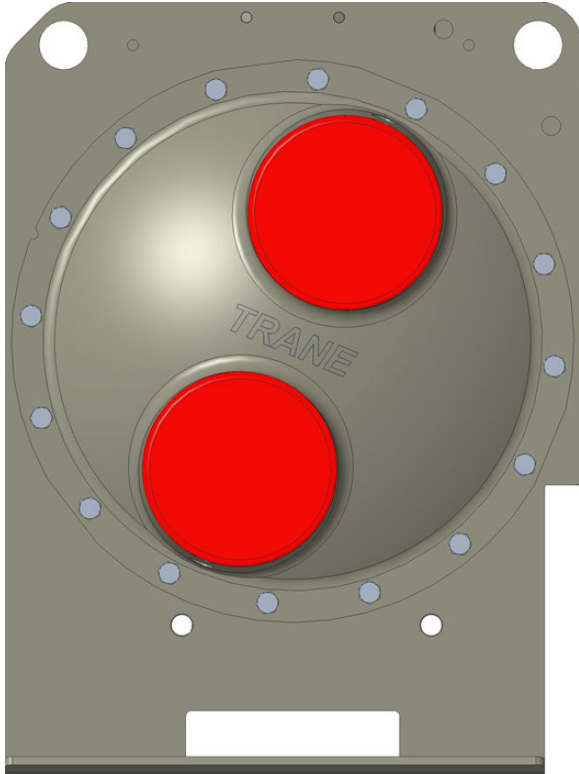
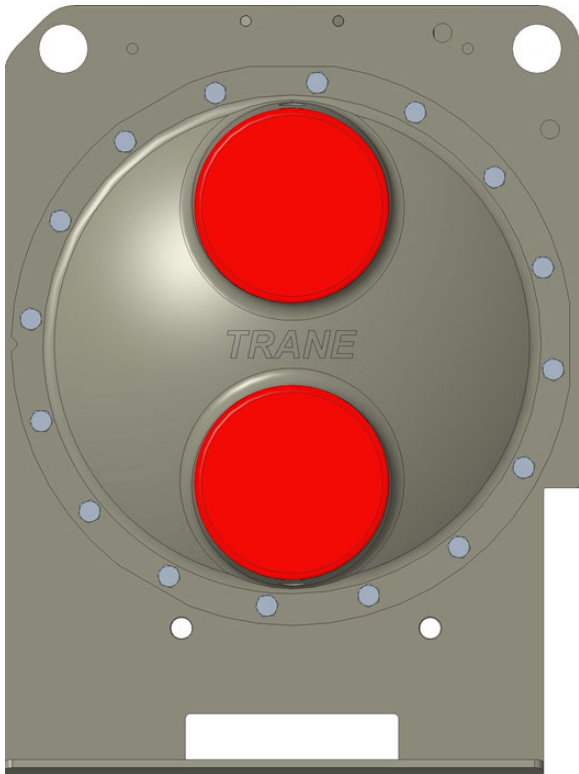
**Figure 34. Waterbox – right****Figure 35. Waterbox – correct**

## Waterbox Drain and Vents

### NOTICE

#### Waterbox Damage!

Failure to follow instructions could result in damage to the waterbox.

**Do not over-tighten or use excessive Teflon® pipe tape when installing valves, drains, plugs and vents on waterboxes.**

Drains and vents are located on each evaporator and condenser waterbox. When the unit is shipped, the drain plugs are removed and placed in a plastic bag in the control panel. Each drain and vent must be piped with a shutoff valve, or the original plug reinstalled, prior to water pump operation.

To completely drain the condenser or evaporator shell, remove bottom drain plugs and top vent plugs.

**Figure 36. Waterbox vent and drain port locations**

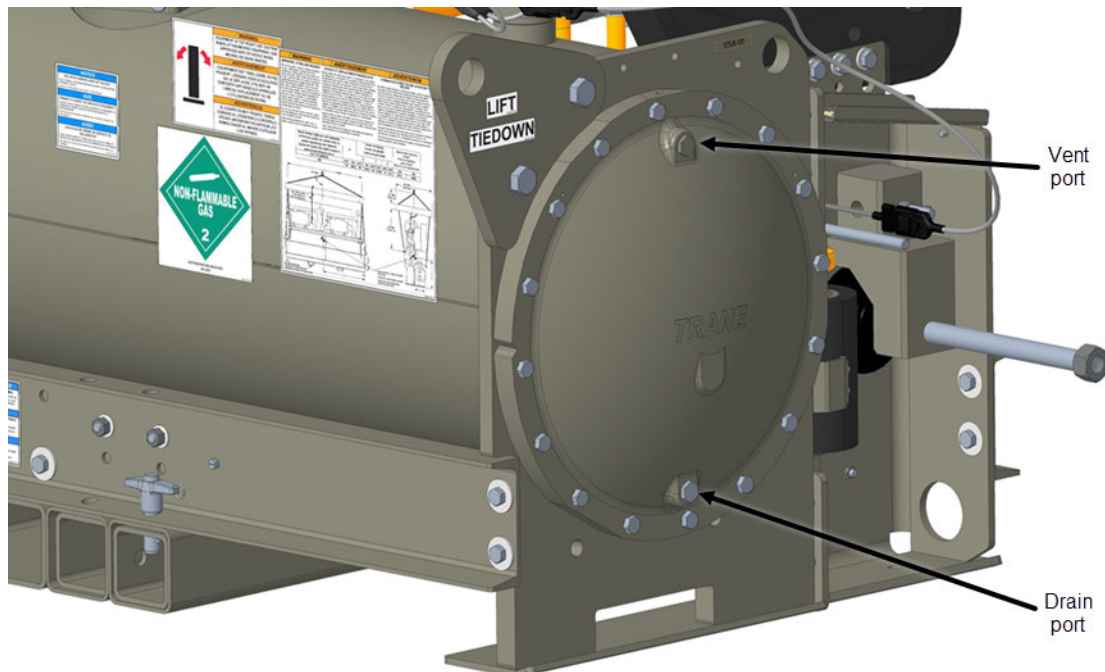

## Pressure Transducer

### NOTICE

#### Evaporator Damage!

Failure to follow instructions could result in evaporator damage.

**To prevent evaporator damage, do not use water flow switch to cycle the system.**

This heat pump unit comes standard with two pressure transducers located and mounted above the condenser and evaporator water boxes (see “Water Piping,” p. 45). These pressure transducers supply both flow proving and flow measurement. It is the customer’s responsibility to connect these pressure transducers to the corresponding entering and leaving water piping of the customer’s attached piping system.

Connection can be made using suitable forms of tubing or pipe and standard plumbing connections/fittings. It is recommended that these pressure transducer connections are made at least five pipe diameters from the connection to the heat pump to confirm accurate readings.

Each unit requires calibration between flow and differential pressure. Although it is shipped with a factory default setting, it should be field-calibrated after final installation to account for installation- and application-specific conditions. This provides the most accurate flow reading. The calibration procedure is described in “Flow Calibration,” p. 73.

It is important to note that at least one psi differential pressure between inlet and outlet pressure transducers must be obtained at any operating flow rate within the allowable range (see “General Data,” p. 13) to verify accurate sensing of the presence of



## Installation – Mechanical

water flow. Additional piping, a reducer, a valve, or other components may be added so that adequate pressure drop can be measured at the lowest operating flow rate.

Table 13, p. 52 and Table 14, p. 52 contain reference values for the "Flow Proving" and "Flow Warning" conditions.

**Table 13. Condenser flow proving and warning**

Condenser	Tube Type	GPM		60% Minimum GPM	75% Minimum GPM
		Min	Max	Flow Proving	Flow Warning
2 Pass	90/10 CuNi	150	890	90	112.5
2 Pass Low Flow	90/10 CuNi	125	670	75	93.75

**Table 14. Evaporator flow proving and warning**

Evaporator	GPM		60% Minimum GPM	75% Minimum GPM
	Minimum	Maximum	Flow Proving	Flow Warning
2 Pass	250	877	150	187.5
3 Pass	160	585	96	120

## Water Regulating Valve

The Condenser Head Pressure Control Option provides for a 0 to 10V (maximum range - a smaller range is adjustable) output interface to the customer's condenser water flow device. See *Condenser Water Temperature Control Water-Cooled Series R® Chillers Model RTZA Engineering Bulletin* (RLC-PRB061\*-EN) for further details regarding condenser water temperature control.

The following guidelines must be met for adequate oil circulation throughout the system.

- The RTZA requires a minimum pressure differential of 25 psid (172.1 kPa) at all load conditions to maintain proper oil circulation. This is only a concern during startup, as the operating map provides a pressure differential greater than 35 psid (241.3 kPa) during all operating conditions.
- At startup, condenser entering water temperature must be greater than or equal to evaporator entering water temperature. Typically, evaporator entering water temperature falls within the range of 80 to 120°F + full load evaporator waterside ΔT.

## Pressure Drop Curves

Figure 37. Condenser waterside pressure drop

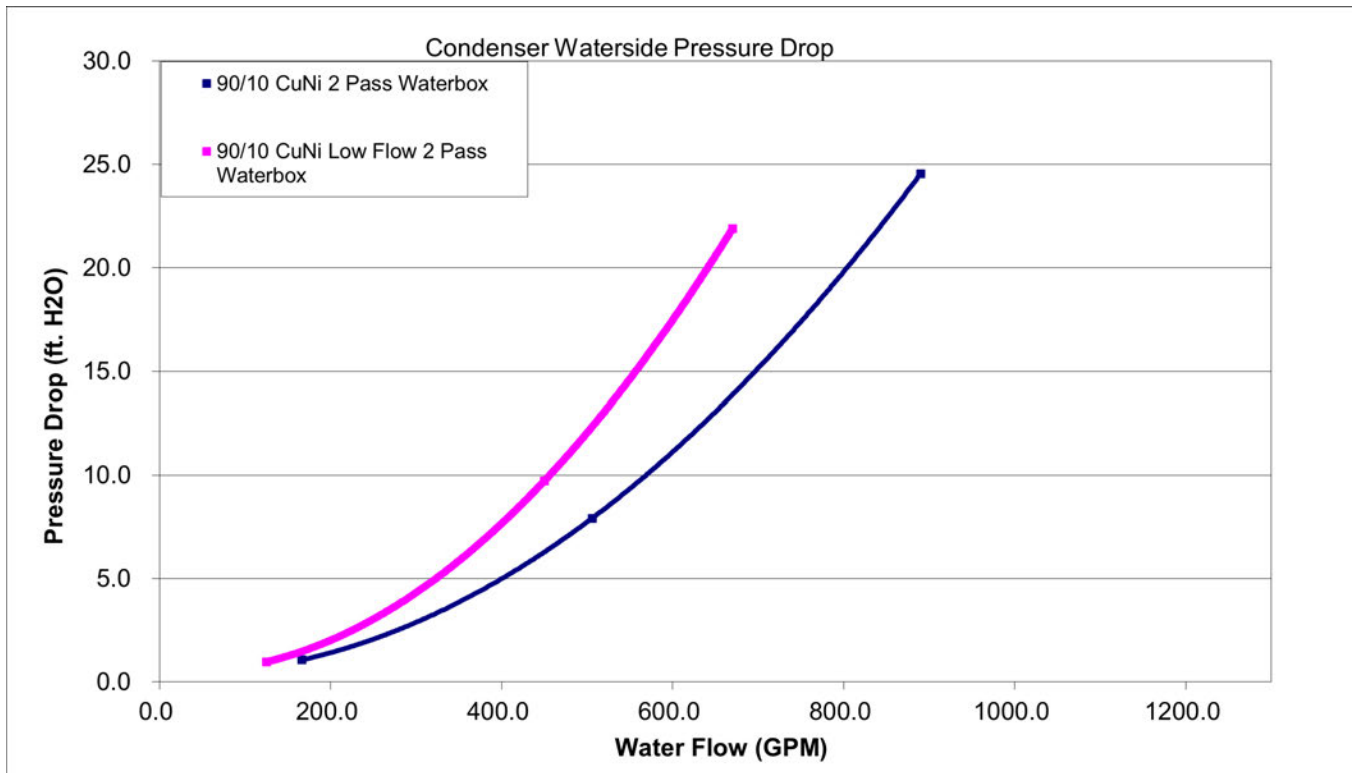

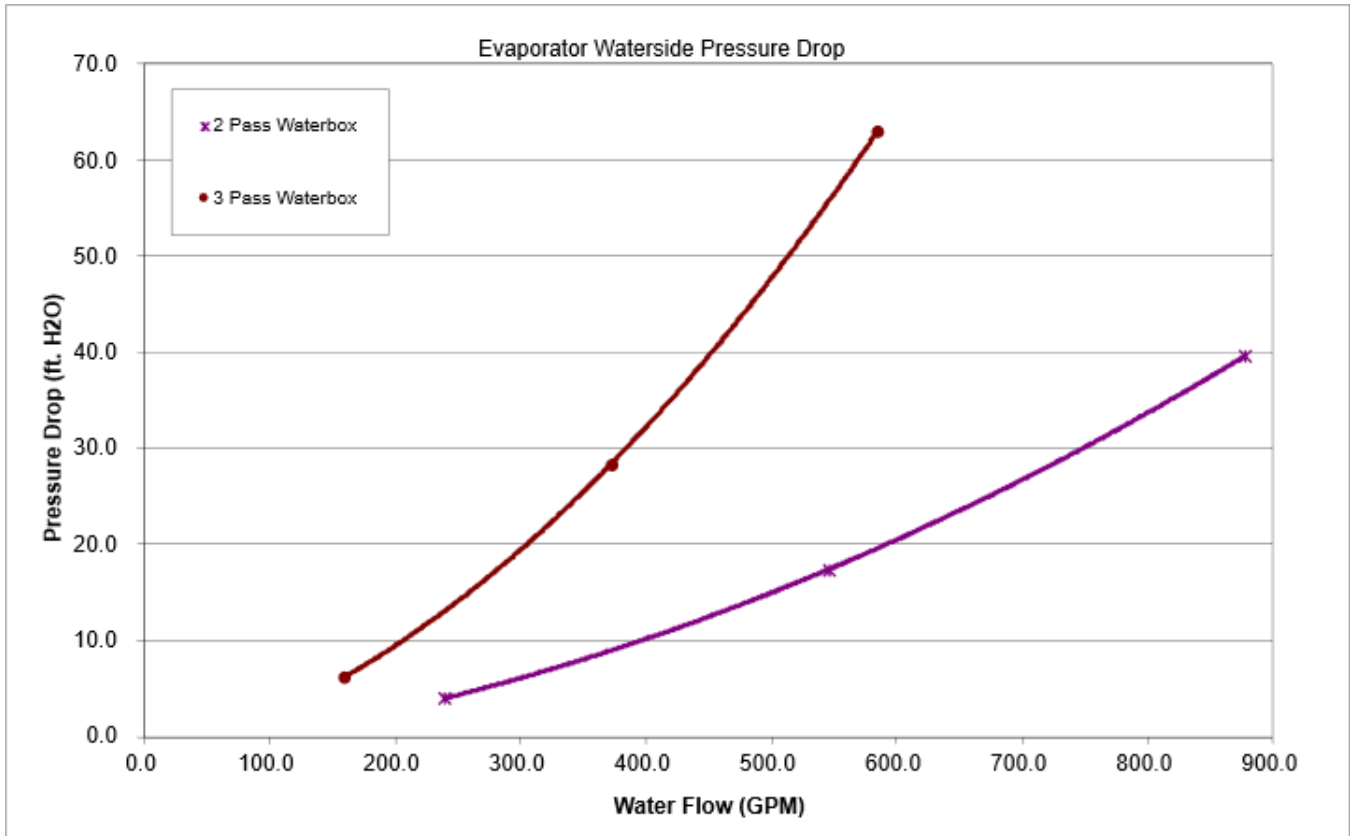
**Figure 38. Evaporator waterside pressure drop**

## Water Treatment

### NOTICE

#### Proper Water Treatment Required!

The use of untreated or improperly treated water could result in scaling, erosion, corrosion, algae or slime.

Use the services of a qualified water treatment specialist to determine what water treatment, if any, is required. Trane assumes no responsibility for equipment failures which result from untreated or improperly treated water, or saline or brackish water.

**Important:** If using an acidic commercial flushing solution, construct a temporary bypass around the unit to prevent damage to internal components of the evaporator and condenser.

Dirt, scale, products of corrosion, and other foreign material will adversely affect heat transfer between the water and system components. Foreign matter in the chilled water system can also increase pressure drop and, consequently, reduce water flow. Proper water treatment must be determined locally, depending on the type of system and local water characteristics.

Neither salt nor brackish water is recommended for this unit. Use of either will lead to a shortened life to an indeterminable degree. Trane Technologies encourages to have a reputable water treatment specialist, familiar with local water conditions, to assist in this determination and in the establishment of a proper water treatment program.

Using untreated or improperly treated water in these units may result in inefficient operation and possible tube damage. Consult a qualified water treatment specialist to determine whether treatment is needed.

## Low Evaporator Refrigerant Cutout, Percent Glycol Requirements

Under normal conditions, the unit operates at temperatures that prevent water freezing in the evaporator. If abnormal conditions cause risk of freezing, the low suction pressure cutout prevents operation. This built-in protection eliminates the need for glycol, so detailed information is not provided. Glycol use is permissible, but not required.

Glycol will adversely affect unit performance. The unit efficiency will be reduced and the saturated evaporator temperature will be reduced. For some operating conditions this effect can be significant.

## Refrigerant Relief Valve Venting

### ⚠ WARNING

#### Refrigerant under High Pressure!

Failure to follow instructions below could result in an explosion which could result in death or serious injury or equipment damage.

System contains oil and refrigerant under high pressure. Recover refrigerant to relieve pressure before opening the system. See unit nameplate for refrigerant type. Do not use non-approved refrigerants, refrigerant substitutes, or refrigerant additives.

### NOTICE

#### Equipment Damage!

To prevent shell damage, install pressure relief valves in both the evaporator and condenser water systems.

### NOTICE

#### Equipment Damage!

Failure to comply with specifications may result in capacity reduction, unit damage and/or relief valve damage. Do NOT exceed vent piping code specifications!

All units utilize a condenser and evaporator refrigerant-pressure relief valve for each circuit which must be vented to the outdoor atmosphere.

The valves are located at the top of the condenser and evaporator. Each valve contains a threaded fitting for a sealed piping connection.

High side relief valve discharge setpoint is 300 psig. Once the relief valve is opened, it will re-close when pressure is reduced to a safe level.

**Note:** Refer to local codes for relief valve vent line sizing requirements. The vent line length must not exceed code recommendations. If the line length will exceed code recommendations for the outlet size of the valve, install a vent line of the next larger pipe size.

Pipe each relief valve on the unit into a common vent line. Provide an access valve located at the low point of the vent piping, to enable draining of any condensate that may accumulate in the piping.

If multiple chillers are installed, each unit may have separate venting for its relief valves. If multiple relief valves are vented together, see ASHRAE 15, and/or local codes for sizing requirements.

**Note:** Refer to Figure 3 for the condenser relief valve location and Figure 4 for the evaporator relief valve location.

Figure 39. Refrigerant piping

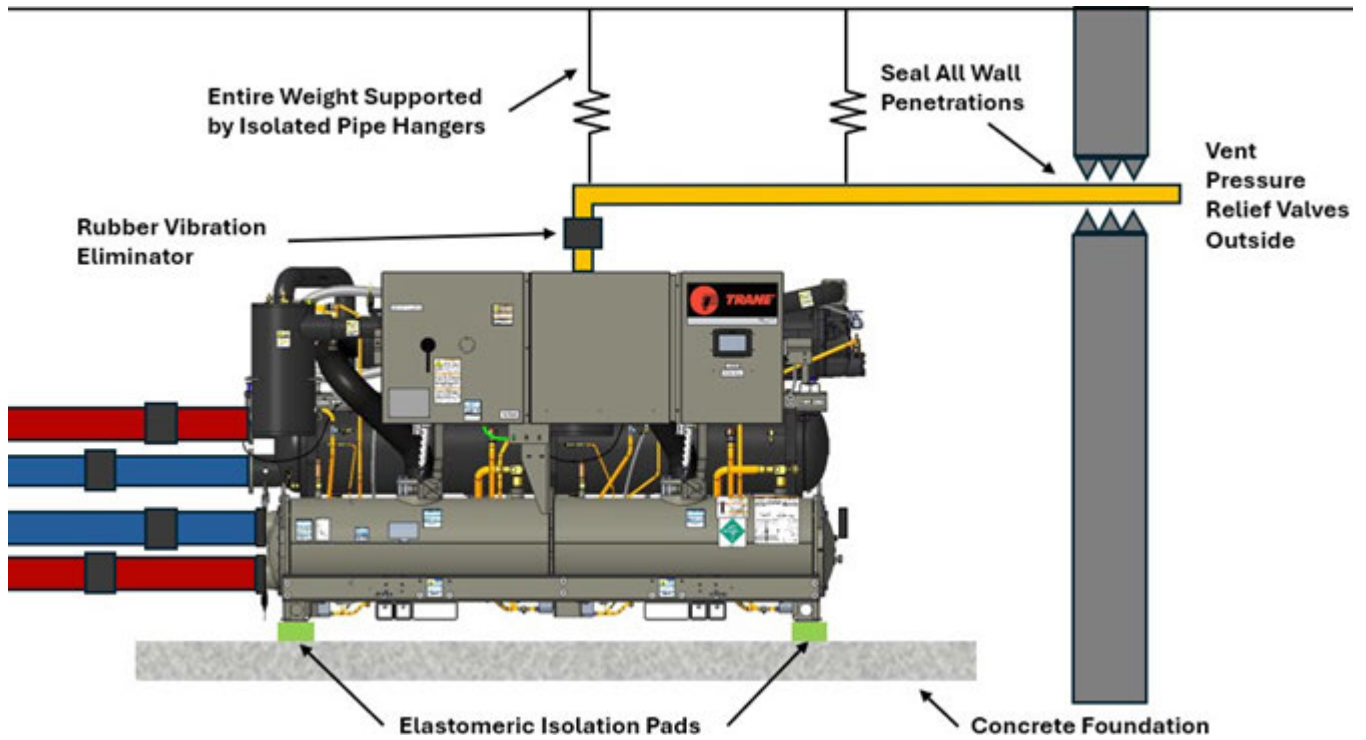

### Summary of Relief Valves

Table 15. Relief valve descriptions

	Condenser	Evaporator
Units	High Pressure Side	Low Pressure Side
Relief Setpoint	300 psig	200 psig
Quantity (standard)	1 per circuit	1 per circuit
Quantity (Dual Relief Valves option)	2 per circuit	2 per circuit
Relief Rate (lb/min) Per Valve	25.4	28.9
Field Connection Size	5/8 in. MFL	3/4 in. NPTFI



# Installation – Electrical

## General Recommendations

As you review this manual, keep in mind that:

- All field-installed wiring must conform to National Electric Code (NEC) guidelines, and any applicable state and local codes. Be sure to satisfy proper equipment grounding requirements per NEC.
- Compressor motor and unit electrical data (including motor kW, voltage utilization range, rated load amps) is listed on the chiller nameplate.
- All field-installed wiring must be checked for proper terminations, and for possible shorts or grounds.

**Note:** Always refer to wiring diagrams shipped with chiller or unit submittal for specific electrical schematic and connection information.

### ⚠ WARNING

#### Hazardous Voltage!

Failure to disconnect power before servicing could result in death or serious injury.

Disconnect all electric power, including remote disconnects before servicing. Follow proper lockout/tagout procedures to ensure the power can not be inadvertently energized. Verify that no power is present with a voltmeter.

### ⚠ WARNING

#### Proper Field Wiring and Grounding Required!

Failure to follow code could result in death or serious injury.

All field wiring **MUST** be performed by qualified personnel. Improperly installed and grounded field wiring poses **FIRE** and **ELECTROCUTION** hazards. To avoid these hazards, you **MUST** follow requirements for field wiring installation and grounding as described in NEC and your local/state/national electrical codes.

### NOTICE

#### Use Copper Conductors Only!

Failure to use copper conductors could result in equipment damage as the equipment was not designed or qualified to accept other types of conductors.

**Important:** Do not allow conduit to interfere with other components, structural members, or equipment. Control voltage (115V) wiring in conduit must be separate from conduit carrying low voltage (<30V) wiring. To prevent control malfunctions, do not run low voltage wiring (<30V) in conduit with conductors carrying more than 30 volts.

## Installer-Supplied Components

Customer wiring interface connections are shown in the electrical schematics and connection diagrams that are shipped with the unit. The installer must provide the following components if not ordered with the unit:

- Power supply wiring (in conduit) for all field-wired connections.
- All control (interconnecting) wiring (in conduit) for field supplied devices.
- Fused-disconnect switches or circuit breakers.

## Power Supply Wiring

### ⚠ WARNING

#### Hazardous Voltage!

Failure to disconnect power before servicing could result in death or serious injury.

Disconnect all electric power, including remote disconnects before servicing. Follow proper lockout/tagout procedures to ensure the power can not be inadvertently energized. Verify that no power is present with a voltmeter.



**⚠ WARNING**

**Hazardous Voltage!**

Failure to disconnect power before servicing could result in death or serious injury.

Disconnect all electric power, including remote disconnects before servicing. Follow proper lockout/tagout procedures to ensure the power can not be inadvertently energized. Verify that no power is present with a voltmeter.

All power supply wiring must be sized and selected accordingly by the project engineer in accordance with NEC Table 310.15(B) (16); formerly Table 310-16.

All wiring must comply with local codes and the National Electrical Code. The installing (or electrical) contractor must provide and install the system interconnecting wiring, as well as the power supply wiring. It must be properly sized and equipped with the appropriate fused disconnect switches.

The type and installation location(s) of the fused disconnects must comply with all applicable codes.

Knock-outs for wiring are located on the upper left side of the high voltage control panel. The wiring is passed through these conduits and connected to the HACR type breakers. Refer to “Unit Connection Locations,” p. 23.

To provide proper phasing of 3-phase input, make connections as shown in field wiring diagrams and as stated on the NOTICE label inside the high voltage power panel. For additional information on proper phasing, refer to **Unit Voltage Phasing**. Proper equipment ground must be provided to each ground connection in the panel (one for each customer-supplied conductor per phase). 115 volt field-provided connections (either control or power) are made through knockouts on the right side of the low voltage power panel. Refer to “Unit Connection Locations,” p. 23. Additional grounds may be required for each 115 volt power supply to the unit. A terminal strip is provided for 115V customer wiring.

**Control Power Supply**

The unit is equipped with a control power transformer. Additional control power voltage to the unit is not necessary. No other loads should be connected to the control power transformer.

All units are factory-connected for appropriate labeled voltages.

**Interconnecting Wiring**

Refer to Field Wiring Diagram (2311-6698) for modules and terminals identification.

**Condenser and Chilled Water Pump Control**

The Condenser Water Pump (CWP) and Evaporator Water Pump (EWP) contactors are controlled by two relay outputs located on the Condenser and Chilled Water Pump Relays board. These relay contacts must be compatible with 115/240 VAC control circuits.

The pump relays operate based on chiller control logic, Tracer® commands (if connected), or service pumpdown mode (see the Maintenance chapter). Under normal conditions, both pump relays follow the chiller’s AUTO mode.

When the chiller transitions from Stop to Auto:

1. The EWP relay energizes first.
2. When evaporator water flow is proven, the CWP relay energizes.
3. When condenser water flow is confirmed, the heat pump proceeds with the next step in the start sequence.

When the chiller is in AUTO mode and no diagnostics are active, both normally open pump relays remain energized, regardless of the source of the AUTO command.

When the chiller exits AUTO mode, both pump relays open after a user adjustable time delay (0–30 minutes via Tracer® TU). In non AUTO modes—Reset, Stop, External Stop, Remote Display Stop, or Stopped by Tracer—both pumps remain off.

It is critical that a pump starts whenever the chiller commands it. Failure to provide water flow when required can cause severe evaporator or condenser damage. The installing contractor and/or customer must confirm proper pump operation under all commanded conditions.

**Table 16. Pump relay operation**

Chiller Mode	Relay Operation
Auto	Instant close
Tracer Override	Close

**Table 16. Pump relay operation (continued)**

Chiller Mode	Relay Operation
Stop	Timed Open
Diagnostics (immediate shutdown)	Instant Open
Diagnostics (normal shutdown)	Timed Open

If, during a transition from Stop to Auto, condenser or evaporator water flow is not established within 20 minutes, the controller de-energizes the associated pump and generates a non-latching diagnostic. If flow is restored (for example, if another system enables the pump), the diagnostic clears, the pump is re-energized, and normal operation resumes.

If water flow is lost after being previously established, the pump relay remains energized and a non-latching diagnostic is issued. When flow returns, the diagnostic clears automatically and the chiller resumes normal operation.

In most cases, any latching or non-latching diagnostic causes the pump relay to turn off immediately (zero delay).

Exceptions: situations where the relay remains energized:

- Low condenser refrigerant temperature
- Low evaporator refrigerant temperature
- Low evaporator water temperature
- Starter contactor interrupt failure (compressor current continues after a shutdown command)
- Loss of water flow diagnostic

## Alarm and Status Relay Outputs (Programmable Relays)

A programmable relay concept provides for enunciation of certain events or states of the heat pump, selected from a list of likely needs, while only using four physical output relays, as shown in the field wiring diagram. The four relays are provided (generally with a Quad Relay Output LLID) as part of the Alarm Relay Output Option. The relay contacts are isolated Form C (SPDT), suitable for use with 120 Vac circuits drawing up to 2.8 amps inductive, 7.2 amps resistive, or 1/3 HP, and for 240 Vac circuits drawing up to 0.5 amp resistive. The list of events/states that can be assigned to the programmable relays can be found in the following table. The relay will be energized when the event/state occurs.

**Table 17. Alarm and status relay output configuration**

Alarm	Description
Latching Alarm	This output is true whenever there is any active latching shutdown diagnostic that targets the Unit, Circuit, or any of the Compressors on a circuit.
Non-latching Alarm	This output is true whenever there is any active non-latching shutdown diagnostic that targets the Unit, Circuit, or any of the Compressors on a circuit.
Alarm	This output is true whenever there is any active latching or non-latching shutdown diagnostic that targets the Unit, Circuit, or any of the Compressors on a circuit.
Alarm Circuit 1	This output is true whenever there is any active latching or non-latching shutdown diagnostic that targets Circuit 1, or any of the Compressors on Circuit 1.
Alarm Circuit 2	This output is true whenever there is any active latching or non-latching shutdown diagnostic that targets Circuit 2, or any of the Compressors on Circuit 2.
Chiller Limit Mode	This output is true whenever a circuit on the Chiller has been running in one of the limit modes continuously for the Limit Relay debounce time. A given limit or overlapping of different limits must be in effect continuously for the debounce time prior to the output becoming true. It will become false if no limits are present for the debounce time.
Compressor Running	The output is true whenever any compressor is running.
Circuit 1 Running	The output is true whenever any compressor of Circuit 1 is running.
Circuit 2 Running	The output is true whenever any compressor of Circuit 2 is running.
Warning	The output is true whenever there is any active warning diagnostic that is associated with the Unit, Circuit, or any of the compressors on a circuit.
Max Capacity	The output is true whenever the unit has reached maximum capacity continuously for the Max Capacity Relay debounce time. The output is false when the unit is not at maximum capacity continuously for the filter debounce time. See the Max Capacity Relay specification for more information.



## Installation – Electrical

**Table 17. Alarm and status relay output configuration (continued)**

Alarm	Description
Evaporator Freeze Avoidance Request	This relay output is energized any time either the Low Evaporator Water Temperature – Unit Off or the Low Evaporator Temperature Circuit x – Unit Off diagnostics are active. This relay is intended for use as an external interlock for a field engineered and provided solution to mitigate the freeze danger implied by these diagnostics. Generally, this would be used in cases where operation of the evaporator water pump is unacceptable due to the system constraints, (i.e. such as mixing unconditioned warm water with controlled supply water as provided by other parallel Chillers. The relay's output can provide the method to close bypass valves so the circulation becomes local to the evap and excludes the load, or can be used to defeat the evap pump override entirely while initiating an independent source of heat / flow to the evap.
Service Request	This relay will be energized when at least one Maintenance alert condition (refer to Service required message specification) occurs, as long as at least one of associated informational diagnostic(s) will be active.
Condenser Freeze Avoidance Request	The Condenser Freeze Avoidance Request Relay will indicate when the condenser water pump is being commanded on in an override mode – this relay can provide therefore, the means of wiring additional pump, bypass valves, or to defeat the Condenser Pump Override, so as to still provide the necessary heat flow into the condenser to avoid a freeze.
Alarm – General Latching Unit	This output is true whenever there is latching alarm(s) that targets chiller or all circuits or all the compressors on a circuit so that the unit is unable to produce any capacity. It means that it activates when there is latching alarm on Chiller or 'General Latching Circuit X' on every circuits.
Alarm – General Non Latching Unit	This output is true whenever there is at least a non-latching alarm(s) that targets chiller or circuits or compressors on a circuit and there are latching or/and non-latching diagnostics that targets chiller, circuits or compressors so that the unit is unable to produce any capacity.
Alarm – General Latching Circuit 1	This output is true whenever there is latching alarm(s) that targets Circuit 1 or all the compressors on Circuit 1 so that the Circuit 1 is unable to produce any capacity. It means that it activates when there is latching alarm on circuit or latching alarms on every compressors of circuit.
Alarm – General Non Latching Circuit 1	This output is true whenever there is non-latching alarm(s) that targets Circuit 1 or the compressors on Circuit 1 so that the Circuit 1 is unable to produce any capacity.
Alarm – General Latching Circuit 2	This output is true whenever there is latching alarm(s) that targets Circuit 2 or all the compressors on Circuit 2 so that the Circuit 2 is unable to produce any capacity. It means that it activates when there is latching alarm on circuit or latching alarms on every compressors of circuit.
Alarm – General Non Latching Circuit 2	This output is true whenever there is non-latching alarm(s) that targets Circuit 2 or the compressors on Circuit 2 so that the Circuit 2 is unable to produce any capacity.
Head Pressure Relief Request	This relay output is energized anytime the chiller or a single circuit on the chiller is running in one of the following modes: Ice Making Mode, or Condenser Pressure Limit continuously for the duration specified by the Chiller Head Relief Relay Filter Time. The Chiller Head Relief Relay Filter Time is a service setpoint. The relay output is de-energized anytime the chiller exits all above modes continuously for the duration specified by the same Chiller Head Relief Relay Filter Time.

**Note:** “Chiller” in the codes above is synonymous with “heat pump”.

### Relay Assignments

The Tracer® TU service tool is used to install the Alarm and Status Relay Option package and assign any of the above list of events or status to each of the four relays provided with the option. The relays to be programmed are referred to by the relay terminal numbers on the LLID board 1A13. The default assignments for the four available relays of the Alarm and Status Package Option are: If any of the Alarm/Status relays are used, provide electrical power, 115 Vac with fused-disconnect to the panel and wire through the appropriate relays/terminals on 1A13. Provide wiring (switched hot, neutral, and ground connections) to the remote annunciation devices.

Do not use power from the heat pump's control panel transformer to power these remote devices. Refer to the field diagrams which are shipped with the unit.

**Table 18. Default assignments**

Relay	Assignment
Relay 1 Terminals J2 - 1, 2, 3	Evaporator Water Freeze Avoidance Request
Relay 2 Terminals J2 - 4, 5, 6	Condenser Water Freeze Avoidance Request
Relay 3 Terminals J2 - 7, 8, 9	Compressor Running
Relay 4 Terminals J2 - 10, 11, 12	Latching Alarm

## Low Voltage Wiring

### ⚠ WARNING

#### Proper Field Wiring and Grounding Required!

Failure to follow code could result in death or serious injury.

All field wiring **MUST** be performed by qualified personnel. Improperly installed and grounded field wiring poses **FIRE** and **ELECTROCUTION** hazards. To avoid these hazards, you **MUST** follow requirements for field wiring installation and grounding as described in NEC and your local/state/national electrical codes.

#### Important:

1. The remote devices described below require low voltage wiring. All wiring to and from these remote input devices to the Control Panel must be made with shielded, twisted pair conductors. Be sure to ground the shielding only at the panel.
2. To prevent control malfunctions, do not run low voltage wiring (<30 V) in conduit with conductors carrying more than 30 volts.

### Emergency Stop

The unit controller provides auxiliary control for a customer-specified or customer-installed latching trip out. When this customer-furnished remote contact is provided, the chiller will run normally when the contact is closed. When the contact opens, the unit will trip on a latching diagnostic. This latched condition requires either a manual reset at the front of the control panel or a power cycle of the unit controller to clear.

Connect low voltage leads to Emergency Stop terminal strip locations on External Auto-Stop and Emergency Stop Inputs LLID board. Refer to the field diagrams that are shipped with the unit.

Silver or gold-plated contacts are recommended. These customer-furnished contacts must be compatible with 24 Vdc, 12 mA resistive load.

### External Auto/Stop

If the unit requires the external Auto/Stop function, the installer must provide leads from the remote contacts to the External Auto-Stop terminals of the External Auto-Stop and Emergency Stop Inputs LLID board in on the control panel.

The chiller will run normally when the contacts are closed. When either contact opens, the compressor(s), if operating, will go to the RUN:UNLOAD operating mode and cycle off. Unit operation will be inhibited. Closure of the contacts will permit the unit to return to normal operation.

Field-supplied contacts for all low voltage connections must be compatible with dry circuit 24 Vdc for a 12 mA resistive load. Refer to the field diagrams that are shipped with the unit.

### External Water Setpoint Option

The unit controller provides inputs that accept either 4 to 20 mA or 2 to 10 VDC signals to set the external water setpoint. There is one analog input for external hot water setpoint and another input for chilled water setpoint. The input is primarily used with a generic building automation systems (BAS). Each water setpoint is set using the Tracer® AdaptiView™ TD-7 or through digital communication. The arbitration of the various water setpoint sources is described in the flow charts below. Each setpoint may be changed from a remote location by sending either a 2 to 10 VDC or 4 to 20 mA signal.

#### External Hot Water Setpoint (EHWS)

External hot water setpoint can be wired to “External Demand Limit and Hot Water Inputs” analog input module. The analog input signal corresponds to the configurable range, which is adjustable in Tracer TU.

#### External Chilled Water Setpoint (ECWS)

External chilled water setpoint can be wired to “External Chilled Water Setpoint and Unused Inputs” analog input module. The analog input signal corresponds to the configurable range, which is adjustable in Tracer TU.

**Table 19. Default minimum and maximum values**

External Water Setpoint	Default Temperature	
	Minimum – °F (°C)	Maximum – °F (°C)
Hot (EHWS)	155 (68.3)	215 (101.7)
Chilled (ECWS)	68 (20)	122 (50)



## Installation – Electrical

The equations below apply if using default minimum and maximum values, as shown in table above.

**Table 20. External hot water setpoint equations – default minimum and maximum values**

External Hot Water Setpoint (°F)		
As generated from external source	$VDC = 0.1333*(EHWS) - 18.6667$	$mA = 0.2667*(EHWS) - 41.3333$
As processed by unit controller	$EHWS = 7.5*(VDC) + 140$	$EHWS = 3.75*(mA) + 140$
	Voltage Signal	Current Signal

**Table 21. External chilled water setpoint equations – default minimum and maximum values**

External Chilled Water Setpoint (°F)		
As generated from external source	$VDC = 0.1481*(ECWS) - 8.0704$	$mA = 0.2960*(ECWS) - 16.1481$
As processed by unit controller	$ECWS = 6.75*(VDC) + 54.5$	$ECWS = 3.375*(mA) + 54.5$
	Voltage Signal	Current Signal

If minimum and maximum values have been changed from default values, use the following equations:

- For voltage input signal:  $EWS = Min + (Max - Min)*(VDC - 2) / 8$
- For current input signal:  $EWS = Min + (Max - Min)*(mA - 4) / 16$

If the input develops an open or short, the LLID will report either a very high or very low value back to the main processor. This will generate an informational warning and the unit will default to using the front Panel (TD-7) Chilled Water Setpoint.

The Tracer TU Service Tool is used to set the input signal type from the factory default of 2 to 10 VDC to that of 4 to 20 mA. Tracer TU is also used to install or remove the external water setpoint option.

### External Demand Limit Setpoint (EDLS) Option

Similar to above, the controller also provides an optional External Demand Limit Setpoint (EDLS) that will accept either a 2 to 10 VDC (default) or a 4 to 20 mA signal. The demand limit can also be set using the operator display, through digital communication with Tracer® SC+ building automation system, or third party building automation system. The arbitration of the various sources of demand limit is described in the flow charts at the end of this section.

The EDLS may be changed from a remote location by connecting up the analog input signal to the EDLS analog input board. Refer to the following paragraph on Analog Input Signal Wiring Details. The following equations apply for EDLS if using a default minimum of 40% and maximum of 120%.

**Table 22. EDLS voltage and current signals**

Voltage Signal	
Generated from an external source	$VDC = 0.1 (\%) - 2.0$
Processed by the unit controller	$\% = 10*(VDC) + 20$
Current Signal	
Generated from an external source	$mA = 0.2 (\%) - 4.0$
Processed by the unit controller	$\% = 5*(mA) + 20$

If the EDLS input develops an open or short, the LLID will report either a very high or low value back to the main processor. This will generate an informational diagnostic and the unit will default to using the Front Panel Demand Limit Setpoint.

Tracer TU must be used to set the input signal type from the factory default of 2 to 10 VDC to that of 4 to 20 mA current. Tracer TU also need to be used to install or remove the External Demand Limit Setpoint Option for field installation, or can be used to enable or disable the feature (if installed).

### EDLS, EHWS, and ECWS Analog Input Signal Wiring Details

Both the EHWS and EDLS can be connected and set up as either 2 to 10 VDC (factory default) or 4 to 20 mA, as indicated below. Depending on the type to be used, Tracer TU must be used to configure the LLID and the controller for the proper input type that is being used. This is accomplished by a setting change on the Custom Tab of the Configuration View within Tracer TU.

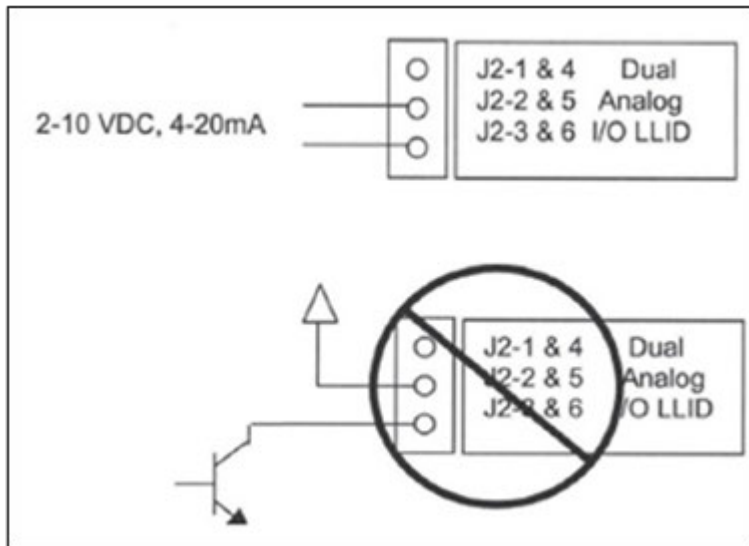
**Figure 40. Wiring examples for EDLS, EHWS, and ECWS**

## Building Automation Systems

### BACnet® Building Automation Control Network

The BACnet control network for Symbio™ 800 expands communications from the unit controls network to the Tracer® Ensemble™ or Tracer® SC+ building automation system (BAS) or third party building automation system. Utilizing BACnet, the BAS allows external setpoint and configuration adjustment and monitoring of status and diagnostics. The Symbio 800 utilizes the BACnet defined TP protocol as defined in ASHRAE standard 135-2004. This controller works in standalone mode, with Tracer Ensemble, Tracer SC+ or when connected to a third party building automation system that supports BACnet.

### Modbus® Automation Control Network

Allows the user to easily interface with Modbus RTU communication protocol via a single twisted pair wiring or Modbus TCP over Ethernet from the Symbio™ 800 controller to a factory installed device.

### LonTalk® Building Automation Systems

The LonTalk communication protocol for the Symbio™ 800 controller expands communications from the unit controls network to a Tracer® Ensemble™ building automation system or third party building automation system. Utilizing LonTalk, the BAS allows external setpoint and configuration adjustment and monitoring of status and diagnostics. The Symbio 800 utilizes an FTT-10A free topology transceiver, which supports non-polarity sensitive, free topology wiring—which in turn allows the system installer to utilize star, bus, and loop architectures. This controller works in standalone mode, peer-to-peer with one or more other units, or when connected to a Tracer Ensemble, Tracer SC+, or a third party building automation system that supports LonTalk.

**Note:** An optional module is required for Symbio 800 support of LonTalk. See Tracer® USB LonTalk Module Installation Instructions (BAS-SVN138\*-EN).



# Controls

## Symbio 800

The Symbio™ 800 controller is a factory-installed, application specific and programmable controller designed to control chillers and large packaged HVAC equipment. A 7-inch user interface features a touch-sensitive color screen that provides facility managers at-a-glance operating status, performance monitoring, scheduling changes, and operating adjustments. Other advanced features include automated controller back-up, and optional features such as secure remote connectivity, wireless building communications, mobile device connectivity, and custom programming with an expandable I/O.

For more information, see *Symbio 800 Controller Installation, Operation, and Maintenance* (BAS-SVX080\*-EN).

## AdaptiView Display

Information is tailored to operators, service technicians, and owners. When operating a chiller, specific information is needed on a day-to-day basis — setpoints, limits, diagnostic information, and reports. This information is provided through the AdaptiView™ display. Logically organized groups of information — chiller modes of operation, active diagnostics, settings and reports put information conveniently at your fingertips.

For more information, see *AdaptiView Display with Symbio™ Controls* (RLC-SVU010\*-EN).

## Tracer TU

The AdaptiView™ TD-7 operator interface allows for daily operational tasks and setpoint changes. However, to adequately service chillers, Tracer® TU service tool is required. (Non-Trane personnel, contact your local Trane office for software purchase information.) Tracer TU adds a level of sophistication that improves service technician effectiveness and minimizes chiller downtime. This portable PC-based service-tool software supports service and maintenance tasks, and is required for software upgrades, configuration changes and major service tasks.

Tracer TU serves as a common interface to all Trane chillers, and will customize itself based on the properties of the chiller with which it is communicating. Thus, the service technician learns only one service interface.

The panel bus is easy to troubleshoot using LED sensor verification. Only the defective device is replaced. Tracer TU can communicate with individual devices or groups of devices.

All chiller status, machine configuration settings, customizable limits, and up to 100 active or historic diagnostics are displayed through the service-tool software interface.

LEDs and their respective Tracer TU indicators visually confirm the availability of each connected sensor, relay, and actuator.

Tracer TU is designed to run on a customer's laptop, connected to the Symbio™ 800 control panel with a USB cable. See *Tracer TU Service Tool User Guide* (BAS-SVU046\*-EN) for laptop requirements.

### Notes:

- *Tracer TU is designed and validated for this minimum laptop configuration. Any variation from this configuration may have different results. Therefore, support for Tracer TU is limited to only those laptops with the configuration previously specified.*
- *For more information, see Tracer TU Service Tool User Guide (BAS-SVU046\*-EN).*

Figure 41. Tracer TU

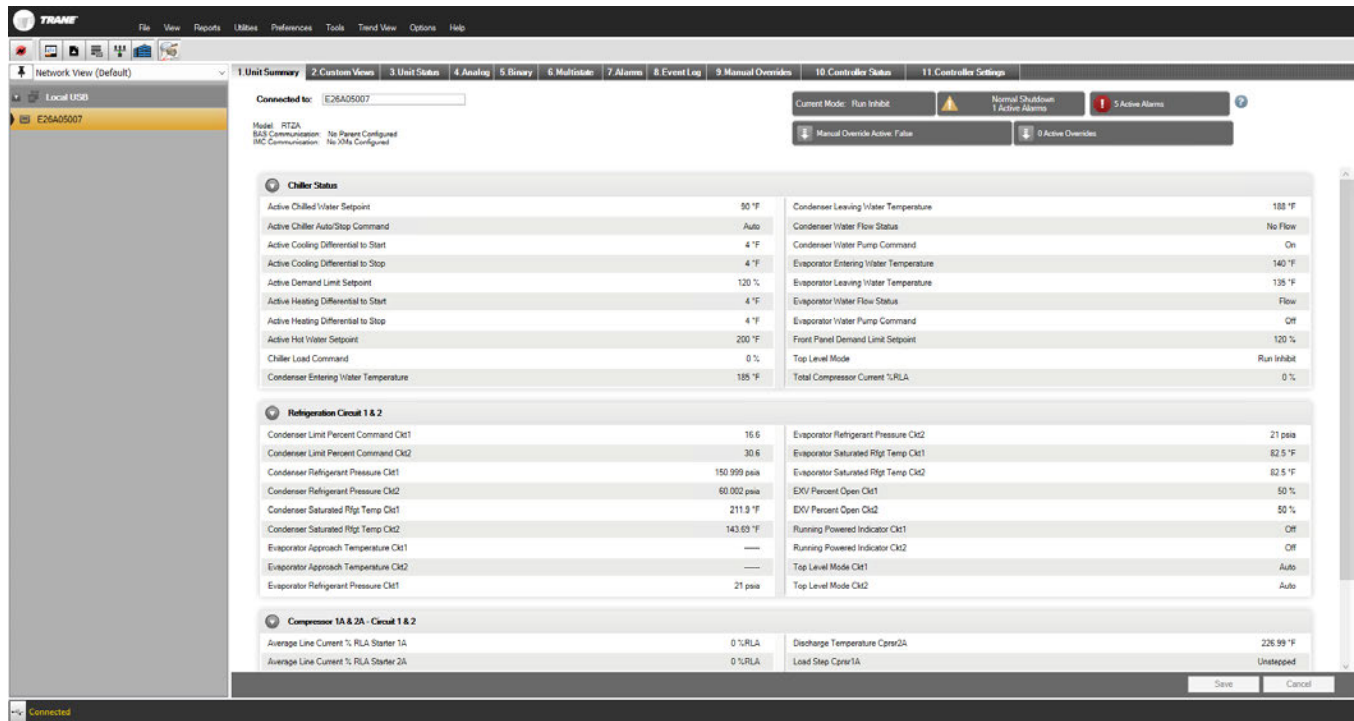

The screenshot displays the Tracer TU software interface for a chiller unit. The top navigation bar includes tabs for Unit Summary, Custom Views, Unit Status, Analog, Binary, Multistate, Alarms, Event Log, Manual Overrides, Controller Status, and Controller Settings. The main content area is divided into several sections:

- Unit Information:** Shows the unit is connected to E26A05007. Status indicators show Current Mode: Run Inhibit, Normal Shutdown: 1 Active Alarm, 5 Active Alarms, Manual Override Active: False, and 0 Active Overrides.
- Chiller Status:** A table of operational parameters.
 

Active Chilled Water Setpoint	50 °F	Condenser Leaving Water Temperature	188 °F
Active Chiller Auto/Stop Command	Auto	Condenser Water Flow Status	No Flow
Active Cooling Differential to Start	4 °F	Condenser Water Pump Command	On
Active Cooling Differential to Stop	4 °F	Evaporator Entering Water Temperature	140 °F
Active Demand Limit Setpoint	120 %	Evaporator Leaving Water Temperature	135 °F
Active Heating Differential to Start	4 °F	Evaporator Water Flow Status	Flow
Active Heating Differential to Stop	4 °F	Evaporator Water Pump Command	Off
Active Hot Water Setpoint	200 °F	Front Panel Demand Limit Setpoint	120 %
Chiller Load Command	0 %	Top Level Mode	Run Inhibit
Condenser Entering Water Temperature	185 °F	Total Compressor Current %RLA	0 %
- Refrigeration Circuit 1 & 2:** A table of refrigeration parameters.
 

Condenser Limit Percent Command Ckt1	16.6	Evaporator Refrigerant Pressure Ckt2	21 psia
Condenser Limit Percent Command Ckt2	30.6	Evaporator Saturated Rfgr Temp Ckt1	82.5 °F
Condenser Refrigerant Pressure Ckt1	150.999 psia	Evaporator Saturated Rfgr Temp Ckt2	82.5 °F
Condenser Refrigerant Pressure Ckt2	60.002 psia	EDV Percent Open Ckt1	50 %
Condenser Saturated Rfgr Temp Ckt1	211.9 °F	EDV Percent Open Ckt2	50 %
Condenser Saturated Rfgr Temp Ckt2	143.63 °F	Running Powered Indicator Ckt1	Off
Evaporator Approach Temperature Ckt1	—	Running Powered Indicator Ckt2	Off
Evaporator Approach Temperature Ckt2	—	Top Level Mode Ckt1	Auto
Evaporator Refrigerant Pressure Ckt1	21 psia	Top Level Mode Ckt2	Auto
- Compressor 1A & 2A - Circuit 1 & 2:** A table of compressor parameters.
 

Average Line Current % RLA Starter 1A	0 %RLA	Discharge Temperature Cprsr2A	236.99 °F
Average Line Current % RLA Starter 2A	0 %RLA	Load Step Cprsr1A	Unstepped

The interface includes a 'Save' button and a 'Cancel' button at the bottom right. A 'Connected' status indicator is visible in the bottom left corner.



## Pre-Start

Upon completion of installation, complete the Installation Completion Check Sheet and Request for Trane Service checklist in .

**Important:** *Start-up must be performed by Trane or an agent of Trane specifically authorized to perform start-up and warranty of Trane products. Contractor shall provide Trane (or an agent of Trane specifically authorized to perform start-up) with notice of the scheduled start-up at least two weeks prior to the scheduled start-up.*



# Start-up and Shutdown

## Temporary Shutdown and Restart

To shut the unit down for a short time:

- Press the STOP key on the AdaptiView™ TD-7. The compressors will continue to operate and an operational pump down cycle may be initiated.
- Symbio™ 800 pump control will turn off both the condenser and chilled water pump (after a minimum one-minute delay) when the STOP key is pressed and automatically restart the pump when the unit starts normally.

To restart the unit after a temporary shutdown, enable the chilled-water pump and press the AUTO key. The unit will start normally, provided the following conditions exist:

- The Symbio 800 receives a call for heating and the differential-to-start is above the setpoint.
- All system operating interlocks and safety circuits are satisfied.

## Extended Unit Shutdown

1. Perform the normal unit stop sequence using the Stop button on the TD-7 Touchscreen.

**Note:** Do not open starter disconnect switch. This must remain closed to provide control power from the control power transformer to the oil sump heater.

2. Verify chilled water and condenser water pumps are cycled off. If needed, open disconnect switches to the pumps.
3. Drain condenser piping and cooling tower, if needed.
4. Remove the drain and vent plugs from the condenser headers to drain the condenser.
5. Verify that the crank case heater is working.
6. Once the unit is secured, perform the maintenance identified in the following sections.

## Seasonal Unit Start-Up Procedure

1. Close all valves and re-install the drain plugs in the evaporator and condenser heads.
2. Service the auxiliary equipment according to the start-up/maintenance instructions provided by the respective equipment manufacturers.
3. Vent and fill the cooling tower, if used, as well as the condenser and piping. At this point, all air must be removed from the system (including each pass). Close the vents in the evaporator chilled water circuits.
4. Open all valves in the evaporator chilled water circuits.
5. If the evaporator was previously drained, vent and fill the evaporator and chilled water circuit. When all air is removed from the system (including each pass), install the vent plugs in the evaporator waterboxes.

### **NOTICE**

#### **Equipment Damage!**

Failure to follow instructions could result in equipment damage.

Ensure that the compressor and oil sump heaters have been operating properly for a minimum of 24 hours before starting.

6. Check the adjustment and operation of each safety and operating control.
7. Close all disconnect switches.
8. Refer to the sequence for daily unit start-up for the remainder of the seasonal start-up.

# Sequence of Operation

## Power-up to Starting

The following diagram shows the timing from a power-up event to energizing the first compressor. The shortest allowable time would be under the following conditions:

- No motor restart inhibit
- Condenser water flowing
- Evaporator water flowing
- Power up start delay set to 0 minutes
- Water pump pre-run time set to 0 minutes
- No condenser head pressure control (stroke time delays)
- Need to heat (differential to start) already exists

The above conditions would allow for a minimum power up to starting the first compressor time of about 95 seconds.

Figure 42. Power-up to start

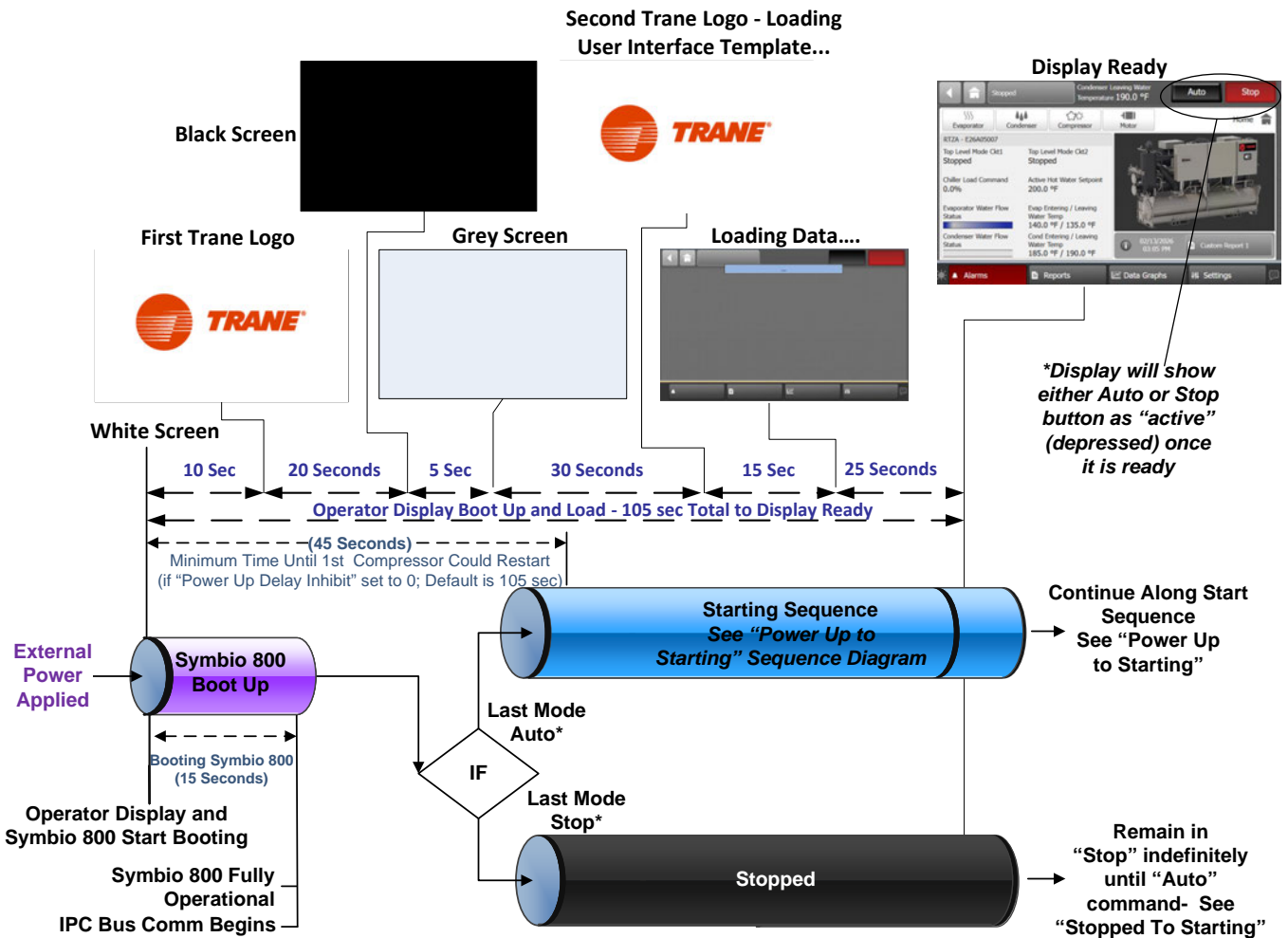

## Stopped to Starting

The following diagram shows the timing from a stopped mode to energizing the first compressor. The shortest allowable time would be under the following conditions:

- No motor restart inhibit time
- Condenser water flowing
- Evaporator water flowing
- Power up start delay timer has expired
- Water pump pre-run time set to 0 minutes
- No condenser head pressure control (stroke time delays)
- Need to heat (differential to start) already exists

The above conditions would allow a compressor to start in about 60 seconds.

Figure 43. Stopped to starting

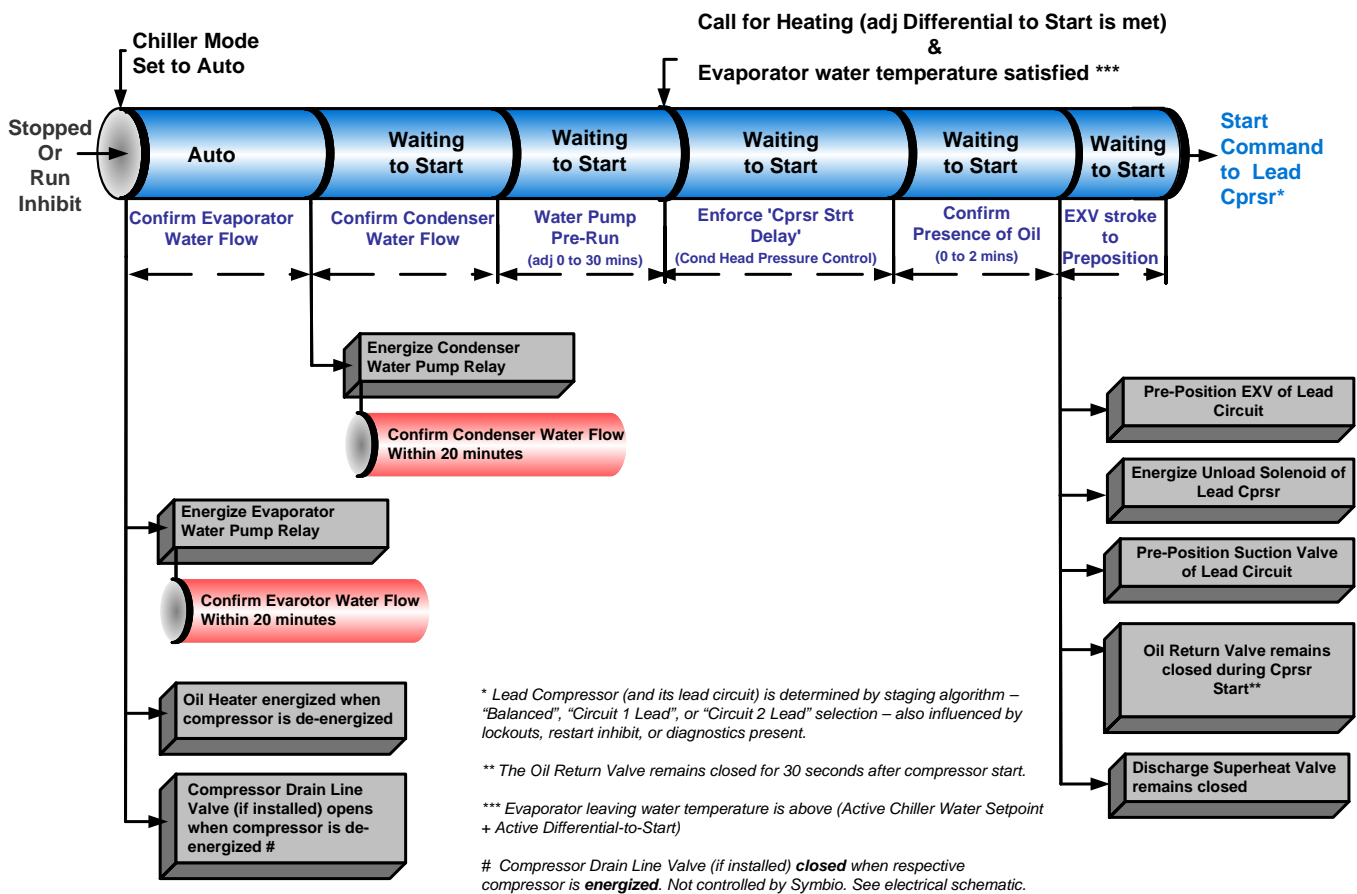

## Normal Shutdown to Stopped

The following diagram shows the transition from running through a normal (friendly) shutdown. The dashed lines at the top display the final mode if stop is selected used various inputs.

Figure 44. Normal shutdown to stopped

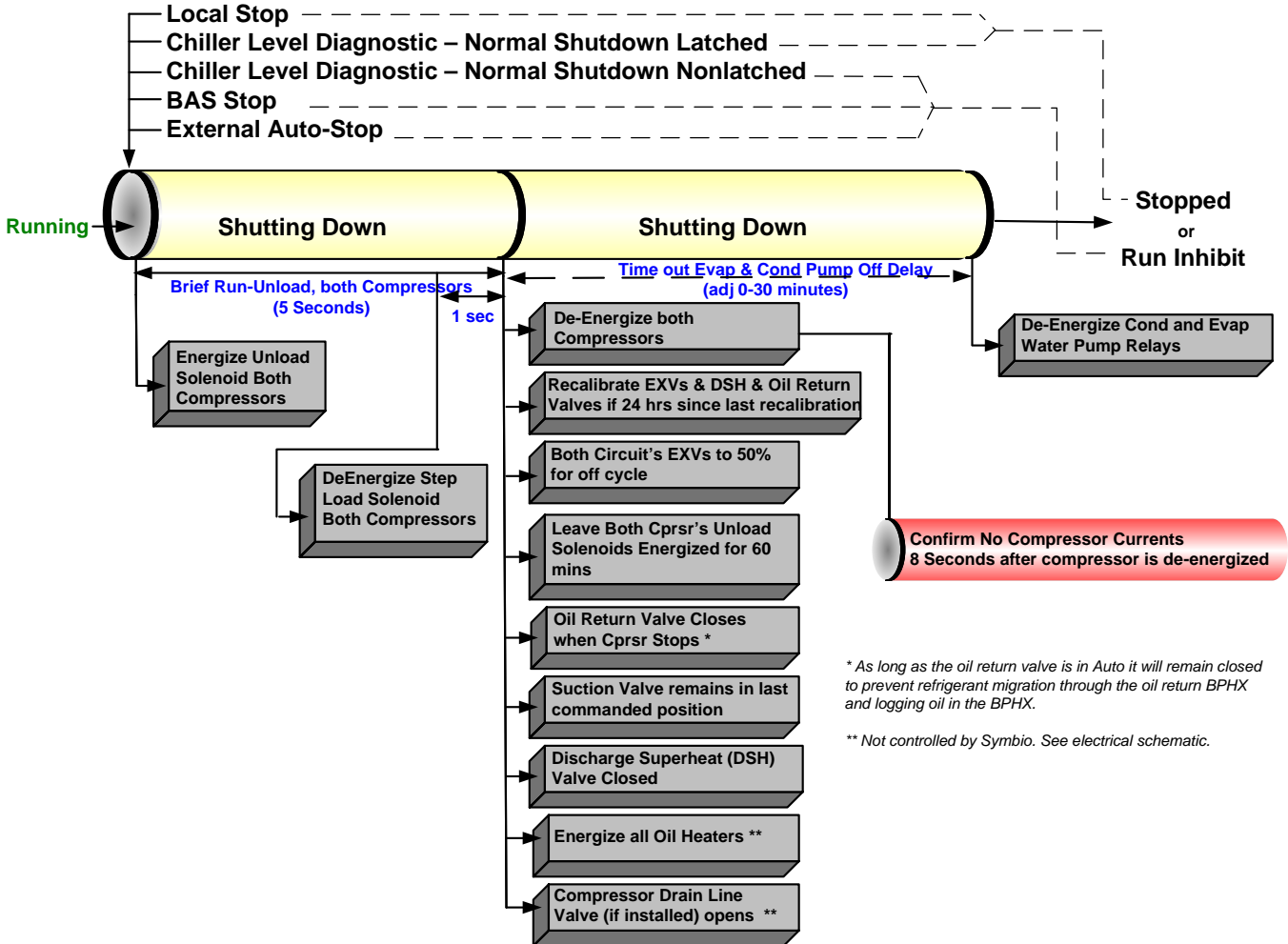

## RTZA-Specific Electrical Devices

### Suction Valve

The valve used for this function has been historically referred to in RTWD as an isolation valve. The isolation valve served to isolate the evaporator from the compressor suction for service. For the RTZA application, the valve is referred to as a suction valve. The suction valve is used to generate lower suction pressure to establish differential pressure across the compressor during operation. One goal of suction valve control is to develop and maintain discharge superheat. This is done by creating pressure drop between the evaporator and the compressor suction by throttling the isolation valve. This develops suction superheat, which translates to higher discharge superheat. This valve is necessary because discharge superheat is more difficult to achieve with this product due to the properties of the refrigerant used.

The suction valve is operated with a linear actuator. A stepper motor is used to extend and retract the extension tube attached to a butterfly valve. The valve actuator is connected to the Symbio™ 800 machine bus. When the actuator is retracted, the valve is closed. During unit power-up, this actuator is calibrated to verify no loss of motor steps. The calibration is additionally performed after 12 hours have elapsed and the respective circuit was stopped and about to restart.

The suction valve operation is normally automatic; however, the valve operation may be overridden manually, if necessary. The suction valve can also serve as an isolation valve. To isolate the evaporator from the compressor suction, use the suction valve override for the respective circuit from the operator display (see below).

**Table 23. Suction valve override settings**

Data Item	Status or Setting	Allowed Values, Setting Default	TD7	TU
Suction Valve Override CktX	Setting	Auto/Manual, Auto	x	x
Manual Suction Valve Command CktX	Setting	0-100%, Auto	x	x
Suction Valve Percent Cmd CktX	Status	%		
Suction Valve Percent Open CktX	Status	%	x	x
Suction Valve Steps Cmd CktX	Status	Steps		x
Suction Valve Position CktX	Status	Steps		x
Suction Valve Max Steps CktX	Setting	1-53960 steps, 51633		x

## Oil Return Valve

The addition of the suction valve between the evaporator and compressor suction line has facilitated the need for a throttling valve in the oil line exiting the evaporator and returning to the suction of the compressor. The purpose of this valve and control is to confirm consistent oil flow for varying system conditions. The type of valve used is similar to an expansion valve (EXV). The valve actuator is connected to the Symbio 800 machine bus.

The oil return valve operation is normally automatic; however, the valve may also be overridden manually if necessary from the from the operator display for the respective circuit (see below).

**Table 24. Oil return valve override settings**

Data Item	Status or Setting	Allowed Values, Setting Default	Volatile or Non-Volatile	TD7	TU
Oil Return Valve Override CktX	Setting	Auto/Manual, Auto	Volatile	x	x
Manual Oil Return Valve Command CktX	Setting	0-100%, Auto	Volatile	x	x
Oil Return Valve Percent Cmd CktX	Status	%	Volatile		x
Oil Return Valve Percent Open CktX	Status	%	Volatile	x	x
Oil Return Valve Position CktX	Status	Steps	Volatile		x
Oil Return Valve Steps Cmd CktX	Status	Steps	Volatile		x

## Differential Pressure Correction

The oil return valve is controlled based on the differential pressure measured by the evaporator shell refrigerant pressure and the compressor suction refrigerant Pressure. The control is sensitive to the inaccurate differential pressure. This zero-offset correction was added to negate the effect of part tolerance or drift by allowing the controller to zero out small values of differential pressure measurement. When possible, the unit controller automatically performs the correction once per week after the chiller has stopped for at least one hour.

For manual correction, the user must verify that the system equilibrium condition prior to performing this correction. The correction process can be initiated by selecting the "Initiate Evap and Cprsr Suction Diff Press Zero Adjustment CktX". The initiate command is a one-shot command.

The zero-offset correction is then used in the oil return valve control algorithm.



## Start-up and Shutdown

**Table 25. Differential pressure settings**

Data Item	Status or Setting	Allowed Values, Setting Default	Volatile or Non-Volatile	TD7	TU	BAS
Initiate Evap and Cprsr Suction Diff Press Zero Adjustment CktX	Setting	Yes/No (No)	Volatile	-	x	-
Evap and Cprsr Suction Diff Press Zero Offset CktX	Setting	-1.45 to 5.80 0.00 PSID	Non-Volatile	-	x	-
Evap and Cprsr Suction Diff Pressure CktX	Status	PSID	Volatile	-	x	-

## Discharge Superheat Valve

The discharge superheat valve returns discharge refrigerant gas from the oil separator to the compressor suction. This return flow increases discharge superheat and modulates to maintain the target superheat needed to keep the proper refrigerant concentration in the oil separator sump. This allows the oil to reach the viscosity required for compressor bearing reliability and longevity and helps prevent potential oil loss in the separator. The type of valve used is similar to an expansion valve (EXV). The valve actuator is connected to the Symbio 800 machine bus.

The discharge superheat valve operation is normally automatic; however, the valve may also be overridden manually, if necessary, from the operator display for the respective circuit (see below).

**Table 26. Discharge superheat valve override settings**

Data Item	Status or Setting	Allowed Values, Setting Default	Volatile or Non-Volatile	TD7	TU	BAS
Low Disch Superheat Trip Setpt CprsrXY	Setting	8.5F	Non-Volatile	x	x	-
Calc Discharge Superheat Ctrl Target CktX	Status	(0-36)Delta Temp (F)	Volatile	-	x	-
Discharge Superheat Control Prop Gain	Setting	(0 – 100), 10	Non-Volatile	x Svc	X Level 4	-
Discharge Superheat Control Integral Time	Setting	(1-2000), 100 Seconds	Non-Volatile	x Svc	x Level 4	-
Discharge Superheat Valve Override CktX	Setting	Auto/Manual, Auto	Volatile	x	x	-
Manual Discharge Superheat Valve Cmd CktX	Setting	0-100%, Auto	Volatile	x	x	-
Discharge Superheat Valve Pct Cmd CktX	Status	%	Volatile	-	x	-
Discharge Superheat Valve Pct Open CktX	Status	%	Volatile	x	x	-
Discharge Superheat Valve Pos Steps CktX	Status	Steps	Volatile	-	x	-
Discharge Superheat Valve Steps Cmd CktX	Status	Steps	Volatile	-	x	-

## Evaporator Shell Pressure Transducers

Evaporator Shell pressure sensors were added. These sensors were necessary as a result of the suction valve between the evaporator shell and the compressor suction. These sensors are used for diagnostics associated with the protection of the evaporator (for example, Low Evaporator Refrigerant Temperature).

## High Condenser Water Temperature Cutout

A thermal switch is mounted on the condenser water box flange. The condenser leaving water temperature is continuously monitored to verify that it does not exceed a threshold of 225°F. If exceeded, the switch will mechanically trip and shut down the unit. A High Condenser Water Temperature Cutout diagnostic will display on the operator display. The thermal switch must be manually reset to allow the unit to restart.

To restart the unit:

1. Manually reset the thermal switch by pressing the plunger located at the top of the housing.

**Note:** If step 1 is not performed, the High Condenser Water Temperature Cutout diagnostic will continue to generate as an Active Alarm.

2. Reset Alarms on the operator display.

Figure 45. Reset plunger

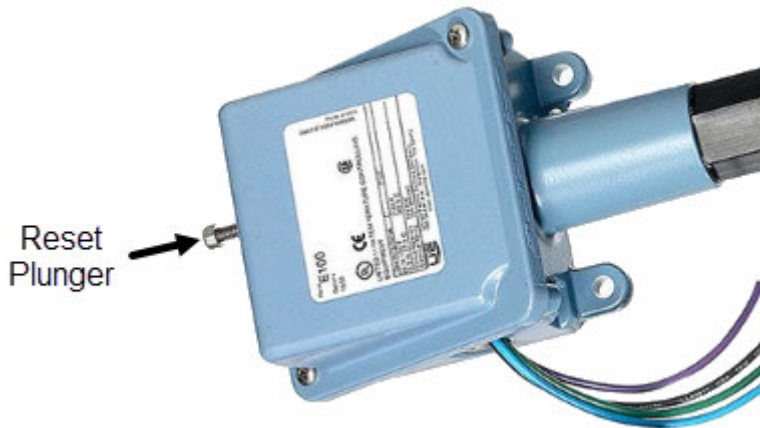

### Water Flow Measurement Pressure Transducers

Pressure transducers provide water flow measurement through the evaporator and condenser. Differential water pressure is determined using two individual pressure sensors and flow is calculated. Water flow rate is used in part to determine the Calculated Heat Pump Capacity, and also utilized to prove flow in place of a flow switch device. The flow measurement feature is the standard offering for the RTZA Heat Pump.

### Flow Calibration

Periodic calibration of the differential pressure transducers may be necessary to confirm accurate flow measurement. The following requirements and procedure is required to perform the calibration. The evaporator calibration is described below; however, the condenser calibration is identical.

### Requirements

To perform the calibration, the following items are required:

- Access to Tracer TU.
  - The Evaporator/Condenser Pump Overrides and the Evaporator/Condenser Differential Pressures are displayed on the operator display (TD7). For all other settings and statuses, the Tracer TU is required.
- An independent flow measurement.
- Ability to create flow. There are two flow rates (Low Flow & High Flow) required during the calibration.

### No Flow

1. Confirm there is no flow. It is important that a service technician verifies that there is no flow before executing this command.
2. Under Field Startup | Level 4, **Initiate Evap Water Flow Zero Adjustment**, select **Yes**.

Figure 46. Initiate evaporator water flow zero adjustment display

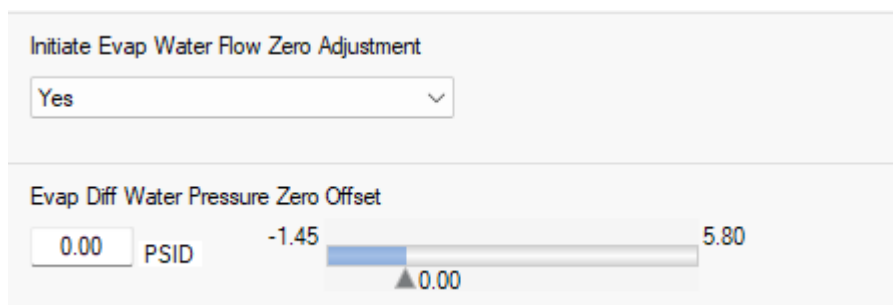

3. Click **Save**.
4. Navigate away from the **Setpoint** tab and come back (this is for the data to refresh on the Setpoint tab).

## Start-up and Shutdown

- The value under **Initiate Evap Water Flow Zero Adjustment** will change to **No** automatically.
- The value under the **Evap Diff Water Pressure Zero Offset** will populate automatically. The controller takes the current filtered differential pressure, add 0.5 KPa to it, and save this value as a bias which is subtracted off of the measured differential pressure.
- If necessary, the value under **Evap Diff Water Pressure Zero Offset** can be modified.

**Note:** Control algorithm expects changes in the differential pressure measurement to initiate the zero adjustment. When testing in a static environment, a slight change to the differential pressure is required for this step to work.)

**Figure 47. Modify evaporator differential water pressure display**

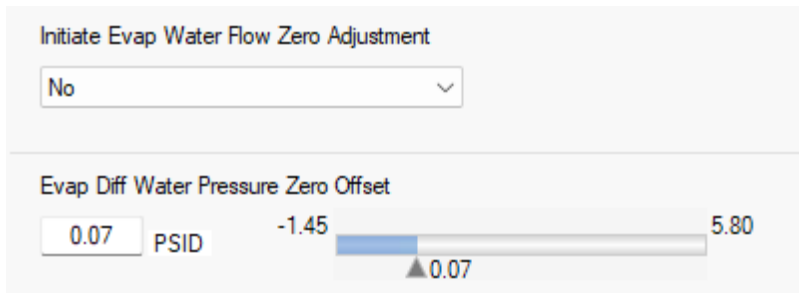

### Low Flow

1. Introduce a low flow rate (for example, 1.2 gpm/ton) using manual override to control pump speed and flow rate. Wait several minutes to confirm steady state operation.
2. In the **Evaporator Water Flow Point 1**, enter the flow measurement measured from the independent flow meter.

**Figure 48. Evaporator water flow point 1 display**

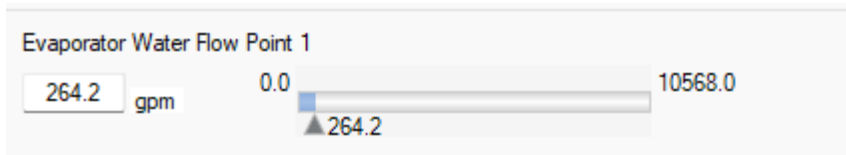

3. In the **Evaporator Pressure Drop Point 1**, enter the differential pressure, which can be found on TD7 or TU under **Evaporator Differential Water Pressure**.

**Figure 49. Evaporator pressure drop point 1 display**

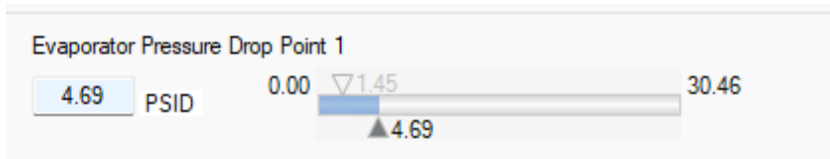

Figure 50. TD7 – evaporator differential water pressure

1. Unit Summary	2. Custom Views	3. Unit Status	4. Analog	5. Binary	6. Multistate	7. Alarms	8. E
<b>Connected to: RTZA - E26A05007</b>							
Model: RTZA							
Cooling Modulation Command		0.0					
Demand Limit Softloading Target		0 %					
Emergency Stop		Auto					
Evaporator Entering Water Temperature		140 °F					
Evaporator Leaving Water Temperature		135 °F					
Evaporator Entering Water Pressure		140.005 psia					
Evaporator Leaving Water Pressure		135 psia					
Evaporator Differential Water Pressure		4.69 PSID					
Calculated Chiller Capacity		91 tons					

Figure 51. TU – evaporator differential water pressure

The screenshot shows a control interface for a unit. At the top, it says "Stopped" and "Condenser Leaving Water Temperature 190.0 °F". There are "Auto" and "Stop" buttons. Below this are icons for Evaporator, Condenser, Compressor, and Motor. The "Evaporator" icon is selected. The interface displays several data points:

- EXV Percent Open Ckt1: 50.0%
- Oil Return Valve Percent Open Ckt1: 0.0%
- Evaporator Refrigerant Liquid Level Ckt1: 0.00 in
- Evaporator Shell Sat Rfgt Temp Ckt1: 89.5 °F
- Evaporator Shell Rfgt Pressure Ckt1: 24.0 PSIA
- Approximate Evaporator Water Flow: 446.1 gpm
- Evaporator Differential Water Pressure: 4.93 PSID** (highlighted with a blue box)
- Calculated Chiller Capacity: 93.3 tons

At the bottom, there are buttons for "Circuit 1" and "Circuit 2", and a "Page 2 of 3" indicator with navigation arrows. The bottom navigation bar includes "Alarms", "Reports", "Data Graphs", and "Settings".

### High Flow

1. Introduce a high flow rate (i.e. 2.4 gpm/ton). Wait several minutes to confirm steady state operation.
2. In the **Evaporator Water Flow Point 2**, enter the flow measurement recorded from the independent flow meter.

## Start-up and Shutdown

Figure 52. Evaporator water flow point 2 display

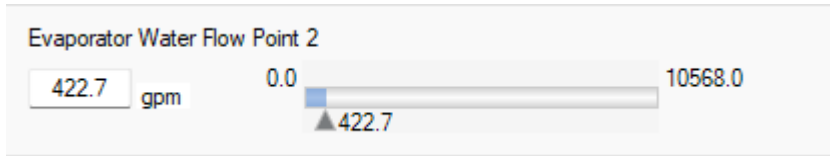

- In the **Evaporator Pressure Drop Point 2**, enter the differential pressure, which can be found on TD7 or TU under **Evaporator Differential Water Pressure**.

Figure 53. Evaporator pressure drop point 2 display

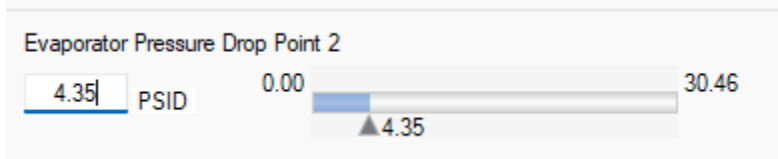

### Fluid Property

Enter the Fluid Specific Gravity and Heat. The default shown is adequate for water. For other fluids, consult the fluid property data sheet or seek engineering assistance.

Figure 54. Evaporator fluid specific gravity and heat

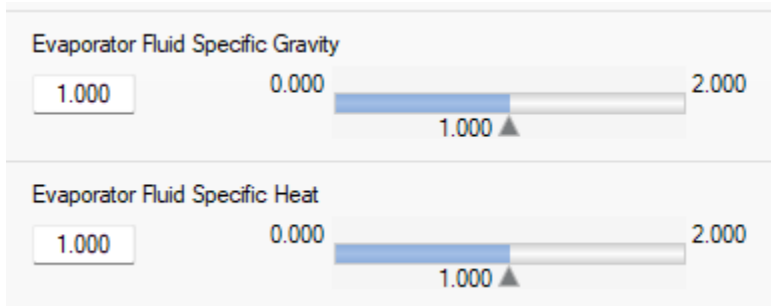

Repeats the steps above using the corresponding settings for condenser water flow calibration.

Figure 55. Settings for condenser water flow calibration



### Water Temperature Coordination

To provide heating, at the elevated temperatures required for a RTZA unit, it is necessary that the water temperature entering the evaporator be much higher than a conventional chiller. A typical entering evaporator temperature is about 90°F. The RTZA is a heat pump and will “lift” the water temperature from evaporator to the condenser. To confirm proper operation, it is necessary for evaporator entering water temperature and water flow rate to be above a specific threshold. Various methods are possible to provide heated evaporator entering water. For example, the water may be heated from some form of waste heat or may be heated by another chiller’s condenser loop. In either case, the RTZA unit has no control over the conditions entering the evaporator and therefore cannot control the amount of heat supplied to the system.

To address that lack of control of the evaporator conditions, the Water Temperature Coordination feature provides a comprehensive method of control that considers both the conditions of the condenser and the evaporator. During unit starting and operation, compressor modulation and staging are utilized to balance the heat transfer to keep the unit “on-line” to produce as much capacity as possible.

The RTZA is a heating only unit and has a Hot Water Setpoint. It also has a Heating Differential to Start and Heating Differential to Stop. The addition of *Water Temperature Coordination* adds a Chilled Water Setpoint and Cooling Differential to Start and Cooling Differential to Stop. The Chilled Water Setpoint provides a target for modulation limits. The Cooling Differential to Stop provides a staging target that, if necessary, provides a controlled shutdown of the last running compressor to prevent the evaporator from dropping below the Low Evaporator Refrigerant Pressure diagnostic. The Cooling Differential to Start Provides a target below which the unit will not start. If this occurs a mode will indicate that operation is inhibited.

The following diagram illustrates the evaporator and condenser cycles for a normal operating RTZA unit (No Limits). The diagram shows evaporator conditions that meet the requirements to achieve the Hot Water Setpoint. Notice the evaporator cycle is well above the Chiller Water Setpoint (CW Target). In this case the unit can achieve the Hot Water Setpoint (HW Target) and is operating with no limits. Notice also that the evaporator cycle is operating in a region that is well above the Chilled Water Setpoint (CH Target) and well above the Cooling Differential to Start.

## Start-up and Shutdown

Figure 56. Evaporator and condenser cycles for normal operation

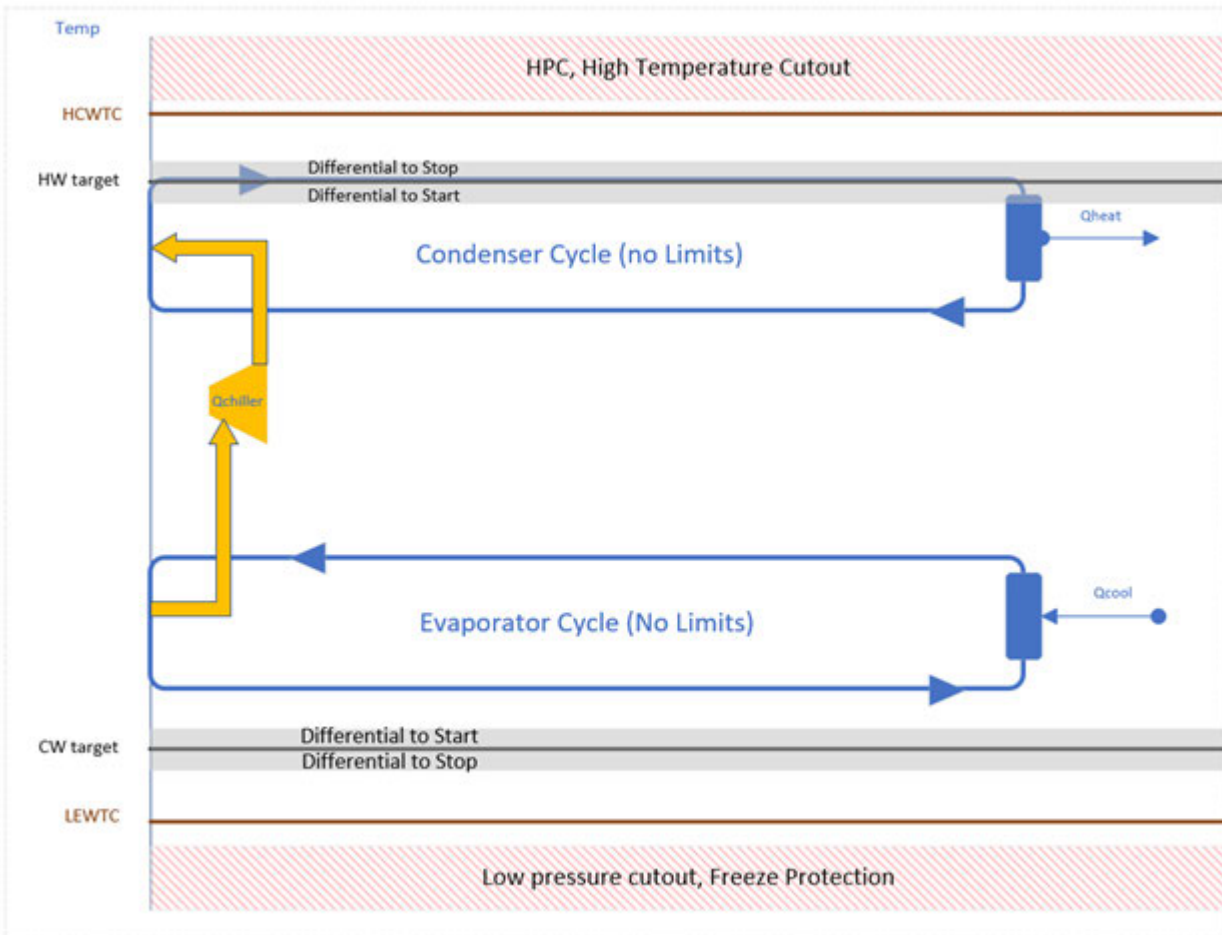

The next diagram illustrates the evaporator and condenser cycles for a RTZA unit with insufficient cooling load (Limits Applied). The diagram shows that with insufficient evaporator cooling load, the evaporator cycle is operating at a lower temperature. In this condition, modulation limits and, if necessary, un-staging has been applied to keep the evaporator above the low-pressure cutout. In this case the unit cannot achieve the Hot Water Setpoint (HW Target) and will operate at a reduced condenser leaving temperature. Notice that the evaporator cycle is operating in a region near Chilled Water Setpoint (CW Target). If the evaporator temperature continues to drop with one compressor, operating at minimum load, the evaporator temperature will drop below the Cooling Differential to Stop, and the unit will shut down.

Figure 57. Evaporator and condenser operating cycles for insufficient cooling load

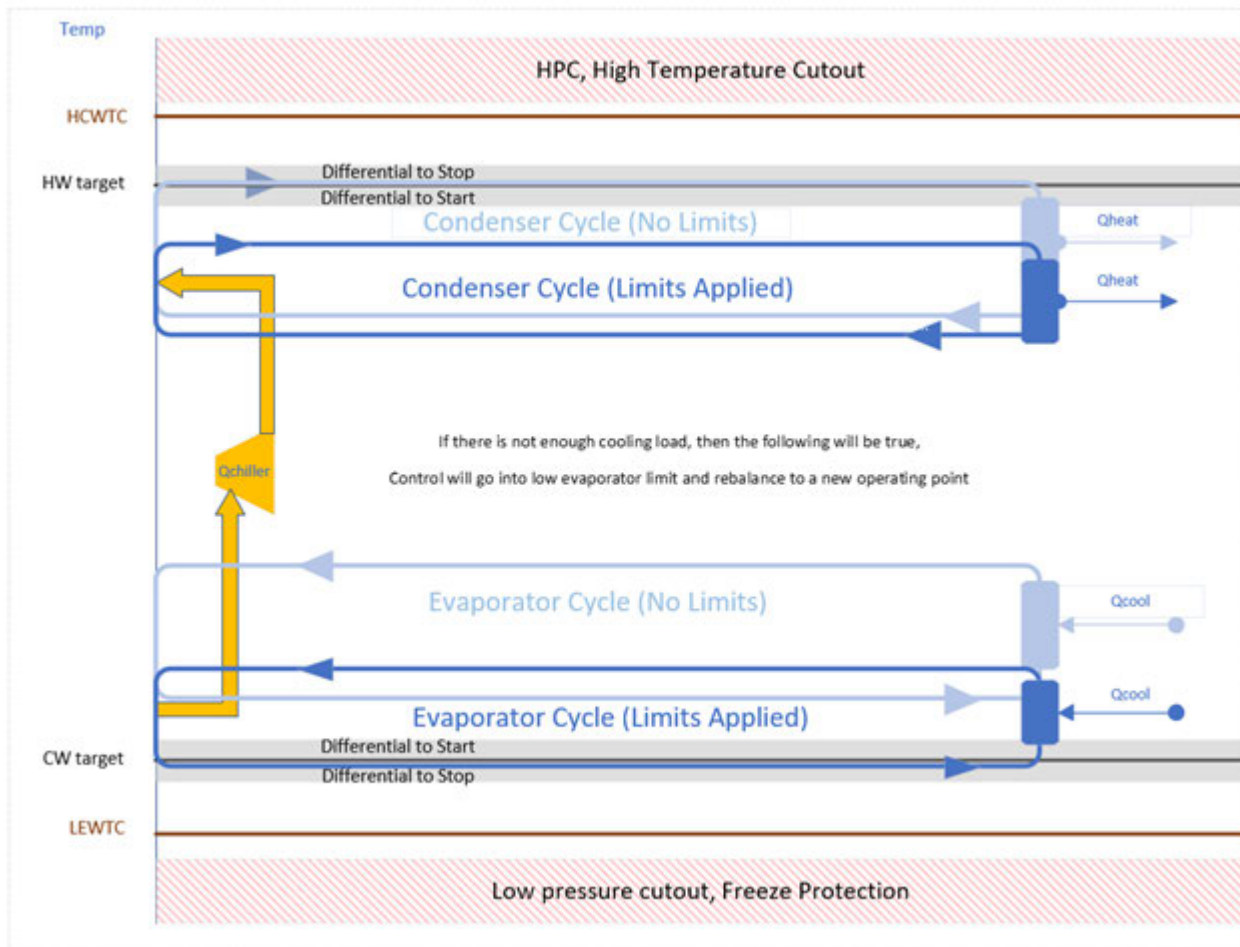

**Modes**

The following modes will be displayed to inform the operator that Water Temperature Coordination is in effect.

- Start Inhibited by Low Evap Water Temp  
Occurs when the Active Cooling Differential to Start is unsatisfied.
- Low Evaporator Leaving Water Temperature Limit  
Occurs when running and the evaporator cooling load is unsatisfactory
- Waiting for a Need to Heat  
Occurs when the Active Heating Differential to Start is unsatisfied.



# Maintenance

## Overview and Maintenance Checks

This section describes preventative maintenance procedures and intervals. Use a periodic maintenance program to confirm optimal performance and efficiency of the Series R® units.

An important aspect of the chiller maintenance program is the regular completion of operator logs. When filled out properly, the completed logs can be reviewed to identify any developing trends in the chiller's operating conditions.

### ⚠ WARNING

#### Hazardous Voltage!

Failure to disconnect power before servicing could result in death or serious injury.

Disconnect all electric power, including remote disconnects before servicing. Follow proper lockout/tagout procedures to ensure the power can not be inadvertently energized. Verify that no power is present with a voltmeter.

### ⚠ WARNING

#### Live Electrical Components!

Failure to follow all electrical safety precautions when exposed to live electrical components could result in death or serious injury.

When it is necessary to work with live electrical components, have a qualified licensed electrician or other individual who has been properly trained in handling live electrical components perform these tasks.

## Weekly Maintenance and Checks

After the unit has operated for approximately 30 minutes and the system has stabilized, check the operating conditions and complete the procedures below:

- Log the chiller.
- Check evaporator and condenser pressures with gauges and compare to the reading on the unit chiller. Pressure readings should fall within the specified ranges listed in "Refrigerant and Oil Charge Management," p. 92. If chiller measurements vary significantly from values listed, problems may exist with refrigerant and oil charge levels. Contact local Trane service.

**Note:** Optimal condenser pressure is dependent on condenser water temperature, and should equal the saturation pressure of the refrigerant at a temperature 2 to 5°F above that of leaving condenser water at full load.

## Monthly Maintenance and Checks

- Review the operator logs.
- Clean all water strainers in both the chilled and condensing water piping systems.
- Measure and log the subcooling and superheat.

## Annual Maintenance

Shut down the chiller once each year to check the following:

- Perform all weekly and monthly maintenance procedures.
- Have a qualified laboratory perform an oil analysis to determine system moisture content and acid level (see "Refrigerant and Oil Charge Management," p. 92 for requirements and additional time-based oil sampling).
- Contact Trane service organization to leak check the chiller, to inspect safety controls, and inspect electrical components for deficiencies.
- Inspect all piping components for leakage and/or damage. Clean out any inline strainers.
- Clean and repaint any areas that show signs of corrosion.
- Inspect vent piping of all relief valves for presence of refrigerant to detect improperly sealed relief valves. Contact Trane service if unusual conditions are observed.
- Inspect the condenser tubes for fouling. Clean if necessary.
- Confirm that the crank case heater, oil separator heater, and compressor suction belly band heater are working.

- Replace the filter drier core.
- Perform the flow proving calibration every 6 months (see “RTZA-Specific Electrical Devices,” p. 70). If the heat pump is operating close to the minimum/low flow limit, then more regular calibration should be performed.
- RTZA oil should be changed initially at 750 hours; after that the oil and compressor oil filter should be changed every 45,000 hours.

## Refrigerant and Oil Lab Analysis Schedule

Samples of refrigerant and oil should be taken from the unit prior to start-up. This establishes a baseline for comparing subsequent oil samples. “Refrigerant and Oil Lab Analysis Schedule,” p. 81 provides the recommended inspection intervals. Draw oil from the oil separator and collect in a 125 mL Thermo Scientific™ Nalgene™ narrow-mouth HDPE lab-quality bottle with cap, or an equivalent container. See the below table for acceptable oil sample limits.

**Table 27. Recommended lab analysis interval**

Months after startup	Months since last sample
0	0
2	3
9	6
18	9
30	12

Use the below tables as reference when reviewing oil and refrigerant sample reports.

**Table 28. Acceptable refrigerant guidelines**

	Non-Condensable (% Volume)	Other Organic Impurities (% Weight)	Moisture (ppm)	Acidity (ppm as HCl)	High Boiling Residue (% Volume)	Blend Analysis (% Weight)
Estimated Accuracy	± 0.1%	± 0.02%	± 15%	± 15%	±0.001%	Operating Units: ±0.50%
Meets AHRI 700-2017 Specifications	<0.01% - 1.50%	≤0.01% - 0.50%	≤20	≤1.0	<0.01% - 0.01%	See Blend Analysis Guidelines

Calumet Sontex 500-LE mineral oil is the approved oil for RTZA units.

**Table 29. Oil reference specifications**

	Total Acid Number	Moisture	Viscosity
Guidelines	New Mineral Oil: 0.01 maximum Used Mineral Oil: 0.05 maximum	New Mineral Oil < 30 ppm Used Mineral Oil < 50 ppm	Minimum 90 cSt Maximum 110 cSt

**Note:** Use an oil transfer pump to change the oil regardless of heat pump pressure.

## Scheduling Other Maintenance

- Use a nondestructive tube test to inspect the condenser and evaporator tubes at 3-year intervals.  
**Note:** It may be desirable to perform tube tests on these components at more frequent intervals, depending upon chiller application. This is especially true of critical process equipment.
- Depending on chiller duty, contact a qualified service organization to determine when to conduct a complete examination of the unit to determine the condition of the compressor and internal components.



# Heat Exchanger Maintenance

## Condenser Cleaning

### NOTICE

#### Proper Water Treatment Required!

The use of untreated or improperly treated water could result in scaling, erosion, corrosion, algae or slime. Use the services of a qualified water treatment specialist to determine what water treatment, if any, is required. Trane assumes no responsibility for equipment failures which result from untreated or improperly treated water, or saline or brackish water.

Condenser tube fouling is suspected when the approach temperature (for example, the difference between the refrigerant condensing temperature and the leaving condenser water temperature) is higher than predicted.

Standard water applications will operate with less than a 10°F approach. If the approach exceeds 10°F, cleaning the condenser tubes is recommended.

**Note:** Glycol in the water system may as much as double the standard approach.

If the annual condenser tube inspection indicates that the tubes are fouled, two cleaning methods can be used to rid the tubes of contaminants.

- Mechanical tube cleaning method is used to remove sludge and loose material from smooth-bore condenser tubes. See “Mechanical Cleaning Procedure,” p. 82.
- Chemical cleaning procedures are used to remove scale deposits. See “Chemical Cleaning,” p. 88.

### Mechanical Cleaning Procedure

### ⚠ WARNING

#### Heavy Objects!

Failure to properly lift waterbox could result in death or serious injury.

Each of the individual cables (chains or slings) used to lift the waterbox must be capable of supporting the entire weight of the waterbox. The cables (chains or slings) must be rated for overhead lifting applications with an acceptable working load limit. Refer to the waterbox weights table.

### ⚠ WARNING

#### Straight Vertical Lift Required!

Failure to properly lift waterbox in straight vertical lift could cause the eyebolts to break which could result in death or serious injury from object dropping.

The proper use and ratings for eyebolts can be found in ANSI/ASME standard B18.15. Maximum load rating for eyebolts are based on a straight vertical lift in a gradually increasing manner. Angular lifts will significantly lower maximum loads and should be avoided whenever possible. Loads should always be applied to eyebolts in the plane of the eye, not at some angle to this plane.

Table 30. Condenser waterbox weights

Weight – kg (lb)	Lifting Connection
37.5 (82.7)	Lifting Lug with 15/32-inch diameter hole

Review the mechanical room limitations and determine the safest method for rigging and lifting the waterboxes.

### Return Waterbox Removal

### ⚠ WARNING

#### Hot Surface!

Failure to follow instructions below could result in severe burns.

Surface temperatures may exceed 300°F (150°C). To avoid possible skin burns, stay clear of these surfaces. If possible, allow surfaces to cool before servicing. If servicing is necessary while surface temperatures are still elevated, you MUST put on all Personal Protective Equipment (PPE).

1. Remove all water side pressure from the condenser. A drain and vent port is located on each waterbox as shown in [Figure 36, p. 51](#).
2. Verify unit surface is not hot to the touch.
3. The insulation that covers the waterbox shell extends over the bolt heads. Remove the insulation covering the return waterbox bolts. The whole sheet can be removed, or insulation may be cut and removed directly over each bolt head.
4. Remove the waterbox bolts in the locations shown in [Figure 59, p. 84](#), and replace with the long bolts located in the tube sheet. Hand-tighten the long bolts.
5. Attach a shackle to the lifting eye below, rated according to [Table 30, p. 82](#), and loosely connect the over head lift strap.
6. Remove all the remaining waterbox bolts.

**Figure 58. Waterbox overview**

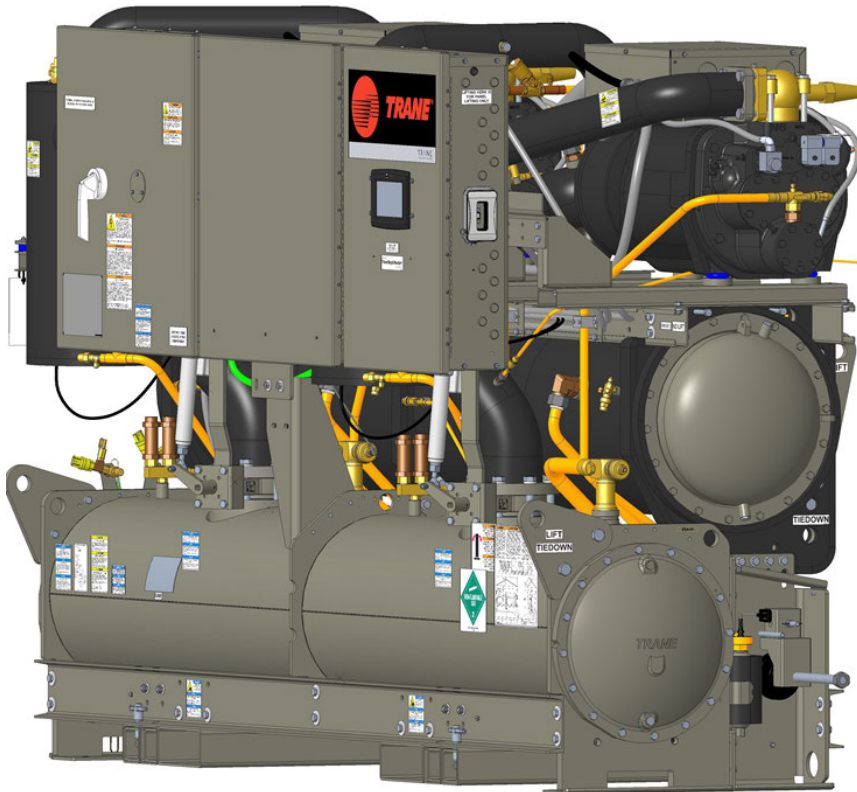

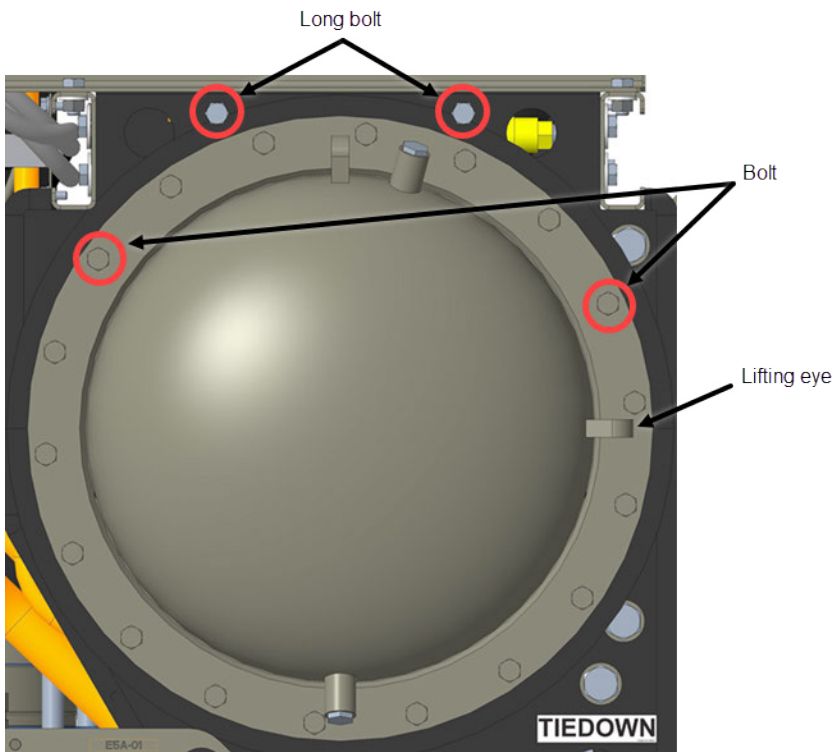
**Figure 59. Remove waterbox bolts**

7. Slide the waterbox out approximately 30 mm on the long bolts.

Figure 60. Side view – waterbox slide-out on long bolts

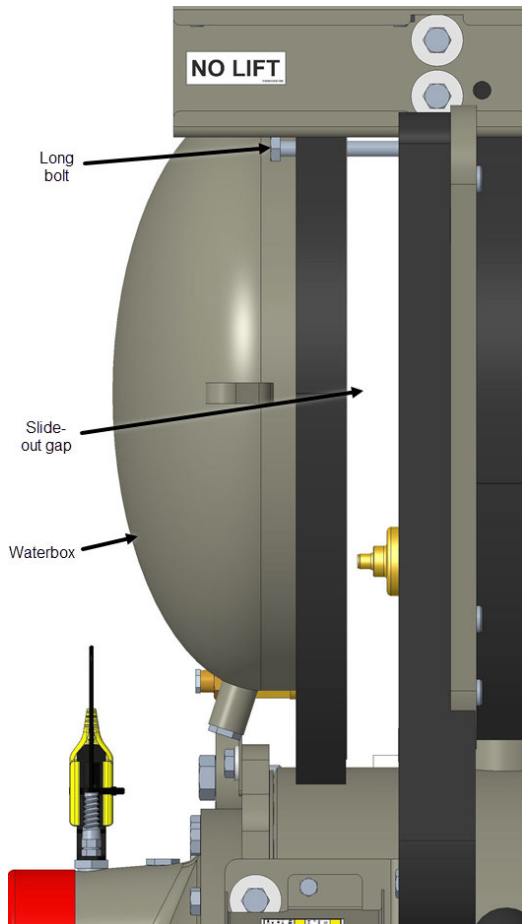

8. Remove the left long bolt while supporting the waterbox, and allow the water box to rotate around the right side long bolt.
9. Apply tension in the lifting strap and remove the right long bolt.
10. Remove the waterbox and store in a safe location, with face protected from damage. Do not keep the waterbox suspended and protect the face seal from damage.

Figure 61. Condenser return waterbox removal (insulation removed for clarity)

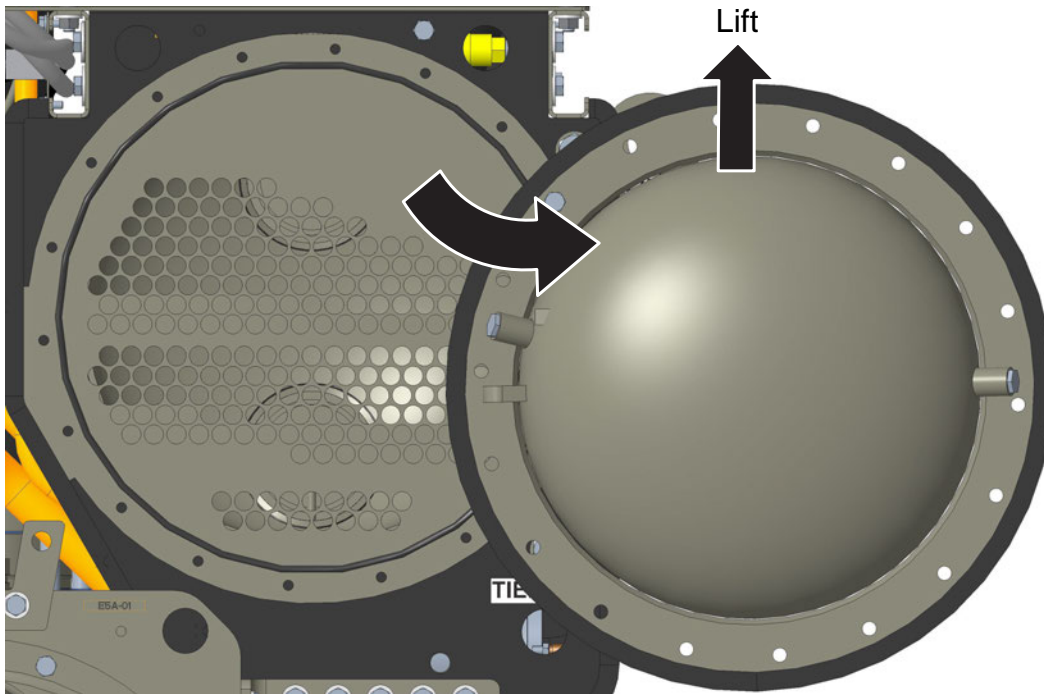

### Condenser Tube Cleaning – Mechanical

1. Using a round nylon or brass bristled brush (attached to a rod) loosen the sludge in each of the condenser water tubes.
2. Thoroughly flush the condenser water tubes with clean water.

**Note:** To clean internally-enhanced tubes, use a bidirectional brush or consult a qualified service.

### Reassembly

When service is completed, reinstall the waterbox and cover following all previous procedures in reverse.

1. Thoroughly clean all joints and use new o-rings and/or gaskets. Contact local Trane parts center for information.
2. Torque waterbox/cover bolts in a star pattern to 65 ft-lbs (88 N·m).

### Evaporator Cleaning

Since the evaporator is typically part of a closed circuit, it does not accumulate appreciable amounts of scale or sludge. However, if cleaning is deemed necessary, two cleaning methods are available.

- Refer to “[Mechanical Cleaning Procedure](#),” p. 82 to remove sludge and loose material from smooth-bore condenser tubes.
- Refer to “[Chemical Cleaning](#),” p. 88 to remove scale deposits.
- See [Table 31](#), p. 87.

### Mechanical Cleaning Procedure

#### **⚠ WARNING**

#### **Heavy Objects!**

Failure to properly lift waterbox could result in death or serious injury.

Each of the individual cables (chains or slings) used to lift the waterbox must be capable of supporting the entire weight of the waterbox. The cables (chains or slings) must be rated for overhead lifting applications with an acceptable working load limit. Refer to the waterbox weights table.

## ⚠ WARNING

### Straight Vertical Lift Required!

Failure to properly lift waterbox in straight vertical lift could cause the eyebolts to break which could result in death or serious injury from object dropping.

The proper use and ratings for eyebolts can be found in ANSI/ASME standard B18.15. Maximum load rating for eyebolts are based on a straight vertical lift in a gradually increasing manner. Angular lifts will significantly lower maximum loads and should be avoided whenever possible. Loads should always be applied to eyebolts in the plane of the eye, not at some angle to this plane.

**Table 31. Evaporator waterbox weights**

Weight – kg (lb)	Lifting Connection
33.6 (74)	Safety hoist ring (RNG01886) or equivalent M12 x 1.75"

Review the mechanical room limitations and determine the safest method for rigging and lifting the waterboxes.

### Return Waterbox Removal

1. Remove all water side pressure from the evaporator. A drain and vent port is located on each waterbox (see [Figure 36, p. 51](#)).
2. For 2-pass units, continue to next step. For 3-pass units, remove the following:
  - a. Temperature gauge wire
  - b. LLID (optional, to prevent storage damage)
  - c. Differential pressure transducer (depending on the customer piping installation)

**Figure 62. Disconnect waterbox assembly**

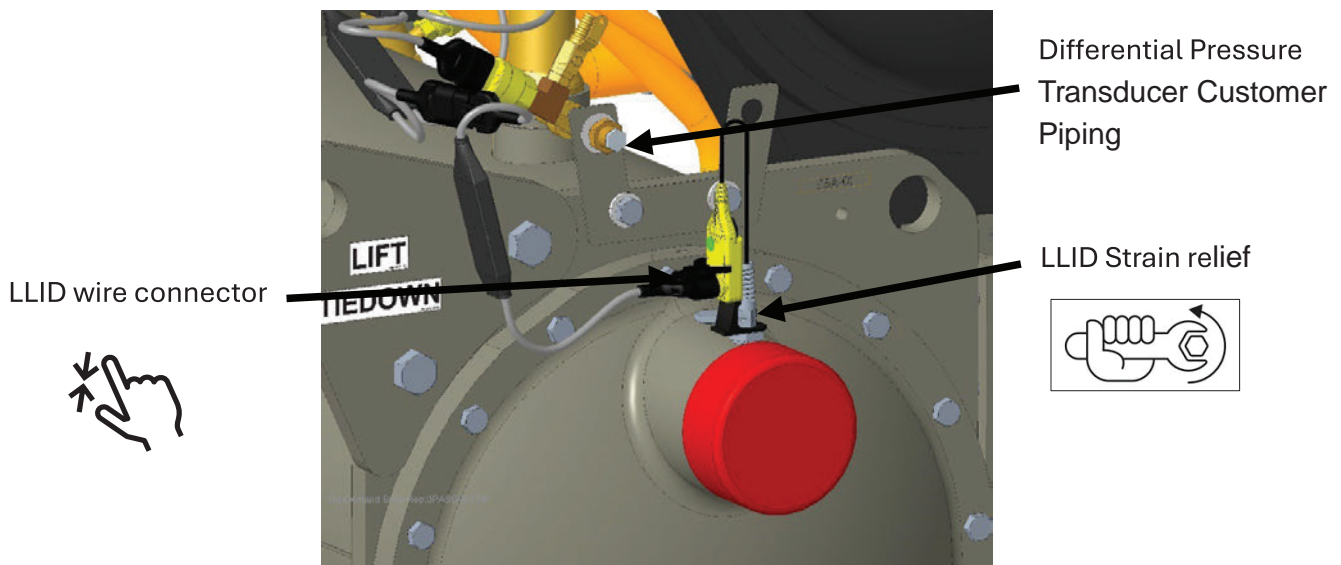

3. Connect the safety hoist ring to the top of the waterbox according to [Table 31, p. 87](#).  
Remove slack in the lifting strap.
4. Remove all the waterbox bolts.

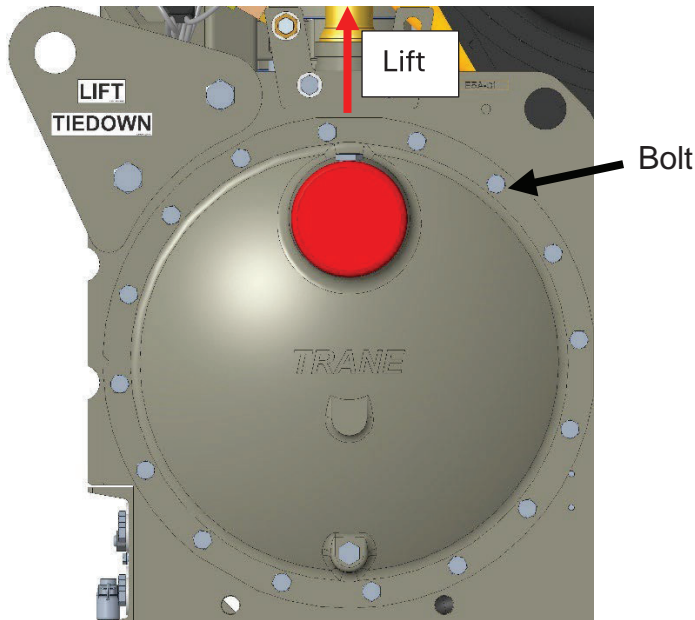
**Figure 63. Evaporator waterbox – side view**

### Evaporator Tube Cleaning – Mechanical

1. Using a round nylon or brass bristled brush (attached to a rod) loosen the sludge in each of the evaporator water tubes.
2. Thoroughly flush the evaporator water tubes with clean water.

**Note:** To clean internally-enhanced tubes, use a bidirectional brush or consult a qualified service.

### Reassembly

When service is completed, reinstall the waterbox and cover following all previous procedures in reverse.

1. Thoroughly clean all joints and use new o-rings and/or gaskets. Contact local Trane parts center for information.
2. Torque waterbox/cover bolts in a star pattern to 65 ft-lbs (88 N·m).

### Chemical Cleaning

Scale deposits are best removed by chemical means. Consult a qualified water treatment specialist (i.e., one that knows the local water supply chemical/mineral content) for a recommended cleaning solution suitable for the job. (A standard condenser water circuit is composed solely of copper, cast iron, and steel.) Improper chemical cleaning can damage tube walls.

All of the materials used in the external circulation system, the quantity of the solution, the duration of the cleaning period, and any required safety precautions should be approved by the company furnishing the materials or performing the cleaning.

**Note:** Chemical tube cleaning should always be followed by mechanical tube cleaning.

# Lubrication System

## Compressor Oil

### NOTICE

#### Equipment Damage!

Failure to follow instructions could result in oil sump heater burnout.

Open the unit main power disconnect switch before removing oil from the compressor.

## Compressor Oil Removal

The oil in the compressor oil sump is under a constant positive pressure at ambient temperature. To remove oil, open the service valve on the bottom of the oil sump and drain the oil into a suitable container as follows:. Important: Isolate or remove refrigerant prior to this procedure.

1. Connect a line to the oil sump drain valve.
2. Open the valve and drain the desired amount of oil into a container.
3. Close the charging valve.
4. Measure and record the exact amount of oil removed.

## Oil Charging

**Important:** The oil lines supplying the compressor must be filled when charging the system. Diagnostic "Loss of Oil at Compressor Stopped" will generate if the oil lines are not full at start-up.

Figure 64. Compressor ports

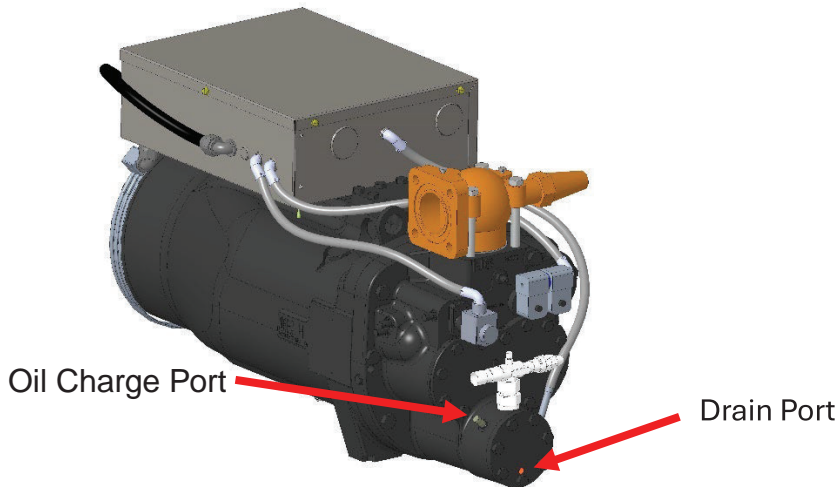

Charge the system with oil as follows:

1. Locate the schrader valve on the end of the compressor.
2. Loosely connect oil pump to the Schrader valve.
3. Operate oil charging pump until oil appears at the charging valve connection. Tighten the charging valve connection.

**Note:** To prevent air from entering the oil, the charging valve connection must be air-tight.

4. Open the service valve and pump in the required amount of oil.

**Note:** Adding oil at the oil charging port fills the oil filter cavity and the oil lines leading back to the oil separator. An internal oil valve prevents this oil from entering the compressor rotors.

## Oil Filter Replacement

Oil filter replacement may be required if either of the following diagnostics occur:

- Low Oil Flow (causing chiller shutdown)

- Loss of Oil at Compressor (Running) (causing compressor shutdown)

## Oil Sump Level Check

### ⚠ CAUTION

#### Hot Surface!

Failure to follow instructions below could result in moderate injury.

Surface temperatures can reach 150°F (66°C). To avoid possible skin burns, stay clear of these surfaces. If possible, allow surfaces to cool before servicing. If servicing is necessary while surface temperatures are still elevated, you **MUST** put on all Personal Protective Equipment (PPE).

### NOTICE

#### Equipment Damage!

Operating compressors with service valves open will result in severe oil loss and equipment damage.

Never operate the compressor with the sight glass service valves opened. Close the valves after checking the oil level.

The oil level in the oil sump can be measured to give an indication of the system oil charge. Follow the procedures below to measure the level.

1. Run the unit fully unloaded for approximately 20 minutes.
2. Cycle the compressor off line.

**Figure 65. Determine oil level in the sump**

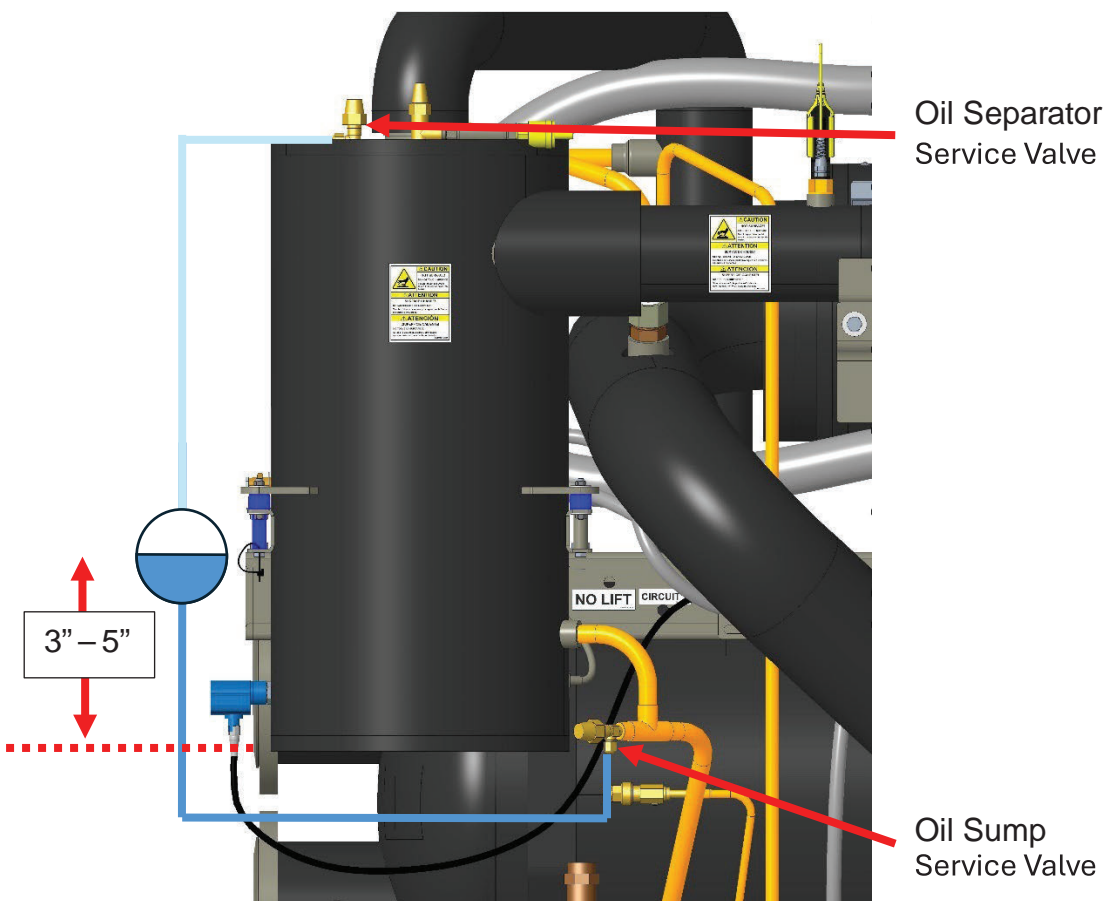

3. Attach a 3/8-inch or 1/2-inch hose with a sight glass in the middle to the oil sump service valve (1/4 inch flare) and the oil separator service valve (1/4 inch flare).

**Note:** Using high pressure rated clear hose with appropriate fittings can help speed up the process.

4. After the unit is off line for 30 minutes, move the sight glass along the side of the oil sump.
5. The oil level should be between 3 to 5 inches from the bottom of the oil sump. A reading above 5 inches indicates a full oil sump. The system likely has excess oil. Remove oil as needed until the level returns to the 3- to 5-inch range.

**Note:** If oil levels are not between 3 to 5 inches, contact Trane Service.

6. If the level is below 3 inches, the sump has insufficient oil. This can occur from low system oil levels, or migration to the evaporator. Oil migration can occur from a low refrigerant charge, oil return system malfunction, or other conditions.

**Note:** If the oil is found in the evaporator, confirm the operation of the oil return system. If the oil return system is not functioning properly, all oil will be in the evaporator.

7. After oil level is determined, close the service valves and remove the hose/sight glass assembly.

## Refrigerant System

If a low refrigerant charge is suspected, first determine the cause of lost refrigerant. Once the problem is resolved, follow the procedures below for evacuating and charging the unit.

### Evacuation and Dehydration

1. Disconnect ALL power before/during evacuation.
2. Connect the vacuum pump to the 5/8-inch flare connection on the bottom of the evaporator and/or condenser.
3. Pull the system down below 500 microns to remove all the moisture from the system and for a leak-free unit.
4. Perform a standing rise test, after the unit is evacuated, for at least an hour. If the pressure rises more than 150 microns, either a leak is present or moisture is still in the system.

**Note:** If oil is in the system, this test is more difficult. The oil is aromatic and will give off vapors that will raise the pressure of the system.

### Adding Refrigerant Charge

See *Series R® Heat Pump Chiller Model RTZA Installation, Operation, and Maintenance (RLC-SVX033\*-EN)* and unit nameplate for refrigerant charge information.

Once the system is deemed leak and moisture free, use the 5/8-inch flare connections at the bottom of the evaporator and condenser to add refrigerant charge.

## NOTICE

### Equipment Damage!

Failure to follow all instructions could result in equipment damage.

Add field refrigerant charge only through the service valve on the liquid line, not the service valves on the evaporator. Ensure that water is flowing through the evaporator during the charging process.

### Refrigerant Filter Replacement

A dirty filter is indicated by a temperature gradient across the filter, corresponding to a pressure drop. If the temperature downstream of the filter is 4°F (2.2°C) lower than the upstream temperature, the filter should be replaced. A temperature drop can also indicate that the unit is undercharged. Confirm proper subcooling before taking temperature readings.

1. With the unit off, verify that the EXV is closed. Close liquid line isolation valve.
2. Attach hose to service port on liquid line filter flange.
3. Evacuate refrigerant from liquid line and store.
4. Remove hose.
5. Depress schrader valve to equalize pressure in liquid line with atmospheric pressure.
6. Remove bolts that retain filter flange.
7. Remove old filter element.
8. Inspect replacement filter element and lubricate o-ring. See unit nameplate for oil part number.

**Note:** Do not use POE oil; it will contaminate the system.



## Maintenance

---

9. Install new filter element in filter housing.
10. Inspect flange gasket and replace if damaged.
11. Install flange and torque bolts to 14 to 16 ft-lb (19 to 22 N·m).
12. Attach vacuum hose and evacuate liquid line.
13. Remove vacuum hose from liquid line and attach charging hose.
14. Replace stored charge in liquid line.
15. Remove charging hose.
16. Open liquid line isolation valve.

## Refrigerant and Oil Charge Management

Proper oil and refrigerant charge are essential for proper unit operation, unit performance, and environmental protection. Trained and licensed service personnel should service the heat pump only.

To determine the proper charge, use the following equations to estimate the expected approach temperatures. Compare this to actuals with the noted temperature deviation.

- Evaporator approach temperature [°F] =  $0.0135 \times \text{Condenser capacity [tons]} - 1.263$
- Condenser approach temperature [°F] =  $0.0298 \times \text{Condenser capacity [tons]} - 1.755$

The discharge superheat should be  $> 8.5^\circ\text{F}$ .

If the heat pump measurements vary significantly from values listed, problems may exist with the refrigerant and/or oil charge levels. Contact Trane Service.

## Symptoms of Incorrect Charge

### Refrigerant Under-Charge

Symptoms of refrigerant undercharge unit include:

- Discharge superheat  $< 8.5^\circ\text{F}$
- Bubbles in EXV sight glass
- Low liquid level diagnostic
- Evaporator approach temperature (evaporator leaving water temperature - saturated refrigerant evaporator temperature) deviates more than  $2^\circ\text{F}$  from the above evaporator approach curve.
- Fully open expansion valve
- Possible whistling sound coming from liquid line (due to high vapor velocity)

### Refrigerant Over-Charge

Symptoms of refrigerant over-charge include:

- Evaporator liquid level higher than centerline after shutdown
- Condenser approach temperature (saturated refrigerant condenser temperature - condenser leaving water temperature) deviates more than  $3^\circ\text{F}$  from the above condenser approach curve.
- High pressure cutout diagnostic
- Higher than normal compressor power
- Very low discharge superheat at start-up
- Compressor rattle at start-up
- Fully open discharge superheat valve

### Oil Over-Charge

Symptoms of oil over-charge include:

- Evaporator approach temperature (evaporator leaving water temperature - saturated refrigerant evaporator temperature) deviates more than  $2^\circ\text{F}$  from the above evaporator approach curve.

- Low evaporator refrigerant temperature limit
- Erratic liquid level control
- Low unit capacity
- Low discharge superheat (especially at high loads)
- Low liquid level diagnostics
- High oil sump level after normal shutdown

### **Oil Under-Charge**

Symptoms of oil under-charge include:

- Compressor rattle or grinding sound
- Lower than normal pressure drop through oil system
- Seized or welded compressors
- Low oil sump level after normal shutdown
- Lower than normal oil concentrations in evaporator
- Repeated loss of oil trips



# Diagnostics

## General Diagnostics Information

**Diagnostic Name and Source:** Name of diagnostic and its source.

**Note:** This is the exact text used in the User Interface and/or Service Tool displays.

**Affects Target:** Defines the "target" or what is affected by the diagnostic. Usually, either the entire heat pump, or a particular circuit or compressor is affected by the diagnostic (the same one as the source), but, in special cases, functions are modified or disabled by the diagnostic. "None" implies that there is no direct effect to the heat pump, sub components, or functional operation.

**Design Note:** Functions that are affected by a diagnostic are reported as "chiller or circuit x" targets in Tracer® TU and on the Alarms page of the AdaptiView™ display, even though only a specific function and not the entire circuit or chiller would be affected.

**Severity:** Defines the severity of the above effect.

- "Immediate": immediate shutdown of the affected portion
- "Normal": normal shutdown of the affected portion
- "Special Action": a special action or mode of operation (limp along) is invoked, but without shutdown
- "Info": informational note or warning is generated.

**Note:** Tracer TU does not support display of "Special Action" on its Diagnostics pages, so that if a diagnostic has a special action defined in the following table will be displayed only as "Informational Warning" as long as no circuit or chiller shutdown results. If there is a shutdown and special action is defined in the table, then the Tracer TU Diagnostics Page display will indicate the shutdown type only.

**Persistence:** Defines whether or not the diagnostic and its effects need to be rest manually (latched), or automatically reset when and if the condition returns to normal (non-latched).

**Active [Inactive] Modes:** States the modes or periods of operation that the diagnostic is active. If necessary, those modes or periods that it is specifically "not active" in as an exception to the active modes. The inactive modes are enclosed in brackets—[ ]].

**Note:** The modes used in this column are internal and not generally shared to any of the formal mode displays.

## Starter Diagnostics

Table 32. Starter diagnostics

Diagnostic Name and Source	Severity	Persistence	Active Modes [Inactive Modes]	Criteria	Reset Level
Compressor Did Not Accelerate: Shutdown - xy	Immediate	Latch	Cprsr Accelerating	Acceleration Time Out Action set to Shutdown: Compressor motor current did not drop below 85% RLA within the Maximum Acceleration Setting setpoint. Compressor motor de-energized. See Current Overload Protection specification.	Local
Compressor Did Not Accelerate: Transition - xy	Warning	Latch	Start Mode	The compressor did not come up to speed (fall to <85%RLA) in the allotted time defined by the Maximum Acceleration Timer and a transition was forced (motor put across the line) at that time. This applies to all starter types.	Remote

**Table 32. Starter diagnostics (continued)**

Diagnostic Name and Source	Severity	Persistence	Active Modes [Inactive Modes]	Criteria	Reset Level
Motor Current Overload - xy	Immediate	Latch	Cprsr Energized	Compressor current exceeded overload time vs. trip characteristic. Must trip = 140% RLA, Must hold=125%, nominal trip 132.5% in 30 seconds	Local
Over Voltage	Normal	NonLatch	Pre-Start and Any Ckt (s) Energzd	Nom. trip: 60 seconds at greater than 112.5%, $\pm 2.5\%$ , Auto Reset at 110% or less for 10 continuous seconds.	Remote
Phase Loss - xy	Immediate	Latch	Start Sequence and Run modes	a) No current was sensed on one or two of the current transformer inputs while running or starting (See Non-latching Power Loss Diagnostic for all three phases lost while running). Must hold = 20% RLA. Must trip = 5% RLA. Time to trip shall be longer than guaranteed reset on Starter Module at a minimum, 3 seconds maximum. Actual design trip point is 10%. The actual design trip time is 2.64 seconds. b) If Phase reversal protection is enabled and current is not sensed on one or more current transformer inputs. Logic will detect and trip in a maximum of 0.3 seconds from compressor start.	Local
Phase Reversal - xy	Immediate	Latch	Compressor energized to transition command [All Other Times]	A phase reversal was detected on the incoming current. On a compressor startup, the phase reversal logic must detect and trip in a maximum of .3 second from compressor start.	Local

**Table 32. Starter diagnostics (continued)**

Diagnostic Name and Source	Severity	Persistence	Active Modes [Inactive Modes]	Criteria	Reset Level
Power Loss - xy	Immediate	NonLatch	All compressor running modes [all compressor starting and non-running modes]	The compressor had previously established currents while running and then all three phases of current were lost. Design: Less than 10% RLA, trip in 2.64 seconds. This diagnostic will preclude the Phase Loss Diagnostic and the Transition Complete Input Opened Diagnostic from being called out. To prevent this diagnostic from occurring with the intended disconnect of main power, the minimum time to trip must be greater than the guaranteed reset time of the Starter module. Note: This diagnostic prevents nuisance latching diagnostics due to a momentary power loss – It does not protect motor/compressor from uncontrolled power reapplication. See Momentary Power Loss Diagnostic for this protection. This diagnostic is not active during the start mode before the transition complete input is proven. Thus a random power loss during a start would result in either a “Starter Fault Type 3” or a “Starter Did Not Transition” latching diagnostic.	Remote
Severe Current Imbalance - xy	Immediate	Latch	All Running Modes	A 30% Current Imbalance has been detected on one phase relative to the average of all 3 phases for 90 continuous seconds.	Local
Starter Comm Loss: Main Processor - xy	Immediate	Latch	All	The Starter module detected a continual loss of communication with the main processor for greater than the Communications Loss Time bound setpoint.	Local

**Table 32. Starter diagnostics (continued)**

Diagnostic Name and Source	Severity	Persistence	Active Modes [Inactive Modes]	Criteria	Reset Level
Starter Contactor Interrupt Failure - xy	Immediate and Special Action	Latch	Starter Contactor not Energized [Starter Contactor Energized]	Detected compressor currents greater than 10% RLA on any or all phases when the compressor was commanded off. Detection time shall be 5 second minimum and 10 seconds maximum. On detection and until the controller is manually reset: generate diagnostic, energize the appropriate alarm relay, continue to command the affected compressor off, fully unload the effected compressor, and command a normal stop to all other compressors. For as long as current continues, keep both the Evap and Cond pumps in an override-on mode, perform liquid level, oil return, and condenser head pressure control on the circuit effected.	Local
Starter Did Not Transition - xy	Immediate	Latch	On the first check after transition	The Starter Module did not receive a transition complete signal in the designated time from its command to transition. The Must Hold time from the Starter Module transition command is 1 second. The Must Trip time from the transition command is 6 seconds. Actual design is 2.5 seconds. This diagnostic is active only for Y-Delta, Auto-Transformer, Primary Reactor, and X-Line Starters.	Local
Starter Dry Run Test - xy	Immediate	Latch	Starter Dry Run Mode	While in the Starter Dry Run Mode either 50 % Line Voltage was sensed at the Potential Transformers or 10 % RLA Current was sensed at the Current Transformers.	Local
Starter Failed to Arm/Start - xy	Immediate	Latch	All	Starter failed to arm or start within the allotted time (15 seconds).	Local

**Table 32. Starter diagnostics (continued)**

Diagnostic Name and Source	Severity	Persistence	Active Modes [Inactive Modes]	Criteria	Reset Level
Starter Fault Type I - xy	Immediate	Latch	Starting - Y Delta Starters Only	This is a specific starter test where 1M(1K1) is closed first and a check is made to ensure that there are no currents detected by the CT's. If currents are detected when only 1M is closed first at start, then one of the other contactors is shorted.	Local
Starter Fault Type II - xy	Immediate	Latch	Starting - All types of starters	a. This is a specific starter test where the Shorting Contactor (1K3) is individually energized and a check is made to ensure that there are no currents detected by the CT's. If current is detected when only S is energized at Start, then 1M is shorted. b. This test in a. above applies to all forms of starters (Note: It is understood that many starters do not connect to the Shorting Contactor.).	Local
Starter Fault Type III - xy	Immediate	Latch	Starting [Adaptive Frequency Starter Type]	As part of the normal start sequence to apply power to the compressor, the Shorting Contactor (1K3) and then the Main Contactor (1K1) were energized. 1.6 seconds later there were no currents detected by the CT's for the last 1.2 Seconds on all three phases. The test above applies to all forms of starters except Adaptive Frequency Drives.	Local
Starter Module Memory Error Type 1 - xy	Warning	Latch	All	Checksum on RAM copy of the Starter LLID configuration failed. Configuration recalled from EEPROM.	Local
Starter Module Memory Error Type 2 - xy	Immediate	Latch	All	Checksum on EEPROM copy of the Starter LLID configuration failed. Default configuration loaded into RAM and EEPROM.	Local

**Table 32. Starter diagnostics (continued)**

Diagnostic Name and Source	Severity	Persistence	Active Modes [Inactive Modes]	Criteria	Reset Level
Transition Complete Input Opened - xy	Immediate	Latch	All Running Modes	The Transition Complete input was found to be opened with the compressor motor running after a successful completion of transition. This is active only for Y-Delta, Auto-Transformer, Primary Reactor, and X-Line Starters. To prevent this diagnostic from occurring as the result of a power loss to the contactors, the minimum time to trip must be greater than the trip time for the power loss diagnostic.	Local
Transition Complete Input Shorted - xy	Immediate	Latch	Pre-Start	The Transition Complete input was found to be shorted before the compressor was started. This is active for all electromechanical starters.	Local
Under Voltage	Normal	NonLatch	Pre-Start and Any Ckt (s) Energzd	Nom. trip: 60 seconds at less than 87.5%, $\pm 2.8\%$ at 200V $\pm 1.8\%$ at 575V, Auto Reset at 90% or greater for 10 continuous seconds.	Remote
Unexpected Starter Shutdown - xy	Normal	NonLatch	All Cprsr Running modes, Starting, Running and Preparing to Shutdown	The Starter module status reported back that it is stopped when the MP thinks it should be running and no Starter diagnostic exist. This diagnostic will be logged in the active buffer and then automatically cleared. This diagnostic could be caused by intermittent communication problems from the Starter to the MP, or due to mis-binding. This defect does not apply to GP4 compressor as it already has 'AFD Unexpected Shutdown - xA'	Local

# Main Processor Diagnostics

**Table 33. Main processor diagnostics**

Diagnostic Name and Source	Severity	Persistence	Active Modes [Inactive Modes]	Criteria	Reset Level
Chiller Service Recommended	Warning	Latch	Service Messages Enabled	Chiller service interval time has elapsed. Chiller service is recommended.	Remote
Compressor Discharge Refrigerant Temperature Sensor - xy	Immediate	Latch	All	Bad Sensor or LLID	Remote
Condenser Diff Water Pressure Xdcr	Immediate or Warning ( <i>see note</i> )	Latch	All	Bad Sensor or LLID a. Display invalid value b. Flow calculation shall be disabled. See Water_Flow_and_Tons_Sensing.doc specification for additional information If used for flow proving then severity is Immediate Shutdown; otherwise, Warning.	Remote
Condenser Entering Water Pressure	Immediate or Warning ( <i>see note</i> )	Latch	All	Bad Sensor or LLID a. Display invalid value b. Flow calculation shall be disabled. See Water_Flow_and_Tons_Sensing.doc specification for additional information If used for flow proving then severity is Immediate Shutdown; otherwise, Warning.	Remote
Condenser Entering Water Temperature Sensor	Warning and Special Action	Latch	All	Bad Sensor or LLID. If chiller running, and condenser water regulating valve option installed, force valve to 100% flow.	Remote
Condenser Leaving Water Pressure	Immediate or Warning ( <i>see note</i> )	Latch	All	Bad Sensor or LLID a. Display invalid value b. Flow calculation shall be disabled. See Water_Flow_and_Tons_Sensing.doc specification for additional information If used for flow proving then severity is Immediate Shutdown; otherwise, Warning.	Remote
Condenser Leaving Water Temperature Sensor	Warning and Special Action	Latch	All	Bad Sensor or LLID. If Chiller is running in the heat mode of operation – normal chiller shutdown, otherwise, informational warning only. Discontinue Min Capacity Limit forced cprsr loading due to Low DP in subsequent startups.	Remote
Condenser Refrigerant Pressure Sensor	Immediate	Latch	All	Bad Sensor or LLID	Remote

**Table 33. Main processor diagnostics (continued)**

Diagnostic Name and Source	Severity	Persistence	Active Modes [Inactive Modes]	Criteria	Reset Level
Condenser Water Flow Lost	Immediate	NonLatch	Cond Water Flow Previously Established – Start and all Run Modes [All Stop modes]	Loss of condenser water flow either by the measured flow went below adjustable Minimum Cond Water Flow Proving Threshold or the proof of flow input was open for more than 6 contiguous seconds (when using flow switch) after flow had been proven. This diagnostic will keep the condenser and evaporator pump relays energized through diagnostic override. The diagnostic is auto-reset with return of flow.	Remote
Condenser Water Flow Overdue	Normal	NonLatch	Start Sequence Attempting to Establish Condenser Flow [All Stop modes]	Condenser water flow was not proven within 20 minutes of the Condenser Water Pump relay being energized. This diagnostic will de-energize the condenser pump relay. The diagnostic is auto-reset with return of flow (although only possible with external control of pump).	Remote
Emergency Stop Feedback Input	Immediate	Latch	All	a. Emergency stop feedback input is open. An external interlock has tripped. Time to trip from input opening to unit stop shall be 0.1 to 1.0 seconds.	Local
Energy Meter Write Value Failure	Warning	Latch	All	Energy meter failed to return the expected value. <i>(Only applies to Veris Energy Meter)</i>	Remote
Evaporator Approach Error	Immediate	Latch	Respective circuit running	The Evaporator approach temperature for the respective circuit (ELWT – Evap Sat Temp Ckt x) is negative by more than $\max(10^{\circ}\text{F}, \text{Cooling Design Delta Temp (waterside)})$ for 1 minute continuously while the circuit / compressor is operating. Either the Evap Leaving Water Temp sensor or Evap Suction Rfgr Pressure Sensor Ckt x is in error. note: 'Cooling Design Delta Temp(waterside)' is the TU setpoint	Remote

**Table 33. Main processor diagnostics (continued)**

Diagnostic Name and Source	Severity	Persistence	Active Modes [Inactive Modes]	Criteria	Reset Level
Evaporator Diff Water Pressure Xdcr	Immediate or Warning <i>(see note)</i>	Latch	All	Bad Sensor or LLID a. Display invalid value b. Flow calculation shall be disabled. See Water_Flow_and_Tons_Sensing.doc specification for additional information If used for flow proving then severity is Immediate Shutdown; otherwise, Warning.	Remote
Evaporator Entering Water Pressure	Immediate or Warning <i>(see note)</i>	Latch	All	Bad Sensor or LLID a. Display invalid value b. Flow calculation shall be disabled. See Water_Flow_and_Tons_Sensing.doc specification for additional information If used for flow proving then severity is Immediate Shutdown; otherwise, Warning.	Remote
Evaporator Entering Water Temperature Sensor	Normal	Latch	All	Bad Sensor or LLID. Note: Entering Water Temp Sensor is used in EXV pressure control as well as ice making so it must cause a unit shutdown even if ice or CHW reset is not installed.	Remote
Evaporator Leaving Water Pressure	Immediate or Warning <i>(see note)</i>	Latch	All	Bad Sensor or LLID a. Display invalid value b. Flow calculation shall be disabled. See Water_Flow_and_Tons_Sensing.doc specification for additional information If used for flow proving then severity is Immediate Shutdown; otherwise, Warning.	Remote
Evaporator Leaving Water Temperature Sensor	Normal	Latch	All	Bad Sensor or LLID	Remote
Evaporator Refrigerant Liquid Level Sensor, Circuit X	Normal	Latch	All	Bad Sensor or LLID	Remote
Evaporator Shell Rfgt Pressure Sensor	Normal	Latch	All	Bad Sensor or LLID	Remote

**Table 33. Main processor diagnostics (continued)**

Diagnostic Name and Source	Severity	Persistence	Active Modes [Inactive Modes]	Criteria	Reset Level
Evaporator Water Flow Lost	Immediate	NonLatch	[All Stop Modes]	Loss of evaporator water flow either by the measured flow went below adjustable Minimum Evap Water Flow Proving Threshold or the proof of flow input was open for more than 6 contiguous seconds (when using flow switch). This diagnostic will keep the evaporator pump relay energized through diagnostic override. This diagnostic shall auto-reset when flow returns after the flow status debounce time.	Remote
Evaporator Water Flow Overdue	Normal	NonLatch	Estab. Evap. Water Flow on going from STOP to AUTO or Evap Pump Override	The evaporator water flow was not proven within 20 minutes of the Evaporator Water Pump Relay being energized in normal "Stop" to "Auto" transition. In the case where the pump is overridden to "On" per certain freeze avoidance diagnostics, the delay on the callout of this diagnostic will be shortened to 255 seconds. This diagnostic will keep the evaporator pump relay energized through diagnostic override.	Remote
Excessive Condenser Pressure	Immediate	Latch	All	The condenser pressure sensor of this circuit has detected a condensing pressure in excess of the design high side pressure as limited by the particular compressor type.	Remote
External Chilled Water Setpoint	Warning	NonLatch	All	a. Function Not "Enabled": no diagnostics. b. "Enabled ": Out-Of-Range Low or Hi or bad LLID, set diagnostic, default CWS to next level of priority (e.g. Front Panel SetPoint).	Remote
External Demand Limit Setpoint	Warning	Latch	All	a. Not "Enabled": no diagnostics. b. "Enabled ": Out-Of-Range Low or Hi or bad LLID, set diagnostic, default CLS to next level of priority (e.g. Front Panel SetPoint.)	Remote

**Diagnostics**
**Table 33. Main processor diagnostics (continued)**

Diagnostic Name and Source	Severity	Persistence	Active Modes [Inactive Modes]	Criteria	Reset Level
External Hot Water Setpoint	Warning	NonLatch	All	a. Function Not "Enabled": no diagnostics. b. "Enabled ": Out-Of-Range Low or Hi or bad LLID, set diagnostic, default HWS to next level of priority (e.g. Front Panel SetPoint).	Remote
High Compressor Refrigerant Discharge Temp - xy	Immediate	Latch	All [compressor run unload or compressor not running]	The compressor discharge temperature exceeded 302°F	Remote
High Compressor Suction Saturated Temperature	Normal	NonLatch	All	The compressor suction saturated refrigerant temperature exceeded 125 deg F for 5000 deg F * sec. This diagnostic will auto clear when the compressor suction saturated refrigerant temperature drops below the cutout.	Remote
High Condenser Water Temperature Cutout	Immediate	Latch	All	The thermal switch monitoring the condenser leaving water temperature trip was detected.	Local
High Differential Refrigerant Pressure - xy	Normal	Latch	Cprsr Energized	The differential pressure for the respective compressor was above 275 psid (1890 kPa) for 2 consecutive samples 5 seconds apart.	Remote

**Table 33. Main processor diagnostics (continued)**

Diagnostic Name and Source	Severity	Persistence	Active Modes [Inactive Modes]	Criteria	Reset Level
High Evaporator Water Temperature	Warning and Special Action	NonLatch	Only effective if either 1) Evap Wtr Flow Overdue, 2) Evap Wtr Flow Loss, or 3) Low Evap Rfgt Temp,-Unit Off, diagnostic is active.	Either the leaving or the entering water temperature exceeded the high evap water temp limit (TU service menu settable –default 145°F (62.77°C), range 80°F (26.67°C)-145°F (62.77°C) for 15 continuous seconds. The evaporator water pump relay will be de-energized to stop the pump but only if it is running due one of the diagnostics listed on the left. The diagnostic will auto reset and the pump will return to normal control when both the entering and leaving temperatures fall 5°F below the trip setting. The primary purpose is to stop the evaporator water pump and its associated pump heat from causing excessive waterside temperatures and waterside pressures when the chiller is not running but the evap pump is on due to either Evap Water Flow Overdue, Evaporator Water Flow Loss , or Low Evap Temp – Unit Off Diagnostics. This diagnostic will not auto clear solely due to the clearing of the enabling diagnostic.	Remote
High Pressure Cutout - xy	Immediate	Latch	All	A high pressure cutout was detected. When a high pressure cutout occurs, a shunt trip circuit breaker in the low voltage control panel trips. The shunt trip circuit breaker must be manually reset to allow the compressor to start. If the shunt trip is not reset, the High Pressure Cutout alarm will re-occur after every front panel Alarm Reset.	Local

**Diagnostics**
**Table 33. Main processor diagnostics (continued)**

Diagnostic Name and Source	Severity	Persistence	Active Modes [Inactive Modes]	Criteria	Reset Level
High Refrigerant Pressure Ratio - xy	Immediate	Latch	Cprsr Energized	The pressure ratio for the respective compressor exceeded 12.3 for 1 contiguous minute while any compressor is running normally or in service pumpdown. This pressure ratio is a fundamental limitation of the particular compressor design. The pressure ratio is defined as $P_{cond} (abs) / P_{evap} (abs)$ .	Remote
Inverted Condenser Water Temperature	Warning/Normal	NonLatch/Latch	Any Ckt Energized [No Ckts Energized]	The leaving condenser water temp fell below the entering condenser water temp by more than 2°F for 180 °F-sec, minimum trip time 30 seconds. Diagnostic will auto clear if the entering water temp – leaving water temp < 2F. It can detect improper flow direction through the condenser, misbound water temperature sensors, improper sensor installation, grossly inaccurate sensors, or other system problems. Note that either entering or leaving water temp sensor or the water system could be at fault. * Inverted Water Temp Diagnostic Severity setting determines diagnostic severity and persistence (Warning/ NonLatch; Normal/ Latch).	Remote

**Table 33. Main processor diagnostics (continued)**

Diagnostic Name and Source	Severity	Persistence	Active Modes [Inactive Modes]	Criteria	Reset Level
Inverted Evaporator Water Temperature	Warning/Normal	NonLatch/Latch	Any Ckt Energized [No Ckts Energized]	The entering evaporator water temp fell below the leaving evaporator water temp by more than 2°F for 180 °F-sec, minimum trip time 30 seconds. Diagnostic will auto clear if the leaving water temp – entering water temp < 2F. It can detect improper flow direction through the evaporator, misbound water temperature sensors, improper sensor installation, grossly inaccurate sensors, or other system problems. Note that either entering or leaving water temp sensor or the water system could be at fault. * Inverted Water Temp Diagnostic Severity setting determines diagnostic severity and persistence (Warning/ NonLatch; Normal/ Latch).	Remote
Loss of Oil for Compressor (Running)	Immediate	Latch	Starter Contactor Energized	In running modes, Oil Loss Level Sensor detects lack of oil in the oil sump feeding the compressor (distinguishing a liquid flow from a vapor flow).	Local
Loss of Oil for Compressor (Stopped)	Immediate and Special Action	Latch	Compressor Pre-Start [all other modes]	Oil Loss Level Sensor detects a lack of oil in the oil sump feeding the compressor for 90 seconds after EXV preposition is completed (and before EXV equalization, if applicable) on an attempted circuit start. Note: Compressor start is delayed pending oil detection during that time, but not allowed once the diagnostic occurs.	Local



## Diagnostics

**Table 33. Main processor diagnostics (continued)**

Diagnostic Name and Source	Severity	Persistence	Active Modes [Inactive Modes]	Criteria	Reset Level
Low Condenser Rfgt Temp Circuit 1: Unit Off	Special Action	NonLatch	Unit in Stop Mode, or in Auto Mode and No Ckt (s) Energized [Any Ckt Energized]	This diagnostic is based on dew point from condenser refrigerant pressure transducer of circuit 1 falling below the Condenser Freeze Avoidance Setpoint. When this diagnostic is active, both the Condenser Water Freeze Avoidance Request Relay is turned on and the Condenser Water Pump request is placed in a "Diagnostic Override mode" and forced on regardless of the chiller mode. The diagnostic is auto cleared when both the saturated temperature is 2F (1.1C) above the Condenser Freeze Avoidance Setpoint for 1 minute and the anti short cycling count down calculation reaches 0(see Low Rfgt Condenser Temperature Protection spec), or with the start of either circuit. This diagnostic even while active, does not prevent operation of either circuit.	Remote

**Table 33. Main processor diagnostics (continued)**

Diagnostic Name and Source	Severity	Persistence	Active Modes [Inactive Modes]	Criteria	Reset Level
Low Condenser Rfgt Temp Circuit 2: Unit Off	Special Action	NonLatch	Unit in Stop Mode, or in Auto Mode and No Ckt (s) Energized [Any Ckt Energized]	This diagnostic is based on dew point from condenser refrigerant pressure transducer of circuit 2 falling below the Condenser Freeze Avoidance Setpoint. When this diagnostic is active, both the Condenser Water Freeze Avoidance Request Relay is turned on and the Condenser Water Pump request is placed in a "Diagnostic Override mode" and forced on regardless of the chiller mode. The diagnostic is auto cleared when both the saturated temperature is 2F (1.1C) above the Condenser Freeze Avoidance Setpoint for 1 minute and the anti short cycling count down calculation reaches 0(see Low Rfgt Condenser Temperature Protection spec), or with the start of either circuit. This diagnostic even while active, does not prevent operation of either circuit.	Remote
Low Condenser Water Flow	Warning	NonLatch	Chiller Auto, manual water pump and All Running Modes	a. The cond. water flow measurement option was installed and the flow dropped to or below the Condenser Low Water Flow Warning Setpoint. This diagnostic shall be Auto Reset when flow is (0.1 gpm/ton * NTON) above the adjustable trippoint or when the Condenser water pump is turned off. b. See Water_Flow_and_Tons_Sensing.doc specification for additional information.	Remote

**Table 33. Main processor diagnostics (continued)**

Diagnostic Name and Source	Severity	Persistence	Active Modes [Inactive Modes]	Criteria	Reset Level
Low Differential Refrigerant Pressure - xy	Immediate	Latch	Cprsr Energized	For startup, please refer to oil flow protection spec. For running, the system differential pressure for the respective circuit was below the greater of 25 psid (240.5 kPa) or the pressure ratio listed in the table in GP2 Compressor Type FSpec while the compressor is running for a period of time dependent on the deficit (15 sec ignore time from circuit start) – refer to the Oil Flow Protection specification for the time to trip function.	Remote
Low Discharge Superheat - xy	Normal	Latch	Any Running Mode	While Running Normally, the Compressor Discharge Superheat was less than the Low Discharge Superheat Setpoint (default 10F) for more than 6500 degree F seconds. At circuit startup, the Discharge Superheat will be ignored for 5 minutes.	Remote
Low Evaporator Refrigerant Pressure	Immediate	Latch	Cprsr Prestart and Cprsr Energized	a. The Evaporator Pressure (as measured by the compressor suction pressure transducer) for the respective circuit, dropped below 5 Psia just prior to the circuit's 1st compressor start (during EXV preposition). b. During Early Startup Period: the Evaporator Pressure fell below 10 6 psia. c. After Early Startup Period expires: The Evaporator Pressure fell below 7 Psia.	Local

**Table 33. Main processor diagnostics (continued)**

Diagnostic Name and Source	Severity	Persistence	Active Modes [Inactive Modes]	Criteria	Reset Level
Low Evaporator Refrigerant Temperature Circuit 1: Unit Off	Special Action	NonLatch	Unit in Stop Mode, or in Auto Mode and No Ckt (s) Energized [Any Ckt Energized]	The respective circuit's LERTC Integral was seen to be > 0 while the chiller is in the Stop mode, or in Auto mode with no compressors running for at least one minute. The LERTC integral is increased if the Evap Refrigerant Saturated Temp (derived from Evap Shell Pressure) is below the value of the Low Evap Rfgt Temp Cutout + 2°F. Energize Evap Water Pump and Off-Cycle Freeze Avoidance Request Relay until diagnostic auto resets, then return to normal evap pump control and de-energize the Freeze Avoidance Request. Automatic reset occurs when the respective Evap Rfgt Sat Pool Temp rises 4° F (1.1°C) above the LERTC cutout setting for 1 minute and the Chiller Off LERTC Integral = 0.. This diagnostic even while active, does not prevent operation of either circuit.	Remote



## Diagnostics

**Table 33. Main processor diagnostics (continued)**

Diagnostic Name and Source	Severity	Persistence	Active Modes [Inactive Modes]	Criteria	Reset Level
Low Evaporator Refrigerant Temperature Circuit 2: Unit Off	Special Action	NonLatch	Unit in Stop Mode, or in Auto Mode and No Ckt (s) Energized [Any Ckt Energized]	The respective circuit's LERTC Integral was seen to be > 0 while the chiller is in the Stop mode, or in Auto mode with no compressors running for at least one minute. The LERTC integral is increased if the Evap Refrigerant Saturated Temp (derived from Evap Shell Pressure) is below the value of the Low Evap Rfght Temp Cutout + 2°F. Energize Evap Water Pump and Off-Cycle Freeze Avoidance Request Relay until diagnostic auto resets, then return to normal evap pump control and de-energize the Freeze Avoidance Request. Automatic reset occurs when the respective Evap Rfght Sat Pool Temp rises 4° F (1.1°C) above the LERTC cutout setting for 1 minute and the Chiller Off LERTC Integral = 0. This diagnostic even while active, does not prevent operation of either circuit.	Remote
Low Evaporator Refrigerant Temperature	Immediate	Latch	All Ckt Running Modes	Evap Refrigerant Saturated Temp (derived from Evap Shell Pressure) for the respective circuit dropped below the Low Refrigerant Temperature Cutout Setpoint for 1125°F-sec (12°F-sec max rate for early circuit startup period) while the circuit was running. The minimum LRTC setpoint is -5°F the point at which oil separates from the refrigerant. The integral is held nonvolatile though power down, is continuously calculated, and can decay or build during the circuit off cycle as conditions warrant.	Local

**Table 33. Main processor diagnostics (continued)**

Diagnostic Name and Source	Severity	Persistence	Active Modes [Inactive Modes]	Criteria	Reset Level
Low Evaporator Water Flow	Warning	NonLatch	Chiller Auto, manual water pump and All Running Modes	a. The evap. water flow measurement option was installed and the flow dropped to or below the Evaporator Low Water Flow Warning Setpoint. This diagnostic shall be Auto Reset when flow is (0.1 gpm/ton * NTON) above the adjustable trippoint or when the Evaporator water pump is turned off. b. See Water_Flow_and_Tons_Sensing.doc specification for additional information.	Remote
Low Evaporator Water Temperature (Unit Off)	Special Action	NonLatch	Unit in Stop Mode, or in Auto Mode and No Ckt(s) Energized [Any Ckt Energized]	Either the entering or leaving evaporator water temp fell below the leaving water temp cutout setting for 30 degree F-seconds while the Chiller is in the Stop mode, or in Auto mode with no compressors running. Energize Freeze Avoidance Request Relay and Evap Water Pump Relay until diagnostic auto resets, then de-energize the Freeze Avoidance Request Relay and return to normal evap pump control. Automatic reset occurs when both temps rise 2°F(1.1°C) above the cutout setting for 5 minutes, or either circuit starts. This diagnostic even while active, does not prevent operation of either circuit.	Remote
Low Evaporator Water Temperature (Unit On)	Immediate and Special Action	NonLatch	Any Ckt[s] Energized [No Ckt(s) Energized]	The evaporator entering or leaving water temperature fell below the cutout setpoint for 30 degree F Seconds while the compressor was running. Automatic reset occurs when both of the temperature rises 2°F(1.1°C) above the cutout setting for 2 minutes. This diagnostic shall not de-energize the Evaporator Water Pump Output.	Remote

**Table 33. Main processor diagnostics (continued)**

Diagnostic Name and Source	Severity	Persistence	Active Modes [Inactive Modes]	Criteria	Reset Level
Low Oil Flow - xy	Immediate	Latch	Cprsr Energized and Delta P above 15 Psid	The intermediate oil pressure sensor for this compressor was out of the acceptable pressure range for 15 seconds, while the Delta Pressure was greater than 15 Psid (172.4 kPa).: Acceptable range is 0.50 (PC-PI) / (PC-PE) for the first 2.5 minutes of operation, and 0.28 > (PC-PI) / (PC-PE) thereafter.	Local
Manufacturer Maintenance Recommended - xy	Warning	Latch	Service Messages Enabled	Compressor service recommended as service interval hours have elapsed.	Remote
MP: Invalid Configuration	Immediate	Latch	All	Reported if state chart misalignment in stopped or inactive state occurred while a compressor was seen to be operating and this condition lasted for at least 1 minute (cprsr operation due to Service Pumpdown or with Contactor Interrupt Failure diagnostic is excluded). The presence of this software error message suggests an internal software problem has been detected. The events that led up to this failure, if known, should be recorded and transmitted to Trane Controls Engineering.	Local
MP: Reset Has Occurred	Warning	NonLatch	All	The main processor has successfully come out of a reset and built its application. A reset may have been due to a power up, installing new software or configuration. This diagnostic is immediately and automatically cleared and thus can only be seen in the Historic Diagnostic List in Tracer TU.	Remote
No Differential Refrigerant Pressure - xy	Immediate	Latch	Compressor running on Circuit	The system differential pressure was below 7.7 Psid (53 kPa) for 6 seconds after the 11 seconds ignore time relative to cprsr/circuit startup had expired. In a two compressor circuit, the lower of the two suction pressure is used for circuit DP.	Remote

**Table 33. Main processor diagnostics (continued)**

Diagnostic Name and Source	Severity	Persistence	Active Modes [Inactive Modes]	Criteria	Reset Level
Oil Flow Protection Fault - xy	Immediate	Latch	Starter Contactor Energized [all Stop modes]	The Intermediate Oil Pressure Sensor for this cprsr is reading a pressure either above its respective circuit's Condenser Pressure by 15 Psid or more, or below its respective compressor Suction Pressure 10 Psid or more for 30 seconds continuously.	Local
Oil Pressure Sensor - xy	Immediate	Latch	All	Bad Sensor or LLID	Remote
Outdoor Air Temperature Sensor	Warning	Latch	All	Bad Sensor or LLID.	Remote
Pumpdown Terminated By Time	Warning	Latch	Service Pumpdown	Service Pumpdown cycle for this circuit was terminated abnormally due to excessive time. Refer to Service Pumpdown spec for maximum time allowed.	Local
Restart Inhibit Invoked - xy	Warning	NonLatch	All	When restart inhibit warning is enabled, the warning exists when unit has been inhibited from starting and is cleared when a start of a compressor is possible (Start-to-Start Timer expires)	Remote
Software Error 1001: Call Trane Service	Immediate	Latch	All	A high level software watchdog has detected a condition in which there was a continuous 1 minute period of compressor operation, with neither Evaporator water flow nor a "contactor interrupt failure" diagnostic active. The presence of this software error message suggests an internal software problem has been detected. The events that led up to this failure, if known, should be recorded and transmitted to Trane Controls Engineering.	Local

**Diagnostics**
**Table 33. Main processor diagnostics (continued)**

Diagnostic Name and Source	Severity	Persistence	Active Modes [Inactive Modes]	Criteria	Reset Level
Software Error 1002: Call Trane Service	Immediate	Latch	All	Reported if state chart misalignment in stopped or inactive state occurred while a compressor was seen to be operating and this condition lasted for at least 1 minute (cprsr operation due to Service Pumpdown or with Contactor Interrupt Failure diagnostic is excluded). The presence of this software error message suggests an internal software problem has been detected. The events that led up to this failure, if known, should be recorded and transmitted to Trane Controls Engineering.	Local
Software Error 1003: Call Trane Service	Immediate	Latch	All	Reported if state chart misalignment occurred inferred from the Capacity Control, Circuit, or Compressor State Machines remaining in the Stopping state for more than 3 minutes. The presence of this software error message suggests an internal software problem has been detected. The events that led up to this failure, if known, should be recorded and transmitted to Trane Controls Engineering.	Local
Starter Panel High Temp Limit – Compressor 1A	Immediate and Special Action	NonLatch	All	Starter Panel High Limit Thermostat (170°F) trip was detected. Compressor 1A is shutdown and inoperative until the thermostat resets. Note: Other diagnostics that may occur as an expected consequence of the Panel High Temp Limit trip will be suppressed from annunciation. These include Momentary Power Loss, Phase Loss, Power Loss, and Transition Complete Input for Compressor 1A.	Local

**Table 33. Main processor diagnostics (continued)**

Diagnostic Name and Source	Severity	Persistence	Active Modes [Inactive Modes]	Criteria	Reset Level
Starts/Hours Modified xy	Warning	NonLatch	All	The current value for the cumulative starts and or hours for the given compressor have been modified by a write override from TU in any running mode. The diagnostic will only appear in the Historic Alarms list.	Remote
Suction Refrigerant Pressure Sensor - xy	Immediate	Latch	All	Bad Sensor or LLID	Remote
Very Low Evaporator Refrigerant Pressure - xy	Immediate	Latch	All	The respective circuit's evaporator pressure (as measured by the compressor suction pressure transducer) dropped below 80% of the current Low Evap Refrigerant Press Cutout setting (see above) or 8.5 psia, whichever is less, regardless of the running state of the circuit's compressor. Note: Unlike previous products, even if the circuit associated with the suction pressure sensor is locked out, it will not defeat the protection afforded by this diagnostic.	Local

## Communication Diagnostics

**Table 34. Communication diagnostics**

Diagnostic Name and Source	Severity	Persistence	Active Modes [Inactive Modes]	Criteria	Reset Level
Comm Loss: %RLA Indication Output(Vdc)	Warning	Latch	All	Continual loss of communication between the MP and the Functional ID has occurred for a 30 second period.	Remote
Comm Loss: Compressor Discharge Rfgt Temperature - xy	Normal	Latch	All	Continual loss of communication between the MP and the Functional ID has occurred for a 30 second period.	Remote

**Table 34. Communication diagnostics (continued)**

Diagnostic Name and Source	Severity	Persistence	Active Modes [Inactive Modes]	Criteria	Reset Level
Comm Loss: Cond Diff Water Pressure	Immediate or Warning (see note)	Latch	All	Continual loss of communication between the MP and the Functional ID has occurred for a 30 second period. Flow and tons calculation shall be disabled. Display invalid value. If used for flow proving then severity is Immediate Shutdown; otherwise, Warning.	Remote
Comm Loss: Cond Head Press Cntrl Output	Immediate	Latch	All	Continual loss of communication between the MP and the Functional ID has occurred for a 30 second period.	Remote
Comm Loss: Condenser Entering Water Pressure	Immediate or Warning (see note)	Latch	All	Continual loss of communication between the MP and the Functional ID has occurred for a 30 second period. Flow and tons calculation shall be disabled. Display invalid value. If used for flow proving then severity is Immediate Shutdown; otherwise, Warning.	Remote
Comm Loss: Condenser Entering Water Temperature	Warning	Latch	All	Continual loss of communication between the MP and the Functional ID has occurred for a 30 second period. If chiller running, and condenser water regulating valve option installed, force valve to 100% flow.	Remote
Comm Loss: Condenser Leaving Water Pressure	Immediate or Warning (see note)	Latch	All	Continual loss of communication between the MP and the Functional ID has occurred for a 30 second period. Flow and tons calculation shall be disabled. Display invalid value. If used for flow proving then severity is Immediate Shutdown; otherwise, Warning.	Remote
Comm Loss: Condenser Leaving Water Temperature	Normal	Latch	All	Continual loss of communication between the MP and the Functional ID has occurred for a 30 second period. Discontinue Min Capacity Limit forced cprsr loading due to Low DP in subsequent startups.	Remote

**Table 34. Communication diagnostics (continued)**

Diagnostic Name and Source	Severity	Persistence	Active Modes [Inactive Modes]	Criteria	Reset Level
Comm Loss: Condenser Refrigerant Pressure Output	Immediate	Latch	All	Continual loss of communication between the MP and the Functional ID has occurred for a 30 second period.	Remote
Comm Loss: Condenser Refrigerant Pressure	Immediate	Latch	All	Continual loss of communication between the MP and the Functional ID has occurred for a 30 second period.	Remote
Comm Loss: Condenser Water Flow Switch	Immediate	Latch	All	Continual loss of communication between the MP and the Functional ID has occurred for a 30 second period.	Remote
Comm Loss: Condenser Water Pump Relay	Normal	Latch	All	Continual loss of communication between the MP and the Functional ID has occurred for a 30 second period.	Remote
Comm Loss: Discharge Superheat Valve Circuit X	Warning	Latch	All	Continual loss of communication between the MP and the Functional ID has occurred for a 30 second period.	Remote
Comm Loss: Discharge Superheat Valve Relay Cktx	Warning	Latch	All	Continual loss of communication between the MP and the Functional ID has occurred for a 30 second period.	Remote
Comm Loss: Electronic Expansion Valve	Normal	Latch	All	Continual loss of communication between the MP and the EXV Step Status has occurred for a 30 second period, OR EXV Steps Maximum Position has not been received. If EXV Steps Maximum Position has not been received, MP will periodically request EXV Steps Maximum Position, since it is only transmitted upon request.	Remote
Comm Loss: Emergency Stop Feedback Input	Normal	Latch	All	Continual loss of communication between the MP and the Functional ID has occurred for a 30 second period.	Remote
Comm Loss: Energy Meter X	Warning	Latch	All	Continual loss of communication between the MP and the Power Meter has occurred for a 30 second period.	Remote

**Table 34. Communication diagnostics (continued)**

Diagnostic Name and Source	Severity	Persistence	Active Modes [Inactive Modes]	Criteria	Reset Level
Comm Loss: Evap Diff Water Pressure	Immediate or Warning (see note)	Latch	All	Continual loss of communication between the MP and the Functional ID has occurred for a 30 second period. Flow and tons calculation shall be disabled. Display invalid value. If used for flow proving then severity is Immediate Shutdown; otherwise, Warning.	Remote
Comm Loss: Evap Rfqt Liquid Level - Cktx	Normal	Latch	All	Continual loss of communication between the MP and the Functional ID has occurred for a 30 second period.	Remote
Comm Loss: Evaporator Entering Water Pressure	Immediate or Warning (see note)	Latch	All	Continual loss of communication between the MP and the Functional ID has occurred for a 30 second period. Flow and tons calculation shall be disabled. Display invalid value. If used for flow proving then severity is Immediate Shutdown; otherwise, Warning.	Remote
Comm Loss: Evaporator Entering Water Temperature	Normal	Latch	All	Continual loss of communication between the MP and the Functional ID has occurred for a 30 second period. Note: Entering Water Temp Sensor is used in EXV pressure control; therefore, must cause a unit shutdown.	Remote
Comm Loss: Evaporator Leaving Water Pressure	Immediate or Warning (see note)	Latch	All	Continual loss of communication between the MP and the Functional ID has occurred for a 30 second period. Flow and tons calculation shall be disabled. Display invalid value. If used for flow proving then severity is Immediate Shutdown; otherwise, Warning.	Remote
Comm Loss: Evaporator Leaving Water Temperature	Normal	Latch	All	Continual loss of communication between the MP and the Functional ID has occurred for a 30 second period.	Remote

**Table 34. Communication diagnostics (continued)**

Diagnostic Name and Source	Severity	Persistence	Active Modes [Inactive Modes]	Criteria	Reset Level
Comm Loss: Evaporator Shell Refrigerant Pressure	Normal	Latch	All	Continual loss of communication between the MP and the Functional ID has occurred for a 30 second period.	Remote
Comm Loss: Evaporator Water Flow Switch	Immediate	Latch	All	Continual loss of communication between the MP and the Functional ID has occurred for a 30 second period.	Remote
Comm Loss: Evaporator Water Pump Relay	Normal	Latch	All	Continual loss of communication between the MP and the Functional ID has occurred for a 30 second period.	Remote
Comm Loss: External Auto/Stop	Normal	Latch	All	Continual loss of communication between the MP and the Functional ID has occurred for a 30 second period.	Remote
Comm Loss: External Chilled Water Setpoint	Special Action	Latch	All	Continual loss of communication between the MP and the Functional ID has occurred for a 30 second period. Chiller shall discontinue use of the External Chilled Water Setpoint source and revert to the next higher priority for setpoint arbitration	Remote
Comm Loss: External Ckt Lockout - CktX	Special Action	Latch	All	Continual loss of communication between the MP and the Functional ID has occurred for a 30 second period. MP will nonvolatile hold the lockout state (enabled or disabled) that was in effect at the time of comm loss.	Remote
Comm Loss: External Demand Limit Setpoint	Special Action	Latch	All	Continual loss of communication between the MP and the Functional ID has occurred for a 30 second period. Chiller shall discontinue use of the External Demand limit setpoint and revert to the next higher priority for Demand Limit setpoint arbitration.	Remote

**Diagnostics**
**Table 34. Communication diagnostics (continued)**

Diagnostic Name and Source	Severity	Persistence	Active Modes [Inactive Modes]	Criteria	Reset Level
Comm Loss: External Hot Water Setpoint	Special Action	Latch	All	Continual loss of communication between the MP and the Functional ID has occurred for a 30 second period. Chiller shall discontinue use of the External Hot Water Setpoint source and revert to the next higher priority for setpoint arbitration	Remote
Comm Loss: High Condenser Water Temp Cutout Switch	Normal	Latch	All	Continual loss of communication between the MP and the Functional ID has occurred for a 30 second period.	Remote
Comm Loss: High Pressure Cutout Switch - xy	Normal	Latch	All	Continual loss of communication between the MP and the Functional ID has occurred for a 30 second period.	Remote
Comm Loss: Oil Loss Level Sensor Input	Normal	Latch	All	Continual loss of communication between the MP and the Functional ID has occurred for a 30 second period.	Remote
Comm Loss: Oil Pressure - xy	Immediate	Latch	All	Continual loss of communication between the MP and the Functional ID has occurred for a 30 second period.	Remote
Comm Loss: Oil Return Valve Cktx	Normal	Latch	All	Continual loss of communication between the MP and the Functional ID has occurred for a 30 second period, or the Max Steps value was never read from the associated device.	Remote
Comm Loss: Programmable Relay Board 1	Warning	Latch	All	Continual loss of communication between the MP and the Functional ID has occurred for a 30 second period.	Remote
Comm Loss: Programmable Relay Board 2	Warning	Latch	All	Continual loss of communication between the MP and the Functional ID has occurred for a 30 second period.	Remote
Comm Loss: Slide Valve Load - xy	Normal	Latch	All	Continual loss of communication between the MP and the Functional ID has occurred for a 30 second period.	Remote

**Table 34. Communication diagnostics (continued)**

Diagnostic Name and Source	Severity	Persistence	Active Modes [Inactive Modes]	Criteria	Reset Level
Comm Loss: Slide Valve Unload - xy	Normal	Latch	All	Continual loss of communication between the MP and the Functional ID has occurred for a 30 second period.	Remote
Comm Loss: Starter xy	Immediate	Latch	All	Continual loss of communication between the MP and the Functional ID has occurred for a 30 second period.	Local
Comm Loss: Step Load - xy	Normal	Latch	All	Continual loss of communication between the MP and the Functional ID has occurred for a 30 second period.	Remote
Comm Loss: Suction Refrigerant Pressure - xy	Immediate	Latch	All	Continual loss of communication between the MP and the Functional ID has occurred for a 30 second period.	Remote
Comm Loss: Suction Valve Cktx	Normal	Latch	All	Continual loss of communication between the MP and the Functional ID has occurred for a 30 second period.	Remote



# Wiring

The table below provides a list of field wiring diagrams, electrical schematics, and connection diagrams for RTZA units. Wiring diagrams can be accessed via e-Library. A laminated wiring diagram booklet is also shipped with each unit. To determine the specific electrical characteristics of a particular chiller, refer to the nameplates mounted on the units.

Drawing		Description	
2311-6695	Sheet 1	Schematic – Wye-Delta Starter	Legend
	Sheet 2		Compressor – Ckt 1 (1A)
	Sheet 3		Compressor – Ckt 2 (2A)
	Sheet 4		Controls
	Sheet 5		Controls/LLID Bus
	Sheet 6		Controls/LLID Bus
2311-6696	Sheet 1	Unit Component Location	Diagram
2311-6697	Sheet 1	Control Panel Component Location	Diagram
	Sheet 2		Diagram
2311-6698	Sheet 1	Field Wiring	Diagram
	Sheet 2		Notes/Fuses
2311-6699	Sheet 1	Connection Diagram	Diagram
5719-4932	Sheets 1 – 3	Assembly Electrical Integration	Assembly Locations



## Reference Documents

Refer to the following documents:

- *Startup and Installation Checklist - Series R® Heat Pump Chiller - Model RTZA* (RLC-ADF011\*-EN)
- *Installation Completion Check Sheet and Request for Trane Service – Model RTZA* (RLC-ADF012\*-EN)
- *RTZA Disassembly Instructions* (RLC-SVN009\*-EN)
- *AdaptiView™ User Guide – Series R® Heat Pump Chiller – Model RTZA* (RLC-SVU010\*-EN)
- *Condenser Water Temperature Control – Model RTZA* (RLC-PRB061\*-EN)
- Chiller log sheet



# Chiller Log Sheet

Chiller Log Sheet				
Tab	Measurement	15 minutes	30 minutes	1 hour
<b>Main</b>				
	Chiller Mode			
	Evaporator Entering/Leaving Water Temperature			
	Condenser Entering/Leaving Water Temperature			
	Active Chiller Water Setpoint (°F)			
	Average Line Current (%RLA)			
	Active Demand Limit Setpoint (%RLA)			
	Software Type			
	Software Version			
<b>Reports</b>				
<b>EVAPORATOR</b>				
	Entering Water Temperature (°F)			
	Leaving Water Temperature (°F)			
	Saturated Refrigerant Temperature (°F)			
	Refrigerant Pressure (psia)			
	Approach Temperature (°F)			
	Water Flow Switch Status			
	EXV Position (%)			
	EXV Position Steps			
	Refrigerant Liquid Level (inch)			
<b>CONDENSER</b>				
	Entering Water Temperature (°F)			
	Leaving Water Temperature (°F)			
	Saturated Refrigerant Temperature (°F)			
	Refrigerant Pressure (psia)			
	Approach Temperature (°F)			
	Water Flow Switch Status			
	Head Pressure Control Command (%)			
<b>COMPRESSOR 1</b>				
	Starts			
	Run Time			
	System Refrigerant Differential Pressure (psid)			
	Oil Pressure (psia)			
	Refrigerant Discharge Temperature (°F)			
	Discharge Superheat (°F)			



# Chiller Log Sheet

Chiller Log Sheet				
Tab	Measurement	15 minutes	30 minutes	1 hour
	% RLA L1 L2 L3 (%)			
	Amps L1 L2 L3 (amps)			
	Volts AB BC CA			
COMPRESSOR 2				
	Starts			
	Run Time			
	System Refrigerant Differential Pressure (psid)			
	Oil Pressure (psia)			
	Refrigerant Discharge Temperature (°F)			
	Discharge Superheat (°F)			
	% RLA L1 L2 L3 (%)			
	Amps L1 L2 L3 (amps)			
	Volts AB BC CA			
Date:				
Technician:				
Owner:				

Chiller Settings		
Tab	Category	Setting
Settings		
CHILLER		
	Front Panel Water Setpoint (°F)	
	Front Panel Demand Limit Setpoint (°F)	
	Differential to Start (°F)	
	Differential to Stop (°F)	
	Setpoint Source	
FEATURE SETTINGS		
	Chilled Water Reset	
	Return Reset Ratio	
	Return Start Reset	
	Return Maximum Reset	
	Outdoor Reset Ratio	
	Outdoor Start Reset	
	Outdoor Maximum Reset	
MODE OVERRIDES		
	Evaporator Water Pump	
	Condenser Water Pump	
	Expansion Valve Control	
	Slide Valve Control	



# Chiller Log Sheet

Chiller Settings		
Tab	Category	Setting
	Service Pumpdown	
DISPLAY SETTINGS		
	Date Format	
	Date	
	Time Format	
	Time of Day	
	Keypad/Display Lockout	
	Display Units	
	Pressure Units	
	Language Selection	
Date:		
Technician:		
Owner:		





**Notes**

---



Trane - by Trane Technologies (NYSE: TT), a global innovator - creates comfortable, energy efficient indoor environments for commercial and residential applications. For more information, please visit [trane.com](http://trane.com) or [tranetechnologies.com](http://tranetechnologies.com).

Trane has a policy of continuous product and product data improvements and reserves the right to change design and specifications without notice. We are committed to using environmentally conscious print practices.