

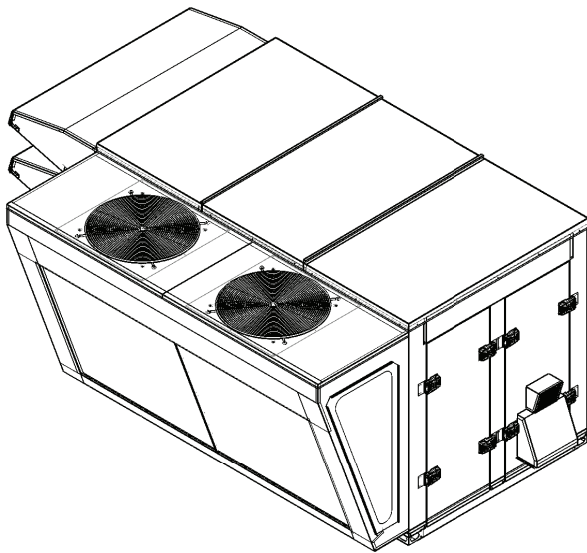

Installation, Operation, and Maintenance

Horizon™ Outdoor Air Unit

Indirect Fired Gas/Electric Heat/Air Source Heat Pump



Model : OADG and OANG

Important: Proper execution of the tasks outlined in this Installation, Operation, and Maintenance manual require and assume the technician has been certified as a start up technician for the Horizon Outdoor Air unit. This includes working knowledge of the Tracer TU program.

⚠ SAFETY WARNING

Only qualified personnel should install and service the equipment. The installation, starting up, and servicing of heating, ventilating, and air-conditioning equipment can be hazardous and requires specific knowledge and training. Improperly installed, adjusted or altered equipment by an unqualified person could result in death or serious injury. When working on the equipment, observe all precautions in the literature and on the tags, stickers, and labels that are attached to the equipment.

⚠ AVERTISSEMENT DE SÉCURITÉ

L'installation et l'entretien de cet équipement doivent être assurés exclusivement par du personnel qualifié. L'installation, la mise en service et l'entretien d'équipements de chauffage, de ventilation et de climatisation (CVC) présentent un danger et requièrent des connaissances et une formation spécifiques. Une installation, un réglage ou une modification inappropriés d'un équipement par une personne non qualifiée peut provoquer des blessures graves, voire la mort. Lors de toute intervention sur l'équipement, respectez les consignes de sécurité figurant dans la documentation, ainsi que sur les pictogrammes, autocollants et étiquettes apposés sur l'équipement..



Introduction

Read this manual thoroughly before operating or servicing this unit.

Warnings, Cautions, and Notices

Safety advisories appear throughout this manual as required. Your personal safety and the proper operation of this machine depend upon the strict observance of these precautions.

The three types of advisories are defined as follows:

⚠ WARNING Indicates a potentially hazardous situation which, if not avoided, could result in death or serious injury.

⚠ CAUTION Indicates a potentially hazardous situation which, if not avoided, could result in minor or moderate injury. It could also be used to alert against unsafe practices.

NOTICE Indicates a situation that could result in equipment or property-damage only accidents.

Important Environmental Concerns

Scientific research has shown that certain man-made chemicals can affect the earth's naturally occurring stratospheric ozone layer when released to the atmosphere. In particular, several of the identified chemicals that may affect the ozone layer are refrigerants that contain Chlorine, Fluorine and Carbon (CFCs) and those containing Hydrogen, Chlorine, Fluorine and Carbon (HCFCs). Not all refrigerants containing these compounds have the same potential impact to the environment. Trane advocates the responsible handling of all refrigerants-including industry replacements for CFCs such as HCFCs and HFCs.

Important Responsible Refrigerant Practices

Trane believes that responsible refrigerant practices are important to the environment, our customers, and the air conditioning industry. All technicians who handle refrigerants must be certified. The Federal Clean Air Act (Section 608) sets forth the requirements for handling, reclaiming, recovering and recycling of certain refrigerants and the equipment that is used in these service procedures. In addition, some states or municipalities may have additional requirements that must also be adhered to for responsible management of refrigerants. Know the applicable laws and follow them.

⚠ WARNING

Proper Field Wiring and Grounding Required!

Failure to follow code could result in death or serious injury. All field wiring **MUST** be performed by qualified personnel. Improperly installed and grounded field wiring poses **FIRE** and **ELECTROCUTION** hazards. To avoid these hazards, you **MUST** follow requirements for field wiring installation and grounding as described in **NEC** and your local/state electrical codes.

⚠ WARNING

Câblage sur site et mise à la terre corrects nécessaires!

Le non-respect de la réglementation peut entraîner des blessures graves, voire mortelles. Il est **IMPÉRATIF** de confier l'ensemble du câblage sur site à un électricien qualifié. Un câblage sur site mal installé ou mal mis à la terre constitue des risques **D'INCENDIE** et **D'ÉLECTROCUTION**. Pour éviter ces risques, il est **IMPÉRATIF** de respecter les obligations en matière de pose de câblage sur site et de mise à la terre tel que stipulé dans les règles du **NEC** et dans les réglementations électriques locales/nationales..

⚠ WARNING**Personal Protective Equipment (PPE) Required!**

Failure to wear proper PPE for the job being undertaken could result in death or serious injury. Technicians, in order to protect themselves from potential electrical, mechanical, and chemical hazards, **MUST** follow precautions in this manual and on the tags, stickers, and labels, as well as the instructions below:

- Before installing/servicing this unit, technicians **MUST** put on all PPE required for the work being undertaken (Examples: cut resistant gloves/sleeves, butyl gloves, safety glasses, hard hat/bump cap, fall protection, electrical PPE and arc flash clothing). **ALWAYS** refer to appropriate Safety Data Sheets (SDS) and OSHA guidelines for proper PPE.
- When working with or around hazardous chemicals, **ALWAYS** refer to the appropriate SDS and OSHA/GHS (Global Harmonized System of Classification and Labeling of Chemicals) guidelines for information on allowable personal exposure levels, proper respiratory protection and handling instructions.
- If there is a risk of energized electrical contact, arc, or flash, technicians **MUST** put on all PPE in accordance with OSHA, NFPA 70E, or other country-specific requirements for arc flash protection, **PRIOR** to servicing the unit. **NEVER PERFORM ANY SWITCHING, DISCONNECTING, OR VOLTAGE TESTING WITHOUT PROPER ELECTRICAL PPE AND ARC FLASH CLOTHING. ENSURE ELECTRICAL METERS AND EQUIPMENT ARE PROPERLY RATED FOR INTENDED VOLTAGE.**

⚠ AVERTISSEMENT**Équipements de protection individuelle (EPI) obligatoires!**

En cas d'équipement de protection individuelle inadapté au travail entrepris, les techniciens s'exposent à des risques de blessures graves voire mortelles. Afin de se prémunir d'éventuels risques électriques, mécaniques et chimiques, les techniciens **DOIVENT** respecter les consignes préconisées dans le présent manuel, sur les étiquettes et les autocollants, ainsi que les instructions suivantes:

- Avant d'installer/réparer cette unité, les techniciens doivent **IMPÉRATIVEMENT** porter tout l'équipement de protection individuelle (EPI) recommandé pour le travail entrepris (exemples : gants/manchons résistants aux coupures, gants en caoutchouc butyl, lunettes de protection, casque de chantier/antichoc, protection contre les chutes, EPI pour travaux électriques et vêtements de protection contre les arcs électriques). Consulter **SYSTÉMATIQUEMENT** les fiches de données de sécurité et les directives de l'OSHA pour connaître la liste des EPI adaptés.
- Lors d'une intervention avec ou à proximité de produits chimiques dangereux, consulter **SYSTÉMATIQUEMENT** les fiches de données de sécurité appropriées et les directives de l'OSHA/du SGH (système général harmonisé de classification et d'étiquetage des produits chimiques) afin d'obtenir des renseignements sur les niveaux admissibles d'exposition personnelle, la protection respiratoire adaptée et les recommandations de manipulation.
- En cas de risque d'éclair, d'arc électrique ou de contact électrique avec un équipement électrique sous tension, et **AVANT** de réparer l'unité, les techniciens doivent **IMPÉRATIVEMENT** porter tout l'équipement de protection individuelle (EPI) conformément à l'OSHA, à la norme NFPA 70E ou à toute autre exigence propre au pays pour la protection contre les arcs électriques. **NE JAMAIS COMMUTER, DÉBRANCHER ou EFFECTUER DE TEST DE TENSION SANS PORTER UN EPI POUR TRAVAUX ÉLECTRIQUES OU UN VÊTEMENT DE PROTECTION APPROPRIÉ CONTRE LES ARCS ÉLECTRIQUES. IL CONVIENT DE S'ASSURER QUE LES COMPTEURS ET ÉQUIPEMENTS ÉLECTRIQUES CORRESPONDENT À LA TENSION NOMINALE PRÉVUE.**

⚠ WARNING**Follow EHS Policies!**

Failure to follow instructions below could result in death or serious injury.

- All Trane personnel must follow the company's Environmental, Health and Safety (EHS) policies when performing work such as hot work, electrical, fall protection, lockout/tagout, refrigerant handling, etc. Where local regulations are more stringent than these policies, those regulations supersede these policies.
- Non-Trane personnel should always follow local regulations.

⚠ AVERTISSEMENT**Respecter les politiques EHS !**

Le non-respect des consignes suivantes peut être à l'origine de blessures graves, voire mortelles.

- Tous les membres du personnel externes à l'entreprise sont tenus de respecter les règles établies par l'entreprise en matière d'environnement, de santé et de sécurité (EHS) lors d'une intervention, notamment en cas de travail à chaud, risque de choc électrique et de chute, procédures de verrouillage / déclassement, manipulation de fluide frigorigène, etc. Si les réglementations locales sont plus strictes que les règles imposées par le groupe, elles deviennent prioritaires.
- Le personnel extérieur à l'entreprise est, quant à lui, systématiquement tenu d'observer les réglementations en vigueur à l'échelle locale.

⚠ WARNING**Refrigerant under High Pressure!**

Failure to follow instructions below could result in an explosion which could result in death or serious injury or equipment damage. System contains oil and refrigerant under high pressure. Recover refrigerant to relieve pressure before opening the system. See unit nameplate for refrigerant type. Do not use non-approved refrigerants, refrigerant substitutes, or refrigerant additives.

⚠ AVERTISSEMENT**Fluide frigorigène sous haute pression!**

Tout manquement aux instructions indiquées ci-dessous peut provoquer une explosion pouvant causer des blessures graves voire mortelles ou des dommages matériels. Le système contient de l'huile et du fluide frigorigène sous haute pression. Avant d'ouvrir le circuit, récupérez le fluide frigorigène pour éliminer toute pression dans le circuit. Consultez la plaque constructeur de l'unité pour connaître le type de fluide frigorigène employé. Utilisez uniquement des fluides frigorigènes, substitués et additifs agréés.

⚠ WARNING**Hazard of Explosion and Deadly Gases!**

Failure to follow all proper safe refrigerant handling practices could result in death or serious injury. Never solder, braze or weld on refrigerant lines or any unit components that are above atmospheric pressure or where refrigerant may be present. Always remove refrigerant by following the guidelines established by the EPA Federal Clean Air Act or other state or local codes as appropriate. After refrigerant removal, use dry nitrogen to bring system back to atmospheric pressure before opening system for repairs. Mixtures of refrigerants and air under pressure may become combustible in the presence of an ignition source leading to an explosion. Excessive heat from soldering, brazing or welding with refrigerant vapors present can form highly toxic gases and extremely corrosive acids.

⚠ AVERTISSEMENT**Risque d'explosion et gaz mortels!**

Le non-respect de toutes les consignes de manipulation des fluides frigorigènes peut entraîner la mort ou des blessures graves.

N'effectuez en aucune circonstance des opérations de brasage ou de soudage sur des conduites de fluide frigorigène ou des composants de l'unité sous pression ou pouvant contenir du fluide frigorigène. Récupérez systématiquement le fluide frigorigène en respectant les directives de la loi américaine sur la propreté de l'air (Agence fédérale pour l'environnement) ou toute autre réglementation nationale ou locale en vigueur. Après la récupération du fluide frigorigène, utilisez de l'azote déshydraté pour ramener le système à la pression atmosphérique avant de l'ouvrir pour procéder aux réparations. Les mélanges de fluide frigorigène et d'air sous pression peuvent devenir combustibles en présence d'une source d'inflammation et provoquer une explosion. La chaleur excessive découlant de travaux de soudage ou de brasage associée à la présence de vapeurs de fluide frigorigène peut entraîner la formation de gaz hautement toxiques et d'acides extrêmement corrosifs.

⚠ WARNING**Hazard of Explosion and Deadly Gases!**

Failure to follow instructions could result in death or serious injury.

If you smell gas:

1. Open windows.
2. Don't touch electrical switches.
3. Extinguish any open flame.
4. Immediately call your gas supplier.

⚠ AVERTISSEMENT**Risque d'explosion et gaz mortels!**

Le non-respect de toutes les consignes de sécurité ci-dessous peut entraîner la mort ou des blessures graves.

Si vous sentez une odeur de gaz:

1. Ouvrez les fenêtres.
2. Ne touchez à aucun interrupteur.
3. Éteignez toute flamme nue.
4. Avertissez immédiatement votre fournisseur de gaz.

⚠ WARNING**Hazardous Service Procedures!**

Improper installation, adjustment, alteration, service or maintenance can cause property damage, injury or death. Read the installation, operating and maintenance instructions thoroughly before installing or servicing this equipment.

⚠ AVERTISSEMENT**Procédures d'entretien dangereuses!**

Une installation, un réglage, une modification, une réparation ou un entretien incorrect peut entraîner des dommages matériels, des blessures ou la mort. Lisez attentivement les instructions d'installation, de fonctionnement et d'entretien avant de procéder à l'installation ou à l'entretien de cet équipement.

⚠ WARNING**Hazard of Explosion and Deadly Gases!**

Failure to follow instructions could result in death or serious injury.

The use and storage of gasoline or other flammable vapors and liquids in open containers in the vicinity of this appliance is hazardous.

⚠ AVERTISSEMENT**Risque d'explosion et gaz mortels!**

Le non-respect de toutes les consignes de sécurité ci-dessous peut entraîner la mort ou des blessures graves.

Il est dangereux d'utiliser ou d'entreposer de l'essence ou autres liquides ou vapeurs inflammables dans des récipients ouverts à proximité de cet appareil.

Copyright

This document and the information in it are the property of Trane, and may not be used or reproduced in whole or in part without written permission. Trane reserves the right to revise this publication at any time, and to make changes to its content without obligation to notify any person of such revision or change.

Trademarks

All trademarks referenced in this document are the trademarks of their respective owners.

Revision History

- Added Supply and Exhaust Piezo Fan Rings, ERV, Hot Water Coils, Suction Pressure Monitoring, and Head Pressure Control sections to the General Information chapter.
- Updated Ductwork section in the Installation chapter.
- Updated the DC Conductors OAUITS graphic in the Installation chapter.
- Added the Chart of analog and binary input/output table to the System Configuration and Pre-Start chapter.
- Updated the Pre-Startup procedure in the System Configuration and Pre-Start chapter.
- Removed the Microchannel (MCHE) Coils section from the Maintenance chapter.
- Added the Diagnostics values chart table to the Alarms and Troubleshooting chapter.
- Added Horizon UC600 attention start up for Service Technician and Startup Forms sections.



Table of Contents

Model Number Descriptions	9	Curb Dimensions	17
Horizon Outdoor Air Unit	9	Dimensional Data	18
Model: OADG and OANG	9	OAN Units	21
General Information	12	Unit Clearances	21
Overview of Manual	12	Curb Dimensions	21
Model Number Description	12	22
Unit Nameplate	12	Unit Weight and Rigging	25
Compressor Nameplate	12	Unit Weight	25
Unit Description	12	Installation	29
Indoor Fan Failure Input	12	Ductwork	29
Low Pressure Control ReliaTel Control	12	General Unit Requirements	30
Refrigerant Circuits	12	Main Electrical Power Requirements	30
High Pressure Control ReliaTel Control	12	Condensate Drain Configuration	30
Space Temperature / RH Sensor (Optional)	13	Hot Water Connection Size and Location	31
High Temperature Sensor	13	Chilled Water Connection Size and Location	31
Outdoor Air Temperature and Relative Humidity Sensor	13	Filter Installation	32
Control Input (Occupied / Unoccupied)	13	Field Installed Power Wiring	32
Hot Gas Reheat	13	Main Unit Power	34
100 Percent Outdoor Air Hood with Damper and Filters	13	Standard Wiring	34
Modulating Indirect Fired Gas Burner	13	Electrical Phasing (Three-Phase Motors)	35
Through the Base Electrical with Disconnect Switch	13	Compressor Crankcase Heaters	36
Hinged Access Doors	13	Main Unit Display and ReliaTel Controls	36
Electric Heat	13	Field-Installed Control Wiring	36
Supply and Exhaust Piezo Fan Rings	13	Control Power Transformer	37
ERV	13	Controls Using 24 Vac	37
ERV	13	Controls Using DC Analog Input/Output (Standard Low Voltage Multiconductor Wire)	37
Hot Water Coils	14	DC Conductors	38
Suction Pressure Monitoring	14	Factory-Provided Sensors	38
Head Pressure Control	14	Pre-Start Check List	39
First Aid Measures	14	System Configuration and Pre-Start	40
Storage	14	Pre-Start Up	50
Unit Clearances	15	Start Up	50
Unit Clearances, Curb Dimensions, and Dimensional Data	16	Cooling Start Up	50
OAD Units	16	Startup	52
Unit Clearances	16	Indirect Fired Gas Heating Startup	52
		Startup Procedure	53

Safety Controls	57	VAV	79
..... Maintenance	58	Supply Fan Tracking for Exhaust Fan (Field Enabled)	79
Monthly Maintenance	58	Hot Water Reheat	79
Filters	58	Expanded Fallback Control	79
Supply/Return Air Smoke Detector Maintenance	58	General	80
Cooling Season	58	Program-Controlled Setpoints	80
Heating Season	58	Space Control and Single Zone VAV Control	80
Condenser Coil Cleaning	58	Discharge Air Control and Multi-Zone VAV Control	80
General Data	61	Occupied Control	80
Alarms and Troubleshooting	68	Starting Sequence	80
Microprocessor Control	68	Supply Fan Sequence	80
System Alarms	68	Economizer Mode	81
Sensor Failure Alarm Display	68	Ventilation Mode	81
RTRM Failure Modes	72	Discharge Air Control	81
Condenser Fan VFD Troubleshooting ..	72	Space Control	81
Appendix	73	Single Zone VAV Control	81
OAU Filter Guide	73	Primary Heating Mode	81
Attention Startup or Service Technician ..	78	Discharge Air Control	81
Horizon UC600 v11.0 Released	78	Multi-Zone VAV Control	81
Documents Included in This Packet: ...	78	Space Control or Single Zone VAV Control, with Energy Recovery Wheel or has Mixed Air	81
Unchanged from Previous Versions: ...	78	Space Control or Single Zone VAV Control with No Energy Recovery Wheel and 100% Outdoor Air	82
Summary of Improvements	78	Gas Heat Ignition Failure	82
Suction Pressure Monitoring	78	Heat Pump Heating Mode	82
Compressor Run Status and Diagnostics	78	Water Source Heat Pump	82
Updated Point Names to Match Tracer SC	78	Air Source Heat Pump – Demand Defrost Control	82
Evaporator Leaving Temperature Setpoint Reset	78	Cooling Mode	82
Minimum Supply Air Flow Setpoints ...	78	Discharge Air Control	82
Single Zone VAV Mod. Air Flow - Heating Mode	78	Multi-Zone VAV Control	82
Gas Heater Staging Off at Minimum Capacity	78	Space Control or Single Zone VAV Control with No Energy Recovery Wheel and 100% Outdoor Air	83
Reduced Hot Gas Reheat Purge Mode ..	78	Compressor Low Ambient Lockout ...	83
Unit Shutdown Due to Condensate Overflow	78	Evaporator Frost Protection	83
Liquid Line Pressure Setpoint Reset	78	Dehumidification Mode	83
Modulating ERV Exhaust and Outdoor Air Bypass	78	Discharge Air Control	83
Space Control or Single Zone VAV and OA Setpoints	79		
Discharge Air Temp. Reset for Single Zone			



Table of Contents

Multi-Zone VAV Control	83	Pre-Startup Checklist	88
Space Control with Energy Recovery Wheel or has Mixed Air	83	Voltages	89
Space Control with No Energy Recovery Wheel and 100% Outdoor Air	83	Motor Data	90
Hot Gas Reheat Purge	83	Compressor Data	90
Supplemental Electric Reheat (Not Included in Standard Operation)	83	Actuators	90
Supplemental Hot Water Reheat	84	Test Procedures	91
Hot Water Reheat (No Hot Gas Reheat In- stalled)	84	Furnace Data	92
Exhaust Fan Operation	84	Gas Pressure Settings	92
With Isolation Exhaust Fan Damper(s) . .	84	Electric Heat Startup	92
Without Isolation Exhaust Fan Dampers	84	Heater Data	92
With Modulating OA/RA Dampers	84	Program Control Type (MV-13)	93
ECM Exhaust with 2-Position OA Damper	84	Description	93
VFD Exhaust with 2-Position OA Damper	84	Commissioning	93
Energy Recovery Wheel Operation (ERV)	84		
Energy Wheel Without VFD	84		
Energy Wheel With VFD	84		
Additional Features	84		
Electric Pre-Heat	84		
Space Thumbwheel Input	84		
Split Exhaust and Return Air Path	84		
Outdoor Airflow Monitoring	85		
Optional Field Enabled Features	85		
Demand Control CO2 Ventilation	85		
Exhaust Fan Tracking	85		
Static Pressure Control for Exhaust Fan .	85		
Unoccupied Operation	85		
Starting Sequence	85		
With Return Air Damper Installed	85		
No Return Air Damper Installed	85		
Unoccupied Heating Mode	85		
Unoccupied Dehumid Mode	85		
Unoccupied Cooling Mode	85		
Diagnostics	85		
Sensor Source Failures	87		
Economizer Fault Detection and Diagnostics	87		
Trane® Horizon™ DOAS	88		



Model Number Descriptions

Horizon Outdoor Air Unit

Model: OADG and OANG

Digit 1, 2 – Unit Type

OA = Outdoor Air

Digit 3 – Cabinet Size

D = 1250–8000 cfm
N = 5000–25000 cfm

Digit 4 – Major Design Sequence

G = Revision 6

Digit 5, 6, 7 – Normal Gross Cooling Capacity (MBh)

000 = No DX Cooling
010 = 10 Tons High Efficiency
012 = 12 Tons High Efficiency
015 = 15 Tons High Efficiency
017 = 17 Tons High Efficiency
020 = 20 Tons High Efficiency
040 = 40 Tons High Efficiency
045 = 45 Tons High Efficiency
050 = 50 Tons High Efficiency
055 = 55 Tons High Efficiency
060 = 60 Tons High Efficiency
065 = 65 Tons High Efficiency
070 = 70 Tons High Efficiency
075 = 75 Tons High Efficiency
080 = 80 Tons High Efficiency

Digit 8 – Airflow Configuration

A = Vertical Discharge/No Return
B = Horizontal Discharge/No Return
C = Vertical Discharge/Vertical Return
D = Vertical Discharge/Horizontal Return/Exhaust
E = Horizontal Discharge/Vertical Return/Exhaust
F = Horizontal Discharge/Horizontal Return/Exhaust
G = Vertical Discharge/Vertical Return/Vertical Exhaust
H = Vertical Discharge/Vertical Return/Horizontal Exhaust
J = Vertical Discharge/Horizontal Return/Vertical Exhaust
K = Vertical Discharge/Horizontal Return/Horizontal Exhaust
L = Horizontal Discharge/Vertical Return/Vertical Exhaust
M = Horizontal Discharge/Vertical Return/Horizontal Exhaust
N = Horizontal Discharge/Horizontal Return/Vertical Exhaust
P = Horizontal Discharge/Horizontal Return/Horizontal Exhaust

Digit 9 – Voltage Selection

1 = 208/60/3
2 = 230–240/60/3
3 = 460/60/3
4 = 575/60/3

Digit 10 – Not Used

Digit 11 – Indoor Coil Type

0 = No Indoor Coil
C = DX 4-Row
D = DX 6-Row
F = Glycol/Chilled Water Coil—4-Row
G = Glycol/Chilled Water Coil—6-Row
H = Glycol/Chilled Water Coil with Cooney Freeze Block Technology—4-Row
J = Glycol/Chilled Water Coil with Cooney Freeze Block Technology—6-Row

Digit 12 – Reheat

0 = No Reheat
A = Fin and Tube Modulating HGRH

Digit 13 – Compressor

0 = No Compressor
A = Scroll Compressors
B = Digital Scroll—1st Circuit Only
C = Digital Scroll—1st Circuit and 2nd Circuit

Digit 14 – Outdoor Coil

0 = No Condenser
1 = Air-cooled Fin and Tube
3 = Water-cooled Copper/Nickel
4 = Water-cooled Copper/Steel
5 = ASHP Fin and Tube
7 = WSHP Copper/Nickel
8 = WSHP Copper/Steel

Digit 15 – Refrigerant Capacity Control

0 = No RCC Valve
1 = RCC Valve on 1st Circuit

Digit 16 – Heat Type—Primary

0 = No Heat
A = Indirect Fired NG (IF)—Standard Efficiency (80%)
B = Indirect Fired NG (IF)—High Efficiency (82%)
D = Indirect Fired LP (IF)—Standard Efficiency (80%)
E = Indirect Fired LP (IF)—High Efficiency (82%)
G = Hot Water
H = Electric—Staged
J = Electric—SCR Modulating

Digit 17 – Heat Capacity—Primary

	IF	ELEC	HOT WATER
0	= No Heat		
A	= 50 MBh	5 kW	1 Row/10 FPI
B	= 75 MBh	10 kW	1 Row/12 FPI
C	= 100 MBh	15 kW	1 Row/14 FPI
D	= 125 MBh	20 kW	2 Row/10 FPI
E	= 150 MBh	24 kW	2 Row/12 FPI
F	= 200 MBh	28 kW	2 Row/14 FPI
G	= 250 MBh	32 kW	3 Row/10 FPI
H	= 300 MBh	40 kW	3 Row/12 FPI
J	= 350 MBh	48 kW	3 Row/14 FPI
K	= 400 MBh	60 kW	
L	= 500 MBh	68 kW	
M	= 500 MBh (Dual 250)	79 kW	
N	= 600 MBh	99 kW	
P	= 600 MBh (Dual 300)	111 kW	
R	= 800 MBh	119 kW	
S	= 800 MBh (Dual 400)	139 kW	
T	= 1000 MBh	159 kW	
U	= 1000 MBh (Dual 500)	179 kW	
V	= 1200 MBh	199 kW	
W	=	215 kW	
Y	=	230 kW	
Z	=	250 kW	

Digit 18 – Heat Type—Secondary

0 = No Secondary Heat
4 = Electric—Staged

Digit 19 – Heat Capacity—Secondary



Model Number Descriptions

- 0 = No Secondary Heat
- A = 5 kW
- B = 10 kW
- C = 15 kW
- D = 20 kW
- E = 24 kW
- F = 28 kW
- G = 32 kW
- H = 40 kW
- J = 48 kW
- K = 60 kW
- L = 68 kW
- M = 79 kW
- N = 99 kW
- P = 111 kW
- R = 119 kW

Digit 20 – Not Used

Digit 21 – Supply Fan Motor

- A = 1 hp–1800 rpm
- B = 1 hp–3600 rpm
- C = 1.5 hp–1800 rpm
- D = 1.5 hp–3600 rpm
- E = 2 hp–1800 rpm
- F = 2 hp–3600 rpm
- G = 3 hp–1800 rpm
- H = 3 hp–3600 rpm
- J = 5 hp–1800 rpm
- K = 5 hp–3600 rpm
- L = 7.5 hp–1800 rpm
- M = 7.5 hp–3600 rpm
- N = 10 hp–1800 rpm
- P = 10 hp–3600 rpm
- R = 15 hp–1800 rpm
- S = 15 hp–3600 rpm
- T = 20 hp–1800 rpm
- U = 20 hp–3600 rpm

Digit 22 – Supply Fan Motor

Type

- 1 = Direct Drive w/VFD
- 2 = Direct Drive (VFD by Others)
- 3 = Direct Drive w/Shaft Grounding Ring w/VFD

Digit 23, 24 – Supply Fan Wheel Diameter

- AA = 12-in. Wheel
- AB = 12-in.—60% Width Wheel
- AC = 14-in. Wheel
- AD = 14-in.—60% Width Wheel
- AE = 16-in. Wheel
- AF = 16-in.—60% Width Wheel
- AG = 18-in. Wheel
- AH = 18-in.—60% Width Wheel
- AJ = 20-in. Wheel
- AK = 20-in.—60% Width Wheel
- AL = 22-in. Wheel
- AM = 22-in.—60% Width Wheel
- AN = 25-in. Wheel
- AP = 25-in.—60% Width Wheel
- BG = Dual 18-in. Wheel
- BH = Dual 18-in.—60% Width Wheel
- BJ = Dual 20-in. Wheel
- BK = Dual 20-in.—60% Width Wheel
- BL = Dual 22-in. Wheel

- BM = Dual 22-in.—60% Width Wheel
- BN = Dual 25-in. Wheel
- BP = Dual 25-in.—60% Width Wheel

Digit 25 – Exhaust Fan Motor

- 0 = No Powered Exhaust
- A = 1 hp–1800 rpm
- B = 1 hp–3600 rpm
- C = 1.5 hp–1800 rpm
- D = 1.5 hp–3600 rpm
- E = 2 hp–1800 rpm
- F = 2 hp–3600 rpm
- G = 3 hp–1800 rpm
- H = 3 hp–3600 rpm
- J = 5 hp–1800 rpm
- K = 5 hp–3600 rpm
- L = 7.5 hp–1800 rpm
- M = 7.5 hp–3600 rpm
- N = 10 hp–1800 rpm
- P = 10 hp–3600 rpm
- R = 15 hp–1800 rpm
- S = 15 hp–3600 rpm
- T = 20 hp–1800 rpm
- U = 20 hp–3600 rpm

Digit 26 – Exhaust Fan Motor Type

- 0 = No Powered Exhaust
- 1 = Direct Drive w/VFD
- 2 = Direct Drive (VFD by Others)
- 3 = Direct Drive w/Shaft Grounding Ring w/VFD

Digit 27, 28 – Exhaust Fan Wheel Diameter

- 00 = No Powered Exhaust
- AA = 12-in. Wheel
- AB = 12-in.—60% Width Wheel
- AC = 14-in. Wheel
- AD = 14-in.—60% Width Wheel
- AE = 16-in. Wheel
- AF = 16-in.—60% Width Wheel
- AG = 18-in. Wheel
- AH = 18-in.—60% Width Wheel
- AJ = 20-in. Wheel
- AK = 20-in.—60% Width Wheel
- AL = 22-in. Wheel
- AM = 22-in.—60% Width Wheel
- AN = 25-in. Wheel
- AP = 25-in.—60% Width Wheel
- BG = Dual 18-in. Wheel
- BH = Dual 18-in.—60% Width Wheel
- BJ = Dual 20-in. Wheel
- BK = Dual 20-in.—60% Width Wheel
- BL = Dual 22-in. Wheel
- BM = Dual 22-in.—60% Width Wheel
- BN = Dual 25-in. Wheel
- BP = Dual 25-in.—60% Width Wheel

Digit 29 – Powered Exhaust Fan Motor (PFM) and Exhaust Dampers

- 0 = No Piezo Ring
- 1 = Supply Fan Piezo Ring
- 2 = Exhaust Fan Piezo Ring
- 3 = Supply Fan Piezo Ring and Exhaust Fan Piezo Ring

Digit 30 – Not Used

Digit 31 – Unit Controls

- 0 = No Controls
- 1 = Space Control

- 2 = Discharge Air Control
- 3 = Multi-Zone VAV
- 4 = Single-Zone VAV

Digit 32 – Building Interface

- 0 = No Controls
- 1 = BACnet®
- 3 = LON

Digit 33 – Filter Options

- 0 = No Filters
- A = MERV-8, 30%
- B = MERV-13, 80%
- C = MERV-14, 95%
- D = MERV-8 30%, MERV-13 80%
- E = MERV-8 30%, MERV-14 95%

Model Number Descriptions

Digit 34 — Energy Recovery

- 0 = No Energy Recovery
- 1 = ERV—Composite Construction with Bypass for Frost Protection
- 2 = ERV—Composite Construction with Frost Protection w/VFD
- 3 = ERV—Aluminum Construction with Bypass for Frost Protection
- 4 = ERV—Aluminum Construction with Frost Protection w/VFD

Digit 35 — Energy Recover Option, Purge

- 0 = No Purge
- 1 = Purge

Digit 36 — Energy Recover Wheel Size

- 0 = No ERV
- A = 3014
- B = 3622
- C = 4136
- D = 4634
- E = 5262
- F = 5856
- G = 6488
- H = 6876
- J = 74122
- K = 81146
- L = 86170
- M = 92180

Digit 37 — Energy Recovery Option, Rotation Sensor

- 0 = No Rotation Sensor
- 1 = Rotation Sensor

Digit 38 — Damper Options

- 1 = 100% OA 2-Position Damper
- 2 = 100% OA 2-Position Damper w/RA 2-Position Damper
- 3 = Modulating OA and RA Dampers w/Economizer
- 4 = Modulating OA Damper

Digit 39 — Exhaust Dampers

- 0 = No Exhaust Dampers
- A = Gravity Dampers
- B = Isolation Dampers
- C = Barometric Relief Dampers

Digit 40 — Not Used

Digit 41 — Electrical Options

- 0 = Terminal Block—No Factory Installed Disconnect
- A = Non-Fused Disconnect
- B = Fused Disconnect Switch
- C = 65 SCCR Electrical Rating w/Non-Fused Disconnect
- D = 65 SCCR Electrical Rating w/Fused Disconnect
- E = 65 KAIC Electrical Rating w/Non-Fused Disconnect
- F = 65 KAIC Electrical Rating w/Fused Disconnect
- G = Dual Point Power
- H = Dual Point Power 65 KAIC
- J = Dual Point Power 65 SCCR

Digit 42 — Corrosive Environment Package

- 0 = No Corrosive Package
- A = Eco Coated Coils
- B = S/S Interior
- C = S/S Coil Casing
- D = S/S Coil Casing with Eco Coated Coils
- E = S/S Interior, Eco Coated Coils
- F = Corrosion Resistant Package

Digit 43 — Outdoor Air Monitoring

- 0 = No Outdoor Air Monitoring
- 1 = Airflow Probes

Digit 44 — Condenser Fan Options

- 0 = No Condenser Fans
- A = Standard Condenser Fan
- B = Passive Head Pressure Control
- C = Active Head Pressure Control
- D = ECM Condenser Fans with Active Head Pressure Control
- E = ECM Condenser Fans with Active Head Pressure Control for Sound Attenuation

Digit 45 — Compressor Sound Blankets and Sound Attenuation

- 0 = No Sound Attenuation Package
- A = Compressor Sound Blankets
- B = Compressor Sound Blankets with Sound Attenuation Condenser Fans

Digit 46 — Smoke Detector

- 0 = No Smoke Detector
- 1 = Supply Smoke Detector
- 2 = Return Smoke Detector
- 3 = Supply and Return Smoke Detector

Digit 47 — Hailguards

- 0 = No Hailguards
- A = Hailguards

Digit 48 — Service Lights

- 0 = No Service Lights
- A = Supply Fan Section Service Light
- B = Exhaust Fan Section Service Light
- C = Supply and Exhaust Fan Section Service Light

Digit 49 — UV Lights

- 0 = No UV Lights
- 1 = UV Lights

Digit 50 — Not Used

Digit 51 — Unit Installation Location

- A = Outdoor
- B = Indoor

Digit 52 — Convenience Outlet

- 0 = No Convenience Outlet
- A = Convenience Outlet

Digit 53 — Controls Display

- 0 = No Display
- 1 = TD7 Factory Installed
- 2 = TD7 Remote Mounted

Digit 54 — Cooling Controls

- 0 = No ReliaTel™
- A = ReliaTel™
- B = ReliaTel™ with BCIR Card

Digit 55 — Face and Bypass on Indoor Coil

- 0 = No Face and Bypass

Digit 56 — Thermostat

- 0 = No Thermostat
- 1 = Thumbwheel Thermostat

Digit 57 — Altitude

- 0 = Sea Level to 1000 Feet
- 1 = 1001 to 2000 Feet
- 2 = 2001 to 3000 Feet
- 3 = 3001 to 4000 Feet
- 4 = 4001 to 5000 Feet
- 5 = 5001 to 6000 Feet
- 6 = 6001 to 7000 Feet
- 7 = Above 7000 Feet

Digit 58 — Condensate Overflow Switch

- 0 = No Condensate Overflow Switch
- A = Condensate Overflow Switch

Digit 59 — Frostat

- 0 = No Frostat™
- A = Frostat™ Installed

Digit 60 — Not Used

Digit 61 — Outdoor Coil Fluid Type

- 0 = None
- 1 = Water
- 2 = Ethylene Glycol
- 3 = Propylene Glycol
- 4 = Methanol
- 5 = Other

Digit 62 — Minimum Damper Leakage

- 0 = Standard
- 1 = Class 1A

Digit 63, 64, 65, 66, 67, 68, 69 — Reserved for Future Use



General Information

Overview of Manual

Note: One copy of this document ships inside the control panel of each unit and is customer property. It must be retained by the unit's maintenance personnel.

This booklet describes proper installation, operation, and maintenance procedures for air cooled systems. By carefully reviewing the information within this manual and following the instructions, the risk of improper operation and/or component damage will be minimized.

It is important that periodic maintenance be performed to help assure trouble free operation. A maintenance schedule is provided at the end of this manual. Should equipment failure occur, contact a qualified service organization with qualified, experienced HVAC technicians to properly diagnose and repair this equipment.

Model Number Description

All products are identified by a multiple-character model number that precisely identifies a particular type of unit. An explanation of the alphanumeric identification code is provided (refer to "Model Number Descriptions," p. 9). Its use will enable the owner/operator, installing contractors, and service engineers to define the operation, specific components, and other options for any specific unit.

When ordering replacement parts or requesting service, be sure to refer to the specific model number and serial number printed on the unit nameplate.

Unit Nameplate

A Mylar® unit nameplate is located on the unit's corner support next to the control box. It includes the unit model number, serial number, electrical characteristics, refrigerant charge, as well as other pertinent unit data.

Compressor Nameplate

The nameplate for the compressors are located on the side of the compressor.

Unit Description

Before shipment, each unit is leak tested, dehydrated, charged with refrigerant and compressor oil, and run tested for proper control operation.

The condenser coils are aluminum fin, mechanically bonded to copper tubing.

Direct-drive, vertical discharge condenser fans are provided with built-in thermal overload protection.

The Outdoor Air Unit Main Unit Display and ReliaTel™ Control Module (RTRM) are microelectronic control systems. The acronym RTRM is extensively throughout this document when referring to the control system network.

The Main Unit Display and the RTRM are mounted in the Main Control Panel. The Main Unit Display and RTRM

receive information from sensors and customer binary contacts to satisfy the applicable request for ventilation, cooling, dehumidification and heating.

Indoor Fan Failure Input

The Indoor Fan Failure Switch (IFFS) is connected to verify indoor fan operation.

When there is a call for the indoor fan to be energized, the differential pressure switch, connected to the Main Unit Display, must prove airflow within 30 seconds or the Main Unit Display will shut off all mechanical operations, lock the system out and send a diagnostic alarm to the Unit Display. The system will remain locked out until a reset is initiated through the MCM via the Alarm Reset Function on the Unit Display.

Low Pressure Control ReliaTel Control

This input incorporates the compressor low pressure control (CLP 1/2) of each refrigeration circuit and can be activated by opening a field supplied contact installed on the OAUTS.

If this circuit is open before the compressor is started, the ReliaTel™ control will not allow the affected compressor to operate. Anytime this circuit is opened for 1 continuous second during compressor operation, the compressor for that circuit is immediately turned "Off." The compressor will not be allowed to restart for a minimum of 3 minutes should the contacts close.

If four consecutive open conditions occur during the first three minutes of operation, the compressor for that circuit will be locked out, and a manual reset will be required to restart the compressor.

Refrigerant Circuits

For 10–20 ton units, one refrigerant circuit shall incorporate a standard 4- or 6-row coil. All circuits shall have thermal expansion valves (TXVs), service pressure ports, and refrigerant line filter driers as standard. An area will be provided for replacement suction line driers. Refrigerant circuit one (1st Stage) is equipped with a factory installed and preset refrigerant capacity control (RCC) to prevent evaporator coil temperatures below approximately 38°F (114 lb suction). The refrigerant capacity device is not installed when the unit is equipped with a digital scroll or variable speed compressor.

High Pressure Control ReliaTel Control

The compressor high pressure controls (CHP 1/2/3/4) are wired in series between the compressor outputs on RTRM1 (CHP 1/2) and RTRM2 (CHP 3/4) and the compressor contactor coils. If one of the high pressure control switches opens, the respective RTRM senses a lack of current while calling for cooling and locks the compressor out.

On dual circuit units, if the high pressure control opens, the compressor on the affected circuit is locked out. A manual reset for the affected circuit is required.

Space Temperature / RH Sensor (Optional)

Field installed, wall mounted combination temperature/humidity sensor (BAYSENS036A) to control space cooling, heating and dew point.

High Temperature Sensor

The Discharge Air Temperature Sensor (DTC) supplies a continuous signal to the MCM. Factory setting for Discharge Air Temperature (DTC) Maximum Discharge Air Temperature Setpoint (MDTS) is 120°F (range 80–120°F), the unit will be shut down, and require a manual restart if Discharge Air Temperature exceeds MDTS for 10 minutes (adj 10–25 minutes). If DAT exceeds Discharge Air High Temperature Cutoff (DHCS) of 125°F for 10 minutes for gas heat and 90°F for electric heat, the unit will shut down and require manual restart.

Outdoor Air Temperature and Relative Humidity Sensor

This factory installed combination outdoor air sensor located in the outdoor air hood is designed to sense both outdoor air temperature and relative humidity for use by the microprocessor controller to make required ventilation, cooling, dehumidification and heating decisions.

Control Input (Occupied / Unoccupied)

Terminals are provided on the terminal strip labeled OAUTS for a field installed dry contact or switch closure to put the unit in the Occupied or Unoccupied modes.

Hot Gas Reheat

This option shall consist of a hot-gas reheat coil located on the leaving air side of the evaporator.

100 Percent Outdoor Air Hood with Damper and Filters

Factory-installed and -integrated 100 percent outdoor air hood with damper controlled by a direct coupled actuator and 2 in. (50.80 mm) permanent and washable aluminum mesh filters (mist eliminators) removable through a hinged access panel. The unit can be factory provided with an optional 100 percent return air damper controlled by a direct coupled actuator that is electrically interlocked with the outdoor air damper.

Modulating Indirect Fired Gas Burner

The unit will have fully modulating, high turndown, indirect fired gas heat. The heating section will include high turn-down burners and a stainless steel tubular heat exchanger. The heat exchanger will be constructed of type 439 stainless steel and be a tubular design capable of

draining internal condensate. External flue to be constructed of type 304 stainless steel.

Units will be suitable for use with natural gas or Liquid Propane (LP) gas.

Through the Base Electrical with Disconnect Switch

Factory installed 3-pole, molded case disconnect switch with provisions for through the base electrical connections will be included. The disconnect switch, with integral overcurrent circuit breaker, will be installed in the unit in a water tight enclosure with access through a hinged door. Factory wiring will be provided from the switch to the unit high voltage terminal block. The switch will be UL/CSA agency recognized.

Hinged Access Doors

Hinged access doors with hold open brackets will be factory-installed.

Electric Heat

The unit may have four stage or fully modulating SCR controlled electric heat. The primary heating section will include open coil heating elements, automatic and manual cut-outs, low voltage controls, air proving switch, maximum 48 amps per circuit and fusing for heaters over 48 amps. For ductwork installation, refer to [“Ductwork,” p. 29.](#)

Supply and Exhaust Piezo Fan Rings

Air flow monitoring measuring fan suction and cone pressure differential to determine fan air flow.

ERV

Energy Recovery Wheels rotate between the incoming outdoor air stream and the building exhaust air stream. As the wheel rotates, it transfers a percentage of the heat and moisture differential from one air stream to the other. Instead of wasting energy in the exhaust airstream, it is temporarily captured by the energy transfer media and then released to preheat, pre-cool, humidify, or dehumidify the incoming air.

ERV

Energy Recovery Wheels rotate between the incoming outdoor air stream and the building exhaust air stream. As the wheel rotates, it transfers a percentage of the heat and moisture differential from one air stream to the other. Instead of wasting energy in the exhaust airstream, it is temporarily captured by the energy transfer media and then released to preheat, pre-cool, humidify, or dehumidify the incoming air.



General Information

Hot Water Coils

This option shall consist of a hot water coil located in the primary heat position. Hot water valve is to be field provided.

Suction Pressure Monitoring

All units with compressors will come standard with a refrigeration suction pressure transducer on Circuit 1, and on Circuit 2 when the unit has a digital scroll on the second circuit.

Head Pressure Control

Condenser fans to be controlled via VFD to maintain adjustable pressure to increase reheat capacity where applicable and low ambient control.

Unit Inspection

⚠ WARNING

Fiberglass Wool!

Product may contain fiberglass wool. Disturbing the insulation in this product during installation, maintenance or repair will expose you to airborne particles of glass wool fibers and ceramic fibers known to the state of California to cause cancer through inhalation. Glass wool fibers may also cause respiratory, skin or eye irritation.

⚠ AVERTISSEMENT

Laine de verre!

Le produit peut contenir de la laine de verre. Des interventions inappropriées sur l'isolation de ce produit pendant les opérations d'installation, d'entretien ou de réparation vous exposent à des particules aériennes de fibres de verre ou de fibres céramiques, responsables selon la législation américaine (état de Californie) de risques de cancers par inhalation. Les fibres de verre peuvent aussi provoquer des phénomènes d'irritation au niveau du système respiratoire, de la peau ou des yeux.

As soon as the unit arrives at the job site:

- Verify that the nameplate data matches the data on the sales order and bill of lading (including electrical data).
- Verify that the power supply complies with the unit nameplate specifications.
- Visually inspect the exterior of the unit, including the roof, for signs of shipping damage.
- Visually inspect the internal components for shipping damage as soon as possible after delivery and before it is stored. Do *not* walk on the sheet metal base pans.

- If concealed damage is discovered, notify the carrier's terminal of damage immediately by phone and by mail. Concealed damage must be reported within 15 days.

Request an immediate joint inspection of the damage by the carrier and the consignee. Do not remove damaged material from the receiving location. Take photos of the damage, if possible. The owner must provide reasonable evidence that the damage did not occur after delivery.

- Notify the appropriate sales representative before installing or repairing a damaged unit.
- Avoid breathing fiberglass dust.
- Use a NIOSH approved dust/mist respirator.
- Avoid contact with the skin or eyes. Wear long-sleeved, loose-fitting clothing, gloves, and eye protection.
- Wash clothes separately from other clothing: rinse washer thoroughly.
- Operations such as sawing, blowing, tear-out, and spraying may generate fiber concentrations requiring additional respiratory protection. Use the appropriate NIOSH approved respiration in these situations.

First Aid Measures

Eye Contact

Flush eyes with water to remove dust. If symptoms persist, seek medical attention.

Skin Contact

Wash affected areas gently with soap and warm water after handling.

Storage

Take precautions to prevent condensate from forming inside the unit's electrical compartments and motors if:

- the unit is stored before it is installed; or,
- the unit is set on the roof curb, and temporary heat is provided in the building. Isolate all side panel service entrances and base pan openings (e.g., conduit holes, S/A and R/A openings, and flue openings) from the ambient air until the unit is ready for startup.

Note: Do not use the unit's heater for temporary heat without first completing the startup procedure detailed in "Startup," p. 52.

The manufacturer will not assume any responsibility for equipment damage resulting from condensate accumulation on the unit's electrical and/or mechanical components.

Unit Clearances

“Unit Clearances, Curb Dimensions, and Dimensional Data,” p. 16 contains figures that illustrate the minimum operating and service clearances for either a single or multiple unit installation. These clearances are the minimum distances necessary to assure adequate serviceability, cataloged unit capacity, and peak operating efficiency.

Providing less than the recommended clearances may result in condenser coil starvation, “short-circuiting” of exhaust or recirculation of hot condenser air.



Unit Clearances, Curb Dimensions, and Dimensional Data

⚠ WARNING

Combustible Materials!

Failure to maintain proper clearance between the unit heat exchanger, vent surfaces and combustible materials could cause a fire which could result in death or serious injury or property damage. Refer to unit nameplate and installation instructions for proper clearances.

⚠ AVERTISSEMENT

Matériaux combustibles!

Tout manquement à l'obligation de maintenir une distance appropriée entre l'échangeur de chaleur de l'unité, les surfaces de ventilation et les matériaux combustibles peut provoquer un incendie pouvant résulter en des blessures corporelles graves, voire mortelles, ou des dommages matériels. Reportez-vous à la plaque signalétique de l'unité et aux instructions d'installation pour connaître les distances appropriées.

OAD Units

Unit Clearances

Figure 1. Installation clearances for units with no powered exhaust or ERV, in. (cm)

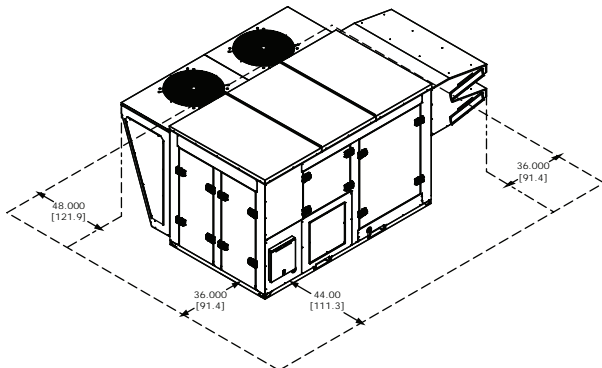
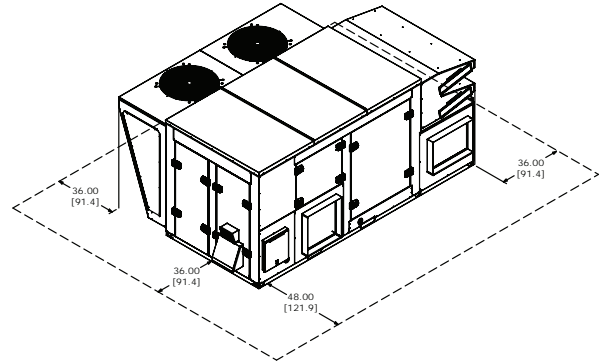
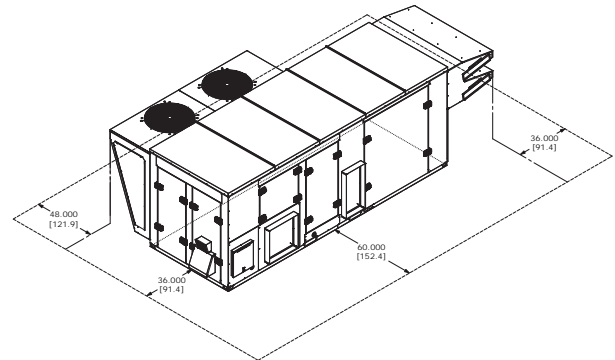

Figure 2. Installation clearances for unit with powered exhaust but no ERV, in. (cm)



Note: 72 in. (182.9 cm) clearance is required above the condenser fans.

Figure 3. Installation clearances for unit with ERV, in. (cm)



Note: 72 in. (182.9 cm) clearance is required above the condenser fans.

Figure 4. Unit to unit clearance, in. (cm)

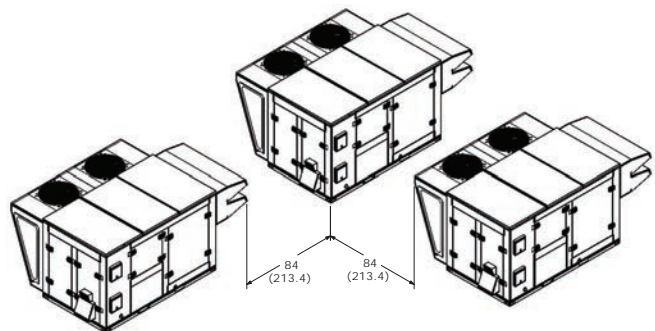

Curb Dimensions

Figure 5. Unit curb data for OAD cabinet with no powered exhaust or ERV, in. (cm)

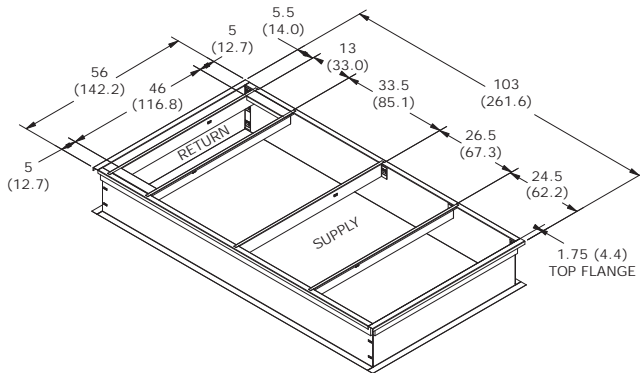

Figure 6. Unit curb data for OAD cabinet with powered exhaust but no ERV, in. (cm)

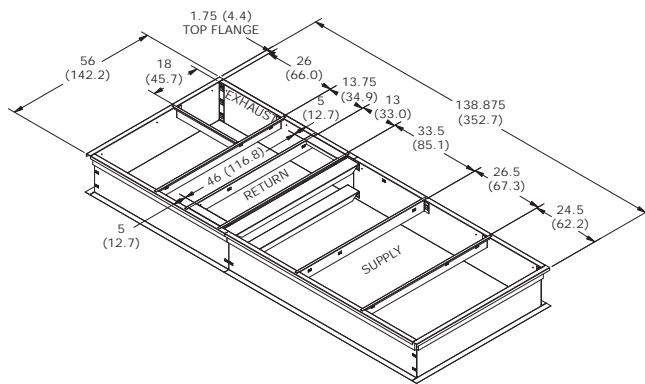
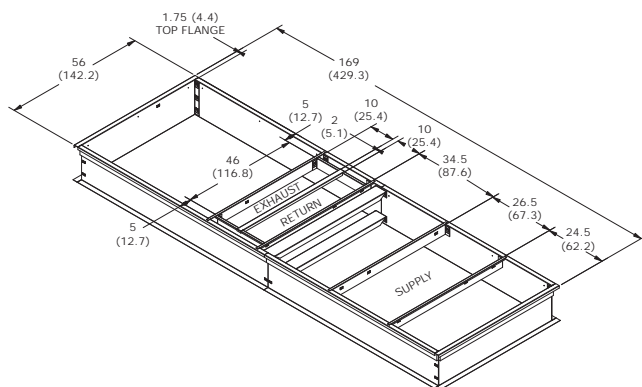
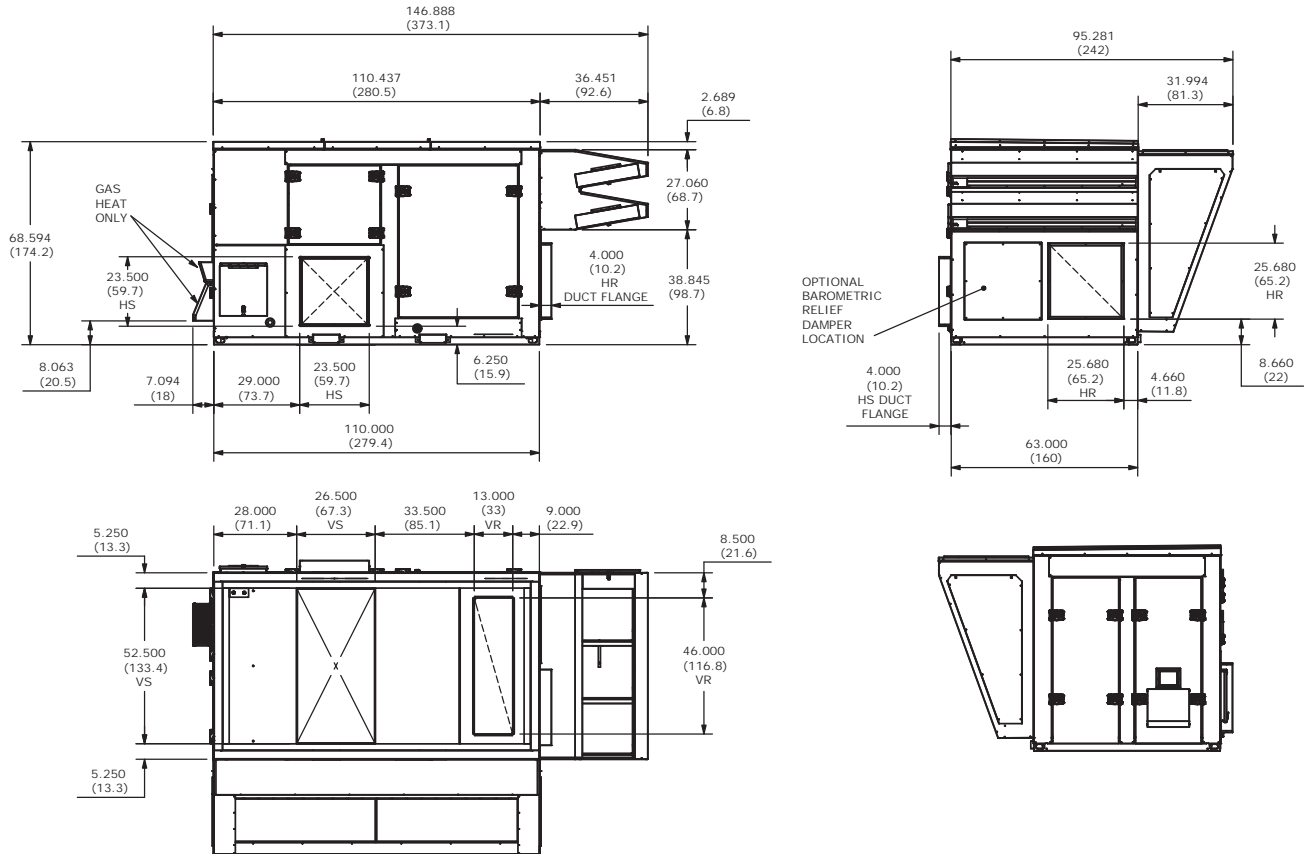

Figure 7. Unit curb data for OAD cabinet with ERV, in. (cm)



Dimensional Data

Figure 8. Unit dimensional data for OAD unit with no powered exhaust or ERV, in. (cm)



Notes:

- Sound attenuation package will add 16 in. (40.6 cm) to the height of the condenser fan section.
- Units with no cooling will have the same dimensions, less the condensing section.
- Units with chilled water cooling will have the same dimensions, less the condensing section, and with an 18 in. (45.7 cm) deep pipe cabinet added.
- Refer to project-specific unit submittals.

Unit Clearances, Curb Dimensions, and Dimensional Data

Figure 9. Unit dimensional data for OAD cabinet with powered exhaust but no ERV, in. (cm)

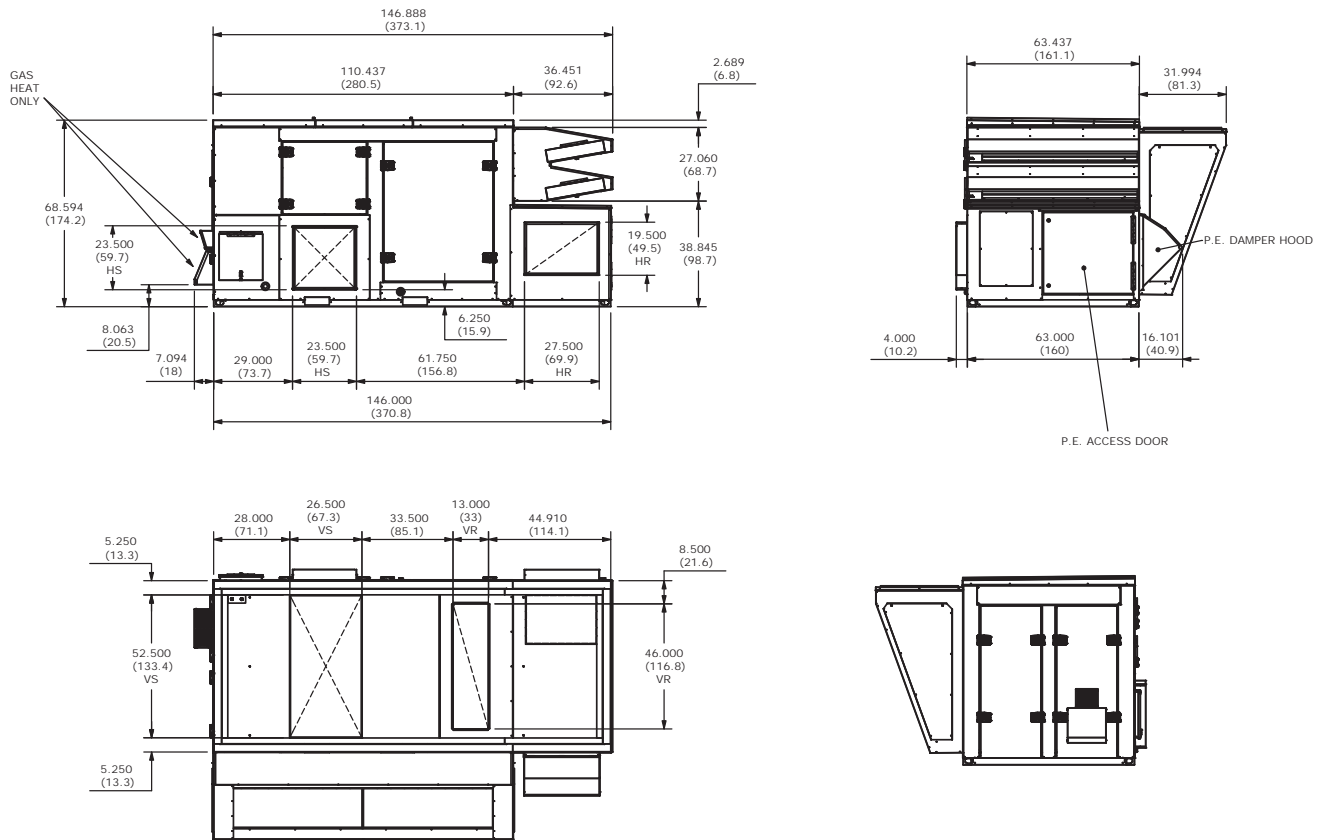

Notes:

- Sound attenuation package will add 16 in. (40.6 cm) to the height of the condenser fan section.
- Units with no cooling will have the same dimensions, less the condensing section.
- Units with chilled water cooling will have the same dimensions, less the condensing section, and with an 18 in. (45.7 cm) deep pipe cabinet added.
- Refer to project-specific unit submittals.



Unit Clearances, Curb Dimensions, and Dimensional Data

Figure 10. Unit dimensional data for OAD cabinet with ERV, in. (cm)

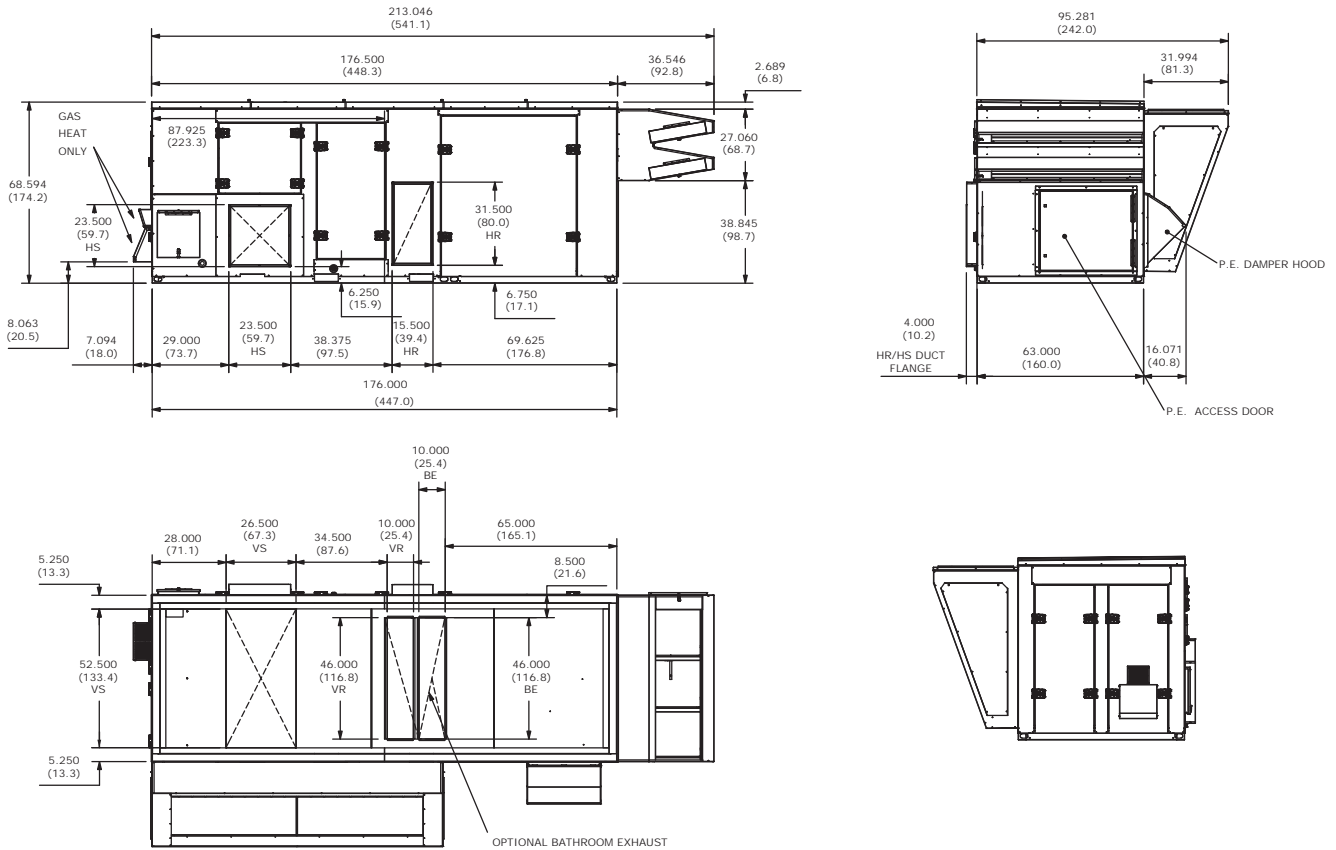

Notes:

- Sound attenuation package will add 16 in. (40.6 cm) to the height of the condenser fan section.
- Units with no cooling will have the same dimensions, less the condensing section.
- Units with chilled water cooling will have the same dimensions, less the condensing section, and with an 18 in. (45.7 cm) deep pipe cabinet added.
- Refer to project-specific unit submittals.

OAN Units

Unit Clearances

Figure 11. Installation clearances for units with no powered exhaust or ERV, in. (cm)

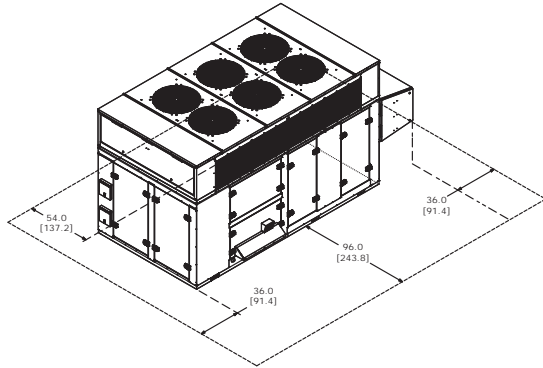
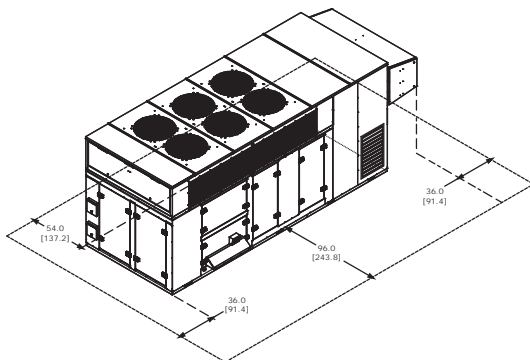
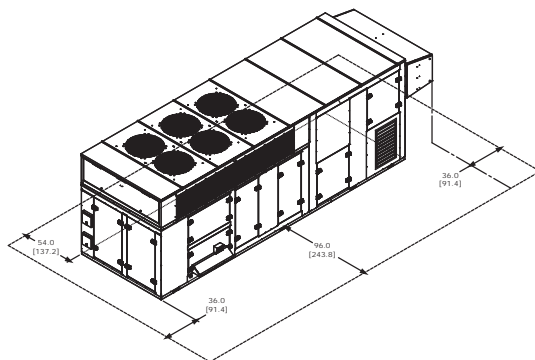

Figure 12. Installation clearances for unit with powered exhaust but no ERV, in. (cm)



Note: 72 in. (182.9 cm) clearance is required above the condenser fans.

Figure 13. Installation clearances for unit with ERV, in. (cm)



Note: 72 in. (182.9 cm) clearance is required above the condenser fans.

Figure 14. Unit to unit clearance, in. (cm)

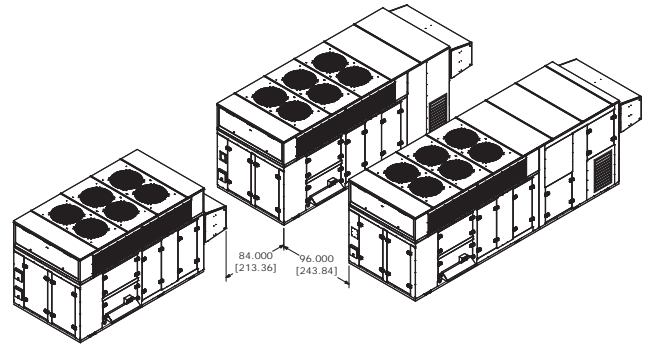

Curb Dimensions

Figure 15. Unit curb data for OAN cabinet with no powered exhaust or ERV, in. (cm)

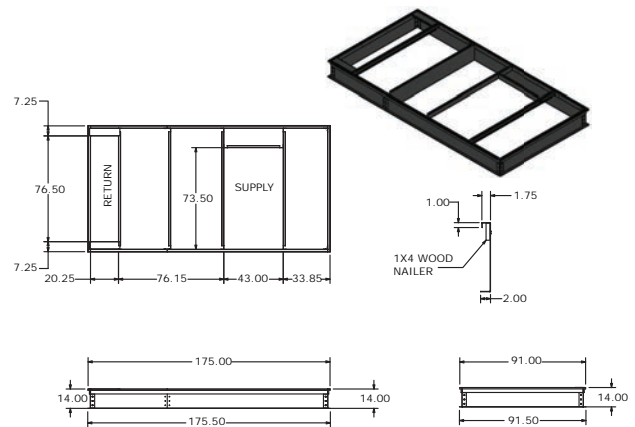
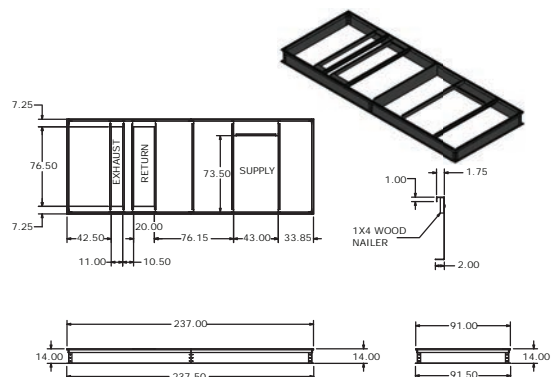
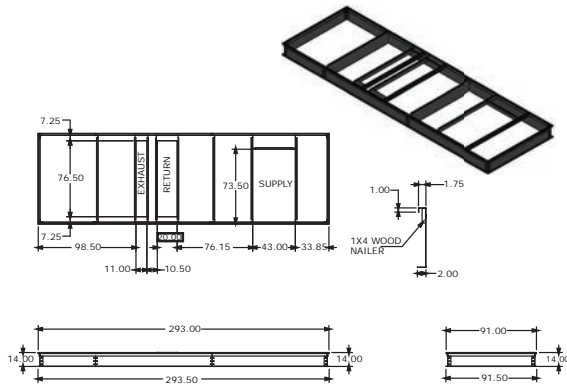

Figure 16. Unit curb data for OAN cabinet with powered exhaust but no ERV, in. (cm)



Unit Clearances, Curb Dimensions, and Dimensional Data

Figure 17. Unit curb data for OAN cabinet with ERV, in. (cm)



Dimensional Data

Figure 18. Unit dimensional data for OAN unit with no powered exhaust or ERV, in. (cm)

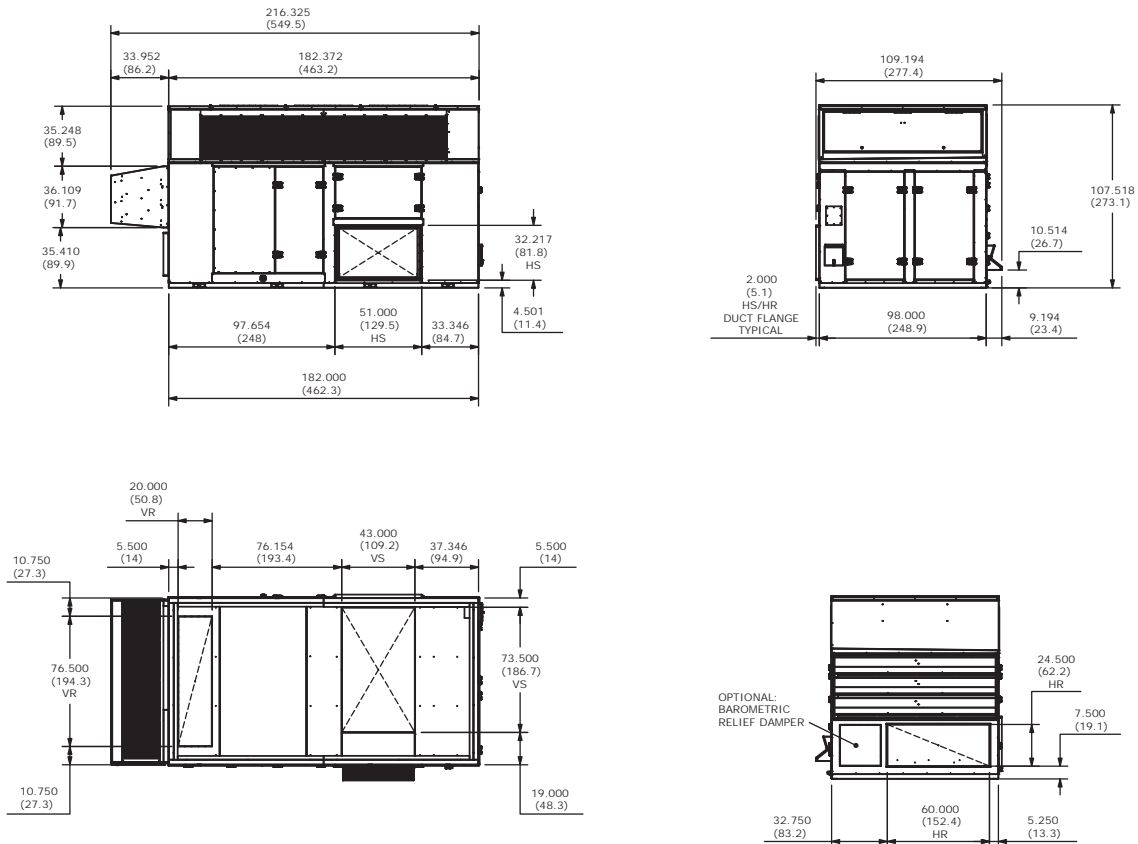

- Units with no cooling will have the same dimensions, less the condensing section.
- Units with chilled water cooling will have the same dimensions, less the condensing section, and with an 18 in. (45.7 cm) deep pipe cabinet added.
- Refer to project-specific unit submittals.

Unit Clearances, Curb Dimensions, and Dimensional Data

Figure 19. Unit dimensional data for OAN cabinet with powered exhaust but no ERV, in. (cm)

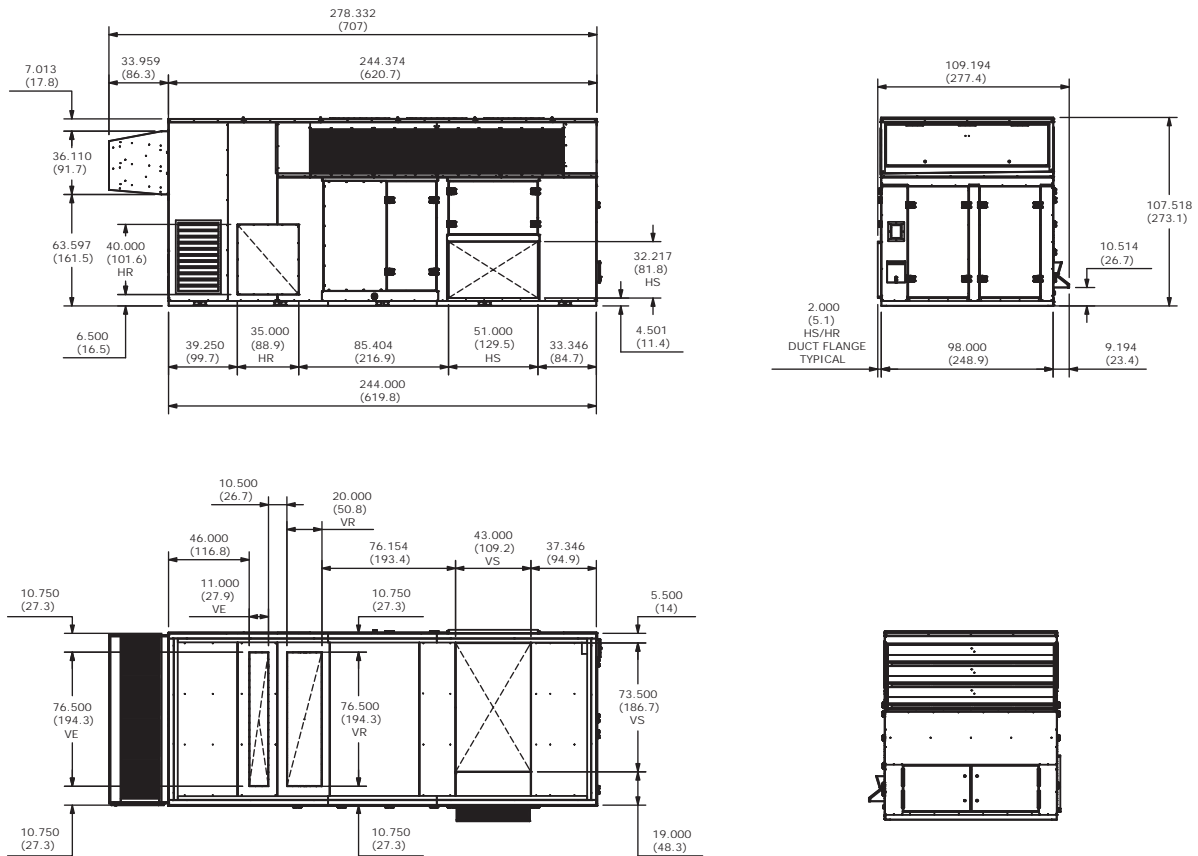

Notes:

- Units with no cooling will have the same dimensions, less the condensing section.
- Units with chilled water cooling will have the same dimensions, less the condensing section, and with an 18 in. (45.7 cm) deep pipe cabinet added.
- Refer to project-specific unit submittals.



Unit Weight and Rigging

⚠ WARNING

Heavy Objects!

Failure to follow instructions below or properly lift unit could result in unit dropping and possibly crushing operator/technician which could result in death or serious injury, and equipment or property-only damage. Ensure that all the lifting equipment used is properly rated for the weight of the unit being lifted. Each of the cables (chains or slings), hooks, and shackles used to lift the unit must be capable of supporting the entire weight of the unit. Lifting cables (chains or slings) may not be of the same length. Adjust as necessary for even unit lift.

⚠ AVERTISSEMENT

Objets lourds!

Le non-respect des instructions ci-dessous ou un levage inapproprié de l'unité peut provoquer sa chute voire écraser l'opérateur/le technicien, ce qui peut occasionner des blessures graves voire mortelles, et éventuellement endommager l'équipement ou provoquer des dégâts matériels. Assurez-vous que l'équipement de levage utilisé est adapté au poids de l'unité à soulever. Chaque câble (chaîne ou élingue), crochet ou manille utilisé pour le levage de l'unité doit être assez robuste pour supporter le poids total de l'unité. Les câbles, chaînes ou élingues de levage ne doivent pas être de longueur identique. Procédez au réglage afin de soulever l'unité de manière équilibrée.

⚠ WARNING

Improper Unit Lift!

Failure to properly lift unit could result in unit dropping and possibly crushing operator/technician which could result in death or serious injury, and equipment or property-only damage. Test lift unit approximately 24 inches to verify proper center of gravity lift point. To avoid dropping of unit, reposition lifting point if unit is not level.

⚠ AVERTISSEMENT

Levage inapproprié de l'unité!

Le non-respect des instructions ci-dessous ou un levage inapproprié de l'unité peut provoquer sa chute voire écraser l'opérateur/le technicien, ce qui peut occasionner des blessures graves voire mortelles, et éventuellement endommager l'équipement ou provoquer des dégâts matériels. Faites un test de levage de l'unité d'environ 60 cm (24 po) afin de vérifier que le point de levage correspond au centre de gravité de l'appareil. Pour éviter une chute de celle-ci, ajustez son point de levage si elle n'est pas à l'horizontale.

Unit Weight

Table 1. Typical unit weight, center of gravity, and corner weights (percentage of total weight) - air cooled units without powered exhaust or ERV

Model Number	Weight (lbs)		Center of Gravity (in.)		Corner weight (% of total weight) ^(a)			
	Min	Max	Length	Width	Corner A	Corner B	Corner C	Corner D
OADG010	2209	3578	54	41.1	20	15	36	29
OANG070	2209	3578	54.2	41.7	19	15	36	30
OADG015	2209	3578	53.3	41.1	19	16	36	29
OADG012	2430	3585	54.1	41.3	23	11	39	26
OADG017	2430	3585	53.4	41	21	14	37	28
OADG020	6220	8111	87.2	50.1	24	26	26	24
OANG040	6220	8111	87.2	50.1	24	26	26	24
OANG045	6220	8111	87.2	50.1	24	26	26	24
OANG050	6565	8505	91.4	50.2	24	26	26	24
OANG055	6565	8505	91.4	50.2	24	26	26	24
OANG060	6881	8883	96.0	50.5	24	26	26	24
OANG080	7038	9058	95.6	50.7	24	26	26	24

(a) Refer to Figure 21, p. 26 and Figure 22, p. 26 for corner locations.

Unit Weight and Rigging

Table 2. Typical unit weight, center of gravity, and corner weights (percentage of total weight) - air cooled units with powered exhaust but without ERV

Model Number	Weight (lbs)		Center of Gravity (in.)		Corner weight (% of total weight) ^(a)			
	Min	Max	Length	Width	Corner A	Corner B	Corner C	Corner D
OADG010	2970	4207	66	38.3	22	18	37	23
OADG012	2970	4207	62.5	40.2	23	13	44	20
OADG015	2970	4207	59.5	40.2	22	15	45	19
OADG017	3170	4407	60.5	39.9	22	15	44	19
OADG020	3170	4407	60.1	39.8	21	16	43	21
OANG040	7327	9888	106.8	49.9	25	27	28	20
OANG045	7327	9888	106.8	49.9	25	27	28	20
OANG050	7327	9888	106.8	49.9	25	27	28	20
OANG055	7674	10282	115.9	49.9	25	27	28	20
OANG060	7674	10282	115.9	49.9	25	27	28	20
OANG070	7990	10660	120.5	50.0	25	27	28	20
OANG080	8147	10834	125.0	50.5	25	27	28	20

(a) Refer to Figure 21, p. 26 and Figure 22, p. 26 for corner locations.

Table 3. Typical unit weight, center of gravity, and corner weights (percentage of total weight) - air cooled units with powered exhaust and ERV

Model Number	Weight (lbs)		Center of Gravity (in.)		Corner weight (% of total weight) ^(a)			
	Min	Max	Length	Width	Corner A	Corner B	Corner C	Corner D
OADG010	3405	4744	78.8	38.3	20	19	36	24
OADG012	3405	4744	78.4	38.3	20	19	36	25
OADG015	3405	4744	78	38.5	22	17	38	23
OADG017	3605	4944	77.3	38.7	21	18	38	23
OADG020	3605	4944	78.8	39.3	18	20	36	27
OANG040	8536	11563	143.4	49.2	24	25	30	21
OANG045	8536	11563	143.4	49.2	24	25	30	21
OANG050	8536	11563	143.4	49.2	24	25	30	21
OANG055	8883	11957	146.2	49.3	24	25	30	21
OANG060	8883	11957	146.2	49.3	24	25	30	21
OANG070	9199	12335	149.4	49.4	24	25	30	21
OANG080	9356	12510	151.8	49.5	24	25	30	21

(a) Refer to Figure 21, p. 26 and Figure 22, p. 26 for corner locations.

Figure 21. Corner weight locations - OAD top view

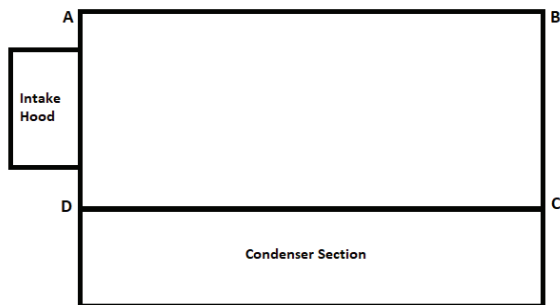

Figure 22. Corner weight locations - OAN top view



Rigging

Figure 24. Four-point lift (OAD cabinet with no exhaust fan or ERV)

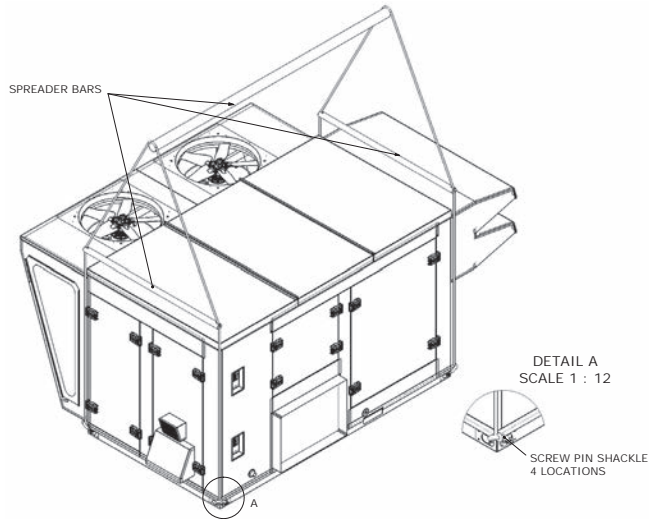

Figure 25. Four-point lift (OAD cabinet with exhaust fan and no ERV)

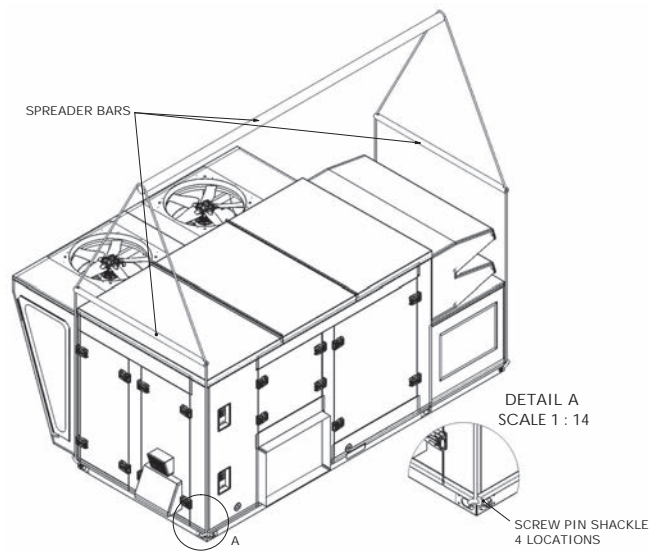

Figure 26. Six-point lift (OAD cabinet with ERV section)

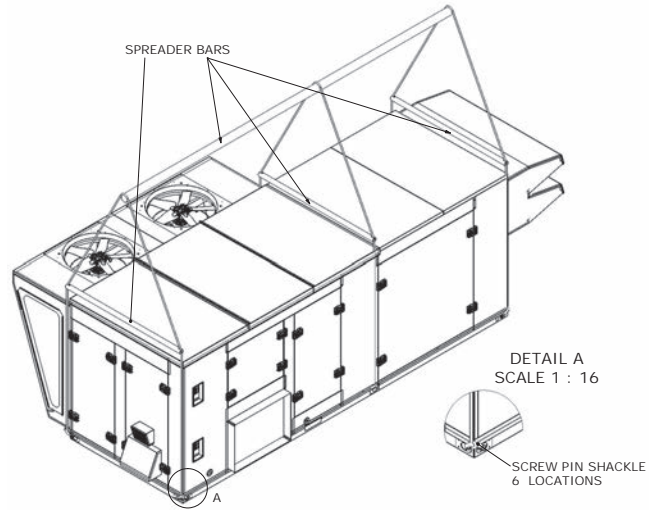
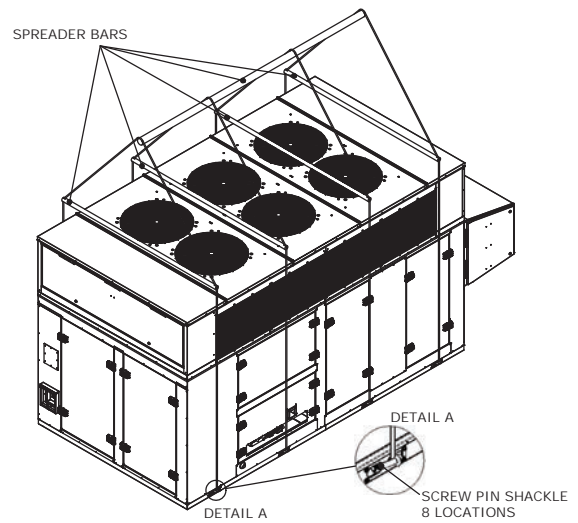
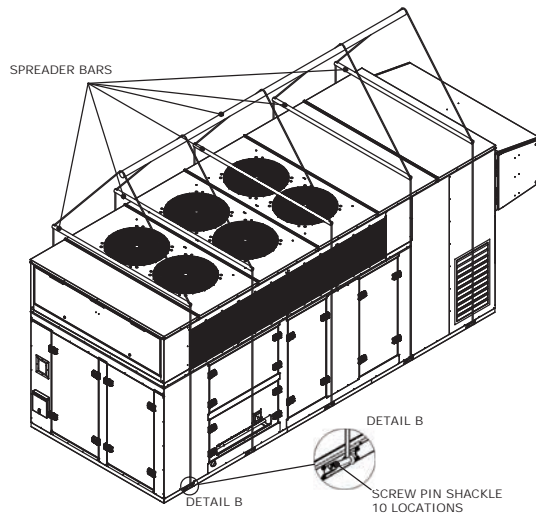

Figure 27. Eight-point lift (OAN cabinet with no exhaust fan or ERV)



Unit Weight and Rigging

Figure 28. Ten-point lift (OAN cabinet with exhaust fan and no ERV)



Before proceeding, refer to [Table 1, p. 25](#), [Table 2, p. 26](#) and [Table 3, p. 26](#) for typical unit operating weights and [Figure 23, p. 27](#) for rigging drawing.

1. Rig the unit as shown in [Figure 23, p. 27](#). Attach adequate strength lifting slings to all lifting brackets in the unit base rail. Do not use cables, chains, or slings except as shown.
2. Install a lifting bar, as shown in [Figure 23, p. 27](#), to protect the unit and to facilitate a uniform lift. The minimum distance between the lifting hook and the top of the unit should be 7 feet.
3. Test-lift the unit to ensure it is properly rigged and balanced, make any necessary rigging adjustments.
4. Lift the unit and position it into place. Remove fork pockets prior to setting on the curb.
5. Downflow units; align the base rail of the unit with the curb rail while lowering the unit onto the curb. Make sure that the gasket on the curb is not damaged while positioning the unit.

Figure 29. Ten-point lift (OAN cabinet with ERV section)

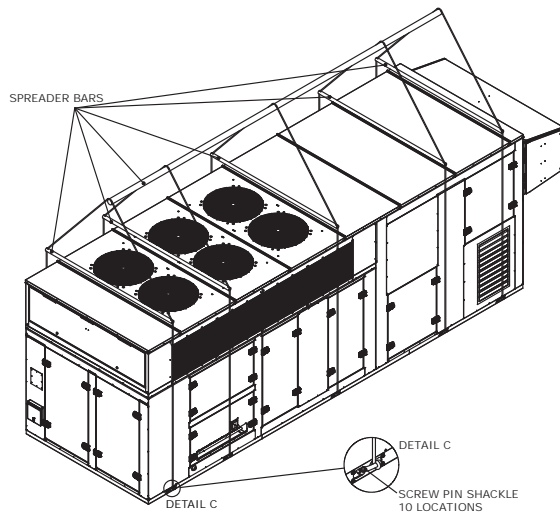

Installation

⚠ WARNING

Hazardous Service Procedures!

Failure to follow all precautions in this manual and on the tags, stickers, and labels could result in death or serious injury.

Technicians, in order to protect themselves from potential electrical, mechanical, and chemical hazards, **MUST** follow precautions in this manual and on the tags, stickers, and labels, as well as the following instructions: Unless specified otherwise, disconnect all electrical power including remote disconnect and discharge all energy storing devices such as capacitors before servicing. Follow proper lockout/tagout procedures to ensure the power can not be inadvertently energized. When necessary to work with live electrical components, have a qualified licensed electrician or other individual who has been trained in handling live electrical components perform these tasks.

⚠ AVERTISSEMENT

Procédures d'entretien dangereuses!

Le non-respect de toutes les précautions contenues dans ce manuel ainsi que sur les étiquettes et les autocollants peut entraîner des blessures graves voire mortelles.

Les techniciens, afin d'être protégés des éventuels risques électriques, mécaniques et chimiques, **DOIVENT** suivre les précautions contenues dans ce manuel, sur les étiquettes et les autocollants, ainsi que les instructions suivantes : Sauf indication contraire, coupez toute l'alimentation électrique y compris les disjoncteurs à distance et déchargez tous les dispositifs de stockage d'énergie comme les condensateurs avant l'entretien. Respectez les procédures de verrouillage et d'étiquetage appropriées pour éviter tout risque de remise sous tension accidentelle. S'il est nécessaire de travailler avec des composants électriques sous tension, demandez à un électricien qualifié et agréé ou à une autre personne ayant la formation nécessaire pour manipuler des composants électriques sous tension d'exécuter ces tâches.

Ductwork

Elbows with turning vanes or splitters are recommended to minimize air noise due to turbulence and to reduce static pressure.

When attaching the ductwork to the unit, provide a water-tight flexible connector at the unit to prevent operating sounds from transmitting through the ductwork.

All outdoor ductwork between the unit and the structure should be weather proofed after installation is completed.

Note: For sound consideration, cut holes in the roof deck only for the ductwork penetrations. Do not cut out the roof deck within the entire curb perimeter. All

ductwork must be installed and connected to top of roof curb before the unit is set on curb.

If a Curb Accessory Kit is not used:

1. Be sure to use flexible duct connections at the unit.
2. Gaskets must be installed around the curb perimeter flange and the supply and return air opening flanges.

Note: For units with electric heat in the primary heating position, refer to [Figure 30](#).

Figure 30.

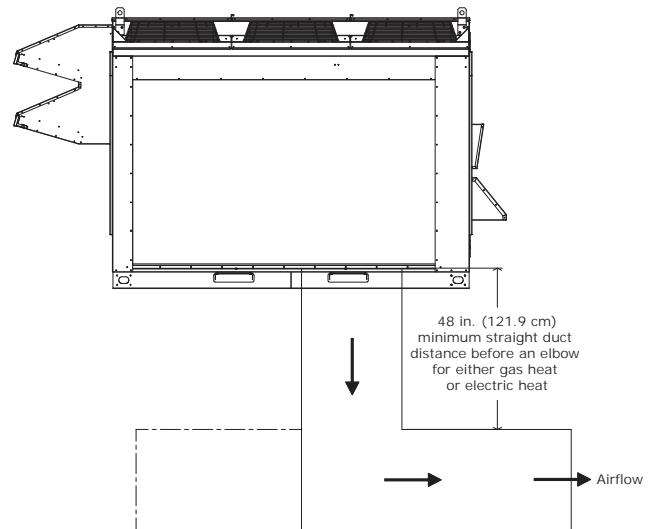

Important: Bottom discharge units with open coil electric heater in primary heat location require discharge duct with 90° elbow. This is a **MANDATORY** installation requirement.

Note: A minimum 48" of straight duct is required before an elbow. This is a requirement for both vertical and horizontal discharge regardless of heat type.

For units with Indirect Fired Gas Heat:

- Ductwork leaving unit should not have an immediate duct tee.
- If possible allow 4 feet vertical duct before first duct tee.
- Ensure duct work does not have an extreme transition at the outlet of the unit. Extreme transitions can cause restriction of airflow and high limit trips (as shown in [Figure 31](#)).
- Discharge Air sensor should be placed in the center of the ductwork at least 4 feet from the unit or after the first 90° bend.

Figure 31. Extreme transition in duct work

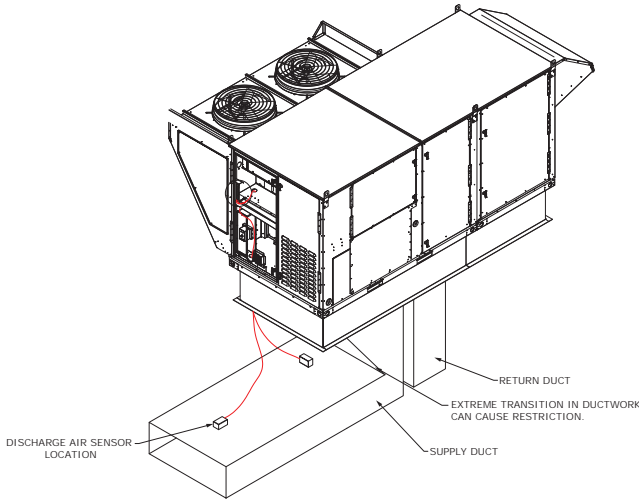

General Unit Requirements

The checklist listed below is a summary of the steps required to successfully install a commercial unit. This checklist is intended to acquaint the installing personnel with what is required in the installation process. **It does not replace the detailed instructions called out in the applicable sections of this manual.**

- Check the unit for shipping damage and material shortage. File a freight claim and notify appropriate sales representative if damage or shortage is discovered.
- Verify that the unit nameplate model, options, and voltage are correct.
- Verify that the installation location of the unit will provide the required clearance for proper operation.
- Assemble and install the roof curb (if applicable). Refer to the latest edition of the curb installers guide that ships with each curb kit. Check curb for level installation; if not level, shim as required.
- Rigging unit (refer to [“Unit Weight and Rigging,” p. 25](#)).
- Set the unit onto the curb; check for level.
- Ensure unit-to-curb seal is tight and without buckles or cracks.
- Install and connect proper condensate drain line to the evaporator condensate pan drain connection (see [Figure 32, p. 31](#)).

Main Electrical Power Requirements

- Verify that the power supply complies with the unit nameplate specifications.
- Inspect all control panel components; tighten any loose connections.
- Connect properly sized and protected power supply wiring to a field-supplied/-installed disconnect switch and to the main power terminal block (HTB1) in the unit control panel.
- Connect properly-sized earth ground.

Note: All field-installed wiring must comply with NEC and applicable local codes.

Condensate Drain Configuration

OAU units are selected based on dehumidification capability. As such, condensate can form at a high rate. Therefore, the OAU drain pan and condensate line are sized and designed accordingly. However, an often-overlooked element of proper condensate drainage is proper P-Trap and drain line sizing and installation. An incorrectly-designed and -installed P-Trap can restrict condensate flow or cause water in the condensate drain pan to “spit” or “geyser” which may cause condensate overflow. Carefully install and trap the drain pan to ensure adequate condensate removal under all conditions.

An evaporator condensate drain connection is provided on each unit. Refer to [Figure 38, p. 33](#) for the appropriate drain location.

A condensate trap must be installed at the unit due to the drain connection being on the “negative pressure” side of the fan. Install the P-Trap using the guidelines in [Figure 32](#).

Pitch drain lines connected to P-Trap at least 1/2 inch for every 10 feet of horizontal run to assure proper condensate flow. Do not allow the horizontal run to sag causing a possible double-trap condition which could result in condensate backup due to “air lock”.

Figure 32. Condensate trap installation

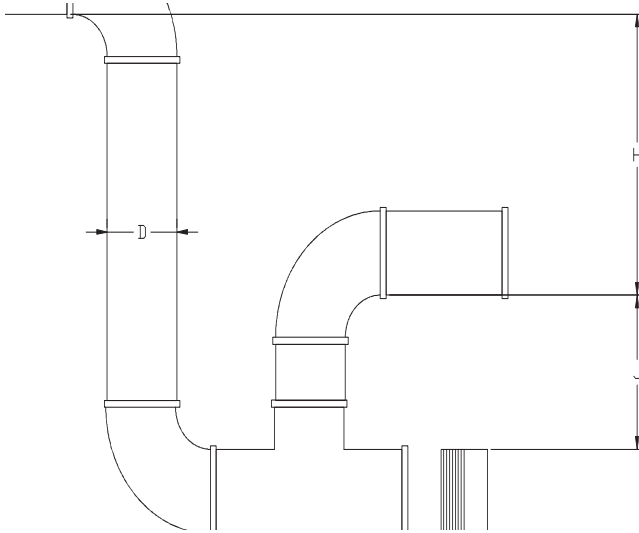

D = Pipe diameter; refer to [Figure 38, p. 33](#) for correct pipe diameter
 H = Internal static pressure (in wg) + 1 in.
 J = H x 0.5
 L = H + J + D

Notes:

1. Pitch drain at least 1/2 in. per 10 ft horizontal run.
2. Condensate drain pan will not drain properly if P-trap is not primed and of adequate height to allow for cabinet operating negative pressure.

Hot Water Connection Size and Location

Figure 33. OAD water inlet and outlet, in. (cm)

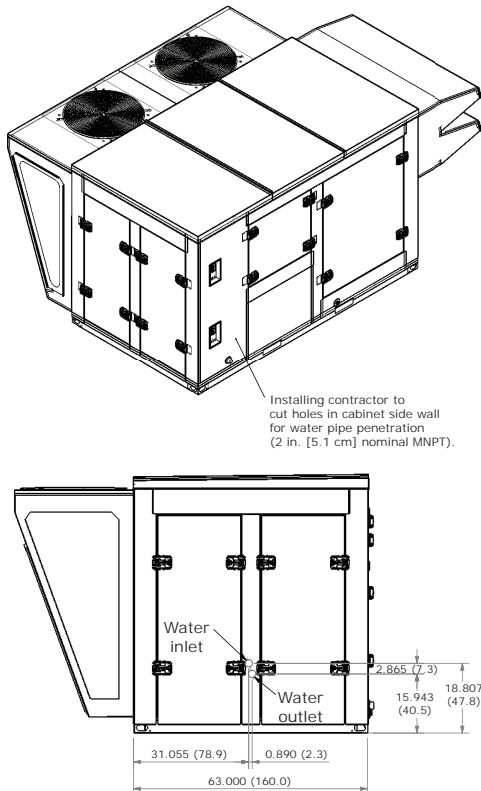
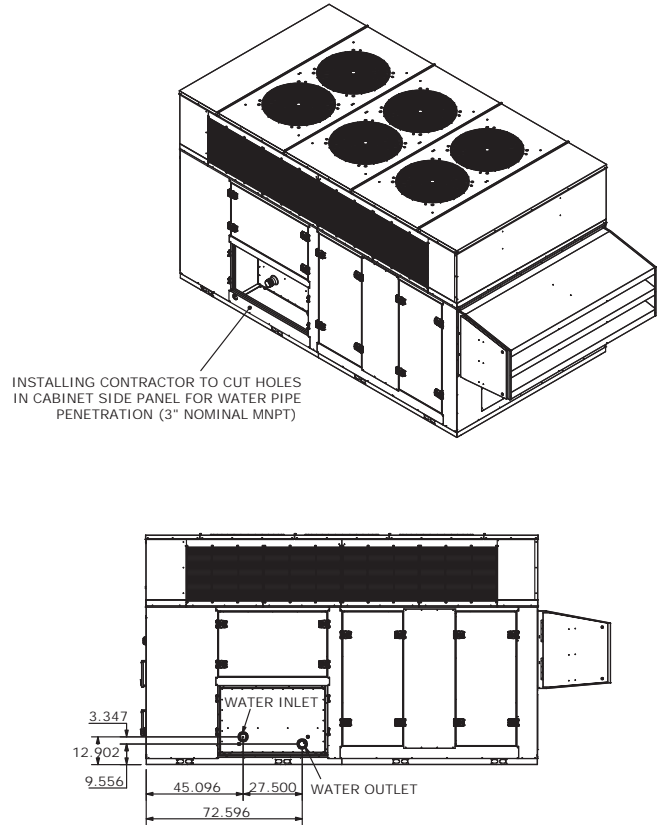

Figure 34. OAN water inlet and outlet, in. (cm)



Chilled Water Connection Size and Location

Figure 35. Outdoor air chilled water cooling pipe chase-connections

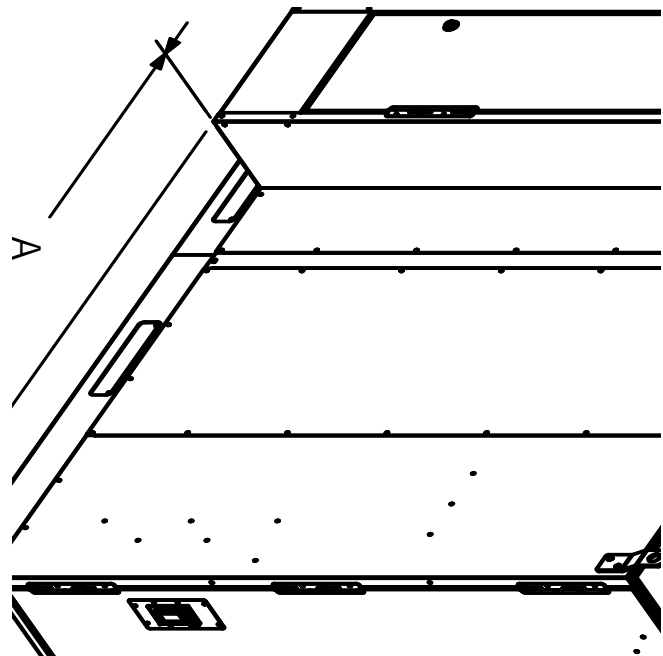

Table 4. Chilled water pipe chase location, in. (cm)

Unit	A	B	C	D
OAD	64.25 (163.2)	30.00 (76.2)	18.00 (45.7)	3.50 (8.9)
OAN	92.64 (235.3)	30.00 (76.2)	18.00 (45.7)	2.81 (7.1)

Table 5. Chilled water connection size (MPT-in.)

Unit Size	MPT-in. (cm)
OAD, 4-row	1.5 (3.8)
OAD, 6-row	2.0 (5.1)
OAN, 4-row	2.5 (6.3)
OAN, 6-row	3.0 (7.6)

Filter Installation

Each unit ships with 2-in. (5.1-cm) permanent filters (mist eliminators) installed in the air inlet hood. The quantity of filters is determined by unit size. Access to the filters is through the hinged filter access panel on the air intake hood. In addition to the filters in the intake hood, there is a separate bank of filters accessible through the evaporator coil compartment door. Filter type, size, and quantity are determined by selected filter option and unit size.

Note: Do not operate the unit without filters.

Field Installed Power Wiring

⚠ WARNING

Proper Field Wiring and Grounding Required!

Failure to follow code could result in death or serious injury. All field wiring **MUST** be performed by qualified personnel. Improperly installed and grounded field wiring poses **FIRE** and **ELECTROCUTION** hazards. To avoid these hazards, you **MUST** follow requirements for field wiring installation and grounding as described in **NEC** and your local/state electrical codes.

⚠ AVERTISSEMENT

Câblage sur site et mise à la terre corrects nécessaires!

Le non-respect de la réglementation peut entraîner des blessures graves, voire mortelles. Il est **IMPÉRATIF** de confier l'ensemble du câblage sur site à un électricien qualifié. Un câblage sur site mal installé ou mal mis à la terre constitue des risques **D'INCENDIE** et **D'ÉLECTROCUTION**. Pour éviter ces risques, il est **IMPÉRATIF** de respecter les obligations en matière de pose de câblage sur site et de mise à la terre tel que stipulé dans les règles du **NEC** et dans les réglementations électriques locales/nationales.

An overall dimensional layout for the standard field installed wiring entrance into the unit is illustrated in

Figure 38, p. 33. To ensure that the unit's supply power wiring is properly sized and installed, refer to the following guidelines.

Figure 36. OAD power entrance

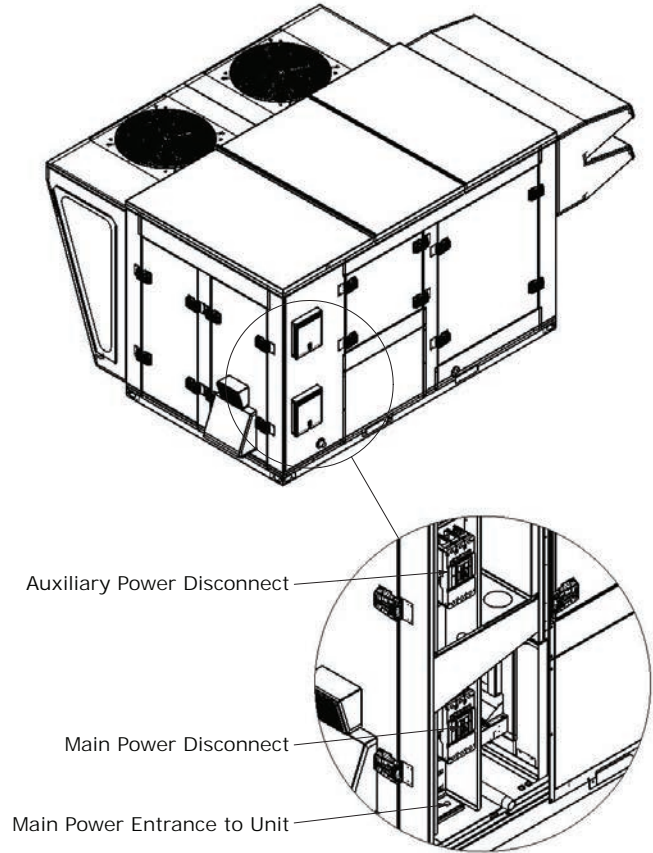

Figure 37. OAN power entrance

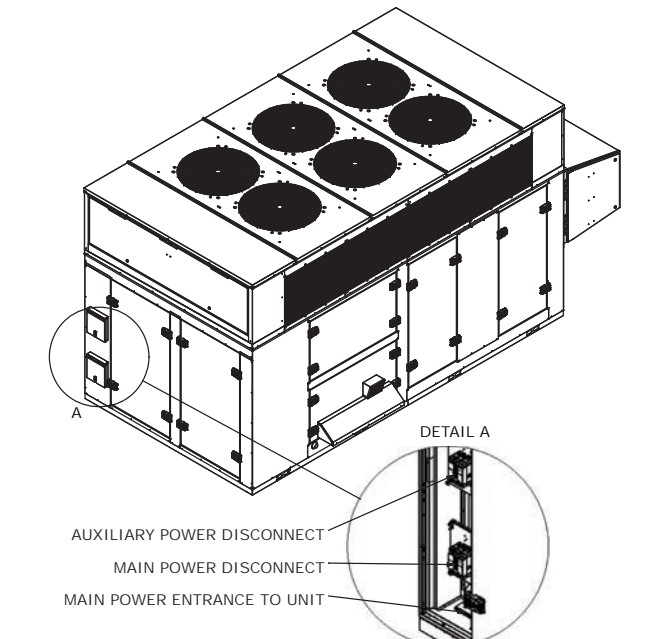

Figure 38. OAD utility connections, in. (cm)

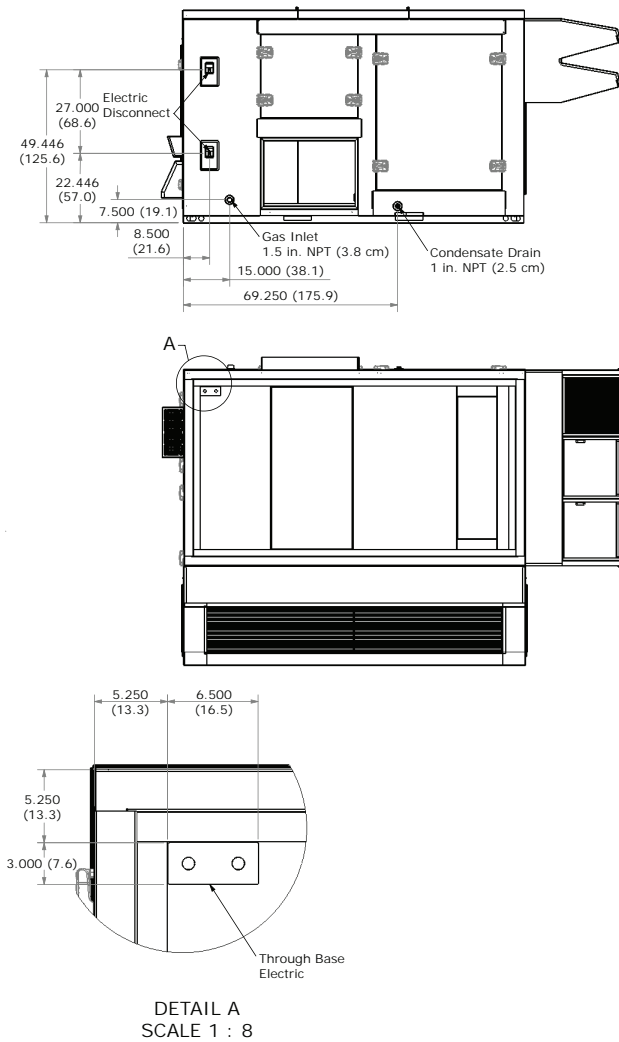
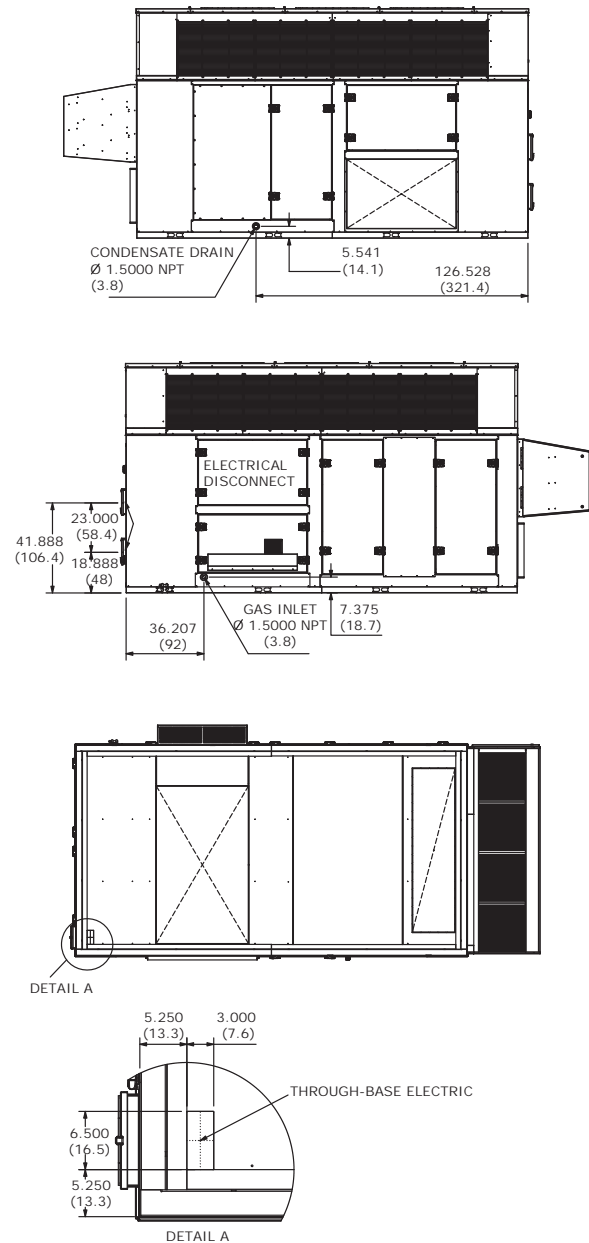

Figure 39. OAN utility connections, in. (cm)



Note: All field installed wiring must conform to NEC guidelines as well as State and Local codes.

Verify that the power supply available is compatible with the unit's nameplate ratings. The available supply power must be within 10 percent of the rated voltage stamped on the nameplate. Use only copper conductors to connect the power supply to the unit.

Main Unit Power

⚠ WARNING

Hazardous Voltage!

Failure to disconnect power before servicing could result in death or serious injury. Disconnect all electric power, including remote disconnects before servicing. Follow proper lockout/tagout procedures to ensure the power can not be inadvertently energized.

⚠ AVERTISSEMENT

Risque d'électrocution!

Le non-respect de cette consigne peut entraîner des blessures graves, voire mortelles. Avant toute intervention, coupez l'alimentation électrique, y compris aux sectionneurs à distance. Suivez scrupuleusement les procédures de verrouillage/mise hors service préconisées pour empêcher tout rétablissement accidentel de l'alimentation électrique.

NOTICE

Use Copper Conductors Only!

Failure to use copper conductors could result in equipment damage as unit terminals are not designed to accept other types of conductors.

Standard Wiring

⚠ WARNING

Proper Field Wiring and Grounding Required!

Failure to follow code could result in death or serious injury. All field wiring **MUST** be performed by qualified personnel. Improperly installed and grounded field wiring poses **FIRE** and **ELECTROCUTION** hazards. To avoid these hazards, you **MUST** follow requirements for field wiring installation and grounding as described in **NEC** and your local/state electrical codes.

⚠ AVERTISSEMENT

Câblage sur site et mise à la terre corrects nécessaires!

Le non-respect de la réglementation peut entraîner des blessures graves, voire mortelles. Il est **IMPÉRATIF** de confier l'ensemble du câblage sur site à un électricien qualifié. Un câblage sur site mal installé ou mal mis à la terre constitue des risques **D'INCENDIE** et **D'ÉLECTROCUTION**. Pour éviter ces risques, il est **IMPÉRATIF** de respecter les obligations en matière de pose de câblage sur site et de mise à la terre tel que stipulé dans les règles du **NEC** et dans les réglementations électriques locales/nationales.

The electrical service must be protected from over current and short circuit conditions in accordance with NEC requirements. Protection devices must be sized according to the electrical data on the nameplate.

1. Location of the applicable electrical service entrance is illustrated in [Figure 38, p. 33](#). Complete the unit's power wiring connections onto either; the main terminal block HTB1 inside the unit control panel, the factory mounted non-fused disconnect switch (UCD) or circuit breaker (UCB), or the electric heat non-fused disconnect switch. Refer to the customer connection diagram that shipped with the unit for specific termination points.
2. Provide proper grounding for the unit in accordance with local and national codes.

Use the following checklist in conjunction with the checklist in "[General Unit Requirements](#)," p. 30 to ensure that the unit is properly installed and ready for operation.

- Verify that the correct size and number of filters are in place.
- Inspect the interior of the unit for tools and debris and install all panels in preparation for starting the unit.
- Check all electrical connections for tightness and "point of termination" accuracy.
- Verify condenser airflow is unobstructed.
- Verify that the condenser and indoor fans turn freely without rubbing and are properly tightened on the shafts.
- Check motor mounting bolts and inlet cone for tightness. Free spin wheel by hand to check for proper alignment of motor, wheel, and inlet cone. Record motor nameplate amps at unit-rated voltage.
- Check proper indoor fan wheel rotation. Wheel housing will be marked to indicate direction of proper rotation.
- With access doors closed and secured, operate blower at 100 percent speed. Check amp readout of amps output to indoor fan at VFD display to confirm operation within motor amp capacity.

Voltage Imbalance

⚠ WARNING

Live Electrical Components!

Failure to follow all electrical safety precautions when exposed to live electrical components could result in death or serious injury. When necessary to work with live electrical components, have a qualified licensed electrician or other individual who has been properly trained in handling live electrical components perform these tasks.

⚠ AVERTISSEMENT

Composants électriques sous tension!

Le non-respect de toutes les consignes de sécurité lors de la manipulation de composants électriques sous tension peut entraîner des blessures graves, voire mortelles. S'il est nécessaire de travailler avec des composants électriques sous tension, demandez à un électricien qualifié et agréé ou à une autre personne ayant la formation nécessaire pour manipuler des composants électriques sous tension d'exécuter ces tâches.

Three phase electrical power to the unit must meet stringent requirements for the unit to operate properly. Measure each leg (phase-to-phase) of the power supply. Each reading must fall within the utilization range stamped on the unit nameplate. If any of the readings do not fall within the proper tolerances, notify the power company to correct this situation before operating the unit.

Excessive three phase voltage imbalance between phases will cause motors to overheat and eventually fail. The maximum allowable voltage imbalance is 2.0 percent. Measure and record the voltage between phases 1, 2, and 3 and calculate the amount of imbalance as follows:

$$\% \text{ Voltage Imbalance} = 100 \times \frac{AV - VD}{AV} \text{ where;}$$

$$AV \text{ (Average Voltage)} = \frac{\text{Volt 1} + \text{Volt 2} + \text{Volt 3}}{3}$$

V1, V2, V3 = Line Voltage Readings

VD = Line Voltage reading that deviates the farthest from the average voltage.

Example: If the voltage readings of the supply power measured 221, 230, and 227, the average volts would be:

$$\frac{221 + 230 + 227}{3} = 226 \text{ Avg.}$$

VD (reading farthest from average) = 221

The percentage of Imbalance equals:

$$100 \times \frac{226 - 221}{226} = 2.2\%$$

The 2.2 percent imbalance in this example exceeds the maximum allowable imbalance of 2.0 percent. This much imbalance between phases can equal as much as a 20 percent current imbalance with a resulting increase in motor winding temperatures that will decrease motor life. If the voltage imbalance is over 2.0 percent, notify the proper agencies to correct the voltage problem before operating this equipment.

Electrical Phasing (Three-Phase Motors)

⚠ WARNING

Live Electrical Components!

Failure to follow all electrical safety precautions when exposed to live electrical components could result in death or serious injury. When necessary to work with live electrical components, have a qualified licensed electrician or other individual who has been properly trained in handling live electrical components perform these tasks.

⚠ AVERTISSEMENT

Composants électriques sous tension!

Le non-respect de toutes les consignes de sécurité lors de la manipulation de composants électriques sous tension peut entraîner des blessures graves, voire mortelles. S'il est nécessaire de travailler avec des composants électriques sous tension, demandez à un électricien qualifié et agréé ou à une autre personne ayant la formation nécessaire pour manipuler des composants électriques sous tension d'exécuter ces tâches.

The compressor motor(s) and the supply fan motor are internally connected for the proper rotation when the incoming power supply is phased as A to L1, B to L2, and C to L3.

Proper electrical supply phasing can be quickly determined and corrected before starting the unit by using an instrument such as an Associated Research Model 45 Phase Sequence Indicator and following these steps:

- Turn off the main source feeding power to the unit field-supplied or factory-installed main disconnect device (switch or circuit breaker).
- Close the unit disconnect device cover, leaving disconnect switch in the off position, and turn main source power on.

Installation

- Observe the ABC and CBA phase indicator lights on the face of the sequencer. The ABC indicator light will glow if the phase is ABC. If the CBA indicator light glows, turn main source power off and then open the unit main disconnect device cover and reverse any two power wires.
- Restore the main source power and recheck the phasing. If the phasing is correct, turn main source power off then open the unit main disconnect device cover, remove the phase sequence indicator, reinstall disconnect device cover and, leaving disconnect device in the off position, turn main power source to unit on.

Compressor Crankcase Heaters

⚠ WARNING

Live Electrical Components!

Failure to follow all electrical safety precautions when exposed to live electrical components could result in death or serious injury. When necessary to work with live electrical components, have a qualified licensed electrician or other individual who has been properly trained in handling live electrical components perform these tasks.

⚠ AVERTISSEMENT

Composants électriques sous tension!

Le non-respect de toutes les consignes de sécurité lors de la manipulation de composants électriques sous tension peut entraîner des blessures graves, voire mortelles. S'il est nécessaire de travailler avec des composants électriques sous tension, demandez à un électricien qualifié et agréé ou à une autre personne ayant la formation nécessaire pour manipuler des composants électriques sous tension d'exécuter ces tâches.

To prevent injury or death from electrocution, it is the responsibility of the technician to recognize this hazard and use extreme care when performing service procedures with the electrical power energized.

Each compressor shall be equipped with a crankcase heater. The proper operation of the crankcase heater is important to maintain an elevated compressor oil temperature during the "Off" cycle to reduce oil foaming during compressor starts. Oil foaming occurs when refrigerant condenses in the compressor and mixes with the oil. In lower ambient conditions, refrigerant migration to the compressor could increase.

When the compressor starts, the sudden reduction in crankcase pressure causes the liquid refrigerant to boil rapidly causing the oil to foam. This condition could damage compressor bearings due to reduced lubrication and could cause compressor mechanical failures.

Before initial start up, or if main power has been off for an extended period of time, compressor crankcase heater(s) should be operated for a minimum of 8 hours prior to compressor operation. With main power OFF, remove jumper between OAUTS terminals 9 and 10 (E-Stop). Turn main power to energize crankcase heater(s). At end of warm up period turn main power off, install 9-10 jumper, turn main power on, and resume normal operation.

Following crankcase heater warm-up, turn main power disconnect off, and install jumper on E-Stop terminals 9 and 10.

Turn Main disconnect "On".

Main Unit Display and ReliaTel Controls

When first powered "On", the controls perform self-diagnostic initialization to check that all internal controls are functional. The Status LED located on the Main Unit Display and the Liteport LED located on the RTRM module is turned "On" within one second of power-up if internal operation is okay.

Field-Installed Control Wiring

⚠ WARNING

Proper Field Wiring and Grounding Required!

Failure to follow code could result in death or serious injury. All field wiring **MUST** be performed by qualified personnel. Improperly installed and grounded field wiring poses **FIRE** and **ELECTROCUTION** hazards. To avoid these hazards, you **MUST** follow requirements for field wiring installation and grounding as described in NEC and your local/state electrical codes.

⚠ AVERTISSEMENT

Câblage sur site et mise à la terre corrects nécessaires!

Le non-respect de la réglementation peut entraîner des blessures graves, voire mortelles. Il est **IMPÉRATIF** d confier l'ensemble du câblage sur site à un électricien qualifié. Un câblage sur site mal installé ou mal mis à la terre constitue des risques **D'INCENDIE** et **D'ÉLECTROCUTION**. Pour éviter ces risques, il est **IMPÉRATIF** de respecter les obligations en matière de pose de câblage sur site et de mise à la terre tel que stipulé dans les règles du NEC et dans les réglementations électriques locales/nationales.

An overall layout of the various control options available with the required number of conductors for each control device is illustrated in [Figure 40, p. 38](#).

Note: All field wiring must conform to NEC guidelines as well as state and local codes.

Control Power Transformer

⚠ WARNING

Hazardous Voltage!

Failure to disconnect power before servicing could result in death or serious injury. Disconnect all electric power, including remote disconnects before servicing. Follow proper lockout/tagout procedures to ensure the power can not be inadvertently energized.

⚠ AVERTISSEMENT

Risque d'électrocution!

Le non-respect de cette consigne peut entraîner des blessures graves, voire mortelles. Avant toute intervention, coupez l'alimentation électrique, y compris aux sectionneurs à distance. Suivez scrupuleusement les procédures de verrouillage/mise hors service préconisées pour empêcher tout rétablissement accidentel de l'alimentation électrique.

The 24-volt control power transformers are to be used only with the accessories called out in this manual.

Transformers rated greater than 50 VA are equipped with internal circuit breakers. If a circuit breaker trips, turn "Off" all power to the unit before attempting to reset it.

The transformers are located in the control panel. The circuit breaker is located on the left side of the transformers and can be reset by pressing in on the black reset button.

Controls Using 24 Vac

⚠ WARNING

Hazardous Voltage!

Failure to disconnect power before servicing could result in death or serious injury. Disconnect all electric power, including remote disconnects before servicing. Follow proper lockout/tagout procedures to ensure the power can not be inadvertently energized.

⚠ AVERTISSEMENT

Risque d'électrocution!

Le non-respect de cette consigne peut entraîner des blessures graves, voire mortelles. Avant toute intervention, coupez l'alimentation électrique, y compris aux sectionneurs à distance. Suivez scrupuleusement les procédures de verrouillage/mise hors service préconisées pour empêcher tout rétablissement accidentel de l'alimentation électrique.

NOTICE

Use Copper Conductors Only!

Failure to use copper conductors could result in equipment damage as unit terminals are not designed to accept other types of conductors.

Before installing any connecting wiring, refer to [Figure 38, p. 33](#) for the electrical access locations provided on the unit and [Table 6](#) for AC conductor sizing guidelines, and:

1. Use copper conductors unless otherwise specified.
2. Ensure that the AC control wiring between the controls and the unit's termination point does not exceed three (3) ohms/ conductor for the length of the run.

Note: Resistance in excess of 3 ohms per conductor may cause component failure due to insufficient AC voltage supply.

3. Be sure to check all loads and conductors for grounds, shorts, and mis-wiring.
4. Do not run the AC low-voltage wiring in the same conduit with the high-voltage power wiring.

Table 6. 24 Vac conductors

Distance from Unit to Control	Recommended Wire Size
000–460 feet 000–140 m	18 gauge 0.75 mm ²
461–732 feet 104–223 m	16 gauge 1 mm ²

Controls Using DC Analog Input/Output (Standard Low Voltage Multiconductor Wire)

⚠ WARNING

Hazardous Voltage!

Failure to disconnect power before servicing could result in death or serious injury. Disconnect all electric power, including remote disconnects before servicing. Follow proper lockout/tagout procedures to ensure the power can not be inadvertently energized.

⚠ AVERTISSEMENT

Risque d'électrocution!

Le non-respect de cette consigne peut entraîner des blessures graves, voire mortelles. Avant toute intervention, coupez l'alimentation électrique, y compris aux sectionneurs à distance. Suivez scrupuleusement les procédures de verrouillage/mise hors service préconisées pour empêcher tout rétablissement accidentel de l'alimentation électrique.

Before installing any connecting wiring between the unit and components utilizing a DC analog input/output signal,

refer to [Figure 38, p. 33](#) for the electrical access locations provided on the unit.

1. [Table 7](#) lists the conductor sizing guidelines that must be followed when interconnecting the DC binary output devices and the system components utilizing a DC analog input/output signal to the unit.

Note: Resistance in excess of 2.5 ohms per conductor can cause deviations in the accuracy of the controls.

2. Ensure that the wiring between controls and the unit's termination point does not exceed 2.5 ohms/conductor for the length of the run.
3. Do not run the electrical wires transporting DC signals in or around conduit housing high voltage wires.

DC Conductors

Table 7. Zone sensor module wiring

Distance from Unit to Control	Recommended Wire Size
000–150 feet 0–45.7 m	22 gauge 0.33 mm ²
151–240 feet 46–73.1 m	20 gauge 0.50 mm ²
241–385 feet 73.5–117.3 m	18 gauge 0.75 mm ²
386–610 feet 117.7–185.9 m	16 gauge 1.3 mm ²
611–970 feet 186.2–295.7 m	14 gauge 2.0 mm ²

Figure 40. OAUTS Connection B

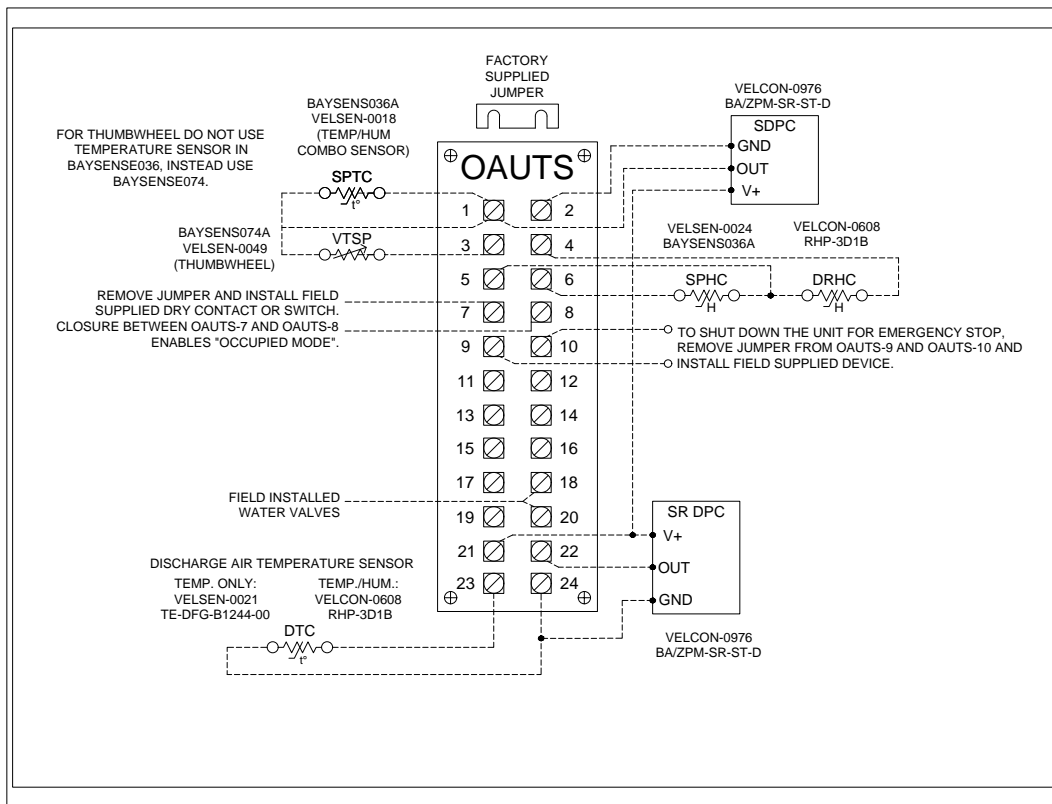

Factory-Provided Sensors

A discharge temperature sensor (VELSEN-0021) will be factory-provided for field installation in the supply duct. Refer to [Figure 47, p. 74](#) for installation instructions.

If space control is selected, a combination space temperature/humidity sensor (BAYSENS036A) will be factory-provided for field installation in the space. Refer to [Figure 48, p. 75](#) for installation instructions.

If multi-zone VAV control is selected, a static pressure sensor (VELCON-0350) will be factory-provided for field

installation in the supply duct or space. Refer to [Figure 50, p. 77](#) for installation instructions.

If modulating OA/RA dampers w/economizer and an exhaust fan are selected, a duct static pressure sensor (VELCON-0350) will be factory-provided for field installation in the return duct. Refer to [Figure 50, p. 77](#) for installation instructions.



Pre-Start Check List

Task	Initial	Date
1. Voltage is present and landed at equipment.		
2. Gas piping is complete and landed at each component. Inlet gas pressure to be between 7 in. wc and 14 in. wc.		
3. Field installed sensors installed. Refer to "Factory-Provided Sensors," p. 38 for list of sensors that may be required.		
4. Control wiring installed and landed.		
5. Accessories installed.		
6. Ductwork installed (all runs in place, final tie in complete).		
7. Drain lines installed and properly terminated.		
8. Startup appointment with Horizon certified Trane service technician set and confirmed.		
9. Test and Balance recommended prior to Start Up.		

Notes:

- Check list must be completed and returned to Trane before startup is scheduled.
- Startup must be performed by a Horizon-certified Trane technician with Tracer™ TU program.
- Contractor to furnish access to equipment (ladder, lift, or roof access).



System Configuration and Pre-Start

The following procedure must be completed prior to performing the startup procedure in “Startup,” p. 52. This section describes procedures to navigate the various displays on the Unit Display and configure the Outdoor Air Unit Main Unit Display system setpoints and operating parameters.

Important: This section is intended to provide guidelines for navigation through the remote operator display screens. For

additional control system information, refer to Integration Guide: Tracer™ UC600 Programmable Controller for Packaged Outdoor Air Unit (BAS-SVP18-EN). The unit is configured at the factory with the default settings as described in sequence of operation and the details concerning setup and operating setpoints.*

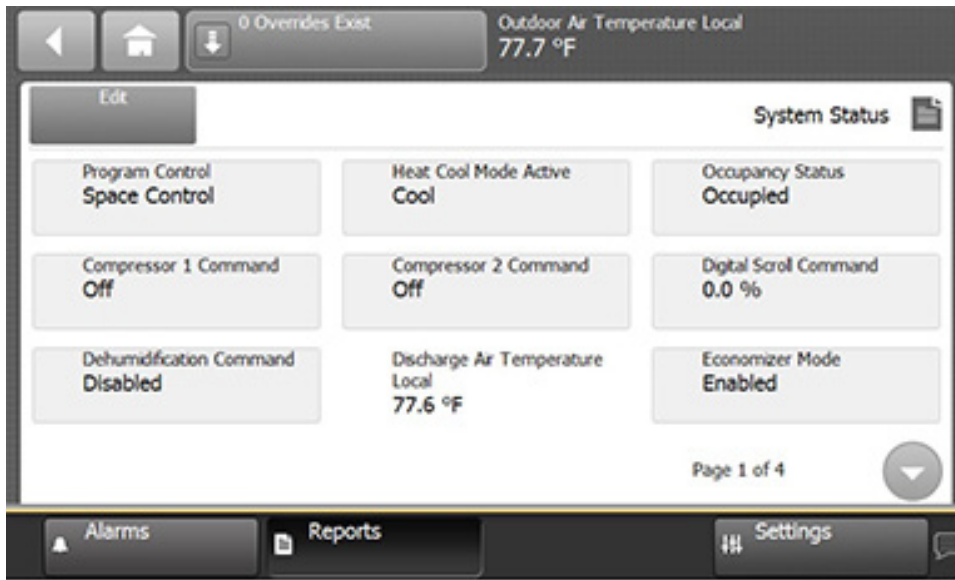

Table 8. Chart of analog and binary input/output

#	BACnet Point Name	Write	Default	Range	Units	Description
AI-01	Space Temperature Local			40–95	°F	Hardwired input from field installed space temperature sensor, wired to OAUTS-1 & -2 (SPTC).
AI-02	Space Humidity Local			0–100	%	Hardwired input from field installed space humidity sensor, wired to OAUTS-5 & -6 (SPHC).
AI-03	Supply Fan Piezo Pressure Local			0–25	in.H ₂ O	Hardwired input from factory installed piezo differential pressure sensor (SPZ).
AI-04	Outdoor Coil Leaving Temperature Circuit 1 Local			-50–270	°F	Hardwired input from factory installed temperature sensor located on the outdoor coil (CCTC1).
AI-05	Outdoor Coil Leaving Temperature Circuit 2 Local			-50–270	°F	Hardwired input from factory installed temperature sensor located on the outdoor coil (CCTC2).
AI-06	Return Air Temperature Local			-40–135	°F	Hardwired input from factory installed temperature sensor located in the return air path (RTC).
AI-07	Outdoor Air Damper Position Status Local			0-100	%	Hardwired input that provides feedback status from the actuator located on the outdoor air damper (OAD).
AI-08	Space CO ₂ Concentration Local			-	ppm	Hardwired input from field provided CO ₂ .

Table 8. Chart of analog and binary input/output (continued)

#	BACnet Point Name	Write	Default	Range	Units	Description
AI-09	Exhaust Fan Piezo Pressure Local			0–25	in.H ₂ O	Hardwired input from factory installed piezo differential pressure sensor (EPZ).
AI-10	Outdoor Air Flow Local			--	cfm	Hardwired input from factory outdoor air flow monitoring station (AMS).
AI-11	Discharge Air Temperature Local			-40–150	°F	Hardwired input from field installed discharge air temperature sensor wired to OAUTS-23 & -24 (DTC).
AI-12	Return Duct/Space Pressure Local			0–2	in.H ₂ O	Hardwired input from field installed transducer mounted in the return air duct (RDSPC).
AI-13	Exhaust Leaving Temperature Local			-40–130	°F	Hardwired input from factory installed temperature sensor located between the energy recovery wheel and the exhaust fan (EXTC).
AI-14	Return Air Humidity Local			0–100	%	Hardwired input from factory installed humidity sensor located in the return air path (RRHC).
AI-15	Indoor Coil Leaving Air Temperature Local			-40–160	°F	Hardwired input from factory installed temperature sensor located between the cooling and the hot gas reheat coils (ICTC).
AI-16	Suction Line Refrigerant Pressure Circuit 2 Local			0–150	psi	Hardwired input from factory installed pressure transducer on the refrigeration circuit (SLPC2).
AI-17	Energy Recovery Supply Air Leaving Temperature Local			-40–130	°F	Hardwired input from factory installed temperature sensor located between the energy recovery wheel and the indoor coil (ERSTC).
AI-18	Liquid Line Refrigerant Pressure Circuit 1 Local			0–500	psi	Hardwired input from factory installed pressure transducer on the refrigeration circuit (LLPC1).
AI-19	Liquid Line Refrigerant Pressure Circuit 2 Local			0–500	psi	Hardwired input from factory installed pressure transducer on the refrigeration circuit (LLPC2).
AI-20	Space Temperature Setpoint Local			55–85	°F	Hardwired input for field installed thumbwheel input wired to OAUTS-3 (VTSP).
AI-21	Outdoor Air Temperature Local			-40–130	°F	Hardwired input for factory installed temperature sensor reading outdoor air (OTC).
AI-22	Outdoor Air Relative Humidity Local			0–100	%	Hardwired input for factory installed humidity sensor reading outdoor air (ORHC).
AI-23	Duct Static Pressure Local			0–2	in.H ₂ O	Hardwired input for field installed supply duct static pressure wired to OAUTS-1 & -2 (SDPC).
AI-24	Exhaust/Return Pressure Differential Local			0–1	in.H ₂ O	Local pressure differential between return and exhaust.
AI-25	Preheat Leaving Coil Temperature Local			-58–350	°F	Local temperature sensor after the pre-heater.
AI-26	Mixed Air Temperature Local			-50–150	°F	Local averaged temperature sensor before entering the indoor coil.
AI-27	Discharge Air Humidity Local			0–105	%	Local discharge air humidity sensor.
AI-28	Suction Line Refrigerant Pressure Circuit 1 Local			0–150	psi	Hardwired input from factory installed pressure transducer on the refrigeration circuit (SLPC1).



System Configuration and Pre-Start

Table 8. Chart of analog and binary input/output (continued)

#	BACnet Point Name	Write	Default	Range	Units	Description
AO-01	Hot Gas Reheat Valve Command			0–100	%	Analog hot gas reheat output.
AO-02	Supply Fan Speed Command			0–100	%	Supply fan speed output.
AO-03	Compressor Speed Command Circuit 1			0–100	%	Speed control for circuit 1 digital scroll or variable speed compressor.
AO-04	Exhaust Fan Speed Output Command			0–100	%	Exhaust fan speed output
AO-05	Outdoor Air Damper Position Command			0–100	%	Position command for outdoor air damper. Return air damper position is inverse to this output.
AO-06	Energy Recovery Outdoor Air Bypass Position Command			0–100	%	Analog output for modulating ERV outdoor air bypass.
AO-07	Condenser Fan Speed Command			0–100	%	Analog condenser fan speed command.
AO-08	Compressor Speed Command Circuit 2			0–100	%	Speed control for circuit 1 digital scroll or variable speed compressor.
AO-09	Chilled Water Valve Command			0–100	%	Analog chilled water actuator valve output command.
AO-10	Energy Recovery Wheel Speed Command			0–100	%	Analog ERV VFD command.
AO-11	Heating Output Command			0–100	%	Analog heating output command. Modulating burner only for gas heat.
AO-12	Second Stage Condenser Fan Speed Command			0–100	%	Analog condenser fan speed command for the second stage.
AO-13	Energy Recovery Exhaust Air Bypass Position Command			0–100	%	Analog output for modulating ERV exhaust air bypass.
AV-01	Occupied Cooling Setpoint	•	72°F	55–85	°F	Space cooling setpoint used in occupied mode.
AV-02	Occupied Heating Setpoint	•	70°F	55–85	°F	Space heating setpoint used in occupied mode.
AV-04	Heat Pump Disable Temperature	•	25°F	0–60	°F	Heat pump operation is disabled when the outdoor air temperature falls below this setpoint.
AV-05	Dehumidification Temperature Active			-58–482	°F	Temperature reading for dehumidification. For OAN Rev. 6 cabinets this is discharge air dewpoint, all other it's indoor coil leaving temperature.
AV-07	Space Humidity Active			0–100	%	Actively used space relative humidity.
AV-08	Space Humidity BAS	•		0–100	%	Communicated space relative humidity. Takes priority over hardwired input when put In Service.
AV-10	Outdoor Air Dewpoint Enable Setpoint	•	55°F	45–100	°F	Setpoint used to put the unit into dehumidification.
AV-11	Outdoor Air Dewpoint			-10–150	°F	Dewpoint of the outdoor air. This point is calculated within the program.
AV-12	Exhaust Fan Tracking Offset Setpoint	•	0.9	0–150	%	Setpoint used to track with the supply fan speed. Factory default is Out of Service. When put In Service it takes priority over other exhaust fan control schemes.

Table 8. Chart of analog and binary input/output (continued)

#	BACnet Point Name	Write	Default	Range	Units	Description
AV-13	Supply Fan Air Flow Minimum Setpoint - Heating Mode		0	Varies	cfm	Setpoint used for supply fan during heating mode (not heat pump).
AV-14	Dehumidification Temperature Setpoint	•	46	40–75	°F	Setpoint used during dehumidification.
AV-16	Occupied Offset	•	2	0–18	Δ°F	Offset used to switch between modes of operation.
AV-17	Supply Fan Speed Setpoint	•	1	50–100	%	Setpoint used for constant speed supply fan.
AV-18	Compressor Heating Capacity			0–100	%	Compressor Heating source capacity.
AV-19	Damper Control P-Gain	•	4	0–16		P-Gain used for outdoor air damper operation.
AV-20	Space Temperature BAS			40–95	°F	Communicated space temperature. Takes priority over hardwired input when put In Service.
AV-21	Compressor Low Ambient Lockout	•	55°F	50–75	°F	Setpoint used to lock out compressor operation on units without head pressure control.
AV-23	Space Temperature Active			40–95	°F	Actively used space temperature.
AV-24	Discharge Air Dewpoint			-58–482	°F	Active discharge air dewpoint temperature.
AV-25	Space Temperature Setpoint BAS	•	72°F	62–80	°F	Communicated space temperature setpoint.
AV-26	Unoccupied Cooling Enable Setpoint	•	80°F	60–90	°F	Space cooling setpoint used in unoccupied mode.
AV-27	Unoccupied Heating Enable Setpoint	•	65°F	45–90	°F	Space heating setpoint used in unoccupied mode.
AV-28	Unoccupied Dewpoint Enable Setpoint	•	65°F	49–100	°F	If the space dewpoint rises above this setpoint during unoccupied mode then dehumidification will be enabled.
AV-29	Outdoor Air Cooling Enable Setpoint	•		45–100	°F	Setpoint used to lock the unit into cooling mode. User input with Discharge Control, calculated value on other units.
AV-30	Discharge Air Cooling Setpoint BAS	•	60°F	45–90	°F	Discharge air setpoint during cooling mode.
AV-32	Discharge Air Heating Setpoint BAS	•	65°F	45–100	°F	Discharge air setpoint during heating mode.
AV-33	Outdoor Air Heating Enable Setpoint	•		15–75	°F	Setpoint that puts the unit into heating mode. User input with Discharge Control, calculated value on other units.
AV-34	Calculated Space Dewpoint Setpoint		58°F	42–80	°F	Calculated setpoint using Space Temperature Setpoint Active and Space Humidity Setpoint. Puts the unit into dehumidification.
AV-35	Space Dewpoint			-500–482	°F	Actively used space dewpoint.
AV-37	Space Temperature Setpoint Active			45–95	°F	Actively used space temperature setpoint from Space Temperature Setpoint BAS, or from Occupied Cooling or Heating Setpoint based on mode.
AV-38	Outdoor Air Flow Active			0–25000	cfm	Actively used outside air flow.
AV-39	Supply Fan Air Flow Setpoint	•		0–25000	cfm	Setpoint used to control the supply fan for constant volume, or maximum limit for VAV units.
AV-40	Exhaust Fan Speed Setpoint BAS	•	0.8	0–100	%	Setpoint used for constant speed exhaust fan.



System Configuration and Pre-Start

Table 8. Chart of analog and binary input/output (continued)

#	BACnet Point Name	Write	Default	Range	Units	Description
AV-41	Supply Fan Air Flow Active			0–26000	cfm	Actively used supply airflow. Calculated using the supply fan piezo pressure.
AV-42	Space CO2 Concentration BAS	•			ppm	Communicated space CO2 conditions.
AV-43	Discharge Air Temperature Setpoint Minimum	•	50°F	40–65	°F	Setpoint used to limit the discharge air temperature reset.
AV-44	Heat Capacity			0–100	%	Primary heating source capacity.
AV-45	Discharge Air Temperature Setpoint Maximum	•	120°F	80–120	°F	Setpoint used to limit the discharge air temperature reset.
AV-46	Duct Static Pressure Setpoint BAS	•	1.5	-1–6	in.H ₂ O	Setpoint used to control supply fan to static pressure.
AV-47	Outdoor Air Damper Maximum Position Setpoint	•	1	0–100	%	Setpoint used to limit the outdoor air damper position during all operation.
AV-48	Outdoor Air Damper Minimum Position Setpoint	•		0–100	%	Setpoint used to limit the outdoor air damper position during all operation.
AV-50	Space CO2 Concentration Setpoint	•	500	0–3000	ppm	Setpoint used to control the outdoor air damper.
AV-51	Cool Control Pgain		4	0–12		Pgain used to control the compressors.
AV-52	Cooling Capacity			0–500	%	Active cooling capacity of the unit.
AV-54	Exhaust Fan Air Flow Active			0–26000	cfm	Actively used exhaust airflow. Calculated using the supply fan piezo pressure.
AV-55	Direct Fired Profile Width	•		6–28		Width of the profile opening for direct fired heaters. Used to calculate air flow.
AV-56	Return Duct/Space Pressure Setpoint	•	0.5	-1–3	in.H ₂ O	Setpoint used for exhaust fan static pressure control.
AV-57	Exhaust Fan Air Flow Setpoint	•		0–25000	cfm	Setpoint used for constant volume exhaust fan control.
AV-59	Supply Fan Air Flow Minimum Setpoint - Cooling Mode		0		cfm	Setpoint used for supply fan during cooling or heat pump operation.
AV-61	Heat Control Pgain	•	4	0–6		Pgain used to control primary heat.
AV-62	Space CO2 Concentration Active			0–10000	ppm	Actively used space CO2 conditions.
AV-63	Heat Pump Fail Switch Point			-58–482	°F	Outdoor air temperature at which the heat pump failed to meet setpoint.
AV-64	Duct Static Pressure BAS	•		-6–6	in.H ₂ O	Communicated duct static pressure. Factory defaulted Out of Service. When put In Service it takes priority over hardwired input.
AV-65	Duct Static Pressure Active			-6–6	in.H ₂ O	Actively used duct static pressure.
AV-66	Discharge Air Temperature Setpoint Active			38–130	°F	Actively used discharge air temperature setpoint. For Space Control and Single Zone VAV this is reset within the program.
AV-67	Discharge Air Temperature Setpoint BAS	•	55°F	40–125	°F	Communicated discharge air temperature setpoint. Factory default Out of Service. When put In Service it replaces Discharge Air Cooling and Heating Setpoints.

Table 8. Chart of analog and binary input/output (continued)

#	BACnet Point Name	Write	Default	Range	Units	Description
AV-68	Outdoor Air Enthalpy Active				BTU/lb	Actively used outdoor air enthalpy.
AV-71	Outdoor Air Flow Setpoint BAS	•		0–25000	cfm	Setpoint to modulate the dampers.
AV-72	Return Air Enthalpy Active				BTU/lb	Actively used outdoor air enthalpy.
AV-74	Supply Fan Air Flow Minimum Setpoint Active			0–25000	cfm	Actively used setpoint. Controlled by program from minimum setpoints for heating and cooling mode.
AV-75	Outdoor Air Temperature BAS	•		-40–135	°F	Optional communicated outdoor air temperature.
AV-76	Outdoor Air Temperature Active			-100–200	°F	Actively used outdoor air temperature.
AV-77	Dehumidification Temperature Setpoint Active		48°F	38–75	°F	Actively used setpoint during dehumidification.
AV-81	Outdoor Air Humidity BAS	•	0.5	0-100	%	Optional communicated outdoor air relative humidity.
AV-82	Outdoor Air Humidity Active		0.45	0-100	%	Actively used outdoor air relative humidity.
AV-87	Space Humidity Setpoint	•	0.45	0–100	%	Setpoint used to calculate Space Dewpoint Setpoint.
AV-88	Condenser Fan P-Gain	•	4	0–10		Pgain used to control condenser fans
BI-01	Supply Fan Status			0=Off 1=On		Status of the supply fan using a differential pressure switch.
BI-02	Emergency Stop			0=Normal 1=ESTOP		Auto Reset. Shuts the unit down.
BI-03	Final Filter Status			0=Clean 1=Clogged		Auto Reset. Notification when differential pressure switch closes (adj. range) for the filters in front of the indoor coil.
BI-04	Occupancy Input			0=Unocc. 1=Occupied		Dry contact input for Occupancy Status. Wired to field wiring terminal strip OAUTS-7 & 8. To use MV-01 keep factory installed jumper in place.
BI-05	Outdoor Air Damper End Switch			0=Not Proven 1=Proven		End switch for outdoor air damper.
BI-06	Heat On Off Status Local			0=Off 1=On		Auto Reset (4 hours). Occurs when there is a call for heat but the heat status relay is not energized. The heat is cycled three times and then locked out for four hours before retrying.
BI-07	Exhaust Damper End Switch			0=Not Proven 1=Proven		End switch for isolation dampers for the exhaust fan.
BI-08	Outdoor Coil Water Flow Status			0=Off 1=On		Water flow status for outdoor water coil using a differential pressure switch.
BI-09	Outdoor Coil Water Low Temperature Switch			0=Open 1=Closed		Low temperature safety switch for outdoor water coil.
BI-10	Condensate Detection Input			0=Normal 1=InAlarm		Auto Reset.
BI-11	Indoor Coil Froststat			0=Clean 1=Frost		Auto Reset.



System Configuration and Pre-Start

Table 8. Chart of analog and binary input/output (continued)

#	BACnet Point Name	Write	Default	Range	Units	Description
BI-12	Energy Recovery Wheel Outdoor Air Filter Status			0=Clean 1=Clogged		Auto Reset. Notification when differential pressure switch closes (adj. range) for the filters before ERV on outdoor air side.
BI-13	Energy Recovery Wheel Return Air Filter Status			0=Clean 1=Clogged		Auto Reset. Notification when differential pressure switch closes (adj. range) for the filters before ERV on return air side.
BI-14	Exhaust Fan Status			0=Off 1=On		Status of the exhaust fan using a differential pressure switch.
BI-15	Energy Recovery Wheel Rotation Status			0=Off 1=On		Status of the energy recovery wheel using a proximity sensor.
BI-16	Hot Water Freezestat			0=Normal 1=Freezing		Manual Reset. Shuts the unit down.
BI-17	Compressor 1 Status			0=On 1=Off		Feedback run status hardwired through compressor contactor.
BI-18	Compressor 2 Status			0=On 1=Off		Feedback run status hardwired through compressor contactor.
BI-19	Compressor 3 Status			0=On 1=Off		Feedback run status hardwired through compressor contactor.
BI-20	Compressor 4 Status			0=On 1=Off		Feedback run status hardwired through compressor contactor.
BI-21	Compressor 5 Status			0=On 1=Off		Feedback run status hardwired through compressor contactor.
BI-22	Compressor 6 Status			0=On 1=Off		Feedback run status hardwired through compressor contactor.
BI-23	Compressor 1 VFD Status			0=Alarm 1=Normal		Compressor alarm status input from VFD.
BO-01	Supply Fan Start Stop Command			0=Off 1=On		Enable for supply fan.
BO-02	Outdoor Air Damper Open Close Command			0=Open 1=Closed		Enable for outdoor air damper.
BO-03	Heat 1 Command			0=Off 1=On		Enable for stage 1 of the primary heater.
BO-04	Inducer Command			0=Off 1=On		Output to switch stage 1 inducer fan from low to high speed.
BO-05	Compressor 3 Command			0=Off 1=On		Enable for compressor 3.
BO-06	Compressor 4 Command			0=Off 1=On		Enable for compressor 4.
BO-07	Heat 2 Command			0=Off 1=On		Enable for stage 2 heat.
BO-08	Heat 3 Command			0=Off 1=On		Enable for stage 3 heat.
BO-09	Exhaust Damper Open Close Command			0=Open 1=Closed		Output to open isolation dampers located on exhaust fan.
BO-10	Exhaust Fan Start Stop Command			0=Off 1=On		Enable for exhaust fan.
BO-11	Compressor 1 Command			0=Off 1=On		Enable for compressor 1.

Table 8. Chart of analog and binary input/output (continued)

#	BACnet Point Name	Write	Default	Range	Units	Description
BO-12	Compressor 2 Command			0=Off 1=On		Enable for compressor 2.
BO-13	Pre-Heat Enable			0=Off 1=On		Enable for electric pre-heat located in front of energy recovery wheel.
BO-14	Condenser Fan Start Stop Command			0=Off 1=On		Enable for condenser fan(s).
BO-15	Energy Recovery Wheel Start Stop Command			0=Off 1=On		Enable for energy recovery wheel.
BO-16	Circuit 1 Reversing Valve Command			0=Heating 1=Cooling		Output used to switch between heat pump and cooling on circuit 1.
BO-17	Circuit 2 Reversing Valve Command			0=Heating 1=Cooling		Output used to switch between heat pump and cooling on circuit 2.
BO-18	Split Exhaust-Return Damper Open Close Command			0=Open 1=Closed		Output to open damper located between split exhaust and return air paths.
BO-19	Compressor 1 VFD Reset			0=Off 1=Reset		Output to reset compressor VFD when it goes into alarm.
BO-20	Second Stage Condenser Fan Start Stop Command			0=Off 1=On		Output to enable second stage of condenser fans.
BO-21	Compressor 5 Command			0=Off 1=On		Enable for compressor 5.
BO-22	Compressor 6 Command			0=Off 1=On		Enable for compressor 6.
BV-04	Heat Pump Defrost Mode			0=Off 1=On		Defrost status for outdoor coil.
BV-05	Hot Gas Reheat Purge Mode			0=Off 1=On		Purge status for hot gas reheat.
BV-07	Auxiliary Heating Mode			0=Allowed 1=Not Allowed		Used to interlock primary heater to prevent simultaneous heat pump and primary heat operation.
BV-09	Economizer Status			0=Not Econ. 1=Econ.		Economizer status.
BV-16	Alarm Reset			0=Normal 1=Reset		Used to reset all manual reset diagnostics.
BV-17	System LOCKOUT			0=Normal 1=Lockout		Generic diagnostic accompanying diagnostics that require manual reset.
BV-18	Exhaust Fan Static Pressure Control Direction	•	Reverse	0=Reverse 1=Direct		Used to switch the exhaust fan PID for static pressure control between direct and reverse acting.
BV-20	Allow Unoccupied Operation	•	#N/A	0=Not Allowed 1=Allowed		Toggles unoccupied operation.
BV-21	Heat Cool Mode Active			0=Heat 1=Cool		Heat/cool mode status used throughout the program.
BV-23	Unoccupied Cooling Mode			0=Disabled 1=Enabled		Active status on operation in unoccupied cooling mode.
BV-25	Circuit 1 Status			0=Off 1=On		Feedback status on the circuit 1 refrigeration.
BV-27	Dehumidification Status			0=Off 1=On		Active status on operation in dehumidification mode.
BV-39	Unoccupied Heating Mode			0=Off 1=On		Heat mode status during unoccupied.



System Configuration and Pre-Start

Table 8. Chart of analog and binary input/output (continued)

#	BACnet Point Name	Write	Default	Range	Units	Description
BV-40	Unoccupied Dehumid Mode			0=Off 1=On		Dehumidification mode status during unoccupied.
BV-41	Energy Recovery Frost Avoidance Status			0=Normal 1=Active		Status indicating when actively bypassing or slowing down energy recovery wheel to prevent frost accumulation.
BV-43	Ventilation Mode			0=Off 1=On		Status for ventilation mode, locking out heating and cooling.
BV-44	Free Cooling Mode			0=Off 1=On		Status for free cooling mode, using outdoor air temperature to maintain setpoint.
BV-45	Economizer Control Type	•	Enthalpy	0=DryBulb 1=Enthalpy		Used to switching between dry bulb or enthalpy economizer.
BV-49	Mixed Air Low Limit Active			0=Normal 1=Active		Auto-Reset:
BV-57	Defrost Mode Heat Enable			0=Off 1=On		Status indicating supplemental heat during outdoor coil defrost mode.
BV-61	Compressor Heating Allowed			0=Allowed 1=Not Allowed		Active status on whether heat pump is allowed.
BV-62	Compressor Cooling Allowed			0=Allowed 1=Not Allowed		Active status on whether cooling is allowed.
BV-63	Circuit 2 Status			0=Off 1=On		Feedback status on the circuit 1 refrigeration.
BV-64	Compressor Low Ambient Lockout Active			0=Active 1=Not Active		Status indicating that the unit is calling for cooling but the compressors are locked out due to low ambient temperature.
MV-01	Occupancy Request	•				1 = Occupied 2 = Unoccupied 3 = Occupied Bypass 4 = Occupied Standby 5 = Auto
MV-02	Occupancy Status					1 = Occupied 2 = Unoccupied 3 = Occupied Bypass 4 = Occupied Standby
MV-03	Heat Cool Mode Request	•				1 = Auto 2 = Heat 3 = Morning Warm-up 4 = Cool 7 = Off 10 = Fan Only 11 = Economizing 15 = Dehumidify
MV-04	Heat Cool Mode Status					See Heat Cool Mode Request (MV-03)
MV-05	Discharge Air Temperature Setpoint Source Status					1 = Discharge Air Cooling Setpoint BAS 2 = Discharge Air Heating Setpoint BAS 3 = Discharge Air Temperature Setpoint BAS 4 = Reset for Space Comfort Control
MV-06	Emergency Override BAS	•	1			1 = Normal 6 = Fire
MV-07	Space Temperature Setpoint Source Status					1 = Occupied Heating Setpoint 2 = Occupied Cooling Setpoint 3 = Thumbwheel (Space Temperature Setpoint Local) 4 = Space Temperature Setpoint BAS
MV-08	Dehumidification Temperature Source Status					1 = Discharge Air Dewpoint 2 = Indoor Coil Leaving Temperature
MV-09	Heat Type		-			Factory set heat type.

Table 8. Chart of analog and binary input/output (continued)

#	BACnet Point Name	Write	Default	Range	Units	Description
MV-10	Supply Fan Wheel Size		–			Factory set supply fan size.
MV-11	Direct Fired Burner Size		–			Factory set direct fired burner size.
MV-12	Exhaust Fan Wheel Size		–			Factory set exhaust fan size.
MV-13	Program Control Type	•	#N/A			1 = Space Control 2 = Discharge Control 3 = Single Zone VAV 4 = Multi Zone VAV 5 = Critical Space Control 6 = Critical Discharge Control
MV-16	Dehumidification System Status					1 = Off 2 = On
MV-17	Economizer System Status					1 = Not Economizing 2 = Economizer Mode 3 = Free Cooling Mode 4 = Ventilation Mode
MV-19	Compressor 1 Status Active					1 = Disabled 2 = Enabled, No Running Status 3 = Enabled With Running Status 4 = Enabled, No VFD Alarm 5 = Not Installed
MV-20	Compressor 2 Status Active					1 = Disabled 2 = Enabled, No Running Status 3 = Enabled With Running Status 4 = Not Installed 5 = Input Status In Fail
MV-21	Compressor 3 Status Active					See Compressor 2 Status Active MV-20
MV-23	Compressor 4 Status Active					See Compressor 2 Status Active MV-20
MV-24	Compressor 5 Status Active					See Compressor 2 Status Active MV-20
MV-25	Compressor 6 Status Active					See Compressor 2 Status Active MV-20

Pre-Start Up

Start Up

1. Perform Test and Balance before start up (if possible).
2. Set up Date and Time for unit, helps with diagnosis when looking at alarms and data logs.
3. Check points of interest sheet and confirm in/out of service points.
4. Verify Phase Monitor.
 - a. Check voltage.
 - b. Check Phase imbalance set to 2-3%.
 - c. Restart is set halfway between 1 to 125 seconds.
 - d. Check Trip delay is set at 30 seconds.
 - e. ESR 1/2/3 should be lit if phase monitor.
5. Check UC600 Setpoints.
 - a. Duct Static Pressure setpoint.
 - b. Minimum OA Damper position.
 - c. Maximum OA Damper position.
 - d. Supply Air Flow Setpoint.
 - e. Exhaust Air Flow Setpoint.
 - f. IVFD signal.
 - g. PEVFD Setpoint.
6. Identify Airflow Monitoring.
 - a. Zero out Piezo(s) before startup if applicable.
 - i. Detach clear tubing from sensor.
 - ii. Remove sensor cover.
 - iii. Press and hold the ZERO button.
 - iv. Display should read 0.00.
 - v. Put the cover back on.
 - vi. Recalibrate in TU UC600.
 - vii. Click on Supply Fan pressure if the number is not 0, right click to configure.
 - viii. Make calibration offset the opposite of the number listed as supply fan pressure.
 - ix. For example, if the supply fan pressure is listed as 0.18, set the calibration offset to -0.18 and save.

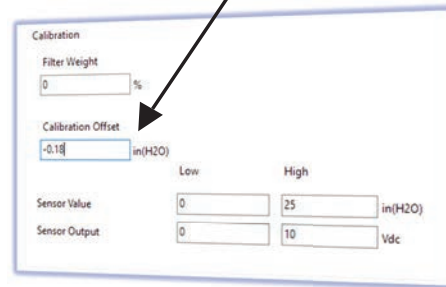
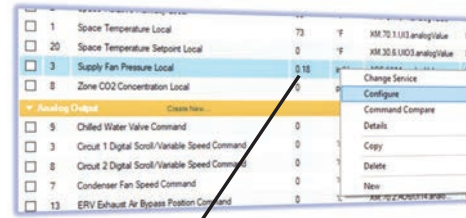

- x. Reattach the clear tubing to the sensor securely.
- xi. Repeat for Exhaust Piezo if applicable.

7. Identify OA/RA Dampers.
 - a. Verify end switch is set to 4.

Cooling Start Up

Important: This should NOT be performed if ambient temperatures are <65°F or >105°F.

1. Check Supply Fan RPM and Hz settings.
2. Identify Compressor type.
 - a. If model number begins with:
 - i. ZP- Fixed Speed (one or both circuits).
 - ii. ZPD- Digital Compressor (one or both circuits).
 - iii. ZPV- Variable Speed Compressor (1st circuit only).
3. For Fixed/Digital Compressors:
 - a. Override compressor 1 ON, or compressor 1 and 2 ON in a tandem circuit.
 - b. For digital scroll, override Circuit 1 command to 100%.
 - c. Override HGRH to 25%.
 - d. Raise head pressure to 400 psi.
 - e. Record electrical data, refrigerant pressures, saturated temps and line temps on Horizon. Start Up sheet (available at the end of this document).
 - f. Override HGRH 100% and check refrigerant flow.
 - g. Override Compressor OFF.
 - h. Repeat Circuit 2 (if applicable) Variable Speed Compressor.
4. Variable Speed Compressor.
 - a. Override Compressor 1 ON.

- b. Override Circuit 1 to 0%.
- c. Override HGRH to 100%.
- d. Maintain head pressure 400 psi.
- e. Record electrical data, refrigerant pressures, saturated temps and line temps on Horizon. Start Up sheet (available at the end of this document).



Startup

Indirect Fired Gas Heating Startup

⚠ WARNING

Hazardous Service Procedures!

Failure to follow all precautions in this manual and on the tags, stickers, and labels could result in death or serious injury.

- Technicians, in order to protect themselves from potential electrical, mechanical, and chemical hazards, **MUST** follow precautions in this manual and on the tags, stickers, and labels, as well as the following instructions: Unless specified otherwise, disconnect all electrical power including remote disconnect and discharge all energy storing devices such as capacitors before servicing. Follow proper lockout/tagout procedures to ensure the power can not be inadvertently energized. When necessary to work with live electrical components, have a qualified licensed electrician or other individual who has been trained in handling live electrical components perform these tasks.
- Do not attempt the following procedures until all electrical and gas connections to the unit have been completed and the outdoor air damper and evaporator fan operation have been verified and are operating correctly.

⚠ AVERTISSEMENT

Procédures d'entretien dangereuses!

Le non-respect de toutes les précautions contenues dans ce manuel ainsi que sur les étiquettes et les autocollants peut entraîner des blessures graves voire mortelles.

- Les techniciens, afin d'être protégés des éventuels risques électriques, mécaniques et chimiques, **DOIVENT** suivre les précautions contenues dans ce manuel, sur les étiquettes et les autocollants, ainsi que les instructions suivantes : Sauf indication contraire, coupez toute l'alimentation électrique y compris les disjoncteurs à distance et déchargez tous les dispositifs de stockage d'énergie comme les condensateurs avant l'entretien. Respectez les procédures de verrouillage et d'étiquetage appropriées pour éviter tout risque de remise sous tension accidentelle. S'il est nécessaire de travailler avec des composants électriques sous tension, demandez à un électricien qualifié et agréé ou à une autre personne ayant la formation nécessaire pour manipuler des composants électriques sous tension d'exécuter ces tâches.
- N'essayez pas de réaliser les procédures suivantes avant d'avoir effectué tous les raccordements en gaz et électricité sur l'unité, d'avoir inspecté le registre d'air extérieur et le ventilateur d'évaporateur et confirmé que leur fonctionnement est approprié.

Notes:

1. This furnace module does not have a pilot. It is equipped with a direct spark ignition device that automatically lights the gas burner. **DO NOT** try to light burners by hand.

⚠ WARNING

Hazard of Explosion!

Failure to follow proper safe leak test procedures could result in death or serious injury or equipment or property-only-damage. **NEVER** use an open flame to detect gas leaks. You **MUST** use a leak test solution for leak testing.

⚠ AVERTISSEMENT

Risque d'explosion!

Le non-respect des procédures d'essai d'étanchéité sûres recommandées pourrait provoquer des accidents graves, voire mortels, ou des dommages matériels. Ne vérifiez **JAMAIS** la présence de fuites de gaz avec une flamme nue. Vous devez **IMPÉRATIVEMENT** utiliser une solution de test d'étanchéité pour vérifier l'étanchéité.

2. BEFORE OPERATING, leak test all gas piping up to heater gas valve. Smell around the unit area for gas. If gas is smelled, do NOT attempt to place heater in operation until source of gas leak is identified and corrected.
3. Use only hand force to operate the gas control lever to the "ON" position. NEVER use tools. If lever does not operate by hand, replace gas valve prior to starting the unit. Forcing or attempting to repair the gas valve may result in fire or explosion.
4. Do not attempt to operate unit, if there is indication that any part or control has been under water. Any control or component that has been under water must be replaced prior to trying to start the unit.

Tools Required

- Voltage Meter (μ A)
- Amp Meter
- Gas Manometer (2)
- Temperature Probe
- Small Refrigeration Screwdriver
- 5/16-in. Nut Driver
- 3/16-in. Allen Wrench
- 3/32-in. Allen Wrench
- 1/8-in. NPT barbed pressure taps (3)
- 1/2-in. Open End Wrench

Startup Procedure

1. Check Inlet Gas Pressure

Check to insure the gas pressure supplied to the unit is within the pressure requirement listed on the nameplate. DO NOT expose gas controls to pressures above 1/2 psi (14 in. WC). The gas supply line should be installed with an external manual shutoff and pressure tap.

2. Verify Indoor Fan Failure Switch Operation

Indoor Fan Failure Switch (IFFS) is located in the unit electrical control compartment above the heater. Indoor fan failure switch will fail if not proven within 30 seconds of call for indoor fan—ON.

All unit air filters must be clean before proceeding to properly complete this verification.

Verify Indoor Fan Failure Switch (OAB, or OAG cabinets with UC600 controls)

- a. The minimum of Analog Values labelled Supply Fan Air Flow Minimum Setpoint is Cooling Mode (AV59) and Supply Fan Air Flow Minimum Setpoint is Heating Mode (AV13).
- b. Override Analog Output labelled Supply Fan Speed Command (AO2) until the Supply Fan Air Flow Active (AV41) matches the value from step 1.
- c. Locate the Indoor Fan Failure Switch (IFFS) in the control section. Labelled IFFS or two red wires labelled IFFS/464A.

- d. Slowly rotate IFFS switch clockwise (lightly tapping the IFFS after each full turn) until IFFR relay is not lit.
- e. Rotate IFFS switch 1/2 turn counterclockwise. IFFR relay should then be lit.
- f. Release Supply Fan Speed Command.

Verify Indoor Fan Failure Switch (OAD, OAK or OAN cabinets with UC600 controls and all units without UC600)

- a. Set the unit at minimum air flow:
 - i. For OAD, OAK or OAN with UC600, override Supply Fan Speed Command to 0%.
 - ii. For all Units without UC600, have the controls contractor set the supply fan speed so that the air flow is at minimum.
- b. Locate the Indoor Fan Failure Switch (IFFS) in the control section. Labelled IFFS or two red wires labelled IFFS/464A.
- c. Slowly rotate IFFS switch clockwise (lightly tapping the IFFS after each full turn) until IFFR relay is not lit.
- d. Rotate IFFS switch 1/2 turn counterclockwise. IFFR relay should then be lit.
- e. Release Supply Fan Speed Command override.

Important: *If the unit air filters are not clean, unit performance could be affected. Remove and clean or replace air filters as required prior to proceeding with the burner pressure testing.*

In the event that the pressure switch fails to operate, check the pick-up tubes to be certain that the tubes are not obstructed and confirm that the tube connections to IFFS are tight and secure.

3. Confirm Gas Flow at Unit

⚠ WARNING

Hazardous Voltage and Gas!

Failure to turn off gas or disconnect power before servicing could result in an explosion or electrocution which could result in death or serious injury. Turn off the gas supply and disconnect all electric power, including remote disconnects, before servicing the unit. Follow proper lockout/tagout procedures to ensure the power can not be inadvertently energized.

⚠ AVERTISSEMENT

Tension dangereuse et présence de gaz!

Le non-respect de l'obligation de couper le gaz ou l'alimentation électrique avant de procéder à une opération d'entretien peut entraîner une explosion ou une électrocution pouvant résulter en des blessures graves, voire mortelles. Avant toute intervention sur l'unité, couper l'approvisionnement en gaz et l'ensemble de l'alimentation électrique, y compris les disjoncteurs à distance. Suivez scrupuleusement les procédures de verrouillage/mise hors service préconisées pour empêcher tout rétablissement accidentel de l'alimentation électrique.

Open door to unit vestibule housing the gas heater. Move gas control lever to "OFF" position. Remove 1/8-in. pressure taps (see [Figure 42, p. 56](#)) from both modulating and on-off sections of the split heater manifold. Install a barbed fitting in both 1/8-in. tapped holes for connection to individual gas manometers.

Note: *There is a third 1/8-in. gas pressure tap located in the pipe connecting the main valve/regulator and modulating valve. Maximum pressure into modulating valve is 5-in. The On-Off gas valve includes a regulator adjustment device that is located on the top of the valve. Use this device to regulate valve output to modulating valve as required.*

Wait 5 minutes for any gas to clear. If you smell gas, see [Step 2](#) and correct leak. If you don't smell gas or have corrected any leaks, go to [Step 4](#).

4. Burner Starting Sequence and Burner Ignition

[Figure 42, p. 56](#) illustrates indirect fired gas furnace components.

5. Main Gas Supply

Turn manual gas cock "ON".

6. Split Manifold High Fire and Burner Test

Open all manual gas valves. Turn power on at unit's main disconnect switch. Open gas supply manual shut-off valve. Using unit display (or computer with Trane Tracer TU), proceed to System Status Display and Override all Compressor stages OFF, Disable Dehumidification, Disable Economizer Mode, Disable

ERV. If two heaters are installed, test heating with split manifold first by overriding burner 2 OFF. Override heating Output Command to 100.0 percent if one heater is installed and to 49 percent if two heaters are installed. Override Heat Cool Mode Active to Heat. This will enable call for heat to split manifold heater. Depending on outdoor air temperature, at time of startup, heater high limit temperature may be exceeded causing limit switch to trip. Limit switch is auto-reset. Limit switch must be jumpered out of the circuit if OA temperature dictates.

With limit switch closed, the draft inducer will run on high speed for 10 seconds for proof of high and low airflow switch closure, then begin a 30-second pre-purge period. At the end of the pre-purge the direct spark will be energized and On-Off gas valve will open for a 5-second ignition trial. Following successful ignition, the inducer remains on high for 10-second flame stabilization, followed by 30-second warm up. Should the flame go out or the burner fail to light, an ignition retry will initiate following a 15-second inter-purge period.

Following successful ignition, manifold pressure should be 1.2 in. WC during the warm-up period. The manifold pressure will rise to 3.5 in. WC at 100 percent firing rate. Following these sequences to check low fire gas pressure for modulating section, reduce Heating Output Command to 0 percent. Inducer speed will reduce to low speed. Correct gas pressure for modulating manifold section of heater at 0 percent output signal or low fire will be 0.4 in. WC. For modulating sections, the outlet gas pressure from main/regulator valve into the modulating valve is 5-in. WC.

Main On-Off valves in 1/2-in. gas line require 3/32-in. Allen wrench to adjust outlet gas pressure. Valves in 3/4-in. gas line require flat blade screwdriver to adjust outlet gas pressure. Following these sequences, inducer speed will reduce to low speed and will now be speed-controlled by the heater controller based on gas input to burners.

With heating command at 100 percent and with a single split manifold heater installed, the On-Off section of the heater will require the modulating section to prove ON before the On-Off section will enable. Inducer speed high at all times the On-Off section is in ignition sequence or firing. On-Off section sequence includes a 1-second ignition pre-purge followed by 4-second ignition trial. Ignition or flame failure will be followed by 30-second inter-purge for two ignition retry then 5-minute lockout period if both retry attempts fail. Correct manifold gas pressure for On-Off heater section is 3.5 in. WC.

For units including an additional separate On-Off heater, set heat command output to 49 percent to run modulating heater startup. When complete with modulating heater startup, increase heat output command to 100 percent to start up the second heater.

High Fire and Low Fire Adjustment

To adjust high fire or low fire setting, please refer to EXA STAR Modulating Valve document. This document will ship with all gas heat units.

Failure to Ignite

- On the initial startup, or after unit has been off long periods of time, the first ignition trial may be unsuccessful due to need to purge air from manifold at startup.
- If ignition does not occur on the first trial, the gas and spark are shut-off by the ignition control and the control enters an inter-purge period of 15 seconds, during which the draft inducer continues to run.
- At the end of the inter-purge period, another trial for ignition will be initiated.
- Control will initiate up to three ignition trials on a call for heat before lockout of control occurs.
- Control can be brought out of lockout by cycling call for heat at the Main Unit Display.

Prior to completing the startup, check the appearance of the main burner flame. Refer to [Figure 41, p. 55](#) for flame characteristics of properly adjusted natural gas systems.

Pressure Settings		
Fuel Type	NG	LP
Unit Inlet (in.)	7-14	10-14
Modulating Valve Inlet (in.)	5.0	10.0
Manifold (in.)	3.5	8.0
Low Fire (in.)	0.4	0.8
High Fire (in.)	3.5	8.0

Figure 41. Flame characteristics of properly-adjusted natural gas systems

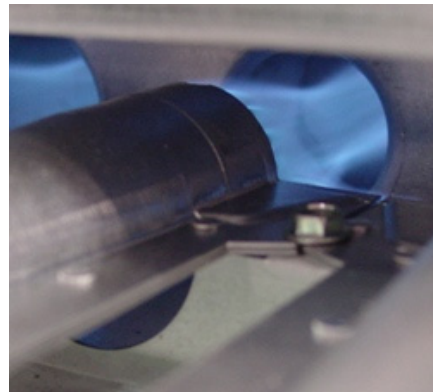

Burner flame at startup: 1.2 in. WC manifold pressure draft inducer—high speed

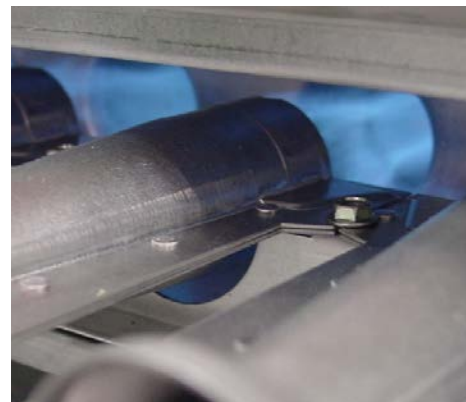

Burner flame at high fire: 3.5 in. WC manifold pressure draft inducer—high speed

Main burner flame

- The burner flame should be predominately blue in color and well defined and centered at the tube entry as shown in [Figure 41](#) above. Distorted flame or yellow tipping of natural gas flame, or a long yellow flame on propane, may be caused by lint and dirt accumulation inside burner or at burner ports, at air inlet between burner and manifold pipe, or debris in the main burner orifice. Soft brush or vacuum clean affected areas.
- Poorly defined, substantially yellow flames, or flames that appear lazy, indicate poor air supply to burners or excessive burner input. Verify gas supply type and manifold pressure with rating plate.
- Poor air supply can be caused by obstructions or blockage in heat exchanger tubes or vent discharge pipe. Inspect and clean as necessary to eliminate blockage. Vacuum any dirt or loose debris. Clean heat exchanger tubes with stiff brush. Poor flame characteristics can also be caused by flue gas recirculation into combustion air supply. If

Startup

surrounding buildings or prevailing winds cause recirculation, a flue extension may be required to prevent recirculation. Contact manufacturer prior to making any flue adjustments.

- Reduced air delivery can also be the result of inducer fan blade slippage, dirt accumulation in the fan blade or low voltage to draft inducer motor. Inspect draft fan assembly and be sure fan blade is secure to motor shaft. Check line voltage to heater.

7. Flame Sensor Current Check

NOTICE

Meter Damage!

Measuring voltage with meter connect to a circuit could result in meter damage. Do NOT measure voltage with meter connected to a circuit.

Flame current is the current which passes through the flame from the sensor to ground. A flame signal of 0.5 to 1.0 microamp (μA) is marginal. For dependable operation, a flame signal of greater than 1.0 μA is required. To measure flame current, connect a meter capable of reading micro-amp current so the flame signal will be read thru the meter's COM and μA connections. The meter should read greater than 1.0 μA .

Note: If the meter reads below "0" on scale, meter leads are reversed; disconnect power and reconnect meter leads for proper polarity.

Figure 42. Indirect fired gas furnace components

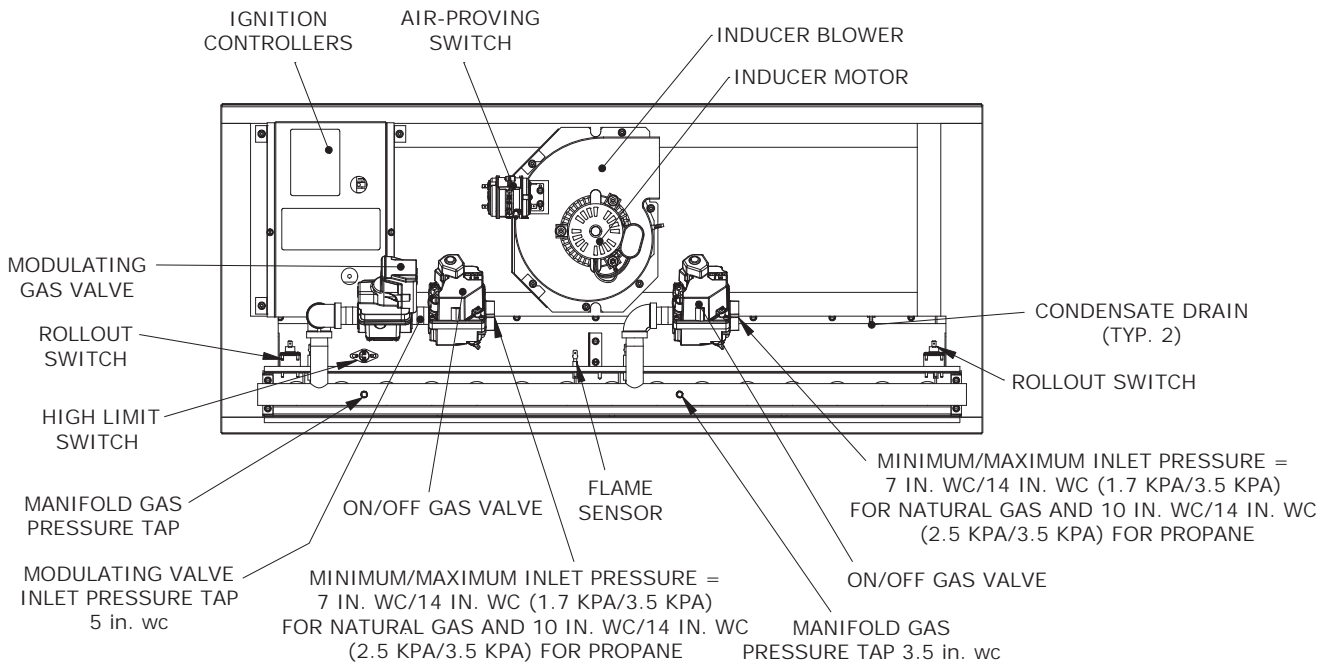

Safety Controls

Air Pressure Switch.

An air pressure switch is provided as part of the control system to verify airflow through draft inducer by monitoring the difference in pressure between the draft inducer and the atmosphere. If sufficient negative pressure is not present, indicating lack of proper air movement through heat exchanger, the switch opens shutting off gas supply through the ignition control module. On units with two speed draft inducer operation, a dual air pressure switch is used, monitoring high and low speed pressures. The air pressure switches have fixed settings and are not adjustable.

Rollout Switch (Manual Reset).

The furnace module is equipped with manual reset rollout switch(es) in the event of burner flame rollout. The switch will open on temperature rise and shut-off gas supply through the ignition control module. Flame rollout can be caused by insufficient airflow for the burner firing rate (high gas pressure), blockage of the vent system or in the heat exchanger. The furnace module should not be placed back in operation until the cause of rollout condition is identified and corrected. The rollout switch can be reset by pressing the button on top of the switch.

High Limit Switch.

The furnace module is equipped with a fixed temperature high limit switch mounted on the vestibule panel that shuts off gas to the heater through the ignition control module in the event of reduced airflow over the heat exchanger tubes. Reduced airflow can be caused by indoor fan failure, dirty or blocked filters, or restriction of the air inlet or outlet to the unit. The high limit switch will automatically reset when the air temperature drops to approximately 30°F below the limit setpoint. Determine the cause of the reduced air flow and correct.



Maintenance

Make sure all personnel are standing clear of the unit before proceeding. The system components will start when the power is applied.

Monthly Maintenance

Before completing the following checks, turn the unit OFF and lock the main power disconnect switch open.

⚠ WARNING

Hazardous Voltage!

Failure to disconnect power before servicing could result in death or serious injury. Disconnect all electric power, including remote disconnects before servicing. Follow proper lockout/tagout procedures to ensure the power can not be inadvertently energized.

⚠ AVERTISSEMENT

Risque d'électrocution!

Le non-respect de cette consigne peut entraîner des blessures graves, voire mortelles. Avant toute intervention, coupez l'alimentation électrique, y compris aux sectionneurs à distance. Suivez scrupuleusement les procédures de verrouillage/mise hors service préconisées pour empêcher tout rétablissement accidentel de l'alimentation électrique.

Filters

- Inspect the return air filters. Clean or replace them if necessary. Refer to the unit Service Facts for filter information and refer to "OAU Filter Guide" in "Appendix," p. 73 for exact replacement dimensions.

Supply/Return Air Smoke Detector Maintenance

Airflow through the unit is affected by the amount of dirt and debris accumulated on the indoor coil and filters.

To insure that airflow through the unit is adequate for proper sampling by the return air smoke detector, complete adherence to the maintenance procedures, including recommended intervals between filter changes, and coil cleaning is required.

Periodic checks and maintenance procedures must be performed on the smoke detector to insure that it will function properly.

For detailed instructions concerning these checks and procedures, refer to the appropriate section(s) of the smoke detector Installation and Maintenance Instructions provided with the literature package for this unit.

Cooling Season

- Check the unit's drain pans and condensate piping to ensure that there are no blockages.

- Inspect the evaporator and condenser coils for dirt, bent fins, etc. If the coils appear dirty, clean them according to the instructions described in "Condenser Coil Cleaning," p. 58.
- Manually rotate the condenser fan(s) to ensure free movement and check motor bearings for wear. Verify that all of the fan mounting hardware is tight.
- Inspect the F/A-R/A damper hinges and pins to ensure that all moving parts are securely mounted. Keep the blades clean as necessary.
- Verify that all damper linkages move freely; lubricate with white grease, if necessary.
- Check supply fan motor bearings; repair or replace the motor as necessary.
- Check the fan shaft bearings for wear. Replace the bearings as necessary.
- Verify that all wire terminal connections are tight.
- Remove any corrosion present on the exterior surfaces of the unit and repaint these areas.
- Generally inspect the unit for unusual conditions (e.g., loose access panels, leaking piping connections, etc.).
- Make sure that all retaining screws are reinstalled in the unit access panels once these checks are complete.
- With the unit running, check and record the: ambient temperature; compressor suction and discharge pressures (each circuit); superheat (each circuit); Record this data on an "operator's maintenance log" like the one shown in Table 9, p. 60. If the operating pressures indicate a refrigerant shortage, measure the system superheat.

Note: Do NOT release refrigerant to the atmosphere! If adding or removing refrigerant is required, the service technician must comply with all federal, state and local laws.

Heating Season

- Inspect the unit's air filters. If necessary, clean or replace them.
- Check supply fan motor bearings; repair or replace the motor as necessary.
- Inspect both the main unit control panel and heat section control box for loose electrical components and terminal connections, as well as damaged wire insulation. Make any necessary repairs.
- Verify that the electric heat system operates properly.

Condenser Coil Cleaning

Regular coil maintenance, including annual cleaning, enhances the unit's operating efficiency by minimizing: compressor head pressure and amperage draw; evaporator water carryover; fan brake horsepower, due to increase static pressure losses; airflow reduction.

At least once each year, or more often if the unit is located in a “dirty” environment, clean the condenser coils using the instructions outlined below. Be sure to follow these instructions as closely as possible to avoid damaging the coils.

Round Tube Plate Fin (RTPF) Coils

To clean refrigerant coils, use a soft brush and a sprayer (either a garden pump-up type or a high-pressure sprayer). A high-quality detergent is also required; suggested brands include “SPREX A.C.”, “OAKITE 161”, “OAKITE 166” and “COILOX”. If the detergent selected is strongly alkaline (pH value exceeds 8.5), add an inhibitor.

⚠ WARNING

Hazardous Chemicals!

Failure to follow all safety instructions below could result in death or serious injury. Coil cleaning agents can be either acidic or highly alkaline and can burn severely if contact with skin occurs. Handle chemical carefully and avoid contact with skin. ALWAYS wear Personal Protective Equipment (PPE) including goggles or face shield, chemical resistant gloves, boots, apron or suit as required. For personal safety refer to the cleaning agent manufacturer’s Materials Safety Data Sheet and follow all recommended safe handling practices.

⚠ AVERTISSEMENT

Produits chimiques dangereux!

Le non-respect de toutes les consignes de sécurité indiquées ci-après pourrait entraîner des blessures graves voire mortelles. Les agents de nettoyage pour serpentin peuvent être soit acides, soit fortement alcalins et peuvent entraîner des brûlures graves au contact de la peau. Manipulez les produits chimiques avec prudence et évitez tout contact avec la peau. Portez TOUJOURS un équipement de protection individuel (EPI), y compris des lunettes ou un masque facial, des gants résistant aux produits chimiques, des bottes, un tablier ou une combinaison conformément aux exigences. Pour la sécurité personnelle, voir les fiches de données de sécurité du fabricant pour l’agent de nettoyage et suivre toutes les pratiques de manipulation préconisées.

1. Remove enough panels from the unit to gain access to the coil.
2. Protect all electrical devices such as motors and controllers from any over spray.
3. Straighten any bent coil fins with a fin comb.

⚠ WARNING

Hazardous Pressures!

Failure to follow safety precautions below could result in coil bursting, which could result in death or serious injury. Coils contain refrigerant under pressure. When cleaning coils, maintain coil cleaning solution temperature under 150°F to avoid excessive pressure in the coil.

⚠ AVERTISSEMENT

Pressions dangereuses!

Tout manquement aux consignes de sécurité préconisées ci-dessous risquerait d’entraîner un éclatement du serpentin susceptible de provoquer des blessures graves voire mortelles. Les serpentins contiennent du fluide frigorigène sous pression. Lors du nettoyage des serpentins, maintenez la température de l’agent de nettoyage pour serpentin à moins de 65,5 °C (150 °F) pour éviter toute pression excessive dans le serpentin.

4. Mix the detergent with water according to the manufacturer’s instructions. If desired, heat the solution BUT DO NOT EXCEED 150°F maximum to improve its cleansing capability.
5. Pour the cleaning solution into the sprayer. If a high-pressure sprayer is used:
 - a. do not allow sprayer pressure to exceed 600 psi.
 - b. the minimum nozzle spray angle is 15°.
 - c. maintain a minimum clearance of 6 in. between the sprayer nozzle and the coil.
 - d. spray the solution perpendicular (at 90°) to the coil face.
6. Spray the leaving-airflow side of the coil first; then spray the opposite side of the coil. Allow the cleaning solution to stand on the coil for five minutes.
7. Rinse both sides of the coil with cool, clean water.
8. Inspect both sides of the coil; if it still appears to be dirty, repeat [Step 6](#) and [Step 7](#).
9. Reinstall all of the components and panels removed in [Step 1](#) and any protective covers installed in [Step 2](#).



General Data

Table 10. General data—Cooling 10–20 tons high efficiency

	10 Tons Downflow	12 Tons Downflow	15 Tons Downflow	17 Tons Downflow	20 Tons Downflow
	OADG010	OADG012	OADG015	OADG017	OADG020
Cooling Performance (6-row)					
Gross Cooling Capacity, Btu (kW)	134,530 (39.43)	153,380 (44.95)	192,718 (56.48)	215,551 (63.17)	248,068 (72.70)
Nominal cfm (m ³ /h)	1,500 (2,549)	1,800 (3,058)	2,250 (3,823)	2,550 (4,332)	3,000 (5,097)
Cooling Performance (4-row)					
Gross Cooling Capacity, Btu (kW)	135,303 (39.65)	151,147 (44.30)	186,972 (54.80)	213,659 (62.62)	242,918 (71.19)
Nominal cfm (m ³ /h)	4,000 (6,796)	4,800 (8,155)	6,000 (10,194)	6,800 (11,553)	8,000 (13,592)
Compressor					
Number	2	2	2	2	2
Type	Scroll	Scroll	Scroll	Scroll	Scroll
Outdoor Coil					
Type	High-Performance	High-Performance	High-Performance	High-Performance	High-Performance
Tube Size—OD, in. (mm)	3/8 (9.5)	3/8 (9.5)	3/8 (9.5)	3/8 (9.5)	3/8 (9.5)
Face Area, ft ² (m ²)	30 (2.79)	30 (2.79)	30 (2.79)	30 (2.79)	30 (2.79)
Rows	2	2	2	2	2
FPI	14	14	14	14	14
Indoor Coil					
Type	High-Performance	High-Performance	High-Performance	High-Performance	High-Performance
Tube Size (6-row)—OD, in. (mm)	3/8 (9.5)	3/8 (9.5)	3/8 (9.5)	1/2 (12.7)	1/2 (12.7)
Tube Size (4-row)—OD, in. (mm)	3/8 (9.5)	3/8 (9.5)	3/8 (9.5)	3/8 (9.5)	3/8 (9.5)
Face Area, ft ² (m ²)	10 (0.93)	10 (0.93)	10 (0.93)	17 (1.58)	17 (1.58)
Rows	6 or 4	6 or 4	6 or 4	6 or 4	6 or 4
FPI	14 or 15	14 or 15	14 or 15	14 or 15	14 or 15
Refrigerant Control	TXV	TXV	TXV	TXV	TXV
Drain Connection Number	1	1	1	1	1
Drain Connection Size, in. (mm)	1 (25.4)	1 (25.4)	1 (25.4)	1 (25.4)	1 (25.4)
Outdoor Fan					
Type	Propeller	Propeller	Propeller	Propeller	Propeller
Number Used	2	2	2	3	3
Diameter, in. (mm)	27 (685.8)	27 (685.8)	27 (685.8)	27 (685.8)	27 (685.8)
Drive Type	Direct	Direct	Direct	Direct	Direct
No. Speeds	1	1	1	1	1
Fan cfm (m ³ /h)	7,000 (11,893)	7,000 (11,893)	7,000 (11,893)	7,000 (11,893)	7,000 (11,893)
Number Motors	2	2	2	2	2
Motor HP (kW), per motor	1.0 (0.75)	1.0 (0.75)	1.0 (0.75)	1.0 (0.75)	1.0 (0.75)
Motor RPM	1,140	1,140	1,140	1,140	1,140
Indoor Fan					
Type	Airfoil	Airfoil	Airfoil	Airfoil	Airfoil
Number Used	1	1	1	1	1
Diameter	Varies	Varies	Varies	Varies	Varies
Drive Type	Direct Drive	Direct Drive	Direct Drive	Direct Drive	Direct Drive
Number Motors	1	1	1	1	1
Motor HP (kW)	1–7.5 (0.75–5.59)	1–7.5 (0.75–5.59)	1–7.5 (0.75–5.59)	1–7.5 (0.75–5.59)	1–7.5 (0.75–5.59)
Motor RPM	1750–3500	1750–3500	1750–3500	1750–3500	1750–3500
Motor Frame Size	Varies	Varies	Varies	Varies	Varies
Filters					
Type Furnished	Refer to "OAU Filter Guide" in "Appendix," p. 73	Refer to "OAU Filter Guide" in "Appendix," p. 73	Refer to "OAU Filter Guide" in "Appendix," p. 73	Refer to "OAU Filter Guide" in "Appendix," p. 73	Refer to "OAU Filter Guide" in "Appendix," p. 73
Number Size Recommended					



General Data

Table 11. General data—ASHP 10–20 tons high efficiency

	10 Tons Downflow	12 Tons Downflow	15 Tons Downflow	17 Tons Downflow	20 Tons Downflow
	OADG010	OADG012	OADG015	OADG017	OADG020
Performance					
Gross Cooling Capacity, Btu (kW)	131,284 (38.48)	149,705 (43.87)	187,181 (54.86)	217,530 (63.75)	250,834 (73.51)
Gross Heating Capacity, Btu (kW)	85,752 (25.13)	98,970 (29.01)	119,043 (34.89)	145,594 (42.67)	153,122 (44.88)
Nominal cfm (m ³ /h)	1,500 (2,549)	1,800 (3,058)	2,250 (3,823)	2,550 (4,332)	3,000 (5,097)
Compressor					
Number	2	2	2	2	2
Type	Scroll	Scroll	Scroll	Scroll	Scroll
Outdoor Coil					
Type	High-Performance	High-Performance	High-Performance	High-Performance	High-Performance
Tube Size—OD, in. (mm)	3/8 (9.5)	3/8 (9.5)	3/8 (9.5)	3/8 (9.5)	3/8 (9.5)
Face Area, ft ² (m ²)	30 (2.79)	30 (2.79)	30 (2.79)	29 (2.69)	29 (2.69)
Rows	2	2	2	3	3
FPI	14	14	14	12	12
Indoor Coil					
Type	High-Performance	High-Performance	High-Performance	High-Performance	High-Performance
Tube Size—OD, in. (mm)	3/8 (9.5)	3/8 (9.5)	3/8 (9.5)	3/8 (9.5)	3/8 (9.5)
Face Area, ft ² (m ²)	10 (0.93)	10 (0.93)	10 (0.93)	17 (1.58)	17 (1.58)
Rows	6	6	6	6	6
FPI	14	14	14	14	14
Refrigerant Control	TXV	TXV	TXV	TXV	TXV
Drain Connection Number	1	1	1	1	1
Drain Connection Size, in. (mm)	1 (25.4)	1 (25.4)	1 (25.4)	1 (25.4)	1 (25.4)
Outdoor Fan					
Type	Propeller	Propeller	Propeller	Propeller	Propeller
Number Used	2	2	2	3	3
Diameter, in. (mm)	27 (685.8)	27 (685.8)	27 (685.8)	27 (685.8)	27 (685.8)
Drive Type	Direct	Direct	Direct	Direct	Direct
No. Speeds	1	1	1	1	1
Fan cfm (m ³ /h)	7,000 (11,893)	7,000 (11,893)	7,000 (11,893)	7,000 (11,893)	7,000 (11,893)
Number Motors	2	2	2	3	3
Motor HP (kW), per motor	1.0 (0.75)	1.0 (0.75)	1.0 (0.75)	1.0 (0.75)	1.0 (0.75)
Motor RPM	1,140	1,140	1,140	1,140	1,140
Indoor Fan					
Type	Airfoil	Airfoil	Airfoil	Airfoil	Airfoil
Number Used	1	1	1	1	1
Diameter	Varies	Varies	Varies	Varies	Varies
Drive Type	Direct Drive	Direct Drive	Direct Drive	Direct Drive	Direct Drive
Number Motors	1	1	1	1	1
Motor HP (kW)	1–7.5 (0.75–5.59)	1–7.5 (0.75–5.59)	1–7.5 (0.75–5.59)	1–7.5 (0.75–5.59)	1–7.5 (0.75–5.59)
Motor RPM	1750–3500	1750–3500	1750–3500	1750–3500	1750–3500
Motor Frame Size	Varies	Varies	Varies	Varies	Varies
Filters					
Type Furnished	Refer to "OAU Filter Guide" in "Appendix," p. 73	Refer to "OAU Filter Guide" in "Appendix," p. 73	Refer to "OAU Filter Guide" in "Appendix," p. 73	Refer to "OAU Filter Guide" in "Appendix," p. 73	Refer to "OAU Filter Guide" in "Appendix," p. 73
Number Size Recommended					

Table 12. General data—Cooling 40–80 tons high efficiency

	40 Tons Downflow	45 Tons Downflow	50 Tons Downflow	55 Tons Downflow	60 Tons Downflow	70 Tons Downflow	80 Tons Downflow
	OANGO40	OANGO45	OANGO50	OANGO55	OANGO60	OANGO70	OANGO80
Cooling Performance (6-row)							
Gross Cooling Capacity, Btu (kW)	511,968 (150.04)	569,546 (166.92)	604,728 (177.23)	686,668 (201.24)	752,012 (220.39)	871,572 (255.43)	998,910 (292.75)
Nominal cfm (m ³ /h)	7,500 (12,743)	6,750 (11,468)	7,500 (12,743)	8,250 (14,017)	9,000 (15,291)	10,500 (17,840)	12,000 (20,388)
Cooling Performance (4-row)							
Gross Cooling Capacity, Btu (kW)	488,728 (143.23)	553,912 (162.34)	605,568 (177.47)	642,968 (188.44)	701,308 (205.53)	847,228 (248.30)	924,696 (271.00)
Nominal cfm (m ³ /h)	12,800 (21,747)	14,400 (24,466)	16,000 (27,184)	17,600 (29,903)	19,200 (32,621)	22,400 (38,058)	25,000 (42,475)
Compressor							
Number	4	4	4	4	4	4	4-6
Type	Scroll	Scroll	Scroll	Scroll	Scroll	Scroll	Scroll
Outdoor Coil							
Type	High-Performance	High-Performance	High-Performance	High-Performance	High-Performance	High-Performance	High-Performance
Tube Size—OD, in. (mm)	3/8 (9.5)	3/8 (9.5)	3/8 (9.5)	3/8 (9.5)	3/8 (9.5)	3/8 (9.5)	3/8 (9.5)
Face Area, ft ² (m ²)	30 (2.79)	30 (2.79)	30 (2.79)	48 (4.46)	48 (4.46)	48 (4.46)	48 (4.46)
Rows	3	3	3	3	3	3	3
FPI	14	14	14	14	14	14	14
Indoor Coil							
Type	High-Performance	High-Performance	High-Performance	High-Performance	High-Performance	High-Performance	High-Performance
Tube Size (6-row)—OD, in. (mm)	1/2 (12.7)	1/2 (12.7)	1/2 (12.7)	1/2 (12.7)	1/2 (12.7)	1/2 (12.7)	1/2 (12.7)
Tube Size (4-row)—OD, in. (mm)	3/8 (9.5)	3/8 (9.5)	3/8 (9.5)	3/8 (9.5)	3/8 (9.5)	3/8 (9.5)	3/8 (9.5)
Face Area (6-row), ft ² (m ²)	26 (2.42)	26 (2.42)	26 (2.42)	34 (3.16)	34 (3.16)	34 (3.16)	34 (3.16)
Face Area (4-row), ft ² (m ²)	34 (3.16)	34 (3.16)	34 (3.16)	2x21 (3.90)	2x21 (3.90)	2x21 (3.90)	2x21 (3.90)
Rows	6 or 4	6 or 4	6 or 4	6 or 4	6 or 4	6 or 4	6 or 4
FPI	14	14	14	14	14	14	14
Refrigerant Control	TXV	TXV	TXV	TXV	TXV	TXV	TXV
Drain Connection Number	1	1	1	1	1	1	1
Drain Connection Size, in. (mm)	1 (25.4)	1 (25.4)	1 (25.4)	1 (25.4)	1 (25.4)	1 (25.4)	1 (25.4)
Outdoor Fan							
Type	Propeller	Propeller	Propeller	Propeller	Propeller	Propeller	Propeller
Number Used	4	4	4	6	6	6	6
Diameter, in. (mm)	30 (762)	30 (762)	30 (762)	30 (762)	30 (762)	30 (762)	30 (762)
Drive Type	Direct	Direct	Direct	Direct	Direct	Direct	Direct
No. Speeds	1	1	1	1	1	1	1
Fan cfm (m ³ /h)	40,000 (67,960)	40,000 (67,960)	40,000 (67,960)	60,000 (101,941)	60,000 (101,941)	60,000 (101,941)	60,000 (101,941)
Number Motors	4	4	4	6	6	6	6
Motor HP (kW), per motor	1.5 (1.12)	1.5 (1.12)	1.5 (1.12)	1.5 (1.12)	1.5 (1.12)	1.5 (1.12)	1.5 (1.12)
Motor RPM	1,140	1,140	1,140	1,140	1,140	1,140	1,140
Indoor Fan							
Type	Backward Inclined	Backward Inclined	Backward Inclined	Backward Inclined	Backward Inclined	Backward Inclined	Backward Inclined
Number Used	1	1	1	1	1	1	1
Diameter, in. (mm)	Varies	Varies	Varies	Varies	Varies	Varies	Varies
Drive Type	Direct Drive	Direct Drive	Direct Drive	Direct Drive	Direct Drive	Direct Drive	Direct Drive
Number Motors	1	1	1	1	1	1	1
Motor HP (kW) (Standard/Oversized)	1.5–20 (1.12–14.91)	1.5–20 (1.12–14.91)	1.5–20 (1.12–14.91)	1.5–20 (1.12–14.91)	1.5–20 (1.12–14.91)	1.5–20 (1.12–14.91)	1.5–20 (1.12–14.91)



General Data

Table 12. General data—Cooling 40–80 tons high efficiency (continued)

	40 Tons Downflow	45 Tons Downflow	50 Tons Downflow	55 Tons Downflow	60 Tons Downflow	70 Tons Downflow	80 Tons Downflow
	OANG040	OANG045	OANG050	OANG055	OANG060	OANG070	OANG080
Motor RPM (Standard/ Oversized)	1750–3500	1750–3500	1750–3500	1750–3500	1750–3500	1750–3500	1750–3500
Motor Frame Size (Standard/Oversized)	Varies	Varies	Varies	Varies	Varies	Varies	Varies
Filters							
Type Furnished	Refer to "OAU Filter Guide" in		Refer to "OAU Filter Guide" in		Refer to "OAU Filter Guide" in		Refer to "OAU Filter Guide" in
Number Size Recommended	"Appendix," p. 73		"Appendix," p. 73		"Appendix," p. 73		"Appendix," p. 73

Table 13. General data—ASHP 40–80 tons high efficiency

	40 Tons Downflow	45 Tons Downflow	50 Tons Downflow	55 Tons Downflow	60 Tons Downflow	70 Tons Downflow	80 Tons Downflow
	OANG040	OANG045	OANG050	OANG055	OANG060	OANG070	OANG080
Cooling Performance							
Gross Cooling Capacity, Btu (kW)	495,304 (145.16)	558,120 (163.57)	577,584 (169.27)	670,550 (196.52)	719,942 (210.99)	842,536 (246.92)	928,964 (272.25)
Gross Heating Capacity, Btu (kW)	460,464 (134.95)	522,116 (153.02)	568,292 (166.55)	632,996 (185.51)	648,720 (190.12)	774,200 (226.90)	876,054 (256.75)
Nominal cfm (m ³ /h)	5,000–10,000 (8,495–16,990)	5,625–11,250 (9,557–19,114)	6,250–12,500 (10,619–21,238)	6,875–13,750 (11,681–23,361)	7,500–15,000 (12,743–25,485)	8,750–17,500 (14,866–29,733)	10,000–20,000 (16,990–33,980)
Compressor							
Number	4	4	4	4	4	4	5
Type	Scroll	Scroll	Scroll	Scroll	Scroll	Scroll	Scroll
Outdoor Coil							
Type	High- Performance	High- Performance	High- Performance	High- Performance	High- Performance	High- Performance	High- Performance
Tube Size—OD, in. (mm)	3/8 (9.5)	3/8 (9.5)	3/8 (9.5)	3/8 (9.5)	3/8 (9.5)	3/8 (9.5)	3/8 (9.5)
Face Area, ft ² (m ²)	45 (2.79)	45 (2.79)	45 (2.79)	45 (2.69)	45 (2.69)	45 (2.69)	45 (2.69)
Rows	2	2	2	2	2	3	3
FPI	14	14	14	14	14	14	14
Indoor Coil							
Type	High- Performance	High- Performance	High- Performance	High- Performance	High- Performance	High- Performance	High- Performance
Tube Size—OD, in. (mm)	1/2 (9.5)	1/2 (9.5)	1/2 (9.5)	1/2 (9.5)	1/2 (9.5)	1/2 (9.5)	1/2 (9.5)
Face Area, ft ² (m ²)	26 (0.93)	26 (0.93)	26 (0.93)	26 (1.58)	34 (1.58)	34 (1.58)	34 (1.58)
Rows	6	6	6	6	6	6	6
FPI	14	14	14	14	14	14	14
Refrigerant Control	TXV	TXV	TXV	TXV	TXV	TXV	TXV
Drain Connection Number	1	1	1	1	1	1	1
Drain Connection Size, in. (mm)	1 (25.4)	1 (25.4)	1 (25.4)	1 (25.4)	1 (25.4)	1 (25.4)	1 (25.4)
Outdoor Fan							
Type	Propeller	Propeller	Propeller	Propeller	Propeller	Propeller	Propeller
Number Used	4	4	4	6	6	6	6
Diameter, in. (mm)	30 (685.8)	30 (685.8)	30 (685.8)	30 (685.8)	30 (685.8)	30 (685.8)	30 (685.8)
Drive Type	Direct	Direct	Direct	Direct	Direct	Direct	Direct
No. Speeds	1	1	1	1	1	1	1
Fan cfm (m ³ /h)	40,000 (67,960)	40,000 (67,960)	40,000 (67,960)	60,000 (101,941)	60,000 (101,941)	60,000 (101,941)	60,000 (101,941)
Number Motors	6	6	6	6	6	6	6
Motor HP (kW), per motor	1.5 (1.12)	1.5 (1.12)	1.5 (1.12)	1.5 (1.12)	1.5 (1.12)	1.5 (1.12)	1.5 (1.12)
Motor RPM	1,140	1,140	1,140	1,140	1,140	1,140	1,140
Indoor Fan							
Type	Backward Inclined	Backward Inclined	Backward Inclined	Backward Inclined	Backward Inclined	Backward Inclined	Backward Inclined
Number Used	1	1	1	1	1	1	1

Table 13. General data—ASHP 40–80 tons high efficiency

	40 Tons Downflow	45 Tons Downflow	50 Tons Downflow	55 Tons Downflow	60 Tons Downflow	70 Tons Downflow	80 Tons Downflow
	OANG040	OANG045	OANG050	OANG055	OANG060	OANG070	OANG080
Diameter, in. (mm)	Varies	Varies	Varies	Varies	Varies	Varies	Varies
Drive Type	Direct Drive	Direct Drive	Direct Drive	Direct Drive	Direct Drive	Direct Drive	Direct Drive
Number Motors	1	1	1	1	1	1	1
Motor HP (kW) (Standard/ Oversized)	1.5–20 (1.12–14.91)	1.5–20 (1.12–14.91)	1.5–20 (1.12–14.91)	1.5–20 (1.12–14.91)	1.5–20 (1.12–14.91)	1.5–20 (1.12–14.91)	1.5–20 (1.12–14.91)
Motor RPM (Standard/ Oversized)	1750–3500	1750–3500	1750–3500	1750–3500	1750–3500	1750–3500	1750–3500
Motor Frame Size (Standard/Oversized)	Varies	Varies	Varies	Varies	Varies	Varies	Varies
Filters							
Type Furnished	Refer to "OAU Filter Guide" in	Refer to "OAU Filter Guide" in	Refer to "OAU Filter Guide" in	Refer to "OAU Filter Guide" in	Refer to "OAU Filter Guide" in	Refer to "OAU Filter Guide" in	Refer to "OAU Filter Guide" in
Number Size Recommended	"Appendix," p. 73	"Appendix," p. 73	"Appendix," p. 73	"Appendix," p. 73	"Appendix," p. 73	"Appendix," p. 73	"Appendix," p. 73

Superheat and Refrigeration Circuit Data

Figure 43. Refrigeration diagram: Tandem compressor without reheat

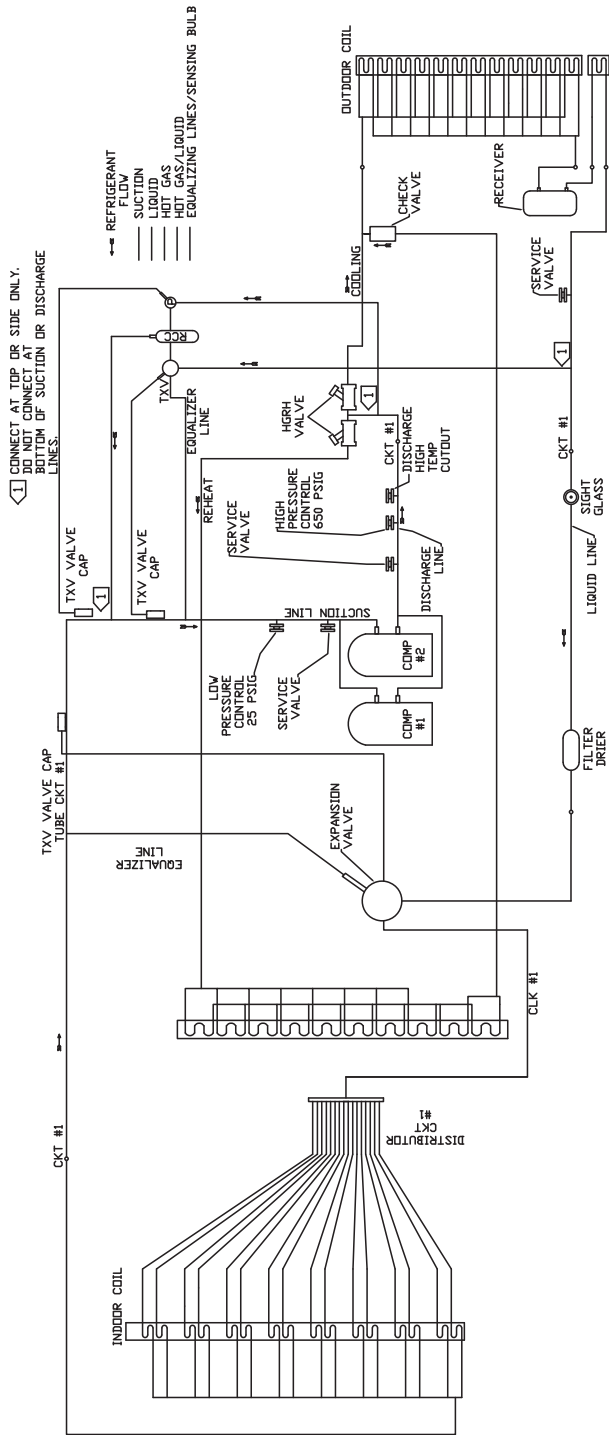

Figure 44. Refrigeration diagram: Tandem compressor with reheat

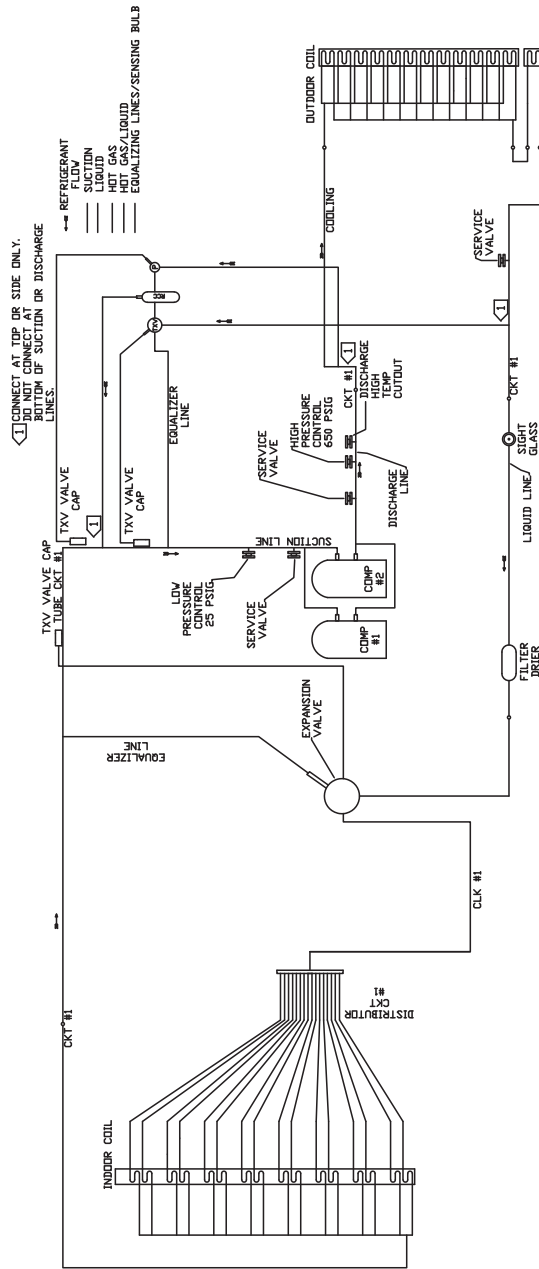

Figure 45. Refrigeration diagram: ASHP Tandem compressor without reheat

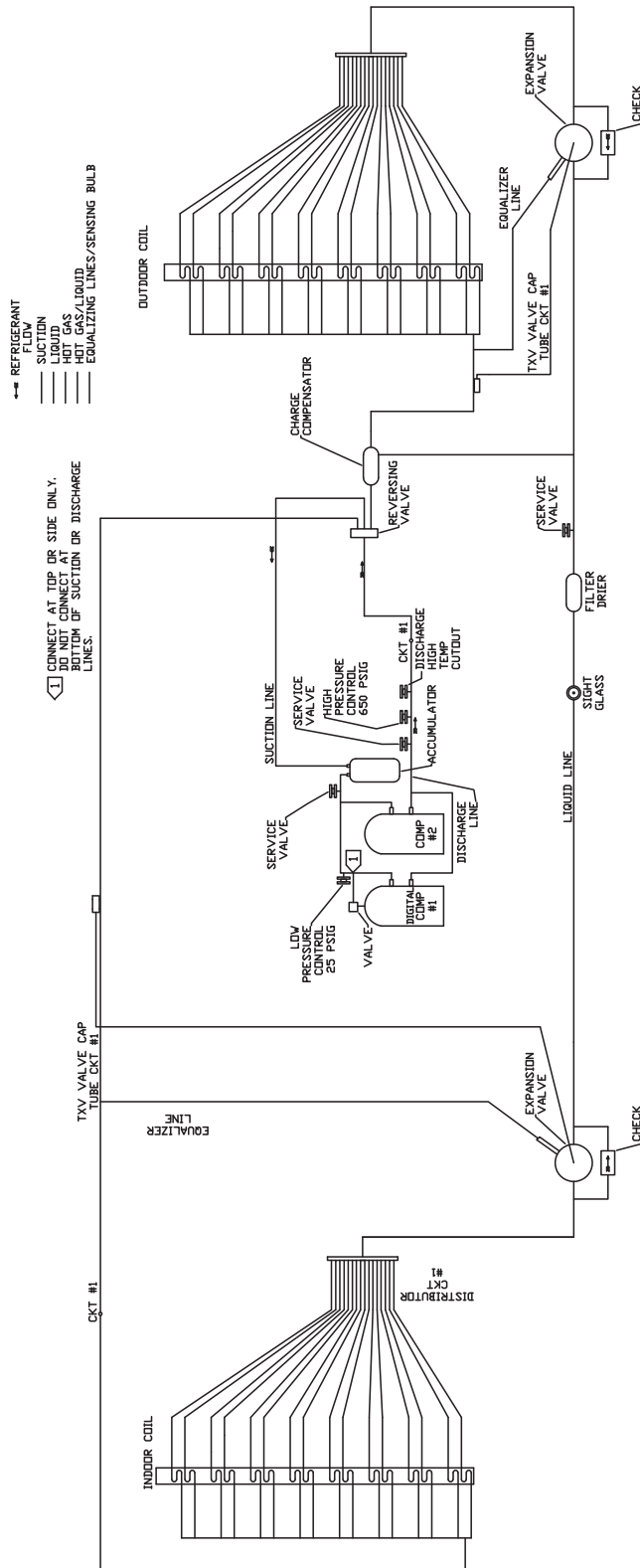
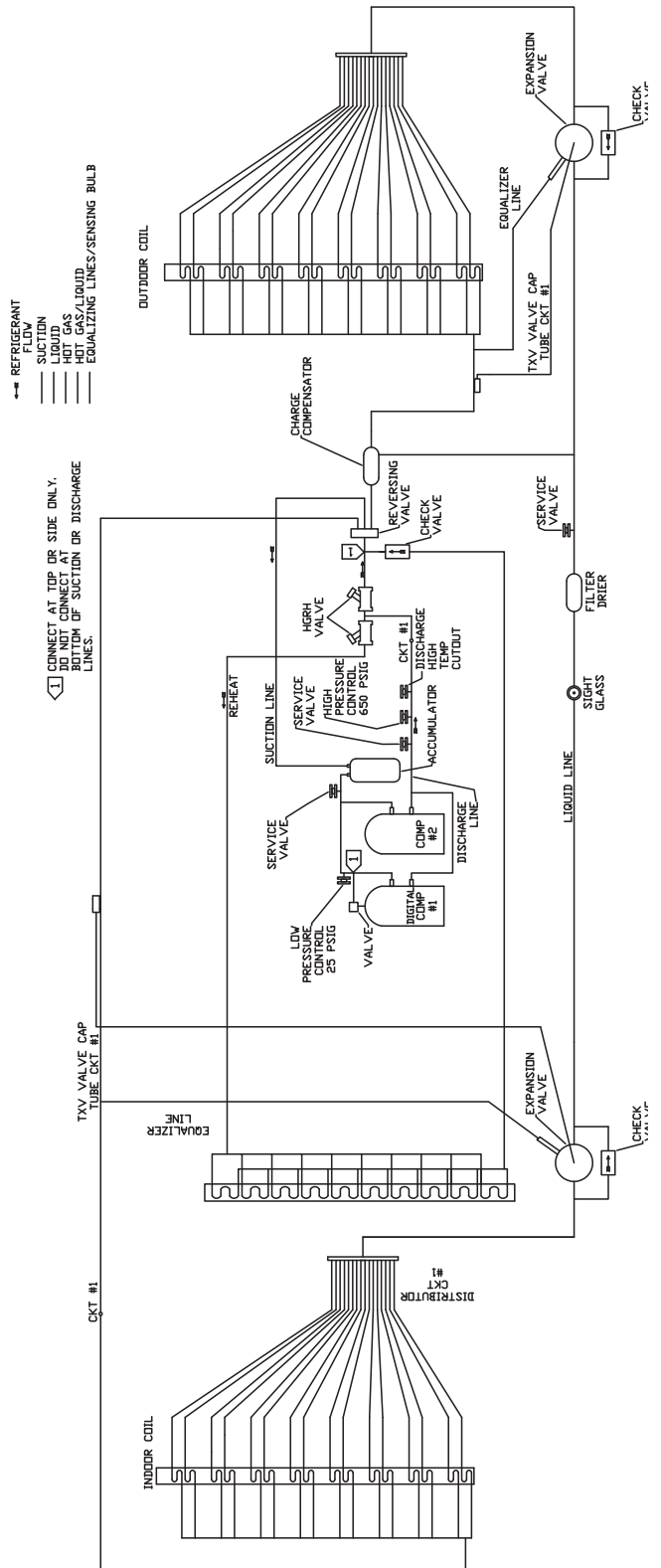

Figure 46. Refrigeration diagram: ASHP Tandem compressor with reheat





Alarms and Troubleshooting

Microprocessor Control

The Main Unit Display and RTRM have the ability to provide the service personnel with some unit diagnostics and system status information.

⚠ WARNING

Hazardous Service Procedures!

Failure to follow all precautions in this manual and on the tags, stickers, and labels could result in death or serious injury.

Technicians, in order to protect themselves from potential electrical, mechanical, and chemical hazards, **MUST** follow precautions in this manual and on the tags, stickers, and labels, as well as the following instructions: Unless specified otherwise, disconnect all electrical power including remote disconnect and discharge all energy storing devices such as capacitors before servicing. Follow proper lockout/tagout procedures to ensure the power can not be inadvertently energized. When necessary to work with live electrical components, have a qualified licensed electrician or other individual who has been trained in handling live electrical components perform these tasks.

⚠ AVERTISSEMENT

Procédures d'entretien dangereuses!

Le non-respect de toutes les précautions contenues dans ce manuel ainsi que sur les étiquettes et les autocollants peut entraîner des blessures graves voire mortelles.

Les techniciens, afin d'être protégés des éventuels risques électriques, mécaniques et chimiques, **DOIVENT** suivre les précautions contenues dans ce manuel, sur les étiquettes et les autocollants, ainsi que les instructions suivantes : Sauf indication contraire, coupez toute l'alimentation électrique y compris les disjoncteurs à distance et déchargez tous les dispositifs de stockage d'énergie comme les condensateurs avant l'entretien. Respectez les procédures de verrouillage et d'étiquetage appropriées pour éviter tout risque de remise sous tension accidentelle. S'il est nécessaire de travailler avec des composants électriques sous tension, demandez à un électricien qualifié et agréé ou à une autre personne ayant la formation nécessaire pour manipuler des composants électriques sous tension d'exécuter ces tâches.

1. Verify that the Liteport LED on the RTRM is burning continuously. If the LED is lit, go to [Step 3](#).
2. If the LED is not lit, verify that 24 Vac is presence between J1-1 and J1-2. If 24 Vac is present, proceed to [Step 3](#). If 24 Vac is not present, check the unit main power supply, check transformer (TNS1). Proceed to [Step 3](#) if necessary.

3. Utilizing "Method 1" in the RTRM "System Status Checkout Procedure", check the following:

- System status
- Cooling status

If a System failure is indicated, proceed to [Step 4](#). If no failures are indicated, proceed to [Step 5](#).

4. If a System failure is indicated, recheck [Step 1](#) and [Step 2](#). If the LED is not lit in [Step 1](#), and 24 Vac is present in [Step 2](#), the RTRM has failed. Replace the RTRM.
5. If no failures are indicated, use one of the override options to start the unit. Following the Override procedure will allow you to check all of the operating modes, and all of the external controls (relays, contactors, etc.) for each respective mode.
6. Refer to the sequence of operations for each mode, to assist in verifying proper operation. Make the necessary repairs and proceed to [Step 7](#).
7. If no abnormal operating conditions appear in the Override mode, release the override and turn the power "Off" at the main power disconnect switch.

System Alarms

The Main Unit Display has built in alarms to help the operator troubleshoot system failures. This section will describe these alarms and provide a guide to troubleshooting the all unit operating modes.

Comprehensive system alarms and diagnostics are accessed through the Alarms icon at the unit display discussed later in the section, or through Tracer TU programming on connected computer. Sensor failures may be viewed through the Alarms icon.

If an alarm is present, the main indicator light on the UC600 will blink red. If the optional unit display is installed, the Alarm icon on the display will register ALARM, illuminate red and flash.

Important: *The space temperature sensor (SPTC) and space relative humidity sensor (SPHC) will read failed if they are not connected; they will Alarm as "In Fault."*

Sensor Failure Alarm Display

Press the Alarm button on the Home display of the Unit Display to display system sensor status as described in [Table 14, p. 69](#).

Table 14. Diagnostic values

	Name	Manual or Auto Reset	Possible Causes
BV-01	Diagnostic: Supply Fan Failure	Manual Reset. Occurs when the supply fan is commanded on but the proving switch does not close after two minutes	<ul style="list-style-type: none"> • VFD not operating OA and/or RA dampers not operating properly • Indoor Fan Motor Failure • Indoor Fan Failure Switch IFFS (pressure) failure • IFFS tubing damaged or not properly connected
BV-02	Diagnostic: Discharge Air Humidity Source Failure	Auto Reset. Occurs when the discharge air humidity sensor falls outside of range	<ul style="list-style-type: none"> • BAS communication down • Failed sensor or improper sensor installation • Humidity Wiring Polarity sensitive
BV-03	Diagnostic: Outdoor Air Damper End Switch	Auto Reset. Occurs when there is a call for the two-position outdoor air damper but the end switch has no made for 180 seconds	<ul style="list-style-type: none"> • No voltage on actuator • Failed OAD power transformer • No continuity thru end switch (check at UC)
BV-06	Diagnostic: Discharge Air Temperature Source Failure	Auto Reset. Occurs when the discharge air temperature sensor falls outside of range	<ul style="list-style-type: none"> • BAS Communication Down • Failed sensor or improper sensor installation
BV-08	Diagnostic: Fire Shutdown	Auto Reset. Diagnostic from BAS communication. Unit resets once this returns to normal	<ul style="list-style-type: none"> • BAS only
BV-10	Diagnostic: Low Discharge Air Temp Lockout	Manual Reset. Occurs when the discharge air temperature is below 35°F for five minutes, or ten minutes during heat pump defrost mode	<ul style="list-style-type: none"> • Heat Overridden OFF • Compressor(s) Overridden ON • Setpoint Failures Incorrect • DAT sensor malfunction
BV-11	Diagnostic: Space Temperature Source Failure	Auto Reset. Occurs when the space temperature active falls outside of range	<ul style="list-style-type: none"> • BAS communication down • Failed sensor or improper sensor installation
BV-13	Diagnostic: Outdoor Air Temperature Source Failure	Auto Reset. Occurs when the outdoor air humidity active falls outside of range	<ul style="list-style-type: none"> • BAS Communication Down • Failed sensor or improper sensor installation
BV-14	Diagnostic: Outdoor Air Humidity Source Failure	Auto Reset. Occurs when the outdoor air temperature active falls outside of range	<ul style="list-style-type: none"> • BAS communication down • Failed sensor or improper sensor installation • Humidity Wiring Polarity sensitive
BV-15	Diagnostic: High Discharge Air Temp Lockout	Manual Reset. Occurs when the discharge air temperature is above 130°F for five minutes	<ul style="list-style-type: none"> • Heat Overridden ON • Low discharge air volume • Dirty Air filters • High gas heater manifold pressure • OA/RA damper position incorrect • High temp limit not properly installed or wired • DAT sensor malfunction



Alarms and Troubleshooting

Table 14. Diagnostic values (continued)

	Name	Manual or Auto Reset	Possible Causes
BV-19	Diagnostic: Space Humidity Source Failure	Auto Reset. Occurs when the space humidity active falls outside of range	<ul style="list-style-type: none"> • BAS communication down • Failed sensor or improper sensor installation • Humidity Wiring Polarity sensitive
BV-22	Diagnostic: Compressor Fail Unit Lockout	Manual Reset	Occurs when there is a compressor run failure and the discharge air temperature is 5°F from setpoint, or the dehumidification temperature is 5°F during dehumidification.
BV-24	Diagnostic: Exhaust Fan Failure	Auto Reset	Occurs when there is a call for exhaust fan but there is no status for three minutes
BV-28	Diagnostic: Condensate Overflow Unit Lockout	Auto Reset	<ul style="list-style-type: none"> • Occurs when the condensate switch is open and the discharge air temperature is 5°F from setpoint, or the dehumidification temperature is 5°F during dehumidification. • Shuts down entire unit until 5 minutes after the condensate switch closes.
BV-29	Diagnostic: Low Refrigerant Pressure Circuit 2	Auto Reset	Occurs when circuit 2 is running and the suction pressure transducer reads below 90PSI (cooling) or 55PSI (heat pump) for two minutes.
BV-30	Diagnostic: Duct Static Pressure Setpoint Range	Auto Reset	Occurs when the duct static setpoint is above 85% of the maximum limit for the hardwired input, below 5% of the full scale input, or less than the minimum.
BV-31	Diagnostic: Liquid Line Refrigerant Pressure Circuit 1 Source Failure	Auto Reset	Occurs when circuit 1 is running and the liquid line transducer is outside of the 150- 650PSI range for two minutes.
BV-32	Diagnostic: Liquid Line Refrigerant Pressure Circuit 2 Source Failure	Auto Reset	Occurs when circuit 2 is running and the liquid line transducer is outside of the 150- 650PSI range for two minutes.
BV-33	Diagnostic: Low Outdoor Coil Water Flow	Auto Reset	<ul style="list-style-type: none"> • Occurs when the supply fan is running and the outdoor coil water flow switch is open.
BV-34	Diagnostic: Dehumidification Temperature Sensor Source Failure	Auto Reset	<ul style="list-style-type: none"> • Occurs when the indoor coil leaving or discharge air temperature/humidity sensor falls outside of range.
BV-35	Diagnostic: Compressor 1 Run Failure	Manual or Auto Reset	<ul style="list-style-type: none"> • Occurs when there is a call for a compressor without a run status for five minutes. Auto • resets after three hours.
BV-36	Diagnostic: Duct Static Pressure Source Failure	Auto Reset	<ul style="list-style-type: none"> • Occurs when the supply duct static pressure transducer reading falls outside of range.
BV-37	Diagnostic: Outdoor Coil Water Temperature Low	Auto Reset	Occurs when the supply fan is running and the outdoor coil water low temperature switch is open.
BV-38	Diagnostic: Low Refrigerant Pressure Circuit 1	Auto Reset	Occurs when circuit 1 is running and the suction pressure transducer reads below 90PSI (cooling) or 55PSI (heat pump) for two minutes.

Table 14. Diagnostic values (continued)

	Name	Manual or Auto Reset	Possible Causes
BV-42	Diagnostic: Heat Failure	Auto Reset (4 hours). Occurs when there is a call for heat but the heat status relay is not energized. The heat is cycled three times and then locked out for four hours before retrying	<ul style="list-style-type: none"> • Trips after heat command ON and no GV status offer 1 minute • No gas, low gas pressure or high gas pressure to unit • Unit Manual shutoffs closed • Heater inducer failure • Heat relay failure • Loose or incorrect wiring
BV-46	Diagnostic: Not Economizing When It Should Be Economizing	Auto Reset	Occurs when the unit is in economizer mode and the outdoor air damper feedback status is greater than 20% lower than the output.
BV-47	Diagnostic: Return Duct/Space Pressure Setpoint Range	Auto Reset	Occurs when the duct static setpoint is above 85% of the maximum limit for the hardwired input, below 5% of the full scale input, or less than the minimum.
BV-48	Diagnostic: Damper Not Modulating	Auto Reset	Occurs when the outdoor air damper position feedback is more more than 20% off than the output.
BV-50	Diagnostic: Space CO2 Source Failure	Auto Reset	Occurs when the space CO2 reading falls outside of range.
BV-52	Diagnostic: Compressor 2 Run Failure	Manual or Auto Reset	Occurs when there is a call for a compressor without a run status for five minutes. Auto resets after three hours.
BV-53	Diagnostic: Compressor 3 Run Failure	Manual or Auto Reset	Occurs when there is a call for a compressor without a run status for five minutes. Auto resets after three hours.
BV-54	Diagnostic: Compressor 4 Run Failure	Manual or Auto Reset	Occurs when there is a call for a compressor without a run status for five minutes. Auto resets after three hours.
BV-55	Diagnostic: Return Duct/Space Pressure Source Failure	Auto Reset	Occurs when the return duct/space pressure transducers falls outside of range.
BV-56	Diagnostic: Outdoor Air Flow Sensor Source Failure	Auto Reset	Occurs when the outdoor air damper is above 15% and the outdoor air flow measurement shows less than 50cfm.
BV-58	Diagnostic: Compressor 5 Run Failure	Manual or Auto Reset	Occurs when there is a call for a compressor without a run status for five minutes. Auto resets after three hours.
BV-59	Diagnostic: Compressor 6 Run Failure	Manual or Auto Reset	Occurs when there is a call for a compressor without a run status for five minutes. Auto resets after three hours.
BV-60	Diagnostic: Energy Recovery Wheel Rotation Failure	Auto Reset	Occurs when there is a call for the ERV but rotation was not detected for five minutes.

RTRM Failure Modes
⚠ WARNING
Live Electrical Components!

Failure to follow all electrical safety precautions when exposed to live electrical components could result in death or serious injury. When necessary to work with live electrical components, have a qualified licensed electrician or other individual who has been properly trained in handling live electrical components perform these tasks.

⚠ AVERTISSEMENT
Composants électriques sous tension!

Le non-respect de toutes les consignes de sécurité lors de la manipulation de composants électriques sous tension peut entraîner des blessures graves, voire mortelles. S'il est nécessaire de travailler avec des composants électriques sous tension, demandez à un électricien qualifié et agréé ou à une autre personne ayant la formation nécessaire pour manipuler des composants électriques sous tension d'exécuter ces tâches.

Following is the listing of RTRM failure indication causes.

System Failure

Check the voltage between RTRM terminals 6 and 9 on J6, it should read approximately 32 Vdc. If no voltage is present, a System failure has occurred. Refer to [Step 4](#) in "Microprocessor Control," p. 68 for the recommended troubleshooting procedure.

Cooling Failure

- CLP1 has opened during the 3 minute minimum "on time" during four consecutive compressor starts, check CLP1 or CLP2 by testing voltage between the J1-8 and J3-2 terminals on the RTRM and ground. If 24 Vac is present, the CLPs have not tripped. If no voltage is present, CLPs have tripped.

System Failure

Measure the voltage between terminals J6-9 and J6-6.

Normal Operation = approximately 32 Vdc

System Failure = less than 1 Vdc, approximately 0.75 Vdc

Cool Failure

Measure the voltage between terminals J6-8 and J6-6.

Cool Operating = approximately 32 Vdc

Cool Off = less than 1 Vdc, approximately 0.75 Vdc

Cooling Failure = voltage alternates between 32 Vdc and 0.75 Vdc

Condenser Fan VFD Troubleshooting
Table 15. Status indications

Upper Row String	Description	Drive Output Stage
Inhibit	The drive is inhibited and cannot be run. The SAFE TORQUE OFF signal is not applied to SAFE TORQUE OFF terminals or Pr06.015 is set to 0.	Disabled
Ready	The drive is ready to run. The drive enable is active, but the drive inverter is not active because the final drive run is not active.	Disabled
Stop	The drive is stopped/holding zero speed.	Enabled
Run	The drive is active and running.	Enabled
Supply Loss	Supply loss condition has been detected.	Enabled
Deceleration	The motor is being decelerated to zero speed/frequency because the final drive run has been deactivated.	Enabled
Trip	The drive has tripped and is no longer controlling the motor. The trip code appears in the lower display.	Disabled
Active	The regen unit is enabled and synchronized to the supply.	Enabled
Under Voltage	The drive is in the under voltage state either in low voltage or high voltage mode.	Disabled
Heat	The motor pre-heat functions inactive.	Enabled



Appendix

OAU Filter Guide

Table 16. OAD units

Evaporator				
Thickness, in. (cm)	MERV	Qty	Height, in. (cm)	Width, in. (cm)
2 (5.1)	8, 13	6	24 (63.5)	18 (45.7)
4 (10.2)	14	6	24 (63.5)	18 (45.7)
ERV Module				
Return Air				
Thickness, in. (cm)	MERV	Qty	Height, in. (cm)	Width, in. (cm)
2 (5.1)	8	6	20 (50.8)	20 (50.8)
Outside Air^(a)				
Thickness, in. (cm)	MERV	Qty	Height, in. (cm)	Width, in. (cm)
2 (5.1)	8	6	20 (50.8)	20 (50.8)
Inlet Hood				
Thickness, in. (cm)	Material	Qty	Height, in. (cm)	Width, in. (cm)
2 (5.1)	Aluminum Mesh	6	20 (50.8)	20 (50.8)

(a) No filters will be provided on the outside air path of the ERV section if electric preheat is provided.

Table 17. OAN units

Evaporator (40 to 50 ton - 4 and 6 row coils; 55 to 100 ton - 6 row coils)				
Thickness, in. (cm)	MERV	Qty	Height, in. (cm)	Width, in. (cm)
2 (5.1)	8, 13	15	20 (50.8)	18 (45.7)
4 (10.2)	14	15	20 (50.8)	18 (45.7)
Evaporator (55 to 100 ton - 4 row coils)				
Thickness, in. (cm)	MERV	Qty	Height, in. (cm)	Width, in. (cm)
2 (5.1)	8, 13	12	20 (50.8)	25 (63.5)
4 (10.2)	14	12	20 (50.8)	25 (63.5)
ERV Module				
Return Air				
Thickness, in. (cm)	MERV	Qty	Height, in. (cm)	Width, in. (cm)
2 (5.1)	8	15	24 (61.0)	18 (45.7)
Outside Air^(a)				
Thickness, in. (cm)	MERV	Qty	Height, in. (cm)	Width, in. (cm)
2 (5.1)	8	15	24 (61.0)	18 (45.7)
Inlet Hood				
Thickness, in. (cm)	Material	Qty	Height, in. (cm)	Width, in. (cm)
2 (5.1)	Aluminum Mesh	12	24 (61.0)	24 (61.0)

(a) No filters will be provided on the outside air path of the ERV section if electric preheat is provided.

Field Installation of Factory-Provided Sensors

Figure 47. VELSEN-0021 installation instructions

TYPICAL UNIT SHOWN

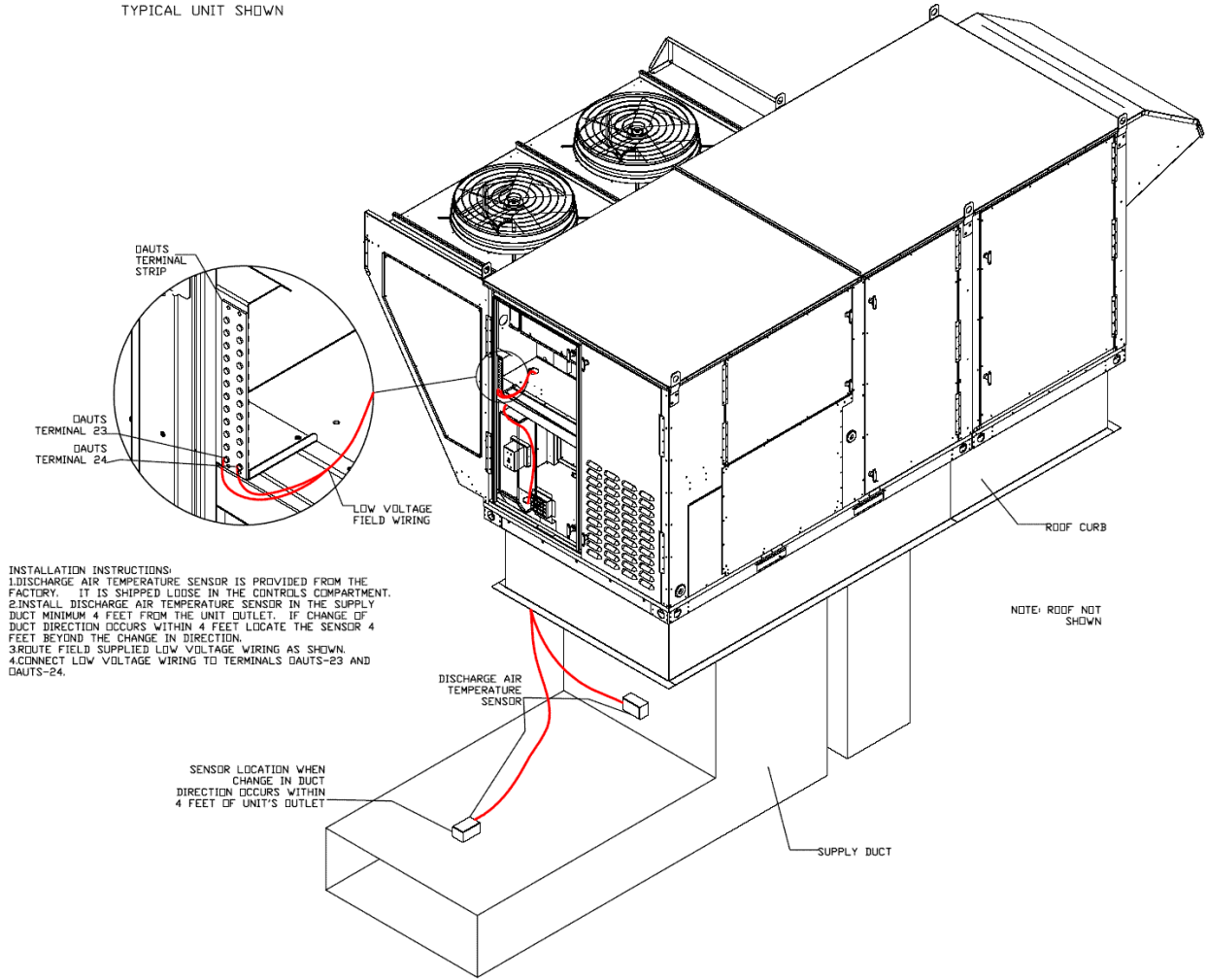
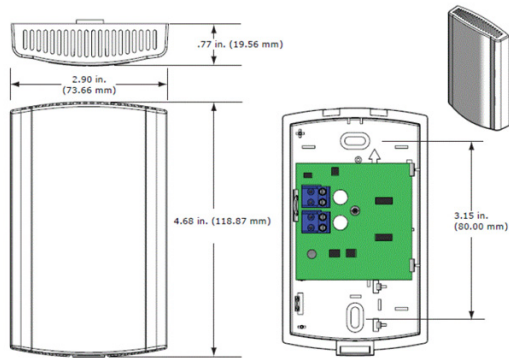

Figure 48. BAYSENS036A installation instructions

Sensor Specifications

Accuracy:	±3% RH over 20–95% RH at 77°F (25°C). Includes hysteresis, linearity, and repeatability.
Operating temperature range:	From -20°F to 140°F (-29°C to 60°C)
Supply voltage:	18-36 Vdc
Drift rate:	Less than 1% per year
Operating measurement range:	0-99% RH, noncondensing
Sensing element:	Polymer capacitive
Output characteristics:	4-20 mA for 0-100% RH (X13790486010 is 20- mA for 0-100% RH)
Repeatability:	0.5% RH
Hysteresis:	Less than 1% RH
Sensitivity:	0.1% RH
Storage temperature:	From -85°F to 158°F (-65°C to 70°C)
Thermistor resistance:	10 kΩ at 77°F
Temperature accuracy:	±0.36°F (±0.2°C)

Sensor Dimensions and Locating Best Practices



Mounting

Proper location of the **room humidity sensor** is important to ensure accurate measurement. Place the sensor in an area of the room with good air circulation.

Places to avoid when locating the sensor:

- Locations subject to draft from windows, doors, or diffusers
- Surfaces with an uncooled or unheated area behind them, such as an outside wall or the wall of an unoccupied store room
- Near heat sources, such as radiant heat from the sun, heat from appliances, or heat from concealed pipes or chimneys
- Dead spots behind doors, draperies, or in corners
- Walls having excessive vibration
- Corrosive environments such as near swimming pools or in hospital rooms

- To mount the **room humidity sensor**, first choose a flat interior surface that is approximately 54 inches (1.4 m) from the floor and then:
1. Remove sensor cover by pressing on the thumb tab at the bottom of the enclosure. Tilt the cover forward and raise it over the top of the back plate.
 2. Feed the wires through the base.
 3. Attach sensor to drywall or plaster (hardware not included with the sensor).

Note: For a 2 x 4 junction box, mount the sensor using two #6-32 screws.

4. Connect the controller wires to the terminals on the sensor (refer to the next section about wiring).
5. Replace cover by engaging tab hinges on top of the unit and then push to snap in place.

Figure 49. Supply duct static pressure transducer (SDPC)

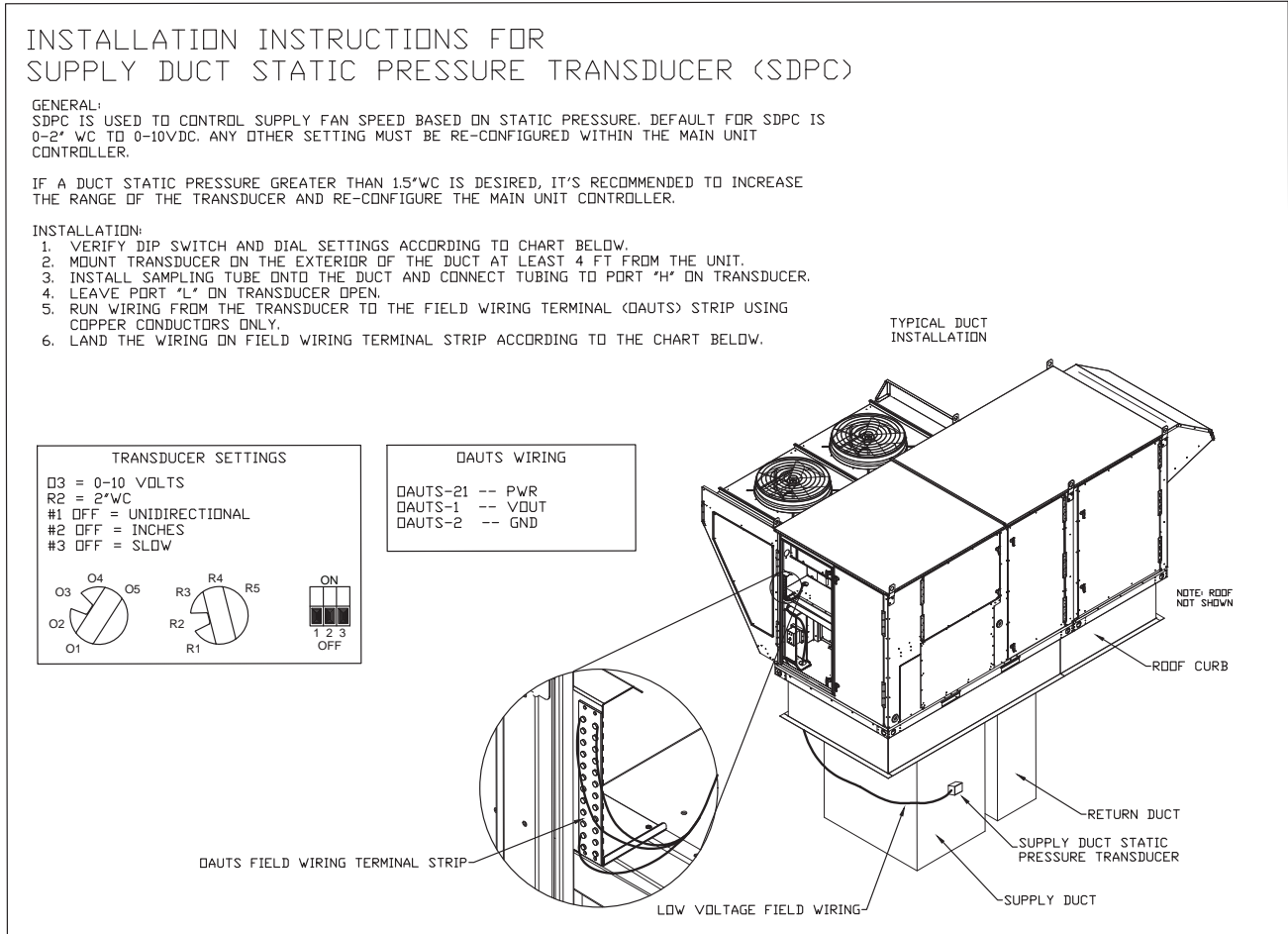

Figure 50. Return duct/space pressure transducer (RDSPC)

**INSTALLATION INSTRUCTIONS FOR
RETURN DUCT/SPACE PRESSURE TRANSDUCER (RDSPC)**

GENERAL:
RDSPC IS USED TO CONTROL EXHAUST FAN SPEED BASED ON STATIC PRESSURE. DEFAULT FOR RDSPC IS 0-2" WC TO 0-10VDC. ANY OTHER SETTING MUST BE CHANGED WITHIN THE MAIN UNIT CONTROLLER.

FACTORY SUPPLIED TRANSDUCER IS NOT RECOMMENDED FOR CONTROLLING TO SPACE PRESSURE. IF SPACE PRESSURE CONTROL IS DESIRED, USE A TRANSDUCER WITH A RANGE OF -0.5 TO 0.5"WC FOR PROPER OPERATION AND RE-CONFIGURE THE MAIN UNIT CONTROLLER.

INSTALLATION:

1. VERIFY DIP SWITCH AND DIAL SETTINGS ACCORDING TO CHART BELOW.
2. MOUNT TRANSDUCER ON THE EXTERIOR OF THE DUCT AT LEAST 4 FT FROM THE UNIT.
3. INSTALL SAMPLING TUBE ONTO THE DUCT AND CONNECT TUBING TO PORT "L" ON TRANSDUCER.
4. LEAVE PORT "H" ON TRANSDUCER OPEN.
5. RUN WIRING FROM THE TRANSDUCER TO THE FIELD WIRING TERMINAL (DAUTS) STRIP USING COPPER CONDUCTORS ONLY.
6. LAND THE WIRING ON FIELD WIRING TERMINAL STRIP ACCORDING TO THE CHART BELOW.

TRANSDUCER SETTINGS

Q3 = 0-10 VOLTS
R2 = 2"WC
#1 OFF = UNIDIRECTIONAL
#2 OFF = INCHES
#3 OFF = SLOW

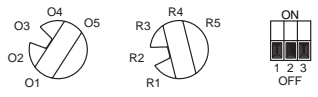

DAUTS WIRING

DAUTS-21 -- PWR
DAUTS-22 -- VDUT
DAUTS-24 -- GND

TYPICAL DUCT
INSTALLATION

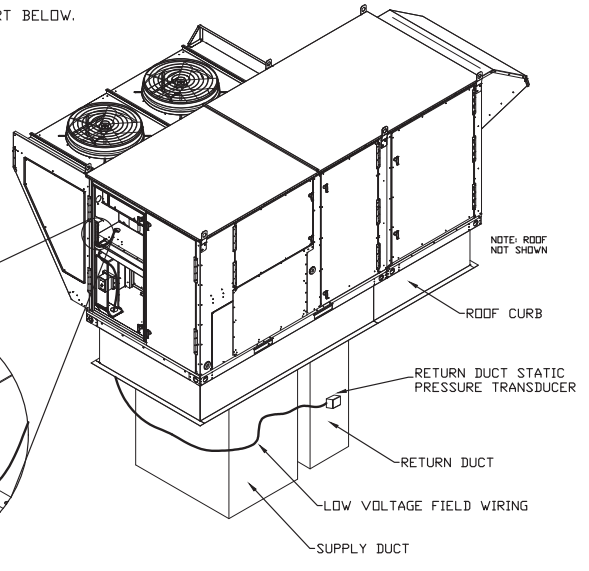

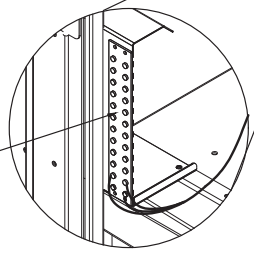

DAUTS FIELD WIRING TERMINAL STRIP



Attention Startup or Service Technician

Horizon UC600 v11.0 Released

The programming has gone through an overhaul. Take a moment to read through the Sequence of Operation included in this packet to familiarize yourself with the new operation.

Note: *Program v11.0 is not backwards compatible with previous Horizon units. The point configuration has changed, and suction pressure transducers are required for proper operation. In the future, a package will be made available that's backwards compatible with units manufactured after Jan 1st, 2019.*

Documents Included in This Packet:

1. Sequence of Operation – Full Horizon sequence, not unit-specific.
2. New Startup Form
3. Unit-Specific Points List – Points not relevant to the unit have been removed from this document.

Unchanged from Previous Versions:

- All programming and points built in. UC600 determines sequence based on configurable points and what points are Out of Service (mostly Analog and Binary Inputs/Outputs).
- Verifying setpoints with the customer is recommended.

Summary of Improvements

Suction Pressure Monitoring

All units with compressors will come standard with a refrigeration suction pressure transducer on circuit one. Units with digital scroll on the second circuit will also have a transducer on the second circuit.

Suction pressure will be used during cooling and dehumidification to limit capacity to prevent frost on the evaporator. An informational diagnostic will be displayed if this occurs repeatedly.

Compressor Run Status and Diagnostics

Each compressor will now have a run status by using the compressor auxiliary contactor. A diagnostic will be displayed if there is a call for a compressor with no status.

Updated Point Names to Match Tracer SC

Where possible, all points will be updated so that they match with standard Tracer SC key names.

Evaporator Leaving Temperature Setpoint Reset

Single Zone VAV and Space Control units: During

dehumidification mode the unit will reset the evaporator setpoint by comparing the space conditions to the setpoints. Previously a fixed setpoint for the evaporator temperature was used during dehumidification.

Minimum Supply Air Flow Setpoints

VAV units will now have separate minimum air flows during heating or cooling operation. Previously, the setting used was the highest value for all modes of operation. If these values are lower than a minimum outdoor air flow setpoint, then the outdoor air setpoint is used.

Single Zone VAV Mod. Air Flow - Heating Mode

Single Zone VAV will now modulate supply air flow to maintain space temperature. Previously it was constant volume during heating mode.

Gas Heater Staging Off at Minimum Capacity

The first stage of gas heat will now stage off if the heat capacity is at minimum. Previously, the first stage of heat was locked on whenever the unit was in heating mode. 2-minute delays have been added to prevent short cycling.

Reduced Hot Gas Reheat Purge Mode

Previously, if the hot gas reheat was above 0% for 30 minutes, it entered a 3-minute purge cycle at 100% signal. Now, if the hot gas reheat is between 10% and 50% for 30 minutes, it will enter a 2-minute purge cycle. First half is at 80% signal, second half is at 10% signal.

Unit Shutdown Due to Condensate Overflow

If the condensate overflow switch signals an alarm, and the unit is far from meeting setpoint, the unit is shut down and a diagnostic is displayed. Condensate switch required.

Liquid Line Pressure Setpoint Reset

For maximum efficiency, the liquid line pressure setpoint defaults to 325PSI during regular cooling mode. During dehumidification it resets to 450PSI for maximum reheat capacity in all conditions. Head Pressure Control is required.

Modulating ERV Exhaust and Outdoor Air Bypass

All units with an Energy Recovery Wheel (ERV) will now have modulating bypass for both the outdoor (OA) and exhaust air (EA). Modulating OA bypass is used to prevent frosting of the ERV. Modulating EA bypass operates with the primary heater and is used to prevent overheating on mild days.

Space Control or Single Zone VAV and OA Setpoints

Space Control or Single Zone VAV will no longer use the outdoor air setpoints if the unit has an ERV, or if the unit is not 100% outdoor air. Space conditions are used for determining all modes of operation.

Discharge Air Temp. Reset for Single Zone VAV

Single Zone VAV controls cooling and heating to constant discharge air temperature, with the supply fan controlling to space conditions. To reduce energy usage during extremely low load days, the unit will reset the *Discharge Air Temperature Setpoint Active* whenever the supply air flow is within 10% of the minimum setpoint.

Supply Fan Tracking for Exhaust Fan (Field Enabled)

VAV units can now have the exhaust fan track with the supply air as it changes speed. The exhaust fan speed will be 90% (adj.) of the supply fan speed.

Hot Water Reheat

Units with hot water installed will default from the factory to use the hot water as reheat for chilled water, or supplement hot gas reheat when it's at 100% capacity.

Expanded Fallback Control

Where possible, the unit will fall back to other methods of control when it detects a failed sensor. A diagnostic is displayed for the sensor when another sensor is being used.

- Evaporator temperature sensor fail -> use suction pressure.
- Supply duct static pressure sensor fail -> use constant volume at minimum air flow.
- Space temperature sensor fail -> use constant discharge air temperature.
- Space relative humidity sensor fail -> use constant evaporator leaving temperature.

Expanded Diagnostics

- Refrigerant Pressure Diagnostics (Liquid or Suction) if they fall outside of acceptable ranges during operation.
- Water Flow or Temperature Diagnostics for the outdoor water coil if there is no flow or low temperature with a demand for heating or cooling (WSHP only).
- Compressor Run Fail Diagnostics if there is a command, but not a run status.
- Unit Shutdown Due to Compressor Diagnostics, Heat Fail, or Condensate Overflow will shut the unit down if cooling or heating is not working properly and the unit is supplying well outside of acceptable ranges.
- Return Duct/Space Pressure Source Fail when there is no input from the transducer.
- Duct Static Pressure Setpoint Range and Return Duct/Space Pressure Setpoint Range when the setpoints aren't within an acceptable range in comparison to the hardwired input. Alarm is shown when setpoint is:
 - Above 85% of max range,
 - Below min range,
 - Below 5% of the difference between the min and max.
- Outdoor Air Flow Source Fail when the outdoor air damper is open, supply fan is on, but there's no air flow reading.



Sequence of Operation

General

Text shown in *italics* are point names in the programming.

Typically, points ending with "Local" are hardwired inputs, points ending with "Active" are determined by the program and can't be adjusted by the operator or BAS.

Discharge Air Temperature Setpoint Maximum is adjustable but cannot exceed 120°F for gas, heat pump, or hot water heating, and 90°F for electric heating.

Program Control Type can be determined using Multi-State Value 13.

Note: *There is a 3-minute delay during compressor or gas heater staging to allow the system to stabilize before adjusting the cooling or heating capacity.*

Program-Controlled Setpoints

Space Control and Single Zone VAV Control

Discharge Air Temperature Setpoint Active is reset by comparing the *Space Temperature Active to Occupied Cooling Setpoint* during cooling and *Occupied Heating Setpoint* during heating. If a single setpoint is preferred, use *Space Temperature Setpoint BAS* by putting it In Service using Tracer TU or BAS.

Dehumidification Temperature Setpoint Active is reset by comparing the *Space Dewpoint* to the *Space Dewpoint Calculated Enable Setpoint* minus 2°F.

If *Space Temperature Setpoint BAS* or *Space Temperature Setpoint Local* (Thumbwheel) is In Service, *Occupied Offset* is adjustable (2°F default). Otherwise, is determined using *Occupied Cooling Setpoint* and *Occupied Heating Setpoint*.

If *Occupied Cooling Setpoint* is below *Occupied Heating Setpoint*, *Occupied Offset* is 1°F. If *Occupied Cooling Setpoint* is above *Occupied Heating Setpoint*, *Occupied Offset* is the difference between the two setpoints.

Space Dewpoint Calculated Enable Setpoint is calculated using *Space Humidity Setpoint* and *Space Temperature Setpoint Active*.

Discharge Air Control and Multi-Zone VAV Control

Discharge Air Temperature Setpoint Active is controlled by *Discharge Air Cooling Setpoint BAS* during cooling operation, and *Discharge Air Heating Setpoint BAS* during heating. If *Discharge Air Temperature Setpoint BAS* is In Service, the program will use this over the discharge cooling and heating setpoints.

Dehumidification Temperature Setpoint Active is controlled by *Dehumidification Temperature Setpoint*.

Occupied Control

Starting Sequence

Occupied operation begins when the unit is placed in Occupied via BAS or when OAUTS-7 & 8 is closed on the field wiring terminal strip. The unit must not be in *Emergency Stop* to begin starting sequence. OAUTS-9 & 10 on the field wiring terminal strip are used as an external *Emergency Stop* for the unit. Cycling power to unit to may not resolve alarm condition.

Refer to Multi-State Value *Occupancy Status* to determine the active status of the unit.

Two-Position Outdoor Air Damper will begin by energizing relay OADR, opening the outdoor air damper. The supply fan sequence begins once the end switch is closed.

Two-Position Outdoor and Return Air Dampers will begin by energizing relay OADR, opening the outdoor air damper and closing the return air damper. The supply fan sequence starts immediately after the unit becomes occupied.

Modulating Outdoor and Return Air Dampers will begin by adjusting the *Outdoor Air Damper Position Command* to meet the *Outdoor Air Damper Minimum Position Setpoint*. The supply fan sequence starts immediately after the unit becomes occupied.

Supply Fan Sequence

Supply Fan Starting Sequence begins by energizing relay G and setting the *Supply Fan Speed Command* to 50%. The supply fan status switch (IFFS) closes, energizing relay IFFR. If after two minutes there is no proven signal, *Diagnostic: Supply Fan Failure* will be displayed, and the unit will shut down requiring a manual reset.

Constant Volume with VFD

After completing the starting sequence, the supply fan will run to the *Supply Fan Speed Setpoint*, field adjustable from 50-100% (defaulted 100%).

Constant Volume with ECM

After completing the starting sequence, the unit calculates the *Supply Fan Air Flow Active* and adjusts *Supply Fan Speed Command* to maintain the *Supply Fan Air Flow Setpoint* (adjustable, factory set according to submittal).

Multi Zone VAV Control

After completing the starting sequence, the unit adjusts fan speed to maintain *Duct Static Pressure Active* to *Duct Static Pressure Setpoint BAS*. Supply fan speed is limited between *Supply Air Flow Minimum Setpoint Active* and *Supply Air Flow Maximum Setpoint* (both factory set).

Single Zone VAV Control

After completing the starting sequence, the unit adjusts supply fan speed to maintain *Space Temperature Active* to *Space Temperature Setpoint Active*. When the unit is in *Dehumidification Mode*, the unit adjusts the supply fan speed to maintain the *Space Dewpoint* to the *Space Dewpoint Calculated Enable Setpoint*.

Supply fan speed is limited between *Supply Air Flow Minimum Setpoint Active* and *Supply Air Flow Maximum Setpoint* (both factory set).

Field Enabled Space Pressure Control

Units ordered as constant volume can be field enabled to control the supply fan speed to a pressure input. *Duct Static Pressure Local* must be put In Service, configured, and referenced to an open input using Tracer TU. The program will automatically adjust supply fan speed to maintain *Duct Static Pressure Setpoint BAS*.

Economizer Mode

Economizer Mode is enabled when the *Outdoor Air Enthalpy* falls below Return Air Enthalpy and the *Outdoor Air Temperature Active* is below 80°F. *Economizer Mode* continues with a deadband of 3 BTU/lb, and 1°F for temperature. If the unit is not in *Free Cooling Mode* during *Economizer Mode*, the unit opens the outdoor air damper to the *Outdoor Air Damper Maximum Position Setpoint*. Mechanical cooling will not be locked out unless the unit is in *Free Cooling Mode*.

Refer to Multi-State Value *Economizer System Status* to determine the active status for the economizing.

Free Cooling Mode is enabled when the unit is in *Economizer Mode* and the *Outdoor Air Temperature Active* is cooler than five degrees below the *Discharge Air Temperature Setpoint Active*. During *Free Cooling Mode*, mechanical cooling is locked out and the unit adjusts the outdoor air damper position to maintain the *Discharge Air Temperature Setpoint Active*.

Ventilation Mode

Discharge Air Control

Ventilation Mode is enabled when the *Outdoor Air Temperature Active* is between the *Outdoor Air Cooling Enable Setpoint* and the *Outdoor Air Heating Enable Setpoint*. During *Ventilation Mode*, heating and cooling is locked out and the unit supplies un-conditioned air. *Ventilation Mode* is locked out whenever the unit is in *Dehumidification Mode*.

Multi-Zone VAV Control

Ventilation Mode locked out.

Space Control

Ventilation Mode is enabled when the *Outdoor Air Temperature Active* and the *Space Temperature Active* is within two degrees of the *Space Temperature Setpoint Active*. During *Ventilation Mode*, heating and cooling is locked out and the unit supplies un-conditioned air. *Ventilation Mode* is locked out whenever the unit is in *Dehumidification Mode*.

Single Zone VAV Control

Ventilation Mode is enabled when the *Outdoor Air Temperature Active* and the *Space Temperature Active* is within two degrees of the *Space Temperature Setpoint Active*. During *Ventilation Mode*, heating and cooling is locked out, the supply fan goes to minimum air flow, and the unit supplies un-conditioned air. *Ventilation Mode* is locked out whenever the unit is in *Dehumidification Mode*.

Primary Heating Mode

Discharge Air Control

Heating Mode is enabled whenever the *Outdoor Air Temperature Active* is below the *Outdoor Air Heating Enable Setpoint*. During Heating Mode, *Heat Capacity* is adjusted to maintain the *Discharge Air Temperature Local* to *Discharge Air Temperature Setpoint Active*.

Multi-Zone VAV Control

Heating Mode is enabled according to the graph shown in [Figure 51, p. 82](#). Using the graph, setpoint is *Discharge Air Temperature Setpoint Active*, offset is 2°F, and temperature is *Discharge Air Temperature Local*. *Dehumidification Mode* takes priority over Heating Mode. During Heating Mode, *Heat Capacity* is adjusted to maintain the *Discharge Air Temperature Local* to *Discharge Air Temperature Setpoint Active*.

Space Control or Single Zone VAV Control, with Energy Recovery Wheel or has Mixed Air

Heating Mode is enabled according to the graph shown in [Figure 51, p. 82](#). Using the graph, setpoint is *Space Temperature Setpoint Active*, offset is *Occupied Offset*, and temperature is *Space Temperature Active*. *Dehumidification Mode* takes priority over Heating and Cooling Mode. During Heating Mode, *Heat Capacity* is adjusted to maintain the *Discharge Air Temperature Local* to *Discharge Air Temperature Setpoint Active*.

Space Control or Single Zone VAV Control with No Energy Recovery Wheel and 100% Outdoor Air

Heating Mode is enabled whenever the *Outdoor Air Temperature Active* falls below the *Outdoor Air Heating Enable Setpoint*. When this occurs, cooling and dehumidification is not allowed, regardless of space conditions.

When the *Outdoor Air Temperature Active* is above the *Outdoor Air Heating Enable*, but below the *Outdoor Air Cooling Enable Setpoint*, Heating Mode is enabled according to the graph shown in [Figure 51, p. 82](#). Using the graph, setpoint is *Space Temperature Setpoint Active*, offset is *Occupied Offset*, and temperature is *Space Temperature Active*.

During Heating Mode, *Heat Capacity* is adjusted to maintain the *Discharge Air Temperature Local* to *Discharge Air Temperature Setpoint Active*.

Figure 51. Heat cool mode arbitration graph.

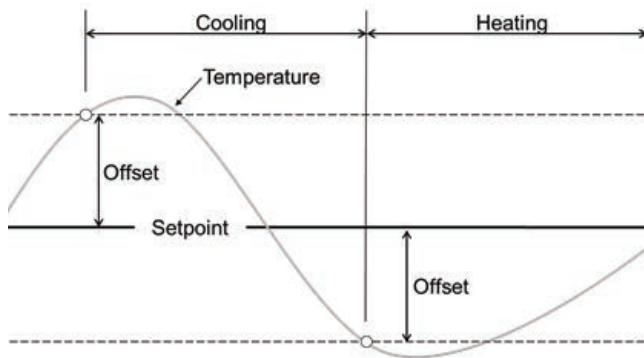

Gas Heat Ignition Failure

The unit monitors the status of the heater using *Heat On Off Status Local*. In the event of ignition failure, the unit will make three ignition attempts before displaying *Diagnostic: Heat Failure*. The unit is shut down when a heat failure occurs and resets four hours later to re-attempt ignition.

Heat Pump Heating Mode

Heat pump heating is enabled using the same criteria as Primary Heating Mode, except that heat pump is attempted first before using the primary heater. The same setpoints are used to adjust *Compressor Heating Capacity*. During heat pump operation the hot gas reheat is at 100%.

When the unit switches from heat pump to primary heating, *Auxiliary Heating Mode* changes to *Allowed*. *Auxiliary Heating Mode* is locked as *Allowed* for a minimum of fifteen minutes.

If the *Compressor Heating Capacity* is at 100%, and *Discharge Air Temperature Local* falls 3°F below the *Discharge Air Temperature Setpoint Active* for ten minutes, the unit toggles *Auxiliary Heating Mode* to

Allowed, *Outdoor Air Temperature Active* is recorded as *Heat Pump Fail Switch Point*. Heat pump operation is re-attempted when the temperature rises by 5°F.

The unit switches *Auxiliary Heating Mode* to *Allowed* when the *Outdoor Air Temperature Active* falls below the *Heat Pump Disable Temperature Setpoint* (adj. 0-60°F, default 25°F).

Water Source Heat Pump

Outdoor Coil Water Flow Status uses a differential pressure switch(es) across the supply and return to prove water flow. *Outdoor Coil Water Low Temperature Switch* uses temperature switch(es) on the return (35°F, water; 20°F, glycol). Heat pump operation is disabled if *Outdoor Coil Water Flow Status* goes Off for ten seconds, and immediately if the *Outdoor Coil Water Low Temperature Switch* is open.

Air Source Heat Pump – Demand Defrost Control

Defrosting of the outdoor coil may occur when the *Outdoor Air Temperature Active* is below 52°F and the *Outdoor Coil Refrigerant Temperature Local* (Circuit 1 or 2) is below 35°F. The unit monitors the condenser conditions, and *Defrost Mode* is enabled once there is frost accumulation. During *Defrost Mode* the reversing valve(s) are switched into the cooling position and the condenser fans are shut off. The primary heat will be enabled on units with gas or hot water heat. Units with electric or no heat will close the outdoor damper (if installed).

Cooling Mode

Discharge Air Control

Cooling Mode is enabled whenever the *Outdoor Air Temperature Active* rises above the *Outdoor Air Cooling Enable Setpoint*. The *Outdoor Air Temperature Active* must be above the *Outdoor Air Heating Enable Setpoint*. During Cooling Mode, *Cooling Capacity* is adjusted to maintain *Discharge Air Temperature Setpoint Active*.

Multi-Zone VAV Control

Cooling Mode is enabled according to the graph shown in [Figure 51, p. 82](#). Using the graph, setpoint is *Discharge Air Temperature Setpoint Active*, offset is 2°F, and temperature is *Discharge Air Temperature Local*. *Dehumidification Mode* takes priority over Cooling Mode. During Cooling Mode, *Cooling Capacity* is adjusted to maintain *Discharge Air Temperature Setpoint Active*.

Space Control or Single Zone VAV Control, with Energy Recovery Wheel or has Mixed Air

Cooling Mode is enabled according to the graph shown in [Figure 51, p. 82](#). Using the graph, setpoint is Space Temperature Setpoint Active, offset is Occupied Offset, and temperature is Space Temperature Active. Dehumidification Mode takes priority over Cooling Mode.

Space Control or Single Zone VAV Control with No Energy Recovery Wheel and 100% Outdoor Air

Cooling Mode is enabled whenever the Outdoor Air Temperature Active rises above the Outdoor Air Cooling Enable Setpoint. When this occurs, heating is not allowed, regardless of space conditions.

When the Outdoor Air Temperature Active is above the Outdoor Air Heating Enable, but below the Outdoor Air Cooling Enable Setpoint, Cooling Mode is enabled according to the graph shown in [Figure 51, p. 82](#). Using the graph, setpoint is Space Temperature Setpoint Active, offset is Occupied Offset, and temperature is Space Temperature Active.

Compressor Low Ambient Lockout

On units without head pressure control, the compressors will be locked out if the Outdoor Air Temperature Active falls below the Compressor Low Ambient Lockout Setpoint and there is a demand for cooling. When this occurs, the unit will display Compressor Low Ambient Lockout Active as an informational diagnostic.

Evaporator Frost Protection

Circuit 1 refrigeration pressure is monitored, and Cooling Capacity will be limited to prevent the indoor coil from freezing. If the unit has digital scroll on the second circuit, then both circuits will be monitored.

Dehumidification Mode

Outdoor Air Dewpoint is calculated using Outdoor Air Temperature Active and Outdoor Air Humidity Active.

For Dehumidification Temperature Active, OAN Rev. 6 (OANG) cabinet uses Discharge Air Dewpoint (calculated using Discharge Air Temperature Local and Discharge Air Humidity Local), all other cabinets use Indoor Coil Leaving Air Temperature Local.

Discharge Air Control

Dehumidification Mode is enabled whenever the Outdoor Air Dewpoint rises above the Outdoor Air Dewpoint Enable Setpoint. The Outdoor Air Temperature Active must be above Outdoor Air Heating Enable Setpoint.

During Dehumidification Mode, Cooling Capacity is adjusted to maintain the Dehumidification Temperature

Setpoint Active, which is written to by Dehumidification Temperature Setpoint (adjustable). Hot Gas Reheat Valve Command (if installed) is adjusted to maintain Discharge Air Temperature Setpoint Active.

Multi-Zone VAV Control

Dehumidification Mode is enabled whenever the Outdoor Air Dewpoint rises above the Outdoor Air Dewpoint Enable Setpoint.

During Dehumidification Mode, Cooling Capacity is adjusted to maintain the Dehumidification Temperature Setpoint Active, which is written to by Dehumidification Temperature Setpoint (adjustable). Hot Gas Reheat Valve Command (if installed) is adjusted to maintain Discharge Air Temperature Setpoint Active.

Space Control with Energy Recovery Wheel or has Mixed Air

Dehumidification Mode is enabled whenever the Space Dewpoint rises above the Space Dewpoint Calculated Enable Setpoint.

During Dehumidification Mode, the Dehumidification Temperature Setpoint Active is reset by comparing Space Dewpoint to Space Dewpoint Calculated Enable Setpoint minus 2°F. Hot Gas Reheat Valve Command (if installed) is adjusted to maintain Discharge Air Temperature Setpoint Active.

Space Control with No Energy Recovery Wheel and 100% Outdoor Air

Dehumidification Mode is enabled whenever the Space Dewpoint rises above the Space Dewpoint Calculated Enable Setpoint, or when the Outdoor Air Dewpoint rises above the Outdoor Air Dewpoint Enable Setpoint.

During Dehumidification Mode, the Dehumidification Temperature Setpoint Active is reset by comparing Space Dewpoint to Space Dewpoint Calculated Enable Setpoint minus 2°F. Hot Gas Reheat Valve Command (if installed) is adjusted to maintain Discharge Air Temperature Setpoint Active.

Hot Gas Reheat Purge

Hot Gas Reheat Purge Mode is initiated if the Hot Gas Reheat Valve Command is between 10% and 50% for thirty continuous minutes. During Hot Gas Reheat Purge Mode the signal first goes to 80% for one minute, then to 10% for one minute. The Hot Gas Reheat Valve Command returns to its previous position and will begin to modulate after a 30-second delay.

Supplemental Electric Reheat (Not Included in Standard Operation)

If the Hot Gas Reheat Valve Command is at 100%, the SCR electric heat is enabled Heat Capacity at 0%. If Heat Capacity rises above 0%, the Hot Gas Reheat Valve Command will be locked at 100% and the electric heat will



Sequence of Operation

be used to maintain the *Discharge Air Temperature Setpoint Active*.

Supplemental Hot Water Reheat

If the *Hot Gas Reheat Valve Command* is at 100%, the hot water valve is energized with *Heating Capacity* at 0%. If *Heat Capacity* rises above 0%, the *Hot Gas Reheat Valve Command* will be locked at 100% and the hot water will be used to maintain the *Discharge Air Temperature Setpoint Active*.

Hot Water Reheat (No Hot Gas Reheat Installed)

During *Dehumidification Mode*, the hot water valve is energized by enabling *Heat 1 Command*, *Heat Capacity* is adjusted to maintain *Discharge Air Temperature Setpoint Active*.

Exhaust Fan Operation

With Isolation Exhaust Fan Damper(s)

After completing the Supply Fan Starting Sequence, *Exhaust Damper Open Close Command* is enabled. Once the *Exhaust Damper End Switch* has proven, *Exhaust Fan Start Stop Command* is enabled.

Without Isolation Exhaust Fan Dampers

After completing the Supply Fan Starting Sequence, *Exhaust Fan Start Stop Command* is enabled.

With Modulating OA/RA Dampers

Exhaust fan speed is controlled to *Duct/Space Pressure Setpoint*.

ECM Exhaust with 2-Position OA Damper

Using the Exhaust Air Flow Active from the exhaust fan piezo reading, the unit controls exhaust fan speed to a constant volume of according to the *Exhaust Air Flow Setpoint*.

VFD Exhaust with 2-Position OA Damper

The exhaust fan controls to a constant speed using *PEVFD Setpoint*.

Energy Recovery Wheel Operation (ERV)

The *Energy Recovery Wheel Start Stop Command* is enabled whenever there is a call for exhaust fan. During *Ventilation Mode* or *Economizer Mode* the ERV is disabled, except during the cleaning cycle, which occurs for two minutes every thirty minutes.

During cooling operation, the *Energy Recovery Exhaust Air Bypass Position Command* is locked at 0% (closed position) for full energy recovery. During heating

operation, the position is modulated to maintain the *Discharge Air Temperature Setpoint Active* for variable effectiveness capacity control. Once the bypass damper becomes fully closed, the primary heater will be engaged.

Energy Wheel Without VFD

The unit prevents frost accumulation on the ERV by measuring the *Exhaust Leaving Temperature Local*. The *Energy Recovery Outdoor Air Bypass Position Command* is modulated open to maintain 15°F for the exhaust temperature. Above this temperature, the bypass damper will remain at 0% signal (closed) when the ERV is in operation.

Energy Wheel With VFD

The unit prevents frost accumulation on the ERV by measuring the *Exhaust Leaving Temperature Local*. Initially the ERV speed is reduced to maintain 15°F for the exhaust temperature. If the ERV speed is at minimum, but the exhaust temperature remains below 15°F, the unit will maintain the temperature by modulating the *Energy Recovery Outdoor Air Bypass Position Command* open. During normal operation, the VFD is at 100% (full speed) and the bypass damper is at 0% (closed).

Additional Features

Electric Pre-Heat

Pre-Heat Enable is engaged whenever the *Exhaust Leaving Temperature Local* falls below 20°F, with a deadband of 5°F. The pre-heater is shut off if the *Preheat Leaving Temperature Local* rises above 90°F.

Space Thumbwheel Input

Space Control and Single Zone VAV

With a space thumbwheel installed, the *Occupied Heating Setpoint* and *Occupied Cooling Setpoint* is replaced with a single setpoint from the input *Space Temperature Setpoint Local*. The occupancy override button will override *Occupancy Request* to Occupied for two hours from the time it was pressed.

Split Exhaust and Return Air Path

When a unit is equipped with separate paths for the return and exhaust air, there will be a damper separating the two, and the powered exhaust shall not run below the minimum required speed to ensure exhaust air does not contaminate the supply air. A differential pressure sensor is used across the damper to verify a negative pressure on the exhaust side. Exhaust fan will be enabled during unoccupied mode. During *Economizer Mode* the damper between the two air paths will open, the return damper will close complete, and the outdoor damper will open to 100%.

Outdoor Airflow Monitoring

Units with *Outdoor Air Flow Local In Service* and Modulating Dampers installed will modulate the *Outdoor Air Damper Position Command* the *Outdoor Air Minimum Flow Setpoint*. Damper position is restricted between the *Outdoor Air Damper Minimum Position Setpoint* and *Outdoor Air Damper Maximum Position Setpoint*.

Optional Field Enabled Features

Demand Control CO2 Ventilation

Modulating dampers are required for CO2 control. The unit will modulate the *Outdoor Air Damper Position Command* to maintain *Space CO2 Concentration Local* to *Space Concentration Setpoint*. The CO2 concentration can also be communicated to *Space CO2 Concentration BAS*. CO2 Concentration must be field provided and installed.

Exhaust Fan Tracking

To enable exhaust fan tracking to the supply fan speed, set *Exhaust Fan Tracking Offset Setpoint* to In Service and adjust to the desired value (%). Putting this point In Service will override all other default speed control for the exhaust fan.

Static Pressure Control for Exhaust Fan

To enable exhaust fan control for a static pressure setpoint, set *Return Duct/Space Pressure Local* to In Service. The default input for this reading is XM70.2.U112, but the point can be configured to any open input on the controller. The unit will modulate the *Exhaust Fan Speed Output Command* to the *Return Duct/Space Pressure Local*.

If a setpoint less than 0.25" WC is desired. It's recommended to use a transducer that has a range of -0.5" WC to 0.5" WC.

Unoccupied Operation

To enable heating, cooling, and dehumidification during unoccupied operation, the BV *Allow Unoccupied Operation* must be set as Allowed. Space conditions must be communicated via BAS or a hardwire space/temperature humidity sensor.

Starting Sequence

Unoccupied starting sequence begins when the Unoccupied Heating, Cooling, or *Dehumidification Mode* is enabled. Otherwise, the unit shall remain dormant with the supply fan disabled. Supply Fan Startup sequence is identical to occupied operation.

With Return Air Damper Installed

The outdoor air damper will be commanded to close, and the return air damper will open. If the unit is under Economizer conditions as described under the occupied

section the *Outdoor Air Damper Position Command* will open to the *Outdoor Air Damper Maximum Position Setpoint*.

No Return Air Damper Installed

Identical to occupied starting sequence.

Unoccupied Heating Mode

Unoccupied Heating Mode is enabled when the *Space Temperature Active* falls below the *Unoccupied Heating Enable Setpoint*. During *Unoccupied Heating Mode* the unit will run the heat to maintain 90°F for the discharge air temperature. *Unoccupied Heating Mode* is disabled when the *Space Temperature Active* rises 2°F above the *Unoccupied Heating Setpoint*.

Unoccupied Dehumid Mode

When there is no call for *Unoccupied Heating Mode*, *Unoccupied Dehumid Mode* is enabled when the *Space Dewpoint* rises above the *Unoccupied Dewpoint Enable Setpoint*. During *Unoccupied Dehumid Mode* the unit will run the cooling to maintain 45°F for the evaporator leaving temperature and reheat to 50°F for the discharge air temperature. *Unoccupied Dehumid Mode* is disabled when the *Space Dewpoint* rises 2°F above the *Unoccupied Dewpoint Enable Setpoint*.

Unoccupied Cooling Mode

When there is no call for *Unoccupied Heating Mode* or *Unoccupied Dehumid Mode*, *Unoccupied Cooling Mode* is enabled when the *Space Temperature Active* rises above the *Unoccupied Cooling Enable Setpoint*. During *Unoccupied Cooling Mode* the unit will run the cooling to maintain 50°F for the discharge air temperature. *Unoccupied Cooling Mode* is disabled when the *Space Temperature Active* rises 2°F above the *Unoccupied Cooling Enable Setpoint*.

Diagnostics

The following list contains the diagnostics indicated by Binary Values or Binary Inputs. These are typically determined in the background of the program, and the status is written to these points.

Analog Inputs, Analog Values, or other points may also show alarms, which typically indicates that they are outside of the normal range or that communication to the device has been lost.

Energy Wheel with Optional Rotation Sensor

Units equipped with an optional rotation sensor detects rotation status using a proximity sensor that detects movement of the "pie" sections. If *Energy Recovery Wheel Start Stop Command* is enabled, but the *Energy Recovery Wheel Rotation Status Local* remains Off for five minutes, *Diagnostic: Energy Recovery Wheel Rotation Failure* will be displayed. This diagnostic is auto reset when rotation status is detected.



Sequence of Operation

Condensate Detection Input will display a fault when the switch located in the condensate pan for the indoor coil has tripped.

Emergency Stop will display a fault if the Emergency Stop circuit is opened. Line 76 on the wiring diagram shows the circuit to energize the Emergency Stop Relays. The unit is shut down when this diagnostic occurs, including the supply fan.

Compressor Low Ambient Lockout Active will display a fault if there is a demand for cooling according to the setpoints, but the *Outdoor Air Temperature Active* is below the *Compressor Low Ambient Lockout Setpoint* and the unit does not have active head pressure control.

These diagnostic locks out compressor operation.

Diagnostic: Compressor [1, 2,...] Run Failure is displayed when there is a command for a compressor but there is no active status for the compressor. Compressor status is indicated using the NC contact on the compressor auxiliary contactor.

Upon an initial call for a compressor, there is a five minute and thirty second delay of no run status before an alarm is indicated. If there is five minutes of continuous operation with the run status, there is a thirty second delay before the alarm is displayed.

The program will disable the output for that compressor if there is run status alarm indicated. The diagnostic is cleared when there is an alarm reset or the diagnostic has been active for 3 hours.

Diagnostic: Compressor Fail Unit Lockout is displayed when there is a run failure diagnostic for one of the compressors and the unit is supplying unsatisfactory conditions for ten minutes. Unsatisfactory conditions are identified by the *Discharge Air Temperature Local* is 2°F above or below the *Discharge Air Temperature Setpoint Active* during Heat Pump Heating or Cooling Mode, or when the *Dehumidification Temperature Active* is 2°F below the *Dehumidification Temperature Setpoint Active* during *Dehumidification Mode*.

The unit is shut down when this diagnostic occurs, including the supply fan. The diagnostic can be cleared with an alarm reset and will auto-reset once the compressor run failure diagnostic is cleared.

Diagnostic: Condensate Overflow Unit Lockout is displayed when the *Condensate Detection Input* has failed, and the unit is supplying unsatisfactory conditions for five minutes. The unsatisfactory conditions use the same criteria as the *Diagnostic: Compressor Fail Unit Lockout*.

The unit is shut down when this diagnostic occurs, including the supply fan. The diagnostic will auto-reset five minutes after the condensate diagnostic has cleared.

Diagnostic: Heat Failure is displayed after three failed attempts to ignite the primary indirect fired gas heater within a four-hour period. The unit is shut down when this diagnostic occurs, including the supply fan

Diagnostic: [High, Low] Discharge Air Temp Lockout is displayed when the *Discharge Air Temperature Local* is [above 128°F, below 35°F] for a duration of 10 minutes. The diagnostic is manual reset using *Alarm Reset*.

Diagnostic: Liquid Line Refrigerant Pressure Circuit [1,2] Source Failure is displayed when the respective circuit is on (indicated by the compressor run status) and the *Liquid Line Refrigerant Pressure Circuit [1,2]* falls outside of the range of 150-650 PSI for a duration of two minutes. When this occurs, the condenser fans will run at 100%

Diagnostic: Low Outdoor Coil Water Flow is displayed if the supply fan is running but the *Outdoor Coil Water Flow Status* indicates that there is no flow for 20-seconds. The compressors will be prevented from operating when this diagnostic occurs and will auto-reset once the flow returns.

The *Outdoor Coil Water Flow Status* is indicated using a differential pressure switch across the inlet and outlet of the water coils.

Diagnostic: Outdoor Coil Water Temperature Low is displayed if the supply fan is running but the *Outdoor Coil Water Low Temperature Switch* indicates that the water temperature is too low. The compressors will be prevented from operating when this diagnostic occurs and will auto-reset once the temperature switch closes.

The temperature switch is located on the water return and the switch opens at 35°F for water, 20°F for glycol

Diagnostic: Low Refrigerant Suction Pressure Circuit [1,2] is displayed when the respective circuit is on (indicated by the compressor run status) and the *Suction Line Refrigerant Pressure Circuit [1,2] Local* falls below 85 PSI (55 PSI for heat pump heating) for two continuous minutes. The diagnostic auto clears when the pressure returns to normal.

Diagnostic: Outdoor Air Damper End Switch is displayed when *Outdoor Air Damper Open Close Command* is On, but the *Outdoor Air Damper End Switch* does not prove for 3-minutes. The diagnostic is reset using *Alarm Reset* or when the end switch is proven.

Diagnostic: Return Duct/Space Pressure Setpoint Range is displayed when the *Return Duct/Space Pressure Setpoint* is set within 20% of the maximum limit of the *Return Duct/Space Pressure Local*. If the setpoint is set too close to the maximum range of the sensor, it will not be able to recognize when it's outside of the operating range.

Diagnostic: Duct Static Pressure Setpoint Range is displayed when the *Duct Static Pressure Setpoint BAS* is set within 20% of the maximum limit of the *Duct Static Pressure Local*. If the setpoint is set too close to the maximum range of the sensor, it will not be able to recognize when it's outside of the operating range.

Diagnostic: Supply Fan Failure is displayed when the *Supply Fan Start Stop Command* is On, but the *Supply Fan Status* does not prove for two minutes. The diagnostic requires a manual reset using *Alarm Reset*.

Sensor Source Failures

The following diagnostics are displayed when the respective sensor reading is outside of the expected range, indicating that the sensor may be faulty. Refer to the points list for expected ranges of each input.

In some cases, a BAS point is In Service, and will take priority over a hardwired input. If the point was inadvertently put In Service, and the BAS is either not writing a value or the value is outside of the expected range, then the program will first attempt to fall back to a hardwired input before displaying a source failure diagnostic.

- Diagnostic: Dehumidification Temperature Sensor Source Failure*
- Diagnostic: Discharge Air Humidity Source Failure
- Diagnostic: Discharge Air Temperature Source Failure
- Diagnostic: Duct Static Pressure Source Failure
- Diagnostic: Outdoor Air Flow Sensor Source Failure
- Diagnostic: Outdoor Air Humidity Source Failure
- Diagnostic: Outdoor Air Temperature Source Failure
- Diagnostic: Return Duct/Space Pressure Source Failure
- Diagnostic: Space CO2 Source Failure
- Diagnostic: Space Humidity Source Failure
- Diagnostic: Space Temperature Source Failure

*The Dehumidification Temperature Sensor is the *Indoor Coil Leaving Air Temperature Local* on all cabinets except for the OANG (OAN Rev. 6). For the OANG cabinet, the sensor is the *Discharge Air Humidity Local*.

Economizer Fault Detection and Diagnostics

Not Economizing When It Should be Economizing is displayed when unit is in *Economizer Mode* and the *Outdoor Air Damper Position Status Local* is 20% below the *Outdoor Air Damper Position Command* for 20-minutes.

Damper Not Modulating is displayed if the *Outdoor Air Damper Position Status Local* is 20% below the *Outdoor Air Damper Position Command* for 20-minutes.

Mixed Air Low Limit Active is displayed when the unit is in *Economizer Mode* and the unit is limiting the *Outdoor Air Damper Position Command* to prevent the mixed air temperature from falling below 35°F. Units equipped with Class 1A dampers will use a sensor, *Mixed Air Temperature Local*. Otherwise, the unit will estimate the mixed air temperature using *Outdoor Air Temperature Active*, *Return Air Temperature Local*, and the *Outdoor Air Damper Position Command*.



Startup Form

Trane[®] Horizon[™] DOAS

Job Name	
Unit Serial Number	
Unit Tag	
Technician Name	
Horizon Tech Training Completed	<input type="checkbox"/> Yes <input type="checkbox"/> No Date Completed:
Startup Date	

To get a digital copy of this form, please email horizonstartup@kccmfg.com.

For further questions please contact the factory at 502-493-5757.

Pre-Startup Checklist

- Checked for visible shipping damage.
- Unit is level.
- All fans spin freely.
- All electrical connections tight.
- Interior cabinet inspected for damage or loose components.
- All field installed devices are installed.
- Clearances meet minimum requirements in IOM.
- Condensate drains and P-Traps installed.
- All doors open freely.
- Wiring schematics installed on front door.

- ☐ Verify Indoor Fan Failure Switch (OAB, or OAG cabinets with UC600 controls)
 1. Note the minimum of Analog Values labelled Supply Fan Air Flow Minimum Setpoint – Cooling Mode (AV59) and Supply Fan Air Flow Minimum Setpoint – Heating Mode (AV13).
 2. Override Analog Output labelled Supply Fan Speed Command (AO2) until the Supply Fan Air Flow Active (AV41) matches the value from step 1.
 3. Locate the Indoor Fan Failure Switch (IFFS) in the control section.
 - a. Labelled IFFS or two red wires labelled IFFS/464A.
 4. Slowly rotate IFFS switch clockwise (lightly tapping the IFFS after each full turn) until IFFR relay is not lit.
 5. Rotate IFFS switch ½ turn counterclockwise. IFFR relay should then be lit.
 6. Release Supply Fan Speed Command

- ☐ Verify Indoor Fan Failure Switch (OAD, OAK or OAN cabinets with UC600 controls and all units without UC600)
 1. Set the unit at minimum air flow:
 - a. For OAD, OAK or OAN with UC600, override Supply Fan Speed Command to 0%.
 - b. For all Units without UC600, have the controls contractor set the supply fan speed so that the air flow is at minimum.
 2. Locate the Indoor Fan Failure Switch (IFFS) in the control section.
 - a. Labelled IFFS or two red wires labelled IFFS/464A.
 3. Slowly rotate IFFS switch clockwise (lightly tapping the IFFS after each full turn) until IFFR relay is not lit.
 4. Rotate IFFS switch ½ turn counterclockwise. IFFR relay should then be lit.
 5. Release Supply Fan Speed Command override.

Voltages

Rated Voltage	Measured
Voltage L1-L2	
Voltage L1-L3	
Voltage L2-L3	
Voltage L1-G	
Voltage L2-G	
Voltage L3-G	
TNS2 Secondary Voltage	



Startup Form

Motor Data

Motor	Model Number	Rated HP/kW	Rated FLA	Running FLA		
				L1	L2	L3
Supply Fan 1						
Supply Fan 2						
Exhaust Fan 1						
Exhaust Fan 2						
Condenser Fan 1						
Condenser Fan 2						
Condenser Fan 3						
Condenser Fan 4						
Condenser Fan 5						
Condenser Fan 6						
ERV						

Compressor Data

	Model Number	Serial Number	Rated Amps	Running Amps		
1						
2						
3						
4						
5						
6						

Actuators

Actuator Name	Control	Operation Verified
Outdoor Air Damper Actuator	2-Position or 2-10 VDC	<input type="checkbox"/>
Return Air Damper Actuator	2-Position or 2-10 VDC	<input type="checkbox"/>
Exhaust Damper Actuator(s)	2-Position	<input type="checkbox"/>
Split Exhaust/Return Damper Actuator	2-Position	<input type="checkbox"/>
Outdoor Air ERV Bypass Damper Actuator	2-10 VDC	<input type="checkbox"/>
Exhaust Air ERV Bypass Damper Actuator	2-10 VDC	<input type="checkbox"/>
WSHP Water Valve Actuator(s)	2-10 VDC	<input type="checkbox"/>
Chilled Water Valve Actuator (Field Supplied)	-	<input type="checkbox"/>
Hot Water Valve Actuator (Field Supplied)	-	<input type="checkbox"/>

Refrigeration Startup

Test Procedures

Important: Cooling startup can only be completed if the OA temp is >65°F or <105°F. Heating startup can only be completed if OA temp is <90°F

1. Test each circuit independently.
2. Tandem or trio circuits must have all compressors on.
3. Set Digital Scroll/Variable Speed command to 100%*.
4. Outdoor Air Damper open, Return Air Damper closed.
5. Set hot gas reheat to 25%* (if installed).
6. Set outdoor air coil conditions.
 - a. Air Source Heat Pump or Standard DX.
 - i. Reduce condenser fan air flow until liquid line pressure is 375-400PSI.

- b. Water Source Heat Pump.
 - i. Verify proper water flow through water coil.

7. Adjust charge until subcooling is 10-15.
8. Record all readings.
9. Verify HGRH operational at 100%.
10. Heat Pumps: Switch reversing valve to heating, repeat steps 1-8 for heating mode except with hot gas reheat at 100%.
11. Repeat for Circuit 2.

Note: If saturated suction >67°F, you can test both circuits at the same time.

Units with variable speed compressor (VFD on compressor 1) must also be tested at 0% signal and 100% hot gas reheat.

		Circuit 1		Circuit 2		VS Test 2
		Cooling	Heating	Cooling	Heating	
		Outdoor Temp (°F)				
		Outdoor RH (%)				
		Hot Gas Reheat Signal (%)				
Discharge Line		Pressure (PSI)				
		Sat. Temp (°F)				
		Temp (°F)				
Suction Line		Pressure (PSI)				
		Sat. Temp (°F)				
		Temp (°F)				
		Superheat (°F)				
Liquid Line		Pressure (PSI)				
		Sat. Temp (°F)				
		Temp (°F)				
		Subcooling (°F)				
		Evaporator Leaving Temp (°F)				
WSHP Only		Entering Water Temp (°F)				
		Leaving Water Temp (°F)				
		Water Coil Pressure Drop (PSI)				



Startup Form

Indirect Fired Gas Heat Startup

Furnace Data

	Serial Number	Model Number
Furnace 1		
Furnace 2		
Furnace 3		

Gas Pressure Settings

	Measured Pressure	Natural Gas Settings	Propane Settings	
Incoming to Unit		7 – 14	11 – 14	in.H2O
Between On/Off & Mod. Valve		5	10.5	in.H2O
Stage 1 Manifold (Low Fire)		0.4	1.2	in.H2O
Stage 1 Manifold (High Fire)		3.5	8	in.H2O
Stage 2 Manifold		3.5	8	in.H2O
Stage 3 Manifold		3.5	8	in.H2O

Electric Heat Startup

Heater Data

		Primary Heater	Pre-Heater
Item Number			
Rated kW			
Rated Amps			
Running Amps	L1		
	L2		
	L3		

Programming and Commissioning

Program Control Type (MV-13)

Select the sequence of operation and whether the unit will operate with a Build Automation System (BAS) or as a standalone unit.

- Space Control
- Discharge Air Control
- Single Zone VAV
- Multi Zone VAV
- BAS Control
- Standalone Control

Description

Setpoints are pre-set at the factory using submittal data. It's highly recommended to compare the factory values to the customer's expectations to make sure it meets their requirements.

Review the Typical Setpoints on the next page and reference the Sequence of Operation for more detail.

Some of the setpoints have either a local version or a BAS version. If there are both versions of the points, then the BAS point will always take priority when it is set to In Service. Typically, these points are set Out of Service from the factory.

If possible, generate a Point Summary Report using Tracer TU after startup and submit that along with this startup report. The report is generated by going to Reports at the top left, Point Summary Report, and then Generate Report on the popup window. None of the checkboxes need to be checked.

Commissioning

Do not attempt to perform commissioning by putting points Out of Service and setting a value. The program looks for points that are In Service or Out of Service to change the operation.

Instead, override the analog and binary values to "trick" the unit into modes of operation. When commissioning is complete, release the override on these points to resume normal operation. It's recommended to use a timed override so that it will auto-release.

Example: The unit uses Discharge Air Control and the commissioning agent wants to see the unit enter Cooling Mode. You look through the setpoints and find that the Outdoor Air Cooling Enable Setpoint is 65°F.

To put the unit into Cooling Mode the Outdoor Air Temperature must be above this setpoint. You put the unit into Cooling Mode by overriding the Outdoor Air Temperature Active (AV76) at a priority of 8 (default for TD7) and set it above 65°F.



Startup Form

Typical Setpoints

#	BACnet Point Name	Setting	Default	Range	Units	Description
DISCHARGE AIR CONTROL						
AV-29	Outdoor Air Cooling Enable Setpoint		-	45–100	°F	When the Outdoor Air Temperature is above this setpoint, the unit will be locked into Cooling Mode.
AV-33	Outdoor Air Heating Enable Setpoint		-	15–75	°F	When the Outdoor Air Temperature is below this setpoint, the unit will be locked into Heating Mode (takes priority over Dehumidification Mode).
AV-10	Outdoor Air Dewpoint Enable Setpoint		-	45–100	°F	When the Outdoor Air Dewpoint is above this setpoint, the unit will be locked into Dehumidification Mode (takes priority over Cooling Mode).
AV-30	Discharge Air Cooling Setpoint BAS		60	45–90	°F	Discharge air setpoint during Cooling and Dehumidification Mode.
AV-32	Discharge Air Heating Setpoint BAS		65	45–100	°F	Discharge air setpoint during Heating Mode.
AV-67	Discharge Air Temperature Setpoint BAS		55	40–125	°F	Discharge air setpoint used during Heating, Cooling, and Dehumidification Mode. Factory defaulted Out of Service, put In Service to use.
SPACE CONTROL AND SINGLE ZONE VAV						
AV-87	Space Humidity Setpoint		45	0–100	%	Temperature setpoint and this setpoint is used to calculate a Space Dewpoint Setpoint, which puts the unit into Dehumidification Mode.
AV-01	Occupied Cooling Setpoint		72	55–85	°F	Space cooling setpoint used in occupied mode.
AV-02	Occupied Heating Setpoint		70	55–85	°F	Space heating setpoint used in occupied mode.
AV-25	Space Temperature Setpoint BAS		72	62–80	°F	Communicated space temperature setpoint (overwrites Occupied Cooling and Heating Setpoints). Factory defaulted Out of Service, put In Service to use.
MULTI ZONE VAV						
AV-10	Outdoor Air Dewpoint Enable Setpoint		55	45–100	°F	When the Outdoor Air Dewpoint is above this setpoint, the unit will be locked into Dehumidification Mode (takes priority over Cooling Mode).
AV-30	Discharge Air Cooling Setpoint BAS		60	45–90	°F	Discharge air setpoint during Cooling and Dehumidification Mode.
AV-32	Discharge Air Heating Setpoint BAS		65	45–100	°F	Discharge air setpoint during Heating Mode.
AV-67	Discharge Air Temperature Setpoint BAS		55	40–125	°F	Discharge air setpoint used during Heating, Cooling, and Dehumidification Mode. Factory defaulted Out of Service, put In Service to use.
AIR BALANCE						
AV-39	Supply Fan Air Flow Setpoint		Varies	0–25000	cfm	Setpoint used to control the supply fan for constant volume. Only used on OAB and OAG cabinets (not VAV).
AV-46	Duct Static Pressure Setpoint BAS		1.5	-1–6	in.H2O	Setpoint used to control supply fan to static pressure. Factory default range is 0-2"WC, but can be re-configured for 0-5"WC.
AV-40	Exhaust Fan Speed Setpoint BAS		80	0–100	%	Setpoint used for constant speed exhaust fan. Used on OAD, OAK, and OAN cabinets that have exhaust, but do not have modulating OA/RA dampers.
AV-57	Exhaust Fan Air Flow Setpoint		Varies	0–25000	cfm	Setpoint used for constant volume exhaust fan control. Used on OAB and OAG cabinets that have exhaust, but do not have modulating OA/RA dampers.
AV-48	Outdoor Air Damper Minimum Position Setpoint		Varies	0–100	%	Setpoint used to limit the outdoor air damper position during all operation. Typically adjusted during air balance. Factory set at an estimate based on submittal data.

Final Notes

Is there something missing or do you have recommendations on improvements?

Note here if the outdoor air temperature is too low for cooling testing.

Submit completed form to horizonstartup@kccmfg.com
Include serial number and job name in subject of email.

Trane - by Trane Technologies (NYSE: TT), a global climate innovator - creates comfortable, energy efficient indoor environments for commercial and residential applications. For more information, please visit trane.com or tranetechnologies.com.

Trane has a policy of continuous product and product data improvement and reserves the right to change design and specifications without notice. We are committed to using environmentally conscious print practices.