

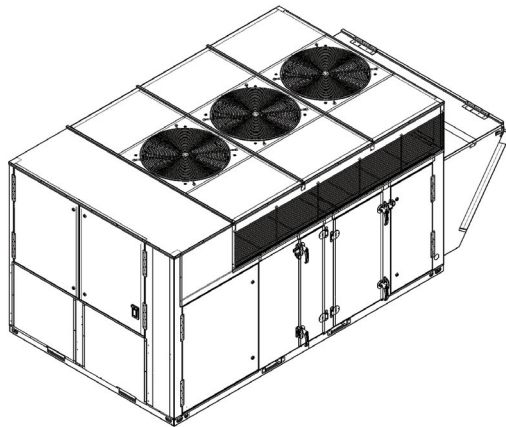

# Installation, Operation, and Maintenance

## Horizon™ Outdoor Air Unit

### Direct Gas-Fired



**Model:** OAB, OAG

**Important:** Proper execution of the tasks outlined in this Installation, Operation, and Maintenance manual require and assume the technician has been certified as a start up technician for the Horizon Outdoor Air unit. This includes working knowledge of the Tracer TU program.

#### **⚠ SAFETY WARNING**

Only qualified personnel should install and service the equipment. The installation, starting up, and servicing of heating, ventilating, and air-conditioning equipment can be hazardous and requires specific knowledge and training. Improperly installed, adjusted or altered equipment by an unqualified person could result in death or serious injury. When working on the equipment, observe all precautions in the literature and on the tags, stickers, and labels that are attached to the equipment.

#### **⚠ AVERTISSEMENT DE SÉCURITÉ**

L'installation et l'entretien de cet équipement doivent être assurés exclusivement par du personnel qualifié. L'installation, la mise en service et l'entretien d'équipements de chauffage, de ventilation et de climatisation (CVC) présentent un danger et requièrent des connaissances et une formation spécifiques. Une installation, un réglage ou une modification inappropriés d'un équipement par une personne non qualifiée peut provoquer des blessures graves, voire la mort. Lors de toute intervention sur l'équipement, respectez les consignes de sécurité figurant dans la documentation, ainsi que sur les pictogrammes, autocollants et étiquettes apposés sur l'équipement.



# Introduction

Read this manual thoroughly before operating or servicing this unit.

## Warnings, Cautions, and Notices

Safety advisories appear throughout this manual as required. Your personal safety and the proper operation of this machine depend upon the strict observance of these precautions.

The three types of advisories are defined as follows:

- ⚠ WARNING** Indicates a potentially hazardous situation which, if not avoided, could result in death or serious injury.
- ⚠ CAUTION** Indicates a potentially hazardous situation which, if not avoided, could result in minor or moderate injury. It could also be used to alert against unsafe practices.
- NOTICE** Indicates a situation that could result in equipment or property-damage only accidents.

## Important Environmental Concerns

Scientific research has shown that certain man-made chemicals can affect the earth's naturally occurring stratospheric ozone layer when released to the atmosphere. In particular, several of the identified chemicals that may affect the ozone layer are refrigerants that contain Chlorine, Fluorine and Carbon (CFCs) and those containing Hydrogen, Chlorine, Fluorine and Carbon (HCFCs). Not all refrigerants containing these compounds have the same potential impact to the environment. Trane advocates the responsible handling of all refrigerants.

## Important Responsible Refrigerant Practices

Trane believes that responsible refrigerant practices are important to the environment, our customers, and the air conditioning industry. All technicians who handle refrigerants must be certified according to local rules. For the USA, the Federal Clean Air Act (Section 608) sets forth the requirements for handling, reclaiming, recovering and recycling of certain refrigerants and the equipment that is used in these service procedures. In addition, some states or municipalities may have additional requirements that must also be adhered to for responsible management of refrigerants. Know the applicable laws and follow them.

**⚠ WARNING**

**Proper Field Wiring and Grounding Required!**

Failure to follow code could result in death or serious injury. All field wiring **MUST** be performed by qualified personnel. Improperly installed and grounded field wiring poses **FIRE** and **ELECTROCUTION** hazards. To avoid these hazards, you **MUST** follow requirements for field wiring installation and grounding as described in **NEC** and your local/state/national electrical codes.

**⚠ AVERTISSEMENT**

**Câblage sur site et mise à la terre corrects nécessaires!**

Le non-respect de la réglementation peut entraîner des blessures graves, voire mortelles. Il est **IMPÉRATIF** de confier l'ensemble du câblage sur site à un électricien qualifié. Un câblage sur site mal installé ou mal mis à la terre constitue des risques **D'INCENDIE** et **D'ÉLECTROCUTION**. Pour éviter ces risques, il est **IMPÉRATIF** de respecter les obligations en matière de pose de câblage sur site et de mise à la terre tel que stipulé dans les règles du **NEC** et dans les réglementations électriques locales/nationales.

**⚠ WARNING****Personal Protective Equipment (PPE) Required!**

Failure to wear proper PPE for the job being undertaken could result in death or serious injury. Technicians, in order to protect themselves from potential electrical, mechanical, and chemical hazards, **MUST** follow precautions in this manual and on the tags, stickers, and labels, as well as the instructions below:

- Before installing/servicing this unit, technicians **MUST** put on all PPE required for the work being undertaken (Examples; cut resistant gloves/sleeves, butyl gloves, safety glasses, hard hat/bump cap, fall protection, electrical PPE and arc flash clothing). **ALWAYS** refer to appropriate Safety Data Sheets (SDS) and OSHA guidelines for proper PPE.
- When working with or around hazardous chemicals, **ALWAYS** refer to the appropriate SDS and OSHA/GHS (Global Harmonized System of Classification and Labeling of Chemicals) guidelines for information on allowable personal exposure levels, proper respiratory protection and handling instructions.
- If there is a risk of energized electrical contact, arc, or flash, technicians **MUST** put on all PPE in accordance with OSHA, NFPA 70E, or other country-specific requirements for arc flash protection, **PRIOR** to servicing the unit. **NEVER PERFORM ANY SWITCHING, DISCONNECTING, OR VOLTAGE TESTING WITHOUT PROPER ELECTRICAL PPE AND ARC FLASH CLOTHING. ENSURE ELECTRICAL METERS AND EQUIPMENT ARE PROPERLY RATED FOR INTENDED VOLTAGE.**

**⚠ AVERTISSEMENT****Équipements de protection individuelle (EPI) obligatoires!**

En cas d'équipement de protection individuelle inadapté au travail entrepris, les techniciens s'exposent à des risques de blessures graves voire mortelles. Afin de se prémunir d'éventuels risques électriques, mécaniques et chimiques, les techniciens **DOIVENT** respecter les consignes préconisées dans le présent manuel, sur les étiquettes et les autocollants, ainsi que les instructions suivantes :

- Avant d'installer/réparer cette unité, les techniciens doivent **IMPÉRATIVEMENT** porter tout l'équipement de protection individuelle (EPI) recommandé pour le travail entrepris (exemples: gants/manchons résistants aux coupures, gants en caoutchouc butyl, lunettes de protection, casque de chantier/antichoc, protection contre les chutes, EPI pour travaux électriques et vêtements de protection contre les arcs électriques). Consulter **SYSTÉMATIQUEMENT** les fiches de données de sécurité et les directives de l'OSHA pour connaître la liste des EPI adaptés.
- Lors d'une intervention avec ou à proximité de produits chimiques dangereux, consulter **SYSTÉMATIQUEMENT** les fiches de données de sécurité appropriées et les directives de l'OSHA/du SGH (système général harmonisé de classification et d'étiquetage des produits chimiques) afin d'obtenir des renseignements sur les niveaux admissibles d'exposition personnelle, la protection respiratoire adaptée et les recommandations de manipulation.
- En cas de risque d'éclair, d'arc électrique ou de contact électrique avec un équipement électrique sous tension, et **AVANT** de réparer l'unité, les techniciens doivent **IMPÉRATIVEMENT** porter tout l'équipement de protection individuelle (EPI) conformément à l'OSHA, à la norme NFPA 70E ou à toute autre exigence propre au pays pour la protection contre les arcs électriques. **NE JAMAIS COMMUTER, DÉBRANCHER ou EFFECTUER DE TEST DE TENSION SANS PORTER UN EPI POUR TRAVAUX ÉLECTRIQUES OU UN VÊTEMENT DE PROTECTION APPROPRIÉ CONTRE LES ARCS ÉLECTRIQUES. IL CONVIENT DE S'ASSURER QUE LES COMPTEURS ET ÉQUIPEMENTS ÉLECTRIQUES CORRESPONDENT À LA TENSION NOMINALE PRÉVUE.**

**⚠ WARNING****Follow EHS Policies!**

Failure to follow instructions below could result in death or serious injury.

- All Trane personnel must follow the company's Environmental, Health and Safety (EHS) policies when performing work such as hot work, electrical, fall protection, lockout/tagout, refrigerant handling, etc. Where local regulations are more stringent than these policies, those regulations supersede these policies.
- Non-Trane personnel should always follow local regulations.

**⚠ AVERTISSEMENT****Respecter les politiques EHS !**

Le non-respect des consignes suivantes peut être à l'origine de blessures graves, voire mortelles.

- Tous les membres du personnel externes à l'entreprise sont tenus de respecter les règles établies par l'entreprise en matière d'environnement, de santé et de sécurité (EHS) lors d'une intervention, notamment en cas de travail à chaud, risque de choc électrique et de chute, procédures de verrouillage / déclassement, manipulation de fluide frigorigène, etc. Si les réglementations locales sont plus strictes que les règles imposées par le groupe, elles deviennent prioritaires.
- Le personnel extérieur à l'entreprise est, quant à lui, systématiquement tenu d'observer les réglementations en vigueur à l'échelle locale.

**⚠ WARNING****Refrigerant under High Pressure!**

Failure to follow instructions below could result in an explosion which could result in death or serious injury or equipment damage. System contains oil and refrigerant under high pressure. Recover refrigerant to relieve pressure before opening the system. See unit nameplate for refrigerant type. Do not use non-approved refrigerants, refrigerant substitutes, or refrigerant additives.

**⚠ AVERTISSEMENT****Fluide frigorigène sous haute pression!**

Tout manquement aux instructions indiquées ci-dessous peut provoquer une explosion pouvant causer des blessures graves voire mortelles ou des dommages matériels. Le système contient de l'huile et du fluide frigorigène sous haute pression. Avant d'ouvrir le circuit, récupérez le fluide frigorigène pour éliminer toute pression dans le circuit. Consultez la plaque constructeur de l'unité pour connaître le type de fluide frigorigène employé. Utilisez uniquement des fluides frigorigènes, substitués et additifs agréés.

**⚠ WARNING****Hazard of Explosion and Deadly Gases!**

Failure to follow all proper safe refrigerant handling practices could result in death or serious injury. Never solder, braze or weld on refrigerant lines or any unit components that are above atmospheric pressure or where refrigerant may be present. Always remove refrigerant by following the guidelines established by the EPA Federal Clean Air Act or other state or local codes as appropriate. After refrigerant removal, use dry nitrogen to bring system back to atmospheric pressure before opening system for repairs. Mixtures of refrigerants and air under pressure may become combustible in the presence of an ignition source leading to an explosion. Excessive heat from soldering, brazing or welding with refrigerant vapors present can form highly toxic gases and extremely corrosive acids.

**⚠ AVERTISSEMENT****Risque d'explosion et gaz mortels!**

Le non-respect de toutes les consignes de manipulation des fluides frigorigènes peut entraîner la mort ou des blessures graves. N'effectuez en aucune circonstance des opérations de brasage ou de soudage sur des conduites de fluide frigorigène ou des composants de l'unité sous pression ou pouvant contenir du fluide frigorigène. Récupérez systématiquement le fluide frigorigène en respectant les directives de la loi américaine sur la propreté de l'air (Agence fédérale pour l'environnement) ou toute autre réglementation nationale ou locale en vigueur. Après la récupération du fluide frigorigène, utilisez de l'azote déshydraté pour ramener le système à la pression atmosphérique avant de l'ouvrir pour procéder aux réparations. Les mélanges de fluide frigorigène et d'air sous pression peuvent devenir combustibles en présence d'une source d'inflammation et provoquer une explosion. La chaleur excessive découlant de travaux de soudage ou de brasage associée à la présence de vapeurs de fluide frigorigène peut entraîner la formation de gaz hautement toxiques et d'acides extrêmement corrosifs.



**⚠ WARNING****Hazard of Explosion and Deadly Gases!**

Failure to follow instructions could result in death or serious injury.

If you smell gas:

1. Open windows.
2. Don't touch electrical switches.
3. Extinguish any open flame.
4. Immediately call your gas supplier.

**⚠ AVERTISSEMENT****Risque d'explosion et gaz mortels!**

Le non-respect de toutes les consignes de sécurité ci-dessous peut entraîner la mort ou des blessures graves.

Si vous sentez une odeur de gaz:

1. Ouvrez les fenêtres.
2. Ne touchez à aucun interrupteur.
3. Éteignez toute flamme nue.
4. Avertissez immédiatement votre fournisseur de gaz.

**⚠ WARNING****Hazardous Service Procedures!**

Improper installation, adjustment, alteration, service or maintenance can cause property damage, injury or death. Read the installation, operating and maintenance instructions thoroughly before installing or servicing this equipment.

**⚠ AVERTISSEMENT****Procédures d'entretien dangereuses!**

Une installation, un réglage, une modification, une réparation ou un entretien incorrect peut entraîner des dommages matériels, des blessures ou la mort. Lisez attentivement les instructions d'installation, de fonctionnement et d'entretien avant de procéder à l'installation ou à l'entretien de cet équipement.

**⚠ WARNING****Hazard of Explosion and Deadly Gases!**

Failure to follow instructions could result in death or serious injury.

The use and storage of gasoline or other flammable vapors and liquids in open containers in the vicinity of this appliance is hazardous.

**⚠ AVERTISSEMENT****Risque d'explosion et gaz mortels!**

Le non-respect de toutes les consignes de sécurité ci-dessous peut entraîner la mort ou des blessures graves.

Il est dangereux d'utiliser ou d'entreposer de l'essence ou autres liquides ou vapeurs inflammables dans des récipients ouverts à proximité de cet appareil.

## Copyright

This document and the information in it are the property of Trane, and may not be used or reproduced in whole or in part without written permission. Trane reserves the right to revise this publication at any time, and to make changes to its content without obligation to notify any person of such revision or change.

## Trademarks

All trademarks referenced in this document are the trademarks of their respective owners.



# Table of Contents

Model Number Descriptions . . . . .	9	Condensate Drain Configuration . . . . .	20
Horizon Outdoor Air Unit . . . . .	9	Filter Installation . . . . .	21
General Information . . . . .	12	Field Installed Power Wiring . . . . .	21
Overview of Manual . . . . .	12	Main Unit Power . . . . .	22
Model Number Description . . . . .	12	Standard Wiring . . . . .	22
Unit Nameplate . . . . .	12	Voltage Imbalance . . . . .	23
Compressor Nameplate . . . . .	12	Electrical Phasing (Three-Phase Motors) . . . . .	24
Unit Description . . . . .	12	Compressor Crankcase Heaters . . . . .	24
Indoor Fan Failure Input . . . . .	12	Main Unit Display and ReliaTel Controls . . . . .	25
Low Pressure Control ReliaTel Control . . . . .	12	Field-Installed Control Wiring . . . . .	25
Refrigerant Circuits . . . . .	12	Control Power Transformer . . . . .	25
High Pressure Control ReliaTel Control . . . . .	12	Controls Using 24 Vac . . . . .	25
Space Temperature / RH Sensor (Optional) . . . . .	12	Controls Using DC Analog Input/Output (Standard Low Voltage Multiconductor Wire) . . . . .	26
High Temperature Sensor . . . . .	12	DC Conductors . . . . .	26
Outdoor Air Temperature and Relative Humidity Sensor . . . . .	13	System Configuration and Pre-Start . . . . .	28
Control Input (Occupied / Unoccupied) . . . . .	13	Pre-Start Up . . . . .	38
Hot Gas Reheat . . . . .	13	Start-up . . . . .	38
100 Percent Outdoor Air Hood with Damper and Filters . . . . .	13	Cooling Start-up . . . . .	38
Through the Base Electrical with Disconnect Switch . . . . .	13	Start-Up . . . . .	40
Hinged Access Doors . . . . .	13	Direct Heating Start-up . . . . .	40
Unit Inspection . . . . .	13	Direct Gas-Fired Heating Start-Up Procedure . . . . .	41
First Aid Measures . . . . .	13	Initiate . . . . .	43
Storage . . . . .	14	Standby . . . . .	44
Unit Clearances . . . . .	14	Normal Start-up Pre-purge . . . . .	44
Unit Clearances, Curb Dimensions, and Dimensional Data . . . . .	15	Ignition Trials . . . . .	44
Direct-Fired OAB Units . . . . .	15	Run . . . . .	44
Direct-Fired OAG Units . . . . .	16	Settings and Adjustments . . . . .	45
Unit Weight and Rigging . . . . .	17	Operation of the Direct Spark Ignition Control Gas Valve . . . . .	45
Unit Weight . . . . .	17	Maintenance . . . . .	47
Rigging . . . . .	18	Monthly Maintenance . . . . .	47
Installation . . . . .	19	Filters . . . . .	47
Ductwork . . . . .	19	Supply/Return Air Smoke Detector Maintenance . . . . .	47
Units with Indirect Fired Gas Heat . . . . .	19	Cooling Season . . . . .	47
General Unit Requirements . . . . .	20	Heating Season . . . . .	47
Main Electrical Power Requirements . . . . .	20	Condenser Coil Cleaning . . . . .	47
		Direct-Fired Unit Maintenance Schedule . . . . .	48

Lubrication Requirements . . . . .	50	pass . . . . .	71
Pillow Block Bearings . . . . .	50	Space Control or Single Zone VAV and OA Setpoints . . . . .	71
Frequency of Lubrication . . . . .	51	Discharge Air Temp. Reset for Single Zone VAV 72	
Dampers . . . . .	51	Supply Fan Tracking for Exhaust Fan (Field Enabled) . . . . .	72
Air Filters . . . . .	51	Hot Water Reheat . . . . .	72
Belt Tensions and Adjustments . . . . .	51	Expanded Fallback Control . . . . .	72
Suggested Belt Tension Method . . . . .	51	Sequence of Operation . . . . .	73
Gaskets . . . . .	52	General . . . . .	73
Annual Maintenance . . . . .	52	Program-Controlled Setpoints . . . . .	73
Heater Maintenance . . . . .	52	Space Control and Single Zone VAV Control	73
Inspection and Maintenance of Gas Ports . . . . .	53	Discharge Air Control and Multi-Zone VAV Control . . . . .	73
Final Process . . . . .	54	Occupied Control . . . . .	73
Performance Data . . . . .	55	Starting Sequence . . . . .	73
Superheat and Refrigeration Circuit Data . . . . .	59	Supply Fan Sequence . . . . .	73
Alarms and Troubleshooting . . . . .	61	Economizer Mode . . . . .	74
Microprocessor Control . . . . .	61	Ventilation Mode . . . . .	74
System Alarms . . . . .	61	Discharge Air Control . . . . .	74
Sensor Failure Alarm Display . . . . .	61	Multi-Zone VAV Control . . . . .	74
RTRM Failure Modes . . . . .	65	Space Control . . . . .	74
Airflow Troubleshooting . . . . .	65	Single Zone VAV Control . . . . .	74
Direct-Fired OAB and OAG Unit Flame Relays £ 400 MBh . . . . .	66	Primary Heating Mode . . . . .	74
Direct-Fired OAG Unit Flame Relays > 400 MBh 67		Discharge Air Control . . . . .	74
Attention Startup or Service Technician . . . . .	71	Multi-Zone VAV Control . . . . .	74
Horizon UC600 v11.0 Released . . . . .	71	Space Control or Single Zone VAV Control, with Energy Recovery Wheel or has Mixed Air . . . . .	74
Documents Included in This Packet . . . . .	71	Space Control or Single Zone VAV Control with No Energy Recovery Wheel and 100% Outdoor Air . . . . .	75
Unchanged from Previous Versions: . . . . .	71	Gas Heat Ignition Failure . . . . .	75
Summary of Improvements . . . . .	71	Heat Pump Heating Mode . . . . .	75
Suction Pressure Monitoring . . . . .	71	Water Source Heat Pump . . . . .	75
Compressor Run Status and Diagnostics . . . . .	71	Air Source Heat Pump – Demand Defrost Control . . . . .	75
Updated Point Names to Match Tracer SC . . . . .	71	Cooling Mode . . . . .	75
Evaporator Leaving Temperature Setpoint Reset . . . . .	71	Discharge Air Control . . . . .	75
Minimum Supply Airflow Setpoints . . . . .	71	Multi-Zone VAV Control . . . . .	75
Gas Heater Staging Off at Minimum Capacity 71		Space Control or Single Zone VAV Control, with Energy Recovery Wheel or has Mixed Air . . . . .	76
Reduced Hot Gas Reheat Purge Mode . . . . .	71		
Unit Shutdown Due to Condensate Overflow 71			
Liquid Line Pressure Setpoint Reset . . . . .	71		
Modulating ERV Exhaust and Outdoor Air By-			



## Table of Contents

---

Space Control or Single Zone VAV Control with No Energy Recovery Wheel and 100% Outdoor Air . . . . .	76	Unoccupied Cooling Mode . . . . .	78
Compressor Low Ambient Lockout . . . . .	76	Diagnostics . . . . .	78
Evaporator Frost Protection . . . . .	76	Sensor Source Failures . . . . .	79
Dehumidification Mode . . . . .	76	Economizer Fault Detection and Diagnostics	80
Discharge Air Control . . . . .	76	Start-Up Form . . . . .	81
Multi-Zone VAV Control . . . . .	76	Trane® Horizon™ DOAS . . . . .	81
Space Control with Energy Recovery Wheel or has Mixed Air . . . . .	76	Pre-Startup Checklist . . . . .	81
Space Control with No Energy Recovery Wheel and 100% Outdoor Air . . . . .	76	Voltages . . . . .	82
Hot Gas Reheat Purge . . . . .	76	Motor Data . . . . .	83
Supplemental Electric Reheat (Not Included in Standard Operation) . . . . .	76	Compressor Data . . . . .	83
Supplemental Hot Water Reheat . . . . .	77	Actuators . . . . .	83
Hot Water Reheat (No Hot Gas Reheat Installed) 77		Refrigeration Start-up . . . . .	84
Exhaust Fan Operation . . . . .	77	Test Procedures . . . . .	84
With Isolation Exhaust Fan Damper(s) . . . . .	77	Indirect Fired Gas Heat Start-up . . . . .	85
Without Isolation Exhaust Fan Dampers . . . . .	77	Furnace Data . . . . .	85
With Modulating OA/RA Dampers . . . . .	77	Gas Pressure Settings . . . . .	85
ECM Exhaust with 2-Position OA Damper . . . . .	77	Electric Heat Start-up . . . . .	85
VFD Exhaust with 2-Position OA Damper . . . . .	77	Heater Data . . . . .	85
Energy Recovery Wheel Operation (ERV) . . . . .	77	Programming and Commissioning . . . . .	86
Energy Wheel Without VFD . . . . .	77	Program Control Type (MV-13) . . . . .	86
Energy Wheel With VFD . . . . .	77	Description . . . . .	86
Additional Features . . . . .	77	Commissioning . . . . .	86
Electric Pre-Heat . . . . .	77	Typical Setpoints . . . . .	87
Space Thumbwheel Input . . . . .	77	Final Notes . . . . .	88
Split Exhaust and Return Air Path . . . . .	77		
Outdoor Airflow Monitoring . . . . .	77		
Optional Field Enabled Features . . . . .	78		
Demand Control CO2 Ventilation . . . . .	78		
Exhaust Fan Tracking . . . . .	78		
Static Pressure Control for Exhaust Fan . . . . .	78		
Unoccupied Operation . . . . .	78		
Starting Sequence . . . . .	78		
With Return Air Damper Installed . . . . .	78		
No Return Air Damper Installed . . . . .	78		
Unoccupied Heating Mode . . . . .	78		
Unoccupied Dehumid Mode . . . . .	78		



# Model Number Descriptions

## Horizon Outdoor Air Unit

### Digit 1, 2 — Unit Type

OA = Outdoor Air

### Digit 3 — Cabinet Size

B = 500 cfm–3,000 cfm  
G = 1,250 cfm–7,500 cfm

### Digit 4 — Major Design Sequence

D = Revision 1  
E = Heat Pump

### Digit 5, 6, 7 — Normal Gross Cooling Capacity (MBh)

000 = No Cooling  
036 = 3 Tons High Efficiency  
048 = 4 Tons High Efficiency  
060 = 5 Tons High Efficiency  
072 = 6 Tons High Efficiency  
084 = 7 Tons High Efficiency  
096 = 8 Tons High Efficiency  
108 = 9 Tons High Efficiency  
120 = 10 Tons High Efficiency  
144 = 12 Tons High Efficiency  
180 = 15 Tons High Efficiency  
210 = 17 Tons High Efficiency  
240 = 20 Tons High Efficiency  
264 = 22 Tons High Efficiency  
300 = 25 Tons High Efficiency  
360 = 30 Tons High Efficiency

### Digit 8 — Minor Design Sequence

A = Vertical Discharge/Vertical Return  
B = Vertical Discharge/  
Horizontal Return  
C = Horizontal Discharge/  
Vertical Return  
D = Horizontal Discharge/  
Horizontal Return

### Digit 9 — Voltage Selection

1 = 115/60/1  
2 = 208-230/60/1  
3 = 208-230/60/3  
4 = 460/60/3  
5 = 575/60/3

### Digit 10 — Reserved for Future Use

### Digit 11 — Evaporator Type

0 = No Cooling  
A = DX 3-Row  
B = DX 4-Row  
C = DX 4-Row Interlaced  
D = DX 6-Row Interlaced  
E = DX 8-Row  
F = Glycol/Chilled Water Coil  
G = DX 4-Row with  
MSP® Technology

### Digit 12 — Hot Gas Reheat

0 = No HGRH  
1 = Fin and Tube Modulating  
2 = Fin and Tube On/Off  
3 = Microchannel Modulating  
4 = Microchannel On/Off

### Digit 13 — Compressor

0 = No Compressors  
A = Scroll Compressors  
B = Digital Scroll (1<sup>st</sup> Circuit Only)  
C = Digital Scroll (1<sup>st</sup> and 2<sup>nd</sup> Circuit)  
D = Variable Speed Scroll (1<sup>st</sup> Circuit Only)  
E = Variable Speed Scroll (1<sup>st</sup> and 2<sup>nd</sup> Circuit)

### Digit 14 — Condenser

0 = No Condenser  
1 = Air-Cooled Fin and Tube  
2 = Air-Cooled Fin and Tube  
w/Head Pressure On/Off Control  
3 = Water-Cooled DX Condenser  
Copper/Steel  
4 = Air-Cooled Fin and Tube  
w/Head Pressure Variable Speed  
5 = Air-Cooled Microchannel  
6 = Air-Cooled Microchannel  
w/Head Pressure On/Off Control  
7 = Air-Cooled Microchannel  
Variable Speed  
8 = Water-Cooled DX Condenser  
Copper/Nickel

### Digit 15 — Refrigerant Capacity Control

0 = No RCC Valve  
A = RCC Valve on 1<sup>st</sup> Circuit  
B = RCC Valve on 1<sup>st</sup> and 2<sup>nd</sup> Circuit  
C = ERCC Valve on 1<sup>st</sup> Circuit  
D = ERCC Valve on 1<sup>st</sup> and 2<sup>nd</sup> Circuit  
E = HGBP Valve on 1<sup>st</sup> Circuit  
F = HGBP Valve on 1<sup>st</sup> and 2<sup>nd</sup> Circuit

### Digit 16 — Indoor Fan Motor (IFM)

0 = ECM w/Backward Curved  
Plenum Fan  
1 = Direct Drive w/ VFD  
2 = Belt Drive  
3 = Belt Drive w/VFD  
4 = Special Motor Option

### Digit 17 — Indoor Fan Wheel

A = 355  
B = 450  
C = 450 X 2  
D = 12/9 T2 (Single Fan—Belt Drive)  
E = 12/9 BT (Dual Fan—Belt Drive)

### Digit 18 — Indoor Fan Motor Power (hp)

	ECM	Belt Drive
A	1 kW	2 hp
B	2 kW	3 hp
C	3 kW	5 hp
D	4 kW	7.5 hp
E		10 hp
F		15 hp

### Digit 19 — Reserved for Future Use

### Digit 20 — Heat Type (PRI/SEC)

0 = No Heat  
A = Indirect-Fired (IF)  
B = No Primary Heat, Direct-Fired  
(DF) Secondary  
C = Electric—Stage  
D = Electric—SCR Modulating  
E = Dual Fuel (PRI-IF/SEC-DF)  
F = Dual Fuel (PRI-ELEC/SEC-DF)  
G = Dual Fuel (PRI-IF/SEC-ELEC)  
H = Dual Fuel  
(PRI-ELEC-SCR/SEC-ELEC)  
J = Hot Water  
K = Steam  
L = No Primary Heat,  
Secondary ELEC  
M = Dual Fuel  
(PRI-ELEC-STAGED/SEC-DF)  
N = Dual Fuel  
(PRI-ELEC-STAGED/SEC-ELEC)

### Digit 21 — Primary Fuel Type

0 = No Heat  
1 = Natural Gas  
2 = Propane  
3 = Electric—Open Coil  
4 = Electric—Sheathed Coil  
5 = Hot Water  
6 = Steam

### Digit 22 — Heat Capacity (Primary Heat Source)

	IF	ELEC
0	No Heat	No Heat
A	50 MBh	5 kW
B	75 MBh	10 kW
C	100 MBh	15 kW
D	125 MBh	20 kW
E	150 MBh	24 kW
F	200 MBh	28 kW
G	250 MBh	32 kW
H	300 MBh	40 kW
J	350 MBh	48 kW
K	400 MBh	60 kW
L	500 MBh	68 kW
M	600 MBh	79 kW
N		99 kW
O		111 kW
P		119 kW
X	Special Heater Option	



## Model Number Descriptions

### Digit 23 — Heat Capacity (Secondary Heat Source)

	<u>ELEC</u>	<u>DF</u>
0	= No Heat/No Secondary Heat	
A	= 5 kW	6-in. Burner— Up to 300 MBh
B	= 10 kW	12-in. Burner— Up to 400 MBh
C	= 15 kW	12-in. Burner— Up to 600 MBh
D	= 20 kW	18-in. Burner— Up to 400 MBh
E	= 24 kW	18-in. Burner— Up to 900 MBh
F	= 28 kW	

### Digit 24 — Corrosive Environment Package

0	= No Corrosive Package
1	= S/S Interior, S/S Evap Coil Casing
2	= S/S Interior, Eco Coated Coils
3	= S/S Interior, Copper/Copper Evap Coil
4	= S/S Coil Casing
5	= S/S Interior
6	= Eco-Coated Coils
7	= S/S Coil Casing with Eco-Coated Coils
8	= Copper/Copper Evap, HGRH Coils

### Digit 25, 26 — Unit Controls

00	= Non-DDC—Electromechanical
AA	= Trane—Discharge Air Control w/LON Read-Write w/Display
AB	= Trane—Space Control w/LON Read-Write w/Display
AC	= Trane—Discharge Air Control w/BACnet® (No Display)
AD	= Trane—Space Control w/BACnet (No Display)
AF	= Trane—Discharge Air Control w/BACnet w/Display
AG	= Trane—Space Control w/BACnet w/Display
AI	= Trane—Discharge Air Control w/LON Read-Write (No Display)
AJ	= Trane—Space Control w/LON Read-Write (No Display)
AK	= Trane—Multi-Zone VAV Control w/LON Read-Write w/Display
AL	= Trane—Multi-Zone VAV Control w/BACnet w/Display
AM	= Trane—Multi-Zone VAV Control w/LON Read-Write (No Display)
AN	= Trane—Multi-Zone VAV Control w/BACnet (No Display)
AO	= Trane—Single-Zone VAV Control w/LON Read-Write w/Display
AP	= Trane—Single-Zone VAV Control w/BACnet w/Display
AQ	= Trane—Single-Zone VAV Control w/LON Read-Write (No Display)
AR	= Trane—Single-Zone VAV Control w/BACnet (No Display)
XX	= Control Special

### Digit 27 — Powered Exhaust Fan Motor (PFM) and Exhaust Dampers

0	= No Powered Exhaust
1	= Direct Drive w/VFD
2	= Direct Drive (VFD by Others)
3	= Belt Drive
4	= Belt Drive w/VFD
5	= Special Motor Option
6	= ECM w/Backward Curved Plenum Fan
7	= ECM w/Backward Curved Plenum Fan and Barometric Relief Damper
8	= ECM w/Backward Curved Plenum Fan and Isolation Dampers w/End Switch
9	= Barometric Relief Dampers (NO PFM)

### Digit 28 — Powered Exhaust Fan Wheel

0	= No Powered Exhaust
A	= 355
B	= 450
C	= 450 X 2
D	= 12/9 T2 (Single Fan—Belt Drive)
E	= 12/9 BT (Dual Fan—Belt Drive)

### Digit 29 — Powered Exhaust Fan Motor Power

	<u>ECM</u>	<u>Belt Drive</u>
0	= No Powered Exhaust	
A	= 1 kW	2 hp
B	= 2 kW	3 hp
C	= 3 kW	5 hp
D	= 4 kW	7.5 hp
E	=	10 hp
F	=	15 hp

### Digit 30 — Reserved for Future Use

### Digit 31 — ERV (Requires Powered Exhaust)

0	= No ERV
A	= ERV—Composite Construction w/Bypass
B	= ERV—Composite Construction with Frost Protection w/VFD
C	= ERV—Aluminum Construction w/Bypass
D	= ERV—Aluminum Construction with Frost Protection w/VFD

### Digit 32 — ERV Size

0	= No ERV
1	= 3014
2	= 3622
3	= 4136
4	= 4634
5	= 5856

### Digit 33 — Damper Options

0	= 100% OA 2-Position Damper
1	= 100% OA 2-Position Damper w/RA 2-Position Damper
2	= Modulating OA and RA Dampers w/Economizer

### Digit 34 — Filtration Options

A	= No Filters
B	= MERV-8, 30%
C	= MERV-13, 80%
D	= MERV-14, 95%
E	= MERV-8 30%, MERV-13 80%
F	= MERV-8 30%, MERV-14 95%
G	= MERV-8, 30% with UVC
H	= MERV-13, 80% with UVC
J	= MERV-14, 95% with UVC
K	= MERV-8 30%, MERV-13 80%, and UVC
L	= MERV-8 30%, MERV-14 95%, and UVC
M	= MERV-8 30% and TCACS
N	= MERV-13 80% and TCACS
P	= MERV-14 95% and TCACS
Q	= MERV-8 30%, MERV-13 80%, and TCACS
R	= MERV-8 30%, MERV-14 95%, and TCACS
X	= Special Filter Options

### Digit 35 — Smoke Detector (Factory-Installed)

0	= No Smoke Detector
1	= Supply Smoke Detector
2	= Return Smoke Detector
3	= Supply and Return Smoke Detectors

### Digit 36 — Electrical Options

0	= Terminal Block
A	= Non-Fused Disconnect Switch
B	= Fused Disconnect Switch
C	= Non-Fused Disconnect Switch w/Convenience Outlet
D	= Fused Disconnect Switch w/Convenience Outlet
E	= Dual Point Power
F	= Dual Point Power w/Convenience Outlet
G	= 65 SCCR Electrical Rating w/Non-Fused Disconnect
H	= 65 SCCR Electrical Rating w/Fused Disconnect
J	= 65 KAIC Electrical Rating w/Non-Fused Disconnect
K	= 65 KAIC Electrical Rating w/Fused Disconnect
L	= 65 KAIC Non-Fused w/Convenience Outlet
M	= 65 KAIC Fused w/Convenience Outlet
N	= 65 SCCR Non-Fused w/Convenience Outlet



**Digit 37 — Airflow Monitoring**

- 0 = No Airflow Monitoring
- 1 = Airflow Monitoring—IFM  
Piezo Ring
- 2 = Airflow Monitoring—PE  
Piezo Ring
- 3 = Airflow Monitoring—Outdoor Air  
with Display and IFM  
w/Piezo Ring
- 4 = Airflow Monitoring—IFM  
Piezo Ring and PE Piezo Ring
- 5 = Airflow Monitoring—Outdoor Air  
Monitoring w/Display Supply Air  
and Exhaust Air w/Piezo Rings
- 6 = Airflow Monitoring—Outdoor Air  
Monitoring for Direct-Fired  
Heat Units

**Digit 38 — Accessories**

- 0 = No Options
- A = Hailguards
- B = Hailguards and LED Service  
Light in Supply Fan Section
- C = LED Service Light in Supply  
Fan Section
- D = Hailguards and LED Service  
Light in  
Exhaust Fan Section
- E = Hailguards and LED Service  
Light in Supply  
and Exhaust  
Fan Section
- F = LED Service Light in Exhaust  
Fan Section
- G = LED Service Light in Supply and  
Exhaust Fan Section

**Digit 39 — Altitude**

- 0 = Sea Level to 1,000 Feet
- 1 = 1,001 to 2,000 Feet
- 2 = 2,001 to 3,000 Feet
- 3 = 3,001 to 4,000 Feet
- 4 = 4,001 to 5,000 Feet
- 5 = 5,001 to 6,000 Feet
- 6 = 6,001 to 7,000 Feet
- 7 = Above 7,000 Feet



# General Information

## Overview of Manual

**Note:** One copy of this document ships inside the control panel of each unit and is customer property. It must be retained by the unit's maintenance personnel.

This booklet describes proper installation, operation, and maintenance procedures for air cooled systems. By carefully reviewing the information within this manual and following the instructions, the risk of improper operation and/or component damage will be minimized.

It is important that periodic maintenance be performed to help assure trouble free operation. A maintenance schedule is provided at the end of this manual. Should equipment failure occur, contact a qualified service organization with qualified, experienced HVAC technicians to properly diagnose and repair this equipment.

## Model Number Description

All products are identified by a multiple-character model number that precisely identifies a particular type of unit. An explanation of the alphanumeric identification code is provided (see the Model Number chapter). Its use will enable the owner/operator, installing contractors, and service engineers to define the operation, specific components, and other options for any specific unit.

When ordering replacement parts or requesting service, be sure to refer to the specific model number and serial number printed on the unit nameplate.

## Unit Nameplate

A Mylar® unit nameplate is located on the unit's corner support next to the control box. It includes the unit model number, serial number, electrical characteristics, refrigerant charge, as well as other pertinent unit data.

## Compressor Nameplate

The nameplate for the compressors are located on the side of the compressor.

## Unit Description

Before shipment, each unit is leak tested, dehydrated, charged with refrigerant and compressor oil, and run tested for proper control operation.

The condenser coils are aluminum fin, mechanically bonded to copper tubing.

Direct-drive, vertical discharge condenser fans are provided with built-in thermal overload protection.

The Outdoor Air Unit Main Unit Display and ReliaTel™ Control Module (RTRM) are microelectronic control systems. The acronym RTRM is extensively throughout this document when referring to the control system network.

The optional Main Unit Display and the RTRM are mounted in the Main Control Panel. The Main Unit Display and RTRM receive information from sensors and customer binary

contacts to satisfy the applicable request for ventilation, cooling, dehumidification and heating.

## Indoor Fan Failure Input

The Indoor Fan Failure Switch (IFFS) is connected to verify indoor fan operation.

When there is a call for the indoor fan to be energized, the differential pressure switch, connected to the Main Unit Display, must prove airflow within 60 seconds or the Main Unit Display will shut off all mechanical operations, lock the system out and send a diagnostic alarm to the Unit Display. The system will remain locked out until a reset is initiated through the MCM via the Alarm Reset Function on the Unit Display.

## Low Pressure Control ReliaTel Control

This input incorporates the compressor low pressure control (CLP 1/2) of each refrigeration circuit and can be activated by opening a field supplied contact installed on the OAUTS.

If this circuit is open before the compressor is started, the ReliaTel™ control will not allow the affected compressor to operate. Anytime this circuit is opened for 1 continuous second during compressor operation, the compressor is immediately turned "Off." The compressor will not be allowed to restart for a minimum of 3 minutes should the contacts close.

If four consecutive open conditions occur during the first three minutes of operation, the compressor will be locked out, and a manual reset will be required to restart the compressor.

## Refrigerant Circuits

Units shall incorporate a 4- or 6-row evaporator coil. All circuits shall have thermal expansion valves (TXVs), service pressure ports, sight glass, and refrigerant line filter drier as standard. An area will be provided for replacement suction line driers. Each refrigerant circuit is equipped with a factory installed and preset refrigerant capacity control (RCC) to prevent evaporator coil temperatures below approximately 38°F (114 lb suction). The refrigerant capacity device is not installed when the unit is equipped with a digital scroll.

## High Pressure Control ReliaTel Control

The compressor high pressure controls (CHP 1/2) are wired in series between the compressor outputs on RTRM1 (CHP 1/2) and the compressor contactor coils. If one of the high pressure control switches opens, the RTRM senses a lack of current while calling for cooling and locks the compressor out.

## Space Temperature / RH Sensor (Optional)

Field installed, wall mounted temperature sensor (BAYSENS036A) and humidity to control space cooling, heating and dew point.

## High Temperature Sensor

The Discharge Air Temperature Sensor (DTC) supplies a continuous signal to the MCM. If the MCM does not sense a

signal from the DTC, the unit will go into LOCKOUT and require a manual restart once the proper operation of the DTC has been confirmed. If DAT exceeds Discharge Air High Temperature Cutoff (DHCS) of 125°F for 10 minutes, the unit will shut down and require manual restart.

## Outdoor Air Temperature and Relative Humidity Sensor

This factory installed combination outdoor air sensor located in the outdoor air hood is designed to sense both outdoor air temperature and relative humidity for use by the microprocessor controller to make required ventilation, cooling, dehumidification and heating decisions.

## Control Input (Occupied / Unoccupied)

Terminals are provided on the terminal strip labeled OAUTS for a field installed dry contact or switch closure to put the unit in the Occupied or Unoccupied modes.

## Hot Gas Reheat

This option shall consist of a hot-gas reheat coil located on the leaving air side of the evaporator.

## 100 Percent Outdoor Air Hood with Damper and Filters

Factory-installed and -integrated 100 percent outdoor air hood with damper controlled by a direct coupled actuator.

## Through the Base Electrical with Disconnect Switch

Factory installed 3-pole, molded case disconnect switch with provisions for through the base electrical connections will be included. The disconnect switch, with integral overcurrent circuit breaker, will be installed in the unit in a water tight enclosure with access through a hinged door. Factory wiring will be provided from the switch to the unit high voltage terminal block. The switch will be UL/CSA agency recognized.

## Hinged Access Doors

Hinged access doors with hold open brackets will be factory-installed.

## Unit Inspection

### WARNING

#### Fiberglass Wool!

Product may contain fiberglass wool. Disturbing the insulation in this product during installation, maintenance or repair will expose you to airborne particles of glass wool fibers and ceramic fibers known to the state of California to cause cancer through inhalation. Glass wool fibers may also cause respiratory, skin or eye irritation.

### AVERTISSEMENT

#### Laine de verre!

Le produit peut contenir de la laine de verre. Des interventions inappropriées sur l'isolation de ce produit pendant les opérations d'installation, d'entretien ou de réparation vous exposent à des particules aériennes de fibres de verre ou de fibres céramiques, responsables selon la législation américaine (état de Californie) de risques de cancers par inhalation. Les fibres de verre peuvent aussi provoquer des phénomènes d'irritation au niveau du système respiratoire, de la peau ou des yeux.

As soon as the unit arrives at the job site:

- Verify that the nameplate data matches the data on the sales order and bill of lading (including electrical data).
- Verify that the power supply complies with the unit nameplate specifications.
- Visually inspect the exterior of the unit, including the roof, for signs of shipping damage.
- Visually inspect the internal components for shipping damage as soon as possible after delivery and before it is stored. Do *not* walk on the sheet metal base pans.
- If concealed damage is discovered, notify the carrier's terminal of damage immediately by phone and by mail. Concealed damage must be reported within 15 days.  
Request an immediate joint inspection of the damage by the carrier and the consignee. Do not remove damaged material from the receiving location. Take photos of the damage, if possible. The owner must provide reasonable evidence that the damage did not occur after delivery.
- Notify the appropriate sales representative before installing or repairing a damaged unit.

- Avoid breathing fiberglass dust.
- Use a NIOSH approved dust/mist respirator.
- Avoid contact with the skin or eyes. Wear long-sleeved, loose-fitting clothing, gloves, and eye protection.
- Wash clothes separately from other clothing: rinse washer thoroughly.
- Operations such as sawing, blowing, tear-out, and spraying may generate fiber concentrations requiring additional respiratory protection. Use the appropriate NIOSH approved respiration in these situations.

## First Aid Measures

### Eye Contact

Flush eyes with water to remove dust. If symptoms persist, seek medical attention.

### Skin Contact

Wash affected areas gently with soap and warm water after handling.



## General Information

---

### Storage

Take precautions to prevent condensate from forming inside the unit's electrical compartments and motors if:

- the unit is stored before it is installed; or,
- the unit is set on the roof curb, and temporary heat is provided in the building. Isolate all side panel service entrances and base pan openings (e.g., conduit holes, S/A and R/A openings, and flue openings) from the ambient air until the unit is ready for startup.

**Note:** *Do not use the unit's heater for temporary heat without first completing the startup procedure detailed in "Start-Up," p. 40.*

The manufacturer will not assume any responsibility for equipment damage resulting from condensate accumulation on the unit's electrical and/or mechanical components.

### Unit Clearances

Unit Clearances, Curb Dimensions, and Dimensional Data chapter contains figures that illustrate the minimum operating and service clearances for either a single or multiple unit installation. These clearances are the minimum distances necessary to assure adequate serviceability, cataloged unit capacity, and peak operating efficiency.

Providing less than the recommended clearances may result in condenser coil starvation, "short-circuiting" of exhaust or recirculation of hot condenser air.



# Unit Clearances, Curb Dimensions, and Dimensional Data

**⚠ WARNING**

**Combustible Materials!**

Failure to maintain proper clearance between the unit heat exchanger, vent surfaces and combustible materials could cause a fire which could result in death or serious injury or property damage. Refer to unit nameplate and installation instructions for proper clearances.

**⚠ AVERTISSEMENT**

**Matériaux combustibles!**

Tout manquement à l'obligation de maintenir une distance appropriée entre l'échangeur de chaleur de l'unité, les surfaces de ventilation et les matériaux combustibles peut provoquer un incendie pouvant résulter en des blessures corporelles graves, voire mortelles, ou des dommages matériels. Reportez-vous à la plaque signalétique de l'unité et aux instructions d'installation pour connaître les distances appropriées.

## Direct-Fired OAB Units

### Unit Clearances

Figure 1. Typical installation clearances for direct-fired OAB unit (in.)

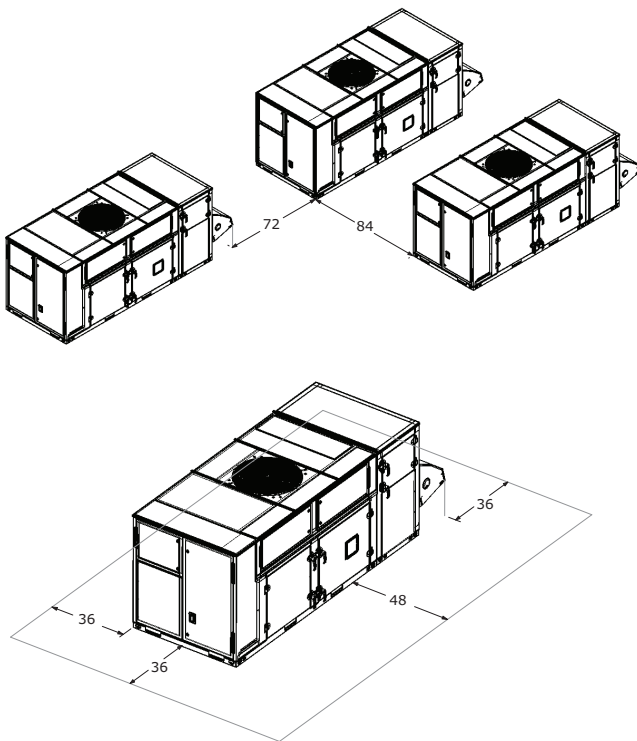

### Curb Dimensions

Figure 2. Unit curb data for direct-fired OAB tons (in.)

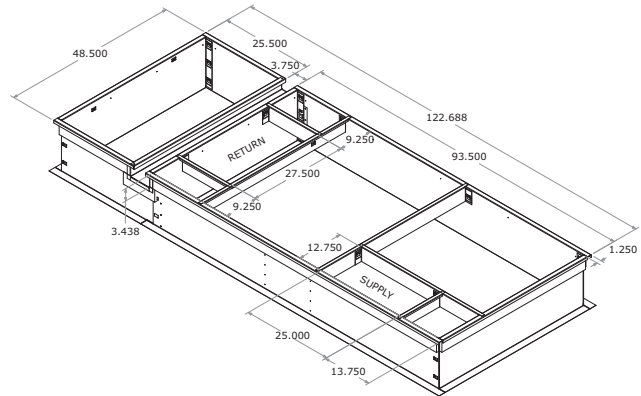

### Dimensional Data

Figure 3. Unit dimensional data for direct-fired OAB (in.)

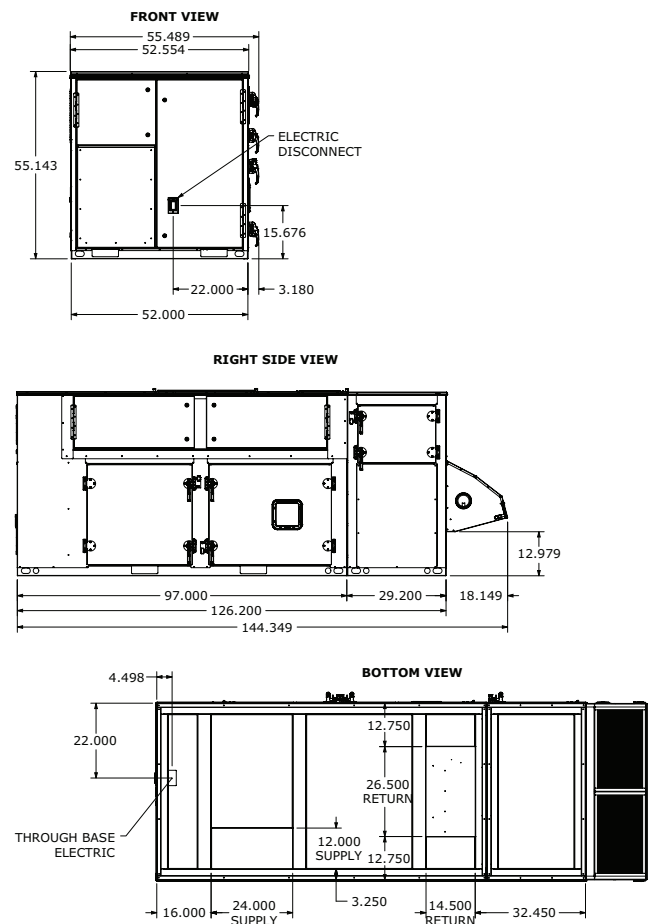



# Unit Clearances, Curb Dimensions, and Dimensional Data

## Direct-Fired OAG Units

### Unit Clearances

Figure 4. Typical installation clearances for direct-fired OAG unit (in.)

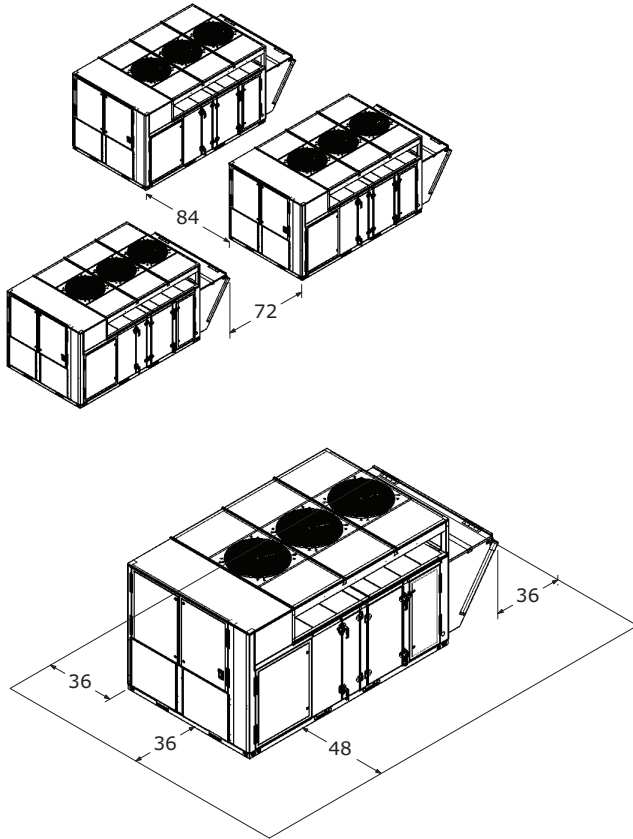

### Dimensional Data

Figure 6. Unit dimensional data for direct-fired OAG (in.)

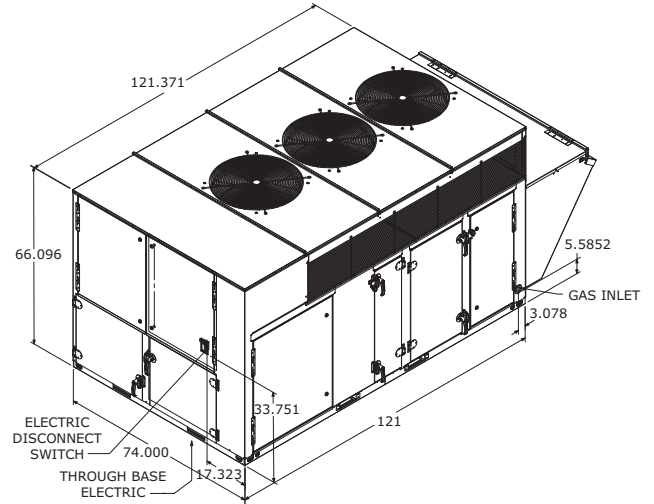

### Curb Dimensions

Figure 5. Unit curb data for direct-fired OAG tons (in.)

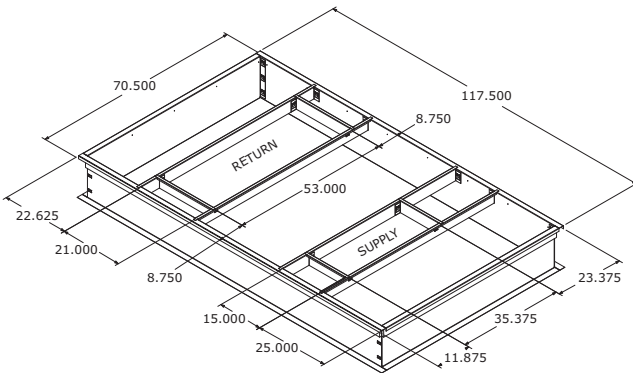





# Unit Weight and Rigging

## ⚠ WARNING

### Heavy Objects!

Failure to follow instructions below or properly lift unit could result in unit dropping and possibly crushing operator/technician which could result in death or serious injury, and equipment or property-only damage. Ensure that all the lifting equipment used is properly rated for the weight of the unit being lifted. Each of the cables (chains or slings), hooks, and shackles used to lift the unit must be capable of supporting the entire weight of the unit. Lifting cables (chains or slings) may not be of the same length. Adjust as necessary for even unit lift.

## ⚠ AVERTISSEMENT

### Objets lourds!

Le non-respect des instructions ci-dessous ou un levage inapproprié de l'unité peut provoquer sa chute voire écraser l'opérateur/le technicien, ce qui peut occasionner des blessures graves voire mortelles, et éventuellement endommager l'équipement ou provoquer des dégâts matériels. Assurez-vous que l'équipement de levage utilisé est adapté au poids de l'unité à soulever. Chaque câble (chaîne ou élingue), crochet ou manille utilisé pour le levage de l'unité doit être assez robuste pour supporter le poids total de l'unité. Les câbles, chaînes ou élingues de levage ne doivent pas être de longueur identique. Procédez au réglage afin de soulever l'unité de manière équilibrée.

## ⚠ WARNING

### Improper Unit Lift!

Failure to properly lift unit could result in unit dropping and possibly crushing operator/technician which could result in death or serious injury, and equipment or property-only damage. Test lift unit approximately 24 inches to verify proper center of gravity lift point. To avoid dropping of unit, reposition lifting point if unit is not level.

## ⚠ AVERTISSEMENT

### Levage inapproprié de l'unité!

Le non-respect des instructions ci-dessous ou un levage inapproprié de l'unité peut provoquer sa chute voire écraser l'opérateur/le technicien, ce qui peut occasionner des blessures graves voire mortelles, et éventuellement endommager l'équipement ou provoquer des dégâts matériels. Faites un test de levage de l'unité d'environ 60 cm (24 po) afin de vérifier que le point de levage correspond au centre de gravité de l'appareil. Pour éviter une chute de celle-ci, ajustez son point de levage si elle n'est pas à l'horizontale.

## Unit Weight

Table 1. Typical unit weight

Model Number	Operating Weight (lb)	
	Min	Max
OABD036*	1655	1839
OABD048*	1655	1839
OABD060*	1655	1839
OABD072*	1695	1879
OABD084*	1695	1879
OABD096*	1695	1879
OABD108*	1736	1920
OAGD120*	2912	3198
OAGD144*	2912	3198
OAGD180*	2913	3199
OAGD210*	3062	3348
OAGD240*	3134	3439
OAGD264*	3135	3439
OAGD300*	3175	3489
OAGD360*	3186	3500

Note: Minimum and maximum weights vary widely due to the highly configurable nature of the product.

## Rigging

**Figure 7. Rigging**

**6-point lift**  
(Model: Direct-fired OAB)

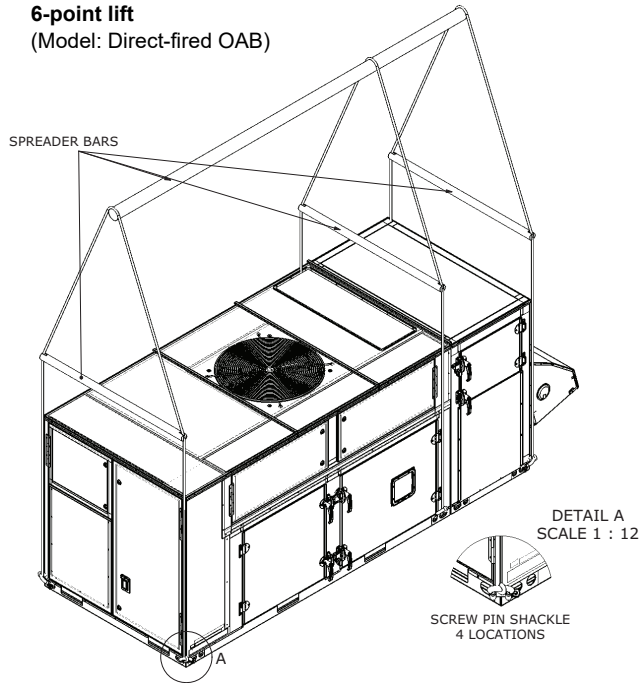

3. Test-lift the unit to ensure it is properly rigged and balanced, make any necessary rigging adjustments.
4. Lift the unit and position it into place. Remove fork pockets prior to setting on the curb.
5. Downflow units; align the base rail of the unit with the curb rail while lowering the unit onto the curb. Make sure that the gasket on the curb is not damaged while positioning the unit.

**4-point lift**  
(Model: Direct-fired OAG)

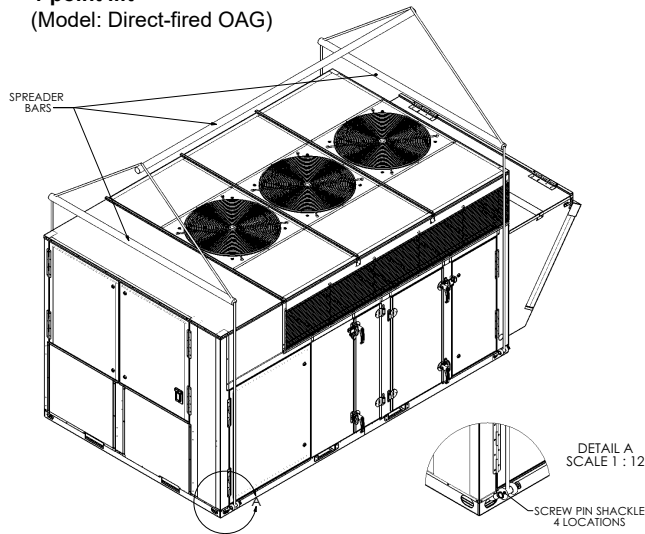

Before proceeding, refer to [Table 1, p. 17](#) for typical unit operating weights and [Figure 7, p. 18](#) for rigging drawing.

1. Rig the unit as shown in [Figure 7, p. 18](#). Attach adequate strength lifting slings to all four lifting brackets in the unit base rail. Do not use cables, chains, or slings except as shown.
2. Install a lifting bar, as shown in [Figure 7, p. 18](#), to protect the unit and to facilitate a uniform lift. The minimum distance between the lifting hook and the top of the unit should be 7 feet.

# Installation

## ⚠ WARNING

### Hazardous Service Procedures!

Failure to follow all precautions in this manual and on the tags, stickers, and labels could result in death or serious injury.

Technicians, in order to protect themselves from potential electrical, mechanical, and chemical hazards, **MUST** follow precautions in this manual and on the tags, stickers, and labels, as well as the following instructions: Unless specified otherwise, disconnect all electrical power including remote disconnect and discharge all energy storing devices such as capacitors before servicing. Follow proper lockout/tagout procedures to ensure the power can not be inadvertently energized. When necessary to work with live electrical components, have a qualified licensed electrician or other individual who has been trained in handling live electrical components perform these tasks.

## ⚠ AVERTISSEMENT

### Procédures d'entretien dangereuses!

Le non-respect de toutes les précautions contenues dans ce manuel ainsi que sur les étiquettes et les autocollants peut entraîner des blessures graves voire mortelles.

Les techniciens, afin d'être protégés des éventuels risques électriques, mécaniques et chimiques, **DOIVENT** suivre les précautions contenues dans ce manuel, sur les étiquettes et les autocollants, ainsi que les instructions suivantes : Sauf indication contraire, coupez toute l'alimentation électrique y compris les disjoncteurs à distance et déchargez tous les dispositifs de stockage d'énergie comme les condensateurs avant l'entretien. Respectez les procédures de verrouillage et d'étiquetage appropriées pour éviter tout risque de remise sous tension accidentelle. S'il est nécessaire de travailler avec des composants électriques sous tension, demandez à un électricien qualifié et agréé ou à une autre personne ayant la formation nécessaire pour manipuler des composants électriques sous tension d'exécuter ces tâches.

## Ductwork

Elbows with turning vanes or splitters are recommended to minimize air noise due to turbulence and to reduce static pressure.

When attaching the ductwork to the unit, provide a water-tight flexible connector at the unit to prevent operating sounds from transmitting through the ductwork.

All outdoor ductwork between the unit and the structure should be weather proofed after installation is completed.

**Note:** For sound consideration, cut holes in the roof deck only for the ductwork penetrations. Do not cut out the roof

deck within the entire curb perimeter. All duct work must be installed and connected to top of roof curb before the unit is set on curb.

### If a Curb Accessory Kit is not used:

1. Be sure to use flexible duct connections at the unit.
2. Gaskets must be installed around the curb perimeter flange and the supply and return air opening flanges.

**Note:** For units with electric heat in the primary heating position, refer to [Figure 8](#).

Figure 8.

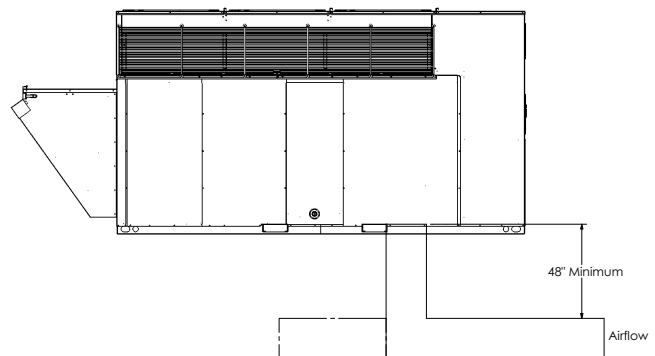

**Important:** Bottom discharge units with open coil electric heater in primary heat location require discharge duct with 90° elbow. This is a **MANDATORY** installation requirement.

**Note:** A minimum 48" of straight duct is required before an elbow. This is a requirement for both vertical and horizontal discharge regardless of heat type.

## Units with Indirect Fired Gas Heat

- Ductwork leaving unit should not have an immediate duct tee.
- If possible allow 4' vertical duct before first duct tee.
- Ensure duct work does not have an extreme transition at the outlet of the unit. Extreme transitions can cause restriction of airflow and high limit trips (See [Figure 9](#), p. 20).
- Discharge Air sensor should be placed in the center of the ductwork at least 4' from the unit or after the first 90° bend.

**Figure 9. Extreme transition in duct work**

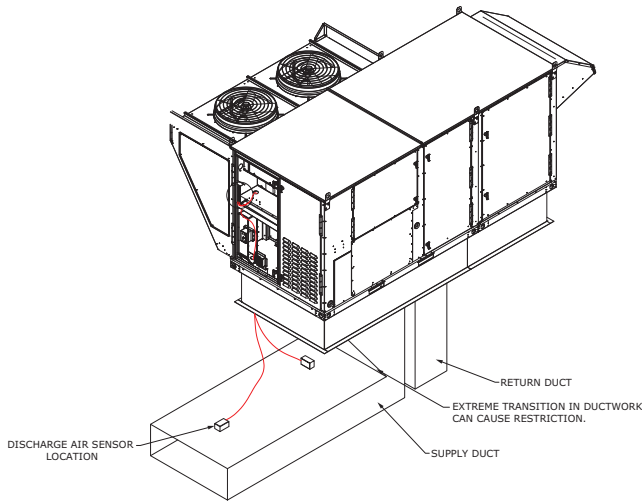

## General Unit Requirements

The checklist listed below is a summary of the steps required to successfully install a commercial unit. This checklist is intended to acquaint the installing personnel with what is required in the installation process. **It does not replace the detailed instructions called out in the applicable sections of this manual.**

- Check the unit for shipping damage and material shortage. File a freight claim and notify appropriate sales representative if damage or shortage is discovered.
- Verify that the unit nameplate model, options, and voltage are correct.
- Verify that the installation location of the unit will provide the required clearance for proper operation.
- Assemble and install the roof curb (if applicable). Refer to the latest edition of the curb installers guide that ships with each curb kit. Check curb for level installation; if not level, shim as required.
- Rigging unit (refer to “Unit Weight and Rigging,” p. 17).
- Set the unit onto the curb; check for level.
- Ensure unit-to-curb seal is tight and without buckles or cracks.
- Install and connect proper condensate drain line to the evaporator condensate pan drain connection (see Figure 10, p. 21).

## Main Electrical Power Requirements

- Verify that the power supply complies with the unit nameplate specifications.
- Inspect all control panel components; tighten any loose connections.
- Connect properly sized and protected power supply wiring to a field-supplied/-installed disconnect switch and to the main power terminal block (HTB1) in the unit control panel.
- Connect properly-sized earth ground.

**Note:** All field-installed wiring must comply with NEC and applicable local codes.

## Condensate Drain Configuration

OAU units are selected based on dehumidification capability. As such, condensate can form at a high rate. Therefore, the OAU drain pan and condensate line are sized and designed accordingly. However, an often-overlooked element of proper condensate drainage is proper P-Trap and drain line sizing and installation. An incorrectly-designed and -installed P-Trap can restrict condensate flow or cause water in the condensate drain pan to “spit” or “geyser” which may cause condensate overflow. Carefully install and trap the drain pan to ensure adequate condensate removal under all conditions.

An evaporator condensate drain connection is provided on the unit. Refer to Figure 12, p. 22 for the drain location.

A condensate trap must be installed at the unit due to the drain connection being on the “negative pressure” side of the fan. Install the P-Trap using the guidelines in Figure 10.

Pitch drain lines connected to P-Trap at least 1/2 inch for every 10 feet of horizontal run to assure proper condensate flow. Do not allow the horizontal run to sag causing a possible double-trap condition which could result in condensate backup due to “air lock”.

Figure 10. Condensate trap installation

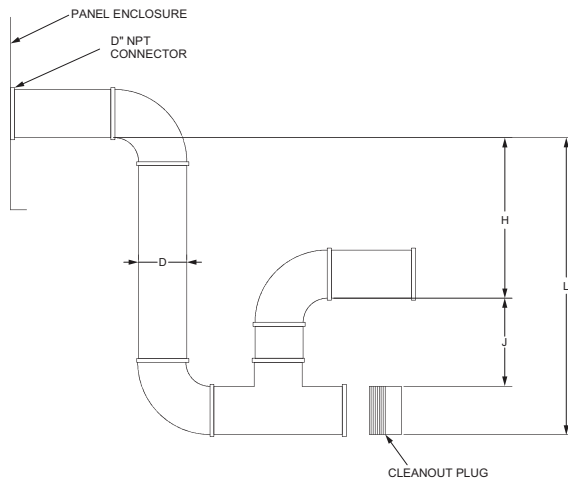

D = Pipe diameter (1 in.)  
 H = Internal static pressure (in wg) + 1 in.  
 J = H x 0.5  
 L = H + J + D

**Notes:**

1. Pitch drain at least 1/2 in. per 10 ft horizontal run.
2. Condensate drain pan will not drain properly if P-trap is not primed and of adequate height to allow for cabinet operating negative pressure.

**Filter Installation**

**⚠ WARNING**

**Do Not Install Filters or Flammable Components Downstream of Direct-Fired Burner!**

Installing filters or flammable components downstream of the direct-fired burner could cause a fire hazard and result in death or serious injury.

**⚠ AVERTISSEMENT**

**N'installez pas de filtre ou de composant inflammable en aval du brûleur à feu direct!**

L'installation de filtres ou de composants inflammables en aval du brûleur à feu direct peut provoquer un risque d'incendie et résulter en des blessures graves, voire mortelles..

Each unit ships with 2-inch permanent filters (mist eliminators) along with the specified MERV-rated pleated filters installed in the air inlet hood. The quantity of filters is determined by unit size. Access to the filters is through the hinged filter access panel on the air intake hood. Filter type, size, and quantity are determined by selected filter option and unit size.

**Note:** Do not operate the unit without filters. Pleated filters are installed in the inlet hood in the direct-fired unit.

**Field Installed Power Wiring**

**⚠ WARNING**

**Proper Field Wiring and Grounding Required!**

Failure to follow code could result in death or serious injury. All field wiring **MUST** be performed by qualified personnel. Improperly installed and grounded field wiring poses **FIRE** and **ELECTROCUTION** hazards. To avoid these hazards, you **MUST** follow requirements for field wiring installation and grounding as described in NEC and your local/state/national electrical codes.

**⚠ AVERTISSEMENT**

**Câblage sur site et mise à la terre corrects nécessaires!**

Le non-respect de la réglementation peut entraîner des blessures graves, voire mortelles. Il est **IMPÉRATIF** de confier l'ensemble du câblage sur site à un électricien qualifié. Un câblage sur site mal installé ou mal mis à la terre constitue des risques **D'INCENDIE** et **D'ÉLECTROCUTION**. Pour éviter ces risques, il est **IMPÉRATIF** de respecter les obligations en matière de pose de câblage sur site et de mise à la terre tel que stipulé dans les règles du NEC et dans les réglementations électriques locales/nationales.

An overall dimensional layout for the standard field installed wiring entrance into the unit is illustrated in Figure 11 and Figure 12. To ensure that the unit's supply power wiring is properly sized and installed, refer to the following guidelines.

Figure 11. OAB utility connections (in.)

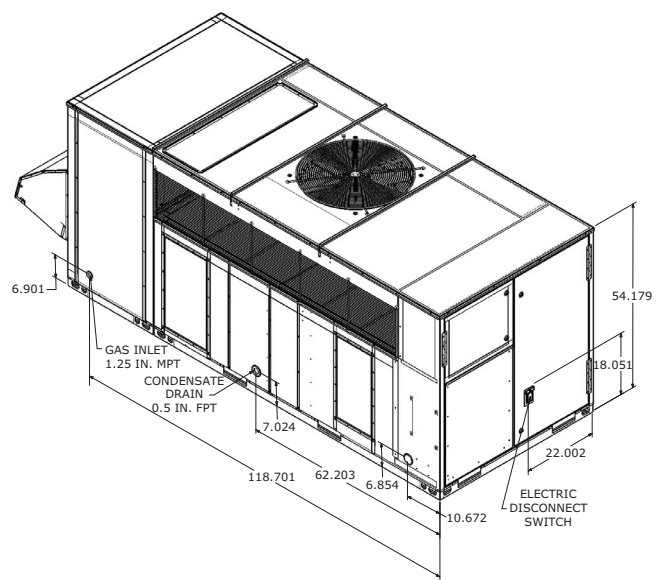



# Installation

Figure 12. OAG utility connections (in.)

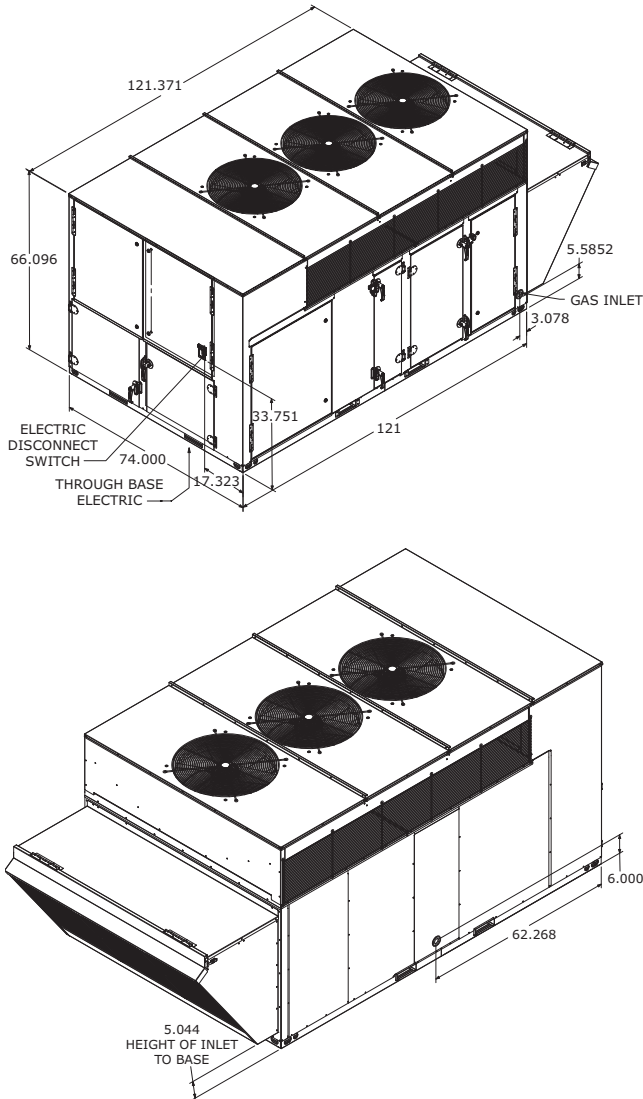

Table 2. OAB/OAG unit

Maximum MBh	Burner Size (in.)	Pipe Connection (in.)
300	6	1
660	12	1
814	18	1-1/4

**Note:** All field installed wiring must conform to NEC guidelines as well as State and Local codes.

Verify that the power supply available is compatible with the unit's nameplate ratings. The available supply power must be within 10 percent of the rated voltage stamped on the nameplate. Use only copper conductors to connect the power supply to the unit.

## Main Unit Power

### ⚠ WARNING

#### Hazardous Voltage!

Failure to disconnect power before servicing could result in death or serious injury. Disconnect all electric power, including remote disconnects before servicing. Follow proper lockout/tagout procedures to ensure the power can not be inadvertently energized.

### ⚠ AVERTISSEMENT

#### Risque d'électrocution!

Le non-respect de cette consigne peut entraîner des blessures graves, voire mortelles. Avant toute intervention, coupez l'alimentation électrique, y compris aux sectionneurs à distance. Suivez scrupuleusement les procédures de verrouillage/mise hors service préconisées pour empêcher tout rétablissement accidentel de l'alimentation électrique.

### NOTICE

#### Use Copper Conductors Only!

Failure to use copper conductors could result in equipment damage as unit terminals are not designed to accept other types of conductors.

## Standard Wiring

### ⚠ WARNING

#### Proper Field Wiring and Grounding Required!

Failure to follow code could result in death or serious injury. All field wiring **MUST** be performed by qualified personnel. Improperly installed and grounded field wiring poses **FIRE** and **ELECTROCUTION** hazards. To avoid these hazards, you **MUST** follow requirements for field wiring installation and grounding as described in NEC and your local/state electrical codes.

### ⚠ AVERTISSEMENT

#### Câblage sur site et mise à la terre corrects nécessaires!

Le non-respect de la réglementation peut entraîner des blessures graves, voire mortelles. Il est **IMPÉRATIF** de confier l'ensemble du câblage sur site à un électricien qualifié. Un câblage sur site mal installé ou mal mis à la terre constitue des risques **D'INCENDIE** et **D'ÉLECTROCUTION**. Pour éviter ces risques, il est **IMPÉRATIF** de respecter les obligations en matière de pose de câblage sur site et de mise à la terre tel que stipulé dans les règles du NEC et dans les réglementations électriques locales/nationales.



The electrical service must be protected from over current and short circuit conditions in accordance with NEC requirements. Protection devices must be sized according to the electrical data on the nameplate.

1. Location of the electrical service entrance is illustrated in [Figure 12](#). Complete the unit's power wiring connections onto either; the main terminal block HTB1 inside the unit control panel, the factory mounted non-fused disconnect switch (UCD) or circuit breaker (UCB), or the electric heat non-fused disconnect switch. Refer to the customer connection diagram that shipped with the unit for specific termination points.
2. Provide proper grounding for the unit in accordance with local and national codes.

Use the following checklist in conjunction with the checklist in "[General Unit Requirements](#)," p. 20 to ensure that the unit is properly installed and ready for operation.

- Verify that the correct size and number of filters are in place.
- Inspect the interior of the unit for tools and debris and install all panels in preparation for starting the unit.
- Check all electrical connections for tightness and "point of termination" accuracy.
- Verify condenser airflow is unobstructed.
- Verify that the condenser and indoor fans turn freely without rubbing and are properly tightened on the shafts.
- Check motor mounting bolts and inlet cone for tightness. Free spin wheel by hand to check for proper alignment of motor, wheel, and inlet cone. Record motor nameplate amps at unit-rated voltage.
- Check proper indoor fan wheel rotation. Wheel housing will be marked to indicate direction of proper rotation.
- With access doors closed and secured, operate blower at 100 percent speed. Check amp readout of amps output to indoor fan at VFD display to confirm operation within motor amp capacity.

## Voltage Imbalance

### **⚠ WARNING**

#### **Live Electrical Components!**

**Failure to follow all electrical safety precautions when exposed to live electrical components could result in death or serious injury. When necessary to work with live electrical components, have a qualified licensed electrician or other individual who has been properly trained in handling live electrical components perform these tasks.**

### **⚠ AVERTISSEMENT**

#### **Composants électriques sous tension!**

**Le non-respect de toutes les consignes de sécurité lors de la manipulation de composants électriques sous tension peut entraîner des blessures graves, voire mortelles. S'il est nécessaire de travailler avec des composants électriques sous tension, demandez à un électricien qualifié et agréé ou à une autre personne ayant la formation nécessaire pour manipuler des composants électriques sous tension d'exécuter ces tâches.**

Three phase electrical power to the unit must meet stringent requirements for the unit to operate properly. Measure each leg (phase-to-phase) of the power supply. Each reading must fall within the utilization range stamped on the unit nameplate. If any of the readings do not fall within the proper tolerances, notify the power company to correct this situation before operating the unit.

Excessive three phase voltage imbalance between phases will cause motors to overheat and eventually fail. The maximum allowable voltage imbalance is 2.0 percent. Measure and record the voltage between phases 1, 2, and 3 and calculate the amount of imbalance as follows:

$$\% \text{ Voltage Imbalance} = 100 \times \frac{AV - VD}{AV} \text{ where;}$$

$$AV \text{ (Average Voltage)} = \frac{\text{Volt 1} + \text{Volt 2} + \text{Volt 3}}{3}$$

V1, V2, V3 = Line Voltage Readings

VD = Line Voltage reading that deviates the farthest from the average voltage.

Example: If the voltage readings of the supply power measured 221, 230, and 227, the average volts would be:

$$\frac{221 + 230 + 227}{3} = 226 \text{ Avg.}$$

VD (reading farthest from average) = 221

The percentage of Imbalance equals:

$$100 \times \frac{226 - 221}{226} = 2.2\%$$

The 2.2 percent imbalance in this example exceeds the maximum allowable imbalance of 2.0 percent. This much imbalance between phases can equal as much as a 20 percent current imbalance with a resulting increase in motor winding temperatures that will decrease motor life. If the voltage imbalance is over 2.0 percent, notify the proper agencies to correct the voltage problem before operating this equipment.



## Electrical Phasing (Three-Phase Motors)

### ⚠ WARNING

#### Live Electrical Components!

Failure to follow all electrical safety precautions when exposed to live electrical components could result in death or serious injury. When necessary to work with live electrical components, have a qualified licensed electrician or other individual who has been properly trained in handling live electrical components perform these tasks.

### ⚠ AVERTISSEMENT

#### Composants électriques sous tension!

Le non-respect de toutes les consignes de sécurité lors de la manipulation de composants électriques sous tension peut entraîner des blessures graves, voire mortelles. S'il est nécessaire de travailler avec des composants électriques sous tension, demandez à un électricien qualifié et agréé ou à une autre personne ayant la formation nécessaire pour manipuler des composants électriques sous tension d'exécuter ces tâches.

The compressor motor(s) and the supply fan motor are internally connected for the proper rotation when the incoming power supply is phased as A to L1, B to L2, and C to L3.

Proper electrical supply phasing can be quickly determined and corrected before starting the unit by using an instrument such as an Associated Research Model 45 Phase Sequence Indicator and following these steps:

- Turn off the main source feeding power to the unit field-supplied or factory-installed main disconnect device (switch or circuit breaker).
- Close the unit disconnect device cover, leaving disconnect switch in the off position, and turn main source power on.
- Observe the ABC and CBA phase indicator lights on the face of the sequencer. The ABC indicator light will glow if the phase is ABC. If the CBA indicator light glows, turn main source power off and then open the unit main disconnect device cover and reverse any two power wires.
- Restore the main source power and recheck the phasing. If the phasing is correct, turn main source power off then open the unit main disconnect device cover, remove the phase sequence indicator, reinstall disconnect device cover and, leaving disconnect device in the off position, turn main power source to unit on.

## Compressor Crankcase Heaters

### ⚠ WARNING

#### Live Electrical Components!

Failure to follow all electrical safety precautions when exposed to live electrical components could result in death or serious injury. When necessary to work with live electrical components, have a qualified licensed electrician or other individual who has been properly trained in handling live electrical components perform these tasks.

### ⚠ AVERTISSEMENT

#### Composants électriques sous tension!

Le non-respect de toutes les consignes de sécurité lors de la manipulation de composants électriques sous tension peut entraîner des blessures graves, voire mortelles. S'il est nécessaire de travailler avec des composants électriques sous tension, demandez à un électricien qualifié et agréé ou à une autre personne ayant la formation nécessaire pour manipuler des composants électriques sous tension d'exécuter ces tâches.

To prevent injury or death from electrocution, it is the responsibility of the technician to recognize this hazard and use extreme care when performing service procedures with the electrical power energized.

Each compressor shall be equipped with a crankcase heater. The proper operation of the crankcase heater is important to maintain an elevated compressor oil temperature during the "Off" cycle to reduce oil foaming during compressor starts. Oil foaming occurs when refrigerant condenses in the compressor and mixes with the oil. In lower ambient conditions, refrigerant migration to the compressor could increase.

When the compressor starts, the sudden reduction in crankcase pressure causes the liquid refrigerant to boil rapidly causing the oil to foam. This condition could damage compressor bearings due to reduced lubrication and could cause compressor mechanical failures.

Before initial start up, or if main power has been off for an extended period of time, compressor crankcase heater(s) should be operated for a minimum of 8 hours prior to compressor operation. With main power OFF, remove jumper between OAUTS terminals 9 and 10 (E-Stop). Turn main power to energize crankcase heater(s). At end of warm up period turn main power off, install 9-10 jumper, turn main power on, and resume normal operation.

Following crankcase heater warm-up, turn main power disconnect off, and install jumper on E-Stop terminals 9 and 10. Turn Main disconnect "On".

## Main Unit Display and ReliaTel Controls

When first powered "On", the controls perform self-diagnostic initialization to check that all internal controls are functional.

The Status LED located on the Main Unit Display and the Liteport LED located on the RTRM module is turned “On” within one second of power-up if internal operation is okay.

## Field-Installed Control Wiring

### **⚠ WARNING**

#### **Proper Field Wiring and Grounding Required!**

Failure to follow code could result in death or serious injury. All field wiring **MUST** be performed by qualified personnel. Improperly installed and grounded field wiring poses **FIRE** and **ELECTROCUTION** hazards. To avoid these hazards, you **MUST** follow requirements for field wiring installation and grounding as described in **NEC** and your local/state electrical codes.

### **⚠ AVERTISSEMENT**

#### **Câblage sur site et mise à la terre corrects nécessaires!**

Le non-respect de la réglementation peut entraîner des blessures graves, voire mortelles. Il est **IMPÉRATIF** de confier l'ensemble du câblage sur site à un électricien qualifié. Un câblage sur site mal installé ou mal mis à la terre constitue des risques **D'INCENDIE** et **D'ÉLECTROCUTION**. Pour éviter ces risques, il est **IMPÉRATIF** de respecter les obligations en matière de pose de câblage sur site et de mise à la terre tel que stipulé dans les règles du **NEC** et dans les réglementations électriques locales/nationales.

An overall layout of the various control options available with the required number of conductors for each control device is illustrated in [Figure 13, p. 27](#).

**Note:** All field wiring must conform to **NEC** guidelines as well as state and local codes.

## Control Power Transformer

### **⚠ WARNING**

#### **Hazardous Voltage!**

Failure to disconnect power before servicing could result in death or serious injury. Disconnect all electric power, including remote disconnects before servicing. Follow proper lockout/tagout procedures to ensure the power can not be inadvertently energized.

### **⚠ AVERTISSEMENT**

#### **Risque d'électrocution!**

Le non-respect de cette consigne peut entraîner des blessures graves, voire mortelles. Avant toute intervention, coupez l'alimentation électrique, y compris aux sectionneurs à distance. Suivez scrupuleusement les procédures de verrouillage/mise hors service préconisées pour empêcher tout rétablissement accidentel de l'alimentation électrique.

The 24-volt control power transformers are to be used only with the accessories called out in this manual. Transformers rated greater than 50 VA are equipped with internal circuit breakers. If a circuit breaker trips, turn “Off” all power to the unit before attempting to reset it.

The transformers are located in the control panel. The circuit breaker is located on the left side of the transformers and can be reset by pressing in on the black reset button.

## Controls Using 24 Vac

### **⚠ WARNING**

#### **Hazardous Voltage!**

Failure to disconnect power before servicing could result in death or serious injury. Disconnect all electric power, including remote disconnects before servicing. Follow proper lockout/tagout procedures to ensure the power can not be inadvertently energized.

### **⚠ AVERTISSEMENT**

#### **Risque d'électrocution!**

Le non-respect de cette consigne peut entraîner des blessures graves, voire mortelles. Avant toute intervention, coupez l'alimentation électrique, y compris aux sectionneurs à distance. Suivez scrupuleusement les procédures de verrouillage/mise hors service préconisées pour empêcher tout rétablissement accidentel de l'alimentation électrique.

### **NOTICE**

#### **Use Copper Conductors Only!**

Failure to use copper conductors could result in equipment damage as unit terminals are not designed to accept other types of conductors.

Before installing any connecting wiring, refer to [Figure 12, p. 22](#) for the electrical access locations provided on the unit and [Table 3](#) for AC conductor sizing guidelines, and:

1. Use copper conductors unless otherwise specified.
2. Ensure that the AC control wiring between the controls and the unit's termination point does not exceed three (3) ohms/ conductor for the length of the run.

## Installation

**Note:** Resistance in excess of 3 ohms per conductor may cause component failure due to insufficient AC voltage supply.

- Be sure to check all loads and conductors for grounds, shorts, and mis-wiring.
- Do not run the AC low-voltage wiring in the same conduit with the high-voltage power wiring.

**Table 3. 24 Vac conductors**

Distance from Unit to Control	Recommended Wire Size
000–460 feet 000–140 m	18 gauge 0.75 mm <sup>2</sup>
461–732 feet 104–223 m	16 gauge 1 mm <sup>2</sup>

### Controls Using DC Analog Input/Output (Standard Low Voltage Multiconductor Wire)

#### ⚠ WARNING

##### Hazardous Voltage!

Failure to disconnect power before servicing could result in death or serious injury. Disconnect all electric power, including remote disconnects before servicing. Follow proper lockout/tagout procedures to ensure the power can not be inadvertently energized.

#### ⚠ AVERTISSEMENT

##### Risque d'électrocution!

Le non-respect de cette consigne peut entraîner des blessures graves, voire mortelles. Avant toute intervention, coupez l'alimentation électrique, y compris aux sectionneurs à distance. Suivez scrupuleusement les procédures de verrouillage/mise hors service préconisées pour empêcher tout rétablissement accidentel de l'alimentation électrique.

Before installing any connecting wiring between the unit and components utilizing a DC analog input/output signal, refer to [Figure 12, p. 22](#) for the electrical access locations provided on the unit.

- [Table 4](#) lists the conductor sizing guidelines that must be followed when interconnecting the DC binary output devices and the system components utilizing a DC analog input/output signal to the unit.

**Note:** Resistance in excess of 2.5 ohms per conductor can cause deviations in the accuracy of the controls.

- Ensure that the wiring between controls and the unit's termination point does not exceed 2.5 ohms/conductor for the length of the run.
- Do not run the electrical wires transporting DC signals in or around conduit housing high voltage wires.

## DC Conductors

**Table 4. Zone sensor module wiring**

Distance from Unit to Control	Recommended Wire Size
000–150 feet 0–45.7 m	22 gauge 0.33 mm <sup>2</sup>
151–240 feet 46–73.1 m	20 gauge 0.50 mm <sup>2</sup>
241–385 feet 73.5–117.3 m	18 gauge 0.75 mm <sup>2</sup>
386–610 feet 117.7–185.9 m	16 gauge 1.3 mm <sup>2</sup>
611–970 feet 186.2–295.7 m	14 gauge 2.0 mm <sup>2</sup>

**Figure 13. OAUTS Connection B**

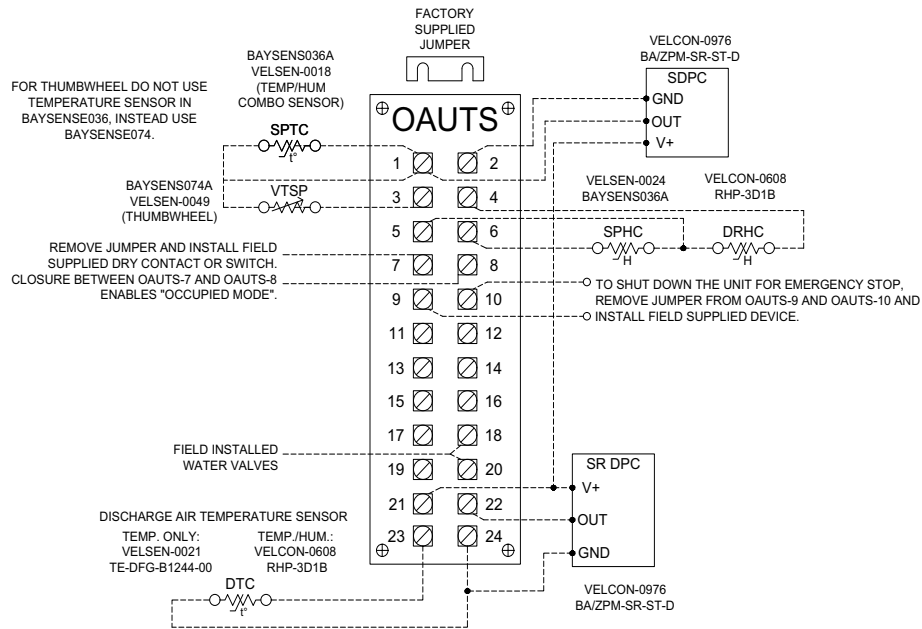



# System Configuration and Pre-Start

The following procedure must be completed prior to performing the procedure in the Start-up chapter. This section describes procedures to navigate the various displays on the Unit Display and configure the Outdoor Air Unit Main Unit Display system setpoints and operating parameters.

**Important:** This section is intended to provide guidelines for navigation through the remote operator

display screens. For additional control system information, refer to Integration Guide: Tracer™ UC600 Programmable Controller for Packaged Outdoor Air Unit (BAS-SVP18\*-EN). The unit is configured at the factory with the default settings.

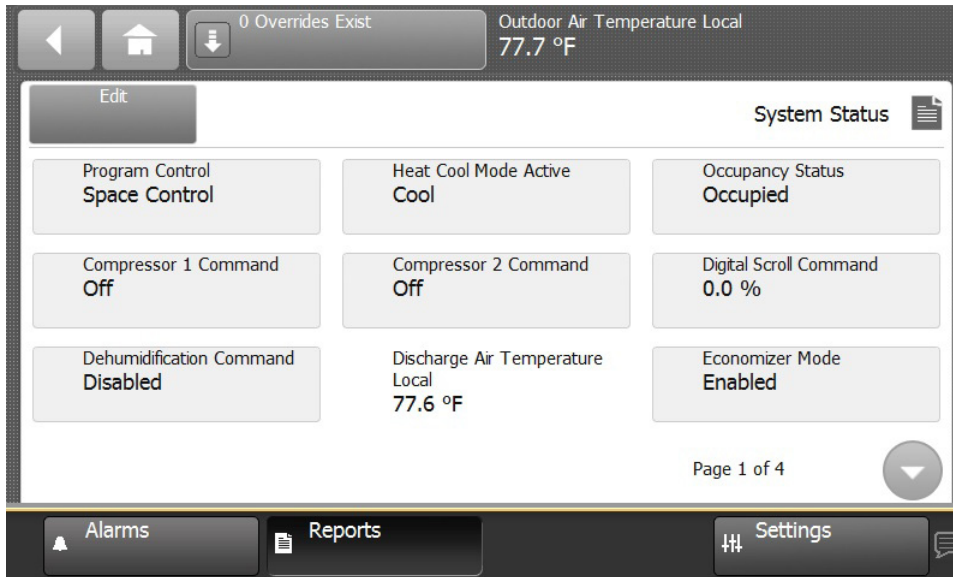

**Table 5. Chart of analog and binary input/output**

#	BACnet Point Name	Write	Default	Range	Units	Description
AI-01	Space Temperature Local			40–95	°F	Hardwired input from field installed space temperature sensor, wired to OAUTS-1 & -2 (SPTC).
AI-02	Space Humidity Local			0–100	%	Hardwired input from field installed space humidity sensor, wired to OAUTS-5 & -6 (SPHC).
AI-03	Supply Fan Piezo Pressure Local			0–25	in.H <sub>2</sub> O	Hardwired input from factory installed piezo differential pressure sensor (SPZ).
AI-04	Outdoor Coil Leaving Temperature Circuit 1 Local			-50–270	°F	Hardwired input from factory installed temperature sensor located on the outdoor coil (CCTC1).
AI-05	Outdoor Coil Leaving Temperature Circuit 2 Local			-50–270	°F	Hardwired input from factory installed temperature sensor located on the outdoor coil (CCTC2).
AI-06	Return Air Temperature Local			-40–135	°F	Hardwired input from factory installed temperature sensor located in the return air path (RTC).
AI-07	Outdoor Air Damper Position Status Local			0-100	%	Hardwired input that provides feedback status from the actuator located on the outdoor air damper (OAD).
AI-08	Space CO <sub>2</sub> Concentration Local			-	ppm	Hardwired input from field provided CO <sub>2</sub> .
AI-09	Exhaust Fan Piezo Pressure Local			0–25	in.H <sub>2</sub> O	Hardwired input from factory installed piezo differential pressure sensor (EPZ).



**Table 5. Chart of analog and binary input/output (continued)**

#	BACnet Point Name	Write	Default	Range	Units	Description
AI-10	Outdoor Airflow Local			—	cfm	Hardwired input from factory outdoor airflow monitoring station (AMS).
AI-11	Discharge Air Temperature Local			-40–150	°F	Hardwired input from field installed discharge air temperature sensor wired to OAUTS-23 & -24 (DTC).
AI-12	Return Duct/Space Pressure Local			0–2	in.H <sub>2</sub> O	Hardwired input from field installed transducer mounted in the return air duct (RDSPC).
AI-13	Exhaust Leaving Temperature Local			-40–130	°F	Hardwired input from factory installed temperature sensor located between the energy recovery wheel and the exhaust fan (EXTC).
AI-14	Return Air Humidity Local			0–100	%	Hardwired input from factory installed humidity sensor located in the return air path (RRHC).
AI-15	Indoor Coil Leaving Air Temperature Local			-40–160	°F	Hardwired input from factory installed temperature sensor located between the cooling and the hot gas reheat coils (ICTC).
AI-16	Suction Line Refrigerant Pressure Circuit 2 Local			0–150	psi	Hardwired input from factory installed pressure transducer on the refrigeration circuit (SLPC2).
AI-17	Energy Recovery Supply Air Leaving Temperature Local			-40–130	°F	Hardwired input from factory installed temperature sensor located between the energy recovery wheel and the indoor coil (ERSTC).
AI-18	Liquid Line Refrigerant Pressure Circuit 1 Local			0–500	psi	Hardwired input from factory installed pressure transducer on the refrigeration circuit (LLPC1).
AI-19	Liquid Line Refrigerant Pressure Circuit 2 Local			0–500	psi	Hardwired input from factory installed pressure transducer on the refrigeration circuit (LLPC2).
AI-20	Space Temperature Setpoint Local			55–85	°F	Hardwired input for field installed thumbwheel input wired to OAUTS-3 (VTSP).
AI-21	Outdoor Air Temperature Local			-40–130	°F	Hardwired input for factory installed temperature sensor reading outdoor air (OTC).
AI-22	Outdoor Air Relative Humidity Local			0–100	%	Hardwired input for factory installed humidity sensor reading outdoor air (ORHC).
AI-23	Duct Static Pressure Local			0–2	in.H <sub>2</sub> O	Hardwired input for field installed supply duct static pressure wired to OAUTS-1 & -2 (SDPC).
AI-24	Exhaust/Return Pressure Differential Local			0–1	in.H <sub>2</sub> O	Local pressure differential between return and exhaust.
AI-25	Preheat Leaving Coil Temperature Local			-58–350	°F	Local temperature sensor after the pre-heater.
AI-26	Mixed Air Temperature Local			-50–150	°F	Local averaged temperature sensor before entering the indoor coil.
AI-27	Discharge Air Humidity Local			0–105	%	Local discharge air humidity sensor.
AI-28	Suction Line Refrigerant Pressure Circuit 1 Local			0–150	psi	Hardwired input from factory installed pressure transducer on the refrigeration circuit (SLPC1).
AO-01	Hot Gas Reheat Valve Command			0–100	%	Analog hot gas reheat output.
AO-02	Supply Fan Speed Command			0–100	%	Supply fan speed output.



## System Configuration and Pre-Start

**Table 5. Chart of analog and binary input/output (continued)**

#	BACnet Point Name	Write	Default	Range	Units	Description
AO-03	Compressor Speed Command Circuit 1			0–100	%	Speed control for circuit 1 digital scroll or variable speed compressor.
AO-04	Exhaust Fan Speed Output Command			0–100	%	Exhaust fan speed output
AO-05	Outdoor Air Damper Position Command			0–100	%	Position command for outdoor air damper. Return air damper position is inverse to this output.
AO-06	Energy Recovery Outdoor Air Bypass Position Command			0–100	%	Analog output for modulating ERV outdoor air bypass.
AO-07	Condenser Fan Speed Command			0–100	%	Analog condenser fan speed command.
AO-08	Compressor Speed Command Circuit 2			0–100	%	Speed control for circuit 1 digital scroll or variable speed compressor.
AO-09	Chilled Water Valve Command			0–100	%	Analog chilled water actuator valve output command.
AO-10	Energy Recovery Wheel Speed Command			0–100	%	Analog ERV VFD command.
AO-11	Heating Output Command			0–100	%	Analog heating output command. Modulating burner only for gas heat.
AO-12	Second Stage Condenser Fan Speed Command			0–100	%	Analog condenser fan speed command for the second stage.
AO-13	Energy Recovery Exhaust Air Bypass Position Command			0–100	%	Analog output for modulating ERV exhaust air bypass.
AV-01	Occupied Cooling Setpoint	•	72°F	55–85	°F	Space cooling setpoint used in occupied mode.
AV-02	Occupied Heating Setpoint	•	70°F	55–85	°F	Space heating setpoint used in occupied mode.
AV-04	Heat Pump Disable Temperature	•	25°F	0–60	°F	Heat pump operation is disabled when the outdoor air temperature falls below this setpoint.
AV-05	Dehumidification Temperature Active			-58–482	°F	Temperature reading for dehumidification. For OAN Rev. 6 cabinets this is discharge air dewpoint, all other it's indoor coil leaving temperature.
AV-07	Space Humidity Active			0–100	%	Actively used space relative humidity.
AV-08	Space Humidity BAS	•		0–100	%	Communicated space relative humidity. Takes priority over hardwired input when put In Service.
AV-10	Outdoor Air Dewpoint Enable Setpoint	•	55°F	45–100	°F	Setpoint used to put the unit into dehumidification.
AV-11	Outdoor Air Dewpoint			-10–150	°F	Dewpoint of the outdoor air. This point is calculated within the program.
AV-12	Exhaust Fan Tracking Offset Setpoint	•	0.9	0–150	%	Setpoint used to track with the supply fan speed. Factory default is Out of Service. When put In Service it takes priority over other exhaust fan control schemes.
AV-13	Supply Fan Airflow Minimum Setpoint - Heating Mode		0	Varies	cfm	Setpoint used for supply fan during heating mode (not heat pump).
AV-14	Dehumidification Temperature Setpoint	•	46	40–75	°F	Setpoint used during dehumidification.

**Table 5. Chart of analog and binary input/output (continued)**

#	BACnet Point Name	Write	Default	Range	Units	Description
AV-16	Occupied Offset	•	2	0–18	Δ°F	Offset used to switch between modes of operation.
AV-17	Supply Fan Speed Setpoint	•	1	50–100	%	Setpoint used for constant speed supply fan.
AV-18	Compressor Heating Capacity			0–100	%	Compressor Heating source capacity.
AV-19	Damper Control P-Gain	•	4	0–16		P-Gain used for outdoor air damper operation.
AV-20	Space Temperature BAS			40–95	°F	Communicated space temperature. Takes priority over hardwired input when put In Service.
AV-21	Compressor Low Ambient Lockout	•	55°F	50–75	°F	Setpoint used to lock out compressor operation on units without head pressure control.
AV-23	Space Temperature Active			40–95	°F	Actively used space temperature.
AV-24	Discharge Air Dewpoint			-58–482	°F	Active discharge air dewpoint temperature.
AV-25	Space Temperature Setpoint BAS	•	72°F	62–80	°F	Communicated space temperature setpoint.
AV-26	Unoccupied Cooling Enable Setpoint	•	80°F	60–90	°F	Space cooling setpoint used in unoccupied mode.
AV-27	Unoccupied Heating Enable Setpoint	•	65°F	45–90	°F	Space heating setpoint used in unoccupied mode.
AV-28	Unoccupied Dewpoint Enable Setpoint	•	65°F	49–100	°F	If the space dewpoint rises above this setpoint during unoccupied mode then dehumidification will be enabled.
AV-29	Outdoor Air Cooling Enable Setpoint	•		45–100	°F	Setpoint used to lock the unit into cooling mode. User input with Discharge Control, calculated value on other units.
AV-30	Discharge Air Cooling Setpoint BAS	•	60°F	45–90	°F	Discharge air setpoint during cooling mode.
AV-32	Discharge Air Heating Setpoint BAS	•	65°F	45–100	°F	Discharge air setpoint during heating mode.
AV-33	Outdoor Air Heating Enable Setpoint	•		15–75	°F	Setpoint that puts the unit into heating mode. User input with Discharge Control, calculated value on other units.
AV-34	Calculated Space Dewpoint Setpoint		58°F	42–80	°F	Calculated setpoint using Space Temperature Setpoint Active and Space Humidity Setpoint. Puts the unit into dehumidification.
AV-35	Space Dewpoint			-500–482	°F	Actively used space dewpoint.
AV-37	Space Temperature Setpoint Active			45–95	°F	Actively used space temperature setpoint from Space Temperature Setpoint BAS, or from Occupied Cooling or Heating Setpoint based on mode.
AV-38	Outdoor Airflow Active			0–25000	cfm	Actively used outside airflow.
AV-39	Supply Fan Airflow Setpoint	•		0–25000	cfm	Setpoint used to control the supply fan for constant volume, or maximum limit for VAV units.
AV-40	Exhaust Fan Speed Setpoint BAS	•	0.8	0–100	%	Setpoint used for constant speed exhaust fan.
AV-41	Supply Fan Airflow Active			0–26000	cfm	Actively used supply airflow. Calculated using the supply fan piezo pressure.
AV-42	Space CO2 Concentration BAS	•			ppm	Communicated space CO2 conditions.
AV-43	Discharge Air Temperature Setpoint Minimum	•	50°F	40–65	°F	Setpoint used to limit the discharge air temperature reset.



## System Configuration and Pre-Start

**Table 5. Chart of analog and binary input/output (continued)**

#	BACnet Point Name	Write	Default	Range	Units	Description
AV-44	Heat Capacity			0–100	%	Primary heating source capacity.
AV-45	Discharge Air Temperature Setpoint Maximum	•	120°F	80–120	°F	Setpoint used to limit the discharge air temperature reset.
AV-46	Duct Static Pressure Setpoint BAS	•	1.5	-1–6	in.H <sub>2</sub> O	Setpoint used to control supply fan to static pressure.
AV-47	Outdoor Air Damper Maximum Position Setpoint	•	1	0–100	%	Setpoint used to limit the outdoor air damper position during all operation.
AV-48	Outdoor Air Damper Minimum Position Setpoint	•		0–100	%	Setpoint used to limit the outdoor air damper position during all operation.
AV-50	Space CO <sub>2</sub> Concentration Setpoint	•	500	0–3000	ppm	Setpoint used to control the outdoor air damper.
AV-51	Cool Control Pgain		4	0–12		Pgain used to control the compressors.
AV-52	Cooling Capacity			0–500	%	Active cooling capacity of the unit.
AV-54	Exhaust Fan Airflow Active			0–26000	cfm	Actively used exhaust airflow. Calculated using the supply fan piezo pressure.
AV-55	Direct Fired Profile Width	•		6–28		Width of the profile opening for direct fired heaters. Used to calculate airflow.
AV-56	Return Duct/Space Pressure Setpoint	•	0.5	-1–3	in.H <sub>2</sub> O	Setpoint used for exhaust fan static pressure control.
AV-57	Exhaust Fan Airflow Setpoint	•		0–25000	cfm	Setpoint used for constant volume exhaust fan control.
AV-59	Supply Fan Airflow Minimum Setpoint - Cooling Mode		0		cfm	Setpoint used for supply fan during cooling or heat pump operation.
AV-61	Heat Control Pgain	•	4	0–6		Pgain used to control primary heat.
AV-62	Space CO <sub>2</sub> Concentration Active			0–10000	ppm	Actively used space CO <sub>2</sub> conditions.
AV-63	Heat Pump Fail Switch Point			-58–482	°F	Outdoor air temperature at which the heat pump failed to meet setpoint.
AV-64	Duct Static Pressure BAS	•		-6–6	in.H <sub>2</sub> O	Communicated duct static pressure. Factory defaulted Out of Service. When put In Service it takes priority over hardwired input.
AV-65	Duct Static Pressure Active			-6–6	in.H <sub>2</sub> O	Actively used duct static pressure.
AV-66	Discharge Air Temperature Setpoint Active			38–130	°F	Actively used discharge air temperature setpoint. For Space Control and Single Zone VAV this is reset within the program.
AV-67	Discharge Air Temperature Setpoint BAS	•	55°F	40–125	°F	Communicated discharge air temperature setpoint. Factory default Out of Service. When put In Service it replaces Discharge Air Cooling and Heating Setpoints.
AV-68	Outdoor Air Enthalpy Active				BTU/lb	Actively used outdoor air enthalpy.
AV-71	Outdoor Airflow Setpoint BAS	•		0–25000	cfm	Setpoint to modulate the dampers.
AV-72	Return Air Enthalpy Active				BTU/lb	Actively used outdoor air enthalpy.

**Table 5. Chart of analog and binary input/output (continued)**

#	BACnet Point Name	Write	Default	Range	Units	Description
AV-74	Supply Fan Airflow Minimum Setpoint Active			0–25000	cfm	Actively used setpoint. Controlled by program from minimum setpoints for heating and cooling mode.
AV-75	Outdoor Air Temperature BAS	•		-40–135	°F	Optional communicated outdoor air temperature.
AV-76	Outdoor Air Temperature Active			-100–200	°F	Actively used outdoor air temperature.
AV-77	Dehumidification Temperature Setpoint Active		48°F	38–75	°F	Actively used setpoint during dehumidification.
AV-81	Outdoor Air Humidity BAS	•	0.5	0-100	%	Optional communicated outdoor air relative humidity.
AV-82	Outdoor Air Humidity Active		0.45	0-100	%	Actively used outdoor air relative humidity.
AV-87	Space Humidity Setpoint	•	0.45	0–100	%	Setpoint used to calculate Space Dewpoint Setpoint.
AV-88	Condenser Fan P-Gain	•	4	0–10		Pgain used to control condenser fans
BI-01	Supply Fan Status			0=Off 1=On		Status of the supply fan using a differential pressure switch.
BI-02	Emergency Stop			0=Normal 1=ESTOP		Auto Reset. Shuts the unit down.
BI-03	Final Filter Status			0=Clean 1=Clogged		Auto Reset. Notification when differential pressure switch closes (adj. range) for the filters in front of the indoor coil.
BI-04	Occupancy Input			0=Unocc. 1=Occupied		Dry contact input for Occupancy Status. Wired to field wiring terminal strip OAUTS-7 & 8. To use MV-01 keep factory installed jumper in place.
BI-05	Outdoor Air Damper End Switch			0=Not Proven 1=Proven		End switch for outdoor air damper.
BI-06	Heat On Off Status Local			0=Off 1=On		Auto Reset (4 hours). Occurs when there is a call for heat but the heat status relay is not energized. The heat is cycled three times and then locked out for four hours before retrying.
BI-07	Exhaust Damper End Switch			0=Not Proven 1=Proven		End switch for isolation dampers for the exhaust fan.
BI-08	Outdoor Coil Water Flow Status			0=Off 1=On		Water flow status for outdoor water coil using a differential pressure switch.
BI-09	Outdoor Coil Water Low Temperature Switch			0=Open 1=Closed		Low temperature safety switch for outdoor water coil.
BI-10	Condensate Detection Input			0=Normal 1=InAlarm		Auto Reset.
BI-11	Indoor Coil Frost			0=Clean 1=Frost		Auto Reset.
BI-12	Energy Recovery Wheel Outdoor Air Filter Status			0=Clean 1=Clogged		Auto Reset. Notification when differential pressure switch closes (adj. range) for the filters before ERV on outdoor air side.
BI-13	Energy Recovery Wheel Return Air Filter Status			0=Clean 1=Clogged		Auto Reset. Notification when differential pressure switch closes (adj. range) for the filters before ERV on return air side.



## System Configuration and Pre-Start

**Table 5. Chart of analog and binary input/output (continued)**

#	BACnet Point Name	Write	Default	Range	Units	Description
BI-14	Exhaust Fan Status			0=Off 1=On		Status of the exhaust fan using a differential pressure switch.
BI-15	Energy Recovery Wheel Rotation Status			0=Off 1=On		Status of the energy recovery wheel using a proximity sensor.
BI-16	Hot Water Freezestat			0=Normal 1=Freezing		Manual Reset. Shuts the unit down.
BI-17	Compressor 1 Status			0=On 1=Off		Feedback run status hardwired through compressor contactor.
BI-18	Compressor 2 Status			0=On 1=Off		Feedback run status hardwired through compressor contactor.
BI-19	Compressor 3 Status			0=On 1=Off		Feedback run status hardwired through compressor contactor.
BI-20	Compressor 4 Status			0=On 1=Off		Feedback run status hardwired through compressor contactor.
BI-21	Compressor 5 Status			0=On 1=Off		Feedback run status hardwired through compressor contactor.
BI-22	Compressor 6 Status			0=On 1=Off		Feedback run status hardwired through compressor contactor.
BI-23	Compressor 1 VFD Status			0=Alarm 1=Normal		Compressor alarm status input from VFD.
BO-01	Supply Fan Start Stop Command			0=Off 1=On		Enable for supply fan.
BO-02	Outdoor Air Damper Open Close Command			0=Open 1=Closed		Enable for outdoor air damper.
BO-03	Heat 1 Command			0=Off 1=On		Enable for stage 1 of the primary heater.
BO-04	Inducer Command			0=Off 1=On		Output to switch stage 1 inducer fan from low to high speed.
BO-05	Compressor 3 Command			0=Off 1=On		Enable for compressor 3.
BO-06	Compressor 4 Command			0=Off 1=On		Enable for compressor 4.
BO-07	Heat 2 Command			0=Off 1=On		Enable for stage 2 heat.
BO-08	Heat 3 Command			0=Off 1=On		Enable for stage 3 heat.
BO-09	Exhaust Damper Open Close Command			0=Open 1=Closed		Output to open isolation dampers located on exhaust fan.
BO-10	Exhaust Fan Start Stop Command			0=Off 1=On		Enable for exhaust fan.
BO-11	Compressor 1 Command			0=Off 1=On		Enable for compressor 1.
BO-12	Compressor 2 Command			0=Off 1=On		Enable for compressor 2.
BO-13	Pre-Heat Enable			0=Off 1=On		Enable for electric pre-heat located in front of energy recovery wheel.
BO-14	Condenser Fan Start Stop Command			0=Off 1=On		Enable for condenser fan(s).

**Table 5. Chart of analog and binary input/output (continued)**

#	BACnet Point Name	Write	Default	Range	Units	Description
BO-15	Energy Recovery Wheel Start Stop Command			0=Off 1=On		Enable for energy recovery wheel.
BO-16	Circuit 1 Reversing Valve Command			0=Heating 1=Cooling		Output used to switch between heat pump and cooling on circuit 1.
BO-17	Circuit 2 Reversing Valve Command			0=Heating 1=Cooling		Output used to switch between heat pump and cooling on circuit 2.
BO-18	Split Exhaust-Return Damper Open Close Command			0=Open 1=Closed		Output to open damper located between split exhaust and return air paths.
BO-19	Compressor 1 VFD Reset			0=Off 1=Reset		Output to reset compressor VFD when it goes into alarm.
BO-20	Second Stage Condenser Fan Start Stop Command			0=Off 1=On		Output to enable second stage of condenser fans.
BO-21	Compressor 5 Command			0=Off 1=On		Enable for compressor 5.
BO-22	Compressor 6 Command			0=Off 1=On		Enable for compressor 6.
BV-04	Heat Pump Defrost Mode			0=Off 1=On		Defrost status for outdoor coil.
BV-05	Hot Gas Reheat Purge Mode			0=Off 1=On		Purge status for hot gas reheat.
BV-07	Auxiliary Heating Mode			0=Allowed 1=Not Allowed		Used to interlock primary heater to prevent simultaneous heat pump and primary heat operation.
BV-09	Economizer Status			0=Not Econ. 1=Econ.		Economizer status.
BV-16	Alarm Reset			0=Normal 1=Reset		Used to reset all manual reset diagnostics.
BV-17	System LOCKOUT			0=Normal 1=Lockout		Generic diagnostic accompanying diagnostics that require manual reset.
BV-18	Exhaust Fan Static Pressure Control Direction	•	Reverse	0=Reverse 1=Direct		Used to switch the exhaust fan PID for static pressure control between direct and reverse acting.
BV-20	Allow Unoccupied Operation	•	#N/A	0=Not Allowed 1=Allowed		Toggles unoccupied operation.
BV-21	Heat Cool Mode Active			0=Heat 1=Cool		Heat/cool mode status used throughout the program.
BV-23	Unoccupied Cooling Mode			0=Disabled 1=Enabled		Active status on operation in unoccupied cooling mode.
BV-25	Circuit 1 Status			0=Off 1=On		Feedback status on the circuit 1 refrigeration.
BV-27	Dehumidification Status			0=Off 1=On		Active status on operation in dehumidification mode.
BV-39	Unoccupied Heating Mode			0=Off 1=On		Heat mode status during unoccupied.
BV-40	Unoccupied Dehumid Mode			0=Off 1=On		Dehumidification mode status during unoccupied.
BV-41	Energy Recovery Frost Avoidance Status			0=Normal 1=Active		Status indicating when actively bypassing or slowing down energy recovery wheel to prevent frost accumulation.
BV-43	Ventilation Mode			0=Off 1=On		Status for ventilation mode, locking out heating and cooling.





## System Configuration and Pre-Start

**Table 5. Chart of analog and binary input/output (continued)**

#	BACnet Point Name	Write	Default	Range	Units	Description
BV-44	Free Cooling Mode			0=Off 1=On		Status for free cooling mode, using outdoor air temperature to maintain setpoint.
BV-45	Economizer Control Type	•	Enthalpy	0=DryBulb 1=Enthalpy		Used to switching between dry bulb or enthalpy economizer.
BV-49	Mixed Air Low Limit Active			0=Normal 1=Active		Auto-Reset:
BV-57	Defrost Mode Heat Enable			0=Off 1=On		Status indicating supplemental heat during outdoor coil defrost mode.
BV-61	Compressor Heating Allowed			0=Allowed 1=Not Allowed		Active status on whether heat pump is allowed.
BV-62	Compressor Cooling Allowed			0=Allowed 1=Not Allowed		Active status on whether cooling is allowed.
BV-63	Circuit 2 Status			0=Off 1=On		Feedback status on the circuit 1 refrigeration.
BV-64	Compressor Low Ambient Lockout Active			0=Active 1=Not Active		Status indicating that the unit is calling for cooling but the compressors are locked out due to low ambient temperature.
MV-01	Occupancy Request	•				1 = Occupied 2 = Unoccupied 3 = Occupied Bypass 4 = Occupied Standby 5 = Auto
MV-02	Occupancy Status					1 = Occupied 2 = Unoccupied 3 = Occupied Bypass 4 = Occupied Standby
MV-03	Heat Cool Mode Request	•				1 = Auto 2 = Heat 3 = Morning Warm-up 4 = Cool 7 = Off 10 = Fan Only 11 = Economizing 15 = Dehumidify
MV-04	Heat Cool Mode Status					See Heat Cool Mode Request (MV-03)
MV-05	Discharge Air Temperature Setpoint Source Status					1 = Discharge Air Cooling Setpoint BAS 2 = Discharge Air Heating Setpoint BAS 3 = Discharge Air Temperature Setpoint BAS 4 = Reset for Space Comfort Control
MV-06	Emergency Override BAS	•	1			1 = Normal 6 = Fire
MV-07	Space Temperature Setpoint Source Status					1 = Occupied Heating Setpoint 2 = Occupied Cooling Setpoint 3 = Thumbwheel (Space Temperature Setpoint Local) 4 = Space Temperature Setpoint BAS
MV-08	Dehumidification Temperature Source Status					1 = Discharge Air Dewpoint 2 = Indoor Coil Leaving Temperature
MV-09	Heat Type		-			Factory set heat type.
MV-10	Supply Fan Wheel Size		-			Factory set supply fan size.
MV-11	Direct Fired Burner Size		-			Factory set direct fired burner size.
MV-12	Exhaust Fan Wheel Size		-			Factory set exhaust fan size.

**Table 5. Chart of analog and binary input/output (continued)**

#	BACnet Point Name	Write	Default	Range	Units	Description
MV-13	Program Control Type	•	#N/A			1 = Space Control 2 = Discharge Control 3 = Single Zone VAV 4 = Multi Zone VAV 5 = Critical Space Control 6 = Critical Discharge Control
MV-16	Dehumidification System Status					1 = Off 2 = On
MV-17	Economizer System Status					1 = Not Economizing 2 = Economizer Mode 3 = Free Cooling Mode 4 = Ventilation Mode
MV-19	Compressor 1 Status Active					1 = Disabled 2 = Enabled, No Running Status 3 = Enabled With Running Status 4 = Enabled, No VFD Alarm 5 = Not Installed
MV-20	Compressor 2 Status Active					1 = Disabled 2 = Enabled, No Running Status 3 = Enabled With Running Status 4 = Not Installed 5 = Input Status In Fail
MV-21	Compressor 3 Status Active					See Compressor 2 Status Active MV-20
MV-23	Compressor 4 Status Active					See Compressor 2 Status Active MV-20
MV-24	Compressor 5 Status Active					See Compressor 2 Status Active MV-20
MV-25	Compressor 6 Status Active					See Compressor 2 Status Active MV-20

# Pre-Start Up

## Start-up

1. Perform Test and Balance before start up (if possible).
2. Set up Date and Time for unit, helps with diagnosis when looking at alarms and data logs.
3. Check points of interest sheet and confirm in/out of service points.
4. Verify Phase Monitor.
  - a. Check voltage.
  - b. Check Phase imbalance set to 2-3%.
  - c. Restart is set halfway between 1 to 125 seconds.
  - d. Check Trip delay is set at 30 seconds.
  - e. ESR 1/2/3 should be lit if phase monitor.
5. Check UC 600 Setpoints.
  - a. Duct Static Pressure Setpoint.
  - b. Minimum OA Damper Position.
  - c. Maximum OA Damper Position.
  - d. Supply Airflow Setpoint.
  - e. Exhaust Airflow Setpoint.
  - f. IVFD signal.
  - g. PEVFD Setpoint.
6. Identify Airflow Monitoring.
  - a. Zero out Piezo(s) before startup if applicable.
    - i. Detach clear tubing from sensor.
    - ii. Remove sensor cover.
    - iii. Press and hold the ZERO button.
    - iv. Display should read 0.00.
    - v. Put the cover back on.
    - vi. Recalibrate in TU UC600.
    - vii. Click on Supply Fan pressure if the number is not 0, right click to configure.
    - viii. Make calibration offset the opposite of the number listed as supply fan pressure.
    - ix. For example, if the supply fan pressure is listed as 0.18, set the calibration offset to -0.18 and save.
    - x. Reattach the clear tubing to the sensor securely.
    - xi. Repeat for Exhaust Piezo if applicable.

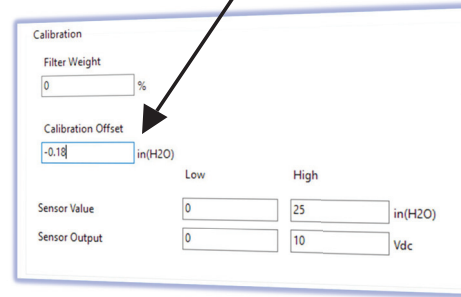
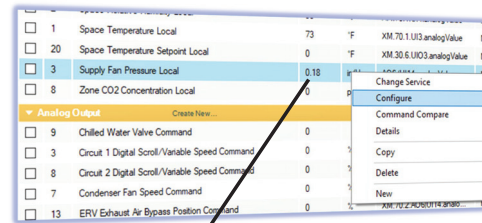

7. Identify OA/RA Dampers
  - a. Verify end switch is set to 4

## Cooling Start-up

**Important:** This Should NOT be performed if Ambient Temperatures are <65°F or >105°F.

1. Check Supply Fan RPM and Hz settings.
2. Identify Compressor Type.
  - a. If model number begins with:
    - i. ZP- Fixed Speed (one or both circuits).
    - ii. ZPD- Digital Compressor (one or both circuits).
    - iii. ZPV- Variable Speed Compressor (1st circuit only).
3. For Fixed/Digital Compressors:
  - a. Override compressor 1 ON, or compressor 1 and 2 ON in a tandem circuit.
  - b. For digital scroll, override Circuit 1 command to 100%.
  - c. Override HGRH to 25%.
  - d. Raise head pressure to 400psi.
  - e. Record electrical data, refrigerant pressures, saturated temps and line temps on Horizon. Start Up sheet (available at the end of this document).
  - f. Override HGRH 100% and check refrigerant flow.
  - g. Override Compressor OFF.
  - h. Repeat Circuit 2 (if applicable) Variable Speed Compressor.
4. Variable Speed Compressor.
  - a. Override Compressor 1 ON.
  - b. Override Circuit 1 to 0%.
  - c. Override HGRH to 100%.
  - d. Maintain head pressure 400 psi.

- e. Record electrical data, refrigerant pressures, saturated temps and line temps on Horizon. Start Up sheet (available at the end of this document).



# Start-Up

## Direct Heating Start-up

### **⚠ WARNING**

#### **Hazardous Service Procedures!**

Failure to follow all precautions in this manual and on the tags, stickers, and labels could result in death or serious injury.

- Technicians, in order to protect themselves from potential electrical, mechanical, and chemical hazards, **MUST** follow precautions in this manual and on the tags, stickers, and labels, as well as the following instructions: Unless specified otherwise, disconnect all electrical power including remote disconnect and discharge all energy storing devices such as capacitors before servicing. Follow proper lockout/tagout procedures to ensure the power can not be inadvertently energized. When necessary to work with live electrical components, have a qualified licensed electrician or other individual who has been trained in handling live electrical components perform these tasks.
- Do not attempt the following procedures until all electrical and gas connections to the unit have been completed and the outdoor air damper and evaporator fan operation have been verified and are operating correctly.

### **⚠ AVERTISSEMENT**

#### **Procédures d'entretien dangereuses!**

Le non-respect de toutes les précautions contenues dans ce manuel ainsi que sur les étiquettes et les autocollants peut entraîner des blessures graves voire mortelles.

- Les techniciens, afin d'être protégés des éventuels risques électriques, mécaniques et chimiques, **DOIVENT** suivre les précautions contenues dans ce manuel, sur les étiquettes et les autocollants, ainsi que les instructions suivantes : Sauf indication contraire, coupez toute l'alimentation électrique y compris les disjoncteurs à distance et déchargez tous les dispositifs de stockage d'énergie comme les condensateurs avant l'entretien. Respectez les procédures de verrouillage et d'étiquetage appropriées pour éviter tout risque de remise sous tension accidentelle. S'il est nécessaire de travailler avec des composants électriques sous tension, demandez à un électricien qualifié et agréé ou à une autre personne ayant la formation nécessaire pour manipuler des composants électriques sous tension d'exécuter ces tâches.
- N'essayez pas de réaliser les procédures suivantes avant d'avoir effectué tous les raccordements en gaz et électricité sur l'unité, d'avoir inspecté le registre d'air extérieur et le ventilateur d'évaporateur et confirmé que leur fonctionnement est approprié.

### **⚠ WARNING**

#### **Hazard of Explosion!**

Failure to follow proper safe leak test procedures could result in death or serious injury or equipment or property-only-damage. **NEVER** use an open flame to detect gas leaks. You **MUST** use a leak test solution for leak testing.

### **⚠ AVERTISSEMENT**

#### **Risque d'explosion!**

Le non-respect des procédures d'essai d'étanchéité sûres recommandées pourrait provoquer des accidents graves, voire mortels, ou des dommages matériels. Ne vérifiez **JAMAIS** la présence de fuites de gaz avec une flamme nue. Vous devez **IMPÉRATIVEMENT** utiliser une solution de test d'étanchéité pour vérifier l'étanchéité.

#### **Notes:**

1. BEFORE OPERATING, leak test all gas piping up to heater gas valve. Smell around the unit area for gas. If gas is smelled, do NOT attempt to place heater in operation until source of gas leak is identified and corrected.

2. Use only hand force to operate the gas control lever to the "ON" position. NEVER use tools. If lever does not operate by hand, replace gas valve prior to starting the unit. Forcing or attempting to repair the gas valve may result in fire or explosion.
3. Do not attempt to operate unit, if there is indication that any part or control has been under water. Any control or component that has been under water must be replaced prior to trying to start the unit.

## Direct Gas-Fired Heating Start-Up Procedure

The following procedure must be followed for the unit heating section to function properly. The following procedures are to be performed after all electrical and gas connections to the unit have been completed and the outdoor air damper and evaporator fan operation have been verified and are operating satisfactorily.

Refer to Alarms and Troubleshooting chapter for additional information.

### Tools Required

- Voltage Meter ( $\mu$ A)
- Amp Meter
- Gas Pressure Gauge
- Tachometer
- Temperature Probe
- Anemometer
- Service Mirror
- Small Refrigeration Screwdriver
- 5/16-in. Nut Driver
- 1/2-in. Open End Wrench

#### 1. Confirm Unit Airflow

**Important:** Accurate airflow readings require clean inlet filters. If required clean or replace filters before proceeding.

All Horizon direct gas-fired heaters are factory-adjusted to achieve design airflow pressure drop ( $\Delta P$ ) of -0.625 in. wc across the burner profile opening at ordered unit SCFM airflow. The burner baffles should not be adjusted. Outdoor Air conditions will cause the measured  $\Delta P$  to vary. Refer to [Table 6](#) to see the acceptable measured pressures that may be read at various outdoor air conditions. Measure and record burner pressure drop.

**Table 6. Acceptable measured pressures**

OAT (°F)	Burner Pressure Drop (in. wc)
0	0.720
5	0.712
10	0.705
15	0.697
20	0.690
25	0.683
30	0.676
35	0.669
40	0.663
45	0.656
50	0.650
55	0.643
60	0.637
65	0.631
<b>70</b>	<b>0.625<sup>(a)</sup></b>
75	0.619
80	0.613
85	0.608
90	0.602
95	0.597
100	0.592

(a) 0.625-in. design pressure drop at standard air conditions.

**Note:** If burner pressure drop is not within the range shown in [Table 6](#), refer to Airflow Troubleshooting section of Alarms and Troubleshooting chapter.

#### 2. Check Inlet Gas Pressure and Confirm Gas Flow to Unit

### WARNING

#### Hazard of Explosion!

Failed gas components could explode or leak flammable gas which could cause a fire resulting in death or serious injury or property damage. Do NOT expose gas controls to pressures above 1/2 psi (3.5 kPa). Refer to General Safety Information.

### AVERTISSEMENT

#### Risque d'explosion!

Des composants au gaz défectueux peuvent exploser ou entraîner des fuites de gaz inflammable pouvant provoquer un incendie résultant en des blessures graves, voire mortelles, ou des dommages matériels. N'exposez PAS les régulations de gaz à des pressions supérieures à 1/2 psi (3,5 kPa). Reportez-vous à General Safety Information.

Confirm gas flow and gas supply pressure to heater. The Manual Shut-Off valve (MSO1) can be used to bleed the supply line as needed.

## Start-Up

After confirming gas flow to unit, verify and record gas pressure at PG1.

### 3. Heating Starting Sequence for Gas Input Rating $\leq 400$ MBh

**Important:** Open shut off valves at MSO1, MSO2, and Main Gas Valve (MGV) before proceeding.

Refer to [Figure 14](#).

**Figure 14. Burner gas train**

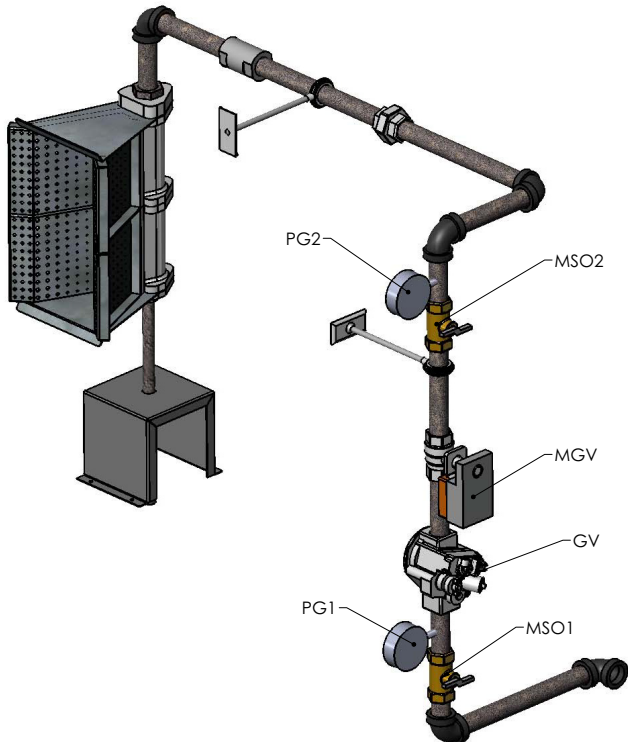

#### Burner Gas Train

- Manual Shut-off Valves (2) (MSO1 and MSO2)
  - Main Gas Valve—Automatic Safety On-Off with Main Gas Regulator
  - Modulating Gas Valve (MGV)
  - Gas Pressure Gauges
  - Main Gas Inlet Pressure (PG1)
  - Burner Inlet Pressure (PG2)
- The Main Gas Valve/Pressure Regulator (GV) and Modulating Gas Valve (MGV) have been factory set to achieve both proper maximum and proper minimum fuel input to the direct gas-fired burner.
  - Gas supply train includes (2) factory installed pressure gauges. Gauge 1 (PG1) reads the main gas supply pressure. Gauge 2 reads the outlet pressure to the burner from the MGV.
  - See Heater Burner Data Plate for factory pressure settings.
  - Electrical control panel includes control relays with pilot lights which, when illuminated, indicate the relay is energized. For this starting sequence relays controlling Outdoor Air Damper (R1), Indoor Fan (R2), Heating Call (R6), Burner Proving (R7) and Burner ON (R8) will be used.

#### • Starting Sequence

**Note:** In the event Outdoor Air Conditions or Unit Controls are such that the unit will not automatically enter the desired operating modes, refer to Alarms and Troubleshooting chapter for Control Override Procedures. For initial heating start-up, it may be necessary to remove and repeat the call for heat until the internal gas piping system is bled.

- R1 ON—OA damper OPEN
- R2 ON—Indoor Fan ON
- R6 ON—Call for Heating ON
- R7 ON—Ignition Process begins and requires proof of flame at burner to continue
- R8 ON—Ignition Process Proven

#### 4. Test Operating Heating Modes

**Note:** Heating default control signal is 25 percent for 90 seconds following successful ignition.

##### Important:

- This test is designed to assure adequate stable gas pressure is available when burner is firing at maximum capacity. Refer to unit nameplate rating for “Minimum Gas Supply Pressure Required to Achieve Maximum Temperature Rise.”
- Depending on outdoor temperature, it may be necessary to bypass the manual reset High Temperature Limit control during this test.
  - a. High Fire Test Following Normal Burner Starting Sequence
    - i. At ROD override, Heating Control Signal to 100 percent.
    - ii. When pressure at PG2 stabilizes, confirm PG1 and PG2 pressures are within  $\pm 5$  percent of the pressures shown on Burner Data Plate.

### **⚠ WARNING**

#### **Hazard of Explosion!**

Failed gas components could explode or leak flammable gas which could cause a fire resulting in death or serious injury or property damage. To avoid damage to unit if PG1 or PG2 exceed data plate pressures +5 percent, disable incoming gas using the manual shutoff valves and ensure incoming pressure is within nameplate data BEFORE enabling the gas.



## ⚠ AVERTISSEMENT

### Risque d'explosion!

Des composants au gaz défectueux peuvent exploser ou entraîner des fuites de gaz inflammable pouvant provoquer un incendie résultant en des blessures graves, voire mortelles, ou des dommages matériels. Pour éviter d'endommager l'unité si PG1 ou PG2 dépasse les pressions nominales indiquées sur la plaque signalétique de plus de 5 %, désactivez l'arrivée en gaz au moyen des vannes d'arrêt manuel et assurez-vous que la pression entrante est conforme aux valeurs indiquées sur la plaque signalétique AVANT d'activer l'arrivée en gaz.

- iii. Record Gas Pressures
  - PG1
  - PG2
- iv. At ROD, read and record
  - Outdoor Air Temperature
  - Discharge Air Temperature
  - Burner  $\Delta P$
- v. Release Heating Control Signal Override
- b. Low Fire Test Following Normal Burner Starting Sequence
  - i. Override Heating Control Signal to 0 percent
  - ii. Confirm PG1 and PG2 pressures are within  $\pm 5$  percent of the pressures shown on Burner Data Plate
  - iii. Allow a minimum of 5 minutes of operation at 0 percent heating signal
  - iv. At ROD read and record
    - Outdoor Air Temperature
    - Discharge Air Temperature
    - Burner  $\Delta P$
  - v. Record Gas Pressures
    - PG1
    - PG2
- c. Ignition Cycle Test
  - i. Release Heating Control Signal Override
  - ii. Complete at least (5) calls for heat
    - At each call for heat default heating start-up, signal is 25 percent
    - Following each ignition test and before attempting the next test monitor analogue Heating Control Signal at ROD to be sure heat signal is released at end of each 90-second warm-up period

### 5. Burner Gas Train, Ignition Controls and Starting Sequence for Gas Input Rating > 400 MBh

Refer to [Figure 15](#).

Figure 15. > 400 MBh Gas train

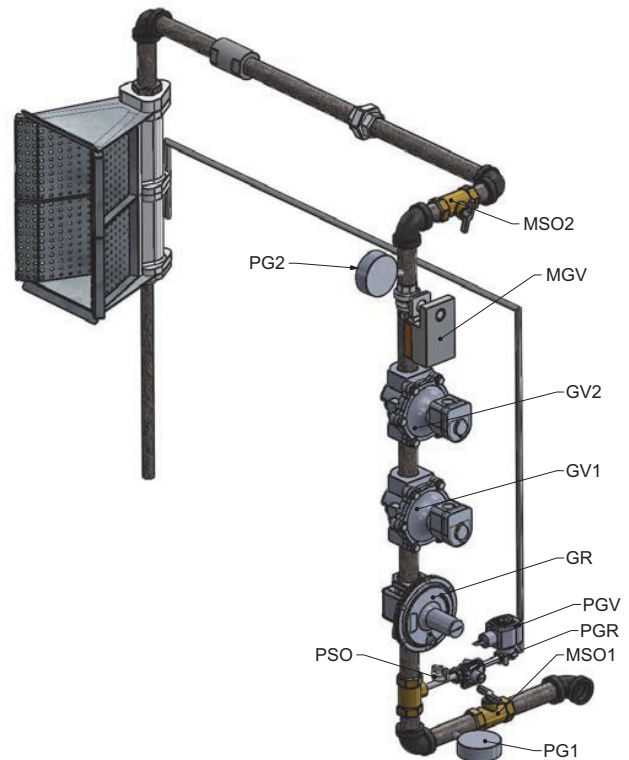

- a. Pilot Gas Train
  - i. Manual Shut-Off Valve (MSO)
  - ii. Pilot Gas Regulator (PGR)
  - iii. Pilot On-Off Valve (PGV)
- b. Burner Gas Train
  - i. Manual Shut-off Valves (2) (MSO1 and MSO2)
  - ii. Main Gas Regulator (1) (GR)
  - iii. Main Gas Valves—Automatic Safety On-Off Control (2) (GV1 and GV2)
  - iv. Modulating Gas Valve (MGV)
  - v. Gas Pressure Gauges
    - Gas Supply Pressure (PG1)
    - Burner Inlet Pressure (PG2)
- c. Burner Control Operation
 

The RM7895, EC7895, and RM7896 have the operating sequence as shown in [Figure 16, p. 44](#) and [Figure 17, p. 45](#). The LED provides positive visual indication of the program sequence for power, pilot, flame, main, and alarm.

### Initiate

The relay module enters the initiate sequence when it is powered. The RM7895A/B/C/D, EC7895A/C and RM7896A/

B/C/D can also enter the initiate sequence if the relay module verifies voltage fluctuations of +10/-15 percent or frequency fluctuations of  $\pm 10$  percent during any part of the operating sequence. The initiate sequence lasts for 10 seconds unless the voltage or frequency tolerances are not met. When not met, a hold condition is initiated and displayed on the optional KDM for at least five seconds. When met, the initiate sequence restarts. If the condition is not corrected and the hold condition exists for 4 minutes, the flame relay module locks out.

Causes for a hold condition in the initiate sequence are as follows:

- AC line dropout detection.
- AC line noise that can prevent a sufficient reading of the line voltage inputs.
- Low line voltage brownouts.

## Standby

The flame relay module is ready to start an operating sequence when the operating control input determines a call for heat is present. The burner switch, limits, operating limit control and all microcomputer-monitored circuits must be in the correct state for the relay module to continue into the “pre-purge” sequence.

## Normal Start-up Pre-purge

The module provides 30-second “pre-purge” timing with power applied and the operating control indicating a call for heat.

- The airflow interlock, burner switch, and all microcomputer-monitored circuits must also be in the correct operating state.
- The pre-purge sequence begins on call for heating.
- Failure to establish airflow at unit airflow proving switch within 15 seconds of indoor fan enable discontinues ignition.

## Ignition Trials

The pilot flame establishing period (PFEP) begins when:

- The pilot valve and ignition transformer, terminals 8 and 10, are energized. The RM7895A/B, EC7895A, and RM7896A/B modules have an intermittent pilot valve, (terminal 8). The RM7895C/D, EC7895C, and RM7896C/D modules have an interrupted pilot valve (terminal 8).
- Flame must be proven by the end of the 15-second PFEP (4 seconds if configuration jumper, JR1, is clipped) to allow the sequence to continue. If a flame is not proven by the end of PFEP, a safety shut down occurs.

With flame proven, the ignition, terminal 10, is energized. This main flame establishing period (MFEP) begins when:

- After ignition trials, and with the presence of flame, the main fuel valve, terminal 9, is powered. If a flameout occurs, the relay module locks out or recycles (depending on status of jumper JR2) within 0.8 or 3 seconds, depending on the flame failure response time (FFRT) of the amplifier.

- The RM7895C/D, EC7895C, and RM7896C/D modules have a 10-second MFEP. After ignition trials and with the presence of flame, the main fuel valve, terminal 9, is powered. If the flameout occurs, the relay module locks out within 0.8 or 3 seconds, depending on the amplifier FFRT.

## Run

The RM7895C/D, EC7895C, RM7896C/D has a delayed main valve that is energized once the “run” period is entered.

The relay module is now in “run” and remains in “run” until the controller input, terminal 6, opens, indicating that the demand is satisfied or a limit has opened.

**Run/Test Switch (RM7895C/D, EC7895C, RM7896C/D only):** The “run/test switch” is located on the top side of the relay module. This switch allows the burner sequence to be altered as follows:

- In the measured “pre-purge” sequence, the “run/test switch,” placed in the “test” position, causes the prepurge timing to stop.
- In the “pilot flame establishing period” sequence, the “run/test switch,” placed in the “test” position, stops the timer during the first 8 seconds of a 10-second PFEP selection, or during the first 3 seconds of a 4-second PFEP.
- It also allows for pilot turn-down test and other burner adjustments. This activates a 15-second flameout timer that permits pilot flame adjustment without nuisance safety shutdowns. The run/test/switch is ignored during PFEP for the C and D relay modules if terminals 8 and 9, or 9 and 21 are jumpered.

**Note:** When the relay module is switched to the “test” mode, it stops and holds at the next run/test switch point in the operating sequence. Ensure that the run/test switch is in the “run” position before leaving the installation.

**Figure 16. Sequence status LEDs**

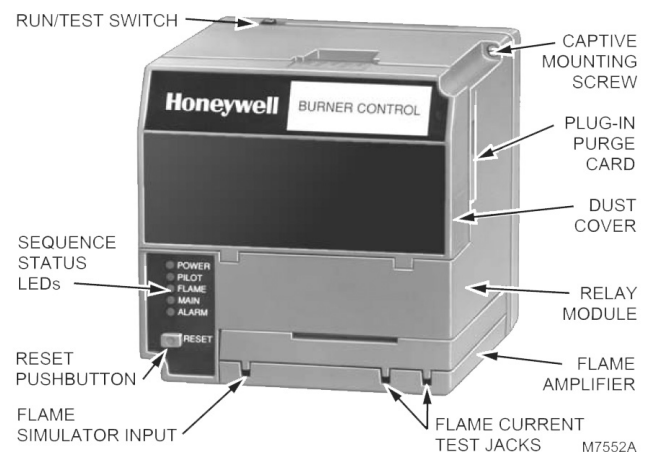

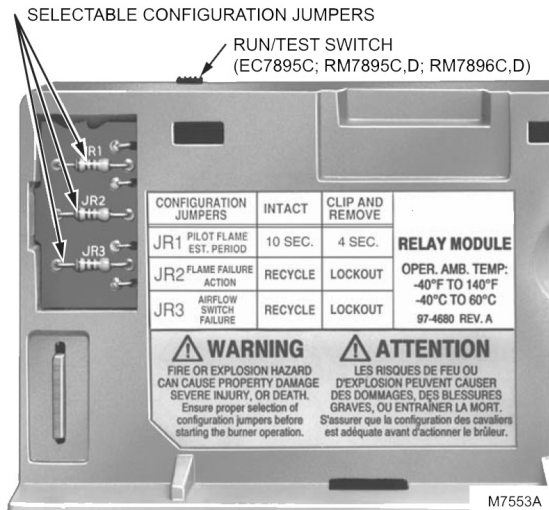
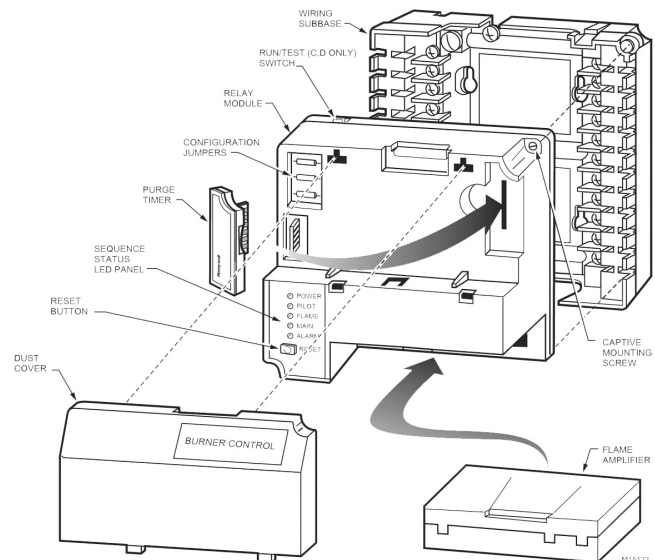
**Figure 17. Selectable site-configurable jumpers**

**Figure 18. Relay module plug-in diagram**

## Settings and Adjustments

The relay module has three site-configurable jumper options.

**Table 7. Jumper options**

Jumper #	Description	Intact	Clipped
JR1	Pilot Flame Establishing Period (PFEP)	10 seconds	4 seconds
JR2	Flame Failure Action	Recycle	Lockout
JR3	Airflow Switch (1LK) Failure	Recycle	Lockout

If necessary, clip the site-configurable jumpers with side cutters and remove the resistors from the relay module.

### Notes:

- Clipping and removing a site-configurable jumper enhances the level of safety.
- Clipping and removing a jumper after 200 hours of operation causes a non-resettable fault 100. The relay module must then be replaced.

**⚠ WARNING**

**Combustible Materials!**

Failure to maintain proper clearance between the unit heat exchanger, vent surfaces and combustible materials could cause a fire which could result in death or serious injury or property damage. Refer to unit nameplate and installation instructions for proper clearances.

**⚠ AVERTISSEMENT**

**Matériaux combustibles!**

Tout manquement à l'obligation de maintenir une distance appropriée entre l'échangeur de chaleur de l'unité, les surfaces de ventilation et les matériaux combustibles peut provoquer un incendie pouvant résulter en des blessures corporelles graves, voire mortelles, ou des dommages matériels. Reportez-vous à la plaque signalétique de l'unité et aux instructions d'installation pour connaître les distances appropriées.

## Operation of the Direct Spark Ignition Control Gas Valve

On a call for heat, a 30-second pre-purge is initiated. Upon completion of the pre-purge, the gas valve and 60 Hz spark are energized. When flame is detected, the control enters the steady state heating condition. Steady state heating will continue until the call for heat is satisfied.

If ignition is not achieved within 10 seconds, the control valve shuts off the gas and locks out. If the trial for ignition has been accomplished without ignition, the control shuts off all outputs and enters lockout. Reset is accomplished by cycling the power off for a minimum of 5 seconds.



## Start-Up

If flame is lost once it has been established, the control will shut off the gas valve within 0.8 seconds and locks out.

If flame is sensed during a purge period when no flame should be present, the control will remain in a purge with the gas valve off until the false flame disappears.

If the gas valve is found to be powered when it should be off, or not powered when it should be on, the control will enter lockout with all outputs off. Reset is accomplished by cycling the power off for a minimum of 5 seconds.

- **High Fire Test Following Normal Burner Starting Sequence**

- At ROD override, Heating Control Signal to 100 percent.
- When pressure at PG2 stabilizes, confirm PG1 and PG2 pressures are within  $\pm 5$  percent of the pressures shown on Burner Data Plate.

### WARNING

#### **Hazard of Explosion!**

Failed gas components could explode or leak flammable gas which could cause a fire resulting in death or serious injury or property damage. To avoid damage to unit if PG1 or PG2 exceed data plate pressures +5 percent, disable incoming gas using the manual shutoff valves and ensure incoming pressure is within nameplate data BEFORE enabling the gas.

### WARNING

#### **Risque d'explosion!**

Des composants au gaz défectueux peuvent exploser ou entraîner des fuites de gaz inflammable pouvant provoquer un incendie résultant en des blessures graves, voire mortelles, ou des dommages matériels. Pour éviter d'endommager l'unité si PG1 ou PG2 dépasse les pressions nominales indiquées sur la plaque signalétique de plus de 5 %, désactivez l'arrivée en gaz au moyen des vannes d'arrêt manuel et assurez-vous que la pression entrante est conforme aux valeurs indiquées sur la plaque signalétique AVANT d'activer l'arrivée en gaz.

- Record Gas Pressures
  - PG1
  - PG2
- At ROD, read and record
  - Outdoor Air Temperature
  - Discharge Air Temperature
  - Burner  $\Delta P$
- Release Heating Control Signal Override
- **Low Fire Test Following Normal Burner Starting Sequence**
  - Override Heating Control Signal to 0 percent

- Confirm PG1 and PG2 pressures are within  $\pm 5$  percent of the pressures shown on Burner Data Plate
- Allow a minimum of 5 minutes of operation at 0 percent heating signal
- At ROD read and record
  - Outdoor Air Temperature
  - Discharge Air Temperature
  - Burner  $\Delta P$
- Record Gas Pressures
  - PG1
  - PG2
- **Ignition Cycle Test**
  - Release Heating Control Signal Override
  - Complete at least (5) calls for heat
    - At each call for heat default heating start-up, signal is 25 percent
    - Following each ignition test and before attempting the next test monitor, analogue Heating Control Signal at ROD to be sure heat signal is released at end of each 90-second warm-up period



# Maintenance

Make sure all personnel are standing clear of the unit before proceeding. The system components will start when the power is applied.

## Monthly Maintenance

Before completing the following checks, turn the unit OFF and lock the main power disconnect switch open.

### ⚠ WARNING

#### Hazardous Voltage!

Failure to disconnect power before servicing could result in death or serious injury. Disconnect all electric power, including remote disconnects before servicing. Follow proper lockout/tagout procedures to ensure the power can not be inadvertently energized.

### ⚠ AVERTISSEMENT

#### Risque d'électrocution!

Le non-respect de cette consigne peut entraîner des blessures graves, voire mortelles. Avant toute intervention, coupez l'alimentation électrique, y compris aux sectionneurs à distance. Suivez scrupuleusement les procédures de verrouillage/mise hors service préconisées pour empêcher tout rétablissement accidentel de l'alimentation électrique.

## Filters

Inspect the return air filters. Clean or replace them if necessary. Refer to the unit Service Facts for filter information.

## Supply/Return Air Smoke Detector Maintenance

Airflow through the unit is affected by the amount of dirt and debris accumulated on the indoor coil and filters.

To insure that airflow through the unit is adequate for proper sampling by the return air smoke detector, complete adherence to the maintenance procedures, including recommended intervals between filter changes, and coil cleaning is required.

Periodic checks and maintenance procedures must be performed on the smoke detector to insure that it will function properly.

For detailed instructions concerning these checks and procedures, refer to the appropriate section(s) of the smoke detector Installation and Maintenance Instructions provided with the literature package for this unit.

## Cooling Season

- Check the unit's drain pans and condensate piping to ensure that there are no blockages.

- Inspect the evaporator and condenser coils for dirt, bent fins, etc. If the coils appear dirty, clean them according to the instructions described in ["Condenser Coil Cleaning," p. 47.](#)
- Manually rotate the condenser fan(s) to ensure free movement and check motor bearings for wear. Verify that all of the fan mounting hardware is tight.
- Inspect the F/A-R/A damper hinges and pins to ensure that all moving parts are securely mounted. Keep the blades clean as necessary.
- Verify that all damper linkages move freely; lubricate with white grease, if necessary.
- Check supply fan motor bearings; repair or replace the motor as necessary.
- Check the fan shaft bearings for wear. Replace the bearings as necessary.
- Verify that all wire terminal connections are tight.
- Remove any corrosion present on the exterior surfaces of the unit and repaint these areas.
- Generally inspect the unit for unusual conditions (e.g., loose access panels, leaking piping connections, etc.).
- Make sure that all retaining screws are reinstalled in the unit access panels once these checks are complete.
- With the unit running, check and record the: ambient temperature; compressor suction and discharge pressures; superheat; Record this data on an "operator's maintenance log" like the one shown in [Table 11, p. 54.](#) If the operating pressures indicate a refrigerant shortage, measure the system superheat.

**Note:** Do NOT release refrigerant to the atmosphere! If adding or removing refrigerant is required, the service technician must comply with all federal, state and local laws.

## Heating Season

- Inspect the unit's air filters. If necessary, clean or replace them.
- Check supply fan motor bearings; repair or replace the motor as necessary.
- Inspect both the main unit control panel and heat section control box for loose electrical components and terminal connections, as well as damaged wire insulation. Make any necessary repairs.
- Refer to ["Heater Maintenance," p. 52](#) and ["Inspection and Maintenance of Gas Ports," p. 53.](#)

## Condenser Coil Cleaning

Regular coil maintenance, including annual cleaning, enhances the unit's operating efficiency by minimizing: compressor head pressure and amperage draw; evaporator water carryover; fan brake horsepower, due to increase static pressure losses; airflow reduction.



## Maintenance

At least once each year, or more often if the unit is located in a “dirty” environment, clean the condenser coils using the instructions outlined below. Be sure to follow these instructions as closely as possible to avoid damaging the coils.

### Round Tube Plate Fin (RTPF) Coils

To clean refrigerant coils, use a soft brush and a sprayer (either a garden pump-up type or a high-pressure sprayer). A high-quality detergent is also required; suggested brands include “SPREX A.C.”, “OAKITE 161”, “OAKITE 166” and “COILOX”. If the detergent selected is strongly alkaline (pH value exceeds 8.5), add an inhibitor.

#### ⚠ WARNING

##### Hazardous Chemicals!

Failure to follow all safety instructions below could result in death or serious injury. Coil cleaning agents can be either acidic or highly alkaline and can burn severely if contact with skin occurs. Handle chemical carefully and avoid contact with skin. ALWAYS wear Personal Protective Equipment (PPE) including goggles or face shield, chemical resistant gloves, boots, apron or suit as required. For personal safety refer to the cleaning agent manufacturer’s Materials Safety Data Sheet and follow all recommended safe handling practices.

#### ⚠ AVERTISSEMENT

##### Produits chimiques dangereux!

Le non-respect de toutes les consignes de sécurité indiquées ci-après pourrait entraîner des blessures graves voire mortelles. Les agents de nettoyage pour serpentins peuvent être soit acides, soit fortement alcalins et peuvent entraîner des brûlures graves au contact de la peau. Manipulez les produits chimiques avec prudence et évitez tout contact avec la peau. Portez TOUJOURS un équipement de protection individuel (EPI), y compris des lunettes ou un masque facial, des gants résistant aux produits chimiques, des bottes, un tablier ou une combinaison conformément aux exigences. Pour la sécurité personnelle, voir les fiches de données de sécurité du fabricant pour l’agent de nettoyage et suivre toutes les pratiques de manipulation préconisées.

1. Remove enough panels from the unit to gain access to the coil.
2. Protect all electrical devices such as motors and controllers from any over spray.
3. Straighten any bent coil fins with a fin comb.

#### ⚠ WARNING

##### Hazardous Pressures!

Failure to follow safety precautions below could result in coil bursting, which could result in death or serious injury. Coils contain refrigerant under pressure. When cleaning coils, maintain coil cleaning solution temperature under 150°F to avoid excessive pressure in the coil.

#### ⚠ AVERTISSEMENT

##### Pressions dangereuses!

Tout manquement aux consignes de sécurité préconisées ci-dessous risquerait d’entraîner un éclatement du serpentins susceptible de provoquer des blessures graves voire mortelles. Les serpentins contiennent du fluide frigorigène sous pression. Lors du nettoyage des serpentins, maintenez la température de l’agent de nettoyage pour serpentins à moins de 65,5 °C (150 °F) pour éviter toute pression excessive dans le serpentins..

4. Mix the detergent with water according to the manufacturer’s instructions. If desired, heat the solution BUT DO NOT EXCEED 150°F maximum to improve its cleansing capability.
5. Pour the cleaning solution into the sprayer. If a high-pressure sprayer is used:
  - a. do not allow sprayer pressure to exceed 600 psi.
  - b. the minimum nozzle spray angle is 15°.
  - c. maintain a minimum clearance of 6 in. between the sprayer nozzle and the coil.
  - d. spray the solution perpendicular (at 90°) to the coil face.
6. Spray the leaving-airflow side of the coil first; then spray the opposite side of the coil. Allow the cleaning solution to stand on the coil for five minutes.
7. Rinse both sides of the coil with cool, clean water.
8. Inspect both sides of the coil; if it still appears to be dirty, repeat [Step 6](#) and [Step 7](#).
9. Reinstall all of the components and panels removed in [Step 1](#) and any protective covers installed in [Step 2](#).

## Direct-Fired Unit Maintenance Schedule

Periodic maintenance is essential to the efficient operation and extended service life of the direct fired equipment. Failure to provide maintenance as recommended may void the equipment warranty.



**⚠ WARNING****Hazardous Service Procedures!**

Failure to follow all precautions in this manual and on the tags, stickers, and labels could result in death or serious injury.

Technicians, in order to protect themselves from potential electrical, mechanical, and chemical hazards, **MUST** follow precautions in this manual and on the tags, stickers, and labels, as well as the following instructions: Unless specified otherwise, disconnect all electrical power including remote disconnect and discharge all energy storing devices such as capacitors before servicing. Follow proper lockout/tagout procedures to ensure the power can not be inadvertently energized. When necessary to work with live electrical components, have a qualified licensed electrician or other individual who has been trained in handling live electrical components perform these tasks.

**⚠ AVERTISSEMENT****Procédures d'entretien dangereuses!**

Le non-respect de toutes les précautions contenues dans ce manuel ainsi que sur les étiquettes et les autocollants peut entraîner des blessures graves voire mortelles.

Les techniciens, afin d'être protégés des éventuels risques électriques, mécaniques et chimiques, **DOIVENT** suivre les précautions contenues dans ce manuel, sur les étiquettes et les autocollants, ainsi que les instructions suivantes : Sauf indication contraire, coupez toute l'alimentation électrique y compris les disjoncteurs à distance et déchargez tous les dispositifs de stockage d'énergie comme les condensateurs avant l'entretien. Respectez les procédures de verrouillage et d'étiquetage appropriées pour éviter tout risque de remise sous tension accidentelle. S'il est nécessaire de travailler avec des composants électriques sous tension, demandez à un électricien qualifié et agréé ou à une autre personne ayant la formation nécessaire pour manipuler des composants électriques sous tension d'exécuter ces tâches..

**⚠ WARNING****Hazardous Gases and Flammable Vapors!**

Failure to observe following instructions could result in death or serious injury. Exposure to hazardous gases from fuel substances have been shown to cause cancer, birth defects or other reproductive harm. Improper installation, adjustment, alteration, service or use of this product could cause flammable mixtures or lead to excessive carbon monoxide. To avoid hazardous gases and flammable vapors follow proper installation and set up of this product and all warnings as provided in this manual.

**⚠ AVERTISSEMENT****Vapeurs inflammables et gaz dangereux!**

Le non-respect des instructions suivantes peut être à l'origine de blessures graves, voire mortelles. L'exposition à des gaz dangereux provenant de substances combustibles est reconnue comme pouvant causer le cancer, des anomalies congénitales ou d'autres effets néfastes sur la reproduction. Des erreurs dans l'installation, le réglage, les modifications, les réparations ou la maintenance de ce produit peuvent entraîner des mélanges inflammables ou la libération excessive de monoxyde de carbone. Pour éviter des vapeurs inflammables et gaz dangereux, installez et mettez ce produits en service de manière appropriée et respectez tous les avertissements indiqués dans le présent manuel.

1. After 8 hours of operation:
  - a. Check that the fan belts are tight and sheaves are aligned. The fan belts should be checked every 30 days after the first 60 days of new belt run-in.
  - b. Check set-screws and bolts on the fan, bearings, and burner assembly.

**NOTICE****Belt Over-Tension!**

Over-tensioning the belt could result in equipment damage as it reduces fan and motor bearing life, accelerates belt wear, and can cause shaft failure.

2. Monthly:
  - a. Check all valves, piping and connections for leaks.
  - b. Check the flame setting.
  - c. Check the fuel pressure in the fuel supply line to each heater.
  - d. Check the burner manifold pressure at full fire.
  - e. Clean the flame sensor(s) or UV sight tube(s).
  - f. Inspect filters. Clean or replace as necessary.
  - g. Inspect the main fan bearings.
  - h. Check all dampers, damper actuators and linkages. Adjust and tighten if necessary.
  - i. Ensure that there are no obstruction blocking the air supply to the heater or the air discharge from the heater.
  - j. Inspect the area and make sure that no combustible or hazardous material has been stored within the clearances as shown on the unit nameplate.
3. Quarterly:
  - a. Complete the monthly maintenance schedule.
  - b. Check the belt tension for the main fan(s) and adjust if necessary.
  - c. Check the alignment of the sheaves and adjust if necessary.



- d. Inspect all bearings, set-screws for tightness and lubricate bearings if necessary.
  - e. Check the pilot electrical system. Adjust if necessary.
  - f. Check the pilot assembly. Clean and adjust if necessary.
  - g. Inspect the burner carefully. clean and adjust if necessary.
  - h. Check voltages and amp draw on main fan motor.
  - i. Check the operation of all safety controls individually.
  - j. Check the operation of the automatic gas shut-off valves and check them for leakage at the pressure test ports provided.
  - k. On vertical units, inspect burner drip leg and drain if necessary.
4. Off-Season/Yearly:
- a. Complete the monthly and quarterly maintenance schedule.
  - b. Inspect all fan wheels and housings. Clean if necessary.
  - c. Check that all fan wheels and sheaves are securely set on the shaft.
  - d. Inspect all bearings and alignment. Adjust if necessary.
  - e. Inspect all V-belts. Replace if necessary.
  - f. Inspect all electrical components, connections, and terminals. Clean and tighten where necessary.
  - g. Test ignition spark. Adjust gap if necessary.
  - h. Clean ignition electrodes and check for cracks.
  - i. Test flame safeguard relay and replace components if necessary.
  - j. Inspect all regulators, relief valves, motorized valves, solenoid valves, vent valves, manual shut-off valves and safety shut-off valves. Check their operation and clean as necessary.
  - k. Ensure all vents to the atmosphere are clean and free from obstruction.
  - l. Inspect and clean all drip legs in the fuel line.
  - m. Lubricate fan motor as directed by motor manufacturer.
  - n. Inspect fan motor wiring for loose connections.
  - o. Lightly oil all door latches.
  - p. Check that the cabinet is weather-tight. Replace door gaskets and re-caulk as necessary.

**Note:** *It is important to keep screened air intakes clear of obstructions at all times.*

## Lubrication Requirements

Some blower motors require lubrication while others do not. Those that require lubrication can be identified by the presence of grease plugs in the motor casing at each end. Motors that do not have grease plugs cannot be greased and are lubricated for the life of the motor bearing.

**Table 8. Lubrication instructions**

Item	Manufacturer	Bearing Type
All 3-PH Fan Motors (1 HP to 100 HP) ODP, TEFC	U.S., Baldor™ or Equal	Single Row Ball Bearings
All 1-PH Motors (Fractional HP) ODP, TEFC or TEAO	Century™, G.E.™, or Equal	Bronze Sleeve Bearings
Fractional HP 1-PH ODP or TEFC	Century, G.E., or Equal	Bronze Sleeve Bearings
Fan Shaft Bearings	Fafnir or Equal	Self-aligning, Single Row or Double Row Ball Bearings, Resilient Mounted
Dampers	Applied Air™ or Equal	Sleeve

Lubrication of motors should be done while the motor is warm and at a standstill. Remove and clean all grease plugs and insert a grease fitting in the upper hole in the motor casing at each end (viewed as if motor were sitting horizontally on its base). There may be one or two plugs in each end casing of the motor. Add a small amount of a clean, good grade ball bearing grease (such as Exxon® Polyrex™ EM or equal, with a low pressure grease gun. Run the motor five minutes before removing the grease fittings and replacing the plugs.

### NOTICE

#### Bearing Overheating!

**Excess grease could result in overheating the bearings which could result in equipment damage.**

**Note:** *On totally enclosed fan cooled (TEFC) motors, the rear end fan housing must be removed to expose the grease plugs.*

## Pillow Block Bearings

Pillow block bearings are used on supply blower(s). Bearings have been pre-lubricated with a number 2 lithium based grease. Re-lubrication should be done with a similar grease using a low pressure grease gun. Wipe all grease fittings clean before adding grease. Grease should be added slowly, in small amounts at frequent intervals while the shaft is being manually rotated.

A slight showing of grease at the seals with accompanying normal bearing temperature indicates proper lubrication. Normal temperature can range from “cool” to “hot to the touch” depending on size, speed and surrounding conditions. Excessive bearing temperature indicates faulty lubrication. An insufficient amount of grease is suggested by a bearing showing no grease at the seals, and a higher than normal temperature and noise level. Excessive leakage of grease at the seals, and a high operating temperature suggest too much grease.

**Important:** *Grease twin blower inner bearing on same schedule as two outer bearings.*

## Frequency of Lubrication

Frequency of lubrication depends upon operating conditions. The bearing operating temperature is the best index for determining a re-lubrication schedule. [Table 9](#) gives the frequency of re-lubrication based upon continuous operation for various operating temperatures and can be used as a satisfactory guide for determining when all ball and roller bearings should be lubricated.

**Table 9. Frequency of lubrication**

Speed (rpm)	Temp. (°F)	Cleanliness	Interval
100	Up to 125	Clean	6 Months
500	Up to 150	Clean	2 Months
1000	Up to 210	Clean	2 Weeks
1500	Over 150	Clean	Weekly
Any Speed	Up to 150	Dirty	1 Week
Any Speed	Over 150	Dirty	Daily to 1 Week
Any Speed	Any Temp.	Very Dirty	Daily to 1 Week
Any Speed	Any Temp.	Extreme Conditions	Daily to 1 Week

## Dampers

Dampers should be inspected monthly (daily in icy weather) for securely fastened linkages, and smooth operation. If dampers are binding or excessively noisy, then lubrication may be required. Place one drop of #20 weight machine oil on each blade bearing, and linkage ball joint. Do not over lubricate, and wipe any excess from the area. Ensure to note that dampers over 49 inches long have intermediate bearings which require lubrication.

## Air Filters

### **⚠ WARNING**

#### **Hazardous Voltage!**

**Failure to disconnect power before servicing could result in death or serious injury. Disconnect all electric power, including remote disconnects before servicing. Follow proper lockout/tagout procedures to ensure the power can not be inadvertently energized.**

### **⚠ AVERTISSEMENT**

#### **Risque d'électrocution!**

**Le non-respect de cette consigne peut entraîner des blessures graves, voire mortelles. Avant toute intervention, coupez l'alimentation électrique, y compris aux sectionneurs à distance. Suivez scrupuleusement les procédures de verrouillage/mise hors service préconisées pour empêcher tout rétablissement accidentel de l'alimentation électrique.**

All filter banks should be equipped with a manometer or differential pressure switch to indicate when the filters are dirty. Filters should be replaced when the differential pressure

across them reaches the manufacturer's recommended final value. Dirty filter elements should be replaced with a clean element of the same type and size. In addition, it is strongly advised that the air filters be checked every 30 days and replaced with new filters (throw-away type) or cleaned (washable type) as required. Cleanable filters should be given new application of filter coating after washing to maintain optimum performance.

## Belt Tensions and Adjustments

Belt tension is adjusted during the initial run-in and test periods at the factory. However, belts are run as slack as possible to prevent excessive damage to the bearings, yet tight enough to prevent slippage.

If necessary, tighten all belts during the first few months of operation, and verify proper tension weekly during the first 60 days, after which, 30-day check intervals are sufficient.

### **NOTICE**

#### **Motor Failure!**

**Tightening any belt or belts by changing the pitch of an adjustable pulley will change the speed of a driven pulley. This could cause the unit to be rendered out of air balance which could result in improper unit operation or motor failure could result.**

## Suggested Belt Tension Method

1. Check tension frequently during the first 24 to 48-hours of run-in operation. Ideal tension is the lowest tension at which the belt will not slip under peak load conditions. Over tensioning shortens belt and bearing life.
2. To properly tension a conventional V-belt drive, use the following method:
  - a. Measure the span length.
  - b. At the center of the span, apply a force perpendicular to the span to deflect the belt 1/64 inch for every inch of span length. For example: for a 40-inch span, apply a force that will deflect the belt 40/64 in. or 5/8 in.
  - c. Compare the force applied with the values given in [Table 10](#). If the force is between the values for normal tension and 1-1/2 times normal tension, the belt tension should be satisfactory. If the belt tension is not within this range, it can be adjusted by loosening the motor mounting bolts and adjusting the position of the motor along its base.

**Note:** *A new drive can be tightened to two times the minimum value shown to allow for normal drop in tension during the run-in period.*

**Table 10. Belt tension specifications**

Small pulley diameter range (in.)	3.4–4.2	4.4–4.6	5.8–8.6
Belt manufacturer and belt type	Gates Hi-Power		
Pounds of force for normal tension	4.4	4.9	5.8
Pounds of force for 1-1/2 times normal tension	6.6	7.4	8.7

**Note:** For recommendations of other belt types, consult respective manufacturers.

## Gaskets

Gaskets are used on doors, inspection covers, some filter racks and some outdoor air dampers. Inspect gaskets periodically and repair or replace as required.

### ⚠ WARNING

#### Check Gas Tightness of Safety Shut-Off Valves Annually!

Gas tightness of the safety shut-off valves must be checked at least on an annual basis. Failure to ensure gas tightness of the safety shut-off valves could result in an explosion which could result in death or serious injury.

### ⚠ AVERTISSEMENT

#### Vérifiez l'étanchéité au gaz des vannes d'arrêt de sécurité tous les ans!

L'étanchéité au gaz des vannes d'arrêt de sécurité doit être vérifiée au moins une fois par an. Le non-respect de l'obligation de garantir l'étanchéité des vannes d'arrêt de sécurité peut entraîner une explosion pouvant résulter en des blessures graves, voire mortelles.

## Annual Maintenance

1. Inspect the tightness of the gas safety shut-off valves for the furnace by turning off the manual valve upstream of the appliance combination control.
2. Remove the 1/8 in. pipe plug on the inlet side of the combination control and connect a manometer to the tapping.
3. Turn the manual valve ON to apply pressure to the combination control.
4. Record the pressure reading on the manometer, then turn the valve OFF.

A loss of pressure indicates a leak. If a leak is detected, use a soap solution to check all threaded connections. If no leak is found, the combination control may be faulty and must be replaced before placing the appliance back in service.

## Heater Maintenance

At least a yearly inspection is recommended for heating installations and more frequently for process applications in year-round operation. Experience is the best guide in

determining frequency of inspection, but as a minimum, the following procedure should be followed.

### ⚠ WARNING

#### Hazardous Voltage!

Failure to disconnect power before servicing could result in death or serious injury. Disconnect all electric power, including remote disconnects before servicing. Follow proper lockout/tagout procedures to ensure the power can not be inadvertently energized.

### ⚠ AVERTISSEMENT

#### Risque d'électrocution!

Le non-respect de cette consigne peut entraîner des blessures graves, voire mortelles. Avant toute intervention, coupez l'alimentation électrique, y compris aux sectionneurs à distance. Suivez scrupuleusement les procédures de verrouillage/mise hors service préconisées pour empêcher tout rétablissement accidentel de l'alimentation électrique.

### ⚠ WARNING

#### Combustible Materials!

Failure to maintain proper clearance between the unit heat exchanger, vent surfaces and combustible materials could cause a fire which could result in death or serious injury or property damage. Refer to unit nameplate and installation instructions for proper clearances.

### ⚠ AVERTISSEMENT

#### Matériaux combustibles!

Tout manquement à l'obligation de maintenir une distance appropriée entre l'échangeur de chaleur de l'unité, les surfaces de ventilation et les matériaux combustibles peut provoquer un incendie pouvant résulter en des blessures corporelles graves, voire mortelles, ou des dommages matériels. Reportez-vous à la plaque signalétique de l'unité et aux instructions d'installation pour connaître les distances appropriées.

1. Shut the system down totally, disconnecting or locking out power supply.
2. Inspect the burner carefully, including upstream and downstream sides of mixing plates as well as burner body face.

**Note:** The complete burner assembly may have to be removed for proper inspection and cleaning. Any accumulation of scale or foreign material on either side of the mixing plates should be removed with a wire brush. Visually check that no holes in the mixing plates are blocked. If burner ports are plugged (even partially) clear with a piece of wire. See maintenance of gas ports.

### NOTICE

#### Equipment Performance!

Do not enlarge burner ports; doing so could adversely affect equipment performance.

- If any mixing plates are loose or missing fasteners, tighten/replace as necessary. Always use zinc plated or stainless fasteners

**Note:** *The missing plates on the burner may display hairline cracks. These cracks are normal and caused by thermal stresses occurring during combustion. The presence of these hairline cracks in no significant way affects the combustion efficiency or performance of the heater. Should a large opening develop, the specific mixing plate or plates must be replaced. Otherwise, it may cause difficulties in cross ignition of flame across the face of the burner.*

- Place the system back into operation and view burner while cycling through full firing range. This will give a visual check for blocked burner spots.
- Inspect the flame rod and ignition electrode for dirt and moisture. Wipe off if necessary. Examine for any evidence of premature arcing. If in doubt, check continuity of flame rod to be sure it is not grounding out. Replace if required.
- The porcelain on the ignition electrode must be intact (not cracked). The spark gap should be 1/8 in.
- Replace all access panels which have been removed and operate the unit for a test period.
- Check for normal response and function of all controls.
- Check all gas piping for possible leaks using a soap bubble solution.

### WARNING

#### Hazardous Gases and Flammable Vapors!

Failure to observe following instructions could result in death or serious injury. Exposure to hazardous gases from fuel substances have been shown to cause cancer, birth defects or other reproductive harm. Improper installation, adjustment, alteration, service or use of this product could cause flammable mixtures or lead to excessive carbon monoxide. To avoid hazardous gases and flammable vapors follow proper installation and set up of this product and all warnings as provided in this manual.

### AVERTISSEMENT

#### Vapeurs inflammables et gaz dangereux!

Le non-respect des instructions suivantes peut être à l'origine de blessures graves, voire mortelles. L'exposition à des gaz dangereux provenant de substances combustibles est reconnue comme pouvant causer le cancer, des anomalies congénitales ou d'autres effets néfastes sur la reproduction. Des erreurs dans l'installation, le réglage, les modifications, les réparations ou la maintenance de ce produit peuvent entraîner des mélanges inflammables ou la libération excessive de monoxyde de carbone. Pour éviter des vapeurs inflammables et gaz dangereux, installez et mettez ce produits en service de manière appropriée et respectez tous les avertissements indiqués dans le présent manuel..

- Inspect the support means to be sure that everything is firmly anchored in-place.

#### Inspection and Maintenance of Gas Ports

Conduct initial inspection within the first month after commissioning. Visually check the gas ports of the new burner assemblies for any piping scale or debris. Use pin vise with drill bit to remove.

**Figure 19. Gas port inspection**

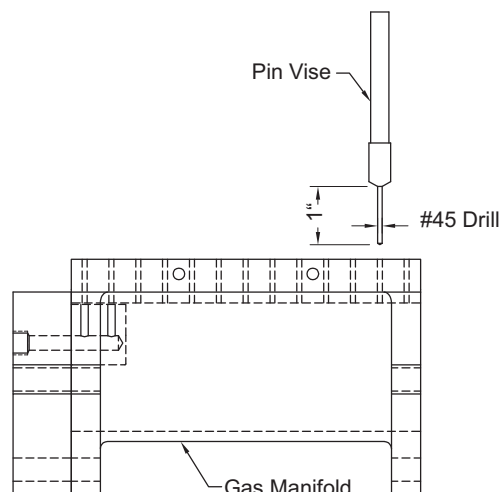

Annual inspections are normally adequate once the initial debris is removed. The operating conditions of the burner will determine how frequently maintenance is actually required. Use of an electric drill motor is not recommended unless both pin vise and drill (see [Figure 19](#)) can be chucked-up in a variable-speed drill unit. Care should be given in this instance due to the nature of drill bits and their ability to easily snap off in a port when using a drill motor. Removal of broken bits from the gas port is difficult.

Alternate drill sizes to be used are 5/64 in. (for #47) and 1/16 in. (for #50).



**Maintenance**

**Final Process**

For future reference, you may find it helpful to record the unit data requested below in the blanks provided.

(1) Complete Unit Model Number:

\_\_\_\_\_

\_\_\_\_\_

\_\_\_\_\_

(2) Unit Serial Number:

\_\_\_\_\_

\_\_\_\_\_

\_\_\_\_\_

(3) Wiring Diagram Numbers (from unit control panel)

— schematic(s)

\_\_\_\_\_

\_\_\_\_\_

\_\_\_\_\_

\_\_\_\_\_

— connection(s)

\_\_\_\_\_

\_\_\_\_\_

\_\_\_\_\_

**Table 11. Sample maintenance log**

Date	Current Ambient Temp F/C	Refrigerant Circuit #1						Refrigerant Circuit #2					
		Compr. Oil Level	Suct. Press. Psig/kPa	Disch. Press. Psig/kPa	Liquid Press. Psig/kPa	Super-heat F/C	Sub-cool F/C	Compr. Oil Level	Suct. Press. Psig/kPa	Disch. Press. Psig/kPa	Liquid Press. Psig/kPa	Super-heat F/C	Sub-cool F/C
		- ok - low						- ok - low					
		- ok - low						- ok - low					
		- ok - low						- ok - low					
		- ok - low						- ok - low					
		- ok - low						- ok - low					
		- ok - low						- ok - low					
		- ok - low						- ok - low					
		- ok - low						- ok - low					
		- ok - low						- ok - low					
		- ok - low						- ok - low					
		- ok - low						- ok - low					
		- ok - low						- ok - low					
		- ok - low						- ok - low					
		- ok - low						- ok - low					
		- ok - low						- ok - low					



# Performance Data

**Table 12. OABD general data—Cooling 3 to 5 tons high efficiency**

	3 Tons	4 Tons	5 Tons
	OABD036A	OABD048A	OABD060A
<b>Cooling Performance</b>			
Gross Cooling Capacity, Btu (kW)	41,462 (12.15)	55,709 (16.33)	66,870 (19.60)
Nominal cfm (m <sup>3</sup> /h)	500–2000 (850–3398)	500–2000 (850–3398)	500–2000 (850–3398)
<b>Compressor</b>			
Number	1	1	1
Type	Scroll	Scroll	Scroll
<b>Outdoor Coil</b>			
Type	High Performance	High Performance	High Performance
Tube Size—OD, in. (mm)	3/8 (9.5)	3/8 (9.5)	3/8 (9.5)
Face Area, ft <sup>2</sup> (m <sup>2</sup> )	11 (1.02)	11 (1.02)	11 (1.02)
Rows	2	2	2
FPI	14	14	14
<b>Indoor Coil</b>			
Type	Propeller	Propeller	Propeller
Tube Size—OD, in. (mm)	1/2 (12.7)	1/2 (12.7)	1/2 (12.7)
Face Area, ft <sup>2</sup> (m <sup>2</sup> )	4.17 (0.39)	4.17 (0.39)	4.17 (0.39)
Rows	4	4	4
FPI	12	12	12
Refrigerant Control	TXV	TXV	TXV
Drain Connection Size, in. (mm)	3/4 (20)	3/4 (20)	3/4 (20)
<b>Outdoor Fan</b>			
Type	Propeller	Propeller	Propeller
Number Used	1	1	1
Diameter, in. (mm)	27	27	27
Drive Type	Direct	Direct	Direct
No. Speeds	1	1	1
CFM (m <sup>3</sup> /h)	7,000 (11,893)	7,000 (11,893)	7,000 (11,893)
Number Motors	1	1	1
Motor HP (kW), per motor	1.0 (0.75)	1.0 (0.75)	1.0 (0.75)
Motor RPM	1140	1140	1140
<b>Indoor Fan</b>			
Type	Backward Curved	Backward Curved	Backward Curved
Number Used	1	1	1
Diameter	Varies	Varies	Varies
Drive Type	Direct Drive	Direct Drive	Direct Drive
Number Motors	1	1	1
Motor HP (kW), Standard–Oversized	2.68–4.0 (2–3)	2.68–4.0 (2–3)	2.68–4.0 (2–3)
Motor RPM	Varies	Varies	Varies
<b>Filters</b>			
Type Furnished	Varies	Varies	Varies
Evap Size, in. (Qty)	20 x 24 x 2 (2)	20 x 24 x 2 (2)	20 x 24 x 2 (2)
Type Furnished	MERV-8	MERV-8	MERV-8
ERV Size, in. (Qty)	20 x 24 x 2 (4)	20 x 24 x 2 (4)	20 x 24 x 2 (4)
<b>Refrigerant Charge, lb of R-410A</b>	See Nameplate	See Nameplate	See Nameplate



## Performance Data

**Table 13. OABD general data—Cooling 6 to 9 tons high efficiency**

	6 Tons	7 Tons	8 Tons	9 Tons
	OABD072A	OABD084A	OABD096A	OABD108A
<b>Cooling Performance</b>				
Gross Cooling Capacity, Btu (kW)	78,600 (23.04)	88,768 (26.02)	99,099 (29.04)	108,214 (31.71)
Nominal cfm (m <sup>3</sup> /h)	625–3000 (1061–5097)	625–3000 (1061–5097)	625–3000 (1061–5097)	625–3000 (1061–5097)
<b>Compressor</b>				
Number	1	1	1	1
Type	Scroll	Scroll	Scroll	Scroll
<b>Outdoor Coil</b>				
Type	High Performance	High Performance	High Performance	High Performance
Tube Size—OD, in. (mm)	3/8 (9.5)	3/8 (9.5)	3/8 (9.5)	3/8 (9.5)
Face Area, ft <sup>2</sup> (m <sup>2</sup> )	11 (1.02)	11 (1.02)	11 (1.02)	11 (1.02)
Rows	2	2	2	2
FPI	14	14	14	14
<b>Indoor Coil</b>				
Type	High Performance	High Performance	High Performance	High Performance
Tube Size—OD, in. (mm)	3/8 (12.7)	1/2 (12.7)	1/2 (12.7)	1/2 (12.7)
Face Area, ft <sup>2</sup> (m <sup>2</sup> )	6.56 (167) 5.69 (145)	6.56 (167) 5.69 (145)	6.56 (167) 5.69 (145)	6.56 (167) 5.69 (145)
Rows	4 6	4 6	4 6	4 6
FPI	12	12	12	12
Refrigerant Control	TXV	TXV	TXV	TXV
Drain Connection Size, in. (mm)	3/4 (20)	3/4 (20)	3/4 (20)	3/4 (20)
<b>Outdoor Fan</b>				
Type	Propeller	Propeller	Propeller	Propeller
Number Used	1	1	1	1
Diameter, in. (mm)	27	27	27	27
Drive Type	Direct	Direct	Direct	Direct
No. Speeds	1	1	1	1
CFM (m <sup>3</sup> /h)	7,000 (11,893)	7,000 (11,893)	7,000 (11,893)	7,000 (11,893)
Number Motors	1	1	1	1
Motor HP (kW), per motor	1.0 (0.75)	1.0 (0.75)	1.0 (0.75)	1.0 (0.75)
Motor RPM	1140	1140	1140	1140
<b>Indoor Fan</b>				
Type	Backward Curved	Backward Curved	Backward Curved	Backward Curved
Number Used	1	1	1	1
Diameter	Varies	Varies	Varies	Varies
Drive Type	Direct Drive	Direct Drive	Direct Drive	Direct Drive
Number Motors	1	1	1	1
Motor HP (kW), Standard–Oversized	2.68–4.0 (2–3)	2.68–4.0 (2–3)	2.68–4.0 (2–3)	2.68–4.0 (2–3)
Motor RPM	Varies	Varies	Varies	Varies
<b>Filters</b>				
Type Furnished	Varies	Varies	Varies	Varies
Evap Size, in. (Qty)	20 x 24 x 2 (2)	20 x 24 x 2 (2)	20 x 24 x 2 (2)	20 x 24 x 2 (2)
Type Furnished	MERV-8	MERV-8	MERV-8	MERV-8
ERV Size, in. (Qty)	20 x 24 x 2 (4)	20 x 24 x 2 (4)	20 x 24 x 2 (4)	20 x 24 x 2 (4)
<b>Refrigerant Charge, lb of R-410A</b>				
	See Nameplate	See Nameplate	See Nameplate	See Nameplate



**Table 14. OAGD general data—Cooling 10 to 17 tons high efficiency**

	10 Tons	12 Tons	15 Tons	17 Tons
	OAGD120A	OAGD144A	OAGD180A	OAGD210A
<b>Cooling Performance</b>				
Gross Cooling Capacity, Btu (kW)	150,692 (44.16)	165,990 (48.65)	206,544 (60.53)	230,212 (67.47)
<b>CFM</b>				
Nominal cfm (m <sup>3</sup> /h)	1250–2500 (2124–4248)	1500–3000 (2549–5097)	1875–3750 (3186–6371)	2125–4250 (3610–7221)
<b>Compressor</b>				
Number	2	2	2	2
Type	Scroll	Scroll	Scroll	Scroll
<b>Outdoor Coil</b>				
Type	High Performance	High Performance	High Performance	High Performance
Tube Size—OD, in. (mm)	3/8 (9.5)	3/8 (9.5)	3/8 (9.5)	3/8 (9.5)
Face Area, ft <sup>2</sup> (m <sup>2</sup> )	25 (2.32)	25 (2.32)	25 (2.32)	25 (2.32)
Rows	2	2	2	2
FPI	14	14	14	14
<b>Indoor Coil</b>				
Type	High Performance	High Performance	High Performance	High Performance
Tube Size—OD, in. (mm)	1/2 (12.7)	1/2 (12.7)	1/2 (12.7)	1/2 (12.7)
Face Area, ft <sup>2</sup> (m <sup>2</sup> )	10.0 (0.93)	10.0 (0.93)	10.0 (0.93)	12.0 (1.11)
Rows	4 6	4 6	4 6	4 6
FPI	12	12	12	12
Refrigerant Control	TXV	TXV	TXV	TXV
Drain Connection Size, in. (mm)	3/4 (19.1)	3/4 (19.1)	3/4 (19.1)	3/4 (19.1)
<b>Outdoor Fan</b>				
Type	Propeller	Propeller	Propeller	Propeller
Number Used	2	2	2	3
Diameter, in. (mm)	27 (685.8)	27 (685.8)	27 (685.8)	27 (685.8)
Drive Type	Direct	Direct	Direct	Direct
No. Speeds	1	1	1	1
CFM (m <sup>3</sup> /h)	14,000 (23,786)	14,000 (23,786)	14,000 (23,786)	21,000 (35,679)
Number Motors	2	2	2	3
Motor HP (kW), per motor	1 (0.75)	1 (0.75)	1 (0.75)	1 (0.75)
Motor RPM	1,140	1,140	1,140	1,140
<b>Indoor Fan</b>				
Type	Backward Curved	Backward Curved	Backward Curved	Backward Curved
Number Used	1–2	1–2	1–2	1–2
Diameter	Varies	Varies	Varies	Varies
Drive Type	Direct or Belt Drive	Direct or Belt Drive	Direct or Belt Drive	Direct or Belt Drive
Number Motors	1–2	1–2	1–2	1–2
Motor HP (kW), Standard–Oversized	2–12 (1.49–8.95)	2–12 (1.49–8.95)	2–12 (1.49–8.95)	2–12 (1.49–8.95)
Motor RPM, Standard–Oversized	Varies	Varies	Varies	Varies
<b>Filters</b>				
Type Furnished	Refer to OAU Filter Guide in the Appendix	Refer to OAU Filter Guide in the Appendix	Refer to OAU Filter Guide in the Appendix	Refer to OAU Filter Guide in the Appendix
Number Size Recommended	Refer to OAU Filter Guide in the Appendix	Refer to OAU Filter Guide in the Appendix	Refer to OAU Filter Guide in the Appendix	Refer to OAU Filter Guide in the Appendix
<b>Refrigerant Charge, lb of R-410A</b>				
	See Nameplate	See Nameplate	See Nameplate	See Nameplate



## Performance Data

**Table 15. OAGD general data—Cooling 20 to 30 tons high efficiency**

	20 Tons	22 Tons	25 Tons	30 Tons
	OAGD240A	OAGD264A	OAGD300A	OAGD360A
<b>Cooling Performance</b>				
Gross Cooling Capacity, Btu (kW)	286,302 (83.91)	319,026 (93.50)	368,012 (107.85)	395,596 (115.94)
<b>CFM</b>				
Nominal cfm (m <sup>3</sup> /h)	2500–5000 (4248–8495)	2750–5500 (4672–9345)	3125–6250 (5309–10619)	3750–7500 (6371–12743)
<b>Compressor</b>				
Number	2	2	2	2
Type	Scroll	Scroll	Scroll	Scroll
<b>Outdoor Coil</b>				
Type	High Performance	High Performance	High Performance	High Performance
Tube Size—OD, in. (mm)	3/8 (9.5)	3/8 (9.5)	3/8 (9.5)	3/8 (9.5)
Face Area, ft <sup>2</sup> (m <sup>2</sup> )	37 (3.44)	37 (3.44)	37 (3.44)	37 (3.44)
Rows	2	2	2	2
FPI	14	14	14	14
<b>Indoor Coil</b>				
Type	High Performance	High Performance	High Performance	High Performance
Tube Size—OD, in. (mm)	1/2 (12.7)	1/2 (12.7)	1/2 (12.7)	1/2 (12.7)
Face Area, ft <sup>2</sup> (m <sup>2</sup> )	12.0 (1.11)	12.0 (1.11)	15.0 (1.39)	15.0 (1.39)
Rows	4 6	4 6	4 6	4 6
FPI	12	12	12	12
Refrigerant Control	TXV	TXV	TXV	TXV
Drain Connection Size, in. (mm)	3/4 (19.1)	3/4 (19.1)	3/4 (19.1)	3/4 (19.1)
<b>Outdoor Fan</b>				
Type	Propeller	Propeller	Propeller	Propeller
Number Used	3	3	3	3
Diameter, in. (mm)	27 (685.8)	27 (685.8)	27 (685.8)	27 (685.8)
Drive Type	Direct	Direct	Direct	Direct
No. Speeds	1	1	1	1
CFM (m <sup>3</sup> /h)	21,000 (35,679)	21,000 (35,679)	21,000 (35,679)	21,000 (35,679)
Number Motors	3	3	3	3
Motor HP (kW), per motor	1 (0.75)	1 (0.75)	1 (0.75)	1 (0.75)
Motor RPM	1,140	1,140	1,140	1,140
<b>Indoor Fan</b>				
Type	Backward Curved	Backward Curved	Backward Curved	Backward Curved
Number Used	1–2	1–2	1–2	1–2
Diameter	Varies	Varies	Varies	Varies
Drive Type	Direct or Belt Drive	Direct or Belt Drive	Direct or Belt Drive	Direct or Belt Drive
Number Motors	1–2	1–2	1–2	1–2
Motor HP (kW), Standard–Oversized	2–12 (1.49–8.95)	2–12 (1.49–8.95)	2–12 (1.49–8.95)	2–12 (1.49–8.95)
Motor RPM, Standard–Oversized	Varies	Varies	Varies	Varies
<b>Filters</b>				
Type Furnished	Refer to OAU Filter Guide in the Aopendix	Refer to OAU Filter Guide in the Aopendix	Refer to OAU Filter Guide in the Aopendix	Refer to OAU Filter Guide in the Aopendix
Number Size Recommended	Refer to OAU Filter Guide in the Aopendix	Refer to OAU Filter Guide in the Aopendix	Refer to OAU Filter Guide in the Aopendix	Refer to OAU Filter Guide in the Aopendix
<b>Refrigerant Charge, lb of R-410A</b>	See Nameplate	See Nameplate	See Nameplate	See Nameplate

# Superheat and Refrigeration Circuit Data

Figure 20. Refrigeration diagram: single compressor without reheat

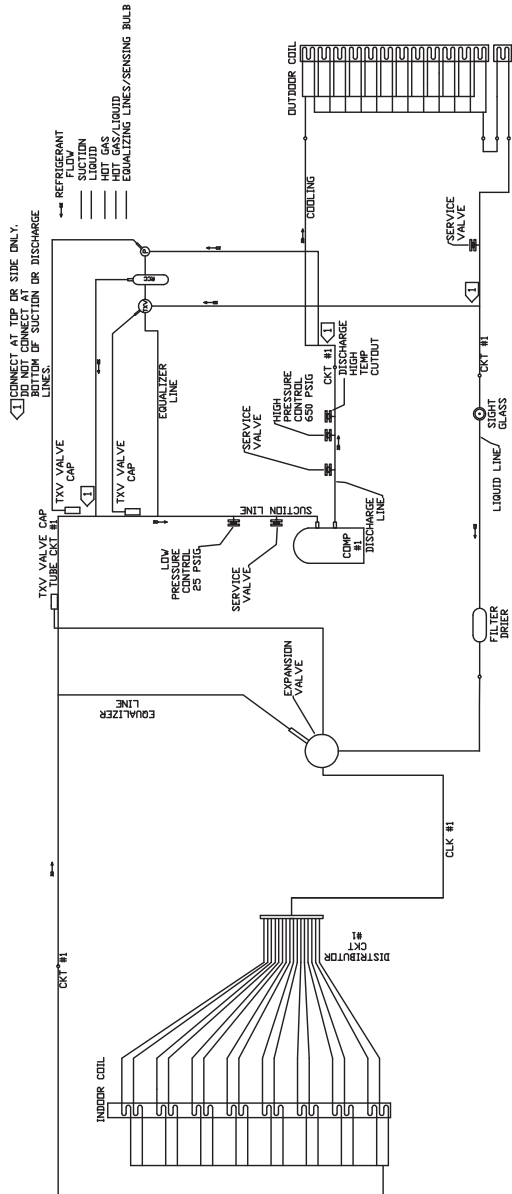

Figure 21. Refrigeration diagram: single compressor with reheat

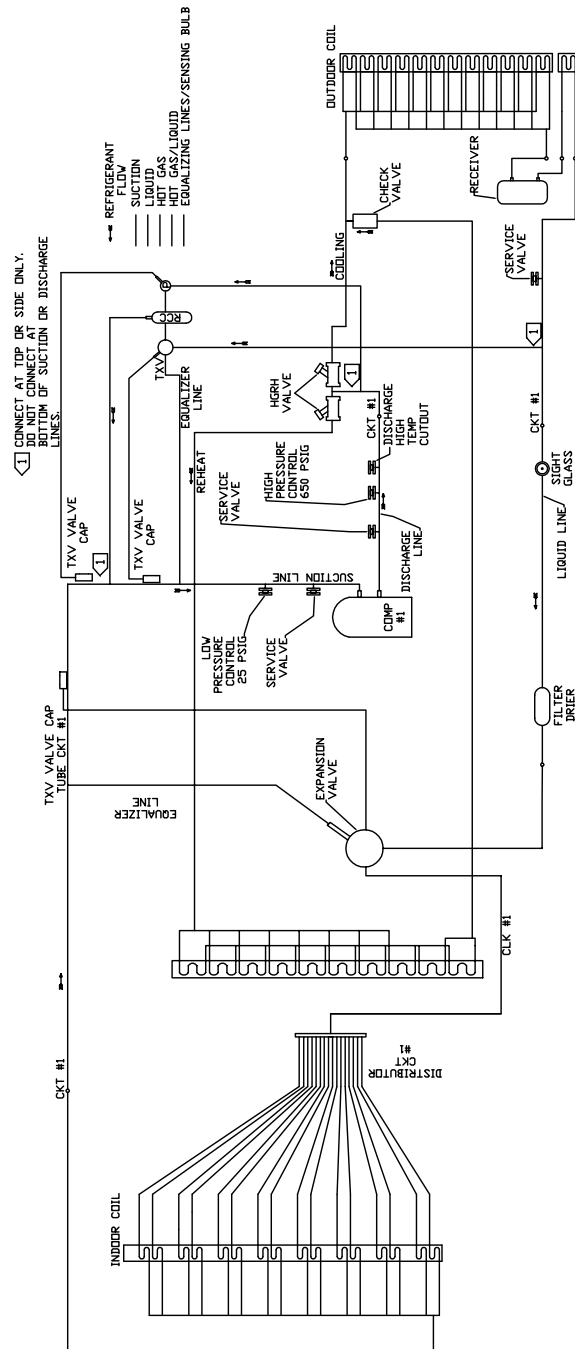

Figure 22. Refrigeration diagram: dual compressor without reheat

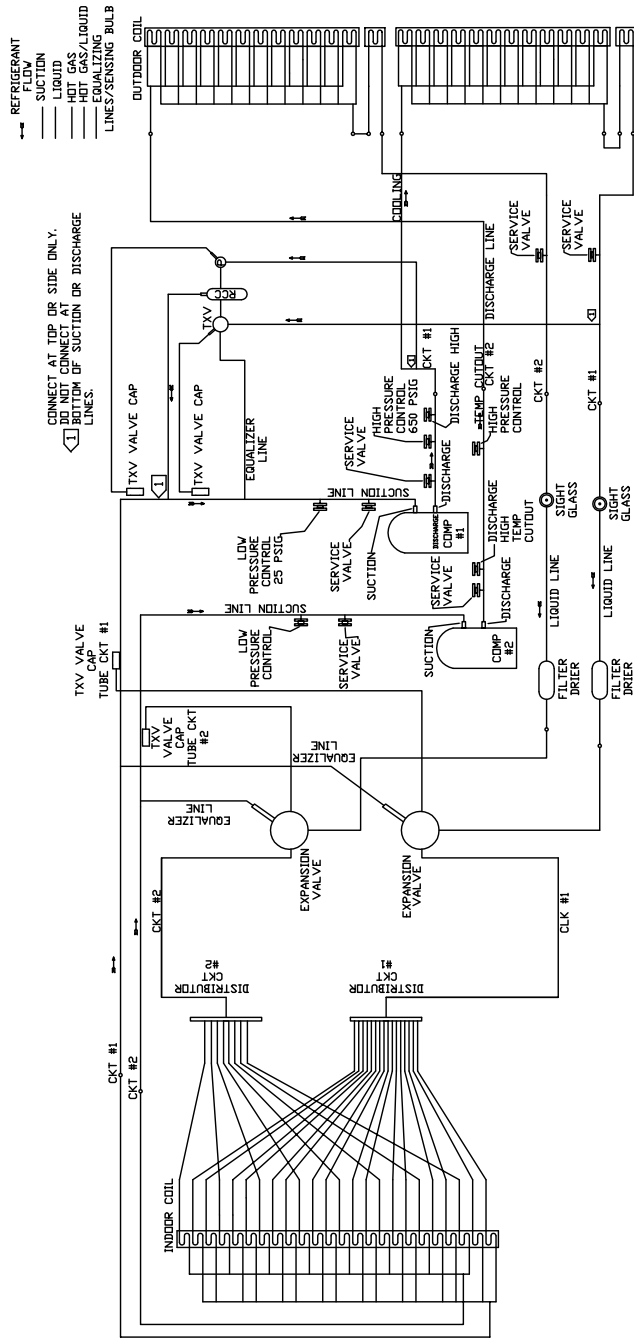
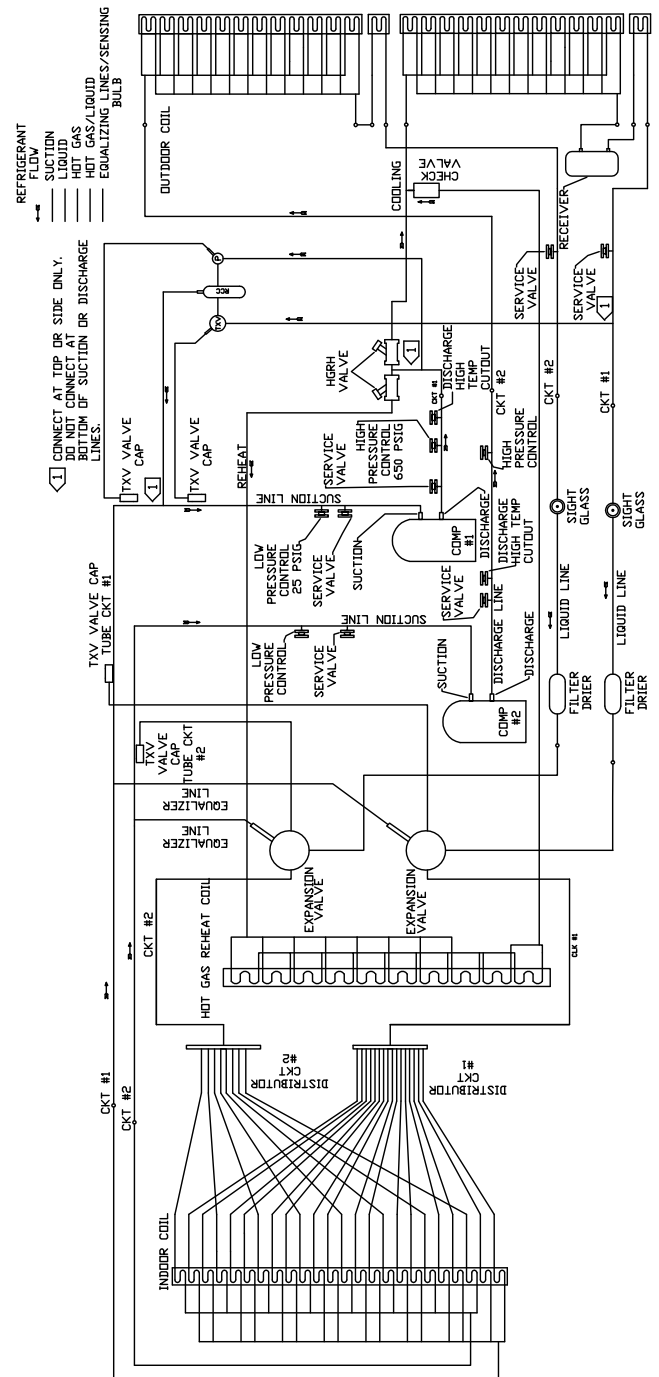

Figure 23. Refrigeration diagram: dual compressor with reheat





# Alarms and Troubleshooting

## Microprocessor Control

The Main Unit Display and RTRM have the ability to provide the service personnel with some unit diagnostics and system status information.

### ⚠ WARNING

#### Hazardous Service Procedures!

Failure to follow all precautions in this manual and on the tags, stickers, and labels could result in death or serious injury.

Technicians, in order to protect themselves from potential electrical, mechanical, and chemical hazards, **MUST** follow precautions in this manual and on the tags, stickers, and labels, as well as the following instructions: Unless specified otherwise, disconnect all electrical power including remote disconnect and discharge all energy storing devices such as capacitors before servicing. Follow proper lockout/tagout procedures to ensure the power can not be inadvertently energized. When necessary to work with live electrical components, have a qualified licensed electrician or other individual who has been trained in handling live electrical components perform these tasks.

### ⚠ AVERTISSEMENT

#### Procédures d'entretien dangereuses!

Le non-respect de toutes les précautions contenues dans ce manuel ainsi que sur les étiquettes et les autocollants peut entraîner des blessures graves voire mortelles.

Les techniciens, afin d'être protégés des éventuels risques électriques, mécaniques et chimiques, **DOIVENT** suivre les précautions contenues dans ce manuel, sur les étiquettes et les autocollants, ainsi que les instructions suivantes : Sauf indication contraire, coupez toute l'alimentation électrique y compris les disjoncteurs à distance et déchargez tous les dispositifs de stockage d'énergie comme les condensateurs avant l'entretien. Respectez les procédures de verrouillage et d'étiquetage appropriées pour éviter tout risque de remise sous tension accidentelle. S'il est nécessaire de travailler avec des composants électriques sous tension, demandez à un électricien qualifié et agréé ou à une autre personne ayant la formation nécessaire pour manipuler des composants électriques sous tension d'exécuter ces tâches.

1. Verify that the Liteport LED on the RTRM is burning continuously. If the LED is lit, go to [Step 3](#).
2. If the LED is not lit, verify that 24 Vac is presence between J1-1 and J1-2. If 24 Vac is present, proceed to [Step 3](#). If 24 Vac is not present, check the unit main power supply, check transformer (TNS1). Proceed to [Step 3](#) if necessary.
3. Utilizing "Method 1" in the RTRM "System Status Checkout Procedure", check the following:
  - System status
  - Cooling statusIf a System failure is indicated, proceed to [Step 4](#). If no failures are indicated, proceed to [Step 5](#).
4. If a System failure is indicated, recheck [Step 1](#) and [Step 2](#). If the LED is not lit in [Step 1](#), and 24 Vac is present in [Step 2](#), the RTRM has failed. Replace the RTRM.
5. If no failures are indicated, use one of the override options to start the unit. Following the Override procedure will allow you to check all of the operating modes, and all of the external controls (relays, contactors, etc.) for each respective mode.
6. Refer to the sequence of operations for each mode, to assist in verifying proper operation. Make the necessary repairs and proceed to [Step 7](#).
7. If no abnormal operating conditions appear in the Override mode, release the override and turn the power "Off" at the main power disconnect switch.

## System Alarms

The Main Unit Display has built in alarms to help the operator troubleshoot system failures. This section will describe these alarms and provide a guide to troubleshooting the all unit operating modes.

Comprehensive system alarms and diagnostics are accessed through the Alarms icon at the unit display discussed later in the section, or through Tracer TU programming on connected computer. Sensor failures may be viewed through the Alarms icon.

If an alarm is present, the main indicator light on the UC600 will blink red. If the optional unit display is installed, the Alarm icon on the display will register ALARM, illuminate red and flash.

**Important:** *The space temperature sensor (SPTC) and space relative humidity sensor (SPHC) will read failed if they are not connected; they will Alarm as "In Fault."*

## Sensor Failure Alarm Display

Press the Alarm button on the Home display of the Unit Display to display system sensor status as described in [Table 16](#), p. 62.



## Alarms and Troubleshooting

**Table 16. Diagnostic values**

	Name	Manual or Auto Reset	Possible Causes:
BV-01	Diagnostic: Supply Fan Failure	Manual Reset. Occurs when the supply fan is commanded on but the proving switch does not close after two minutes.	<ul style="list-style-type: none"> <li>VFD not operating OA and/or RA dampers not operating properly</li> <li>Indoor Fan Motor Failure</li> <li>Indoor Fan Failure Switch IFFS (pressure) failure</li> <li>IFFS tubing damaged or not properly connected</li> </ul>
BV-02	Diagnostic: Discharge Air Humidity Source Failure	Auto Reset. Occurs when the discharge air humidity sensor falls outside of range.	<ul style="list-style-type: none"> <li>BAS communication down</li> <li>Failed sensor or improper sensor installation</li> <li>Humidity Wiring Polarity sensitive</li> </ul>
BV-03	Diagnostic: Outdoor Air Damper End Switch	Auto Reset. Occurs when there is a call for the two-position outdoor air damper but the end switch has no made for 180 seconds.	<ul style="list-style-type: none"> <li>No voltage on actuator</li> <li>Failed OAD power transformer</li> <li>No continuity thru end switch ( check at UC)</li> </ul>
BV-06	Diagnostic: Discharge Air Temperature Source Failure	Auto Reset. Occurs when the discharge air temperature sensor falls outside of range.	<ul style="list-style-type: none"> <li>BAS Communication Down</li> <li>Failed sensor or improper sensor installation</li> </ul>
BV-08	Diagnostic: Fire Shutdown	Auto Reset. Diagnostic from BAS communication. Unit resets once this returns to normal.	<ul style="list-style-type: none"> <li>BAS only</li> </ul>
BV-10	Diagnostic: Low Discharge Air Temp Lockout	Manual Reset. Occurs when the discharge air temperature is below 35°F for five minutes, or ten minutes during heat pump defrost mode.	<ul style="list-style-type: none"> <li>Heat Overridden OFF</li> <li>Compressor(s) Overridden ON</li> <li>Setpoint Failures Incorrect</li> <li>DAT sensor malfunction</li> </ul>
BV-11	Diagnostic: Space Temperature Source Failure	Auto Reset. Occurs when the space temperature active falls outside of range.	<ul style="list-style-type: none"> <li>BAS communication down</li> <li>Failed sensor or improper sensor installation</li> </ul>
BV-13	Diagnostic: Outdoor Air Temperature Source Failure	Auto Reset. Occurs when the outdoor air humidity active falls outside of range.	<ul style="list-style-type: none"> <li>BAS Communication Down</li> <li>Failed sensor or improper sensor installation</li> </ul>
BV-14	Diagnostic: Outdoor Air Humidity Source Failure	Auto Reset. Occurs when the outdoor air temperature active falls outside of range.	<ul style="list-style-type: none"> <li>BAS communication down</li> <li>Failed sensor or improper sensor installation</li> <li>Humidity Wiring Polarity sensitive</li> </ul>
BV-15	Diagnostic: High Discharge Air Temp Lockout	Manual Reset. Occurs when the discharge air temperature is above 130°F for five minutes.	<ul style="list-style-type: none"> <li>Heat Overridden ON</li> <li>Low discharge air volume</li> <li>Dirty Air filters</li> <li>High gas heater manifold pressure</li> <li>OA/RA damper position incorrect</li> <li>High temp limit not properly installed or wired</li> <li>DAT sensor malfunction</li> </ul>

**Table 16. Diagnostic values (continued)**

	Name	Manual or Auto Reset	Possible Causes:
BV-19	Diagnostic: Space Humidity Source Failure	Auto Reset. Occurs when the space humidity active falls outside of range.	<ul style="list-style-type: none"> <li>• BAS communication down</li> <li>• Failed sensor or improper sensor installation</li> <li>• Humidity Wiring Polarity sensitive</li> </ul>
BV-22	Diagnostic: Compressor Fail Unit Lockout	Manual Reset.	Occurs when there is a compressor run failure and the discharge air temperature is 5°F from setpoint, or the dehumidification temperature is 5°F during dehumidification.
BV-24	Diagnostic: Exhaust Fan Failure	Auto Reset.	Occurs when there is a call for exhaust fan but there is no status for three minutes
BV-28	Diagnostic: Condensate Overflow Unit Lockout	Auto Reset.	<ul style="list-style-type: none"> <li>• Occurs when the condensate switch is open and the discharge air temperature is 5°F from setpoint, or the dehumidification temperature is 5°F during dehumidification.</li> <li>• Shuts down entire unit until 5 minutes after the condensate switch closes.</li> </ul>
BV-29	Diagnostic: Low Refrigerant Pressure Circuit 2	Auto Reset.	Occurs when circuit 2 is running and the suction pressure transducer reads below 90PSI (cooling) or 55PSI (heat pump) for two minutes.
BV-30	Diagnostic: Duct Static Pressure Setpoint Range	Auto Reset.	Occurs when the duct static setpoint is above 85% of the maximum limit for the hardwired input, below 5% of the full scale input, or less than the minimum.
BV-31	Diagnostic: Liquid Line Refrigerant Pressure Circuit 1 Source Failure	Auto Reset.	Occurs when circuit 1 is running and the liquid line transducer is outside of the 150- 650PSI range for two minutes.
BV-32	Diagnostic: Liquid Line Refrigerant Pressure Circuit 2 Source Failure	Auto Reset.	Occurs when circuit 2 is running and the liquid line transducer is outside of the 150- 650PSI range for two minutes.
BV-33	Diagnostic: Low Outdoor Coil Water Flow	Auto Reset.	<ul style="list-style-type: none"> <li>• Occurs when the supply fan is</li> <li>• running and the outdoor coil water flow switch is open.</li> </ul>
BV-34	Diagnostic: Dehumidification Temperature Sensor Source Failure	Auto Reset.	<ul style="list-style-type: none"> <li>• Occurs when the indoor coil leaving or discharge air temperature/ humidity sensor</li> <li>• falls outside of range.</li> </ul>
BV-35	Diagnostic: Compressor 1 Run Failure	Manual or Auto Reset.	<ul style="list-style-type: none"> <li>• Occurs when there is a call for a compressor without a run status for five minutes. Auto</li> <li>• resets after three hours.</li> </ul>
BV-36	Diagnostic: Duct Static Pressure Source Failure	Auto Reset.	<ul style="list-style-type: none"> <li>• Occurs when the supply duct</li> <li>• static pressure transducer reading falls outside of range.</li> </ul>
BV-37	Diagnostic: Outdoor Coil Water Temperature Low	Auto Reset.	Occurs when the supply fan is running and the outdoor coil water low temperature switch is open.
BV-38	Diagnostic: Low Refrigerant Pressure Circuit 1	Auto Reset.	Occurs when circuit 1 is running and the suction pressure transducer reads below 90PSI (cooling) or 55PSI (heat pump) for two minutes.

## Alarms and Troubleshooting

**Table 16. Diagnostic values (continued)**

	<b>Name</b>	<b>Manual or Auto Reset</b>	<b>Possible Causes:</b>
BV-42	Diagnostic: Heat Failure	Auto Reset (4 hours). Occurs when there is a call for heat but the heat status relay is not energized. The heat is cycled three times and then locked out for four hours before retrying.	<ul style="list-style-type: none"> <li>• Trips after heat command ON and no GV status offer 1 minute</li> <li>• No gas, low gas pressure or high gas pressure to unit</li> <li>• Unit Manual shutoffs closed</li> <li>• Heater inducer failure</li> <li>• Heat relay failure</li> <li>• Loose or incorrect wiring</li> </ul>
BV-46	Diagnostic: Not Economizing When It Should Be Economizing	Auto Reset.	Occurs when the unit is in economizer mode and the outdoor air damper feedback status is greater than 20% lower than the output.
BV-47	Diagnostic: Return Duct/Space Pressure Setpoint Range	Auto Reset.	Occurs when the duct static setpoint is above 85% of the maximum limit for the hardwired input, below 5% of the full scale input, or less than the minimum.
BV-48	Diagnostic: Damper Not Modulating	Auto Reset.	Occurs when the outdoor air damper position feedback is more than 20% off than the output.
BV-50	Diagnostic: Space CO2 Source Failure	Auto Reset.	Occurs when the space CO2 reading falls outside of range.
BV-52	Diagnostic: Compressor 2 Run Failure	Manual or Auto Reset.	Occurs when there is a call for a compressor without a run status for five minutes. Auto resets after three hours.
BV-53	Diagnostic: Compressor 3 Run Failure	Manual or Auto Reset.	Occurs when there is a call for a compressor without a run status for five minutes. Auto resets after three hours.
BV-54	Diagnostic: Compressor 4 Run Failure	Manual or Auto Reset.	Occurs when there is a call for a compressor without a run status for five minutes. Auto resets after three hours.
BV-55	Diagnostic: Return Duct/Space Pressure Source Failure	Auto Reset.	Occurs when the return duct/space pressure transducers falls outside of range.
BV-56	Diagnostic: Outdoor Airflow Sensor Source Failure	Auto Reset.	Occurs when the outdoor air damper is above 15% and the outdoor airflow measurement shows less than 50cfm.
BV-58	Diagnostic: Compressor 5 Run Failure	Manual or Auto Reset.	Occurs when there is a call for a compressor without a run status for five minutes. Auto resets after three hours.
BV-59	Diagnostic: Compressor 6 Run Failure	Manual or Auto Reset.	Occurs when there is a call for a compressor without a run status for five minutes. Auto resets after three hours.
BV-60	Diagnostic: Energy Recovery Wheel Rotation Failure	Auto Reset.	Occurs when there is a call for the ERV but rotation was not detected for five minutes.



## RTRM Failure Modes

### ⚠ WARNING

#### Live Electrical Components!

Failure to follow all electrical safety precautions when exposed to live electrical components could result in death or serious injury. When necessary to work with live electrical components, have a qualified licensed electrician or other individual who has been properly trained in handling live electrical components perform these tasks.

### ⚠ AVERTISSEMENT

#### Composants électriques sous tension!

Le non-respect de toutes les consignes de sécurité lors de la manipulation de composants électriques sous tension peut entraîner des blessures graves, voire mortelles. S'il est nécessaire de travailler avec des composants électriques sous tension, demandez à un électricien qualifié et agréé ou à une autre personne ayant la formation nécessaire pour manipuler des composants électriques sous tension d'exécuter ces tâches.

Following is the listing of RTRM failure indication causes.

### System Failure

Check the voltage between RTRM terminals 6 and 9 on J6, it should read approximately 32 Vdc. If no voltage is present, a System failure has occurred. Refer to [Step 4](#) in "Microprocessor Control," p. 61 for the recommended troubleshooting procedure.

### Cooling Failure

- CLP1 has opened during the 3 minute minimum "on time" during four consecutive compressor starts, check CLP1 by testing voltage between the J1-8 and J3-2 terminals on the RTRM and ground. If 24 Vac is present, the CLP has not tripped. If no voltage is present, CLP has tripped.

### System Failure

Measure the voltage between terminals J6-9 and J6-6.

Normal Operation = approximately 32 Vdc

System Failure = less than 1 Vdc, approximately 0.75 Vdc

### Cool Failure

Measure the voltage between terminals J6-8 and J6-6.

Cool Operating = approximately 32 Vdc

Cool Off = less than 1 Vdc, approximately 0.75 Vdc

Cooling Failure = voltage alternates between 32 Vdc and 0.75 Vdc

## Airflow Troubleshooting

Table 17. Airflow troubleshooting

Airflow	Profile Opening Width (in.)		
	6-in. Burner	12-in. Burner	18-in. Burner
500	6.5		
750	7.5		
1000	9		
1250	10		
1500	11-1/4		
1750	12-1/2		
2000	13-3/4		
2250	14-3/4		
2500	16	14	
2750	17-1/4	15	
3000	18-1/2	15-3/4	14-1/4
3250	19-3/4	16-3/4	15
3500	21	17-1/2	15-1/2
3750	22	18-1/4	16-1/4
4000	23-1/4	19-1/4	17
4250	24-1/2	20	17-1/2
4500	25-3/4	21	18-1/4
4750	27	21-3/4	18-3/4
5000		22-1/2	19-1/2
5250		23-1/2	20-1/4
5500		24-1/4	20-3/4
5750		25	21-1/2
6000		26	22
6250		26-3/4	22-3/4
6500		27-3/4	23-1/2
6750		28-1/2	24
7000		29-1/4	24-3/4
7250		30-1/4	25-1/4
7500		31	26

**Direct-Fired OAB and OAG Unit Flame Relays ≤ 400 MBh**
**⚠ WARNING**
**Hazardous Service Procedures!**

Failure to follow all precautions in this manual and on the tags, stickers, and labels could result in death or serious injury.

Technicians, in order to protect themselves from potential electrical, mechanical, and chemical hazards, **MUST** follow precautions in this manual and on the tags, stickers, and labels, as well as the following instructions: Unless specified otherwise, disconnect all electrical power including remote disconnect and discharge all energy storing devices such as capacitors before servicing. Follow proper lockout/tagout procedures to ensure the power can not be inadvertently energized. When necessary to work with live electrical components, have a qualified licensed electrician or other individual who has been trained in handling live electrical components perform these tasks.

**⚠ AVERTISSEMENT**
**Procédures d'entretien dangereuses!**

Le non-respect de toutes les précautions contenues dans ce manuel ainsi que sur les étiquettes et les autocollants peut entraîner des blessures graves voire mortelles.

Les techniciens, afin d'être protégés des éventuels risques électriques, mécaniques et chimiques, **DOIVENT** suivre les précautions contenues dans ce manuel, sur les étiquettes et les autocollants, ainsi que les instructions suivantes : Sauf indication contraire, coupez toute l'alimentation électrique y compris les disjoncteurs à distance et déchargez tous les dispositifs de stockage d'énergie comme les condensateurs avant l'entretien. Respectez les procédures de verrouillage et d'étiquetage appropriées pour éviter tout risque de remise sous tension accidentelle. S'il est nécessaire de travailler avec des composants électriques sous tension, demandez à un électricien qualifié et agréé ou à une autre personne ayant la formation nécessaire pour manipuler des composants électriques sous tension d'exécuter ces tâches.

**Table 18. Lockout models B, H D, and J only—Green LED status codes**

Green LED Flash Code <sup>(a)</sup>	Indicates	Next System Action	Recommended Service Action
OFF	No "Call for Heat"	Not applicable	None
Flash Fast	Power up - internal check	Not applicable	None
Heartbeat	Normal startup - ignition sequence started (including prepurge)	Not applicable	None
4 Seconds ON then "x" flashes	Device in run mode. "x" = flame current to the nearest $\mu$ A.	Not applicable	None
2	Lockout - Failed trial for ignition	Remain in lockout until "Call for Heat" is cycled.	Check gas supply, pilot burner, spark and flame sense wiring, flame rod contaminated or out of position, burner ground connection.
3	Recycle - Flame failed during run	Initiate new trial for ignition. Flash code will remain through the ignition trial until flame is proved.	If system fails to light on next trial for ignition, check gas supply, pilot burner, flame sense wiring, contamination of flame rod, burner ground connection.
4	Flame sensed out of sequence	If situation self corrects within 10 seconds, control returns to normal sequence. If flame out of sequence remains longer than 10 seconds, control will resume normal operation 1 hour after error is corrected.	Check for pilot flame. Replace gas valve if pilot flame present. If no pilot flame, cycle "Call for Heat." If error repeats, replace control.
6	Control Internal Error	Control remains in wait mode. When the fault corrects, control resumes normal operation.	Cycle "Call for Heat". If error repeats, replace control.
7	Flame rod shorted to ground	Control remains in wait mode. When the fault corrects, control resumes normal operation.	Check flame sense lead wire for damage or shorting. Check that flame rod is in proper position. Check flame rod ceramic for cracks, damage or tracking.
8	Low secondary voltage supply	Control remains in wait mode. When the fault corrects, control resumes normal operation.	Check transformer and AC line for proper input voltage to the control. Check with full system load on the transformer.

(a) Flash Code Descriptions:

- Flash Fast: Rapid blinking.
- Heartbeat: Constant 1/2 second bright, 1/2 second dim cycles.
- 4 second solid on pulse followed by "x" 1 second flashes indicates flame current to the nearest  $\mu$ A. This is only available in run mode.
- A single flash code number signifies that the LED flashes X times at 2 Hz, remains off for two seconds, and then repeats the sequence.

### Flame Current Measurement

Flame current of the device can be measured using a standard micro-ammeter by simply inserting the meter probes into the holes labeled FLAME CURRENT.

- Flame current must be measured with pilot valve lit but no main gas flowing.
- Disconnect MV leadwire from the control before measuring flame current.
- Set meter to DC  $\mu$ Amp scale.
- Ensure meter leads are positioned correctly [+/-].

**Note:** *Trying to measure the pilot flame current in series with the wiring will not be accurate.*

Recommended Minimum Pilot Only Flame Current:

- Must read steady 1  $\mu$ Amp DC minimum.
- Flame current should be 2  $\mu$ Amp or greater for reliable appliance operation.

### Direct-Fired OAG Unit Flame Relays > 400 MBh

**⚠ AVERTISSEMENT**

**Procédures d'entretien dangereuses!**

Le non-respect de toutes les précautions contenues dans ce manuel ainsi que sur les étiquettes et les autocollants peut entraîner des blessures graves voire mortelles.

Les techniciens, afin d'être protégés des éventuels risques électriques, mécaniques et chimiques, **DOIVENT** suivre les précautions contenues dans ce manuel, sur les étiquettes et les autocollants, ainsi que les instructions suivantes : Sauf indication contraire, coupez toute l'alimentation électrique y compris les disjoncteurs à distance et déchargez tous les dispositifs de stockage d'énergie comme les condensateurs avant l'entretien. Respectez les procédures de verrouillage et d'étiquetage appropriées pour éviter tout risque de remise sous tension accidentelle. S'il est nécessaire de travailler avec des composants électriques sous tension, demandez à un électricien qualifié et agréé ou à une autre personne ayant la formation nécessaire pour manipuler des composants électriques sous tension d'exécuter ces tâches.

**⚠ WARNING**

**Hazardous Service Procedures!**

Failure to follow all precautions in this manual and on the tags, stickers, and labels could result in death or serious injury.

Technicians, in order to protect themselves from potential electrical, mechanical, and chemical hazards, **MUST** follow precautions in this manual and on the tags, stickers, and labels, as well as the following instructions: Unless specified otherwise, disconnect all electrical power including remote disconnect and discharge all energy storing devices such as capacitors before servicing. Follow proper lockout/tagout procedures to ensure the power can not be inadvertently energized. When necessary to work with live electrical components, have a qualified licensed electrician or other individual who has been trained in handling live electrical components perform these tasks.

**Table 19. Troubleshooting guide for flame relays during problem of safety shutdown (lockout)**

Occurs In	Occurs If
Initiate Period	<ul style="list-style-type: none"> <li>• Purge card is not installed or removed</li> <li>• Purge card is bad</li> <li>• Configuration jumpers have been changed (after 200 hours)</li> <li>• AC line power errors occurred</li> <li>• Four minute INITIATE period has been exceeded</li> </ul>
Standby Period	<ul style="list-style-type: none"> <li>• Airflow lockout feature is enabled and the airflow switch does not close after ten seconds or within the specified purge card timing</li> <li>• Flame signal is detected after 30 seconds</li> <li>• Ignition/pilot valve/intermittent pilot valve terminal is energized</li> <li>• Main valve terminal is energized</li> <li>• Delayed (2<sup>nd</sup> stage) main valve terminal is energized (RM7895C, D/EC7895C, RM7896C/D)</li> <li>• Internal system fault occurred</li> <li>• Purge card is removed</li> <li>• Purge card is bad</li> </ul>

## Alarms and Troubleshooting

**Table 19. Troubleshooting guide for flame relays during problem of safety shutdown (lockout) (continued)**

Occurs In	Occurs If
Prepurge Period	<ul style="list-style-type: none"> <li>Airflow lockout feature is enabled and the airflow switch opens</li> <li>Ignition/pilot valve terminal is not energized</li> <li>No flame present at end of PFEP</li> <li>Main valve terminal is energized</li> <li>Delayed main valve terminal is energized (RM7895C/D)</li> <li>Internal system fault occurred</li> <li>Purge card is removed</li> <li>Purge card is bad</li> </ul>
Pilot Flame Establishing Period (PFEP)	<ul style="list-style-type: none"> <li>Airflow lockout feature is enabled and the airflow switch does not close after 10 seconds or within the specified purge card timing</li> <li>Flame signal is detected after 30 seconds</li> <li>Ignition/pilot valve/intermittent pilot valve terminal is energized</li> <li>Main valve terminal is energized.</li> <li>Delayed (2<sup>nd</sup> stage) main valve terminal is energized (RM7895C/D, EC7895C, RM7896C/D)</li> <li>Internal system fault occurred</li> <li>Purge card is removed</li> <li>Purge card is bad</li> </ul>
Main Flame Establishing Period (MFEP) -RM7895C/D, EC7895C, RM7896C/D	<ul style="list-style-type: none"> <li>Airflow lockout feature is enabled and the airflow switch opens</li> <li>Ignition terminal is energized</li> <li>Ignition/pilot valve terminal is not energized</li> <li>Main valve terminal is not energized</li> <li>Delayed main valve terminal is energized</li> <li>No flame present at end of MFEP</li> <li>Internal system fault occurred</li> <li>Purge card is removed</li> <li>Purge card is bad</li> </ul>
Run Period	<ul style="list-style-type: none"> <li>No flame present</li> <li>Airflow lockout feature is enabled and the airflow switch opens</li> <li>Interrupted pilot valve terminal is energized (RM7895C/D, EC7895C, RM7896C/D)</li> <li>Main valve terminal is not energized</li> <li>Delayed (2<sup>nd</sup> stage) main valve terminal is not energized (RM7895C/D, EC7895C, RM7896C/D)</li> <li>Internal system fault occurred</li> <li>Purge card is removed</li> <li>Purge card is bad</li> </ul>

**Figure 24. Wiring subbase and sequence chart for RM7895A/B, EC7895A, RM7896A/B**

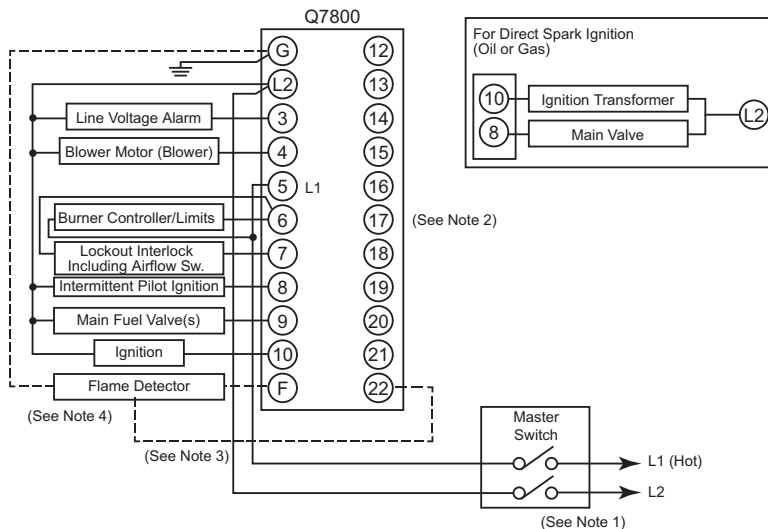

1. RM7895, RM7896; 120 Vac, 50/60 Hz; EC7895; 220–240 Vac, 50/60 Hz Power Supply. Provide disconnect means and overload protection as required.
2. Do not connect any wires to unused terminals.
3. For EC7895, A 220 to 240 Vac to 120 Vac, 10 VA minimum stepdown transformer (not provided) must be used to drive the shutter.
4. See flame detector specifications for correct wiring.
5. For RM7896A1048 (only), Ignition Terminal 1 is de-energized when flame is proven.
6. Airflow switch check feature is for the RM7895, RM7896B.
7. RM7896A,B (only).

	Initiate	Standby	Start	Time Purge	PFEP 4-10 Sec.	Run	Post Purge <sup>7</sup> 15 Sec.	Standby
LED Display	● Power ○ ○ ○	● Power ○ ○ ○	● Power ○ ○ ○	● Power ○ Pilot ○ Flame ○ Main ○ Alarm	● Power ○ Pilot ○ Flame ○ Main ○ Alarm	● Power ○ Pilot ○ Flame ○ Main ○ Alarm	● Power ○ Pilot ○ Flame ○ Main ○ Alarm	● Power ○ Pilot ○ Flame ○ Main ○ Alarm
Burner Start	Burner/Blower Motor (4)						Note 7	
	Ignition <sup>5</sup>							
	Ignition/Pilot (8)							
Operating Controls and Interlocks	Limits and Burner Controller Closed (L1) to (6)							
	Airflow Switch Check <sup>6</sup>		Lockout Interlock Closed (6) to (7)					AFSC
Flame Signal	Safe Start Check					Flame Proving		SSC

**Figure 25. Wiring subbase and sequence chart for RM7895C/D, EC7895C/D, RM7896C/D**

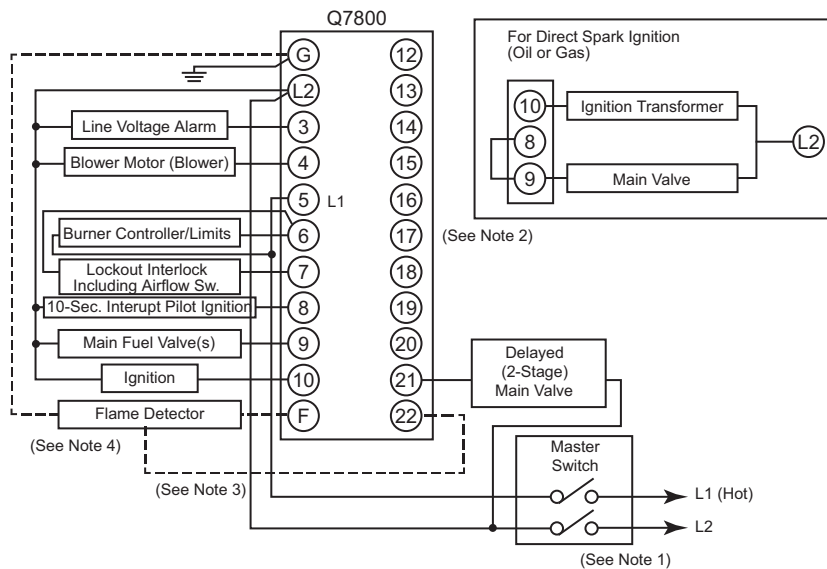

1. RM7895, RM7896; 120 Vac, 50/60 Hz; EC7895; 220–240 Vac, 50/60 Hz Power Supply. Provide disconnect means and overload protection as required.
2. Do not connect any wires to unused terminals.
3. For EC7895, A 220 to 240 Vac to 120 Vac, 10 VA minimum step down transformer (not provided) must be used to drive the shutter.
4. See flame detector specifications for correct wiring.
5. Airflow switch check feature is for the RM7895D, RM7896D.
6. RM7896C,D (only).
7. RM7895C1020, RM7896C1036 PFEP 10 seconds (only).
8. RM7895C1020, RM7896C1036; during first 8 seconds of PFEP. When a flame signal is detected, Terminal 10 is de-energized. If flame signal is lost, Terminal 10 will re-energize.



## Alarms and Troubleshooting

	Initiate	Standby	Start	Time Purge	PFEP <sup>7</sup> 4-10 Sec.	MFEP	Run	Post Purge <sup>6</sup> 15-Sec	Standby
LED Display	● Power ○ ○ ○ ○	● Power ○ ○ ○ ○	● Power ○ ○ ○ ○	● Power ○ Pilot ○ Flame ○ Main ○ Alarm	● Power ○ Pilot ○ Flame ○ Main ○ Alarm	● Power ○ Pilot ○ Flame ○ Main ○ Alarm	● Power ○ Pilot ○ Flame ○ Main ○ Alarm	● Power ○ Pilot ○ Flame ○ Main ○ Alarm	● Power ○ Pilot ○ Flame ○ Main ○ Alarm
Burner Start	Burner/Blower Motor						④		Note 6
	Ignition <sup>8</sup>					⑩			
	Ignition/Pilot						⑧		
	Main Valve						⑨		
Operating Controls and Interlocks	Limits and Burner Controller Closed						① to ⑥		
	Airflow Switch Check <sup>5</sup>		Lockout Interlock Closed				⑥ to ⑦		AFSC
Flame Signal	Safe Start Check			Flame Proving				SSC	



# Attention Startup or Service Technician

## Horizon UC600 v11.0 Released

The programming has gone through an overhaul. Take a moment to read through the Sequence of Operation included in this packet to familiarize yourself with the new operation.

**Note:** *Program v11.0 is not backwards compatible with previous Horizon units. The point configuration has changed, and suction pressure transducers are required for proper operation. In the future, a package will be made available that's backwards compatible with units manufactured after Jan 1st, 2019.*

## Documents Included in This Packet

1. Sequence of Operation – Full Horizon sequence, not unit-specific.
2. New Startup Form
3. Unit-Specific Points List – Points not relevant to the unit have been removed from this document.

## Unchanged from Previous Versions:

- All programming and points built in. UC600 determines sequence based on configurable points and what points are Out of Service (mostly Analog and Binary Inputs/Outputs).
- Verifying setpoints with the customer is recommended.

## Summary of Improvements

### Suction Pressure Monitoring

All units with compressors will come standard with a refrigeration suction pressure transducer on circuit one. Units with digital scroll on the second circuit will also have a transducer on the second circuit.

Suction pressure will be used during cooling and dehumidification to limit capacity to prevent frost on the evaporator. An informational diagnostic will be displayed if this occurs repeatedly.

### Compressor Run Status and Diagnostics

Each compressor will now have a run status by using the compressor auxiliary contactor. A diagnostic will be displayed if there is a call for a compressor with no status.

### Updated Point Names to Match Tracer SC

Where possible, all points will be updated so that they match with standard Tracer SC key names.

### Evaporator Leaving Temperature Setpoint Reset

Single Zone VAV and Space Control units: During dehumidification mode the unit will reset the evaporator setpoint by comparing the space conditions to the setpoints.

Previously a fixed setpoint for the evaporator temperature was used during dehumidification.

### Minimum Supply Airflow Setpoints

VAV units will now have separate minimum air flows during heating or cooling operation. Previously, the setting used was the highest value for all modes of operation. If these values are lower than a minimum outdoor airflow setpoint, then the outdoor air setpoint is used.

Single Zone VAV Mod. Airflow - Heating Mode Single Zone VAV will now modulate supply airflow to maintain space temperature. Previously it was constant volume during heating mode.

### Gas Heater Staging Off at Minimum Capacity

The first stage of gas heat will now stage off if the heat capacity is at minimum. Previously, the first stage of heat was locked on whenever the unit was in heating mode. 2- minute delays have been added to prevent short cycling.

### Reduced Hot Gas Reheat Purge Mode

Previously, if the hot gas reheat was above 0% for 30 minutes, it entered a 3-minute purge cycle at 100% signal. Now, if the hot gas reheat is between 10% and 50% for 30 minutes, it will enter a 2-minute purge cycle. First half is at 80% signal, second half is at 10% signal.

### Unit Shutdown Due to Condensate Overflow

If the condensate overflow switch signals an alarm, and the unit is far from meeting setpoint, the unit is shut down and a diagnostic is displayed. Condensate switch required.

### Liquid Line Pressure Setpoint Reset

For maximum efficiency, the liquid line pressure setpoint defaults to 325PSI during regular cooling mode. During dehumidification it resets to 450PSI for maximum reheat capacity in all conditions. Head Pressure Control is required.

### Modulating ERV Exhaust and Outdoor Air Bypass

All units with an Energy Recovery Wheel (ERV) will now have modulating bypass for both the outdoor (OA) and exhaust air (EA). Modulating OA bypass is used to prevent frosting of the ERV. Modulating EA bypass operates with the primary heater and is used to prevent overheating on mild days.

### Space Control or Single Zone VAV and OA Setpoints

Space Control or Single Zone VAV will no longer use the outdoor air setpoints if the unit has an ERV, or if the unit is not 100% outdoor air. Space conditions are used for determining all modes of operation.



## Attention Startup or Service Technician

---

### Discharge Air Temp. Reset for Single Zone VAV

Single Zone VAV controls cooling and heating to constant discharge air temperature, with the supply fan controlling to space conditions. To reduce energy usage during extremely low load days, the unit will reset the *Discharge Air Temperature Setpoint Active* whenever the supply airflow is within 10% of the minimum setpoint.

### Supply Fan Tracking for Exhaust Fan (Field Enabled)

VAV units can now have the exhaust fan track with the supply air as it changes speed. The exhaust fan speed will be 90% (adj.) of the supply fan speed.

### Hot Water Reheat

Units with hot water installed will default from the factory to use the hot water as reheat for chilled water, or supplement hot gas reheat when it's at 100% capacity.

### Expanded Fallback Control

Where possible, the unit will fall back to other methods of control when it detects a failed sensor. A diagnostic is displayed for the sensor when another sensor is being used.

- Evaporator temperature sensor fail -> use suction pressure.
- Supply duct static pressure sensor fail -> use constant volume at minimum airflow.
- Space temperature sensor fail -> use constant discharge air temperature.
- Space relative humidity sensor fail -> use constant evaporator leaving temperature.
- Expanded Diagnostics
- Refrigerant Pressure Diagnostics (Liquid or Suction) if they fall outside of acceptable ranges during operation.
- Water Flow or Temperature Diagnostics for the outdoor water coil if there is no flow or low temperature with a demand for heating or cooling (WSHP only).
- Compressor Run Fail Diagnostics if there is a command, but not a run status.
- Unit Shutdown Due to Compressor Diagnostics, Heat Fail, or Condensate Overflow will shut the unit down if cooling or heating is not working properly and the unit is supplying well outside of acceptable ranges.
- Return Duct/Space Pressure Source Fail when there is no input from the transducer.
- Duct Static Pressure Setpoint Range and Return Duct/Space Pressure Setpoint Range when the setpoints aren't within an acceptable range in comparison to the hardwired input. Alarm is shown when setpoint is:
  - Above 85% of max range,
  - Below min range,
  - Below 5% of the difference between the min and max.
- Outdoor Airflow Source Fail when the outdoor air damper is open, supply fan is on, but there's no airflow reading.





# Sequence of Operation

## General

Text shown in *italics* are point names in the programming.

Typically, points ending with "Local" are hardwired inputs, points ending with "Active" are determined by the program and can't be adjusted by the operator or BAS.

**Discharge Air Temperature Setpoint Maximum** is adjustable but cannot exceed 120°F for gas, heat pump, or hot water heating, and 90°F for electric heating.

**Program Control Type** can be determined using Multi-State Value 13.

**Note:** *There is a 3-minute delay during compressor or gas heater staging to allow the system to stabilize before adjusting the cooling or heating capacity.*

## Program-Controlled Setpoints

### Space Control and Single Zone VAV Control

*Discharge Air Temperature Setpoint Active* is reset by comparing the *Space Temperature Active* to *Occupied Cooling Setpoint* during cooling and *Occupied Heating Setpoint* during heating. If a single setpoint is preferred, use *Space Temperature Setpoint BAS* by putting it In Service using Tracer TU or BAS.

*Dehumidification Temperature Setpoint Active* is reset by comparing the *Space Dewpoint* to the *Space Dewpoint Calculated Enable Setpoint* minus 2°F.

If *Space Temperature Setpoint BAS* or *Space Temperature Setpoint Local* (Thumbwheel) is In Service, *Occupied Offset* is adjustable (2°F default). Otherwise, is determined using *Occupied Cooling Setpoint* and *Occupied Heating Setpoint*.

If *Occupied Cooling Setpoint* is below *Occupied Heating Setpoint*, *Occupied Offset* is 1°F. If *Occupied Cooling Setpoint* is above *Occupied Heating Setpoint*, *Occupied Offset* is the difference between the two setpoints.

*Space Dewpoint Calculated Enable Setpoint* is calculated using *Space Humidity Setpoint* and *Space Temperature Setpoint Active*.

### Discharge Air Control and Multi-Zone VAV Control

*Discharge Air Temperature Setpoint Active* is controlled by *Discharge Air Cooling Setpoint BAS* during cooling operation, and *Discharge Air Heating Setpoint BAS* during heating. If *Discharge Air Temperature Setpoint BAS* is In Service, the program will use this over the discharge cooling and heating setpoints.

*Dehumidification Temperature Setpoint Active* is controlled by *Dehumidification Temperature Setpoint*.

## Occupied Control

### Starting Sequence

Occupied operation begins when the unit is placed in Occupied via BAS or when OAUTS-7 & 8 is closed on the field wiring terminal strip. The unit must not be in *Emergency Stop* to begin starting sequence. OAUTS-9 & 10 on the field wiring terminal strip are used as an external *Emergency Stop* for the unit. Cycling power to unit to may not resolve alarm condition.

Refer to Multi-State Value *Occupancy Status* to determine the active status of the unit.

**Two-Position Outdoor Air Damper** will begin by energizing relay OADR, opening the outdoor air damper. The supply fan sequence begins once the end switch is closed.

**Two-Position Outdoor & Return Air Dampers** will begin by energizing relay OADR, opening the outdoor air damper and closing the return air damper. The supply fan sequence starts immediately after the unit becomes occupied.

**Modulating Outdoor & Return Air Dampers** will begin by adjusting the *Outdoor Air Damper Position Command* to meet the *Outdoor Air Damper Minimum Position Setpoint*. The supply fan sequence starts immediately after the unit becomes occupied.

### Supply Fan Sequence

**Supply Fan Starting Sequence** begins by energizing relay G and setting the *Supply Fan Speed Command* to 50%. The supply fan status switch (IFFS) closes, energizing relay IFFR. If after two minutes there is no proven signal, *Diagnostic: Supply Fan Failure* will be displayed, and the unit will shut down requiring a manual reset.

### Constant Volume with VFD

After completing the starting sequence, the supply fan will run to the *Supply Fan Speed Setpoint*, field adjustable from 50-100% (defaulted 100%).

### Constant Volume with ECM

After completing the starting sequence, the unit calculates the *Supply Fan Airflow Active* and adjusts *Supply Fan Speed Command* to maintain the *Supply Fan Airflow Setpoint* (adjustable, factory set according to submittal).

### Multi Zone VAV Control

After completing the starting sequence, the unit adjusts fan speed to maintain *Duct Static Pressure Active* to *Duct Static Pressure Setpoint BAS*. Supply fan speed is limited between *Supply Airflow Minimum Setpoint Active* and *Supply Airflow Maximum Setpoint* (both factory set).

### Single Zone VAV Control

After completing the starting sequence, the unit adjusts supply fan speed to maintain *Space Temperature Active* to *Space Temperature Setpoint Active*. When the unit is in



## Sequence of Operation

---

*Dehumidification Mode*, the unit adjusts the supply fan speed to maintain the *Space Dewpoint* to the *Space Dewpoint Calculated Enable Setpoint*.

Supply fan speed is limited between *Supply Airflow Minimum Setpoint Active* and *Supply Airflow Maximum Setpoint* (both factory set).

### Field Enabled Space Pressure Control

Units ordered as constant volume can be field enabled to control the supply fan speed to a pressure input. *Duct Static Pressure Local* must be put In Service, configured, and referenced to an open input using Tracer TU. The program will automatically adjust supply fan speed to maintain *Duct Static Pressure Setpoint BAS*.

## Economizer Mode

*Economizer Mode* is enabled when the *Outdoor Air Enthalpy* falls below Return Air Enthalpy and the *Outdoor Air Temperature Active* is below 80°F. *Economizer Mode* continues with a deadband of 3 BTU/lb, and 1°F for temperature. If the unit is not in *Free Cooling Mode* during *Economizer Mode*, the unit opens the outdoor air damper to the *Outdoor Air Damper Maximum Position Setpoint*. Mechanical cooling will not be locked out unless the unit is in *Free Cooling Mode*.

Refer to Multi-State Value *Economizer System Status* to determine the active status for the economizing.

**Free Cooling Mode** is enabled when the unit is in *Economizer Mode* and the *Outdoor Air Temperature Active* is cooler than five degrees below the *Discharge Air Temperature Setpoint Active*. During *Free Cooling Mode*, mechanical cooling is locked out and the unit adjusts the outdoor air damper position to maintain the *Discharge Air Temperature Setpoint Active*.

## Ventilation Mode

### Discharge Air Control

*Ventilation Mode* is enabled when the *Outdoor Air Temperature Active* is between the *Outdoor Air Cooling Enable Setpoint* and the *Outdoor Air Heating Enable Setpoint*. During *Ventilation Mode*, heating and cooling is locked out and the unit supplies un- conditioned air. *Ventilation Mode* is locked out whenever the unit is in *Dehumidification Mode*.

## Multi-Zone VAV Control

*Ventilation Mode* locked out.

### Space Control

*Ventilation Mode* is enabled when the *Outdoor Air Temperature Active* and the *Space Temperature Active* is within two degrees of the *Space Temperature Setpoint Active*. During *Ventilation Mode*, heating and cooling is locked out and the unit supplies un- conditioned air. *Ventilation Mode* is locked out whenever the unit is in *Dehumidification Mode*.

### Single Zone VAV Control

*Ventilation Mode* is enabled when the *Outdoor Air Temperature Active* and the *Space Temperature Active* is within two degrees of the *Space Temperature Setpoint Active*. During *Ventilation Mode*, heating and cooling is locked out, the supply fan goes to minimum airflow, and the unit supplies un- conditioned air. *Ventilation Mode* is locked out whenever the unit is in *Dehumidification Mode*.

## Primary Heating Mode

### Discharge Air Control

Heating Mode is enabled whenever the *Outdoor Air Temperature Active* is below the *Outdoor Air Heating Enable Setpoint*. During Heating Mode, *Heat Capacity* is adjusted to maintain the *Discharge Air Temperature Local* to *Discharge Air Temperature Setpoint Active*.

### Multi-Zone VAV Control

Heating Mode is enabled according to the graph shown in [Figure 26, p. 75](#). Using the graph, setpoint is *Discharge Air Temperature Setpoint Active*, offset is 2°F, and temperature is *Discharge Air Temperature Local*. *Dehumidification Mode* takes priority over Heating Mode. During Heating Mode, *Heat Capacity* is adjusted to maintain the *Discharge Air Temperature Local* to *Discharge Air Temperature Setpoint Active*.

### Space Control or Single Zone VAV Control, with Energy Recovery Wheel or has Mixed Air

Heating Mode is enabled according to the graph shown in [Figure 26, p. 75](#). Using the graph, setpoint is *Space Temperature Setpoint Active*, offset is *Occupied Offset*, and temperature is *Space Temperature Active*. *Dehumidification Mode* takes priority over Heating and Cooling Mode. During Heating Mode, *Heat Capacity* is adjusted to maintain the *Discharge Air Temperature Local* to *Discharge Air Temperature Setpoint Active*.

## Space Control or Single Zone VAV Control with No Energy Recovery Wheel and 100% Outdoor Air

Heating Mode is enabled whenever the *Outdoor Air Temperature Active* falls below the *Outdoor Air Heating Enable Setpoint*. When this occurs, cooling and dehumidification is not allowed, regardless of space conditions.

When the *Outdoor Air Temperature Active* is above the *Outdoor Air Heating Enable*, but below the *Outdoor Air Cooling Enable Setpoint*, Heating Mode is enabled according to the graph shown in [Figure 26, p. 75](#). Using the graph, setpoint is *Space Temperature Setpoint Active*, offset is *Occupied Offset*, and temperature is *Space Temperature Active*.

During Heating Mode, *Heat Capacity* is adjusted to maintain the *Discharge Air Temperature Local* to *Discharge Air Temperature Setpoint Active*.

**Figure 26. Heat cool mode arbitration graph.**

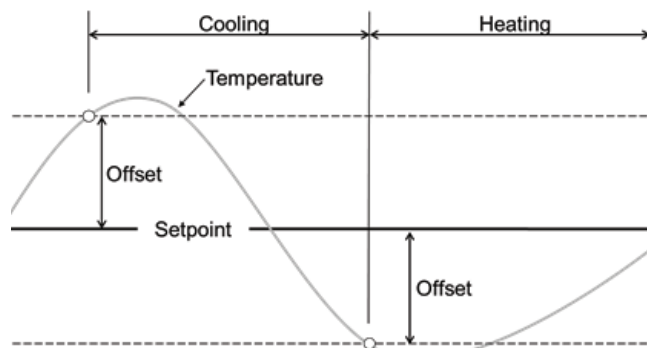

## Gas Heat Ignition Failure

The unit monitors the status of the heater using *Heat On Off Status Local*. In the event of ignition failure, the unit will make three ignition attempts before displaying *Diagnostic: Heat Failure*. The unit is shut down when a heat failure occurs and resets four hours later to re-attempt ignition.

## Heat Pump Heating Mode

Heat pump heating is enabled using the same criteria as Primary Heating Mode, except that heat pump is attempted first before using the primary heater. The same setpoints are used to adjust *Compressor Heating Capacity*. During heat pump operation the hot gas reheat is at 100%.

When the unit switches from heat pump to primary heating, *Auxiliary Heating Mode* changes to *Allowed*. *Auxiliary Heating Mode* is locked as *Allowed* for a minimum of fifteen minutes.

If the *Compressor Heating Capacity* is at 100%, and *Discharge Air Temperature Local* falls 3°F below the *Discharge Air Temperature Setpoint Active* for ten minutes, the unit toggles *Auxiliary Heating Mode* to *Allowed*, *Outdoor Air Temperature Active* is recorded as *Heat Pump Fail Switch Point*. Heat pump operation is re-attempted when the temperature rises by 5°F.

The unit switches *Auxiliary Heating Mode* to *Allowed* when the *Outdoor Air Temperature Active* falls below the *Heat Pump Disable Temperature Setpoint* (adj. 0-60°F, default 25°F).

## Water Source Heat Pump

*Outdoor Coil Water Flow Status* uses a differential pressure switch(es) across the supply and return to prove water flow. *Outdoor Coil Water Low Temperature Switch* uses temperature switch(es) on the return (35°F, water; 20°F, glycol). Heat pump operation is disabled if *Outdoor Coil Water Flow Status* goes Off for ten seconds, and immediately if the *Outdoor Coil Water Low Temperature Switch* is open.

## Air Source Heat Pump – Demand Defrost Control

Defrosting of the outdoor coil may occur when the *Outdoor Air Temperature Active* is below 52°F and the *Outdoor Coil Refrigerant Temperature Local* (Circuit 1 or 2) is below 35°F. The unit monitors the condenser conditions, and *Defrost Mode* is enabled once there is frost accumulation. During *Defrost Mode* the reversing valve(s) are switched into the cooling position and the condenser fans are shut off. The primary heat will be enabled on units with gas or hot water heat. Units with electric or no heat will close the outdoor damper (if installed).

## Cooling Mode

### Discharge Air Control

Cooling Mode is enabled whenever the *Outdoor Air Temperature Active* rises above the *Outdoor Air Cooling Enable Setpoint*. The *Outdoor Air Temperature Active* must be above the *Outdoor Air Heating Enable Setpoint*. During Cooling Mode, *Cooling Capacity* is adjusted to maintain *Discharge Air Temperature Setpoint Active*.

### Multi-Zone VAV Control

Cooling Mode is enabled according to the graph shown in [Figure 26, p. 75](#). Using the graph, setpoint is *Discharge Air Temperature Setpoint Active*, offset is 2°F, and temperature is *Discharge Air Temperature Local*. *Dehumidification Mode* takes priority over Cooling Mode. During Cooling Mode, *Cooling Capacity* is adjusted to maintain *Discharge Air Temperature Setpoint Active*.



## Sequence of Operation

---

### Space Control or Single Zone VAV Control, with Energy Recovery Wheel or has Mixed Air

Cooling Mode is enabled according to the graph shown in [Figure 26, p. 75](#). Using the graph, setpoint is Space Temperature Setpoint Active, offset is Occupied Offset, and temperature is Space Temperature Active. Dehumidification Mode takes priority over Cooling Mode.

### Space Control or Single Zone VAV Control with No Energy Recovery Wheel and 100% Outdoor Air

Cooling Mode is enabled whenever the Outdoor Air Temperature Active rises above the Outdoor Air Cooling Enable Setpoint. When this occurs, heating is not allowed, regardless of space conditions.

When the Outdoor Air Temperature Active is above the Outdoor Air Heating Enable, but below the Outdoor Air Cooling Enable Setpoint, Cooling Mode is enabled according to the graph shown in [Figure 26, p. 75](#). Using the graph, setpoint is Space Temperature Setpoint Active, offset is Occupied Offset, and temperature is Space Temperature Active.

### Compressor Low Ambient Lockout

On units without head pressure control, the compressors will be locked out if the Outdoor Air Temperature Active falls below the Compressor Low Ambient Lockout Setpoint and there is a demand for cooling. When this occurs, the unit will display Compressor Low Ambient Lockout Active as an informational diagnostic.

### Evaporator Frost Protection

Circuit 1 refrigeration pressure is monitored, and Cooling Capacity will be limited to prevent the indoor coil from freezing. If the unit has digital scroll on the second circuit, then both circuits will be monitored.

### Dehumidification Mode

Outdoor Air Dewpoint is calculated using Outdoor Air Temperature Active and Outdoor Air Humidity Active.

For Dehumidification Temperature Active, OAN Rev. 6 (OANG) cabinet uses Discharge Air Dewpoint (calculated using Discharge Air Temperature Local and Discharge Air Humidity Local), all other cabinets use Indoor Coil Leaving Air Temperature Local.

### Discharge Air Control

Dehumidification Mode is enabled whenever the Outdoor Air Dewpoint rises above the Outdoor Air Dewpoint Enable Setpoint. The Outdoor Air Temperature Active must be above Outdoor Air Heating Enable Setpoint.

During Dehumidification Mode, Cooling Capacity is adjusted to maintain the Dehumidification Temperature Setpoint Active, which is written to by Dehumidification Temperature Setpoint

(adjustable). Hot Gas Reheat Valve Command (if installed) is adjusted to maintain Discharge Air Temperature Setpoint Active.

### Multi-Zone VAV Control

Dehumidification Mode is enabled whenever the Outdoor Air Dewpoint rises above the Outdoor Air Dewpoint Enable Setpoint.

During Dehumidification Mode, Cooling Capacity is adjusted to maintain the Dehumidification Temperature Setpoint Active, which is written to by Dehumidification Temperature Setpoint (adjustable). Hot Gas Reheat Valve Command (if installed) is adjusted to maintain Discharge Air Temperature Setpoint Active.

### Space Control with Energy Recovery Wheel or has Mixed Air

Dehumidification Mode is enabled whenever the Space Dewpoint rises above the Space Dewpoint Calculated Enable Setpoint.

During Dehumidification Mode, the Dehumidification Temperature Setpoint Active is reset by comparing Space Dewpoint to Space Dewpoint Calculated Enable Setpoint minus 2°F. Hot Gas Reheat Valve Command (if installed) is adjusted to maintain Discharge Air Temperature Setpoint Active.

### Space Control with No Energy Recovery Wheel and 100% Outdoor Air

Dehumidification Mode is enabled whenever the Space Dewpoint rises above the Space Dewpoint Calculated Enable Setpoint, or when the Outdoor Air Dewpoint rises above the Outdoor Air Dewpoint Enable Setpoint.

During Dehumidification Mode, the Dehumidification Temperature Setpoint Active is reset by comparing Space Dewpoint to Space Dewpoint Calculated Enable Setpoint minus 2°F. Hot Gas Reheat Valve Command (if installed) is adjusted to maintain Discharge Air Temperature Setpoint Active.

### Hot Gas Reheat Purge

Hot Gas Reheat Purge Mode is initiated if the Hot Gas Reheat Valve Command is between 10% and 50% for thirty continuous minutes. During Hot Gas Reheat Purge Mode the signal first goes to 80% for one minute, then to 10% for one minute. The Hot Gas Reheat Valve Command returns to its previous position and will begin to modulate after a 30-second delay.

### Supplemental Electric Reheat (Not Included in Standard Operation)

If the Hot Gas Reheat Valve Command is at 100%, the SCR electric heat is enabled Heat Capacity at 0%. If Heat Capacity rises above 0%, the Hot Gas Reheat Valve Command will be locked at 100% and the electric heat will be used to maintain the Discharge Air Temperature Setpoint Active.



## Supplemental Hot Water Reheat

If the *Hot Gas Reheat Valve Command* is at 100%, the hot water valve is energized with *Heating Capacity* at 0%. If *Heat Capacity* rises above 0%, the *Hot Gas Reheat Valve Command* will be locked at 100% and the hot water will be used to maintain the *Discharge Air Temperature Setpoint Active*.

## Hot Water Reheat (No Hot Gas Reheat Installed)

During *Dehumidification Mode*, the hot water valve is energized by enabling *Heat 1 Command*, *Heat Capacity* is adjusted to maintain *Discharge Air Temperature Setpoint Active*.

## Exhaust Fan Operation

### With Isolation Exhaust Fan Damper(s)

After completing the Supply Fan Starting Sequence, *Exhaust Damper Open Close Command* is enabled. Once the *Exhaust Damper End Switch* has proven, *Exhaust Fan Start Stop Command* is enabled.

### Without Isolation Exhaust Fan Dampers

After completing the Supply Fan Starting Sequence, *Exhaust Fan Start Stop Command* is enabled.

### With Modulating OA/RA Dampers

Exhaust fan speed is controlled to *Duct/Space Pressure Setpoint*.

### ECM Exhaust with 2-Position OA Damper

Using the Exhaust Airflow Active from the exhaust fan piezo reading, the unit controls exhaust fan speed to a constant volume of according to the *Exhaust Airflow Setpoint*.

### VFD Exhaust with 2-Position OA Damper

The exhaust fan controls to a constant speed using *PEVFD Setpoint*.

## Energy Recovery Wheel Operation (ERV)

The *Energy Recovery Wheel Start Stop Command* is enabled whenever there is a call for exhaust fan. During *Ventilation Mode* or *Economizer Mode* the ERV is disabled, except during the cleaning cycle, which occurs for two minutes every thirty minutes.

During cooling operation, the *Energy Recovery Exhaust Air Bypass Position Command* is locked at 0% (closed position) for full energy recovery. During heating operation, the position is modulated to maintain the *Discharge Air Temperature Setpoint Active* for variable effectiveness capacity control. Once the bypass damper becomes fully closed, the primary heater will be engaged.

## Energy Wheel Without VFD

The unit prevents frost accumulation on the ERV by measuring the *Exhaust Leaving Temperature Local*. The *Energy Recovery Outdoor Air Bypass Position Command* is modulated open to maintain 15°F for the exhaust temperature. Above this temperature, the bypass damper will remain at 0% signal (closed) when the ERV is in operation.

## Energy Wheel With VFD

The unit prevents frost accumulation on the ERV by measuring the *Exhaust Leaving Temperature Local*. Initially the ERV speed is reduced to maintain 15°F for the exhaust temperature. If the ERV speed is at minimum, but the exhaust temperature remains below 15°F, the unit will maintain the temperature by modulating the *Energy Recovery Outdoor Air Bypass Position Command* open. During normal operation, the VFD is at 100% (full speed) and the bypass damper is at 0% (closed).

## Additional Features

### Electric Pre-Heat

*Pre-Heat Enable* is engaged whenever the *Exhaust Leaving Temperature Local* falls below 20°F, with a deadband of 5°F. The pre-heater is shut off if the *Preheat Leaving Temperature Local* rises above 90°F.

### Space Thumbwheel Input

#### Space Control and Single Zone VAV

With a space thumbwheel installed, the *Occupied Heating Setpoint* and *Occupied Cooling Setpoint* is replaced with a single setpoint from the input *Space Temperature Setpoint Local*. The occupancy override button will override *Occupancy Request* to Occupied for two hours from the time it was pressed.

### Split Exhaust and Return Air Path

When a unit is equipped with separate paths for the return and exhaust air, there will be a damper separating the two, and the powered exhaust shall not run below the minimum required speed to ensure exhaust air does not contaminate the supply air. A differential pressure sensor is used across the damper to verify a negative pressure on the exhaust side. Exhaust fan will be enabled during unoccupied mode. During *Economizer Mode* the damper between the two air paths will open, the return damper will close complete, and the outdoor damper will open to 100%.

### Outdoor Airflow Monitoring

Units with *Outdoor Airflow Local In Service* and Modulating Dampers installed will modulate the *Outdoor Air Damper Position Command* the *Outdoor Air Minimum Flow Setpoint*. Damper position is restricted between the *Outdoor Air Damper Minimum Position Setpoint* and *Outdoor Air Damper Maximum Position Setpoint*.



### Optional Field Enabled Features

#### Demand Control CO2 Ventilation

Modulating dampers are required for CO2 control. The unit will modulate the *Outdoor Air Damper Position Command* to maintain *Space CO2 Concentration Local* to *Space Concentration Setpoint*. The CO2 concentration can also be communicated to *Space CO2 Concentration BAS*.

CO2 Concentration must be field provided and installed.

#### Exhaust Fan Tracking

To enable exhaust fan tracking to the supply fan speed, set *Exhaust Fan Tracking Offset Setpoint* to In Service and adjust to the desired value (%). Putting this point In Service will override all other default speed control for the exhaust fan.

#### Static Pressure Control for Exhaust Fan

To enable exhaust fan control for a static pressure setpoint, set *Return Duct/Space Pressure Local* to In Service. The default input for this reading is XM70.2.U112, but the point can be configured to any open input on the controller. The unit will modulate the *Exhaust Fan Speed Output Command* to the *Return Duct/Space Pressure Local*.

If a setpoint less than 0.25" WC is desired. It's recommended to use a transducer that has a range of -0.5" WC to 0.5" WC.

### Unoccupied Operation

To enable heating, cooling, and dehumidification during unoccupied operation, the *BV Allow Unoccupied Operation* must be set as Allowed. Space conditions must be communicated via BAS or a hardwire space/temperature humidity sensor.

#### Starting Sequence

Unoccupied starting sequence begins when the Unoccupied Heating, Cooling, or *Dehumidification Mode* is enabled. Otherwise, the unit shall remain dormant with the supply fan disabled. Supply Fan Startup sequence is identical to occupied operation.

#### With Return Air Damper Installed

The outdoor air damper will be commanded to close, and the return air damper will open. If the unit is under Economizer conditions as described under the occupied section the *Outdoor Air Damper Position Command* will open to the *Outdoor Air Damper Maximum Position Setpoint*.

#### No Return Air Damper Installed

Identical to occupied starting sequence.

#### Unoccupied Heating Mode

*Unoccupied Heating Mode* is enabled when the *Space Temperature Active* falls below the *Unoccupied Heating Enable Setpoint*. During *Unoccupied Heating Mode* the unit

will run the heat to maintain 90°F for the discharge air temperature. *Unoccupied Heating Mode* is disabled when the *Space Temperature Active* rises 2°F above the *Unoccupied Heating Setpoint*.

#### Unoccupied Dehumid Mode

When there is no call for *Unoccupied Heating Mode*, *Unoccupied Dehumid Mode* is enabled when the *Space Dewpoint* rises above the *Unoccupied Dewpoint Enable Setpoint*. During *Unoccupied Dehumid Mode* the unit will run the cooling to maintain 45°F for the evaporator leaving temperature and reheat to 50°F for the discharge air temperature. *Unoccupied Dehumid Mode* is disabled when the *Space Dewpoint* rises 2°F above the *Unoccupied Dewpoint Enable Setpoint*.

#### Unoccupied Cooling Mode

When there is no call for *Unoccupied Heating Mode* or *Unoccupied Dehumid Mode*, *Unoccupied Cooling Mode* is enabled when the *Space Temperature Active* rises above the *Unoccupied Cooling Enable Setpoint*. During *Unoccupied Cooling Mode* the unit will run the cooling to maintain 50°F for the discharge air temperature. *Unoccupied Cooling Mode* is disabled when the *Space Temperature Active* rises 2°F above the *Unoccupied Cooling Enable Setpoint*.

### Diagnostics

The following list contains the diagnostics indicated by Binary Values or Binary Inputs. These are typically determined in the background of the program, and the status is written to these points.

Analog Inputs, Analog Values, or other points may also show alarms, which typically indicates that they are outside of the normal range or that communication to the device has been lost.

#### Energy Wheel with Optional Rotation Sensor

Units equipped with an optional rotation sensor detects rotation status using a proximity sensor that detects movement of the "pie" sections. If *Energy Recovery Wheel Start Stop Command* is enabled, but the *Energy Recovery Wheel Rotation Status Local* remains Off for five minutes, *Diagnostic: Energy Recovery Wheel Rotation Failure* will be displayed. This diagnostic is auto reset when rotation status is detected.

**Condensate Detection** Input will display a fault when the switch located in the condensate pan for the indoor coil has tripped.

**Emergency Stop** will display a fault if the Emergency Stop circuit is opened. Line 76 on the wiring diagram shows the circuit to energize the Emergency Stop Relays.

The unit is shut down when this diagnostic occurs, including the supply fan.

**Compressor Low Ambient Lockout Active** will display a fault if there is a demand for cooling according to the setpoints, but the *Outdoor Air Temperature Active* is below the

*Compressor Low Ambient Lockout Setpoint* and the unit does not have active head pressure control.

These diagnostic locks out compressor operation.

**Diagnostic: Compressor [1, 2,...] Run Failure** is displayed when there is a command for a compressor but there is no active status for the compressor. Compressor status is indicated using the NC contact on the compressor auxiliary contactor.

Upon an initial call for a compressor, there is a five minute and thirty second delay of no run status before an alarm is indicated. If there is five minutes of continuous operation with the run status, there is a thirty second delay before the alarm is displayed.

The program will disable the output for that compressor if there is run status alarm indicated. The diagnostic is cleared when there is an alarm reset or the diagnostic has been active for 3 hours.

**Diagnostic: Compressor Fail Unit Lockout** is displayed when there is a run failure diagnostic for one of the compressors and the unit is supplying unsatisfactory conditions for ten minutes. Unsatisfactory conditions are identified by the *Discharge Air Temperature Local* is 2°F above or below the *Discharge Air Temperature Setpoint Active* during Heat Pump Heating or Cooling Mode, or when the *Dehumidification Temperature Active* is 2°F below the *Dehumidification Temperature Setpoint Active* during *Dehumidification Mode*.

The unit is shut down when this diagnostic occurs, including the supply fan. The diagnostic can be cleared with an alarm reset and will auto-reset once the compressor run failure diagnostic is cleared.

**Diagnostic: Condensate Overflow Unit Lockout** is displayed when the *Condensate Detection Input* has failed, and the unit is supplying unsatisfactory conditions for five minutes. The unsatisfactory conditions use the same criteria as the *Diagnostic: Compressor Fail Unit Lockout*.

The unit is shut down when this diagnostic occurs, including the supply fan. The diagnostic will auto-reset five minutes after the condensate diagnostic has cleared.

**Diagnostic: Heat Failure** is displayed after three failed attempts to ignite the primary indirect fired gas heater within a four-hour period. The unit is shut down when this diagnostic occurs, including the supply fan

**Diagnostic: [High, Low] Discharge Air Temp Lockout** is displayed when the *Discharge Air Temperature Local* is [above 128°F, below 35°F] for a duration of 10 minutes. The diagnostic is manual reset using *Alarm Reset*.

**Diagnostic: Liquid Line Refrigerant Pressure Circuit [1,2] Source Failure** is displayed when the respective circuit is on (indicated by the compressor run status) and the *Liquid Line Refrigerant Pressure Circuit [1,2]* falls outside of the range of 150-650 PSI for a duration of two minutes. When this occurs, the condenser fans will run at 100%

**Diagnostic: Low Outdoor Coil Water Flow** is displayed if the supply fan is running but the *Outdoor Coil Water Flow Status*

indicates that there is no flow for 20-seconds. The compressors will be prevented from operating when this diagnostic occurs and will auto-reset once the flow returns.

The *Outdoor Coil Water Flow Status* is indicated using a differential pressure switch across the inlet and outlet of the water coils.

**Diagnostic: Outdoor Coil Water Temperature Low** is displayed if the supply fan is running but the *Outdoor Coil Water Low Temperature Switch* indicates that the water temperature is too low. The compressors will be prevented from operating when this diagnostic occurs and will auto-reset once the temperature switch closes.

The temperature switch is located on the water return and the switch opens at 35°F for water, 20°F for glycol

**Diagnostic: Low Refrigerant Suction Pressure Circuit [1,2]** is displayed when the respective circuit is on (indicated by the compressor run status) and the *Suction Line Refrigerant Pressure Circuit [1,2]* Local falls below 85 PSI (55 PSI for heat pump heating) for two continuous minutes. The diagnostic auto clears when the pressure returns to normal.

**Diagnostic: Outdoor Air Damper End Switch** is displayed when *Outdoor Air Damper Open Close Command* is On, but the *Outdoor Air Damper End Switch* does not prove for 3-minutes. The diagnostic is reset using *Alarm Reset* or when the end switch is proven.

**Diagnostic: Return Duct/Space Pressure Setpoint Range** is displayed when the *Return Duct/Space Pressure Setpoint* is set within 20% of the maximum limit of the *Return Duct/Space Pressure Local*. If the setpoint is set too close to the maximum range of the sensor, it will not be able to recognize when it's outside of the operating range.

**Diagnostic: Duct Static Pressure Setpoint Range** is displayed when the *Duct Static Pressure Setpoint BAS* is set within 20% of the maximum limit of the *Duct Static Pressure Local*. If the setpoint is set too close to the maximum range of the sensor, it will not be able to recognize when it's outside of the operating range.

**Diagnostic: Supply Fan Failure** is displayed when the *Supply Fan Start Stop Command* is On, but the *Supply Fan Status* does not prove for two minutes. The diagnostic requires a manual reset using *Alarm Reset*.

## Sensor Source Failures

The following diagnostics are displayed when the respective sensor reading is outside of the expected range, indicating that the sensor may be faulty. Refer to the points list for expected ranges of each input.

In some cases, a BAS point is In Service, and will take priority over a hardwired input. If the point was inadvertently put In Service, and the BAS is either not writing a value or the value is outside of the expected range, then the program will first attempt to fall back to a hardwired input before displaying a source failure diagnostic.

- Diagnostic: Dehumidification Temperature Sensor Source Failure\*



## Sequence of Operation

---

- Diagnostic: Discharge Air Humidity Source Failure
- Diagnostic: Discharge Air Temperature Source Failure
- Diagnostic: Duct Static Pressure Source Failure
- Diagnostic: Outdoor Airflow Sensor Source Failure
- Diagnostic: Outdoor Air Humidity Source Failure
- Diagnostic: Outdoor Air Temperature Source Failure
- Diagnostic: Return Duct/Space Pressure Source Failure
- Diagnostic: Space CO<sub>2</sub> Source Failure
- Diagnostic: Space Humidity Source Failure
- Diagnostic: Space Temperature Source Failure

\*The Dehumidification Temperature Sensor is the *Indoor Coil Leaving Air Temperature Local* on all cabinets except for the OANG (OAN Rev. 6). For the OANG cabinet, the sensor is the *Discharge Air Humidity Local*.

## Economizer Fault Detection and Diagnostics

**Not Economizing When It Should be Economizing** is displayed when unit is in *Economizer Mode* and the *Outdoor Air Damper Position Status Local* is 20% below the *Outdoor Air Damper Position Command* for 20-minutes.

**Damper Not Modulating** is displayed if the *Outdoor Air Damper Position Status Local* is 20% below the *Outdoor Air Damper Position Command* for 20-minutes.

**Mixed Air Low Limit Active** is displayed when the unit is in *Economizer Mode* and the unit is limiting the *Outdoor Air Damper Position Command* to prevent the mixed air temperature from falling below 35°F. Units equipped with Class 1A dampers will use a sensor, *Mixed Air Temperature Local*. Otherwise, the unit will estimate the mixed air temperature using *Outdoor Air Temperature Active*, *Return Air Temperature Local*, and the *Outdoor Air Damper Position Command*.

**Important:**





# Start-Up Form

## Trane<sup>®</sup> Horizon<sup>™</sup> DOAS

Job Name			
Unit Serial Number			
Unit Tag			
Technician Name			
Horizon Tech Training Completed	<input type="checkbox"/> Yes	<input type="checkbox"/> No	Date Completed:
Startup Date			

To get a digital copy of this form, please email [horizonstartup@kccmfg.com](mailto:horizonstartup@kccmfg.com).

For further questions please contact the factory at 502-493-5757.

### Pre-Startup Checklist

- Checked for visible shipping damage.
- Unit is level.
- All fans spin freely.
- All electrical connections tight.
- Interior cabinet inspected for damage or loose components.
- All field installed devices are installed.
- Clearances meet minimum requirements in IOM.
- Condensate drains and P-Traps installed.
- All doors open freely.
- Wiring schematics installed on front door.



## Start-Up Form

---

- Verify Indoor Fan Failure Switch (OAB, or OAG cabinets with UC600 controls)
  1. Note the minimum of Analog Values labelled Supply Fan Airflow Minimum Setpoint – Cooling Mode (AV59) and Supply Fan Airflow Minimum Setpoint – Heating Mode (AV13).
  2. Override Analog Output labelled Supply Fan Speed Command (AO2) until the Supply Fan Airflow Active (AV41) matches the value from step 1.
  3. Locate the Indoor Fan Failure Switch (IFFS) in the control section.
    - a. Labelled IFFS or two red wires labelled IFFS/464A.
  4. Slowly rotate IFFS switch clockwise (lightly tapping the IFFS after each full turn) until IFFR relay is not lit.
  5. Rotate IFFS switch ½ turn counterclockwise. IFFR relay should then be lit.
  6. Release Supply Fan Speed Command

- Verify Indoor Fan Failure Switch (OAD, OAK or OAN cabinets with UC600 controls and all units without UC600)
  1. Set the unit at minimum airflow:
    - a. For OAD, OAK or OAN with UC600, override Supply Fan Speed Command to 0%.
    - b. For all Units without UC600, have the controls contractor set the supply fan speed so that the airflow is at minimum.
  2. Locate the Indoor Fan Failure Switch (IFFS) in the control section.
    - a. Labelled IFFS or two red wires labelled IFFS/464A.
  3. Slowly rotate IFFS switch clockwise (lightly tapping the IFFS after each full turn) until IFFR relay is not lit.
  4. Rotate IFFS switch ½ turn counterclockwise. IFFR relay should then be lit.
  5. Release Supply Fan Speed Command override.

## Voltages

Rated Voltage	Measured
Voltage L1-L2	
Voltage L1-L3	
Voltage L2-L3	
Voltage L1-G	
Voltage L2-G	
Voltage L3-G	
TNS2 Secondary Voltage	

### Motor Data

Motor	Model Number	Rated HP/kW	Rated FLA	Running FLA		
				L1	L2	L3
Supply Fan 1						
Supply Fan 2						
Exhaust Fan 1						
Exhaust Fan 2						
Condenser Fan 1						
Condenser Fan 2						
Condenser Fan 3						
Condenser Fan 4						
Condenser Fan 5						
Condenser Fan 6						
ERV						

### Compressor Data

	Model Number	Serial Number	Rated Amps	Running Amps		
1						
2						
3						
4						
5						
6						

### Actuators

Actuator Name	Control	Operation Verified
Outdoor Air Damper Actuator	2-Position or 2-10 VDC	<input type="checkbox"/>
Return Air Damper Actuator	2-Position or 2-10 VDC	<input type="checkbox"/>
Exhaust Damper Actuator(s)	2-Position	<input type="checkbox"/>
Split Exhaust/Return Damper Actuator	2-Position	<input type="checkbox"/>
Outdoor Air ERV Bypass Damper Actuator	2-10 VDC	<input type="checkbox"/>
Exhaust Air ERV Bypass Damper Actuator	2-10 VDC	<input type="checkbox"/>
WSHP Water Valve Actuator(s)	2-10 VDC	<input type="checkbox"/>
Chilled Water Valve Actuator (Field Supplied)	-	<input type="checkbox"/>
Hot Water Valve Actuator (Field Supplied)	-	<input type="checkbox"/>



## Start-Up Form

# Refrigeration Start-up

## Test Procedures

**Important:** Cooling startup can only be completed if the OA temp is >65°F or <105°F. Heating startup can only be completed if OA temp is <90°F

1. Test each circuit independently.
2. Tandem or trio circuits must have all compressors on.
3. Set Digital Scroll/Variable Speed command to 100%\*.
4. Outdoor Air Damper open, Return Air Damper closed.
5. Set hot gas reheat to 25%\* (if installed).
6. Set outdoor air coil conditions.
  - a. Air Source Heat Pump or Standard DX

- i. Reduce condenser fan airflow until liquid line pressure is 375-400PSI.
- b. Water Source Heat Pump
  - i. Verify proper water flow through water coil.
7. Adjust charge until subcooling is 10-15.
8. Record all readings.
9. Verify HGRH operational at 100%
10. Heat Pumps: Switch reversing valve to heating, repeat steps 1-8 for heating mode except with hot gas reheat at 100%.
11. Repeat for Circuit 2.

**Note:** If saturated suction >67°F, you can test both circuits at the same time.

\* Units with variable speed compressor (VFD on compressor 1) must also be tested at 0% signal and 100% hot gas reheat.

		Circuit 1		Circuit 2		VS Test 2
		Cooling	Heating	Cooling	Heating	
		Outdoor Temp (°F)				
		Outdoor RH (%)				
		Hot Gas Reheat Signal (%)				
Discharge Line	Pressure (PSI)					
	Sat. Temp (°F)					
	Temp (°F)					
Suction Line	Pressure (PSI)					
	Sat. Temp (°F)					
	Temp (°F)					
	Superheat (°F)					
Liquid Line	Pressure (PSI)					
	Sat. Temp (°F)					
	Temp (°F)					
	Subcooling (°F)					
		Evaporator Leaving Temp (°F)				
WSHP Only	Entering Water Temp (°F)					
	Leaving Water Temp (°F)					
	Water Coil Pressure Drop (PSI)					

## Indirect Fired Gas Heat Start-up

### Furnace Data

	Serial Number	Model Number
Furnace 1		
Furnace 2		
Furnace 3		

### Gas Pressure Settings

	Measured Pressure	Natural Gas Settings	Propane Settings	
Incoming to Unit		7 – 14	11 – 14	in.H2O
Between On/Off & Mod. Valve		5	10.5	in.H2O
Stage 1 Manifold (Low Fire)		0.4	1.2	in.H2O
Stage 1 Manifold (High Fire)		3.5	8	in.H2O
Stage 2 Manifold		3.5	8	in.H2O
Stage 3 Manifold		3.5	8	in.H2O

## Electric Heat Start-up

### Heater Data

		Primary Heater	Pre-Heater
Item Number			
Rated kW			
Rated Amps			
Running Amps	L1		
	L2		
	L3		



## Programming and Commissioning

### Program Control Type (MV-13)

Select the sequence of operation and whether the unit will operate with a Build Automation System (BAS) or as a standalone unit.

- Space Control
- Discharge Air Control
- Single Zone VAV
- Multi Zone VAV
- BAS Control
- Standalone Control

### Description

Setpoints are pre-set at the factory using submittal data. It's highly recommended to compare the factory values to the customer's expectations to make sure it meets their requirements.

Review the Typical Setpoints on the next page and reference the Sequence of Operation for more detail.

Some of the setpoints have either a local version or a BAS version. If there are both versions of the points, then the BAS point will always take priority when it is set to In Service. Typically, these points are set Out of Service from the factory.

If possible, generate a Point Summary Report using Tracer TU after startup and submit that along with this startup report. The report is generated by going to Reports at the top left, Point Summary Report, and then Generate Report on the popup window. None of the checkboxes need to be checked.

### Commissioning

Do not attempt to perform commissioning by putting points Out of Service and setting a value. The program looks for points that are In Service or Out of Service to change the operation.

Instead, override the analog and binary values to "trick" the unit into modes of operation. When commissioning is complete, release the override on these points to resume normal operation. It's recommended to use a timed override so that it will auto-release.

**Example:** The unit uses Discharge Air Control and the commissioning agent wants to see the unit enter Cooling Mode. You look through the setpoints and find that the Outdoor Air Cooling Enable Setpoint is 65°F.

To put the unit into Cooling Mode the Outdoor Air Temperature must be above this setpoint. You put the unit into Cooling Mode by overriding the Outdoor Air Temperature Active (AV76) at a priority of 8 (default for TD7) and set it above 65°F.

#	BACnet Point Name	Setting	Default	Range	Units	Description
<b>DISCHARGE AIR CONTROL</b>						
AV-29	Outdoor Air Cooling Enable Setpoint		-	45–100	°F	When the Outdoor Air Temperature is above this setpoint, the unit will be locked into Cooling Mode.
AV-33	Outdoor Air Heating Enable Setpoint		-	15–75	°F	When the Outdoor Air Temperature is below this setpoint, the unit will be locked into Heating Mode (takes priority over Dehumidification Mode).
AV-10	Outdoor Air Dewpoint Enable Setpoint		-	45–100	°F	When the Outdoor Air Dewpoint is above this setpoint, the unit will be locked into Dehumidification Mode (takes priority over Cooling Mode).
AV-30	Discharge Air Cooling Setpoint BAS		60	45–90	°F	Discharge air setpoint during Cooling and Dehumidification Mode.
AV-32	Discharge Air Heating Setpoint BAS		65	45–100	°F	Discharge air setpoint during Heating Mode.
AV-67	Discharge Air Temperature Setpoint BAS		55	40–125	°F	Discharge air setpoint used during Heating, Cooling, and Dehumidification Mode. Factory defaulted Out of Service, put In Service to use.
<b>SPACE CONTROL AND SINGLE ZONE VAV</b>						
AV-87	Space Humidity Setpoint		45	0–100	%	Temperature setpoint and this setpoint is used to calculate a Space Dewpoint Setpoint, which puts the unit into Dehumidification Mode.
AV-01	Occupied Cooling Setpoint		72	55–85	°F	Space cooling setpoint used in occupied mode.
AV-02	Occupied Heating Setpoint		70	55–85	°F	Space heating setpoint used in occupied mode.
AV-25	Space Temperature Setpoint BAS		72	62–80	°F	Communicated space temperature setpoint (overwrites Occupied Cooling and Heating Setpoints). Factory defaulted Out of Service, put In Service to use.
<b>MULTI ZONE VAV</b>						
AV-10	Outdoor Air Dewpoint Enable Setpoint		55	45–100	°F	When the Outdoor Air Dewpoint is above this setpoint, the unit will be locked into Dehumidification Mode (takes priority over Cooling Mode).
AV-30	Discharge Air Cooling Setpoint BAS		60	45–90	°F	Discharge air setpoint during Cooling and Dehumidification Mode.
AV-32	Discharge Air Heating Setpoint BAS		65	45–100	°F	Discharge air setpoint during Heating Mode.
AV-67	Discharge Air Temperature Setpoint BAS		55	40–125	°F	Discharge air setpoint used during Heating, Cooling, and Dehumidification Mode. Factory defaulted Out of Service, put In Service to use.
<b>AIR BALANCE</b>						
AV-39	Supply Fan Airflow Setpoint		Varies	0–25000	cfm	Setpoint used to control the supply fan for constant volume. Only used on OAB and OAG cabinets (not VAV).
AV-46	Duct Static Pressure Setpoint BAS		1.5	-1–6	in.H2O	Setpoint used to control supply fan to static pressure. Factory default range is 0-2"WC, but can be re-configured for 0-5"WC.
AV-40	Exhaust Fan Speed Setpoint BAS		80	0–100	%	Setpoint used for constant speed exhaust fan. Used on OAD, OAK, and OAN cabinets that have exhaust, but do not have modulating OA/RA dampers.
AV-57	Exhaust Fan Airflow Setpoint		Varies	0–25000	cfm	Setpoint used for constant volume exhaust fan control. Used on OAB and OAG cabinets that have exhaust, but do not have modulating OA/RA dampers.
AV-48	Outdoor Air Damper Minimum Position Setpoint		Varies	0–100	%	Setpoint used to limit the outdoor air damper position during all operation. Typically adjusted during air balance. Factory set at an estimate based on submittal data.



## Start-Up Form

---

### Final Notes

Is there something missing or do you have recommendations on improvements?

Note here if the outdoor air temperature is too low for cooling testing.

Submit completed form to [horizonstartup@kccmfg.com](mailto:horizonstartup@kccmfg.com)  
Include serial number and job name in subject of email.





Trane - by Trane Technologies (NYSE: TT), a global climate innovator - creates comfortable, energy efficient indoor environments for commercial and residential applications. For more information, please visit [trane.com](https://trane.com) or [tranetechnologies.com](https://tranetechnologies.com).

Trane has a policy of continuous product and product data improvement and reserves the right to change design and specifications without notice. We are committed to using environmentally conscious print practices.