



Installation, Operation, and Maintenance

Separated Combustion Indoor Gas Fired Make-Up Air Units

For Heating, Cooling and Ventilating Systems

Models:

GXAA GXCA
GXBA GXDA

▲ SAFETY WARNING

Only qualified personnel should install and service the equipment. The installation, starting up, and servicing of heating, ventilating, and air-conditioning equipment can be hazardous and requires specific knowledge and training. Improperly installed, adjusted or altered equipment by an unqualified person could result in death or serious injury. When working on the equipment, observe all precautions in the literature and on the tags, stickers, and labels that are attached to the equipment.



Introduction

Read this manual thoroughly before operating or servicing this unit.

Warnings, Cautions, and Notices

Safety advisories appear throughout this manual as required. Your personal safety and the proper operation of this machine depend upon the strict observance of these precautions.

The three types of advisories are defined as follows:



Indicates a potentially hazardous situation which, if not avoided, could result in death or serious injury.



Indicates a potentially hazardous situation which, if not avoided, could result in minor or moderate injury. It could also be used to alert against unsafe practices.



Indicates a situation that could result in equipment or property-damage only accidents.

Important Environmental Concerns

Scientific research has shown that certain man-made chemicals can affect the earth's naturally occurring stratospheric ozone layer when released to the atmosphere. In particular, several of the identified chemicals that may affect the ozone layer are refrigerants that contain Chlorine, Fluorine and Carbon (CFCs) and those containing Hydrogen, Chlorine, Fluorine and Carbon (HCFCs). Not all refrigerants containing these compounds have the same potential impact to the environment. Trane advocates the responsible handling of all refrigerants-including industry replacements for CFCs and HCFCs such as saturated or unsaturated HFCs and HCFCs.

Important Responsible Refrigerant Practices

Trane believes that responsible refrigerant practices are important to the environment, our customers, and the air conditioning industry. All technicians who handle refrigerants must be certified. The Federal Clean Air Act (Section 608) sets forth the requirements for handling, reclaiming, recovering and recycling of certain refrigerants and the equipment that is used in these service procedures. In addition, some states or municipalities may have additional requirements that must also be adhered to for responsible management of refrigerants. Know the applicable laws and follow them.

<p style="text-align: center;">⚠ WARNING</p> <p>Proper Field Wiring and Grounding Required! Failure to follow code could result in death or serious injury. All field wiring MUST be performed by qualified personnel. Improperly installed and grounded field wiring poses FIRE and ELECTROCUTION hazards. To avoid these hazards, you MUST follow requirements for field wiring installation and grounding as described in NEC and your local/state/national electrical codes.</p>
--

⚠ WARNING**Personal Protective Equipment (PPE) Required!**

Failure to wear proper PPE for the job being undertaken could result in death or serious injury.

Technicians, in order to protect themselves from potential electrical, mechanical, and chemical hazards, **MUST** follow precautions in this manual and on the tags, stickers, and labels, as well as the instructions below:

- Before installing/servicing this unit, technicians **MUST** put on all PPE required for the work being undertaken (Examples; cut resistant gloves/sleeves, butyl gloves, safety glasses, hard hat/bump cap, fall protection, electrical PPE and arc flash clothing). **ALWAYS** refer to appropriate Safety Data Sheets (SDS) and OSHA guidelines for proper PPE.
- When working with or around hazardous chemicals, **ALWAYS** refer to the appropriate SDS and OSHA/GHS (Global Harmonized System of Classification and Labelling of Chemicals) guidelines for information on allowable personal exposure levels, proper respiratory protection and handling instructions.
- If there is a risk of energized electrical contact, arc, or flash, technicians **MUST** put on all PPE in accordance with OSHA, NFPA 70E, or other country-specific requirements for arc flash protection, **PRIOR** to servicing the unit. **NEVER PERFORM ANY SWITCHING, DISCONNECTING, OR VOLTAGE TESTING WITHOUT PROPER ELECTRICAL PPE AND ARC FLASH CLOTHING. ENSURE ELECTRICAL METERS AND EQUIPMENT ARE PROPERLY RATED FOR INTENDED VOLTAGE.**

⚠ WARNING**Toxic Fumes and Fibers!**

Install, operate and maintain unit in accordance with manufacturer's instructions to avoid exposure to fuel substances or substances from incomplete combustion which could result in death or serious illness. The State of California has determined that these substances may cause cancer, birth defects, or other reproductive harm. Install and Service this product to avoid exposure to airborne particles of glasswool fibers and/or ceramic fibers known to the State of California to cause cancer through inhalation.

Copyright

This document and the information in it are the property of Trane, and may not be used or reproduced in whole or in part without written permission. Trane reserves the right to revise this publication at any time, and to make changes to its content without obligation to notify any person of such revision or change.

Trademarks

All trademarks referenced in this document are the trademarks of their respective owners.



Table of Contents

Receiving Instructions	6
Pre-Installation Instructions.....	6
General Safety Requirements.....	7
Location	9
Combustion Air Considerations	9
Locations to Avoid	9
Mounting Height.....	9
Suspension and Rigging.....	10
Installation.....	14
Single Furnace Units	14
Multiple Furnace Units	14
Installing Flexible Connector.....	14
Installation Clearances	20
Venting†	22
Duct Connections	23
Gas Piping††	23
Modulating Gas Control (Optional)*	25
Electrical Connections.....	25
DX Coil Equipped Units (Optional).....	27
Chilled Water Coil Equipped Units (Optional).....	28
Evaporative Cooler Equipped Units (Optional).....	28
Operation.....	29
General Information	29
Gas Controls System.....	29
Sequence of Operation.....	29
Optional Gas Controls.....	30
Air Handling Requirements and Adjustments	30
Lighting.....	32
Gas Input Adjustment.....	32
Pilot Adjustment.....	33
Primary Air Shutter Adjustment.....	33
Controls.....	33
Start-Up	35
Maintenance.....	37
High Limit and/or Safety Limit Maintenance.....	38

Seasonal Maintenance	38
Filters	38
Air Blower	39
Troubleshooting	41
Troubleshooting Guide — Air Blower	41
Troubleshooting Guide — Electric Motors	43
Troubleshooting Guide — Fan Assembly	45
Troubleshooting Guide — DX Cooling Coil	46
Troubleshooting Guide — Chilled Water Cooling Coil	47
Dimensional Data — Arrangements	48
Indoor Arrangement A, Capacity 50–80	48
Indoor Arrangement A, Capacity 12	49
Indoor Arrangement B, Capacity 10–40 (ships in one section)	50
Indoor Arrangement B, Capacity 50–80 (ships in two sections)	51
Indoor Arrangements D, Capacities 10–40 (ships in one section)	51
Indoor Arrangements D, Capacities 50–80 (ships in two sections)	52
Indoor Arrangements G, Capacities 20–40 (ships in one section)	53
Indoor Arrangements G, Capacities 50–12 (ships in two sections)	53
Indoor Arrangements K, Capacities 10–40 (ships in one section)	54
Indoor Arrangements K, Capacities 50–80 (ships in two sections)	54
Motor Electric Data	55
Approximate Motor Shipping Weights	56
Coil Cabinet Dimensional Data	58
Separated Combustion Indoor Make-Up Air Arrangements	59
Separated Combustion Indoor Make-Up Unit Number Description	60
Gas Equipment Start-Up	62



Receiving Instructions

Make-up Air Units with multiple furnaces are shipped in sections. Each section has a label with Order No., Model No., Unit No., and Part No. marked on it. Make certain that the order, model, and part numbers agree on each section to be connected together. Inspect shipment immediately when received to determine if any damage has occurred to the crate during shipment. After the unit has been uncrated, check for any visible damage to the unit. Check motor position and turn blower wheel to determine if damage has occurred to these critical parts. If any damage is found, the consignee should sign the bill of lading indicating such damage and immediately file claim for damage with transportation company.

Pre-Installation Instructions

Installer Please Note: This equipment has been test fired and inspected. It has been shipped free from defects from our factory. However, during shipment and installation, problems such as loose wires, leaks or loose fasteners may occur. It is the installer's responsibility to inspect and correct any problems that may be found. When the unit is received and uncrated, check the external data plate and all labels on the unit for type of gas, electrical, and operational specifications to confirm that these agree with those at point of installation. The unit is equipped with a Duct Furnace, also check the data plate and all labels located on each furnace. Every Make-Up Air unit will include an informational packet which will include the following: This make-up air manual, duct furnace and evaporative cooler/cooling coil manuals (if applicable to the unit order), wiring diagram(s), and special controls/data sheets.

Note: *It is the owner's responsibility to provide any scaffolding or other apparatus required to perform emergency service or annual/periodic maintenance to this equipment.*



General Safety Requirements

⚠ WARNING

Hazardous Service Procedures!

Failure to follow all precautions in this manual and on the tags, stickers, and labels could result in death or serious injury.

Technicians, in order to protect themselves from potential electrical, mechanical, and chemical hazards, **MUST** follow precautions in this manual and on the tags, stickers, and labels, as well as the following instructions: Unless specified otherwise, disconnect all electrical power including remote disconnect and discharge all energy storing devices such as capacitors before servicing. Follow proper lockout/tagout procedures to ensure the power can not be inadvertently energized. When necessary to work with live electrical components, have a qualified licensed electrician or other individual who has been trained in handling live electrical components perform these tasks.

- The use or storage of gasoline or other flammable vapors or liquids in open containers in the vicinity of this appliance is hazardous.
 - If you smell gas:
 - Do not touch electrical switches.
 - Extinguish any open flames.
 - Immediately call your gas supplier.
 - Open all disconnect switches before installing the unit. If the power disconnect is out of sight, lock it in the open position and tag it to prevent unexpected application of power. Failure to do so may result in personal injury or death from electrical shock.
 - Failure to comply with the general requirements may result in extensive property damage, severe personal injury or death.
 - Never service any component without first disconnecting all electrical and gas supplies to the unit or severe personal injury or death may occur.
 - Do not alter the duct furnace in any way or damage to the unit, severe personal injury or death will occur.
 - Do not attempt to convert the heater for use with a fuel other than the one intended. Such conversion is dangerous, as it could create unsafe conditions that result in death, serious injury or substantial property damage.
 - Do not depend upon a thermostat or other switch as the sole means of disconnecting power when installing or servicing heater. Always disconnect power at main circuit breaker as described above. Failure to do so could result in fatal electric shock.
1. Installation must be made in accordance with local codes, or in absence of local codes, with the latest edition of ANSI Standard Z223.1 (N.F.P.A. No 54) National Fuel Gas Code. All ANSI and NFPA Standards referred to in these installation instructions are the ones that were applicable at the time the design of this appliance was certified. The ANSI Standards are available from the National Standards Institute, Inc., 11 West 42nd Street, New York, NY 10036 or www.ansi.org. The NFPA Standards are available from the National Fire Protection Association, Batterymarch Park, Quincy, Massachusetts 02269. The heaters are designed for use in airplane hangers when installed in accordance with ANSI/NFPA No. 409 and in public garages when installed in accordance with the NFPA No. 88A and NFPA No. 88B.
 2. If installed in Canada, the installation must conform with local building codes, or in the absence of local building codes, with the current CGA-B149.1 or B149.2 "Installation Codes for Gas Burning Appliances and Equipment". These indoor duct furnaces have been designed for and certified to comply with CGA 2.6.
 3. No alterations are to be made on this equipment.
The duct furnace section of these make-up air units are certified by the American Gas Association for use with natural and LP (propane) gases!
 4. Make certain that the power sources conform to the requirements of the heater.



General Safety Requirements

5. Follow installation instructions CAREFULLY to avoid creating unsafe conditions. All wiring should be done and checked by a qualified electrician, using copper wire only. All gas connections should be made and leak-tested by a suitably qualified individual, per instructions in this manual.
6. Use only the fuel for which the heater is designed (see nameplate). Using LP gas in a heater that requires natural gas, or vice versa, will create the risk of gas leaks, carbon monoxide poisoning and explosion.
7. Make certain that power source conforms to electrical requirements of heater. Disconnect power before installing or servicing heater. If power disconnect is out of sight, lock it in open position and tag it to prevent unexpected application of power. Failure to do so could result in fatal electric shock.
8. Special attention must be given to any grounding information pertaining to this heater. To prevent the risk of electrocution, the heater must be securely and adequately grounded. This should be accomplished by connecting a grounded conductor from the service panel to the conduit box of the heater. To ensure proper ground, the grounding means must be tested by qualified field electrician.
9. Do not insert fingers or foreign objects into the heater or its air moving device. Do not block or tamper with the heater in any manner while in operation or just after it has been turned off, as some parts may be hot enough to cause injury.
10. This heater is intended for general heating applications ONLY. It must NOT be used in potentially dangerous locations such as flammable explosive, chemical-laden or wet atmospheres.

In cases in which property damage may result from malfunction of the heater, a backup system or a temperature sensitive alarm should be used.

⚠ WARNING

Fire Hazard and Toxic Fumes!

Failure to follow instructions below could result in death or serious injury.

The open end of piping systems being purged must NOT discharge into areas where there are sources of ignition or into confined spaces UNLESS precautions are taken as follows:

- **By ventilation of the space.**
- **By controlling the purging rate.**
- **By eliminating all hazardous conditions**

Unless otherwise specified, the following conversions may be used for calculating SI unit measurements:

- 1 inch = 25.4 mm
- 1 foot = 0.305 m
- 1 gallon = 3.785 L
- 1 pound = 0.454 kg
- 1 psig = 6.894 kPa
- 1 cubic foot = 0.028 m³
- 1000 Btu/Cu. Ft. = 37.5 MJ/m³
- 1000 Btu per hour = 0.293 kW
- 1 inch water column = 0.249 kPa
- liter/second = CFM × 0.472
- meter/second = FPM ÷ 196.8

Location

Before placing the Make-Up Air unit in its permanent location, make certain that the structure is capable of carrying the additional load of this equipment. Check the unit weight given at the end of this manual.

Note: Refer to unit data plate for required clearances to combustibile material, and [Figure 15, p. 22](#) in the "Installation" chapter for manufacturer's recommendations.

⚠ WARNING

Proper Installation Location Required!

Failure to follow instructions below could result in death or serious injury.
Do not place unit in a location where service personnel can not safely service this equipment (i.e. roof edge, skylights, etc.).

Important:

- When selecting a location for these Make-Up Air Units, both the size of the unit and the heating requirements of the building must be considered.
- The furnace section(s) of this unit is equipped for bottom access serviceability only! Provide adequate clearance (base rail to floor is 18 inches minimum).
- If a variable frequency drive (VFD) has been ordered with the unit, consideration should be made for the VFD operating temperature range: 14°F to 130°F. For temperatures below 14°F, VFD must be factory-installed within the VFD Enclosure accessory (Model Digit 22, option 9), or field-mounted indoors.

Combustion Air Considerations

The presence of chlorine vapors or other corrosive vapors in the combustion air supply for gas-fired heating equipment presents a potential corrosive hazard. Chlorine will, when exposed to flame, precipitate from the compound (usually freon or degreaser vapors) and go into solution with any condensation that is present in the heat exchanger or associated parts. The result is hydrochloric acid which will readily attack all metals, including 300 grade stainless steel. Care should be taken to separate these vapors from the combustion process.

Locations to Avoid

NOTICE

Heat Exchanger Damage!

Failure to follow instructions could result in damage to the heat exchanger and void the warranty.

Do not locate any gas fired heater where air for combustion contains impurities such as chlorinated vapors or acid fumes. Avoid locations where extreme drafts can affect burner operation.

Unit heaters should not be installed within corrosive or flammable atmospheres. Do not locate any gas fired heater where air for combustion contains chlorinated vapors or acid fumes.

Important: The venting system must be installed in accordance with heater manufacturer's instructions. The venting system is an integral part of the unit and must not be altered in the field!

Mounting Height

1. When a Gas Fired Make-Up Air Handler is discharging directly into the heated space, a mounting height of eight feet (2.4m) above the floor is recommended. Less efficient air distribution results at higher levels.
2. When Gas Fired Indoor Make-Up Air Handlers are installed in airplane hangars, NFPA specifies that the units must be at least ten feet (3.0m) above the upper surface of wings or engine enclosures of the highest aircraft to be stored in the hangar. This measurement



General Safety Requirements

should be made from the wing or engine enclosure (whichever is higher from the floor) to the bottom of the heater. Heaters must be installed at least eight feet (2.4m) above the floor in shops, offices, and other sections of the hangar where aircraft are not stored or housed. Refer to NFPA 409 Aircraft Hangars.

3. In parking structures, Gas Fired Indoor Make-Up Air Handlers must be installed so that the burner flames are located 18" (457mm) above the floor or protected by a partition not less than 18" (457mm) high as specified in NFPA 88A Parking Structures.
4. In public repair garages, Gas Fired Make-Up Air Handlers must be installed in a detached building or room separated from repair areas as specified in NFPA 88B Repair Garages.

Suspension and Rigging

⚠ WARNING

Heavy Object!

Failure to follow instructions below could result in unit dropping which could result in death or serious injury, and equipment or property-only damage.

Ensure that all the lifting equipment used is properly rated for the weight of the unit being lifted. Each of the cables (chains or slings), hooks, and shackles used to lift the unit must be capable of supporting the entire weight of the unit. Lifting cables (chains or slings) may not be of the same length. Adjust as necessary for even unit lift.

⚠ WARNING

Heavy Object!

Failure to follow instructions below could result in death or serious injury, and equipment damage.

Make certain that the structure to which the single, dual, triple furnace and air handler sections is to be mounted is capable of supporting its weight. Under no circumstances must the gas lines, the venting system, or the electrical conduit be used to support the heater; or should any other objects (i.e. ladder, person) lean against the heater, gas lines, venting system, or the electrical conduit for support.

The unit should never be lifted by any unit component other than the base rail assembly. Unit components other than base rail assembly are not designed to support the total weight and may break.

- Units can be set on field furnished supports/cradle with access available to furnace bottom section, or suspended by rod hangers from the sub-frame (and lifting brackets).
Important: Any unit that has a side base rail longer than 104" (2.6m) requires additional field furnished supports by a qualified installer. Refer to all dimensional data and center of gravity information in this manual. If further information is required, contact the manufacturer's technical service department.
- The unit must be hung level from side to side and front to back. It is recommended to use the (9/16" diameter) hanging holes in the skid rail, and 1/2" threaded rod or pipe, and/or whatever other supports may be required to adequately support the unit. A field supplied cradle or other means of support may also be required. The installer is responsible for determining adequate and safe suspension methods.
- Rig unit using either belt or cable slings. Use spreader bars to protect the top of the unit when it is lifted. Make sure all hardware used in the lifting/mounting process is tightened and secured.
- Refer to Figures 1 and 2 following this section for Single Furnace Make-Up Air Unit rigging requirements. Refer to Figures 3, 4 and 5 for Dual/Triple Furnace Make-Up Air Unit rigging requirements, which ships to the site in two sections (Figure 3 is the air handler section and 4 and 5 are the furnace sections.).
- On units with a total length of less than 104" (2642mm), excluding evaporative cooler, two holes are provided in the base rail on each side of the unit. Slide pipes beneath the unit through these holes and attach rigging to pipes for lifting the unit.

- On units with a total length of a 104" (2642mm) or greater, excluding evaporative cooler, lifting lugs/brackets attached to the base rail are provided. Once the unit is set in place these lifting brackets may be removed if required.
- Attach rigging to lugs/brackets for lifting the unit. For distance between lifting lugs/brackets and total unit lengths, refer to the *Dimensional Data* section of this manual.

Figure 1. Hoisting of Make-Up Air Unit (Single Furnace) Without Lifting Brackets

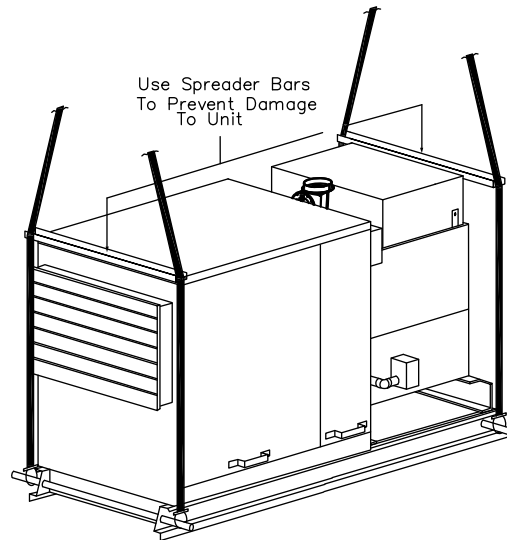


Figure 2. Hoisting of Make-Up Air Unit (Single Furnace) With Lifting Brackets

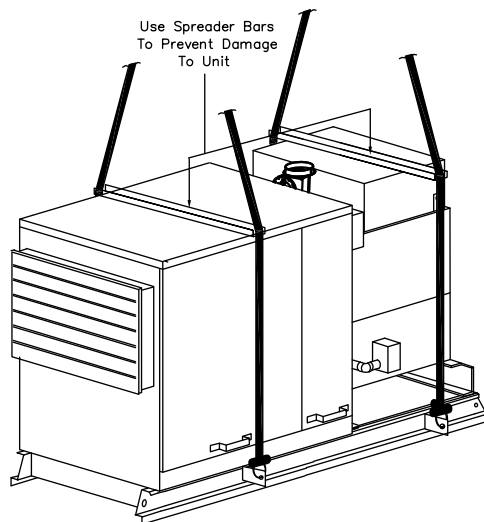


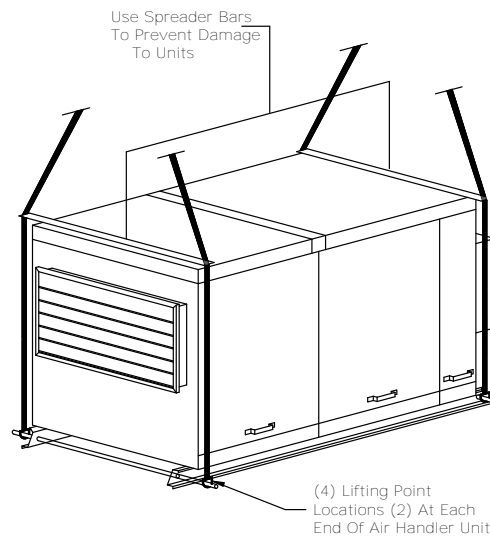
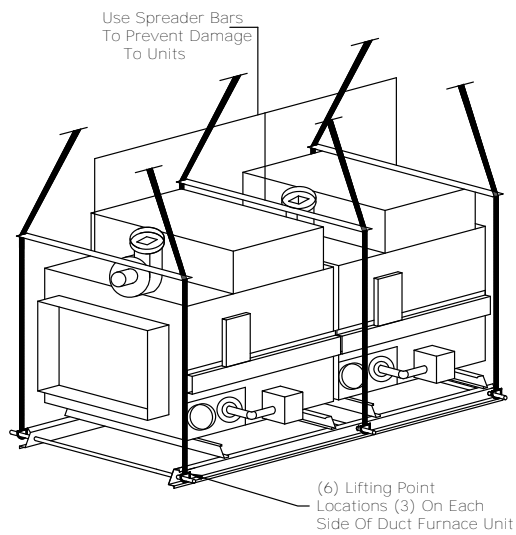
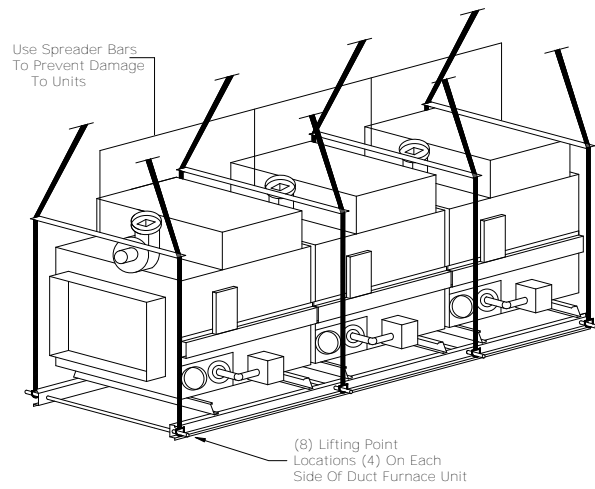
Figure 3. Hoisting Make-Up Air Handler Unit**Figure 4. Hoisting Double Furnace Unit**

Figure 5. Hoisting Triple Furnace Unit

Note: Refer to *Figure 3, p. 12, Figure 4, p. 12, and Figure 5, p. 13* for dual/triple furnace Make Up Air rigging requirements. Dual/triple furnace units ship to the site in two sections.



Installation

Note: Refer to all dimensional data within the manuals equipped with your unit.

Single Furnace Units

Single furnace units (capacities 10-40) consist of a furnace section and an air handler section mounted on a common base rail.

Multiple Furnace Units

Multiple furnace units consist of two sections: a furnace section with two duct furnaces (capacities 50-80) or three duct furnaces (capacity 12) mounted on a common base rail; and a separate air handler section mounted on its own base rail. A flexible connector kit is also equipped with your unit. Each section has a label with Order No., Model No., Unit No., and Part No. marked on it. Make certain that the order, model, and part numbers agree on each section to be connected together. The two sections should be moved individually and mounted in their permanent location (see "Suspension/Rigging" sections). Ensure that both flange assemblies are in alignment with a 5" (127mm) space between the flange assemblies. See the following instructions for installation of the flexible connector kit between the two sections.

Installing Flexible Connector

Note: Refer to Figure 6, p. 15, Figure 7, p. 16, Figure 8, p. 17, Figure 9, p. 18, Figure 10, p. 19.

1. Make sure that the furnace section and the air handler section are in alignment and installed with a 5" (127mm) space between the flange assemblies.
2. Remove the top extension panel of the duct furnace for access to the inside bottom flange assemblies.
3. Measure flexible connector in the flat to confirm that it is correct for the unit being installed. Refer to the Flexible Connector Kit Table following step #9. Make a 90 degree bend 4" (102mm) from one end of the flexible duct connector.
4. Measure the distance from the top of the flange assembly to the slot at the bottom of the flange assembly. Make a second 90 degree bend at the measured distance from the first bend in the flexible duct connector.
5. Slide the flexible connector through the slots in the flange assemblies until the vertical part is tight against the sides of the flange assemblies.
6. Bend second vertical section up around the flanges. Make sure all bends are straight and even for proper fit.
7. Bend down top section of flexible connector. Cut metal parts of flexible connector to overlap the 4 inch section by at least 1-1/2 inches (38mm), but cut the fabric portion 1-1/2 inches longer than the metal.
8. Screw metal portions of flexible connector to the flange assemblies using drill screws. Space the screws approximately 4 to 6" (102 to 152mm) on center. Fasten the bottom section in place by screwing down from the inside. Fasten the overlapped area with two screws in the metal on each side of the fabric. Seal the fabric joint with RTV sealer and allow to cure. Replace and reseal top extension panel on furnace section.
9. Apply sealing tape to seams between flanges and flexible connector and to vertical flange connections. Test for air leaks during initial start-up. Reseal as required.

Table 1. Flexible Connector Kit

Unit Capacity	(Approx.) Straight Length Flexible Connector Required
50	102 Inch (2.59m)
60	114 Inch (2.90m)

Table 1. Flexible Connector Kit (continued)

Unit Capacity	(Approx.) Straight Length Flexible Connector Required
70	124 Inch (3.15m)
80/12	135 Inch (3.43m)

Figure 6. Flexible Connector Kit Install

STEP 1

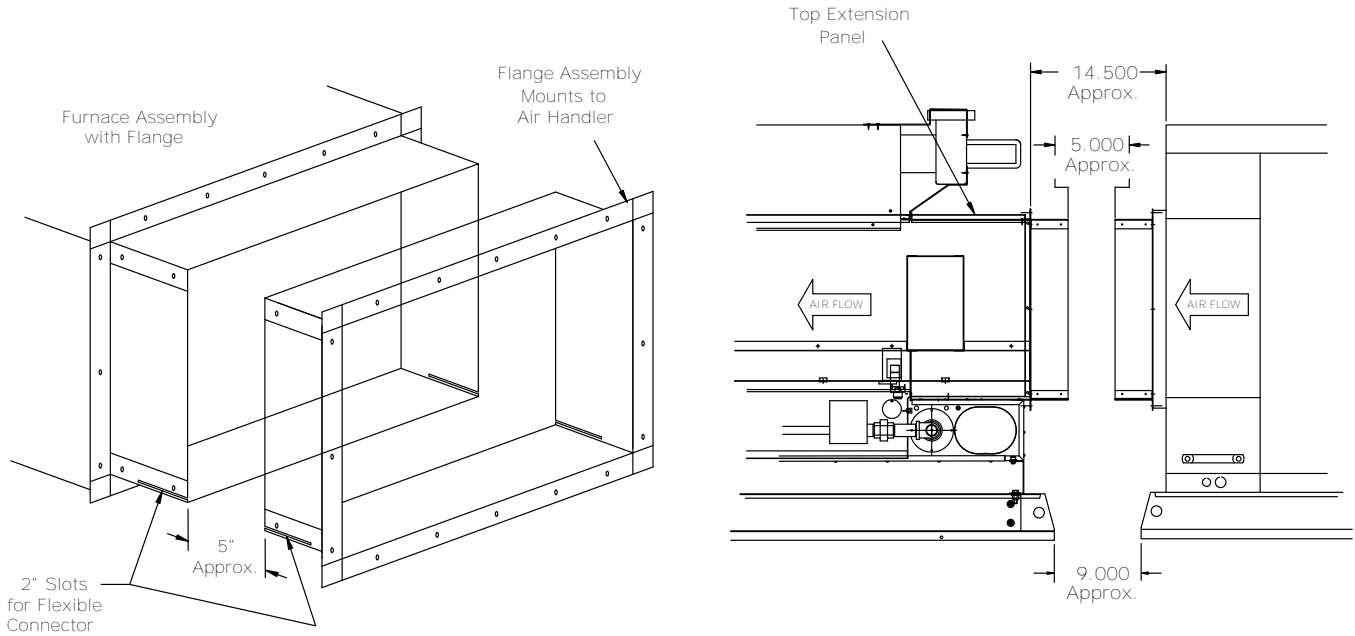


Figure 7. Flexible Connector Kit Install**STEP 2**

Remove Top Extension Panel of Duct Furnace to fasten Flexible Connector to bottom of the inside of Flange Assembly on both Furnace and Air Handler

Duct Furnace

1-1/2" Overlap sheet metal for proper installation

1-1/2" Overlap fabric for proper installation

STEP 3

Bend at approx. 4" on access side of unit

Bend at 90°

Slide Flexible Connector into place tightly before fastening

(4) Slots

STEP 4**STEP 5**

Figure 8. Flexible Connector Kit Install

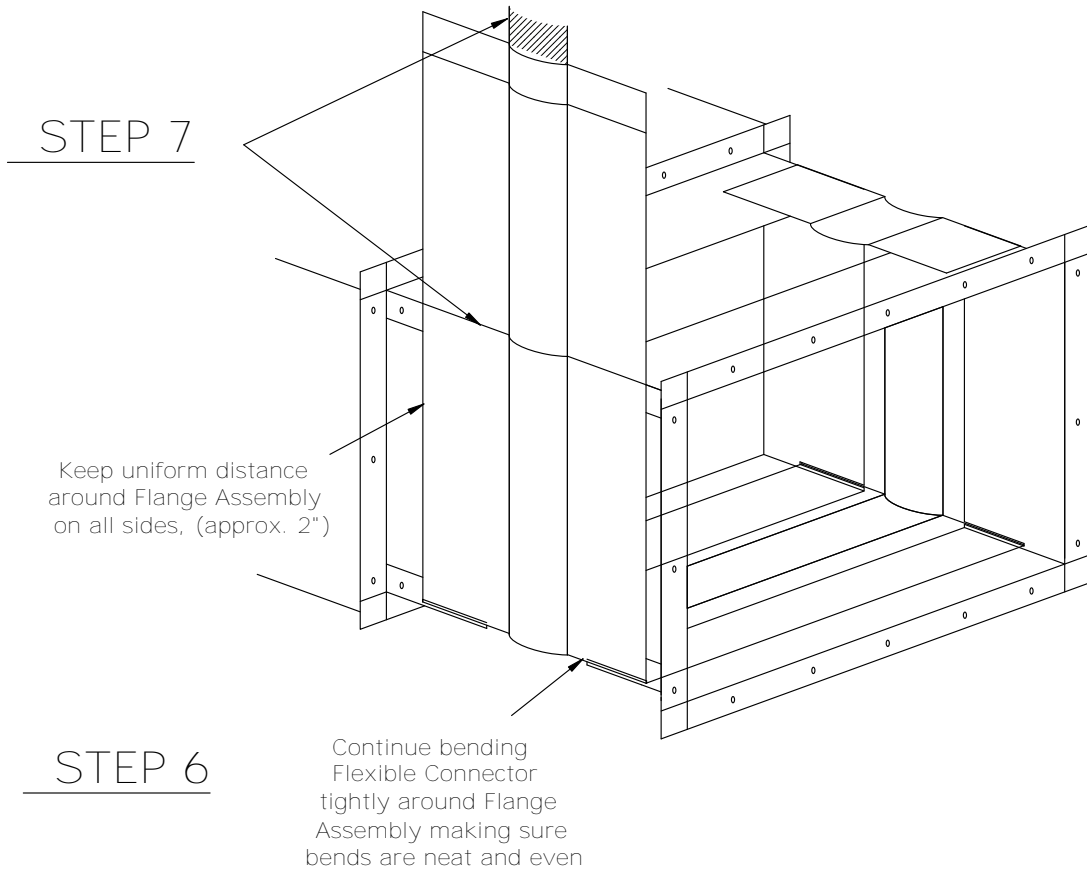
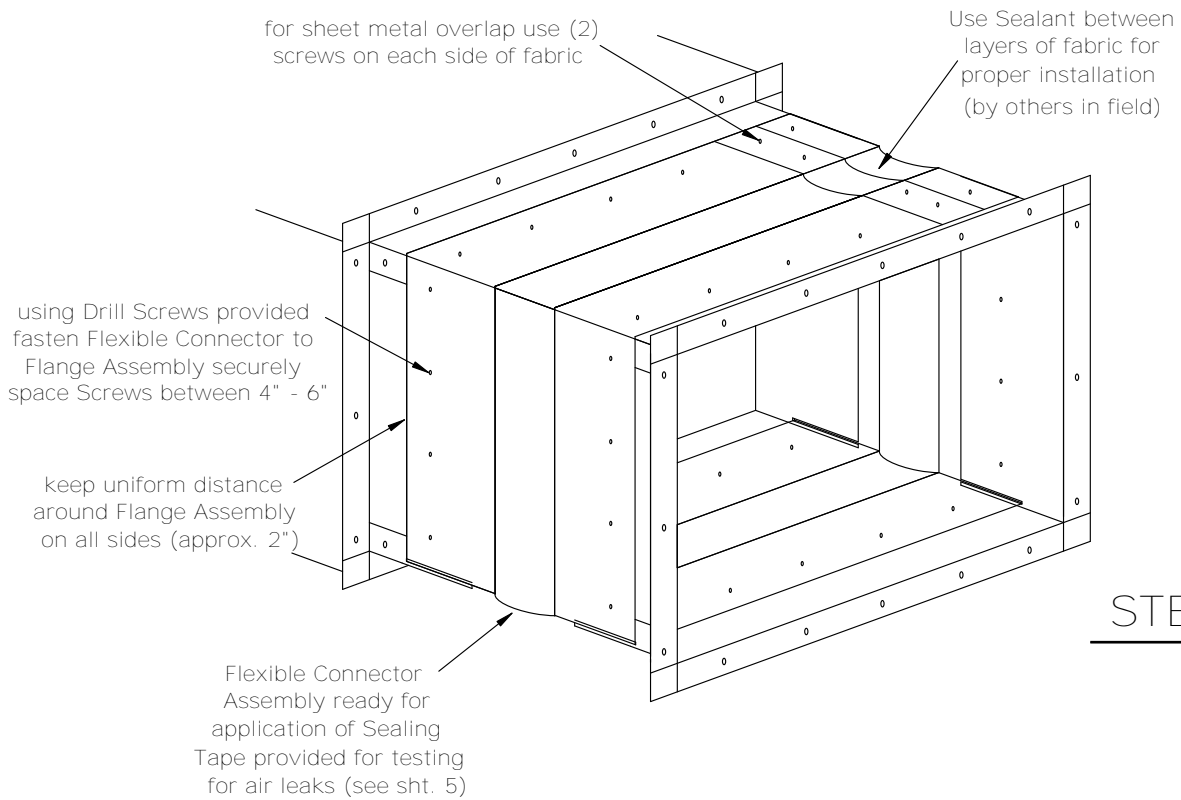
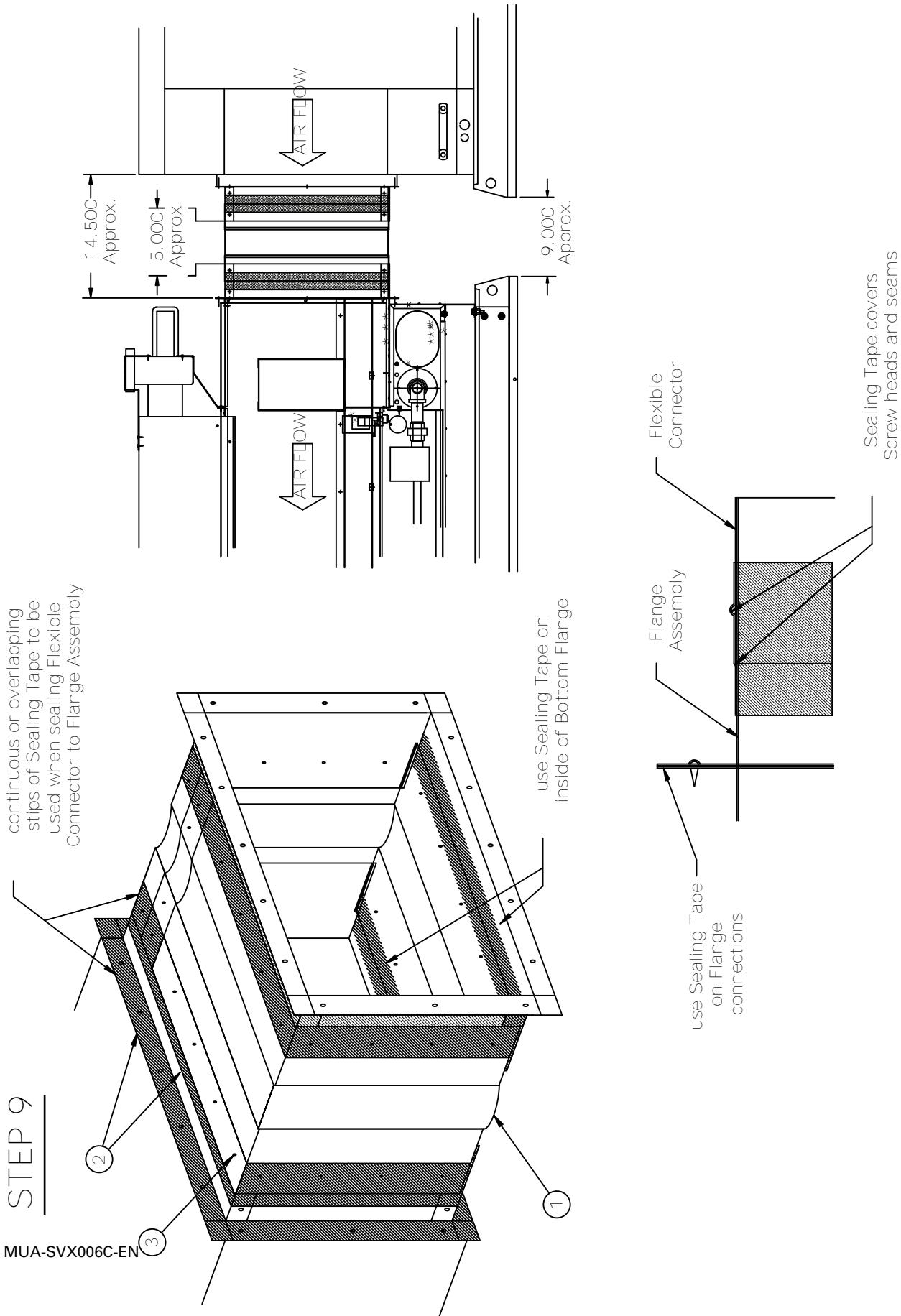


Figure 9. Flexible Connector Kit Install

STEP 8

Figure 10. Flexible Connector Kit Install





Installation Clearances

Minimum clearances to combustible material are shown on the unit data plate. It is important that clearances be maintained for servicing the unit, and that minimum clearances are provided from the unit to combustible material. Clearances around the field installed optional outside air hood (if unit is to be connected to one) must be unobstructed. See [Figure 15, p. 22](#).

⚠ WARNING

Combustible Materials!

Failure to maintain proper clearance between the unit and combustible materials could cause a fire which could result in death or serious injury or property damage. Refer to unit nameplate and installation instructions for proper clearances.

Every gas appliance should be located with respect to building construction and other equipment so as to permit access to the unit. Clearances between vertical walls and the vertical sides of the heater should be no less than 18" (457mm). Minimum clearance between the top of the heater and the ceiling is 6" (152mm). The minimum clearance to the bottom of the furnace is 25" (635mm). The minimum clearance from combustibles to the flue collector is 6" (152mm). The minimum clearance from combustibles to the vent pipe is 6" (152mm). See [Figure 15, p. 22](#).

*Note: *It is recommended that adequate clearance be kept to the bottom of the furnace(s) to make sure a service technician can safely service the unit(s),*

⚠ WARNING

Heavy Object!

Failure to follow instructions below could result in death or serious injury, and property damage.

The unit should never be lifted by the fan housing, motor mounting, grille or flue connection. These are not designed to support the total weight and may break.

⚠ WARNING

Heavy Object!

Failure to follow instructions below could result in unit dropping which could result in death or serious injury, and equipment or property-only damage.

Ensure that all the lifting equipment used is properly rated for the weight of the unit being lifted. Each of the cables (chains or slings), hooks, and shackles used to lift the unit must be capable of supporting the entire weight of the unit. Lifting cables (chains or slings) may not be of the same length. Adjust as necessary for even unit lift.

⚠ WARNING

Heavy Object!

Failure to follow these instructions could result in death, serious injury, and property damage.

Make certain that the lifting methods used to lift the duct furnace are capable of supporting the weight of the heater during installation. Ensure that all hardware used in the suspension of each duct furnace is properly rated for the job. Make certain that the structure to which the duct furnace is to be mounted is capable of safely supporting its weight. Under no circumstances must the gas lines, venting system, or the electrical conduit be used to support the duct furnace. Do not allow objects (i.e. ladder) or people to lean against the gas lines, venting system, or electrical conduit for support.

⚠ WARNING

Hazardous Voltage!
 Failure to disconnect power before servicing could result in death or serious injury. Disconnect all electric power, including remote disconnects before servicing. Follow proper lockout/tagout procedures to ensure the power can not be inadvertently energized. Verify that no power is present with a voltmeter.

⚠ WARNING

Risk of Unit Dropping!
 Failure to follow instructions below could result in death or serious injury, and equipment damage. Inspect the suspension and/or support system to ensure all fasteners are tight and the unit is secure before working underneath the unit.

Figure 11. Arrangement B & D, Capacities 10/40

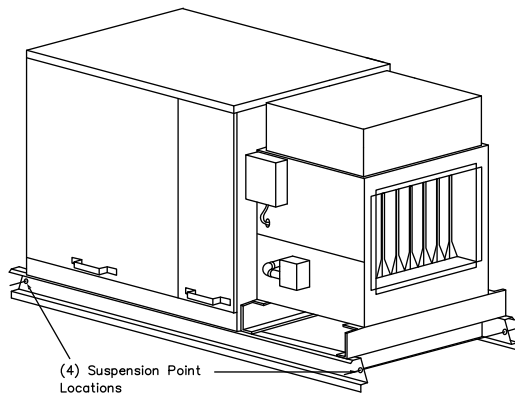


Figure 12. Arrangement G, Capacities 10/40

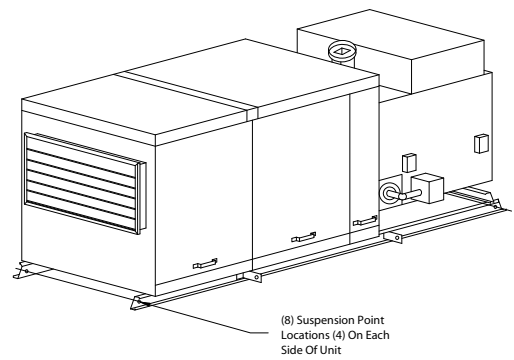


Figure 13. Arrangement G, Capacities 50/80

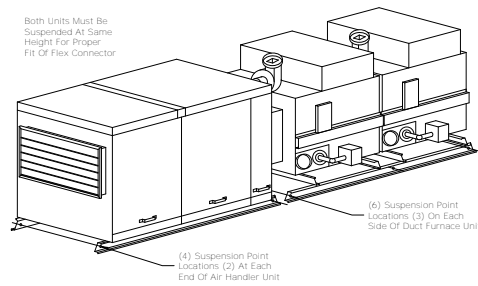


Figure 14. Arrangement G, Capacity 12

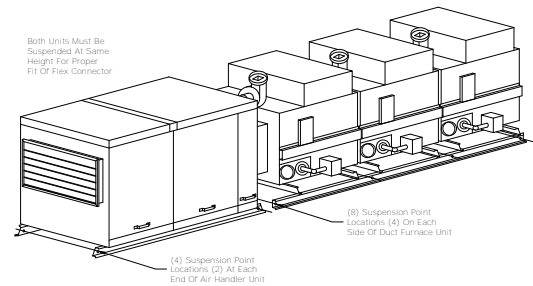
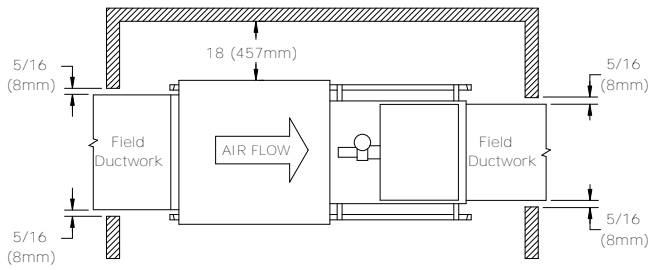
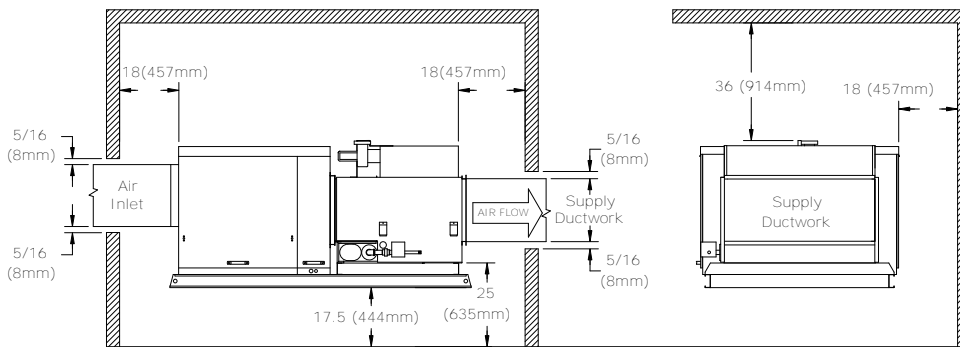


Figure 15. Manufacturer's Recommended Service Clearances



Note: Recommended ceiling clearance 36" (914mm) is to the top of the furnace venting collar assembly.



Venting†

All venting installations shall be in accordance with the latest edition of Part 7, "Venting of Equipment", of the National Fuel Gas Code, ANSI Z223.1 or applicable provisions of local building codes.

⚠ WARNING

Carbon Monoxide Poisoning!
 Failure to follow these instructions could result in Carbon Monoxide Poisoning (symptoms include grogginess, lethargy, inappropriate tiredness, or flu-like symptoms) which could result in death or serious injury.
 Never operate a unit without combustion air and flue gas piping in place. Each unit **MUST** have an individual vent pipe! Each unit **MUST NOT** be connected to other vent systems or to a chimney. Your venting system must not be blocked by any snow, snow drifts, or any foreign matter. Inspect your venting system to ensure adequate ventilation exists at all times!

⚠ WARNING

Proper Venting Required!
 Failure to follow instructions below could result in death or serious injury.
 All venting installations shall be in accordance with the National Fuel Gas Code, ANSI Z223.1 or applicable provisions of local building codes.
 Venting is an integral part of the unit and must **NOT** be altered in the field.

Note: †Refer to the Separated Combustion Indoor Duct Furnace Manual for more venting requirements.

Vent Systems Termination Clearance Requirements		
Structure/Object	Minimum Clearance for Termination Locations	
	USA	CANADA
Door, window, or gravity vent inlet; combustion air inlet for other appliances	9 inch for 10,000 to 50,000 BTU/Hr input; 12 inch for input exceeding 50,000 BTU/Hr.	9 inch (230mm) for 10,000 to 50,000 BTU/Hr input; 12 inch (305mm) for input exceeding 50,000 BTU/Hr.
Forced air inlet within 10 feet	3 feet above	6 feet (1.8m)
Adjoining Building or parapet	6 feet	6 feet (1.8m)
Adjacent public walkways	7 feet above grade	7 feet (2.1m) above grade
Electric, gas meters & regulators	4 feet horizontal	3 feet (0.9m) horizontally from meter/regulator assembly. 6 feet (1.8m), any direction, from a gas service regulator vent outlet
Above grade level*	1 foot*	1 foot (0.3m)*

Note: *If the vent terminal is to be installed near ground level, the vent terminal must be positioned at least six inches (152mm) above the maximum anticipated snow depth.

Duct Connections

All ductwork must be properly supported so that no strain is put on the unit. Do not alter or bend the discharge duct flanges supplied on your make-up air unit.

- Duct connections must have a removable access panel in the duct which is connected to a duct furnace. The duct openings shall be accessible when the unit is installed in service, and shall be of such size that smoke or reflected light may be observed inside the casing to indicate the presence of leaks in the heating element. The covers for the panels shall be attached in such a manner as to prevent leaks. Ducts (or optional outside air hoods) exposed to the outdoors must be insulated and sealed to prevent water from entering either the unit or building through the duct.
- If a single, double or triple duct furnace only unit is connected to a return air duct, or any other inlet air restriction, the appliance shall be installed on the positive pressure side of the air circulating blower.
- When connecting return air duct to Standard or High CFM cabinets, attach duct to return air opening flange when no dampers are used. Otherwise, if dampers are used, attach return air duct around collar at bottom of damper assembly. Also refer to the Dimensional Data section of this manual, Submittal Data Sheets and Indoor Duct Furnace Manual specified for your unit.

Gas Piping††

All gas piping must be installed in accordance with local codes. It is required that a ground union be installed adjacent to the gas valve of each duct furnace, and a ground union be installed just external of each duct furnace for unit servicing. On vertical runs, a drip leg should be provided upstream of any control manifold. A gas shutoff valve should be, or may be required by local codes, installed upstream of the external ground union for each duct furnace. A 1/8" N.P.T. plugged tapping, accessible for test gauge connection, must be installed immediately upstream of the unit gas supply connection.

⚠ WARNING**Fire Hazard and Toxic Fumes!**

Failure to follow instructions below could result in death or serious injury.

The open end of piping systems being purged must NOT discharge into areas where there are sources of ignition or into confined spaces UNLESS precautions are taken as follows:

- By ventilation of the space.
- By controlling the purging rate.
- By eliminating all hazardous conditions

⚠ WARNING**Fire Hazard!**

Failure to follow instructions below could result in damage to the unit gas valve and cause a fire hazard which could result in death or serious injury.

- Do NOT connect gas piping to this unit until a supply line pressure/ leak test has been completed.
- Do NOT rely on a gas shutoff valve to isolate the unit while conducting gas pressure/leak tests. These valves may not be completely shutoff, exposing the unit gas valve to excessive pressure.
- Do not over-tighten the inlet gas piping at unit gas valve.

⚠ WARNING**Explosion Hazard!**

Failure to follow safe leak test procedures below could result in death or serious injury or equipment or property-only-damage.

Never use an open flame to detect gas leaks. Use a leak test solution for leak testing.

Note: †† For complete Gas Piping installation, see the *Separated Combustion Indoor Gas-Fired Duct Furnace Installation and Service Manual*.

- The gas line should be supported so that no strain is placed on the unit. Pipe compounds which are not soluble to liquid petroleum gases must be used on threaded joints.
- The appliance and its individual shutoff valve must be disconnected from the gas supply piping system during any pressure testing of that system at test pressures in excess of 1/2 psig (3.5 kPa).
- The appliance must be isolated from the gas supply piping system by closing the individual manual shutoff valve during any pressure testing of the gas supply piping system at test pressures equal to or less than 1/2 psig (3.5 kPa).
- For additional gas piping information, including pipe sizing and drip leg installation, refer to *Separated Combustion Indoor Gas-Fired Duct Furnace Installation and Service Manual*.
- For additional piping information, refer to the National Fuel Gas Code Z233.1 (latest edition).
- Before any connection is made to an existing line supplying other gas appliances, contact the local gas company to make certain that the existing line is of adequate size to handle the combined load.
- Check all connections for leaks with soap solution.

Important: If the gas duct furnace is to be fired with LP gas, consult local LP gas dealer for piping size information.

Important: Unit installation for use with propane (bottled) gas must be made by a qualified LP gas dealer or installer. He will insure proper joint compounds are used for making pipe connections; that air is purged from lines; that a thorough test is made for leaks before operating the unit; and that it is properly connected to propane gas supply system.

Modulating Gas Control (Optional)*

Electronic: On units equipped with electronic modulating control, follow control manufacturer's installation instructions for sensing of outlet air temperature.

Note: *Also refer to the Separated Combustion Indoor Duct Furnace Installation Manual supplied with your unit.

Electrical Connections

⚠ WARNING

Hazardous Voltage!

Failure to disconnect power before servicing could result in death or serious injury. Disconnect all electric power, including remote disconnects before servicing. Follow proper lockout/tagout procedures to ensure the power can not be inadvertently energized. Verify that no power is present with a voltmeter.

- All electrical connections must conform to: the latest edition of ANSI/NFPA No. 70, National Electrical Code, and applicable local codes. In Canada, to the Canadian Electrical Code, Part I CSA Standard C22.1.

⚠ WARNING

Risk of Electrocutation!

Failure to follow instructions below could result in death or serious injury. DO NOT use any tools (i.e. screwdriver, pliers, etc.) across the terminals to check for power. You MUST use a CAT III or IV voltmeter rated per NFPA 70E.

- Single furnace make-up air packaged units are wired at the factory and are ready to be connected. Multiple furnace make-up air units are shipped in two parts, the air handler section and the furnace section. After mounting the two sections and installing the flexible duct connector, connect the free end of the flexible conduits from the air handler section to the junction box on the duct furnace. Each wire has a distinctive marking. Connect each wire to its respectively marked terminal in the duct furnace junction box. See [Figure 16, p. 26](#). Actual unit wiring will differ according to the options chosen. Each unit is shipped with its own wiring diagram; refer to this wiring diagram for all electrical connections to the unit.
- All line voltage and thermostat connections are made in the Electrical Cabinet (See [Figure 17, p. 27](#)). Line voltage connections are made at the High Voltage Terminal Block. Thermostat connections are made at the Main Connection Board (See [Figure 18, p. 27](#)).
- Locate the thermostat in accordance with the instructions supplied with the thermostat. All field wiring must have a minimum temperature rating of 185°F (85°C). Control wiring shall be a minimum of 18 gauge wire size. Control wiring must be sized for length of run.
- Locate line voltage disconnect box per local codes. If mounting the disconnect box to the unit, never mount it to a unit access panel. Possible locations include the front of the blower or filter section (See [Figure 19, p. 27](#)). Electrical conduit must be routed so as not to interfere with removal of any access panel.

⚠ WARNING**Fire Hazard!**

Failure to follow instructions below could cause a fire which could result in death or serious injury, and property damage.

DO NOT jumper factory wiring! Mis-wiring of safety circuits could cause a fire. For all wiring connections, refer to the wiring diagram shipped with the unit. Should any original wire supplied with the unit have to be replaced, it MUST be replaced with wiring material having a temperature rating of at least 221°F (105°C).

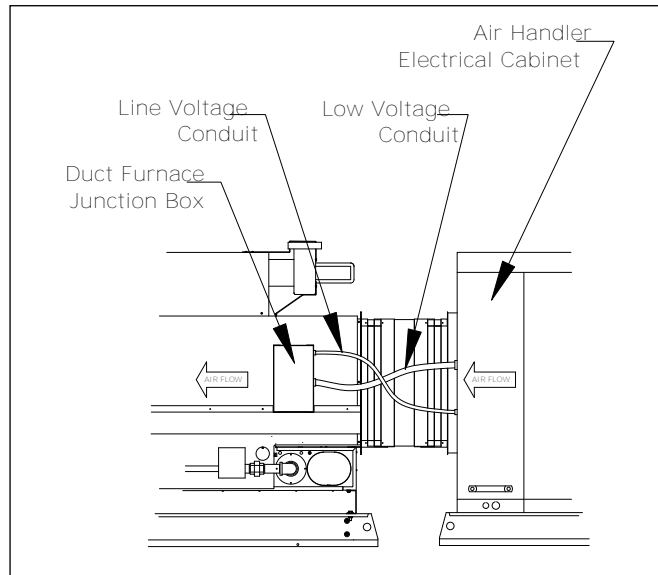
Figure 16. Wiring Connections

Figure 17. Make-Up Air Unit – Standard Blower Cabinet, Single Duct Furnace with Various Options Shown

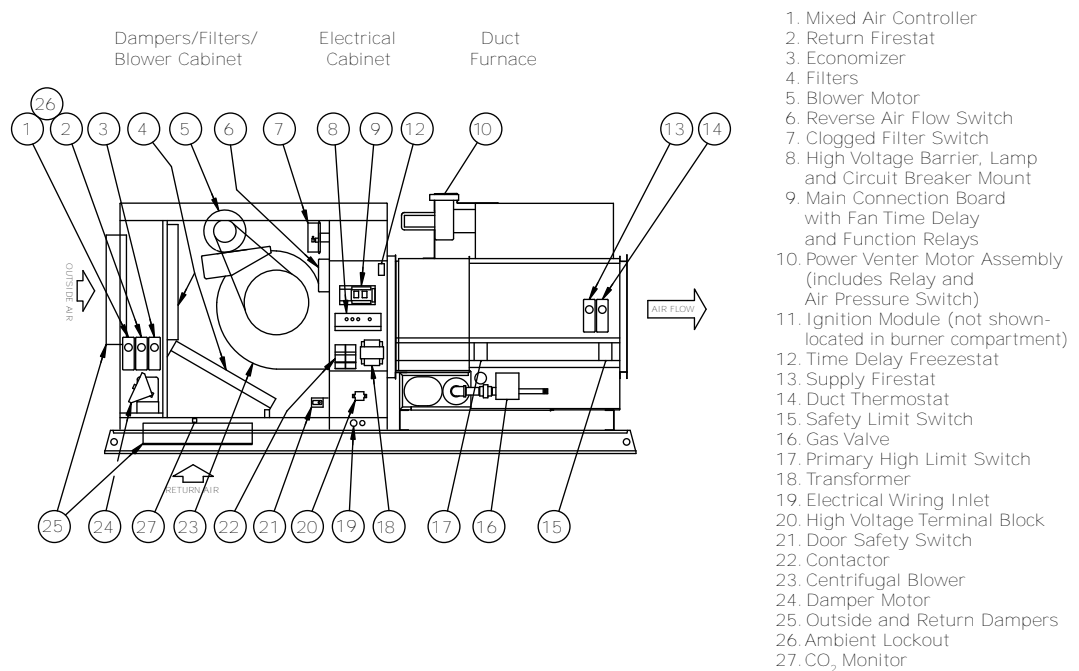


Figure 18. Electrical Cabinet

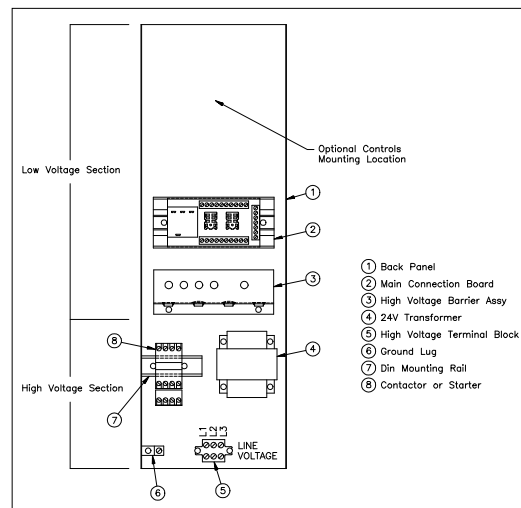
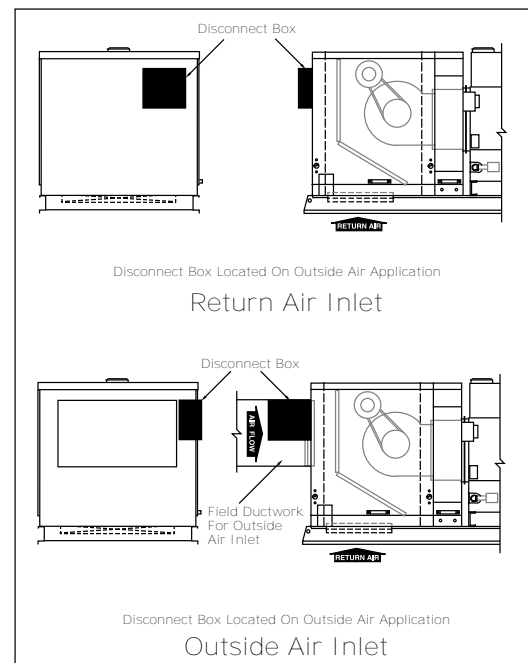


Figure 19. Disconnect Box Locations



DX Coil Equipped Units (Optional)

See *Coil Installation/Maintenance Manual* for Refrigerant Piping, Liquid and Suction Line Components, Refrigerant Charging and Thermal Expansion Valve Adjustment. Remove coil cabinet access door located next to blower section. Cut holes in fixed door to allow suction and liquid line passage. Provide weatherproof seal around suction and liquid lines at piping plate when installed.

- The DX Coil has a 300 ft/min. (1.524 m/s) minimum and a 600 ft/min. (3.048 m/s) maximum velocity through the coil requirement. This is due to prevention of coil icing or condensate blow-off. To calculate the velocity through the coil, apply the following formula:

$$\text{Velocity through the coil} = \frac{\text{Cooling Air Flow in CFM (m}^3\text{/s)}}{\text{Coil Surface Area in ft}^2\text{(m}^2\text{)}}$$

- Condensate Drain piping must have a P-trap in line immediately downstream of drain pan connection, external to the unit, to prevent possible outside air leakage into unit. The P-trap shall be of sufficient differential to overcome negative pressure of the indoor air blower. A minimum height difference of 2" (51mm) is required (See , p. 28). Before unit operation begins, the P-trap must be primed with either water (summer) or glycol (winter).

Chilled Water Coil Equipped Units (Optional)

See Coil Installation/Maintenance Manual for General Coil Piping Recommendations. Remove the coil cabinet door and cut holes in door to allow chilled water piping passage. Provide weatherproof seal around chilled water pipes at piping plate when installed.

The Chilled Water Coil has a 600 ft/min (3.048 m/s) maximum velocity through the coil requirement. This is due to prevention of condensate blow-off. To calculate the velocity through the coil apply the following formula:

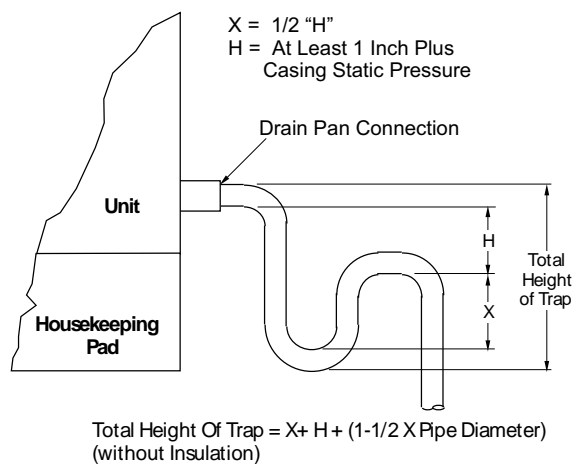
$$\text{Velocity through the coil} = \frac{\text{Cooling Air Flow in CFM (m}^3\text{/s)}}{\text{Coil Surface Area in ft}^2\text{(m}^2\text{)}}$$

Condensate Drain piping must have a P-trap in line immediately downstream of drain pan connection, external to the unit, to prevent possible outside air leakage into unit. The P-trap shall be of sufficient differential to overcome negative pressure of the indoor air blower. A minimum height difference of 2 inch is required (See , p. 28). Before unit operation begins, prime P-trap with either water (summer) or glycol (winter).

Evaporative Cooler Equipped Units (Optional)

Refer to Evaporative Cooler Installation and Service Manual for water and electrical connections.

Figure 20. Drain Pan Connection





Operation

General Information

Refer to Separated Combustion Indoor Gas-Fired Duct Furnace Installation and Service Manual for specific information regarding the heating operation of this unit.

All units are equipped with a intermittent pilot ignition system. The pilot is lit and extinguished each cycle of unit heating operation.

On natural gas units, the ignitor will continue to spark and pilot gas will continue to flow until the pilot flame is proven.

LP (propane) units are equipped with 100% lockout. The lockout function shuts off the main and pilot gas valves if the pilot gas fails to ignite within 90 seconds of the onset of trial for ignition.

The gas control system operates at 24 VAC and is supplied by a step-down transformer found in the electrical cabinet that will match the unit line voltage specified. See Figures 16 through 19 through for unit controls location.

Do not use a thermostatic fan control switch when either two-stage firing or modulated gas controls are used.

Gas Controls System

The standard unit comes equipped for single stage operation. Unit heating operation is accomplished at full input.

- Each duct furnace is equipped with an individual ignition control system which consists of the following components: ignition control module, gas valve and pilot burner.
- The **ignition control module** is the heart of the ignition control system. This control initiates all gas flow, provides means to light the pilot burner, proves and monitors the pilot burner operation.
- The **gas valve** consists of two operators which provide gas to the pilot and main burners. Both operators are energized and de-energized by the ignition control module each heating cycle.
- The **pilot burner** includes an ignitor and flame sense probe. The ignitor provides the spark, originating at the ignition control module, to light the pilot. The ignition control module proves and monitors the pilot flame through the flame sensing probe.

Sequence of Operation

All units follow the same basic sequence of operation and is as follows:

1. Thermostat calls for heat. Drafter relay energizes drafter with call for heat.
2. Pressure switch closes circuit to ignition control module.
3. Ignition control module energizes pilot operator of gas valve and initiates spark at ignitor of the pilot burner.
4. Pilot burner ignition is proven to the ignition control by the flame sense probe and sparking of the ignitor is discontinued.
5. Once pilot burner operation is proven, the ignition control module energizes the main burner operator of the gas valve, allowing gas flow to the main burners.
6. Approximately 60 seconds after the main burners light, the fan time delay initiates fan operation.
7. Thermostat is satisfied and call for heat is removed. Drafter relay de-energizes drafter with removal of call for heat.
8. Ignition control module de-energizes pilot and main burner operators of the gas valve, ceasing all gas flow.
9. Approximately two minutes after satisfying the thermostat, fan operation ceases.



Optional Gas Controls

These units are available with optional gas controls which will give either multi-stage or modulating operation. The sequence of operation of those units equipped with these optional gas controls differs only at what rate each duct furnace’s main burners ignite and operate at, or the order of duct furnace firing for those units equipped with two or three duct furnaces.

- **Two Stage Units:** Two stages of heating; first stage is 50% of full rate, second stage is 100% of full rate. Main burner ignition is at first stage only.
- **Three Stage Units:**
 - *Dual duct furnace models:* First furnace is equipped with two stage heating; second furnace is equipped with single stage heating but fired independently, giving three stages of heating.
 - *Triple duct furnace models:* Each duct furnace is equipped with single stage heating but fired independently, giving three stages. Each stage is 33% of the unit’s full input rate. Duct furnace one will always light first and disengage last.
- **Four Stage Units:** Dual duct furnace models only. Each duct furnace is equipped with two stage heating but fired independently, giving four stages. Each stage is 25% of the units full input rate. Duct furnace one will always light first and disengage last.
- **Six Stage Units:** Triple duct furnace models only. Each duct furnace is equipped with two stage heating but fired independently giving six stages. Each stage is 16.5% of the units full input rate. Duct furnace one will always light first and disengage last.
- **Electronic Modulation Units:** These units are equipped with an electronic modulating control which provides unit firing capabilities of 50 to 100% of the units full input rate. This control is found in the gas train downstream of the gas valve and allows main burner ignition only at the maximum rate. A thermostat with remote set point adjustment modulates the gas input.
- **Multi-Stage w/Electronic Modulation Units:** These dual and triple duct furnace models are equipped with an electronic modulating control on duct furnace one and single or two stage heating on each successive duct furnace. Furnace one (modulated) will fire first and disengage last. Additional stages of heat will engage after furnace one has fired at maximum modulation capability for the duration of the delay setting. The amount of modulation and each stage size depends upon unit size and the number of stages. See following chart.

Number of Stages	Modulation Capabilities (% of full input)	Stage Size (% of full input)
2	25 - 50	50
3	16.5 - 33	33
4	25 - 50	25
6	16.5 - 33	16.5

Air Handling Requirements and Adjustments

NOTICE

Unit Damage!

Failure to follow instructions below could result in unit damage.

Remove wooden shipping support from beneath blower housing of blower Section.

Static Pressure through the unit should never exceed 2.0 inch W.C. (0.50 kPa). The standard unit is operated at a temperature rise range of 20 to 60°F (11 to 33°C). The high temperature rise model is operated at a temperature rise range of 60 to 90°F (33 to 50°C).

Important: It is important that the final temperature leaving the unit does not exceed 160°F (71°C). When final air throughput adjustments are being made, a check of the discharge air temperature should be made after unit has operated for 15 to 20 minutes.

⚠ WARNING

Fire Hazard!

Failure to follow instructions below could result in death or serious injury, and property damage.

A unit should never be allowed to cycle on the primary limit for a prolonged period of time. It is a safety control to prevent a fire. If cycling on the primary limit is noted, corrective measures should be taken immediately.

Important: At initial unit installation, unit should be started momentarily to confirm proper blower wheel rotation as the unit will deliver some air with the blower wheel running backwards.

Two basic air control systems can be used to deliver conditioned air to the occupied space: intermittent or constant fan operation.

Intermittent Fan Operation: The unit employs an air control system which utilizes a fan time delay relay to operate the fan while heating and the thermostat while cooling. Refer to unit wiring diagram.

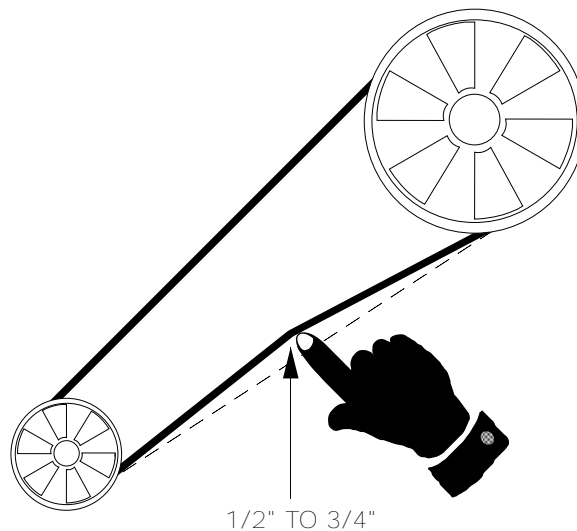
Constant Fan Operation: The unit can be wired to give an air control system which constantly circulates air through the unit and occupied space with constant fan operation. Refer to unit wiring diagram.

Important: Check blower belt tension. Proper belt tension is important to the long life of the belt and motor. Proper belt tension will allow the belt to be depressed 1/2 inch to 3/4 inch.

It is important that the blower motor and the blower wheel pulleys be in good alignment, with the motor and blower shafts parallel.

Belt tension must be adjusted to give approximately 3/4 inch deflection of the belt when finger pressure is applied to the middle of the belt (See [Figure 21, p. 31](#)). Small changes in this tension may be necessary for optimum operation. Belts will stretch over a period of time, requiring an adjustment to this tension. See Maintenance section for belt and pulley adjustments.

Figure 21. Belt Tension Guide



These units are set at the factory for the RPM required to meet the air volume (CFM) and external static pressure ordered. If the estimated external static is incorrect, or changes were made to the duct system, the blower RPM may need to be changed.

Both the Standard and High CFM Blowers use motors which are equipped with adjustable pitch pulleys. After removing belt(s), loosen the pulley set screw and remove the key, turn adjustable half of a pulley clockwise to increase RPM, or counter-clockwise to decrease RPM. Insert key,



tighten set screw and replace belt(s). Adjust belt tension to give 1/2 inch to 3/4 inch belt play when depressed.

NOTICE

Blower Motor Failure!

Failure to follow instructions below could result in improper unit operation and motor failure.

Blower motor full load amps should never be exceeded. Refer to motor data plate for maximum full load amps.

After changing blower RPM, confirm blower motor full load amps have not been exceeded. See motor data plate for maximum full load amps.

Lighting

Note: Refer to Separated Combustion Indoor Duct Furnace Manual for all heating functions - general comments are as follows.

Purge the gas line to the unit of air before attempting to light the pilot. Check for gas leaks.

⚠ WARNING

Explosion Hazard!

Failure to follow safe leak test procedures below could result in death or serious injury or equipment or property-only-damage.

Never use an open flame to detect gas leaks. Use a leak test solution for leak testing.

This unit is equipped with an intermittent ignition system. A lighting instruction is attached to the unit. To set the intermittent ignition system into operation proceed as follows:

1. Turn on the gas valve(s) main manual valve.
2. Turn on electrical power. The unit is now under thermostat control.
3. Set thermostat to highest level. This will initiate the sequence of operation detailed in the Gas Control System section. Check main burners for operation.
4. Set thermostat to lowest level. This will interrupt power to the ignition control and shut off gas. Confirm pilot and main burners have been extinguished.
5. Set the thermostat to the desired setting.

For complete unit shutdown, proceed as follows:

1. Turn off the gas valve(s) main manual valve.
2. Set thermostat to lowest setting.
3. Shut off all electric power.

Gas Input Adjustment

When shipped from the factory, all units are equipped for the average heat content of the gas which is stamped on the unit rating plate.

NOTICE

Heat Exchanger Damage!

Failure to follow instructions below could result in heat exchanger damage.

Heat content of gas varies by locality; check the gas input after installation of the unit to ensure proper input. Never exceed the input on the rating plate.

For an accurate input rate measurement the following meter method should be used to determine unit input rate. If the meter method is not possible, a manifold pressure check should be made.

Meter Method of Checking Input Rate

1. Obtain the heating value of the gas from the local utility or gas dealer. This should be in units of Btu/ft³ (MJ/m³).
2. Determine the gas flow rate as shown in the following example. EXAMPLE: Assume this unit has a input rate of 250,000 Btu/hr (73.2 kW) and the heating value of the gas is 1000 Btu/ft³ (37.3 MJ/m³).

$$\begin{aligned} \text{Gas Flow Rate} &= \frac{250,000 \text{ Btu/hr}}{1000 \text{ Btu/ft}^3 \times 60 \text{ min/hr}} \\ &= 4.17 \text{ ft}^3/\text{min} \end{aligned}$$

3. Before determining the gas flow rate to the unit, all other gas appliances connected to the same meter must be turned off.
4. Fire unit according to instructions.
5. After approximately 15 minutes of unit operation, determine volume of gas used in five minutes of unit operation. For the Example above the unit should use 4.17 ft³/min x 5 min or 20.8 ft³ (1.97 L/s x 5 min x 60 s/min = 591L) of gas. Minor input adjustments can be made by removing pressure regulator cap and turning regulator clockwise to increase input or counter clockwise to decrease input. Any appreciable adjustment in input rate should be made by reorificing.

Method to Check Manifold Pressure

1. Close the manual valve of unit gas valve.
2. Install a 1/8 inch pipe connection in the tapped hole provided in the gas valve body near outlet of the valve.
3. Attach manometer to 1/8 inch pipe connection by means of a rubber hose.
4. Fire unit according to instructions and observe the pressure and confirm it matches the unit manifold pressure from the unit rating plate.
5. Small variations in the manifold pressure can be made by means of the gas valve pressure regulator. Remove pressure regulator cap and turn regulator clockwise to increase pressure or counter-clockwise to decrease pressure.

Pilot Adjustment

1. Disconnect wire from terminal marked MV at gas valve.
2. Provide call for heat.
3. Pilot adjustment is found on the gas valve. Remove pilot adjustment cap.
4. Adjust the pilot screw to provide properly sized flame.
5. A proper pilot burner flame is a soft steady flame that envelopes 3/8 to 1/2 inch (9.5 to 12.7mm) of the flame sense probe tip.
6. Replace the pilot adjustment cap.
7. Reconnect wire to terminal MV.

Primary Air Shutter Adjustment

After the unit has been in operation for at least 15 minutes, adjust the primary air flow to the burners. Turn the friction-locked manually rotated air shutters clockwise to close, counter clockwise to open. For correct air adjustment, close the air shutter until yellow tips in the flame appear. Then open the air shutter to the point just beyond the position where yellow tipping disappears.

Controls

Note: Also see the *Indoor Duct Furnace Manual*



Primary Limit Control: The primary limit control is a factory installed component surface mounted in the inlet airstream at the end of the heat exchanger. When the temperature reaches the limit set point, normally caused by insufficient air throughput, all gas is shutoff. The limit control has an automatic reset and once the unit has cooled, it will reset itself. This is a safety control and if cycling on the primary limit is noted, corrective action must be taken. See unit wiring diagram for electrical location. This control must never be bypassed. Upon completion of unit installation, the primary limit must be checked for proper operation. This can be accomplished by removing power to the indoor air blower and a call for heat.

Clogged Filter Switch:(Optional) The clogged filter switch monitors the pressure differential across the air filters. If this pressure differential becomes too great, the switch will alert of this condition. At this point the air filters must either be cleaned or replaced. The switch will reset itself.

Firestat: (Optional) Located in either the return airstream, the supply airstream, or both, this control monitors temperatures with set points which are field adjustable. If the temperature exceeds the set point, the control will cease unit operation. To resume unit operation, a manual reset of this control is required.

Freezestat: (Optional) Located in either the return airstream, the supply airstream, or both, this control monitors temperatures with set points which are field adjustable. If the temperature does not exceed the set point, the control will cease unit operation.



Start-Up

Before starting the unit, use the "Gas Equipment Start Up Sheet" (located at the end of this manual) and read the Separated Combustion Indoor Duct Furnace Manual entirely in conjunction with the procedures outlined below to ensure that the unit is completely and properly installed and ready for start up.

⚠ WARNING

Check of Safety Devices Required!
Failure to do follow instructions below could cause unsafe conditions and result in death, serious injury or property damage.
All safety controls MUST be checked before starting the unit and during regular maintenance! Check and test the operational functions of all safety devices supplied with this unit.

1. Inspect all wiring connections; connections should be clean and tight. **Trace circuits to insure that actual wiring agrees with the "as wired" diagrams provided with the unit.** Information in the wiring diagram title block should match the data appearing on the unit nameplate.
2. Lubricate all electrical motors according to the manufacturer's recommendations.
3. Verify that the system switch is in the OFF position.
4. Check unit supply voltage to ensure that it is within the utilization range.
5. Inspect the interior of the unit; remove any debris or tools which may be present.

Starting the Unit in Heating Mode

1. Close the unit disconnect switch which provides power to the unit.

***Important:** High voltage is present in some areas of the unit (primarily the main electrical cabinet) with the unit disconnect switch closed. Failure to exercise caution when working in the presence of energized electrical components may result in injury or death from electrical shock.*

⚠ WARNING

Live Electrical Components!
Failure to follow all electrical safety precautions when exposed to live electrical components could result in death or serious injury.
When it is necessary to work with live electrical components, have a qualified licensed electrician or other individual who has been properly trained in handling live electrical components perform these tasks.

2. Set the thermostat/switching subbase as indicated below:
 - a. Position the heating system switch at either HEAT or AUTO;
 - b. Set the fan switch to AUTO.
3. Place the system switch in the ON position.

***Note:** With the thermostat calling for heat, unit operation is automatic.*

Starting Unit in Cooling Mode

1. Close the unit disconnect switch which provides power to the unit.

***Important:** High voltage is present in some areas of the unit (primarily the main electrical cabinet) with the unit disconnect switch closed. Failure to exercise caution when working in the presence of energized electrical components may result in injury or death from electrical shock.*

2. Set the thermostat/switching subbase as indicated below:
 - a. Position the cooling system switch at either COOL or AUTO;
 - b. Set the fan switch to AUTO.



Start-Up

3. Place the system switch in the ON position.

Note: *With the thermostat calling for cooling, unit operation is automatic.*

Final Checkout

Run the unit sequentially through its stages of heating and cooling. Once proper unit operation is verified, perform these final steps:

1. Inspect unit for debris and/or misplaced tools and hardware.
2. Be sure all gas valves and controls are in the operating position if the unit will be operating immediately.
3. Cycle unit on all safety controls to verify proper unit operation.
4. Confirm proper operating control (thermostat or ductstat) operation by cycling unit.
5. Secure all exterior panels in place.



Maintenance

⚠ WARNING

Hazardous Voltage!

Failure to disconnect power before servicing could result in death or serious injury. Disconnect all electric power, including remote disconnects before servicing. Follow proper lockout/tagout procedures to ensure the power can not be inadvertently energized. Verify that no power is present with a voltmeter.

⚠ WARNING

Check of Safety Devices Required!

Failure to do follow instructions below could cause unsafe conditions and result in death, serious injury or property damage.

All safety controls **MUST** be checked before starting the unit and during regular maintenance! Check and test the operational functions of all safety devices supplied with this unit.

⚠ WARNING

Heavy Object!

Failure to inspect the suspension could result in death or serious injury, and equipment damage.

Inspect the suspension and/or support system for the make-up air unit to ensure that all fasteners are tight and the unit is secure before working underneath the unit.

- To check gas tightness of the safety shut-off valves, turn off the manual valve upstream of the appliance combination control. Remove the 1/8" pipe plug on the inlet side of the combination control and connect a manometer to that tapping. Turn the manual valve on to apply pressure to the combination control. Note the pressure reading on the manometer, then turn the valve off. A loss of pressure indicates a leak. If a leak is detected, use a soap solution to check all threaded connections. If no leak is found, combination control is faulty and must be replaced before putting appliance back in service.
Note: Gas tightness of the safety shutoff valves must be checked on at least an annual basis.
- These units have been developed for indoor installation. Maintenance is required and it is suggested that the following unit servicing and inspections be performed routinely. Also read in entirety and refer to the Separated Combustion Indoor Duct Furnace Manual for maintenance requirements.
- Inspect area near unit to be sure that there is no combustible material located within the minimum clearance requirements (see [Figure 15, p. 22](#)). Service panels provide easy access to the blower compartment and the electrical cabinet. To remove the service door from any of these compartments, refer to access panel removal section in beginning of this manual.

⚠ WARNING

Combustible Materials!

Failure to maintain proper clearance between the unit and combustible materials could cause a fire which could result in death or serious injury or property damage.

Refer to unit nameplate and installation instructions for proper clearances.

1. Follow the instructions in the maintenance section of the of the Separated Combustion Indoor Duct Furnace manual for servicing the furnace section of the make-up air unit.
2. Inspect and service the blower section of the system.
3. Inspect and check the operational functions of all safety devices equipped with your unit to ensure that all devices are performing adequately.



High Limit and/or Safety Limit Maintenance

Single furnace units are equipped with a primary high limit on the upstream side of the heat exchanger and a secondary high limit on the downstream side of the heat exchanger. Multiple furnace units are equipped with a primary high limit on each furnace section and a secondary high limit on the downstream unit. The primary high limit is a disk type switch while the secondary high limit is a capillary switch. To service or replace high limit or safety limit:

1. Turn off the manual gas valve and electrical power to the MS unit.
2. To access the high limits, remove the four screws from the top of the raceway on each furnace section and swing the raceway down. The primary limit can be removed by removing the two screws holding the high limit bracket to the heat exchanger and removing the bracket and limit assembly from the heat exchanger. Note location of and remove wires from limit switch, then remove push nuts and springs holding limit switch to bracket. Re-assemble in reverse order making sure that parts are assembled so that spring pressure holds limit switch securely against bottom header plate of heat exchanger.
3. To remove the secondary high limit, remove the wires from the limit switch, remove the screws and stand-off sleeves holding the limit switch body to the mounting plate. **Do not remove the screws holding the mounting plate to the heat exchanger.** Slowly pull the switch and capillary assembly out of the retaining tube, taking care to prevent kinking the capillary tube. Re-assemble in reverse order, carefully pushing the capillary tube into the retaining tube to prevent kinking the capillary tube.
4. Complete appropriate start-up procedure as given in the "Start-Up" section of this manual.
5. Check Burner Adjustment.
6. Check gas control valves and pipe connection for leaks.
7. Check operation of auto gas valve.
8. Check operation of safety devices.
9. Inspect and service blower section of system.

Seasonal Maintenance

The unit should be thoroughly checked before the start and at the end of each heating and cooling season.

1. Motors and belts should be inspected.
2. Tighten belts if loose.
3. Check and clean DX or Chilled Water coil twice yearly, if unit is so equipped per manufacturer's service manual. Chilled Water coil must be winterized at beginning of heating season (i.e. drain water from coil per manufacturer's instructions).
4. Check air throughput at beginning of heating season to confirm unit operation is within the specified temperature rise range.
5. At beginning of heating season clear Condensate Drain Pan and P-trap of water if unit is equipped with DX or Chilled water coil. Clean out drain pan and fill P-trap with a non-toxic glycol solution.
6. Evaporative cooler must be cleaned and maintained per manufacturer's instruction frequently during the operating season.
7. Inspect Control Dampers during periodic maintenance. Damper pivot points should be cleaned to ensure free damper operation.
8. Blower wheels should be checked periodically for dirt build-up on blades. Clean as required.

Filters

The filter section has been designed to incorporate (as standard) one-inch washable filters. Other optional filter types are also available: two-inch washable throwaways; or one or two inch hi-efficiency 30% pleated filters.

- It is recommended that air filters be changed or cleaned at least four times a year. More frequent attention to filters is required if the air being handled by the unit is unusually dirty. Air flow reduction, caused by the dirty air filters, will increase the discharge air temperature and may cause unit cycling on the primary limit.
- Filters (by others) should be serviced regularly and changed or washed when necessary to maintain the required air throughput. In a dusty environment, filters may clog up in less than one month.

Table 2. Standard CFM Blower Air Filter Size Requirements

Unit Input	Number of Filters Required	
	16 x 20 (in)	20 x 20 (in)
100 MBtuh (29.3 kW)	4	
150 MBtuh (44.0 kW)	4	
200 MBtuh (58.6 kW)		4
250 MBtuh (73.2 kW)		4
300 MBtuh (87.9 kW)	4	2
350 MBtuh (102.6 kW)	4	2
400 MBtuh (117.2 kW)		6
500 MBtuh (146.5 kW)		4
600 MBtuh (175.8 kW)	4	2
700 MBtuh (205.1 kW)	4	2
800 MBtuh (234.4 kW)		6

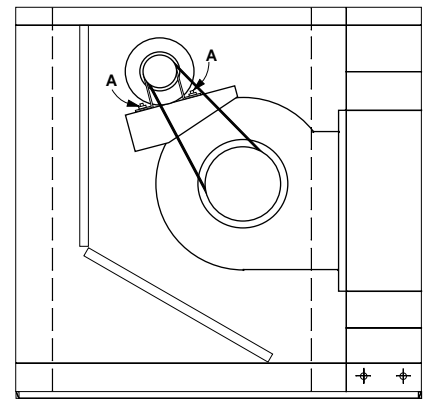


Figure 22. Standard CFM Blower

Table 3. High CFM Blower Air Filter Size Requirements

Unit Input	Number of Filters Required	
	16 x 20 (in)	20 x 20 (in)
100 MBtuh (58.6 kW)	8	
150 MBtuh (58.6 kW)	8	
200 MBtuh (58.6 kW)		8
250 MBtuh (73.2 kW)		8
300 MBtuh (87.9 kW)	8	4
350 MBtuh (102.6 kW)	8	4
400 MBtuh (117.2 kW)		12
500 MBtuh (146.5 kW)		8
600 MBtuh (175.8 kW)	8	4
700 MBtuh (205.1 kW)	8	4
800 MBtuh (234.4 kW)		12
1,200 MBtuh (351.6kW)		12

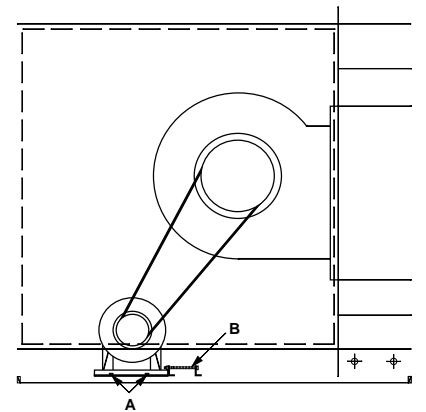


Figure 23. High CFM Blower

Air Blower

Belt Tension Adjustment

Note: Refer to Standard/High CFM Blower tables in the previous “Filters” section.

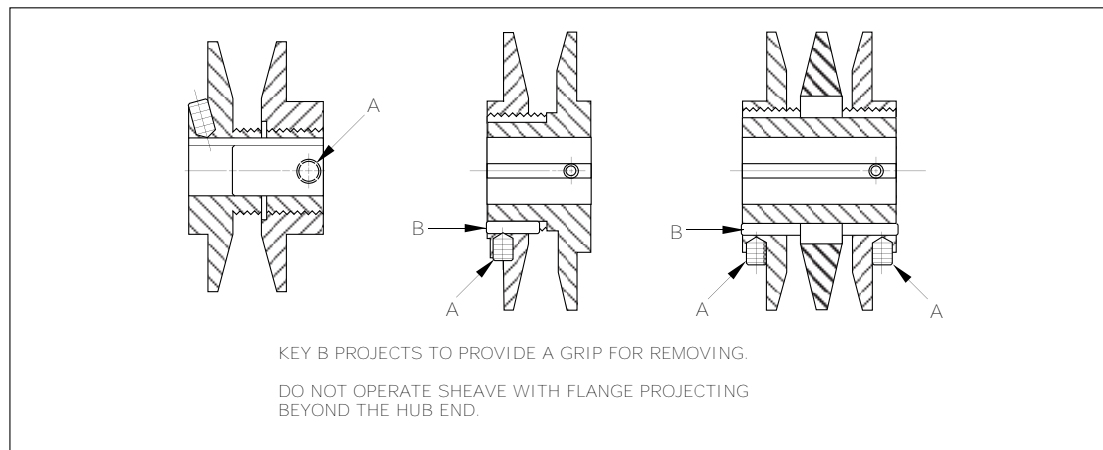
- Standard CFM Blower belt tension can be adjusted by loosening motor mounting bolts marked A. To tighten belt, slide motor down motor mounting bracket and re-fasten motor to mounting bracket.
- High CFM Blower belt(s) tension can be adjusted by first loosening motor mounting plate bolts marked A. To tighten belt tension, turn belt tension adjustment screws marked B counter-clockwise. To loosen belt tension, turn clockwise. Once belt tension has been adjusted, re-fasten motor mounting plate bolts.

Blower RPM Adjustment

To adjust blower RPM:

1. Loosen and remove belt(s).
2. Match driver pulley to one found in [Figure 24, p. 40](#).
3. Loosen setscrew(s) marked A.
4. If driver pulley is equipped with external key, marked B, remove.
5. Adjust driver pulley pitch diameter for desired speed by opening (slower) or closing (faster) moving parts by half or full turns. Do not open sheave past point where flange projects past the hub end.
6. If driver pulley is equipped with external key, marked B, replace.
7. Tighten setscrew(s) marked A.
8. Replace retention belt(s).
9. Realign drive if necessary.

Figure 24. Blower RPM Adjustment





Troubleshooting

For troubleshooting of the duct furnace, refer to the Separated Combustion Indoor Gas-Fired Duct Furnace Installation and Service Manual. For Evaporative Cooler/Cooling Coil equipped units, refer to these specific manuals for additional troubleshooting guides.

For additional troubleshooting, see following Troubleshooting Guide.

Troubleshooting Guide – Air Blower

Problem	Probable Cause	Solution
Noise	Blower Wheel Hitting Scroll Side	<ol style="list-style-type: none"> 1. Blower Wheel not centered in blower housing. 2. Damaged blower housing. 3. Damaged blower wheel. 4. Shaft loose in blower bearing. 5. Blower Wheel loose on shaft. 6. Blower bearing loose in bearing support.
	Blower Wheel Hitting Cutoff	<ol style="list-style-type: none"> 1. Cutoff not secure in blower housing. 2. Cutoff damaged. 3. Cutoff improperly positioned.
	Drive	<ol style="list-style-type: none"> 1. Pulley not tight on shaft (motor and/or blower wheel). 2. Belts too loose. Adjust for belt stretching after 48 hours of operation. 3. Belts too tight. 4. Belts wrong cross section. 5. Belts not matched in length on multi-belt drive. 6. Variable pitch pulleys not adjusted so each pulley has same pitch diameter (multi-belt drives). 7. Misaligned pulleys. 8. Belts worn. 9. Motor or motor base loose. 10. Belts oily or dirty 11. Improper drive selection
	Bearing	<ol style="list-style-type: none"> 1. Defective bearing. 2. Needs lubrication. 3. Loose on bearing support. 4. Loose on shaft. 5. Seals misaligned. 6. Foreign material in bearing. 7. Worn bearing. 8. Fretting corrosion between inner race and shaft.
	Shaft Seal Squeal	<ol style="list-style-type: none"> 1. Needs lubrication. 2. Misaligned.

Problem	Probable Cause	Solution
	Blower Wheel	<ol style="list-style-type: none"> 1. Loose on shaft 2. Defective blower wheel. Do not run blower. Contact manufacturer. 3. Unbalanced. 4. Worn as a result of contact with abrasive or corrosive material.
	Housing	<ol style="list-style-type: none"> 1. Foreign material in housing. 2. Cutoff of other part loose (rattling during operation).
	Electrical	<ol style="list-style-type: none"> 1. Lead-in cable not secure. 2. AC hum in motor or relay 3. Starting relay chatter. 4. Noisy motor bearings. 5. Single phasing a 3-phase motor.
	Shaft	<ol style="list-style-type: none"> 1. Bent. 2. Undersized. May cause noise at blower wheel, bearings or pulley. 3. If more than two bearings are on a shaft, they must be properly aligned.
	High Air Velocity	<ol style="list-style-type: none"> 1. Duct work too small for application. 2. Blower selection too small for application. 3. Registers or grilles too small for application. 4. Cooling coil with insufficient face area for application.
	Obstruction in High Velocity Air Stream may cause Rattle or Pure Tone Whistle	<ol style="list-style-type: none"> 1. Dampers. 2. Registers. 3. Grilles. 4. Sharp elbows. 5. Sudden expansion in duct work. 6. Sudden contraction in duct work. 7. Turning vanes.
	Pulsation or Surge	<ol style="list-style-type: none"> 1. Blower too large for application. 2. Ducts vibrate at same frequency as blower pulsations.
	Rattles and/or Rumbles	<ol style="list-style-type: none"> 1. Vibrating duct work. 2. Vibrating cabinet parts. 3. Vibrating parts not isolated from building.
CFM Low - Insufficient Air Flow	Blower	<ol style="list-style-type: none"> 1. Forward curved blower wheel installed backwards. 2. Blower operating backwards. 3. Cutoff missing or improperly installed. 4. Blower wheel RPM too low.

Problem	Probable Cause	Solution
	Duct System	<ol style="list-style-type: none"> 1. Actual system is more restrictive than expected. 2. Dampers closed. 3. Registers closed. 4. Leaks in supply duct.
	Filters	Dirty or clogged.
	Coil - DX or Chilled Water	Dirty or clogged.
	Obstructions in High Velocity Air Stream	<ol style="list-style-type: none"> 1. Obstruction near unit outlet. 2. Sharp elbows near unit outlet. 3. Improperly designed turning vanes. 4. Projections, dampers or other obstructions in part of duct system where air velocity is high.
CFM High - Too Much Air Flow	System	<ol style="list-style-type: none"> 1. Oversized duct work. 2. Access door open. 3. Registers or grilles not installed. 4. Filters not in place. 5. System resistance lower than anticipated.
	Blower	Blower RPM is too great.
Blower Does Not Operate	Installation	<ol style="list-style-type: none"> 1. Incorrect electrical connection. 2. Wrong voltage. 3. Blown fuse.
	Unit	<ol style="list-style-type: none"> 1. Broken belt(s). 2. Loose pulleys. 3. Power to unit is disconnected. 4. Motor overload protector has broken circuit. 5. Optional thermostats, firestats, freezestats may lockout blower operation if set incorrect.

Troubleshooting Guide – Electric Motors

Problem	Probable Cause	Solution
Motor	Blown fuse or open circuit breaker	Replace fuse or reset circuit breaker.
	Overload trip	Check and reset, if manual.
	Improper line connections	Check connections to unit wiring diagram.
	Improper current supply	Check to determine that power supply agrees with motor nameplate specifications.
	Mechanical failure.	Check bearings. Determine that motor and drive turn freely.

Problem	Probable Cause	Solution
	Motor overloaded	Reduce load or replace motor.
	With a 3 phase power source, one phase may be open	Check line for open phase.
	Defective capacitor	Replace capacitor.
Motor Stalls	Wrong application	Consult manufacturer.
	Overloaded motor	Reduce load or replace motor.
	Low line voltage.	Check across AC line and correct if possible.
Motor runs and then lies down	Partial loss of line voltage	Check for loose connections. Determine adequacy of main power supply.
Motor does not come up to speed	Motor undersized for application	Replace with larger motor.
	Voltage too low at motor terminals	Check across AC line and correct if possible.
	Line wiring to motor is too small	Install larger line wiring.
Motor takes too long to accelerate	Excessive load.	Replace with larger motor.
	Loose connection.	Check connections and tighten where necessary.
Wrong Rotation (3 Phase)	Improperly wired to AC line (wrong sequence of phases)	Check unit wiring diagram. Reverse any two line voltage connections.
Motor Overheats	Motor overloaded	Replace with larger motor.
	Motor ventilation clogged	Clean motor.
	Motor (3 phase) may have open phase	Check to insure that all connections are tight.
	Line voltage too high or too low	Check across AC line and correct if possible.
	Worn blower bearings.	Replace blower bearings.
Motor Vibrates	Motor mounting bolts loose	Tighten mounting bolts.
	Driven equipment unbalanced	Balance driven equipment.
	Worn motor bearings.	Replace motor.
	3 phase Motor running on single phase	Check for open circuit and correct.

Problem	Probable Cause	Solution
	Bent motor shaft	Replace motor.
Rapid Motor Bearing Wear	Excessive overhung load due to over-tensioned belt	Reduce belt tension.

Troubleshooting Guide – Fan Assembly

Problem	Probable Cause	Solution
Short Belt Life	Spin burns from belt slippage	Tension belt.
	High ambient temperature	Use Gripnotch belts.
	Grease or oil on belts	Clean belts and pulleys.
	Worn pulleys	Replace pulleys.
	Belt Misalignment	Realign drive.
Belts turn over in grooves	Damaged belt	Replace belt.
	Excessive vibration	Tension belts. Replace belts if damaged.
	Worn pulleys	Replace pulleys.
	Pulley Misalignment	Realign drive.
Belt Squeal	Excessive load	High starting load. Retension drive.
Belt Breakage	Foreign material in drive	Provide drive guard.
	Belts damaged during installation	Replace belts.
	Extreme Overload	Eliminate overload.
Excessive Vibration	Damaged belt cord section	Replace belts.
	Loose belts	Tension drive.
	Belts improperly tensioned	Tension drive with slack of each belt on the same side of drive.
Belts mismatched after service	Belts improperly tensioned, causing more stretch of some belts than others	Replace belts and tension drive with slack of each belt on the same side of the drive.
	Old belts and new belts used on same drive	Replace with new belts.
	Different brand name belts used on same drive	Replace with a set of machine-matched belts.

Problem	Probable Cause	Solution
	Driver and driven shafts shifted from parallel	Realign drive.
	Belt cord section damaged during installation	Replace belts and install properly.
Drive fails to adjust	Fretting corrosion (drive allowed to operate at one speed over a period of time)	Driver pulley must be disassembled, cleaned and lubricated, then reassembled.

Troubleshooting Guide – DX Cooling Coil

Problem	Probable Cause	Solution
No or Insufficient Cooling	Coil icing	1. Low liquid line pressure.* 2. Thermal expansion valve.** 3. Low air flow across coil.
	Air binding	Purge and charge system.
	Thermal expansion valve**	1. Bulb mounted at incorrect location. 2. Bulb not secured properly.
	Insufficient air flow	1. See air blower troubleshooting. 2. Clogged coil
	Air bypassing coil	Caulk safe off.
	Undersized system, demand exceeding cooling system capacity	Replace system.*
	Too much outside air	Check outside air dampers.
	Refrigerant leak	Determine leak location and correct.
	Low liquid pressure	Determine cause and correct.*
Water in Conditioned Air	Exceeding coil face velocity - 600 fpm.	Reduce unit air flow.
	Drain pan p-trap clogged.	Clean pan and p-trap.

Note: *Refer to condensing unit installation and service manual.
**Refer to thermal expansion valve installation instruction.

Troubleshooting Guide – Chilled Water Cooling Coil

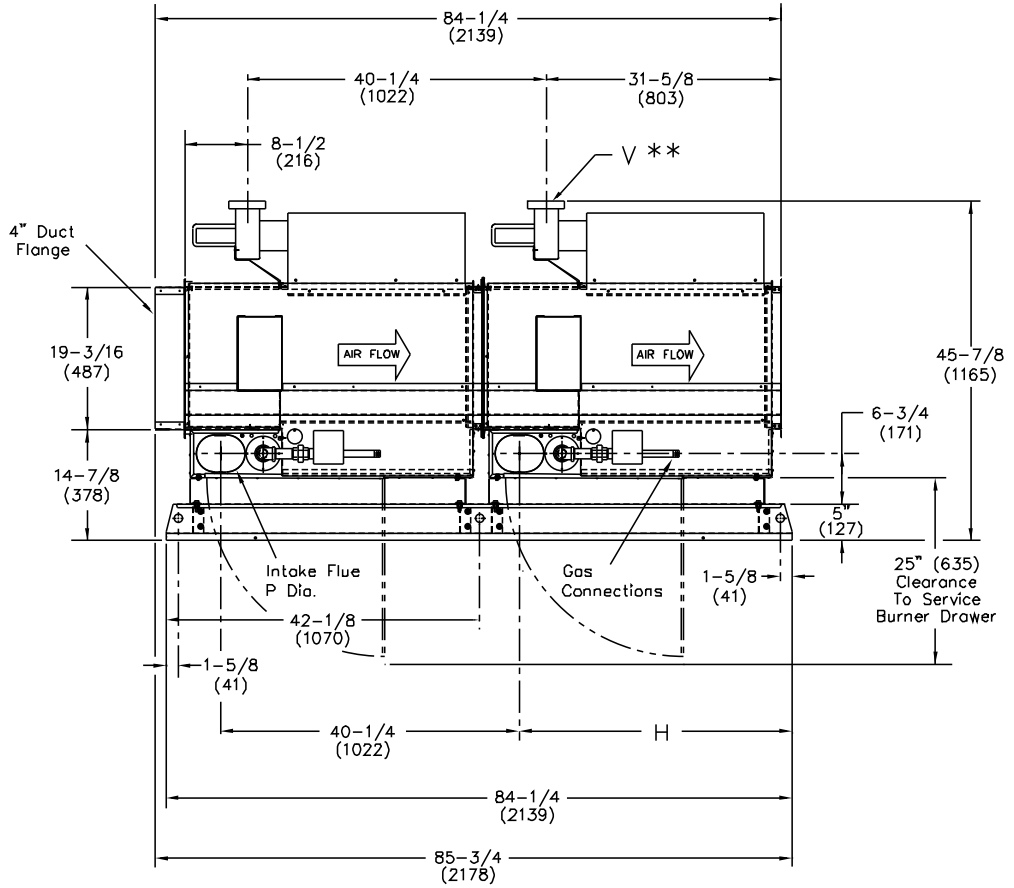
Problem	Probable Cause	Solution
No or Insufficient Cooling	Circulating pump failure.	Repair or replace pump.*
	Chilled water temperature not cool enough.	Check chiller.*
	Air binding (air in coil).	Bleed coil.
	Insufficient chilled water flow.	1. Circulating pump capacity is inadequate.* 2. System piping losses too great.
	Insufficient air flow.	1. See air blower troubleshooting. 2. Clogged coil
	Air bypassing coil.	Caulk safe off.
	Undersized system, demand exceeding cooling system capacity.	Replace system.*
	Too much outside air.	Check outside air dampers.
Water in Conditioned Air	Exceeding coil face velocity - 600 fpm.	Reduce unit air flow.
	Drain pan p-trap clogged.	Clean pan and p-trap.

Note: *Refer to Manufacturer's Installation and Service Manual.

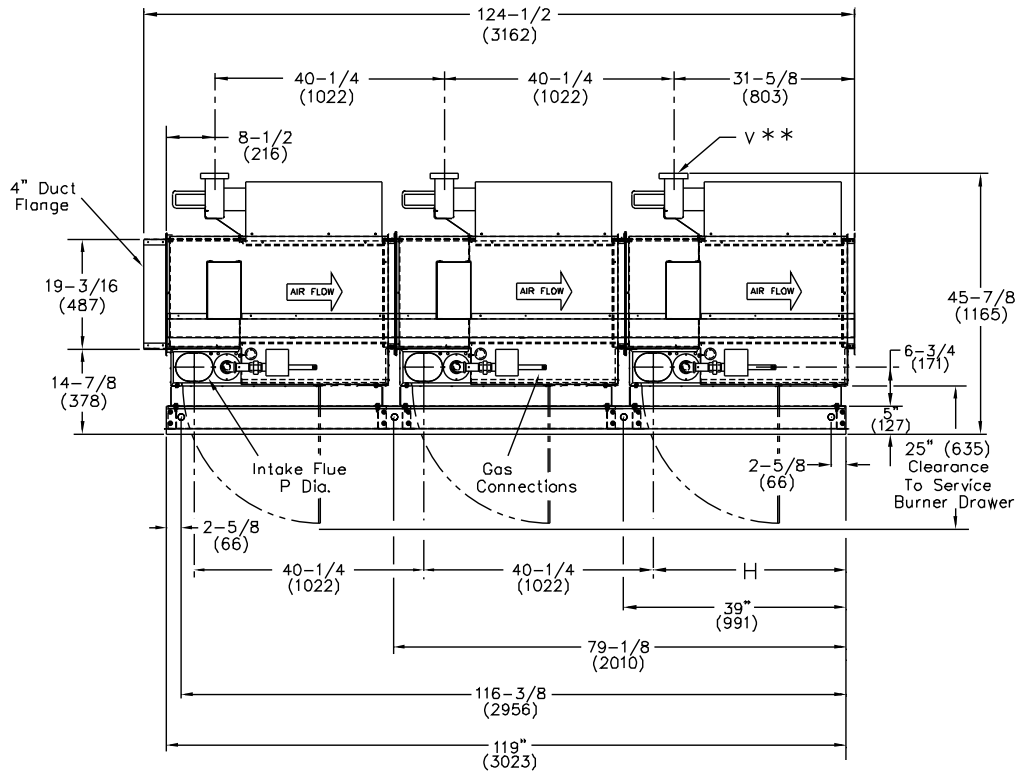


Dimensional Data – Arrangements

Indoor Arrangement A, Capacity 50–80



Indoor Arrangement A, Capacity 12

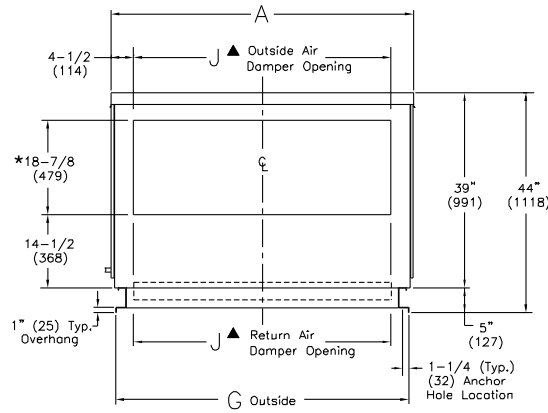


Note: This tabulated dimensional data applies to all dimensional drawings.

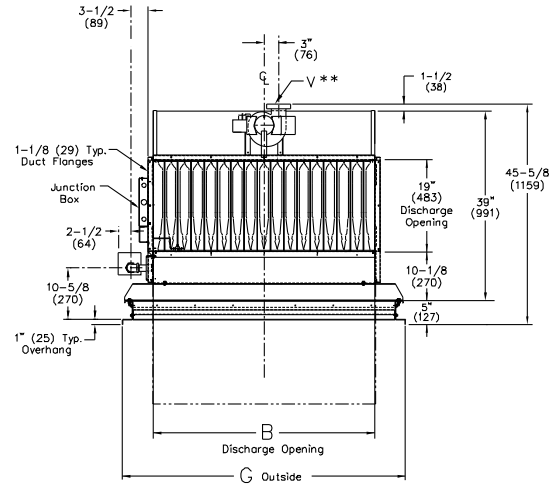
***Capacity											Gas Inlet	
	A	B	C	D	G	H	J▲	P	V Dia. **	NAT	LP	
10	32-7/8 (962)	15-9/16 (395)	16-7/8 (429)	19-3/8 (492)	30-3/16 (767)	37-1/16 (941)	24 (610)	4 RD (102)	4 (102)	1/2	1/2	
15	32-7/8 (962)	18-5/16 (465)	16-7/8 (429)	19-3/8 (492)	30-3/16 (767)	37-1/16 (941)	24 (610)	4 RD (102)	4 (102)	1/2	1/2	
20	43-7/8 (1114)	23-13/16 (605)	21-15/16 (557)	24-7/8 (632)	41-3/16 (1046)	37-7/16 (951)	35 (889)	5 RD (127)	5 (127)	1/2	1/2	
25	43-7/8 (1114)	29-5/16 (745)	21-15/16 (557)	24-7/8 (632)	41-3/16 (1046)	37-7/16 (951)	35 (889)	5 RD (127)	5 (127)	3/4	3/4	
30	54-7/8 (1394)	34-13/16 (884)	27-7/16 (697)	30-3/8 (772)	52-3/16 (1326)	36-11/16 (932)	46 (1168)	6 OV (152)	6 (152)	3/4	3/4	
35	54-7/8 (1394)	40-5/16 (1024)	27-7/16 (697)	30-3/8 (772)	52-3/16 (1326)	36-11/16 (932)	46 (1168)	6 OV (152)	6 (152)	3/4	3/4	
40	60-3/8 (1534)	45-13/16 (1164)	30-3/16 (767)	33-3/16 (843)	57-11/16 (1465)	36-11/16 (932)	51-1/2 (1308)	6 OV (152)	6 (152)	3/4	3/4	
50	43-7/8 (1114)	29-5/16 (745)	21-15/16 (557)	24-7/8 (632)	42-1/16 (1068)	37-7/16 (951)	35 (889)	5 RD (127)	5 (127)	3/4	3/4	
60	54-7/8 (1394)	34-13/16 (884)	27-7/16 (697)	30-3/8 (772)	53-1/16 (1348)	36-11/16 (932)	46 (1168)	6 OV (152)	6 (152)	3/4	3/4	
70	54-7/8 (1394)	40-5/16 (1024)	27-7/16 (697)	30-3/8 (772)	53-1/16 (1348)	36-11/16 (932)	46 (1168)	6 OV (152)	6 (152)	3/4	3/4	
80	60-3/8 (1534)	45-13/16 (1164)	30-3/16 (767)	33-1/8 (841)	58-9/16 (1487)	36-11/16 (932)	51-1/2 (1308)	6 OV (152)	6 (152)	3/4	3/4	
12	60-3/8 (1534)	45-13/16 (1164)	30-3/16 (767)	33-1/8 (841)	58-9/16 (1487)	36-11/16 (932)	51-1/2 (1308)	6 OV (152)	6 (152)	3/4	3/4	

Notes:

- Dimensions are in inches (Dimensions in parenthesis are in millimeters).
- *These dimensions are outside damper measurements.
- RD = Round, OV = Oval
- "J▲" is an outside dimension for return air dampers.
- ** "V" Dia. = Flue Opening; the 4" to 5" reducer adaptor is to field installed for unit capacities 10 & 15. The 5" to 6" increaser adaptor is supplied by the manufacturer for unit capacities 30, 35, 40, 60, 70, 80 & 12 (required for each furnace's flue).
- ***Capacities 10 through 40 are ETL certified.

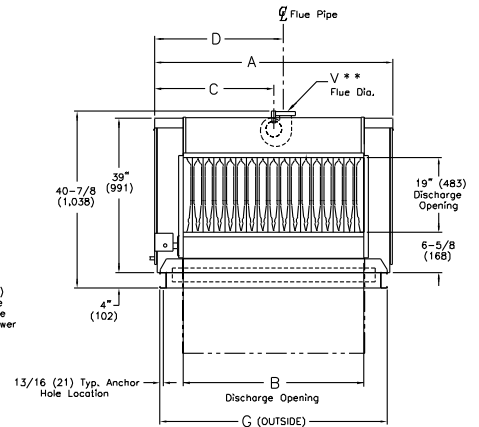
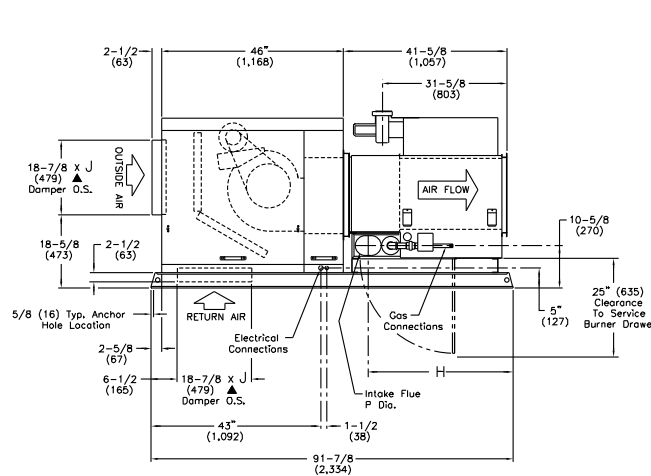


Typical Intake Air End View
(Not applicable to [IA]-A or D
See Evaporative Cooling Specifications)

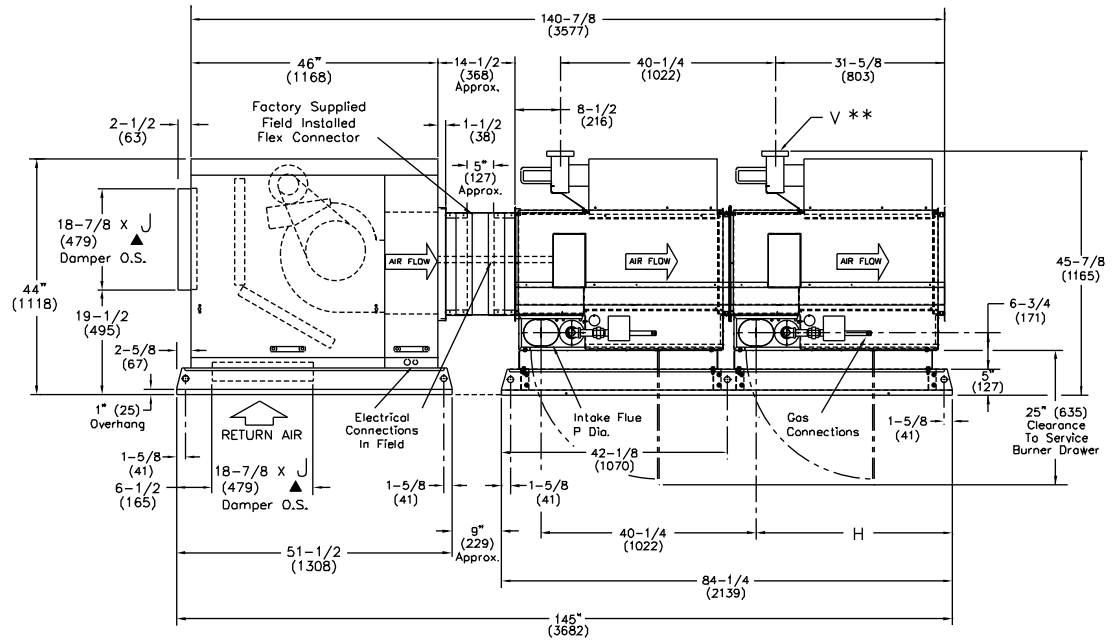


Typical Discharge End View

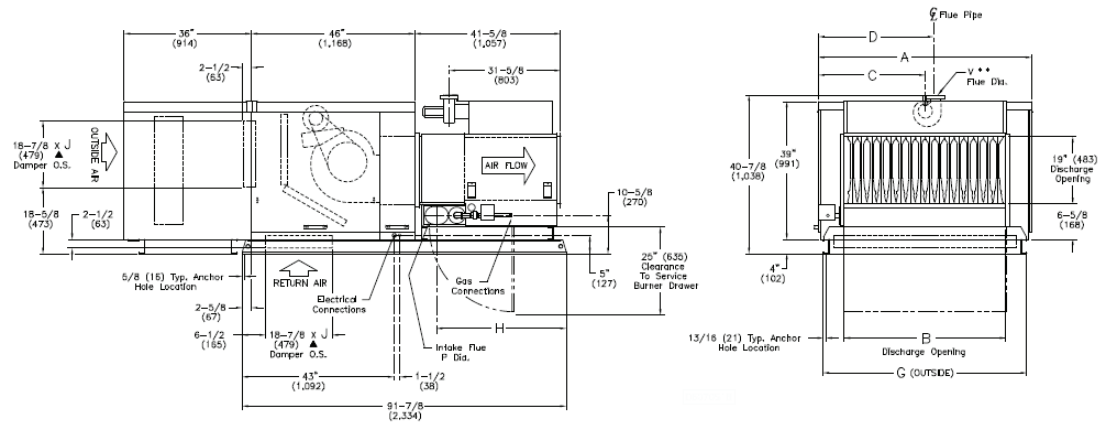
Indoor Arrangement B, Capacity 10–40 (ships in one section)



Indoor Arrangement B, Capacity 50–80 (ships in two sections)



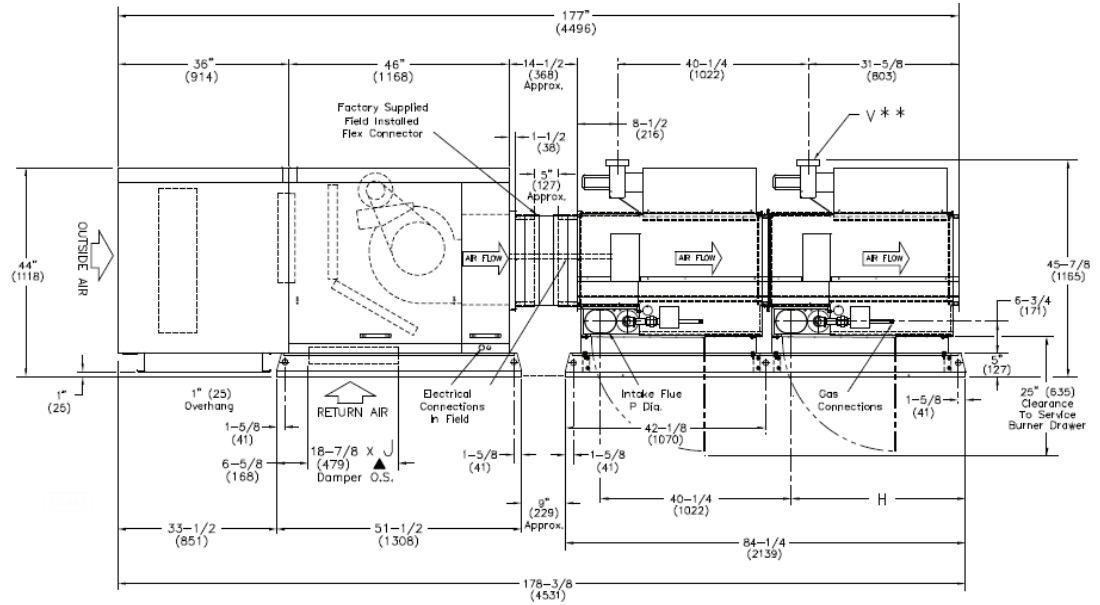
Indoor Arrangements D, Capacities 10–40 (ships in one section)



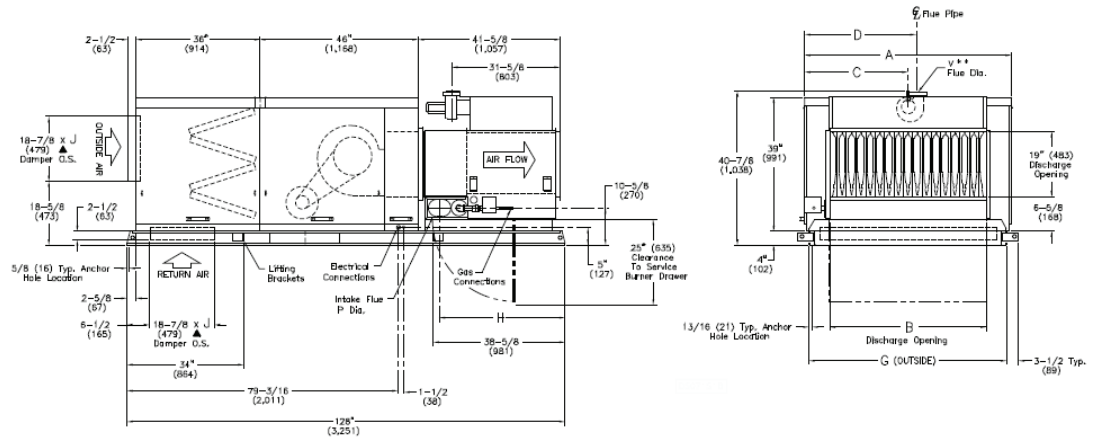


Dimensional Data — Arrangements

Indoor Arrangements D, Capacities 50–80 (ships in two sections)

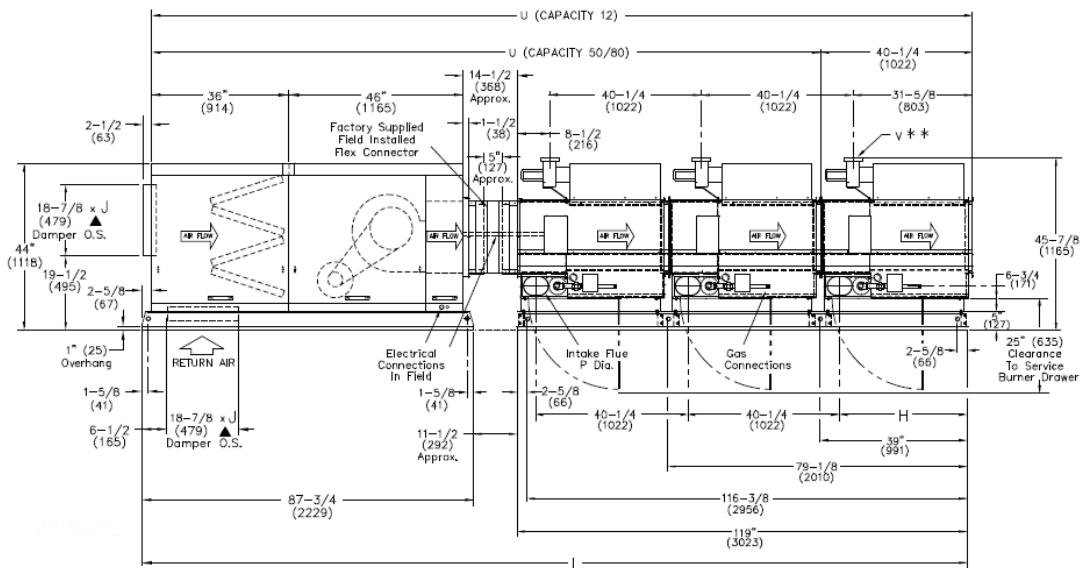


Indoor Arrangements G, Capacities 20–40 (ships in one section)



Indoor Arrangements G, Capacities 50–12 (ships in two sections)

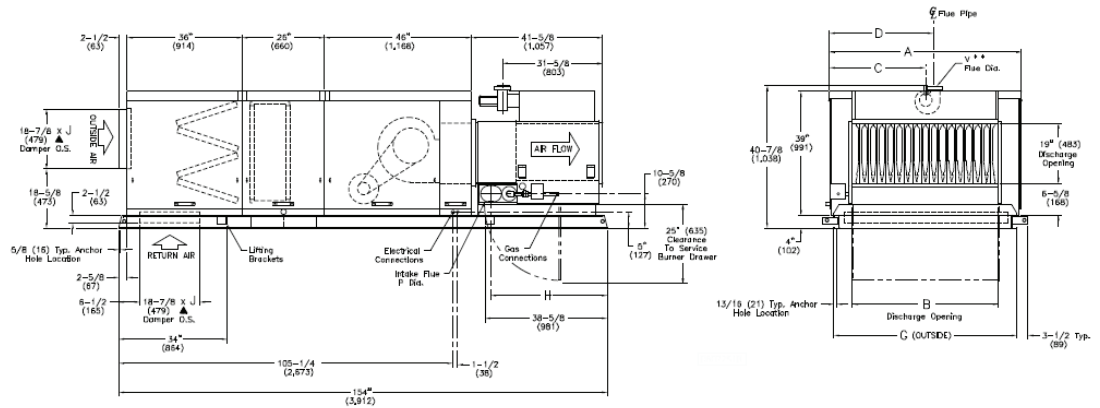
Capacity 12 shown.



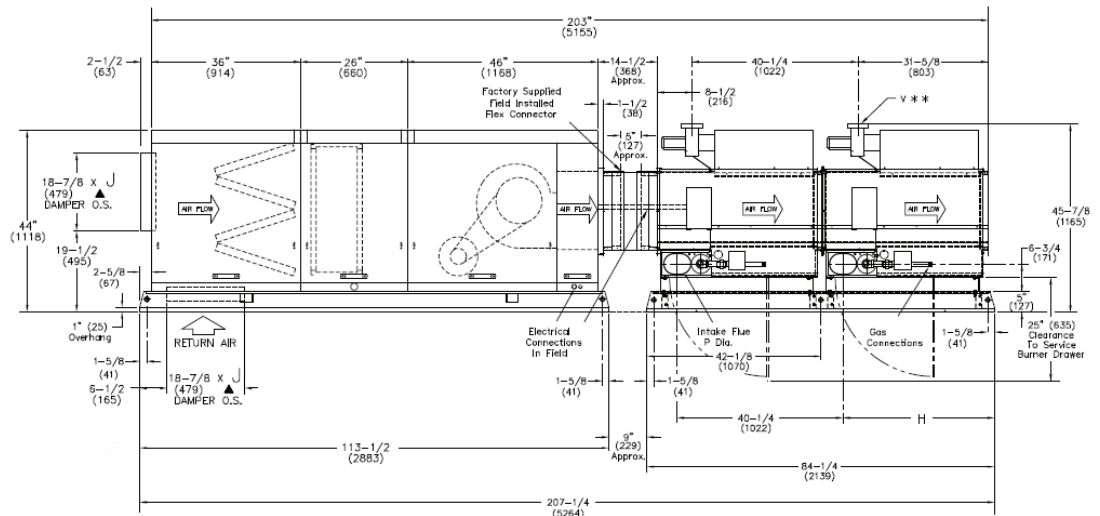


Dimensional Data – Arrangements

Indoor Arrangements K, Capacities 10–40 (ships in one section)



Indoor Arrangements K, Capacities 50–80 (ships in two sections)





Motor Electric Data

Table 4. Full Load Current in Amperes

Full Load Current In Amperes												
	A - (115/1/60)				B - (208/1/60)				C - (230/1/60)			
	1	2	3	4	1	2	3	4	1	2	3	4
	ODP	TE	PEODP	PETE	ODP	TE	PEODP	PETE	ODP	TE	PEODP	PETE
1/2 HP	7.2	8.6	4.6	4.6	3.7		2.8		3.8	4.3	2.3	2.3
3/4 HP	11.6	11.0	6.5	6.3	5.2	5.4	3.4		5.0	5.5	3.3	3.2
1 HP	13.0	13.4	8.6	8.5	6.6	6.8			6.5	6.7	4.3	4.3
1-1/2 HP	18.2	18.0	12.5	12.6	9.1	8.4			9.1	8.0	6.3	6.3
2 HP	21.0	23.0	17.6	17.6	11.3	11.5			10.5	8.1	8.8	8.8
3 HP	33.5	28.0			17.4	14.6			16.8	14.0		11.8
5 HP					23.5				21.0	23.0	19.1	
7-1/2 HP					33.0	31.0			31.0	29.0		
10 HP										38.0		
15 HP												
	D - (208/3/60)				E - (230/3/60)				F - (460/3/60)			
	1	2	3	4	1	2	3	4	1	2	3	4
	ODP	TE	PEODP	PETE	ODP	TE	PEODP	PETE	ODP	TE	PEODP	PETE
1/2 HP	2.3	2.0	1.8	1.7	2.2	2.5	1.8	2.0	1.1	1.0	0.9	1.0
3/4 HP	3.0	3.2	2.5		3.4	3.0	2.4	2.8	1.7	1.5	1.2	1.4
1 HP	3.4	3.7	3.1	3.1	3.4	3.4	3.0	3.1	1.7	1.7	1.5	1.5
1-1/2 HP	5.1	5.0	4.5	4.5	5.2	4.6	4.4	4.4	2.6	2.3	2.2	2.2
2 HP	6.2		5.8	6.0	6.0		5.8	5.8	3.0		2.9	2.9
3 HP	9.2		8.5	9.0	8.6		8.4	8.4	4.3		4.2	4.2
5 HP			12.8	11.8			12.0	11.8			6.0	5.9
7-1/2 HP			20.4	21.0			19.4	18.8			9.7	9.4
10 HP			26.0	27.0			25.0	25.0			12.5	12.5
15 HP			37.4	38.9			35.4	37.0			17.7	18.5
	G - (575/3/60)											
	1	2	3	4								
	ODP	TE	PEODP	PETE								
1/2 HP	0.8	0.8										
3/4 HP	1.1	1.1										
1 HP	1.3	1.7	1.2	1.2								
1-1/2 HP	1.7		1.8	1.8								
2 HP			2.3	2.4								
3 HP			3.4	3.2								
5 HP			5.3	5.3								
7-1/2 HP			7.8	7.6								
10 HP			10.0	9.6								
15 HP			14.1	15.1								

Motor Type (MT) Legend:
 ODP - Open Drip Proof
 TE - Totally Enclosed
 PEODP - Premium Efficiency Open Drip Proof
 PETE - Premium Efficiency Totally Enclosed



Approximate Motor Shipping Weights

Table 5. Approximate Motor Shipping Weights (lbs)

	A - (115/1/60)				B - (208/1/60)				C - (230/1/60)			
	1	2	3	4	1	2	3	4	1	2	3	4
	ODP	TE	PEODP	PETE	ODP	TE	PEODP	PETE	ODP	TE	PEODP	PETE
1/2 HP	20	21	29	30	21		29		21	21	29	30
3/4 HP	23	31	38	41	23	31	38		23	31	38	41
1 HP	32	32	40	44	32	32			32	32	40	44
1-1/2 HP	35	48	47	57		48			35	48	47	57
2 HP	42	67	65	64		67			42	48	65	64
3 HP	78	72			78	72			78	72		90
5 HP					87				87	99	95	
7-1/2 HP					134	138			134	138		
10 HP										161		
15 HP												
	D - (208/3/60)				E - (230/3/60)				F - (460/3/60)			
	1	2	3	4	1	2	3	4	1	2	3	4
	ODP	TE	PEODP	PETE	ODP	TE	PEODP	PETE	ODP	TE	PEODP	PETE
1/2 HP	20	22	22	22	20	22	22	22	20	22	22	22
3/4 HP	27	26	27		27	26	27	31	27	26	27	31
1 HP	24	26	36	37	24	26	36	37	24	26	36	37
1-1/2 HP	31	34	40	42	31	34	40	42	31	34	40	42
2 HP	39		46	49	39		46	49	39		46	49
3 HP	47		69	69	47		69	69	47		69	69
5 HP			76	77			76	77			76	77
7-1/2 HP			117	136			117	136			117	136
10 HP			128	158			128	158			128	158
15 HP			217	255			217	255			217	255
	G - (575/3/60)											
	1	2	3	4								
	ODP	TE	PEODP	PETE								
1/2 HP	22	22										
3/4 HP	20	22										
1 HP	28	27	33	38								
1-1/2 HP			40	42								
2 HP			46	48								
3 HP			66	100								
5 HP			74	91								
7-1/2 HP			114	143								
10 HP			145	153								
15 HP			234	348								

Motor Type Legend:
 ODP - Open Drip Proof
 TE - Totally Enclosed
 PEODP - Premium Efficiency Open Drip Proof
 PETE - Premium Efficiency Totally Enclosed

Approximate Motor Shipping Weights

Table 6. Cooling Coil Weight Adder (Approximate)

Capacity	DX COIL	
	4 Row	6 Row
10, 15	97 lbs.	132 lbs.
20, 25, 50	126 lbs.	177 lbs.
30, 35, 60, 70	165 lbs.	229 lbs.
40, 80	177 lbs.	249 lbs.
Capacity	CHILLED WATER COIL	
	4 Row	6 Row
10, 15	75 lbs.	102 lbs.
20, 25, 50	98 lbs.	135 lbs.
30, 35, 60, 70	125 lbs.	176 lbs.
40, 80	135 lbs.	196 lbs.

Table 7. VFD Enclosure Weight Adder

Small Enclosure, VFD 1–5 HP	95 lbs.
Large Enclosure, VFD 7.5–15 HP	135 lbs.

Table 8. Indoor Arrangement “A, B, D, G, K” Shipping Weights (lbs.)

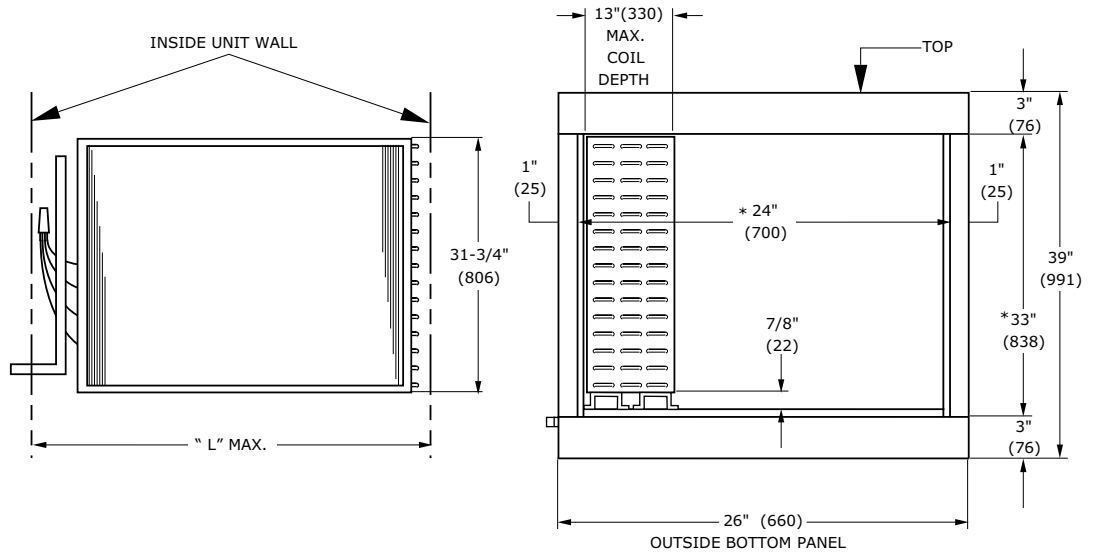
Capacity	Arrangement					Outside Air Hood w/Bird Screen Weight Adder
	A	B	D	G	K	
10		742	904		1137	43
15		739	956		1188	43
20		916	1102	1206	1394	51
25		957	1114	1249	1436	51
30		1092	1301	1452	1659	59
35		1143	1352	1495	1702	59
40		1222	1443	1583	1799	63
50	550	1423	1595	1689	1915	51
60	650	1616	1812	1951	2195	59
70	800	1707	1902	2033	2278	59
80	850	1833	1240	2166	2420	63
12	1300			2741		63

Note: The approximate shipping weights are for a basic unit (these weights do not include the motor, cooling coil, optional outside air hood, flex connector kit, or any options). For units with double wall construction, add an additional 10% of the base unit weight.

Coil Cabinet Dimensional Data

Figure 25. Coil Cabinet Dimensional Data

UNIT SIZE	" L" INSIDE MAX. CABINET OPENING
10/15	31-1/4" (794)
20/25/50	42-1/4" (1073)
30/35/60/70	53-1/4" (1353)
40/80	58-3/4" (1492)



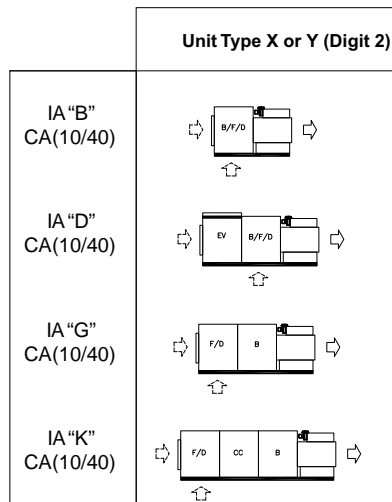
Maximum Coil Dimensions

Side Opening of Coil Module

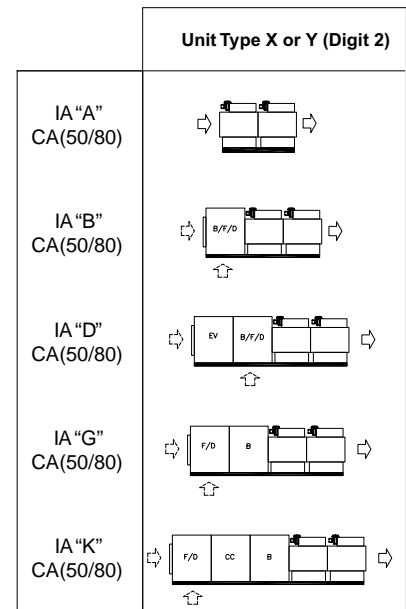


Separated Combustion Indoor Make-Up Air Arrangements

Single Furnace Units (ETL Certified)



Dual Furnace Units



IA = Indoor Arrangement (Digit #14)

CA = Capacity (Digits #5 and 6)

Refer to Complete Model Number Designation in Catalog.

Legend:

B/F/D = Standard Blower/Filter/Damper Module

B = Hi CFM Blower Module

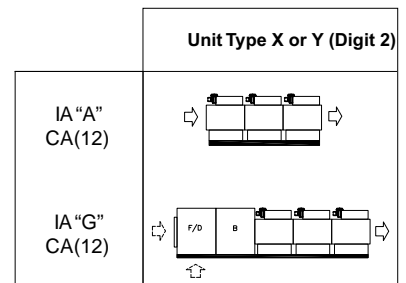
F/D = Hi CFM Filter/Damper Module

CC = Cooling Coil Module

EV = Evap. Cooler Module

Note: Flex connector kits not shown.

Triple Furnace Units





Separated Combustion Indoor Make-Up Unit Number Description

Digit 1 — Gas Heating Equipment

G = Gas Heating Equipment

Digit 2— Unit Type

X = Separate Combustion Indoor Makeup Air Handler

Y = Separated Combustion Duct Furnace Only

Digit 3— Furnace Type (FT)

A = Standard Temp Rise LH (20-60 °F)

B = Standard Temp Rise RH (20-60 °F)

C = High Temp Rise LH (60-90 °F)

D = High Temp Rise RH (60-90 °F)

Digit 4 — Development Sequence

Current Design

Digit 5,6 — Input Capacity

10 = 100 MBH

15 = 150 MBH

20 = 200 MBH

25 = 250 MBH

30 = 300 MBH

35 = 350 MBH

40 = 400 MBH

50 = 500 MBH

60 = 600 MBH

70 = 700 MBH

80 = 800 MBH

12 = 1200 MBH

Digit 7 — Venting Type

P = Power Venting

Digit 8 — Main Power Supply

A = 115/60/1 Main Power Supply

B = 208/60/1 Main Power Supply

C = 230/60/1 Main Power Supply

D = 208/60/3 Main Power Supply

E = 230/60/3 Main Power Supply

F = 460/60/3 Main Power Supply

G = 575/60/3 Main Power Supply

Digit 9 — Gas Control Option

A = Single Stage Gas (Standard)

B = Two Stage Gas

G = Electronic Modulation w/Room Stat

H = Electronic Modulation w/Duct Stat

J = Electronic Modulation w/Duct Sensing & Ovrdr. Stat

K = Electronic Modulation w/External 4-20 MA Input Furnace 1

Digit 9 — Gas Control Option, cont.

L = Electronic Modulation w/External 4-20 MA Input All Furnaces

M = Electronic Modulation w/External 0-10 VDC Input Furnace 1

N = Electronic Modulation w/External 0-10 VDC Input All Furnaces

P = Two Stage Discharge Air Temp Control

R = Three Stage Discharge Air Temp Control

T = Four Stage Discharge Air Temp Control

U = S-350 2 Stage Modular Electronic Control System

W = S-350 3 Stage Modular Electronic Control System

X = S-350 4 Stage Modular Electronic Control System

Y = S-350 6 Stage Modular Electronic Control System

Digit 10, 11 — Design Sequence

Current Design

Digit 12 — Fuel Type

N = Natural Gas

P = LP Gas (Propane)

L = Natural Gas w/100% Lockout

Digit 13 — Heat Exchanger

1 = Aluminized Steel Heat Exchanger

2 = 409 Stainless Steel (First Furnace Only)

3 = 409 Stainless Steel (All Furnaces)

4 = 321 Stainless Steel (First Furnace Only)

5 = 321 Stainless Steel (All Furnaces)

6 = 409 Stainless Steel Package (First Furnace Only)

7 = 409 Stainless Steel Package (All Furnaces)

8 = 321 Stainless Steel Package (First Furnace Only)

9 = 321 Stainless Steel Package (All Furnaces)

Digit 14 — Indoor Arrangement

Includes furnace selection(s)

A = Indoor Duct Furnace (Cap. 50–120 Only)

B = Blower (Standard)

D = Blower (Standard) Evap. Cooling

G = Blower (High CFM)

K = Blower (High CFM) / Coil Cabinet

Digit 15 — Indoor Heating Unit Motor Selection

0 = No Selection (Duct Furnace)

A = 1/2 HP w/Contactor

B = 3/4 HP w/Contactor

C = 1 HP w/Contactor

D = 1-1/2 HP w/Contactor

E = 2 HP w/Contactor

F = 3 HP w/Contactor

G = 5 HP w/Contactor

H = 1/2 HP w/Magnetic Starter

J = 3/4 HP w/Magnetic Starter

K = 1 HP w/Magnetic Starter

L = 1-1/2 HP w/Magnetic Starter

N = 2 HP w/Magnetic Starter

P = 3 HP w/Magnetic Starter

Q = 5 HP w/Magnetic Starter

R = 7-1/2 HP w/Magnetic Starter

T = 10 HP w/Magnetic Starter

U = 15 HP w/Magnetic Starter

V = 1 HP w/VFD

W = 1-1/2 HP w/VFD

X = 2 HP w/VFD

Y = 3 HP w/VFD

Z = 5 HP w/VFD

1 = 7-1/2 HP w/VFD

2 = 10 HP w/VFD

3 = 15 HP w/VFD

Digit 16 — Motor Speed

0 = No Motor Speed (Duct Furnace)

1 = Single Speed ODP 1800 RPM

2 = Single Speed TEFC 1800 RPM

3 = Single Speed High Eff. ODP 1800 RPM

4 = Single Speed High Eff. TEFC 1800 RPM

Digit 17 — Coil Options

0 = No Cooling Coil

A = DX Coil, 4 Row Single Circuit

B = DX Coil, 4 Row Dual Circuit

C = DX Coil, 6 Row Single Circuit

D = DX Coil, 6 Row Dual Circuit

E = Chilled Water Coil, 4 Row

G = Chilled Water Coil, 6 Row

Separated Combustion Indoor Make-Up Unit Number Description

Digit 18 — Air Inlet Configuration

- 0** = No Air Inlet Config. (Duct Furnace)
 - 1** = Single, Horizontal Inlet
 - 2** = Single, Horizontal Inlet w/Air Hood*
 - 3** = Bottom Return Air (RA)
 - 4** = Outside Air/Return Air (OA/RA)
 - 5** = Outside and Return Airw/Air Hood*
- *Hood shipped separately

Digit 19 — Air Control/Damper Arrangement

- 0** = No Air Control/Damper Arr.
- A** = Outside Air 2 Position Motor / Spring Return
- B** = Return Air 2 Position Motor / Spring Return
- C** = OA/RA 2 Position / Spring Return
- Q** = OA/RA Mod. Motor w/CO₂ Monitor Sensor
- E** = OA/RA Mod. Motor w/Mixed Air Control / Min. Pot. / SR
- H** = OA/RA Mod. Motor w/Mixed Air Control / SR
- K** = OA/RA Mod. Motor w/Min. Pot. / SR
- M** = OA/RA Mod. Motor w/Dry Bulb / Mixed Air Control / Min. Pot. /SR
- N** = OA/RA Mod. Motor w/Enthalpy Controlled Economizer / SR
- P** = OA/RA Mod. Motor w/Pressure Control (Space Pressure)
- R** = OA/RA Mod. Motor w/S-350-P Proportional Mixed Air Control / SR
- U** = OA/RA, Motor w/Ext 0-10 VDC/4-20 MA Analog/SR
- W** = ASHRAE Cycle I
- X** = ASHRAE Cycle II
- Y** = ASHRAE Cycle III
- Z** = Manual Dampers

Digit 20 — California Shipment

- 0** = Non California Shipment
- 1** = California Shipment

Digit 21 — Misc. Equipment Options

- A** = High Altitude Orifices
- B** = 12" (305MM) Evaporative Media (Celdek™)
- C** = Moisture Eliminators
- D** = Horizontal Return
- E** = Air Flow Proving Switch
- F** = Freezestat w/Time Delay
- G** = Fan Time Delay
- H** = Return Firestat
- J** = Supply Firestat
- K** = Manual Blower Switch
- M** = Input De-rate
- N** = Double Wall Construction
- P** = Low Leak Damper
- Q** = Clogged Filter Switch
- R** = High/Low Gas Pressure Limit Switch
- T** = Status Indicator Lamp
- V** = Manual Reset High Limit Switch
- W** = 8" (203MM) Evaporative Media (Glasdek™)
- X** = 12" (305MM) Evaporative Media (Glasdek™)
- Y** = Ambient Lockout
- Z** = Freezestat for Evaporative Cooler
- 1** = 1" (25MM) Permanent Filter (std)
- 2** = 2" (51MM) Permanent Filter
- 3** = 2" (51MM) Throwaway Filter
- 4** = 1" (25MM) 30% Pleated Media Filter
- 5** = 2" (51MM) 30% Pleated Media Filter
- 6** = Service Convenience Package

Digit 22 — VFD Installation Options

- 1** = Field Installed VFD
- 2** = Factory Installed VFD
- 3** = VFD Remote Keypad (Field Installed)
- 4** = CO₂ Sensor - 100% Outside Air
- 5** = CO₂ Sensor - Mixed Air
- 6** = Pressure Sensor
- 7** = Two-Speed VFD Relays
- 8** = Three-Speed VFD Relays
- 9** = VFD Enclosure (Only with Factory Installed VFD)



Gas Equipment Start-Up

Customer _____ Job Name & Number _____

PRE-INSPECTION INFORMATION

With power and gas off.

Type of Equip: Unit Heater Duct Furnace Indoor Rooftop

Serial Number _____ Model Number _____

Name Plate Voltage: _____ Name Plate Amperage: _____

Type of Gas: Natural LP Tank Capacity _____ lbs. Rating: _____ BTU @ _____ °F
 _____ kg _____ kw @ _____ °C

- Are all panels, doors, vent caps in place?
- Has the unit suffered any external damage? Damage _____
- Does the gas piping and electric wiring appear to be installed in a professional manner?
- Has the gas and electric been inspected by the local authority having jurisdiction?
- Is the gas supply properly sized for the equipment?
- Were the installation instructions followed when the equipment was installed?
- Have all field installed controls been installed?
- Do you understand all the controls on this equipment? If not, contact your wholesaler or rep.
 (DO NOT START this equipment unless you fully understand the controls.)

GENERAL

With power and gas off.

- Make certain all packing has been removed.
- Tighten all electrical terminals and connections.
- Check damper linkages for tightness.
- Check all fans & blowers for free movement.
- Check all controls for proper settings.
- Check all set screws on blowers and bearings.
- Check belt tightness.

BLOWER

With power on and gas off.

- Check voltage L1 _____ L2 _____ L3 _____
- Check rotation of main blower.
- Check motor amps L1 _____ L2 _____ L3 _____
- Blower RPM _____
- Check air filters (Record quantity & size.)

GAS HEATING

With power and gas on.

- Inlet gas pressure. _____ in. W.C. or _____ kPa
- Pilot & main burner ignition.
- Manifold gas pressure. _____ in. W.C. or _____ kPa
- Cycle on HIGH LIMIT.
- Cycle firestat and/or freezestat.
- Check electronic modulation. Set at: _____
- Cycle and check all other controls not listed.
- Check operation of remote panel.
- Entering air temp. _____ °F or _____ °C
- Discharge air temp. (high fire) _____ °F. or _____ °C
- External static pressure _____ in. W.C. or _____ kPa
- Cycle by thermostat or operating control.
- Combustion Reading.
 Carbon Monoxide _____ PPM
 Carbon Dioxide _____ %

Trane - by Trane Technologies (NYSE: TT), a global innovator - creates comfortable, energy efficient indoor environments for commercial and residential applications. For more information, please visit trane.com or tranetechnologies.com.

Trane has a policy of continuous product and product data improvements and reserves the right to change design and specifications without notice. We are committed to using environmentally conscious print practices.

MUA-SVX006C-EN 13 Aug 2020
Supersedes MUA-SVX006B-EN (May 2017)

©2020 Trane