



Installation, Operation, and Maintenance

Outdoor Rooftop Gas-Fired Duct

Furnace

Power Vented

Model Numbers:

GRAA
GRBA
GRCA

GRDA
AHAA
AHBA

GFCA
GFDA

J30-05815

▲ SAFETY WARNING

Only qualified personnel should install and service the equipment. The installation, starting up, and servicing of heating, ventilating, and air-conditioning equipment can be hazardous and requires specific knowledge and training. Improperly installed, adjusted or altered equipment by an unqualified person could result in death or serious injury. When working on the equipment, observe all precautions in the literature and on the tags, stickers, and labels that are attached to the equipment.

April 2026

MUA-SVX004D-EN

TRANE
TECHNOLOGIES™



Introduction

Read this manual thoroughly before operating or servicing this unit.

Warnings, Cautions, and Notices

Safety advisories appear throughout this manual as required. Your personal safety and the proper operation of this machine depend upon the strict observance of these precautions.

The three types of advisories are defined as follows:



Indicates a potentially hazardous situation which, if not avoided, could result in death or serious injury.



Indicates a potentially hazardous situation which, if not avoided, could result in minor or moderate injury. It could also be used to alert against unsafe practices.



Indicates a situation that could result in equipment or property-damage only accidents.

Important Environmental Concerns

Scientific research has shown that certain man-made chemicals can affect the earth's naturally occurring stratospheric ozone layer when released to the atmosphere. In particular, several of the identified chemicals that may affect the ozone layer are refrigerants that contain Chlorine, Fluorine and Carbon (CFCs) and those containing Hydrogen, Chlorine, Fluorine and Carbon (HCFCs). Not all refrigerants containing these compounds have the same potential impact to the environment. Trane advocates the responsible handling of all refrigerants.

Important Responsible Refrigerant Practices

Trane believes that responsible refrigerant practices are important to the environment, our customers, and the air conditioning industry. All technicians who handle refrigerants must be certified according to local rules. For the USA, the Federal Clean Air Act (Section 608) sets forth the requirements for handling, reclaiming, recovering and recycling of certain refrigerants and the equipment that is used in these service procedures. In addition, some states or municipalities may have additional requirements that must also be adhered to for responsible management of refrigerants. Know the applicable laws and follow them.

⚠ WARNING

Proper Field Wiring and Grounding Required!

Failure to follow code could result in death or serious injury.

All field wiring MUST be performed by qualified personnel. Improperly installed and grounded field wiring poses FIRE and ELECTROCUTION hazards. To avoid these hazards, you MUST follow requirements for field wiring installation and grounding as described in NEC and your local/state/national electrical codes.

⚠ WARNING**Personal Protective Equipment (PPE) Required!**

Failure to wear proper PPE for the job being undertaken could result in death or serious injury.

Technicians, in order to protect themselves from potential electrical, mechanical, and chemical hazards, **MUST** follow precautions in this manual and on the tags, stickers, and labels, as well as the instructions below:

- Before installing/servicing this unit, technicians **MUST** put on all PPE required for the work being undertaken (Examples; cut resistant gloves/sleeves, butyl gloves, safety glasses, hard hat/bump cap, fall protection, electrical PPE and arc flash clothing). **ALWAYS** refer to appropriate Safety Data Sheets (SDS) and OSHA guidelines for proper PPE.
- When working with or around hazardous chemicals, **ALWAYS** refer to the appropriate SDS and OSHA/GHS (Global Harmonized System of Classification and Labelling of Chemicals) guidelines for information on allowable personal exposure levels, proper respiratory protection and handling instructions.
- If there is a risk of energized electrical contact, arc, or flash, technicians **MUST** put on all PPE in accordance with OSHA, NFPA 70E, or other country-specific requirements for arc flash protection, **PRIOR** to servicing the unit. **NEVER PERFORM ANY SWITCHING, DISCONNECTING, OR VOLTAGE TESTING WITHOUT PROPER ELECTRICAL PPE AND ARC FLASH CLOTHING. ENSURE ELECTRICAL METERS AND EQUIPMENT ARE PROPERLY RATED FOR INTENDED VOLTAGE.**

⚠ WARNING**Follow EHS Policies!**

Failure to follow instructions below could result in death or serious injury.

- All Trane personnel must follow the company's Environmental, Health and Safety (EHS) policies when performing work such as hot work, electrical, fall protection, lockout/tagout, refrigerant handling, etc. Where local regulations are more stringent than these policies, those regulations supersede these policies.
- Non-Trane personnel should always follow local regulations.

⚠ WARNING**Cancer and Reproductive Harm!**

This product can expose you to chemicals including lead and bisphenol A (BPA), which are known to the State of California to cause cancer and birth defects or other reproductive harm. For more information go to www.P65Warnings.ca.gov.

Warnings, Cautions, and Notices

⚠ WARNING**Safety Hazard!**

Failure to follow instructions below could result in death or serious injury or property damage.

This unit is not to be used by persons (including children) with reduced physical, sensory, or mental capabilities, or lack of experience and knowledge, unless they have been given supervision or instruction concerning the use of the appliance by a person responsible for their safety.

Do not allow children to play or climb on the unit or to clean or maintain the unit without supervision.

⚠ WARNING**Toxic Fumes and Fibers!**

Install, operate and maintain unit in accordance with manufacturer's instructions to avoid exposure to fuel substances or substances from incomplete combustion which could result in death or serious illness. The State of California has determined that these substances may cause cancer, birth defects, or other reproductive harm. Install and Service this product to avoid exposure to airborne particles of glasswool fibers and/or ceramic fibers known to the State of California to cause cancer through inhalation.



Introduction

Copyright

This document and the information in it are the property of Trane, and may not be used or reproduced in whole or in part without written permission. Trane reserves the right to revise this publication at any time, and to make changes to its content without obligation to notify any person of such revision or change.

Trademarks

All trademarks referenced in this document are the trademarks of their respective owners.

Revision History

- Updated the General Safety Information chapter.
- Updated the Installation chapter.
- Updated the Electrical Connections chapter.
- Updated the Operation chapter.



Table of Contents

- Receiving Instructions 7
 - Pre-Installation Instructions 7
 - Rigging 7
 - Location 7
 - Mounting 7
- General Safety Information 8
- Specifications 10
- Performance Data Curves 13
- Bypass Sizing Information 15
 - Built On the Job (Not Furnished by Factory) 15
 - Use of Bypass Curves 15
- Installation 16
 - Clearances 16
- Venting 18
- Duct Specifications 20
- Gas Connections 21
- Electrical Connections 24
- Operation 25
 - General Information 25
- Controls 28
 - Operating High Limit Control 28
 - Pilot Control 28
 - High Gas Line Pressure Regulator (Natural Gas Only) 28
- Gas Controls 29
 - Single Stage Control 29
 - Two-Stage Control 29
 - Electronic Modulating Control 29
- Air Distribution 31
 - Intermittent Fan Operation 31
 - Constant Fan Operation 31
- Air Throughput 32
 - Air Filters (On Mated Air Moving Device) 32



Table of Contents

Lighting	33
Primary Air Shutter Adjustment	35
Pilot Adjustment	36
Gas Input Adjustment	37
Meter Method of Checking Input	37
Manifold Pressure Method of Checking Input	37
Start-Up	38
Starting Unit In Heating Mode	38
Final Checkout	38
Maintenance	39
Troubleshooting	41
Gas Equipment Start-Up	44



Receiving Instructions

Inspect shipment immediately when received to determine if any damage has occurred to the crate during shipment.

After the unit has been uncrated, check for any visible damage to the unit. Check motor position and turn blower wheel to determine if damage has occurred to these critical parts. If any damage is found, the consignee should sign the bill of lading indicating such damage and immediately file claim for damage with transportation company.

Pre-Installation Instructions

Installer Please Note: This equipment has been test fired and inspected. It has been shipped free from defects from our factory. However, during shipment and installation, problems such as loose wires, leaks or loose fasteners may occur. It is the installer's responsibility to inspect and correct any problems that may be found. When the unit is received and uncrated, check the external data plate and all labels on the unit for type of gas, electrical, and operational specifications to confirm that these agree with those at point of installation.

Note: *It is the owner's responsibility to provide any scaffolding or other apparatus required to perform emergency service or annual/periodic maintenance to this equipment.*

Rigging

Rig the unit using either belt or cable slings. Use spreader bar to protect the top of the unit when it is lifted. The furnace units are provided with two holes in the base rail on each side of the unit. Slide pipes beneath the unit through these holes and attach rigging to the pipes for lifting the unit.

Location

Before placing the rooftop unit in its permanent location, make certain that the roof is capable of carrying the additional load of this equipment. Check the shipping weights given in Chart 2. Refer to Figures 1, 2 and 6 and charts 1 and 2 for adequate unit dimensions and required clearances.

Mounting

The units are mounted on skids and are suitable for use on combustible flooring. It is recommended that the skids be mounted either on level solid planking or steel channels, but never on a soft tar roof where the skids could sink and reduce the clearance between the bottom panel and the roof. Roofcurb kits for rooftop gas heating units are shipped knocked down. A curb kit contains (insulated) curb rails, hardware, sealant, self-adhering rubber gasketing, and installation instructions. Roof insulation, cant strips, flashing, roof felts, caulking and nails must be furnished by the installer. See separate curb specifications from manufacturer.

Maximum allowable installation altitude is 12,000 feet (3,658 meters).



General Safety Information

⚠ WARNING

Hazardous Service Procedures!

Failure to follow all precautions in this manual and on the tags, stickers, and labels could result in death or serious injury.

Technicians, in order to protect themselves from potential electrical, mechanical, and chemical hazards, **MUST** follow precautions in this manual and on the tags, stickers, and labels, as well as the following instructions: **Unless specified otherwise, disconnect all electrical power including remote disconnect and discharge all energy storing devices such as capacitors before servicing. Follow proper lockout/tagout procedures to ensure the power can not be inadvertently energized. When necessary to work with live electrical components, have a qualified licensed electrician or other individual who has been trained in handling live electrical components perform these tasks.**

- The use or storage of gasoline or other flammable vapors or liquids in open containers in the vicinity of this appliance is hazardous.
- If you smell gas:
 - Do not touch electrical switches.
 - Extinguish any open flames.
 - Immediately call your gas supplier.
- Failure to comply with the general safety information may result in extensive property damage, severe personal injury or death!
- This product must be installed by a licensed plumber or gas fitter when installed within the Commonwealth of Massachusetts.
- Do not alter the unit heater in any way or damage to the unit and/or severe personal injury or death may occur!
- Never service any component without first disconnecting all electrical and gas supplies to the unit or severe personal injury or death may occur!
- Ensure that all power sources conform to the requirements of the unit heater or damage to the unit will result!
- Installation must be made in accordance with local codes, or in absence of local codes, with the latest edition of ANSI Standard Z223.1 (NFPA No. 54) National Fuel Gas Code. All of the ANSI and NFPA Standards referred to in these installation instructions are those that were applicable at the time the design of the appliance was certified. The ANSI Standards are available from the American National Standards Institute, Inc., 11 West 42nd Street, New York, NY, 10036 or www.ansi.org. The NFPA Standards are available from the National Fire Protection Association, Batterymarch Park, Quincy, MA 02269.
- If installed in Canada, the installation must conform with local building codes, or in absence of local building codes, with current CSA-B149.1 "Installation Codes for Natural Gas Burning Appliance and Equipment" or CSA-B149.2 "Installation Codes for Propane Gas Burning Appliances and Equipment". These outdoor duct furnaces have been designed for and certified to comply with CSA 2.6.
- These units have been designed and certified for outdoor use only, and may be located on the roof of the building or at any convenient location external of the building to be heated. The input range is 100,000 BTU/HR. (29.3 kW) to 400,000 BTU/HR. (117.1 kW) in 50,000 BTU/HR. (14.6 kW) increments.
- Service Access Panel Removal: To remove an access panel door, use the following procedure: remove the two screws and two washers from the louvered flue discharge area of the service panel (power vent doors only). Each panel is held in place with two "Grip" Latches. Using a slotted head screw driver, turn the latch screwhead counter clockwise. Using the handle provided, pull the panel upwards. Pull the bottom of the panel out and lower the panel to disengage it from the top lip. To replace an access door panel, guide the panel door upwards on the tracks, and push up into the top lip; swing and lower the panel in place until it engages with the bottom panel. Turn the screwhead on each latch clockwise. The screw must turn freely one quarter turn before resistance is felt in order for the lock to engage. If the latch does not hold, turn the screw counter-clockwise several turns and repeat the above procedure. Also refer to , , and for more specifications.
- The venting is an integral part of the unit and must not be altered in the field. Units have a power venting system with the inlet and discharge grille located in the upper section of the side access panel. This balanced flue design also performs well under all wind conditions.

- All internal parts of the standard unit are fabricated from aluminized steel. Standard burners are pressed aluminized steel and have a stainless steel burner port protector and air shutters. All internal and external jacket parts are fabricated from galvanized steel. Stainless steel heat exchangers, burners and flue collectors are optional. An optional 321 or 409 stainless steel heat exchanger is highly recommended for the following applications:
 1. When the entering air temperature is below 40°F (4.4°C),
 2. When the furnace is installed downstream of a cooling coil section.
- A pilot burner plate is provided for access to the pilot burner and ignition systems without removing the burner drawer. Clearances between the external unit and obstruction must be sufficient for proper servicing of pull-out drawer. See , and [Figure 1, p. 10](#) for this clearance.
- The outdoor units are certified for operation on either natural or propane gas. If a unit is to be installed at an altitude exceeding 2000 ft. (610 m) above sea level, derate the input by 4% for each 1000 foot rise(305 m rise) above sea level. Check all local codes.
- Special orifices are required for installations above 2000 ft. (610 m). Check all local codes.
- In Canada, if a unit is to be installed at the altitudes of 2000 ft. (610 m) to 4500 ft. (1372 m), the unit must include an orifice to 90% of the normal altitude rating.
- Unless otherwise specified, the following conversions may be used for calculating SI unit measurements:
 - 1 inch = 25.4 mm
 - 1 foot = 0.305 m
 - 1 gallon = 3.785 L
 - 1 pound = 0.454 kg
 - 1 psig = 6.894 kPa
 - 1 cubic foot = 0.028 m³
 - 1000 Btu/Cu. Ft. = 37.5 MJ/m³
 - 1000 Btu per hour = 0.293 kW
 - 1 inch water column = 0.249 kPa
 - liter/second = CFM x 0.472
 - meter/second = FPM ÷ 196.8
- The appliance is not to be used by persons (including children) with reduced physical, sensory or mental capabilities, or lack of experience and knowledge, unless they have been given supervision or instruction. Children being supervised should not play with the appliance.

Specifications

Table 1. Dimensional data

CAPACITY (CA)	A	B	F ^(a)	K	GAS INLET	
					NAT	LP
10	32-7/8 (835)	15-9/16 (395)	19-3/8 (492)	30-3/16 (767)	1/2	1/2
15	32-7/8 (835)	18-5/16 (465)	23-1/2 (597)	30-3/16 (767)	1/2	1/2
20	43-7/8 (1114)	23-13/16 (605)	26-1/4 (667)	41-3/16 (1046)	1/2	1/2
25	43-7/8 (1114)	29-5/16 (745)	34-1/2 (876)	41-3/16 (1046)	3/4	3/4
30	54-7/8 (1394)	34-13/16 (884)	37-1/4 (946)	52-3/16 (1326)	3/4	3/4
35	54-7/8 (1394)	40-5/16 (1024)	45-1/2 (1156)	52-3/16 (1326)	3/4	3/4
40	60-3/8 (1534)	45-13/16 (1164)	51 (1295)	57-11/16 (1465)	3/4	3/4

Notes:

1. Dimensions are in inches. Dimensions in parenthesis are in millimeters. .
2. Refer to Figure 5 for additional clearance requirements.

^(a) Recommended clearance to service the burner drawer(s).

Figure 1. Standard power vented outdoor duct furnace

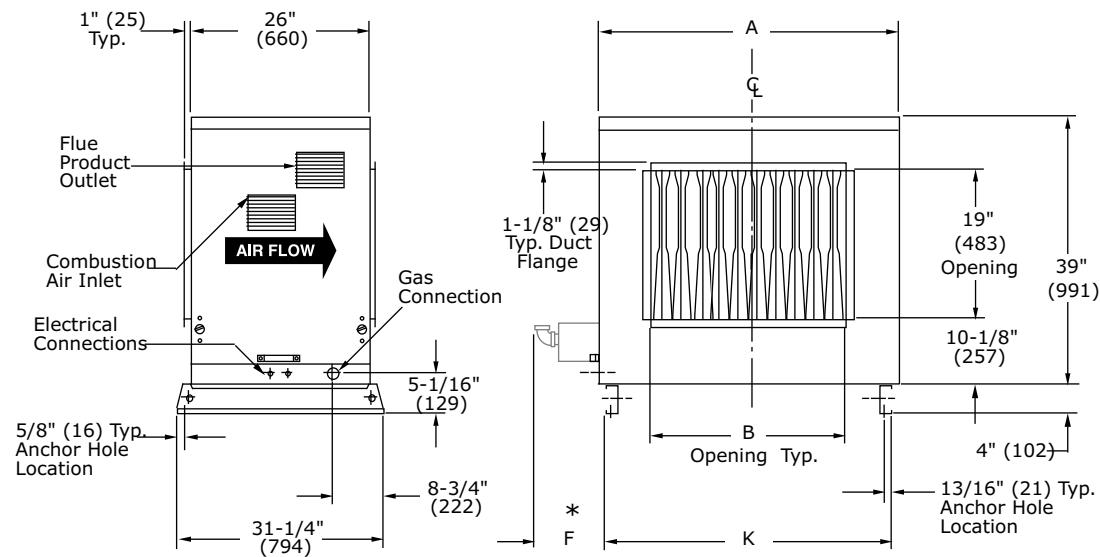

Table 2. Performance and specification data

Capacity	Input Rating BTU/Hr (kW)	Output Rating BBTU/Hr (kW)	Eff %	Min. CFM (cu. m/s)	Max CFM (cu. m/s)	Temp Rise °F (°C)		Static in. of water (Kpa)	F Min. Clearance In. (mm)	NG Gas Inlet in.	LP Gas Inlet in.	Net Weight lb. (kg)	Shipping Weight lb. (kg)
						Min.	Max.						
100 ^(a)	100,000 (29.3)	81,000 (23.7)	81	823 (0.388)	2,469 (1.165)	30 (17)	90 (50)	2 (0.50)	7-1/8 (181)	1/2	1/2	262 (119)	373 (169)
150 ^(a)	150,000 (43.9)	121,500 (35.6)	81	1,235 (0.583)	3,704 (1.748)	30 (17)	90 (50)	2 (0.50)	11-1/4 (286)	1/2	1/2	298 (135)	409 (186)
200 ^(a)	200,000 (58.6)	162,000 (47.5)	81	1,646 (0.777)	4,938 (2.331)	30 (17)	90 (50)	2 (0.50)	14 (356)	1/2	1/2	356 (161)	475 (215)
250 ^(a)	250,000 (73.2)	202,500 (59.3)	81	2,058 (0.971)	6,173 (2.913)	30 (17)	90 (50)	2 (0.50)	22-1/4 (565)	3/4	3/4	395 (179)	514 (233)
350 ^(a)	325,000 (95.2)	263,250 (77.2)	81	2,675 (1.263)	8,025 (3.789)	30 (17)	90 (50)	2 (0.50)	33-1/4 (845)	3/4	3/4	495 (225)	622 (282)
400 ^(a)	400,000 (117.1)	324,000 (95.0)	81	3,292 (1.554)	9,876 (4.661)	30 (17)	90 (50)	2 (0.50)	38-3/4 (984)	3/4	3/4	543 (246)	675 (306)
100 ^(b)	100,000 (29.3)	81,000 (23.7)	81	1,235 (0.583)	3,704 (1.748)	20 (11)	60 (33)	2 (0.50)	7-1/8 (181)	1/2	1/2	259 (117)	370 (168)
150 ^(b)	150,000 (43.9)	121,500 (35.6)	81	1,852 (0.874)	5,556 (2.622)	20 (11)	60 (33)	2 (0.50)	11-1/4 (286)	1/2	1/2	295 (134)	406 (184)
200 ^(b)	200,000 (58.6)	162,000 (47.5)	81	2,469 (1.165)	7,407 (3.496)	20 (11)	60 (33)	2 (0.50)	14 (356)	1/2	1/2	353 (160)	472 (214)
250 ^(b)	250,000 (73.2)	202,500 (59.3)	81	3,086 (1.457)	9,269 (4.375)	20 (11)	60 (33)	2 (0.50)	22-1/4 (565)	3/4	3/4	392 (178)	511 (232)
300 ^(b)	300,000 (87.8)	243,000 (71.2)	81	3,704 (1.748)	11,111 (5.244)	20 (11)	60 (33)	2 (0.50)	34 (864)	3/4	3/4	452 (205)	579 (263)
350 ^(b)	350,000 (102.5)	283,500 (83.1)	81	4,321 (2.040)	12,963 (6.119)	20 (11)	60 (33)	2 (0.50)	33-1/4 (845)	3/4	3/4	492 (223)	619 (281)



Specifications

Table 2. Performance and specification data (continued)

Capacity	Input Rating	Output Rating	Eff %	Min. CFM (cu. m/s)	Max CFM (cu. m/s)	Temp Rise °F (°C)		Static in. of water (Kpa)	F Min. Clearance In. (mm)	NG Gas Inlet in.	LP Gas Inlet in.	Net Weight lb. (kg)	Shipping Weight lb. (kg)
	BTU/Hr (kW)	BBTU/Hr (kW)				Min.	Max.						
MBH	400,000	324,000	81	4,938	14,815	20	60	2	38-3/4	3/4	3/4	540	672
400 ^(b)	(117.1)	(95.0)		(2,331)	(6,993)	(11)	(33)	(0.50)	(984)				(245)

Note: The clearances dimensions shown in Table 2 are the absolute minimum clearances for servicing the burner drawer. However, the clearances shown in Table 1 are the recommended clearances for ease of servicing the unit.

- (a) High temperature rise furnaces.
- (b) Standard temperature rise furnaces.

Performance Data Curves

Figure 2. High temperature rise duct furnace — 30–90°F (17–50°C)

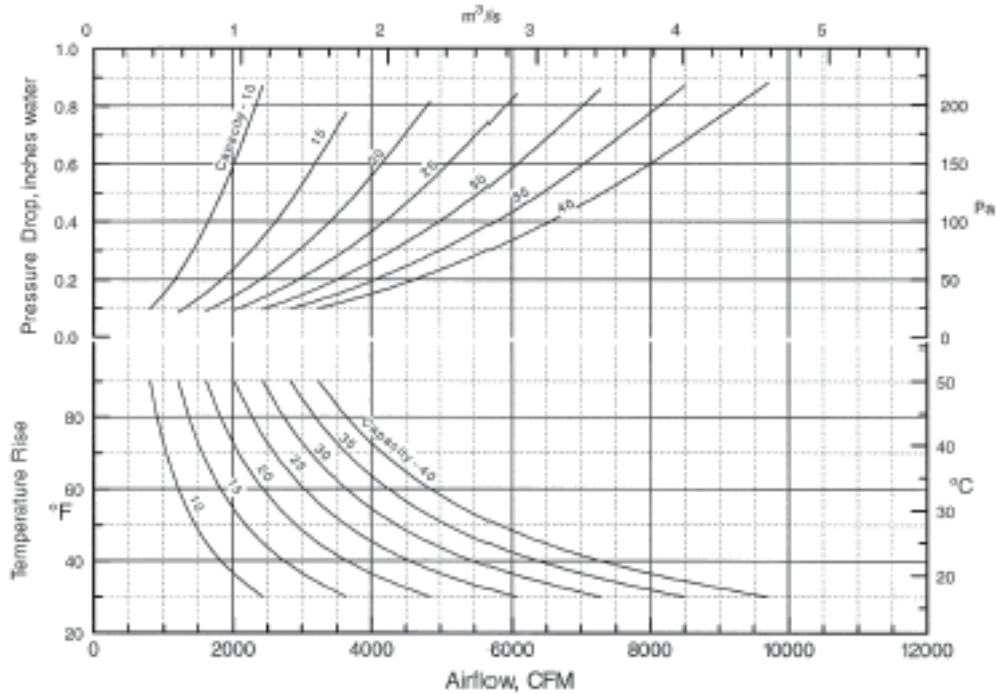

- Pressure drop through the heat exchanger is based on the CFM throughput. The desired data is obtained in the following manner:
 - Select heater size based on heat loss of the building to be heated.
 - Select temperature rise desired.
 - Based on temperature rise, the horizontal line intersects heater temperature vs. CFM curve.
 - Follow vertical line down to select CFM.
 - For pressure drop selection, follow vertical CFM line until it intersects the selected heater performance curve vs. pressure drop.
 - Follow the horizontal pressure drop line to the left, and read pressure drop of the selected heater.

Performance Data Curves

Figure 3. Standard temperature rise duct furnaces — 20–60°F (11–33°C)

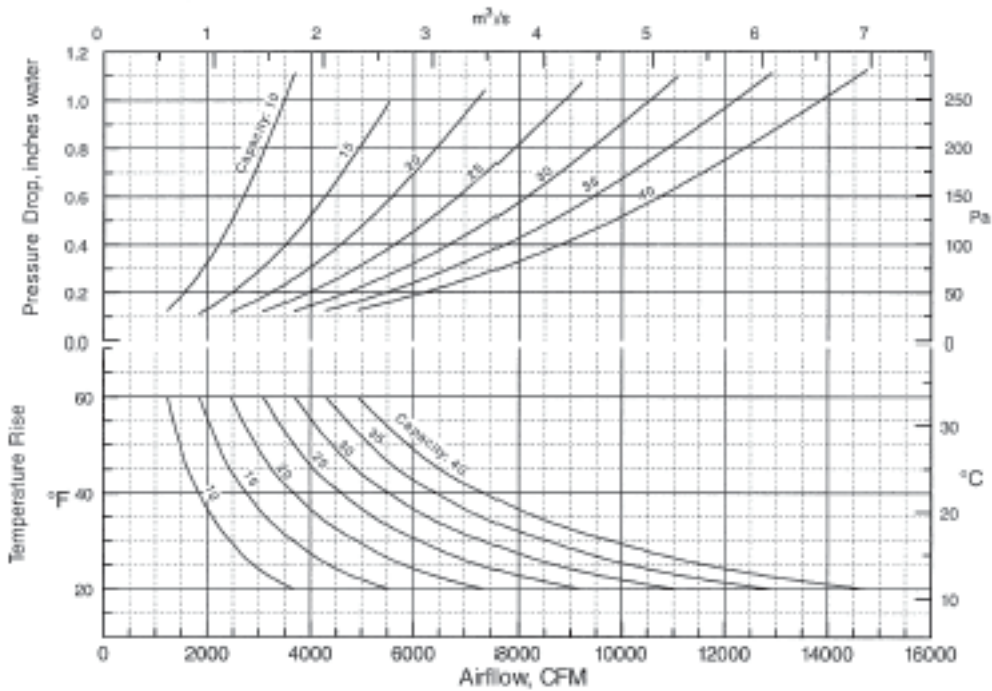

- Pressure drop through the heat exchanger is based on the CFM throughput. The desired data is obtained in the following manner:
 - Select heater size based on heat loss of the building to be heated.
 - Select temperature rise desired.
 - Based on temperature rise, the horizontal line intersects heater temperature vs. CFM curve.
 - Follow vertical line down to select CFM.
 - For pressure drop selection, follow vertical CFM line until it intersects the selected heater performance curve vs. pressure drop.
 - Follow the horizontal pressure drop line to the left, and read pressure drop of the selected heater.



Bypass Sizing Information

Built On the Job (Not Furnished by Factory)

On occasion when a duct furnace is incorporated in an air handling system, it may be desirable to handle a total of more CFM than the duct furnace will pass at a given static pressure drop and temperature rise. Therefore, it is necessary to arrange to bypass the additional CFM required. The size of the bypass duct can be determined by referring to the chart. This permits the static pressure drop through the bypass to balance off the drop through the heat exchanger. The bypass duct is not factory furnished and must be built on the job by the installer and a damper placed therein if required.

Use of Bypass Curves

The width of the by-pass for CFM in excess of that provided through the heater may be found in the following manner:

1. Determine the CFM and pressure drop through the heater based on the heating requirement specifications.
2. Determine the additional CFM desired, over and above the CFM for the heating requirements.
3. Using the pressure drop which was determined from performance curves above, for the heating load, locate this pressure drop on the by-pass curves. Follow this curve until it intersects the vertical CFM line for the excess CFM desired.
4. Follow horizontal line to left to obtain width of bypass duct.

Figure 4. Bypass curve

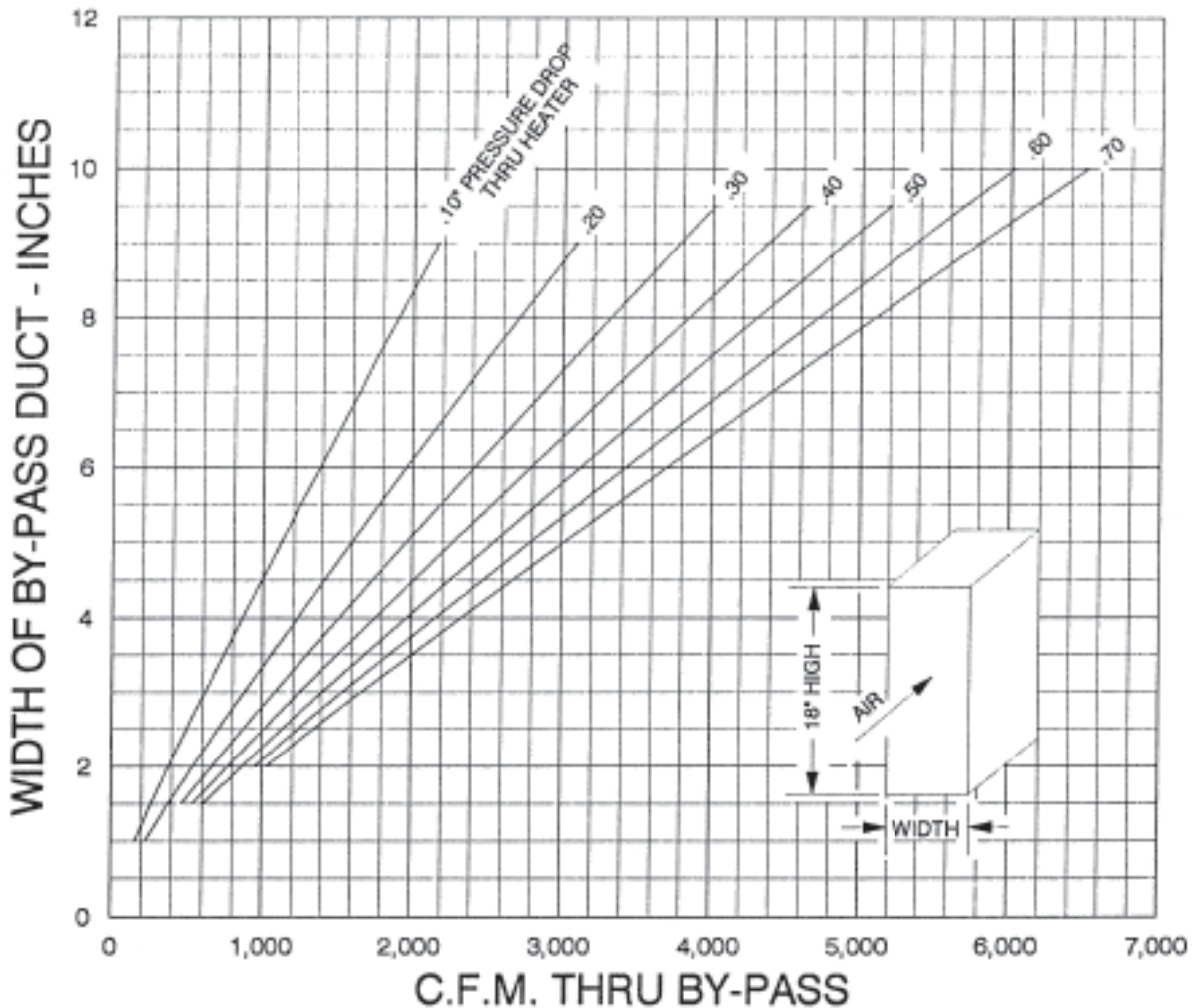



Installation

⚠ WARNING

Hazardous Voltage!

Failure to disconnect power before servicing could result in death or serious injury.

Disconnect all electric power, including remote disconnects before servicing. Follow proper lockout/tagout procedures to ensure the power can not be inadvertently energized. Verify that no power is present with a voltmeter.

Important: Installation must conform with local building codes, or in the absence of local codes, with the latest edition of the National Fuel Gas Code ANSI Z223.1 (NFPA 54).

- A heat loss study and a complete layout of the system should be made first.
- When locating the unit in its permanent location, make certain that the roof is capable of carrying the additional load of the equipment. Check the net weights from the engineering data.
- Make certain that clearances are provided for service and minimum clearance to combustible material. See below for this information. Service clearance information is given in the engineering data in , [Figure 1, p. 10](#), and [Figure 5, p. 17](#). Clearances around secondary air must be unobstructed.
- If the unit is installed downstream of refrigeration coils, condensate will form and collect in the bottom of the heater. Drain connections are provided to dispose of this condensate from the unit. Connect drain pipes to dispose of this condensate where necessary.

Important: Ducts which are outdoors must be insulated and sealed to prevent water from entering either furnace or building through duct (see section on duct and drain specifications).

- Ducts connected to duct furnaces shall have removable access panels on both upstream and downstream sides of the unit. These openings shall be accessible when the unit is installed in service, and shall be of such size that smoke or reflected light may be observed inside the casing to indicate the presence of leaks in the heating element. The covers for the openings shall be attached in such a manner as to prevent leaks.

Important: The duct furnace must be installed on the positive pressure side of the air-circulating blower.

- Atmospheres containing solvents or chlorinated hydrocarbons will produce corrosive acids when coming in contact with the flames. This will greatly reduce the life of the gas duct furnace and may void the warranty. Avoid such areas.
- Maximum altitude for this unit is 14,000 feet (4,267 meters) unless otherwise noted. For altitudes higher than 14,000 feet (4,267 meters), contact your customer service representative.

Clearances

Minimum clearances are shown in , [Figure 1, p. 10](#), and [Figure 5, p. 17](#), as well as from the data in Tables 1 and 2 in the "Specifications," p. 10 section. It is important that clearances be maintained for servicing the unit (refer to and [Figure 1, p. 10](#) for clearances necessary to pull out the burner drawer for servicing), and that minimum clearances are provided from combustible material, flue outlet, and the top of unit. Clearances around the outside air hood must be unobstructed.

⚠ WARNING

Combustible Materials!

Failure to maintain proper clearance between the unit and combustible materials could cause a fire which could result in death, serious injury, or property damage.

Refer to unit nameplate and installation instructions for proper clearances.

Figure 5. Minimum clearances to combustible material or obstructions

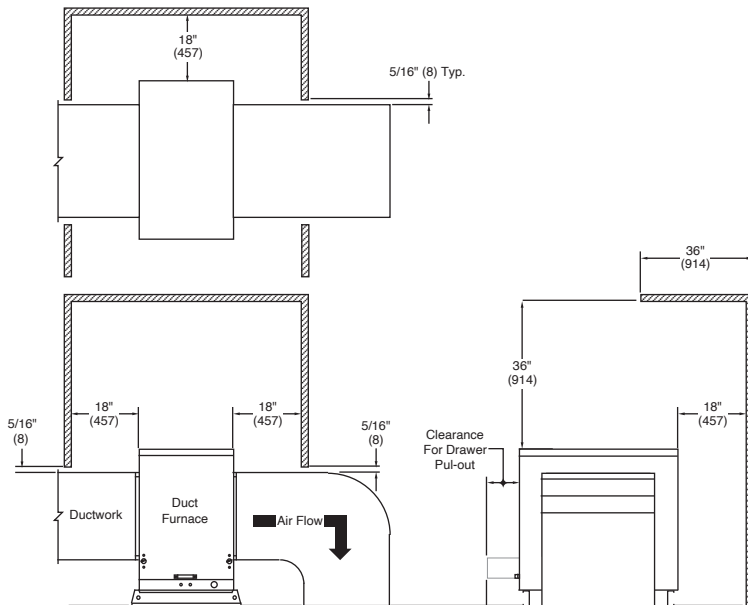

Power vent units require 36 in (914 mm) clearance from the flue product outlet. See [Figure 1, p. 10](#) and Tables 1 and 2 in the “Specifications,” [p. 10](#) section for outlet location.

Venting

Note: All venting installations shall be in accordance with the latest edition of “Part 7, Venting of Equipment of the National Fuel Gas Code, ANSI Z223.1 (NFPA 54), or applicable provisions of local building codes”.

⚠ WARNING

Carbon Monoxide Poisoning!

Failure to follow instructions could result in Carbon Monoxide Poisoning (symptoms include grogginess, lethargy, inappropriate tiredness, or flu-like symptoms) which could result in death or serious injury.

Your venting system must not be blocked by any snow, snow drifts, or any foreign matter. Inspect your venting system to ensure adequate ventilation exists at all times!

Power vented outdoor furnaces are designed with combustion air inlet and flue products outlet located in the louvered side access panel. Keep a minimum clearance of 36" (914 mm) from the flue products outlet, and never locate these units in an area where the flue products outlet may be directed at any fresh air vents. See , , and .

Figure 6. Power venter discharge location

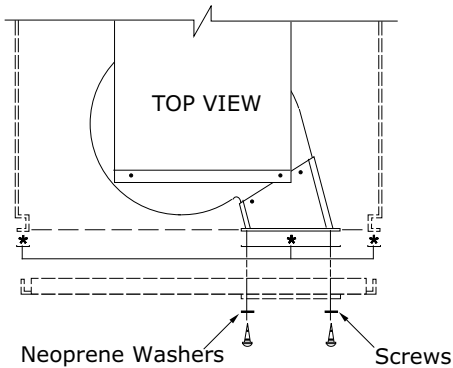

Important:

- These Surfaces (indicated with an asterisk in and) **MUST** be flush and sealed at all times to ensure the proper discharge of flue products from the unit.
- These discharge flanges are equipped with special gasketing, which must create an air tight seal connection around the louvers of the access panel.
- Secure in place the access door to the discharge adaptor using the two screws and neoprene washers, then tighten the grip latches (see service access panel removal section).

Figure 7. Power venter discharge location 2

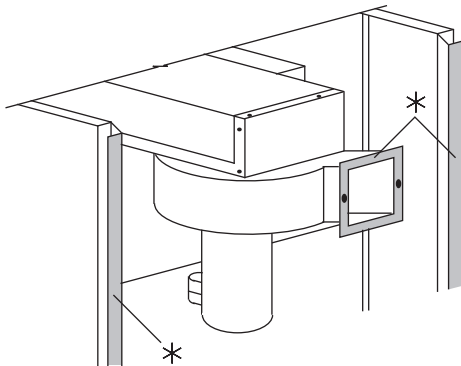
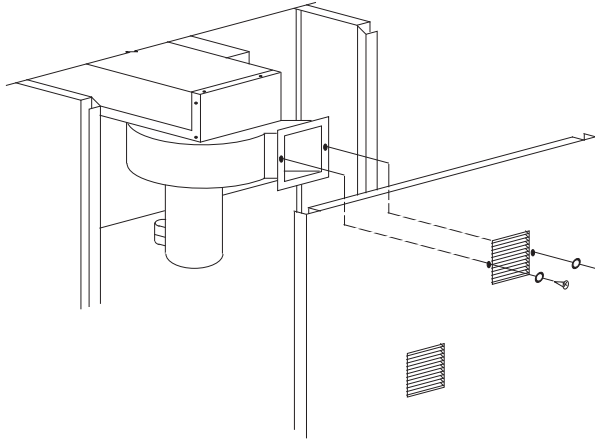

Figure 8. Power venter discharge location 3





Duct Specifications

- Ductwork which is outdoors must be insulated and sealed to prevent water from entering either furnace or building through the duct.
***Important:** Do not alter the flange connection for the duct attachment; air may bypass and cause combustion problems. Be sure to properly seal to avoid any air leakage (see and [Figure 1, p. 10](#)).*
- Ductwork connected to duct furnaces should have removable access panels on both the upstream and downstream sides of the unit. These openings should be accessible when the unit is installed, and should be sized so that smoke or reflected light can be observed inside the casing to indicate the presence of leaks in the heating equipment. The covers of the openings should be attached in a manner that prevents leaks.

Gas Connections

All gas piping should be installed in accordance with local codes. It is required that a ground union be installed adjacent to the manifold for easy servicing. On vertical runs, a drip leg should be provided upstream of the control manifold (See [Figure 9, p. 21](#)). An additional shut-off must be located externally of the jacket enclosure where required by local code. The location of this valve must comply with the local codes. A 1/8 inch NPT plugged tapping, accessible for test gauge connection, must be installed immediately upstream of the gas supply connection to the unit. Field gas piping recommendations are shown in [Figure 10, p. 22](#).

⚠ WARNING

Explosion Hazard!

Failure to follow safe leak test procedures below could result in death or serious injury or equipment or property-only damage.

Never use an open flame to detect gas leaks. Use a leak test solution for leak testing.

It is recommended that the gas piping not be installed through the bottom of the duct furnace bottom panel. If piping must penetrate the duct furnace bottom panel, it must be sealed to prevent water leakage.

⚠ WARNING

Fire Hazard!

Failure to follow instructions below could result in damage to the unit gas valve and cause a fire hazard which could result in death or serious injury.

- **Do NOT connect gas piping to this unit until a supply line pressure/ leak test has been completed.**
- **Do NOT rely on a gas shutoff valve to isolate the unit while conducting gas pressure/leak tests. These valves may not be completely shutoff, exposing the unit gas valve to excessive pressure.**
- **Do not over-tighten the inlet gas piping at unit gas valve.**

- The gas line should be supported so that no strain is placed on the unit. Pipe compounds which are not soluble to liquid petroleum gases should be used on threaded joints.
- The appliance and its individual shutoff valve must be disconnected from the gas supply piping system during any pressure testing of that system at test pressure in excess of 1/2 psig (3.5 kPa).
- The appliance must be isolated from the gas supply piping system by closing its individual manual shutoff valve during any pressure testing of the gas supply piping system at test pressure equal to or less than 1/2 psig (3.5 kPa).

Note: For additional piping information, refer to the latest edition of the National Fuel Gas Code ANSI Z233.1 (NFPA 54).

Figure 9. Drip leg installation

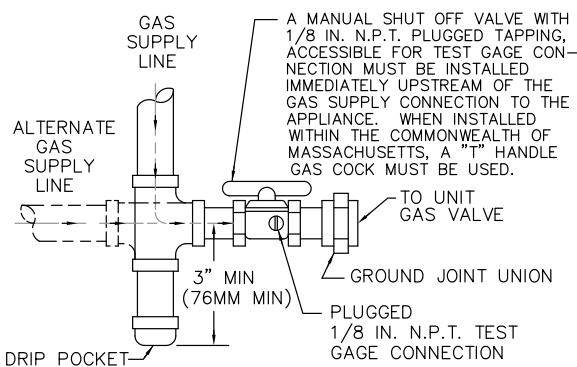
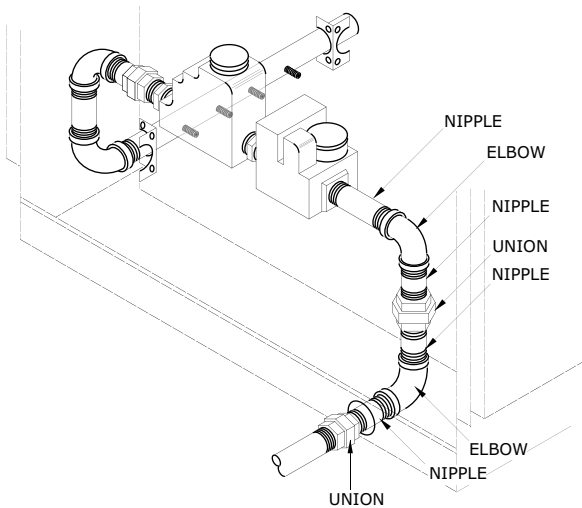

Figure 10. Field piping recommendations

- For the most satisfactory piping installation, the following procedure should be followed. Make piping layout of the whole installation and calculate the cubic feet of gas that each supply pipe will carry. See piping example below.
- Calculate the cubic feet of gas that each supply pipe will carry:

$$\frac{\text{Btu/Hr.}}{1000 \text{ Btu Natural Gas/Cu. Ft.}} = \text{Cu. Ft. Per Hour of Gas to Unit (cfh)}$$

$$\frac{\text{Unit Kilowatt}}{37.3 \text{ Megajoules Natural Gas/Cu Meter}} = \text{Liters per second on Gas to Unit (l/s)}$$

Note: Contact your natural gas supplier for the Btu/Cu. Ft. content of natural gas in your area. This may be higher or lower than the nominal 1000 Btu/Cu. Ft. used in this example:

Referring to the piping example in [Figure 11, p. 23](#), the length of pipe from the gas meter (A) to the most remote heater (E) is 60 feet. This distance should be used for all of the heaters when determining the pipe size required. Based on the column marked 60 feet in chart 3, the piping for this example should be sized as follows:

- 450 cfh is supplied from A to B, requiring 1-1/4 inch pipe.
- 200 cfh is supplied from B to C, requiring 1 inch pipe.
- 250 cfh is supplied from B to D, requiring 1 inch pipe.
- 100 cfh is supplied from D to E, requiring 3/4 inch pipe.
- 150 cfh is supplied from D to F, requiring 1 inch pipe.

Notes:

- For SI calculations, refer to metric conversion chart in general safety section of this manual.
- If more than one gas duct furnace is to be served by the same piping arrangement, the total cu. ft./hr. input and length of pipe must be considered.
- If the gas duct furnace is to be fired with LP gas, consult local LP gas dealer for pipe size information. Heater installation for use with propane (bottled) gas must be made by a qualified LP gas dealer or installer. He will insure proper joint compounds are used for making pipe connections; that air is purged from lines; that a thorough test is made for leaks before operating heater; and that it is properly connected to propane gas supply system.
- Before any connection is made to an existing line supplying other gas appliances, contact the local gas company to make certain that the existing line is of adequate size to handle the combined load.
- Check all connections with a soap solution before leaving job.

Figure 11. Example of piping layout for determining size

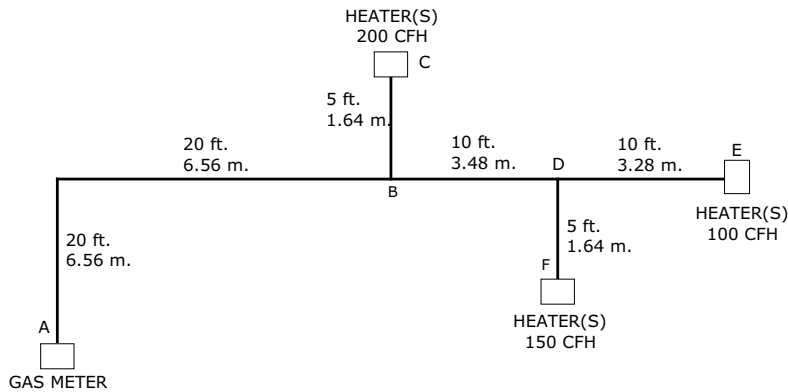

Table 3. Gas pipe size

Maximum Capacity of Pipe in Cubic Feet of Gas per Hour for Gas Pressures of 0.5 psig (3.5 kPa) or Less, and a Pressure Drop of 0.5 Inch Water Column (124.4 Pa) (Based on a 0.60 Specific Gravity Gas)

Nominal Iron Pipe Size in.	Internal Dia. in. (mm)	Length of Pipe, ft. (Meters)													
		10 (3.0)	20 (6.1)	30 (9.1)	40 (12.2)	50 (15.2)	60 (18.3)	70 (21.3)	80 (24.4)	90 (27.4)	100 (30.5)	125 (38.1)	150 (45.7)	175 (53.3)	200 (61.0)
1/2	0.622 (16)	175 (4.96)	120 (3.40)	97 (2.75)	82 (2.32)	73 (2.07)	66 (1.87)	61 (1.73)	57 (1.61)	53 (1.50)	50 (1.42)	44 (1.25)	40 (1.13)	37 (1.05)	35 (0.99)
3/4	0.824 (21)	360 (10.2)	250 (7.08)	200 (5.66)	170 (4.81)	151 (4.28)	138 (3.91)	125 (3.54)	118 (3.34)	110 (3.11)	103 (2.92)	93 (2.63)	84 (2.38)	77 (2.18)	72 (2.04)
1	1.049 (27)	680 (19.3)	465 (13.2)	375 (10.6)	320 (9.06)	285 (8.07)	260 (7.36)	240 (6.80)	220 (6.23)	205 (5.80)	195 (5.52)	175 (4.96)	160 (4.53)	145 (4.11)	135 (3.82)
1 1/4	1.380 (35)	1400 (39.6)	950 (26.9)	770 (21.8)	660 (18.7)	580 (16.4)	530 (15.0)	490 (13.9)	460 (13.0)	430 (12.2)	400 (11.3)	360 (10.2)	325 (9.20)	300 (8.50)	280 (7.93)
1 1/2	1.610 (41)	2100 (59.5)	1460 (41.3)	1180 (33.4)	990 (28.0)	900 (25.5)	810 (22.9)	750 (21.2)	690 (19.5)	650 (18.4)	620 (17.6)	550 (15.6)	500 (14.2)	460 (13.0)	430 (12.2)
2	2.067 (53)	3950 (112)	2750 (77.9)	2200 (62.3)	1900 (53.8)	1680 (47.6)	1520 (43.0)	1400 (39.6)	1300 (36.8)	1220 (34.5)	1150 (32.6)	1020 (28.9)	950 (26.9)	850 (24.1)	800 (22.7)
2 1/2	2.469 (63)	6300 (178)	4350 (123)	3520 (99.7)	3000 (85.0)	2650 (75.0)	2400 (68.0)	2250 (63.7)	2050 (58.0)	1950 (55.2)	1850 (52.4)	1650 (46.7)	1500 (42.5)	1370 (38.8)	1280 (36.2)
3	3.068 (78)	11000 (311)	7700 (218)	6250 (177)	5300 (150)	4750 (135)	4300 (122)	3900 (110)	3700 (105)	3450 (97.7)	3250 (92.0)	2950 (83.5)	2650 (75.0)	2450 (69.4)	2280 (64.6)
4	4.026 (102)	23000 (651)	15800 (447)	12800 (362)	10900 (309)	9700 (275)	8800 (249)	8100 (229)	7500 (212)	7200 (204)	6700 (190)	6000 (170)	5500 (156)	5000 (142)	4600 (130)

Notes:

- *See local codes before installing 1/2" pipe.
- For natural gas:

$$cu. ft/hr = \frac{\text{Input Rate of Unit}}{\text{Btu Value of Gas}}$$

- For propane gas: Multiply the Cu. Ft. / Hr. obtained in the note above by 0.633 before entering chart.



Electrical Connections

⚠ WARNING

Hazardous Voltage!

Failure to disconnect power before servicing could result in death or serious injury.

Disconnect all electric power, including remote disconnects before servicing. Follow proper lockout/tagout procedures to ensure the power can not be inadvertently energized. Verify that no power is present with a voltmeter.

- The rooftop duct furnace is wired at the factory and ready to be connected. Actual wiring will differ according to the options used. Each furnace will be shipped with its own wiring diagram; refer to this wiring diagram for all electrical connections to the unit.

All electrical connections must conform to the latest edition of ANSI/NFPA No. 70 National Electrical Code and applicable local codes; In Canada, to the Canadian Electrical Code, Part I CSA Standard C22.1.

⚠ WARNING

Risk of Electrocutation!

Failure to follow instructions below could result in death or serious injury.

DO NOT use any tools (i.e. screwdriver, pliers, etc.) across the terminals to check for power. You MUST use a CAT III or IV voltmeter rated per NFPA 70E.

- The outdoor conduits leading into the unit should be installed to prevent rain from wetting any high voltage wire. Locate the thermostat in accordance with the instructions packed with each thermostat.
- The short-circuit current rating (SCCR) for this unit is 5kA.

Note: Should any original wire supplied with the heater have to be replaced, it must be replaced with wiring material having a temperature rating of at least 105°C (221°F).



Operation

General Information

- All units are equipped with intermittent pilot ignition systems. The pilot is lit and extinguished during every cycle of operation. There is no burning standing pilot.
- Continuous Retry Models (Gas Type: N - Natural Gas, P - LP/Propane): Continuous retry models provide multiple trials for ignition; the ignitor will continue to spark and pilot gas will continue to flow until the pilot flame is proven. If the pilot is not lit or sensed before the end of the trial for ignition time, the control shuts off the spark and pilot gas (100% shutoff). There is a 5 minute delay before another ignition sequence is initiated. The pattern of ignition sequence followed by a 5 minute delay continues until the pilot lights and is proved or the call for heat ends. The 5 minute delay time can be bypassed by cycling the system thermostat or removing and restoring system power.
- Lockout Models (Gas Type: L - Natural Gas with 100% Lockout): Lockout models provide a single trial for pilot ignition sequence. If the pilot flame is not lit and sensed before the end of the ignition trial time, the control shuts off the pilot valve (100% shutoff) and goes to lockout. The control remains in lockout until power to the control is cycled by the system thermostat or by removing and restoring system power.

Note: Check gas supply pressure (see Table 4 below). Gas valves are suitable to a maximum pressure of 0.5 psi (14 inches water column). If the main gas supply pressure for natural gas is greater than 14 inches WC (3.5 kPa), a step-down pressure regulator must be installed ahead of the gas valve. For LP (propane) gas, the gas pressure supplied should not exceed 14 inches WC (3.5 kPa).

- The controls are located inside the compartment on the access side of the unit. The input for single-stage firing is based on full fire. On two-stage fire, the unit will fire 50% of full fire on the first stage and full fire on the second stage. When electronic modulating is used, the unit will first fire at 100% of full fire and modulate down to 40% of full fire.

Figure 12. Burner components — Intermittent pilot ignition (natural or power vented duct furnaces)

BURNER DRAWER COMMON PARTS:

1. MAIN BURNERS
2. BURNER MANIFOLD
3. AIR SHUTTERS
4. BURNER SPRINGS
5. MAIN BURNER ORIFICE
6. TRANSFORMER
7. PILOT TUBING

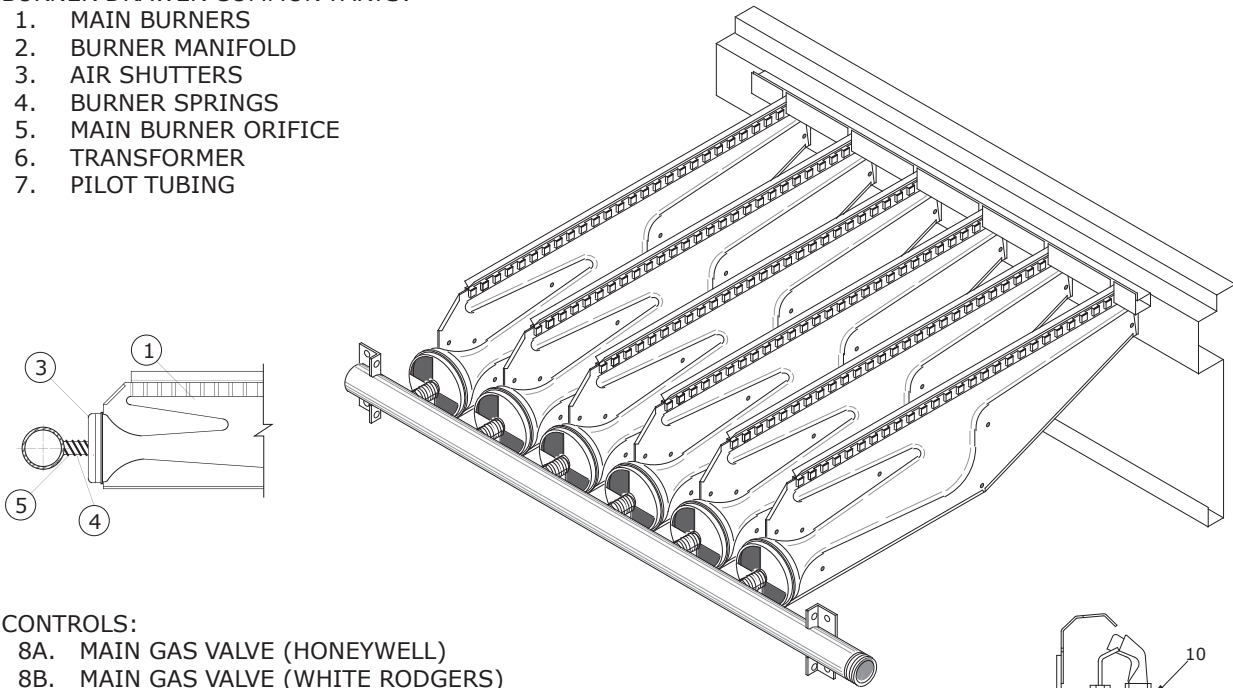

CONTROLS:

- 8A. MAIN GAS VALVE (HONEYWELL)
- 8B. MAIN GAS VALVE (WHITE RODGERS)
9. HONEYWELL IGNITOR
10. PILOT BURNER

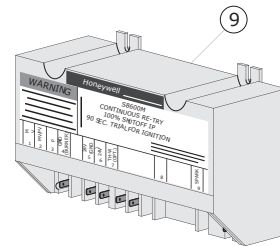
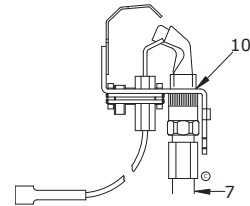
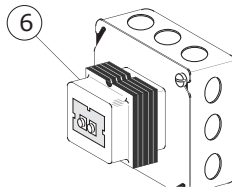
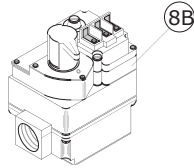
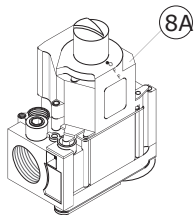

Table 4. Gas supply pressure

Heating Value	Natural Gas	Propane Gas
	1075 Btu/Ft ³ (40.1 MJ/m ³)	2500 Btu/Ft ³ (93.1 MJ/m ³)
Manifold Pressure		
Single Stage Application	3.5 inch WC (0.87 kPa)	10.0 inch WC (2.49 kPa)
Two Stage Application - High Fire	3.5 inch WC (0.87 kPa)	10.0 inch WC (2.49 kPa)
Two Stage Application - Low Fire	1.1 inch WC (0.27 kPa)	3.8 inch WC (0.95 kPa)
Modulating Application - High Fire	3.5 inch WC (0.87 kPa)	10.0 inch WC (2.49 kPa)
Modulating Application - Low Fire	0.9 inch WC (0.22 kPa)	3.5 inch WC (0.87 kPa)
Minimum Supply Pressure		
Single Stage Application	5.0 inch WC (1.24 kPa)	11.0 inch WC (2.74 kPa)

Table 4. Gas supply pressure (continued)

Two Stage Application	6.5 inch WC (1.62 kPa)	11.5 inch WC (2.86 kPa)
Modulating Application	6.5 inch WC (1.62 kPa)	11.5 inch WC (2.86 kPa)
Maximum Supply Pressure	14.0 inch WC (3.49 kPa)	14.0 inch WC (3.49 kPa)



Controls

- Electronic modulating gas firing is available from the factory on natural and propane gas units.
- Do not use a thermostatic fan control switch when either two-stage firing or modulated gas controls are used. A fan time delay switch can be used, however, and is available as an option on outdoor duct furnaces.
- All controls are located on the access side of the unit.
- Table 5 lists orifice sizes for outdoor duct furnaces.

Operating High Limit Control

- The operating limit control is a factory installed component surface mounted in the inlet air stream end of the heat exchanger. This surface mounted safety device must have adequate contact to the rear header plate of the heat exchanger to insure its function.
- When the temperature reaches the limit set point, all heat is shutdown. The limit control has a built in auto-reset that comes on when the equipment is sufficiently cooled down. Reference the unit's wiring diagram.

Pilot Control

Intermittent pilot ignition is standard on all outdoor unit sizes. Intermittent pilot ignition contains a solid state ignition control system that ignites the pilot by spark for each cycle of operation. When the pilot flame is proven, the main burner valve opens to allow gas flow to the burners. Both the pilot and burners are extinguished during the off cycle.

High Gas Line Pressure Regulator (Natural Gas Only)

- The pressure regulator is a field installed component located external of the unit and as close as possible to where the gas line inlet enters the unit.
- The pressure regulator reduces the main gas line pressure to a minimum of seven inches WC (1.74 kPa).



Gas Controls

Single Stage Control

Gas heating units are factory provided with an automatic single-stage gas valve. This valve is an on/off type control, typically activated by a low voltage single-stage thermostat.

1. The thermostat calls for heat.
2. The pilot valve opens.
3. The ignitor sparks continuously to ignite the pilot.
4. The sensor proves pilot ignition and shuts off the ignitor.
5. With the pilot lit, the main gas valve opens.
6. Main burners are lit at 100 percent of unit's rated input.
7. The fan time delay relay (optional) allows the heat exchanger to come up to operating temperature. At this time, the fan time delay relay closes and activates the fan controls.
8. The unit continues to fire until the thermostat is satisfied and no longer calls for heat.
9. The main and pilot valves close.

Two-Stage Control

Optional two-stage control is provided with a two-stage gas valve capable of firing at 100% and 50% of rated input. Ignition at a low fire (50% of the unit's rated input) and the unit is typically controlled by a voltage two-stage thermostat.

With power applied to the unit, this system operates in the following manner:

1. The first stage of the thermostat call for heat.
2. The pilot valve opens.
3. The ignitor sparks continuously to ignite the pilot.
4. The sensor proves pilot ignition and shuts off the ignitor.
5. With the pilot lit, the main gas valve open to low fire.
6. Main burners are lit at 50 percent of unit's rated input.
7. The fan time delay relay (optional) allows the heat exchanger to come up to operating temperature. At this time, the fan time delay closes and activates the fan motor.
8. If additional heat is required, the second stage of the thermostat calls for heat.
9. The main gas valve opens to full fire. The main burners are now at full fire. The unit continues a full fire until the second stage of the thermostat is satisfied and no longer call for heat.
10. The main valve closes to low fire. The main burners are now at low fire. The unit continues at low fire until the first stage of the thermostat is satisfied and no longer calls for heat.
11. The main and pilot valves closes.
12. The fan time delay remains closed, keeping the fan operating to dissipate residual heat from the heat exchanger. At this time, the fan time delay relay opens and deactivates the fan motor.

Electronic Modulating Control

Units with electronic modulating control are provided with an electronic modulating valve capable of firing from 100 percent to 40 percent of rated input. Ignition is at full fire (100 percent of unit's rated input). The electronic modulating valve is controlled by a room thermostat or duct thermostat with remote setpoint adjustment which modulates the gas input from 100 percent to 40 percent of rated input.

An optional override room thermostat is available for use with the duct thermostat. The override room thermostat allows full fire and overrides the duct thermostat when the room temperature falls below the override room thermostat's setpoint.

With power applied to the unit, this system operates in the following manner:

1. The thermostat calls for heat.
2. The pilot valve opens.



Gas Controls

3. The ignitor sparks continuously to ignite the pilot.
4. The sensor proves pilot ignition and shuts off the ignitor.
5. With the pilot lit, the main gas valve opens.
6. Main burners are lit at 100 percent of unit's rated input.
7. The fan time delay relay (optional on duct furnaces) allows the heat exchanger to come up to operating temperature. At this time the fan time delay relay closes and activates the fan motor.
8. The unit is controlled by the electronic thermostat which modulates the unit from 100 to 40 percent of unit's rated input. The electronic thermostat can be a duct sensing device or a room sensing device. An amplifier receives an electrical signal from the thermostat and converts this into a working voltage. This working voltage determines the position of the modulating valve. With no voltage applied to the valve, the valve will be full open and full fire will occur. As increasing voltage is applied to the valve, the valve will modulate closed. At approximately 12 volts DC, the valve will be at its minimum fire position. As temperature drops, the voltage also drops causing the relay to reopen the valve. The unit will continue to cycle in this manner until either an increase in the unit's firing rate is required or the sensing device is satisfied and no longer calls for heat. If the voltage continues to increase, indicating a further reduction in the unit's firing is required, the increased voltage closes a relay which closes the automatic gas valve.
9. When the sensing device is satisfied, the main and pilot valves close.
10. The fan time delay relay remains closed keeping the fan motor operating to dissipate residual heat from the heat exchanger. At this time, the fan time delay relay opens and deactivates the fan motor.



Air Distribution

Two basic air control systems are used to deliver conditioned air to the occupied space: “constant” fan operation and “intermittent” fan operation.

Intermittent Fan Operation

This air control system is available on duct furnaces when the fan time delay relay is ordered (optional). The thermostat turns the gas on whenever the temperature drops below the thermostat setting. The fan time delay relay allows the unit to fire for a period of 60 seconds before fan operation. It also allows the fan to operate for 120 seconds after burner shutdown.

Constant Fan Operation

Duct Furnaces: This air control system is standard on duct furnaces without a fan time delay relay. The blower operates constantly, circulating air through the unit, through the discharge, continuously into the occupied zone, and back to the return. The thermostat turns the gas valve on or off, raising the temperature of the air to maintain comfort conditions in the occupied area.



Air Throughput

Static Pressure through the duct furnace should not exceed 2.0 inches (0.50 kPa) water column. The standard outdoor duct furnaces are operated at a temperature rise range of 20° to 60°F (11° to 33°C) rise. The furnaces are also available at a higher temperature rise range of 30° - 90°F (17° - 50°C).

Important: *It is important that the final temperature leaving the furnace does not exceed 150°F (66°C). When final air throughput adjustments are being made, a quick check of the final temperature can be made by locating a thermometer approximately 6 to 12 inches (152 to 305 mm) downstream from the air discharge and approximately 3 to 4 inches (76 to 102 mm) from the bottom of the duct. The unit should be operated at least 15 to 20 minutes before temperature readings are made.*

⚠ WARNING

Fire Hazard!

Failure to follow instructions below could result in death or serious injury, and property damage.

A unit should never be allowed to cycle on the primary limit for a prolonged period of time. It is a safety control to prevent a fire. If cycling on the primary limit is noted, corrective measures should be taken immediately.

Air Filters (On Mated Air Moving Device)

- It is recommended that air filters be changed or cleaned at least twice a year. More frequent attention will be required if the air being handled is unusually dirty. Air flow reduction, caused by clogging air filters, will increase the discharge air temperature and may cause nuisance trip-outs.
- Filters (by others) should be serviced regularly and changed or washed when necessary to maintain the required throughput. In a dusty environment, filters may clog up in less than one month. A clogged filter switch is recommended to assist with filter maintenance.



Lighting

Important: Purge the gas line of air before attempting to light the pilot in the unit. Wait 5 minutes for unburned gas to vent. Check for gas leaks.

⚠ WARNING

Explosion Hazard!

Failure to follow safe leak test procedures below could result in death or serious injury or equipment or property-only damage.

Never use an open flame to detect gas leaks. Use a leak test solution for leak testing.

The unit is furnished with an intermittent pilot ignition system. A lighting instruction plate is permanently attached to the unit for the pilot system supplied with the unit. To set the intermittent pilot ignition system in operation, proceed as follows:

1. Turn on the main manual valve and pilot valve.
2. Turn on electrical power. The unit should now be under the control of the thermostat.
3. Turn the thermostat to the high heat reading to see if the pilot and main burner ignite.
4. Turn the thermostat to the lowest setting to interrupt power to the ignition system to determine that both the pilot burner and main burner are extinguished.
5. Set the thermostat at the desired setting for normal operation.

For complete shutdown:

1. Turn the main and pilot valves to the OFF position.
2. Shut off electric power.
3. Adjust the thermostat to the lowest setting.

Figure 13. Main burner flames

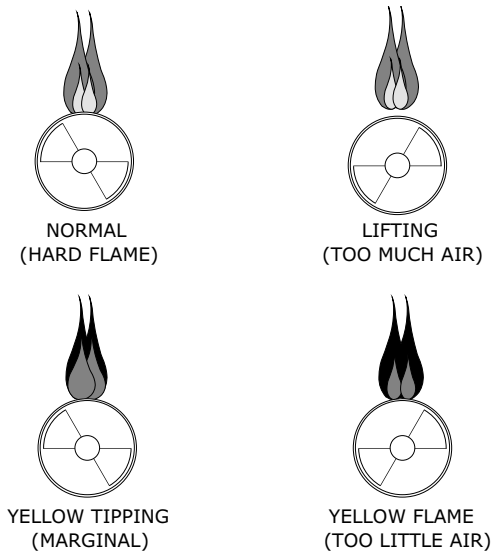

Note: There may be momentary and spasmodic orange flashes in the flame. This is caused by the burning of airborne dust particles, and not to be confused with the yellow tipping, which is a stable or permanent situation when there is insufficient primary air.



Lighting

Table 5. Main burner orifice schedule

Input in 1000 BTU ^(a)	Type of Gas	Std. Temp. Rise furnace (20°-60°F)		Number of burner orifices	High Temp. Rise Furnace (30°-90°F)		
		Natural	Propane		Natural	Propane	
		1075 BTU/Ft ³ (40.1 MJ/m ³)	2500 BTU/Ft ³ (93.1 MJ/m ³)		1075 BTU/Ft ³ (40.1 MJ/m ³)	2500 BTU/Ft ³ (93.1 MJ/m ³)	
Heating Value		3.5 inch WC (0.87kPA)	10 inch WC (2.49 kPA)	3.5 inch WC (0.87kPA)		10 inch WC (2.49 kPA)	
Manifold Pressure							
P ^(b) 100	Ft ³ /HR Orifice Drill	93 42	40 54	4	93 42	40 54	
P ^(b) 125	Ft ³ /HR Orifice Drill	116 42	50 54	5	116 42	50 54	
P ^(b) 150	Ft ³ /HR Orifice Drill	140 42	60 54	6	140 42	60 54	
P ^(b) 175	Ft ³ /HR Orifice Drill	163 42	70 54	7	163 42	70 54	
P ^(b) 200	Ft ³ /HR Orifice Drill	186 42	80 54	8	186 42	80 54	
P ^(b) 225	Ft ³ /HR Orifice Drill	210 42	90 54	9	210 42	90 54	
P ^(b) 250	Ft ³ /HR Orifice Drill	233 42	100 54	10	233 42	100 54	
P ^(b) 300	Ft ³ /HR Orifice Drill	280 42	120 54	12	Not available		
P ^(b) 350	Ft ³ /HR Orifice Drill	326 42	140 54	14	302 43	130 55	
P ^(b) 400	Ft ³ /HR Orifice Drill	372 42	160 54	16	372 42	160 54	

^(a) This schedule is for units operating within the U.S.A. at normal altitudes of 2000 ft. (610m) or less. For altitudes above 2,000 ft., refer to local codes, or in absence of local codes, refer to the latest edition of the National Fuel Gas Code ANSI Standard Z223.1 (NFPA no. 54). When installed in Canada, any references to deration at altitudes in excess of 2000 feet (610m) are to be ignored. At altitudes of 2000 to 4500 feet (610 to 1372m), the unit heaters must be orificed to 90% of the normal altitude rating, and be so marked in accordance with the ETL certification.

^(b) Power vented duct furnaces



Primary Air Shutter Adjustment

- After the unit has been operated for at least 15 minutes, adjust the primary air flow to the burners. Turn the friction-locked, manually-rotated air shutters clockwise to close, or counterclockwise to open.
- For correct air adjustment, close the air shutter until yellow tips in the flame appear. Then open the air shutter to the point just beyond the position where yellow tipping disappears.



Pilot Adjustment

1. With unit firing, remove the pilot adjustment cap.
2. Adjust the pilot screw to provide properly-sized flame.
3. A proper pilot flame is a soft steady flame that envelopes 3/8 to 1/2 inch (9.5 to 12.7 mm) of the flame sensor.
4. Replace the pilot adjustment cap.



Gas Input Adjustment

When shipped from the factory, all gas fired units are equipped for the average BTU of the gas stamped on the rating plate.

NOTICE

Heat Exchanger Damage!
Failure to follow instructions below could result in heat exchanger damage.
Heat content of gas varies by locality; check the gas input after installation of the unit to ensure proper input.
Never exceed the input on the rating plate.

The input may be checked by either the meter method or the pressure of the gas in the manifold. A 1/8 inch pipe tap is available on the body of the gas valve.

NOTICE

Heater Damage!
Do not overfire the unit heater as it could cause unsatisfactory operation or result in heater damage.

Meter Method of Checking Input

1. Obtain the heating value of the gas from the local utility. This should be in BTU per cubic foot (MJ/m³).
2. Determine the cubic feet per minute of the gas as shown in the following example. The rating plate input should be taken from the unit as stamped on the plate. EXAMPLE: Assume this is a unit having an input of 250,000 BTU/hr. and the heating value of the gas to be used in the furnace is 1000 BTU/hr.

$$\begin{aligned} \text{Input} &= \frac{250,000 \text{ BTU/hr.}}{1000 \text{ BTU/cu. ft.} \times 60 \text{ min/hr}} \\ &= 41.7 \text{ cu feet per min.} \end{aligned}$$

Before checking the unit input, all other gas appliances connected to the same meter must be turned off.

3. Fire the unit according to instructions.
4. Observe on the meter dial the cubic feet of gas for a period of five minutes. This should be 41.7 cu ft. per min. x 5 minutes, or 20.8 cu. feet. Minor input adjustments can be made by moving the regulator screw clockwise for increased input and counter-clockwise for decreased input. Any appreciable adjustment in input should be made by re-orificing.

Manifold Pressure Method of Checking Input

1. Close the manual gas valve on the unit.
2. Install a 1/8 inch pipe connection in the tapped hold provided on the valve body and a "U" tube or manometer by means of a rubber hose.
3. Fire the unit and observe the pressure.
4. Small variations in gas pressure adjustment can be made by means of the pressure regulator. Remove the cap from the regulator. Turning the screw clockwise will increase the input, and turning it counterclockwise will decrease the input. The adjusted manifold pressure should not vary more than 10% from the pressures specified in the Main Burner Orifice Schedule chart in the *Lighting* section of this manual.



Start-Up

Before starting the rooftop gas heating unit, use the “Installation Check Sheet” (found at the end of this manual) in conjunction with the procedures outlined below to ensure that the unit is completely and properly installed and ready for start-up.

1. Inspect all wiring connections; connections should be clean and tight.
2. Trace circuits to ensure that actual wiring agrees with the “as wired” diagrams provided with the unit. Information in the title block of the wiring diagram(s) should match the data appearing on the unit nameplate.
3. Verify that the system switch is in the OFF position.
4. Check unit supply voltage to ensure that it is within the utilization range.
5. Inspect the interior of the unit; remove any debris or tools which may be present.

Starting Unit In Heating Mode

⚠ WARNING

Hazardous Voltage!

Failure to disconnect power before servicing could result in death or serious injury.

Disconnect all electric power, including remote disconnects before servicing. Follow proper lockout/tagout procedures to ensure the power can not be inadvertently energized. Verify that no power is present with a voltmeter.

1. Close the unit disconnect switch(s) that provide current to the unit control panel.
2. Set the room thermostat/switching subbase as indicated below:
 - a. Position the heating system switch at either HEAT or AUTO;
 - b. Set the fan switch at AUTO; and,
 - c. Adjust the temperature control setting to some point above room temperature.
3. Place the system switch in the ON position.

Note: *With the thermostat calling for heating, unit operation is automatic.*

Final Checkout

Run the unit sequentially through its stages of heating. Once proper unit operation is verified, perform these final steps:

1. Inspect the unit for debris and/or misplaced tools and hardware.
2. Be sure all gas valves and controls are in the operating position if the unit will be operating immediately
3. Secure all exterior panels in place.



Maintenance

⚠ WARNING

Hazardous Voltage!

Failure to disconnect power before servicing could result in death or serious injury.

Disconnect all electric power, including remote disconnects before servicing. Follow proper lockout/tagout procedures to ensure the power can not be inadvertently energized. Verify that no power is present with a voltmeter.

⚠ WARNING

Check of Safety Devices Required!

Failure to follow instructions below could cause unsafe conditions and result in death, serious injury, or property damage.

All safety controls **MUST** be checked before starting the unit and during regular maintenance! Check and test the operational functions of all safety devices supplied with this unit.

Important: Gas tightness of the safety shut-off valves must be checked on at least an annual basis.

- To check gas tightness of the safety shut-off valves, turn off the manual valve upstream of the appliance combination control. Remove the 1/8 inch pipe plug on the inlet side of the combination control and connect a manometer to that tapping. Turn the manual valve on to apply pressure to the combination control. Note the pressure reading on the manometer, then turn the valve off. A loss of pressure indicates a leak. If a leak is detected, use a soap solution to check all threaded connections. If no leak is found, combination control is faulty and must be replaced before putting appliance back in service.
- Rooftop duct furnaces have been developed for outdoor installation. Should maintenance be required, perform the following inspection and service routine: Inspect area near the unit to be sure that there is no combustible material located within minimum clearance requirements (refer to , [Figure 1](#), p. 10, and [Figure 5](#), p. 17. Service panels provide easy access to the burner controls. To remove the service door, refer to "Access Panel Removal" section (In the General Safety Information chapter).
- The pilot burner can be serviced by removing the pilot plate from the main burner assembly.

To remove the main burner drawer assembly for servicing the burners, proceed as follows:

1. Shut off the main gas valve and electrical power to the gas duct furnace.
2. To slide out the burner drawer, the following two procedures (a or b) may be chosen depending on the complexity of the unit's controls:
 - a. Disconnect the pilot burner gas tube. Break the union between the automatic gas valve and the burner manifold. Also break the union on the discharge air end of the furnace (inside the unit). Loosen the union located directly outside of the furnace's bottom panel (refer to [Figure 10](#), p. 22 in the *Gas Connections* chapter). Swing down this end of the piping to clear the bottom of the burner drawer. The control and piping assembly may be tied out of the way of the pull-out drawer.
 - b. Disconnect all wiring to the unit's controls. Break the union located in the discharge end of the furnace; loosen the external union, and swing piping clear of the bottom of the drawer (same procedure as 'a').
3. Remove the locking screws holding the burner drawer in position.
4. Slide the drawer out of the furnace.
5. Burners can be removed from the drawer by raising the front of the burner and pushing it against the hold-in spring until the front of the burner comes out of the slot.
6. To clean or replace the main burners, slide out the pullout drawer, and compress the spring by moving the burner toward the manifold. Slide the opposite end of the burner downward from the locating slot while retaining spring is still compressed. Pull the burners upward and out.
7. Remove any dirt, dust or other foreign matter from the burners using a wire brush and/or compressed air. Ensure that all parts are unobstructed. Inspect and clean pilot burner if necessary.
8. Reassemble the gas duct furnace by replacing all parts in order.
9. Complete the appropriate unit start-up procedure as given in the "Start-Up" section of this manual.
10. Check the burner adjustment. See the "Primary Air Shutter Adjustment" chapter of this manual.
11. Check all gas control valves and pipe connections for leaks.

⚠ WARNING**Combustible Materials!**

Failure to maintain proper clearance between the unit and combustible materials could cause a fire which could result in death, serious injury, or property damage.

Refer to unit nameplate and installation instructions for proper clearances.

12. Check the operation of the automatic gas valve by lowering the setting of the thermostat, stopping the operation of the gas duct furnace. The gas valve should close tightly, completely extinguishing the flame on the main burners.
13. Check the operation of all safety devices.
14. Inspect and service the blower section of the system.
 - The outdoor unit should be thoroughly checked before the start of the heating season. Check the air through-put as an added precaution to stay within the specified temperature limits.
 - If the unit is used with cooling equipment, periodic maintenance should be scheduled throughout the year.

Figure 14. Power Vent Duct Furnace





Troubleshooting

Symptoms	Possible Causes	Corrective Actions
Gas odor	<ol style="list-style-type: none"> 1. Shut off gas supply immediately. 2. Blocked heat exchanger. 3. Drafts around heater. 4. Negative pressure in the building. 5. Blocked draft hood/flue connector. 	<ol style="list-style-type: none"> 1. Inspect all gas piping and repair. 2. Clean heat exchanger. 3. Eliminate Drafts. Refer to installation. 4. See installation. 5. Clean draft hood/flue collector.
Delayed Ignition	<ol style="list-style-type: none"> 1. Excessive primary air. 2. Main burner ports clogged near pilot. 3. Pressure regulator set too low. 4. Pilot decreases in size when main burners come on. 5. Pilot flame too small. 	<ol style="list-style-type: none"> 1. Close air shutter. Refer to operation. 2. Clean main burner ports. 3. Reset manifold pressure. Refer to operation. 4. Supply piping is inadequately sized. Refer to installation. 5. Clean pilot orifice. Refer to operation.
Pilot will not light, or will not stay lit	<ol style="list-style-type: none"> 1. Main gas off. 2. Pilot adjustment screw turned too low on combination main gas valve. 3. Air in gas line. 4. Dirt in pilot orifice. 5. Extremely high or low gas pressure. 6. Pilot valve not opening. <ol style="list-style-type: none"> a. Faulty wiring. b. Defective ignition control. c. Defective valve. 7. No spark. <ol style="list-style-type: none"> a. Faulty wiring. b. Defective pilot. c. Defective ignition control. d. Sensor grounded. 	<ol style="list-style-type: none"> 1. Open all manual gas valves. 2. Increase size of pilot flame. 3. Purge air from gas supply. 4. Remove pilot orifice. Clean with compressed air or solvent. (Do not ream). 5. Refer to operation. 6. <ol style="list-style-type: none"> a. Inspect & correct all wiring. b. Replace. 7. Replace. <ol style="list-style-type: none"> a. Inspect & correct all wiring. b. Replace c. Replace. d. Inspect & correct ignition system.
Main burners will not light	<ol style="list-style-type: none"> 1. Main gas off. 2. Lack of power at unit. 3. Thermostat not calling for heat. 4. Defective limit switch. 5. Improper thermostat or transformer wiring at gas valve. 6. Defective gas valve. 7. Defective thermostat. 8. Defective transformer. 9. Loose wiring. 10. Defective ignition control. 	<ol style="list-style-type: none"> 1. Open all manual gas valves. 2. Replace fuse or turn on power Replace fuse or turn on power 3. Turn up thermostat. 4. Check limit switch with continuity tester. If open, replace limit switch. 5. Check wiring per diagrams. 6. Replace gas valve. 7. Check thermostat and replace if defective. 8. Be sure 115 volts is supplied to the transformer primary then check for 24 volts at secondary terminal before replacing. 9. Check and tighten all wiring connections. 10. Replace.
Flame lifting from burner ports	<ol style="list-style-type: none"> 1. Pressure regulator set too high. 2. Defective regulator. 3. Burner orifice too large. 	<ol style="list-style-type: none"> 1. Reset manifold pressure. Refer to operation. 2. Replace regulator section of combination gas valve or complete valve. 3. Check with local gas supplier for proper orifice size and replace. Refer to operation.



Troubleshooting

Symptoms	Possible Causes	Corrective Actions
Flame pops back	Excessive primary air.	<ol style="list-style-type: none"> 1. Close air shutter. Refer to Operation. 2. Check with local gas supplier for proper orifice size and replace.
Noisy flame	<ol style="list-style-type: none"> 1. Too much primary air. 2. Noisy pilot. 3. Irregular orifice causing whistle or resonance. 4. Excessive gas input. <ol style="list-style-type: none"> a. Pressure regulator set too high. b. Defective regulator. c. Burner orifice too large. 	<ol style="list-style-type: none"> 1. Close air shutter. Open all manual gas valves. 2. Reduce pilot gas. Refer to operation. 3. Replace orifice. 4. <ol style="list-style-type: none"> a. Reset manifold pressure Refer to operation. b. Replace regulator section of combination gas valve or complete valve. c. Check with local gas supplier for proper orifice size and replace. Refer to operation.
Yellow tip flame (some yellow tipping on propane gas is permissible)	<ol style="list-style-type: none"> 1. Insufficient primary air. 2. Clogged main burner ports. 3. Misaligned orifices. 4. Air shutter linted. 5. Insufficient combustion air. 6. Clogged draft hood/flue collector. 	<ol style="list-style-type: none"> 1. Open air shutters. Refer to operation. 2. Clean main burner ports. 3. Replace manifold assembly. 4. Check for dust or lint at air mixer opening and around the air shutter. 5. Clean combustion air inlet openings in bottom panel. Refer to installation. 6. Clean draft hood/flue collector.
Floating flame	<ol style="list-style-type: none"> 1. Blocked heat exchanger. 2. Insufficient combustion air. 3. Blocked venting. 4. Air leak into combined chamber, draft hood, or flue collector. 	<ol style="list-style-type: none"> 1. Clean heat exchanger. 2. Clean combustion air inlet openings in bottom panel. Refer to installation. 3. Clean flue. Refer to installation 4. Determine cause and repair accordingly. Refer to installation.
Burner won't turn off	<ol style="list-style-type: none"> 1. Poor thermostat location. 2. Defective thermostat. 3. Improper thermostat or transformer. 4. Short circuit. 5. Defective or sticking gas valve. 6. Excessive gas supply pressure. 	<ol style="list-style-type: none"> 1. Relocate thermostat away from drafts. 2. Replace thermostat. 3. Check wiring diagrams. 4. Check operation at valve. Look for short and correct (such as staples piercing thermostat wiring). 5. Replace gas valve. 6. Refer to operation.
Rapid burner cycling	<ol style="list-style-type: none"> 1. Loose electrical connections at gas valve or thermostat. 2. Excessive thermostat heat anticipation. 3. Unit cycling on high limit. 4. Poor thermostat location. 	<ol style="list-style-type: none"> 1. Tighten all electrical connections. 2. Adjust thermostat heat anticipation for longer cycles. Refer to operation. 3. Check for proper air supply across heat exchanger. 4. Relocate thermostat. (Do not mount thermostat on unit).

Symptoms	Possible Causes	Corrective Actions
Not enough heat	<ol style="list-style-type: none"> 1. Incorrect gas input. 2. Heater undersized. 3. Thermostat malfunction. 4. Heater cycling on limit control. 5. Check outside dampers if used. 	<ol style="list-style-type: none"> 1. Refer to operation. 2. This is especially true when the heated space is enlarged. Have the heat loss calculated and compare to the heater output (81% of input). Your gas supplier or installer can furnish this information. If heater is undersized, add additional heaters. 3. Replace thermostat. 4. Check air movement through heat exchanger. Check voltage to power venter motor, clean power venter wheel and heat exchanger, and oil power venter motor. Check filters, replace if necessary. 5. Adjust dampers accordingly.
Too much heat	<ol style="list-style-type: none"> 1. Thermostat malfunction. 2. Heater runs continuously. <ol style="list-style-type: none"> a. Improper thermostat or transformer wiring at gas valve. b. Short circuit. c. Defective or sticking gas valve. d. Excessive gas supply pressure. 	<ol style="list-style-type: none"> 1. Replace thermostat. 2. <ol style="list-style-type: none"> a. Check wiring per diagrams. b. Check operation at valve. Look for short and correct (such as staples piercing thermostat wiring). c. Replace gas valve. d. Refer to operation.
Power venter motor will not start	<ol style="list-style-type: none"> 1. Lack of power at unit. 2. Defective power venter relay. 3. Defective motor. 4. Thermostat not calling for heat. 5. Defective limit switch. 	<ol style="list-style-type: none"> 1. Replace fuse or turn on power. 2. Replace. 3. Replace. 4. Turn up thermostat. 5. Replace limit switch.
Noisy power venter	<ol style="list-style-type: none"> 1. Power venter wheel loose. 2. Bearings dry. 3. Power venter wheel blade dirty. 4. Power venter wheel rubbing housing. 	<ol style="list-style-type: none"> 1. Tighten or replace. 2. Oil bearings on power venter motor. 3. Clean power venter wheel blade. 4. Realign power venter wheel.
Power venter will not run	<ol style="list-style-type: none"> 1. Loose wiring. 2. Defective motor overload protector or defective motor. 3. Defective power venter relay. 	<ol style="list-style-type: none"> 1. Check and tighten all wiring connections per diagrams. 2. Replace motor. 3. Check for 24V across 1 & 3 terminals on fan relay. If 24V is present, jumper terminals numbered 2 and 4. If motor runs, relay is defective and must be replaced. If 24V is not present check wiring diagrams.
Power venter motor will not stop	<ol style="list-style-type: none"> 1. Improperly wired fan relay. 2. Defective fan relay. 	<ol style="list-style-type: none"> 1. Check all wiring. 2. Replace fan relay.



Gas Equipment Start-Up

Customer _____ Job Name & Number _____

PRE-INSPECTION INFORMATION

With power and gas off.

Type of Equip: Unit Heater Duct Furnace Indoor Rooftop

Serial Number _____ Model Number _____

Name Plate Voltage: _____ Name Plate Amperage: _____

Type of Gas: Natural LP Tank Capacity _____ lbs. Rating: _____ BTU @ _____ °F
_____ kg _____ kw @ _____ °C

- Are all panels and doors in place?
- Has the unit suffered any external damage? Damage _____
- Does the gas piping and electric wiring appear to be installed in a professional manner?
- Has the gas and electric been inspected by the local authority having jurisdiction?
- Is the gas supply properly sized for the equipment?
- Were the installation instructions followed when the equipment was installed?
- Have all field installed controls been installed?
- Do you understand all the controls on this equipment? If not, contact your wholesaler or rep.

(DO NOT START this equipment unless you fully understand the controls.)

GENERAL

With power and gas off.

- Make certain all packing has been removed.
- Tighten all electrical terminals and connections.
- Check damper linkages for tightness.
- Check all fans & blowers for free movement.
- Check all controls for proper settings.
- Check all set screws on blowers and bearings.
- Check belt tightness.

BLOWER

With power on and gas off.

- Check voltage L1 _____ L2 _____ L3 _____
- Check rotation of main blower.
- Check motor amps L1 _____ L2 _____ L3 _____
- Blower RPM _____
- Check air filters (Record quantity & size.)

GAS HEATING

With power and gas on.

- Inlet gas pressure. _____ in. W.C. or _____ kPa
- Pilot & main burner ignition.
- Manifold gas pressure. _____ in. W.C. or _____ kPa
- Cycle on HIGH LIMIT.
- Cycle firestat and/or freezestat.
- Check electronic modulation. Set at: _____
- Cycle and check all other controls not listed.
- Check operation of remote panel.
- Entering air temp. _____ °F or _____ °C
- Discharge air temp. (high fire) _____ °F. or _____ °C
- External static pressure _____ in. W.C. or _____ kPa
- Cycle by thermostat or operating control.
- Combustion Reading.
Carbon Monoxide _____ PPM
Carbon Dioxide _____ %



Notes



Trane - by Trane Technologies (NYSE: TT), a global innovator - creates comfortable, energy efficient indoor environments for commercial and residential applications. For more information, please visit trane.com or tranetechnologies.com.

Trane has a policy of continuous product and product data improvements and reserves the right to change design and specifications without notice. We are committed to using environmentally conscious print practices.

MUA-SVX004D-EN 11 Apr 2026
Supersedes MUA-SVX004C-EN (May 2022)

©2026 Trane