



Installation, Operation, and Maintenance

Outdoor Rooftop Evaporative

Cooling Units

For Heating, Cooling, and Ventilating Systems



J30-05817

⚠ SAFETY WARNING

Only qualified personnel should install and service the equipment. The installation, starting up, and servicing of heating, ventilating, and air-conditioning equipment can be hazardous and requires specific knowledge and training. Improperly installed, adjusted or altered equipment by an unqualified person could result in death or serious injury. When working on the equipment, observe all precautions in the literature and on the tags, stickers, and labels that are attached to the equipment.

April 2026

MUA-SVX002C-EN

TRANE
TECHNOLOGIES™



Introduction

Read this manual thoroughly before operating or servicing this unit.

If this unit is to be mated with a makeup air heating unit, be sure to read all applicable manuals, submittal/data sheets and all labels associated with the heating unit before attempting to install, operate, or service the Evaporative Cooling unit.

Warnings, Cautions, and Notices

Safety advisories appear throughout this manual as required. Your personal safety and the proper operation of this machine depend upon the strict observance of these precautions.

The three types of advisories are defined as follows:



Indicates a potentially hazardous situation which, if not avoided, could result in death or serious injury.



Indicates a potentially hazardous situation which, if not avoided, could result in minor or moderate injury. It could also be used to alert against unsafe practices.



Indicates a situation that could result in equipment or property-damage only accidents.

Important Environmental Concerns

Scientific research has shown that certain man-made chemicals can affect the earth's naturally occurring stratospheric ozone layer when released to the atmosphere. In particular, several of the identified chemicals that may affect the ozone layer are refrigerants that contain Chlorine, Fluorine and Carbon (CFCs) and those containing Hydrogen, Chlorine, Fluorine and Carbon (HCFCs). Not all refrigerants containing these compounds have the same potential impact to the environment. Trane advocates the responsible handling of all refrigerants.

Important Responsible Refrigerant Practices

Trane believes that responsible refrigerant practices are important to the environment, our customers, and the air conditioning industry. All technicians who handle refrigerants must be certified according to local rules. For the USA, the Federal Clean Air Act (Section 608) sets forth the requirements for handling, reclaiming, recovering and recycling of certain refrigerants and the equipment that is used in these service procedures. In addition, some states or municipalities may have additional requirements that must also be adhered to for responsible management of refrigerants. Know the applicable laws and follow them.

⚠ WARNING

Proper Field Wiring and Grounding Required!

Failure to follow code could result in death or serious injury.

All field wiring MUST be performed by qualified personnel. Improperly installed and grounded field wiring poses FIRE and ELECTROCUTION hazards. To avoid these hazards, you MUST follow requirements for field wiring installation and grounding as described in NEC and your local/state/national electrical codes.

⚠ WARNING**Personal Protective Equipment (PPE) Required!**

Failure to wear proper PPE for the job being undertaken could result in death or serious injury.

Technicians, in order to protect themselves from potential electrical, mechanical, and chemical hazards, **MUST** follow precautions in this manual and on the tags, stickers, and labels, as well as the instructions below:

- Before installing/servicing this unit, technicians **MUST** put on all PPE required for the work being undertaken (Examples; cut resistant gloves/sleeves, butyl gloves, safety glasses, hard hat/bump cap, fall protection, electrical PPE and arc flash clothing). **ALWAYS** refer to appropriate Safety Data Sheets (SDS) and OSHA guidelines for proper PPE.
- When working with or around hazardous chemicals, **ALWAYS** refer to the appropriate SDS and OSHA/GHS (Global Harmonized System of Classification and Labelling of Chemicals) guidelines for information on allowable personal exposure levels, proper respiratory protection and handling instructions.
- If there is a risk of energized electrical contact, arc, or flash, technicians **MUST** put on all PPE in accordance with OSHA, NFPA 70E, or other country-specific requirements for arc flash protection, **PRIOR** to servicing the unit. **NEVER PERFORM ANY SWITCHING, DISCONNECTING, OR VOLTAGE TESTING WITHOUT PROPER ELECTRICAL PPE AND ARC FLASH CLOTHING. ENSURE ELECTRICAL METERS AND EQUIPMENT ARE PROPERLY RATED FOR INTENDED VOLTAGE.**

⚠ WARNING**Follow EHS Policies!**

Failure to follow instructions below could result in death or serious injury.

- All Trane personnel must follow the company's Environmental, Health and Safety (EHS) policies when performing work such as hot work, electrical, fall protection, lockout/tagout, refrigerant handling, etc. Where local regulations are more stringent than these policies, those regulations supersede these policies.
- Non-Trane personnel should always follow local regulations.

⚠ WARNING**Cancer and Reproductive Harm!**

This product can expose you to chemicals including lead and bisphenol A (BPA), which are known to the State of California to cause cancer and birth defects or other reproductive harm. For more information go to www.P65Warnings.ca.gov.

⚠ WARNING**Safety Hazard!**

Failure to follow instructions below could result in death or serious injury or property damage.

This unit is not to be used by persons (including children) with reduced physical, sensory, or mental capabilities, or lack of experience and knowledge, unless they have been given supervision or instruction concerning the use of the appliance by a person responsible for their safety.

Do not allow children to play or climb on the unit or to clean or maintain the unit without supervision.

⚠ WARNING**Risk of Illness!**

Failure to follow instructions below could result in severe illness.

Maintain water in sumps by proper microbicidal water treatment to minimize the risks of illness caused by Legionella Pneumophila (the bacteria that causes Legionnaire's Disease) and other bacteria. Refer to local codes regarding any additional treatment or restrictions regarding water supplies and usage.



Copyright

This document and the information in it are the property of Trane, and may not be used or reproduced in whole or in part without written permission. Trane reserves the right to revise this publication at any time, and to make changes to its content without obligation to notify any person of such revision or change.

Trademarks

All trademarks referenced in this document are the trademarks of their respective owners.

Revision History

Updates to figures and tables in the Performance and Specification chapter.



Table of Contents

- Receiving Instructions 6
- General Safety Information 7
- Performance and Specification Data 8
- Evaporative Cooler Parts and Identification 13
- Installation 14
 - Mounting to Roof 14
 - Connecting the Water Supply 14
 - Faucet Use 15
 - Adjusting the Water Level and Float Valve 15
 - Adjusting the Water Flow 15
 - Bleed-Off 16
 - Adjusting the Bleed-Off 16
- Electrical Connections 17
 - Optional Fill and Drain Kit 18
 - Grounding 18
 - Wiring Diagrams 18
- Maintenance 20
 - Maintenance Schedule 20
 - Changing the Media 21
 - Cleaning the Water Pump 21
 - Washing the Media 22
 - Washing the Inlet Filter 22
 - Cabinet Cleaning and Touch-Up 22
 - Winter Shut Down 23
- Roof Curb Kit — Part Number 0134-0212-01* 24



Receiving Instructions

Inspect shipment immediately after receiving to determine if any damage has occurred during shipment. If any damage is found, the consignee should sign the bill of lading, indicating such damage, and immediately file claim for damage with the transportation company.

Note: *This equipment has been tested and inspected. It has been shipped free from defects from our factory. However, during shipment and installation, problems such as loose wires, leaks or loose fasteners may occur. It is the installer's responsibility to inspect and correct any problems that may be found.*



General Safety Information

⚠ WARNING

Hazardous Service Procedures!

Failure to follow all precautions in this manual and on the tags, stickers, and labels could result in death or serious injury.

Technicians, in order to protect themselves from potential electrical, mechanical, and chemical hazards, **MUST** follow precautions in this manual and on the tags, stickers, and labels, as well as the following instructions: **Unless specified otherwise, disconnect all electrical power including remote disconnect and discharge all energy storing devices such as capacitors before servicing. Follow proper lockout/tagout procedures to ensure the power can not be inadvertently energized. When necessary to work with live electrical components, have a qualified licensed electrician or other individual who has been trained in handling live electrical components perform these tasks.**

Unless otherwise specified, the following conversions may be used for calculating SI unit measurements:

- 1 inch = 25.4 mm
- 1 foot = 0.305 m
- 1 gallon = 3.785 L
- 1 pound = 0.454 kg
- 1 psig = 6.894 kPa
- 1 cubic foot = 0.028 m³
- 1000 Btu/Cu. Ft. = 37.5 MJ/m³
- 1000 Btu per hour = 0.293 kW
- 1 inch water column = 0.249 kPa
- liter/second = CFM x 0.472
- meter/second = FPM ÷ 196.8



Performance and Specification Data

Figure 1. Evaporative cooling units

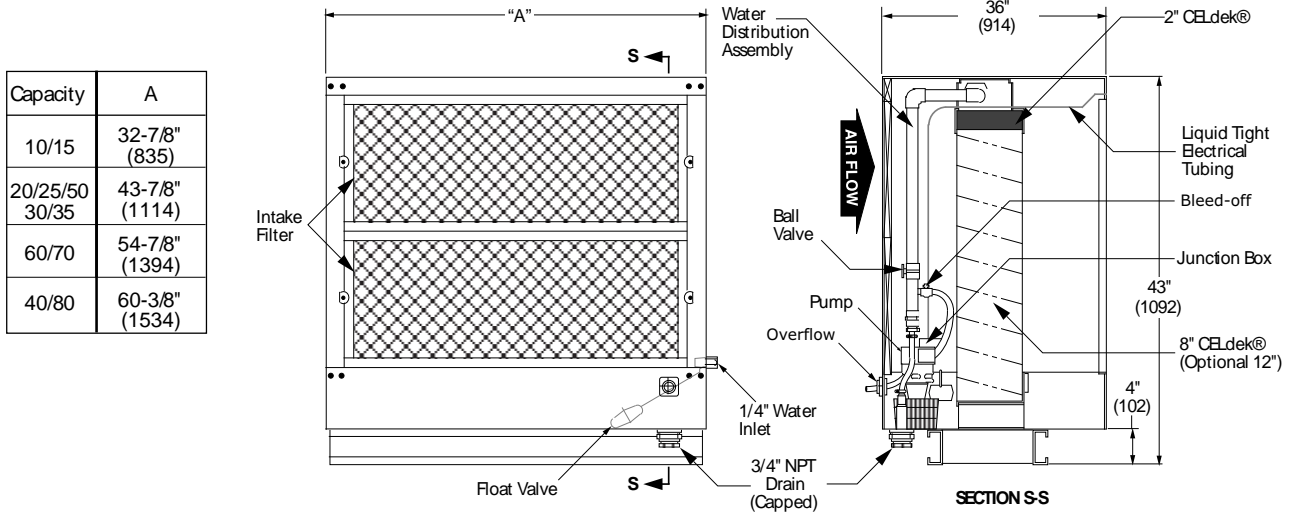

| Capacity | A |
|-------------------|----------------|
| 10/15 | 32-7/8" (835) |
| 20/25/50 30/35 | 43-7/8" (1114) |
| 60/70 | 54-7/8" (1394) |
| 40/80 | 60-3/8" (1534) |

Table 1. Performance and dimensional data

| Capacity ^(a) | CFM | | 8-in. Saturation Efficiency Range | | 12-in. Saturation Efficiency Range | | 8-in. or 12-in. Media | | Pressure Drop in W.C. | | "A" Unit Width in. (mm) | Shipping Wt. lb. (kg) | Operating Wt. lb. (kg) |
|-------------------------|------------------|------------------|-----------------------------------|-----|------------------------------------|-----|--|------------------------------|-----------------------|----------------|-------------------------|-----------------------|------------------------|
| | (cu. m/s) MIN | (cu. m/s) MAX | MIN | MAX | MIN | MAX | Face Area ft. ² (m ²) | Size in. (mm) | (kPA) MIN | (kPA) MAX | | | |
| 10, 15 | 800 (0.378) | 4,500 (2.124) | 78 | 88 | 89 | 92 | 7.01 (0.65) | 31 x 32-9/16 (787 x 827) | 0.03 (0.01) | 0.23 (0.06) | 32-3/4 (832) | 137 (62) | 301 (136) |
| 20, 25, 50 | 1,600 (0.755) | 5,500 (2.596) | 77 | 88 | 88 | 92 | 9.38 (0.87) | 31 x 43-9/16 (787 x 1106) | 0.03 (0.01) | 0.20 (0.05) | 43-3/4 (1111) | 166 (75) | 386 (175) |
| 30, 35, 60, 70 | 2,400 (1.133) | 8,500 (4.012) | 77 | 86 | 88 | 92 | 11.75 (1.09) | 31 x 54-9/16 (787 x 1386) | 0.05 (0.01) | 0.30 (0.07) | 54-3/4 (1391) | 192 (87) | 468 (212) |
| 40, 80 | 3,200 (1.510) | 8,500 (4.012) | 77 | 86 | 87 | 92 | 12.92 (1.20) | 31 x 60 (787 x 1524) | 0.07 (0.02) | 0.28 (0.07) | 60-1/4 (1530) | 206 (93) | 509 (231) |

^(a) (50, 60, 70 and 80) are for Dual Furnace Unit Types only.

CELdek® EVAPORATIVE MEDIA The Evaporative Cooler utilizes high efficiency CELdek media. CELdek is made from a special cellulose paper, impregnated with insoluble anti-rot salts and rigidifying saturants. The cross fluted design of the pads induces highly-turbulent mixing of air and water for optimum heat and moisture transfer. The evaporative coolers are available with standard 8 or optional 12 inch media which produce high efficiency and high face velocities, along with a 2" distribution pad to disperse the water evenly over the pads.

Figure 2. Pressure drop and evaporative cooling efficiency

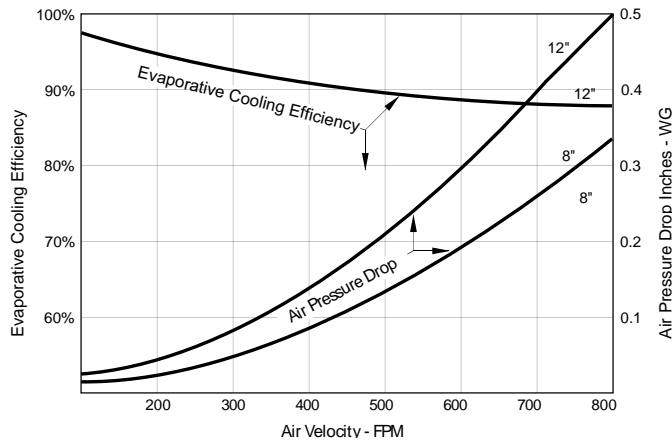

Figure 3. Power vent rooftop unit with evaporative cooler (without supply plenum)

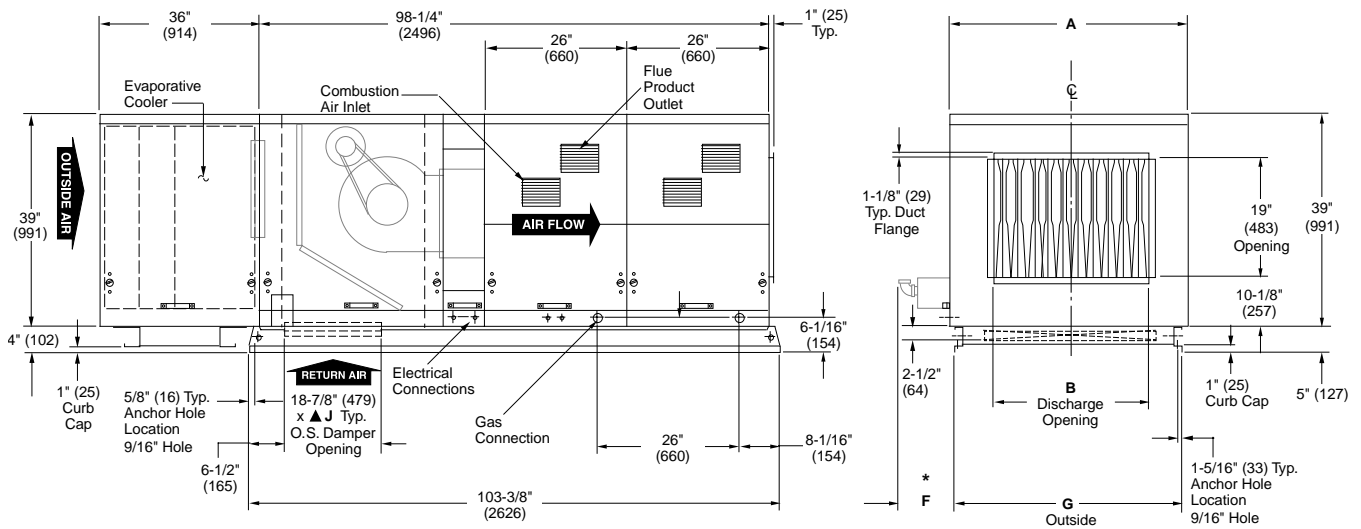

Table 2. Dimensions for power vent rooftop unit with evaporative cooling (without supply plenum)

| CAPACITY | A | B | F ^(a) | G | ▲ J ^(b) | GAS INLET | |
|----------|------------------|-------------------|------------------|-------------------|--------------------|-----------|-----|
| | | | | | | NAT | LP |
| 10 | 32-7/8 (835) | 15-9/16 (395) | 19- 3/8 (492) | 31-1/16 (789) | 24 (610) | 1/2 | 1/2 |
| 15 | 32-7/8 (835) | 18-5/16 (465) | 23-1/2 (597) | 31-1/16 (789) | 24 (610) | 1/2 | 1/2 |
| 20 | 43-7/8 (1114) | 23-13/16 (605) | 26-1/4 (667) | 42-1/16 (1068) | 35 (889) | 1/2 | 1/2 |
| 25 | 43-7/8 (1114) | 29-5/16 (745) | 34-1/2 (876) | 42-1/16 (1068) | 35 (889) | 3/4 | 3/4 |
| 30 | 54-7/8 (1394) | 34-13/16 (884) | 37-1/4 (946) | 53-1/16 (1348) | 46 (1168) | 3/4 | 3/4 |



Performance and Specification Data

Table 2. Dimensions for power vent rooftop unit with evaporative cooling (without supply plenum) (continued)

| CAPACITY | A | B | F ^(a) | G | ▲ J ^(b) | GAS INLET | |
|----------|------------------|--------------------|------------------|-------------------|--------------------|-----------|-----|
| | | | | | | NAT | LP |
| 35 | 54-7/8 (1394) | 40-5/16 (1024) | 45-1/2 (1156) | 53-1/16 (1348) | 46 (1168) | 3/4 | 3/4 |
| 40 | 60-3/8 (1534) | 45-13/16 (1164) | 51 (1295) | 58-9/16 (1487) | 51-1/2 (1308) | 3/4 | 3/4 |
| 50 | 43-7/8 (1114) | 29-5/16 (745) | 34-1/2 (876) | 42-1/16 (1068) | 35 (889) | 3/4 | 3/4 |
| 60 | 54-7/8 (1394) | 34-13/16 (884) | 37-1/4 (946) | 53-1/16 (1348) | 46 (1168) | 3/4 | 3/4 |
| 70 | 54-7/8 (1394) | 40-5/16 (1024) | 45-1/2 (1156) | 53-1/16 (1348) | 46 (1168) | 3/4 | 3/4 |
| 80 | 60-3/8 (1534) | 45-13/16 (1164) | 51 (1295) | 58-9/16 (1487) | 51-1/2 (1308) | 3/4 | 3/4 |

Note: Refer to unit submittals for more specifications/unit arrangements. Dimensions are inches, dimensions in parentheses are in millimeters.

- (a) "F" dimension is the recommended clearance to service the burner drawer(s).
- (b) "J" dimension is an outside dimension for return air dampers.

Figure 4. Power vent rooftop unit with evaporative cooler (with supply plenum)

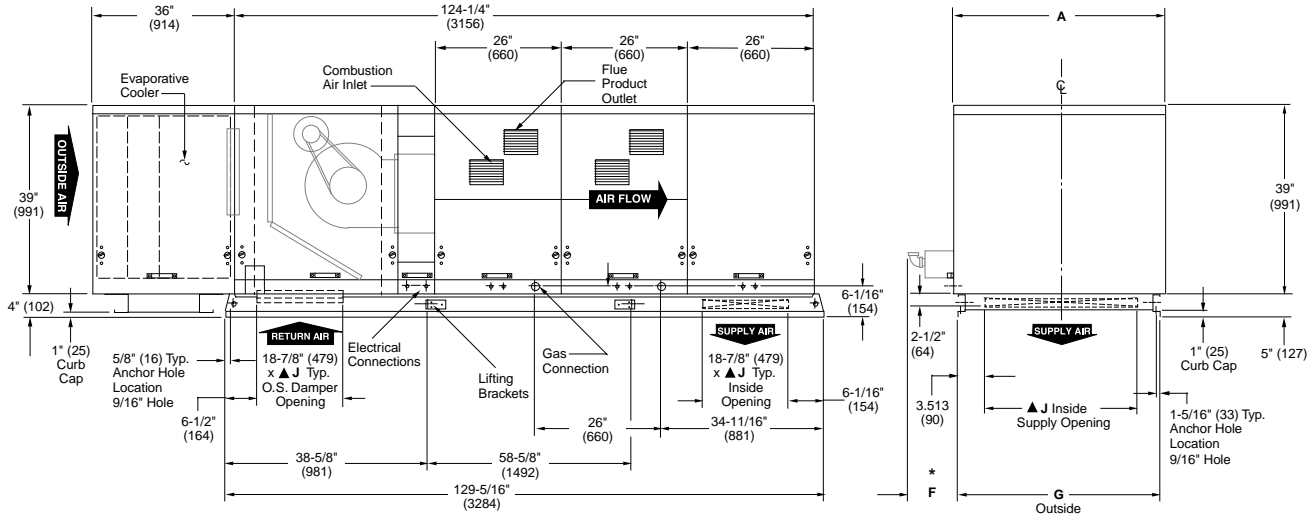

Table 3. Dimensions for power vent rooftop unit with evaporative cooling (with supply plenum)

| CAPACITY | A | B | F ^(a) | G | ▲ J ^(b) | GAS INLET | |
|----------|-----------------|------------------|------------------|------------------|--------------------|-----------|-----|
| | | | | | | NAT | LP |
| 10 | 32-7/8 (835) | 15-9/16 (395) | 19-3/8 (492) | 31-1/16 (789) | 24 (610) | 1/2 | 1/2 |
| 15 | 32-7/8 (835) | 18-5/16 (465) | 23-1/2 (597) | 31-1/16 (789) | 24 (610) | 1/2 | 1/2 |

Table 3. Dimensions for power vent rooftop unit with evaporative cooling (with supply plenum) (continued)

| CAPACITY | A | B | F ^(a) | G | ▲J ^(b) | GAS INLET | |
|----------|------------------|--------------------|------------------|-------------------|-------------------|-----------|-----|
| | | | | | | NAT | LP |
| 20 | 43-7/8 (1114) | 23-13/16 (605) | 26-1/4 (667) | 42-1/16 (1068) | 35 (889) | 1/2 | 1/2 |
| 25 | 43-7/8 (1114) | 29-5/16 (745) | 34-1/2 (876) | 42-1/16 (1068) | 35 (889) | 3/4 | 3/4 |
| 30 | 54-7/8 (1394) | 34-13/16 (884) | 37-1/4 (946) | 53-1/16 (1348) | 46 (1168) | 3/4 | 3/4 |
| 35 | 54-7/8 (1394) | 40-5/16 (1024) | 45-1/2 (1156) | 53-1/16 (1348) | 46 (1168) | 3/4 | 3/4 |
| 40 | 60-3/8 (1534) | 45-13/16 (1164) | 51 (1295) | 58-9/16 (1487) | 51-1/2 (1308) | 3/4 | 3/4 |
| 50 | 43-7/8 (1114) | 29-5/16 (745) | 34-1/2 (876) | 42-1/16 (1068) | 35 (889) | 3/4 | 3/4 |
| 60 | 54-7/8 (1394) | 34-13/16 (884) | 37-1/4 (946) | 53-1/16 (1348) | 46 (1168) | 3/4 | 3/4 |
| 70 | 54-7/8 (1394) | 40-5/16 (1024) | 45-1/2 (1156) | 53-1/16 (1348) | 46 (1168) | 3/4 | 3/4 |
| 80 | 60-3/8 (1534) | 45-13/16 (1164) | 51 (1295) | 58-9/16 (1487) | 51-1/2 (1308) | 3/4 | 3/4 |

Note: Refer to unit submittals for more specifications/unit arrangements. Dimensions are inches, dimensions in parentheses are in millimeters.

(a) "F" dimension is the recommended clearance to service the burner drawer(s).

(b) "J" dimension is an outside dimension for return air dampers, and an inside dimension for supply air (without damper).

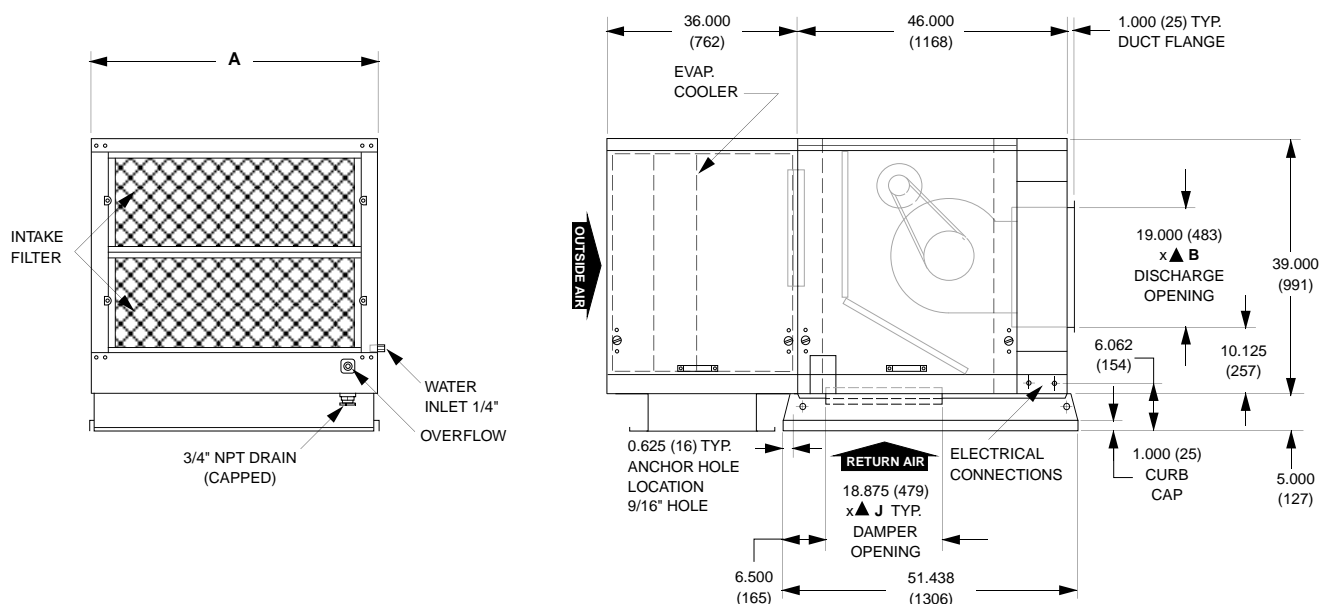
Figure 5. Standard air handler with evaporative cooling (without supply plenum)



Performance and Specification Data

Table 4. Dimensions for standard air handler with evaporative cooler (with or without supply plenum)

| CAPACITY | A | B | C | G | ▲ J ^(a) |
|----------|------------------|--------------------|--------------------|-------------------|--------------------|
| 20 | 43 7/8 (1114) | 23-13/16 (605) | 21- 15/16 (557) | 42-1/16 (1068) | 35 (889) |
| 40 | 60-3/8 (1534) | 45-13/16 (1164) | 30-3/16 (767) | 59-9/16 (1487) | 52-1/2 (1308) |

Note: Refer to unit submittals for more specifications/unit arrangements. Dimensions are inches, dimensions in parentheses are in millimeters.

^(a) "J" dimension is an outside dimension for return air dampers and an inside opening for supply air (without dampers).

Figure 6. Standard air handler with evaporative cooling (with supply plenum)

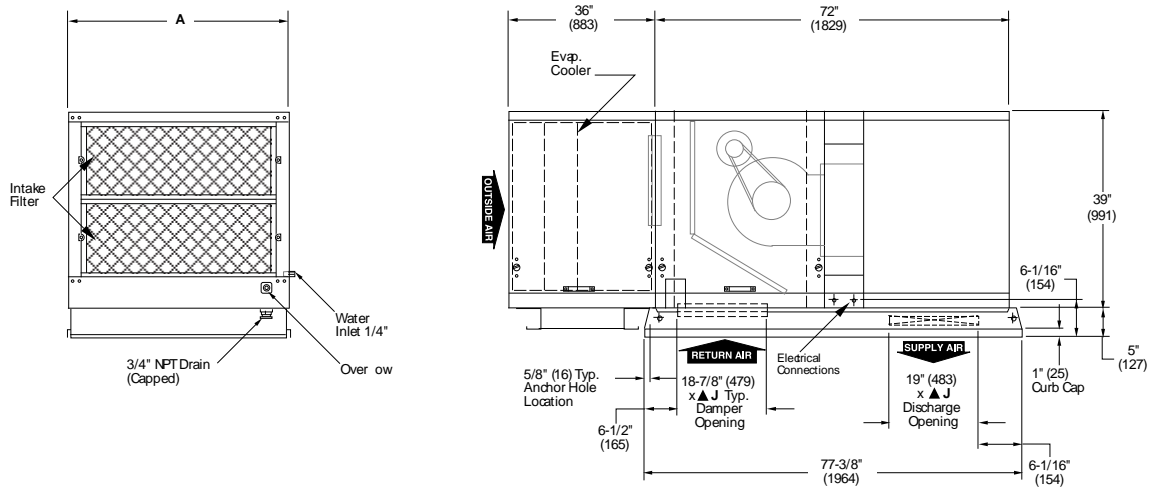



Evaporative Cooler Parts and Identification

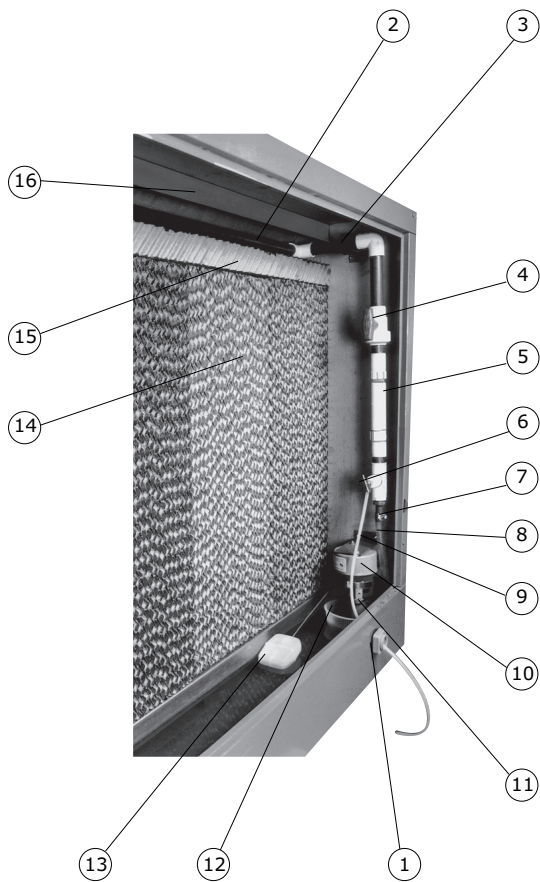

1. Bulk Head Fitting (Drain Overflow)
2. Water Distribution Assembly
3. Clip Assembly (Water Distribution Assembly)
4. Ball Valve
5. Line Filter
6. Brass Needle Cock Valve
7. Worm Clamp
8. PVC Flexible Hose
9. Pump Support Bracket
10. Pump
11. Poly Tubing — 1/4" O.D.
12. Pump Basket Screen
13. Float Valve
14. Media Pad (8" or Opt. 12" W)
15. Media Distribution Pad (2" x 8" x L or 2" x 12" x L)
16. Hood Water Distribution



Installation

Note: This manual is for Evaporative Cooler Module Installations only. Refer to the Installation and Service Manuals for Rooftop Packaged Units and Outdoor Furnaces for these unit installations.

⚠ WARNING

Risk of Roof Collapsing!

Failure to ensure proper structural roof support could cause the roof to collapse, which could result in death or serious injury and property damage.

Confirm with a structural engineer that the roof structure is strong enough to support the combined weight of the roofcurb, the unit, and any accessories.

Mounting to Roof

1. Before positioning the unit in its permanent location, make certain that the roof is capable of carrying the load of this equipment. Note that when the cooler is filled with water, the unit will be much heavier than when dry. See "Performance and Dimension Data" table for appropriate operating weight.
2. If unit is to be mounted on a curb, refer to the curb specifications for installation requirements.
3. Make certain that the mounting surface is level in all directions.
4. Make certain that you have sufficient means for lifting the unit into place.
5. Installation must conform to local and national building and safety codes.
6. The units are mounted on skid rails and are suitable for use on combustible flooring. It is recommended that the skids be mounted either on solid planking or on steel channels, but never on a soft tar roof where the skids could sink and reduce the 4" clearance between the bottom pan and the roof.
7. Inspect all internal parts of the cooler section to determine if any damage has occurred during shipment. See roof curb specifications at the end of the manual.

Connecting the Water Supply

NOTICE

Cooler Damage!

Failure to follow instruction below could result in cooler damage from corrosion.

Do not attach soft water equipment to water lines going to the cooler.

1. A water valve should be installed at a convenient location to allow water to be turned on and off. Use 1/4" tubing to supply water to Evaporative Cooler. A water connector kit is available at your local wholesaler.
2. Place tube nut and ferrule over the end of the tubing.
3. Insert tubing into factory-installed float valve and tighten securely.

Figure 7. Float valve assembly

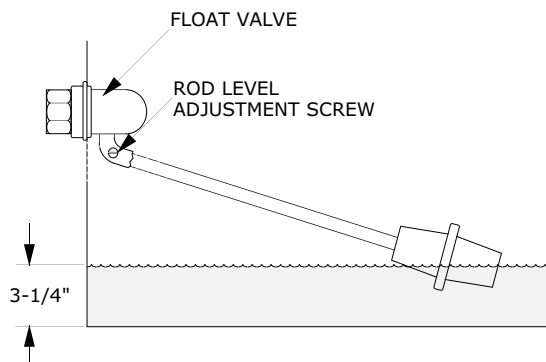

Note: There will be a slight odor during the initial start-up of the unit. The odor will disappear within the first few days of operation if the bleed-off is adjusted correctly.

Faucet Use

1. To connect the water line to the water supply, install a sillcock and water valve on the faucet.
2. Place tubing nut and ferrule on tube end, and insert valve.
3. Tighten the nuts on the valve and the tube.

Note: If a faucet is not to be used for the water supply, install the valve on the water line to be used. Follow the procedure above for securing the tubing to the valve.

Figure 8. Evaporative cooler water connections

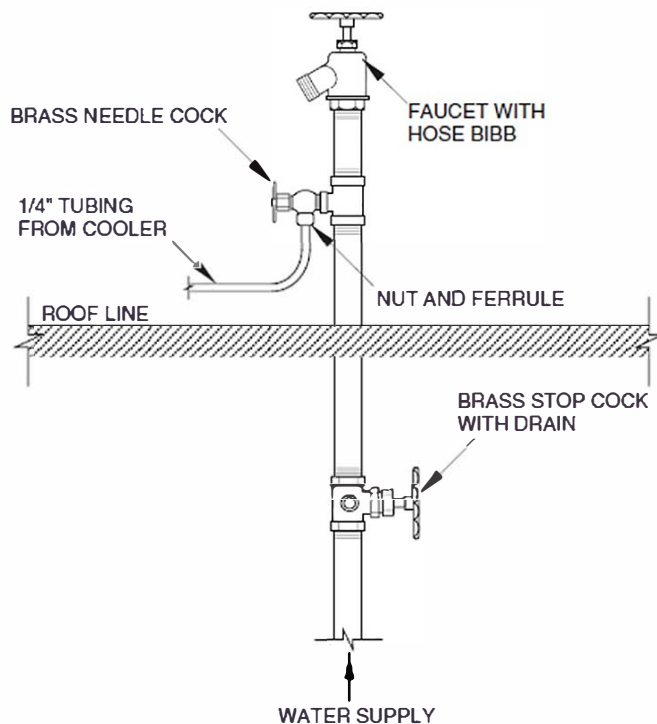

Adjusting the Water Level and Float Valve

Fill the tank as follows:

1. Turn the water supply on. Fill the tank to a depth of approximately 3.25" (82.6 mm). While filling the tank, check for good pressure and flow from the float valve.
2. The float valve should shut down the water supply at the 3.25" (82.6 mm) level. It may be necessary to adjust the float valve by bending the rod. The rod level adjustment screw should be set in lower notch on lever.
3. Check the tank and all connections for leaks.

Note: The overflow fitting is set so that the water will begin to flow at the 3.25" (82.6 mm) depth. It is important that the water level not be above the pump basket screen!

Adjusting the Water Flow

Proper water flow over the media is important. Insufficient water flow will result in increased accumulation of minerals on the media. Excessive water flow will result in deterioration of the media and moisture carryover.

1. Using the ball valve handle, adjust the water flow so that the media is damp from the top to the bottom. If you can see water flowing on the entering side, your water level is too high. Adjust the valve so that the media is just damp on the entering side. Repeated drying of the media will cause rapid buildup of mineral deposits in the media. Drying is due to improper adjustment



Installation

of the water flow valve, frequent shut-down of the pump to control the evaporative cooling/humidification, or localized air velocities across the surface of the media. The area where dry spots occur will exhibit high mineral deposits. The valve must be adjusted so that no dry spots appear on entering or leaving side, and when adjusted correctly, enough water will flow through the media to wash out most of the airborne dirt and other debris.

2. Prior to start-up, it is recommended that the tank be filled, and the pump turned on, allowing the unit to run for approximately 10 minutes. Repeat this procedure two times to help flush any dirt that may have accumulated during shipping.

Bleed-Off

Bleed-Off is required to maintain the water quality of the system. When water evaporates, minerals and other impurities are left behind, impurities are scrubbed from the air flowing through the system, and make-up water (even good quality make-up water) adds more minerals and impurities. These form deposits on the media during the evaporative process. Therefore, it is important to bleed-off a small quantity of recirculating water to keep the concentration of impurities under control. The bleed-off rate required is dependent upon the quality of the water used and the rate of evaporation. As climate conditions change, the rate of evaporation may increase, requiring an increase in the bleed-off rate. It is recommended that the bleed-off rate be adjusted for the maximum water evaporation. An indication of insufficient bleed-off is a uniform build-up of minerals on the entering air face of the media. If this condition is observed, increase the rate of bleed-off until the mineral deposits dissipate.

Adjusting the Bleed-Off

1. The bleed-off is attached to the PVC tee. This bleed-off system will eliminate a small quantity of water from recirculation, which will reduce scale build-up. This water will drain through the attached tube, and out through the overflow. Disposal of this water should comply with local codes.
2. Adjust the bleed-off rate according to Table 5.

Table 5. Bleed-off rate table

| Unit Size Capacity | Seconds to Fill 12 oz. Can | |
|-----------------------|-------------------------------|----|
| | 10/15 | 69 |
| 20/25/50 | 52 | 34 |
| 30/35/60/70 | 41 | 27 |
| 40/80 | 38 | 25 |



Electrical Connections

⚠ WARNING

Hazardous Voltage!

Failure to disconnect power before servicing could result in death or serious injury.

Disconnect all electric power, including remote disconnects before servicing. Follow proper lockout/tagout procedures to ensure the power can not be inadvertently energized. Verify that no power is present with a voltmeter.

⚠ WARNING

Proper Field Wiring and Grounding Required!

Failure to follow code could result in death or serious injury.

All field wiring **MUST** be performed by qualified personnel. Improperly installed and grounded field wiring poses **FIRE** and **ELECTROCUTION** hazards. To avoid these hazards, you **MUST** follow requirements for field wiring installation and grounding as described in NEC and your local/state/national electrical codes.

Refer to the unit data plate to determine the supply voltage.

The motor name-plate and electrical rating on the transformer should be checked before energizing the unit electrical system. All external wiring must conform to ANSI/NFPA No. 70-1996, National Electrical Code (or the latest edition of) and applicable local codes; in Canada, to the Canadian Electrical Code, Part 1 CSA Standard C22.1

"Dashed" lines represent either field wiring (by others) or optional equipment. Refer to optional items (shown on wiring diagram included with unit) - these will be hard wired.

⚠ WARNING

Fire Hazard!

Failure to follow instructions below could cause a fire which could result in death or serious injury, and property damage.

DO NOT jumper factory wiring! Mis-wiring of safety circuits could cause a fire. For all wiring connections, refer to the wiring diagram shipped with the unit. Should any original wire supplied with the unit have to be replaced, it **MUST** be replaced with wiring material having a temperature rating of at least 221°F (105°C).

⚠ WARNING

Risk of Electrocution!

Failure to follow instructions below could result in death or serious injury.

DO NOT use any tools (i.e. screwdriver, pliers, etc.) across the terminals to check for power. You **MUST** use a CAT III or IV voltmeter rated per NFPA 70E.

NOTICE

Use Copper Conductors Only!

Failure to use copper conductors could result in equipment damage as the equipment was not designed or qualified to accept other types of conductors.

Important: For all wiring connections, refer to the wiring diagram shipped with the unit (either affixed to the side jacket or enclosed in the unit's installation instruction envelope). Should any original wire supplied with the unit have to be replaced, it must be replaced with wiring material having a temperature rating of at least 105°C.

It is recommended that the electrical power to each unit be provided by a separate, fused, and permanently live electrical circuit. A disconnect switch of suitable electrical rating for each unit should be placed as close to the controls as possible. Each unit must be electrically grounded in accordance with the latest edition of the National Electrical Code, ANSI/NFPA No. 70-1996, or CSA Standard C22.1. Sample wiring connections are depicted in Figures 9 & 10.

Note: Consult the factory before making any changes to factory wiring.

Optional Fill and Drain Kit

Optional Evaporative Cooler Fill and Drain Kit consists of two motorized valves, installed in the building, and piped and wired to the roof. The kit eliminates the need to go to the roof to fill or drain the cooler for seasonal changeover, and automatically maintains the water level. See sample Figure 10. Refer to the kit's instruction.

Grounding

Install a ground wire to suitable ground according to local codes.

Wiring Diagrams

Figure 9. Typical evaporative cooler control wiring

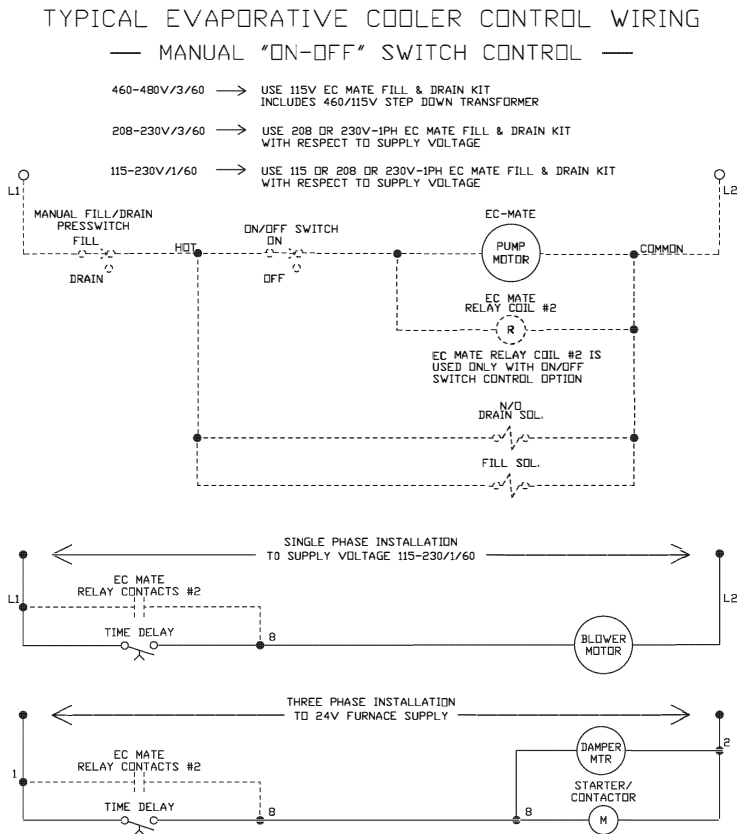

- * CAUTION- DISCONNECT POWER BEFORE SERVICING.
- * UNIT MUST BE GROUNDED.
- * USE COPPER CONDUCTORS ONLY.
- * IF ANY OF THE ORIGINAL WIRE AS SUPPLIED WITH THE APPLIANCE MUST BE REPLACED, IT MUST BE REPLACED WITH WIRING MATERIAL HAVING A TEMPERATURE RATING OF AT LEAST 125° C.
- * REFER TO INSTALLATION INSTRUCTIONS FOR VENTING GAS PIPING AND START-UP PROCEDURES.

| | |
|--|-----------------------|
| LEGEND | ----- BY MANUFACTURER |
| | ----- BY OTHERS |
| DIAGRAM RECORD- | DATE: 9/1/89 |
| MANUAL "ON-OFF" SWITCH CONTROL | BY: SKL |
| WITH FILL & DRAIN KIT | REV. # 00.00 |
| | FILE # EC-W1 |
| DIAGRAM NO. EC MATE COMMON WIRING ARRANGEMENTS | |

Figure 10. Optional fill and drain kit

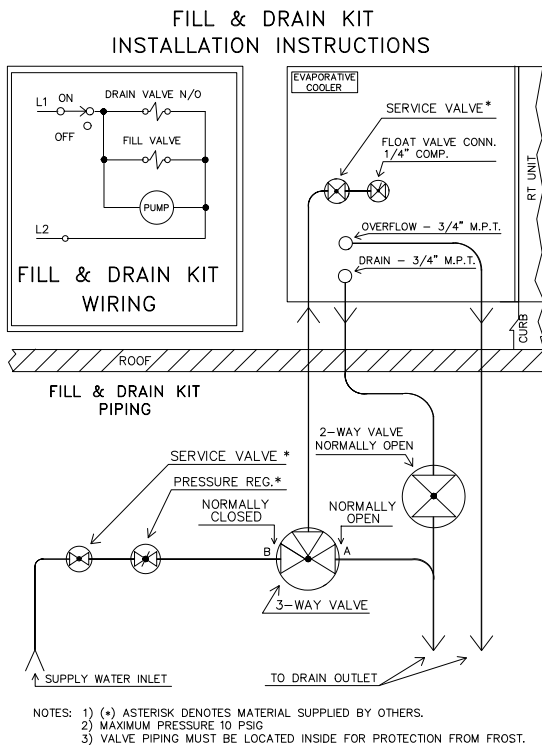



Maintenance

⚠ WARNING

Hazardous Voltage!

Failure to disconnect power before servicing could result in death or serious injury.

Disconnect all electric power, including remote disconnects before servicing. Follow proper lockout/tagout procedures to ensure the power can not be inadvertently energized. Verify that no power is present with a voltmeter.

Because of the nature of the evaporative process, algae buildup, biological fouling, scale build-up, and corrosion are distinct possibilities. Proper water treatment and regularly scheduled maintenance will minimize or eliminate most problems.

1. Cooling Pad Check List:

- Reduce the number of on/off cycles.
- Shade the pads and pump.
- Dry pads out completely once every 24 hours.
- Maintain a suitable water bleed-off rate.
- Drain and disinfect the entire water system quarterly.
- Avoid harmful contaminants, including dust, fumes, harsh cleaners, and water treatment chemicals.
- Circulate the recommended quantity of water over the pads.
- Avoid dry areas on the pads.
- Clean the filters regularly.

2. Controlling Algae:

- Scale and mineral deposits can form on the cooling pad because the mineral content of the water is too high.
- Increase the water flow over the face of the pads.
- Make certain that the flow of water is even from one end of the distribution pipe to the other end.
- Clean and flush the distributor pipe regularly; especially if dry areas appear on the pads.
- Maintain the pH of the recirculating water between 6 and 8.
- Maintain sufficient bleed-off rate.

For more details, check MUNTERS® Engineering Bulletin EB-WTM-502.

3. Preventing Algae in the Evaporative Pads:

- Algae needs light, moisture, and nutrients to survive. Eliminating, or reducing, these elements will help to control algae. For specific details, see MUNTERS® Engineering Bulletin EB-WTM-502.

4. Biological Fouling Control:

- Uncontrolled growth of organic matter can lead to plugged media, metal deterioration, and biological contamination of the airstream. Whenever the possibility of biological contamination of water in an airstream exists, transmittal of Legionnaire's Disease should be addressed. While there are no reported cases of Legionnaire's Disease associated with rigid media type evaporative cooling systems, the Legionella Pneumophila bacteria is present in almost all water supplies. However, the mere presence of the bacteria does not create a hazard: the bacteria must be transmitted as an aerosol in sufficient densities to be infectious.

Note: It is highly recommended that the services of a water treatment company be retained to advise on the proper treatment of the sump water for biological, scale, and corrosion control. For more information, see MUNTERS® Engineering Bulletin EB-WTM-502.

Maintenance Schedule

Regular maintenance is the key to successful service from your Evaporative Cooler. Use the following schedule as a guide to maintain your unit:

Table 6. Maintenance schedule

| Maintenance Requirements | Annual Start-Up | Annual Shutdown |
|--------------------------------|---|---------------------------|
| Changing Media | At beginning of 6th year or if passages are blocked | |
| Water Pump Cleaning | X | |
| Cleaning & Touch-Up | | X |
| Adjusting Bleed-Off | X | |
| Periodic Inspection | During cooling season | During cooling season |
| Washing Down Media with Hose | | As required during season |
| Inlet Filter Washing with Hose | X | X |
| Drain Unit | | X |

Note: The procedures in the Maintenance Schedule are explained in the following sections.

Changing the Media

This should be done every 5 years or if passages become blocked.

1. Remove filter/frame assemblies.
2. Disconnect the water hood panel from the top panel by removing screws.
3. Snap out water distribution system.
4. Remove top media distribution pad.
5. Lift out media sections (Note the position of media with respect to airflow. See [Figure 11, p. 21](#))
6. Replace with new CELdek® media sections. (See “[Evaporative Cooler Parts and Identification](#),” p. 13). Aspen and other evaporative media will not work.
7. When re-installing media, be sure all media sections are installed in the proper direction. See [Figure 11, p. 21](#)
8. Replace top media distribution pad, water distribution system, water hood panel, and filter/frame assemblies.

Figure 11. Evaporative cooling media pad section

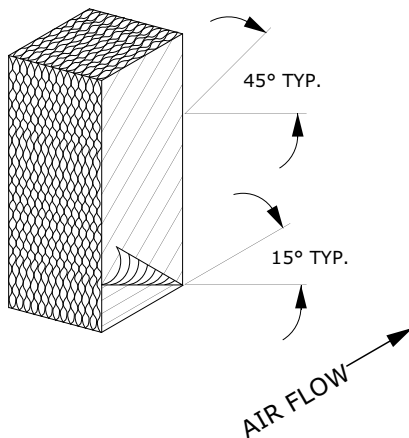

Cleaning the Water Pump

NOTICE

Pump Damage!

Water will damage the pump motor as this is not a submersible pump.
Do not allow the pump to topple over or become submerged.



Maintenance

Disassemble and clean water pump as follows:

⚠ WARNING

Hazardous Voltage!

Failure to disconnect power before servicing could result in death or serious injury.

Disconnect all electric power, including remote disconnects before servicing. Follow proper lockout/tagout procedures to ensure the power can not be inadvertently energized. Verify that no power is present with a voltmeter.

1. Disconnect Power.
2. Disconnect the liquid tight connector from the junction box to remove cord and connector.
3. Disconnect the pump mounting bracket and hose.
4. Remove the pump and basket screen.
5. To clean pump, snap out base of the pump; notice the impeller.
6. Using a mild detergent solution, wash all deposits from the impeller and the impeller base plate.
7. Spin the impeller to dislodge any foreign material. Make sure that the impeller spins freely.
8. Carefully snap the impeller and impeller base plate back onto the pump.
9. Wash the pump basket screen using the same detergent solution, and rinsing thoroughly to remove any debris. If unable to clean, replace with a new screen (See replacement part section).

Note: The pump motor does not require any lubrication.

Washing the Media

NOTICE

Blower Motor Damage!

Do not splash water on the blower motor as it could result in electrical shorts and blower motor damage.

1. Scale and dust should be washed off the intake side of the media annually, using a garden hose and nozzle; this will help to unclog passages.
2. Using a stiff brush, lightly brush the intake edges of the media. This will not harm the openings, but will remove any hardened scale.
3. Occasionally, there will be a build-up of algae or odors. The best solution for both of these problems is to allow the pads to dry thoroughly on a regular basis. If cooling is not needed at night during the cooling season, allow the blower to run for a few hours after the pump has been shut-down to dry pads daily.
4. During the cooling season, we recommend that the pads be shut down nightly if possible with the blower running to dry the pads out for a few hours before the unit is shut down.

Washing the Inlet Filter

The pre-filter should be cleaned periodically as follows:

1. Turn the four latches and remove filter frame assemblies.
2. Carefully remove the aluminum filters. Wash the filters with warm water and a mild soap, rinse thoroughly.
3. Re-install in unit.
4. If the aluminum mesh filters are damaged or cannot be cleaned, replace the mesh filter (See replacement parts section).

Cabinet Cleaning and Touch-Up

The cabinet and all internal parts of the Evaporative Cooler should be cleaned annually using a soft cloth, warm water, and a mild cleanser.

Note: Avoid using steel wool or sandpaper in normal cleaning of the unit.

Winter Shut Down

1. Clean and flush out Evaporative Cooler media and sump.
2. Clean water distributor holes.
3. Drain fill pipe and leave open. **DO NOT LEAVE ANY WATER IN THE SYSTEM. FREEZING CAN CAUSE MAJOR DAMAGE TO THE UNIT.**
4. Remove and clean pump if necessary.
5. Check sump tank for leaks and repair if necessary. Sump tank is fabricated from stainless steel.



Roof Curb Kit — Part Number 0134-0212-01*

For use with:
Evaporative Cooler Module
Capacities — 10/40
*Evaporative Cooler Platform Only

Figure 12. Evaporative cooler platform roof curb assembly

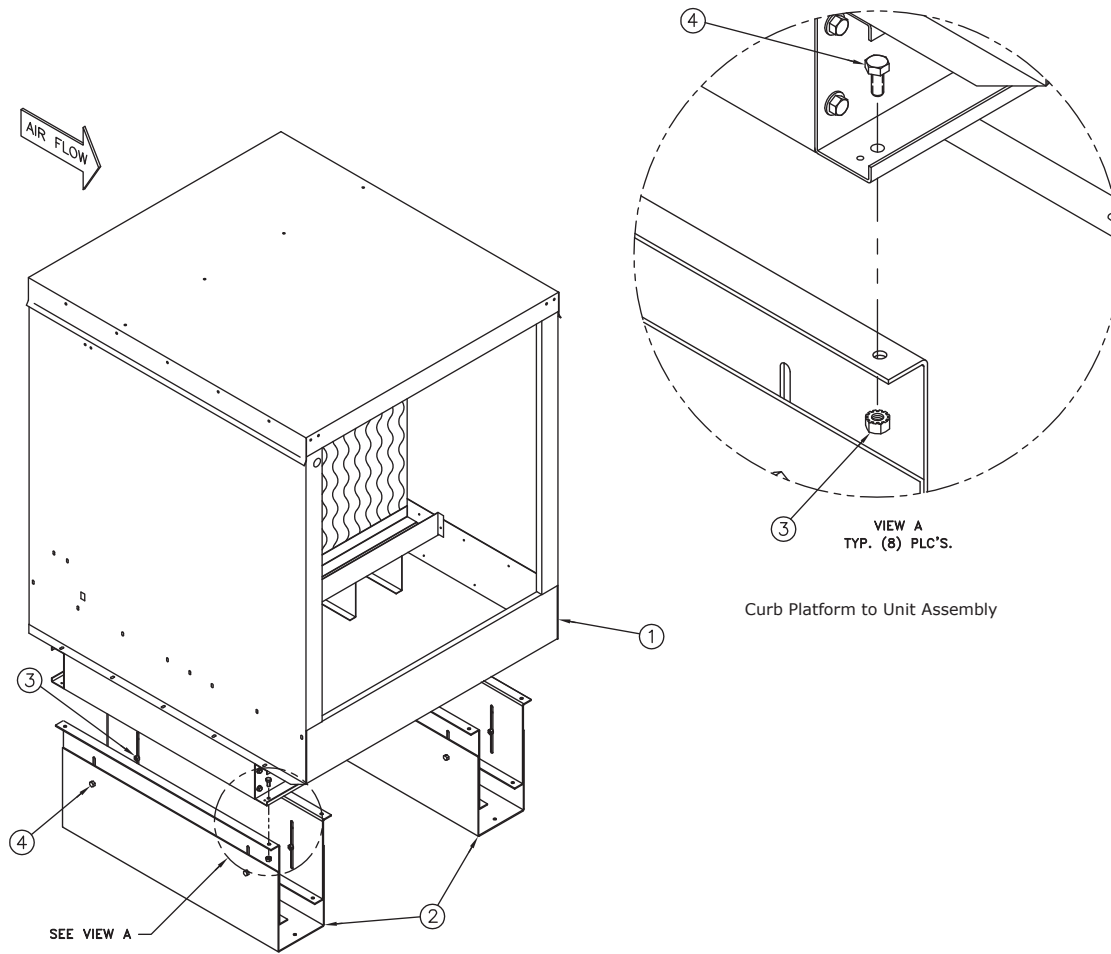

Roof Curb Kit 0134-0212-01
Contents:

- ① Evaporative Cooler Assembly (sold separately)
- ② Curb (2 platforms per kit)
- ③ 1/4-20 "KEPS" Nut (8) required
- ④ 1/4-20 x 5/8 LG. Hex HD. Bolt (8) required

Evaporative Cooler Platform Roof Curb Kit
Shipping Weight = Approx. 30 lbs. (13.6 kg)

Note: *One Platform Kit fits All Evaporative Cooler Modules/Capacities (CA) - 10/80



Notes

Trane - by Trane Technologies (NYSE: TT), a global innovator - creates comfortable, energy efficient indoor environments for commercial and residential applications. For more information, please visit trane.com or tranetechnologies.com.

Trane has a policy of continuous product and product data improvements and reserves the right to change design and specifications without notice. We are committed to using environmentally conscious print practices.

MUA-SVX002C-EN 11 Apr 2026
Supersedes MUA-SVX002B-EN (August 2020)

©2026 Trane