



Installation, Operation, and Maintenance

Agility™ Water-cooled Chillers

With Symbio™ Controls



Model: HDWA PC 747

X39641412003

⚠ SAFETY WARNING

Only qualified personnel should install and service the equipment. The installation, starting up, and servicing of heating, ventilating, and air-conditioning equipment can be hazardous and requires specific knowledge and training. Improperly installed, adjusted or altered equipment by an unqualified person could result in death or serious injury. When working on the equipment, observe all precautions in the literature and on the tags, stickers, and labels that are attached to the equipment.

September 2023

HDWA-SVX002C-EN

TRANE
TECHNOLOGIES



Introduction

Read this manual thoroughly before operating or servicing this unit.

Warnings, Cautions, and Notices

Safety advisories appear throughout this manual as required. Your personal safety and the proper operation of this machine depend upon the strict observance of these precautions.

The three types of advisories are defined as follows:



Indicates a potentially hazardous situation which, if not avoided, could result in death or serious injury.



Indicates a potentially hazardous situation which, if not avoided, could result in minor or moderate injury. It could also be used to alert against unsafe practices.



Indicates a situation that could result in equipment or property-damage only accidents.

Important Environmental Concerns

Scientific research has shown that certain man-made chemicals can affect the earth's naturally occurring stratospheric ozone layer when released to the atmosphere. In particular, several of the identified chemicals that may affect the ozone layer are refrigerants that contain Chlorine, Fluorine and Carbon (CFCs) and those containing Hydrogen, Chlorine, Fluorine and Carbon (HCFCs). Not all refrigerants containing these compounds have the same potential impact to the environment. Trane advocates the responsible handling of all refrigerants.

Important Responsible Refrigerant Practices

Trane believes that responsible refrigerant practices are important to the environment, our customers, and the air conditioning industry. All technicians who handle refrigerants must be certified according to local rules. For the USA, the Federal Clean Air Act (Section 608) sets forth the requirements for handling, reclaiming, recovering and recycling of certain refrigerants and the equipment that is used in these service procedures. In addition, some states or municipalities may have additional requirements that must also be adhered to for responsible management of refrigerants. Know the applicable laws and follow them.

⚠ WARNING

Proper Field Wiring and Grounding Required!

Failure to follow code could result in death or serious injury.

All field wiring **MUST** be performed by qualified personnel. Improperly installed and grounded field wiring poses **FIRE** and **ELECTROCUTION** hazards. To avoid these hazards, you **MUST** follow requirements for field wiring installation and grounding as described in **NEC** and your local/state/national electrical codes.

⚠ WARNING

Personal Protective Equipment (PPE) Required!

Failure to wear proper PPE for the job being undertaken could result in death or serious injury.

Technicians, in order to protect themselves from potential electrical, mechanical, and chemical hazards, **MUST** follow precautions in this manual and on the tags, stickers, and labels, as well as the instructions below:

- **Before installing/servicing this unit, technicians MUST put on all PPE required for the work being undertaken (Examples; cut resistant gloves/sleeves, butyl gloves, safety glasses, hard hat/bump cap, fall protection, electrical PPE and arc flash clothing). ALWAYS refer to appropriate Safety Data Sheets (SDS) and OSHA guidelines for proper PPE.**
- **When working with or around hazardous chemicals, ALWAYS refer to the appropriate SDS and OSHA/GHS (Global Harmonized System of Classification and Labelling of Chemicals) guidelines for information on allowable personal exposure levels, proper respiratory protection and handling instructions.**
- **If there is a risk of energized electrical contact, arc, or flash, technicians MUST put on all PPE in accordance with OSHA, NFPA 70E, or other country-specific requirements for arc flash protection, PRIOR to servicing the unit. NEVER PERFORM ANY SWITCHING, DISCONNECTING, OR VOLTAGE TESTING WITHOUT PROPER ELECTRICAL PPE AND ARC FLASH CLOTHING. ENSURE ELECTRICAL METERS AND EQUIPMENT ARE PROPERLY RATED FOR INTENDED VOLTAGE.**

⚠ WARNING**Follow EHS Policies!**

Failure to follow instructions below could result in death or serious injury.

- All Trane personnel must follow the company's Environmental, Health and Safety (EHS) policies when performing work such as hot work, electrical, fall protection, lockout/tagout, refrigerant handling, etc. Where local regulations are more stringent than these policies, those regulations supersede these policies.
- Non-Trane personnel should always follow local regulations.

⚠ WARNING**Refrigerant under High Pressure!**

Failure to follow instructions below could result in an explosion which could result in death or serious injury or equipment damage.

System contains refrigerant under high pressure. Recover refrigerant to relieve pressure before opening the system. See unit nameplate for refrigerant type. Do not use non-approved refrigerants, refrigerant substitutes, or refrigerant additives.

Factory Warranty Information

Compliance with the following is required to preserve the factory warranty:

All Unit Installations

Startup MUST be performed by Trane, or an authorized agent of Trane, to VALIDATE this WARRANTY. Contractor must provide a two-week startup notification to Trane (or an agent of Trane specifically authorized to perform startup).

Additional Requirements for Units Requiring Disassembly and Reassembly

When a new chiller is shipped and received from our Trane manufacturing location and, for any reason, it requires disassembly or partial disassembly, and reassembly—which could include but is not limited to the evaporator,

condenser, control panel, compressor/motor, economizer, factory-mounted starter or any other components originally attached to the fully assembled unit—compliance with the following is required to preserve the factory warranty:

- Trane, or an agent of Trane specifically authorized to perform start-up and warranty of Trane® products, will perform or have direct on-site technical supervision of the disassembly and reassembly work.
- The installing contractor must notify Trane—or an agent of Trane specifically authorized to perform startup and warranty of Trane® products—two weeks in advance of the scheduled disassembly work to coordinate the disassembly and reassembly work.
- Start-up must be performed by Trane or an agent of Trane specifically authorized to perform startup and warranty of Trane® products.

Trane, or an agent of Trane specifically authorized to perform start-up and warranty of Trane® products, will provide qualified personnel and standard hand tools to perform the disassembly and reassembly work at a location specified by the contractor. The contractor shall provide the rigging equipment such as chain falls, gantries, cranes, forklifts, etc. necessary for the disassembly and reassembly work and the required qualified personnel to operate the necessary rigging equipment.

Copyright

This document and the information in it are the property of Trane, and may not be used or reproduced in whole or in part without written permission. Trane reserves the right to revise this publication at any time, and to make changes to its content without obligation to notify any person of such revision or change.

Trademarks

All trademarks referenced in this document are the trademarks of their respective owners.

Revision History

- Updated X code information in the cover page.
- Updated Typical unit nameplate figure in Unit Nameplate chapter.



Table of Contents

Unit Nameplate	7	Refrigerant Pressure Relief Valve	
Compressor Nameplate	8	Venting	22
Model Number Descriptions	9	Freeze Protection	24
General Information	11	Installation: Water Piping	26
Unit Description	11	Overview	26
Component Locations	11	Water Treatment	26
Chiller	11	Water Pressure Gauges	26
Adaptive Frequency Drive	12	Valves – Drains and Vents	26
Unit Clearances	13	Strainers	27
Dimensions and Weights	14	Required Flow-Sensing Devices	27
Dimensions	14	Water Flow Detection Controller and	
Unit Specifications—Imperial (I-P)		Sensor	27
Units	14	Evaporator and Condenser Water	
Unit Specifications—International		Piping	29
System (SI) Units	15	Water Piping Connections	30
Pre-installation	16	Waterbox Locations	30
ASHRAE Standard 15 Compliance	16	Reversing Waterboxes	30
Inspection Checklist	16	Grooved Pipe Coupling	31
Loose Parts Inventory	16	Flange-connection Adapters	31
Storage	16	Victaulic Gasket Installation	32
Installation Requirements and Contractor		Screw-Tightening Sequence for Water	
Responsibilities	16	Piping Connections	32
Installation: Mechanical	18	Flanges with 8 or 12 Screws	32
Location Requirements	18	Pressure Testing Waterside Piping	33
Sound Considerations	18	Eddy Current Testing	33
Foundation Requirements	18	Insulation	34
Clearances	18	Unit Insulation Requirements	34
Ventilation	18	Insulation Thickness Requirements	34
Water Drainage	18	Factory-applied Insulation	34
Access Restrictions	18	Electrical Requirements	36
Operating Environment	18	Installation Requirements	36
Adaptive Frequency Drive Enclosure		Electrical Requirements	36
Rating	19	Adaptive Frequency Drive	37
Rigging	19	System Control Circuit Wiring (Field	
Standard Chiller Lift	20	Wiring)	38
Special Lift Requirements	20	Sensor Circuits	39
Unit Isolation	20	Schematic Wiring Drawings	41
Isolation Pads	20	Adaptive Frequency Drive	41
Spring Isolators	21		
Leveling the Unit	21		

Programming.....	41	Stopped to Starting — Heating	
Building Automation Systems	41	Mode.....	55
BACnet Building Automation Control		Running	56
Network	41	Satisfied Setpoint	57
Modbus Automation Control		Normal Shutdown to Stopped or Run	
Network	41	Inhibit	58
LonTalk Building Automation		Immediate Shutdown to Stopped or	
Systems	41	Run Inhibit	59
Installation: Controls	43	AFD Mains Phase Loss	60
Overview	43	Ice Making (Running to Ice Making to	
Symbio™ 800.....	43	Running)	61
AdaptiView™ Display	43	Ice Making (Auto to Ice Making to Ice	
Tracer TU	43	Making Complete).....	62
Integrated Rapid Restart.....	43	Limit Conditions	63
AdaptiView Control Panel.....	45	Control Panel Devices and Unit-Mounted	
Installing the Tracer AdaptiView		Devices	63
Display.....	46	Unit Control Panel.....	63
Adjusting the Tracer® AdaptiView™		User-defined Language Support	63
Display Arm.....	47	Unit Start-up and Shutdown	
Module Installation.....	47	Procedures	64
Air-Fi®.....	47	Unit Start-up.....	64
Wi-Fi	48	Temporary Shut-down and Restart	64
Operating Principles	49	Extended Unit Shut-down	64
General Requirements	49	Seasonal Unit Start-up.....	64
Refrigeration Cycle	49	Maintenance	66
Compressor Motor.....	49	Recommended Maintenance.....	66
Adaptive Frequency Drive	49	Weekly	66
Uninterruptible Power Supply.....	49	Monthly.....	66
Evaporator and Condenser	50	Annual	66
Drive Cooling System	50	Other.....	66
Tracer® AdaptiView™ Display.....	50	Maintenance Procedures	66
Start-up and Shutdown	51	Drive Cooling System.....	66
Sequence of Operation.....	51	Cleaning the Condenser	67
Software Operation Overview		Cleaning the Evaporator	69
Diagram	51	Waterbox Hinges	69
Power Up	52	Adaptive Frequency Drive Periodic	
Power Up to Starting	53	Maintenance and Inspection	69
Stopped to Starting — Cooling		Visual Inspection—Power	
Mode.....	54	Removed	69
		Operational Inspection—Power	
		Applied	70
		Wiring.....	71
		Appendix A: Forms and Check Sheets.....	72



Table of Contents

Unit Start-up/Commissioning	72	Appendix C: Settings	75
Appendix B: Chiller Installation Completion and Request for Trane Service	73	Appendix D: Operator Log	77



Unit Nameplate

The unit nameplate is located on the right side of the control panel. A typical unit nameplate is illustrated in the following figure and contains the following information:

- Unit model and size descriptor
- Unit serial number
- Unit electrical requirements
- Correct operating charge and refrigerant type
- Unit test pressures and maximum operating pressures
- Unit literature
- Drawing numbers for unit wiring diagrams

Serial Number. The unit serial number provides the specific chiller identity. Always provide this serial number when calling for service or during parts identification.

Service Model Number. The service model represents the unit as built for service purposes. It identifies the selections of variable unit features required when ordering replacements parts or requesting service.

Note: Unit-mounted Adaptive Frequency™ Drives (AFDs) are identified by a separate number; refer to “ ”.

Product Description Block. The Agility™ chiller models are defined and built using the Product Definition and Selection (PDS) system. This system describes the product offerings using a product coding block which is made up of feature categories and codes that identify all characteristics of a unit.

Figure 1. Typical unit nameplate

TRANE MADE IN USA

MODEL: HDWA400 DATE OF MFG (DD/MM/YY): 01-02-18
 MODEL NO:
 HDWA400FAAL0DCBMFCBJFABG140W1100A
 SERIAL NO: L17M05538 S.O.NO: MSHDWAL

AFD MODEL: AFDT0173FAAA00E2B1
 AFD PART NO: 453693600007

ELECTRICAL CHARACTERISTICS
 RATED VOLTAGE: 460 VOLTS 3- 60HZ
 NAMEPLATE KW: 105 KW LINE CURRENT: 160 AMPS
 VOLTAGE UTILIZATION RANGE: 414- 506 VAC
 MINIMUM CIRCUIT AMPACITY: 200 AMPS
 MAXIMUM OVERCURRENT PROTECTIVE DEVICE: 350 AMPS
 SHORT CIRCUIT CURRENT RATING: 65000 AMPS

	VOLTS-AC	HZ	PH	RLA
COMPRESSOR MOTOR				173
CONTROL CIRCUIT	115	60	1	3000 VA MAX

REFRIGERANT SYSTEM
 TO BE FIELD CHARGED FACTORY CHARGED
 WITH 800 LBS. OF R-134A WITH LBS. OF R-134A

MAXIMUM REFRIGERANT WORKING PRESSURE
 HI SIDE 300 PSIG LO SIDE 200 PSIG
 FACTORY TEST PRESSURE
 HI SIDE 330 PSIG LO SIDE 260 PSIG

PATENT PENDING

SERVICE LITERATURE
 INSTALLATION/OPERATION/MAINTENANCE GUIDE:
 HDWA-SVX001A-EN

FOR INSTALLATION REQUIREMENTS, USE ELECTRICAL CHARACTERISTICS NOT PRODUCT DESCRIPTION.

PRODUCT DESCRIPTION:

NMRA 173	IMP1 200	IMP2 174	PTON 200
MODL HDWA	DSEQ AA	APTY STD	TRPM 4500
LQDD NO	LQDP NO	NTON 400	TYPE SNGL
IHRZ 60	VOLT 460	CPKW 442	IVLT 460
DSOP YES	EVSZ 040A	ETSP NONE	FRAM T1
EVTM TMCU	EVTC 280	EVTH 25	EVBS B
EVWC STD	EVWP 2	EVWT NMAR	EVPR 150
EVCO FLNG	EFLD WATE	EVFP TDFS	EVWA RERE
TSTY STD	CTSP NONE	CDBS B	CDSZ 040A
CDTC 283	CDTH 28	CDPR 150	CDTM TECU
CDWP 2	CDWT NMAR	CDWA LELE	CDWC STD
CFLD WATE	CDFP TDFS	EXEV 30.6	CDCO FLNG
GNSL YES	AH13 COMP	AH16 COMP	AGLT UL
FTST YES	TL0C FACT	TEST NONE	ARCL CERT
TPUL AHRI	ASTT NO	ASKT NONE	TTOL NA
OPMM KWTN	INSL STD	OPST YES	DEMO YES
EXOP YES	TRMM BCNT	CWR YES	GBAS YES
SPKG DOM	WPSR WFC	REFG YES	TRIC TRIP
RLDV SPLD	THRM TME	STRM AFDT	CRFG R134
SRRL 440	RCTP YES		SRTY UAFD

ASHRAE 90.1 - 2013 AND 2016 COMPLIANT





Unit Nameplate

Compressor Nameplate

The compressor assembly has a separate model number which is required to identify internal and external compressor parts. The model number begins with "HDMA" and the nameplate is located on the interstage pipe; refer to " , .

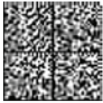
Figure 2. Compressor nameplate

 HDM COMPRESSOR	SERIAL NUMBER	<input type="text"/>	
	MODEL NUMBER	<input type="text"/>	
	SALES ORDER NUMBER	<input type="text"/>	
ELECTRICAL CHARACTERISTICS TO DRIVE			
DRIVE INPUT	DRIVE INPUT		
VOLTAGE	FREQUENCY (HZ)		
<input type="text" value="480-460"/>	<input type="text" value="50 OR 60"/>		
NOTICE: VARIABLE SPEED COMPRESSORS ELECTRICAL SUPPLY VIA TRANE SUPPLIED DRIVE ONLY.			
REFRIGERANT			
<input type="text" value="R-134a OR R-513A"/>			
THERMALLY PROTECTED SYSTEM			
			
ASSEMBLED IN USA			
			

Note: Do NOT cover compressor nameplate with wrap or insulation (leave a window).



Model Number Descriptions

Digit 1, 2 — Unit Function

HD = Agility™ Centrifugal Water-cooled Chiller

Digit 3 — Drive

W = Direct Drive

Digit 4 — Development Sequence

A

Digit 5, 6, 7 — Nominal Compressor Tonnage

200 = 200 nominal tons

300 = 300 nominal tons

400 = 400 Nominal Tons

SSS = Special

Digit 8 — Incoming Line Voltage/Unit Drive Voltage

B = 208V Incoming Line/460V-60Hz—3Ph

D = 380V Incoming Line/400V-60Hz—3Ph

F = 460V Incoming Line/400V-60Hz—3Ph

G = 480V Incoming Line/400V-60Hz—3Ph

H = 575V Incoming Line/400V-60Hz—3Ph

J = 600V Incoming Line/400V-60Hz—3Ph

R = 380V Incoming Line/400V-50Hz—3Ph

S = Special

T = 400V Incoming Line/400V-50Hz—3Ph

U = 415V Incoming Line/400V-50Hz—3Ph

Digit 9 — Unit Type

A = Cooling Condenser

S = Special

Digit 10, 11 — Design Sequence

AA = Original Design

Digit 12 — Manufacturing Location

L = La Crosse, Wisconsin

Digit 13 — Hot Gas Bypass

0 = Without HGB

S = Special

Digit 14 — Control Enclosure

C = Standard Control Enclosure

D = Standard Control Enclosure with Tracer® SC

K = Standard Control Enclosure with Wi-Fi

L = Standard Control Enclosure with Air-Fi

M = Standard Control Enclosure with Wi-Fi and Air-Fi

S = Special

Digit 15 — Evaporator Shell Size

A = 020A Evaporator Shell

C = 040A Evaporator Shell

S = Special

Digit 16 — Evaporator Tube Bundle

A = Evaporator Tube Bundle A

B = Evaporator Tube Bundle B

C = Evaporator Tube Bundle C

D = Evaporator Tube Bundle D

E = Evaporator Tube Bundle E

S = Special

Digit 17 — Evaporator Tubes

C = 0.025 Wall Thickness—0.75 Diameter Internally Enhanced Copper Evaporator Tube

M = 0.025 Wall Thickness—0.75 Diameter High Performance Internal Surface Evaporator Tube

S = Special

Digit 18 — Evaporator Waterbox

B = 150 psi Marine, 2-Pass

D = 300 psi Marine, 2-Pass Standard

F = 150 psi Non-marine, 2-Pass Standard

H = 300 psi Non-marine, 2-Pass Standard

S = Special

Digit 19 — Condenser Shell Size

A = 020A Condenser Shell

C = 040A Condenser Shell

S = Special

Digit 20 — Condenser Tube Bundle

A = Condenser Tube Bundle A

B = Condenser Tube Bundle B

C = Condenser Tube Bundle C

S = Special

Digit 21 — Condenser Tubes

C = 0.025 Condenser Tube Wall—0.75 Internal Enhanced Copper Tube

J = 0.028 Condenser Tube Wall—0.75 Internal Enhanced Copper Tube

S = Special

Digit 22 — Condenser Waterbox

B = 150 psi Marine, 2 Pass

D = 300 psi Marine, 2-Pass Standard

F = 150 psi Non-marine, 2-Pass Standard

H = 300 psi Non-marine, 2-Pass Standard

S = Special

Digit 23 — Evaporator Expansion Valve

A = 400

B = 200

S = Special

Digit 24 — Unit Option

B = Insulation Package and Spring Loaded Pressure Relief Valve

D = Spring Loaded Pressure Relief Valve Only

Digit 25 — Control: Generic Building Automation System (BAS)

0 = None

G = Generic BAS

Digit 26 — Control: Extended Operation

0 = None

1 = Extended Operation

Digit 27 — Tracer® Communication Interface

0 = None

2 = Tracer® Comm 5

3 = Tracer® MODBUS®

4 = Tracer® BACnet®

5 = LON Interface Module

Digit 28 — Special Options

0 = None

S = Special Option

Digit 29 — Control: Water Flow Control

0 = None

W = Water Flow Control

Digit 30 — Control: Chilled Water Reset

0 = None

1 = Chilled Water Reset

Digit 31 — Control: Operating Status

0 = None

1 = Operating Status

Digit 32 — Industrial Chiller Package (INDP)

0 = Without INDP



Model Number Descriptions

Digit 33 — Control Power Transformer (CPTR)

0 = Without CPTR
S = Special

Digit 34 — Thermal Dispersion Water Flow Proving

0 = None, Customer to Provide Device for Condenser and Evaporator
A = Thermal Dispersion Water Flow Proving Selected for Condenser and Evaporator

HDMA Centrifugal Compressor Description

The compressor assembly has a separate model number which is required to identify internal and external compressor parts. The model number begins with HDMA and the nameplate is located on the foot of the volute.

Digit 1 — Higher-speed Centrifugal

Digit 2 — Direct Drive

Digit 3 — Medium Pressure

Digit 4 — Development Sequence

Digit 5, 6, 7 — Nominal Total Compressor Tonnage

Digit 8 — Compressor AFD Input Design Voltage

Digit 9 — Motor Type

Digit 10, 11 — Design Sequence

Digit 12, 13, 14 — First Stage Impeller Designation

Digit 15, 16, 17 — Second Stage Impeller Designation

Digit 18 — Bearing Type

Digit 19 — Discharge Port Orientation

Digit 20 — Motor Cooling

Adaptive Frequency Drive Description

The Adaptive Frequency™ Drive (AFD) has a separate model number which is required to identify the drive and its components. The model number begins with AFDT or VFDC.

Digit 1, 2, 3 — Adaptive Frequency™ Drive

AFD = 200 NTON (LC Filter)
VFD = 300/400 NTON (No LC Filter)

Digit 4 — Development Sequence

T = Unit-mounted, Air-/Liquid-cooled Communicating with Symbio™ Controls, 200NTON (LC Filter)
C = Unit-mounted, Air-/Liquid-cooled Communicating with Symbio™ Controls, 300/400 NTON (No LC Filter)

Digit 5, 6, 7, 8 — Starter Size

Use Rated Load Amps (RLA) Value

Digit 9 — Incoming Line Voltage/Unit Drive Voltage

B = 208V Incoming Line/460V-60Hz-3Ph
D = 380V incoming Line/400V-60Hz-Ph
F = 460V Incoming Line/400V-60Hz-3Ph
G = 480V Incoming Line/400V-60Hz-3Ph
H = 575V Incoming Line/400V-60Hz-3Ph
J = 600V Incoming Line/400V-60Hz-3Ph
R = 380V incoming Line/400V-50Hz-3Ph
S = Special
T = 400V Incoming Line/400V-50Hz-Ph
U = 415V Incoming Line/400V-50Hz-3Ph

Digit 10, 11 — Design Sequence

AA = Original Design of Symbio 800™ Controls with TR200 Drive
AB = UPS Change and Addition of the 208V:460V, 60Hz Option
AC = Symbio 800 with Circuit Breaker Power Metering Option
AD = XT Circuit Breaker and UL Update

Digit 12 — Starter Type

A = Unit-mounted

Digit 13 — Agency Listing

0 = UL- and CUL-Listed (Standard on All Units)

Digit 14 — Special Options

0 = None
S = Special Options (See Sales Order)

Digit 15 — VFD Frame Size (SRRL)

D = 362/363
E = 440/439
F = 532
G = 675
H = 243/238

Digit 16 — Connection Type Short Circuit Current Rating (SCCR)

2 = Standard Circuit Breaker
S = Special

Digit 17 — Control Power Option

B = Control Power Transformer 3kVA

Digit 18 — Panel Option

0 = None
1 = Input Harmonic Filter
2 = 575V/60 Hz Autotransformer
3 = 208V/60 Hz Autotransformer
S = Special Option

Digit 19 — Control Meters

0 = None
1 = Circuit Breaker Communicating Power Meter
S = Special Option



General Information

Unit Description

Agility™ chillers are centrifugal, water-cooled liquid chillers designed for indoor installation. Each unit is a completely assembled, hermetic package that is factory-piped, wired, leak-tested, dehydrated, charged, and tested for proper control operation before shipment. The following figures show typical Agility™ chillers and their components. Water

inlet and outlet openings are covered before shipment. The unit ships charged with refrigerant.

Component Locations

Chiller

Figure 3. Typical Agility chiller component location (front view)

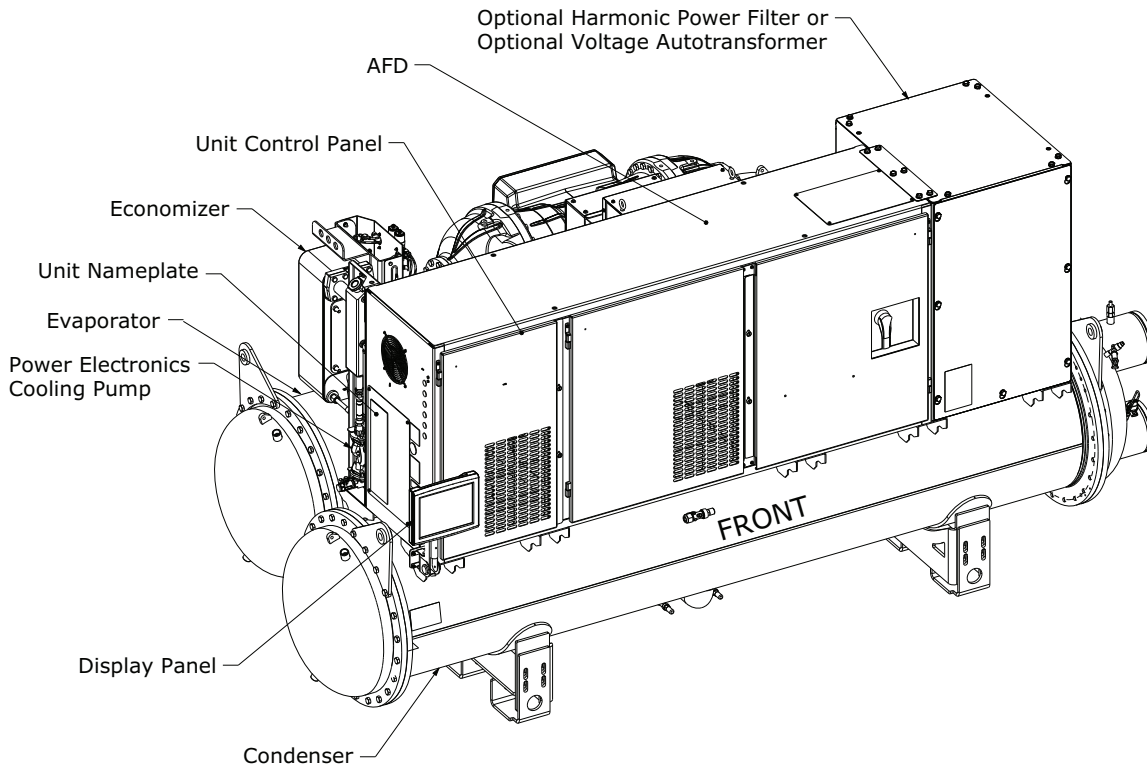
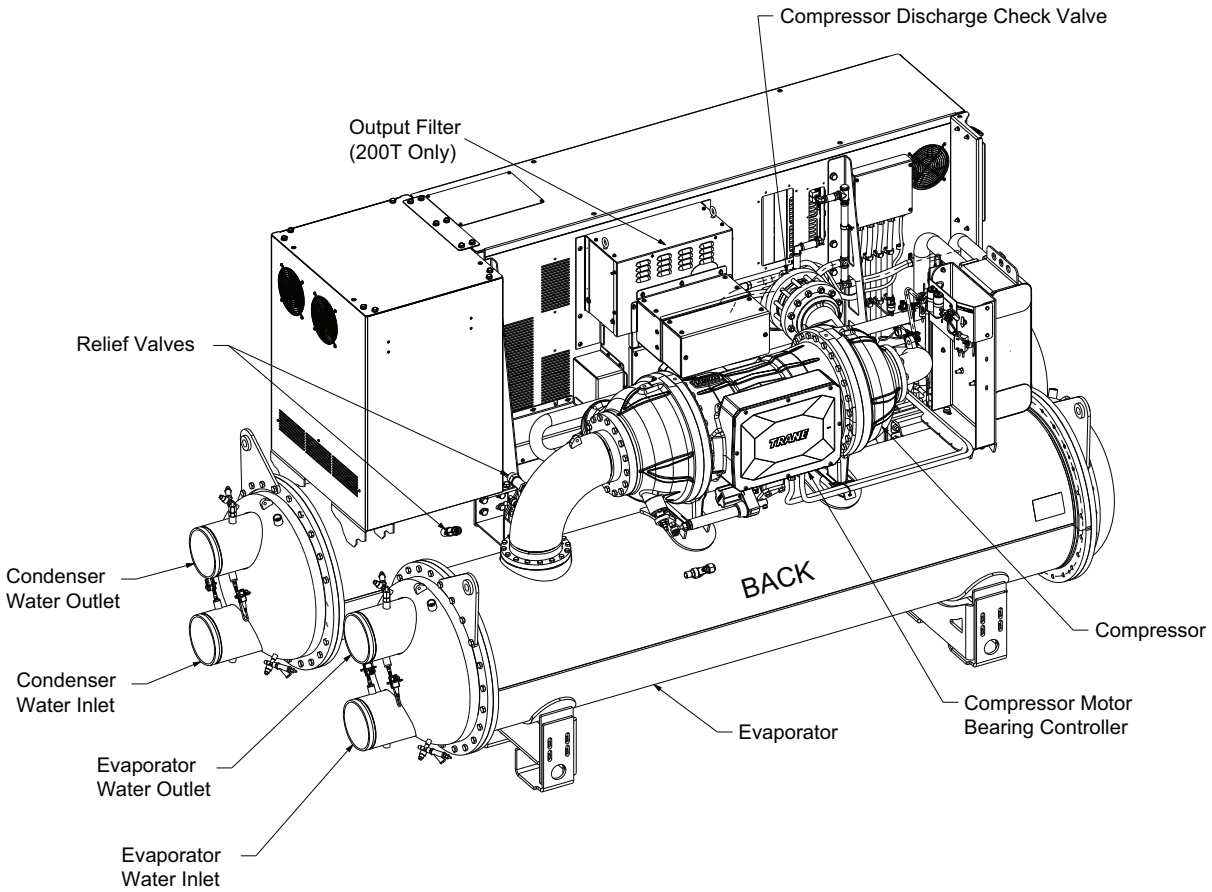

Figure 4. Typical Agility chiller component location (back view)



Adaptive Frequency Drive

Figure 5. Assembly transformer options

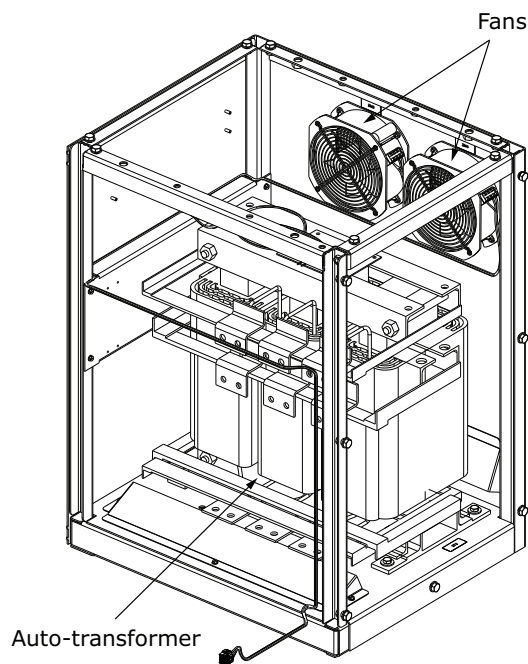
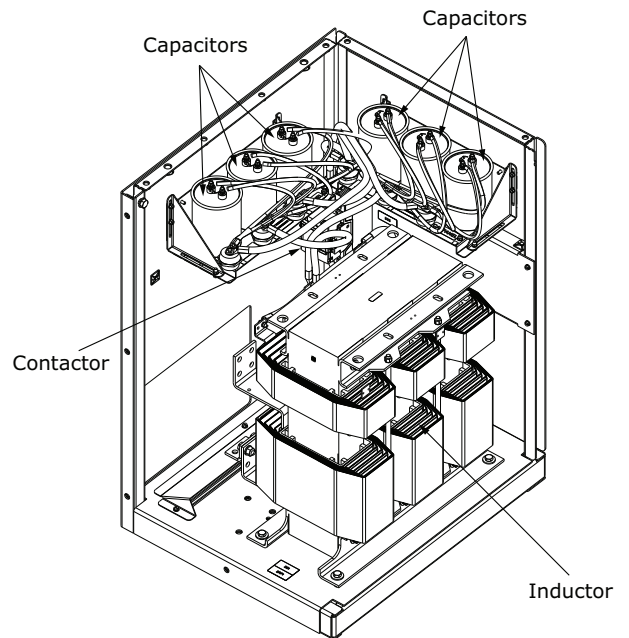
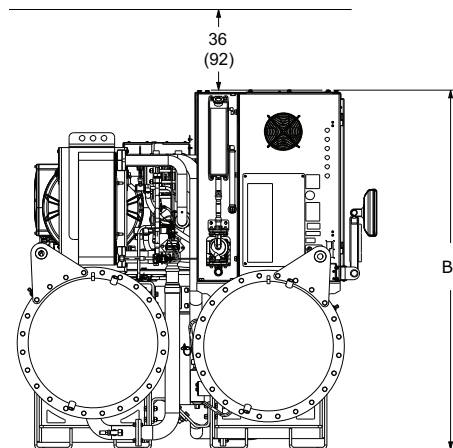
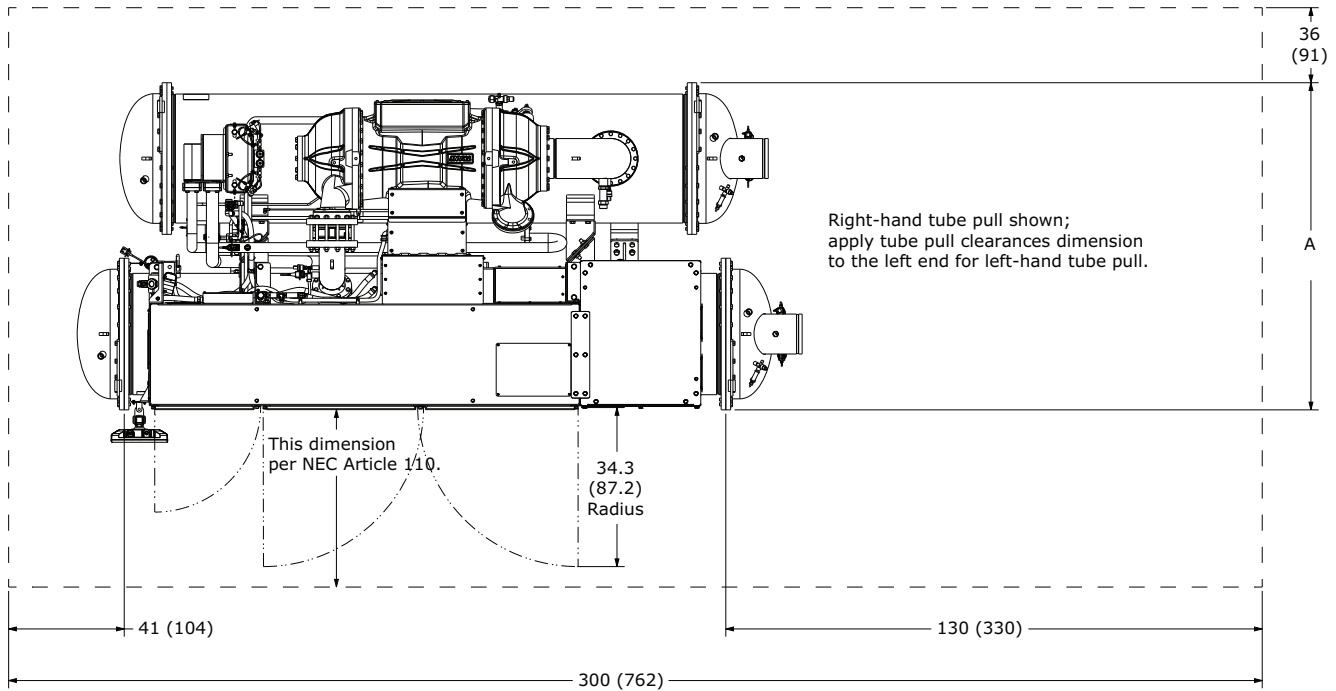

Figure 6. Assembly harmonic filter options



Unit Clearances

Figure 7. Clearance requirements, in. (cm)



	Dim. A inches (cm)	Dim. B inches (cm)
020A Shells	67.5 (171)	72-3/16 (183)
040A Shells	70.7 (179)	77-11/16 (197)

Note that hinges increase the overall size of Dim A by 6.6 inches (16.76 cm).



General Information

Dimensions and Weights

Dimensions

Refer to unit submittals for specific chiller dimensions and water connection locations.

Unit Specifications—Imperial (I-P) Units

Weights (lb)

Important: The weight information provided here should be used for general information only. For specific weights for your chiller, refer to your submittal package.

Table 1. Agility chiller weights (lb)

Shell		Shipping Weight		Operating Weight
		With Refrigerant	Without Refrigerant	
020	Minimum	10100	9575	14087
	Maximum	12302	11777	16775
040	Minimum	12706	11906	14134
	Maximum	15058	14258	16830

Notes:

1. All weights ±5 percent.
2. Shipping weights include standard 150 psig waterboxes.
3. Operating weights include refrigerant, glycol, and water charges.
4. Optional waterbox hinges each weigh 44 lb (19.94 kg).

Center of Gravity (in.)

Table 2. Agility chiller center of gravity (in.)

	Shipping			Operating		
	X	Y	Z	X	Y	Z
Minimum	29.2	31.2	39.7	29.6	29.3	39.8
Maximum	31.7	32.5	46.9	32.1	30.8	46.4

Notes:

1. All weights ±5 percent.
2. Shipping weights include standard waterboxes.
3. Operating weights include refrigerant, glycol, and water charges.

Figure 8. Zero point location for center of gravity data

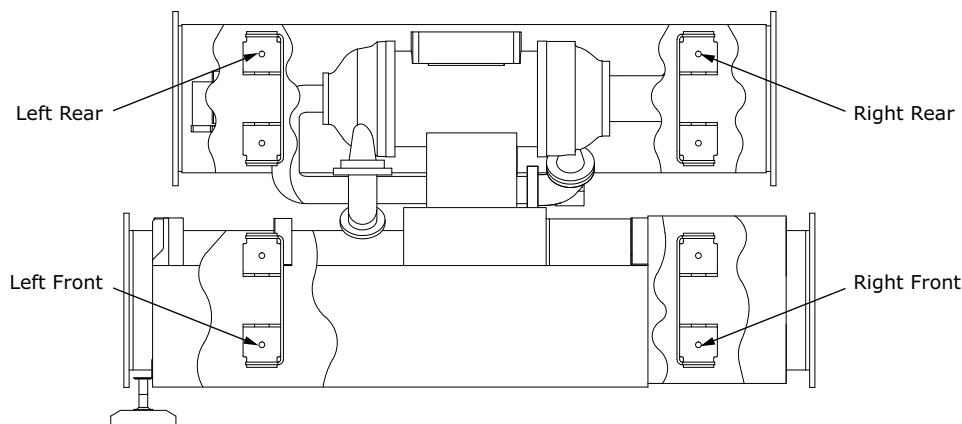

Right Front Mounting Hole
The bottom of this hole is the (0,0,0) point for center of gravity dimensions.

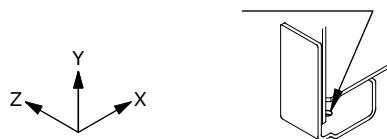

Unit Specifications—International System (SI) Units

Weights (kg)

Important: The weight information provided here should be used for general information only. For specific weights for your chiller, refer to your submittal package.

Table 3. Agility chiller weights (kg)

Shell		Shipping Weight		Operating Weight
		With Refrigerant	Without Refrigerant	
020	Minimum	4591	4352	4980
	Maximum	5592	5353	5836
040	Minimum	5775	5412	6425
	Maximum	6845	6481	7650

Notes:

1. All weights ± 5 percent.
2. Shipping weights include standard waterboxes.
3. Operating weights include refrigerant, glycol, and water charges.
4. Optional waterbox hinges: each waterbox hinge weights 44 lb (19.94 kg).

Center of Gravity (mm)

Table 4. Agility chiller center of gravity (mm)

	Shipping			Operating		
	X	Y	Z	X	Y	Z
Minimum	742	793	1007	752	743	1011
Maximum	804	826	1190	816	781	1178

Notes:

1. All weights ± 5 percent.
2. Shipping weights include standard waterboxes.
3. Operating weights include refrigerant, glycol, and water charges.



Pre-installation

ASHRAE Standard 15 Compliance

Trane recommends that indoor Agility™ chiller installations fully meet or exceed the guidelines of the current version of ASHRAE® Standard 15, in addition to any applicable national, state, or local requirements. This typically includes:

- A refrigerant monitor or detector that is capable of monitoring and alarming within the acceptable exposure level of the refrigerant, and that can actuate mechanical ventilation.
- Audible and visual alarms, activated by the refrigerant monitor, inside the equipment room and outside of every entrance.
- The equipment room should be properly vented to the outdoors, using mechanical ventilation that can be activated by the refrigerant monitor.
- If required by local or other codes, a self-contained breathing apparatus should be available in close proximity to the equipment room.

Refer to the latest copy of ASHRAE Standard 15 for specific guidelines. Trane assumes no responsibility for any economic, health, or environmental issues that may result from an equipment room's design or function.

Inspection Checklist

To protect against loss due to damage incurred in transit, complete the following checklist upon receipt of the unit.

- Inspect the individual pieces of the shipment before accepting the unit. Check for obvious damage to the unit or packing material.
- Inspect the unit for concealed damage as soon as possible after delivery and before it is stored. Concealed damage must be reported within 10 days after receipt.
- If concealed damage is discovered, stop unpacking the shipment. Do not remove damaged material from the receiving location. Take photos of the damage, if possible. The owner must provide reasonable evidence that the damage did not occur after delivery.
- Notify the carrier's terminal of the damage immediately, by phone and by mail. Request an immediate, joint inspection of the damage with the carrier and the consignee.
- Notify the Trane sales representative and arrange for repair. Do not repair the unit, however, until damage is inspected by the transportation representative.
- Verify all ship-with items received, including the optional communication devices such as .Air-Fi®, Wi-Fi, or LTE modem

Loose Parts Inventory

Check all items against the shipping list. Display, display arm and mounting, water vessel drain plugs, isolation pads, Air-Fi®, Wi-Fi, LTE modem, and other optional components are shipped loose in the parts box. If the chiller is to be disassembled for installation, ensure that the disassembly kit is included with the chiller. Electrical diagrams and service literature are located inside the Adaptive Frequency™ Drive (AFD) panel.

Storage

Note: *If the chiller is stored outdoors for any amount of time, do NOT remove ANY shipping coverings. Protect the chiller from the elements and protect against freezing, especially if any shipping materials have been removed.*

If the chiller is to be stored more than one month prior to installation, observe the following precautions:

- Do NOT store the chiller in areas in which the temperature exceeds 122°F (50.0°C) or the refrigerant will relieve.
- Do NOT remove the protective coverings from the electrical panel.
- Store the chiller in a dry, secure area.
- Upon receipt and every three months thereafter, attach a gauge and manually check the pressure in the refrigerant circuit. Call a qualified service organization and the appropriate Trane sales office if:
 - for R-134a, if the refrigerant pressure is below 71 psig at 70°F (489.5 kPaG at 21.1°C) or 46 psig at 50°F (317.2 kPaG at 10.0°C).
 - for R-513A, if the refrigerant pressure is below 77 psig (530.9 kPaG at 21.1°C) at 70°F or 50 psig at 50°F (344.7 kPaG at 10.0°C).

Note: *Pressure will be approximately 5 psig (34.5 kPaG) if shipped with the optional nitrogen charge*

Installation Requirements and Contractor Responsibilities

A list of the contractor responsibilities typically associated with the unit installation process is provided in the following table.

<p>⚠ WARNING</p> <p>Combustible Material!</p> <p>Failure to follow instructions below could result in death, serious injury, or equipment damage. Shrink-wrap is a combustible material. Avoid open flames and hot sparks.</p>
--

Note: The chiller should remain within its protective shrink-wrap covering during storage.

Type of Requirement	Trane Supplied Trane Installed	Trane Supplied Field Installed	Field Supplied Field Installed
Foundation			<ul style="list-style-type: none"> Meet foundation requirements
Rigging			<ul style="list-style-type: none"> Safety chains Rigging shackles Lifting beam
Disassembly/Reassembly (as required)	<ul style="list-style-type: none"> Trane will perform or have direct on-site supervision of the disassembly and reassembly work (contact your local Trane office for pricing) 		
Isolation		<ul style="list-style-type: none"> Isolation pads 	<ul style="list-style-type: none"> Isolation pads Optional spring isolators, when required, are installed by others; do NOT overload springs and do NOT install isolation springs if they block serviceable parts such as service valves, etc.
Electrical	<ul style="list-style-type: none"> Circuit breakers Unit-mounted Adaptive Frequency™ Drive (AFD) Harmonic filter (optional) Autotransformer (optional) 	<ul style="list-style-type: none"> Temperature sensor (optional outdoor air) Flow switches (may be field supplied) Tracer® AdaptiView™ display and mounting arm Air-Fi® Wireless Communication Wi-Fi Wireless Communication 	<ul style="list-style-type: none"> Electrical connections to unit-mounted AFD Wiring sizes per submittal and National Electric Code (NEC) Ground connection(s) BAS wiring (optional) Inter-processor communication (IPC) wiring Control voltage wiring High condenser pressure interlock wiring Chilled water pump contactor and wiring Condenser water pump contactor and wiring Option relays and wiring
Water piping		<ul style="list-style-type: none"> Flow switches (may be field supplied) Condenser water regulating valve controller (optional; may be field-supplied) 	<ul style="list-style-type: none"> Thermometers Water flow pressure gauges Isolation and balancing valves in water piping Vents and drain valves Pressure relief valves (for waterboxes as required)
Pressure Relief	<ul style="list-style-type: none"> Relief valves 		
Insulation	<ul style="list-style-type: none"> Insulation (optional) 		<ul style="list-style-type: none"> Insulation
"Appendix B: Chiller Installation Completion and Request for Trane Service," p. 73 (HDWA-ADF003*-EN; refer to ".")			<ul style="list-style-type: none"> To be completed by installing contractor prior to contacting Trane for start-up
Chiller start-up commissioning (a)	<ul style="list-style-type: none"> Trane, or an agent of Trane specifically authorized to perform start-up of Trane® products 		
Post-commissioning transport of empty refrigerant containers for return or recycling			<ul style="list-style-type: none"> Move empty refrigerant containers to an easily accessible point of loading

(a) Start-up must be performed by Trane or an agent of Trane specifically authorized to perform start-up and warranty of Trane® products. Contractor shall provide Trane (or an agent of Trane specifically authorized to perform start-up) with notice of the scheduled start-up at least two weeks prior to the scheduled start-up.



Installation: Mechanical

Location Requirements

Sound Considerations

- Install rubber vibration isolators in all water piping.
- Isolate all pipe hangers and be sure they are not supported by main structure beams that could introduce vibration into occupied spaces.
- Make sure that the piping does not put additional stress on the unit.

Note: Do not use metal braided type eliminators on the water piping. Metal braided eliminators are not effective at the frequencies at which the unit will operate.

- Use flexible electrical conduit.
- Seal all wall penetrations.

Note: Consult an acoustical engineer for critical applications.

Foundation Requirements

Chiller mounting surface must be:

- Rigid non-warping mounting pads or a concrete foundation, and
- Able to support the chiller at its full operating weight (including completed piping and full operating charges of refrigerant and water).

For proper unit operation, the chiller must be level within 1/4 in. (6.35 mm) over its length and width when set into place on the mounting surface. Refer to “Leveling the Unit,” p. 21 for more information. For minimum and maximum chiller weights/dimensions in pounds/inches and kilograms/millimeters, refer to “Weights (lb),” p. 14 and “Weights (kg),” p. 15, respectively.

Note: For specific weight information, refer to the unit submittal package.

Important: Trane will not assume responsibility for equipment problems resulting from an improperly designed or constructed foundation.

Clearances

Provide enough space around the unit to allow the installation and maintenance personnel unrestricted access to all service points. Refer to submittal drawings for the unit dimensions.

Refer to “Unit Clearances,” p. 13 for minimum clearances required for service. In all cases, local codes will take precedence over these recommendations.

Ventilation

The unit produces heat even though the compressor is cooled by the refrigerant. Make provisions to remove heat

generated by unit operation from the equipment room. Ventilation must be adequate to maintain an ambient temperature lower than 104°F (40°C).

Vent the evaporator, condenser, and compressor pressure relief valves in accordance with all local and national codes. Refer to “Refrigerant Pressure Relief Valve Venting,” p. 22.

Make provisions in the equipment room to keep the chiller from being exposed to freezing temperatures (32°F [0°C]).

Water Drainage

Locate the unit near a large capacity drain for water vessel drain-down during shutdown or repair. Condensers and evaporators are provided with drain connections. Refer to “,”. All local and national codes apply.

Access Restrictions

Door clearances are provided in “Unit Clearances,” p. 13. See unit submittals for specific “per unit” dimensional information.

Operating Environment

Important:

- The standard chiller is designed for **INDOOR USE ONLY** and as such has NEMA Type 1 enclosures.
- The warranty requires an equipment room/chiller environment surrounding the NEMA 1 chiller to be maintained in the temperature range of 34°F to 104°F (1.1°C to 40°C) AND at less than 95% relative humidity (non-condensing conditions). If your equipment room/chiller environment does not meet these conditions, contact your local Trane Service Agency immediately.
- Chiller required to be installed in a secure location with restricted access.
- This appliance is not intended for use by persons (including children) with reduced physical, sensory, or mental capabilities, or lack of experience and knowledge unless they have been given supervision or instruction concerning use of the appliance by a person responsible for their safety.
- Children are required to be supervised to ensure that they do not play with the appliance.

NOTICE

Equipment Damage!

Failure to protect the unit from freezing could result in equipment damage.

If fluid has been added to the piping, the unit must be protected from freezing. Freeze damage from an unheated equipment room is not the Trane company's responsibility. These are indoor units.

NOTICE

AFD Component Damage!

Operating unit at ambient temperatures below 34°F (1.1°C) or in excess of 104°F (40°C), or in excess of 95% relative humidity (non-condensing conditions), could result in AFD component damage due to the panel's inability to dissipate heat adequately.

If any of these adverse operating conditions are present, take necessary action to improve the equipment room environment.

To ensure that electrical components operate properly, do NOT locate the chiller in an area exposed to dust, dirt, corrosive fumes, or excessive heat and humidity. The ambient temperature range for chiller operation is 34°F to 104°F (1.1°C to 40°C).

Adaptive Frequency Drive Enclosure Rating

The Adaptive Frequency™ Drive (AFD) cabinet has a NEMA 1 enclosure rating:

NEMA 1: Vented. Intended for general-purpose indoor applications.

Environmental Conditions

Important: Location of the Adaptive Frequency™ Drive (AFD) is important if proper performance and normal operating life is to be expected. Therefore, unless designed for special environments, the controller should be installed in an area where the following conditions exist

- Verify that NEMA1 enclosure drives can be kept clean and dry.
- The area chosen should allow the space required for proper air flow. Adequate clearance for air circulation around the enclosure is a 6 in. (16 cm) minimum clearance required wherever vents are located in the cabinet.
- Be sure that the NEMA1 enclosure is installed away from oil, coolants, or other airborne contaminants.
- Do NOT install the drive above 3300 ft (1005.8 m) without derating output power. For every 300 ft (91.4 m) above 3300 ft (1005.8 m), derate the output current 1 percent.
- Line frequency is 50 or 60Hz.

- Maximum elevation at which drive can operation is 9842.5 ft (3000 m).
- Non-corrosive location.
- Verify that the drive location will meet the environmental conditions specified in the following table.

Table 5. Environmental conditions

Condition	Specification
Ambient Temperature (outside NEMA 1 enclosure)	32°F to 104°F (0°C to 40°C)
Storage Temperature (ambient)	-20°F to 122°F (-28.9°C to 50.0°C)
Humidity	5% to 95% (non-condensing)

Rigging

Lifting is the recommended method for moving chillers. Suggested lifting arrangements for standard units are described in “ ”.

Note: The lifting beam used for HDWA Agility™ chillers must be at least 12.5 ft (3.8 m) long.

Important: If unit must be disassembled for installation, refer to Installation Instructions: Agility Chiller Disassembly/Reassembly Units (HDWA-SVN001*-EN) for instructions, including weights and rigging instruction for components.

Agility™ chillers should be moved ONLY by lifting at designated lift points. Refer to the following instructions in this manual for typical rigging arrangements.

⚠ WARNING

Heavy Object!

Failure to follow instructions below could result in unit dropping which could result in death or serious injury, and equipment or property-only damage.

Ensure that all the lifting equipment used is properly rated for the weight of the unit being lifted. Each of the cables (chains or slings), hooks, and shackles used to lift the unit must be capable of supporting the entire weight of the unit. Lifting cables (chains or slings) may not be of the same length. Adjust as necessary for even unit lift.

⚠ WARNING

Improper Unit Lift!

Failure to properly lift unit in a LEVEL position could result in unit dropping and possibly crushing operator/technician which could result in death or serious injury, and equipment or property-only damage.

Test lift unit approximately 24 inches (61 cm) to verify proper center of gravity lift point. To avoid dropping of unit, reposition lifting point if unit is not level.

NOTICE

Wiring Damage!

Damage to unit wiring could result in equipment failure.

Care must be taken during rigging, assembly and disassembly to avoid damaging unit wiring.

Standard Chiller Lift

1. Insert rigging shackles at the points indicated in the following figure. A 1.25 in. (31.8 mm) diameter lifting hole is provided at each of these points.
2. Attach the lifting chains or cables.
3. After the lifting cables are in place, attach a safety chain or cable between the first-stage of the compressor and the lifting beam.

Important: *There should NOT be tension on this safety cable; the cable is used only to prevent the unit from rolling during the lift.*

4. Position isolator pads beneath the chiller feet (refer to “Unit Isolation,” p. 20 for instructions).
5. Once the isolators are in place, lower the chiller—working from end to end—in small increments to maintain stability.
6. When lift is complete, detach the rigging shackles and safety chain.

Figure 9. Typical rigging arrangements

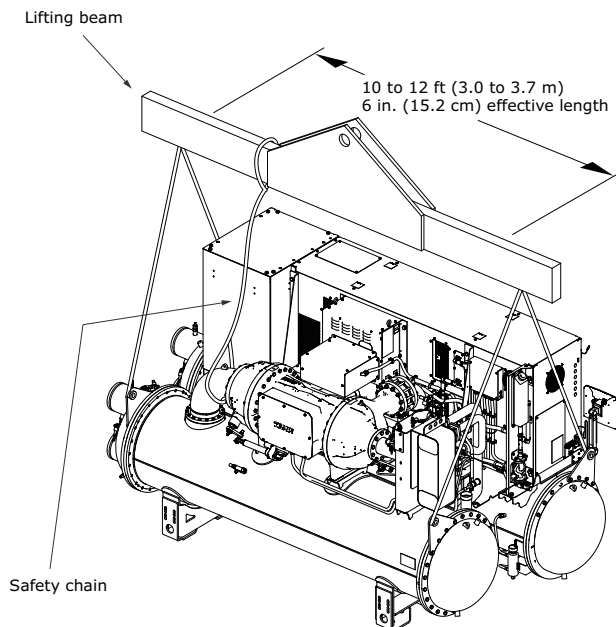

Special Lift Requirements

NOTICE

Equipment Damage!

Moving the chiller using a fork lift could result in equipment or property-only damage.

Do not use a fork lift to move the chiller!

If the chiller cannot be moved using a standard chiller lift, consider the following:

- When job site conditions require rigging of the chiller at an angle greater than 45° from horizontal (end-to-end), the unit may require removal of the compressor. Contact Trane or an agent of Trane specifically authorized to perform start-up and warranty of Trane® products regarding the disassembly and reassembly work. For more information, refer to “Factory Warranty Information,” p. 3.
- **Note:** *Disassembly and reassembly work includes removing the compressor from the unit. Contact Trane or an agent of Trane specifically authorized to perform start-up and warranty of Trane® products for specific rigging instructions. Do NOT attempt to rotate the chiller onto its side.*
- When lifting the chiller is either impractical or undesirable, machinery dollies should be placed under the supports; then push or pull the unit across a smooth surface. Should the chiller be on blocks, it is not necessary to remove the blocks from the chiller before moving it into place.
- Use care on uneven surfaces. Piping in the center of the unit is within 1/2 in. (12.7 mm) of the ground.

Unit Isolation

To minimize sound and vibration transmission through the building structure and to ensure proper weight distribution over the mounting surface, Trane recommends installing isolation padding under the chiller feet. For seismic installations, refer to the specific installation details provided by the foundation designer.

Note: *Isolation pads are provided with each chiller.*

Specific isolator loading data is provided in the unit submittal package. If necessary, contact your local Trane sales office for further information.

Important: *When determining placement of isolation pads, remember that the control panel side of the unit is always designated as the front side of the unit.*

Isolation Pads

When isolation pads are used, place them under each of the eight individual mounting points. The pads may be cut to suit the application, but should cover the entire face of the support.

Spring Isolators

Spring isolators are sometimes considered for chiller installations where vibration transmission is of concern. Spring isolators are typically not needed for Agility chillers due to low vibration characteristics, but can be applied if necessary.

Use the following table to select the appropriate VMC isolator for each of the four isolator loads. For each isolator load, select the spring isolator from the table below that exceeds the isolator load.

Table 6. Spring isolator specifications

Model	Max Load (lb)	Deflection (in)	Spring Color Code
C7T-1D-2380	2380	1.13	RED
C7T-1D-3570	3570	1.02	BLACK
C7T-1D-4725	4725	1.32	DK PURPLE
C7T-1D-6300	6300	1.02	DK GREEN
C7T-1D-8400	8400	0.90	GRAY
C7T-1D-9520	9520	0.77	WHITE
C7T-1D-10500	10500	0.70	GOLD

Example:

- Left rear isolator load is 5,311 lb.
- Select isolator C7T-1D-6300 (dark green) with a maximum load of 6300 lb, the first that is higher than the isolator load.

To prevent full deflection of the isolator, it is recommended to select an isolator with maximum load 15 - 20% greater than the isolator load weights listed in the chiller submittal drawings.

The spring isolators fit in the open space (pocket) in each of the Agility chiller legs. Installing springs in the pocket will reduce the height of the installation. The chiller has four foot pockets, one in each corner, where a spring isolator will be placed.

Figure 10. Spring isolator mounting locations

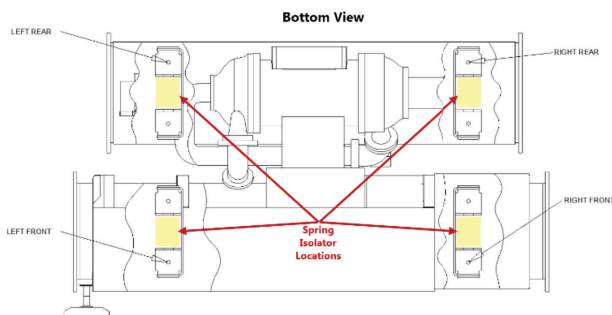

Foot pocket size information is shown in the following table and figure.

Table 7. Spring isolator foot pocket size

Shell Size	Width (in)	Length (in)	Height (in)
020	8.5	7	4.7
040	9	7	4.7

Figure 11. Spring isolator foot pocket

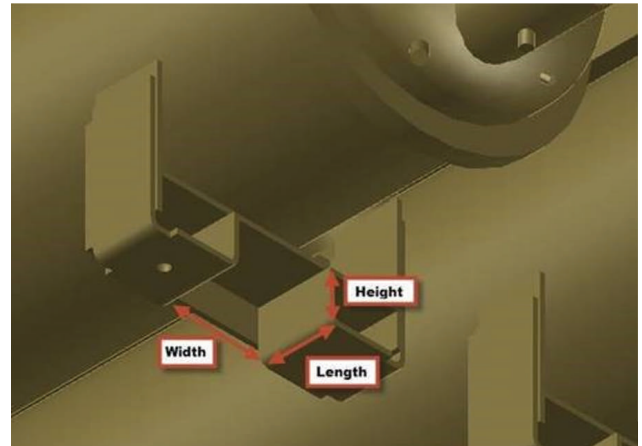

Order isolators through VMC. Isolators are shipped fully assembled and are to be spaced and arranged in accordance with installation drawings from VMC.

Leveling the Unit

Note: The chiller **MUST** be set level within 1/4 in. (6.35 mm) over its length and width.

1. Use a water level to align the tube sheet tooling holes or bottom edge of the tube sheet axially along both the condenser and evaporator; refer to the following figures.
2. Use a water level to align the tooling holes across the condenser tube sheet; refer to the following figures.

Important: Do NOT level the tooling holes from the evaporator to the condenser as they may be at different heights.

Figure 12. Leveling the chiller (front and left views)

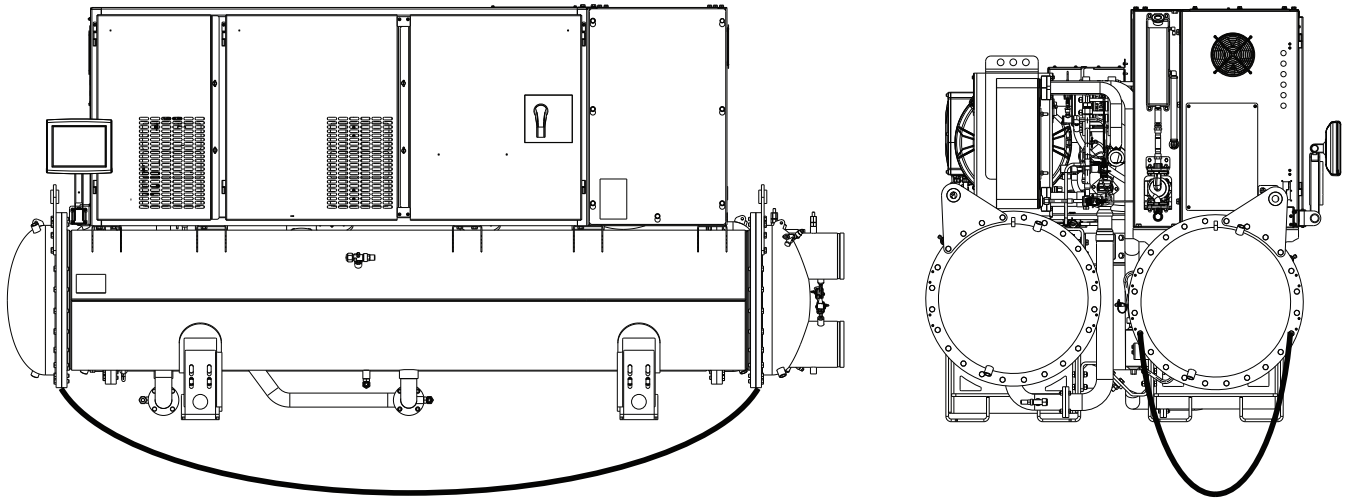
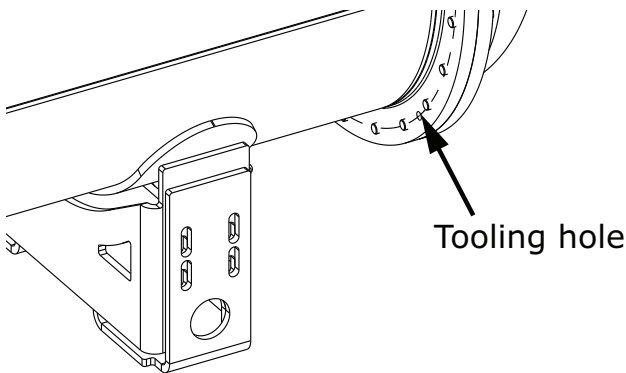
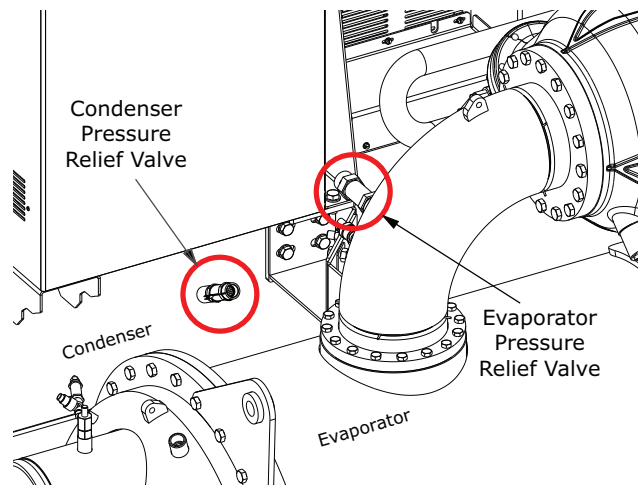

Figure 13. Leveling the chiller (tooling hole)



All HDWA chillers use evaporator and condenser pressure relief valves (refer to the following figure) that must be vented to the outside of the building.

Figure 14. Location of relief valves



Refrigerant Pressure Relief Valve Venting

⚠ WARNING

Confined Space Hazards!
 Failure to follow instructions below could result in death or serious injury.
 Do not work in confined spaces where refrigerant or other hazardous, toxic, or flammable gas may be leaking. Refrigerant or other gases could displace available oxygen to breathe, causing possible asphyxiation or other serious health risks. Some gases may be flammable and/or explosive. If a leak in such spaces is detected, evacuate the area immediately and contact the proper rescue or response authority.

Note: Vent pipe size must conform to the ANSI/ASHRAE Standard 15 for vent pipe sizing. All federal, state, and local codes take precedence over any suggestions stated in this manual.

All relief valve venting is the responsibility of the installing contractor.

Relief valve connection sizes and locations are shown in unit submittals. Refer to local codes for relief valve vent line sizing information.

NOTICE

Equipment Damage!
 Failure to comply with specifications may result in capacity reduction, unit damage and/or relief valve damage.
 Do NOT exceed vent piping code specifications!

Relief valve discharge setpoints and capacities rates are provided in the following table. After the relief valve has opened, it will re-close when pressure is reduced to a safe level.

Note: After they are opened, relief valves may have tendency to leak and must be replaced.

Pressure relief valve discharge capacities varies with shell diameter and length and also compressor displacement. Discharge venting capacity should be calculated as

required by ASHRAE Standard 15-94. Do NOT adjust relief valve setting in the field.

Table 8. Pressure relief valve data

Valve Location	Discharge Setpoint		Rated Capacity		Field Connection Pipe Size		Factory Shell Side Connection	
	psi	kPa	lb air/min.	kg air/min.	NPT	mm	in.	mm
Evaporator—Compressor Low Side Pipe (Suction)	200	1379.0	78.8	35.7	1-1/4	31.8	1-5/8 - 12	41.3 – 304.8
Condenser	300	2068.4	49.2	22.3	3/4	19.1	7/8 - 14	22.2 – 355.6



Freeze Protection

For unit operation in a low temperature environment, adequate protection measures must be taken against freezing. Refer to the following tables for adjusted settings

and recommended ethylene glycol and propylene glycol solution strengths.

- LRTC = Leaving Refrigerant Temperature Cutout
- LWTC = Leaving Water Temperature Cutout

Table 9. Agility chiller control settings based on ethylene glycol percentage

Ethylene Glycol Percentage, %	Solution Freeze Point		Minimum Recommended LRTC		Minimum Recommended LWTC	
	°F	°C	°F	°C	°F	°C
0	32.0	0.0	28.6	-1.9	34.0	1.1
2	31.0	-0.6	27.6	-2.5	33.0	0.5
4	29.7	-1.3	26.3	-3.2	31.7	-0.2
5	29.0	-1.7	25.6	-3.6	31.0	-0.6
6	28.3	-2.0	24.9	-3.9	30.3	-0.9
8	26.9	-2.8	23.5	-4.7	28.9	-1.7
10	25.5	-3.6	22.1	-5.5	27.5	-2.5
12	23.9	-4.5	20.5	-6.4	25.9	-3.4
14	22.3	-5.4	18.9	-7.3	24.3	-4.3
15	21.5	-5.9	18.1	-7.7	23.5	-4.7
16	20.6	-6.3	17.2	-8.2	22.6	-5.2
18	18.7	-7.4	15.3	-9.3	20.7	-6.3
20	16.8	-8.4	13.4	-10.3	18.8	-7.3
22	14.7	-9.6	11.3	-11.5	16.7	-8.5
24	12.5	-10.8	9.1	-12.7	14.5	-9.7
25	11.4	-11.4	8.0	-13.3	13.4	-10.3
26	10.2	-12.1	6.8	-14.0	12.2	-11.0
28	7.7	-13.5	4.3	-15.4	9.7	-12.4
30	5.1	-15.0	1.7	-16.8	7.1	-13.8
32	2.3	-16.5	-1.1	-18.4	5.0	-15.0
34	-0.7	-18.2	-4.1	-20.1	5.0	-15.0
35	-2.3	-19.0	-5.7	-20.9	5.0	-15.0
36	-3.9	-19.9	-7.3	-21.8	5.0	-15.0
38	-7.3	-21.8	-10.7	-23.7	5.0	-15.0
40	-10.8	-23.8	-14.2	-25.7	5.0	-15.0

Table 10. Agility chiller control settings based on propylene glycol percentage

Propylene Glycol Percentage, %	Solution Freeze Point		Minimum Recommended LRTC		Minimum Recommended LWTC	
	°F	°C	°F	°C	°F	°C
0	32.0	0.0	28.6	-1.9	34.0	1.1
2	31.0	-0.6	27.6	-2.4	33.0	0.6
4	29.9	-1.2	26.5	-3.1	31.9	-0.1
5	29.3	-1.5	25.9	-3.4	31.3	-0.4
6	28.7	-1.8	25.3	-3.7	30.7	-0.7
8	27.6	-2.5	24.2	-4.4	29.6	-1.4
10	26.4	-3.1	23.0	-5.0	28.4	-2.0
12	25.1	-3.8	21.7	-5.7	27.1	-2.7
14	23.8	-4.6	20.4	-6.5	25.8	-3.5
15	23.1	-5.0	19.7	-6.8	25.1	-3.8
16	22.4	-5.4	19.0	-7.2	24.4	-4.2
18	20.9	-6.2	17.5	-8.1	22.9	-5.1
20	19.3	-7.1	15.9	-9.0	21.3	-6.0

Table 10. Agility chiller control settings based on propylene glycol percentage (continued)

Propylene Glycol Percentage, %	Solution Freeze Point		Minimum Recommended LRTC		Minimum Recommended LWTC	
	°F	°C	°F	°C	°F	°C
22	17.6	-8.0	14.2	-9.9	19.6	-6.9
24	15.7	-9.0	12.3	-10.9	17.7	-7.9
25	14.8	-9.6	11.4	-11.5	16.8	-8.5
26	13.8	-10.1	10.4	-12.0	15.8	-9.0
28	11.6	-11.3	8.2	-13.2	13.6	-10.2
30	9.3	-12.6	5.9	-14.5	11.3	-11.5
32	6.8	-14.0	3.4	-15.9	8.8	-12.9
34	4.1	-15.5	0.7	-17.4	6.1	-14.4
35	2.7	-16.3	-0.7	-18.1	5.0	-15.0
36	1.3	-17.1	-2.1	-19.0	5.0	-15.0
38	-1.8	-18.8	-5.2	-20.7	5.0	-15.0
40	-5.2	-20.7	-8.6	-22.5	5.0	-15.0



Installation: Water Piping

Overview

The following water piping circuits must be installed and connected to the chiller:

- Pipe the evaporator into the chilled water circuit.
- Pipe the condenser into the cooling tower water circuit.

Note: Piping must be arranged and supported to avoid stress on the equipment. It is strongly recommended that the piping contractor does not run pipe closer than 3 ft (0.9 m) minimum to the equipment. This will allow for proper fit upon arrival of the unit at the job site. Any adjustment that is necessary can be made to the piping at that time. Once installed, refrigerant piping fixes unit in place. Expenses that result from a failure to follow this recommendation will NOT be paid by Trane.

Piping suggestions for each of the water circuits listed above are outlined in “Evaporator and Condenser Water Piping,” p. 29. General recommendations for the installation of field-supplied piping components (e.g., valves, flow switches, etc.) common to most chiller water circuits are listed in the following sections.

Water Treatment

The use of untreated or improperly treated water in a Agility™ chiller may result in inefficient operation and possible tube damage.

Important: Trane strongly recommends using the services of a qualified water treatment specialist to determine necessary water treatment. A label with a customer disclaimer note is affixed to each unit.

NOTICE

Proper Water Treatment Required!

The use of untreated or improperly treated water could result in scaling, erosion, corrosion, algae or slime.

Use the services of a qualified water treatment specialist to determine what water treatment, if any, is required. Trane assumes no responsibility for equipment failures which result from untreated or improperly treated water, or saline or brackish water.

Water Pressure Gauges

Locate pressure gauge taps in a straight length of pipe. Place each tap a minimum of one pipe diameter downstream of any elbow, orifice, etc. For example, for a 6 in. (16 cm) pipe, the tap would be at least 6 in. (16 cm) from any elbow, orifice, etc.

Valves – Drains and Vents

NOTICE

Waterbox Damage!

Failure to follow instructions could result in damage to the waterbox.

Do not over-tighten or use excessive Teflon® pipe tape when installing valves, drains, plugs and vents on waterboxes.

1. Install field-supplied air vents and drain valves on the waterboxes. Each waterbox is provided with a National Pipe Thread Female (NPTF) vent and drain connection; depending on the waterbox types ordered, the openings may be 1/4 in. (6.35 mm), 1/2 in. (12.7 mm), or 3/4 in. (19.05 mm).

NOTICE

Waterbox Damage!

Failure to follow instructions could result in damage to the waterbox due to hydrostatic expansion.

Install pressure-relief valves in the condenser and evaporator water circuits.

NOTICE

Equipment Damage!

Failure to follow instructions could result in equipment damage.

Do NOT allow chiller to freeze! Bundles must be drained and air-blown dry if chiller is stored in an unheated equipment room.

2. If necessary for the application, install pressure-relief valves at the drain connections on the evaporator and condenser waterboxes. To do so, add a tee with the relief valve attached to the drain valve.

To determine whether or not pressure relief valves are needed for a specific application, keep in mind that:

- a. Vessels with close-coupled shutoff valves may cause high potentially damaging hydrostatic pressures as fluid temperature rises.
- b. Relief valves are required by American Society of Mechanical Engineers (ASME) codes when the shell waterside is ASME. Follow ASME guidelines or other applicable codes to ensure proper relief valve installation.

Strainers

NOTICE

Water Borne Debris!

To prevent components damage, pipe strainers must be installed in the water supplies to protect components from water borne debris. Trane is not responsible for equipment-only-damage caused by water borne debris.

Install a strainer in the entering side of each piping circuit to avoid possible tube plugging in the chiller with debris.

Required Flow-Sensing Devices

The ifm efector® flow detection controller and sensor (refer to “Water Flow Detection Controller and Sensor,” p. 27) is used to verify evaporator and condenser water flows.

If a customer-supplied flow sensing device is used to ensure adequate chiller flow protection, refer to the wiring diagrams that shipped with the unit for specific electrical connections.

Be sure to follow the manufacturer’s recommendations for device selection and installation.

Water Flow Detection Controller and Sensor

Important: Before installing the ifm efector® flow detection controller and sensor, use a marker to draw a line on the probe at 3.5 in. (8.9 cm) from the end of the probe. Do NOT insert more than 3.5 in. (8.9 cm) of the probe length into the pipe. Refer to the following figure.

Figure 15. Installation of ifm efector flow detection controller and sensor

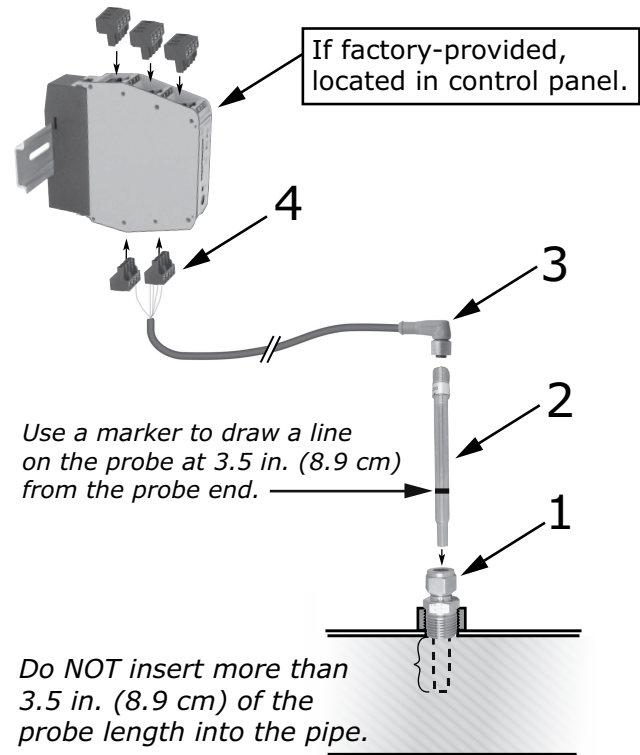
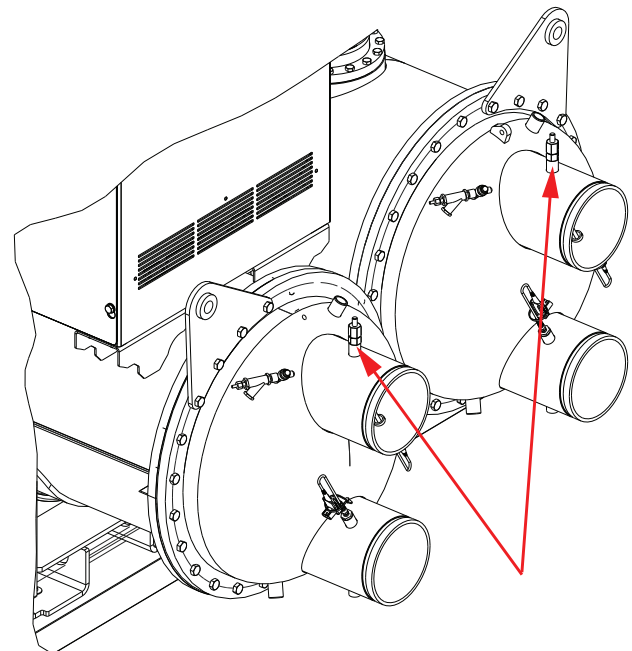

Figure 16. Location of ifm efector flow detection controller and sensor



Note: In Agility™ chillers, the ifm efector® flow detection controller and sensor is mounted in the waterbox nozzle, as shown in the preceding figure.

1. Mount the 1/2-in. NPT adapter in a horizontal or vertical

section of pipe. The maximum distance from the control panel must not exceed 29.5 ft (9 m) (see item labeled “1” in the preceding figure). Allow at least five pipe diameters straight run of pipe upstream of the sensor location, and three pipe diameters straight run of pipe downstream of the sensor location.

Notes:

- In Agility™ chillers, the ifm efector® flow detection controller and sensor is mounted in the waterbox nozzle, as shown in the preceding figure.
- If the ifm efector® flow detection controller and sensor is mounted in an alternate location on a horizontal pipe, mounting the sensor in the side of the pipe is preferred; in the case of a vertical pipe, mounting the sensor in a place where the water flows upwards is preferred.

NOTICE

Overtightening!
Do not exceed torque specifications as it could result in equipment damage.

2. Insert the flow sensor probe (see item labeled “2” in the preceding figure) through the 1/2-in. NPT adapter so that 3 to 3.5 in. (7.6 to 8.9 cm) of the probe’s length extends into the pipe. Tighten the 1/2-in. NPT adapter as needed to prevent leakage and keep the probe from backing out under pressure. **Do NOT exceed 40 ft·lb (54.2 N·m) of torque on the fitting. Sensor damage can occur if it is overtightened.**

Note: When installed, the tip of the ifm efector® sensor probe must be at least 1 in. (2.54 cm) away from any pipe wall. Do NOT insert more than 3.5 in. (8.9 cm) of the probe length into the pipe.

3. Install the Micro DC Cable by inserting it through the wire openings on the back side of the control panel (see item labeled “3” in the preceding figure). Install the supplied Micro DC Cable (29.5 ft [9 m] in length) to the Flow Probe and hand-tighten the connector nut.
4. Plug the other end of the Micro DC Cable into the Flow Control Monitor with the Combicon connector (see item labeled “4” in the preceding figure). Refer to the following figure for cable wiring.

NOTICE

Do Not Apply Electrical Power to a Unit in a Vacuum!
Failure to follow instructions below could result in motor and compressor damage.
Do not apply electrical power to a motor in a vacuum.

5. Apply power to the chiller control panel to verify the Flow Control Monitor has power and the Low Volt Broken Wire Relay is NOT lit.

6. Remove all air from the piping circuit prior to adjusting the low water flow setpoint.
7. Reduce the water flow to the minimum allowable flow and adjust the Flow setting on the Flow Control Monitor (see item labeled “7” in the following figure). Adjusting the “Flow” potentiometer clockwise (+) reduces the flow setting cutout and adjusting counterclockwise (-) increases the flow setting cutout.

Note: The “Temp” potentiometer on the ifm efector® control module has no effect in Trane application. It is NOT necessary to make adjustments to the “Temp” potentiometer.

8. After the cutout setting is adjusted, the cutout setpoint will be indicated with a yellow light on the Flow Control Monitor LED bar graph display. When the water flows are higher than the cutout, a green light will indicate proper flow status. If the flows fall below the cutout setpoint, a red light will indicate low/no flow status.

Figure 17. ifm efector® flow sensing device terminal connection

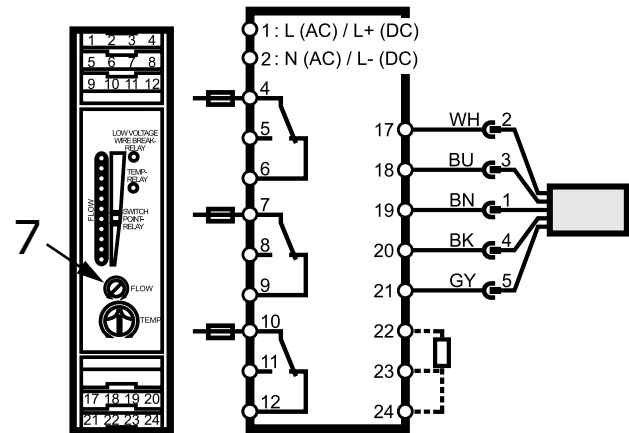

NOTICE

Proof of Flow Switch!
Failure to provide flow switches or jumping-out of switches could result in severe equipment damage. Evaporator and condenser water circuits require proof of flow switches.

- Failure to include the proof of flow devices and/or jumping out these devices could cause the unit to stop on a secondary level of protection.
- Frequent cycling on these higher level diagnostic devices could cause excessive thermal and pressure cycling of unit components (O-rings, gaskets, sensors, motors, controls, etc.) and/or freeze damage, resulting in premature failure of the chiller.

Evaporator and condenser proof of flow switches are required. These switches are used with control logic to confirm flow prior to starting a unit and to stop a running unit if flow is lost. For troubleshooting, a viewable diagnostic is generated if a proof of flow switch does not close when flow is required.

Evaporator and Condenser Water Piping

The following two figures illustrate the recommended (typical) water piping arrangements for the evaporator and condenser.

Figure 18. Typical evaporator water piping circuit

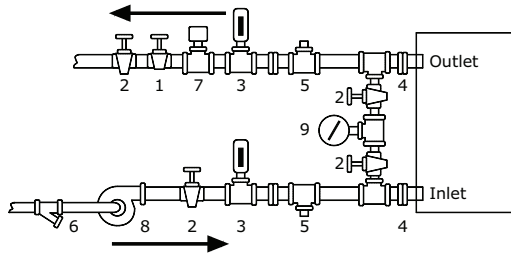

1. Balancing valve.
2. Gate (Isolation) valve or ball valve.
3. Thermometer (if field supplied).
4. Waterbox nozzle connection.
5. Drain, vent, and anode.
6. Strainer.
7. Chilled water flow switch (5S1). Flow switch 5S1 may be installed in either the entering or leaving leg of the chilled water circuit.
8. Pump.
9. Pressure gauge. It is recommended to pipe the gauge between entering and leaving pipes. A shutoff valve on each side of the gauge allows the operator to read either entering or leaving water pressure.

Figure 19. Typical condenser water piping circuits

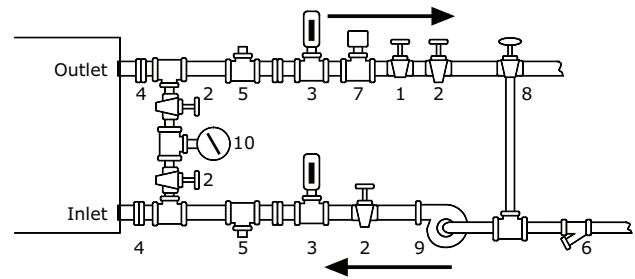

1. Balancing valve.
2. Gate (isolation) valve or ball valve.
3. Thermometer (if field supplied).
4. Waterbox nozzle connection.
5. Drain, vent, and anode.
6. Strainer.
7. Condenser water flow switch (5S2). Flow switch 5S2 may be installed in either the entering or leaving leg of the chilled water circuit.
8. Three-way valve (optional).
9. Condenser water pump.
10. Pressure gauge. It is recommended to pipe a single gauge between entering and leaving pipes.

Piping must be arranged and supported to avoid stress on the equipment. It is strongly recommended that the piping contractor does not run pipe closer than 3 ft (0.9 m) minimum to the equipment. This will allow for proper fit upon arrival of the unit at the job site. Any adjustment that is necessary can be made to the piping at that time. Expenses that result from a failure to follow this recommendation will NOT be paid by Trane.

Water piping connection sizes and components are identified in the tables in [“Water Piping Connections,” p. 30](#) and [“Grooved Pipe Coupling,” p. 31](#). Remember that with many waterboxes, the entering and leaving evaporator water can be piped to either waterbox connection when the tube bundles are split vertically. However, large evaporator waterboxes with entering and leaving connections not at the same level must be connected with the entering water at the bottom and the leaving water at the top.

Waterboxes with multiple pass arrangements utilize a baffle to separate the passes. These baffles are designed for a maximum pressure of 20 psid (137.9 kPaD). If larger pressure drops are expected in the application, contact your local Trane representative to discuss special waterbox options.

Important: *Water flows must be piped in accordance with nameplate designation.*

Field-provided isolation valves for the evaporator and condenser water lines should be installed upstream and downstream of the heat exchangers, and be installed far enough away from the chiller to also provide practical service isolation for flow sensing devices, field

Installation: Water Piping

thermometers, flexible connectors, and any removable pipe spools.

Ensure that the evaporator water piping is clear; check it after the chilled water pump is operated but before initial chiller start-up. If any partial blockages exist, they can be detected and removed to prevent possible tube damage resulting from evaporator freeze-up or erosion.

For condenser and evaporator connections, arrange the water piping so that the water supply enters the shell at the lower connection and exits from the top connection. Operational problems may result if this piping is not correct.

For applications that include an “infinite source” or “multiple-use” cooling condenser water supply, install a valved bypass “leg” (optional) between the supply and return pipes. This valved bypass allows the operator to short-circuit water flow through the cooling condenser when the supply water temperature is too low.

Water Piping Connections

All standard units use grooved-pipe connections. These are grooved-end NSP (Victaulic® style) pipe connections. Flanged connections are optional.

Piping joined using grooved type couplings, like all types of piping systems, requires proper support to carry the weight of pipes and equipment. The support methods used must eliminate undue stresses on joints, piping, and other components, allow movement where required, and provide for any other special requirements (i.e., drainage, etc.).

Note: If needed, plug-type sensor extension cables are available for purchase from Trane Parts Service. These sensor extension cables may be necessary if the waterboxes are changed or if the temperature sensors are moved out into the unit piping for better mixed temperature readings.

Table 11. Water connection pipe sizes

EVSZ/CDSZ	Nominal Pipe Size	
	2 Pass	
	in.	mm
020	6	168.3
040	8	219.1

Figure 20. Typical grooved pipe connection

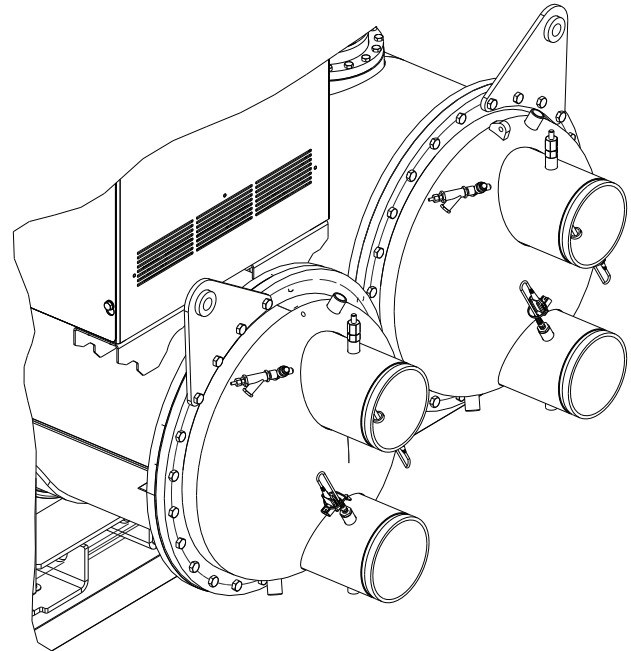

Waterbox Locations

Note: Do NOT interchange evaporator and condenser waterboxes. Supply evaporator waterbox and tubesheet contain match marks to aid in identifying matching shells and waterboxes.

If removal of waterboxes is necessary, refer to “Waterbox Removal,” p. 68.

If the waterboxes on any of the shells are exchanged end-for-end, be sure to reinstall them right-side up to maintain the correct baffle arrangements. Use a new gasket with each waterbox cover.

Reversing Waterboxes

All waterboxes can be reversed end-for-end. Refer to “Waterbox Removal,” p. 68 for detailed waterbox removal instructions.

Remove sensors from wells before removing waterbox.

Do NOT rotate waterboxes.

Complete the waterbox switch and replace sensors.

Notes:

- If waterboxes are reversed, be sure to properly rewire water temperature sensors in the control panel.
- Be sure to replace waterboxes right-side-up to maintain proper baffle orientation. Use new O-rings.
- If the waterbox is reversed, be sure to match mark on the baffle and the waterbox to ensure they are aligned.

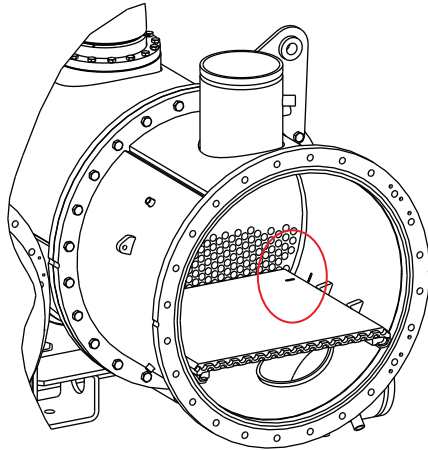

Grooved Pipe Coupling

A customer-supplied, standard flexible grooved pipe coupling (Victaulic® Style 77 or equivalent) should be used to complete the Victaulic® connection for both 150 psig (1034.2 kPaG) and 300 psig (2068.4 kPaG) waterboxes.

When a flexible coupling such as this is installed at the waterbox connections, other flexible piping connectors (i.e., braided-steel, elastomeric arch, etc.) are not usually required to attenuate vibration and/or prevent stress on the connections.

Figure 21. Customer piping connection types

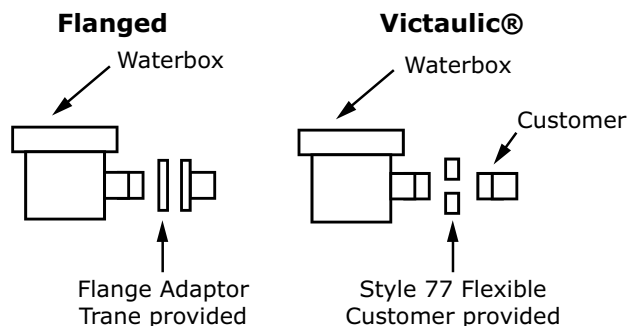
Notes:

- Refer to the coupling manufacturer's guidelines for specific information concerning proper piping system design and construction methods for grooved water piping systems.
- Flexible coupling gaskets require proper lubrication before installation to provide a good seal. Refer to the coupling manufacturer's guidelines for proper lubricant type and application.

Flange-connection Adapters

NOTICE

Never Weld to Cast Boxes!

Welding to cast boxes will result in equipment damage.

Adapters must be used to convert flanges.

When flat-face flange connections are specified, flange-to-groove adapters are provided (Victaulic® Style 741 for 150 psig [1034.2 kPaG] systems; Style 743 for 300 psig [2068.4 kPaG] systems). The adapters are shipped in spare parts box included with the unit. Adapter descriptions are given in the tables in "Victaulic Gasket Installation," p. 32. The flange adapters provide a direct, rigid connection of flanged components to the grooved-pipe chiller waterbox connections.

In this case, the use of flexible type connectors (i.e., braided steel, elastomeric arch, etc.) are recommended to attenuate vibration and prevent stress at the waterbox connections.

All flange-to-flange assembly screws must be provided by the installer. Hex head screw sizes and number required are included in the tables in "Victaulic Gasket Installation," p. 32. The Style 741 (150 psig [1034.2 kPaG]) flange adapter requires a smooth, hard surface for a good seal.

Connection to other type flange faces (i.e., raised, serrated, rubber, etc.) requires the use of a flange washer between the faces. Refer to the flange adapter manufacturer's guidelines for specific information.

The Style 743 (300 psig [2068.4 kPaG]) flange adapters are designed to mate with raised-face flanges. They can be used with flat-faced flanges, but only if the raised projections on the outside face of the adapter are removed; refer to the following figure. The flange-adapter gasket must be placed with the color-coded lip on the pipe and the other lip facing the mating flange.

NOTICE

Piping Connection Leaks!

Failure to provide effective seal could result in equipment or property-only damage.

To provide effective seal, gasket contact surfaces of adapter must be free of gouges, undulations or deformities.

Installation: Water Piping

Figure 22. Modifying 300 psig (2068.4 kPaG) flange adaptors for flat-faced flange application

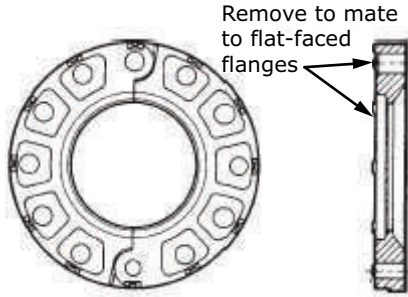

4. Open fully and place hinged Victaulic® flange around the grooved pipe end with the circular key section locating into the groove.
5. Insert a standard hex head screw through the mating holes of the Victaulic® flange to secure the flange firmly in the groove.
6. Tighten fasteners alternately and equally until housing screw pads are firmly together (metal-to-metal); refer to “Screw-Tightening Sequence for Water Piping Connections,” p. 32. Do NOT excessively tighten fasteners.

Note: Uneven tightening may cause the gasket to pinch.

Victaulic Gasket Installation

1. Inspect supplied gasket to be certain it is suited for intended service (code identifies gasket grade). Apply a thin coat of silicone lubricant to gasket tips and outside of gasket.
2. Install gasket, placing gasket over pipe end and making sure gasket lip does not overhang pipe end. Refer to the following figure for gasket configuration.
3. Align and bring two pipe ends together and slide gasket into position centered between the grooves on each pipe. No portion of the gasket should extend into the groove on either pipe.

Figure 23. Typical Victaulic® flange gasket configuration

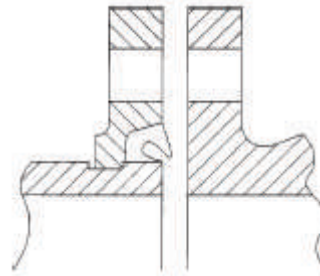

Table 12. Installation data for 150 psig (1034.2 kPaG) flange adaptors (Style 741)

Nominal Pipe Size		Assembly Screw Size ^(a)	Number of Assembly Screws Required	Screw Pattern Diameter		Weight	
in.	mm			in.	mm	lb	kg
6	168.3	3/4 x 3-1/2	8	9.5	241	10.3	4.7
8	219.1	3/4 x 3-1/2	8	11.75	298	16.6	7.5

^(a) Screw size for conventional flange-to-flange connection. Longer screws are required when flange washer must be used. Grade 5 screws are recommended.

Table 13. Installation data for 300 psig (2068.4 kPaG) flange adaptors (Style 743)

Nominal Pipe Size		Assembly Screw Size ^(a)	Number of Assembly Screws Required	Screw Pattern Diameter		Weight	
in.	mm			in.	mm	lb	kg
6	168.3	3/4 x 4-1/2	12	10.63	270	23.4	10.6
8	219.1	3/4 x 4-3/4	12	13	330	34.3	15.6

^(a) Screw size for conventional flange-to-flange connection. Longer screws are required when flange washer must be used.

Screw-Tightening Sequence for Water Piping Connections

This section describes a screw-tightening sequence for flanges with flat gaskets or O-rings. Remember that improperly tightened flanges may leak.

Note: Before tightening any of the screws, align the flanges.

Flanges with 8 or 12 Screws

Tighten all screws to a snug tightness, following the numerical sequence for the appropriate pattern as shown

in the following figure. Repeat this sequence to apply the final torque to each screw.

Figure 24. Flange screw tightening sequence (8 or 12 screws)

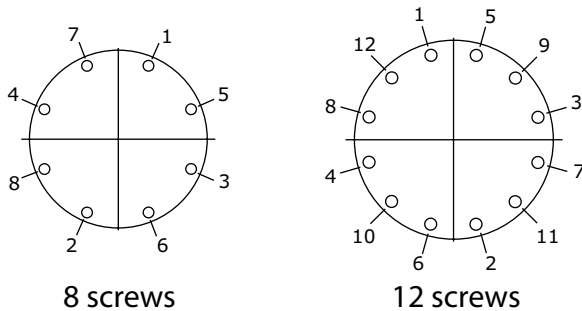

Waterside design pressure is 150 psig (1034.2 kPaG) or 300 psig (2068.4 kPaG); refer to unit nameplate or to submittal documentation.

Eddy Current Testing

Trane recommends conducting an eddy current inspection of the condenser and evaporator tubes in water-cooled chillers every three years. Eddy current tests are intended to identify defects on or within the walls of heat exchanger tubing that could lead to in-service tube failures. Eddy current tests conducted before a chiller is put into service are considered “baseline” eddy current tests, and are intended to establish a reference point to aid in the interpretation of future eddy current test reports. Many of the anomalies that can be found through eddy current testing have no impact on tube life or performance, while others are severe enough to justify removing the affected tube from service. Ask your sales account manager for a copy of the engineering bulletin (CTV-PRB024*-EN) for clarification of the role of eddy current testing in chiller maintenance by providing information about eddy current technology and heat exchanger tubing.

Pressure Testing Waterside Piping

NOTICE

Equipment Damage!

Failure to follow these instructions could result in equipment damage.

Do not over pressurize the system or exceed design pressure. Always perform a hydro pressure test with water present in piping and waterboxes.



Insulation

Unit Insulation Requirements

Factory-installed insulation is available as an option for all units. Factory installation does NOT include insulation of the chiller feet. In applications where the chiller is not factory-insulated, install insulation over all surfaces shown in the figure in “Factory-applied Insulation,” p. 34 (i.e., compressor, condenser, economizer, and drive [not shown]).

The quantity of insulation required is listed in the following table. Insulation thickness is determined at normal design conditions which are:

- Standard comfort-cooling leaving chilled water temperature
- 85°F (29.4°C) dry bulb ambient temperature
- 75 percent relative humidity

Operation outside of normal design conditions as defined in this section may require additional insulation; contact Trane for further review.

Note: *If the unit is not factory-insulated, install insulation around the evaporator bulbwells and ensure that the bulbwells and connections for the waterbox drains and vents are still accessible after insulation is applied. The sensor modules (Low Level Intelligent Devices [LLIDs]) and interconnecting four-wire cable inter-processor communication (IPC) bus must be raised up above the field-installed insulation. Secure the IPC bus to the insulation top/outer surface after insulation is completed.*

Important: *Do NOT insulate the compressor, motor housing, unit wiring, or sensor modules.*

Table 14. Agility chiller insulation requirements

Location	3/4 in. (19.05 mm) Insulation, Square Feet (Square Meters)
020A Evaporator, suction elbow, pipe	105 (9.8)
040A Evaporator, suction elbow, pipe	120 (11.1)

Insulation Thickness Requirements

Factory-applied Insulation

All low-temperature surfaces are covered with 3/4 in. (19.05 mm) Armaflex® II or equal.

The insulation is Armaflex® or equivalent closed cell elastomeric insulation to prevent the formation of condensation. Chillers in high humidity areas or ice storage, low leaving water temperature (less than 36°F [2.2°C] chilled water temperature/glycol) units, may require double thickness to prevent formation of condensation.

NOTICE

Insulation Damage!

Failure to follow these instructions could result in insulation damage.

To prevent damage to factory installed insulation:

- **Do not allow the insulation to be exposed to excessive sunlight. Store indoors or cover with canvas to prevent exposure.**
- **Do not use thinners and solvents or other types of paint. Use only water base latex.**

Figure 25. Recommended area for unit insulation

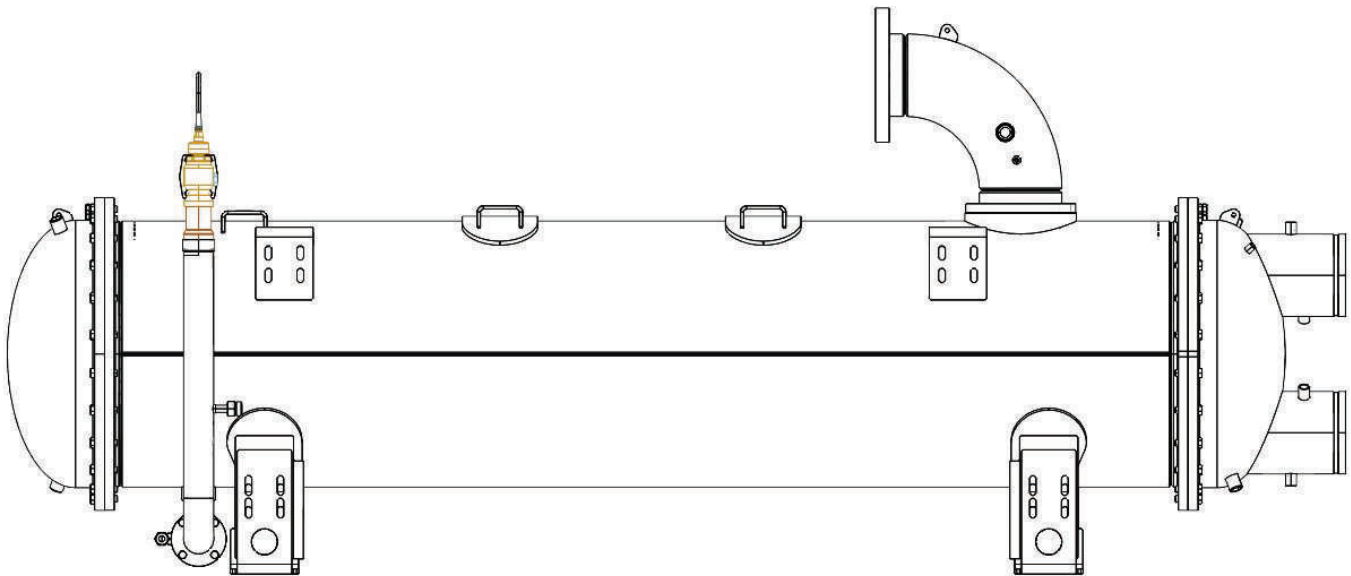

Notes:

- *Bulbwells, drain, and vent connections must be accessible after insulating.*
- *All units with evaporator marine waterboxes: wrap waterbox shell insulation with strapping and secure strapping with seal.*
- *Evaporators with ASME nameplates must have insulation cut out around the nameplate. Do NOT glue insulation to the nameplate.*
- *Apply 2-in. (50.8-mm) wide black tape on overlap joints. Where possible, apply 3-in. (76.2-mm) wide strip of 0.38-in. (9.652-mm) thick insulation over butt joint seams.*



Electrical Requirements

Installation Requirements

⚠ WARNING

Proper Field Wiring and Grounding Required!

Failure to follow code could result in death or serious injury.

All field wiring **MUST** be performed by qualified personnel. Improperly installed and grounded field wiring poses **FIRE** and **ELECTROCUTION** hazards. To avoid these hazards, you **MUST** follow requirements for field wiring installation and grounding as described in **NEC** and your local/state/national electrical codes.

NOTICE

Use Copper Conductors Only!

Failure to use copper conductors could result in equipment damage as the equipment was not designed or qualified to accept other types of conductors.

Unit-mounted Adaptive Frequency™ Drives (AFDs) are standard on all units. While this option eliminates most field-installed wiring requirements, the electrical contractor must still complete the electrical connection for the following:

- power supply wiring to the AFD
- other unit control options present
- any field-supplied control devices
- Air-Fi®
- Wi-Fi

As you review this manual along with the wiring instructions presented in this section, keep in mind that:

- All field-installed wiring must conform to National Electric Code (NEC) guidelines, and any applicable local, state, and national codes. Be sure to satisfy proper equipment grounding requirements per NEC.
- Compressor motor and unit electrical data (including motor kW, voltage utilization range, rated load amps, and locked rotor amps) is listed on the chiller nameplate.
- Use copper conductors to connect the three-phase power supply to the AFD's Line Potential Main Circuit Breaker.
- All field-installed wiring must be checked for proper terminations, and for possible shorts or grounds.

Note: Always refer to the actual wiring diagrams that shipped with the chiller or the unit submittal for specific as-built electrical schematic and connection information.

NOTICE

Adaptive Frequency Drive (AFD)/Starter Component Damage!

Failure to remove debris from inside the AFD/starter panel could result in an electrical short and could cause serious AFD/starter component damage.

Do NOT modify or cut enclosure to provide electrical access. Removable panels have been provided, and any modification should be done away from the enclosure. If the AFD enclosure must be cut to provide electrical access, exercise care to prevent debris from falling inside the enclosure. Refer to submittal drawings.

Electrical Requirements

Before wiring begins, observe the following electrical requirements:

- Follow all lockout/tagout procedures prior to performing installation and/or service on the unit.
- Always wear appropriate personal protective equipment.
- Wait the required time to allow the capacitor(s) to discharge; this could be up to 30 minutes.
- Verify that all capacitors are discharged prior to service using a properly rated volt meter.
- Use appropriate capacitor discharge tool when necessary.
- Comply with the safety practices recommended in PROD-SVB06*-EN.

⚠ WARNING

Hazardous Voltage w/Capacitors!

Failure to disconnect power and discharge capacitors before servicing could result in death or serious injury.

Disconnect all electric power, including remote disconnects and discharge all motor start/run capacitors before servicing. Follow proper lockout/tagout procedures to ensure the power cannot be inadvertently energized. For variable frequency drives or other energy storing components provided by Trane or others, refer to the appropriate manufacturer's literature for allowable waiting periods for discharge of capacitors. Verify with a CAT III or IV voltmeter rated per NFPA 70E that all capacitors have discharged.

⚠ WARNING

Personal Protective Equipment (PPE) Required!

Failure to wear PPE and follow proper handling guidelines could result in death or serious injury. Always wear appropriate personal protective equipment in accordance with applicable regulations and/or standards to guard against potential electrical shock and flash hazards.

⚠ WARNING

Live Electrical Components!

Failure to follow all electrical safety precautions when exposed to live electrical components could result in death or serious injury. When it is necessary to work with live electrical components, have a qualified licensed electrician or other individual who has been properly trained in handling live electrical components perform these tasks.

Adaptive Frequency Drive

Table 15. Adaptive Frequency Drive (AFD) electrical data — Tmax circuit breakers 460/480 and 575/600 volts

Input Voltage	Maximum RLA	Tmax Breaker AIC Amps	Short Circuit Withstand Rating	Line Connection Lugs
460V / 60Hz	678	65,000	65,000	(4) 4/0 - 500 MCM
	535	65,000	65,000	(3) 2/0 - 400 MCM
	443	65,000	65,000	(2) 3/0 - 250 MCM
	361	65,000	65,000	(2) 3/0 - 250 MCM
	240	65,000	65,000	(2) 3/0 - 250 MCM
575V / 60Hz	678	65,000	65,000	(3) 2/0 - 400 MCM
	535	65,000	65,000	(2) 2/0 - 250 MCM
	443	65,000	65,000	(2) 3/0 - 250 MCM
	361	65,000	65,000	(2) 3/0 - 250 MCM
	240	65,000	65,000	(2) 3/0 - 250 MCM

Table 16. Adaptive Frequency Drive (AFD) electrical data — XT circuit breakers 460/480 and 575/600 volts

Input Voltage	Maximum RLA	XT Breaker AIC Amps	Short Circuit Withstand Rating	Line Connection Lugs
460V / 60Hz	678	65,000	65,000	(4) 4/0 - 500 MCM
	535	65,000	65,000	(3) 2/0 - 400 MCM
	443	65,000	65,000	(2) 2/0 - 500 MCM
	361	65,000	65,000	(2) 2/0 - 500 MCM
	240	65,000	65,000	(2) 2/0 - 500 MCM
575V / 60Hz	678	65,000	65,000	(4) 4/0 - 500 MCM
	535	65,000	65,000	(2) 2/0 - 500 MCM
	443	65,000	65,000	(2) 2/0 - 500 MCM
	361	65,000	65,000	(2) 2/0 - 500 MCM
	240	65,000	65,000	(2) 2/0 - 500 MCM

The main circuit breaker within the AFD panel is affixed with a dial, labeled “Ir”, to set the trip current of the breaker. See tables below for the factory “Ir” dial setting for 400 amp and 600 amp (L-frame) circuit breakers, and for the 800 amp and 1200 amp (P-frame) circuit breaker “Ir” dial settings. These values are based on the panel SRRL and IVLT values found on the unit nameplate.

Table 17. Breaker Ir dial setting, L-frame breakers(400 and 600 amp)

Breaker Ir Dial Setting	IVLT				
	575/600	460/480	380/400/415	208	
SRRL	532/533	600	-	-	-
	439/440	500	600	600	-
	362/363	400	500	500	-
	238/243	300	400	-	-

Table 18. Breaker Ir dial setting, P-frame breakers(800 and 1200 amp)

Breaker Ir Dial Setting	IVLT				
	575/600	460/480	380/400/415	208	
SRRL	675	0.9	0.9	0.9	-
	532	-	1	1	-
	439/440	-	-	-	1
	362/363	-	-	-	0.9

System Control Circuit Wiring (Field Wiring)

Figure 26. HDWA Agility chiller field wiring

NOTES:

- DO NOT ROUTE LOW VOLTAGE (30V) WITH CONTROL VOLTAGE (120V) AND DO NOT POWER UNIT UNTIL CHECK OUT AND START UP PROCEDURES HAVE BEEN COMPLETED.
- DASHED LINES INDICATE FIELD WIRING BY OTHERS. WIRE NUMBERS SHOWN ARE RECOMMENDED BY TRANE. REFER TO THE UNIT TO DETERMINE WHICH OPTIONS ARE PRESENT.
- ALL FIELD WIRING MUST BE IN ACCORDANCE WITH THE NATIONAL ELECTRIC CODE (NEC), STATE AND LOCAL CODES.
- CLASS 1 FIELD WIRING INSULATION RATING IS REQUIRED TO BE EQUAL TO OR BE GREATER THAN THE EQUIPMENT SUPPLY VOLTAGE RATING. CLASS 2 FIELD WIRING INSULATION IS REQUIRED TO BE RATED AT 300V MINIMUM. ALL CUSTOMER CONTROL CIRCUIT WIRING IS MADE TO CIRCUIT BOARD MOUNTED BOX LUGS WITH A WIRE RANGE OF 14-18 AWG OR TO DIN RAIL MOUNTED SPRING FORCE TERMINALS.
- ALL UNIT POWER WIRING MUST BE 600V COPPER CONDUCTOR ONLY. REFER TO THE UNIT NAMEPLATE FOR MINIMUM CIRCUIT AMPACITY AND MAXIMUM OVERCURRENT PROTECTION DEVICE. PROVIDE AN EQUIPMENT GROUND IN ACCORDANCE WITH APPLICABLE ELECTRIC CODES.
- UNIT PROVIDED DRY CONTACTS FOR WATER PUMP CONTROL RELAY RATING AT 120VAC, 7.2A RESISTIVE, 2.88A PILOT DUTY, 1/3 HP, 7.2 FLA RELAY RATING AT 240VAC, 5A GENERAL PURPOSE.
- TRANE RECOMMENDS WIRING THE 5K1 EVAPORATOR AND 5K2 CONDENSER WATER PUMP CONTROL RELAYS AS SHOWN TO ALLOW THE 1K12 MODULE TO CONTROL PROPER SEQUENCING. EVAPORATOR CHILLED WATER PUMP MUST BE CONTROLLED BY THE CHILLER OUTPUT. FAILURE TO DO SO MAY RESULT IN DAMAGE TO THE UNIT.
- CUSTOMER SUPPLIED CONTACTS FOR ALL LOW VOLTAGE CONNECTIONS MUST BE COMPATIBLE WITH DRY CIRCUIT 24VDC FOR A 12mA RESISTIVE LOAD. SILVER OR GOLD PLATED CONTACTS ARE RECOMMENDED.
- INSTALLATION OF PRIMARY EVAPORATOR AND CONDENSER WATER PROOF OF FLOW DEVICES ARE REQUIRED. THESE ARE INDICATED AS SS11 AND SS12 CUSTOMER SUPPLIED DEVICES AND MUST BE A FLOW SENSING DEVICE SUCH AS A FLOW SWITCH, WATER FLOW DETECTION CONTROLLER OR A DIFFERENTIAL PRESSURE SWITCH. PRIMARY EVAPORATOR AND CONDENSER WATER PROOF OF FLOW IS ALSO SHOWN USING OPTIONAL TRANE INSTALLED 1K22 AND 1K23 WATER FLOW DETECTION CONTROLLERS. 4R17 AND 4R18 WATER FLOW DETECTION SENSORS AND WB11 AND WB12 CABLES ARE SUPPLIED BY TRANE FOR FIELD INSTALLATION BY THE CUSTOMER.
- INSTALLATION OF CUSTOMER SUPPLIED SECONDARY EVAPORATOR AND CONDENSER WATER PROOF OF FLOW DEVICES ARE AT THE DISCRETION OF THE CUSTOMER. THESE ARE INDICATED AS SS17 AND SS18 AND MAY BE A WATER PUMP INTERLOCK, VALVE END SWITCH OR ANY OTHER PROOF OF FLOW DEVICE. TRANE RECOMMENDS INSTALLATION OF THE SS17 SECONDARY EVAPORATOR WATER PROOF OF FLOW DEVICE WHEN THE LEAVING WATER TEMPERATURE IS EXPECTED TO BE 38F OR LESS AND THAT THE METHOD USED IS INDEPENDENT OF THE PRIMARY WATER PROOF OF FLOW DEVICE TO PROVIDE REDUNDANCY.
- IF OPTIONAL TRANE INSTALLED 1K22 AND/OR 1K23 WATER FLOW DETECTION CONTROLLERS ARE USED AND THE CUSTOMER CHOOSES TO INSTALL SS17 AND/OR SS18 SECONDARY WATER PROOF OF FLOW DEVICES THEN THE CUSTOMER MUST REMOVE TRANE FACTORY WIRE 220E BETWEEN 1X1-2 AND 1K23-4 AND/OR TRANE FACTORY WIRE 220G BETWEEN 1X1-3 AND 1K22-4. REFER TO THE UNIT SCHEMATIC WIRING DIAGRAM. SECONDARY WATER PROOF OF FLOW DEVICES WOULD THEN BE INSTALLED AS SHOWN.

DEVICE	FUSE TYPE	FUSE SIZE
2F1	CLASS CC	15A
2F2	CLASS CC	15A
2F3	CLASS CC	10A
2F4	CLASS CC	10A
2F5	CLASS CC	5A
2F7	CLASS CC	5A
2F8	CLASS CC	20A
2F11	BUSSMANN - 170M3467	315A
2F12	BUSSMANN - 170M3467	315A

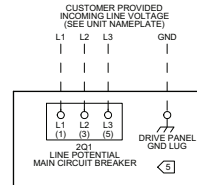
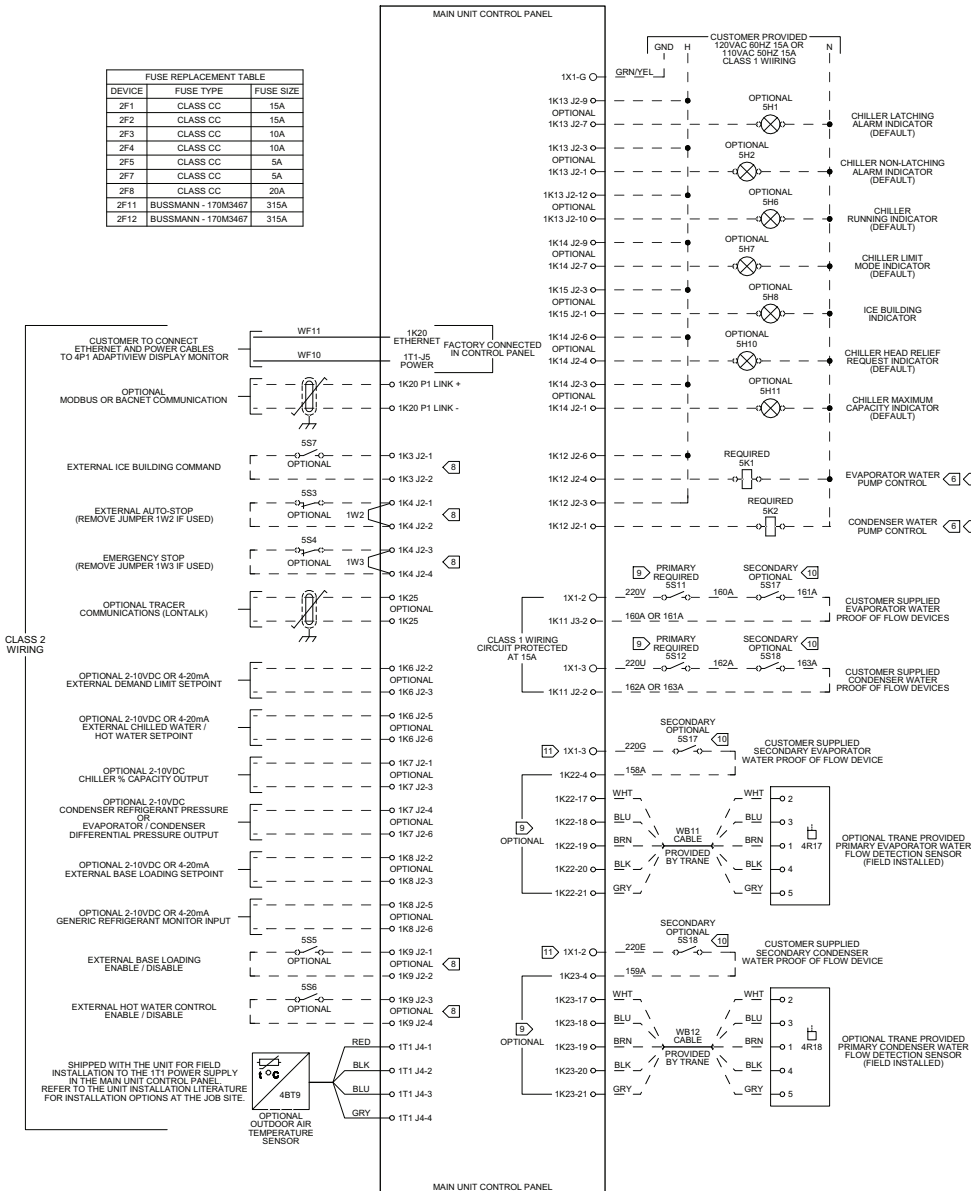

ANY 1K13 OR 1K14 DEFAULT OUTPUT MAY BE REPROGRAMMED TO THE ALTERNATE STATUS OUTPUT SHOWN BELOW

OPTIONAL SH15: CHILLER ALARM INDICATOR

NOTICE
USE COPPER CONDUCTORS ONLY!
FAILURE TO USE COPPER CONDUCTORS COULD RESULT IN EQUIPMENT DAMAGE AS THE EQUIPMENT WAS NOT DESIGNED OR QUALIFIED TO ACCEPT OTHER TYPES OF CONDUCTORS.

AVIS
N'UTILISER QUE DES CONDUCTEURS EN CUIVRE!
L'UTILISATION DE MATÉRIAUX AUTRES QUE LE CUIVRE PEUT ENDOMMAGER L'ÉQUIPEMENT. CELUI-CI N'AYANT PAS ÉTÉ CONÇU OU HOMOLOGUÉ POUR ACCEPTER D'AUTRES TYPES DE CONDUCTEURS.

AVISO
¡UTILICE CONDUCTORES DE COBRE SOLAMENTE!
SI NO UTILIZA CONDUCTORES DE COBRE, EL EQUIPO PODRÁ SUFRIR DAÑOS. YA QUE NO HA SIDO DISEÑADO NI CALIFICADO PARA ACEPTAR OTROS TIPOS DE CONDUCTORES.

WARNING
HAZARDOUS VOLTAGE!
DISCONNECT ALL ELECTRIC POWER INCLUDING REMOTE DISCONNECTS AND FOLLOW LOCK OUT AND TAG PROCEDURES BEFORE SERVICING. INSURE THAT ALL MOTOR CAPACITORS HAVE DISCHARGED STORED VOLTAGE. UNITS WITH VARIABLE SPEED DRIVE, REFER TO DRIVE INSTRUCTIONS FOR CAPACITOR DISCHARGE. FAILURE TO DO THE ABOVE COULD RESULT IN DEATH OR SERIOUS INJURY.

AVERTISSEMENT
TENSION DANGEREUSE!
COUPER TOUTES LES TENSIONS ET OUVRIER LES SECTIONNEURS A DISTANCE, PUIS SUIVRE LES PROCEDURES DE VERROUILLAGE ET DES ETIQUETTES AVANT TOUTE INTERVENTION. VERIFIER QUE TOUTS LES CONDENSATEURS DES MOTEURS SONT DECHARGES. DANS LE CAS D'UNITS COMPORTANT DES ENTRAÎNEMENTS A VITESSE VARIABLE, SE REPORTER AUX INSTRUCTIONS DE L'ENTRAÎNEMENT POUR DECHARGER LES CONDENSATEURS. UN MANQUEMENT A LA PROCEDURE CRESSUS PEUT ENTRAÎNER DES BLESSURES GRAVES, VOIRE LA MORT.

ADVERTENCIA
VOLTAJE PELIGROSO!
DESCONECTE TODA LA ENERGIA ELECTRICA, INCLUIDO LAS DESCONECCIONES REMOTAS Y SIGA LOS PROCEDIMIENTOS DE CIERRE Y ETIQUETADO ANTES DE PROCEDER AL SERVICIO. ASEGURESE DE QUE TODOS LOS CAPACITORES DEL MOTOR HAYAN DESCARGADO EL VOLTAJE ALMACENADO. PARA LAS UNIDADES CON TRANSMISION DE VELOCIDAD VARIABLE, CONSULTE LAS INSTRUCCIONES PARA LA DESCARGA DEL CONDENSADOR. CRESSUS PUEDE ENTRAÑER LA MUERTE O LESIONES GRAVES.

Table 19. Unit control panel wiring 120 Vac

Standard Control Circuits: Unit Control Panel Control Wiring (120 Vac)	Unit Control Terminations	Input or Output Type	Contacts
Evaporator Water Flow Switch	1K11-J3-1 to 2	Binary Input	Normally Open, Closure with Flow
Condenser Water Flow Switch	1K11-J2-1 to 2	Binary Input	Normally Open, Closure with Flow
Evaporator Water Pump Control	1K12-J2-4 to 6	Binary Output	Normally Open
Condenser Water Pump Control	1K12-J2-1 to 3	Binary Output	Normally Open
Optional Control Circuits (120 Vac)	Note: Defaults are factory programmed; alternates can be selected at start-up using the service tool.		
Maximum Capacity Relay Output	1K14-J2-4	Binary Output	Normally Open
Head Relief Request Relay Output	1K14-J2-4 to 6	Binary Output	Normally Open
Ice Building Indicator	1K15-J2-1 to 3	Binary Output	Normally Open
Standard Low Voltage Circuits (Less than 30 Vac)^(a)	Unit Control Panel Terminations	Input or Output Type	Contacts
External Auto Stop Input	1K4-J2-1 to 2	Binary Input	Closure Required for Normal Operation
Emergency Stop Input	1K4-J2-3 to 4	Binary Input	Closure Required for Normal Operation
Optional Low Voltage Circuits			
External Base Loading Enable Input	1K9-J2-1 to 2	Binary Input	Normally Open
External Hot Water Control Enable Input	1K9-J2-3 to 4	Binary Input	Normally Open
External Ice Machine Control Enable Input	1K3-J2-1 to 2	Binary Input	Normally Open
Condenser Refrigerant Pressure	1K7-J2-4 to 6	Analog Output	2–10 Vdc
Chiller % Capacity Output	1K7-J2-1 to 3	Analog Output	2–10 Vdc
Evaporator/Condenser Differential Pressure Output	1K7-J2-4 to 6	Analog Output	2–10 Vdc
External Demand Limit Setpoint Input	1K6-J2-2 to 3	Analog Input	2–10 Vdc, or 4–20 mA
External Chilled Water Setpoint Input	1K6-J2-5 to 6	Analog Input	2–10 Vdc, or 4–20 mA
External Base Loading Setpoint Input	1K8-J2-2 to 3	Analog Input	2–10 Vdc, or 4–20 mA
Generic Refrigerant Monitor Input	1K8-J2-5 to 6	Analog Input	2–10 Vdc, or 4–20 mA
Outdoor Air Temperature Sensor	Inter-processor Communication (IPC) Bus Connection and Sensor—4BT9	Communication and Sensor	
LON Interface	1K25	Communication to Tracer or LonTalk	(As Ordered; See Sales Order)
BACnet or MODBUS	1K20–P1	Communication to BACnet or MODBUS	(As Ordered; See Sales Order)
Air-Fi®	4K4	Wireless Communication to Tracer	

Note: All wiring to be in accordance with National Electrical Code (NEC) and any local codes.

^(a) Standard low-voltage circuits (less than 30 Vac) must be separated from 120 Vac or higher wiring.

Sensor Circuits

All sensors are factory-installed except the optional outdoor air temperature sensor, and Wireless modules (refer to the following figure for sensor locations). This sensor is required for the outdoor air temperature type of chilled

water reset. Use the following guidelines to locate and mount the outdoor air temperature sensor. Mount the sensor probe where needed; however, mount the sensor module in the control panel.

Figure 27. Agility chiller sensor locations

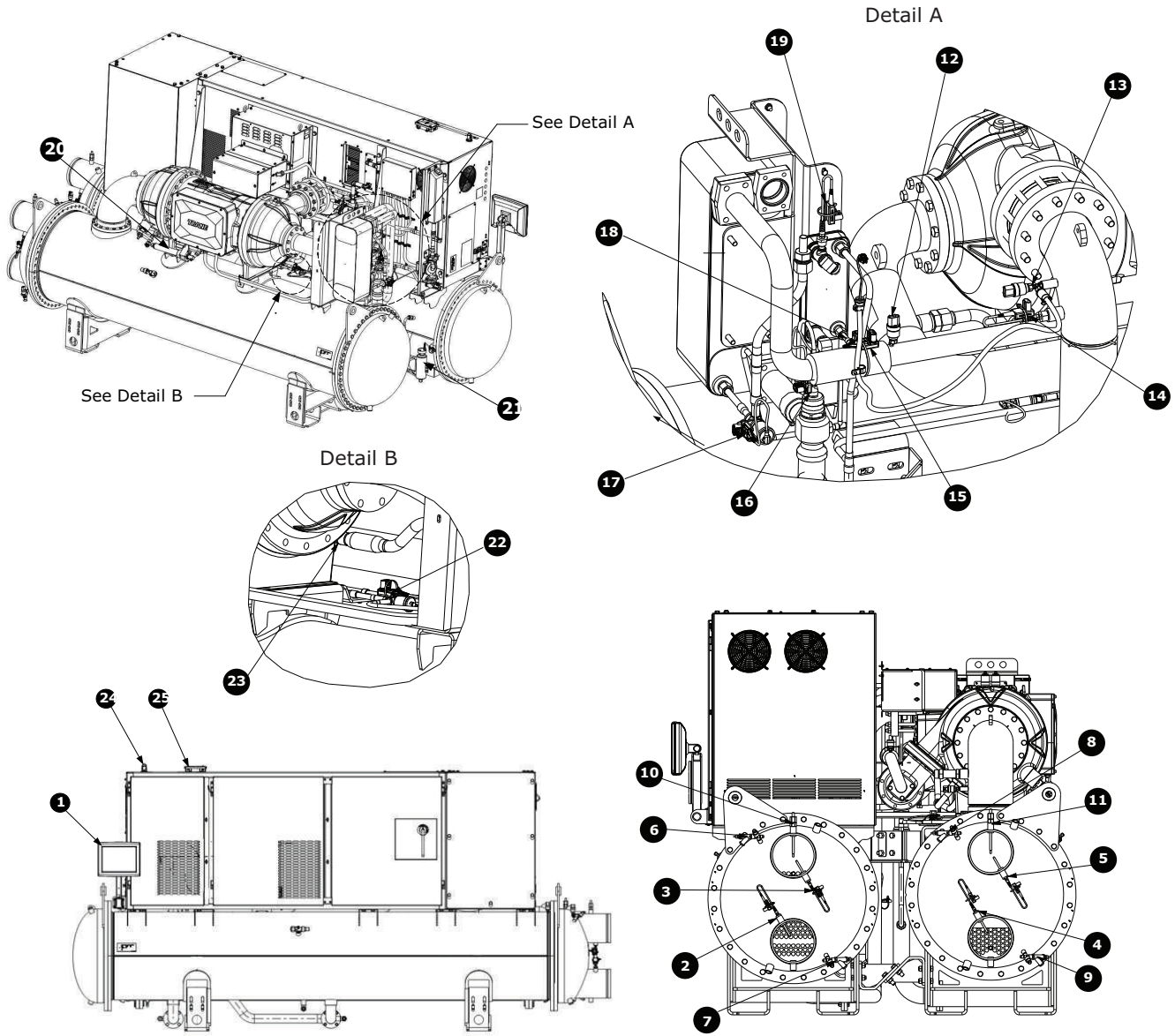

- 1. 4P1, Tracer® AdaptiView™ display
- 2. 4BT3, Condenser entering water temperature
- 3. 4BT6, Condenser leaving water temperature
- 4. 4BT2, Evaporator entering water temperature
- 5. 4BT5, Evaporator leaving water temperature
- 6. 4BP7, Condenser leaving water pressure transducer (Low)
- 7. 4BP6, Condenser entering water pressure transducer (High)
- 8. 4BP5, Evaporator leaving water pressure transducer (Low)
- 9. 4BP4, Evaporator entering water pressure transducer (High)
- 10. 4R18, Condenser water flow detector
- 11. 4R17, Evaporator water flow detector
- 12. 4BP3, Economizer leaving pressure

13. **4BP2**, Condenser pressure
14. **4BT7**, Compressor discharge temperature
15. **4BT8**, Economizer leaving refrigerant temperature
16. **4M2**, Evaporator EXV
17. **4M4**, Economizer EXV
18. **4M6**, Drive cooling EXV
19. **4BT4**, Drive cooling supply temperature
20. **4M5**, Inlet guide vane second stage actuator
21. **4B1**, Condenser liquid level
22. **4M3**, Motor bearing control cooling EXV
23. **4M8**, Motor cooling EXV
24. **4Y1**, Wi-Fi antenna
25. **4K4**, Air-Fi® antenna

Optional Control and Output Circuits

Install various optional wiring as required by the owner's specifications (refer to "System Control Circuit Wiring (Field Wiring)," p. 38).

Schematic Wiring Drawings

Please refer to the submittals and drawings that shipped with the unit. Additional wiring drawings for Agility™ chillers are available from your local Trane office.

Adaptive Frequency Drive

The Trane TR200 Adaptive Frequency™ Drive (AFD) is an electronic motor controller that converts alternating current (AC) mains input into a variable AC waveform output. The frequency and voltage of the output are regulated to control the motor speed or torque. The TR200 drive includes the following features:

- Soft start to minimize inrush current
- Improved harmonic mitigation with direct current (DC) link reactor
- Integrated power fuse
- Graphical liquid-crystal display (LCD) keypad
- Unit-mounted with factory pre-wiring
- "Trane Drive Utility" for configuration and tracking

Programming

NOTICE

Equipment Damage!

Changing default clockwise phase rotation or enabling phase reversal protection could prevent proper chiller operation or cause equipment damage.

- **Do NOT change Adaptive Frequency™ drive (AFD) phase rotation to counterclockwise.**
- **Do NOT enable phase reversal protection.**

Field replacement drives must be programmed via the keypad interface. Contact your local Trane Service Agency for assistance.

Building Automation Systems

BACnet Building Automation Control Network

The BACnet® control network for Symbio™ 800 expands communications from the unit controls network to the Tracer® Ensemble™ or Tracer® SC+ building automation system (BAS) or third party building automation system. Utilizing BACnet, the BAS allows external setpoint and configuration adjustment and monitoring of status and diagnostics. The Symbio 800 utilizes the BACnet defined TP protocol as defined in ASHRAE standard 135-2004. This controller works in standalone mode, with Tracer Ensemble, Tracer SC+ or when connected to a third party building automation system that supports BACnet.

Modbus Automation Control Network

Allows the user to easily interface with Modbus® RTU communication protocol via a single twisted pair wiring or Modbus® TCP over Ethernet from the Symbio™ 800 controller to a factory installed device.

LonTalk Building Automation Systems

The LonTalk® communication protocol for the Symbio™ 800 controller expands communications from the unit controls network to a Tracer® Ensemble™ building automation system or third party building automation system. Utilizing LonTalk, the BAS allows external setpoint and configuration adjustment and monitoring of status and diagnostics. The Symbio 800 utilizes an FTT-10A free topology transceiver, which supports non-polarity sensitive, free topology wiring—which in turn allows the system installer to utilize star, bus, and loop architectures. This controller works in standalone mode, peer-to-peer with one or more other units, or when connected to a Tracer



Electrical Requirements

Ensemble, Tracer SC+, or a third party building automation system that supports LonTalk.



Installation: Controls

Overview

Agility™ model HDWA units utilize the following control/interface components:

- Symbio 800 Controller
- Tracer AdaptiView™ TD12 Operator Interface. For information about the Tracer® AdaptiView™ display, which is used to interface with the internal chiller data and functions provided by the Symbio™ 800, refer to *Tracer AdaptiView Display for Water-cooled Agility Chillers Operations Guide* (HDWA-SVU001*-EN)

Symbio™ 800

The Symbio™ 800 controller is a factory-installed, application specific and programmable controller designed to control chillers and large packaged HVAC equipment. A 12 inch user interface features a touch-sensitive color screen that provides facility managers at-a-glance operating status, performance monitoring, scheduling changes, and operating adjustments. Other advanced features include automated controller back-up, and optional features such as secure remote connectivity, wireless building communications, mobile device connectivity, and custom programming with an expandable I/O.

For more information, see *Installation, Operation, and Maintenance manual, BAS-SVX080*-EN, Symbio™ 800 Controller*.

AdaptiView™ Display

Information is tailored to operators, service technicians, and owners. When operating a chiller, specific information is needed on a day-to-day basis—setpoints, limits, diagnostic information, and reports. This information is provided through the AdaptiView™ display. Logically organized groups of information—chiller modes of operation, active diagnostics, settings and reports put information conveniently at your fingertips.

For more information, see *Agility Water-Cooled Chillers AdaptiView™ Display with Symbio™ Controls User Guide* (HDWA-SVU002*-EN).

Tracer TU

The AdaptiView™ TD12 operator interface allows for daily operational tasks and setpoint changes. However, to adequately service chillers, Tracer® TU service tool is required. (Non-Trane personnel, contact your local Trane office for software purchase information.) Tracer TU adds a level of sophistication that improves service technician effectiveness and minimizes chiller downtime. This portable PC-based service-tool software supports service and maintenance tasks, and is required for software upgrades, configuration changes and major service tasks.

Tracer TU serves as a common interface to all Trane chillers, and will customize itself based on the properties of the chiller with which it is communicating. Thus, the service technician learns only one service interface.

The panel bus is easy to troubleshoot using LED sensor verification. Only the defective device is replaced. Tracer TU can communicate with individual devices or groups of devices.

All chiller status, machine configuration settings, customizable limits, and up to 100 active or historic diagnostics are displayed through the service-tool software interface.

LEDs and their respective Tracer TU indicators visually confirm the availability of each connected sensor, relay, and actuator.

Tracer TU is designed to run on a customer's laptop, connected to the Tracer® Symbio™ 800 control panel with a USB cable. Your laptop must meet the following hardware and software requirements:

- 1 GB RAM (minimum)
- 1024 x 768 screen resolution
- CD-ROM drive
- Ethernet 10/100 LAN card
- An available USB 2.0 port
- Windows 7 Enterprise or Professional operating system (32-bit or 64-bit)

Note: *Tracer TU versions 8.6 and earlier will also support Microsoft® Windows® XP Professional operation system with Service Pack 3 (SP3) .*

- Microsoft .NET Framework 4.0 or later

Notes:

- *Tracer TU is designed and validated for this minimum laptop configuration. Any variation from this configuration may have different results. Therefore, support for Tracer TU is limited to only those laptops with the configuration previously specified.*
- *For more information, see TTU-SVN01*-EN Tracer TU Getting Started Guide.*

Integrated Rapid Restart

Chiller controls are designed and engineered for Rapid Restart™. In the event of a power interruption, the chiller will start a compressor before the front panel display is fully powered up, eliminating the need for an uninterrupted power supply (UPS). Advanced features and functionality are built into the chillers. Bringing a chiller back online rapidly after a loss of power is critical to operations in mission critical environments, which demand the highest levels of reliability.



Installation: Controls

Under optimal conditions, it can restart in as little as 45 seconds with no need for uninterrupted power supply

(UPS). An 80 percent cooling load can be achieved in less than 2.5 minutes after power restoration.

AdaptiView Control Panel

Figure 28. Control panel: Tracer AdaptiView main unit assembly (showing low voltage areas for proper routing of field wiring)

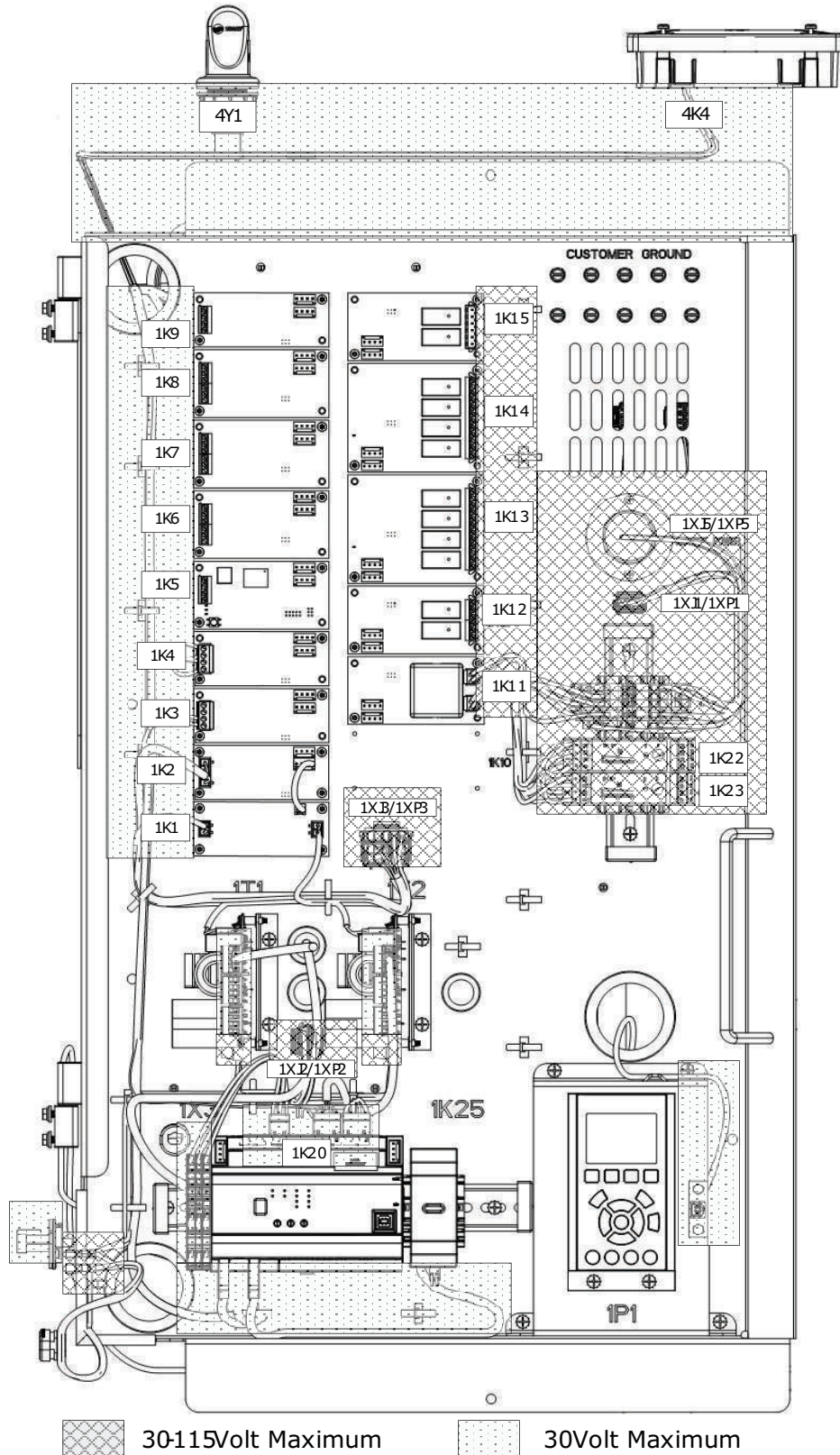

Installing the Tracer AdaptiView Display

During shipment, the Tracer® AdaptiView™ and support arm are boxed, shrink-wrapped, and shipped with unit. The display and support arm must be installed at the site.

Important: For best results, Trane, or an agent of Trane, must install the Tracer AdaptiView display and support arm.

1. Unwrap the chiller. Locate the box containing the Tracer AdaptiView display and support arm strapped to the shear plate between the condenser and the evaporator (see the following figure).

2. Remove the display and support arm from the box.

Note: Display to support arm screws are M4 (metric size 4), 6 to 8 mm long, and are shipped with the display. Display arm screws are M6 (metric size 6), 16 mm long, washers, and nuts used to secure arm to unit bracket are shipped in the parts box.

3. Using the M6 hardware shipped in the parts box, attach the display support arm to the mounting bracket on the side of the control panel (labeled A and B in the following figure).
4. Plug the power cable (labeled C in the following figure) and the Ethernet cable (labeled D in the following figure) into the bottom of the display. Plug other ends of the cables into the ports on the side of the control panel.
5. Adjust the Tracer AdaptiView display support arm so the base plate that attaches to the display is horizontal.

⚠ CAUTION

Tension in Display Support Arm!

Failure to follow instructions below could result in unexpected movement of the spring-loaded support arm which could result in minor to moderate injury.

Ensure that the support arm is in the full upright position when removing the Tracer AdaptiView display from the support arm.

Note: Review “Adjusting the Tracer® AdaptiView™ Display Arm,” p. 47 before attaching the display as some adjustments may be required prior to attaching the display to the support arm base.

6. Position the Tracer AdaptiView display—with the LCD screen facing up—on top of the display support arm base plate.

Note: Ensure the Trane logo is positioned so that it will be at the top when the display is attached to the display support arm.

Important: Use care when positioning the Tracer AdaptiView display on top of the support arm base plate and do NOT drop the display.

7. Align the four holes in the display with the screw holes in the display support arm base plate.
8. Attach the Tracer AdaptiView display to the display support arm base plate (labeled E in the following figure) using the M4 (metric size 4) screws referenced in step 3.

Figure 29. Display arm installation

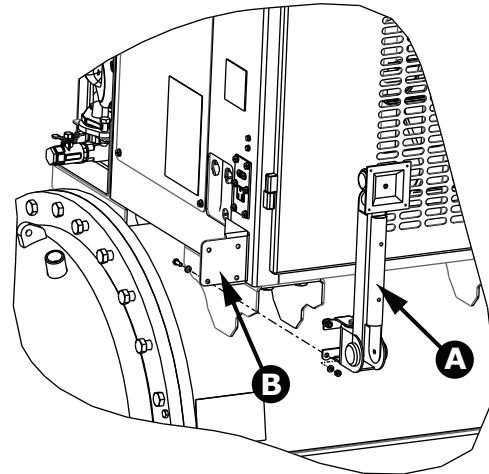

Figure 30. Power cable and Ethernet cable connections

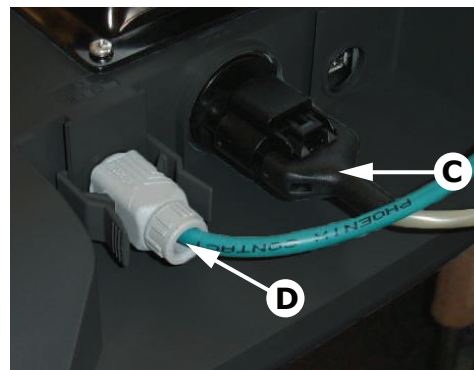
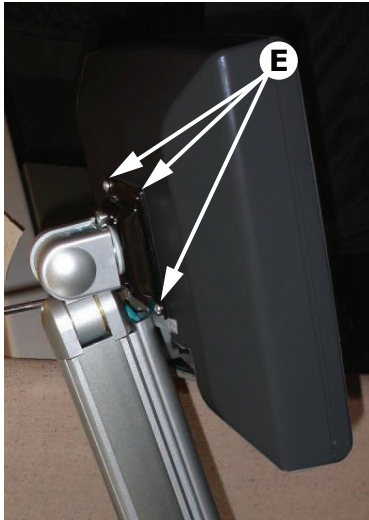

Figure 31. Display attachments to the support arm base plate



Adjusting the Tracer[®] AdaptiView[™] Display Arm

The Tracer[®] AdaptiView[™] display arm may become too loose or too tight and may need adjustment. There are three joints on the display arm that allow the display to be positioned at a variety of heights and angles (refer to items labeled 1, 2, and 3 in the following figure).

Figure 32. Joint locations on the display arm

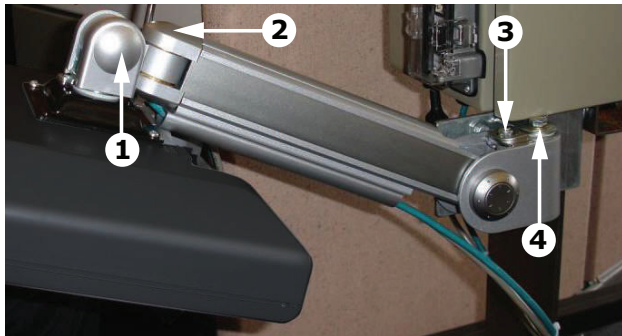

To adjust the tension on the display arm:

- At each joint in the display arm, there is either a hex bolt (1 and 2) or hex screw (3). Turn the hex bolt or screw in the proper direction to increase or decrease tension.

Note: Each hex bolt or screw is labeled with *loosen/tighten* or +/- indicators.
- Joint 3 has a 6 mm hex screw controlling the tension on a gas spring, which allows the Tracer[®] AdaptiView[™] display to tilt up and down.
- Joints 1 and 2 are covered by a plastic cap. Remove the plastic cap to access the screw. Adjust using a 13 mm wrench as necessary.
- To adjust the swivel rotation tension of the Tracer[®] AdaptiView[™] display, adjust the screw located in the support arm base plate, as described in the final step in the Installing the Tracer[®] AdaptiView[™] Display section.. *This adjustment must be done prior to attaching the display to the support arm base.* Use a 14 mm wrench to adjust the tension.
- To adjust the left/right swivel of the entire display arm, use a 13 mm wrench to adjust the screw labeled 4 in the preceding figure.

Module Installation

Air-Fi[®]

For installation instructions, see BAS-SVN038*-EN, *Air-Fi[®] Wireless Communications Interface (WCI) Installation Instructions*.



Installation: Controls

Wi-Fi

For installation instructions, see BAS-SVN042*-EN, *Trane® Wi-Fi Module Installation Instructions*.



Operating Principles

General Requirements

Operation and maintenance information are covered in this section. By carefully reviewing this information and following the instructions given, the owner or operator can successfully operate and maintain the chiller. If mechanical problems do occur, however, contact a Trane service technician to ensure proper diagnosis and repair of the unit.

Important:

- Although Agility™ chillers can operate through surge, it is NOT recommended to operate them through repeated surges over long durations. If repeated surges of long durations occur, contact your Trane Service Agency to resolve the issue.
- Agility™ are selected, designed, and built for a particular set of design conditions. Operation outside of design conditions may result in improper operation. Refer to chiller selection for minimum unloading.

Refrigeration Cycle

When in the cooling mode, liquid refrigerant is distributed along the length of the evaporator and sprayed through small holes in a distributor (i.e., running the entire length of the shell) to uniformly coat each evaporator tube. Here, the liquid refrigerant absorbs enough heat from the system water circulating through the evaporator tubes to vaporize. The gaseous refrigerant is then drawn through the suction connection and the first-stage variable inlet guide vanes, and into the first-stage impeller.

The unit is equipped with a semi-hermetic, direct-drive, two-stage, centrifugal compressor that includes inlet guide vanes for capacity control. The Adaptive Frequency™ Drive (AFD) provides capacity control with lower speeds. Compressed gas from the first-stage impeller is discharged through the interstage pipe to the second-stage impeller. Here, the refrigerant gas is again compressed, and then discharged into the condenser. Baffles within the condenser shell distribute the compressed refrigerant gas evenly across the condenser tube bundle. Water circulated through the condenser tubes absorbs heat from the refrigerant, causing the refrigerant to condense. The subcooled liquid refrigerant then flows out of the bottom of the condenser.

The liquid refrigerant is then split such that the primary flow is directed through one side of the brazed plate heat exchanger economizer, while a significantly smaller portion of the flow passes through an expansion valve, lowering refrigerant pressure and temperature before entering the secondary side of the BPHE as two-phase refrigerant. The heat transfer between the primary and secondary channels in the BPHE results in further subcooling of the primary liquid as it rejects heat to, and consequently superheats,

the secondary flow. The additional subcooling of the liquid prior to expansion through the main electronically-controlled valve effectively increases the overall capacity of the evaporator. In addition, the superheated vapor bypasses the evaporator and first stage of compression (the secondary BPHE flow is added prior to the second stage of compression).

Figure 33. Refrigerant flow

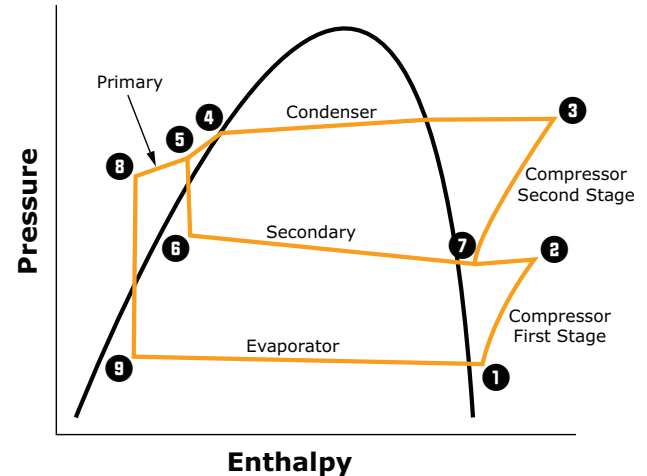

Compressor Motor

Two magnetic bearing modules levitate and align the rotating assembly. The motor is permanent magnet type and is cooled by refrigerant gas sourced from the interstage pipe, metered through an orifice or electronic expansion valve, and routed through the bearing modules and motor windings.

Adaptive Frequency Drive

An Adaptive Frequency™ Drive (AFD) and control panel is provided on every chiller. Microprocessor-based unit control modules (Symbio™ 800) provide for accurate chilled water control as well as monitoring, protection, and adaptive limit functions. The "adaptive" nature of the controls intelligently prevents the chiller from operating outside of its limits, or compensates for unusual operating conditions, while keeping the chiller running rather than simply tripping due to a safety concern. When problems do occur, diagnostic messages assist the operator in troubleshooting.

Uninterruptible Power Supply

Agility™ chillers contain an on-line double-conversion Uninterruptible Power Supply (UPS) to ensure that the compressor's magnetic bearing system continues to function in the event of a power failure. The UPS (2T5) provides power to the Symbio™ 800 controls for 90



Operating Principles

seconds while the compressor coasts to a stop. When line power fails, power is supplied to the UPS with an internal battery.

When power is removed, or if the chiller's disconnect switch is turned off, the UPS will supply power to the Symbio™ 800 controls for 90 seconds and then the UPS will de-activate. The UPS's internal battery is not completely discharged so that when power is restored, the battery can provide enough power for additional shutdowns.

The UPS has a fault indicator that is wired to a Symbio™ 800 controls Low Level Intelligent Device (LLID; 1K3). If the UPS indicates a fault, an immediate shutdown diagnostic will be announced on the Symbio™ 800 controls.

The following UPS issues could cause this diagnostic:

- Clary (first generation UPS)
 - EPO Protection
 - Busbar Voltage Fault
 - IGBT Over-Temperature
 - Fan Fault
 - Battery Fault
 - Output Fault
 - Multiple Inverting Fault
- N1C (second generation UPS)
 - Emergency Protection
 - Busbar Voltage Fault
 - Over-Temperature
 - Output Fault
 - Output Overload
 - Fan Fault
 - Battery Fault
 - Battery Voltage Too High
 - Low Battery

Evaporator and Condenser

Heat exchangers are shell and tube design. Standard tubes are externally finned, internally enhanced seamless copper with lands at all tube sheets. All tube sheets are made of carbon steel. Tubes are mechanically expanded into tube sheets and mechanically fastened to tube

supports. Evaporator and condenser tubes are 0.75-in. (19.05-mm) diameter. All tubes can be individually replaced.

Shells are carbon steel plate. The evaporator is designed, tested, and stamped in accordance with ASME Code for refrigerant-side/working-side pressure of 200 psig (1379.0 kPaG). The condenser is designed, tested, and stamped in accordance with ASME Code for refrigerant-side/ working-side pressure of 300 psig (2068.4 kPaG).

All water pass arrangements are available with grooved connections (150 psig [1034.2 kPaG] waterside working pressure). All connections may be either right- or left-handed. Waterside shall be hydrostatically tested at 1.5X design working pressure.

Drive Cooling System

The drive cooling system rejects heat through a hybrid air and fluid heat sink. The Adaptive Frequency™ Drive (AFD) controls the fan speed to reject some of the heat while the refrigerant expansion valve modulates to maintain a fluid supply temperature to reject the remaining heat.

Drive cooling circuit includes a wet rotor circulation pump that circulates a secondary heat transfer fluid in a closed system through the AFD heat sinks, output load inductor and a brazed plate heat exchanger. The pump is fed from a thermal expansion tank with a vented-pressure cap which is also used as the circuit pressure relief. The circuit also includes a particulate strainer and a drain valve for servicing.

Tracer® AdaptiView™ Display

Information is tailored to operators, service technicians, and owners.

When operating a chiller, specific information is needed you needed on a day-to-day basis—setpoints, limits, diagnostic information, and reports.

Day-to-day operational information is presented at the display. Logically organized groups of information—chiller modes of operation, active diagnostics, settings, graphs, and reports put information conveniently at your fingertips. For more information, refer to *Tracer® AdaptiView™ Display for Water-cooled Agility Chillers Operations Guide* (HDWA-SVU001*-EN).

Start-up and Shutdown

Important: Initial unit commissioning start-up must be performed by Trane or an agent of Trane specifically authorized to perform start-up and warranty of Trane products. Contractor shall provide Trane (or an agent of Trane specifically authorized to perform start-up) with notice of the scheduled start-up at least two weeks prior to the scheduled start-up.

- The text in the circles is the internal software designations for each state.
- The first line of text in the circles is the visible top level operating modes that can be displayed in AdaptiView™.
- The shading of each software state circle corresponds to the shading on the time lines that show the chiller's state.

Sequence of Operation

Adaptive control algorithms are used on Agility™ chillers. This section illustrates common control sequences.

Software Operation Overview Diagram

The following figure is a diagram of the five possible software states. This diagram can be thought of as a state chart, with the arrows and arrow text, depicting the transitions between states:

There are five generic states that the software can be in:

- Power Up
- Stopped
- Starting
- Running
- Stopping

Figure 34. Software operation overview

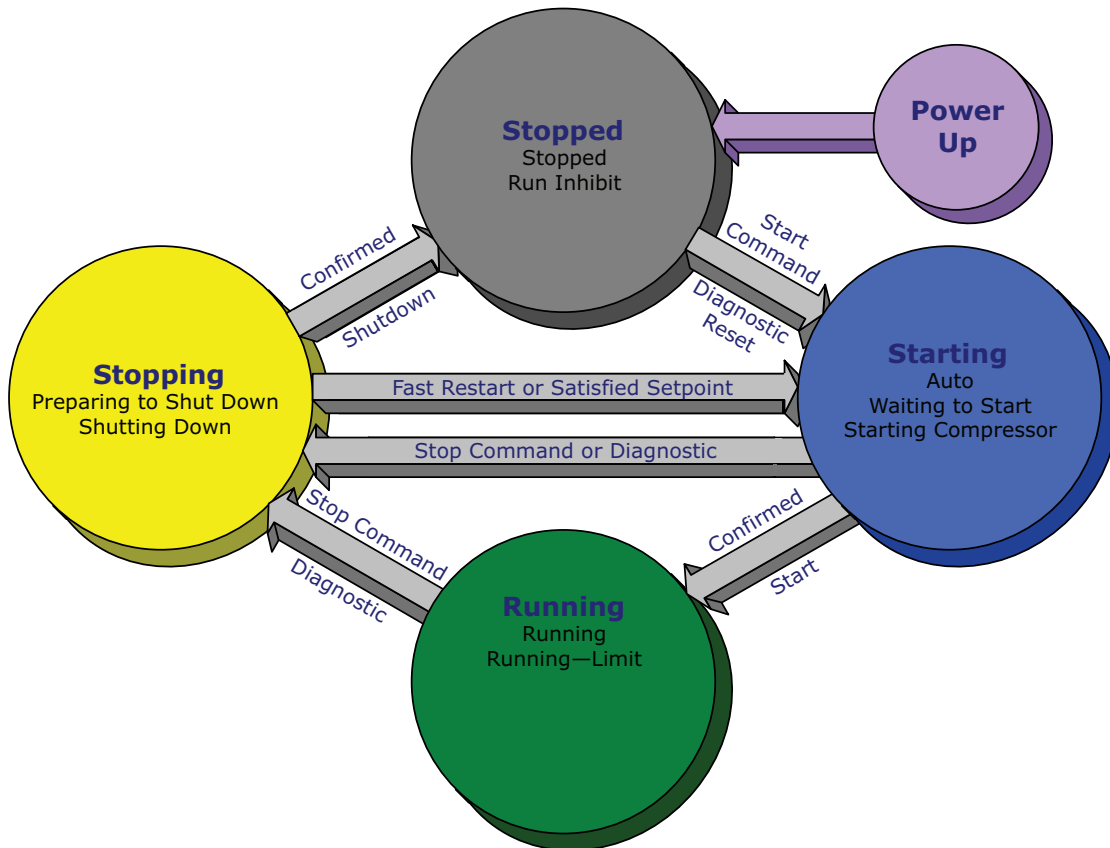
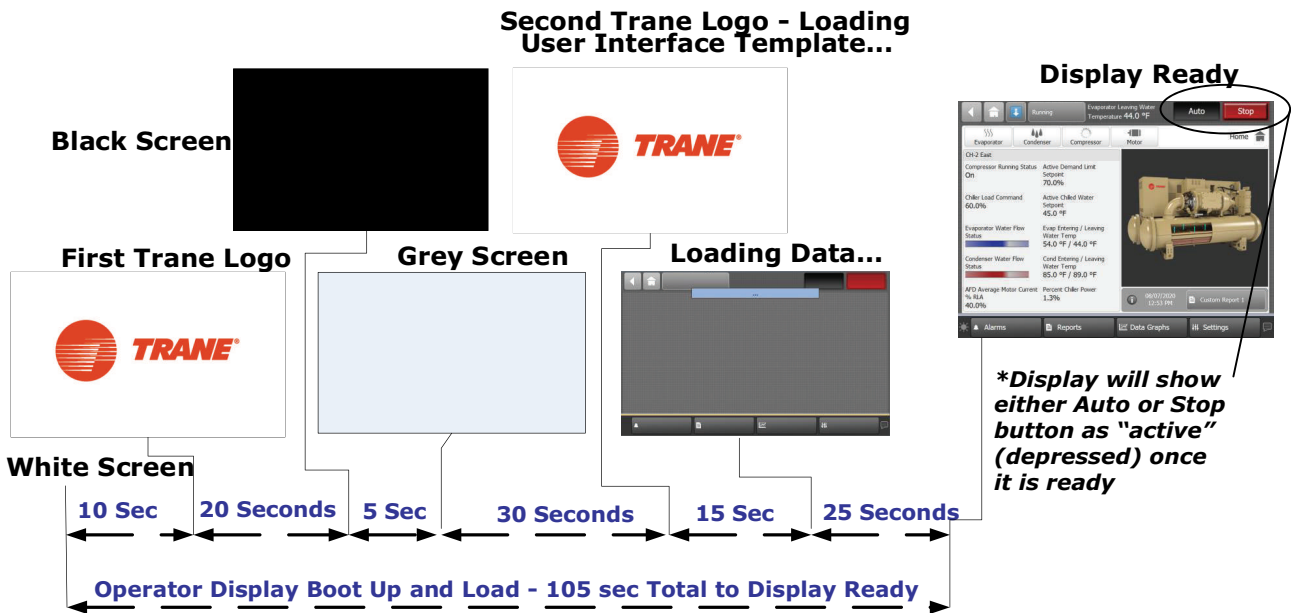

Figure 35. Sequence of operation: AdaptiView power up



In the following diagrams:

- The time line indicates the upper level operating mode, as it would be viewed in the Tracer® AdaptiView™.
- The shading color of the cylinder indicates the software state.
- Text in parentheses indicates sub-mode text as viewed in the Tracer® AdaptiView™.
- Text above the time line cylinder is used to illustrate inputs to the Symbio™ 800. This may include user input to the AdaptiView™ touch screen, control inputs from sensors, or control inputs from a generic BAS.
- Boxes indicate control actions such as turning on relays, or moving the inlet guide vanes.

- Smaller cylinders under the main cylinder indicate diagnostic checks.
- Text outside a box or cylinder indicates time-based functions.
- Solid double arrows indicate fixed timers.
- Dashed double arrows indicate variable timers.

Power Up

“Software Operation Overview Diagram,” p. 51 includes an illustration of Tracer® AdaptiView™ during a power up of the Symbio™ 800. This process takes from 30 to 50 seconds depending on the number of installed options.

Power Up to Starting

The following figure shows the timing from a power up event to energizing the compressor. The shortest allowable time would be under the following conditions:

- All temperatures below their starting limits

- Evaporator and condenser water flowing
- Power up start delay setpoint set to 0 minutes
- Need to cool

The above conditions would allow for a minimum power up to starting compressor time of 45 seconds.

Figure 36. Sequence of events: power up to starting

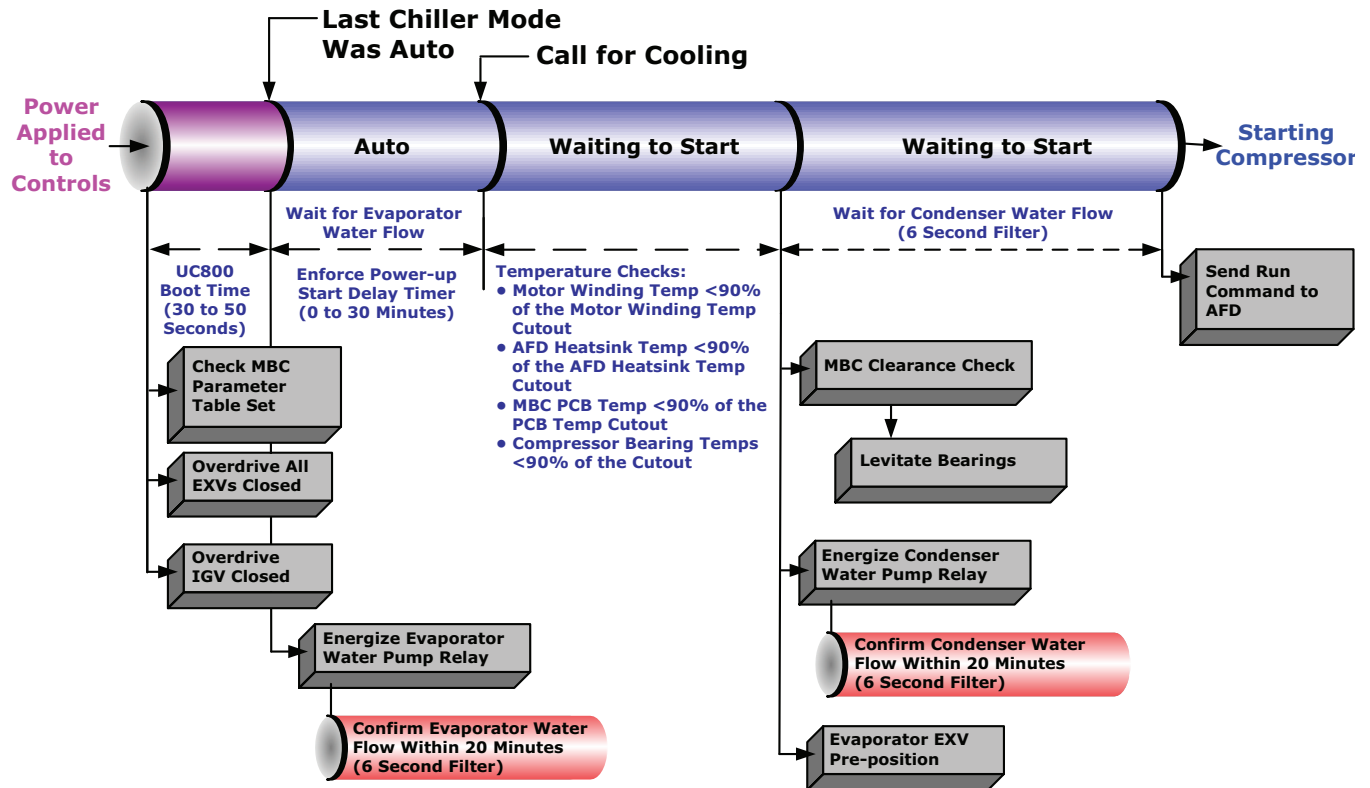

Start-up and Shutdown

Stopped to Starting — Cooling Mode

The stopped to starting diagram shows the timing from a stopped mode to energizing the compressor. The shortest allowable time would be under the following conditions:

- All temperatures below their starting limits
- Evaporator and condenser water flowing

- Power up start delay timer has expired
- Adjustable stop to start timer has expired
- Need to cool

The above conditions would allow the compressor to start in 45 seconds.

Figure 37. Sequence of events: stopped to starting

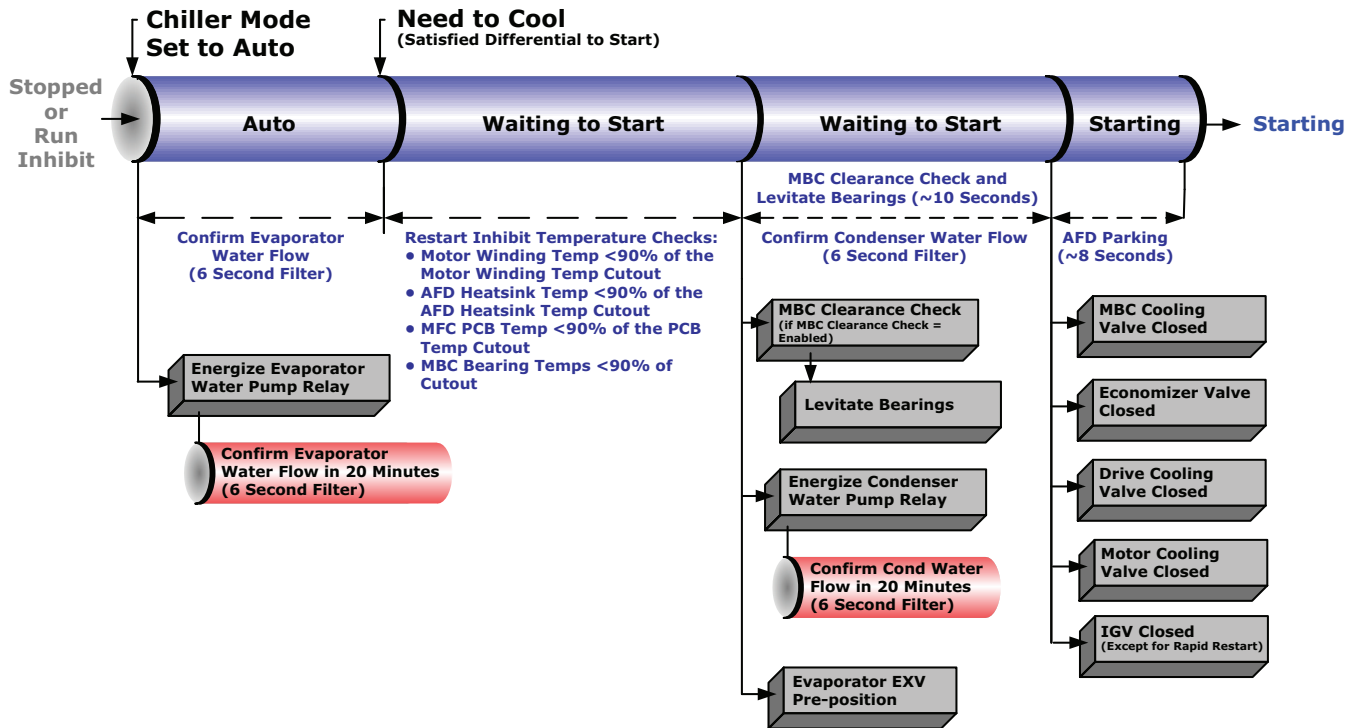

Stopped to Starting — Heating Mode

The stopped to starting diagram shows the timing from a stopped mode to energizing the compressor. The shortest allowable time would be under the following conditions:

- All temperatures below their starting limits
- Evaporator and condenser water flowing

- Power up start delay timer has expired
- Adjustable stop to start timer has expired
- Need to heat

The above conditions would allow the compressor to start in 45 seconds.

Figure 38. Sequence of events: stopped to starting — heating mode

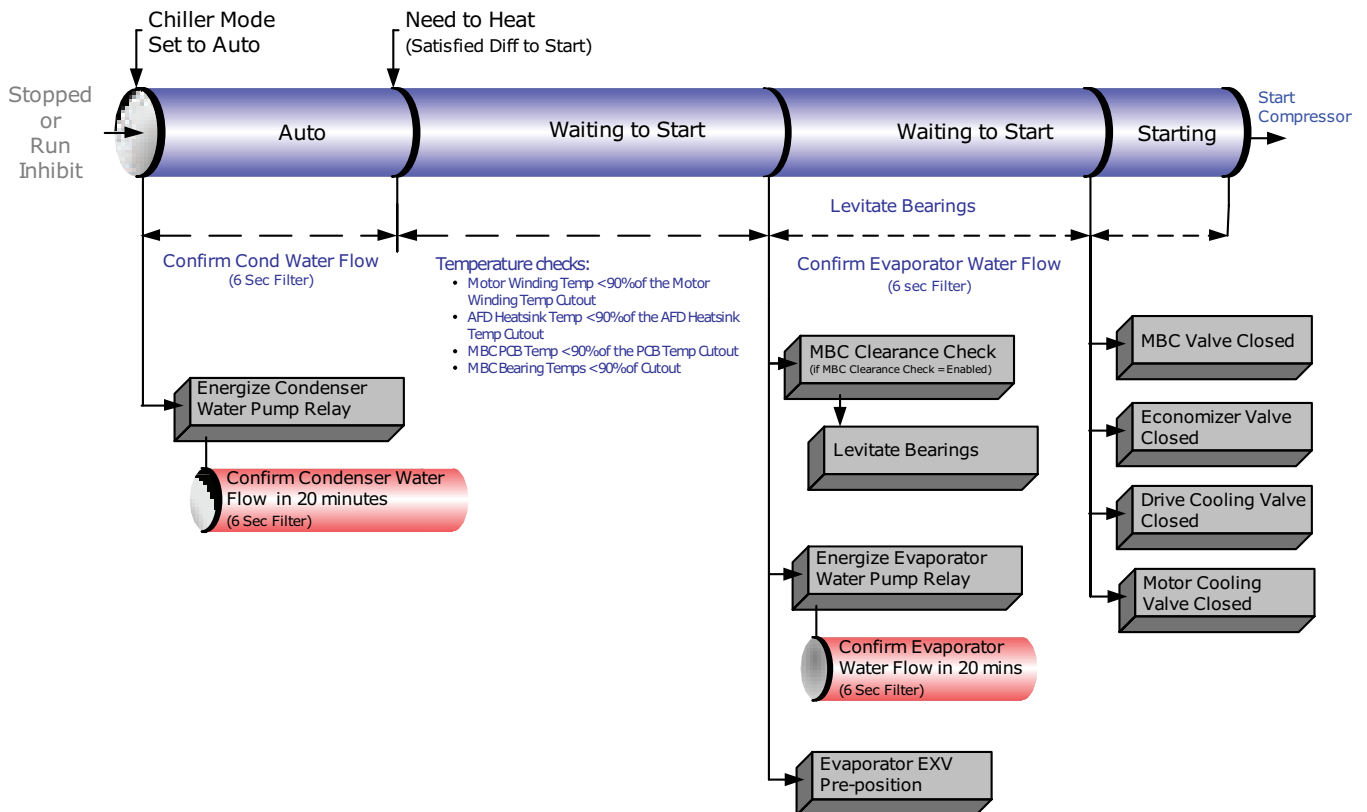

Running

The following figure shows a typical running sequence.

Figure 39. Sequence of events: running

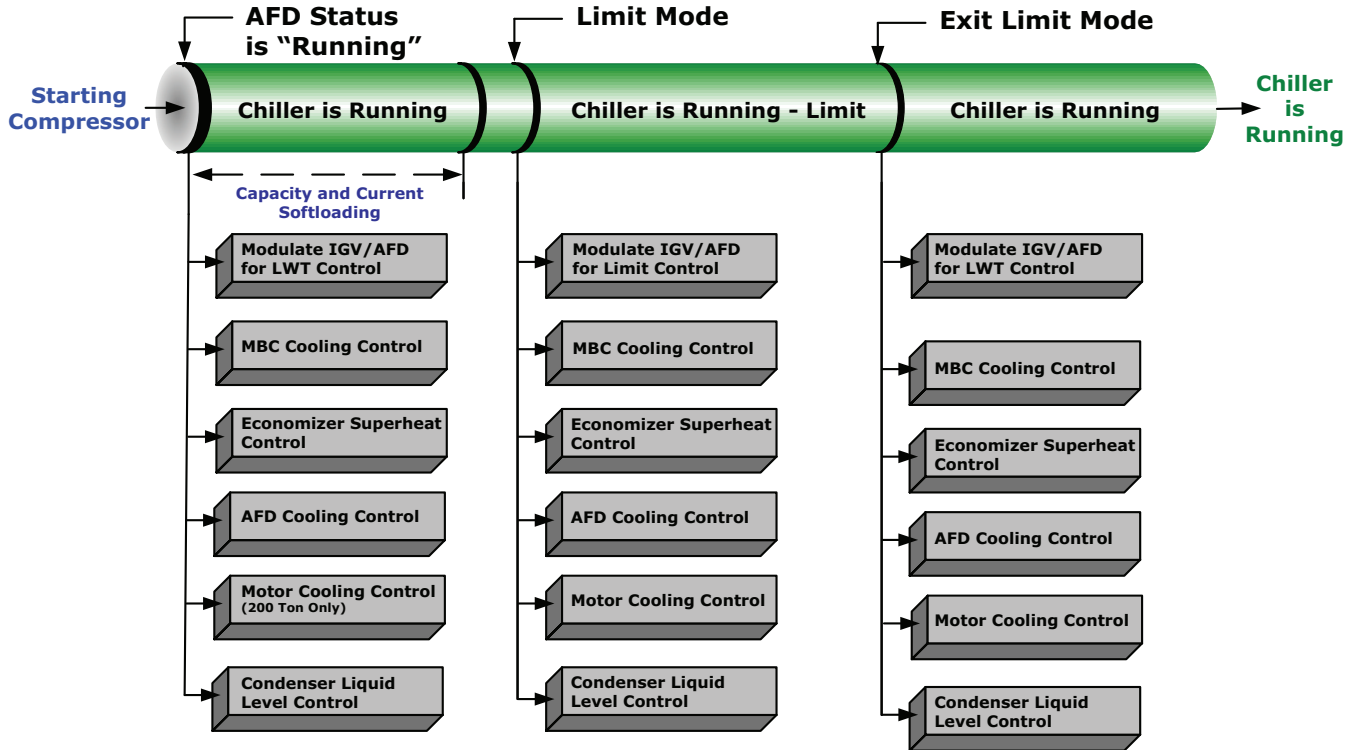

Satisfied Setpoint

The following figure shows the normal transition from running to shutting down due to the evaporator leaving

water temperature falling below the differential to stop setpoint.

Figure 40. Sequence of events: satisfied setpoint

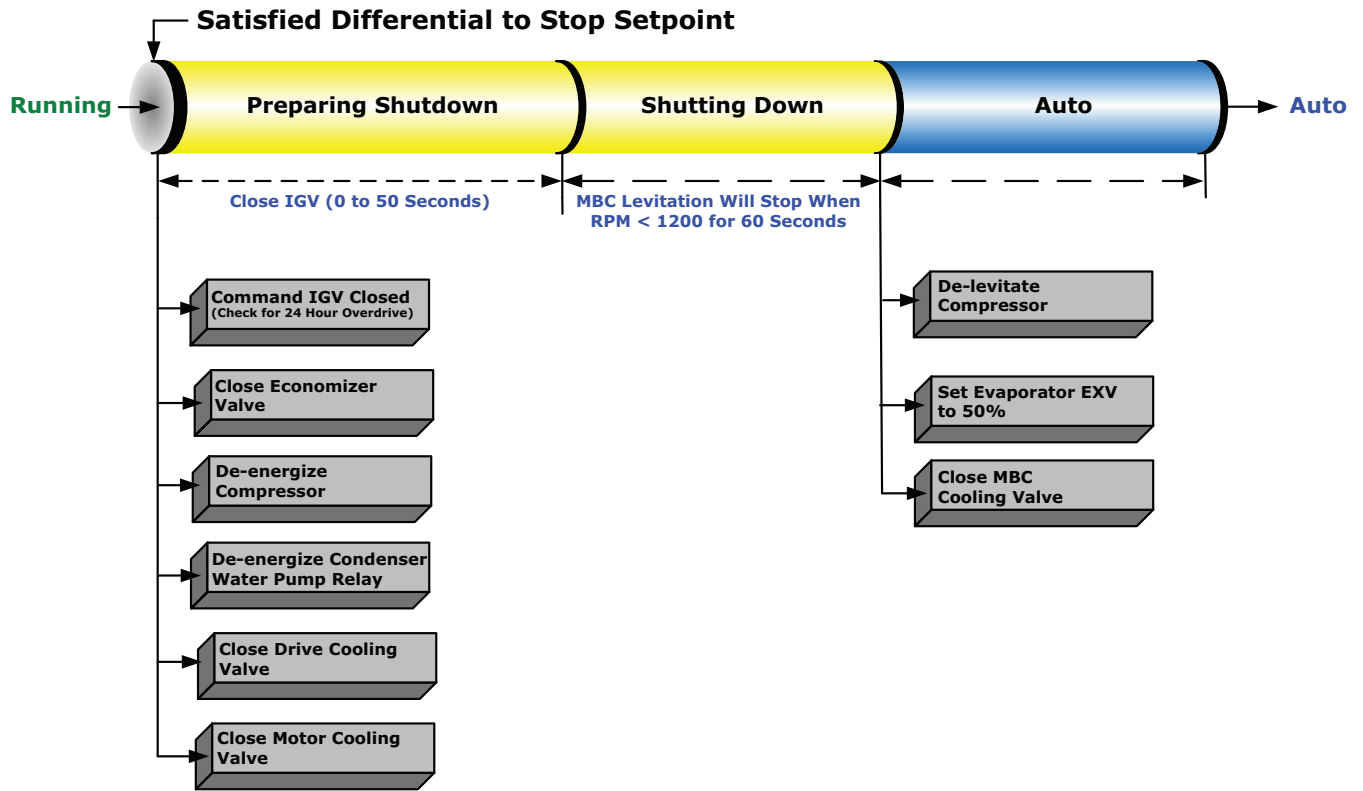

Normal Shutdown to Stopped or Run Inhibit

the top indicate the final mode if the stop is entered via various inputs.

The following figure shows the transition from running through a normal (friendly) shutdown. The dashed lines on

Figure 41. Sequence of events: normal shutdown to stopped or run inhibit

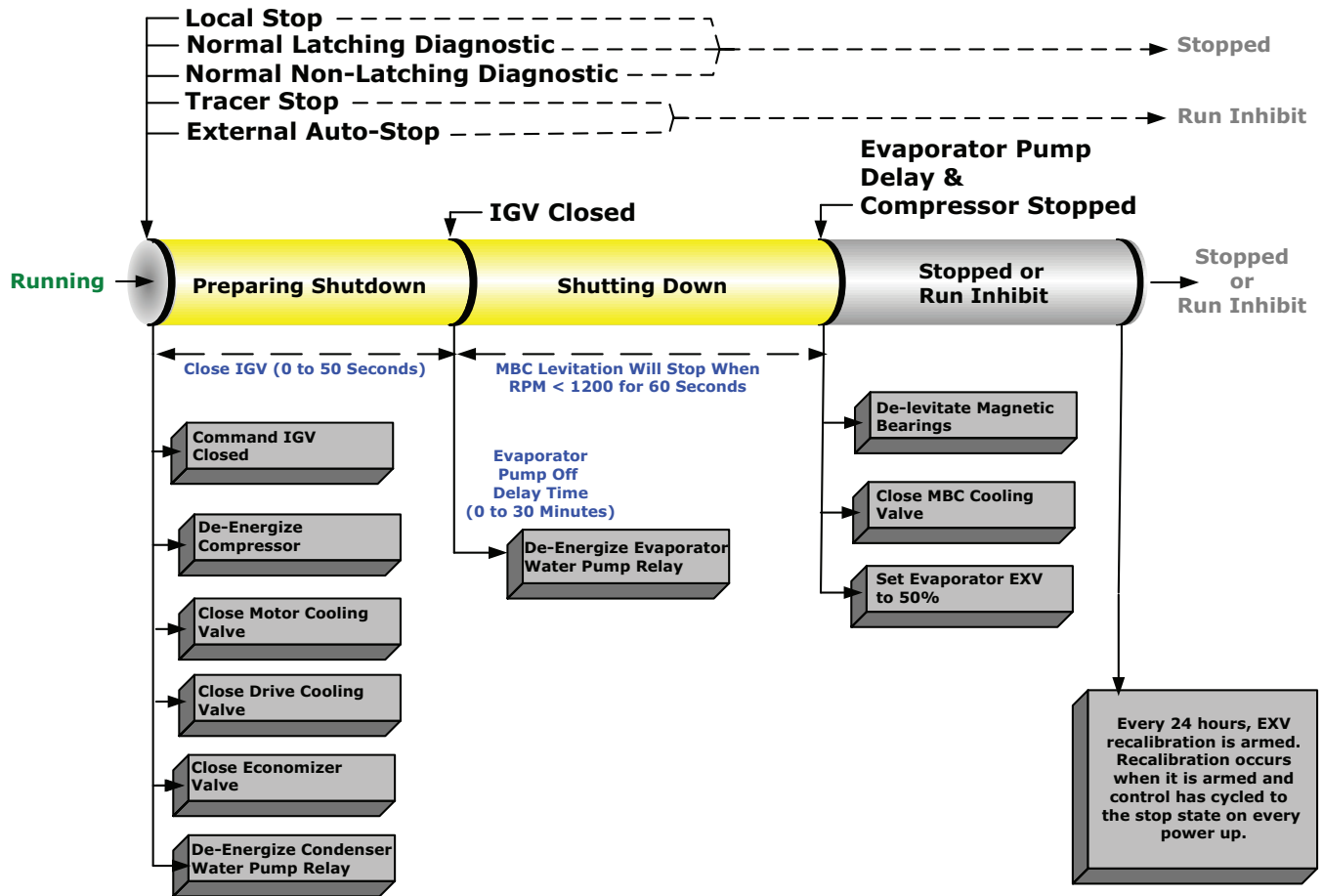

Immediate Shutdown to Stopped or Run Inhibit

top indicate the final mode if the stop is entered via various inputs.

The following figure shows the transition from running through an immediate shutdown. The dashed lines on the

Figure 42. Sequence of events: immediate shutdown to stopped or run inhibit

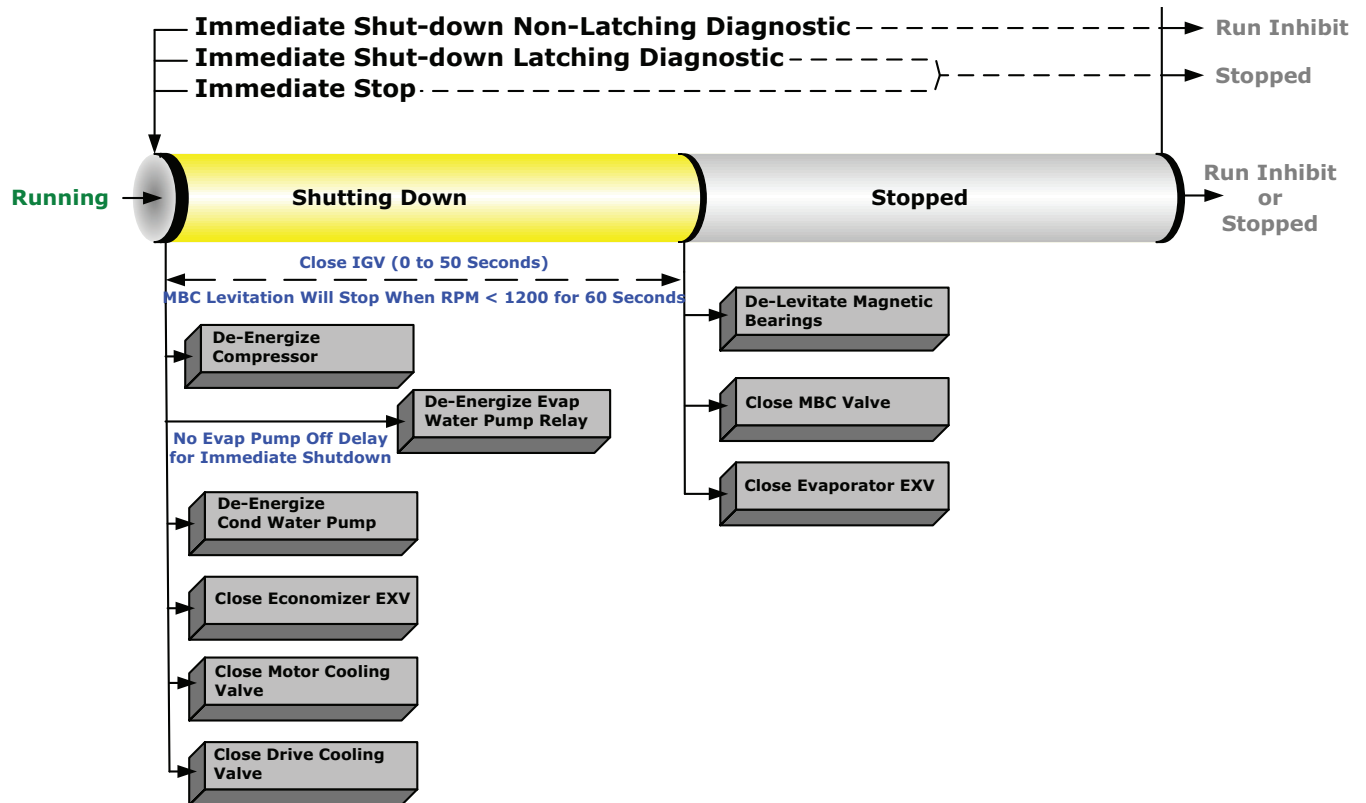

AFD Mains Phase Loss

The following figure shows how the controls act in a power interruption event that the Adaptive Frequency™ Drive

(AFD) diagnoses as a AFD Mains Phase Loss (MPL) diagnostic.

Figure 43. Sequence of events: AFD mains phase loss

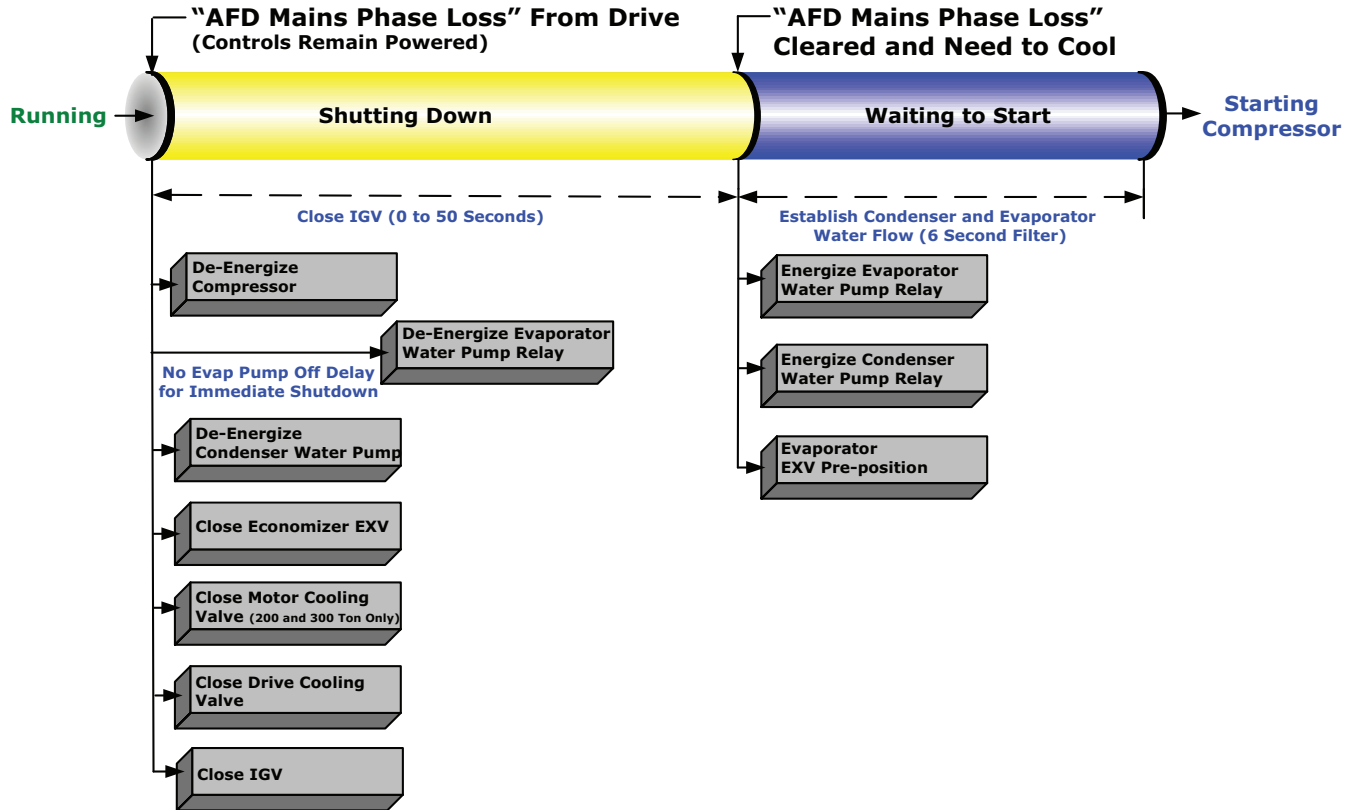

Ice Making (Running to Ice Making to Running)

The following figure shows the transition from normal cooling to ice making, and back to normal cooling.

Figure 44. Sequence of events: ice making (running to ice making to running)

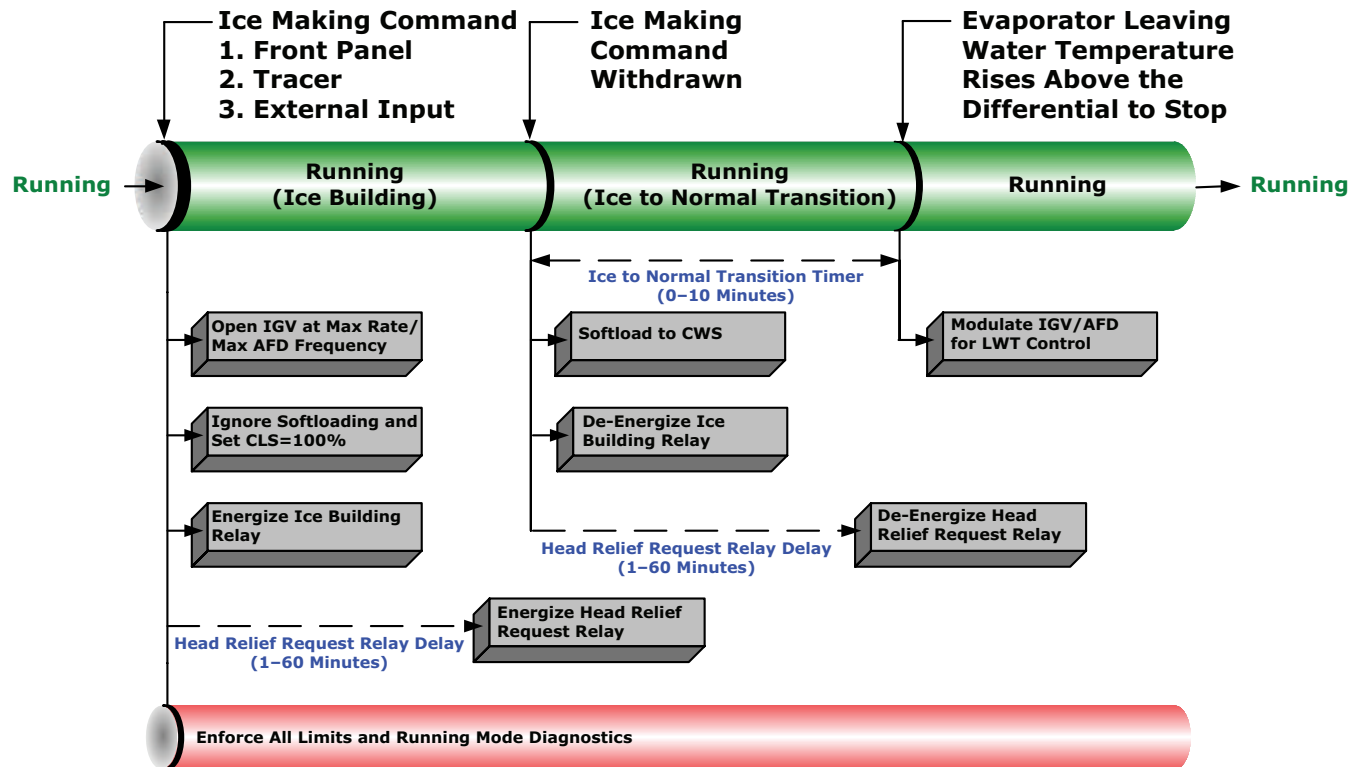

Ice Making (Auto to Ice Making to Ice Making Complete)

The following figure shows the transition from auto to ice making, to ice making complete.

Figure 45. Sequence of events: ice making (auto to ice making to ice making complete)

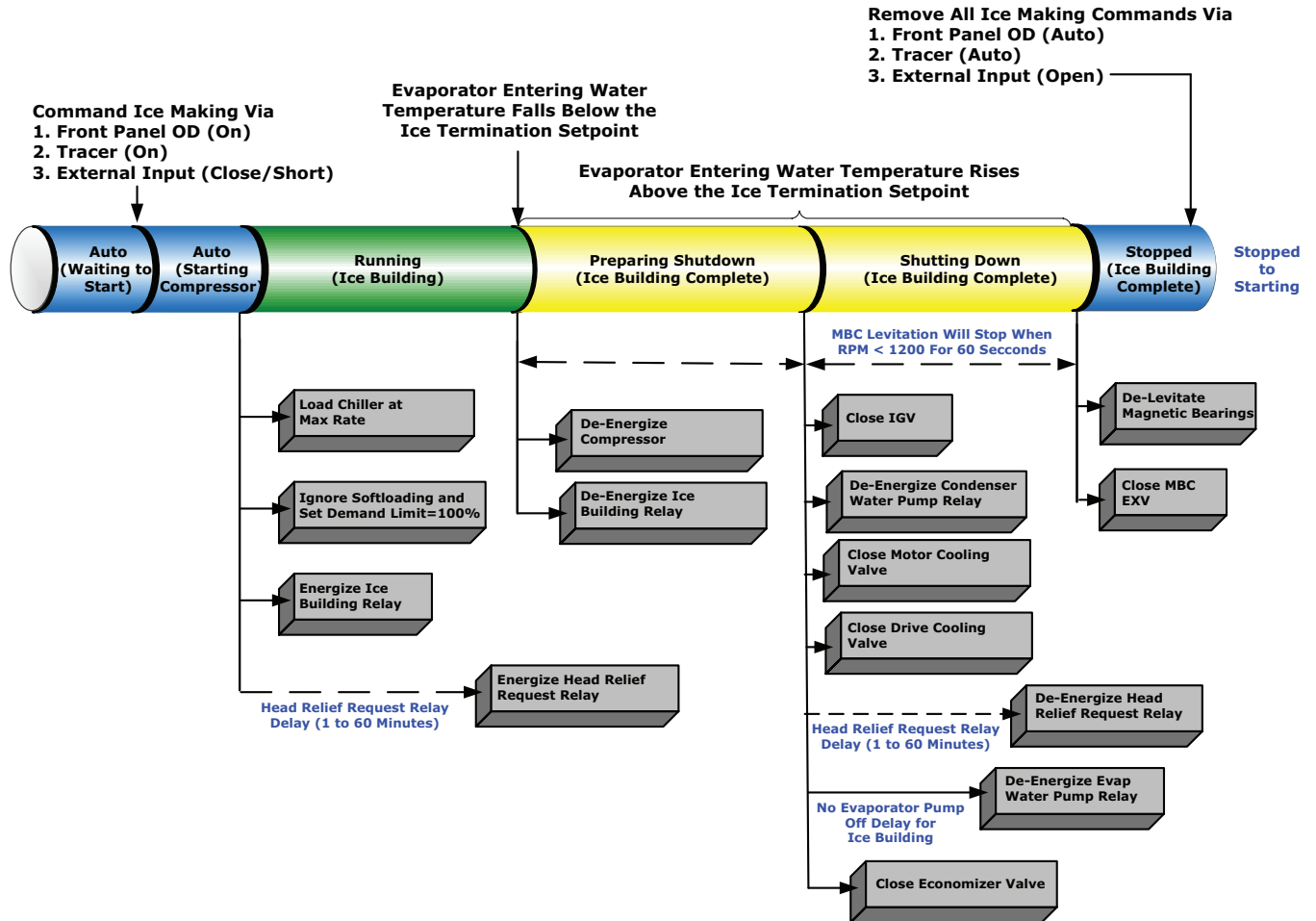

Limit Conditions

The controller will automatically limit certain operating parameters during startup and run modes to maintain

optimum chiller performance and prevent nuisance diagnostic trips. These limit conditions are noted in the following table.

Table 20. Limit conditions

Condition	Description
Running - Limit	The chiller, circuit, and compressor are currently running, but the operation of the chiller/compressor is being actively limited by the controls. Further information is provided by the sub-mode.
Condenser Pressure Limit	The circuit is experiencing condenser pressures at or near the condenser limit setting. The compressor will be unloaded to prevent exceeding the limits.
Evaporator Refrigerant Temperature Limit	The circuit is experiencing saturated evaporator temperatures at or near the Low Refrigerant Temperature Cutout setting. The compressors will be unloaded to prevent tripping.
Current Limit	The compressor is running and its capacity is being limited by high currents. The current limit setting is 100% RLA (to avoid overcurrent trips).
AFD Heat Sink Temperature Limit	This limit will unload the chiller if the communicated heat sink temperature approaches cutout.
Demand Limit	This limit allows the customer to control the maximum power into the chiller.

Control Panel Devices and Unit-Mounted Devices

Unit Control Panel

Safety and operating controls are housed in the unit control panel and the starter panel. The control panel operator interface is called Tracer® AdaptiView™ and is located on an adjustable arm connected to the side of the control panel. For more information about operating Tracer® AdaptiView™, refer to *Tracer® AdaptiView™ Display for Water-cooled Agility Chillers with Symbio™ Operations Guide* (HDWA-SVU002*-EN). For more information on the Symbio™ 800 controller, refer to *Symbio™ 800 Controller Installation, Operation, and Maintenance* (BAS-SVX080*-EN).

The control panel houses several other controls modules called panel-mounted Low Level Intelligent Devices (LLIDs), power supply, terminal block, fuse, circuit breakers, and transformer. The inter-processor communication (IPC) bus allows the communications between LLIDs and the controller. Unit-mounted devices are called frame-mounted LLIDs and can be temperature sensors or pressure transducers. The Modbus® client connection on the controller provides communication to the TR200 AFD and to the Magnetic Bearing Controller (MBC). These and other functional switches provide analog and binary inputs to the control system.

User-defined Language Support

Tracer® AdaptiView™ is capable of displaying English text or any of 26 other languages (27 total languages). Switching languages is simply accomplished from a Language Settings menu. The following languages are available:

- Arabic (Gulf Regions)
- Chinese—China
- Chinese—Taiwan
- Czech

- Dutch
- English
- French
- French (Canada)
- German
- Greek
- Hebrew
- Hungarian
- Indonesian
- Italian
- Japanese
- Korean
- Norwegian
- Polish
- Portuguese (Portugal)
- Portuguese (Brazil)
- Russian
- Romanian
- Spanish (Europe)
- Spanish (Latin America)
- Swedish
- Thai
- Turkish



Unit Start-up and Shutdown Procedures

⚠ WARNING

Live Electrical Components!

Failure to follow all electrical safety precautions when exposed to live electrical components could result in death or serious injury.

When it is necessary to work with live electrical components, have a qualified licensed electrician or other individual who has been properly trained in handling live electrical components perform these tasks.

⚠ WARNING

Asphyxiation Hazard!

Failure to follow instructions below could result in death or serious injury. A significant release of refrigerant into a confined space could displace available oxygen to breathe and cause possible asphyxiation.

Should a refrigerant release occur, evacuate the area immediately and contact the appropriate rescue or response authority.

- Do not run evaporator water pump longer than 30 minutes after the chiller is shut down.
 - Ensure that the evaporator is isolated from the hot water loop before changeover to heating mode.
- The relief device is designed to relieve and discharge the refrigerant from the unit if the pressure in the evaporator exceeds 200 psig (1379.0 kPaG) on the evaporator or 300 psig (2068.4 kPaG) on the condenser.

Unit Start-up

NOTICE

Equipment Damage!

Failure to follow instructions could result in equipment damage.

Ensure that the Uninterruptible Power Supply (UPS) has been operating properly for a minimum of 10 hours before starting.

If required, after the system has been operating for approximately 30 minutes and has become stabilized, complete the remaining start-up procedure, as follows:

1. Check evaporator and condenser refrigerant pressures under Condenser and Evaporator Reports on the Tracer® AdaptiView™. The pressures are referenced to sea level (14.6960 psia [101.3254 kPaA]).

Temporary Shut-down and Restart

To shut down for a short time, use the following procedure:

1. Press the STOP key on the Tracer® AdaptiView™.
2. Symbio™ 800 pump control will turn off the pump (after

a optional water pump delay time) when the STOP key is pressed and automatically restart the pump when the "Auto" key is pressed.

3. The unit will start normally, provided the following conditions exist:
 - a. The Symbio™ 800 receives a call for cooling and the differential-to-start is above the setpoint.
 - b. All system operating interlocks and safety circuits are satisfied.

Extended Unit Shut-down

1. Perform the normal unit stop sequence using the STOP key.

Note: Unless the water bundles are valved off and drained, chiller power should remain ON at all times to allow the magnetic bearings to levitate the rotor in case water flow-driven rotation should occur. Trane recommends leaving the power on to maintain the Uninterruptible Power Supply (UPS) battery.

2. Verify the chilled water and condenser water pumps are cycled off. If desired, open disconnect switches to the pumps.
3. Drain the condenser piping and cooling tower.
4. Remove the drain and vent plugs from the condenser headers to drain the condenser.
5. After the unit is secured, perform the maintenance identified in the following sections.

Seasonal Unit Start-up

1. Close all drain valves and reinstall the drain plugs in the evaporator and condenser headers.
2. Service the auxiliary equipment according to the start-up and maintenance instructions provided by the respective equipment manufacturers.
3. Vent and fill the cooling tower, if used, as well as the condenser and piping. At this point, all air must be removed from the system (including each pass). Then, close the vents in the condenser chilled water circuits.
4. Open all of the valves in the evaporator chilled water circuit.
5. If the evaporator was previously drained, vent and fill the evaporator and chilled water circuit. After all air is removed from the system (including each pass), install the vent plugs in the evaporator waterboxes.

NOTICE

Equipment Damage!

Failure to follow instructions could result in equipment damage.

Ensure that the Uninterruptible Power Supply (UPS) has been operating properly for a minimum of 10 hours before starting.

6. Check the adjustment and operation of each safety and operating control.
7. Close all disconnect switches.
8. Perform instructions listed in [“Unit Start-up,” p. 64.](#)



Maintenance

⚠ WARNING

Hazardous Voltage w/Capacitors!

Failure to disconnect power and discharge capacitors before servicing could result in death or serious injury.

Disconnect all electric power, including remote disconnects and discharge all motor start/run capacitors before servicing. Follow proper lockout/tagout procedures to ensure the power cannot be inadvertently energized. For variable frequency drives or other energy storing components provided by Trane or others, refer to the appropriate manufacturer's literature for allowable waiting periods for discharge of capacitors. Verify with a CAT III or IV voltmeter rated per NFPA 70E that all capacitors have discharged.

Recommended Maintenance

Weekly

While the unit is running in stable conditions:

- Log the chiller.
- Check evaporator and condenser pressures with gauges and compare to the reading on the Tracer® AdaptiView™ or Tracer® TU service tool. Pressure readings should fall within operating ranges specified in the following tables. If chiller measurements vary significantly from values listed in the following tables, problems may exist with refrigerant charge levels. Contact your local Trane Service Agency.

Note: Optimum condenser pressure is dependent on condenser water temperature, and should equal saturation pressure of refrigerant at a temperature 2°F to 5°F (1.1°C to 2.8°C) above that of leaving condenser water at full load.

Monthly

- Review operating log.
- Clean all water strainers in both the chilled and condensing water piping systems.

Annual

Contact your local Trane Service Agency to shut down the chiller once each year and perform the following:

- Perform all weekly and monthly maintenance procedures.
- Leak check the chiller, inspect safety controls, and inspect electrical components, such as magnetic bearing controller and Uninterruptible Power Supply (UPS).
- Inspect all piping components for leakage and/or damage. Clean out any in-line strainers.

- Clean and repaint any areas that show signs of corrosion.
- Inspect vent piping of all relief valves for presence of refrigerant to detect improperly sealed relief valves.
- Inspect the condenser tubes for fouling. Clean if necessary; refer to "Cleaning the Condenser," p. 67.
- Visually inspect waterbox hinges to ensure that hinges have not been damaged or altered.

Note: If, after 10 years, the battery has not been replaced, Trane recommends replacing the battery.

Other

- Use a nondestructive tube test to inspect the condenser and evaporator tubes at 3-year intervals.

Note: It may be desirable to perform tube tests on these components at more frequent intervals, depending upon chiller application. This is especially true of critical process equipment.

Ask your Sales account manager for a copy of engineering bulletin (CTV-PRB024*-EN) for clarification of the role of eddy current testing in chiller maintenance by providing information about eddy current technology and heat exchanger tubing.

- Depending on chiller duty, contact your local Trane Service Agency to determine when to conduct a complete examination of the unit to determine the condition of the compressor and internal components.

Maintenance Procedures

Drive Cooling System

NOTICE

Equipment Damage!

Use of unapproved fluids, or dilution of approved fluid, could result in catastrophic equipment damage. Use only Trane Heat Transfer Fluid P/N CHM01023. This fluid is a direct use concentration and is not to be diluted. Do not top off with water or any other fluid.

Service Intervals

NOTICE

Equipment Damage!

Failure to follow instructions could result in equipment damage. Drive cooling fluid and strainer must be serviced every five (5) years.

Interval	Task
5 years	Drain and replace the drive cooling fluid
5 years	Replace the fluid strainer when servicing the fluid
Yearly	Perform a fluid pH test.

Unit Diagnostics

An improperly filled drive cooling system (either low fluid level or entrapped air in the circuit) can result in the AFD or output filter overheating. This condition may result in the following diagnostics:

- AFD Fault
- Loss of Drive Cooling Control

If chiller diagnostics indicate a drive cooling system problem, contact your local Trane Service Agency.

pH Test

Obtain a sample of fluid from the drive cooling loop via the loop drain located near the discharge of the pump. Test for pH level using litmus paper with a 0.5 resolution.

- pH < 8 indicates fluid to be changed

Pressure Relief Cap

The pressure relief cap is an automotive style pressure-vent radiator cap; refer to the following figure. The setting for the relief spring is 16 lb (7.3 kg). The function of the relief cap can be verified with a standard automotive radiator cap tester.

Figure 46. Pressure relief cap

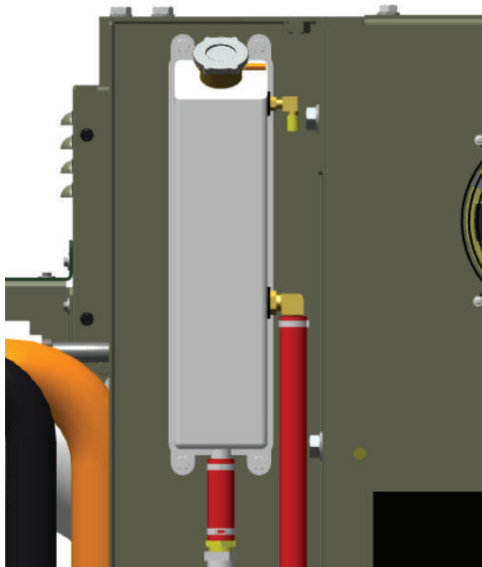

Drive Cooling Expansion Tank

Proper fluid level is important to the operation of the unit. To verify proper level, inspect the liquid level in the fluid reservoir (located on the left side of the electrical panel);

refer to the following figure for fluid levels under various temperature conditions.

Figure 47. Drive cooling expansion tank fill

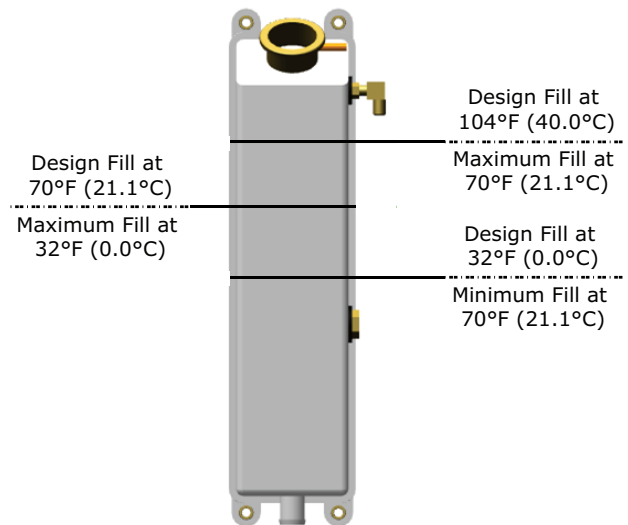

Note: Fill lines are NOT marked on the tank. The top level is just below the upper fitting and the bottom level is just above the lower fitting; the middle level is midway between the two fittings.

Cleaning the Condenser

Condenser tube fouling is suspect when the “approach” temperature (i.e., the difference between the refrigerant condensing temperature and the leaving condenser water temperature) is higher than predicted.

Condenser tube fouling is indicated when the approach temperature (the difference between the condensing refrigerant temperature and the leaving condenser water temperature) is higher than predicted. Refer to sales order selection data for approach temperatures.

Note: Glycol in the water system typically doubles the standard approach.

If the annual condenser tube inspection indicates that the tubes are fouled, two cleaning methods (mechanical or chemical) can be used to rid the tubes of contaminants. The methods are described in the following sections.

Mechanical Cleaning

Mechanical tube cleaning is used to remove sludge and loose material from smooth-bore condenser tubes.

⚠ WARNING

Heavy Objects!

Failure to properly lift waterbox could result in death or serious injury.

Each of the individual cables (chains or slings) used to lift the waterbox must be capable of supporting the entire weight of the waterbox. The cables (chains or slings) must be rated for overhead lifting applications with an acceptable working load limit. Refer to the waterbox weights table.

Waterbox Removal

Review mechanical room limitations and determine the safest method or methods of rigging and lifting the waterboxes.

Important:

- Do NOT rotate waterboxes.
- Be sure to replace water boxes right-side-up to maintain proper baffle orientation. Use new O-rings.
- if the waterbox is reversed, be sure to match mark on the baffle and waterbox to ensure that they are aligned.

1. Determine the size of chiller being serviced. See unit nameplate located on chiller control panel.
2. Use a 3/8-in. (9.5-mm) rigging shackle for waterbox removal as shown in the following figure. The rated lifting capacity of the selected lift connection device must meet or exceed the published weight of the waterbox. Refer to the tables in “Waterbox Reassembly,” p. 68.
3. Install rigging shackle onto the lifting connection on the waterbox.
4. Disconnect water pipes, if connected.
5. Match mark on the waterbox and the baffle to ensure that they are aligned.

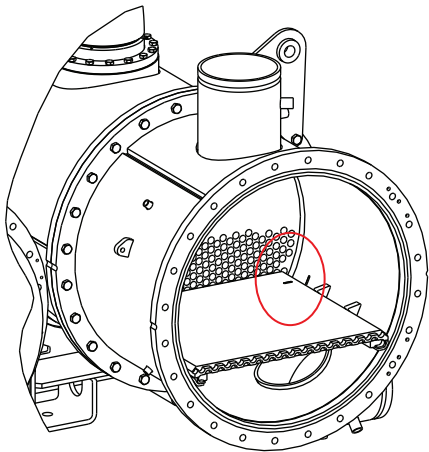

6. Remove waterbox bolts.

⚠ WARNING

Overhead Hazard!

Failure to follow instructions could result in death or serious injuries.

Never stand below or in close proximity to heavy objects while they are suspended from, or being lifted by, a lifting device in case the object drops.

7. Lift the waterbox away from the shell.
8. Store the waterbox in a safe and secure location and position.
9. Work a round nylon or brass bristled brush (attached to a rod) in and out of each of the condenser water tubes to loosen the sludge.
10. Thoroughly flush the condenser water tubes with clean water.

Note: To clean internally enhanced tubes, use a bi-directional brush or consult a qualified service organization for recommendations.

Figure 48. Waterbox and 3/8-in. (9.5-mm) rigging shackle

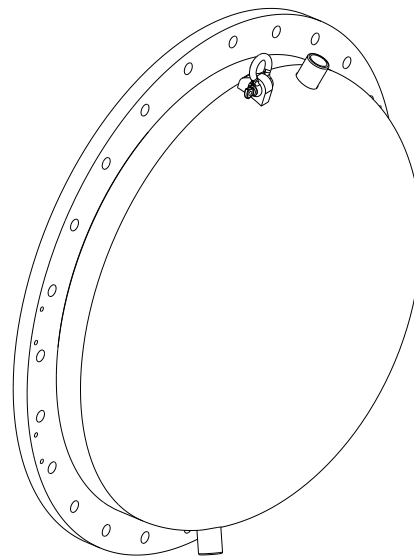

Waterbox Reassembly

After service is complete, the waterbox should be reinstalled on the shell following removal procedures in reverse (refer to “Waterbox Removal,” p. 68). After thoroughly cleaning each joint, use new O-rings on ALL joints. Torque waterbox bolts in a star pattern to 163 ft·lb (221.0 N·m) dry.

Table 21. Waterbox weights

Shell Size	Description	Fabricated Non-marine Waterbox Welded Dome		Marine Waterbox Cover	
		lb	kg	lb	kg
020	Condenser Supply	145	65.8	253	115
	Evaporator Supply	170	77.1	253	115
	Return	100	45.4	NA	NA
040	Condenser Supply	210	95.3	395	179
	Evaporator Supply	245	111.1	395	179
	Return	145	65.8	NA	NA

Note: Each optional waterbox hinge weighs 44 lb (19.94 kg)

Obtain the required parts from your local Trane Parts Center.

Chemical Cleaning

Scale deposits are best removed by chemical means. Consult a qualified water treatment specialist (i.e., one that knows the local water supply chemical/mineral content) for a recommended cleaning solution suitable for the job. (A standard condenser water circuit is composed solely of copper, cast iron and steel.) Improper chemical cleaning can damage tube walls.

All of the materials used in the external circulation system, the quantity of the solution, the duration of the cleaning period, and any required safety precautions should be approved by the company furnishing the materials or performing the cleaning.

Note: Chemical tube cleaning should ALWAYS be followed by mechanical tube cleaning.

Cleaning the Evaporator

Because the evaporator is typically part of a closed circuit, it does not accumulate appreciable amounts of scale or sludge. However, if cleaning is deemed necessary, use the same cleaning methods described in “Cleaning the Condenser,” p. 67.

Waterbox Hinges

The hinged waterbox option is available for the evaporator, the condenser, or both. This option can be ordered with the hinge only on the evaporator and/or only on the condenser; however, the hinges MUST be ordered for both ends of the evaporator and/or the condenser.

The hinged waterbox option does NOT require annual maintenance or lubrication, although a visual inspection is recommended to ensure that the hinges have not been damaged or altered. For assembly and disassembly of hinges, please refer to *Agility™ Water-cooled Chillers With Symbio™ Controls Disassembly and Reassembly Installation Guide* (HDWA-SVN003*-EN).

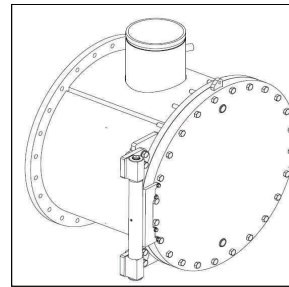
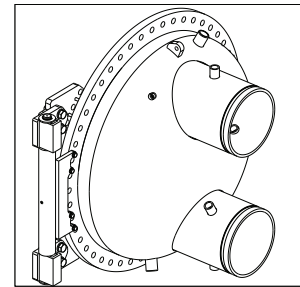
MARINE

NON-MARINE

Adaptive Frequency Drive Periodic Maintenance and Inspection

Adaptive Frequency™ Drive (AFD) periodic maintenance and inspections should be performed every 1–12 months, depending on operating environment.

Visual Inspection—Power Removed

⚠ WARNING

Hazardous Voltage w/Capacitors!

Failure to disconnect power and discharge capacitors before servicing could result in death or serious injury.

Disconnect all electric power, including remote disconnects and discharge all motor start/run capacitors before servicing. Follow proper lockout/tagout procedures to ensure the power cannot be inadvertently energized. For variable frequency drives or other energy storing components provided by Trane or others, refer to the appropriate manufacturer’s literature for allowable waiting periods for discharge of capacitors. Verify with a CAT III or IV voltmeter rated per NFPA 70E that all capacitors have discharged.

1. Ensure the door interlocks are present and working.
2. Verify the safety ground connections to the door panels are securely connected.
3. Inspect power wire cables and devices to assure no abrasion is occurring from vibrations against chassis of cabinets, or other edges.
4. Ensure the drive interior and exterior is clear of any dust or debris. Fans, vents, etc. must be clean.
Important: Only use a vacuum for cleaning. Do NOT use compressed air.
5. Inspect the interior of the drive for any signs of moisture entry or leakage.
6. Visually inspect all drive components and wiring. Look for signs of heat or failure (look for swelled or leaking capacitors, discolored reactors or inductors, broken



Maintenance

pre-charge resistors, smoke or arc trails on MOVs and capacitors, etc.).

7. Closely inspect the motor terminal board for any signs of leakage, arcing, etc..
8. Check ALL cable/lug/terminal connections inside the drive enclosure. Ensure all are clean and tight, and not rubbing against each other anywhere.
9. Test pH levels annually. Replace fluid as necessary, or every 5 years.
10. Remove and clean electrical panel air filters.

Operational Inspection—Power Applied

⚠ WARNING

Live Electrical Components!

Failure to follow all electrical safety precautions when exposed to live electrical components could result in death or serious injury.

When it is necessary to work with live electrical components, have a qualified licensed electrician or other individual who has been properly trained in handling live electrical components perform these tasks.

1. Verify the drive cabinet cooling fans are operating. This should be done from outside the enclosure, by looking into the cabinet at door and cabinet vents, to avoid electrical hazards.

Note: *The power module fan comes on with power. Other fans cycle with drive operation.*

2. Check historic fault codes using Adaptive Frequency™ Drive (AFD) control panel (LCP).

Note: *The AFD control panel is used ONLY for service and should never be used for machine operation.*

3. Check configuration settings and confirm all proper settings are still present in the controls.
4. Review the diagnostic history.
5. Make Chiller Service report to document all setpoints.
6. Check the Symbio™ 800 alarm histories for any indications of operational problems.



Wiring

The following tables provide lists of field wiring diagrams, electrical schematics, and connection diagrams for Agility™ chillers. To determine the specific electrical characteristics of a particular chiller, refer to the nameplates mounted on the units.

Table 22. Wiring drawings

Drawing	Description
2311-5485	Diagram — Schematic Wiring; Standard
2311-5486	Diagram — Field Wiring; Harmonic Filter
2311-5487	Diagram — Schematic Wiring; Autotransformer
2311-5532	Diagram — Field Wiring; Unit-mounted Low Voltage AFD (240~678A Range)



Appendix A: Forms and Check Sheets

The following forms and check sheets are included for use with Trane start-up of HDWA Agility™ chillers. Forms and check sheets are used, as appropriate, for installation completion verification before Trane start-up is scheduled, and for reference during the Trane start-up.

Where the form or check sheet also exists outside of this publication as standalone literature, the literature order number is also listed.

- CTV Form — Installation Completion and Request for Trane Service (HDWA-ADF003*-EN)
- Settings

- Operator Log

Unit Start-up/Commissioning

Important: *Start-up must be performed by Trane or an agent of Trane specifically authorized to perform start-up and warranty of Trane® products. Contractor shall provide Trane (or an agent of Trane specifically authorized to perform start-up) with notice of the scheduled start-up at least two weeks prior to the scheduled start-up.*



Appendix B: Chiller Installation Completion and Request for Trane Service

Important: A copy of this completed form must be submitted to the Trane Service Agency that will be responsible for the start-up of the chiller. Start-up will NOT proceed unless applicable items listed in this form have been satisfactorily completed.

To: _____

Trane Service Office: _____

S.O. Number: _____

Serial Numbers: _____

Job/Project Name: _____

Address: _____

The following items are being installed and will be completed by: _____

Important: Start-up must be performed by Trane or an agent of Trane specifically authorized to perform start-up and warranty of Trane® products. Contractor shall provide Trane (or an agent of Trane specifically authorized to perform start-up) with notice of the scheduled start-up at least two weeks prior to the scheduled start-up. **Equipment not started by Trane is not warranted by Trane.**

Check box if the task is complete or if the answer is "yes".

1. Chiller

- Installation meets foundation requirements.
- In place and piped.
- Isolation pads installed.

Note: Do not insulate the Agility™ chiller or adjacent piping prior to the chiller commissioning by Trane service personnel. The contractor is responsible for any foreign material left in the unit.

2. Piping

Chilled water piping connected to:

- Evaporator
- Air handling units
- Pumps
- Flow switch or flow proving device installed (if not factory-provided)

Condenser piping connected to:

- Condenser

- Pumps
- Flow switch or flow proving device installed (if not factory-provided)
- Cooling tower

Additional piping:

- Make-up water connected to cooling tower
- Water supply connected to filling system
- Does unit have freeze inhibitor? If unit has freeze inhibitor:
 - Verify type and concentration correct per unit submittal
 - Calculate and record freeze point of the solution: _____ (specify °F or °C)
- Systems filled
- Pumps run, air bled from system
- Strainers installed in entering water piping (evaporator and condenser) and cleaned
- Relief valve ventilation piping installed (as applicable)

3. Flow balancing valves installed

- Leaving chilled water
- Leaving condenser water
- Proper porting to measure flow and balance

4. Gauges, thermometers, and air vents

- Installed on both sides of evaporator
- Installed on both sides of condenser

5. Wiring

- Wire size per submittal and NEC 310-16
- Full power available
- External interlocks (flow switch, pumps auxiliary, etc.)
- Chilled water pump (connected and tested)
- Condenser water pump (connected and tested)
- Cooling tower fan rotation checked
- 115 Vac power available for service tools (as required)
- All controls installed and connected
- Indicate type of power distribution grounding
- If unit was disassembled for installation, all interconnecting wiring reinstalled
- Indicate power distribution grounding type:
 - Solidly Grounded (Center Ground Wye)

-or-



Appendix B: Chiller Installation Completion and Request for Trane Service

- Non-Solidly Grounded (Any Delta, High Impedance Ground, or Ungrounded Wye)

6. Testing

- Dry nitrogen available for pressure testing
- Trace gas amounts of R-134a available for leak testing (if necessary)

7. Refrigerant

- Refrigerant on job site and in close proximity to chiller (if shipped separately)
 - Total amount in cylinders/drums: _____ (specify lb or kg) and fill in specifics below:
 - Number of cylinders/drums _____ of size _____ (specify lb or kg)
 - Number of cylinders/drums _____ of size _____ (specify lb or kg)

Note: After commissioning is complete, it is the installer's responsibility to transport empty refrigerant containers to an easily accessible point of loading to facilitate container return or recycling.

8. System

- Systems can be operated under all design selection points to verify proper operation.

9. Equipment room

- Does the equipment room have a refrigerant monitor/sensor capable of monitoring and alarming within the allowable exposure level of the refrigerant?
- Does the installation have properly placed and operating audible and visual refrigerant alarms?
- Does the equipment room have proper mechanical ventilation?
- If it is required by local code, is a self-contained breathing apparatus available?
- Does the equipment room meet environmental condition requirements specified in the chiller *Installation, Operation, and Maintenance* manual?

10. Owner awareness

- Has the owner been fully instructed on the proper use and handling of refrigerant?
- Does the owner have a copy of the MSDS for refrigerant?

Note: Additional time required to properly complete the start-up and commissioning, due to any incompleteness of the installation, will be invoiced at prevailing rates.

This is to certify that the Trane equipment has been properly and completely installed, and that the applicable items listed above have been satisfactorily completed.

Checklist completed by: _____ (Print Name):
 Signed: _____
 Date: _____

In accordance with your quotation and our purchase order number _____, we therefore require the presence of Trane service on this site, for the purpose of start-up and commissioning, by _____ (date).

Note: Minimum of two week advance notification is required to allow for scheduling of the chiller start-up.

Additional Comments/Instructions:

Note: A copy of this completed form must be submitted to the Trane Service Agency that will be responsible for start-up of chiller.



Appendix C: Settings

Chiller Settings	Value
Setpoint Source	
Front Panel Hot Water Command	
Front Panel Chilled Water Setpoint	
Front Panel Hot Water Setpoint	
Front Panel Ice Building Command	
Ice Termination Setpoint	
Ice to Normal Cooling Timer Setpoint	
Front Panel Demand Limit Setpoint	
Front Panel Base Loading Setpoint	
Front Panel Base Loading Command	
Differential to Start	
Differential to Stop	
Condenser Water Pump Off Delay	
Evaporator Water Pump Off Delay	
Evap Low Water Flow Warning Setpoint	
Power-Up Start Delay	
Chiller Power Demand Time Period	
Service Settings	Value
Low Evaporator Water Temp Cutout	
Low Refrigerant Temperature Cutout	
Local Atmospheric Pressure	
Maximum Capacity Limit	
Minimum Capacity Limit	
Capacity Control Softload Time	
Demand Limit Softload Time	
Demand Limit Startup Target	
Condenser Pressure Limit Setpoint	
Feature Settings	Value
Ext Chilled/Hot Water Setpoint Enable	
External Demand Limit Setpoint Enable	
Ice Building Feature Enable	
Minimum Capacity Timer	
Security	
External Base Loading Setpoint Enable	
Chilled Water Reset	Value
Chilled Water Reset Type	
Return Water Reset Ratio	
Return Water Start Reset	
Return Water Maximum Reset	
Outdoor Air Reset Ratio	
Outdoor Air Start Reset	
Outdoor Air Maximum Reset	



Appendix C: Settings

Manual Control Settings	Value
Evaporator Water Pump Override	
Condenser Water Pump Override	
Manual Capacity Control	
Clear Energy Consumption	
Display Settings	Value
Date Format	
Date Separator	
Time Format	
Unit System	
Pressure Units	
Language	
Date	
Time	
UTC Offset	
Summer Time	



Appendix D: Operator Log

Note: An Operator Log can be captured by using the “Logsheet Report” found on the Tracer® AdaptiView™ display; refer to the following figures.

Figure 49. Reports, Log Sheet button highlighted

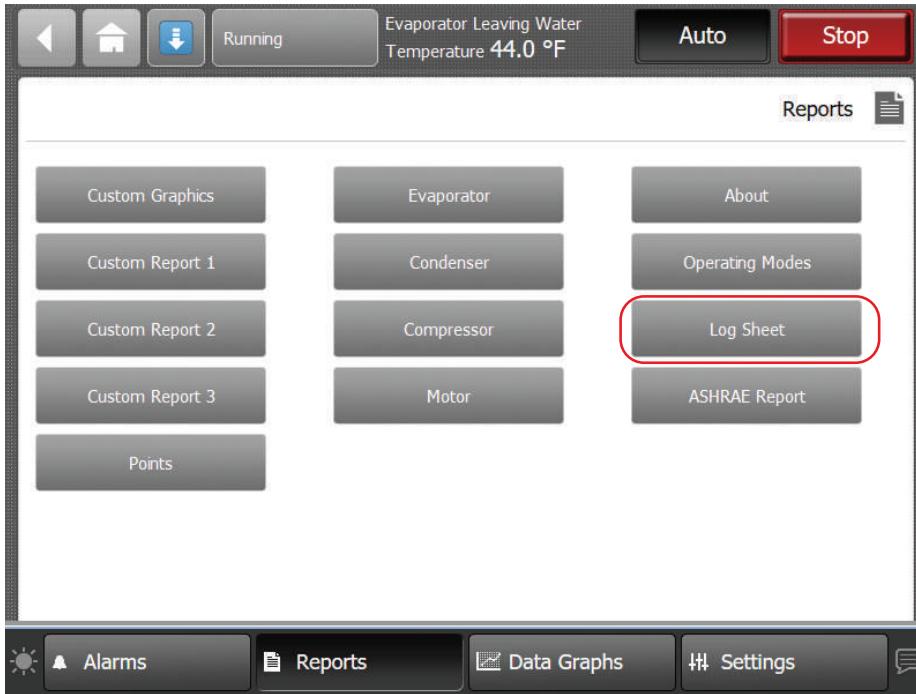
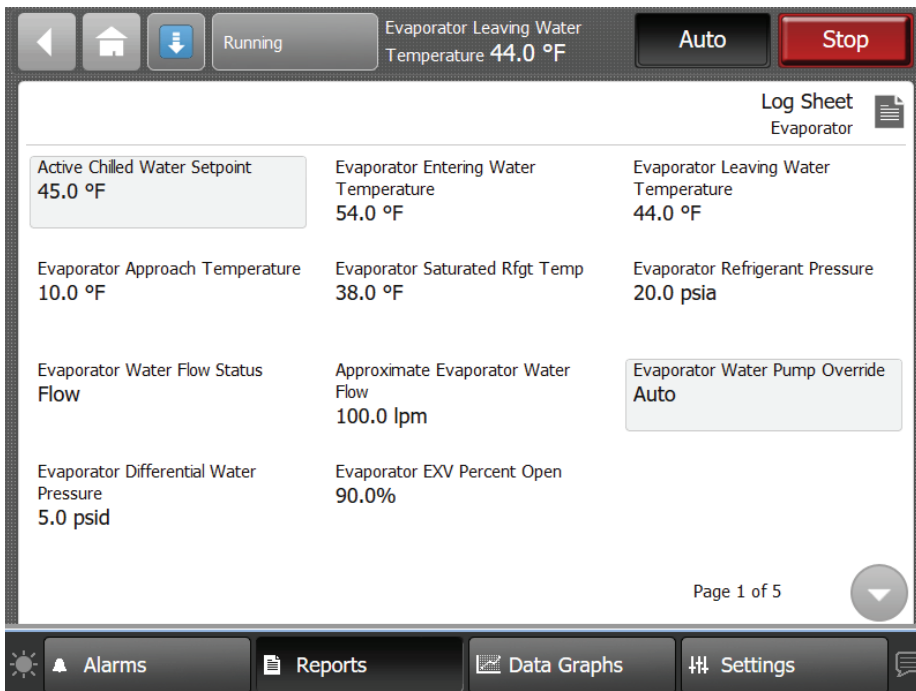

Figure 50. Sample Agility chiller Log Sheet





Appendix D: Operator Log

Data Name	Run Time		
	15 Minutes	30 Minutes	1 Hour
Evaporator			
Active Chilled Water Setpoint			
Evaporator Entering Water Temperature			
Evaporator Leaving Water Temperature			
Evaporator Approach Temperature			
Evaporator Saturated Rfgt Temp			
Evaporator Refrigerant Pressure			
Evaporator Water Flow Status			
Approximate Evaporator Water Flow			
Evaporator Water Pump Override			
Evaporator Differential Water Pressure			
Evaporator EXV Percent Open			
Condenser			
Active Hot Water Setpoint			
Condenser Entering Water Temperature			
Condenser Leaving Water Temperature			
Condenser Approach Temperature			
Condenser Saturated Rfgt Temp			
Condenser Refrigerant Pressure			
Condenser Water Flow Status			
Approximate Condenser Water Flow			
Condenser Water Pump Override			
Condenser Differential Water Pressure			
Differential Refrigerant Pressure			
Condenser Refrigerant Liquid Level			
Compressor			
Compressor Running Status			
Compressor Starts			
Compressor Running Time			
Chiller Load Command			
Compressor Discharge Temperature			
IGV Percent Open			
Compressor Bearing Temperature 1			
Compressor Bearing Temperature 2			
MBC PCB Temperature			
MBC Cooling Valve Percent Open			
Motor			
Active Demand Limit Setpoint			
Percent Chiller Power			
AFD Percent Speed			
AFD Average Motor Current % RLA			
AFD Calculated Motor Voltage			
Chiller Load Command			
AFD Motor Current U % RLA			
AFD Motor Current V % RLA			
AFD Motor Current W % RLA			
AFD Motor Current U			
AFD Motor Current V			

Appendix D: Operator Log

Data Name	Run Time		
	15 Minutes	30 Minutes	1 Hour
AFD Motor Current W			
Unit Power Consumption			
Chiller Power Demand			
Motor Winding Temp #1			
Motor Winding Temp #2			
Motor Winding Temp #3			
Motor Temperature			
AFD Heatsink Temperature			

Trane - by Trane Technologies (NYSE: TT), a global innovator - creates comfortable, energy efficient indoor environments for commercial and residential applications. For more information, please visit trane.com or tranetechnologies.com.

Trane has a policy of continuous product and product data improvements and reserves the right to change design and specifications without notice. We are committed to using environmentally conscious print practices.

HDWA-SVX002C-EN 30 Sep 2023
Supersedes HDWA-SVX002B-EN (November 2022)

©2023 Trane