



Installation Operation and Maintenance Manual

CXAU Centralized Controller MODBUS Communication

TRANE		2023/02/13	08:55:11	Stop	Cooling
General Setting	Advanced Setting	Parameter	Language Setting	Other Settings	
Unit 9	Ambient temperature -0.1 °C	Entering Water Temperature -0.1 °C	Leaving Water Temperature -0.1 °C		
Unit 10	Ambient temperature -0.1 °C	Entering Water Temperature -0.1 °C	Leaving Water Temperature -0.1 °C		
Unit 11	Ambient temperature -0.1 °C	Entering Water Temperature -0.1 °C	Leaving Water Temperature -0.1 °C		
Unit 12	Ambient temperature -0.1 °C	Entering Water Temperature -0.1 °C	Leaving Water Temperature -0.1 °C		

Home
Group
User
Alarms
Service
ON



Contents

1 Features.....	3
2 Installation Guide.....	3
2.1 Installation.....	3
2.2 Wire Instruction.....	3
3 Operation.....	4
3.1 Centralized Controller Address Settings.....	4
3.2 Communication Port.....	5
3.3 Ethernet communication interface.....	5
4 Communication protocol.....	5
4.1 Modbus Directive definitions.....	5
4.2 Modbus Data register address table.....	10
5 Alarms and Troubleshooting.....	15
6 Versions.....	16

1 Feature

- The device is used for centralized control of Trane air conditioning modular CXAU products, and up to 16 CXAU units can be connected to one device;
- Mounting: 4 x 7mm mounting holes.
- Overall dimensions (W x H x D): 250 x 220 x 90 (mm).
- Working power supply: 220/230VAC.
- Working environment: temperature -10~60°C, humidity < 90% RH.
- Storage environment: temperature -20~70°C, humidity < 90% RH.

2 Installation Guide

2.1 Installation

Precautions

- The equipment should be installed indoors, far away from heat sources, such as vapors or flammable gases, and far away from converter substations.
- Do not install the device in a location exposed to direct sunlight.
- Do not install the device in a location with strong wind or heavy dust.
- Do not install the device in a location prone to rain or high moisture.
- Do not install the device in a location where acids, alkaline substances, or corrosive gases (such as sulfur dioxide, hydrogen sulfide, etc.) are present.
- Do not install the device in a location where combustible gases or volatile combustibles may leak into.
- Do not install the device in a location where small animal nests are likely to occur.
- Do not install the device in a location easily accessible to movable people.

2.2 Wiring Instructions

1. All wiring needs to comply with local laws and regulations.
2. Power cable size recommendation $\geq 0.75\text{mm}^2$
3. Communication line requirements: RS485 wiring must use twisted pair shielded wire RVSP. Wire diameter AWG #16 ~ 18 (American wire standard), or $\geq 0.75\text{mm}^2$ (Chinese wire standard). Twisted pair with the shield. The twisting distance is not more than 5cm.
4. When the power cable is routed parallel to the communication line, enough distance must be maintained.

5. RS485 communication line must use twisted pair shielded wire RVSP, and other types of cables shall not be used instead.
6. RS485 bus must adopt a hand-in-hand structure and must not use a star connection.
7. RS485 communication line should be as far away as possible from high-voltage wire, and can not be routed with the power line, let alone bundled together.
8. Ethernet communication line requirements: Ethernet communication lines must use shielded CAT 5 network cables.

Centralized Controller Diagram:

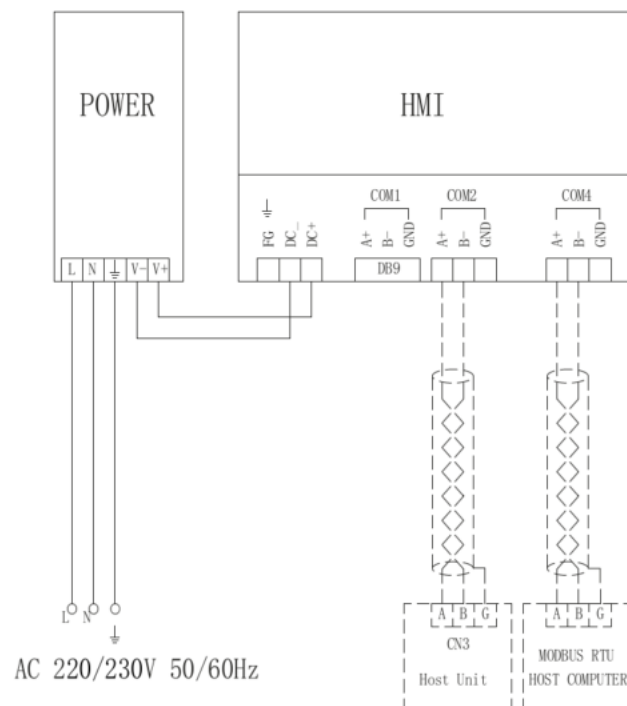

3 Operation

3.1 Centralized Controller Address Settings

Set in User>>Other Settings

For RS485 use, default address for slave unit is 1, changeable.

Ethernet interface:

IP Address:	192.168.0.200	changeable
Subnet Mask:	255.255.255. 0	changeable
Default Gateway:	192.168.0.1	changeable
Port ID:	502	not changeable

3.2 Communication Port

Physical interface: COM4 RS485

Communication protocol: Modbus / RTU

Baud rate setting: 9600,N,8,1

3.3 Ethernet communication interface

Physical interface: RJ45

Communication protocol: Modbus TCP / RTU

4 Communication protocol

4.1 Modbus Directive definitions

1. The communication mode uses Modbus RTU mode. The data format is defined as follows:

Slave address	Request code	Data	CRC16
Module address	Function code	data	Check code

Data is binary data.

CRC16: Cyclic redundancy check.

RTU mode is formatted as per byte (10 bits):

- 1 Start bit、 8 Data bits, The lowest significant bit is sent first (LSB first) 、 Stop bit

Broadcast frames:

Address 0 is used by the host to send broadcast frames, The Modbus module can receive broadcast frames and execute the corresponding requests, but does not return reply frames to the host. Broadcast requests are typically used to write commands.

There can be two ways to talk about master-slave dialogue:

- 1、 The host sends a request to a slave and waits for a response from the slave.
- 2、 The host sends a broadcast to all slaves and does not wait for a response from the slaves.

2.Instructions to read the coil registers (0x01)

➤ Sent by the host unit:

Slave unit address	1 byte	0x01~0x10
Function code	1 byte	0x01

The first address of the register	2 bytes	0x0000 to 0xFFFF
The number of coils read	2 bytes	1 to 2000
CRC16-Lo	1 byte	
CRC16-Hi	1 byte	

➤ Respond from the module:

Slave unit address	1 byte	0x01~0x10
Function code	1 byte	0x01
The length of the data read	2 bytes	0x0000 to 0xFFFF
1st byte	1 byte	
.....
The nth byte	1 byte	
CRC16-Lo	1 byte	
CRC16-Hi	1 byte	

Example: Read the air conditioning system power on and off instructions。

Send		Response	
name	(Hex)	name	(Hex)
Device address	01	Device address	01
Function code	01	Function code	01
Start address Hi	00	Number of bytes	01
Start address Lo	0A	Output status 0 - 7	shutdown[00],startup[01];
The number of output states Hi	00	CRC16 Lo	51
The number of output states Lo	01	CRC16 Hi	88
CRC16 Lo	DD		
CRC16 Hi	C8		

2. Instructions to read discrete registers(0x02)

➤ Sent by the host unit:

Slave unit address	1 byte	0x01~0x10
Function code	1 byte	0x02
The first address on the register	2 bytes	0x0000 to 0xFFFF
The number of coils read	2 bytes	1 to 2000
CRC16-Lo	1 byte	
CRC16-Hi	1 byte	

➤ Respond from the module:

Slave unit address	1 byte	0x01~0x10
Function code	1 byte	0x02
The length of the data read	2 bytes	0x0000 to 0xFFFF
1st byte	1 byte	
.....
The nth byte	1 byte	
CRC16-Lo	1 byte	
CRC16-Hi	1 byte	

Example: Read the power on and off status of the air conditioning system.

Send		Response	
名称	(Hex)	name	(Hex)
Device address	01	Device address	01
Function code	02	Function code	02
Start address Hi	00	Number of bytes	01
Start addressLo	0B	Output status 0 - 7	Shutdown[00],startup[01];
The number of output states Hi	00	CRC16 Lo	A1
The number of output states Lo	01	CRC16 Hi	88
CRC16 Lo	C8		
CRC16 Hi	08		

2. Read save register instructions(0x03)

- Sent by the host unit:

Slave unit address	1 byte	0x01~0x10
Function code	1 byte	0x03
The first address of the register	2 bytes	0x0000 to 0xFFFF
Number of register read	2 bytes	1 to 125
CRC16-Lo	1 byte	
CRC16-Hi	1 byte	

- Respond from the module:

Slave unit address	1 byte	0x01~0x10
Function code	1 byte	0x03
The byte length of the read data	2 bytes	
The first register value	2bytes	
.....
The nth register value	2 bytes	
CRC16-Lo	1 byte	
CRC16-Hi	1 byte	

Example: Read the refrigeration entering temperature setpoint. Its register address is 10000, hexadecimal 0x2710, Its register value is 120 (denote 12°C) , Hexadecimal is 0x78.

Send		Response	
name	(Hex)	name	(Hex)
Device address	01	Device address	01
Function code	03	Function code	03
Start address Hi	27	Number of bytes	02
Start address Lo	10	Register value Hi	00
Number of registers Hi	00	Register value Lo	78
Number of registers Lo	01	CRC16 Lo	B8
CRC16 Lo	8F	CRC16 Hi	66
CRC16 Hi	7B		

2. Read input register instructions(0x04)

- Sent by the host unit:

Slave unit address	1 byte	0x01~0x10
Function code	1 byte	0x04
First address of the register	2 bytes	0x0000 to 0xFFFF
Register number read	2 bytes	1 to 125
CRC16-Lo	1 byte	

CRC16-Hi	1 byte	
----------	--------	--

➤ Feedback from model:

Slave unit address	1 byte	0x01~0x10
Function code	1 byte	0x04
The byte length of the read data	2 bytes	
The first register value	2bytes	
.....
The nth register value	2 bytes	
CRC16-Lo	1 byte	
CRC16-Hi	1 byte	

Example: Read the ambient temperature, entering water temperature and leaving water temperature of Unit 2. Its starting register address is $80+20*2=120$, The corresponding hexadecimal is 0x78, The register values are 152(denote 15.2°C)、304(denote30.4°C)、335(denote33.5°C)respectively。

Send name	(Hex)	Response name	(Hex)
Device address	01	Device address	01
Function code	04	Function code	04
Start address Hi	00	Number of bytes	06
Start address Lo	78	Register value Hi	00
Number of registers Hi	00	Register value Lo	98
Number of registers Lo	03	Register value Hi	01
CRC16 Lo	30	Register value Lo	30
CRC16 Hi	12	Register value Hi	01
		Register value Lo	4F
		CRC16 Lo	00
		CRC16 Hi	D8

3. Write a single coil register instruction(0x05)

➤ Sent by the host unit:

Slave unit address	1 byte	0x01~0x10
Function code	1 byte	0x05
The address of the register	2 bytes	0x0000 to 0xFFFF
The value of the register	2 bytes	close[0x0000] or open[0xFF00]
CRC16-Lo	1 byte	
CRC16-Hi	1 byte	

➤ Respond from the module:

Slave unit address	1 byte	0x01~0x10
Function code	1 byte	0x05
The address of the register	2 bytes	0x0000 to 0xFFFF
The value of the register	2 bytes	close[0x0000] or open[0xFF00]
CRC16-Lo	1 byte	
CRC16-Hi	1 byte	

Example: Write the air conditioning system power on and off instructions, the register address is 10.

Send		Response	
name	(Hex)	name	(Hex)
Device address	01	Device address	01
Function code	05	Function code	05
The address of the register Hi	00	The address of the register Hi	00
The address of the register Lo	0A	The address of the register Lo	0A
The value of the register Hi	FF	The value of the register Hi	FF
The value of the register Lo	00	The value of the register Lo	00
CRC16 Lo	AC	CRC16 Lo	AC
CRC16 Hi	38	CRC16 Hi	38

3. Write a single hold-register instruction(0x06)

➤ Sent by the host unit:

Slave unit address	1 byte	0x01~0x10
Function code	1 byte	0x06
The address of the register	2 bytes	0x0000 to 0xFFFF
The value of the register	2 bytes	0x0000 to 0xFFFF
CRC16-Lo	1 byte	
CRC16-Hi	1 byte	

➤ Respond from the module:

Slave unit address	1 byte	0x01~0x10
Function code	1 byte	0x06
The address of the register	2 bytes	0x0000 to 0xFFFF
The value of the register	2 bytes	0x0000 to 0xFFFF
CRC16-Lo	1 byte	
CRC16-Hi	1 byte	

Example: Write the entering water temperature setpoint. Its register address is 10000,hexadecimal 0x2710, Its register value is 100(denote10°C), hexadecimal is 0x78。

Send		Response	
name	(Hex)	name	(Hex)
Device address	01	Device address	01
Function code	06	Function code	06
The address of the register Hi	27	The address of the register Hi	27
The address of the register Lo	10	The address of the register Lo	10
The value of the register Hi	00	The value of the register Hi	00
The value of the register Lo	64	The value of the register Lo	64
CRC16 Lo	4F	CRC16 Lo	4F
CRC16 Hi	50	CRC16 Hi	50

4. Error response

When the slave cannot execute the host's request, this frame is responded to the host.

Module address	Response code	Error code	CRC16	
0x01~0x0F	83 or 86	1~6	Lo	Hi
1 byte	1 byte	1 byte	2 bytes	

Response Code = Function Code+0x80

Error code:

01 = Illegal features

02 = Illegal data address

03 = Illegal data values

06 = The slave is busy

remark:

1. Hi represents the data high byte, Lo represents a data low byte.
2. The module address changes according to the address set by dialing code SW3.

4.2 Modbus Data register address table

The air conditioning system on/off status(Function code: 0x01[read], 0x05[write])

Register address	Data type	Data name	Range	Default value	Read (R) Write (W)	Description
10	binary	On/off status	(0,1)	0	RW	0:off; 1:on

Air conditioning system power on and off status (function code: 0x02 [read])

Register address	Data type	Data name	Range	Default value	Read (R) Write (W)	Description
11	binary	On/off status	(0,1)	0	R	0:off; 1:on

Air conditioning system setting table (function code: 0x03 [read], 0x06 [write])

Register address	Data type	Data name	Range	Default value	Read (R) Write (W)	Description
10000	word	entering water temperature setpoint in cooling mode, °C	(100,250)	120	RW	Variable value*0.1°C is the temperature value
10001	word	leaving water temperature setpoint in cooling mode, °C	(50,200)	70	RW	Variable value*0.1°C is the temperature value
10002	word	entering water temperature setpoint in heating mode, °C	(250,500)	400	RW	Variable value*0.1°C is the temperature value
10003	word	leaving water temperature setpoint in heating mode, °C	(300,550)	450	RW	Variable value*0.1°C is the temperature value
10004	word	Hot water temperature setpoint, °C	(30,120)	80	RW	Variable value*0.1°C is the temperature value
10020	Word	Current operation mode (cooling/heating)	Current operation mode (cooling/heating)	0	RW	cooling and heating mode

Air conditioning system datasheet (function code: 0x04[read])

Register address	Data type	Data name	Range	Default value	Read (R) Write (W)	Description
10	word	Current operation mode(cooling/heating)	0:Cooling; 1:Heating;		R	
13	word	Number of units	Number of units		R	

No. N machine data sheet (11 in total) (function code: 0x04 [read])

Register address	Data type	Data name	Range	Default	Read (R) Write (W)	Description
80+20*n	word	Ambient temperature (TH1)	(-32768,32767)		R	Variable value*0.1°C is the temperature value
80+20*n+1	word	entering water temperature (TH2)	(-32768,32767)		R	Variable value*0.1°C is the temperature value
80+20*n+2	word	Leaving water temperature (TH3)	(-32768,32767)		R	Variable value*0.1°C is the temperature value
80+20*n+3	word	Total leaving temperature(reserved) (TH4)	(-32768,32767)		R	Variable value*0.1°C is the temperature value
80+20*n+4	word	Unit operating status	0:Undefined; 1:Not activated; 2:Stopped; 3:Starting; 4:run; 5:Stopping		R	
80+20*n+5	word	System 1 operating status	0:Undefined; 1:Not activated; 2:Stopped; 3:Starting; 4:run; 5:Stopping		R	
80+20*n+6	word	System 2 operating status	0:Undefined; 1:Not activated; 2:Stopped; 3:Starting; 4:run; 5:Stopping		R	
80+20*n+7	word	Compressor 1A operating state	0:Undefined; 1:Not activated; 2:Stopped; 3:Starting; 4:run; 5:Stopping		R	
80+20*n+8	word	Compressor 1B operating state	0:Undefined; 1:Not activated; 2:Stopped; 3:Starting; 4:run; 5:Stopping		R	

80+20*n+9	word	Compressor 2A operating state	0:Undefined; 1:Not activated; 2:Stopped; 3:Starting; 4:run; 5: Stopping		R	
80+20*n+10	word	Compressor 2B operating state	0:Undefined; 1:Not activated; 2:Stopped; 3:Starting; 4:run; 5: Stopping		R	

Air conditioning system alarm table 10051—10084 (Total 34) (Function code: 0x02[read])						
Register address	Data type	Data name	Range	Default	Read (R) Write (W)	Description
50	binary	Fault flag	(0,1)	-	R	0:No alarm; 1: Alarm
51	binary	Unit 1 communication alarm	(0,1)	-	R	0:No alarm; 1: Alarm
52	binary	Unit 2 communication alarm	(0,1)	-	R	0:No alarm; 1: Alarm
53	binary	Unit 3 communication alarm	(0,1)	-	R	0:No alarm; 1: Alarm
54	binary	Unit 4 communication alarm	(0,1)	-	R	0:No alarm; 1: Alarm
55	binary	Unit 5 communication alarm	(0,1)	-	R	0:No alarm; 1: Alarm
56	binary	Unit 6 communication alarm	(0,1)	-	R	0:No alarm; 1: Alarm
57	binary	Unit 7 communication alarm	(0,1)	-	R	0:No alarm; 1: Alarm
58	binary	Unit 8 communication alarm	(0,1)	-	R	0:No alarm; 1: Alarm
59	binary	Unit 9 communication alarm	(0,1)	-	R	0:No alarm; 1: Alarm
60	binary	Unit 10 communication alarm	(0,1)	-	R	0:No alarm; 1: Alarm
61	binary	Unit 11 communication alarm	(0,1)	-	R	0:No alarm; 1: Alarm
62	binary	Unit 12 communication alarm	(0,1)	-	R	0:No alarm; 1: Alarm
63	binary	Unit 13 communication alarm	(0,1)	-	R	0:No alarm; 1: Alarm
64	binary	Unit 14 communication alarm	(0,1)	-	R	0:No alarm; 1: Alarm
65	binary	Unit 15 communication alarm	(0,1)	-	R	0:No alarm; 1: Alarm
66	binary	Unit 16 communication alarm	(0,1)	-	R	0:No alarm; 1: Alarm
67	binary	Reserved	(0,1)	-	R	
68	binary	The water pump on the air conditioning side is overloaded	(0,1)	-	R	0:Not overload; 1:overload
69	binary	Hot water side pump overload (reserved)	(0,1)	-	R	0:Not overload; 1:overload
70	binary	Electric heater in the air conditioning side is overloaded	(0,1)	-	R	0:Not overload; 1:overload
71	binary	The entering water temperature sensor alarm	(0,1)	-	R	0:No alarm; 1: Alarm
72	binary	The leaving water temperature sensor alarm	(0,1)	-	R	0:No alarm; 1: Alarm
73	binary	The total leaving temperature sensor alarm	(0,1)	-	R	0:No alarm; 1: Alarm
74	binary	Centralized controller communication alarm	(0,1)	-	R	0:No alarm; 1: Alarm
75	binary	Reserved	(0,1)	-	R	
76	binary	Reserved	(0,1)	-	R	
77	binary	Reserved	(0,1)	-	R	

78	binary	Reserved	(0,1)	-	R	
79	binary	Reserved	(0,1)	-	R	
80	binary	Reserved	(0,1)	-	R	
81	binary	Reserved	(0,1)	-	R	
82	binary	Reserved	(0,1)	-	R	
83	binary	Reserved	(0,1)	-	R	

Unit N alarm table (total 59) (Function code: 0x02[read])

Register address	Data type	Data name	Range	Default	Read (R) Write (W)	Description
100*n	binary	Low Water Flow	(0,1)	-	R	0:no alarm; 1: alarm
100*n+1	binary	Flow Switch Error	(0,1)	-	R	0:no alarm; 1: alarm
100*n+2	binary	Large Diff For EWT and LWT in Heating	(0,1)	-	R	0:no alarm; 1: alarm
100*n+3	binary	EWT and LWT Abnormal	(0,1)	-	R	0:no alarm; 1: alarm
100*n+4	binary	Anti-Freezing 1	(0,1)	-	R	0:no alarm; 1: alarm
100*n+5	binary	Anti-Freezing 2	(0,1)	-	R	0:no alarm; 1: alarm
100*n+6	binary	Outdoor Air Temp Out Of Range	(0,1)	-	R	0:no alarm; 1: alarm
100*n+7	binary	Entering Water Temp Sensor	(0,1)	-	R	0:no alarm; 1: alarm
100*n+8	binary	Leaving Water Temp Sensor	(0,1)	-	R	0:no alarm; 1: alarm
100*n+9	binary	Outdoor Air Temp Sensor	(0,1)	-	R	0:no alarm; 1: alarm
100*n+10	binary	Configuration Error	(0,1)	-	R	0:no alarm; 1: alarm
100*n+11	binary	EEPROM Error	(0,1)	-	R	0:no alarm; 1: alarm
100*n+12	binary	High Inlet Water Temp Limit	(0,1)	-	R	0:no alarm; 1: alarm
100*n+13	binary	High Outlet Water Temp Limit	(0,1)	-	R	0:no alarm; 1: alarm
100*n+14	binary	Sub Board Comm Loss	(0,1)	-	R	0:no alarm; 1: alarm
100*n+15	binary	reserved 1	(0,1)	-	R	0:no alarm; 1: alarm
100*n+16	binary	Compressor Overload Ckt1	(0,1)	-	R	0:no alarm; 1: alarm
100*n+17	binary	Fan Overload Ckt1	(0,1)	-	R	0:no alarm; 1: alarm
100*n+18	binary	Current Abnormal Comp1A	(0,1)	-	R	0:no alarm; 1: alarm
100*n+19	binary	Current Abnormal Comp1B	(0,1)	-	R	0:no alarm; 1: alarm
100*n+20	binary	High Pressure Protection Ckt1	(0,1)	-	R	0:no alarm; 1: alarm
100*n+21	binary	Low Pressure Protection Ckt1	(0,1)	-	R	0:no alarm; 1: alarm
100*n+22	binary	Discharge Temp Protection Ckt1	(0,1)	-	R	0:no alarm; 1: alarm
100*n+23	binary	Low Superheat Ckt1	(0,1)	-	R	0:no alarm; 1: alarm
100*n+24	binary	Discharge Pressure Sensor Ckt1	(0,1)	-	R	0:no alarm; 1: alarm
100*n+25	binary	Suction Pressure Sensor Ckt1	(0,1)	-	R	0:no alarm; 1: alarm
100*n+26	binary	Refrigerant Leakage Ckt1	(0,1)	-	R	0:no alarm; 1: alarm
100*n+27	binary	Discharge Temp Sensor Ckt1	(0,1)	-	R	0:no alarm; 1: alarm
100*n+28	binary	Coil Temp Sensor Ckt1	(0,1)	-	R	0:no alarm; 1: alarm
100*n+29	binary	Suction Temp Sensor Ckt1	(0,1)	-	R	0:no alarm; 1: alarm

100*n+30	binary	High Suction Temp Ckt1	(0,1)	-	R	0:no alarm; 1: alarm
100*n+31	binary	Reserved 2	(0,1)	-	R	0:no alarm; 1: alarm
100*n+32	binary	Compressor Overload Ckt2	(0,1)	-	R	0:no alarm; 1: alarm
100*n+33	binary	Fan Overload Ckt2	(0,1)	-	R	0:no alarm; 1: alarm
100*n+34	binary	Current Abnormal Comp2A	(0,1)	-	R	0:no alarm; 1: alarm
100*n+35	binary	Current Abnormal Comp2B	(0,1)	-	R	0:no alarm; 1: alarm
100*n+36	binary	High Pressure Protection Ckt2	(0,1)	-	R	0:no alarm; 1: alarm
100*n+37	binary	Low Pressure Protection Ckt2	(0,1)	-	R	0:no alarm; 1: alarm
100*n+38	binary	Discharge Temp Protection Ckt2	(0,1)	-	R	0:no alarm; 1: alarm
100*n+39	binary	Low Superheat Ckt2	(0,1)	-	R	0:no alarm; 1: alarm
100*n+40	binary	Discharge Pressure Sensor Ckt2	(0,1)	-	R	0:no alarm; 1: alarm
100*n+41	binary	Suction Pressure Sensor Ckt2	(0,1)	-	R	0:no alarm; 1: alarm
100*n+42	binary	Refrigerant Leakage Ckt2	(0,1)	-	R	0:no alarm; 1: alarm
100*n+43	binary	Discharge Temp Sensor Ckt2	(0,1)	-	R	0:no alarm; 1: alarm
100*n+44	binary	Coil Temp Sensor Ckt2	(0,1)	-	R	0:no alarm; 1: alarm
100*n+45	binary	Suction Temp Sensor Ckt2	(0,1)	-	R	0:no alarm; 1: alarm
100*n+46	binary	High Suction Temp Ckt2	(0,1)	-	R	0:no alarm; 1: alarm
100*n+47	binary	Reserved 3	(0,1)	-	R	0:no alarm; 1: alarm
100*n+48	binary	High Bus Voltage Ckt1-Fan1	(0,1)	-	R	0:no alarm; 1: alarm
100*n+49	binary	Low Bus Voltage Ckt1-Fan1	(0,1)	-	R	0:no alarm; 1: alarm
100*n+50	binary	High IPM Temp Ckt1-Fan1	(0,1)	-	R	0:no alarm; 1: alarm
100*n+51	binary	High Output Power Ckt1-Fan1	(0,1)	-	R	0:no alarm; 1: alarm
100*n+52	binary	Other Protection Ckt1-Fan1	(0,1)	-	R	0:no alarm; 1: alarm
100*n+53	binary	High Bus Voltage Ckt1-Fan2	(0,1)	-	R	0:no alarm; 1: alarm
100*n+54	binary	Low Bus Voltage Ckt1-Fan2	(0,1)	-	R	0:no alarm; 1: alarm
100*n+55	binary	High IPM Temp Ckt1-Fan2	(0,1)	-	R	0:no alarm; 1: alarm
100*n+56	binary	High Output Power Ckt1-Fan2	(0,1)	-	R	0:no alarm; 1: alarm
100*n+57	binary	Other Protection Ckt1-Fan2	(0,1)	-	R	0:no alarm; 1: alarm
100*n+58	binary	Comm Loss	(0,1)	-	R	0:no alarm; 1: alarm
100*n+59	binary	Eco Inlet Rfgt Temp Ckt1	(0,1)	-	R	0:no alarm; 1: alarm
100*n+60	binary	Eco Outlet Rfgt Temp Ckt1	(0,1)	-	R	0:no alarm; 1: alarm
100*n+61	binary	Eco Inlet Rfgt Temp Ckt2	(0,1)	-	R	0:no alarm; 1: alarm
100*n+62	binary	Eco Outlet Rfgt Temp Ckt2	(0,1)	-	R	0:no alarm; 1: alarm
100*n+63	binary	High Bus Voltage Ckt2-Fan1	(0,1)	-	R	0:no alarm; 1: alarm
100*n+64	binary	Low Bus Voltage Ckt2-Fan1	(0,1)	-	R	0:no alarm; 1: alarm
100*n+65	binary	High IPM Temp Ckt2-Fan1	(0,1)	-	R	0:no alarm; 1: alarm
100*n+66	binary	High Output Power Ckt2-Fan1	(0,1)	-	R	0:no alarm; 1: alarm
100*n+67	binary	Other Protection Ckt2-Fan1	(0,1)	-	R	0:no alarm; 1: alarm
100*n+68	binary	High Bus Voltage Ckt2-Fan2	(0,1)	-	R	0:no alarm; 1: alarm

100*n+69	binary	Low Bus Voltage Ckt2-Fan2	(0,1)	-	R	0:no alarm; 1: alarm
100*n+70	binary	High IPM Temp Ckt2-Fan2	(0,1)	-	R	0:no alarm; 1: alarm
100*n+71	binary	High Output Power Ckt2-Fan2	(0,1)	-	R	0:no alarm; 1: alarm
100*n+72	binary	Other Protection Ckt2-Fan2	(0,1)	-	R	0:no alarm; 1: alarm
100*n+73	binary	AFD Over Current Ckt1	(0,1)	-	R	0:no alarm; 1: alarm
100*n+74	binary	AFD Over Voltage Ckt1	(0,1)	-	R	0:no alarm; 1: alarm
100*n+75	binary	AFD Under Voltage Ckt1	(0,1)	-	R	0:no alarm; 1: alarm
100*n+76	binary	AFD Overload Ckt1	(0,1)	-	R	0:no alarm; 1: alarm
100*n+77	binary	AFD Overheat Ckt1	(0,1)	-	R	0:no alarm; 1: alarm
100*n+78	binary	AFD Other Protection Ckt1	(0,1)	-	R	0:no alarm; 1: alarm
100*n+79	binary	AFD Over Current Ckt2	(0,1)	-	R	0:no alarm; 1: alarm
100*n+80	binary	AFD Over Voltage Ckt2	(0,1)	-	R	0:no alarm; 1: alarm
100*n+81	binary	AFD Under Voltage Ckt2	(0,1)	-	R	0:no alarm; 1: alarm
100*n+82	binary	AFD Overload Ckt2	(0,1)	-	R	0:no alarm; 1: alarm
100*n+83	binary	AFD Overheat Ckt2	(0,1)	-	R	0:no alarm; 1: alarm
100*n+84	binary	AFD Other Protection Ckt2	(0,1)	-	R	0:no alarm; 1: alarm
100*n+85	binary	AFD Comm Loss Ckt1	(0,1)	-	R	0:no alarm; 1: alarm
100*n+86	binary	AFD Comm Loss Ckt2	(0,1)	-	R	0:no alarm; 1: alarm

5 Alarms and Troubleshooting

Items	Alarms Description	Possible causes	Actions
1	There is no display when the controller is powered on	1) No power supply	1) Check the power supply
2	The controller cannot query the connected host	1) AB reversed	1) Recheck the wiring
3	The controller cannot query parts of connected air conditioning system	1) Duplicate address 2) Part units AB is reversed	1) check the address of each internal unit in the system 2) check the wiring
4	Part of units is lost during normal use	The centralized controller is disconnected, or the external unit is disconnected	Check whether the external unit of the centralized controller is powered off

Trane – by Trane Technologies (NYSE:TT), a global climate innovator – creates comfortable, energy efficient indoor environments for commercial and residential applications. For more information, please visit trane.com or tranetechnologies.com.

Trane has a policy of continuous product and product data improvement and reserves the right to change design and specifications without notice. We are committed to using environmentally conscious print practices.