



Installation, Operation, and Maintenance

CenTraVac™ Water-cooled Chillers

Model CVHH

With Symbio™ Controls

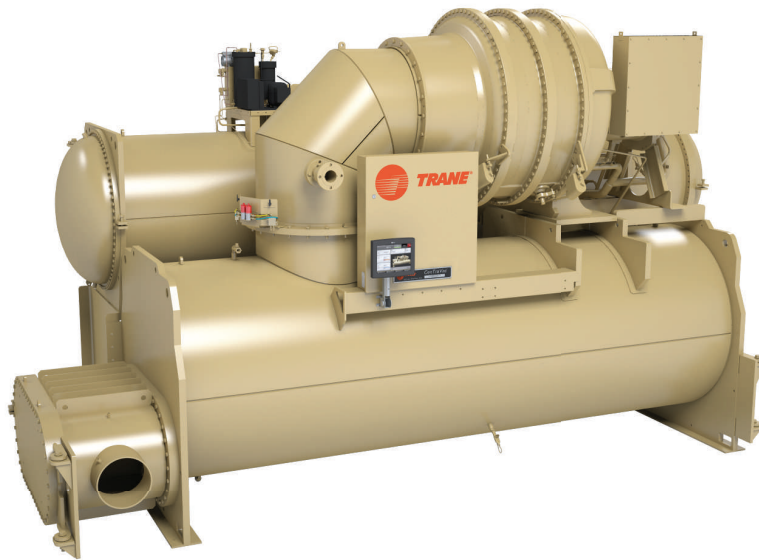

Model: CVHH

X39641417004

▲ SAFETY WARNING

Only qualified personnel should install and service the equipment. The installation, starting up, and servicing of heating, ventilating, and air-conditioning equipment can be hazardous and requires specific knowledge and training. Improperly installed, adjusted or altered equipment by an unqualified person could result in death or serious injury. When working on the equipment, observe all precautions in the literature and on the tags, stickers, and labels that are attached to the equipment.

December 2023

CVHH-SVX003D-EN

TRANE
TECHNOLOGIES™



Introduction

Read this manual thoroughly before operating or servicing this unit.

Warnings, Cautions, and Notices

Safety advisories appear throughout this manual as required. Your personal safety and the proper operation of this machine depend upon the strict observance of these precautions.

The three types of advisories are defined as follows:



Indicates a potentially hazardous situation which, if not avoided, could result in death or serious injury.



Indicates a potentially hazardous situation which, if not avoided, could result in minor or moderate injury. It could also be used to alert against unsafe practices.



Indicates a situation that could result in equipment or property-damage only accidents.

Important Environmental Concerns

Scientific research has shown that certain man-made chemicals can affect the earth's naturally occurring stratospheric ozone layer when released to the atmosphere. In particular, several of the identified chemicals that may affect the ozone layer are refrigerants that contain Chlorine, Fluorine and Carbon (CFCs) and those containing Hydrogen, Chlorine, Fluorine and Carbon (HCFCs). Not all refrigerants containing these compounds have the same potential impact to the environment. Trane advocates the responsible handling of all refrigerants.

Important Responsible Refrigerant Practices

Trane believes that responsible refrigerant practices are important to the environment, our customers, and the air conditioning industry. All technicians who handle refrigerants must be certified according to local rules. For the USA, the Federal Clean Air Act (Section 608) sets forth the requirements for handling, reclaiming, recovering and recycling of certain refrigerants and the equipment that is used in these service procedures. In addition, some states or municipalities may have additional requirements that must also be adhered to for responsible management of refrigerants. Know the applicable laws and follow them.

⚠ WARNING

Proper Field Wiring and Grounding Required!

Failure to follow code could result in death or serious injury.

All field wiring **MUST** be performed by qualified personnel. Improperly installed and grounded field wiring poses **FIRE** and **ELECTROCUTION** hazards. To avoid these hazards, you **MUST** follow requirements for field wiring installation and grounding as described in **NEC** and your local/state/national electrical codes.

⚠ WARNING

Personal Protective Equipment (PPE) Required!

Failure to wear proper PPE for the job being undertaken could result in death or serious injury.

Technicians, in order to protect themselves from potential electrical, mechanical, and chemical hazards, **MUST** follow precautions in this manual and on the tags, stickers, and labels, as well as the instructions below:

- **Before installing/servicing this unit, technicians MUST put on all PPE required for the work being undertaken (Examples; cut resistant gloves/sleeves, butyl gloves, safety glasses, hard hat/bump cap, fall protection, electrical PPE and arc flash clothing). ALWAYS refer to appropriate Safety Data Sheets (SDS) and OSHA guidelines for proper PPE.**
- **When working with or around hazardous chemicals, ALWAYS refer to the appropriate SDS and OSHA/GHS (Global Harmonized System of Classification and Labelling of Chemicals) guidelines for information on allowable personal exposure levels, proper respiratory protection and handling instructions.**
- **If there is a risk of energized electrical contact, arc, or flash, technicians MUST put on all PPE in accordance with OSHA, NFPA 70E, or other country-specific requirements for arc flash protection, PRIOR to servicing the unit. NEVER PERFORM ANY SWITCHING, DISCONNECTING, OR VOLTAGE TESTING WITHOUT PROPER ELECTRICAL PPE AND ARC FLASH CLOTHING. ENSURE ELECTRICAL METERS AND EQUIPMENT ARE PROPERLY RATED FOR INTENDED VOLTAGE.**

⚠ WARNING

Follow EHS Policies!

Failure to follow instructions below could result in death or serious injury.

- All Trane personnel must follow the company's Environmental, Health and Safety (EHS) policies when performing work such as hot work, electrical, fall protection, lockout/tagout, refrigerant handling, etc. Where local regulations are more stringent than these policies, those regulations supersede these policies.
- Non-Trane personnel should always follow local regulations.

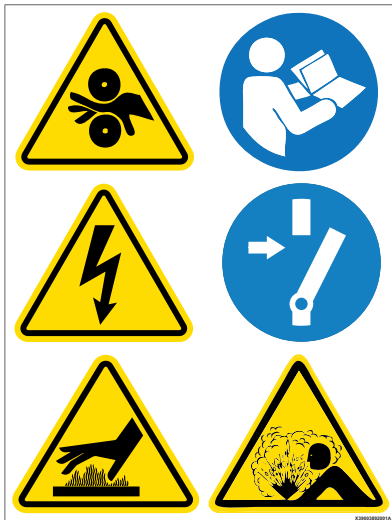

Note: Graphic labels (shown above) are used for CE application only.

Important:

- Before servicing, disconnect all power sources and allow at least 30 minutes for capacitors to discharge.
- All electrical enclosures—unit or remote—are IP2X.

⚠ WARNING

Refrigerant May Be Under Positive Pressure!

Failure to follow instructions below could result in an explosion which could result in death or serious injury or equipment damage.

System contains refrigerant and may be under positive pressure; system may also contain oil. Recover refrigerant to relieve pressure before opening the system. See unit nameplate for refrigerant type. Do not use non-approved refrigerants, refrigerant substitutes, or non-approved refrigerant additives.

⚠ WARNING

Replace Manual in Cabinet After Use!

Failure to replace this Installation, Operation, and Maintenance manual in cabinet after use could prevent personnel from accessing necessary safety information and could result in death or serious injury or equipment damage.

NOTICE

Do Not Use Non-Compatible Parts or Materials!

Use of non-compatible parts or materials could result in equipment damage.

Only genuine Trane® replacement components with identical Trane part numbers should be used in Trane CenTraVac chillers. Trane assumes no responsibility for damages resulting from the use of non-compatible parts or materials.

Factory Warranty Information

Compliance with the following is required to preserve the factory warranty:

All Unit Installations

Startup MUST be performed by Trane, or an authorized agent of Trane, to VALIDATE this WARRANTY. Contractor must provide a two-week startup notification to Trane (or an agent of Trane specifically authorized to perform startup).

Additional Requirements for Units Requiring Disassembly and Reassembly

When a new chiller is shipped and received from our Trane manufacturing location and, for any reason, it requires disassembly or partial disassembly, and reassembly—which could include but is not limited to the evaporator, condenser, control panel, compressor/motor, economizer, purge, factory-mounted starter or any other components originally attached to the fully assembled unit—compliance with the following is required to preserve the factory warranty:

- Trane, or an agent of Trane specifically authorized to perform start-up and warranty of Trane® products, will



Introduction

perform or have direct on-site technical supervision of the disassembly and reassembly work.

- The installing contractor must notify Trane—or an agent of Trane specifically authorized to perform startup and warranty of Trane® products—two weeks in advance of the scheduled disassembly work to coordinate the disassembly and reassembly work.
- Start-up must be performed by Trane or an agent of Trane specifically authorized to perform startup and warranty of Trane® products.

Trane, or an agent of Trane specifically authorized to perform start-up and warranty of Trane® products, will provide qualified personnel and standard hand tools to perform the disassembly and reassembly work at a location specified by the contractor. The contractor shall provide the rigging equipment such as chain falls, gantries, cranes, forklifts, etc. necessary for the disassembly and reassembly work and the required qualified personnel to operate the necessary rigging equipment.

Copyright

This document and the information in it are the property of Trane, and may not be used or reproduced in whole or in part without written permission. Trane reserves the right to revise this publication at any time, and to make changes to its content without obligation to notify any person of such revision or change.

Trademarks

All trademarks referenced in this document are the trademarks of their respective owners.

Factory Training

Factory training is available through Trane University™ to help you learn more about the operation and maintenance of your equipment. To learn about available training opportunities contact Trane University™.

Online: www.trane.com/traneuniversity

Phone: 855-803-3563

Email: traneuniversity@trane.com

Revision History

- Updated X code information in the cover page.
- Updated Tracer® TU topic in Installation: Controls chapter.
- Updated General Requirements topic in Operating Principles chapter.
- Updated Power Up, Hot Water Control and Daily Unit Start-up topic in Start-Up and Shutdown chapter.
- Updated Appendix E table.



Table of Contents

Unit Nameplate	8	Required Flow-Sensing Devices	30
Compressor Nameplate	9	Water Flow Detection Controller and	
Pressure Vessel Nameplates	9	Sensor – ifm efector	30
Model Number Descriptions	11	Evaporator and Condenser Water	
CVHH CenTraVac Chiller Description	11	Piping	32
CCHH Centrifugal Compressor		Water Piping Connections	33
Description	12	Waterbox Locations	33
Pre-Installation	13	Grooved Pipe Coupling	34
ASHRAE Standard 15 Compliance	13	Flange-connection Adapters	34
Unit Shipment	13	Victaulic Gasket Installation	35
General Information	13	Screw-Tightening Sequence for Water	
Installation Requirements and Contractor		Piping Connections	36
Responsibilities	14	Flanges with 8 or 12 Screws	36
Storage Requirements	15	Flanges with 16 or 20 Screws	36
Unit Components	17	Pressure Testing Waterside Piping	36
Unit Clearances and Weights	18	Eddy Current Testing	36
Recommended Unit Clearances	18	Vent Piping	37
General Weights	19	Refrigerant Vent Line	37
Weights (lb)	19	General Requirements	37
Weights (kg)	20	Purge Discharge	37
Installation: Mechanical	23	Vent Line Materials	37
Operating Environment	23	Vent Line Sizing	37
Foundation Requirements	23	Vent Line Installation	38
Rigging	23	Trane RuptureGuard	40
Standard Chiller Lift	23	General Information	40
Special Lift Requirements	25	Connection to External Vent Line and	
Unit Isolation	25	Drip Leg	40
Isolation Pads	25	Vent Line Sizing Reference	41
Spring Isolators	25	Insulation	46
Leveling the Unit	27	Unit Insulation Requirements	46
Installation: Water Piping	29	Insulation Thickness Requirements	46
Overview	29	Factory-applied Insulation	46
Water Treatment	29	Installation: Controls	48
Water Pressure Gauges	29	Symbio™ 800	48
Valves – Drains and Vents	29	AdaptiView™ Display	48
Strainers	30	Tracer TU	48
		Control Panel	49
		Installing the Tracer® AdaptiView™	
		Display	50

Adjusting the Tracer® AdaptiView™ Display Arm.....	51	System Control Circuit Wiring (Field Wiring).....	71
Module Installation.....	52	Water Pump Interlock Circuits and Flow Switch Input.....	72
Air-Fi®.....	52	Chilled Water Pump.....	73
Wi-Fi.....	53	Chilled Water Proof of Flow.....	73
Electrical Requirements.....	54	Condenser Water Pump.....	73
Installation Requirements.....	54	Condenser Water Proof of Flow.....	73
Electrical Requirements.....	54	Sensor Circuits.....	73
Trane-supplied Remote Starter Wiring.....	55	CWR – Outdoor Option.....	76
Customer-supplied Remote Starter Wiring.....	57	Optional Control and Output Circuits.....	76
Current Transformer and Potential Transformer Wire Sizing.....	58	Starter Module Configuration.....	76
Power Supply Wiring.....	59	Schematic Wiring Drawings.....	76
Three-Phase Power.....	59	Operating Principles.....	77
Circuit Breakers and Fused Disconnects.....	60	General Requirements.....	77
CE for Control Power Transformer Option.....	60	Cooling Cycle.....	77
CE for Starter or Drive.....	61	CVHH 3-Stage Compressor.....	77
Control Power Transformer Option.....	62	CVHH 2-Stage Compressor.....	77
Power Factor Correction Capacitors (Optional).....	62	Oil and Refrigerant Pump.....	78
Interconnecting Wiring.....	64	Compressor Lubrication System.....	78
Starter to Motor Wiring (Remote-Mounted Starters Only).....	65	Motor Cooling System.....	80
Ground Wire Terminal Lugs.....	65	Tracer® AdaptiView™ Display.....	80
Terminal Clamps.....	65	RuptureGuard.....	81
Wire Terminal Lugs.....	65	Operation.....	81
Bus Bars.....	66	EarthWise Purge.....	81
Starter to Control Panel Wiring.....	66	General Information.....	81
Medium Voltage Motor.....	68	Start-Up and Shutdown.....	85
Motor Terminal Box.....	68	Sequence of Operation.....	85
Motor Supply Wiring.....	69	Software Operation Overview Diagram.....	85
Motor Terminals.....	69	Start-Up Sequence of Operation— Wye-delta.....	86
Ground Wire Terminal Lug.....	70	Power Up.....	88
CE for Medium Voltage Starter.....	70	Ice Building Control.....	88
		Free Cooling Cycle.....	90
		Hot Water Control.....	91
		Control Panel Devices and Unit-Mounted Devices.....	91
		Unit Control Panel.....	91
		User-defined Language Support.....	91

Unit Start-Up and Shutdown Procedures	92	EarthWise Purge	107
Daily Unit Start-Up	92	Maintenance	107
Seasonal Unit Start-Up	93	Waterbox Removal and Installation	110
Daily Unit Shutdown	93	Discussion	110
Seasonal Unit Shutdown	93	Procedure	110
EarthWise Purge	93	Reassembly	111
Sequence of Operations	93	Torque Requirements and Waterbox	
Air Removal	97	Weights	111
Pump-out Operating Sequence	98	Screw-Tightening Sequence for	
Carbon Tank and Regeneration		Waterboxes	113
Subsystem	99	Evaporator Waterbox Covers	113
Recommended Maintenance	102	Condenser Waterbox Covers	113
Record Keeping Forms	102	Heat Recovery Condenser Waterbox	
Normal Operation	103	Covers	114
Recommended Compressor Oil		Appendix A: Forms and Check	
Change	104	Sheets	115
Purge System	104	Unit Start-Up/Commissioning	115
Leak Checking Based on Purge Pump		Appendix B: Chiller Installation Completion	
Out Time	104	and Request for Trane Service	116
Leak Testing	105	Appendix C: CenTraVac™ Chiller Start-Up	
Recommended System Maintenance	105	Tasks to be Performed by Trane	118
Condenser	106	Appendix D: CenTraVac™ Chiller Annual	
Evaporator	106	Inspection List	120
Waterbox and Tubesheet Protective		Appendix E: CVHH CenTraVac™ Chiller	
Coatings	106	Operator Log	121
Sacrificial Anodes	106		
RuptureGuard Maintenance	107		



Unit Nameplate

The unit nameplate is located on the left side of the control panel. A typical unit nameplate is illustrated in the following figure and contains the following information:

- Unit model and size descriptor
- Unit electrical requirements
- Correct operating charge and refrigerant type
- Unit test pressures and maximum operating pressures
- Unit literature

Serial Number. The unit serial number provides the specific chiller identity. Always provide this serial number when calling for service or during parts identification.

Service Model Number. The service model represents the unit as built for service purposes. It identifies the selections of variable unit features required when ordering replacements parts or requesting service.

Note: *Unit-mounted starters are identified by a separate number found on the starter.*

Product Description Block. The chiller models are defined and built using the Product Definition and Selection (PDS) system. This system describes the product offerings using a product coding block which is made up of feature categories and codes that identify all characteristics of a unit.

Figure 1. Typical unit nameplate

TRANE MADE IN USA

1 NOTIFIED BODY NO: 0496
 2 MODEL NUMBER
 CVHH120CAABL MCFCHGGF0BJ00AAG00000000AD
 3 SERIAL NO: L16K04907 S.O. NO: 06H647A
 DATE OF MANUFACTURE (DD-MM-YY): 16-01-17

LINE VOLTAGE: 400 VOLTS 50HZ 3 PH
 VOLTAGE UTILIZATION RANGE: 360- 44
 UNIT LINE CURRENT: 1049 AMPS
 MINIMUM UNIT CIRCUIT AMPACITY: 1312 AMPS
 MAX UNIT OVERCURRENT PROTECTION: 2000 AMPS
 SHORT CIRCUIT CURRENT RATING:SEE STARTER NAMEPLATE

	V/HZ/PH	RLA	LRAY	LRAD
COMPRESSOR MOTOR:	460 /60/3	972	2033	6288

VAC/HZ/PH/VA
 CONTROL PWR TRANSFORMER CKT W/O CPTR: 115/50/ 1/4000

	VAC/HZ/PH	QLA	QLR	FLA
OIL PUMP MOTOR	400/50/3	15	2.6	2.6

	QTY	VAC/HZ/PH	QLA	QLR	FLA
OIL TANK HEATER	2	115/50/1	0.75	6.25	A
CARBON TANK HEATER	1	115/50/1	.175	1.5	A
PUMPOUT COMPRESSOR	1	115/50/1	0.05	2.6	FLA
PURGE COMPR MOTOR	1	115/50/1	8	34.6	LRA

4 REFRIGERANT TYPE: 12332D E
 RECOMMENDED CHARGE: 975 KG
 FIELD CHARGE: KG
 LUBRICANT: MINERAL OIL
 FACTORY CHARGE: 79.5 L

PS LP: 3.45 BAR HP: 3.45 BAR

INSTALL, OPERATION, MAINTENANCE MANUAL:CVHH-SVX001E-EN

MANUFACTURED UNDER ONE OR MORE OF THE FOLLOWING:
 U.S. PATENTS: 6049299 6085532 6250102 6341493
 6666042 6679076 6917857 5600960 5848538 6065297
 6098422 6250101 6563287 6647736 6564564 6705100
 7158121 7088346 7020156 7202858

PRODUCT DEFINITION:

IGVA DUL2	GENR NO	PTON 996	IMP1 870	IMP2 870
TVA 1166	TRFM 3569	SRES 5960	FAMP 239	MACT 10
MODL CVHH	DSEQ AB	APTY PROC	CPTR NO	
NTON 1200	IVLT 400	IHRZ 50	VOLT 460	
HRTZ 60	CPKW 856	CRTD STD	DSOF NO	
FRAM 5000	EVSZ 160M	EVBS 1290	EVTM TECU	
EVTC 275	EVTH 25	EVPR 150	EVWC STD	
EVWP 2	EVWT NMAR	EVWA RERE	EVCO VICT	
EFLD PG	EVVF NO	EVFP TDFS	CDSZ 200M	
CTSP NONE	CDBS 1520	CDTM IECU	CDTC 256	
CDTH 28	CDPR 150	CDWC STD	CDWP 2	
CDWT NMAR	CDWA RERE	CDCO VICT	CFLD WATE	
CDVF NO	CDFP TDFS	OREV 88	ORCD 63	
AGLT CE	RCRQ NONE	GNSL NO	AH99 OUTS	
AH07 OUTS	AH7M OUTS	AH10 OUTS	AH13 OUTS	
ARCL OUTS	FTST NO	TEST AIR	TTOL AIR	
ASTT NO	ASKT NONE	OPMM PLV	INSL STD	
WCNM SNMP	LANG SPAN	SPKG EXPS	RLDV RFGD	
REFG 1233	SRTY UAFD	SRRL 1210		

Compressor Nameplate

The compressor assembly has a separate model number which is required to identify internal and external compressor parts. The model number begins with "CCHH" and the nameplate is located on the foot of the volute.

Figure 2. Compressor nameplate



Note: The serial number space on the compressor nameplate will be intentionally left blank.

Pressure Vessel Nameplates

Figure 3. ASME nameplate (all dimensions are metric)

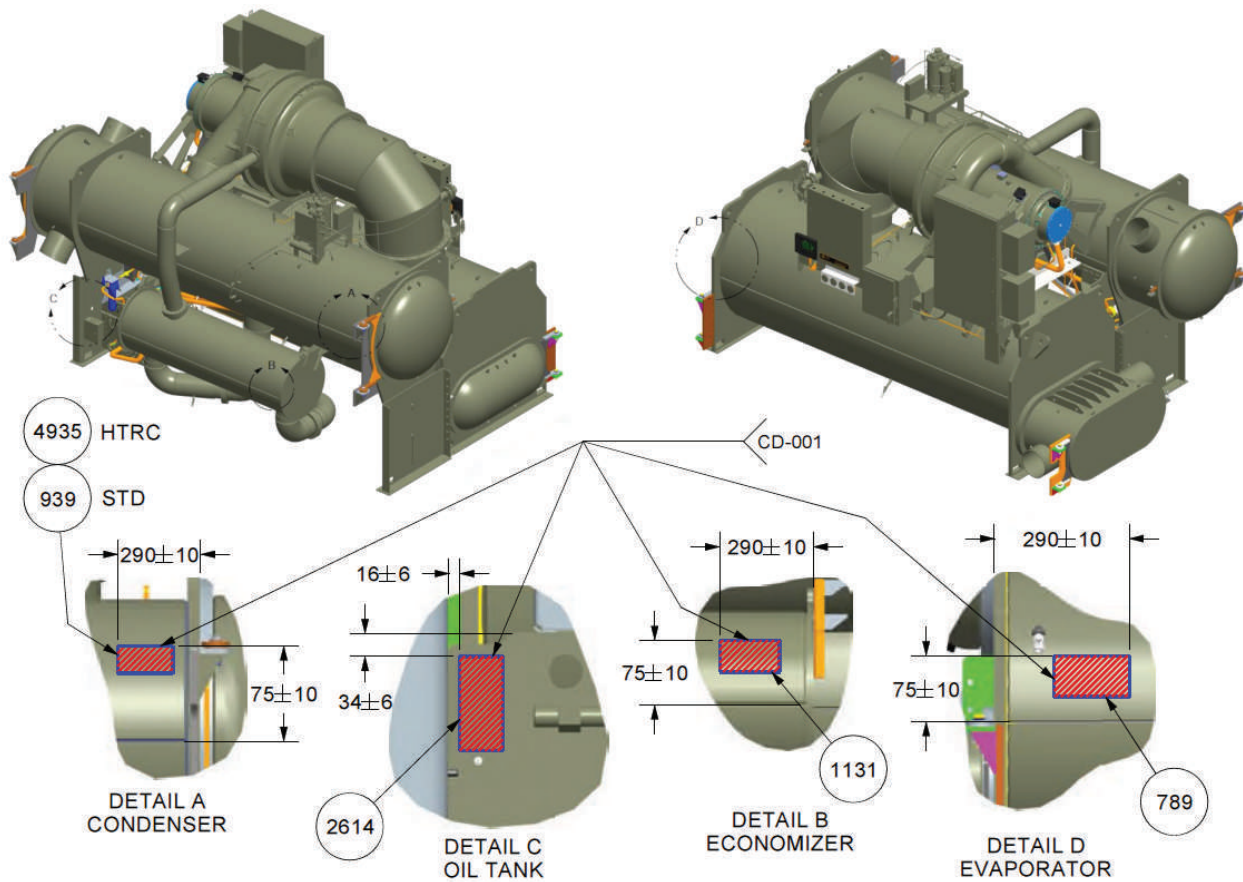
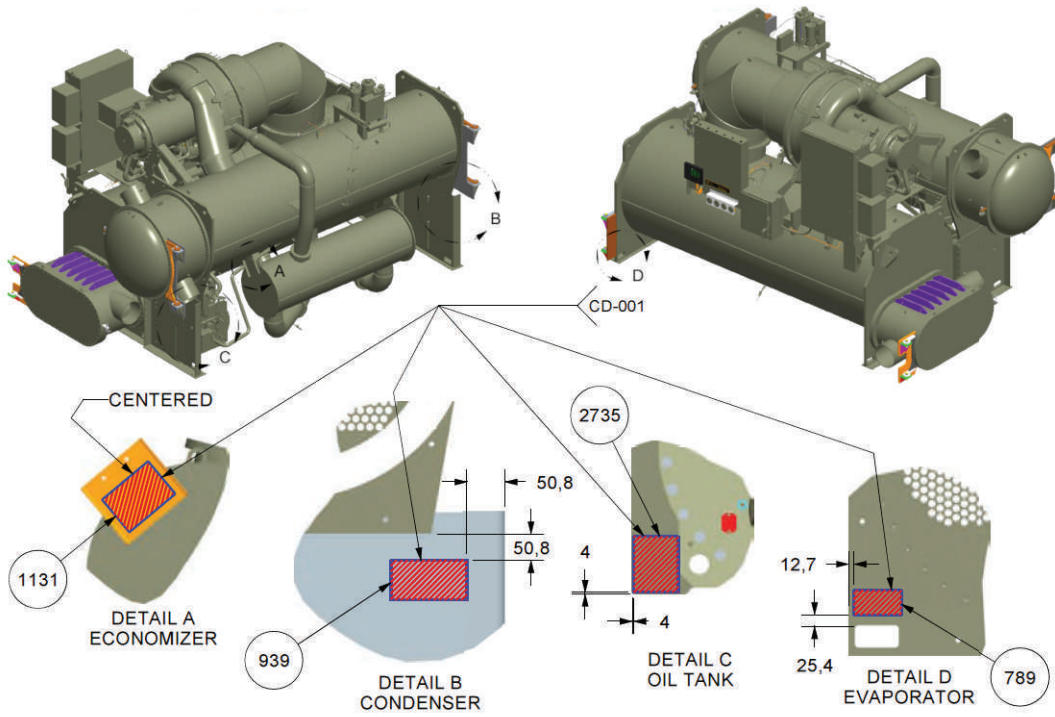

Figure 4. PED nameplate (all dimensions are metric)





Model Number Descriptions

CVHH CenTraVac Chiller Description

- | | |
|--|---|
| Digit 1, 2 — Simplex CenTraVac™ Chiller | Digit 32 — Control: Enhanced Protection |
| Digit 3 — Direct Drive | Digit 33 — Control: Extended Operation |
| Digit 4 — Development Sequence | Digit 34 — Tracer® Communication Interface |
| Digit 5, 6, 7 — Nominal Total Compressor Tonnage | Digit 35 — Special Options |
| Digit 8 — Unit Motor Voltage | Digit 36 — Control: Water Flow Control |
| Digit 9 — Unit Type | Digit 37 — Control: Chilled Water Reset |
| Digit 10, 11 — Design Sequence | Digit 38 — Control: Heat Recovery/Auxiliary Temperature Sensors |
| Digit 12 — Manufacturing Location | Digit 39 — Industrial Chiller Package (INDP) |
| Digit 13 — Hot Gas Bypass (HGB) | Digit 40 — Control Power Transformer (CPTR) |
| Digit 14 — Starter Type | Digit 41 — Thermal Dispersion Water Flow Proving |
| Digit 15 — Control Enclosure | Digit 42 — Compressor Motor Frame Size |
| Digit 16 — Evaporator Shell Size | |
| Digit 17 — Evaporator Tube Bundle | |
| Digit 18 — Evaporator Tubes | |
| Digit 19 — Evaporator Waterbox | |
| Digit 20 — Condenser Shell Size | |
| Digit 21 — Condenser Tube Bundle | |
| Digit 22 — Condenser Tubes | |
| Digit 23 — Condenser Waterbox | |
| Digit 24 — Auxiliary Condenser Size and Waterbox | |
| Digit 25, 26 — Evaporator Orifice Size | |
| Digit 27, 28 — Economizer Orifice Size | |
| Digit 29, 30 — Condenser Orifice Size | |
| Digit 31 — Unit Option | |



Model Number Descriptions

CCHH Centrifugal Compressor Description

The compressor assembly has a separate model number which is required to identify internal and external

compressor parts. The model number begins with "CCHH" and the nameplate is located on the foot of the volute.

Digit 1, 2 — Unit Function

Digit 3 — Drive

Digit 4 — Development Sequence

Digit 5, 6, 7 — Nominal Total Compressor Tonnage

Digit 8 — Compressor Motor Voltage

Digit 9 — Compressor Motor Frame Size

Digit 10, 11 — Design Sequence

Digit 12 — Manufacturing Location

Digit 13, 14, 15, 16 — Compressor Motor Power (kW)

Digit 17, 18, 19, 20 — First Stage Compressor Impeller (IMP1)

Digit 21, 22, 23, 24 — Second Stage Compressor Impeller (IMP2)

Digit 25, 26, 27, 28 — Third Stage Compressor Impeller (IMP3)

Digit 29 — Motor and Terminal Board Configuration

Digit 30 — Resistant Temperature Detector



Pre-Installation

ASHRAE Standard 15 Compliance

Trane recommends that indoor CenTraVac™ chiller installations fully meet or exceed the guidelines of the current version of ASHRAE® Standard 15, in addition to any applicable national, state, or local requirements. This typically includes:

- A refrigerant monitor or detector that is capable of monitoring and alarming within the acceptable exposure level of the refrigerant, and that can actuate mechanical ventilation.
- Audible and visual alarms, activated by the refrigerant monitor, inside the equipment room and outside of every entrance.
- The equipment room should be properly vented to the outdoors, using mechanical ventilation that can be activated by the refrigerant monitor.
- The purge discharge and the rupture disk must be properly piped to the outdoors.
- If required by local or other codes, a self-contained breathing apparatus should be available in close proximity to the equipment room.

For the USA, refer to the latest copy of ASHRAE Standard 15 for specific guidelines. Trane assumes no responsibility for any economic, health, or environmental issues that may result from an equipment room's design or function.

Unit Shipment

Inspect unit while it is still on the truck for any shipping damage. The chiller ships shrink-wrapped in a 0.010-in. (0.254 mm) recyclable film protective covering. Do NOT remove shrink-wrap for inspection! Inspect for damage to the shrink-wrap and determine if physical damage has occurred.

Each chiller ships from the factory as a hermetically assembled package; it is factory-assembled, -wired, and -tested. All openings except for the waterbox vent and drain holes are covered or plugged to prevent contamination during shipment and handling. "Unit Components," p. 17 shows an illustration of a typical unit and its components. As soon as the unit arrives at the job site, inspect it thoroughly for damage and material shortages. In addition:

1. Verify the hermetic integrity of the unit by checking the chiller pressure for an indication of holding charge pressure.
2. To prevent damaging moisture from entering the unit and causing corrosion, each chiller is pressurized with 3 to 5 psig (20.7 to 34.5 kPaG) of dry nitrogen before shipment.

Note: The holding charge should register approximately 5 psig (34.5 kPaG) at 72°F (22.2°C). Place a gauge on the access valve provided (indicated by arrow and circle in the following figure) on the refrigerant pump discharge line to verify the holding charge. This access valve is located on the front of the oil tank, which is at the right rear corner of the chiller. If the charge has escaped, contact your local Trane sales office for instructions.

3. The loose parts box and isolator pads ship on top of the control panel box.
4. Check the oil sump sight glasses to verify that the sump was factory-charged with 21 gallons (79.5 L) of oil. The oil level should be visible to about halfway in the top sight glass. If no oil level is visible, contact your local Trane sales office.

Important: If isolation springs are installed, do NOT block oil tank serviceability.

Figure 5. Refrigerant pump discharge line access valve

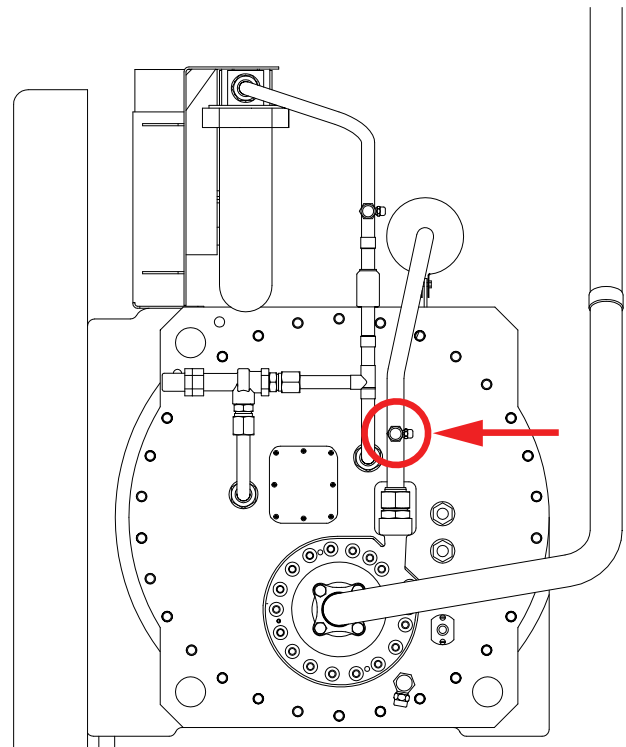

General Information

Regulations regarding waste handling are constantly changing. To ensure that personnel are in compliance with the latest local, state, and federal regulations, contact your local waste management office for the proper procedures on handling, disposal, transporting, and storage of oil, oil filters, refrigerant filters, and filter dryer cores.



Installation Requirements and Contractor Responsibilities

A list of the contractor responsibilities typically associated with the unit installation process is provided in the following table.

Notes:

1. *The chiller should remain within its protective shrink-wrap covering during storage.*
2. *These chillers are assembled with metric fasteners.*

⚠ WARNING

Combustible Material!
 Failure to follow instructions below could result in death , serious injury, or equipment damage.
 Shrink-wrap is a combustible material. Avoid open flames and hot sparks.

Type of Requirement	Trane Supplied Trane Installed	Trane Supplied Field Installed	Field Supplied Field Installed
Foundation			Meet foundation requirements
Rigging			<ul style="list-style-type: none"> Safety chains Rigging shackles Lifting beam
Disassembly/Reassembly (as required)	Trane will perform or have direct on-site supervision of the disassembly and reassembly work (contact your local Trane office for pricing)		
Isolation		Isolation pads or spring isolators	<ul style="list-style-type: none"> Isolation pads or spring isolators Optional spring isolators, when required, are installed by others; do NOT overload springs and do NOT install isolation springs if they block serviceable parts such as the oil tank system, service valves, etc.
Electrical	<ul style="list-style-type: none"> Circuit breakers or fusible disconnects (optional) Unit-mounted starter (optional) Power factor correction capacitors (PFCCs) (optional) 	<ul style="list-style-type: none"> Jumper bars Temperature sensor (optional outdoor air) Flow switches (may be field supplied); for installation instructions for the ifm efector® flow detection controller and sensor, refer to "Water Flow Detection Controller and Sensor – ifm efector," p. 30 or Trane literature that shipped with the device Remote-mounted starter (optional) Air-Fi Wi-Fi 	<ul style="list-style-type: none"> Circuit breakers or fusible disconnects (optional) Electrical connections to unit-mounted starter (optional) Electrical connections to remote-mounted starter (optional) Wiring sizes per submittal and National Electric Code (NEC) or local codes PFCCs (remote mounted starter optional only) Terminal lugs Ground connection(s) Jumper bars BAS wiring (optional) Inter-processor communication (IPC) wiring (AFD and remote-mounted starters only) Control voltage wiring (AFD and remote-mounted starters only) Oil pump interlock wiring (AFD and remote mounted starters only) High condenser pressure interlock wiring (AFD and remote-mounted starters only) Chilled water pump contactor and wiring including interlock Condenser water pump contactor and wiring including interlock Option relays and wiring

Type of Requirement	Trane Supplied Trane Installed	Trane Supplied Field Installed	Field Supplied Field Installed
Water piping		Flow sensing devices (may be field supplied)	<ul style="list-style-type: none"> • Taps for flow sensing devices • Taps for thermometers and gauges • Thermometers • Strainers (as required) • Water flow pressure gauges • Isolation and balancing valves in water piping • Vents and drain on waterbox valves (one each per pass) • Pressure relief valves (for waterboxes as required)
Relief	<ul style="list-style-type: none"> • Rupture disk assembly • RuptureGuard™ (optional) 		Vent line and flexible connector and vent line from rupture disk to atmosphere
Insulation	Insulation (optional)		<ul style="list-style-type: none"> • Insulation • Chiller feet insulation
Water Piping Connection Components	Flanged (optional)Welded on flange for 300 psig (2068.4 kPaG) waterboxes	Flanged (optional) Victaulic® to flange adapter for 150 psig (1034.2 kPaG) waterboxes	Victaulic® <ul style="list-style-type: none"> • Victaulic® coupling for 150 psig (1034.2 kPaG) and 300 psig (2068.4 kPaG) waterboxes • Fasteners for flanged-type connections (optional)
Other Materials			<ul style="list-style-type: none"> • Trace gas (1 lb [0.45 kg] maximum per machine as needed to perform leak testing) • Material and equipment to perform leak testing • Dry nitrogen (8 psig [55.2 kPaG] maximum per machine as needed)
"Appendix B: Chiller Installation Completion and Request for Trane Service," p. 116 (CTV-ADF001*-EN; refer to "Appendix A: Forms and Check Sheets," p. 115)			To be completed by installing contractor prior to contacting Trane for start-up
Chiller start-up commissioning (a)	Trane, or an agent of Trane specifically authorized to perform start-up of Trane® products		
Post-commissioning transport of empty refrigerant containers for return or recycling			Move empty refrigerant containers to an easily accessible point of loading

(a) Start-up must be performed by Trane or an agent of Trane specifically authorized to perform start-up and warranty of Trane® products. Contractor shall provide Trane (or an agent of Trane specifically authorized to perform start-up) with notice of the scheduled start-up at least two weeks prior to the scheduled start-up.

Storage Requirements

Note: If the chiller is stored outdoors for any amount of time, **do NOT remove ANY shipping coverings. Protect the chiller from the elements and protect against freezing, especially if any shipping materials have been removed.**

NOTICE

Equipment Damage!

Failure to protect the unit from freezing could result in equipment damage.

If fluid has been added to the piping, the unit must be protected from freezing. Freeze damage from an unheated equipment room is not the Trane company's responsibility. These are indoor units.

NOTICE

Insulation Damage!

Failure to follow these instructions could result in insulation damage.

To prevent damage to factory installed insulation:

- Do not allow the insulation to be exposed to excessive sunlight. Store indoors or cover with canvas to prevent exposure.
- Do not use thinners and solvents or other types of paint. Use only water base latex.



Pre-Installation

Less than 1 month	1–6 months	Greater than 6 months
Location requirements: <ul style="list-style-type: none"> • Solid foundation • Vibration free • Dry • Temperature range -40°F to 158°F (-40°C to 70°C) 	Location requirements: <ul style="list-style-type: none"> • Solid foundation • Vibration free • Dry • Temperature range -40°F to 158°F (-40°C to 70°C) 	Location requirements: <ul style="list-style-type: none"> • Solid foundation • Vibration free • Dry • Temperature range -40°F to 158°F (-40°C to 70°C)
<ul style="list-style-type: none"> • Do not remove any plastic coverings 	<ul style="list-style-type: none"> • Do not remove any plastic coverings 	<ul style="list-style-type: none"> • Do not remove any plastic coverings
<ul style="list-style-type: none"> • Do not charge the chiller with refrigerant • If additional refrigerant is on site, follow manufacturer's storage requirements 	<ul style="list-style-type: none"> • Do not charge the chiller with refrigerant • If additional refrigerant is on site, follow manufacturer's storage requirements 	<ul style="list-style-type: none"> • Do not charge the chiller with refrigerant • If additional refrigerant is on site, follow manufacturer's storage requirements
<ul style="list-style-type: none"> • Verify dry nitrogen pressure using gauge located on the evaporator shell reads 3 to 5 psig (20.7 to 34.5 kPaG) • Notify the local Trane office if charge has escaped 	<ul style="list-style-type: none"> • Verify dry nitrogen pressure using gauge located on the evaporator shell reads 3 to 5 psig (20.7 to 34.5 kPaG) • Notify the local Trane office if charge has escaped 	<ul style="list-style-type: none"> • Verify dry nitrogen pressure using gauge located on the evaporator shell reads 3 to 5 psig (20.7 to 34.5 kPaG) • Notify the local Trane office if charge has escaped
<ul style="list-style-type: none"> • Do not operate purge unit 	<ul style="list-style-type: none"> • Do not operate purge unit 	<ul style="list-style-type: none"> • Do not operate purge unit
	<ul style="list-style-type: none"> • Verify waterbox and tube bundles are clean and dry 	<ul style="list-style-type: none"> • Verify waterbox and tube bundles are clean and dry
		<ul style="list-style-type: none"> • Conduct an oil analysis and verify no oil breakdown^(a) • Repeat yearly • Replace oil if breakdown has occurred • If no oil analysis program has been followed, replace oil prior to start-up

^(a) If the chiller will be stored for more than six months after production, contact your local Trane Service Agency for *required* extended storage actions to minimize impact to the chiller and preserve the warranty.

Unit Components

Note: The control panel side of the unit is always designated as the front side of the unit.

Figure 6. Typical CVHH CenTraVac™ chiller

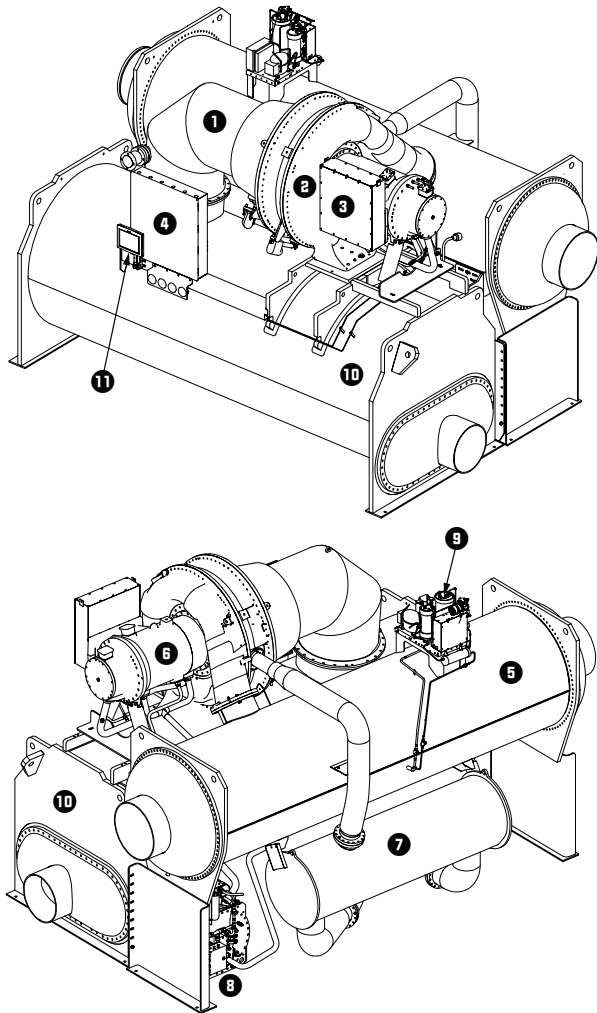

1. Suction Elbow
2. Compressor
3. Terminal Box
4. Control Panel
5. Condenser
6. Motor Housing
7. Economizer
8. Oil Tank Assembly
9. Purge
10. Evaporator
11. Display Panel

Unit Clearances and Weights

Recommended Unit Clearances

Adequate clearances around and above the chiller are required to allow sufficient access for service and maintenance operations. Specific unit clearance requirements are indicated in the submittal package provided for your unit.

- Do NOT install piping or conduit above the compressor motor assembly or behind the suction elbow of the unit.
- Minimum vertical clearance above the unit is 3 ft (92 cm).

- Use a housekeeping pad to provide better service clearances; refer to submittal for more information.

Per National Electric Code (NEC) Article 110: Unit mounted starters from 0 to 600V require a 42 inch (107 cm) clearance, 601 to 2500V require a 48 inch (122 cm) clearance, and 2501 to 9000V require a 60 inch (152 cm) clearance. Refer to NEC and local electrical codes for starter and control panel clearance requirements.

Figure 7. Clearance requirements

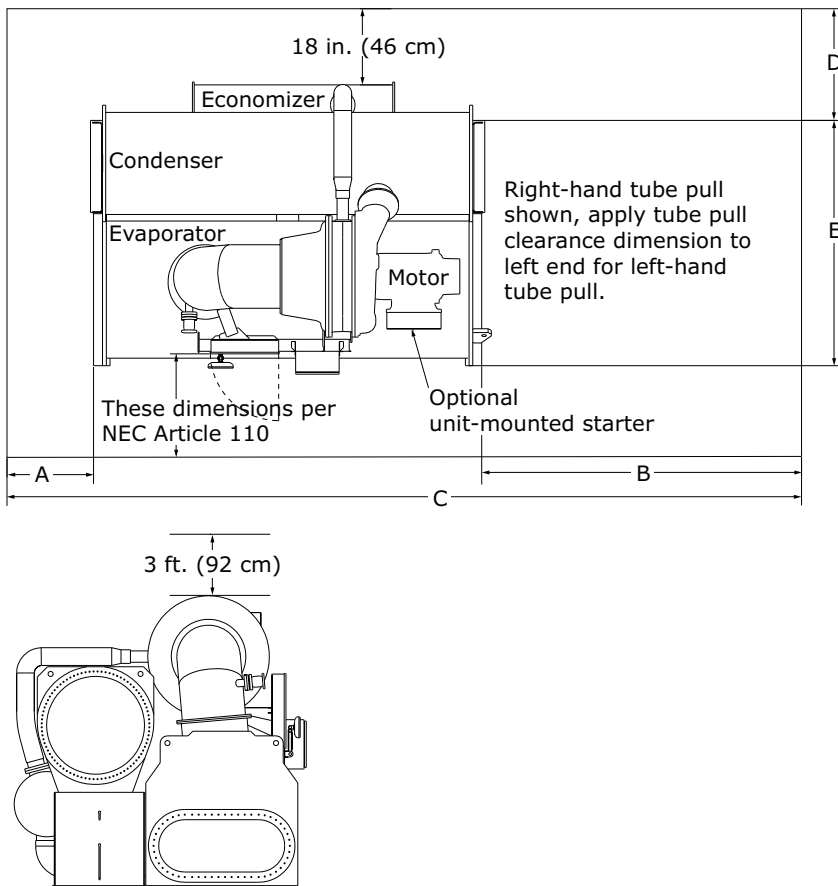

Table 1. Clearance requirements

Shell Combo	A		B		C		D		E	
	in.	cm	in.	cm	in.	cm	in.	cm	in.	cm
100M/100M	84	213	166	422	416	1057	12	30	122	310
100M/10HM	84	213	166	422	416	1057	31	79	118	300
100L/100L	84	213	186	422	457	1161	12	30	122	310
130M/130M	88	224	166	422	420	1067	29	74	109	277
130M/13HM	88	224	166	422	420	1067	31	79	123	312
160M/200M	96	244	166	422	428	1087	37	94	112	285

Table 1. Clearance requirements (continued)

Shell Combo	A		B		C		D		E	
	in.	cm	in.	cm	in.	cm	in.	cm	in.	cm
160M/20HM	96	244	166	422	428	1087	36	91	128	325
200L/200L	107	272	186	472	479	1217	34	86	111	282
200L/20HL	107	272	186	472	479	1217	37	94	131	333
200L/220L	107	272	186	472	480	1219	37	94	120	305
220L/220L	120	305	186	472	493	1252	38	97	118	300
220L/22HL	120	305	186	472	492	1250	42	107	143	363

Note: All dimensions are approximate; refer to the unit submittal package for exact dimensions for your unit.

General Weights

Weights (lb)

Important: The weight information provided here should be used for general information only. Trane does not recommend using this weight information for considerations relative to chiller handling, rigging, or placement. The large number of variances between chiller selections drives variances in chiller weights that are not recognized in these tables. For specific weights for your chiller, refer to your submittal package.

Table 2. Representative weights, 60 Hz chillers (lb)

Model	Comp Size	CPKW	Evap Size	Cond Size	Weights without Starters	
	NTON		EVSZ	CDSZ	Operating	Shipping
CVHH	900–1200	1228	100M	100M	47451	41071
	900–1200	1228	100L	100L	49252	42368
	900–1200	1340	100M	10HM	54999	47798
	900–1200	1340	130M	130M	52868	44894
	900–1200	1340	130M	13HM	62184	53398
	900–1200	1340	160M	200M	63653	53621
	900–1200	1340	200L	220L	71963	58931
	900–1200	1340	220L	220L	79082	64664
	1500–1700	1340	200L	200L	70921	59137
	1500–1700	1340	200L	20HL	80262	67562
	1500–1700	1340	220L	220L	79082	64664
	1500–1700	1340	220L	22HL	93396	78060

Notes:

1. TECU tubes, 0.028 in. tube wall thickness.
2. 300 psig marine waterboxes.
3. Heaviest possible bundle and motor combination.
4. Operating weights assume the largest possible refrigerant charge.
5. Industrial Control Panel (INDP) option, add 50 lb.
6. Control Power Transformer (CPTR) option, add 280 lb.
7. Supplemental Motor Protection (SMP) option, add 500 lb.
8. To calculate the maximum chiller weight with starter/drive, add the starter/AFD weight from the following table (maximum weights, unit-mounted starters/AFDs [lb]) to the chiller maximum weight from this table.



Unit Clearances and Weights

Table 3. Representative weights, 50Hz chillers (lb)

Model	Comp Size	CPKW	Evap Size	Cond Size	Weights without Starters	
	NTON		EVSZ	CDSZ	Operating	Shipping
CVHH	950–1050	1023	100M	100M	49024	42643
	950–1050	1023	100L	100L	50824	43940
	950–1050	1023	100M	10HM	56723	49522
	950–1050	1023	130M	130M	54592	46618
	950–1050	1023	130M	13HM	63908	55122
	950–1050	1023	160M	200M	65377	55345
	950–1050	1023	200L	220L	73687	60655
	950–1050	1023	220L	220L	80806	66388
	1550	1023	200L	200L	72345	60561
	1550	1023	200L	20HL	81686	68986
	1550	1023	220L	220L	80506	66088
	1550	1023	220L	22HL	94820	79484

Notes:

1. TECU tubes, 0.028 in. tube wall thickness.
2. 300 psig marine waterboxes.
3. Heaviest possible bundle and motor combination.
4. Operating weights assume the largest possible refrigerant charge.
5. Industrial Control Panel (INDP) option, add 50 lb.
6. Control Power Transformer (CPTR) option, add 280 lb.
7. Supplemental Motor Protection (SMP) option, add 500 lb.
8. To calculate the maximum chiller weight with starter/drive, add the starter/AFD weight from the following table (maximum weights, unit-mounted starters/AFDs [lb]) to the chiller maximum weight from this table.

Table 4. Maximum weights, unit-mounted starters/Adaptive Frequency™ Drives (AFDs) (lb)

Low Voltage (less than 600 volts)	Wye-delta	557
Adaptive Frequency Drive (less than 600 volts)	900 amp	3000
	1210 amp	3000
Medium Voltage (2300–6600 volts)	Across-the-line	652
	Primary Reactor	1602
	Autotransformer	1702

Note: All weights are nominal and ±10%.

Weights (kg)

Important: *The weight information provided here should be used for general information only. Trane does not recommend using this weight information for considerations relative to chiller handling, rigging, or placement. The large number of variances between chiller selections drives variances in chiller weights that are not recognized in these tables. For specific weights for your chiller, refer to your submittal package.*

Table 5. Representative weights, 60 Hz chillers (kg)

Model	Comp Size	CPKW	Evap Size	Cond Size	Weights without Starters	
	NTON		EVSZ	CDSZ	Operating	Shipping
CVHH	900–1200	1228	100M	100M	21523	18629
	900–1200	1228	100L	100L	22340	19218
	900–1200	1340	100M	10HM	24947	21681
	900–1200	1340	130M	130M	23981	20364
	900–1200	1340	130M	13HM	28206	24221
	900–1200	1340	160M	200M	28873	24322
	900–1200	1340	200L	220L	32642	26731
	900–1200	1340	220L	220L	35871	29331
	1500–1700	1340	200L	200L	32169	26824
	1500–1700	1340	200L	20HL	36406	30646
	1500–1700	1340	220L	220L	35871	29331
	1500–1700	1340	220L	22HL	42364	35407

Notes:

1. TECU tubes, 0.71 mm tube wall thickness.
2. 2068.4 kPaG marine waterboxes.
3. Heaviest possible bundle and motor combination.
4. Operating weights assume the largest possible refrigerant charge.
5. Industrial Control Panel (INDP) option, add 23 kg.
6. Control Power Transformer (CPTR) option, add 127 kg.
7. Supplemental Motor Protection (SMP) option, add 227 kg.
8. To calculate the maximum chiller weight with starter/drive, add the starter/AFD weight from the following table (maximum weights, unit-mounted starters/AFDs [kg]) to the chiller maximum weight from this table.

Table 6. Representative weights, 50 Hz chillers (kg)

Model	Comp Size	CPKW	Evap Size	Cond Size	Weights without Starters	
	NTON		EVSZ	CDSZ	Operating	Shipping
CVHH	950–1050	1023	100M	100M	22237	19343
	950–1050	1023	100L	100L	23053	19931
	950–1050	1023	100M	10HM	25729	22463
	950–1050	1023	130M	130M	24763	21146
	950–1050	1023	130M	13HM	28988	25003
	950–1050	1023	160M	200M	29655	25104
	950–1050	1023	200L	220L	33424	27513
	950–1050	1023	220L	220L	36653	30113
	1550	1023	200L	200L	32815	27470
	1550	1023	200L	20HL	37052	31292
	1550	1023	220L	220L	36517	29977
	1550	1023	220L	22HL	43010	36053

Notes:

1. TECU tubes, 0.71 mm tube wall thickness.
2. 2068.4 kPaG marine waterboxes.
3. Heaviest possible bundle and motor combination.
4. Operating weights assume the largest possible refrigerant charge.
5. Industrial Control Panel (INDP) option, add 23 kg.
6. Control Power Transformer (CPTR) option, add 127 kg.
7. Supplemental Motor Protection (SMP) option, add 227 kg.
8. To calculate the maximum chiller weight with starter/drive, add the starter/AFD weight from the following table (maximum weights, unit-mounted starters/AFDs [kg]) to the chiller maximum weight from this table.



Unit Clearances and Weights

Table 7. Maximum weights, unit-mounted starters/Adaptive Frequency™ Drives (AFD) (kg)

Low Voltage (less than 600 volts)	Wye-delta	253
Adaptive Frequency Drive (less than 600 volts)	900 amp	1361
	1210 amp	1361
Medium Voltage (2300–6600 volts)	Across-the-line	296
	Primary Reactor	727
	Autotransformer	772

Note: All weights are nominal and $\pm 10\%$.



Installation: Mechanical

Operating Environment

Important:

- The standard chiller is designed for **INDOOR USE ONLY** and as such has NEMA Type 1 or IP 20 enclosures.
- For chillers in unheated equipment rooms, contact your local Trane Service Agency for methods to ensure that the oil temperature is maintained suitable for proper operation of the chiller.

NOTICE

Equipment Damage!

Failure to protect the unit from freezing could result in equipment damage.

If fluid has been added to the piping, the unit must be protected from freezing. Freeze damage from an unheated equipment room is not the Trane company's responsibility. These are indoor units.

NOTICE

Equipment Failure!

Unit operating at ambient temperatures exceeding 104°F (40°C) could result in AFD/starter component damage due to the panel's inability to dissipate heat adequately.

If any of these adverse operating conditions are present, take necessary action to improve the equipment room environment.

To ensure that electrical components operate properly, do NOT locate the chiller in an area exposed to dust, dirt, corrosive fumes, or excessive heat and humidity. The ambient temperature range for chiller operation is 34°F to 104°F (1.1°C to 40°C).

Foundation Requirements

Chiller mounting surface must be:

- Rigid non-warping mounting pads or a concrete foundation, and
- Able to support the chiller at its full operating weight (including completed piping and full operating charges of refrigerant, oil, and water).

For proper unit operation, the chiller must be level within 1/16 in. (1.6 mm) over its length and width when set into place on the mounting surface. Refer to “[Leveling the Unit](#),” p. 27 for more information. For approximate weights for various chiller sizes and options in pounds and kilograms, refer to “[Weights \(lb\)](#),” p. 19 and “[Weights \(kg\)](#),” p. 20, respectively.

Note: For specific weight information, refer to the unit submittal package.

Important: Trane will not assume responsibility for equipment problems resulting from an improperly designed or constructed foundation.

Rigging

Lifting is the recommended method for moving chillers. Suggested lifting arrangements for standard units are described in “[Standard Chiller Lift](#),” p. 23.

Note: The lifting beam used for CenTraVac™ chillers must be at least 15 ft (4.6 m) long.

⚠ WARNING

Heavy Object!

Failure to follow instructions below could result in unit dropping which could result in death or serious injury, and equipment or property-only damage.

Ensure that all the lifting equipment used is properly rated for the weight of the unit being lifted. Each of the cables (chains or slings), hooks, and shackles used to lift the unit must be capable of supporting the entire weight of the unit. Lifting cables (chains or slings) may not be of the same length. Adjust as necessary for even unit lift.

NOTICE

Wiring Damage!

Damage to unit wiring could result in equipment failure.

Care must be taken during rigging, assembly and disassembly to avoid damaging unit wiring.

Standard Chiller Lift

⚠ WARNING

Proper Diameter Clevis Required to Lift Units!

Failure to follow instructions below could result in death or serious injury.

A clevis with a 2.25-in. (5.72-cm) diameter pin **MUST** be used to lift these units. Using a smaller clevis would cause too much stress to the 2.25-in. (5.72-cm) lifting holes which could result in pull-out of the lifting holes causing the unit to drop from the rigging.

1. Insert rigging shackles at the points indicated in the following figure. A 1.25 in. (31.8 mm) diameter lifting hole is provided at each of these points.
2. Attach the lifting chains or cables.
3. After the lifting cables are in place, attach a safety chain or cable between the first-stage casing of the compressor and the lifting beam.

Installation: Mechanical

Important: There should NOT be tension on this safety cable; the cable is used only to prevent the unit from rolling during the lift.

4. Position isolator pads or spring isolators beneath the chiller feet (refer to “Unit Isolation,” p. 25 for instructions). Follow instructions provided by the spring isolator manufacturer, being careful to not damage isolator adjustment screw.

5. Once the isolators are in place, lower the chiller—working from end to end—in small increments to maintain stability.
6. When lift is complete, detach the rigging shackles and safety chain.

Figure 8. Typical rigging arrangements

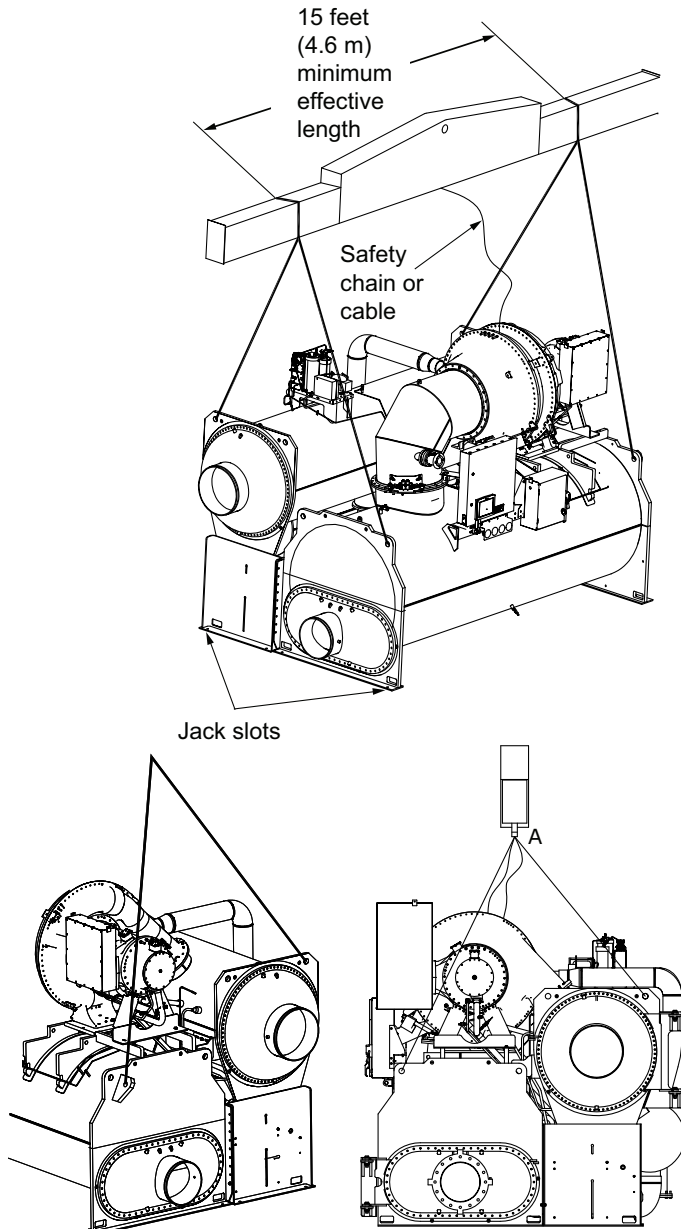

Note: Use lifting lug if present.

Special Lift Requirements

NOTICE

Oil Loss!

Failure to prevent oil migration out of the oil tank could result in equipment failure or property-only damage.

To prevent oil migration out of the oil tank during lifting procedures, remove the oil from the oil tank if the unit will be lifted at any angle greater than 15° from horizontal end-to-end. If oil is allowed to run out of the oil tank into other areas of the chiller, it will be extremely difficult to return the oil to the oil tank even during operation.

NOTICE

Equipment Damage!

Moving the chiller using a fork lift could result in equipment or property-only damage.

Do not use a fork lift to move the chiller!

NOTICE

Compressor Alignment!

Failure to preserve compressor alignment could result in equipment or property-only damage.

Lifting the compressor/motor assembly from the shells without factory-installed doweling in the compressor casting flanges could result in misalignment of the compressor castings.

If the chiller cannot be moved using a standard chiller lift, consider the following:

- When job site conditions require rigging of the chiller at an angle greater than 45° from horizontal (end-to-end), the unit may require removal of the compressor. Contact Trane or an agent of Trane specifically authorized to perform start-up and warranty of Trane® products regarding the disassembly and reassembly work. For more information, refer to “Factory Warranty Information,” p. 3.

Note: Disassembly and reassembly work includes dowel-pinning the compressor and removing it from the unit. Contact Trane or an agent of Trane specifically authorized to perform start-up and warranty of Trane® products for specific rigging instructions. Do NOT attempt to rotate the chiller onto its side.

- When lifting the chiller is either impractical or undesirable, attach cables or chains to the jacking slots shown in the figure in “Standard Chiller Lift,” p. 23; then push or pull the unit across a smooth surface. Should the chiller be on a shipping skid, it is not necessary to remove the skid from the chiller before moving it into place.
- If removal of the compressor or economizer assembly is necessary to move the chiller to the operating

location, contact Trane. Also refer to “Factory Warranty Information,” p. 3.

Unit Isolation

To minimize sound and vibration transmission through the building structure and to ensure proper weight distribution over the mounting surface, always install isolation pads or spring isolators under the chiller feet.

Note: Isolation pads (refer to the figure in “Isolation Pads,” p. 25) are provided with each chiller unless spring isolators are specified on the sales order.

Specific isolator loading data is provided in the unit submittal package. If necessary, contact your local Trane sales office for further information.

Important: When determining placement of isolation pads or spring isolators, remember that the control panel side of the unit is always designated as the front side of the unit.

Isolation Pads

When the unit is ready for final placement, position isolation pads (18-in. [457.2-mm] sides) end for end under the full length of the chiller leg. The pads measure 9 in. × 18 in. (228.6 mm x 457.2 mm) and on some units there may be small gaps between pads. Pads are provided to cover entire foot.

Figure 9. Isolation pad and dimensions

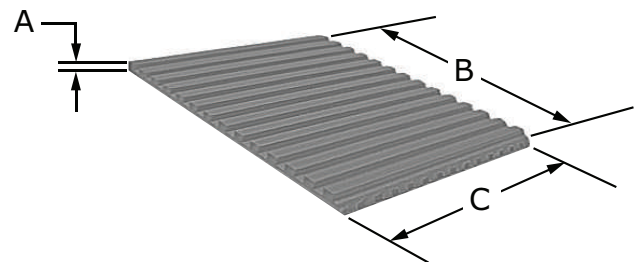

A = 3/8 in. (9.5 mm)

B = 18 in. (457.2 mm)

C = 9 in. (228.6 mm)

Remember that the chiller must be level within 1/16 in. (1.6 mm) over its length and width after it is lowered onto the isolation pads. In addition, all piping connected to the chiller must be properly isolated and supported so that it does not place any stress on the unit.

Spring Isolators

Spring isolators should be considered whenever chiller installation is planned for an upper story location. Base isolator placement is shown in the following figure; also refer to the following table.

Figure 10. Isolation spring placement

Isolator Configuration 1

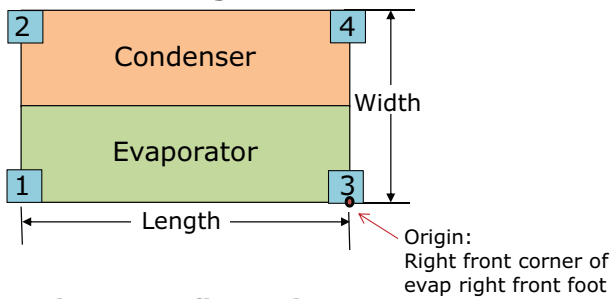

Isolator Configuration 2

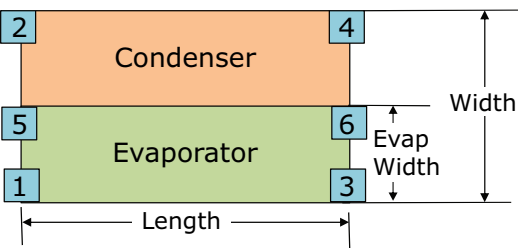

Table 8. Isolation spring placement

EVSZ	CDSZ	Width		Evap Width		Length		Isolator Config	Origin to Center of Rear Pad		Origin to Center of Middle Pad	
		in.	cm	in.	cm	in.	cm		in.	cm	in.	cm
200L	200L	112.2	285.0	67	170.2	180	457.2	2	105.7	268.5	60.5	153.7
220L	220L	119.4	303.3	74	188.0	180	457.2	2	112.9	286.8	67.5	171.5
200L	20HL	132.3	336.0	67	170.2	180	457.2	2	125.8	319.5	60.5	153.7
220L	22HL	142.5	361.0	74	188.0	180	457.2	2	136.0	345.4	67.5	171.5
160M	20HM	127.3	323.3	61	154.9	160	406.4	2	120.8	306.8	54.5	138.4
200L	220L	112.3	285.2	67	170.2	180	457.2	2	105.8	268.7	60.5	153.7
160M	200M	106.4	270.3	61	154.9	160	406.4	2	99.9	253.7	54.5	138.4
100M	100M	104.1	264.4	—	—	160	406.4	1	97.6	247.9	—	—
100L	100L	104.1	264.4	—	—	180	457.2	1	97.6	247.9	—	—
130M	130M	109.3	277.6	—	—	160	406.4	1	102.8	261.1	—	—
100M	10HM	118.2	300.2	—	—	160	406.4	1	111.7	283.7	—	—
130M	13HM	123.4	313.4	—	—	160	406.4	1	116.9	296.9	—	—

Spring isolators typically ship assembled and ready for installation. To install and adjust the isolators properly, follow the provided instructions.

Note: Do NOT adjust the isolators until the chiller is piped and charged with refrigerant and water.

Important: Do NOT block any serviceable components such as the lubrication system with field-installed devices such as spring isolators.

1. Position the spring isolators under the chiller as shown in the preceding figure. Ensure that each isolator is centered in relation to the tube sheet.

Note: Spring isolators shipped with the chiller may not be identical. Compare the data provided in the unit submittal package to determine proper isolator placement.

2. Set the isolators on the sub-base; shim as necessary to provide a flat, level surface at the same elevation for the end supports.

Important: Support the full underside of the isolator base plate; do NOT straddle gaps or small shims.

3. If required, screw the isolators to the floor through the slots provided, or cement the pads.

Note: Fastening the isolators to the floor is not necessary unless specified.

- If the chiller must be fastened to the isolators, insert cap screws through the chiller base and into holes drilled and tapped in the upper housing of each isolator.

Important: Do NOT allow the screws to protrude below the underside of the isolator upper housing, or interfere with the adjusting screws. An alternative method of fastening the chiller to the isolators is to cement the neoprene pads.

- Set the chiller on the isolators; refer to “Standard Chiller Lift,” p. 23. The weight of the chiller will force down the upper housing of each isolator, and could cause it to rest on the isolator’s lower housing (refer to the following figure).
- Check the clearance on each isolator. If this dimension is less than 1/4 in. (6.35 mm) on any isolator, use a wrench to turn the adjusting screw one complete revolution upward.

Note: When the load is applied to the isolators (refer to Step 5), the top plate of each isolator moves down to compress the springs until either the springs support the load or the top plate rests on the bottom housing of the isolator. If the springs are supporting the load, screwing down on the adjusting screw (refer to Step 7) will raise the chiller.

- Turn the adjusting screw on each of the remaining isolators to obtain the required minimum clearance of 1/4 in. (6.35 mm).
- Once the minimum required clearance is obtained on each of the isolators, level the chiller by turning the adjusting screw on each of the isolators on the low side of the unit. Work from one isolator to the next.

Important: The chiller must be level to within 1/16 in. (1.6 mm) over its length and width, and the clearance of each isolator must be at least 1/4 in. (6.35 mm).

Figure 11. Chiller foot and isolator orientation

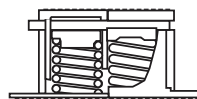
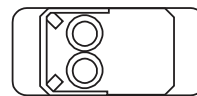
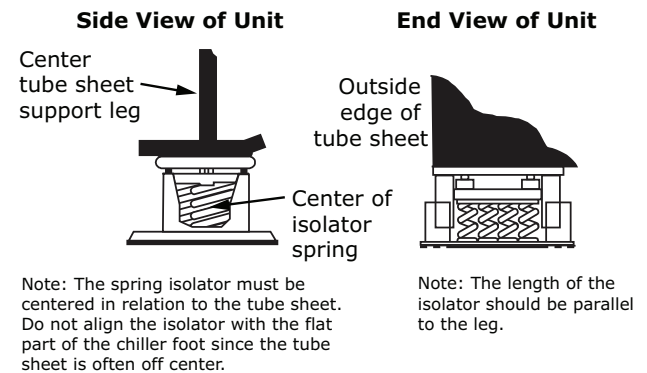

Important: Do NOT install spring isolators or brackets in such a way that they could inhibit chiller servicing such as charging or evacuation, oil tank service, etc.

Leveling the Unit

The chiller must be set level within 1/16 in. (1.6 mm).

- Measure and make a punch mark an equal distance up from the bottom of each foot of the chiller.
- Suspend a clear plastic tube along the length of the chiller as shown in the following figure.
- Fill the tube with water until the level aligns with the punch mark at one end of the chiller.
- Check the water level at the opposite mark. If the water level does not align with the punch mark, use full length shims to raise one end of the chiller until the water level at each end of the tube aligns with the punch marks at both ends of the chiller.
- Once the unit is level across its length, repeat the first three steps to level the unit across its width.



Installation: Mechanical

Figure 12. Leveling the chiller

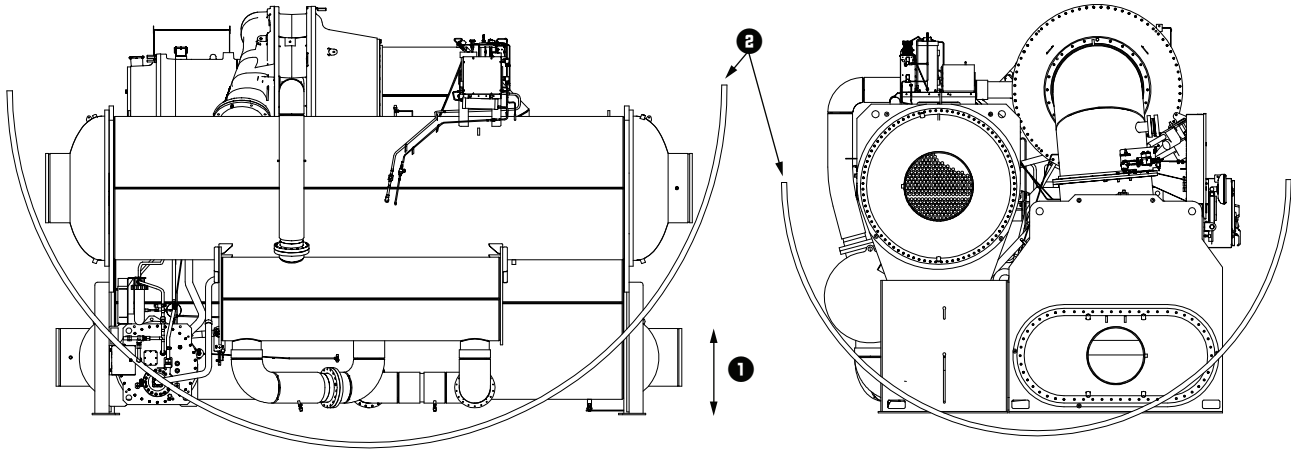

Note: Use of a laser level is an acceptable alternative method to level the unit.

Important: Immediately report any unit damage incurred during handling or installation at the job site to the Trane sales office.



Installation: Water Piping

Overview

The following water piping circuits must be installed and connected to the chiller:

- Pipe the evaporator into the chilled water circuit.
- Pipe the condenser into the cooling tower water circuit.
- *Optional:* A heat-recovery condenser water circuit.
- *Optional:* An auxiliary condenser water circuit.

Note: Piping must be arranged and supported to avoid stress on the equipment. It is strongly recommended that the piping contractor does not run pipe closer than 3 ft (0.9 m) minimum to the equipment. This will allow for proper fit upon arrival of the unit at the job site. Any adjustment that is necessary can be made to the piping at that time. Expenses that result from a failure to follow this recommendation will NOT be paid by Trane.

Piping suggestions for each of the water circuits listed above are outlined in “Evaporator and Condenser Water Piping,” p. 32. General recommendations for the installation of field-supplied piping components (e.g., valves, flow switches, etc.) common to most chiller water circuits are listed in the following sections.

Water Treatment

The use of untreated or improperly treated water in a CenTraVac™ chiller may result in inefficient operation and possible tube damage.

Important: Trane strongly recommends using the services of a qualified water treatment specialist to determine necessary water treatment. A label with a customer disclaimer note is affixed to each unit.

NOTICE

Proper Water Treatment Required!

The use of untreated or improperly treated water could result in scaling, erosion, corrosion, algae or slime.

Use the services of a qualified water treatment specialist to determine what water treatment, if any, is required. Trane assumes no responsibility for equipment failures which result from untreated or improperly treated water, or saline or brackish water.

Water Pressure Gauges

Locate pressure gauge taps in a straight length of pipe. Place each tap a minimum of one pipe diameter downstream of any elbow, orifice, etc. For example, for a 6 in. (16 cm) pipe, the tap would be at least 6 in. (16 cm) from any elbow, orifice, etc.

Valves – Drains and Vents

NOTICE

Waterbox Damage!

Failure to follow instructions could result in damage to the waterbox.

Do not over-tighten or use excessive Teflon® pipe tape when installing valves, drains, plugs and vents on waterboxes.

1. Install field-supplied air vents and drain valves on the waterboxes. Each waterbox is provided with a NPTF vent and drain connection; the openings are 3/4 in. (19.05mm).

NOTICE

Waterbox Damage!

Failure to follow instructions could result in damage to the waterbox due to hydrostatic expansion.

Install pressure-relief valves in the condenser and evaporator water circuits.

NOTICE

Equipment Damage!

Failure to follow instructions could result in equipment damage.

Do NOT allow chiller to freeze! Bundles must be drained and air-blown dry if chiller is stored in an unheated equipment room.

2. If necessary for the application, install pressure-relief valves at the drain connections on the evaporator and condenser waterboxes. To do so, add a tee with the relief valve attached to the drain valve. Follow local codes for determining if drain connection is large enough for relief devices.

To determine whether or not pressure relief valves are needed for a specific application, keep in mind that:

- a. Vessels with close-coupled shutoff valves may cause high potentially damaging hydrostatic pressures as fluid temperature rises.
- b. Relief valves are required by American Society of Mechanical Engineers (ASME) codes when the waterside is ASME. Follow ASME guidelines or other applicable codes/local regulation to ensure proper relief valve installation.

Strainers

NOTICE

Water Borne Debris!

To prevent components damage, pipe strainers must be installed in the water supplies to protect components from water borne debris. Trane is not responsible for equipment-only-damage caused by water borne debris.

Install a strainer in the entering side of each piping circuit to avoid possible tube plugging in the chiller with debris.

Required Flow-Sensing Devices

The ifm efector® flow detection controller and sensor (refer to “Water Flow Detection Controller and Sensor – ifm efector,” p. 30) is used to verify evaporator and condenser water flows.

If a customer-supplied flow sensing device is used to ensure adequate chiller flow protection, refer to the wiring diagrams that shipped with the unit for specific electrical connections.

Be sure to follow the manufacturer’s recommendations for device selection and installation.

Water Flow Detection Controller and Sensor – ifm efector

Important: Before installing the ifm efector® flow detection controller and sensor, use a marker to draw a line on the probe at 3.5 in. (8.9 cm) from the end of the probe. Do NOT insert more than 3.5 in. (8.9 cm) of the probe length into the pipe. Refer to the following figure.

Figure 13. Installation of ifm efector flow detection controller and sensor

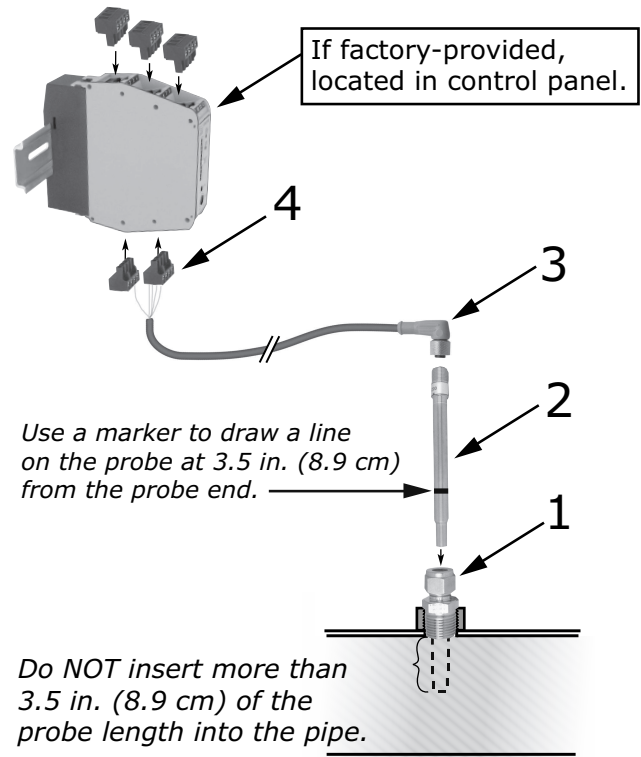

1. Mount the 1/2-in. NPT adapter in a horizontal or vertical section of pipe. The maximum distance from the control panel must not exceed 29.5 ft (9 m) (see item labeled “1” in the preceding figure). Allow at least five pipe diameters straight run of pipe upstream of the sensor location, and three pipe diameters straight run of pipe downstream of the sensor location.

Note: In the case of a horizontal pipe, mounting the sensor in the side of the pipe is preferred. In the case of a vertical pipe, mounting the sensor in a place where the water flows upwards is preferred.

NOTICE

Overtightening!

Do not exceed torque specifications as it could result in equipment damage.

2. Insert the flow sensor probe (see item labeled “2” in the preceding figure) through the 1/2-in. NPT adapter so that 3 to 3.5 in. (7.6 to 8.9 cm) of the probe’s length extends into the pipe. Tighten the 1/2-in. NPT adapter as needed to prevent leakage and keep the probe from backing out under pressure. **Do NOT exceed 40 ft·lb (54.2 N·m) of torque on the fitting. Sensor damage can occur if it is overtightened.**

Note: When installed, the tip of the ifm efector® sensor probe must be at least 1 in. (2.54 cm) away from any pipe wall. Do NOT insert more than 3.5 in. (8.9 cm) of the probe length into the pipe.

3. Install the Micro DC Cable by inserting it through the wire openings on the back side of the control panel (see item labeled “3” in the preceding figure). Install the supplied Micro DC Cable (29.5 ft [9 m] in length) to the Flow Probe and hand-tighten the connector nut.
4. Plug the other end of the Micro DC Cable into the Flow Control Monitor with the Combicon connector (see item labeled “4” in the preceding figure). Refer to the following figure for cable wiring.

5. Apply power to the chiller control panel to verify the Flow Control Monitor has power and the Low Volt Broken Wire Relay light is NOT lit.
6. Remove all air from the piping circuit prior to adjusting the low water flow setpoint.
7. Reduce the water flow to the minimum allowable flow and adjust the Flow setting on the Flow Control Monitor (see item labeled “7” in the following figure). Adjusting the “Flow” potentiometer clockwise (+) reduces the flow setting cutout and adjusting counterclockwise (-) increases the flow setting cutout.

Note: The “Temp” potentiometer on the ifm efector® control module has no effect in Trane application. It is NOT necessary to make adjustments to the “Temp” potentiometer.

8. After the cutout setting is adjusted, the cutout setpoint will be indicated with a yellow light on the Flow Control Monitor LED bar graph display. When the water flows are higher than the cutout, a green light will indicate proper flow status. If the flows fall below the cutout setpoint, a red light will indicate low/no flow status.

NOTICE

Do Not Apply Electrical Power to a Unit in a Vacuum!

Failure to follow instructions below could result in motor and compressor damage.

Do not apply electrical power to a motor in a vacuum.

For units with inside-the-delta solid state starters, disconnect power to unit during evacuation or when the unit is in a deep vacuum. In addition, on units with inside-the-delta solid state starters, all power to the unit must be disconnected prior to evacuating the unit as line power is directly applied to the motor terminals 4, 5, and 6.

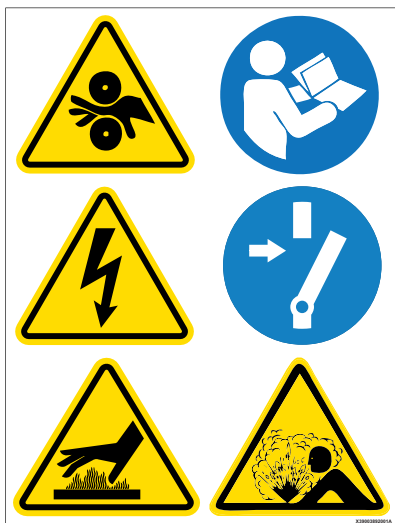

Note: Graphic labels (shown above) are used for CE application only.

Important:

- Before servicing, disconnect all power sources and allow at least 30 minutes for capacitors to discharge.
- All electrical enclosures—unit or remote—are IP2X.

Figure 14. ifm efector® flow sensing device terminal connection

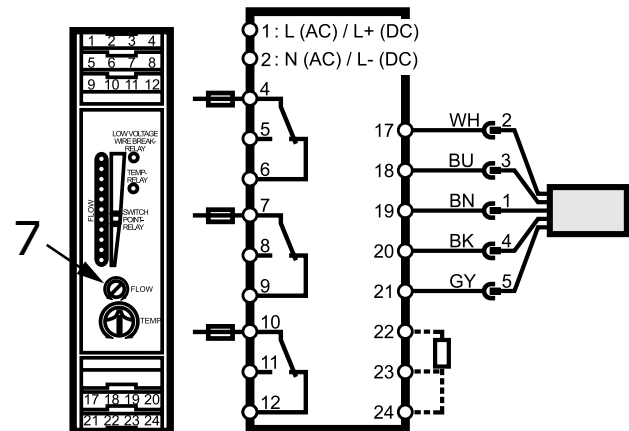

NOTICE

Proof of Flow Switch!

Failure to provide flow switches or jumping-out of switches could result in severe equipment damage. Evaporator and condenser water circuits require proof of flow switches.

- Failure to include the proof of flow devices and/or jumping out these devices could cause the unit to stop on a secondary level of protection.
- Frequent cycling on these higher level diagnostic devices could cause excessive thermal and pressure cycling of unit components (O-rings, gaskets, sensors, motors, controls, etc.) and/or freeze damage, resulting in premature failure of the chiller.

Evaporator and condenser proof of flow switches are required. These switches are used with control logic to

Installation: Water Piping

confirm flow prior to starting a unit and to stop a running unit if flow is lost. For troubleshooting, a viewable diagnostic is generated if a proof of flow switch does not close when flow is required.

Evaporator and Condenser Water Piping

The following two figures illustrate the recommended (typical) water piping arrangements for the evaporator and condenser.

Figure 15. Typical evaporator water piping circuit

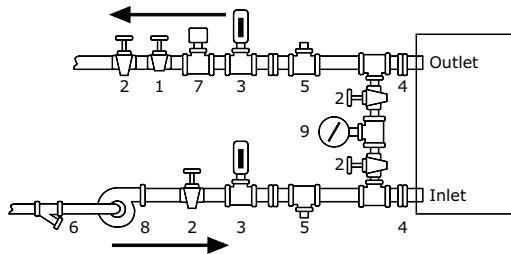

1. Balancing valve.
2. Gate (Isolation) valve or ball valve.
3. Thermometer (if field supplied).
4. Waterbox nozzle connection.
5. Drain, vent, and anode.
6. Strainer.
7. Chilled water flow switch (4B4). Flow switch 4B4 may be installed in either the entering or leaving leg of the chilled water circuit.
8. Pump.
9. Pressure gauge. It is recommended to pipe the gauge between entering and leaving pipes. A shutoff valve on each side of the gauge allows the operator to read either entering or leaving water pressure.

Figure 16. Typical condenser water piping circuits

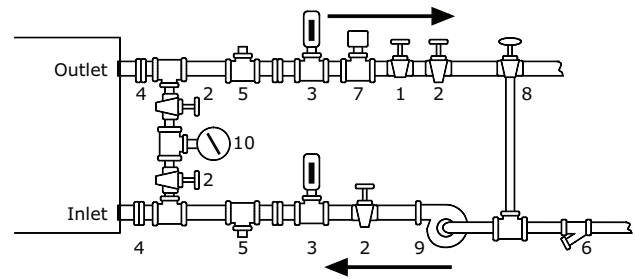

1. Balancing valve.
2. Gate (isolation) valve or ball valve.
3. Thermometer (if field supplied).
4. Waterbox nozzle connection.
5. Drain, vent, and anode.
6. Strainer.
7. Condenser water flow switch (4B5). Flow switch 4B5 may be installed in either the entering or leaving leg of the water circuit.
8. Three-way valve (optional).
9. Condenser water pump.
10. Pressure gauge. It is recommended to pipe a single gauge between entering and leaving pipes.

Notes:

- *Some type of field-supplied temperature control device may be required to regulate the temperature of the heat-recovery condenser water circuit. For application recommendations, refer to Heat Recovery Seminar (Part 2): Systems/Equipment (AM-FND-8).*
- *Install a bypass valve system to avoid circulating water through the auxiliary shell when the unit is shutdown.*
- *On multiple-pass condensers, entering condenser water must enter at the lowest nozzle.*

Piping must be arranged and supported to avoid stress on the equipment. It is strongly recommended that the piping contractor does not run pipe closer than 3 ft (0.9 m) minimum to the equipment. This will allow for proper fit upon arrival of the unit at the job site. Any adjustment that is necessary can be made to the piping at that time. Expenses that result from a failure to follow this recommendation will NOT be paid by Trane.

Water piping connection sizes and components are identified in the tables in “Water Piping Connections,” p. 33 and “Grooved Pipe Coupling,” p. 34. Remember that with many waterboxes, the entering and leaving evaporator water can be piped to either waterbox connection when the tube bundles are split vertically. However, large evaporator waterboxes with entering and leaving connections not at

the same level must be connected with the entering water at the bottom and the leaving water at the top.

Waterboxes with multiple pass arrangements utilize a baffle to separate the passes. These baffles are designed for a maximum pressure of 20 psid (137.9 kPaD). If larger pressure drops are expected in the application, contact your local Trane representative to discuss special waterbox options.

Important: *Water flows must be piped in accordance with nameplate designation.*

Field-provided isolation valves for the evaporator and condenser water lines should be installed upstream and downstream of the heat exchangers, and be installed far enough away from the chiller to also provide practical service isolation for flow sensing devices, field thermometers, flexible connectors, and any removable pipe spools.

Ensure that the evaporator water piping is clear; check it after the chilled water pump is operated but before initial chiller start-up. If any partial blockages exist, they can be detected and removed to prevent possible tube damage resulting from evaporator freeze-up or erosion.

For condenser and large evaporator connections, arrange the water piping so that the water supply enters the shell at the lower connection and exits from the top connection. Operational problems may result if this piping is not correct. Some shells may be piped as desired since both connections are at the same level.

For applications that include an infinite source or multiple-use cooling condenser water supply, install a valved bypass leg (optional) between the supply and return pipes. This valved bypass allows the operator to short-circuit water flow through the cooling condenser when the supply water temperature is too low.

Note: *System refrigerant pressure differential must be maintained above 3 psid (20.7 kPaD) at all times. Failure to do so could result in operating problems.*

Water Piping Connections

All standard units use grooved-pipe connections. These are grooved-end NSP (Victaulic® style) pipe connections. Flanged connections are optional.

Piping joined using grooved type couplings, like all types of piping systems, requires proper support to carry the weight of pipes and equipment. The support methods used must eliminate undue stresses on joints, piping, and other components, allow movement where required, and provide for any other special requirements (i.e., drainage, etc.).

Note: *If needed, plug-type sensor extension cables are available for purchase from Trane Parts Service. These sensor extension cables may be necessary if the waterboxes are changed or if the temperature sensors are moved out into the unit piping for better mixed temperature readings.*

Table 9. Water connection pipe sizes

Water Passes	Shell Size						
	100	130	160	200	220	400	440
Evaporator	Nominal Pipe Size (in.)						
1-Pass	12	12	14	16	20	16	20
2-Pass	10	10	12	14	14	—	—
3-Pass	8	8	10	12	12	—	—
Condenser	Nominal Pipe Size (in.)						
1-Pass	12	14	—	16	24	—	24
2-Pass	10	12	—	14	14	—	—
Evaporator	Metric Pipe Size (mm)						
1-Pass	DN300	DN300	DN350	DN400	DN500	DN400	DN500
2-Pass	DN250	DN250	DN300	DN350	DN350	—	—
3-Pass	DN200	DN200	DN250	DN300	DN300	—	—
Condenser	Metric Pipe Size (mm)						
1-Pass	DN300	DN350	—	DN400	DN600	—	DN600
2-Pass	DN250	DN300	—	DN350	DN350	—	—

Figure 17. Typical grooved pipe connection

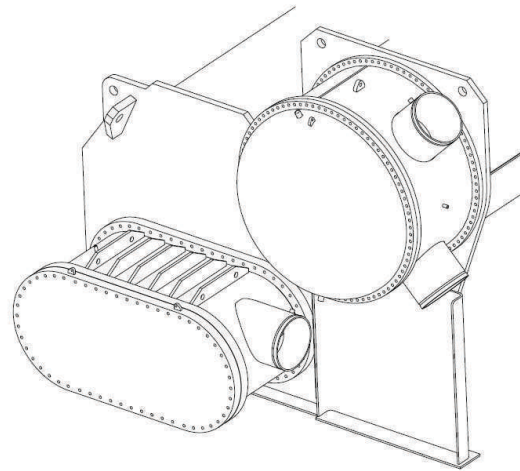

Waterbox Locations

Important: *Do NOT exchange positions of heat recovery waterboxes. Proper unit operation could be affected by repositioning heat recovery waterboxes. Contact CenTraVac™ Chiller Technical Service for more information.*

If necessary, the non-marine-style waterboxes on each shell—whether evaporator or condenser—can be switched end-for-end to obtain the desired piping arrangement.

If removal of waterboxes is necessary, refer to “Waterbox Removal and Installation,” p. 110.

If the waterboxes on any of the shells are exchanged end-for-end, be sure to reinstall them right-side up to maintain

Installation: Water Piping

the correct baffle arrangements. Use a new gasket with each waterbox cover.

Three-pass waterboxes have lifting lugs on the top and bottom. When reinstalling, ensure that the waterbox is oriented the same way it as removed.

Grooved Pipe Coupling

A customer-supplied, standard flexible grooved pipe coupling (Victaulic® Style 77 or equivalent) should be used to complete the Victaulic® connection for both 150 psig (1034.2 kPaG) and 300 psig (2068.4 kPaG) waterboxes.

When a flexible coupling such as this is installed at the waterbox connections, other flexible piping connectors (i.e., braided-steel, elastomeric arch, etc.) are not usually required to attenuate vibration and/or prevent stress on the connections.

Table 10. Water piping connection components

Unit Model	Unit Connection Type	Customer Piping Connection	
		Victaulic®	Flanged
CVHH	Flanged (optional)	Customer provided Victaulic® coupling	No adapter required
CVHH	Victaulic® (all others)	Customer provided Victaulic® coupling	Trane provided Victaulic®-to-flange adapter

Figure 18. Customer piping connection types

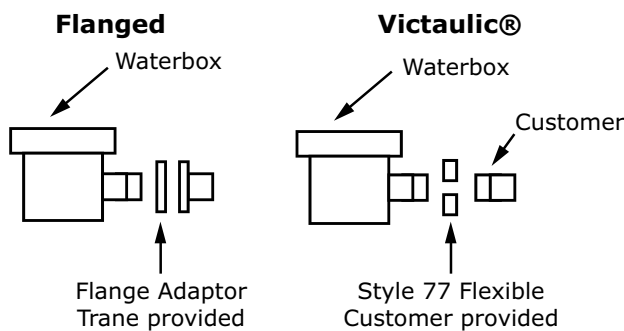

Notes:

- Refer to the coupling manufacturer's guidelines for specific information concerning proper piping system design and construction methods for grooved water piping systems.
- Flexible coupling gaskets require proper lubrication before installation to provide a good seal. Refer to the coupling manufacturer's guidelines for proper lubricant type and application.

Flange-connection Adapters

When flat-face flange connections are specified, flange-to-groove adapters are provided (Victaulic® Style 741 for 150 psig [1034.2 kPaG] systems; Style 743 for 300 psig

[2068.4 kPaG] systems). The adapters are shipped screwed to one of the chiller end-supports. Adapter descriptions are given in the tables in "Victaulic Gasket Installation," p. 35. The flange adapters provide a direct, rigid connection of flanged components to the grooved-pipe chiller waterbox connections.

Figure 19. Typical shipping location for flange

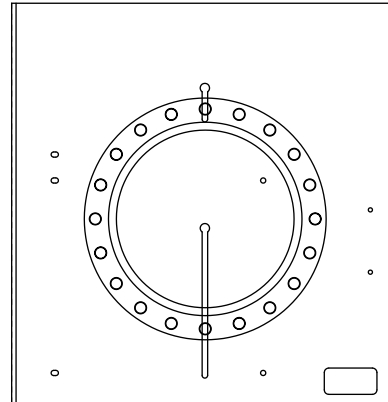

In this case, the use of flexible type connectors (i.e., braided steel, elastomeric arch, etc.) are recommended to attenuate vibration and prevent stress at the waterbox connections. Flange adapters are not provided for CVHH CenTraVac™ chillers with 300 psig (2068.4 kPaG) waterboxes that have 14 in. (355.6 mm) and larger piping connections.

All flange-to-flange assembly screws must be provided by the installer. Hex head screw sizes and number required are included in the tables in "Victaulic Gasket Installation," p. 35. The four draw-bolts needed for the 14 in. (355.6 mm) and larger Style 741 (150 psig [1034.2 kPaG]) adapters are provided. The Style 741 (150 psig [1034.2 kPaG]) flange adapter requires a smooth, hard surface for a good seal.

Connection to other type flange faces (i.e., raised, serrated, rubber, etc.) requires the use of a flange washer between the faces. Refer to the flange adapter manufacturer's guidelines for specific information.

The Style 743 (300 psig [2068.4 kPaG]) flange adapters are designed to mate with raised-face flanges. They can be used with flat-faced flanges, but only if the raised projections on the outside face of the adapter are removed; refer to the following figure. The flange-adapter gasket must be placed with the color-coded lip on the pipe and the other lip facing the mating flange.

NOTICE

Piping Connection Leaks!
Failure to provide effective seal could result in equipment or property-only damage.
To provide effective seal, gasket contact surfaces of adapter must be free of gouges, undulations or deformities.

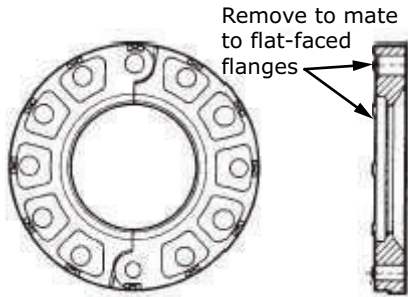
Figure 20. Modifying 300 psig (2068.4 kPaG) or 21 bar flange adapters for flat-faced flange application

4. Open fully and place hinged Victaulic® flange around the grooved pipe end with the circular key section locating into the groove.
5. Insert a standard hex head screw through the mating holes of the Victaulic® flange to secure the flange firmly in the groove.
6. Tighten fasteners alternately and equally until housing screw pads are firmly together (metal-to-metal); refer to “Screw-Tightening Sequence for Water Piping Connections,” p. 36. Do NOT excessively tighten fasteners.

Note: Uneven tightening may cause the gasket to pinch.

Victaulic Gasket Installation

1. Inspect supplied gasket to be certain it is suited for intended service (code identifies gasket grade). Apply a thin coat of silicone lubricant to gasket tips and outside of gasket.
2. Install gasket, placing gasket over pipe end and making sure gasket lip does not overhang pipe end. Refer to the following figure for gasket configuration.
3. Align and bring two pipe ends together and slide gasket into position centered between the grooves on each pipe. No portion of the gasket should extend into the groove on either pipe.

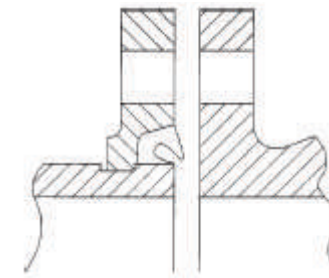
Figure 21. Typical Victaulic® flange gasket configuration
Table 11. Installation data for 150 psig (1034.2 kPaG) flange adapters (Style 741)

Nominal Pipe Size		Assembly Screw Size ^(a)	Number of Assembly Screws Required	Screw Pattern Diameter		Weight	
in.	mm			in.	mm	lb	kg
8	200	3/4 x 3-1/2	8	11.75	298	16.6	7.5
10	250	7/8 x 4	12	14.25	362	24.2	11
12	300	7/8 x 4	12	17	432	46.8	21.2
14	350	1 x 4-1/2	12	18.75	476	62	28.1
16	400	1 x 4-1/2	16	21.25	540	79	35.8
18	450	1-1/8 x 4-3/4	16	22.75	578	82.3	37.3
20	500	1-1/8 x 5-1/4	20	25	635	103.3	46.9
24	600	1-1/4 x 5-3/4	20	29.5	749	142	64.4

^(a) Screw size for conventional flange-to-flange connection. Longer screws are required when flange washer must be used.

Table 12. Installation data for 300 psig (2068.4 kPaG) flange adapters (Style 743)

Nominal Pipe Size		Assembly Screw Size ^(a)	Number of Assembly Screws Required	Screw Pattern Diameter		Weight	
in.	mm			in.	mm	lb	kg
8	219.1	3/4 x 4-3/4	12	13	330	34.3	15.6
10	273.0	1 x 5-1/4	16	15.25	387	48.3	21.9
12	323.9	1-1/8 x 5-3/4	16	17.75	451	70.5	32.0

^(a) Screw size for conventional flange-to-flange connection. Longer screws are required when flange washer must be used.

Screw-Tightening Sequence for Water Piping Connections

This section describes a screw-tightening sequence for flanges with flat gaskets or O-rings. Remember that improperly tightened flanges may leak.

Note: Before tightening any of the screws, align the flanges.

Flanges with 8 or 12 Screws

Tighten all screws to a snug tightness, following the numerical sequence for the appropriate pattern as shown in the following figure. Repeat this sequence to apply the final torque to each screw.

Figure 22. Flange screw tightening sequence (8 or 12 screws)

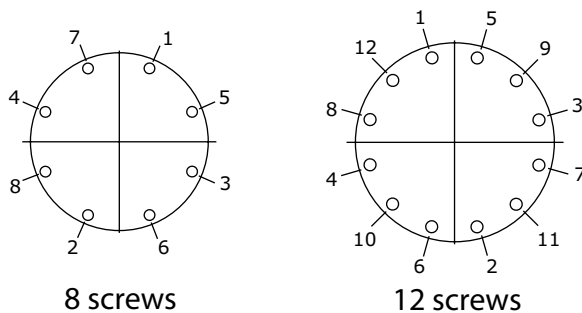

Flanges with 16 or 20 Screws

Tighten only the first half of the total number of screws to a snug tightness, following the numerical sequence for the appropriate pattern as shown in the following figure. Next, sequentially tighten the remaining half of the screws in numerical order.

Figure 23. Flange screw tightening sequence (16 or 20 screws)

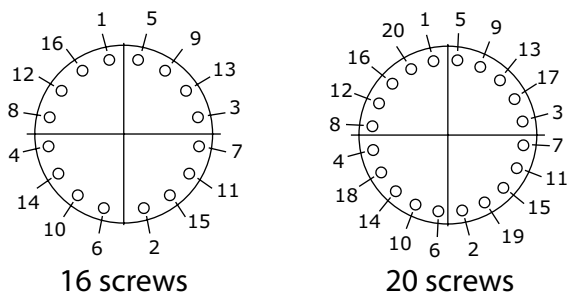

Pressure Testing Waterside Piping

NOTICE

Equipment Damage!

Failure to follow these instructions could result in equipment damage.

Do not over pressurize the system or exceed design pressure. Always perform a hydro pressure test with water present in piping and waterboxes.

Waterside design pressure is either 150 psig (1034.2 kPaG) or 300 psig (2068.4 kPaG); refer to unit nameplate or to submittal documentation.

Eddy Current Testing

Trane recommends conducting an eddy current inspection of the condenser and evaporator tubes in water-cooled chillers every three years. Eddy current tests are intended to identify defects on or within the walls of heat exchanger tubing that could lead to in-service tube failures. Eddy current tests conducted before a chiller is put into service are considered "baseline" eddy current tests, and are intended to establish a reference point to aid in the interpretation of future eddy current test reports. Many of the anomalies that can be found through eddy current testing have no impact on tube life or performance, while others are severe enough to justify removing the affected tube from service. Ask your sales account manager for a copy of the engineering bulletin (CTV-PRB024*-EN) for clarification of the role of eddy current testing in chiller maintenance by providing information about eddy current technology and heat exchanger tubing.



Vent Piping

Refrigerant Vent Line

General Requirements

State and local codes, and ASHRAE Standard 15 contain requirements for venting the relief device on the chiller to the atmosphere outside of the building. These requirements include, but are not limited to, permitted materials, sizing, and proper termination.

Note: *The following information is a general outline of vent-line installation requirements based on ASHRAE Standard 15. Most codes contain similar requirements but may vary in some significant areas. The installer must check state and local codes and follow the specific requirements applicable to the location.*

Purge Discharge

To comply with ASHRAE Standard 15, the discharge piping from purge units that remove non-condensable gas from refrigerating systems must conform to the ASHRAE Standard 15 requirements for relief piping. To help meet this requirement, the purge discharge is factory-piped to the relief device assembly.

Vent Line Materials

All materials in the relief device vent system must be compatible with the refrigerant in use. Commonly used and accepted piping materials include steel and drain/waste/vent (DWV) copper. Consult local codes for restrictions on materials. Consult with the manufacturers of any field-provided components or materials for acceptable material compatibility.

Note: *PVC piping is acceptable for use as a vent-line material with R-1233zd but the glue that joins the sections of plastic pipe may not be. When considering a vent system constructed of plastic piping such as PVC, ensure that both the pipe material and the adhesive have been tested for refrigerant compatibility. In addition, verify that the local codes permit PVC for refrigerant vent lines; even though ASHRAE Standard 15 doesn't prohibit its use, some local codes do.*

The following materials for PVC pipe construction are recommended for use with R-1233zd:

Primer/Cleaner:

- Hercules – PVC Primer #60-465
- RECTORSEAL® PVC Cleaner – Sam™ CL-3L

Adhesives:

- Hercules – Clear PVC, Medium Body/Medium Set, #60-020
- RECTORSEAL® – PVC Cement, Gene™ 404L

Vent Line Sizing

Vent line size must conform to local codes and requirements. In most cases, local codes are based on ASHRAE Standard 15. ASHRAE Standard 15 provides specific requirements for the discharge piping that allows pressure-relief devices to safely vent refrigerant to the atmosphere if over-pressurization occurs. In part, the standard mandates that:

- The minimum pipe size of the vent line must equal the size of the discharge connection on the pressure-relief device. A larger vent line size may be necessary, depending on the length of the run.
- Two or more relief devices can be piped together *only if* the vent line is sized to handle all devices that could relieve at the same time.
- When two or more relief devices share a common vent line, the shared line must equal or exceed the sum of the outlet areas of all upstream relief devices, depending on the resulting back pressure.

ASHRAE Standard 15 provides guidance for determining the maximum vent line length. It also provides the equation and data necessary to properly size the vent line at the outlet of a pressure-relief device or fusible plug (for more information, refer to “[Vent Line Sizing Reference](#),” p. 41).

The equation accounts for the relationship between pipe diameter, equivalent pipe length, and the pressure difference between the vent line inlet and outlet to help ensure that the vent line system provides sufficient flow capacity.

The tables in “[Vent Line Sizing Reference](#),” p. 41 provide additional information based on ASHRAE Standard 15, including:

- Capacities of various vent line sizes and lengths. However, this data applies only to conventional pressure-relief valves and NOT to balanced relief valves, rupture members (as used on Trane® centrifugal chillers), fusible plugs, or pilot-operated valves.
- A simplified method to determine the appropriate vent-line size, using the figures (in I-P or SI units) in “[Vent Line Sizing Reference](#),” p. 41. Enter the figure with the total **C** value, read across to a pipe curve and down to find the maximum allowable length for that size pipe.

Note: *To determine the total C value for a specific unit, add the appropriate C values for the evaporator, standard condenser, and economizer. If the unit is equipped with any options (e.g., heat recovery, free cooling, or an auxiliary condenser), add the applicable C value(s) for those options to the total as well.*



Vent Piping

Note: The tables and figures in “Vent Line Sizing Reference,” p. 41 are applicable only for non-manifolded vent-line runs connected to a 50 psig (344.7 kPaG) rupture disk relief device. The pipe length provided by the table is in “equivalent feet.” The vent-line length in equivalent feet is the sum of the linear pipe length plus the equivalent length of the fittings (e.g., elbows).

Vent Line Installation

Important: Before constructing the rupture disk vent line, consult local codes for applicable guidelines and constraints.

All CenTraVac™ centrifugal chillers are equipped with rupture disks. If refrigerant pressure within the evaporator exceeds 50 psig (344.7 kPaG), the rupture disk breaks and shell pressure is relieved as refrigerant escapes from the chiller.

A cross-section of the rupture disk assembly appears in the following figure (rupture disk location and cross section), along with an illustration indicating the location of the rupture disk on the suction elbow.

Several general recommendations for rupture disk vent line installation are outlined as follows.

Note: If the rupture disk was removed for service or vent-line piping installation, the rupture disk must be reinstalled (as shown in the following figure [rupture disk location and cross section]). Refer to the following procedure and contact CenTraVac™ Chiller Technical Service when reinstalling the rupture disk.

- Verify that the rupture disk is positioned as shown in the cross-section view that appears in the following figure (rupture disk location and cross section).
 - Install the two bottom hex head screws through the pipe flanges.
 - Install the rupture disk with a gasket on each side between the pipe flanges. Orient the disk with the reference arrow facing the chiller side as shown in the following figure (rupture disk location and cross section).
 - Install the two top hex head screws.
 - Center the disk and gaskets to the flange bore.
 - Hand-tighten all screws, assuring equal pressure.
 - Use a torque wrench set to 145 ft·lb (196.6 N·m) with a 24-mm socket.
 - Tighten screws in a star pattern, one half turn each, to maintain even pressure on the disk.
 - Final torque on all screws should be 145 ft·lb (196.6 N·m).
- When attaching the vent line to the chiller, do NOT apply threading torque to the outside pipe of the rupture disk assembly.

NOTICE

Rupture Disk Damage!

Failure to follow instruction could result in damage to the rupture disk assembly.

Do not apply threading torque to the outside pipe.

- Provide support as needed for the vent line. Do NOT use the rupture disk assembly to support the vent-line piping.
- Use a flexible connection between the vent line and the rupture disk assembly to avoid placing stress on the rupture disk. (Stress can alter rupture pressure and cause the disk to break prematurely.) The flexible connector used to isolate the rupture disk from excessive vent line vibration must be compatible with the refrigerant in use. Use a flexible, steel connector (such as the stainless-steel type MFP, style HNE, flexible pump connector from Vibration Mounting and Control, Inc.), or equivalent. Refer to the following figure (arrangement for rupture disk relief piping) for a recommended relief piping arrangement.

⚠ WARNING

Pressure-Relief Device Discharge Hazard!

An improper vent-line termination could result in death or serious injury or equipment damage.

When a pressure-relief device operates, it could discharge a large amount of fluid and/or vapor. Units MUST be equipped with a vent-line termination that discharges outdoors in an area that will not spray refrigerant on anyone.

NOTICE

Proper Refrigerant Vent Line Termination!

Failure to properly terminate a refrigerant vent line could result in equipment damage.

Improperly terminating a refrigerant vent line could allow rain to enter the line. Accumulated rainwater could cause the relief device to malfunction; or, in the case of a rupture disk, the rainwater pressure could cause the disk to rupture, allowing water to enter the chiller.



Note: Graphic labels (shown above) are used for CE application only.

- Route the vent-line piping so that it discharges outdoors in an area that will not spray refrigerant on anyone. Position the vent-line discharge at least 15 ft (4.6 m) above grade level and at least 20 ft (6.1 m) from any building opening. Provide a vent-line termination that cannot be blocked by debris or accumulate rainwater.
- Provide a drip leg on the vent line (refer to the following figure [arrangement for rupture disk relief piping]). Provide a standard 1/4-in. FL x 1/4-in. NPT, capped refrigerant service valve to facilitate liquid removal.

NOTICE

Equipment Damage!

Failure to follow instructions below could result in equipment damage.

All vent lines must be equipped with a drip leg of sufficient volume to hold the expected accumulation of water and/or refrigerant. The drip leg must be drained periodically to assure that it does not overflow and allow fluid to flow into the horizontal portion of the vent line. Trane assumes no responsibility for equipment damage caused by insufficient drainage of drip leg.

- Consult local regulations and codes for any additional relief line requirements.

Figure 24. Rupture disk location and cross section of rupture disk

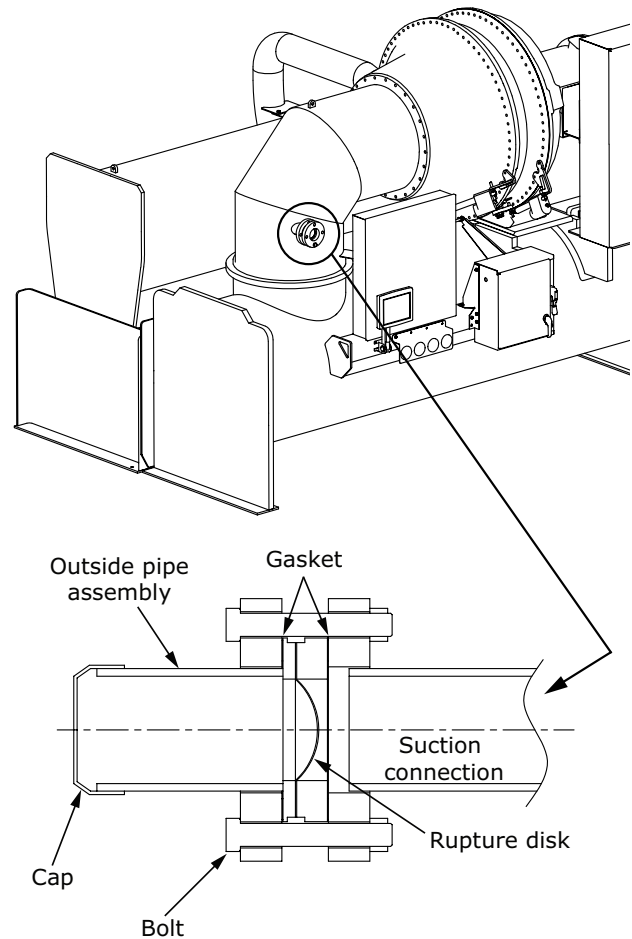

Note: Pipe connection is 3 in. (76.2 mm) NPT.

Figure 25. Arrangement for rupture disk relief piping

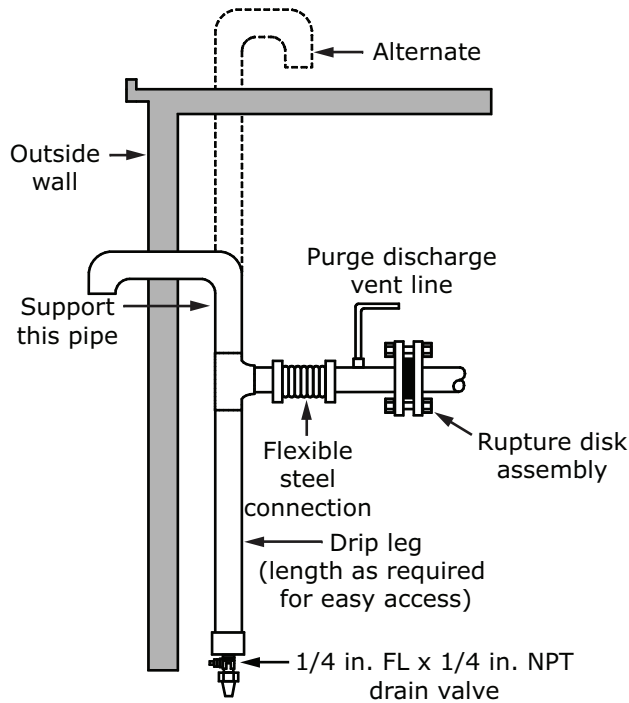

Important: On the purge discharge vent line, the purge exhaust connection point **MUST** be lower than the purge height. Do **NOT** create a U-trap; extend to drip leg if necessary to avoid a trap.

Note: The drip leg is **REQUIRED**. The drip leg should be a minimum of 1 gal (3.8 L) capacity and must be drained periodically for proper chiller purge operation.

Trane RuptureGuard

General Information

The Trane RuptureGuard™ refrigerant containment system replaces the carbon rupture disk on new low pressure chillers utilizing R-1233zd. The RuptureGuard™ consists of a solid-metal, (non-fragmenting) reverse-buckling rupture disk and automatically re-seating relief valve. The relief valve and the rupture disk are rated at the chiller's maximum working pressure level. If the chiller's refrigerant pressure exceeds the rupture disk burst rating, the disk bursts, releasing pressure to the relief valve. The relief valve vents the pressure down to a safe level and then re-seats, thus minimizing the amount of refrigerant vented to the atmosphere. The following figure illustrates the operation of a reverse buckling rupture disk.

Figure 26. Reverse buckling rupture disk (top view)

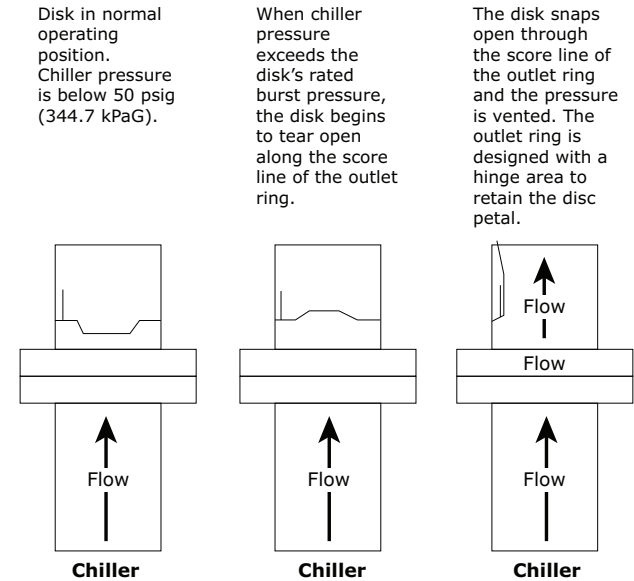

To prevent water, refrigerant, and/or other debris such as rust from hindering the operation of the valve, a drip leg should be installed immediately after or downstream of the RuptureGuard™ (refer to the figure in "Connection to External Vent Line and Drip Leg," p. 40).

Connection to External Vent Line and Drip Leg

NOTICE

Equipment Damage!
 Failure to follow instructions below could result in equipment damage.
All vent lines must be equipped with a drip leg of sufficient volume to hold the expected accumulation of water and/or refrigerant. The drip leg must be drained periodically to assure that it does not overflow and allow fluid to flow into the horizontal portion of the vent line. Trane assumes no responsibility for equipment damage caused by insufficient drainage of drip leg.

With RuptureGuard™ installed horizontally, the drain plug downstream of the valve relief plug and nearest to the bottom of the valve body should be piped to the drip leg in the vent line (refer to the following figure). This will allow the removal of any condensate formed within the valve body.

Provisions, such as installing a set of flanges (refer to the following figure) or other disconnect means, must be made in the discharge vent piping. This will allow the piping downstream of the valve to be easily removed for an annual inspection, to replace the metal RuptureGuard™ disk, or for any other servicing need.

1. Connect the discharge of the valve assembly to the vent line connected to the outdoors.

Note: Make sure there are no crosses (a derate on the rated flow capacity for this configuration is published in Engineering Bulletin: RuptureGuard Selection Guide [E/CTV-EB-10]), elbows, tees, or any other obstructions within the first 9 in. (22.86 cm) of valve discharge. Refer to ASHRAE Standard 15, national, state, and local codes for additional requirements on piping rupture disk and relief valve vent lines.

Figure 27. External vent line and drip leg (not provided)

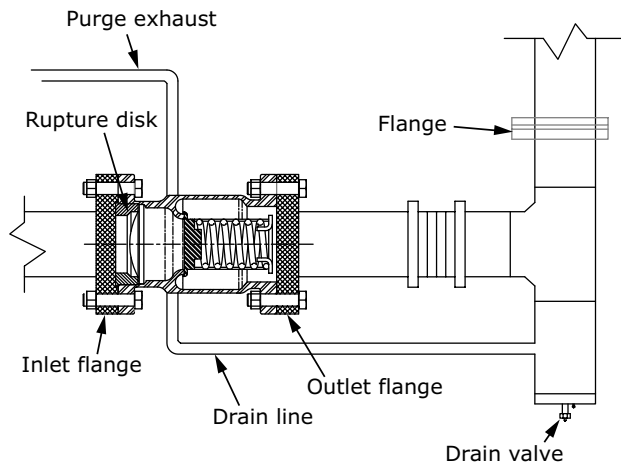

Note: The drip leg is **REQUIRED**. The drip leg should be a minimum of 1 gal (3.8 L) capacity and must be drained periodically for proper chiller purge operation.

Important: If a RuptureGuard™ is to be installed, it **MUST** be installed properly. Failure to properly install the RuptureGuard™ will likely result in a start-up delays and required rework and expenses that result from a failure to properly install the RuptureGuard™ will **NOT** be paid by Trane.

Vent Line Sizing Reference

Table 13. “C” values used to determine rupture disk vent line sizes (lb/min); for use with the following figure

NTON	Evap. Size (EVSZ)	Cond. Size (CDSZ)	“C” Values for Unit Components				
			Total “C” Value	Evap.	Cond.	Econ.	Oil Tank
900–1200	100M	100M	112.0	48.4	40.7	18.5	4.5
900–1200	100L	100L	123.2	54.5	45.8	18.5	4.5
900–1200	130M	130M	122.4	54.0	45.4	18.5	4.5
900–1200	160M	200M	134.1	60.5	50.7	18.5	4.5
900–1200	200L	220L	160.4	75.4	62.1	18.5	4.5
900–1200	220L	220L	168.6	83.6	62.1	18.5	4.5
1500–1700	200L	200L	156.8	75.4	57.1	19.8	4.5
1500–1700	220L	220L	169.9	83.6	62.1	19.8	4.5
900–1200	100M	10HM	127.0	48.4	55.7	18.5	4.5
900–1200	130M	13HM	138.2	54.0	61.3	18.5	4.5
900–1200	160M	20HM	150.2	60.5	66.8	18.5	4.5
1500–1700	200L	20HL	174.9	75.4	75.2	19.8	4.5
1500–1700	220L	22HL	191.4	83.6	83.6	19.8	4.5

Notes:

1. Rupture disk diameter is 3 in.
2. Use the total “C” value in the following figure to determine the vent line pipe diameter.
3. If piping multiple rupture disks (multiple units) to a common vent line, first determine the total “C” value for each unit, and then; add all “C” values together and apply the result to the following figure.
4. The CVHH unit is a Simplex chiller and has (1) refrigerant circuit and (1) relief device.



Vent Piping

Figure 28. Rupture disk vent pipe sizing (IP units); for use with preceding table

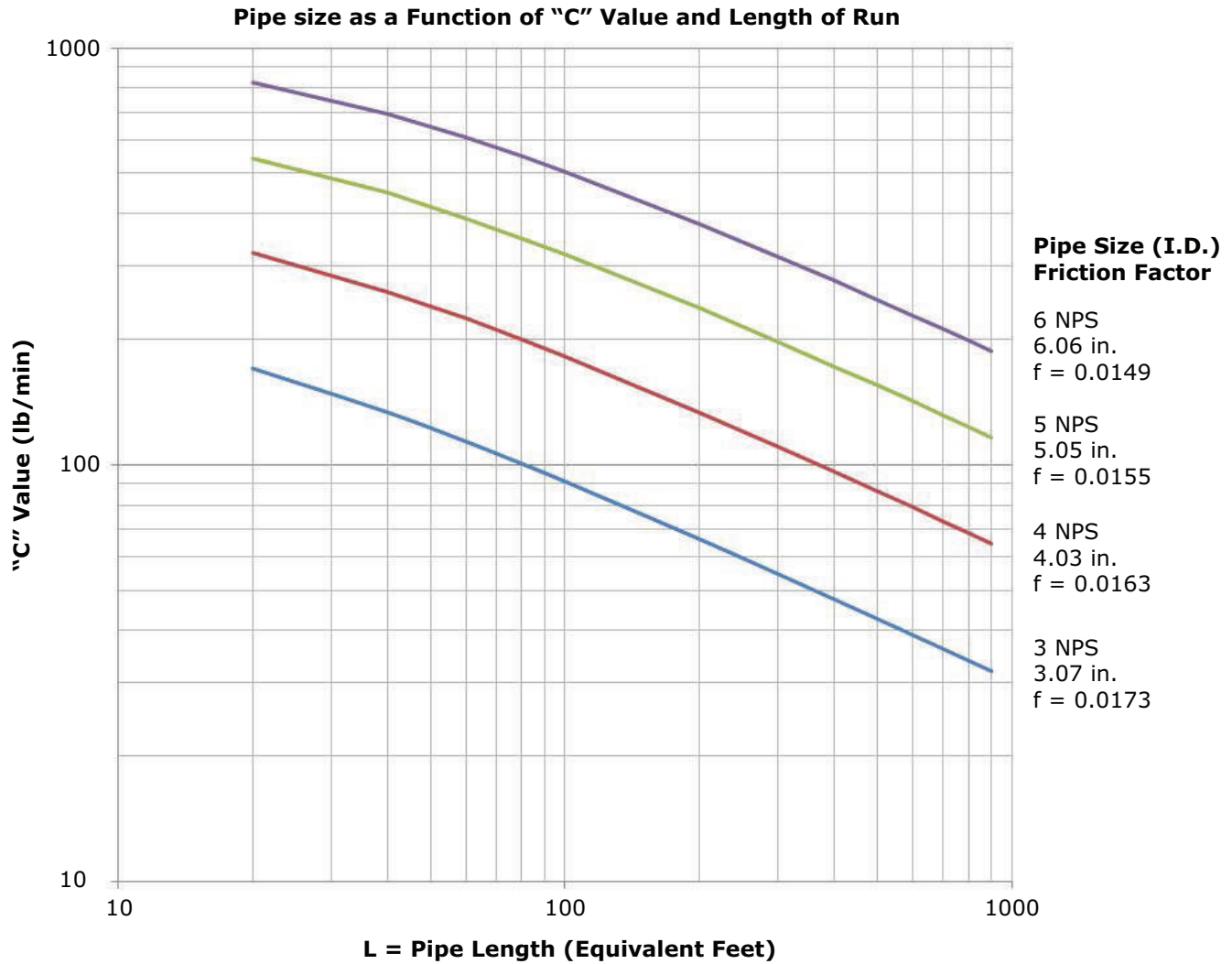

Note: The preceding figure, provided as a reference, is based on ASHRAE Standard 15. Vent line size is typically dictated by state or local code which may be different from ASHRAE Standard 15 requirements.

ASHRAE Standard 15

$$L = \frac{0.214d^5 (P_0^2 - P_2^2)}{fC_R^2} - \frac{d * \ln(P_0 / P_2)}{6f}$$

- L = equivalent length of discharge piping, feet
- C_R = rated capacity as stamped on the relief device in SCFM (conversion: lb/min = SCFM * 0.0764)
 $C_R = C$ value in lb/min from the preceding table
- f = Moody friction factor in fully turbulent flow
- d = inside diameter of pipe or tube, in.
- \ln = natural logarithm
- P_2 = absolute pressure at outlet of discharge piping, psi (atmospheric pressure)
- P_0 = allowed back pressure (absolute) at the outlet of pressure relief device, psi
 - If chiller uses a rupture guard:
 $P_0 = (0.15 P) + \text{atmospheric pressure}$
 - If chiller uses a rupture disk:
 $P_0 = (0.5 P) + \text{atmospheric pressure}$

Table 14. “C” values used to determine rupture disk vent line sizes (kg/s); for use with the following figure

NTON	Evap. Size (EVSZ)	Cond. Size (CDSZ)	“C” Values for Unit Components				
			Total “C” Value	Evap.	Cond.	Econ.	Oil Tank
900–1200	100M	100M	0.853	0.368	0.310	0.141	0.034
900–1200	100L	100L	0.939	0.415	0.349	0.141	0.034
900–1200	130M	130M	0.932	0.412	0.346	0.141	0.034
900–1200	160M	200M	1.022	0.461	0.386	0.141	0.034
900–1200	200L	220L	1.222	0.575	0.473	0.141	0.034
900–1200	220L	220L	1.284	0.637	0.473	0.141	0.034
1500–1700	200L	200L	1.195	0.575	0.435	0.151	0.034
1500–1700	220L	220L	1.295	0.637	0.473	0.151	0.034
900–1200	100M	10HM	0.967	0.368	0.424	0.141	0.034
900–1200	130M	13HM	1.053	0.412	0.467	0.141	0.034
900–1200	160M	20HM	1.144	0.461	0.509	0.141	0.034
1500–1700	200L	20HL	1.332	0.575	0.573	0.151	0.034
1500–1700	220L	22HL	1.458	0.637	0.637	0.151	0.034

Notes:

1. Rupture disk diameter is 76.2 mm.
2. Use the total “C” value in the following figure to determine the vent line pipe diameter.
3. If piping multiple rupture disks (multiple units) to a common vent line, first determine the total “C” value for each unit, and then; add all “C” values together and apply the result to the following figure .
4. The CVHH unit is a Simplex chiller and has (1) refrigerant circuit and (1) relief device.



Vent Piping

Figure 29. Rupture disk vent pipe sizing (SI units); for use with preceding table

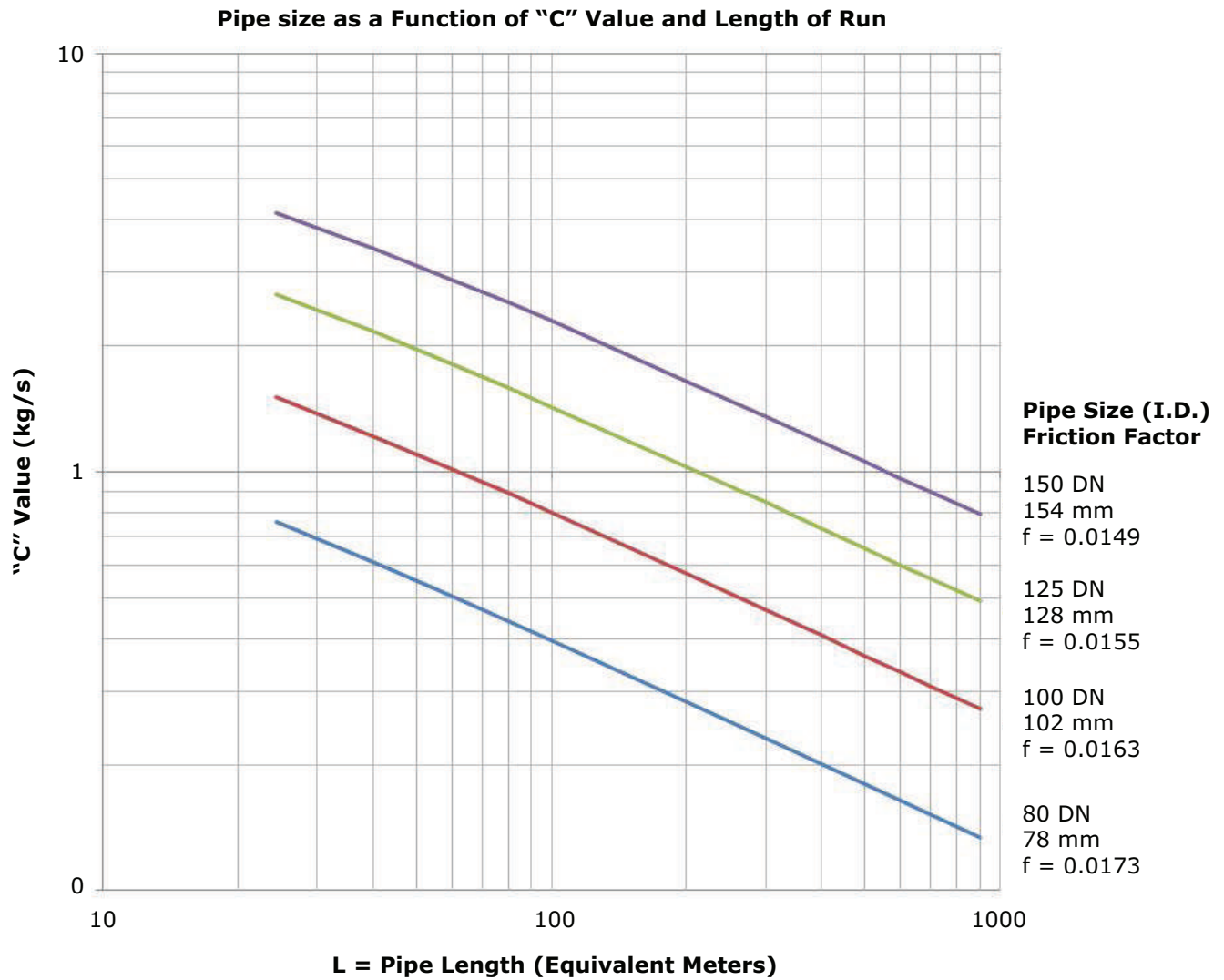

Note: The preceding figure, provided as a reference, is based on ASHRAE Standard 15. Vent line size is typically dictated by state or local code which may be different from ASHRAE Standard 15 requirements.

ASHRAE Standard 15

$$L = \frac{7.4381 \times 10^{-15} d^5 (P_0^2 - P_2^2)}{f C_R^2} - \frac{d * \ln(P_0 / P_2)}{500f}$$

- L = equivalent length of discharge piping, meters
- C_R = rated capacity as stamped on the relief device in SCFM (conversion: kg/s = SCFM * 0.0764 / 132.28)
 - $C_R = C$ value from the preceding table (convert C in kg/s to lb/min for IP; lb/min = (kg/s) / 132.28)
- f = Moody friction factor in fully turbulent flow
- d = inside diameter of pipe or tube, mm
- \ln = natural logarithm
- P_2 = absolute pressure at outlet of discharge piping, kPa (atmospheric pressure)
- P_0 = allowed back pressure (absolute) at the outlet of pressure relief device, kPa
 - If chiller uses a rupture guard:
 $P_0 = (0.15 P) + \text{atmospheric pressure}$
 - If chiller uses a rupture disk:
 $P_0 = (0.5 P) + \text{atmospheric pressure}$



Insulation

Unit Insulation Requirements

Factory-installed insulation is available as an option for all units. Factory installation does NOT include insulation of the chiller feet; if required, insulation for chiller feet is provided by others. In applications where the chiller is not factory-insulated, install insulation over the areas outlined and highlighted with dashed lines as shown in the figure in "Factory-applied Insulation," p. 46.

Insulate all 1/4-in. (6.35-mm) eductor lines, one from the suction cover and one from the evaporator, to prevent sweating.

The quantities of insulation required based on unit size and insulation thickness are listed in the following table. Insulation thickness is determined at normal design conditions which are:

- Standard comfort-cooling leaving chilled water temperature
- 85°F (29.4°C) dry bulb ambient temperature
- 75 percent relative humidity

Operation outside of normal design conditions as defined in this section may require additional insulation; contact Trane for further review.

Note: *If the unit is not factory-insulated, install insulation around the evaporator bulbwells and ensure that the bulbwells and connections for the waterbox drains and vents are still accessible after insulation is applied. The sensor modules (Low Level Intelligent Devices [LLIDs]) and interconnecting four-wire cable inter-processor communication (IPC) bus must be raised up above the field-installed insulation. Secure the IPC bus to the insulation top/outer surface after insulation is completed.*

Important: Do NOT insulate the motor housing, unit wiring, or sensor modules.

⚠ WARNING

Replace Manual in Cabinet After Use!

Failure to replace this Installation, Operation, and Maintenance manual in cabinet after use could prevent personnel from accessing necessary safety information and could result in death or serious injury or equipment damage.

NOTICE

Equipment Damage!

Failure to remove the strain relief with the sensor could result in equipment damage.
Do NOT attempt to pull sensor bulb through the strain relief; always remove the entire strain relief with the sensor.

Table 15. Evaporator insulation requirements

EVSZ (Standard Unit)	3/4 in. (19.05 mm) Insulation	
	Square Feet	Square Meters
100M	661	61.4
100L	680	63.2
130M	684	63.5
160M	711	66.1
200M	738	68.6
200L	765	71.1
220M	770	71.5
220L	799	74.2

Notes:

1. Units are NOT insulated on the motor or refrigerant drain lines.
2. 3/4-in. (19.05-mm) sheet insulation is installed on the evaporator, evaporator waterboxes, suction elbow, suction cover, economizer, liquid lines, and piping.
3. Copper oil eductor lines require pipe insulation.

Insulation Thickness Requirements

Factory-applied Insulation

All low-temperature surfaces are covered with 3/4 in. (19.05 mm) Armaflex® II or equal (thermal conductivity = 0.25 Btu/h-ft² [0.036 W/m² - K]), evaporator, waterboxes, suction elbow, economizer, and piping.

The insulation is Armaflex® or equivalent closed cell elastomeric insulation to prevent the formation of condensation in environments with a relative humidity up to 75 percent. Chillers in high humidity areas or ice storage, low leaving water temperature (less than 36°F [2.2°C] chilled water temperature/glycol) units, may require double thickness to prevent formation of condensation.

NOTICE

Insulation Damage!

Failure to follow these instructions could result in insulation damage.

To prevent damage to factory installed insulation:

- Do not allow the insulation to be exposed to excessive sunlight. Store indoors or cover with canvas to prevent exposure.
- Do not use thinners and solvents or other types of paint. Use only water base latex.

Figure 30. Recommended area for unit insulation

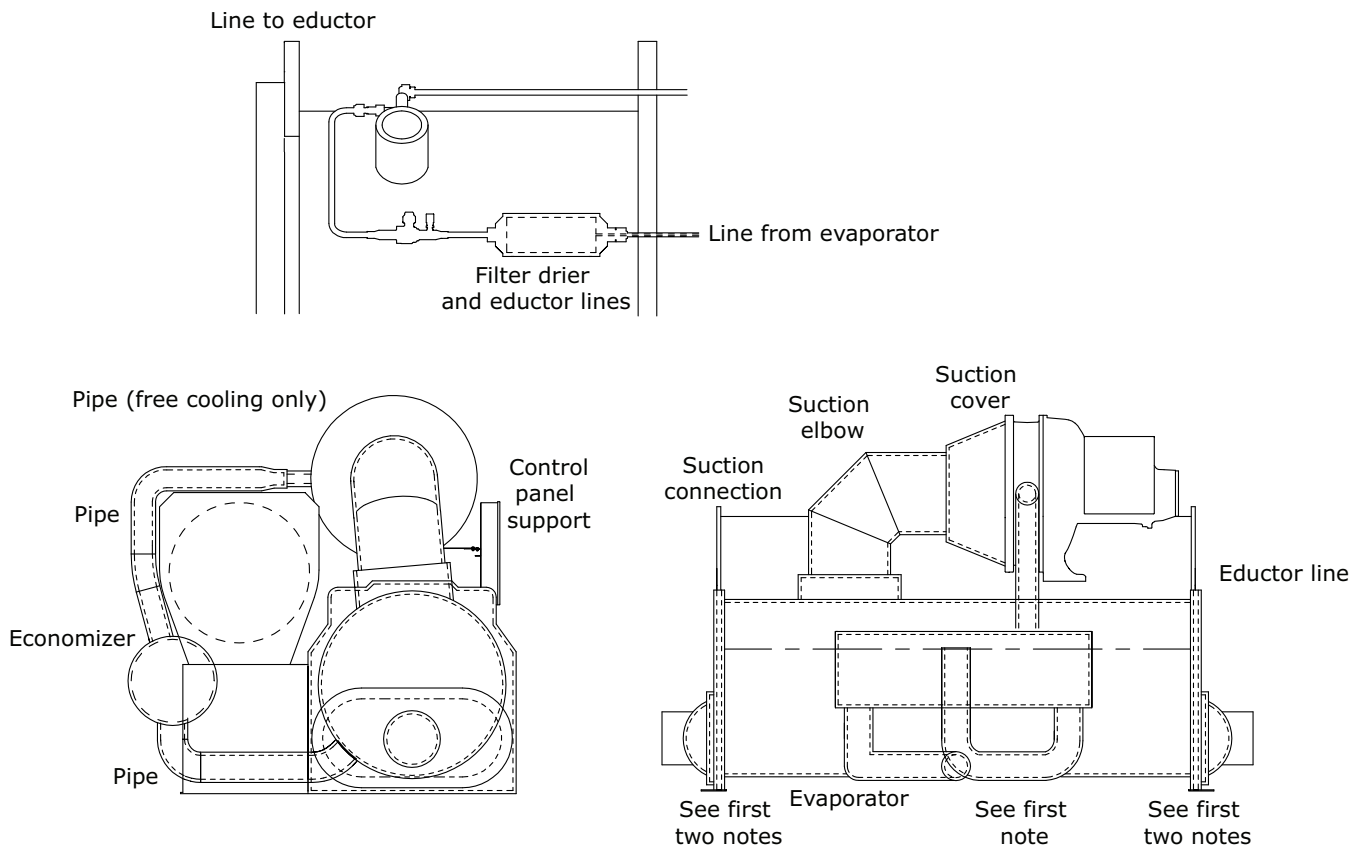

Notes:

- *Bulbwells, drain, and vent connections must be accessible after insulating.*
- *All units with evaporator marine waterboxes: wrap waterbox shell insulation with strapping and secure strapping with seal.*
- *Evaporators with pressure vessel nameplates must have insulation cut out around the nameplate. Do NOT glue insulation to the nameplate.*
- *Apply 2-in. (50.8-mm) wide black tape on overlap joints. Where possible, apply 3-in. (7.6-cm) wide strip of 0.38-in. (9.7-mm) thick insulation over butt joint seams.*
- *Insulate all economizer supports.*



Installation: Controls

This section covers information pertaining to the Symbio™ 800 controller hardware. For information about the Tracer® AdaptiView™ display, which is used to interface with the internal chiller data and functions provided by the Symbio™ 800, refer to *Tracer® AdaptiView™ Display for Water-cooled CenTraVac™ Chillers with Symbio™ Controls User Guide* (CTV-SVU004*-EN).

Symbio™ 800

The Symbio 800 controller is a factory-installed, application specific and programmable controller designed to control chillers and large packaged HVAC equipment. A 12 inch user interface features a touch-sensitive color screen that provides facility managers at-a-glance operating status, performance monitoring, scheduling changes, and operating adjustments. Other advanced features include automated controller back-up, and optional features such as secure remote connectivity, wireless building communications, mobile device connectivity, and custom programming with an expandable I/O.

For more information, see *Symbio™ 800 Controller Installation, Operation, and Maintenance* (BAS-SVX080*-EN).

AdaptiView™ Display

Information is tailored to operators, service technicians, and owners. When operating a chiller, specific information is needed on a day-to-day basis—setpoints, limits, diagnostic information, and reports. This information is provided through the AdaptiView display. Logically organized groups of information — chiller modes of operation, active diagnostics, settings and reports put information conveniently at your fingertips.

For more information, see *CenTraVac™ Water-Cooled Chillers AdaptiView™ Display with Symbio™ Controls User Guide* (CTV-SVU004*-EN).

Tracer TU

The AdaptiView TD12 operator interface allows for daily operational tasks and setpoint changes. However, to adequately service chillers, Tracer® TU service tool is required. (Non-Trane personnel, contact your local Trane office for software purchase information.) Tracer TU adds a level of sophistication that improves service technician effectiveness and minimizes chiller downtime. This portable PC-based service-tool software supports service and maintenance tasks, and is required for software upgrades, configuration changes and major service tasks.

Tracer TU serves as a common interface to all Trane chillers, and will customize itself based on the properties of the chiller with which it is communicating. Thus, the service technician learns only one service interface.

The panel bus is easy to troubleshoot using LED sensor verification. Only the defective device is replaced. Tracer TU can communicate with individual devices or groups of devices.

All chiller status, machine configuration settings, customizable limits, and up to 100 active or historic diagnostics are displayed through the service-tool software interface.

LEDs and their respective Tracer TU indicators visually confirm the availability of each connected sensor, relay, and actuator.

Tracer TU is designed to run on a customer’s laptop, connected to the Tracer® Symbio™ 800 control panel with a USB cable. Your laptop must meet the following hardware and software requirements:

- 4 GB RAM
- 1024 x 768 screen resolution
- Ethernet 10/100 LAN card
- An available USB 2.0 port
- Windows 7 Enterprise or Professional operating system (32-bit or 64-bit)

Note: *Tracer TU versions 8.6 and earlier will also support Microsoft® Windows® XP Professional operation system with Service Pack 3 (SP3) .*

- Microsoft .NET Framework 4.8 or later

Notes:

- *Tracer TU is designed and validated for this minimum laptop configuration. Any variation from this configuration may have different results. Therefore, support for Tracer TU is limited to only those laptops with the configuration previously specified.*
- *For more information, see Tracer® TU Service Tool Getting Started Guide (TTU-SVN01*-EN).*

Figure 31. Tracer TU

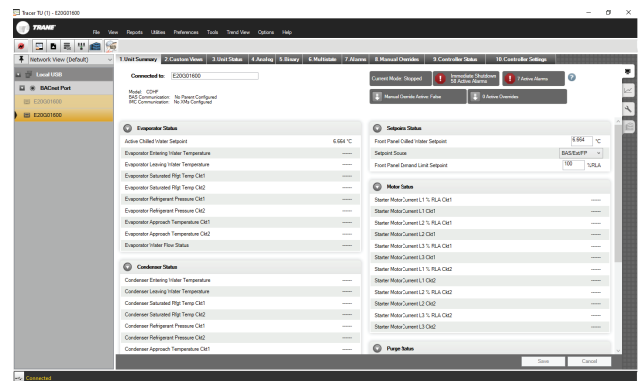

Control Panel

Figure 32. Control panel: main unit assembly
(showing low voltage and higher voltage areas for proper routing of field wiring)

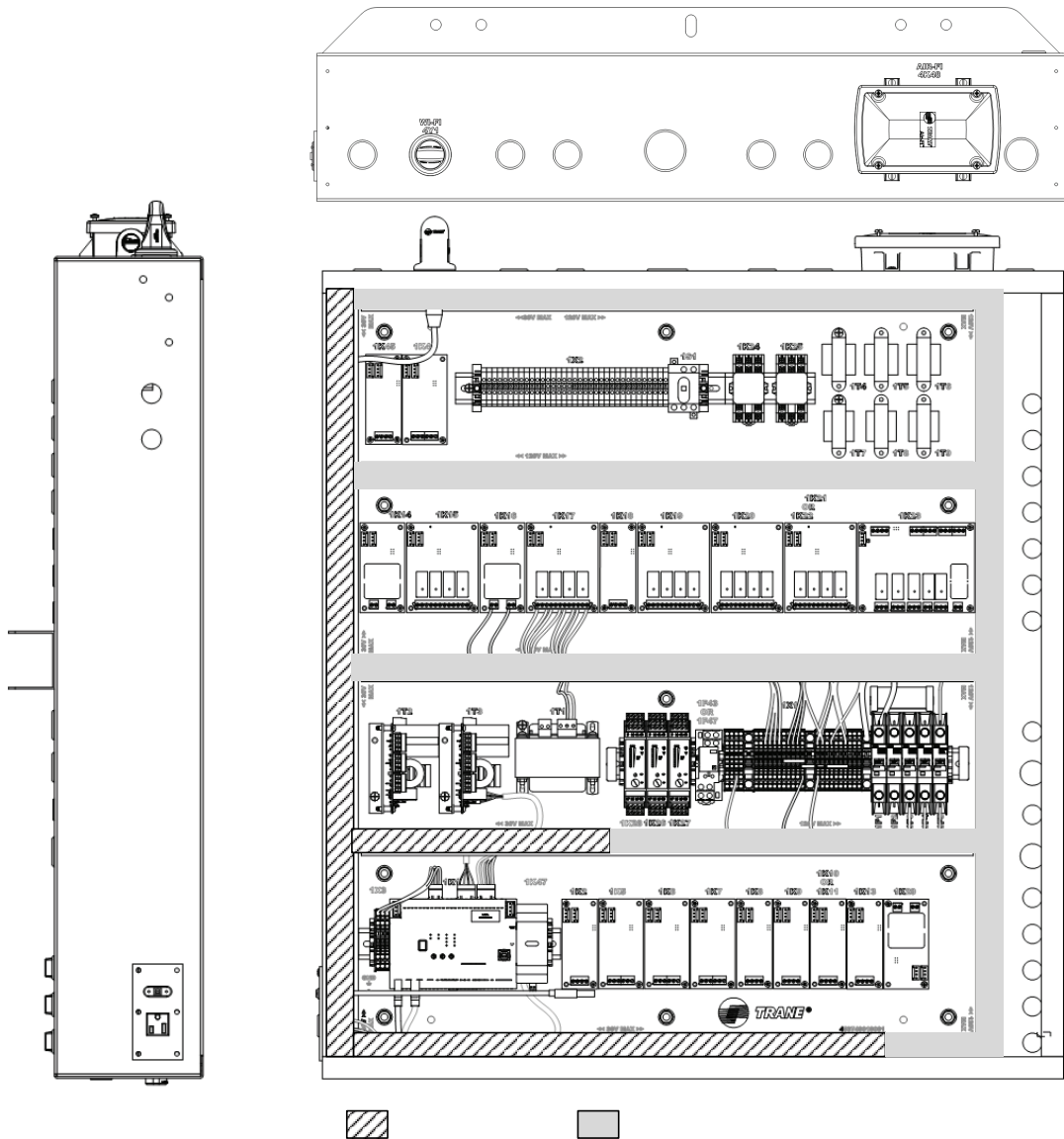

Installing the Tracer® AdaptiView™ Display

During shipment, the Tracer® AdaptiView™ display is boxed, shrink-wrapped, and located behind the control panel. The display must be installed at the site.

Important: For best results, Trane, or an agent of Trane, must install the Tracer® AdaptiView™ display and support arm.

1. Unwrap the control panel and display arm. Locate the box containing the Tracer® AdaptiView™ display behind the control panel (labeled A in the following figure).
2. After the box containing the display has been removed, remove the shipping bracket from the back of the control panel (labeled B in the following figure).
3. Remove the display from the box.

Note: Display screws are M4 (metric size 4), 6 to 8 mm long, and are shipped with the display.

4. Symbio™ 800 will only work with AdaptiView™ part number X13760359001 or greater. Check to ensure the correct part number prior to installation.

Note: The previous AdaptiView™ display (X13760326050) will only work with UC800 controllers.

5. Plug the power cable (labeled C in the following figure) and the Ethernet cable (labeled D in the following figure) into the bottom of the display.

Note: Both cables are already present and extend from the end of the display arm.

6. Adjust the Tracer® AdaptiView™ display support arm so the base plate that attaches to the display is horizontal.

⚠ CAUTION

Tension in Display Support Arm!

Failure to follow instructions below could result in unexpected movement of the spring-loaded support arm which could result in minor to moderate injury.

Ensure that the support arm is in the full upright position when removing the Tracer AdaptiView display from the support arm.

Note: Review “Adjusting the Tracer® AdaptiView™ Display Arm,” p. 51 before attaching the display as some adjustments may be required prior to attaching the display to the support arm base.

7. Position the Tracer® AdaptiView™ display with the LCD screen facing up on top of the display support arm base plate.

Note: Ensure the Trane logo is positioned so that it will be at the top when the display is attached to the display support arm.

Important: Use care when positioning the Tracer® AdaptiView™ display on top of the support arm base plate and do NOT drop the display.

8. Align the four holes in the display with the screw holes in the display support arm base plate.
9. Attach the Tracer® AdaptiView™ display to the display support arm base plate (labeled E in the following figure) using the M4 (metric size 4) screws referenced in step 3.

Figure 33. Tracer® AdaptiView™ shipping location

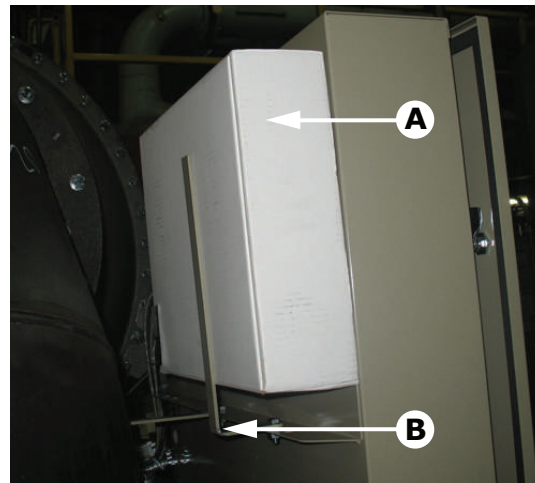

Figure 34. Power cable and Ethernet cable connections

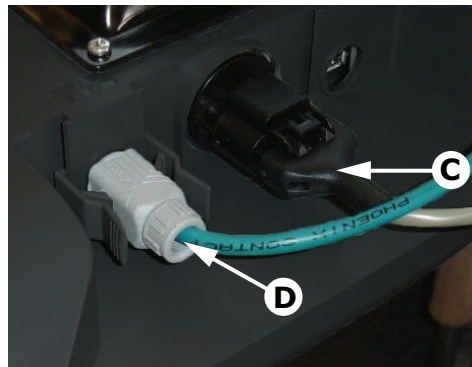
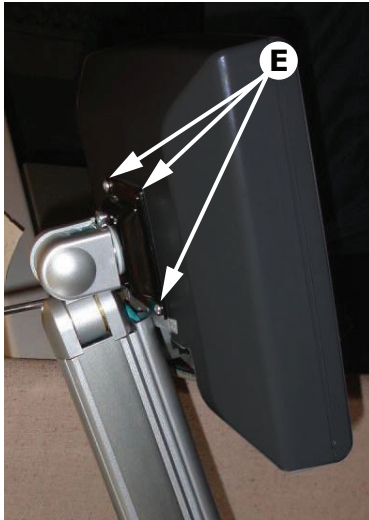

Figure 35. Display attachments to the support arm base plate



Adjusting the Tracer[®] AdaptiView[™] Display Arm

The Tracer[®] AdaptiView[™] display arm may become too loose or too tight and may need adjustment. There are three joints on the display arm that allow the display to be positioned at a variety of heights and angles (refer to items labeled 1, 2, and 3 in the following figure).

Figure 36. Joint locations on the display arm

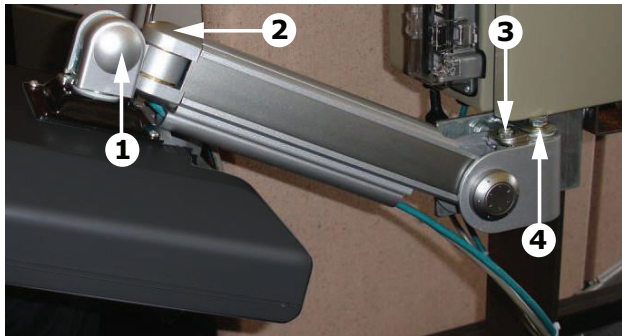

To adjust the tension on the display arm:

- At each joint in the display arm, there is either a hex bolt (1 and 2) or hex screw (3). Turn the hex bolt or screw in the proper direction to increase or decrease tension.

Note: Each hex bolt or screw is labeled with *loosen/tighten* or +/- indicators.
- Joint 3 has a 6 mm hex screw controlling the tension on a gas spring, which allows the Tracer[®] AdaptiView[™] display to tilt up and down.
- Joints 1 and 2 are covered by a plastic cap. Remove the plastic cap to access the screw. Adjust using a 13 mm wrench as necessary.
- To adjust the swivel rotation tension of the Tracer[®] AdaptiView[™] display, adjust the screw located in the support arm base plate, as described in the final step in the Installing the Tracer[®] AdaptiView[™] Display section.. *This adjustment must be done prior to attaching the display to the support arm base.* Use a 14 mm wrench to adjust the tension.
- To adjust the left/right swivel of the entire display arm, use a 13 mm wrench to adjust the screw labeled 4 in the preceding figure.

Module Installation

Air-Fi®

For installation instructions, see *Air-Fi® Wireless Communications Interface (WCI) Installation Instructions* (BAS-SVN038*-EN).

Recommended routing from Air-Fi® module to Symbio™ 800 using factory provided mounting provision is shown in figure below. Device can be remote mounted in order to obtain a stronger signal.

Figure 37. Air-Fi® wire harness routing path

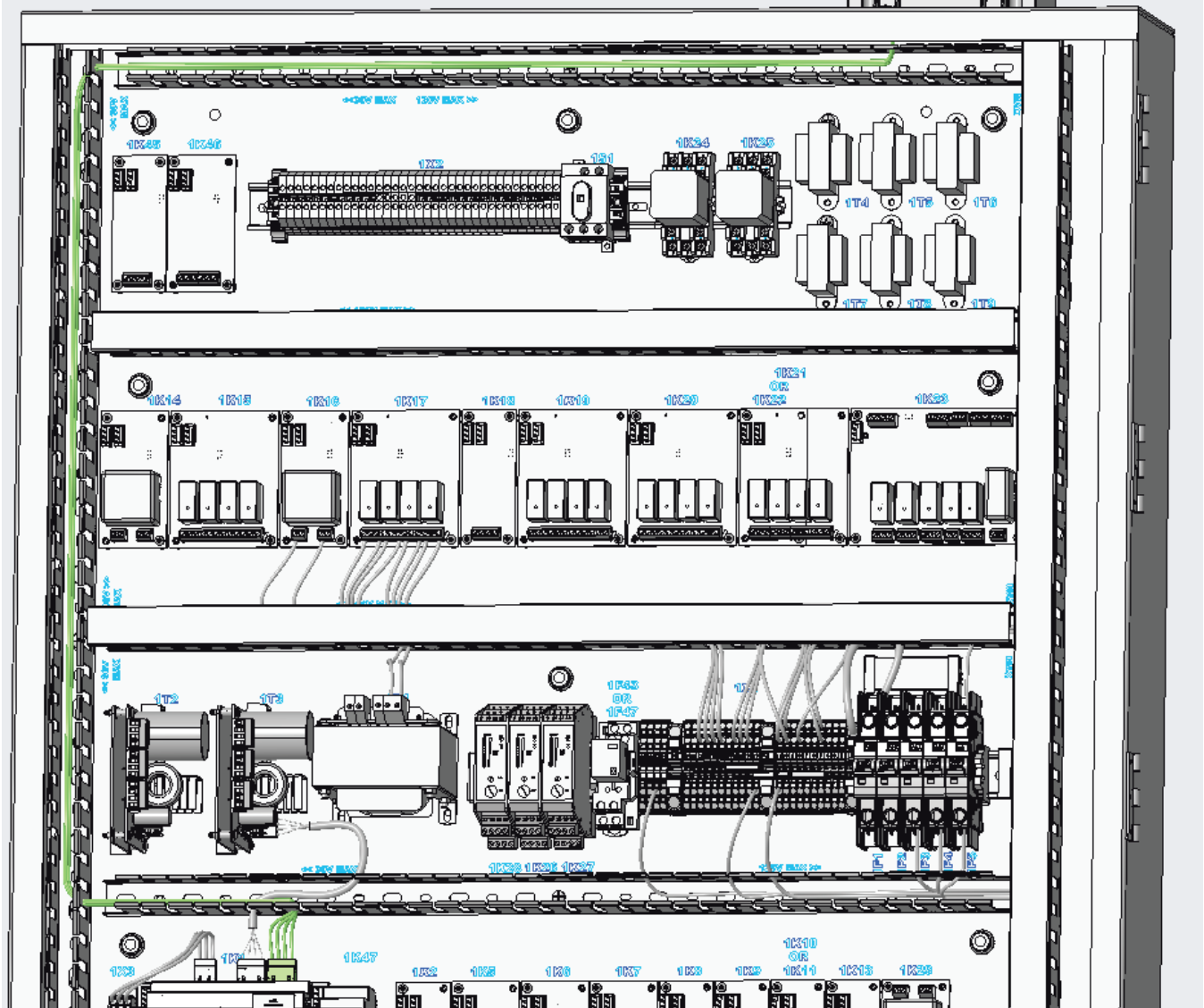

Wi-Fi

For installation instructions, see *Trane® Wi-Fi Module Installation Instructions* (BAS-SVN042*-EN).

Recommended routing from Wi-Fi module to Symbio™ 800 using factory provided mounting provision is shown in figure below. Device can be remote mounted in order to obtain a stronger signal.

Figure 38. Wi-Fi wire harness routing path

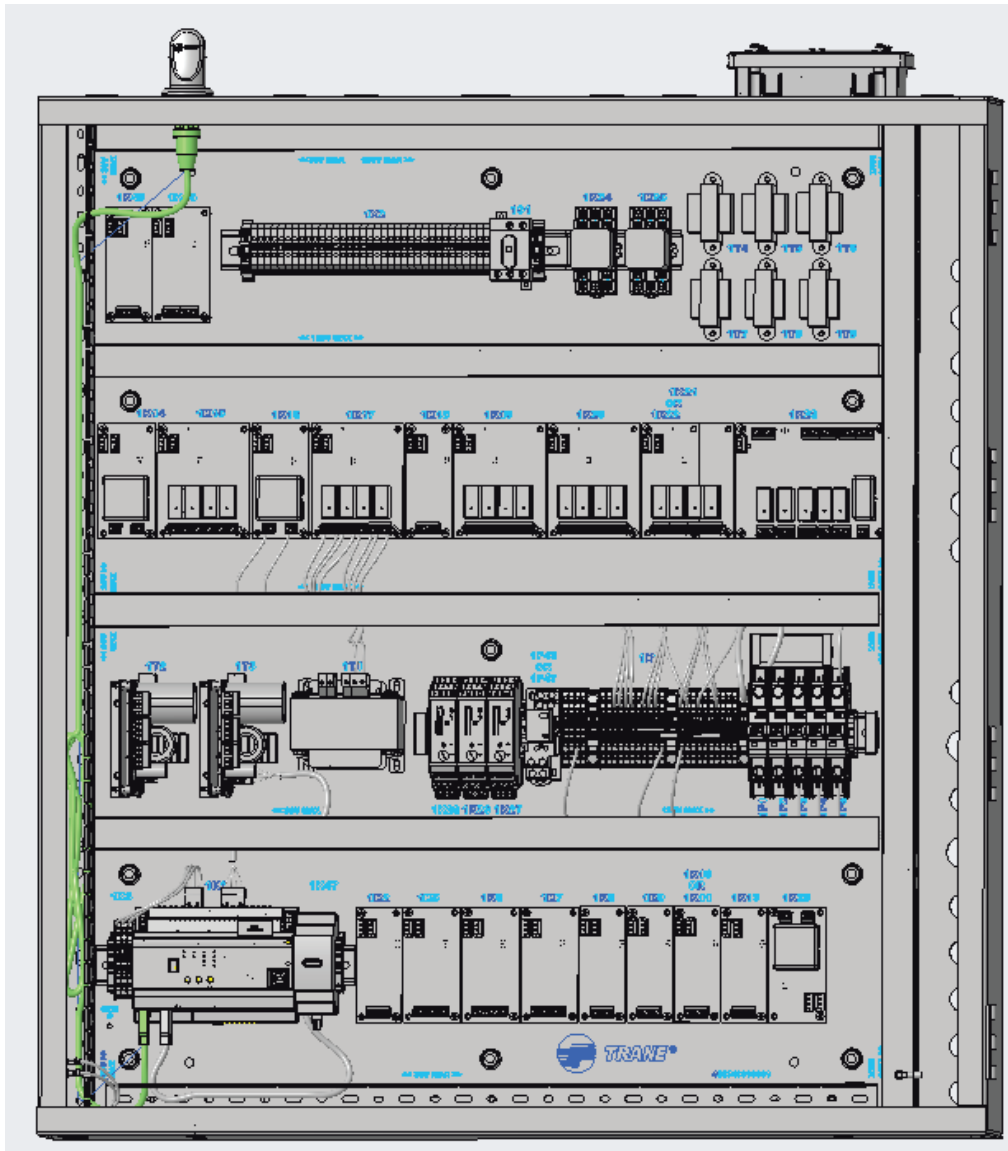

Electrical Requirements

Installation Requirements

⚠ WARNING

Proper Field Wiring and Grounding Required!

Failure to follow code could result in death or serious injury.

All field wiring **MUST** be performed by qualified personnel. Improperly installed and grounded field wiring poses **FIRE** and **ELECTROCUTION** hazards. To avoid these hazards, you **MUST** follow requirements for field wiring installation and grounding as described in NEC and your local/state/national electrical codes.



Note: Graphic labels (shown above) are used for CE application only.

Important:

- Before servicing, disconnect all power sources and allow at least 30 minutes for capacitors to discharge.
- All electrical enclosures—unit or remote—are IP2X.

Unit-mounted starters are available as an option on most units. While this option eliminates most field-installed wiring requirements, the electrical contractor must still complete the electrical connection for the following:

- Power supply wiring to the starter
- Other unit control options present
- Any field-supplied control devices

As you review this manual along with the wiring instructions presented in this section, keep in mind that:

- All field-installed wiring must conform to National Electric Code (NEC) guidelines, and any applicable

local, state, and national codes. For the USA, be sure to satisfy proper equipment grounding requirements per NEC.

- Compressor motor and unit electrical data (including motor kW, voltage utilization range, rated load amps, and locked rotor amps) is listed on the chiller nameplate.
- All field-installed wiring must be checked for proper terminations, and for possible shorts or grounds.

Note: Always refer to the actual wiring diagrams that shipped with the chiller or the unit submittal for specific as-built electrical schematic and connection information.

NOTICE

Adaptive Frequency Drive (AFD)/Starter Component Damage!

Failure to remove debris from inside the AFD/starter panel could result in an electrical short and could cause serious AFD/starter component damage.

Do NOT modify or cut enclosure to provide electrical access. Removable panels have been provided, and any modification should be done away from the enclosure. If the starter enclosure must be cut to provide electrical access, exercise care to prevent debris from falling inside the enclosure. Refer to installation information shipped with the starter or submittal drawings.

Electrical Requirements

Before wiring begins, observe the following electrical requirements:

- Follow all lockout/tagout procedures prior to performing installation and/or service on the unit.
- Always wear appropriate personal protective equipment.
- Wait the required time to allow the capacitor(s) to discharge; this could be up to 30 minutes.
- Verify that all capacitors are discharged prior to service using a properly rated volt meter.
- Use appropriate capacitor discharge tool when necessary.
- Comply with the safety practices recommended in PROD-SVB06*-EN.

For AWG/MCM equivalents in mm², refer to the following table.

Table 16. Wire sizing reference

AWG/MCM	mm ² Equivalent
22	0.32
21	0.35

Table 16. Wire sizing reference (continued)

AWG/MCM	mm ² Equivalent
20	0.5
18	0.75
17	1.0
16	1.5
14	2.5
12	4
10	6
8	10
6	16
4	25
2 or 1	35
1/0	50
2/0	70
2/0 or 3/0	95
4/0 or 250	120
300	150
350 or 400	185
450 or 500	240

Note: AWG = American Wire Gauge.

Important: Customers are responsible for all field wiring in compliance with international, national, and/or local codes.

⚠ WARNING

Hazardous Voltage w/Capacitors!

Failure to disconnect power and discharge capacitors before servicing could result in death or serious injury.

Disconnect all electric power, including remote disconnects and discharge all motor start/run capacitors before servicing. Follow proper lockout/tagout procedures to ensure the power cannot be inadvertently energized. For variable frequency drives or other energy storing components provided by Trane or others, refer to the appropriate manufacturer's literature for allowable waiting periods for discharge of capacitors. Verify with a CAT III or IV voltmeter rated per NFPA 70E that all capacitors have discharged.

⚠ WARNING

Personal Protective Equipment (PPE) Required!

Failure to wear PPE and follow proper handling guidelines could result in death or serious injury. Always wear appropriate personal protective equipment in accordance with applicable regulations and/or standards to guard against potential electrical shock and flash hazards.

⚠ WARNING

Live Electrical Components!

Failure to follow all electrical safety precautions when exposed to live electrical components could result in death or serious injury.

When it is necessary to work with live electrical components, have a qualified licensed electrician or other individual who has been properly trained in handling live electrical components perform these tasks.



Note: Graphic labels (shown above) are used for CE application only.

Important:

- Before servicing, disconnect all power sources and allow at least 30 minutes for capacitors to discharge.
- All electrical enclosures—unit or remote—are IP2X.

Trane-supplied Remote Starter Wiring

This information is applicable to Starter 1 for Compressor 1 as well as Starter 2 for Compressor 2. (For wire estimation purposes, double check the following table as there are two starters to be wired.)

Important: The information in the table below is applicable to Standard Starters or Drive Options. Consult As-Built, Submittal and/or consult Tech Support for Sales orders with design special drives and starters.



Electrical Requirements

Table 17. Standard field power wiring requirements

Power Supply Wiring to Starter Panel	Starter Panel Terminals			
3-Phase Line Voltage	L1, L2, L3, and Ground ^(a)			
Starter to Motor Power Wiring	Starter	Motor		
Remote Starter to Chiller Motor Junction Box	T1 through T6	T1 through T6		
Power Supply Wiring to Unit-Mounted Control Power Transformer (CPTR Optional)	Control Power Transformer Terminals			
3-Phase Line Voltage ^(b)	6Q1-1,3,5			
Ground	CPTR Panel GND			
Starter to Control Panel 120 Vac Control Wiring	Starter Panel Terminals	Unit Control Panel Terminations		
120 Vac Power Supply (from Starter to Control Panel without optional CPTR)	2X8-2 2X8-G (Ground)	1X1-1, 1X1-12 1X1-30 (Ground)		
120Vac Power Supply (from Starter to Control Panel with optional CPTR)	2X8-1, 2X8-2, 2X8-G (Ground)	1X1-1, 1X1-12, 1X1-31(Ground)		
High Pressure Cutout to Starter	2X8-4	1X1-4		
1F1 Circuit Breaker to Starter	2X8-3	1X1-2		
Oil Pump Interlock	2X8-7, 2X8-8	1X1-10, 1X1-21		
Low-voltage Starter Oil/Refrigerant Pump Start	2X8-24	1X1-21		
Medium-voltage Starter Oil/Refrigerant Pump Start	2X8-14	1X1-21		
Low-voltage Oil/Refrigerant Pump Neutral	2X8-25	1X1-16		
Medium-voltage Oil/Refrigerant Pump Neutral	2X8-15	1X1-16		
Starter to Oil/Refrigerant Pump Junction Box	Starter Panel Terminals	Oil/Refrigerant Pump Junction Box		
Low Voltage 3-Phase Pump Power	2X8-21, 2X8-22, 2X8-23	4X4-1, 4X4-2, 4X4-3		
Medium Voltage 1-Phase Pump Power	2X8-12, 2X8-13	4X4-1, 4X4-4		
Low Voltage Circuits Less Than 30 Vac	Starter Panel Terminals	Unit Control Panel Terminations		
Standard Circuits				
Inter-processor Communications (IPC) Remote-Mounted ^(c) ^(d)	2K32-J3-3-4, or 2X8-19 to 21 if Present (Do NOT Ground Shield at Starter)	1T2-J5-3-4 Shield Ground at 1X1-34 (GND) Only	2-wire with Gound Comm Link	

Notes:

1. All wiring to be in accordance with National Electrical Code (NEC) and any local codes.
 2. For AWG/MCM equivalents in mm², refer to the table in "Electrical Requirements," p. 54.
 3. Auxiliary equipment must be powered from other sources as the chiller control panel power supplies are sized for the chiller loads only.
- (a) Ground lug for a unit-mounted solid state starter or wye-delta starter is sized to accept 14 AWG solid to 8 AWG strand wire. If local codes require different lug size, it must be field-supplied and -installed.
- (b) Refer to submittal and ship-with wiring schematics for voltage requirements.
- (c) Must be separated from 120 Vac and higher wiring.
- (d) The maximum distance a Trane-supplied remote starter can be placed from the chiller is 1000 ft (305 m).



Customer-supplied Remote Starter Wiring

Important: The information in the table below is applicable to Standard Starter or Drive Options. Consult As-Builts, Submittal and/or consult Tech

Support for Sales orders with design special drives and starters.

Table 18. Standard customer-supplied remote field wiring requirements

Power Supply Wiring to Starter Panel	Starter Panel Terminals		
Starter by Others 3-phase Power Wiring	See Starter by Others Schematic		
Starter to Motor Power Wiring	Starters	Motor	
Remote Starter to Chiller Motor Junction box ^(a)	T1 through T6 Terminals	T1 through T6 Terminals	
Power Supply Wiring to Unit-Mounted Control Power Transformer (CPTR)	Control Power Transformer Terminals		
3-Phase line voltage ^(b)	6Q1-1,3,5		
Ground	CPTR Panel GND		
Starter to Control Panel 120 Vac Control Wiring	Starter Panel Terminals	Unit Control Panel Terminations	
Power from Control Panel 1F1	5X12-3	1X1-2	
Neutral from Control Panel	5X12-2	1X1-13	
Ground from Control Panel	5X12-G	1X1-31	
Interlock Relay Signal	5X12-4	1K23 J10-1	
Start Contactor Signal	5X12-5	1K23 J8-1	
Oil Pump Interlock	5X12-7, 5X12-8	1X1-10, 1X1-21	
Run Contactor Signal	5X12-10	1K23 J6-1	
Transition Complete	5X12-14	1K23 J12-2	
Solid State Starter Fault ^(c)	5X12-12 5X12-11	1K13 J2-2 1K13 J2-1	
Low Voltage Circuits less than 30 Vac	Starter Panel Terminals	Unit Control Panel Terminations	
Standard Circuits			
Current Transformers (refer to table in "Current Transformer and Potential Transformer Wire Sizing," p. 58) (Required) ^(d)	5X12-19	1K23 J7-1	Note: Phasing Must be Maintained
	5X12-20	1K23 J7-2	
	5X12-21	1K23 J7-3	
	5X12-22	1K23 J7-4	
	5X12-23	1K23 J7-5	
Potential Transformers (Required)	5X12-24	1K23 J7-6	
	5X12-25	1K23 J5-1	
	5X12-26	1K23 J5-2	
	5X12-27	1K23 J5-3	
	5X12-28	1K23 J5-4	
	5X12-29	1K23 J5-5	
	5X12-30	1K23 J5-6	

Notes:

1. All wiring to be in accordance with National Electrical Code (NC) and any local codes.
2. For AWG/MCM equivalents in mm², refer to the table in "Electrical Requirements," p. 54.
3. Starter by Others Specification available from your local Trane sales office.

^(a) Wires, lugs, and fuses/breakers are sized based on National Electric Code (NEC) [NFPA 70] and UL 1995.

^(b) Refer to submittal and ship-with wiring schematics for voltage requirements.

^(c) Solid State Starter Fault input is used with low- and medium-voltage, customer-supplied solid state starters only.

^(d) Must be separated from 120 Vac and higher wiring.



Customer-supplied Remote Starter Wiring

Current Transformer and Potential Transformer Wire Sizing

For customer-supplied starter-to-chiller unit control panel starter module 1K23; these wires must be separated from 120 Vac or higher wiring.

Table 19. Maximum recommended wire length for secondary current transformer (CT) leads in dual CT system

Wire AWG ^(a)	Maximum Wire Length Secondary CT Leads	
	Feet	Meters
8	1362.8	415.5
10	856.9	261.2
12	538.9	164.3
14	338.9	103.3
16	213.1	65.0
17	169.1	51.5
18	134.1	40.9
20	84.3	25.7

Notes:

1. For AWG/MCM equivalents in mm², refer to the table in "Electrical Requirements," p. 54.
2. Wire length is for copper conductors only.
3. Wire length is total one-way distance that the CT can be from the starter module.

^(a) Wires, lugs, and fuses/breakers are sized based on National Electric Code (NEC) [NFPA 70] and UL 1995.

Table 20. Maximum recommended total wire length for potential transformers (PTs) in a single PT system

Wire AWG ^(a)	Maximum Lead Length	
	Feet	Meters
8	5339	1627
10	3357	1023
12	2112	643
14	1328	404
16	835	254
17	662	201
18	525	160
20	330	100
21	262	79
22	207	63

Notes:

1. For AWG/MCM equivalents in mm², refer to the table in "Electrical Requirements," p. 54.
2. Wire length is for copper conductors only.
3. Wire length is maximum round trip wire length. The maximum distance the PT can be located from the starter module is half of the listed value.

^(a) Wires, lugs, and fuses/breakers are sized based on National Electric Code (NEC) [NFPA 70] and UL 1995.

Table 21. Maximum recommended total wire length (to and from) for PT leads in a dual PT system

Wire AWG ^(a)	Max Wire Length Primary		Max Wire Length Secondary	
	Feet	Meters	Feet	Meters
8	3061	933	711	217
10	1924	586	447	136
12	1211	369	281	85
14	761	232	177	53
16	478	145	111	33
17	379	115	88	26
18	301	91	70	21
20	189	57	44	13
21	150	45	34	10
22	119	36	27	8

Notes:

1. For AWG/MCM equivalents in mm², refer to the table in "Electrical Requirements," p. 54.
2. Wire length is for copper conductors only.
3. Wire length is maximum round trip wire length. The maximum distance the PT can be located from the starter module is half of the listed value.

^(a) Wires, lugs, and fuses/breakers are sized based on National Electric Code (NEC) [NFPA 70] and UL 1995.

Power Supply Wiring

⚠ WARNING

Proper Field Wiring and Grounding Required!

Failure to follow code could result in death or serious injury.

All field wiring **MUST** be performed by qualified personnel. Improperly installed and grounded field wiring poses **FIRE** and **ELECTROCUTION** hazards. To avoid these hazards, you **MUST** follow requirements for field wiring installation and grounding as described in NEC and your local/state/national electrical codes.



Note: Graphic labels (shown above) are used for CE application only.

Important:

- Before servicing, disconnect all power sources and allow at least 30 minutes for capacitors to discharge.
- All electrical enclosures—unit or remote—are IP2X.

Three-Phase Power

Review and follow the guidelines in this section to properly install and connect the power supply wiring to the starter panel:

- Verify that the starter nameplate ratings are compatible with the power supply characteristics and with the electrical data on the unit nameplate.

NOTICE

Adaptive Frequency Drive (AFD)/Starter Component Damage!

Failure to remove debris from inside the AFD/starter panel could result in an electrical short and could cause serious AFD/starter component damage.

NOTICE

Use Copper Conductors Only!

Failure to use copper conductors could result in equipment damage as the equipment was not designed or qualified to accept other types of conductors.

- Do NOT modify or cut enclosure to provide electrical access. Removable panels have been provided and any modification should be done away from the enclosure. If the starter enclosure must be cut to provide electrical access, exercise care to prevent debris from falling inside the enclosure.
- Use copper conductors to connect the three-phase power supply to the remote- or unit-mounted starter panel.
- Flexible conduit connections are recommended to enhance serviceability and minimize vibration transmission.
- Size the power supply wiring in accordance with National Electric Code (NEC) and local guidelines, using the RLA value stamped on the chiller nameplate and transformer load on L1 and L2.
- Confirm that wire size is compatible with lug size stated in unit submittal.
- Make sure that the incoming power wiring is properly phased; each power supply conduit run to the starter must carry the correct number of conductors to ensure equal phase representation.

Note: Connect L1, L2, and L3 (shown in the following figure) per starter diagram provided with chiller.

- When installing the power supply conduit, ensure that the position of the conduit does not interfere with the serviceability of any of the unit components, or with structural members and equipment. Ensure that the conduit is long enough to simplify any servicing that may be necessary in the future (e.g., starter).
- Electrical wire torque specifications — follow starter manufacturers torque specifications.

Figure 39. Proper phasing for starter power supply wiring

Unit-mounted Starters

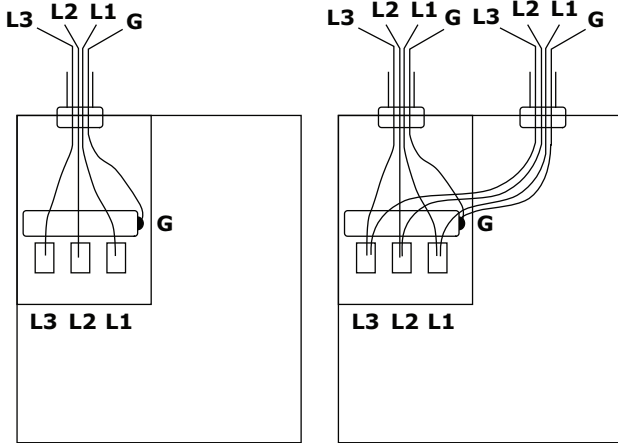

Remote-mounted Starters

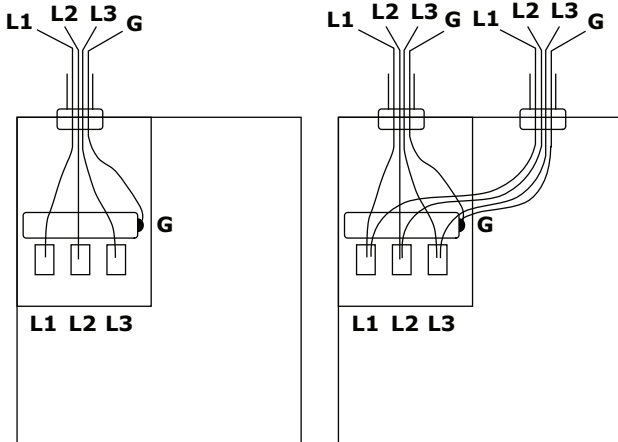

Circuit Breakers and Fused Disconnects

Any field-supplied circuit breaker or fused disconnect installed in power supplied to the chiller must be sized in compliance with National Electric Code (NEC) or local guidelines.

CE for Control Power Transformer Option

Important: For the Control Power Transformer (CPTR) option, chiller-mounted/UPS power, the customer needs to ensure that the supply is NOT taken from public low voltage supplies, and that a dedicated clean source of private power supply is used for chiller-mounted CPTR option when a CE chiller is selected. This also includes when CPTR option is standard such as in customer-supplied starters and remote-mounted medium-voltage Adaptive Frequency™ Drives (AFDs).

All customer wiring, including power wiring to starters/drives/CPTR Option/UPS shore power, needs to be separated: 24–27 Vdc, 110–120 Vac, and 380–600 Vac each need to be in separate conduit runs.

For 110/120 V customer wiring, including main power supply to CPTR option, it is required that the customer provides some sort of surge protection ahead of it, and all customer wiring needs to be run in conduit. Any Ethernet cables being used by customer to interface with the Trane® chiller must be shielded Ethernet cabling.

The customer is required to provide an overcurrent device upstream of the CPTR option in accordance with International Electrotechnical Commission (IEC) standards and/or any applicable local and national codes.

The customer is required to follow all local, national, and/or IEC codes for installation.

Service personnel must use proper PPE for servicing and should also use proper lockout/tagout procedures during servicing. The customer should also disconnect the main supply disconnecting device upstream of the starter or drive first before performing any service on any part of the chiller, including the CPTR option, related controls, and oil pump motor circuits. In addition, service personnel should first disconnect the supply disconnecting device upstream of the CPTR option before performing any service on the CPTR option or its related circuits. Lock the CPTR option enclosure panel disconnect handle before servicing to prevent accidental pulling of the disconnect handle.

CE for Starter or Drive

Important:

- *All Trane-supplied remote starters and drives used in conjunction with CVHH Trane® chillers will be CE-compliant per European Union (EU) directives and International Electrotechnical Commission (IEC) standards to which the CVHH chillers also comply. All Trane-supplied remote starters and drives must be used with CVHH Trane® chillers to ensure CE compliance.*
- *For remote starters and drives, basic details are provided on remote starter/drive nameplate. Please refer to the chiller unit nameplate located on the chiller-mounted control panel for details on wire sizing (minimum current ampacity) and overcurrent protection sizing upstream of the unit (maximum overcurrent protection).*
- *Always refer to as-built schematic wiring diagrams and the chiller Installation, Operation, and Maintenance manual located inside the chiller-mounted control panel (regardless of unit- or remote-mounted starter or drive) for details on wiring, safety, installation, and warnings.*
- *Refer to drive-specific Installation, Operation, and Maintenance manuals for drive and option installation specifics for unit- and remote-mounted adaptive frequency drives.*
- *Customers are responsible for all field wiring with respect to EMC and EMI interference. Customers are responsible to mitigate the risks associated with EMC and EMI interference that can occur as a result of customer-provided field wiring as dictated by local, national, and international codes. This also implies that for remote-mounted starters and drives, customers are responsible for the entire field wiring into the starter/drive as well as between the starter/drive and the chiller/compressor terminals with respect to EMC and EMI interference. It also implies that customers are responsible for incoming power wiring to both the starter/drive and CPTR option enclosure unit-mounted panel with respect to EMC and EMI interference.*

All customer wiring, including power wiring to starters/drives/CPTR Option/UPS shore power, needs to be separated: 24–27 Vdc, 110–120 Vac, and 380–600 Vac each need to be in separate conduit runs.

For 110/120V customer wiring, including power supply to CPTR option, it is required that the customer provides

some sort of surge protection and all customer wiring needs to be run in conduit.

For remote starters interfacing with the Trane® chiller, all wiring needs to be run in conduit. Any Ethernet cables being used by customer to interface with the Trane® chiller must be shielded Ethernet cabling.

The customer is required to provide an overcurrent protective device upstream of all starters and drives in accordance with IEC standards and/or any applicable local and national codes.

Service personnel must use proper PPE for servicing and should also use proper lockout/tagout procedures during servicing: lock the starter disconnect handle before servicing to prevent accidental pulling of disconnect handle at the starter panel. In addition, service personnel should first disconnect the main supply disconnecting device upstream of the starter or drive before performing any service on any part of the chiller.

⚠ WARNING

Lockout/Tagout Before Removing Touch-Safe Covers!

Failure to follow instructions regarding touch-safe covers could result in death or serious injury.

Touch-safe covers inside panels are there for protection and may be removed if necessary for service only and only after disconnection of main power supply. Before removing any touch-safe cover, ensure that there is no line power first. Removal of touch-safe covers is at the customer/service personnel's own risk. After any service is completed, if the touch-safe covers have been removed, they need to be put back in to ensure safety and protection.



Note: Graphic labels (shown above) are used for CE application only.

Important:

- Before servicing, disconnect all power sources and allow at least 30 minutes for capacitors to discharge.
- All electrical enclosures—unit or remote—are IP2X.

For CE units, the convenience outlet in the control panel requires a suitable adaptor to meet the needs of customers with different plug requirements.

Control Power Transformer Option

The Control Power Transformer (CPTR) option provides a means to isolate the incoming line voltage required for the chiller control circuits and the oil/refrigerant pump from the compressor incoming line voltage. The CPTR option provides a solution for customers that cannot afford to lose communication with the chiller or extended restart times due to lost incoming power.

The CPTR option will benefit:

- UPS customers
- Customers requiring fast restarts
- Customers who need controls sourced from a clean dedicated source
- Customers with building automation/communication systems who want to maintain chiller status reporting during power loss
- Chillers with remote-mounted medium-voltage Adaptive Frequency™ Drives (AFDs) or customer-supplied starters

NOTICE

Component Damage!

Failure to follow instructions below could cause an electrical short which could result in component damage.

Remove debris from inside the CPTR option enclosure panel before turning the power on.

The standard unit-mounted CPTR option shall have an enclosure with a disconnect and will require customer-supplied power.

CVHH CenTraVac™ chillers have a low-voltage CPTR option and a medium-voltage CPTR option.

The CPTR option involves a single phase 4kVA transformer(s) and the oil pump motor circuit to be located together in an enclosure that is unit-mounted. There is three-phase line power between 380 to 600 Vac feeding this enclosure. Wherever the 4kVA transformer is located, the oil pump motor circuit will be located along with it.

With the CPTR option, the control power transformer(s) and oil pump motor circuit are NOT inside of the starter.

For the low-voltage CPTR option, the single phase 4kVA transformer feeds the 120V control power to all of the controls. The three-phase line power feeds a motor starter and overload oil pump motor circuit which feeds the three-phase oil pump motor.

For the medium-voltage CPTR option, there are two single-phase 4-kVA transformers: one of the 4kVA transformers feeds the 120V control power to all of the controls. The second transformer feeds a combination motor controller oil pump motor circuit which then feeds a single-phase oil pump motor.

Note: Refer to the unit nameplate for maximum overcurrent protection and minimum current ampacity values for connecting to the CPTR option enclosure.

Service personnel are required to ensure that the incoming power supply voltage provided by the customer to the CPTR option enclosure unit-mounted panel is as per submittal and nameplate.

Power Factor Correction Capacitors (Optional)

Power factor correction capacitors (PFCCs) are designed to provide power factor correction for the compressor motor. PFCCs are available as an option for unit- and remote-mounted starters.

Notes:

- Verify PFCC voltage rating is greater than or equal to the compressor voltage rating stamped on the unit nameplate.
- Refer to the wiring diagrams that shipped with the unit for specific PFCC wiring information.

NOTICE

Motor Damage!

Failure to wire PFCCs into the starter correctly could cause misapplication of these capacitors and result in a loss of motor overload protection and subsequently cause motor damage.



Note: Graphic labels (shown above) are used for CE application only.

Important:

- Before servicing, disconnect all power sources and allow at least 30 minutes for capacitors to discharge.
- All electrical enclosures—unit or remote—are IP2X.

PFCCs must be wired one of two ways as shown as explained in the following figures and accompanying text (Option 1 and Option 2).

Figure 40. Option 1 — PFCCs installed downstream of starter contactor, upstream of current transformers

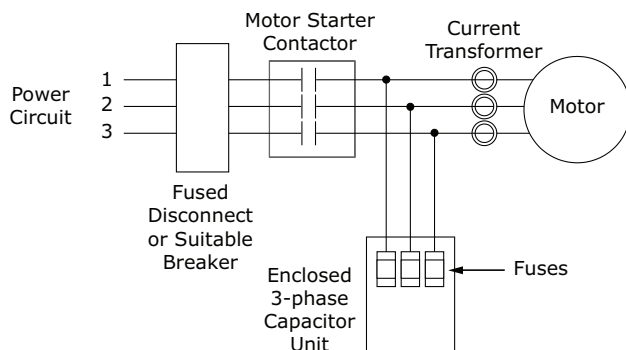

⚠ WARNING

Hazardous Voltage w/Capacitors!

Failure to disconnect power and discharge capacitors before servicing could result in death or serious injury.

Disconnect all electric power, including remote disconnects and discharge all motor start/run capacitors before servicing. Follow proper lockout/tagout procedures to ensure the power cannot be inadvertently energized. For variable frequency drives or other energy storing components provided by Trane or others, refer to the appropriate manufacturer's literature for allowable waiting periods for discharge of capacitors. Verify with a CAT III or IV voltmeter rated per NFPA 70E that all capacitors have discharged.



Note: Graphic labels (shown above) are used for CE application only.

Important:

- Before servicing, disconnect all power sources and allow at least 30 minutes for capacitors to discharge.
- All electrical enclosures—unit or remote—are IP2X.

Simultaneously disconnect capacitors and load from line power. If the capacitors are not switched offline when the load is disconnected, they continue to add capacitance to the electrical distribution system. A leading power factor and too much capacitance may eventually develop. This overprotection causes poor voltage regulation (i.e., voltage is high when the circuit is unloaded, then drops as loads are added).

Power Supply Wiring

Figure 41. Option 2—PFCC wires routed through current transformers

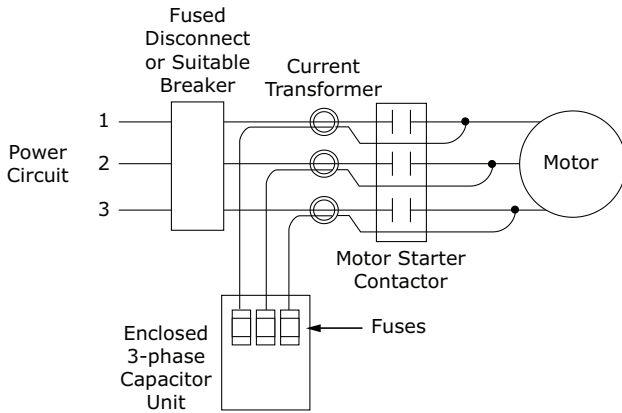

Size motor overload protection to account for capacitor-supplied current. Overloads are typically set to measure the total current drawn by the motor. When PFCCs are used, they become the source of part of that current. If the current they provide is not registered by the overload protectors, potentially damaging amperage can reach the motor. The simplest way to ensure that the overloads detect all current supplied to the motor is to position the PFCCs upstream of the current transformers as shown in the preceding figure (Option 1). If the capacitor connection points are downstream of the current transformers, route the PFCC leads through the current transformers as shown in the preceding figure (Option 2). This ensures that the overloads register both line and capacitor-supplied current.

Interconnecting Wiring

Typical equipment room conduit layouts with and without unit-mounted starters are shown in the following two figures.

Important: *The interconnecting wiring between the starter panel, compressor, and control panel is factory-installed with unit-mounted starters. However, when a remote-mounted starter is used, the interconnecting wiring must be field-installed.*

Note: *Refer to starter submittal drawing for location of incoming wiring to the starter.*

Figure 42. Typical equipment room layout for units with unit-mounted starters

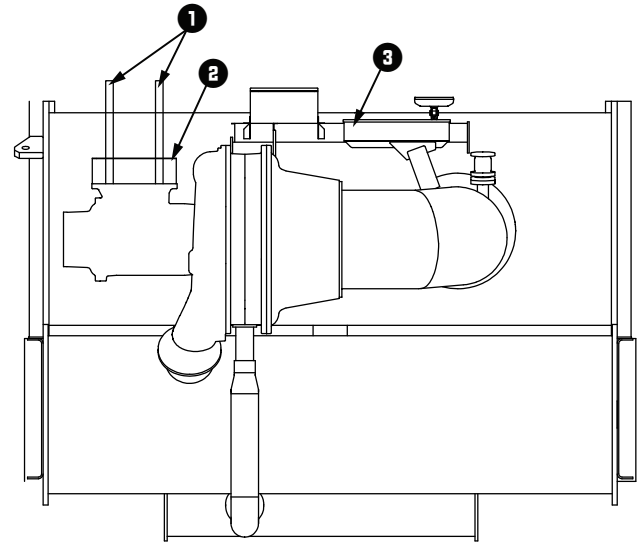

1. Line side power conduits
2. Unit-mounted starter
3. Unit control panel

Figure 43. Typical equipment room layout for units with remote-mounted starters

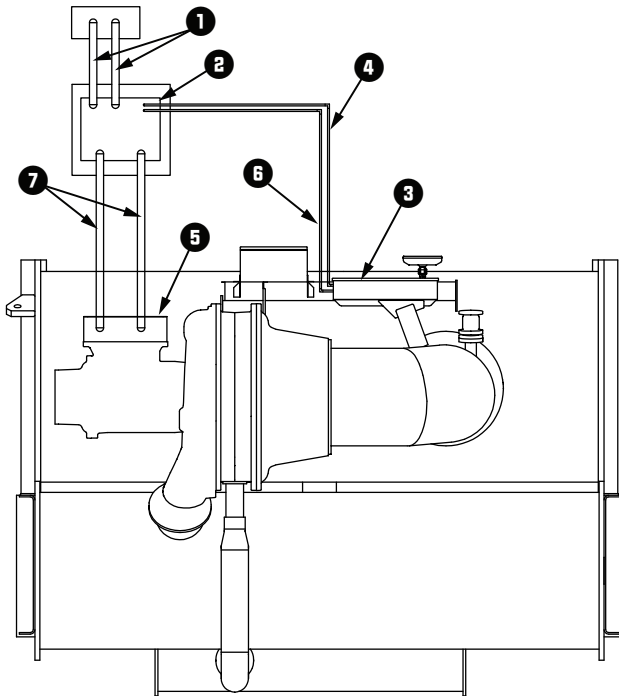

1. Line side power conduits
2. Remote-mounted starter
3. Unit control panel
4. Inter-processor communication (IPC) circuit conduit less than 30V (and current transformer/potential transformer [CT/PT] wiring for starters by others)

Note: Must enter the low voltage Class 2 portion of the unit control panel (1000 feet [304.8 m] maximum).

5. Motor terminal box
6. 115V control conduit

Note: Must enter the higher than 30 Vdc Class 1 portion of the unit control panel.

7. Lead power wiring

Note: Refer to the unit field connection diagram for approximate unit control panel knock out locations. To prevent damage to the unit control panel components, do NOT route control conduit into the top of the box.

Starter to Motor Wiring (Remote-Mounted Starters Only)

Ground Wire Terminal Lugs

Ground wire lugs are provided in the motor terminal box and in the starter panel.

Terminal Clamps

NOTICE

Use Copper Conductors Only!

Failure to use copper conductors could result in equipment damage as the equipment was not designed or qualified to accept other types of conductors.



Note: Graphic labels (shown above) are used for CE application only.

Important:

- Before servicing, disconnect all power sources and allow at least 30 minutes for capacitors to discharge.
- All electrical enclosures—unit or remote—are IP2X.

Terminal clamps are supplied with the motor terminals to accommodate either bus bars or standard motor terminal wire lugs. Terminal clamps provide additional surface area to minimize the possibility of improper electrical connections.

Wire Terminal Lugs

NOTICE

Component Damage!

Failure to ensure the power supply wiring and output to motor wiring are connected to the proper terminals could cause catastrophic failure of the starter and/or motor.

Wire terminal lugs must be field supplied.

- Use field-provided, crimp-type wire terminal lugs properly sized for the application.

Power Supply Wiring

Note: Wire size ranges for the starter line and load-side lugs are listed on the starter submittal drawings supplied by the starter manufacturer or Trane. Carefully review the submitted wire lug sizes for compatibility with the conductor sizes specified by the electrical engineer or contractor.

- On 600V and below, a terminal clamp with a 3/8-in. (9.525-mm) bolt is provided on each motor terminal stud; use the factory-supplied Belleville washers on the wire lug connections. The following figure illustrates the junction between a motor terminal stud and terminal lug.
- Torque for this assembly is 24 ft·lb (32.5 N·m).
- Install but do NOT connect the power leads between the starter and compressor motor. (These connections will be completed under supervision of a qualified Trane service engineer after the pre-start inspection.)

Figure 44. Terminal stud, clamp, and lug assembly (600V and below)

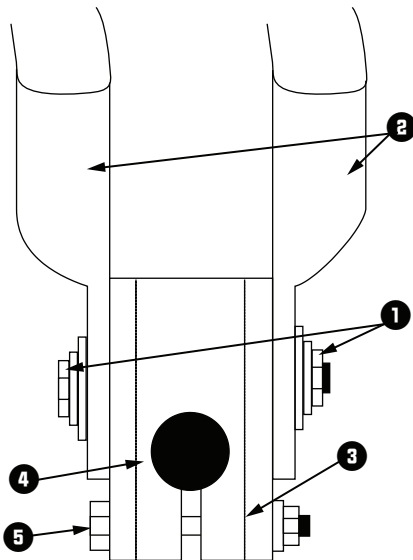

1. Belleville washer
2. Terminal lugs
3. Terminal clamp
4. Motor terminal stud
5. Terminal mounting bolt

Bus Bars

NOTICE

Component Damage!

Failure to follow instructions below could cause an electrical short which could result in component damage.

Remove debris from inside the CPTR option enclosure panel before turning the power on.

Bus bars and extra nuts are available as a Trane option.

Install the bus bars between the motor terminals when using a starter that is:

- A low-voltage Adaptive Frequency™ Drive (AFD)
- Across-the-line
- Primary reactor/resistor
- Autotransformer
- Customer-supplied

Connect T1 to T6, T2 to T4, and T3 to T5.

Note: Bus bars are not needed in medium-voltage or high-voltage applications since only three terminals are used in the motor and starter.

Starter to Control Panel Wiring

The unit submittal includes the field wiring connection diagram and the starter-to-control-panel connection diagram (showing the electrical connections required between the remote-mounted starter and the control panel).

Note: Install separate conduit into the low voltage (30 volts) section of the control panel.

When sizing and installing the electrical conductors for these circuits, follow the guidelines listed. Use 14 AWG for 120V control circuits unless otherwise specified. For AWG/MCM equivalents in mm², refer to the table in “Electrical Requirements,” p. 54.

NOTICE

Adaptive Frequency Drive (AFD)/Starter Component Damage!

Failure to remove debris from inside the AFD/starter panel could result in an electrical short and could cause serious AFD/starter component damage.

Important: Maintain at least 6 in. (16 cm) between low-voltage (less than 30V) and high-voltage circuits. Failure to do so could result in electrical noise that may distort the signals carried by the low-voltage wiring, including the inter-processor communication (IPC) wiring.

To wire the starter to the control panel, use these guidelines:

- If the starter enclosure must be cut to provide electrical access, exercise care to prevent debris from falling inside the enclosure. Do NOT cut the Adaptive Frequency™ Drive (AFD) enclosure.
- Use only shielded, twisted-pair wiring for the inter-processor communication (IPC) circuit between the starter and the control panel on remote-mounted starters.

Note: Recommended wire is Beldon Type 8760, 18 AWG for runs up to 1000 ft (304.8 m). For AWG/MCM equivalents in mm², refer to the table in “Electrical Requirements,” p. 54. The polarity of the IPC wiring is critical for proper operation.

- Separate low-voltage (less than 30V; refer to the table in “Trane-supplied Remote Starter Wiring,” p. 55) wiring from the 115V wiring by running each in its own conduit.
- When routing the IPC circuit out of the starter enclosure, ensure that it is at least 6 in. (16 cm) from all wires carrying a higher voltage.

⚠ WARNING

Proper Field Wiring and Grounding Required!

Failure to follow code could result in death or serious injury.

All field wiring **MUST** be performed by qualified personnel. Improperly installed and grounded field wiring poses **FIRE** and **ELECTROCUTION** hazards. To avoid these hazards, you **MUST** follow requirements for field wiring installation and grounding as described in NEC and your local/state/national electrical codes.



Note: Graphic labels (shown above) are used for CE application only.

Important:

- Before servicing, disconnect all power sources and allow at least 30 minutes for capacitors to discharge.
- All electrical enclosures—unit or remote—are IP2X.
- The IPC wiring shield should be grounded on one end only at control panel end. The other end should be un-terminated and taped back on the cable sheath to prevent any contact between shield and ground.
- Oil Pump Interlock: All starters must provide an interlock (normally open) contact with the chiller oil pump connected to the control panel at terminals 1X1-10 and 1X1-21 (14 AWG; for AWG/MCM equivalents in mm², refer to the table in “Electrical Requirements,” p. 54). The purpose of this interlock is to maintain the oil pump signal in the event that a starter failure, such as welded contacts, keeps the chiller motor running after the controller interrupts the run signal.

Medium Voltage Motor

⚠ WARNING

Hazardous Voltage!

Failure to disconnect power before servicing could result in death or serious injury.

Disconnect all electric power, including remote disconnects before servicing. Follow proper lockout/tagout procedures to ensure the power can not be inadvertently energized. Verify that no power is present with a voltmeter.



Note: Graphic labels (shown above) are used for CE application only.

Important:

- Before servicing, disconnect all power sources and allow at least 30 minutes for capacitors to discharge.
- All electrical enclosures—unit or remote—are IP2X.

All electrical circuits shall be treated as energized until all lockout/tagout procedures are in place and the circuit has been tested to verify that it is de-energized. The medium-voltage motor terminal box cover must NOT be removed if power is present, or if there is a possibility that power may be present. Working on energized medium-voltage circuits is not an approved practice for normal HVAC maintenance or service.

The motor is suitable for remote-mounted across-the-line (including circuit breaker starting), primary reactor, autotransformer, or solid-state starting. Refer to the unit nameplate for motor data including RLA, LRA, etc.

In all cases of non-Trane supplied starters, a disconnecting means and short-circuit protection must be installed ahead of the starter, unless they are included as part of the starter.

Note: Trane assumes no responsibility for the design, documentation, construction, compatibility, installation, start-up, or long term support of starters provided by others.

Motor Terminal Box

A large steel motor terminal box is provided to allow for the field connection of the motor power supply wire to the motor. There are three sizes available depending on voltage and motor frame size.

Figure 45. Motor terminal box dimensions, in. (mm)

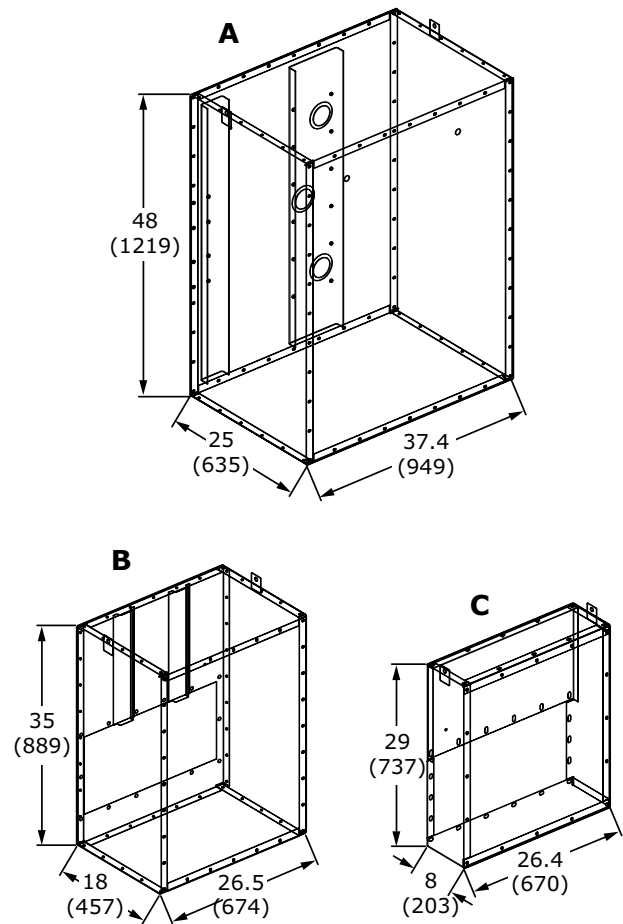

Table 22. Motor terminal box dimensions

	Box Weight		Volt Range
	lb	kg	
A	564 ^(a)	256 ^(a)	6000–13.8kV Frame 6800, 6800L
B	259	117.3	2300–13.8kV Frame 440E, 5000, 5800, 580L
C	129	58.5	380–600 Vac Frame 440E, 5000

Note: Lifting holes are 0.56 in. (14.3 mm).

^(a) Motor terminal box cover-only weight is 55 lb (24.9 kg).

Note: If the box is removed for installation purposes, the motor terminals **MUST** be protected against impact or stress damage. Field fabrication of a cover or guard is required.

- The motor terminal box is large enough to accommodate the use of stress cones.
- If conduit is applied, a flexible connection of the conduit to the box should be made to allow for unit serviceability and for vibration isolation. The cable should be supported or protected against abrasion and wear on any edges or surfaces. Cable or conduit openings can be cut at any location in the box sides, top, or bottom for cable entry. Always ensure that NO debris remains in the box after cutting cable entry holes.

Motor Supply Wiring

⚠ WARNING

Proper Field Wiring and Grounding Required!

Failure to follow code could result in death or serious injury.

All field wiring **MUST** be performed by qualified personnel. Improperly installed and grounded field wiring poses **FIRE** and **ELECTROCUTION** hazards. To avoid these hazards, you **MUST** follow requirements for field wiring installation and grounding as described in **NEC** and your local/state/national electrical codes.



Note: Graphic labels (shown above) are used for CE application only.

Important:

- Before servicing, disconnect all power sources and allow at least 30 minutes for capacitors to discharge.
- All electrical enclosures—unit or remote—are IP2X.

Motor circuit wire sizing by the installer must be made in accordance with the National Electric Code (NEC) or any other applicable codes.

Three terminals are provided on the chiller for the connection of power to the motor from the starter. Power leads to motors must be in multiples of three, with equal phase representation in all conduits or wire trays. To limit the effects of corona or ionization with cables carrying more than 2000V, Trane requires that the power cable have a metallic shield, unless the cable is specifically listed or approved for non-shielded use. If the cable is shielded, the shielding must be grounded at one end (grounding is typically done at the starter or supply end).

Care must be taken while routing the incoming cables to ensure that cable loads or tensions are not applied to the terminal or premature terminal failure could result.

Motor Terminals

Field-provided, ring-type lugs, with no sharp edges or corners, must be used by a qualified installer to connect the power wiring to the motor terminals. Follow all instructions provided with the field-provided lugs to ensure proper connections.

Important: The use of stress cones is highly recommended to reduce and control longitudinal and radial electrical stresses at the cable ends.

Prior to assembly the terminal stud, nuts, and lug should be inspected and cleaned to ensure they are not damaged or contaminated. When attaching starter leads to 2.3 to 6.6 kV



Medium Voltage Motor

motor terminals, the M14x2 brass jam nuts should be tightened to a maximum torque of 24 to 30 ft·lb (32.5 to 40.7 N·m). Always use a second wrench to backup the assembly and prevent applying excessive torque to the terminal shaft.

Note: 6.0 and 6.6kV motors on 6800 or 6800L frames (see compressor model number for motor frame) use the same motor terminals as the 10 to 13.8kV motors.

The motor terminal on a 10 to 13.8kV motor has a copper shaft that is threaded M14 x 2-6 G. Brass nuts are provided on the motor terminals to retain the lugs, and the final connection should be tightened to 24 to 30 ft·lb (32.5 to 40.7 N·m).

NOTICE

Motor Terminal Damage!

Applying torque to the motor terminal when tightening lugs could result in equipment or property-only damage.

Always use a second wrench to back-up the assembly and prevent the application of torque to the terminal shaft.

Before beginning wiring and torquing, ensure proper motor terminal care and do NOT apply any excess stress.

Ground Wire Terminal Lug

A ground wire lug is provided in the motor terminal box to allow the field connection of an earth ground. The lug will accept a field-supplied ground wire of #8 to #2 AWG. For AWG/MCM equivalents in mm², refer to the table in "Electrical Requirements," p. 54. After completing the field connection of wiring, inspect and clean the motor terminals and motor housing, and remove any debris before reinstalling the motor terminal box cover. The cover must be re-installed onto the motor terminal box and all bolts installed. Do NOT operate the chiller with the motor terminal box cover removed or with any loose or missing cover bolts.

CE for Medium Voltage Starter

⚠ WARNING

Hazardous Voltage w/Capacitors!

Failure to disconnect power and discharge capacitors before servicing could result in death or serious injury.

Disconnect all electric power, including remote disconnects and discharge all motor start/run capacitors before servicing. Follow proper lockout/tagout procedures to ensure the power cannot be inadvertently energized. For variable frequency drives or other energy storing components provided by Trane or others, refer to the appropriate manufacturer's literature for allowable waiting periods for discharge of capacitors. Verify with a CAT III or IV voltmeter rated per NFPA 70E that all capacitors have discharged.



Note: Graphic labels (shown above) are used for CE application only.

Important:

- Before servicing, disconnect all power sources and allow at least 10 minutes for capacitors to discharge.
- All electrical enclosures—unit or remote—are IP2X.
- Customers are responsible for all field wiring in compliance with local, national, and/or international codes.
- Any fuses inside the medium-voltage starter enclosure may be energized.
- Power factor correction capacitors (PFCC) fuses must be installed before energizing the medium-voltage starter.
- Do NOT modify or disassemble the medium-voltage starter.
- Use only factory-authorized replacement parts.
- Do NOT install or energize the medium-voltage starter if it has been damaged.
- Contactor must be bolted in place after installation; maximum torque is 14 ft·lb (19.0 N·m).



Note: Graphic labels (shown above) are used for CE application only.

Important: Mounting a motor starter on or over a combustible surface could result in a fire. To minimize the risk of possible fires, a floor plate of at least 0.056 in. (1.43 mm) thick galvanized or 0.63 in. (1.6 mm) thick uncoated steel extending at least 5.9 in. (150 mm) beyond the equipment on all four sides must be used.



System Control Circuit Wiring (Field Wiring)

Table 23. Unit control panel wiring 120 Vac

Standard Control Circuits: Unit Control Panel Control Wiring (120 Vac)	Unit Control Terminations	Input or Output Type	Contacts
Chilled Water Flow Proving Input ^(a)	1X1-5 to 1K16-J3-2	Binary Input	Normally Open, Closure with Flow
Condenser Water Flow Proving Input ^(b)	1X1-6 to 1K16-J2-2	Binary Input	Normally Open, Closure with Flow
Second Condenser Water Flow Proving Input ^(c)	1X1-7 to 1K29-J3-2	Binary Input	Normally Open, Closure with Flow
Chilled Water Pump Relay Output	1K15-J2-4 to 6	Binary Output	Normally Open
Condenser Water Pump Relay Output	1K15-J2-1 to 3	Binary Output	Normally Open
Optional Control Circuits (120 Vac)	Note: Defaults are factory programmed; alternates can be selected at start-up using the service tool.		
Alarm Relay MAR (Non-Latching) Output	1K19-J2-1 to 3	Binary Output	Normally Open
Limit Warning Relay Output	1K19-J2-4 to 6	Binary Output	Normally Open
Alarm Relay MMR (Latching) Output	1K19-J2-7 to 9	Binary Output	Normally Open
Compressor Running Relay Output	1K19-J2-10 to 12	Binary Output	Normally Open
Maximum Capacity Relay Output	1K20-J2-1 to 3	Binary Output	Normally Open
Head Relief Request Relay Output	1K20-J2-4 to 6	Binary Output	Normally Open
Purge Alarm Relay Output	1K20-J2-7 to 9	Binary Output	Normally Open
Ice Building Relay Output	1K15-J2-10 to 12	Binary Output	Normally Open
Free Cooling Relay Output	1K21-J2-4 to 6	Binary Output	Normally Open
Standard Low Voltage Circuits (Less than 30 Vac)^(d)	Unit Control Panel Terminations	Input or Output Type	Contacts
External Auto Stop Input	1K2-J2-1 to 2	Binary Input	Closure Required for Normal Operation
Emergency Stop Input	1K2-J2-3 to 4	Binary Input	Closure Required for Normal Operation
Optional Low Voltage Circuits			
External Base Loading Enable Input	1K8-J2-1 to 2	Binary Input	Normally Open
External Hot Water Control Enable Input	1K8-J2-3 to 4	Binary Input	Normally Open
External Ice Building Control Enable Input	1K9-J2-1 to 2	Binary Input	Normally Open
External Free Cooling Input Enable Input	1K10-J2-1 to 2	Binary Input	Normally Open
% RLA Compressor Output	1K5-J2-1 to 3	Analog Output	2–10 Vdc
External Condenser Pressure Output	1K5-J2-4 to 6	Analog Output	2–10 Vdc
Evaporator/Condenser Differential Pressure Output	1K5-J2-4 to 6	Analog Output	2–10 Vdc
Condenser Head Pressure Control	1K5-J2-4 to 6	Analog Output	2–10 Vdc
External Demand Limit Setpoint Input	1K6-J2-2 to 3	Analog Input	2–10 Vdc, or 4–20 mA
External Chilled Water Setpoint Input	1K6-J2-5 to 6	Analog Input	2–10 Vdc, or 4–20 mA
External Base Loading Setpoint Input	1K7-J2-2 to 3	Analog Input	2–10 Vdc, or 4–20 mA
Generic Refrigerant Monitor Input	1K7-J2-5 to 6	Analog Input	2–10 Vdc, or 4–20 mA
Outdoor Air Temperature Sensor	Inter-processor Communication (IPC) Bus Connection and Sensor	Communication and Sensor	
BACnet [®] or MODBUS [®]	1K1-P1	Communication to BACnet [®] or MODBUS [®]	(As Ordered; See Sales Order)
LON Interface	1K25	Communication to LonTalk [®]	(As Ordered; See Sales Order)

Note: All wiring to be in accordance with National Electrical Code (NEC) and any local codes.

- (a) If the Chilled Water Flow Proving Input is a factory-installed ifm efector flow-sensing device, the secondary field device (recommended with 38°F [3.3°C] and lower leaving chilled water temperatures) for proof of flow connects from 1X1-5 to 1K26-4 (binary input; normally open, closure with flow). Remove factory jumper when used.
- (b) If the Condenser Water Flow Proving Input is a factory-installed ifm efector flow-sensing device, the secondary (optional) field device for proof of flow connects from 1X1-6 to 1K27-4 (binary input; normally open, closure with flow). Remove factory jumper when used.
- (c) If the Second Condenser Water Flow Proving Input is a factory installed ifm efector flow-sensing device, the secondary (optional) field device for proof of flow connects from 1X1-8 to 1K28-4 (binary input; normally open, closure with flow). Remove factory jumper when used.
- (d) Standard low-voltage circuits (less than 30 Vac) must be separated from 120 Vac or higher wiring.

Water Pump Interlock Circuits and Flow Switch Input

⚠ WARNING

Hazardous Voltage!

Failure to disconnect power before servicing could result in death or serious injury.

Disconnect all electric power, including remote disconnects before servicing. Follow proper lockout/tagout procedures to ensure the power can not be inadvertently energized. Verify that no power is present with a voltmeter.



Note: Graphic labels (shown above) are used for CE application only.

Important:

- Before servicing, disconnect all power sources and allow at least 30 minutes for capacitors to discharge.
- All electrical enclosures—unit or remote—are IP2X.

Note: The circuits for the chilled water proof of flow and the condenser water proof of flow do NOT require external power. Refer to the wiring diagrams that shipped with the chiller.

Chilled Water Pump

1. Wire the evaporator water pump contactor (5K42) to a separate 120 volt single-phase power supply with 14 AWG, 600V copper wire. For AWG/MCM equivalents in mm², refer to the table in “[Electrical Requirements](#),” p. 54.
2. Connect circuit to 1K15-J2-6.
3. Use 1K15-J2-4 120 Vac output to allow the control panel to control the evaporator water pump, or wire the 5K1 contactor to operate remotely and independently of the control panel.

Chilled Water Proof of Flow

When this circuit is installed properly and the evaporator pump is running and providing the required minimum flow, this circuit will prove the evaporator water flow for the chiller controls. Proof of evaporator water flow is required before the start sequence will be allowed to proceed and a loss of evaporator water flow during chiller operation will result in a chiller shutdown.

Refer to as-built schematics on the inside of the control panel for field wiring. This is a dry binary input; normally-open, closure for flow. Apply no external power.

1. With factory-installed ifm efector[®] flow-sensing devices, a field-provided secondary flow-sensing device is recommended with applications having 38°F (3.3°C) and below leaving evaporator water temperatures. When a secondary flow-sensing device is used, remove the factory jumper and install its contacts between 1X1-5 to 1K26-4; this places the secondary flow sensing device in series with the ifm efector[®] flow-sensing device.
2. For field-provided primary proof of flow devices, connect the primary proof of flow device between terminals 1X1-5 to 1K16-J3-2. A secondary field device is recommended with applications having 38°F (3.3°C) and below leaving evaporator water temperatures, and must be field-wired in series with the primary proof of flow device.

Condenser Water Pump

1. Wire the condenser water pump contactor (5K43) to a

separate 120-volt, single-phase power supply with 14 AWG, 600-volt copper wire. For AWG/MCM equivalents in mm², refer to the table in “[Electrical Requirements](#),” p. 54.

2. Connect circuit to control panel terminals 1K15-J2-3.
3. Use 1K15-J2-1 120 Vac output to allow the control panel to control the condenser pump.

Condenser Water Proof of Flow

When this circuit is installed properly and the condenser pump is running and providing the required minimum condenser water flow, this circuit will prove the condenser water flow for the chiller controls. Proof of condenser water flow is also required for the start sequence will be allowed to proceed and a loss of condenser water flow during chiller operation will result in a chiller shutdown.

Refer to as-built schematics on the inside of the control panel for field wiring. This is a dry binary input; normally-open, closure for flow. Apply no external power.

1. With factory-installed ifm efector[®] flow-sensing devices, a secondary field-provided flow-sensing device is optional. When a secondary flow-sensing device is used, remove the factory jumper, and install its contacts between 1X1-5 to 1K27-4; this places the secondary flow sensing device in series with the ifm efector[®] flow-sensing device.
2. For field-provided primary proof of flow devices, connect the primary proof of flow device between terminals 1X1-6 to 1K16-J2-2. The secondary field provided flow sensing device is optional; however, when it is present, it must be field-wired in series with the primary proof of flow device.

Sensor Circuits

All sensors are factory-installed except the optional outdoor air temperature sensor (refer to the following figure for sensor locations). This sensor is required for the outdoor air temperature type of chilled water reset. Use the following guidelines to locate and mount the outdoor air temperature sensor. Mount the sensor probe where needed; however, mount the sensor module in the control panel.



System Control Circuit Wiring (Field Wiring)

Figure 46. Device locations

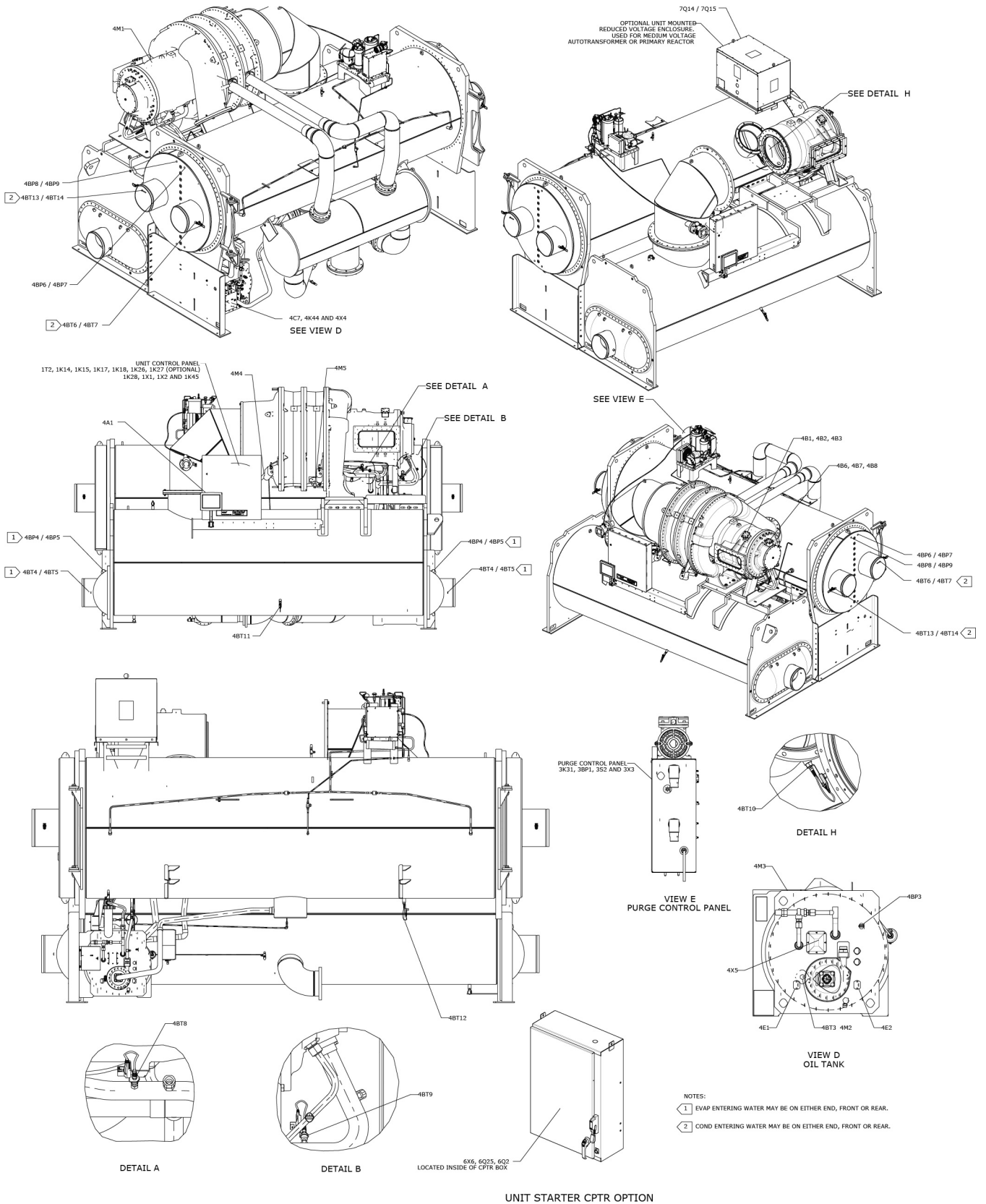

Figure 47. Device designators

DEVICE DESIGNATION	DEVICE LEGEND DESCRIPTION	DEVICE TYPE
4A1	ADAPTIVIEW DISPLAY MODULE	DISPLAY MONITOR
4B1	MOTOR WINDING TEMPERATURE 1	SENSOR - TEMP
4B2	MOTOR WINDING TEMPERATURE 2	SENSOR - TEMP
4B3	MOTOR WINDING TEMPERATURE 3	SENSOR - TEMP
4BP2	OIL PUMP DISCHARGE PRESSURE TRANSDUCER	SENSOR - PRESS TRANSDUCER
4BP3	OIL TANK PRESSURE TRANSDUCER	SENSOR - PRESS TRANSDUCER
4BP4	EVAPORATOR ENTERING WATER PRESSURE TRANSDUCER (OPTIONAL)	SENSOR - PRESS TRANSDUCER
4BP5	EVAPORATOR LEAVING WATER PRESSURE TRANSDUCER (OPTIONAL)	SENSOR - PRESS TRANSDUCER
4BP6	CONDENSER ENTERING WATER PRESSURE TRANSDUCER (OPTIONAL)	SENSOR - PRESS TRANSDUCER
4BP7	CONDENSER LEAVING WATER PRESSURE TRANSDUCER (OPTIONAL)	SENSOR - PRESS TRANSDUCER
4BP8	CONDENSER ENTERING WATER PRESSURE TRANSDUCER (OPTIONAL)	SENSOR - PRESS TRANSDUCER
4BP9	CONDENSER LEAVING WATER PRESSURE TRANSDUCER (OPTIONAL)	SENSOR - PRESS TRANSDUCER
4BT10	COMPRESSOR DISCHARGE REFRIGERANT TEMPERATURE SENSOR	SENSOR - TEMP
4BT11	EVAPORATOR SATURATED REFRIGERANT TEMPERATURE SENSOR	SENSOR - TEMP
4BT12	CONDENSER SATURATED REFRIGERANT TEMPERATURE SENSOR	SENSOR - TEMP
4BT13	SECOND CONDENSER ENTERING WATER TEMPERATURE SENSOR (USED ON HTRC)	SENSOR - TEMP
4BT14	SECOND CONDENSER LEAVING WATER TEMPERATURE SENSOR (USED ON HTRC)	SENSOR - TEMP
4BT3	OIL TANK TEMPERATURE SENSOR	SENSOR - TEMP
4BT4	EVAPORATOR ENTERING WATER TEMPERATURE SENSOR	SENSOR - TEMP
4BT5	EVAPORATOR LEAVING WATER TEMPERATURE SENSOR	SENSOR - TEMP
4BT6	CONDENSER ENTERING WATER TEMPERATURE SENSOR	SENSOR - TEMP
4BT7	CONDENSER LEAVING WATER TEMPERATURE SENSOR	SENSOR - TEMP
4BT8	INBOARD BEARING TEMPERATURE SENSOR	SENSOR - TEMP
4BT9	OUTBOARD BEARING TEMPERATURE SENSOR	SENSOR - TEMP
4E1	OIL TANK HEATER 1	HEATER
4E2	OIL TANK HEATER 2	HEATER
4M1	COMPRESSOR MOTOR	MOTOR
4M2	OIL / REFRIGERANT PUMP MOTOR	MOTOR
4M3	OIL COOLING SOLENOID VALVE	VALVE
4M4	INLET GUIDE VANE FIRST STAGE ACTUATOR	MOTOR - LINEAR
4M5	INLET GUIDE VANE SECOND STAGE ACTUATOR	MOTOR - LINEAR
4X4	OIL / REFRIGERANT CONTROL JUNCTION BOX TERMINAL BLOCK	TERM BLOCK
4X5	OIL / REFRIGERANT PUMP MOTOR TERMINAL BLOCK (3-PRONG MOTOR CONN)	TERM BLOCK
4B6	OUTBOARD BEARING PAD TEMPERATURE SENSOR 1	SENSOR - TEMP
4B7	OUTBOARD BEARING PAD TEMPERATURE SENSOR 2	SENSOR - TEMP
4B8	OUTBOARD BEARING PAD TEMPERATURE SENSOR 3	SENSOR - TEMP
3K31	PURGE LIQUID LEVEL SWITCH INPUT	LLID BOARD
3S2	CONDENSER HIGH PRESSURE CUTOUT SWITCH	SWITCH - PRESS
3X3	PURGE CONTROL PANEL TERMINAL BLOCK	TERM BLOCK
1K14	CONDENSER HIGH PRESSURE CUTOUT SWITCH AND HOT GAS BYPASS VALVE CLOSED INPUTS	LLID BOARD
1K15	CONDENSER AND EVAPORATOR WATER PUMPS AND ICE BUILDING RELAYS	LLID BOARD
1K17	OIL/REFRIGERANT PUMP MOTOR STARTER, OIL COOLING SOLENOID AND OIL TANK HEATER RELAYS	LLID BOARD
1K18	MOTOR WINDING TEMPERATURE 1, 2 AND 3 INPUTS	LLID BOARD
1K26	EVAPORATOR WATER FLOW DETECTION CONTROLLER	FLOW DETECTION
1K27	CONDENSER WATER FLOW DETECTION CONTROLLER	FLOW DETECTION
1K28	HEAT RECOVERY WATER FLOW DETECTION CONTROLLER	FLOW DETECTION
1K45	OUTBOARD BEARING PAD TEMPERATURE 1, 2 AND 3 INPUTS	LLID BOARD
1T2	24VDC POWER SUPPLY 1	LLID BOARD
1X1	MAIN CONTROL PANEL TERMINAL BLOCKS	TERM BLOCK
1X2	MAIN CONTROL PANEL TERMINAL BLOCKS	TERM BLOCK
7Q14	RUN CONTACTOR (AUTO-TRANSFORMER/PRIMARY REACTOR)	CONTACTOR
7Q15	SHORTING CONTACTOR (AUTO-TRANSFORMER ONLY)	CONTACTOR
4C7	OIL / REFRIGERANT PUMP MOTOR START CAPACITOR (ECTV MV ONLY - OIL TANK J-BOX)	CAPACITOR
4K44	OIL / REFRIGERANT PUMP MOTOR START RELAY (ECTV MV ONLY - OIL TANK J-BOX)	RELAY
3BP1	CONDENSER REFRIGERANT PRESSURE TRANSDUCER	SENSOR - PRESS TRANSDUCER
6X6	CONTROL POWER TRANSFORMER TERMINAL BLOCK (CPTR ENCLOSURE)	TERM BLOCK
6Q25	OIL / REFRIGERANT PUMP MOTOR STARTER (CPTR - LV UNITS - 3PH PUMP)	MOTOR CONTROLLER
6Q2	OIL / REFRIGERANT PUMP MOTOR CONTROLLER WITH MANUAL DISCONNECT (CPTR MV)	MOTOR CONTROLLER



System Control Circuit Wiring (Field Wiring)

CWR – Outdoor Option

The outdoor temperature sensor is similar to the unit-mounted temperature sensors in that it consists of the sensor probe and the module. A four-wire inter-processor communication (IPC) bus is connected to the module for 24 Vdc power and the communications link. Trane recommends mounting the sensor module within the control panel and the sensor two wire leads be extended and routed to the outdoor temperature sensor probe sensing location. This ensures the four-wire inter-processor control (IPC) bus protection and provides access to the module for configuration at start-up.

The sensor probe lead wire between the sensor probe and the module can be separated by cutting the two-wire probe lead leaving equal lengths of wire on each device: the sensor probe and the sensor module.

Note: *This sensor and module are matched and must remain together or inaccuracy may occur.*

These wires can then be spliced with two 14 to 18 AWG 600V wires of sufficient length to reach the desired outdoor location with a maximum length 1000 ft (304.8 m). For AWG/MCM equivalents in mm², refer to the table in “Electrical Requirements,” p. 54. The module four-wire bus must be connected to the control panel four-wire bus using the Trane-approved connectors provided.

The sensor will be configured (given its identity and become functional) at start-up when the Trane service technician performs the start-up configuration. It will NOT be operational until that time.

Note: *If shielded cable is used to extend the sensor leads, be sure to cover the shield wire with tape at the junction box and ground it at the control panel. If the added length is run in conduit, do NOT run them in the same conduit with other circuits carrying 30 or more volts.*

Important: *Maintain at least 6 in. (15.24 cm) between low-voltage (less than 30V) and high voltage circuits. Failure to do so could result in electrical noise that may distort the signals carried by the low-voltage wiring, including the IPC.*

Optional Control and Output Circuits

Install various optional wiring as required by the owner's specifications (refer to “System Control Circuit Wiring (Field Wiring),” p. 71).

Starter Module Configuration

The starter module configuration settings will be checked (and configured for remote starters) during start-up commissioning.

Note: *To configure starter modules and perform other starter checks, it is recommended that the line voltage three-phase power be turned off and secured (locked out), and then that a separate source control power (115 Vac) be utilized to power up the control circuits.*

Use the as-built starter schematic to ensure correct fuse and terminals. Verify that the correct fuse is removed and that the control circuit connections are correct; then apply the 115 Vac separate source power to service the controls.

Schematic Wiring Drawings

Please refer to the submittals and drawings that shipped with the unit. Additional wiring drawings for CenTraVac™ chillers are available from your local Trane office.

Operating Principles

General Requirements

Operation and maintenance information are covered in this section. This includes both 50 and 60 Hz centrifugal chillers equipped with the Tracer[®] Symbio[™] 800 control system. This information pertains to all chiller types unless differences exist, in which case the sections are listed by chiller type as applicable and described separately. By carefully reviewing this information and following the instructions given, the owner or operator can successfully operate and maintain the chiller. If mechanical problems do occur, however, contact a Trane service technician to ensure proper diagnosis and repair of the unit.

Important: Although CenTraVac[™] chillers can operate through surge, it is NOT recommended to operate them through repeated surges over long durations. If repeated surges of long durations occur, contact your Trane Service Agency to resolve the issue.

Cooling Cycle

When in the cooling mode, liquid refrigerant is distributed along the length of the evaporator and sprayed through small holes in a distributor (i.e., running the entire length of the shell) to uniformly coat each evaporator tube. Here, the liquid refrigerant absorbs enough heat from the system water circulating through the evaporator tubes to vaporize. The gaseous refrigerant is then drawn through the eliminators (which remove droplets of liquid refrigerant from the gas) and the first-stage variable inlet guide vanes, and into the first-stage impeller.

CVHH 3-Stage Compressor

Compressed gas from the first-stage impeller flows through the fixed, second-stage inlet vanes and into the second-stage impeller. Here, the refrigerant gas is again compressed, and then discharged through the third-stage variable guide vanes and into the third-stage impeller. After the gas is compressed a third time, it is discharged into the condenser. Baffles within the condenser shell distribute the compressed refrigerant gas evenly across the condenser tube bundle. Cooling tower water circulated through the condenser tubes absorbs heat from the refrigerant, causing it to condense. The liquid refrigerant then passes through an orifice plate and into the economizer.

The economizer reduces the energy requirements of the refrigerant cycle by eliminating the need to pass all gaseous refrigerant through three stages of compression (refer to the following figure). Notice that some of the liquid refrigerant flashes to a gas because of the pressure drop created by the orifice plates, thus further cooling the liquid refrigerant. This flash gas is then drawn directly from the first and second stages of the economizer into the third- and second-stage impellers of the compressor, respectively. All remaining liquid refrigerant flows through another orifice plate to the evaporator.

Figure 48. Pressure enthalpy curve, 3-stage

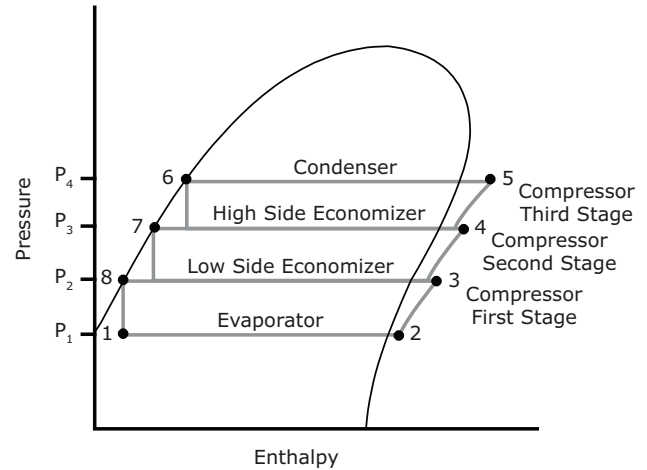
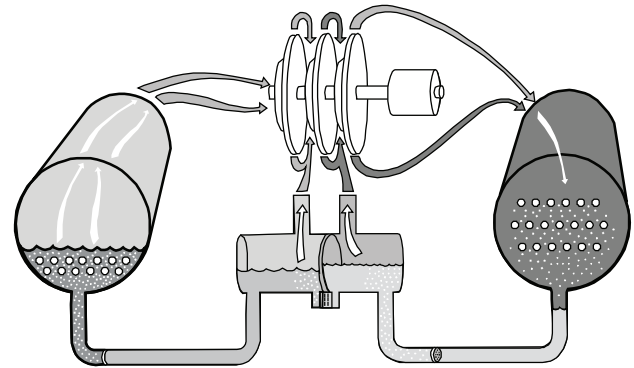

Figure 49. Refrigerant flow, 3-stage



CVHH 2-Stage Compressor

Compressed gas from the first-stage impeller is discharged through the fixed, second-stage variable guide vanes and into the second-stage impeller. Here, the refrigerant gas is again compressed, and then discharged into the condenser. Baffles within the condenser shell distribute the compressed refrigerant gas evenly across the condenser tube bundle. Cooling tower water circulated through the condenser tubes absorbs heat from the refrigerant, causing it to condense. The liquid refrigerant then passes through an orifice plate and into the economizer.

The economizer reduces the energy requirements of the refrigerant cycle by eliminating the need to pass all gaseous refrigerant through both stages of compression (refer to the following figure). Notice that some of the liquid refrigerant flashes to a gas because of the pressure drop created by the orifice plate, thus further cooling the liquid refrigerant. This flash gas is then drawn directly from the economizer into the second-stage impellers of the compressor. All remaining liquid refrigerant flows out of the economizer, passing through another orifice plate and into the evaporator.

Figure 50. Pressure enthalpy curve

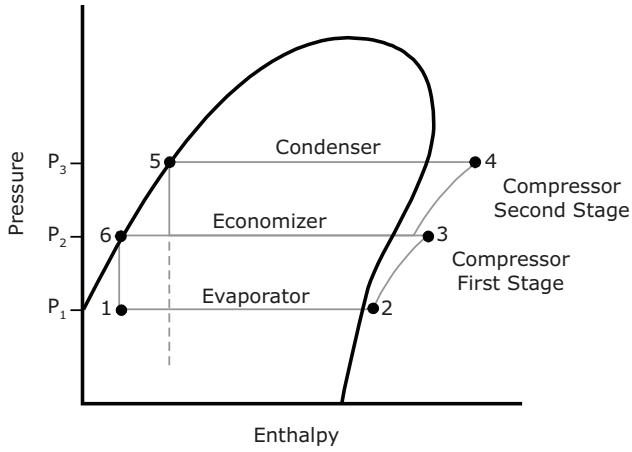
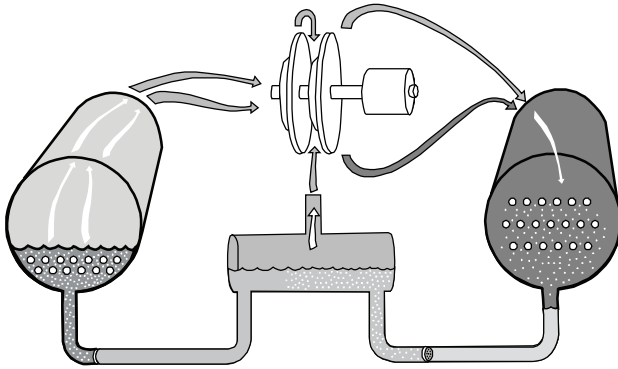

Figure 51. Refrigerant flow, 2-stage



Oil and Refrigerant Pump

Compressor Lubrication System

A schematic diagram of the compressor lubrication system is illustrated in the following figure. Oil is pumped from the oil tank (by a pump and motor located within the tank) through an oil pressure regulating valve designed to maintain a net oil pressure of 20 to 24 psid (137.9 to 165.5 kPaD). It is then filtered and sent to the braze plate heat exchanger oil cooler located above the oil tank and on to the compressor motor bearings. From the bearings, the oil drains back to the oil tank.

Figure 52. Oil refrigerant pump

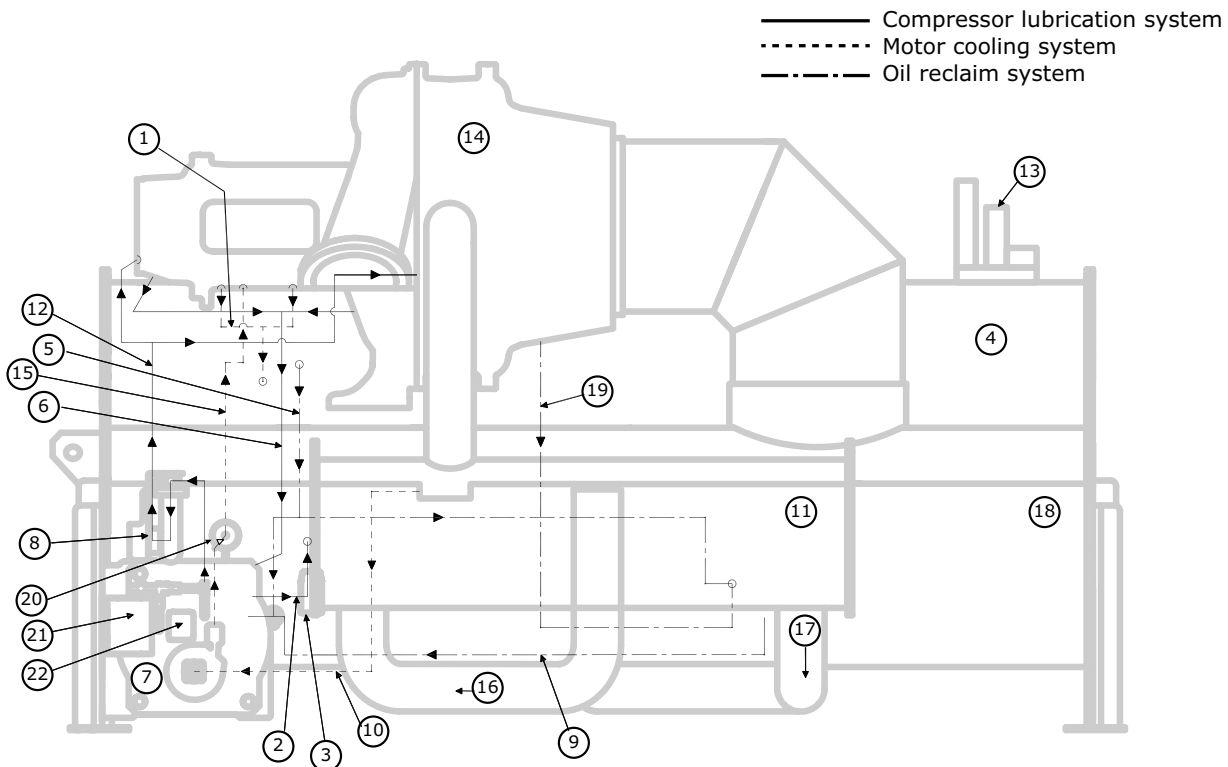

1. Motor coolant return to condenser, 2.125 in. (53.975 mm) OD
2. Oil tank vent line, 2.125 in. (53.975 mm) OD
3. Vent line actuated ball valve
4. Condenser
5. High pressure condenser gas to drive oil reclaim eductors, 0.375 in. (9.525 mm) OD
6. Oil return to tank
7. Oil tank
8. Oil cooler braze plate heat exchanger
9. Oil reclaim from evaporator (second eductor), 0.25 in. (6.35 mm) OD
10. Liquid refrigerant to pump, 1.625 in. (41.275 mm) OD
11. Economizer
12. Oil supply to bearings, 0.875 in. (22.225 mm) OD
13. Purge
14. Compressor
15. Liquid refrigerant motor coolant supply, 1.125 in. (28.575 mm) OD
16. Liquid refrigerant to economizer
17. Liquid refrigerant to evaporator
18. Evaporator
19. Oil reclaim from suction cover (first eductor), 0.25 in. (6.35 mm) OD
20. Motor coolant filter
21. Oil tank junction box enclosure
22. Oil pump motor terminal box

⚠ CAUTION

Hot Surface!

Failure to follow instructions below could result in moderate injury.

Surface temperatures can reach 150°F (66°C). To avoid possible skin burns, stay clear of these surfaces. If possible, allow surfaces to cool before servicing. If servicing is necessary while surface temperatures are still elevated, you **MUST** put on all Personal Protective Equipment (PPE).

⚠ WARNING

Hazardous Voltage in Oil Tank Junction Box Enclosure and Oil Pump Motor Terminal Box!

Failure to disconnect main power and/or auxiliary control power before opening oil tank junction box enclosure or any other junction box/terminal box/panel on the chiller can result in death or serious injury.

Disconnect all power and apply lockout/tagout devices. Follow all company procedures for lockout/tagout. Unit must be tested to ensure a zero energy state and equipment must be put in an electrically safe work condition prior to maintenance. Hazardous voltage up to 600 Vac is present in the oil tank junction box enclosure and oil pump motor terminal box.

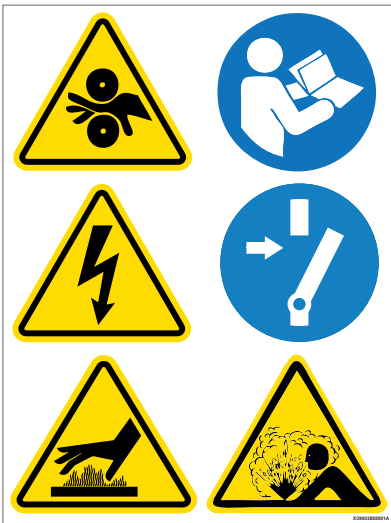

Note: Graphic labels (shown above) are used for CE application only.

Important:

- Before servicing, disconnect all power sources and allow at least 30 minutes for capacitors to discharge.
- All electrical enclosures—unit or remote—are IP2X.

To ensure proper lubrication and prevent refrigerant from condensing in the oil tank, two 750-watt heaters are in wells in the oil tank and are used to heat the oil while the unit is off. With the default settings, the oil heaters are de-energized when the unit starts. The heaters energize as needed to maintain 128°F to 133°F (53.3°C to 56.1°C) when the chiller is not running.

When the chiller is operating, the temperature of the oil tank is typically 100°F to 140°F (37.8°C to 60.0°C). The oil return lines are routed into a separation chamber in the oil tank. Gas flow exits out the top of the oil tank and is vented to the evaporator.

A dual eductor system, using high pressure condenser gas, reclaims oil from the suction cover and the evaporator. The suction cover eductor is discharged into the evaporator, and the evaporator eductor is discharged into the oil tank. The evaporator eductor line has a shut-off valve mounted on the evaporator. The position of the shut-off valve will be set at two turns open during commissioning but may be adjusted later by a qualified technician as necessary for oil return. A normal operating setting for the valve may range from full closed to full open.

Oil supply to both the thrust bearing and journal bearings is cooled when the oil tank temperature reaches 140°F (60.0°C). The supply oil and liquid refrigerant are pumped to a brazed plate heat exchanger. The unit controller monitors oil tank temperature and opens a solenoid valve to allow liquid refrigerant to flow into the heat exchanger.

Motor Cooling System

Compressor motors are cooled with liquid refrigerant (refer to the figure in “Compressor Lubrication System,” p. 78). The refrigerant pump is located on the front of the oil tank (motor inside the oil tank). The refrigerant pump inlet is connected to the well at the bottom of the condenser. The well design ensures preferential supply of liquid refrigerant to the refrigerant pump before refrigerant is supplied to the economizer. Refrigerant is delivered to the motor via the pump. An in-line filter is installed (replace the in-line filter only with major service). Motor refrigerant drain lines are routed to the condenser.

Tracer® AdaptiView™ Display

Information is tailored to operators, service technicians, and owners.

When operating a chiller, specific information is needed you needed on a day-to-day basis—setpoints, limits, diagnostic information, and reports.

Day-to-day operational information is presented at the display. Logically organized groups of information—chiller modes of operation, active diagnostics, settings, and reports put information conveniently at your fingertips. For more information, refer to *Tracer® AdaptiView™ Display for Water-cooled CenTraVac™ Chillers with Symbio™ Controls User Guide* (CTV-SVU004*-EN).

RuptureGuard

Operation

The rupture disk monitors the pressure inside the chiller. If the pressure exceeds the disk's burst setting, the disk ruptures, allowing the chiller pressure to enter the valve holder compartment upstream of the relief valve. If the pressure is above the pressure setting of the relief valve, the valve will open, allowing only the amount of refrigerant to escape to keep the pressure within safe operating limits.

The excess flow valve maintains the downstream side of the rupture disk at atmospheric pressure to assure proper operating conditions for the disk. When the disk bursts, the rapid pressure increase causes the excess flow valve to seal and the valve holder area becomes pressurized.

A disk rupture will be indicated by a pressure reading on the gauge and the pressure switch contacts will close. The pressure switch is an optional accessory and does not wire to the control panel. The pressure switch can be connected to a customer-supplied building automation system (BAS).

EarthWise Purge

General Information

Centrifugal chillers that use low-pressure refrigerants, such as R-1233zd, operate with areas of the chiller at less than atmospheric pressure. Non-condensables in the air, such as water and nitrogen vapor, may leak into these low-pressure areas and accumulate in the condenser. If these non-condensables are not removed, the condenser loses its ability to condense refrigerant efficiently and the pressure of the condenser increases. Increased condenser pressure lowers the chiller's efficiency and capacity.

A purge system is required on low-pressure centrifugal chillers. It is a device that is externally mounted on the

chiller. Its purpose is to remove non-condensable materials that have leaked into the machine.

Note: For convenience, the term "air" is often used in describing non-condensables removed by the purge system, although any other non-condensable materials that may exist in the chiller are also removed by the purge system.

How a Purge System Works

From a functional standpoint, the purge system can be divided into subsystems of components. This section identifies and describes the function of these subsystems.

Refrigeration Circuit Subsystem

The purge evaporator of the refrigeration circuit is located in the purge tank. The purge tank is connected to the chiller condenser by supply and return lines through which chiller refrigerant can freely flow.

The purge evaporator coil presents a cold condensing surface to the chiller refrigerant entering the purge tank. When the purge refrigeration system is running, refrigerant from the chiller condenser is attracted to the cold surface of the purge evaporator. When the gaseous refrigerant contacts the surface of the purge evaporator coil, it condenses into a liquid, leaving a partial vacuum behind. More refrigerant vapor from the chiller condenser migrates to the purge tank to fill the vacuum.

The liquid refrigerant that has condensed in the purge tank returns to the chiller condenser through the liquid return line. The return line includes a filter-drier and a moisture-indicating sight glass.

The condensing unit is air-cooled and is operable whether the chiller is running or not. No additional cooling source is required.

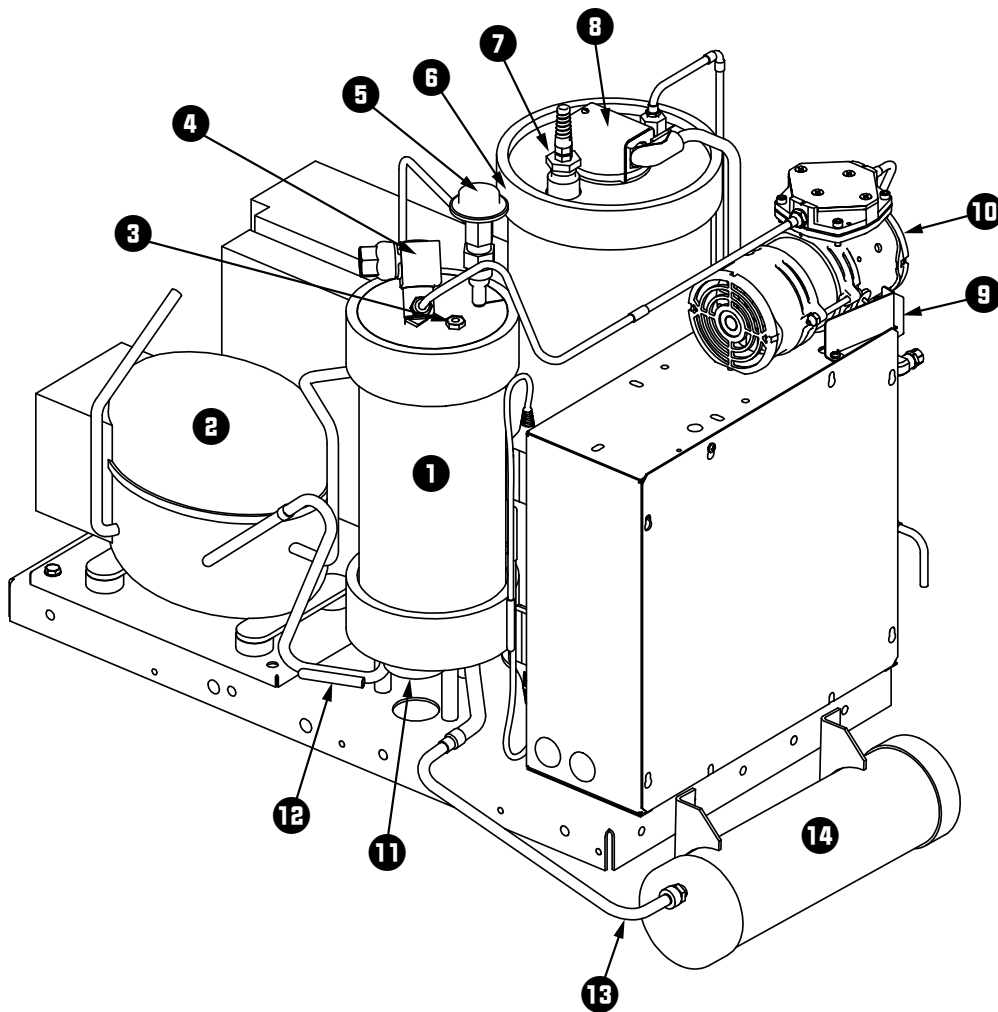

1. Purge tank
2. Condensing unit (includes compressor, condenser coil, and fan)
3. Pressure-relief device (fusible plug)
4. Pump-out solenoid valve
5. Automatic expansion valve
6. Carbon tank
7. Carbon tank temperature sensor
8. Carbon tank heater
9. Exhaust solenoid valve
10. Pump-out compressor
11. Float switch
12. Compressor suction temperature sensor
13. Chiller refrigerant return line
14. Filter-drier canister

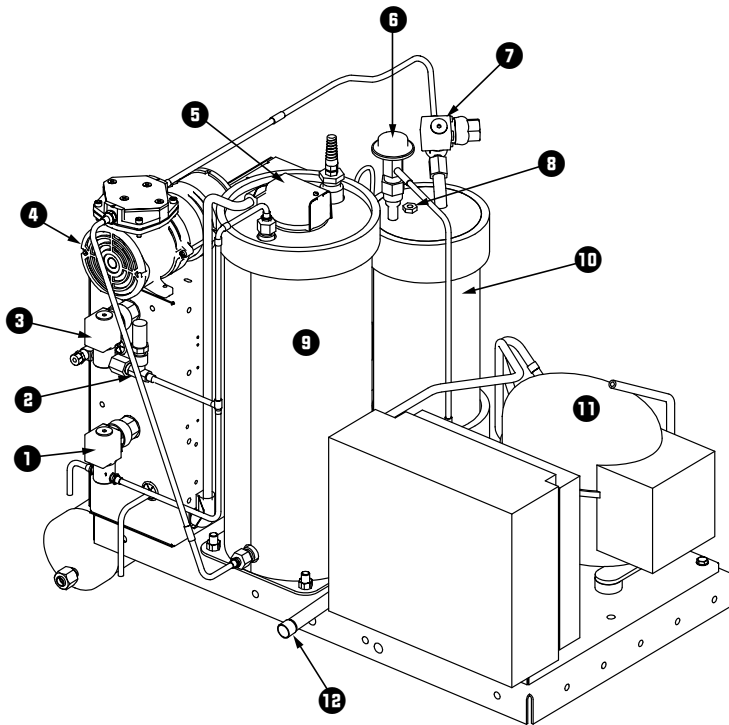

1. Regeneration solenoid valve
2. Pressure-relief valve
3. Exhaust solenoid valve
4. Pump-out compressor
5. Carbon tank heater
6. Automatic expansion valve
7. Pump-out solenoid valve
8. Pressure-relief device (fusible plug)
9. Carbon tank
10. Purge tank
11. Condensing unit
12. Chiller refrigerant supply line

Purge Tank Subsystem

Any non-condensables that have accumulated from the refrigerant vapor are left behind to collect in the purge tank. As the quantity of non-condensables increases, the heat transfer efficiency of the purge evaporator coil is reduced, causing the purge compressor suction temperature to decrease.

A float switch, mounted in the bottom of the purge tank, indicates if there is excessive accumulation of liquid refrigerant in the tank. A liquid level sensor, which resides in the purge control panel, monitors the status of the float switch.

If the normally closed float switch is open for more than 20 minutes, the purge controls will turn off the refrigeration system and generate a non-latching diagnostic—Purge Liquid Level Too High Warning. If the float switch has re-

closed after 20 minutes, the purge controls will restart the refrigeration system.

If the float switch remains open for more than 20 minutes, or if the float switch/liquid level restart cycle has occurred more than four times in four hours, a latching diagnostic—Purge Liquid Level Too High Continuously—will be generated. The purge system will not restart until it is reset.

If a Purge Liquid Level Too High Continuously diagnostic occurs, check the purge lines for any type of restriction (trapped liquid, closed valves, etc.) and ensure that the filter-drier on the liquid return line is in good condition.

A UL-required pressure-relief device (fusible plug), which protects against over-pressurization of the purge tank, is mounted on the purge tank. The plug material will fuse at 210°F (98.9°C), which equates to approximately 132 psig (910.1 kPaG) for refrigerant R-1233zd.



Operating Principles

Pump-out Subsystem

When the purge control subsystem detects the presence of non-condensables in the purge tank, the pump-out solenoid and exhaust solenoid valves open, and the pump-out compressor turns on. The valves and the compressor cycle on and off as needed to achieve an efficient and fast removal of non-condensables.

Note: A High Vacuum Pump option is available for applications that require purge operation at low condensing temperatures and pressures. This option provides a two-stage pump-out compressor. The High Vacuum Pump option allows the purge system to operate to saturation temperatures as low as 34°F (1.1°C). Typical applications that may require the High Vacuum Pump option include free-cooling installations, series chiller installations, ice systems having brine flowing through idle chillers, chillers installed outdoors or in unconditioned spaces, or any application that may cause very low condenser water temperatures.

Carbon Tank and Regeneration Subsystem

The discharge from the pump-out compressor is piped through the carbon tank. The special carbon in the tank effectively scrubs and collects refrigerant molecules from the non-condensable gas before the gas passes through the exhaust solenoid valve to the chiller vent line.

A 175 W resistive heater is mounted inside the carbon tank and is used to periodically “regenerate” the carbon bed and drive any collected refrigerant vapor back into the chiller. A UL-required pressure-relief valve, rated at 150 psig (1034.2 kPaG), is mounted on the line leaving the carbon tank. The valve protects against over-pressurization of the carbon tank.

A temperature sensor is installed through the top of the carbon tank shell so that the controls can monitor the carbon bed temperature. The temperature sensor controls the regeneration cycle and protect against overheating. If the limit temperature is reached, the system shuts down and a Purge Carbon Regen Temperature Limit Exceeded diagnostic is generated.

Sensors

The following sensors are used to enable control communication between the Symbio™ 800 controller and the EarthWise™ purge system. The sensors use low-level intelligence devices (LLIDs) to communicate with the Symbio™ 800 controller.

- **Compressor suction temperature sensor.** This sensor is mounted on the purge condensing unit

suction line. The controller uses the value of this temperature sensor to decide whether or not to purge non-condensables from the purge tank. When the temperature drops to a specified point, the controller activates the pump-out cycle to remove the accumulated non-condensables from the purge tank. When enough non-condensables have been removed and the purge compressor suction temperature increases in response, the controller terminates the pump-out cycle.

- **Saturated condenser temperature sensor.** This sensor is mounted on the chiller. If the chiller is running, the controller uses the value of this temperature sensor to adjust the purge pump-out initiate/terminate setpoints. It may be used to prohibit pump-out if system conditions are too cool.
- **Saturated evaporator temperature sensor.** This sensor is mounted on the chiller. If the chiller is off, the controller uses the value of this temperature sensor to adjust the purge pump-out initiate/terminate setpoints. It may be used to prohibit pump-out if system conditions are too cool.
- **Carbon tank temperature sensor.** This sensor is mounted in the carbon tank of the purge system. It provides feedback to the carbon regeneration algorithm. The sensor and the controller function much the same as a thermostat to control the carbon tank heater.
- **Liquid level sensor.** This sensor resides in the purge control panel. It monitors the status of the normally closed float switch, which is mounted in the bottom of the purge tank. If an adequate amount of liquid fails to drain from the purge tank, the float switch and sensor detect the condition and prevent further purge operation.
- **Condensing unit LLID.** This LLID resides in the purge control panel. It uses a high-power relay to control the operation of the purge condensing unit.
- **Quad relay LLID.** This LLID resides in the purge control panel. It has four relay outputs that are used to control the pump-out compressor, the carbon tank heater, the regeneration solenoid valve, and an alarm output.
- **Dual triac LLID.** This LLID resides in the purge control panel. It has two triac-type outputs that are used to control the pump-out solenoid valve and the exhaust solenoid valve. The purge system draws its control power from the power supplies of the chiller control panel.

Start-Up and Shutdown

This section provides basic information on chiller operation for common events.

Sequence of Operation

Adaptive control algorithms are used on CenTraVac™ chillers. This section illustrates common control sequences.

Software Operation Overview Diagram

The following figure is a diagram of the five possible software states. This diagram can be thought of as a state chart, with the arrows and arrow text, depicting the transitions between states:

- The text in the circles is the internal software designations for each state.

Figure 53. Software operation overview

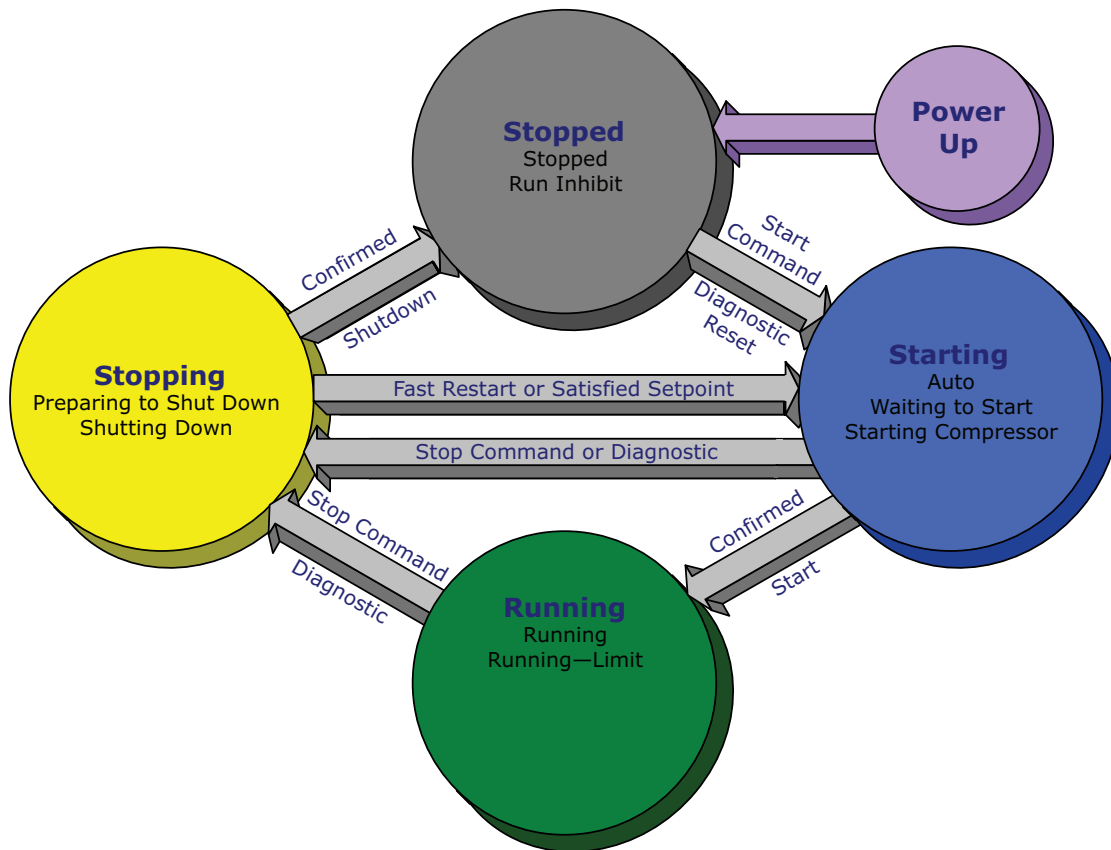

In the following diagrams:

- The time line indicates the upper level operating mode, as it would be viewed in the Tracer AdaptiView.
- The shading color of the cylinder indicates the software state.

- The first line of text in the circles is the visible top level operating modes that can be displayed in Tracer® AdaptiView™.
- The shading of each software state circle corresponds to the shading on the time lines that show the chiller's state.

There are five generic states that the software can be in:

- Power Up
- Stopped
- Starting
- Running
- Stopping

- Text in parentheses indicates sub-mode text as viewed in the Tracer AdaptiView.
- Text above the time line cylinder is used to illustrate inputs to the Symbio™ 800. This may include user input to the Tracer AdaptiView touch screen, control inputs from sensors, or control inputs from a generic BAS.

Start-Up and Shutdown

- Boxes indicate control actions such as turning on relays, or moving the inlet guide vanes.
- Smaller cylinders under the main cylinder indicate diagnostic checks.
- Text outside a box or cylinder indicates time-based functions.
- Solid double arrows indicate fixed timers.
- Dashed double arrows indicate variable timers.

Start-Up Sequence of Operation—Wye-delta

Logic circuits within the various modules will determine the starting, running, and stopping operation of the chiller. When operation of the chiller is required, the chiller mode is set at “Auto.” Using customer-supplied power, the chilled water pump relay is energized and chilled water flow must be verified within 4 minutes and 15 seconds, at the same time the oil vent line valve is opened. The controller

decides to start the chiller based on the differential to start setpoint. With the differential to start criteria met, the controller then energizes condenser water pump relay with customer-supplied power (refer to the following figure).

Based on the Restart Inhibit function and the Differential to Start setpoint, the oil and refrigerant pump is energized, and the oil vent line valve is closed to the minimum position. The oil pressure must be at least 12 psid (82.7 kPaD) for 60 continuous seconds and condenser water flow verified within 4 minutes and 15 seconds for the compressor start sequence to be initiated. After the compressor starts, the oil vent line valve begins to open; it can take between 15 and 30 minutes to fully open depending on the chiller running conditions.

The compressor motor starts in the “Wye” configuration and then, after the compressor motor has accelerated and the maximum phase current has dropped below 85 percent of the chiller nameplate RLA for 1.5 seconds, the starter transitions to the “Delta” configuration.

Figure 54. Sequence of operation: power up to starting

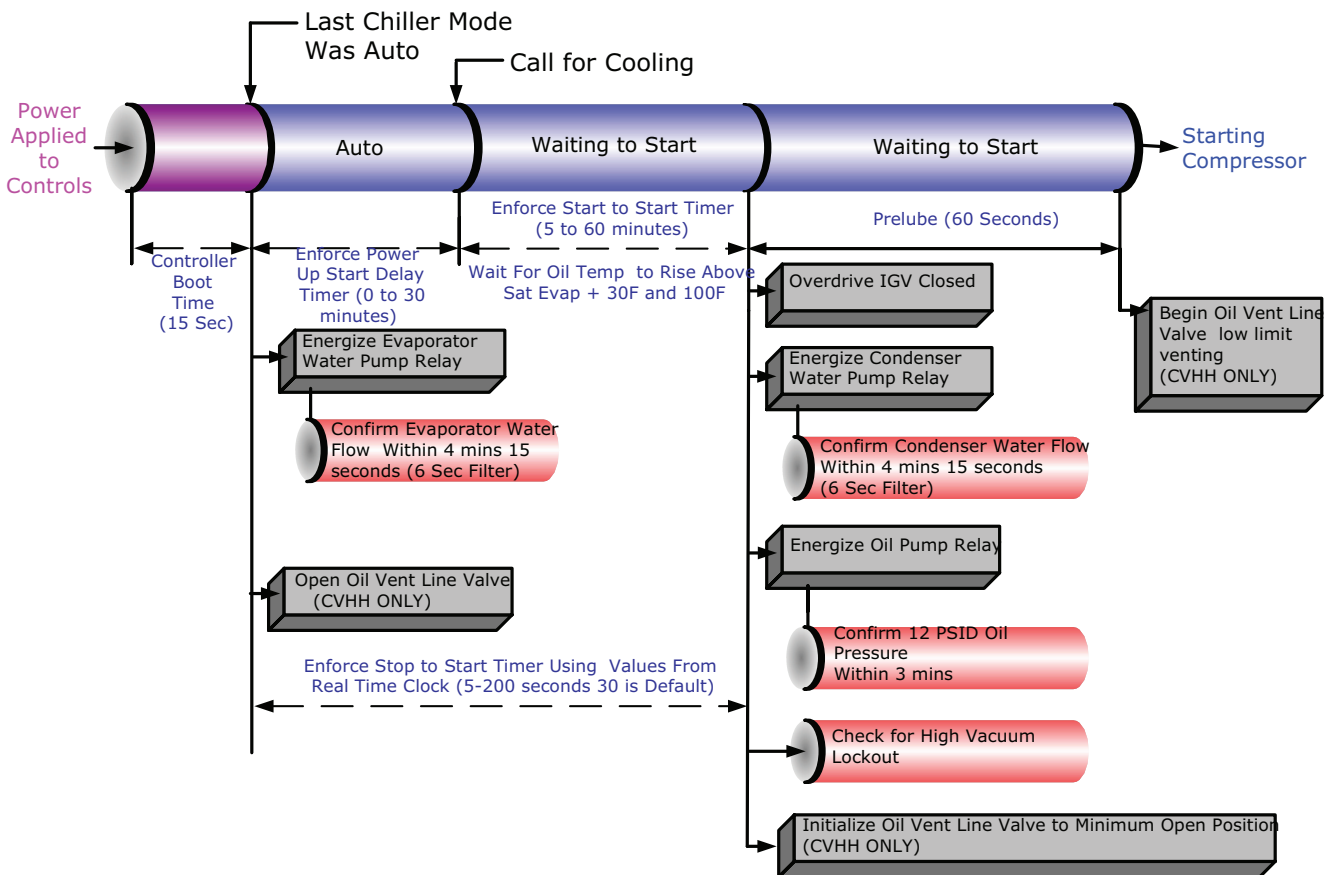

Now that the compressor motor is running in the “Delta” configuration, the inlet guide vanes will modulate, opening and closing to the chiller load variation by operation of the stepper vane motor actuator to satisfy chilled water setpoint. The chiller continues to run in its appropriate mode of operation: Normal, Softload, Limit Mode, and so

on (refer to the following figure [running]). If the oil tank temperature rises above the oil cooler setpoint while the compressor is running, the oil cooler solenoid valve shall be energized to cool the oil.

If the chilled water temperature drops below the chilled water setpoint by an amount set as the differential to stop

setpoint, a normal chiller stop sequence is initiated as follows:

1. The inlet guide vanes are driven closed (up to 50 seconds).
2. After the inlet guide vanes are closed, the stop relay and the condenser water pump relays open to turn off. The oil and refrigerant pump motor will continue to run for 3 minutes post-lube while the compressor coasts to

a stop. The oil vent line valve will then open. The chilled water pump will continue to run while the Symbio™ 800 monitors leaving chilled water temperature, preparing for the next compressor motor start based on the differential to start setpoint.

The following figure (satisfied setpoint) illustrates this sequence.

Figure 55. Sequence of operation: running

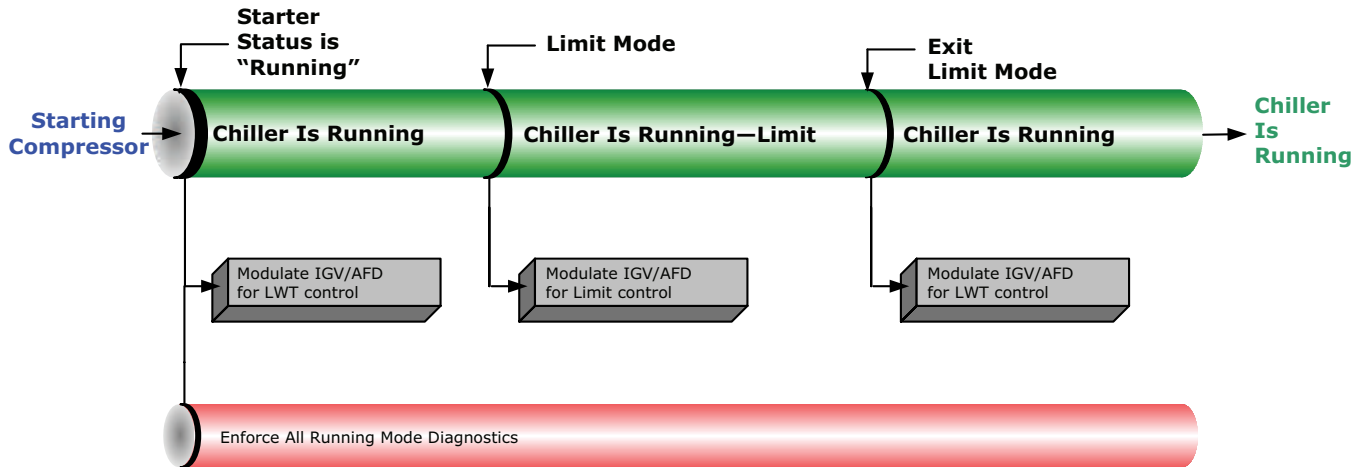

Note: If the Oil Tank Temperature rises above the Oil Cooler Control Setpoint while the compressor is running, the Oil Cooler Solenoid Valve shall be energized to cool the unit.

Figure 56. Sequence of operation: satisfied setpoint

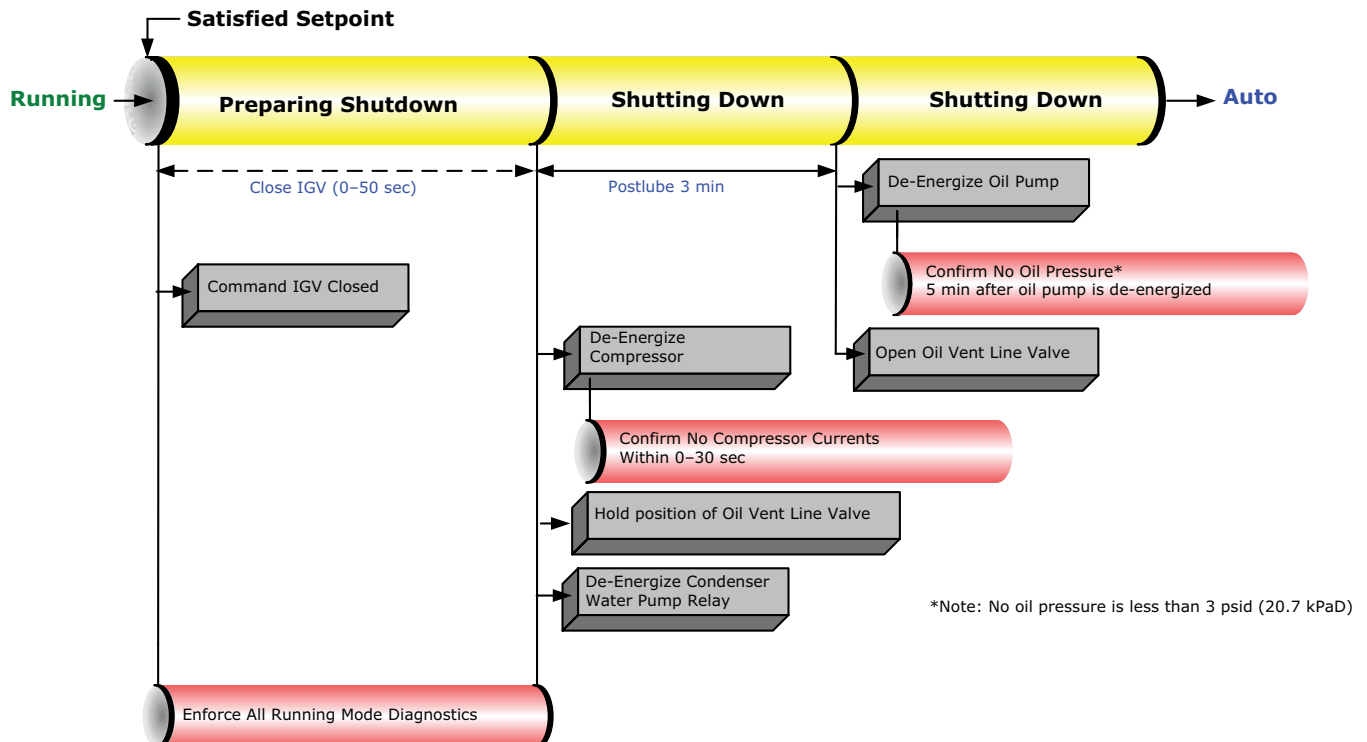

Start-Up and Shutdown

If the STOP key is pressed on the operator interface, the chiller will follow the same stop sequence as described earlier except the chilled water pump relay will also open and stop the chilled water pump after the chilled water pump delay timer has timed out after compressor shutdown (refer to the following figure [normal shutdown to stopped

and run inhibit]).

If the immediate stop is initiated, a panic stop occurs which follows the same stop sequence as pressing the STOP key once, except the inlet guide vanes are not sequence-closed and the compressor motor is immediately turned off.

Figure 57. Sequence of operation: normal shutdown to stopped and run inhibit

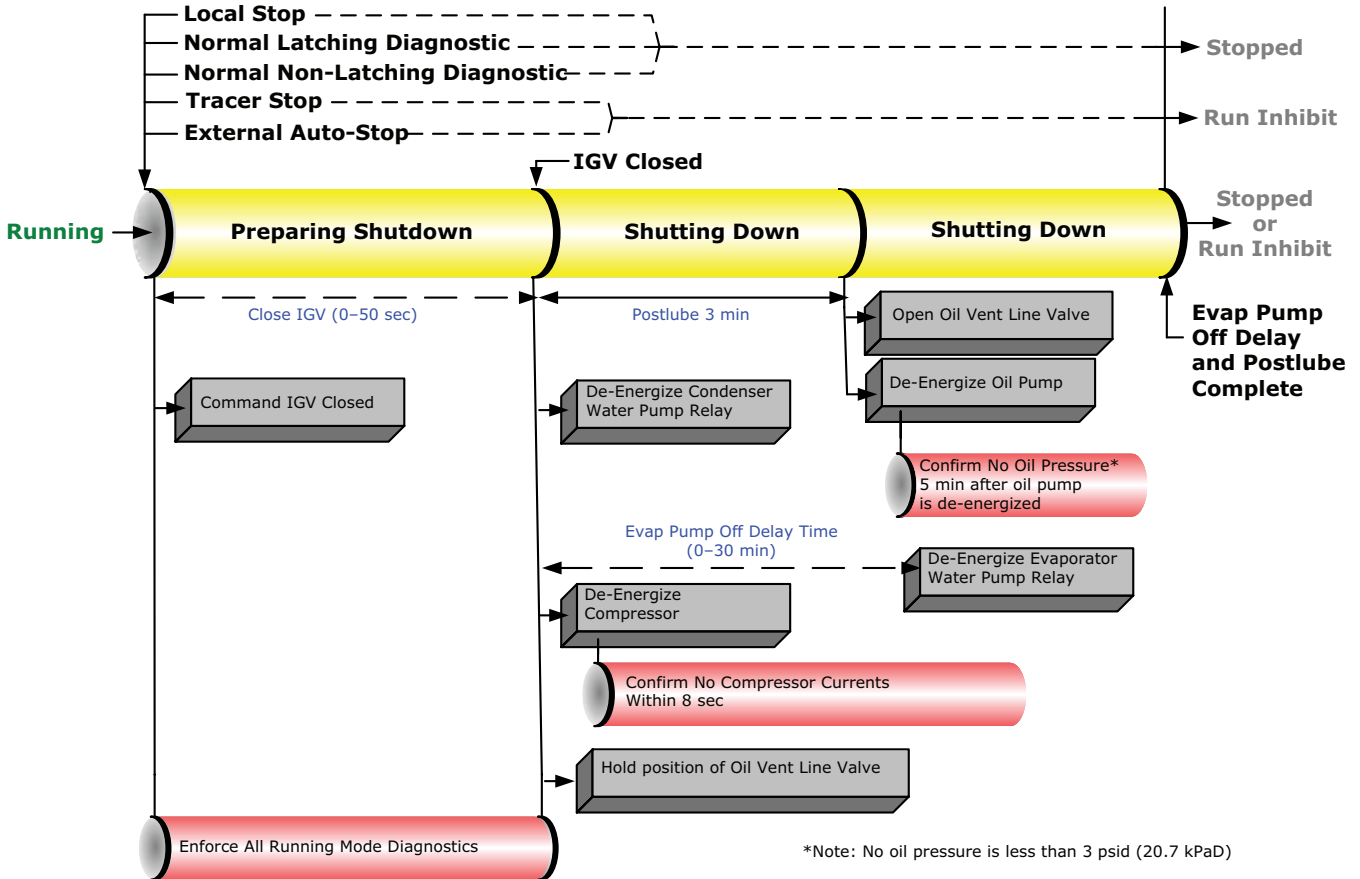

Power Up

“Software Operation Overview Diagram,” p. 85 includes an illustration of Tracer® Symbio 800 during a power up of the controller. This process takes up to 15 seconds, depending on the number of installed options.

Ice Building Control

The control panel provides a service level Enable or Disable menu entry for the Ice Building feature when the Ice Building option is installed. Building can be entered from Front Panel or, if hardware is specified, the control panel will accept either an isolated contact closure 1K9 Terminals J2-1 and J2-2 (Ground) or a remote-communicated input (BAS) to initiate the Ice Building mode where the unit runs fully loaded at all times. Ice Building will be terminated either by opening the contact or based on entering evaporator fluid temperature. The control panel will not permit the Ice Building mode to be entered again

until the unit is switched to the non-ice building mode and back into the ice building mode. It is not acceptable to reset the chilled water setpoint low to achieve a fully loaded compressor. When entering Ice Building, the compressor will be loaded at its maximum rate and when leaving Ice Building, the compressor will be unloaded at its maximum rate. While loading and unloading the compressor, all surge detection will be ignored. While in the ice building mode, demand limit setpoints less than the maximum will be ignored. Ice Building can be terminated by one of the following means:

- Front panel disable
- Opening the external ice contacts/remote-communicated input (BAS)
- Satisfying an evaporator entering fluid temperature setpoint (default is 27°F [-2.8°C])
- Surging for seven minutes at full open inlet guide vanes (IGV)

Figure 58. Sequence of operation: ice building: running to ice making

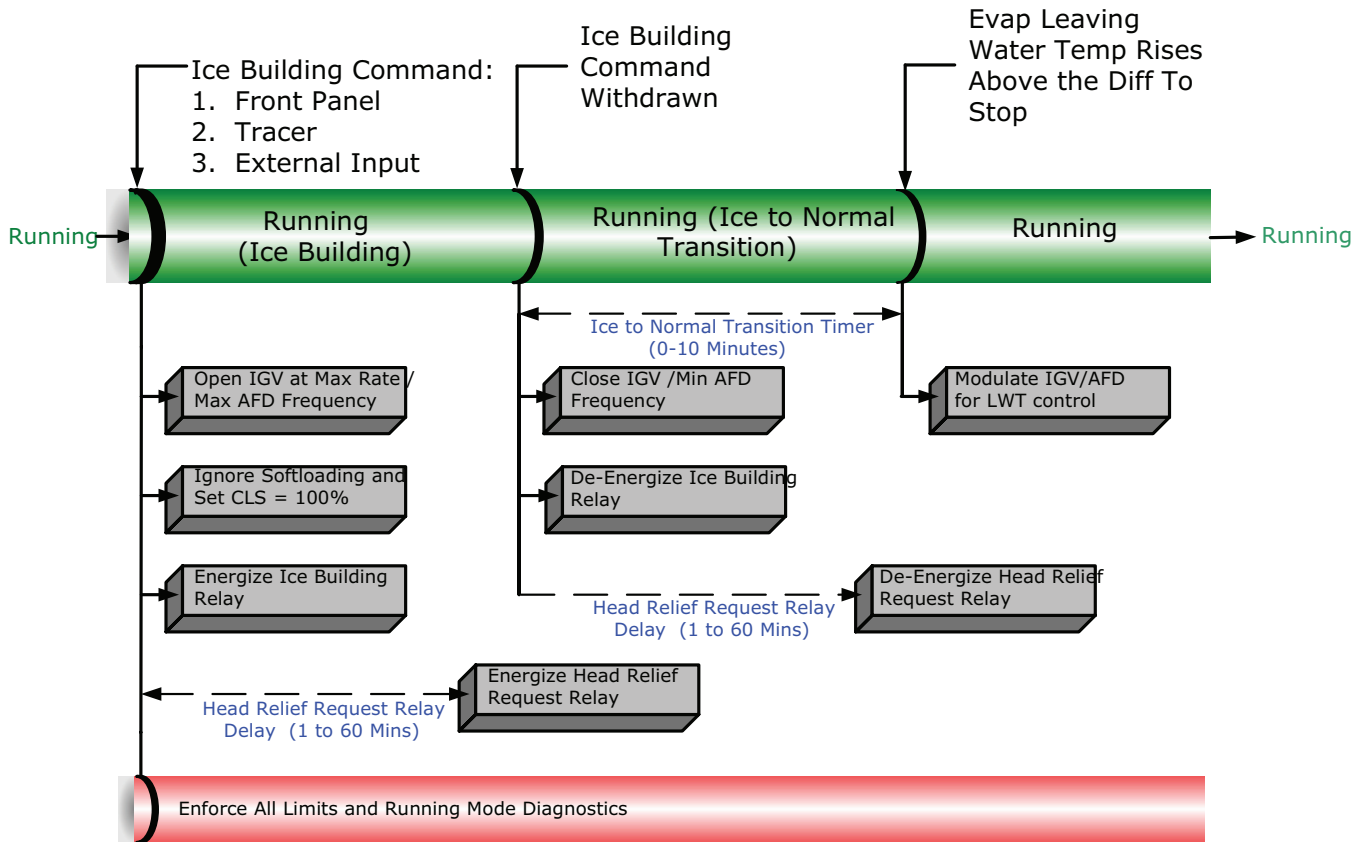
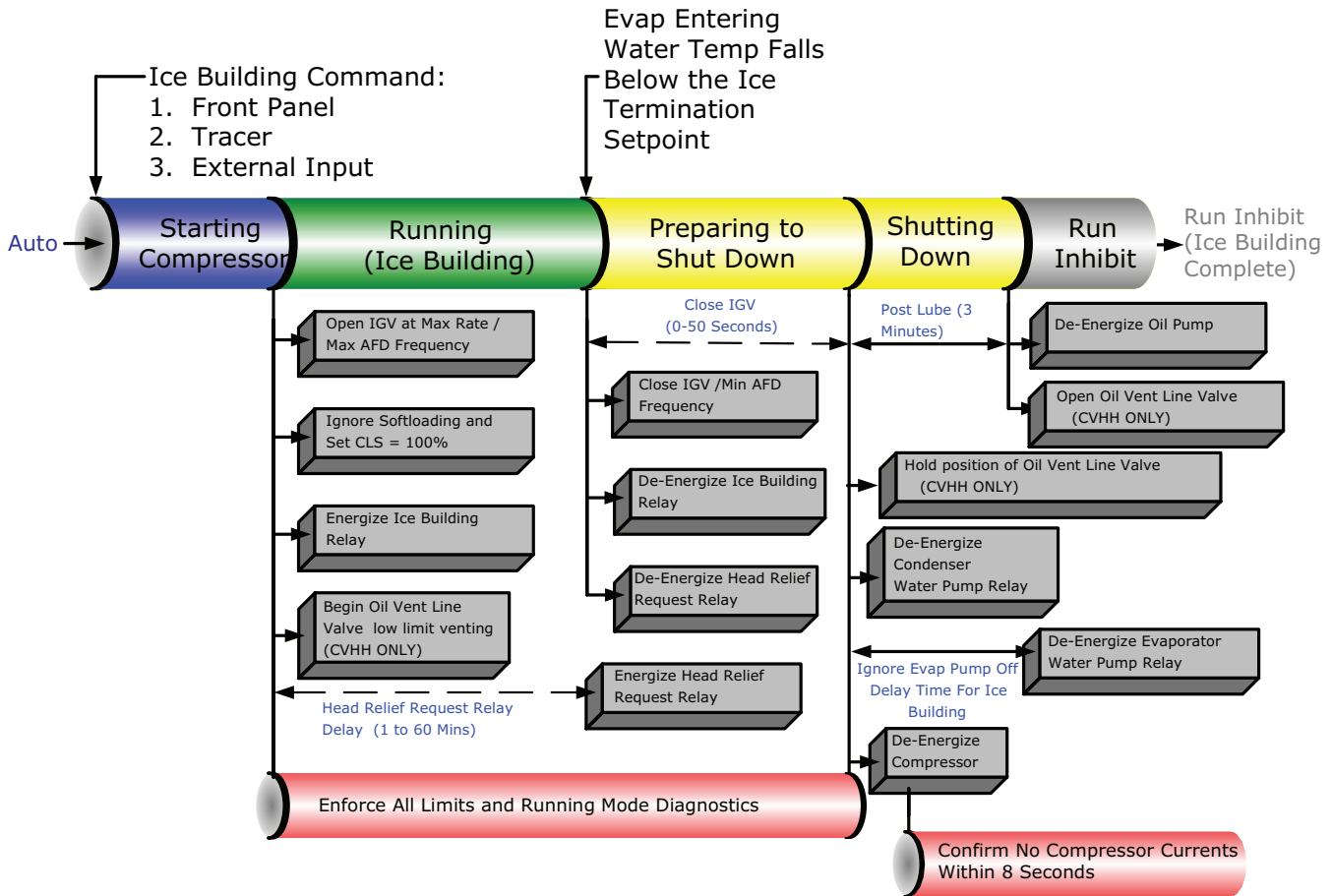

Figure 59. Sequence of operation: ice building: stopped to ice to ice building complete



Free Cooling Cycle

Based on the principle that refrigerant migrates to the coldest area in the system, the free cooling option adapts the basic chiller to function as a simple heat exchanger. However, it does not provide control of the leaving chilled water temperature.

If condenser water is available at a temperature lower than the required leaving chilled water temperature, the operator interface must remain in **AUTO** and the operator starts the free cooling cycle by enabling the Free Cooling mode in the Tracer® AdaptiView™ Feature Settings group of the operator interface, or by means of a BAS request. The following components must be factory- or field-installed to equip the unit for free cooling operation:

- a refrigerant gas line, and electrically-actuated shutoff valve, between the evaporator and condenser, and
- a valved liquid return line, and electrically-actuated shutoff valve, between the condenser sump and the evaporator.

When the chiller is changed over to the free cooling mode, the compressor will shutdown if running and the shutoff valves in the liquid and gas lines open; unit control logic prevents the compressor from energizing during free cooling. Since the temperature and pressure of the

refrigerant in the evaporator are higher than in the condenser (i.e., because of the difference in water temperature), the refrigerant in the evaporator vaporizes and travels to the condenser, cooling tower water causes the refrigerant to condense on the condenser tubes, and flow (again, by gravity) back to the evaporator.

This compulsory refrigerant cycle is sustained as long as a temperature differential exists between condenser and evaporator water. The actual cooling capacity provided by the free cooling cycle is determined by the difference between these temperatures which, in turn, determines the rate of refrigerant flow between the evaporator and condenser shells.

If the system load exceeds the available free cooling capacity, the operator must manually initiate changeover to the mechanical cooling mode by disabling the free cooling mode of operation. The gas and liquid line valves then close and compressor operation begins (refer to the figure in “Start-Up Sequence of Operation—Wye-delta,” p. 86 [power up to starting], beginning at Auto mode). Refrigerant gas is drawn out of the evaporator by the compressor, where it is then compressed and discharged to the condenser.

Hot Water Control

Occasionally, CenTraVac™ chillers are selected to provide heating as a primary mission. With hot water temperature control, the chiller can be used as a heating source or cooling source. This feature provides greater application flexibility. In this case, the operator selects a hot water temperature and the chiller capacity is modulated to maintain the hot water setpoint. Heating is the primary mission and cooling is a waste product or is a secondary mission. This type of operation requires an endless source of evaporator load (heat), such as well or lake water. The chiller has only one condenser.

Note: *Hot Water Temperature Control mode does NOT convert the chiller to a heat pump. Heat pump refers to the capability to change from a cooling-driven application to a heating-driven application by changing the refrigerant path on the chiller. This is impractical for centrifugal chillers as it would be much easier to switch over the water side.*

This is NOT heat recovery. Although this feature could be used to recover heat in some form, a heat recovery unit has a second heat exchanger on the condenser side.

The Tracer® Symbio™ 800 provides the Hot Water Temperature Control mode as standard. The leaving condenser water temperature is controlled to a hot water setpoint between 80°F and 140°F (26.7°C and 60.0°C). The leaving evaporator water temperature is left to drift to satisfy the heating load of the condenser. In this application, the evaporator is normally piped into a lake, well, or other source of constant temperature water for the purpose of extracting heat. In Hot Water Temperature Control mode, all the limit modes and diagnostics operate as in normal cooling with one exception: the leaving condenser water temperature sensor is an MMR diagnostic when in Hot Water Temperature Control mode. (It is an informational warning in the Normal Cooling mode.)

In the Hot Water Temperature Control mode, the differential-to-start and differential-to-stop setpoints are used with respect to the hot water setpoint instead of with the chilled water setpoint. The control panel provides a separate entry at the Tracer AdaptiView™ to set the hot water setpoint; Tracer® AdaptiView™ is also able to set the hot water setpoint. In the Hot Water mode, the external chilled water setpoint is the external hot water setpoint; that is, a single analog input is shared at the 1K6-J2-5 to 6 (ground).

An external binary input to select external Hot Water Control mode is on the EXOP OPTIONAL module 1K8 terminals J2-3 to J2-4 (ground). Tracer Symbio 800 also has a binary input to select chilled water control or hot water temperature control. There is no additional leaving hot water temperature cutout; the HPC and condenser limit provide for high temperature and pressure protection.

In Hot Water Temperature Control, the softloading pulldown rate limit operates as a softloading pullup rate limit. The setpoint for setting the temperature rate limit is the same setpoint for normal cooling as it is for hot water temperature control.

The factory set PID tuning values for the leaving water temperature control are the same settings for both normal cooling and hot water temperature control.

Control Panel Devices and Unit-Mounted Devices

Unit Control Panel

Safety and operating controls are housed in the unit control panel, the starter panel, and the purge control panel. The control panel operator interface is called Tracer® AdaptiView™ and is located on an adjustable arm connected to the base of the control panel. For more information about operating Tracer® AdaptiView™, refer to *Tracer® AdaptiView™ Display for Water-cooled CenTraVac™ Chillers with Symbio™ Operations Guide* (CTV-SVU004*-EN). For more information on the Symbio™ 800 controller, refer to *Symbio™ 800 Controller Installation, Operation, and Maintenance* (BAS-SVX080*-EN).

The control panel houses several other controls modules called panel-mounted Low Level Intelligent Devices (LLIDs), power supply, terminal block, fuse, circuit breakers, and transformer. The inter-processor communication (IPC) bus allows the communications between LLIDs and the controller. Unit-mounted devices are called frame-mounted LLIDs and can be temperature sensors or pressure transducers. These and other functional switches provide analog and binary inputs to the control system.

User-defined Language Support

Tracer® AdaptiView™ is capable of displaying English text or any of 26 other languages (27 total languages). Switching languages is simply accomplished from a Language Settings menu. The following languages are available:

- Arabic (Gulf Regions)
- Chinese—China
- Chinese—Taiwan
- Czech
- Dutch
- English
- French
- French (Canada)
- German
- Greek
- Hebrew
- Hungarian
- Indonesian
- Italian
- Japanese

Start-Up and Shutdown

- Korean
- Norwegian
- Polish
- Portuguese (Portugal)
- Portuguese (Brazil)
- Russian
- Romanian
- Spanish (Europe)
- Spanish (Latin America)
- Swedish
- Thai
- Turkish

Unit Start-Up and Shutdown Procedures

⚠ WARNING

Live Electrical Components!

Failure to follow all electrical safety precautions when exposed to live electrical components could result in death or serious injury.

When it is necessary to work with live electrical components, have a qualified licensed electrician or other individual who has been properly trained in handling live electrical components perform these tasks.

⚠ WARNING

Toxic Hazards!

A significant release of refrigerant into a confined space due to a rupture disk failure could displace available oxygen to breathe and cause possible asphyxiation. Failure to follow instructions below could result in death or serious injury.

Should a rupture disk fail, evacuate the area immediately and contact the appropriate rescue or response authority.

While the unit is off, do not allow the chiller to exceed 130°F (54.4°C). Failure to prevent high chiller temperature will cause the inside pressure to rise:

- Do not run evaporator water pump longer than 30 minutes after the chiller is shut down.
- Ensure that the evaporator is isolated from the hot water loop before changeover to heating mode.

The rupture disk is designed to relieve and discharge the refrigerant from the unit if the pressure in the evaporator exceeds 50 psig (344.7 kPaG).



Note: Graphic labels (shown above) are used for CE application only.

Important:

- Before servicing, disconnect all power sources and allow at least 30 minutes for capacitors to discharge.
- All electrical enclosures—unit or remote—are IP2X.

Daily Unit Start-Up

1. Verify the chilled water pump and condenser water pump starter are in ON or AUTO.
2. Verify the cooling tower is in ON or AUTO.
3. Check the oil tank oil level; the level must be visible in or above the lower sight glass. Also, check the oil tank temperature; normal oil tank temperature before start-up is 128°F to 133°F (53.3°C to 56.1°C).
4. Check the chilled water setpoint and readjust it, if necessary, in the Chiller Settings menu.
5. If necessary, readjust the demand limit setpoint in the Chiller Setpoints menu.
6. Press AUTO.

The control panel also checks compressor motor winding temperature and a start is initiated after a minimum restart inhibit time if the winding temperature is less than 265°F (129.4°C). The chilled water pump relay is energized and evaporator water flow is proven. Next, the control panel checks the leaving evaporator water temperature and compares it to the chilled water setpoint. If the difference between these values is less than the start differential setpoint, cooling is not needed.

If the control panel determines that the difference between the evaporator leaving water temperature and chilled water setpoint exceeds the start differential setpoint, the unit enters the initiate Start Mode and the oil and refrigerant pump and the condenser water pump are started. If flow is not initially established within 4 minutes 15 seconds of the

condenser pump relay energization, an automatically resetting diagnostic “Condenser Water Flow Overdue” shall be generated, which terminates the prestart mode and de-energizes the condenser water pump relay. This diagnostic is automatically reset if flow is established at any later time.

Note: *This diagnostic does NOT automatically reset if Tracer® Symbio™ 800 is in control of the condenser pump through its condenser pump relay, since it is commanded off at the time of the diagnostic. It may reset and allow normal chiller operation if the pump was controlled from some external source.*

If the compressor motor starts and accelerates successfully, Running appears on the display. If the purge is set to AUTO, the purge will start running and will run as long as the chiller is running.

Note: *If a manual reset diagnostic condition is detected during start-up, unit operation will be locked out and a manual reset is required before the start-up sequence can begin again. If the fault condition has not cleared, the control panel will not permit restart.*

When the cooling requirement is satisfied, the control panel originates a Shutting down signal. The inlet guide vanes are driven closed for 50 seconds, the compressor stops, and the unit enters a 3-minute post-lube period. The evaporator pump may continue to run for the amount of time set using Tracer® AdaptiView™.

After the post-lube cycle is done, the unit returns to auto mode.

Seasonal Unit Start-Up

1. Close all drain valves and reinstall the drain plugs in the evaporator and condenser headers.
2. Service the auxiliary equipment according to the start-up and maintenance instructions provided by the respective equipment manufacturers.
3. Fill and vent the cooling tower, if used, as well as the condenser and piping. At this point, all air must be removed from the system (including each pass). Then, close the vents in the condenser waterboxes.
4. Open all of the valves in the evaporator chilled water circuit.
5. If the evaporator was previously drained, fill and vent the evaporator and chilled water circuit. After all air is removed from the system (including each pass), close the vent valves in the evaporator waterboxes.
6. Lubricate the external vane control linkage as needed.
7. Check the adjustment and operation of each safety and operating control.
8. Close all disconnect switches.
9. Perform instructions listed in “Daily Unit Start-Up,” p. 92.

Daily Unit Shutdown

Note: *Also refer to the figure (satisfied setpoint) in “Start-Up Sequence of Operation—Wye-delta,” p. 86.*

1. Press STOP.
2. After compressor and water pumps shutdown, the operator may turn Pump Contactors to OFF or open pump disconnects.

Seasonal Unit Shutdown

Important: *Control power disconnect switch must remain closed to allow oil sump heater operation. Failure to do this will allow refrigerant to condense in the oil pump.*

1. Open all disconnect switches except the control power disconnect switch.
2. Drain the condenser piping and cooling tower, if used. Rinse with clean water.
3. Remove the drain and vent plugs from the condenser headers to drain the condenser. Air-dry bundle of residual water.
4. Once the unit is secured for the season, the maintenance procedures described in “Normal Operation,” p. 103 (tables for recommended maintenance of standard and optional features) should be performed by qualified Trane service technicians.

Note: *During extended shutdown periods, be sure to operate the purge unit for a two-hour period every two weeks. This will prevent the accumulation of air and non-condensables in the machine. To start the purge, change the purge mode to ON in the unit control “Settings Purge” menu. Remember to turn the purge mode to “Adaptive” after the two-hour run time.*

EarthWise Purge

Sequence of Operations

A Symbio™ 800 controller that is configured to control a purge system uses the operational sequences described in this section.

Purge Operating Modes

Purge operating mode options are as follows:

- **Stop.** The purge condensing unit does not run in this mode.
- **On.** The purge condensing unit runs continuously in this mode, regardless of the chiller’s operational status.
- **Auto.** The purge condensing unit runs in this mode if the main compressor of the chiller is operating.
- **Adaptive.** The purge condensing unit operation depends on past purge activity.



Start-Up and Shutdown

Adaptive Mode

The objectives of operating the unit in the Adaptive mode are to:

- Enable purge system operation.
- Enable the refrigeration circuit to effectively accumulate non-condensables whether or not the chiller is running.
- Provide information to an operator regarding whether leakage is on the high-pressure or low-pressure side of the chiller.
- Decrease energy usage by running the purge refrigeration circuit only when needed to remove non-condensables, rather than running it continuously.

The Adaptive mode requires historical operating data so that the controller can make optimal decisions regarding how to run the purge refrigeration circuit in the future. On initial start-up of a chiller that is in Adaptive mode, the purge refrigeration circuit runs continuously for 168 hours (7 days). The chiller compressor may or may not be running during this period.

Following the initial data collection period, the Adaptive mode customizes the purge refrigeration circuit operation during two distinct chiller operating conditions:

- Chiller compressor On
- Chiller compressor Off

Adaptive Mode Process—Chiller Compressor On

The following figure illustrates the process described in this subsection.

When the chiller compressor starts, the purge refrigeration circuit starts. The purge refrigeration circuit continues to run until 60 consecutive minutes of running occur without any pump-out of non-condensables. The Pumpout Time is the greater of the following two values that the controller has been tracking:

- The pump-out time with the chiller On, over the last 24 hours
- The average daily pump-out time with the chiller On, over the last 7 days

Figure 60. Adaptive chiller ON flow chart

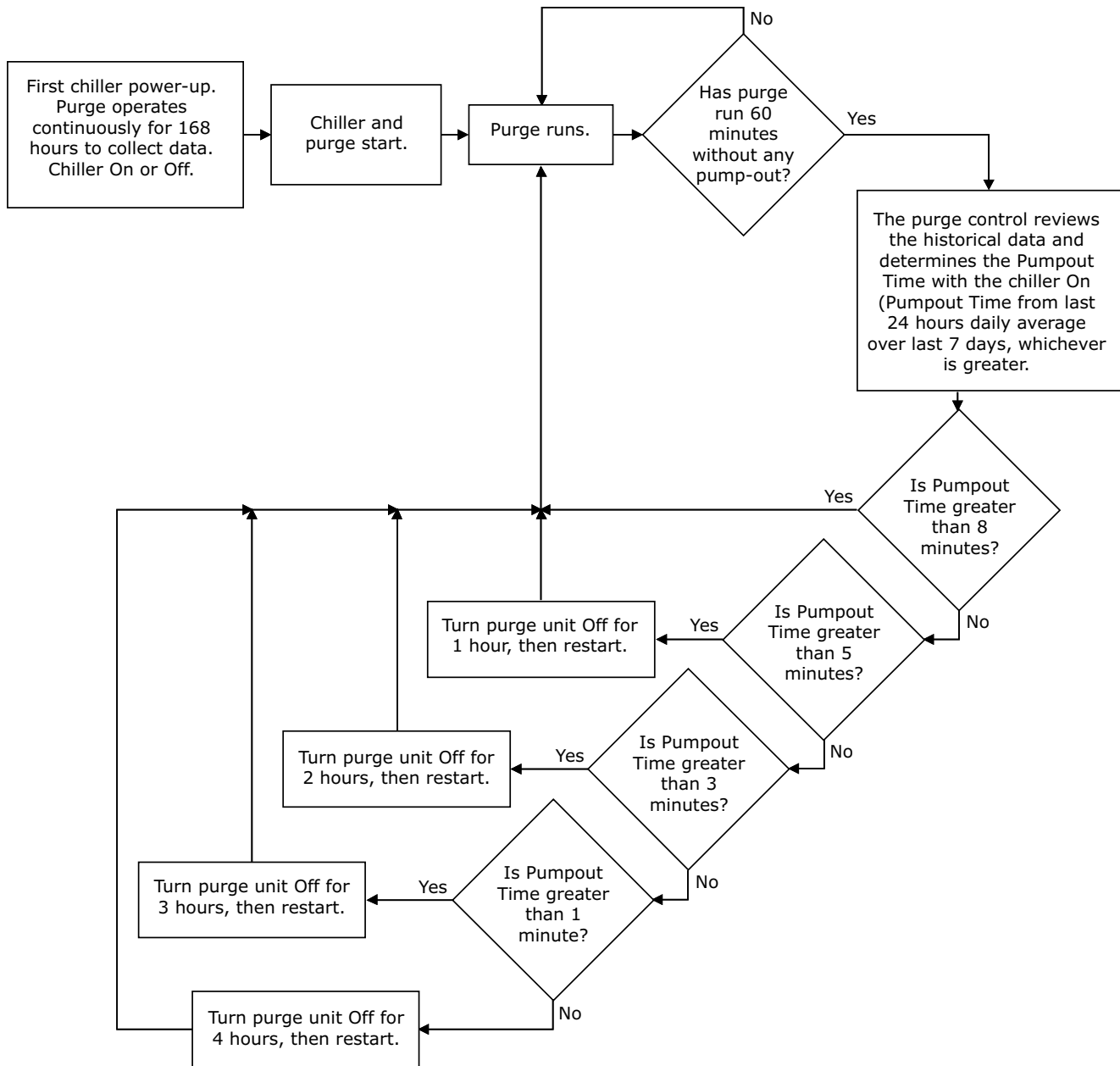

The purge then shuts down for a corresponding period of time, as shown in the following table:

Pumpout Time with chiller On (over the last 24 hours or daily average over the last 7 days, whichever is greater)	Purge Off cycle duration
Pumpout Time ≤ 1 minute	4 hours
1 minute < Pumpout Time ≤ 3 minutes	3 hours
3 minutes < Pumpout Time ≤ 5 minutes	2 hours
5 minutes < Pumpout Time ≤ 8 minutes	1 hour
Pumpout Time > 8 minutes	No Off cycle

During the purge refrigeration circuit Off cycle, the time remaining is displayed as Time Until Next Purge Run in the Log Sheet that you can view from the Tracer[®] AdaptiView™ display.

If the compressor is turned Off during the purge refrigeration circuit Off cycle, the purge transfers to Adaptive Mode Procedure—Chiller Compressor Off. “Adaptive Mode Procedure—Chiller Compressor Off,” p. 95 includes an illustration of this process.

Adaptive Mode Procedure—Chiller Compressor Off

Refer to the following figure for an illustration of the process described in this subsection.

Start-Up and Shutdown

If the chiller compressor is turned Off, the purge refrigeration circuit Off cycle is determined by the purge control. The purge Off-cycle duration is determined by the pump-out time, which is the greater of the following two values:

- Daily Pumpout—24 hours (the pump-out time over the last 24 hours whether the chiller is On or Off)

- Average Daily Pumpout—7 days (the pump-out time with the chiller On over the last 7 days)

Note: These two values can be seen on the Tracer® AdaptiView™ display.

Figure 61. Adaptive chiller OFF flow chart

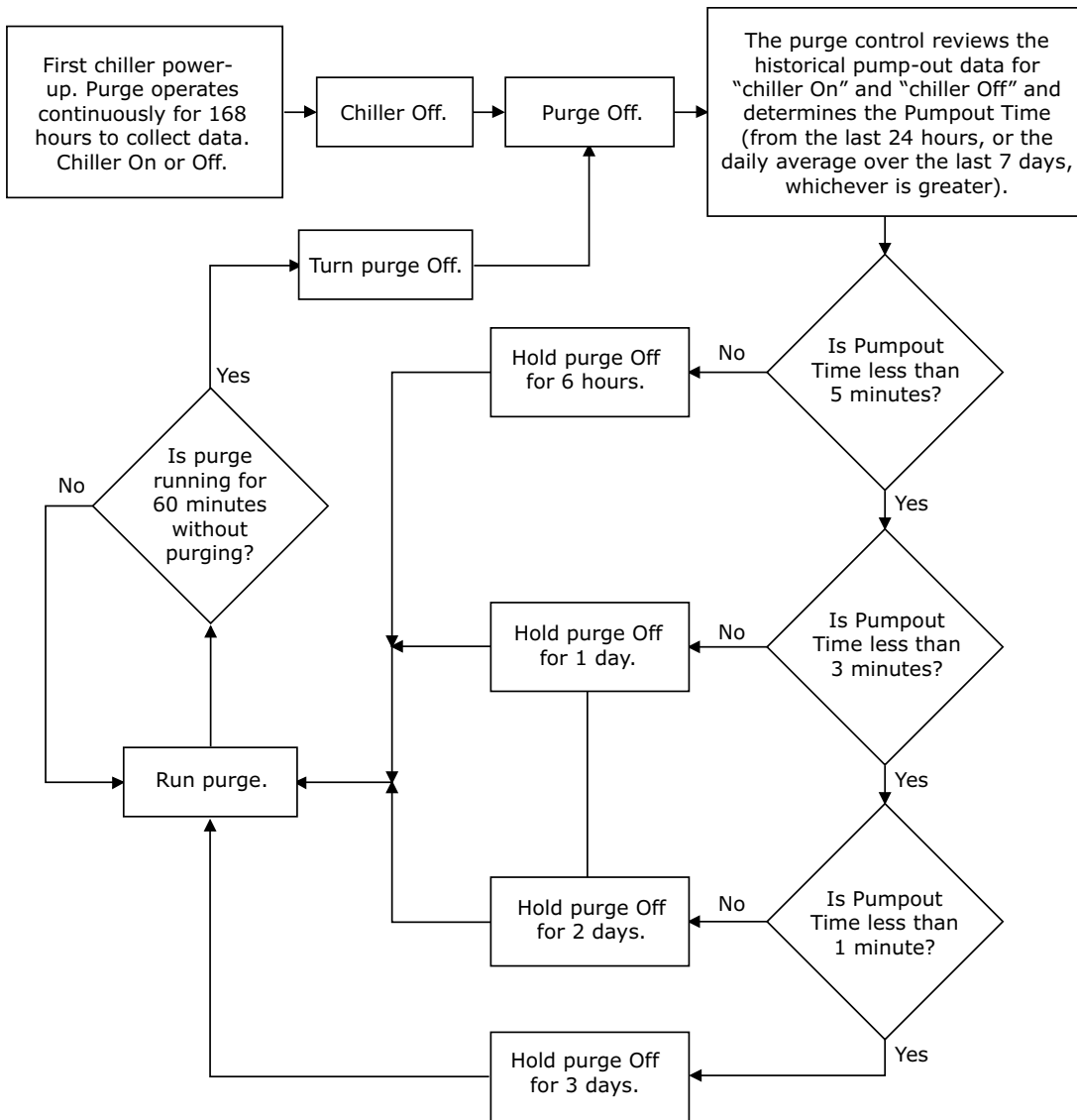

The purge will be shutdown for a corresponding period of time, as shown in the following table:

Pumpout Time with chiller On or Off (over the last 24 hours or daily average over the last 7 days, whichever is greater)	Purge Off cycle duration
Pumpout Time ≤ 1 minute	3 days
1 minute < Pumpout Time ≤ 3 minutes	2 days
3 minutes < Pumpout Time ≤ 5 minutes	1 day
Pumpout Time > 5 minutes	6 hours

During the purge refrigeration circuit Off cycle, the time remaining is displayed as the Time Until Next Purge Run in the purge report of the Tracer® AdaptiView™ display.

If the controls determine it is necessary to run the purge while the chiller compressor is Off, the purge will be started and run until 60 consecutive minutes have passed without any pump-out of non-condensables.

If the chiller compressor starts before the purge Off cycle has elapsed, the purge starts and transfers to Adaptive Mode Procedure – Chiller Compressor On. [“Adaptive Mode](#)

Process—Chiller Compressor On,” p. 94 includes an illustration of this process.

Submodes

You can view submodes from the Purge Settings screen. The available purge submodes are:

- **Refrigeration Circuit On.** Appears if the purge condensing unit/compressor is operating.
- **Refrigeration Circuit Idle.** Appears if the purge condensing unit/compressor is not operating.
- **Pumping Out.** Appears if the purge refrigeration circuit is On and pump-out has been initiated by the purge unit controls.
- **Exhaust Circuit Check.** Appears if a pump-out has been initiated by an operator.
- **Pumpout Inhibited.** Appears if the purge refrigeration circuit is On but pump-out has been inhibited by a low condenser saturation temperature.
- **Daily Pumpout Limit Disabled.** Appears if the purge refrigeration circuit is On but the daily pump-out limit has been disabled.
- **Regenerating.** Appears if the purge carbon system is in its regeneration mode. Pump-out is not allowed in this submode.
- **Alarm—Check Diagnostics.** Appears if a new diagnostic occurs.

- **Purge Diag Shutdown.** Appears if the purge system has shutdown in response to a latching diagnostic.
- **Regen Disabled.** Appears if carbon regeneration is not allowed.

Typical Purge Refrigeration Circuit Operating Cycle

The purge condensing-unit compressor suction temperature varies with the amount of non-condensables collected in the purge tank. If the amount of non-condensables collected in the purge tank limits the available condensing surface in the tank, the condensing-unit compressor suction temperature begins to fall.

The purge controller initiates a pump-out cycle when the suction temperature reaches the pump-out initiate value that is calculated within the purge control. During the pump-out cycle, the small pump-out compressor pulls any non-condensables from the purge tank and discharges them through the carbon tank. As the non-condensables are removed from the purge tank, the condensing-unit compressor suction temperature increases. The purge controller monitors the compressor suction temperature and cycles or stops the pump-out, depending on the temperature that is present.

The 1/4 hp air-cooled condensing unit of the refrigeration system operates effectively when it is in the operating range shown in the following figure.

Figure 62. Purge operating limits

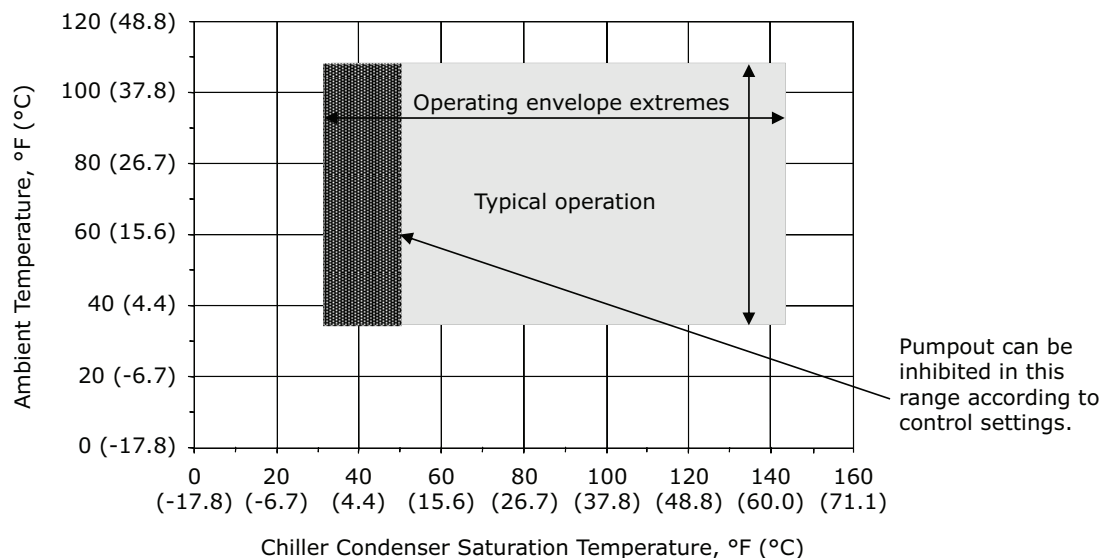

Air Removal

If no air is in the purge tank, the refrigerant returning to the purge condensing unit compressor suction has a high *superheat* (heat added past the point of evaporation), because of the heat removed from the condensing chiller refrigerant vapor in the purge tank. As air accumulates in the purge tank, it displaces the chiller refrigerant vapor and decreases the amount of coil surface that is exposed to the

vapor. Less heat is removed from the vapor, and the available superheat at the purge condensing unit compressor suction consequently falls. When the purge refrigerant compressor suction temperature falls far enough to reach the pump-out initiate value, the purge control activates the solenoids and the pump-out compressor to remove the accumulated air.



Start-Up and Shutdown

As air is removed from the purge tank, the inside coil is once again exposed to chiller refrigerant vapor. As more chiller refrigerant vapor condenses on the coil, more heat is removed from the vapor, and the purge refrigerant compressor suction temperature rises. The purge control cycles or stops the pump-out process in response to the compressor suction temperature.

Pump-out Operating Sequence

As the purge control system detects the presence of non-condensables in the purge tank, it initiates a pump-out cycle. The pump-out solenoid valve, the exhaust solenoid valve, and the pump-out compressor cycle On and Off as needed to remove the non-condensables.

Non-condensable Pump-out Algorithm

The controller uses the non-condensable pump-out algorithm to determine when to initiate, control, and terminate a pump-out cycle to remove air from the purge tank. The purge refrigerant compressor suction temperature sensor serves as the feedback to this control algorithm. The compressor suction temperature pump-out initiate and pump-out terminate values are calculated by the purge control and are a function of the purge liquid temperature.

The refrigerant used in the purge refrigeration circuit, R-513A, is metered into the purge tank coil by a constant-pressure regulating expansion valve. The valve automatically controls the purge suction pressure at a constant value of 21.5 psia (148.2 kPaA). Therefore, refrigerant is metered into the coil as a two-phase refrigerant mixture at a constant saturation temperature of approximately -3°F (-19.4°C).

The cold coil creates a low vapor pressure near its outside surface, which draws refrigerant from the chiller condenser into the purge tank and to the coil surface. When the refrigerant gets close enough to the coil surface, it condenses into a liquid. Since liquid refrigerant requires less volume than it does in a gaseous form, additional refrigerant enters the purge tank to fill the void and, in turn, condenses. This mechanism is known as a *thermal siphon*.

As the chiller refrigerant condenses, heat is transferred into the purge coil through the latent heat of condensation. The compressor suction temperature sensor monitors this heat transfer.

Air and other gases carried with the chiller refrigerant vapor do not condense on the coil. Instead, they accumulate in the purge tank, effectively acting to insulate and inhibit the flow of refrigerant to the cold coil surface. The thermal siphon rate is reduced and, consequently, so is the amount of heat transfer. A corresponding reduction occurs in the temperature of the purge refrigerant exiting the coil. The compressor suction temperature sensor monitors this temperature.

When sufficient non-condensables have accumulated in the purge tank to decrease the compressor suction temperature below the pump-out initiate value, a pump-out cycle begins. The cycle is terminated when the compressor

suction temperature sensor increases above the pump-out terminate value. The calculations for the pump-out values are:

Pump-out initiate:

- (°F) = Purge liquid temperature (°F) – 50°F, or 0°F (whichever is higher)
- (°C) = Purge liquid temperature (°C) – 10.0°C, or -17.8°C (whichever is higher)

Pump-out terminate:

- (°F) = Purge liquid temperature (°F) – 40°F, or 5°F (whichever is higher)
- (°C) = Purge liquid temperature (°C) – 4.4°C, or -15.0°C (whichever is higher)

The purge liquid temperature value comes from the chiller's saturated condenser temperature sensor when the chiller is running, or the chiller's saturated evaporator temperature sensor when the chiller is off.

Non-condensable Pump-out Cycle

A non-condensable pump-out cycle may be initiated as described below only if the following two conditions are met:

- a carbon regeneration cycle is NOT in process, and
- the refrigeration circuit is on.

If at any time, except as described above, the purge refrigerant compressor suction temperature drops below the pump-out initiate value, the following sequence is initiated by the controls.

The controller starts the pump-out compressor and opens the exhaust solenoid valve. After 5 seconds, the pump-out solenoid valve opens and pulses at a rate of 20 seconds On and 20 seconds Off. If after two cycles, the purge refrigerant compressor suction temperature has not exceeded the pump-out terminate value, the pump-out solenoid valve stays continuously open. If the pump-out compressor runs for more than 10 consecutive minutes, the controller recalculates the pump-out initiate and pump-out terminate values as described.

The purge controls continue to operate the pump-out solenoid valve and calculate values as described above until the purge refrigerant compressor suction temperature rises above the pump-out terminate value. At this point, the controller will close the pump-out solenoid valve and turn off the pump-out compressor and exhaust solenoid valve.

Note: For purge systems equipped with standard pump-out compressors, operation at low chiller condenser saturation temperatures may result in a system vacuum greater than the pump-out compressor can overcome. If the chiller experiences low condensing temperatures, then the Symbio™ 800 controller can be programmed to inhibit the operation of the purge pump-out compressor.

Carbon Tank and Regeneration Subsystem

The function of the carbon tank is to absorb refrigerant molecules that may be entrained in the discharge of non-condensables. In order to maintain effectiveness, the carbon tank periodically regenerates.

Carbon Regeneration Algorithm

The controller uses the carbon regeneration algorithm to determine when to initiate, control, and terminate a carbon regeneration cycle. The carbon bed temperature sensor serves as the feedback to this algorithm. In addition, the controller uses a pump-out accumulation timer to indicate the remaining carbon capacity in the carbon tank. The carbon capacity is the capacity of the carbon to adsorb refrigerant while maintaining acceptable levels of refrigerant emission through the chiller vent line. A capacity of 100 percent means the carbon bed has the capacity to adsorb refrigerant and maintain acceptable emission levels. A capacity of 0 percent means the carbon bed has inadequate capacity to adsorb refrigerant and still maintain acceptable emission levels.

The main objectives of the carbon regeneration algorithm are to:

- Minimize the amount of refrigerant contained in the carbon by performing a periodic regeneration.
- Regenerate to maintain low emissions levels.
- Minimize the regeneration time.
- Regenerate only when the chiller is at a minimum level of purging activity.
- Allow regeneration to occur with the chiller On or Off. Regeneration is preferable when the chiller is On to ensure low carbon tank pressure, but regeneration is also acceptable when the chiller is Off.

The remaining amount of adsorption capacity within the carbon tank is directly proportional to the number of purge pump-out minutes that have accumulated, and is also a function of the chiller refrigerant type. The purge carbon tank on an R-1233zd-equipped chiller is considered to be fully saturated after the purge has accumulated 350 minutes of pump-out time. Because the relationship between pump-out capacity and pump-out minutes is directly proportional, it can be described by the following equation within the regeneration algorithm:

Remaining carbon capacity% =

$$100 - (\text{pump-out minutes since last regen/pump-out minutes at 100\% capacity}) * 100$$

For example, an R-1233zd-equipped chiller that has accumulated 80 minutes of purge pump-out time since the last carbon tank regeneration would be estimated to have 84 percent carbon tank capacity remaining:

$$100 - (80/350) * 100 = 84\%$$

The purge controls may initiate a carbon tank regeneration cycle when the remaining carbon tank capacity is calculated to be less than 80 percent. However, the

continued stable operation of the chiller is always more important than the regeneration of the carbon tank.

Therefore, the following rules apply:

1. If the Daily Pump-out Limit is disabled, a regeneration cycle may not be initiated, regardless of the value of the remaining carbon capacity.
Also, if the Daily Pump-out Limit is disabled during a regeneration cycle, the regeneration cycle must be terminated.
2. When the remaining carbon capacity is less than 80 percent, a regeneration cycle will be initiated at the next opportunity when the chiller is running (after the chiller has started and no pump-out minutes have accumulated for the previous 60 minutes).
3. If there is no opportunity to purge as indicated by Rules 1 and 2 and the remaining carbon capacity is less than 50 percent, a regeneration cycle will be initiated at the best opportunity when the chiller is shutdown (and no pump-out minutes have accumulated for the previous 60 minutes).
4. If there is no opportunity to regenerate as indicated by Rules 1, 2, and 3 and the carbon capacity drops below 0 percent, then a regeneration cycle is initiated.
5. Note that, if at any time during the regeneration cycle the chiller is running and shuts down or if the chiller is off and starts up, then the regeneration cycle is continued.

Carbon Tank Regeneration Sequence

WARNING

Hazardous Voltage!

Failure to disconnect power before servicing could result in death or serious injury.

Disconnect all electric power, including remote disconnects before servicing. Follow proper lockout/tagout procedures to ensure the power can not be inadvertently energized. Verify that no power is present with a voltmeter.

Start-Up and Shutdown



Note: Graphic labels (shown above) are used for CE application only.

Important:

- Before servicing, disconnect all power sources and allow at least 30 minutes for capacitors to discharge.
- All electrical enclosures—unit or remote—are IP2X.

If the purge controller determines that carbon tank regeneration is desired and is allowed, the purge controls:

1. Disable the purge refrigeration circuit and the pump-out solenoid valve.
2. Open the regeneration solenoid valve and turn on the carbon tank heater.
3. Monitor the carbon temperature until it reaches the regeneration temperature value of 240°F (115.6°C), and control within a ±10°F (5.6°C) dead band for 15 minutes (this step should take approximately three hours).
 - If the carbon tank temperature does not increase more than 25°F (13.9°C) in the first two hours, the controller generates a non-latching diagnostic, Carbon Regeneration Temperature Too Low, and indicates a status of Carbon Regeneration Disabled. The purpose of this diagnostic is to identify a failed heater or temperature sensor. It prevents automatic regeneration from occurring, but a service technician can initiate a manual regeneration for testing purposes. All other purge algorithms continue to function.
 - If the carbon tank temperature does not reach the regeneration temperature setpoint minus 30°F (16.7°C) within four hours, the controller generates a non-latching diagnostic Purge Carbon Regeneration Temperature Not Satisfied. The purpose of this diagnostic is to identify a failing insulation system. All purge functions remain active.
4. Close the regeneration solenoid valve and turn off the heater.
 - If the carbon temperature exceeds 120 percent of the regeneration temperature setpoint, the controller issue a latching diagnostic, Purge Carbon Regeneration Temperature Limit Exceeded. The purpose of this diagnostic is to identify a failed heater relay or temperature sensor. It disables the purge and open the exhaust solenoid valve.
5. The carbon capacity is reset to 100 percent.
6. The purge refrigeration circuit is turned on to allow the carbon tank to cool for 4 hours or until the carbon temperature reaches 100°F (37.8°C), whichever comes first.
 - If the carbon temperature does not decrease more than 25°F (13.9°C) in the first hour, the controller generates a latching diagnostic Purge Regeneration Cooldown Temp Too High. The purpose of this diagnostic is to identify a failed heater relay or temperature sensor. The diagnostic will disable the purge and open the exhaust solenoid valve.
7. The exhaust solenoid will open for 5 minutes and then close.
8. The refrigeration circuit is run for 15 minutes and allows pumpouts during this time.
 - A small amount of non-condensable gas resident in the carbon tank will be returned to the chiller during a regeneration cycle. Operating the refrigeration circuit during the carbon cool-down cycle will allow time to accumulate this gas in the purge tank in readiness for the non-condensable pumpout controls to be reactivated following completion of the cool down cycle.

The complete regeneration cycle can take as long as seven hours to accomplish but an average chiller does not have to regenerate very often. A typical regeneration cycle is depicted in the following figure.

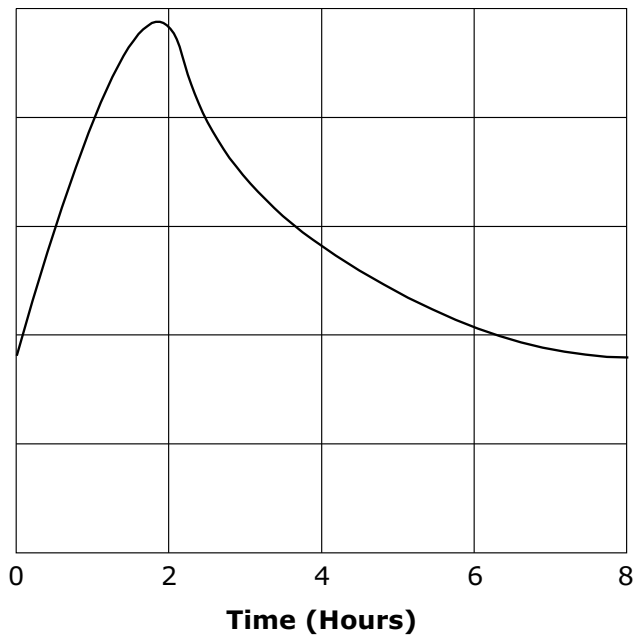
Figure 63. Typical carbon regeneration cycle

Purge Status Points

Note: The status points appear on the purge component screen of the Tracer[®] AdaptiView™ display. The purge component screen is accessible from the purge touch target on the home screen of the display.

- **Time Until Next Purge Run.** Displayed if the purge is in Adaptive mode and is idle. It indicates the amount of time left on the adaptive cycle timer.
- **Daily Pumpout—24 Hours.** Indicates the daily pumpout time for the last 24 hours (a moving 24-hour window). It indicates how the hermetic integrity of the chiller compares to historic pump-out times for the same chiller. It also allows a check against factory-recommended values.
- **Average Daily Pumpout—7 Days.** Indicates the average daily pump-out time for the last 168 hours (a moving 168-hour window). It enables a comparison of present pump-out times to past averages, and can be another indication of the hermetic integrity of the chiller.
- **Daily Pumpout Limit/Alarm.** Indicates the limit value that an operator has set in the **Settings** menu. When the daily pumpout rate exceeds this value, purge operation stops and a diagnostic is generated.
- **Chiller On—7 Days.** Indicates the percentage of time during the past seven days (floating 168-hour window) that the chiller was operating. You can use it to help determine if a leak is present on the high side or the low side of the chiller.
- **Pumpout Chiller On—7 Days.** Indicates the percentage of the total purge pump-out time during the past seven days that occurred while the chiller was operating. You can use it to help determine if a leak is present on the high side or the low side of the chiller.
- **Pumpout Chiller Off—7 Days.** Indicates the percentage of the total purge pump-out time during the past seven days that occurred when the chiller was not operating. You can use it to help determine if a leak is present on the high side or the low side of the chiller.
- **Pumpout—Life.** Indicates the total purge pump-out time that has accumulated over the life of the purge.
- **Purge Rfgr Cprsr Suction Temp.** Indicates the purge refrigerant compressor suction temperature. It is useful for diagnosing purge system problems.
- **Purge Liquid Temp.** Indicates the temperature sensed by the controller and used to inhibit purge operation. The purge liquid temperature sensor, when the chiller is operating, is the chiller saturated condenser temperature sensor; when the chiller is Off, it is the chiller saturated evaporator temperature sensor. If this temperature is below the Pumpout Inhibit Temperature that is defined in the **Settings** menu, pump-out is not allowed. This value is used to prevent inefficient operation of the purge under certain conditions.
- **Carbon Tank Temp.** Indicates the carbon bed temperature and is useful for monitoring regeneration and for diagnosing regeneration system problems.

Recommended Maintenance

⚠ WARNING

Hazardous Voltage w/Capacitors!

Failure to disconnect power and discharge capacitors before servicing could result in death or serious injury.

Disconnect all electric power, including remote disconnects and discharge all motor start/run capacitors before servicing. Follow proper lockout/tagout procedures to ensure the power cannot be inadvertently energized. For variable frequency drives or other energy storing components provided by Trane or others, refer to the appropriate manufacturer's literature for allowable waiting periods for discharge of capacitors. Verify with a CAT III or IV voltmeter rated per NFPA 70E that all capacitors have discharged.



Note: Graphic labels (shown above) are used for CE application only.

Important:

- Before servicing, disconnect all power sources and allow at least 30 minutes for capacitors to discharge.
- All electrical enclosures—unit or remote—are IP2X.

NOTICE

Check Purge Run-Time for Unit Hermetic Integrity!

Failure to follow instructions below could result in chiller damage.

If frequent purging is required, monitor purge pumpout rate, and identify and correct source of air or water leak as soon as possible to prevent moisture contamination caused by leakage.

NOTICE

Do Not Use Non-Compatible Parts or Materials!

Use of non-compatible parts or materials could result in equipment damage.

Only genuine Trane® replacement components with identical Trane part numbers should be used in Trane CenTraVac chillers. Trane assumes no responsibility for damages resulting from the use of non-compatible parts or materials.

This section describes the basic chiller preventive maintenance procedures, and recommends the intervals at which these procedures should be performed. Use of a periodic maintenance program is important to ensure the best possible performance and efficiency from a CenTraVac™ chiller.

Note: Due to the pressure vessel codes applied to CVHH CenTraVac™ chillers, the bolts used for both the economizer sump cover and the oil tank cover are specified for both ASME and PED application (SCREW, METRIC CAP-M16 x 70 mm with FULL THREAD), HEAVY HEXAGON HEAD - ASME SA-193M GRADE B7, ZINC PLATED.

Do not substitute! Contact your local Trane representative for replacement bolts.

This chiller utilizes Refrigerant Grade R-1233zd. Contact your local Trane Service Agency for proper refrigerant:

- Refrigerant MUST conform to Trane specification.
- Confirm refrigerant supplied is Solstice ZD R-1233zd Refrigerant Grade.
- Confirm every container in shipment has the marking "Solstice ZD" clearly displayed on the vessel.
- Verify Certificate of Analysis with each tank in shipment.

Record Keeping Forms

An important aspect of the chiller maintenance program is the regular completion of records. Refer to "[Appendix A: Forms and Check Sheets](#)," p. 115 for copies of the recommended forms. When filled out accurately by the machine operator, the completed logs can be reviewed to identify any developing trends in the chiller's operating conditions. For example, if the machine operator notices a gradual increase in condensing pressure during a month's time, she can systematically check and then correct the possible cause of this condition.

Normal Operation

Table 24. Normal operation

Operating Characteristic	Normal Reading
Approximate Evaporator Pressure	8 to 13.2 psia (55.2 to 91.0 kPaA) / -6.7 to -1.5 psig (-46.2 to -10.3 kPaG)
Approximate Condenser Pressure ^(a)	24.2 to 37.7 psia (166.9 to 259.9 kPaA) / 9.5 to 23 psig (65.5 to 158.6 kPaG) (standard condenser)
Oil Sump Temperature Unit not running	110°F to 135°F (43.3°C to 57.2°C)
Oil Sump Temperature Unit running	110°F to 160°F (43.3°C to 71.1°C)
Oil Sump Differential Oil Pressure ^(b)	20 to 24 psid (137.9 to 165.5 kPaD)

^(a) Condenser pressure is dependent on condenser water temperature, and should equal the saturation pressure of R-1233zd at a temperature above that of leaving condenser water at full load.

^(b) Oil tank pressure: -7 to -4 psig (-48.3 to -27.6 kPaG). Discharge oil pressure: 13 to 20 psig (89.6 to 137.9 kPaG).

NOTICE

Equipment Damage!

Failure to remove the strain relief with the sensor could result in equipment damage.

Do NOT attempt to pull sensor bulb through the strain relief; always remove the entire strain relief with the sensor.

Table 25. Recommended maintenance

Daily	Every 3 months	Every 6 months	Annually ^(a) , ^(b)
Check the chiller's evaporator and condenser pressures, oil tank pressure, differential oil pressure, and discharge oil pressure. Compare the readings with the values provided in the preceding table.			
Check the oil level in the chiller oil sump using the two sight glasses provided in the oil sump head. When the unit is operating, the oil level should be visible in the lower sight glass.			
Complete logs on a daily basis.			
	Clean all water strainers in the water piping system.		
		Lubricate the vane control linkage bearings, ball joints, and pivot points.	
		Lubricate vane operator tang O-rings.	
		Operate the tang operators manually and check for any abnormalities.	
		Drain contents of the rupture disk and purge discharge vent-line drip-leg into an evacuated waste container. Do this more often if the purge is operated excessively. Apply oil to any exposed metal parts to prevent rust.	
			Shutdown the chiller once each year to check the items listed on the "Appendix D: CenTraVac™ Chiller Annual Inspection List," p. 120 (refer to "Appendix A: Forms and Check Sheets," p. 115).
			Perform the annual maintenance procedures referred to in "Maintenance," p. 107.
			Use an ice water bath to verify the accuracy of the evaporator refrigerant temperature sensor (4BT11). If the sensor is exposed to temperature extremes outside its normal operating range (0°F to 90°F [-17.8°C to 32.2°C]), check its accuracy at six-month intervals.
			Inspect the condenser tubes for fouling; clean if necessary.



Recommended Maintenance

Table 25. Recommended maintenance (continued)

Daily	Every 3 months	Every 6 months	Annually ^(a) , ^(b)
			Inspect and clean the ifm efector® flow detection sensors. Use Scotch-Brite® or other non-abrasive material to clean scale; do NOT use steel wool, which could cause the probe to rust.
			Submit a sample of the compressor oil to a Trane-qualified laboratory for comprehensive analysis.
			Measure the compressor motor winding resistance to ground; a qualified service technician should conduct this check to ensure that the findings are properly interpreted. Contact a qualified service organization to leak-test the chiller; this procedure is especially important if the system requires frequent purging.

- (a) Every three years, use a non-destructive tube test to inspect the condenser and evaporator tubes. It may be desirable to perform tube tests on these components at more frequent intervals depending upon chiller application. This is especially true of critical process equipment. Ask your Sales account manager for a copy of engineering bulletin (CTV-PRB024*-EN) for clarification of the role of eddy current testing in chiller maintenance by providing information about eddy current technology and heat exchanger tubing.
- (b) Contact a qualified service organization to determine when to conduct a complete examination of the unit to discern the condition of the compressor and internal components. Check the following: chronic air leaks (which can cause acidic conditions in the compressor oil and result in premature bearing wear) and evaporator or condenser water tube leaks (water mixed with the compressor oil can result in bearing pitting, corrosion, or excessive wear).

Table 26. Recommended maintenance of optional features

Feature	Every 3 months	Every 6 months	Annually
Waterbox Coatings	Inspect waterbox coatings within the first 1–3 months to determine a required maintenance schedule for your job site. Refer to "Waterbox and Tubesheet Protective Coatings," p. 106 for more information.		
Waterbox Anodes	Inspect waterbox anodes within the first 1–3 months to determine a required maintenance schedule for your job site. Refer to "Sacrificial Anodes," p. 106 for more information.		
Gantries			Lubricate the gantries annually. Use ConocoPhillips MegaPlex® XD3 (gray in color), LPS® MultiPlex Multi-Purpose (blue in color), or equivalent.
Hinges			Lubricate the hinges annually. Use ConocoPhillips MegaPlex® XD3 (gray in color), LPS® MultiPlex Multi-Purpose (blue in color), or equivalent.

Recommended Compressor Oil Change

After the first six months of accumulated operation or after 1000 hours operation—whichever comes first—it is recommended to change the oil filter. It is recommended to subscribe to the Trane annual oil analysis program rather than automatically change the oil as part of scheduled maintenance. Change the oil only if indicated by the oil analysis. Using an oil analysis program will reduce the chiller's overall lifetime waste oil generation and minimize refrigerant emissions. The analysis determines system moisture content, acid level, and wear metal content of the oil, and can be used as a diagnostic tool. Due to the new refrigerant and oil combination, the oil analysis should be performed by the Trane Chemical Laboratory.

In conjunction with other diagnostics performed by a qualified service technician, oil analyses can provide valuable information on the performance of the chiller to help minimize operating and maintenance costs and maximize its operating life. An access valve is installed in the oil supply line, before the oil filter, for obtaining oil samples.

Notes:

- Use only Trane OIL00022 (2.5 gallons[9.5 L]) compressor oil and verify proper refrigerant and oil for your chiller before proceeding! A full oil change is 21 gallons (79.5 L) of oil.
- One spare compressor oil filter (per circuit) is provided with each new chiller. If not used earlier, use at first recommended compressor oil and filter change.
- This recommended compressor oil change is NOT covered by factory warranty.

Purge System

Leak Checking Based on Purge Pump Out Time

The following figure has been developed to aid in determining when to do a leak check of a chiller based on the purge pump-out time and unit size. This figure depicts normal purge pump-out times, small leaks, and large leaks based on chiller tonnage.

If the purge pump-out time is in the small leak region, then a leak check should be performed and all leaks repaired at the earliest convenience. If the purge pump-out time is in the large leak region, a thorough leak check of the unit should be performed immediately to find and fix the leaks.

Figure 64. Purge operation under typical and leak conditions

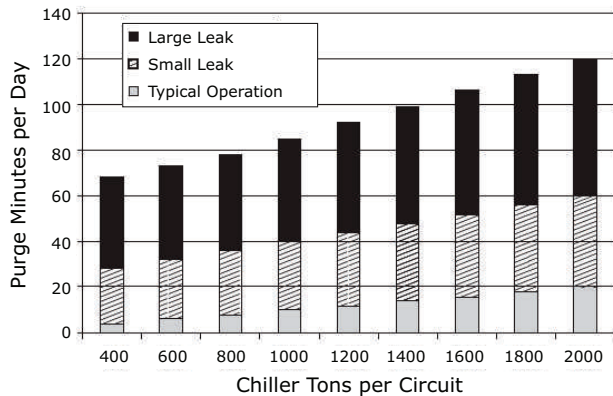

Leak Testing

⚠ WARNING

Explosion Hazard!

Failure to follow safe leak test procedures below could result in death or serious injury or equipment or property-only-damage.

Never use an open flame to detect gas leaks. Use a leak test solution for leak testing.



Note: Graphic labels (shown above) are used for CE application only.

⚠ WARNING

Hazardous Pressures!

Failure to follow instructions below could result in a violent explosion, which could result in death or serious injury.

If a heat source is required to raise the tank pressure during removal of refrigerant from cylinders, use only warm water or heat blankets to raise the tank temperature. Do not exceed a temperature of 150°F. Do not under any circumstances apply direct flame to any portion of the cylinder.

Important: If leak testing is required, contact a Trane Service Agency.

Recommended System Maintenance

NOTICE

Proper Water Treatment Required!

The use of untreated or improperly treated water could result in scaling, erosion, corrosion, algae or slime.

Use the services of a qualified water treatment specialist to determine what water treatment, if any, is required. Trane assumes no responsibility for equipment failures which result from untreated or improperly treated water, or saline or brackish water.

Condenser

Condenser tube fouling is indicated when the approach temperature (the difference between the condensing refrigerant temperature and the leaving condenser water temperature) is higher than predicted.

If the annual condenser tube inspection indicates that the tubes are fouled, two cleaning methods—mechanical and chemical—can be used to rid the tubes of contaminants. Use the mechanical cleaning method to remove sludge and loose material from smooth-bore tubes.

To clean other types of tubes including internally-enhanced types, consult a qualified service organization for recommendations.

Figure 65. Typical chemical cleaning setup

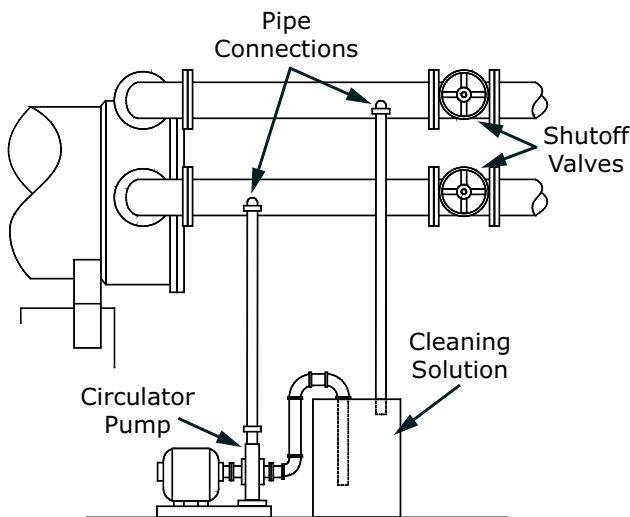

1. Follow all instructions in “Waterbox Removal and Installation,” p. 110 to remove waterbox covers.
2. Work a round nylon or brass bristled brush (attached to a rod) in and out of each of the condenser water tubes to loosen the sludge.
3. Thoroughly flush the condenser water tubes with clean water.
4. Scale deposits are best removed by chemical means. Be sure to consult any qualified chemical house in the area (one familiar with the local water supply’s chemical mineral content) for a recommended cleaning solution suitable for the job.

Note: A standard condenser water circuit is composed solely of copper, cast iron, and steel.

NOTICE

Unit Corrosion Damage!

Failure to follow instructions below could result in corrosion damage to the unit and tubes.

Follow proper procedures when using corrosive chemicals to clean water side of unit. If unsure, it is recommended that the services of a qualified chemical cleaning firm be used.

Important: All of the materials used in the external circulation system, the quantity of the solution, the duration of the cleaning period, and any required safety precautions should be approved by the company furnishing the materials or performing the cleaning. Remember, however, that whenever the chemical tube cleaning method is used, it must be followed up with mechanical tube cleaning, flushing, and inspection.

Evaporator

Since the evaporator is typically part of a closed circuit, it may not accumulate appreciable amounts of scale or sludge. Normally, cleaning every three years is sufficient. However, periodic inspection and cleaning is recommended on open evaporator systems, such as air washers.

Waterbox and Tubesheet Protective Coatings

Trane recommends that coated waterboxes/tubesheets—regardless of the type of protective coating included—be taken out of service within the first one to three months of operation for inspection. Any voids or defects identified upon inspection must be repaired. If the water quality is known to be highly supportive of corrosion (i.e., sea water, etc.), inspect the coating system at one month; if the water quality is known to be relatively benign (i.e., normal treated and clean condenser water), inspect the coating system within three months. Only when initial inspections show no problems are present should subsequent maintenance intervals be increased.

Sacrificial Anodes

The replacement schedule for the optional zinc or magnesium anodes can vary greatly with the aggressiveness of the water that is in the system. Some sites could require anode replacement every two to three months while other sites may require anode replacement every two to three years. Trane recommends inspection of anodes for wear sometime within the first several months of the anodes being placed into service. If the observed loss of anode material is small, then the interval between subsequent inspections can be lengthened. Replace the anode and/or shorten the inspection interval if the anode has lost 50 percent or more of its original mass. If anode depletion occurs very quickly, consult a water treatment specialist to determine if the anode material selected is correct for the application.

NOTICE

Equipment Damage!

Failure to follow instructions could result in equipment damage.

Do NOT use Teflon-based tape or paste on anode; a small amount of liquid sealant (Loctite® 242 or equivalent) may be applied to prevent leakage when installing an anode, but do not apply so much sealant that it prevents the necessary electrical connection between the anode and the waterbox.

As needed after draining the waterbox, use a 2-1/2 in. (63.5 mm) wrench to remove/install Trane-supplied waterbox anodes.

RuptureGuard Maintenance

It is recommended that the RuptureGuard™ be visually inspected.

The vent-line drip-leg must be periodically checked for accumulation of water or refrigerant. Drain any accumulation that may be present into an evacuated, properly labeled vessel and dispose of in accordance with local, state, and federal codes.

EarthWise Purge

Maintenance

To ensure efficient and reliable purge operation, perform all inspections and procedures at the prescribed intervals. Keep records of inspection results to establish proper service intervals. Document changes that occur in purge activity that could provide information about chiller performance.

⚠ WARNING

Refrigerant under High Pressure!

Failure to follow instructions below could result in an explosion which could result in death or serious injury or equipment damage.

System contains refrigerant under high pressure. Recover refrigerant to relieve pressure before opening the system. See unit nameplate for refrigerant type. Do not use non-approved refrigerants, refrigerant substitutes, or refrigerant additives.

⚠ WARNING

Hazardous Voltage!

Failure to disconnect power before servicing could result in death or serious injury.

Disconnect all electric power, including remote disconnects before servicing. Follow proper lockout/tagout procedures to ensure the power can not be inadvertently energized. Verify that no power is present with a voltmeter.



Note: Graphic labels (shown above) are used for CE application only.

Important:

- Before servicing, disconnect all power sources and allow at least 30 minutes for capacitors to discharge.
- All electrical enclosures—unit or remote—are IP2X.

Figure 66. Anchor for use when performing purge maintenance

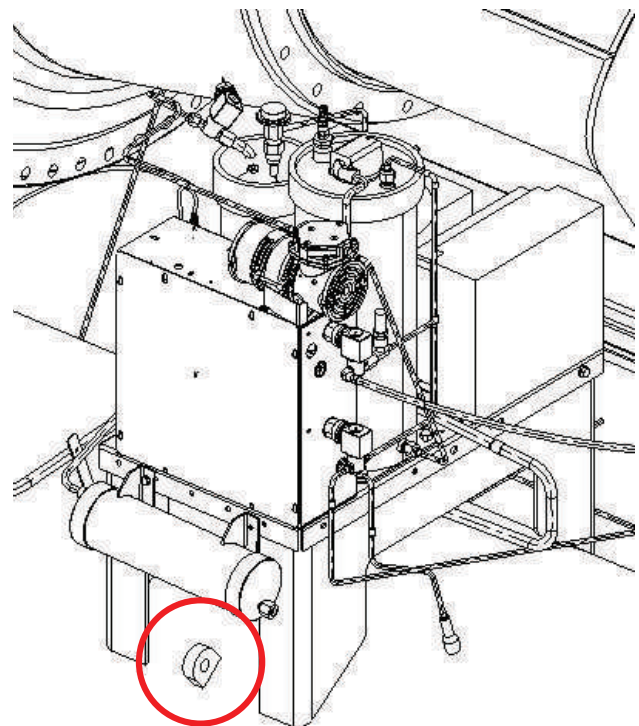

Recommended Maintenance

⚠ WARNING

Falling Off Equipment!

Failure to follow instructions below could result in a fall which could result in death or serious injury.

- When working on top of the unit, technicians **MUST** use a **COMPLETE** fall protection system: an anchor point located on the unit, a connector (positioning lanyard), and a body harness.
- The anchor point is engineered and rated as part of a complete fall protection system. It is the technicians' responsibility to use a positioning lanyard and a full body harness with the anchor.
- Technicians **MUST** be trained in hazard recognition and the proper use of personal fall protection systems.
- **ALWAYS** inspect the entire fall protection system for damage before using.
- **NEVER** modify any part of the fall protection system for any reason.

⚠ WARNING

Hot Surface!

Failure to follow instructions below could result in severe burns.

Surface temperatures may exceed 300°F (150°C). To avoid possible skin burns, stay clear of these surfaces. If possible, allow surfaces to cool before servicing. If servicing is necessary while surface temperatures are still elevated, you **MUST** put on all Personal Protective Equipment (PPE).

Weekly Maintenance

Perform the following maintenance procedure on a weekly basis:

1. With the purge unit operating, check the purge tank condensing activity by observing the liquid refrigerant flow in the moisture-indicating sight glass located in the liquid drain line immediately after the filter drier canister. A lack of visible refrigerant flow in the sight glass indicates one of the following:
 - a. A pump-out cycle is necessary.
 - b. A problem exists with the purge heat transfer circuit (such as the condensing unit, expansion device, or purge evaporator coil).
 - c. A problem exists in the purge control subsystem.
 - d. Refrigerant vapor from the chiller condenser is blocked or restricted.
2. Check the moisture-indicator sight glass. Replace the filter-drier core if moisture is indicated.

Note: The need for frequent changes of the filter drier could be an indication of significant chiller air or tube leaks.

Semi-Annual Maintenance

Perform the following maintenance procedure on a semi-annual basis:

1. Inspect the air-cooled condenser coil and clean as needed. Clean the coil from the fan side using compressed air or coil cleaner. A dirty coil will reduce purge efficiency and capacity.
2. Inspect the purge tank and carbon tank insulation for any damage or degradation. Make any needed repairs to the insulation.

Annual Maintenance

Perform the following maintenance procedure on an annual basis:

1. Semi-annual maintenance procedures described in "Semi-Annual Maintenance," p. 108.
2. Open the purge control panel and check all internal components for such problems as corrosion, terminal tightness, or signs of overheating.
3. Change the filter-drier assembly.

Inspecting the Moisture Indicator

Monitor the quality of the liquid refrigerant in the chiller by periodically inspecting the moisture indicator. The indicator will show "wet" whenever the chiller moisture exceeds the levels shown in the following table. Notice that the indicator becomes more sensitive as the temperature decreases. (The moisture indicator normally operates at equipment room ambient temperatures.).

A "wet" indication for more than 72 hours typically indicates that the filter-drier is saturated and should be replaced. In some cases in which a substantial amount of moisture has accumulated, such as when the chiller has been serviced, several filter-drier assembly changes may be required before a satisfactory moisture level is achieved. A reoccurring or persistent "wet" indication is a sign of possible chiller air or water infiltration.

Inspect the moisture indicator only under the following conditions:

- The chiller is operating.
- The purge unit is operating and has been allowed sufficient time to properly remove system moisture (allow a minimum of 72 hours after replacing filter-drier).

Table 27. R-1233zd refrigerant moisture content as determined by moisture indicator

Refrigerant moisture level	75°F (23.9°C)	100°F (37.8°C)	125°F (51.7°C)
Dry	Below 20	Below 30	Below 35
Caution	20–50	30–80	35–100
Wet	Above 50	Above 80	Above 100

Note: Refrigerant moisture content given in parts per million (ppm).

Maintaining the Moisture-Indicating Sight Glass

In normal operating conditions, the moisture-indicating sight glass should not require maintenance beyond keeping the sight glass clean. However, the sight glass should be replaced after any major repair to the unit has taken place, or if it is on a unit in which severe moisture contamination is known to have occurred.

Be aware that it is normal for the sight glass to indicate the presence of moisture for a period of least 72 hours after it is installed and after it has been exposed to atmosphere. Allow a minimum of 72 hours after sight glass installation or filter-drier service before using the sight glass to determine the system moisture content.

Removing Air After Servicing the Chiller

Air that leaks into a chiller during servicing needs to be removed so that the chiller can operate normally. The

purge pump-out system, which performs this function, may operate for a long time to remove the air before cycling off for the first time. This is due to the large amount of non-condensables and the relatively small amount of refrigerant being drawn into the purge tank.

Important: Do NOT bypass or remove the pump-out restrictor of the EarthWise™ purge system. Doing so could reduce the efficiency of the purge system. The purge system has a faster air exhaust rate than previous purge systems, which makes bypassing or removing the restrictor unnecessary.

The Daily Pumpout Limit determines how long the purge pump-out compressor can operate continuously without generating a Purge Daily Pumpout Exceeded diagnostic, which will shut off the purge system. You can disable the Daily Pumpout Limit to allow the purge to pump out for an extended period of time.

After the level of non-condensables present in the chiller falls to a point in which an increasing amount of refrigerant enters the purge tank, the pump-out compressor begins to cycle on and off. As the refrigerant in the system becomes less contaminated with non-condensables, purge pump-out is activated less frequently.

Note: If large amounts of non-condensables are present in the chiller, the air removal rate can be enhanced by operating the chiller at part-load conditions.



Waterbox Removal and Installation

Important: Only qualified technicians should perform the installation and servicing of this equipment.

Discussion

This section will discuss recommended lifting. Proper lifting technique will vary based on mechanical room layout.

- It is the responsibility of the person(s) performing the work to be properly trained in the safe practice of rigging, lifting, securing, and fastening of the waterbox.
- It is the responsibility of the person(s) providing and using the rigging and lifting devices to inspect these devices to ensure they are free from defect and are rated to meet or exceed the published weight of the waterbox.
- Always use rigging and lifting devices in accordance with the applicable instructions for such device.

Procedure

⚠ WARNING

Heavy Objects!

Failure to properly lift waterbox could result in death or serious injury.

Each of the individual cables (chains or slings) used to lift the waterbox must be capable of supporting the entire weight of the waterbox. The cables (chains or slings) must be rated for overhead lifting applications with an acceptable working load limit. Refer to the waterbox weights table.

Note: Refer to "Torque Requirements and Waterbox Weights," p. 111 for waterbox weights.

⚠ WARNING

Straight Vertical Lift Required!

Failure to properly lift waterbox in straight vertical lift could cause the eyebolts to break which could result in death or serious injury from object dropping.

The proper use and ratings for eyebolts can be found in ANSI/ASME standard B18.15. Maximum load rating for eyebolts are based on a straight vertical lift in a gradually increasing manner. Angular lifts will significantly lower maximum loads and should be avoided whenever possible. Loads should always be applied to eyebolts in the plane of the eye, not at some angle to this plane.

Review mechanical room limitations and determine the safest method or methods of rigging and lifting the waterboxes.

1. Determine the type and size of chiller being serviced. Refer to Trane® nameplate located on chiller control panel.

Important: This section contains rigging and lifting information only for Trane® CenTraVac™ chillers built in La Crosse. For Trane® CenTraVac™ chillers built outside the United States, refer to literature provided by the applicable manufacturing location.

2. The rated lifting capacity of the lifting shackle must meet or exceed the published weight of the waterbox. Verify the waterbox weight from the latest published literature.
3. Ensure that the lift connection device has the correct size for the waterbox lifting hole.
4. Properly connect the shackle to the waterbox. Refer to the following figure
5. Disconnect water pipes, if connected.
6. Remove hex head bolts.
7. Lift the waterbox away from the shell.

⚠ WARNING

Overhead Hazard!

Failure to follow instructions could result in death or serious injuries.

Never stand below or in close proximity to heavy objects while they are suspended from, or being lifted by, a lifting device in case the object drops.

8. Store waterbox in a safe and secure location and position.

Note: Do NOT leave waterbox suspended from lifting device.

Figure 67. Waterbox lifting—condenser and evaporator lifting points

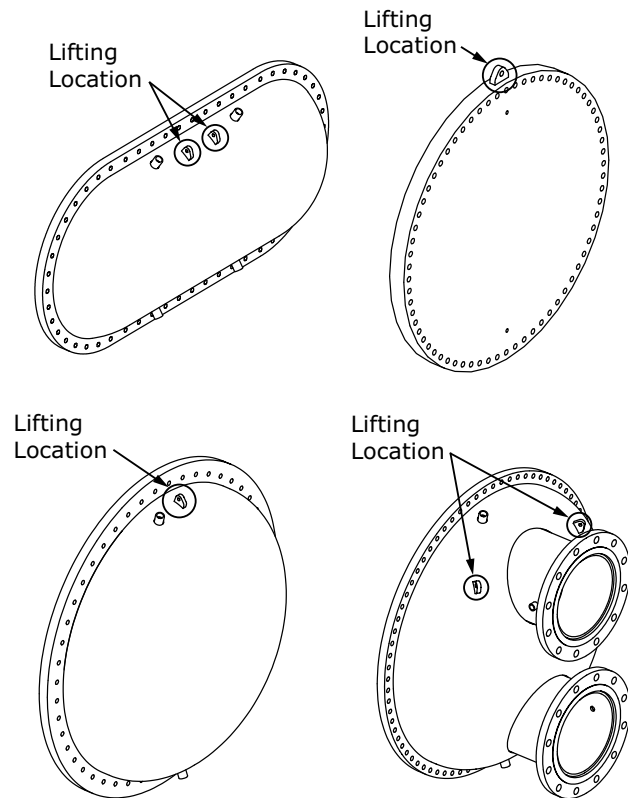

Reassembly

Once service is complete, the waterbox should be reinstalled on the shell following all previous procedures in reverse. Use new O-rings or gaskets on all joints after thoroughly cleaning each joint.

Important: Torque waterbox screws as specified in “*Torque Requirements and Waterbox Weights*,” p. 111.

Torque Requirements and Waterbox Weights

Note: CVHH CenTraVac™ chillers are assembled with metric fasteners.

Table 28. CenTraVac chiller screw torques — metric

Screw Size ^(a)	Torque ^(b)		Wrench Size for ANSI/ISO ^(c) Bolts (mm)
	ft·lb	N·m	
M5–0.8	54–66 (in-lb)	6–8	8
M6–1.0	86–105 (in-lb)	10–12	10
M8–1.25	17–21	23–28	13
M10–1.5	34–42	46–57	16
M12–1.75	60–72	81–98	19
M14–2.0	95–115	129–156	21
M16–2.0	148–180	200–244	24
M18–2.5	203–247	275–335	30
M20–2.5	288–348	390–472	36

^(a) Grade 8.8 metric fasteners

^(b) If threads are lubricated, reduce torque value by 25%.

^(c) ANSI = American National Standards Institute, ISO = International Organization for Standards



Waterbox Removal and Installation

Table 29. Waterbox weights (IP units)

Shell Size	Description	Non-Marine Plate		Non-Marine Dome		Marine Plate Cover		Marine Dome Cover		Marine Waterbox	
		Weight (lb)	Lifting Hole (in.)	Weight (lb)	Lifting Hole (in.)	Weight (lb)	Lifting Hole (in.)	Weight (lb)	Lifting Hole (in.)	Weight (lb)	Lifting Hole (in.)
100	Evaporator, 150 psig	—	—	693	0.469	—	—	569	0.469	1292	0.858
	Evaporator, 300 psig	617	0.469	—	—	814	0.469	—	—	1365	1.38
	Condenser, 150 psig	—	—	448	0.469	—	—	324	0.469	953	0.858
	Condenser, 300 psig	—	—	642	0.469	—	—	436	0.469	1195	0.858
130	Evaporator, 150 psig	—	—	766	0.469	—	—	645	0.469	1423	0.858
	Evaporator, 300 psig	731	0.469	—	—	705	0.469	—	—	1527	1.38
	Condenser, 150 psig	—	—	589	0.469	—	—	409	0.469	1166	0.858
	Condenser, 300 psig	—	—	851	0.469	—	—	562	0.469	1513	0.858
160	Evaporator, 150 psig	—	—	863	0.469	—	—	683	0.469	1813	0.858
	Evaporator, 300 psig	919	0.469	—	—	906	0.469	—	—	1937	1.38
200	Evaporator, 150 psig	—	—	652	0.469	1282	0.469	—	—	2295	1.38
	Evaporator, 300 psig	1981	0.469	—	—	1763	0.469	—	—	2849	1.38
	Condenser, 150 psig	—	—	700	0.469	—	0.469	—	—	1544	0.858
	Condenser, 300 psig	—	—	—	0.469	1724	0.469	—	—	2138	0.858
220	Evaporator, 150 psig	—	—	802	0.469	1702	0.469	—	—	3068	1.38
	Evaporator, 300 psig	—	—	1581	0.469	2476	0.469	—	—	4137	1.38
	Condenser, 150 psig	—	—	763	0.469	—	—	543	0.469	1598	0.858
	Condenser, 300 psig	—	—	1132	0.469	—	—	708	0.469	1901	0.858
10H	Heat Recovery Condenser, 150 psig	2022	0.858	—	—	—	—	—	—	—	—
13H	Heat Recovery Condenser, 150 psig	2439	0.858	—	—	—	—	—	—	—	—
20H	Heat Recovery Condenser, 150 psig	2750	0.858	—	—	—	—	—	—	—	—
22H	Heat Recovery Condenser, 150 psig	3853	0.858	—	—	—	—	—	—	—	—

Table 30. Waterbox weights (SI units)

Shell Size	Description	Non-Marine Plate		Non-Marine Dome		Marine Plate Cover		Marine Dome Cover		Marine Waterbox	
		Weight (kg)	Lifting Hole (mm)	Weight (kg)	Lifting Hole (mm)	Weight (kg)	Lifting Hole (mm)	Weight (kg)	Lifting Hole (mm)	Weight (kg)	Lifting Hole (mm)
100	Evaporator, 1034.2 kPaG	—	—	314	11.9	—	—	258	11.9	586	21.8
	Evaporator, 2068.4 kPaG	280	11.9	—	—	369	11.9	—	—	619	35.1
	Condenser, 1034.2 kPaG	—	—	203	11.9	—	—	147	11.9	432	21.8
	Condenser, 2068.4 kPaG	—	—	291	11.9	—	—	198	11.9	542	21.8
130	Evaporator, 1034.2 kPaG	—	—	347	11.9	—	—	292	11.9	645	21.8
	Evaporator, 2068.4 kPaG	331	11.9	—	—	320	11.9	—	—	693	35.1
	Condenser, 1034.2 kPaG	—	—	267	11.9	—	—	185	11.9	529	21.8
	Condenser, 2068.4 kPaG	—	—	386	11.9	—	—	255	11.9	686	21.8
160	Evaporator, 1034.2 kPaG	—	—	391	11.9	—	—	310	11.9	822	21.8
	Evaporator, 2068.4 kPaG	416	11.9	—	—	411	11.9	—	—	878	35.1
200	Evaporator, 1034.2 kPaG	—	—	295	11.9	581	11.9	—	—	1041	35.1
	Evaporator, 2068.4 kPaG	898	11.9	—	—	799	11.9	—	—	1292	35.1
	Condenser, 1034.2 kPaG	—	—	317	11.9	—	11.9	—	—	700	21.8
	Condenser, 2068.4 kPaG	—	—	—	11.9	782	11.9	—	—	970	21.8
220	Evaporator, 1034.2 kPaG	—	—	364	11.9	772	11.9	—	—	1392	35.1
	Evaporator, 2068.4 kPaG	—	—	717	11.9	1123	11.9	—	—	1876	35.1
	Condenser, 1034.2 kPaG	—	—	346	11.9	—	—	246	11.9	724	21.8
	Condenser, 2068.4 kPaG	—	—	513	11.9	—	—	321	11.9	862	21.8
10H	Heat Recovery Condenser, 1034.2 kPaG	917	21.8	—	—	—	—	—	—	—	—
13H	Heat Recovery Condenser, 1034.2 kPaG	1106	21.8	—	—	—	—	—	—	—	—
20H	Heat Recovery Condenser, 1034.2 kPaG	1247	21.8	—	—	—	—	—	—	—	—
22H	Heat Recovery Condenser, 1034.2 kPaG	1747	21.8	—	—	—	—	—	—	—	—

Screw-Tightening Sequence for Waterboxes

Evaporator Waterbox Covers

Ensure that the waterbox head rests tightly against the tube sheet, and then snugly tighten the screws in sequential order as shown in the following figure. If excessive tube sheet crown prevents the head from contacting the tube sheet, tighten the screws located where the greatest gaps occur. Be sure to use an equal number of screw turns from side to side. Then, apply final torque to each screw in sequential order.

Figure 68. Evaporator waterbox cover screw tightening sequence

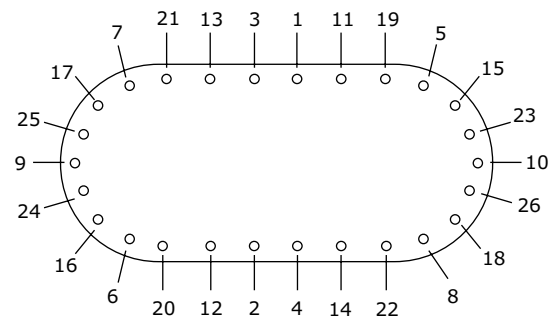

Condenser Waterbox Covers

Condenser waterbox covers use a similar procedure to that which is used for the evaporator waterbox covers. Use a crossing pattern as shown in the following figure.

Waterbox Removal and Installation

Figure 69. Condenser waterbox cover screw tightening sequence

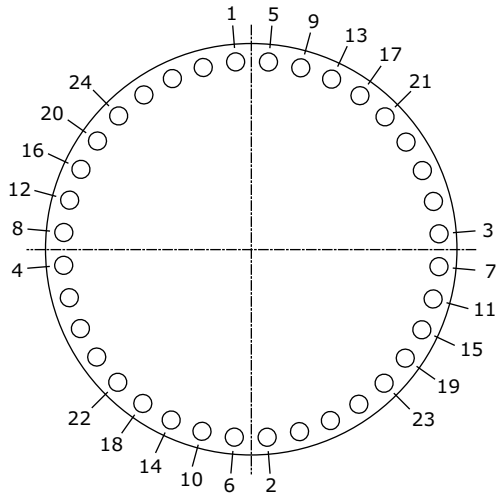

Heat Recovery Condenser Waterbox Covers

For heat recovery condenser waterbox covers, torque the screws along the center divider of the waterbox first (1A,

2A, 3A, etc), and then torque the screws around the outside of the waterbox (1B, 2B, 3B, etc).

Figure 70. Heat recovery condenser waterbox cover screw tightening sequence

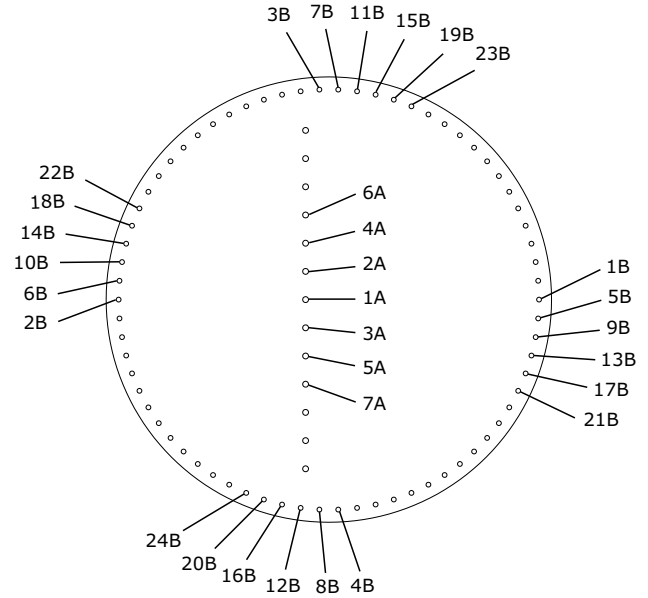



Appendix A: Forms and Check Sheets

The following forms and check sheets are included for use with Trane start-up of CVHH CenTraVac™ chillers. Forms and check sheets are used, as appropriate, for installation completion verification before Trane start-up is scheduled, and for reference during the Trane start-up.

Where the form or check sheet also exists outside of this publication as standalone literature, the literature order number is also listed.

- CTV Form — Installation Completion and Request for Trane Service (CTV-ADF001*-EN)
- CenTraVac Chiller Start-up Tasks to be Performed by Trane
- CenTraVac Chiller Annual Inspection List

- CenTraVac Operator Log

Unit Start-Up/Commissioning

Important: *Start-up must be performed by Trane or an agent of Trane specifically authorized to perform start-up and warranty of Trane® products. Contractor shall provide Trane (or an agent of Trane specifically authorized to perform start-up) with notice of the scheduled start-up at least two weeks prior to the scheduled start-up.*



Appendix B: Chiller Installation Completion and Request for Trane Service

Important: A copy of this completed form must be submitted to the Trane Service Agency that will be responsible for the start-up of the chiller. Start-up will NOT proceed unless applicable items listed in this form have been satisfactorily completed.

To: _____

Trane Service Office: _____

S.O. Number: _____

Serial Numbers: _____

Job/Project Name: _____

Address: _____

The following items are being installed and will be completed by: _____

Important: Start-up must be performed by Trane or an agent of Trane specifically authorized to perform start-up and warranty of Trane® products. Contractor shall provide Trane (or an agent of Trane specifically authorized to perform start-up) with notice of the scheduled start-up at least two weeks prior to the scheduled start-up. **Equipment not started by Trane is not warranted by Trane.**

Notes: Improper installation of CenTraVac™ chillers, including optional components, can result in start-up delay and required rework. Follow all provided instructions and in use particular care with optional devices:

- Follow installation procedures for RuptureGuard™; refer to CTV-SVX06*-EN for CDHF, CDHG, CVHE, CVHF, CVHG, and CVHM models, refer to CDHH-SVX003*-EN for CDHH models, and refer to CVHH-SVX003*-EN for CVHH CenTraVac™ chiller models.
 - Do NOT over-insert or over-torque the probe of the ifm efector™ flow detection controller and sensor; refer to PART-SVN223*-EN or the CenTraVac™ chiller Installation, Operation, and Maintenance manual.
 - Do NOT block serviceable parts when installing isolation springs.
- Expenses that result in improper installation of CenTraVac™ chillers, including optional components, will NOT be paid by Trane.

Check box if the task is complete or if the answer is "yes".

1. Chiller

- In place and piped.

Note: Do not insulate the CenTraVac™ chiller or adjacent piping prior to the chiller commissioning by Trane service personnel. The contractor is responsible for any foreign material left in the unit.

2. Piping

Chilled water piping connected to:

- CenTraVac™ chiller
- Air handling units
- Pumps
- Optional ifm efector® flow detection controller and sensor properly installed

Condenser and heat recovery condenser (as applicable) piping connected to:

- CenTraVac™ chiller
- Pumps
- Cooling tower
- Heating loop (as applicable)

Additional piping:

- Make-up water connected to cooling tower
- Water supply connected to filling system
- Systems filled
- Pumps run, air bled from system
- Strainers cleaned
- Rupture disk or RuptureGuard™ ventilation piping properly installed
- Optional RuptureGuard™ properly installed

3. Flow balancing valves installed

- Leaving chilled water
- Leaving condenser water
- Optional heat recovery or auxiliary condenser water

4. Gauges, thermometers, and air vents

- Installed on both sides of evaporator
- Installed on both sides of condenser and heat recovery condenser (as applicable)

5. Wiring

- Compressor motor starter has been furnished by Trane, or has been configured and installed in compliance with the appropriate Trane Engineering Specification for Starter by Others (available from your local Trane Sales Office)

Appendix B: Chiller Installation Completion and Request for Trane Service

- Full power available
- Interconnecting wiring, starter to panel (as required)
- External interlocks (flow switch, pumps auxiliary, etc.)
- Chiller motor connection (remote starters)

Note: Do not make final remote starter-to compressor motor connections until requested to do so by the Trane service representative!

- Chilled water pump (connected and tested)
- Condenser water pump (connected and tested)
- Optional ifm efector® flow detection controller and sensor cable properly installed and secured for non-stress at probe connector
- Cooling tower fan rotation checked
- Heat recovery condenser water pump (as applicable)
- 115 Vac power available for service tools
- All controls installed and connected
- Indicate type of power distribution grounding
- All magnetic starters installed and connected

6. Testing

- Dry nitrogen available for pressure testing (for disassembled units)
- Material and equipment available for leak testing (if necessary)

7. Refrigerant

- For CDHH and CVHH chillers: Verify supplied refrigerant is "Solstice ZD" Refrigeration Grade by checking certificates provided with tanks.
- Refrigerant on job site and in close proximity to chiller

Total amount in cylinders/drums: _____
(specify lb or kg) and fill in specifics below:

Number of cylinders/drums _____ of size _____
(specify lb or kg)

Number of cylinders/drums _____ of size _____
(specify lb or kg)

Note: After commissioning is complete, it is the installer's responsibility to transport empty refrigerant containers to an easily accessible point of loading to facilitate container return or recycling.

8. System

- Systems can be operated under load conditions.

9. Availability

- Electrical, control personnel, and contractor's representative are available to evacuate, charge,

and test the CenTraVac™ chiller under serviceman's supervision.

10. Equipment room

- Does the equipment room have a refrigerant monitor/sensor capable of monitoring and alarming within the allowable exposure level of the refrigerant?
- Does the installation have properly placed and operating audible and visual refrigerant alarms?
- Does the equipment room have proper mechanical ventilation?
- If it is required by local code, is a self-contained breathing apparatus available?

11. Owner awareness

- Has the owner been fully instructed on the proper use and handling of refrigerant?
- Does the owner have a copy of the MSDS for refrigerant?

Note: Additional time required to properly complete the start-up and commissioning, due to any incompleteness of the installation, will be invoiced at prevailing rates.

This is to certify that the Trane equipment has been properly and completely installed, and that the applicable items listed above have been satisfactorily completed.

Checklist completed by:
(Print Name): _____

Signed: _____

Date: _____

In accordance with your quotation and our purchase order number _____, we therefore require the presence of Trane service on this site, for the purpose of start-up and commissioning, by _____ (date).

Note: Minimum of two week advance notification is required to allow for scheduling of the chiller start-up.

Additional Comments/Instructions:



Appendix C: CenTraVac™ Chiller Start-Up Tasks to be Performed by Trane

⚠ WARNING

Safety Alert!

Failure to follow instructions below could result in death or serious injury.

In addition to the following tasks, you **MUST**:

- Follow all instructions in the unit's *Installation, Operation, and Maintenance* manual, including warnings, cautions, and notices.
- Perform all required tasks in any applicable Service Alerts and Service Bulletins.
- Review and understand all information provided in Submittals and Design Specifications.

1. General

- Inspect chiller for damage (shipping or rigging).
- Verify and record unit nitrogen holding charge pressure.
- Inspect water piping for proper installation.
 - Inspect strainers, flow sensing devices, isolation valves, pressure gauges, thermometer wells, flow balancing valves, vent cocks, and drains.
 - Inspect cooling tower piping.
- Verify proper clearances.
- Power wiring meets size requirement.
 - Verify proper voltage and amperage rating.
- Verify proper foundation installation.
- Verify unit isolator pads/springs have been installed.
- Verify low voltage circuits are isolated from high voltage circuits.
- Check equipment room for ventilation, refrigerant monitor, rupture disk piping, and Personal Protective Equipment (PPE).

Note: All conditions which do not conform to the established requirements for unit installation **MUST** be corrected prior to start-up. Any non-conforming condition which is not corrected prior to start-up must be noted in the Non-Compliance Form (PROD-ADF001*-EN) by the start-up technician; this information must also be signed by responsible site personnel before start-up and the completed Non-Compliance Form will become part of the start-up record, submitted with a Start-up Check Sheet and a Chiller Service Report.

2. Pre-Start Operations

- Verify nitrogen holding charge.
- Calibrate the high pressure cutout control (HPC).
- Meg compressor motor.
- Check condenser installation.
- Check evaporator installation.

NOTICE

Do Not Apply Electrical Power to a Unit in a Vacuum!

Failure to follow instructions below could result in motor and compressor damage.

Do not apply electrical power to a motor in a vacuum.

For units with inside-the-delta solid state starters, disconnect power to unit during evacuation or when the unit is in a deep vacuum. In addition, on units with inside-the-delta solid state starters, all power to the unit must be disconnected prior to evacuating the unit as line power is directly applied to the motor terminals 4, 5, and 6.

- Check electrical and controls.
 - Inspect motor starter and control panel.
 - Confirm all wiring connections are tight, free of abrasion and have no sharp bends in panel and on compressors.
 - Inspect contactors and relays.
 - Verify unit wiring (low and high voltage) is correctly isolated, phased, and properly grounded.
 - Connect external 120 Vac power to power up the control panel.
 - Run the oil pump to verify pump can provide (20 to 24 psid) 137.9 to 165.5 kPaD net pressure.
 - Verify and record control parameters.
 - Verify all control interlocks are installed and properly functioning.
 - Set AFD grounding jumpers (PE-A for MOV and PEB for Common Mode) for power distribution grounding:
 - Both jumpers "Connected" for Solidly Grounded System (Center Ground Wye).
 - Both jumpers "Disconnected" for Non Solidly Grounded System (Any Delta, High Impedance Ground, or Ungrounded Wye).

Appendix C: CenTraVac™ Chiller Start-Up Tasks to be Performed by Trane

Note: Refer to AFD-SVG002*-EN for more information.

- Dry run starter (non-Adaptive Frequency™ Drive [AFD]).
 - Measure condenser pressures and flow.
 - Adjust condenser flow sensing device.
 - Measure evaporator pressures and flow.
 - Adjust evaporator flow sensing device.
 - Inspect motor starter panel and perform starter panel checkout procedures.
 - Confirm proper phase check incoming power.
 - Inspect control panel.
 - Apply separate source 120 Vac power to control to perform control panel checkout procedure.
 - Review and record unit configuration parameters.
 - Verify the operation of the oil tank vent valve.
 - Verify that the oil cooling line valve actuates.
 - Verify vane operator is working properly and moves without binding.
 - Dry run test starter (non-AFD).
 - Remove separate source power and reconnect wiring.
3. **Preparation for Start-up**
- Relieve nitrogen holding charge.
 - Confirm proper oil pump operation.
 - Confirm oil pump pressure—regulating valve setting.
 - Evacuate and charge the system.
 - Apply power to the starter panel.
- Verify current to the oil sump heater.
4. **Chiller Start-up**
- Set Purge mode to “On.”
 - Bump-start the compressor and verify compressor motor rotation.
 - Start chiller.
 - Verify no unusual noises or vibrations and observe operating conditions.
 - If necessary, adjust oil pressure regulator between 20 to 24 psid (137.9 to 165.5 kPaD) net.
 - Measure and verify refrigerant pump pressure.
 - When chiller is stable, take system log three times at 15-minute intervals.
 - Set Purge mode to “Adaptive.”
 - Reset the “Starter Energy Consumption” resettable.
 - Record a *Chiller Service Report*.
 - Review “AdaptiView Display Customer Training Checklist.”
 - Equipment Description
 - Stopping/Starting Chiller Operation
 - Alarms
 - Reports
 - Data Graphs
 - Equipment Settings
 - Display Settings
 - Security Settings
 - Basic Troubleshooting



Appendix D: CenTraVac™ Chiller Annual Inspection List

Follow the annual maintenance instructions provided in the text of this manual, including but not limited to:

1. Compressor/Motor

- Motor continuity.
- Motor meg test.
- Check motor terminals.
- Inspect motor terminal board.
- Check inlet guide vanes (IGV) for abnormalities.

2. Starter or Adaptive Frequency™ Drive

- Inspect starter contacts.
- Check all connections per manufacturer specifications.
- Follow all manufacturer recommendations for starter or Adaptive Frequency™ Drive (AFD) maintenance.
- Inspect/clean/service the AFD cooling system (water- or air-cooled AFD).
- Record all applicable starter or starter component settings.

3. Oil System

- Annual oil analysis (follow recommendations).
- Clean and lubricate oil system as required.
- Electrical inspection.
- Pump motor continuity check.
- Run oil pump and check differential oil pressure.

4. Condenser

- Inspect for fouling and scaling in tubes.
- Check operation of condenser water flow sensing device.
- Factory recommendation to eddy current test tubes every three years.

5. Evaporator

- Inspect for fouling and scaling in tubes.
- Check operation of evaporator water flow sensing device.
- Factory recommendation to eddy current test tubes every three years.

6. Control Circuits

- Verify control parameters.
- Test appropriate sensors for accuracy.
- Ensure sensors are properly seated in wells with thermopaste installed.
- Check evaporator leaving water temperature low temperature cutout setpoint.
- Condenser high pressure switch check-out.
- Check adjustment and operation of the inlet guide vane actuator.

7. Leak Test Chiller

- Check purge times and unit performance logs. If warranted, pressure leak test.
- Review oil analysis. If required, submit refrigerant sample for analysis.
- Inspect unit for any signs of refrigerant or oil leakage.
- Check unit for any loose screws on flange, volutes, or casing.

8. Purge Unit

- Review the purge the purge sections of this manual and follow maintenance and/or inspection items identified.
- Review purge pump-out data.
- Review overall operation of purge and service as necessary.

9. Exterior

- Inlet guide vane linkage.
- Clean and touch-up painted surfaces as needed.
- Repair deteriorated, torn, or missing insulation.

10. Optional Accessories

- If applicable, lubricate factory-installed gantries.
- After the first month of operation, inspect Heresite® or Belzona® coated waterboxes; thereafter, inspect as needed.
- Inspect anodes.
- Inspect and lubricate hinged waterboxes.
- With water flow sensing option, bleed tubing from waterboxes to transformers.



Appendix E: CVHH CenTraVac™ Chiller Operator Log

Water-Cooled CenTraVac™ Chillers with Symbio Controller			
Tracer® AdaptiView™ Reports — Log Sheet	Log 1	Log 2	Log 3
Evaporator			
Active Chilled Water Setpoint			
Evaporator Entering Water Temperature			
Evaporator Leaving Water Temperature			
Evaporator Approach Temperature			
Evaporator Saturated Rfgt Temp			
Evaporator Refrigerant Pressure			
Evaporator Water Flow Status			
Approximate Evaporator Water Flow			
Evaporator Water Pump Override			
Evaporator Differential Water Pressure			
Condenser			
Active Hot Water Setpoint			
Condenser Entering Water Temperature			
Condenser Leaving Water Temperature			
Condenser Approach Temperature			
Condenser Saturated Rfgt Temp			
Condenser Refrigerant Pressure			
Condenser Water Flow Status			
Approximate Condenser Water Flow			
Condenser Water Pump Override			
Condenser Differential Water Pressure			
Differential Refrigerant Pressure			
Condenser Refrigerant Liquid Level			
Compressor			
Compressor Running Status			
Compressor Starts			
Compressor Running Time			
Oil Pump Discharge Pressure			
Oil Tank Pressure			
Oil Differential Pressure			
Oil Tank Temperature			
Oil Differential Pressure Switch			
IGV 1 Percent Open			
IGV 2 Percent Open			
Outboard Bearing Pad Temperature 1			
Outboard Bearing Pad Temperature 2			
Outboard Bearing Pad Temperature 3			
Motor			
Active Demand Limit Setpoint			
Average Motor Current % RLA			
AFD Percent Speed			
AFD Calculated Motor Voltage			
Chiller Load Command			
Starter Motor Current L1 % RLA			
Starter Motor Current L2 % RLA			
Starter Motor Current L3 % RLA			



Appendix E: CVHH CenTraVac™ Chiller Operator Log

Water-Cooled CenTraVac™ Chillers with Symbio Controller			
Tracer® AdaptiView™ Reports — Log Sheet	Log 1	Log 2	Log 3
Starter Motor Current L1			
Starter Motor Current L2			
Starter Motor Current L3			
Starter Input Voltage AB			
Starter Input Voltage BC			
Starter Input Voltage CA			
Average Motor Current			
AFD Motor Current U % RLA			
AFD Motor Current V % RLA			
AFD Motor Current W % RLA			
AFD Motor Current U			
AFD Motor Current V			
AFD Motor Current W			
AFD Motor Voltage UV			
AFD Motor Voltage VW			
AFD Motor Voltage WU			
Unit Power Consumption			
Chiller Power Demand			
Starter Motor Power Factor			
Motor Winding Temperature 1			
Motor Winding Temperature 2			
Motor Winding Temperature 3			
Motor Temperature			
MTC Switch			
Motor Coolant Temperature			
Speed Command			
Motor Speed			
Motor Frequency or Frequency Command			
AFD Transistor Temperature			
AFD Heatsink Temperature			
Purge			
Daily Pumpout 24 Hours			
Average Daily Pumpout 7 Days			
Daily Pumpout Limit			
Chiller On 7 Days			
Pumpout Chiller On 7 Days			
Pumpout Chiller Off 7 Days			
Time Until Next Purge Run			
Purge Rfgt Compressor Suction Temp			
Purge Liquid Temperature			
Pumpout Life			
Purge Carbon Tank Temperature			
Date:			
Technician:			
Owner:			

Trane - by Trane Technologies (NYSE: TT), a global innovator - creates comfortable, energy efficient indoor environments for commercial and residential applications. For more information, please visit trane.com or tranetechnologies.com.

Trane has a policy of continuous product and product data improvements and reserves the right to change design and specifications without notice. We are committed to using environmentally conscious print practices.

CVHH-SVX003D-EN 16 Dec 2023
Supersedes CVHH-SVX003C-EN (April 2023)

©2024 Trane