



Installation, Operation, and Maintenance

CenTraVac® Water-cooled Chillers

Models CVHE, CVHF, and CVHG

With Symbio™ Controls



Models: CVHE, CVHF, CVHG

X39641427005

▲ SAFETY WARNING

Only qualified personnel should install and service the equipment. The installation, starting up, and servicing of heating, ventilating, and air-conditioning equipment can be hazardous and requires specific knowledge and training. Improperly installed, adjusted or altered equipment by an unqualified person could result in death or serious injury. When working on the equipment, observe all precautions in the literature and on the tags, stickers, and labels that are attached to the equipment.

April 2026

CVHE-SVX005E-EN

TRANE
TECHNOLOGIES™



Introduction

Read this manual thoroughly before operating or servicing this unit.

Warnings, Cautions, and Notices

Safety advisories appear throughout this manual as required. Your personal safety and the proper operation of this machine depend upon the strict observance of these precautions.

The three types of advisories are defined as follows:



Indicates a potentially hazardous situation which, if not avoided, could result in death or serious injury.



Indicates a potentially hazardous situation which, if not avoided, could result in minor or moderate injury. It could also be used to alert against unsafe practices.



Indicates a situation that could result in equipment or property-damage only accidents.

Important Environmental Concerns

Scientific research has shown that certain man-made chemicals can affect the earth's naturally occurring stratospheric ozone layer when released to the atmosphere. In particular, several of the identified chemicals that may affect the ozone layer are refrigerants that contain Chlorine, Fluorine and Carbon (CFCs) and those containing Hydrogen, Chlorine, Fluorine and Carbon (HCFCs). Not all refrigerants containing these compounds have the same potential impact to the environment. Trane advocates the responsible handling of all refrigerants.

Important Responsible Refrigerant Practices

Trane believes that responsible refrigerant practices are important to the environment, our customers, and the air conditioning industry. All technicians who handle refrigerants must be certified according to local rules. For the USA, the Federal Clean Air Act (Section 608) sets forth the requirements for handling, reclaiming, recovering and recycling of certain refrigerants and the equipment that is used in these service procedures. In addition, some states or municipalities may have additional requirements that must also be adhered to for responsible management of refrigerants. Know the applicable laws and follow them.

⚠ WARNING

Proper Field Wiring and Grounding Required!

Failure to follow code could result in death or serious injury.

All field wiring **MUST** be performed by qualified personnel. Improperly installed and grounded field wiring poses **FIRE** and **ELECTROCUTION** hazards. To avoid these hazards, you **MUST** follow requirements for field wiring installation and grounding as described in **NEC** and your local/state/national electrical codes.

⚠ WARNING

Personal Protective Equipment (PPE) Required!

Failure to wear proper PPE for the job being undertaken could result in death or serious injury.

Technicians, in order to protect themselves from potential electrical, mechanical, and chemical hazards, **MUST** follow precautions in this manual and on the tags, stickers, and labels, as well as the instructions below:

- **Before installing/servicing this unit, technicians MUST put on all PPE required for the work being undertaken (Examples; cut resistant gloves/sleeves, butyl gloves, safety glasses, hard hat/bump cap, fall protection, electrical PPE and arc flash clothing). ALWAYS refer to appropriate Safety Data Sheets (SDS) and OSHA guidelines for proper PPE.**
- **When working with or around hazardous chemicals, ALWAYS refer to the appropriate SDS and OSHA/GHS (Global Harmonized System of Classification and Labelling of Chemicals) guidelines for information on allowable personal exposure levels, proper respiratory protection and handling instructions.**
- **If there is a risk of energized electrical contact, arc, or flash, technicians MUST put on all PPE in accordance with OSHA, NFPA 70E, or other country-specific requirements for arc flash protection, PRIOR to servicing the unit. NEVER PERFORM ANY SWITCHING, DISCONNECTING, OR VOLTAGE TESTING WITHOUT PROPER ELECTRICAL PPE AND ARC FLASH CLOTHING. ENSURE ELECTRICAL METERS AND EQUIPMENT ARE PROPERLY RATED FOR INTENDED VOLTAGE.**

⚠ WARNING**Follow EHS Policies!**

Failure to follow instructions below could result in death or serious injury.

- All Trane personnel must follow the company's Environmental, Health and Safety (EHS) policies when performing work such as hot work, electrical, fall protection, lockout/tagout, refrigerant handling, etc. Where local regulations are more stringent than these policies, those regulations supersede these policies.
- Non-Trane personnel should always follow local regulations.

⚠ WARNING**Cancer and Reproductive Harm!**

This product can expose you to chemicals including lead and bisphenol A (BPA), which are known to the State of California to cause cancer and birth defects or other reproductive harm. For more information go to www.P65Warnings.ca.gov.

⚠ WARNING**Refrigerant May Be Under Positive Pressure!**

Failure to follow instructions below could result in an explosion which could result in death or serious injury or equipment damage.

System contains refrigerant and may be under positive pressure; system may also contain oil. Recover refrigerant to relieve pressure before opening the system. See unit nameplate for refrigerant type. Do not use non-approved refrigerants, refrigerant substitutes, or non-approved refrigerant additives.

NOTICE**Equipment Damage!**

Mixing refrigerants or oils could result in equipment damage including bearing damage, introduction of acids into the chiller, or continuous purge pump-out in high-head/high ambient applications.

CenTraVac™ chillers are manufactured with different refrigerant/oil systems: 1) chillers using R-123 refrigerant and OIL00022 compressor oil, and 2) chillers using R-514A refrigerant and various Trane POE-based compressor oils.

Always verify proper refrigerant and oil for your chiller. Do NOT mix refrigerants and oils.

This *Installation, Operation, and Maintenance* manual applies to CenTraVac® chillers with two different refrigerant and compressor oil systems:

- R-123 refrigerant and OIL00022 compressor oil.
- R-514A refrigerant and Trane OIL00379/OIL00380 compressor oil.

NOTICE**Equipment Damage!**

Failure to follow instructions below could result in equipment damage.

Follow oil use instructions for post-service compressor air-run procedures.

For post-service compressor air-run procedures on CenTraVac chillers that use R-514A refrigerant and POE oil:

1. Use Trane OIL00381/OIL00382 compressor oil for the air-run procedure.
2. Upon completion of the air-run procedure, drain the OIL00381/OIL00382 from the sump.
3. After unit final assembly and evacuation, refill the sump with Trane OIL00379/OIL00380.

Important: Verify proper refrigerant and compressor oil for your chiller before proceeding!

NOTICE**Do Not Use Non-Compatible Parts or Materials!**

Use of non-compatible parts or materials could result in equipment damage.

Only genuine Trane® replacement components with identical Trane part numbers should be used in Trane CenTraVac chillers. Trane assumes no responsibility for damages resulting from the use of non-compatible parts or materials.

Factory Warranty Information

Compliance with the following is required to preserve the factory warranty:

All Unit Installations

Startup MUST be performed by Trane, or an authorized agent of Trane, to VALIDATE this WARRANTY. Contractor must provide a two-week startup notification to Trane (or an agent of Trane specifically authorized to perform startup).

Additional Requirements for Units Requiring Disassembly and Reassembly

When a new chiller is shipped and received from our Trane manufacturing location and, for any reason, it requires disassembly or partial disassembly, and reassembly—which could include but is not limited to the evaporator, condenser, control panel, compressor/motor, economizer, purge, factory-mounted starter or any other components originally attached to the fully assembled unit—compliance with the following is required to preserve the factory warranty:



Introduction

- Trane, or an agent of Trane specifically authorized to perform start-up and warranty of Trane® products, will perform or have direct on-site technical supervision of the disassembly and reassembly work.
- The installing contractor must notify Trane—or an agent of Trane specifically authorized to perform startup and warranty of Trane® products—two weeks in advance of the scheduled disassembly work to coordinate the disassembly and reassembly work.
- Start-up must be performed by Trane or an agent of Trane specifically authorized to perform startup and warranty of Trane® products.

Trane, or an agent of Trane specifically authorized to perform start-up and warranty of Trane® products, will provide qualified personnel and standard hand tools to perform the disassembly and reassembly work at a location specified by the contractor. The contractor shall provide the rigging equipment such as chain falls, gantries, cranes, forklifts, etc. necessary for the disassembly and reassembly work and the required qualified personnel to operate the necessary rigging equipment.

Product Safety Information

This appliance is not intended for use by persons (including children) with reduced physical, sensory or mental capabilities, or lack of experience and knowledge, unless they have been given supervision or instruction concerning use of the appliance by a person responsible for their safety. Children should be supervised to ensure that they do not play with the appliance.

Maximum altitude of use 3000 meters.

This appliance incorporates an earth connection for functional purposes only.

For installation only in locations not accessible to the general public.

CVHF Operating Limits

Table 1. CVHF water temperatures (°F)

Setpoint	Min	Max	Default
Chilled Water	0	90	44
Hot Water	80	140	130

Note: See UL nameplate on unit control panel. Condenser pressure shall not exceed X PSI where X is the three-digit number following “CDPR” and evaporator pressure shall not exceed Y PSI where Y is the three-digit number following “EVPR”.

Copyright

This document and the information in it are the property of Trane, and may not be used or reproduced in whole or in part without written permission. Trane reserves the right to revise this publication at any time, and to make changes to its content without obligation to notify any person of such revision or change.

Trademarks

All trademarks referenced in this document are the trademarks of their respective owners.

Factory Training

Factory training is available through Trane University™ to help you learn more about the operation and maintenance of your equipment. To learn about available training opportunities, contact Trane University™.

Online: www.trane.com/traneuniversity

Email: traneuniversity@trane.com

Revision History

- Updated figures in Control Panel and Module Installation topics in Installation: Controls chapter.
- Updated Standard field power wiring requirements table in Installation: Electrical chapter.
- Updated Standard customer-supplied remote field wiring requirements table in Customer-supplied Remote Starter Wiring chapter.
- Updated to UL60335-2-40.
- Added Operating Limits section to Introduction.



Table of Contents

Unit Nameplate	8	Waterbox Locations	35
Model Number Descriptions	9	Grooved Pipe Coupling	35
Pre-Installation	10	Flange-connection Adapters	36
ASHRAE Standard 15 Compliance	10	Victaulic Gasket Installation	36
Unit Shipment	10	Screw-Tightening Sequence for Water	
Installation Requirements and Contractor		Piping Connections	37
Responsibilities	10	Flanges with 4, 8, or 12 Screws	38
Storage Requirements	12	Flanges with 16, 20, or 24 Screws	38
Unit Components	13	Flanges with More than 24	
Dimensions and Weights	15	Screws	38
Recommended Unit Clearances	15	Evaporator Waterbox Covers	38
General Weights	16	Pressure Testing Waterside Piping	39
Weights (lb)	16	Eddy Current Testing	39
Weights (kg)	20	Vent Piping	40
Installation: Mechanical	25	Refrigerant Vent Line	40
Operating Environment	25	General Requirements	40
Foundation Requirements	25	Purge Discharge	40
Rigging	25	Vent Line Materials	40
Standard Chiller Lift	25	Vent Line Sizing	40
Special Lift Requirements	27	Vent Line Installation	41
Unit Isolation	27	Vent Line Sizing Reference	44
Isolation Pads	27	Insulation	47
Spring Isolators	27	Unit Insulation Requirements	47
Leveling the Unit	29	Insulation Thickness Requirements	47
Installation: Water Piping	30	Factory-applied Insulation	47
Overview	30	Installation: Controls	49
Water Treatment	30	Symbio™ 800	49
Water Pressure Gauges	30	AdaptiView™ Display	49
Valves – Drains and Vents	30	Tracer® TU	49
Strainers	31	Control Panel	50
Required Flow-Sensing Devices	31	Installing the Tracer AdaptiView	
Paddle Switches	31	Display	52
Water Flow Detection Controller and		Adjusting the Tracer® AdaptiView™	
Sensor	31	Display Arm	53
Evaporator and Condenser Water		Module Installation	53
Piping	33	Air-Fi®	53
Water Piping Connections	34	Wi-Fi	55
		Installation: Electrical	56
		Installation Requirements	56



Table of Contents

Electrical Requirements	56	Operating Principles	70
Trane-supplied Starter Wiring	57	General Requirements	70
Customer-supplied Remote Starter		Cooling Cycle	70
Wiring.....	58	CVHE and CVHG 3-Stage	
Current Transformer and Potential		Compressor	70
Transformer Wire Sizing	58	CVHF 2-Stage Compressor	70
Power Supply Wiring.....	60	Oil and Refrigerant Pump	71
Three-Phase Power.....	60	Compressor Lubrication System	71
Circuit Breakers and Fused		Motor Cooling System.....	74
Disconnects	60	Tracer® AdaptiView™ Display.....	74
Power Factor Correction Capacitors		Start-Up and Shutdown	75
(Optional).....	60	Sequence of Operation.....	75
Interconnecting Wiring	61	Software Operation Overview	
Starter to Motor Wiring (Remote-Mounted		Diagram	75
Starters Only)	62	Start-Up Sequence of Operation—	
Ground Wire Terminal Lugs.....	62	Wye-delta.....	76
Terminal Clamps	63	Power Up	80
Wire Terminal Lugs.....	63	Ice Building Control	80
Bus Bars	63	Free Cooling Cycle	82
Starter to Control Panel Wiring	64	Free Cooling (FRCL)	83
10 to 13.8kV Medium Voltage Motor	65	Hot Gas Bypass (HGBP)	83
Motor Terminal Box	65	Hot Water Control	83
Motor Supply Wiring	65	Heat Recovery Cycle.....	84
Motor Terminals.....	66	Auxiliary Condensers	84
Ground Wire Terminal Lug.....	66	Control Panel Devices and Unit-Mounted	
System Control Circuit Wiring (Field		Devices	84
Wiring).....	67	Unit Control Panel.....	84
Water Pump Interlock Circuits and Flow		User-defined Language Support	84
Switch Input	68	Unit Start-Up and Shutdown	
Chilled Water Pump	68	Procedures	85
Chilled Water Proof of Flow.....	68	Daily Unit Start-Up	85
Condenser Water Pump	68	Seasonal Unit Start-Up	86
Condenser Water Proof of Flow	68	Daily Unit Shutdown.....	86
Heat Recovery Proof of Flow	68	Seasonal Unit Shutdown	86
Temperature Sensor Circuits	69	Recommended Maintenance	87
CWR – Outdoor Option	69	Record Keeping Forms.....	87
Optional Control and Output		Normal Operation.....	87
Circuits	69	Recommended Compressor Oil	
Starter Module Configuration	69	Change	89
Schematic Wiring Drawings	69	Purge System	90

Leak Checking Based on Purge Pump Out Time	90	Torque Requirements and Waterbox Weights	95
Long Term Unit Storage	90	Connection Devices Information	96
Refrigerant Charge	91	Appendix A: Forms and Check Sheets	97
Leak Testing	91	Unit Start-Up/Commissioning	97
Recommended System Maintenance	91	Appendix B: Chiller Installation Completion and Request for Trane Service	98
Condenser	92	Appendix C: CenTraVac® Chiller Start-Up Tasks to be Performed by Trane	100
Evaporator	92	Appendix D: CenTraVac® Chiller Annual Inspection List	102
Waterbox and Tubesheet Protective Coatings	92	Appendix E: CenTraVac® Chiller Operator Log	103
Sacrificial Anodes	92		
Waterbox Removal and Installation	94		
Discussion	94		
Procedure	94		
Reassembly	95		



Unit Nameplate

The unit nameplate is located on the left side of the control panel. A typical unit nameplate contains the following information:

- Unit Model and Size Descriptor
- Unit Electrical Requirements
- Correct Operating Charge and Refrigerant Type
- Unit Test Pressures and Maximum Operating Pressures
- Unit Literature

Serial Number — The unit serial number provides the specific chiller identity. Always provide this serial number when calling for service or during parts identification.

Service Model Number — The service model represents the unit as built for service purposes. It identifies the selections of variable unit features required when ordering replacements parts or requesting service.

Note: *Unit-mounted starters are identified by a separate number found on the starter.*

Product Description Block — The CenTraVac® chiller models are defined and built using the Product Definition and Selection (PDS) system. This system describes the product offerings using a product coding block which is made up of feature categories and codes that identify all characteristics of a unit.



Model Number Descriptions

Digit 1, 2, 3 — Unit Function	Digit 32 — Auxiliary Condenser Tubes
Digit 4 — Development Sequence	Digit 33 — Orifice Size
Digit 5, 6, 7 — Nominal Tonnage	Digit 34 — Orifice Size
Digit 8 — Unit Voltage	Digit 35 — Unit Option: Insulation and RuptureGuard™
Digit 9 — Unit Type	Digit 36 — Enhanced Protection
Digit 10, 11 — Design Sequence	Digit 37 — Generic BAS
Digit 12 — Hot Gas Bypass	Digit 38 — Extended Operation
Digit 13 — Starter Type	Digit 39 — Tracer® Communication Interface
Digit 14 — Control Enclosure	Digit 40 — Condenser Refrigerant Control
Digit 15 — Compressor Motor Power (CPKW)	Digit 41 — Manufacturing Location
Digit 16, 17, 18 — Compressor Impeller Cutback	Digit 42 — Special Option
Digit 19 — Evaporator Shell Size	Digit 43 — Water Flow Control
Digit 20 — Evaporator Tube Bundle (Nominal Tons)	Digit 44 — Chilled Water Reset
Digit 21 — Evaporator Tubes	Digit 45 — Heat Recovery Temperature Sensors
Digit 22 — Evaporator Waterbox	Digit 46 — Gas Powered Chiller
Digit 23 — Condenser Shell Size	Digit 47 — Compressor Motor Frame Size
Digit 24 — Condenser Tube Bundle (Nominal Tons)	Digit 48 — Volute Discharge Angle
Digit 25 — Condenser Tubes	Digit 49 — Operating Status
Digit 26 — Condenser Waterbox	Digit 50 — Industrial Chiller Package
Digit 27 — Heat Recovery Condenser Shell Size	Digit 51 — Control Power Transformer
Digit 28 — Heat Recovery Condenser Tube Bundle (Nominal Tons)	Digit 52 — Motor and Terminal Board Configuration
Digit 29 — Heat Recovery Tubes	Digit 53 — Thermal Dispersion Water Flow Proving
Digit 30 — Heat Recovery Condenser Waterbox	
Digit 31 — Auxiliary Condenser Size and Waterbox	



Pre-Installation

ASHRAE Standard 15 Compliance

Trane recommends that indoor CenTraVac® chiller installations fully meet or exceed the guidelines of the current version of ASHRAE® Standard 15, in addition to any applicable national, state, or local requirements. This typically includes:

- A refrigerant monitor or detector that is capable of monitoring and alarming within the acceptable exposure level of the refrigerant, and that can actuate mechanical ventilation.
- Audible and visual alarms, activated by the refrigerant monitor, inside the equipment room and outside of every entrance.
- The equipment room should be properly vented to the outdoors, using mechanical ventilation that can be activated by the refrigerant monitor.
- The purge discharge and the rupture disk must be properly piped to the outdoors.
- If required by local or other codes, a self-contained breathing apparatus should be available in close proximity to the equipment room.

Refer to the latest copy of ASHRAE Standard 15 for specific guidelines. Trane assumes no responsibility for any economic, health, or environmental issues that may result from an equipment room's design or function.

Unit Shipment

Inspect unit while it is still on the truck for any shipping damage. The chiller ships shrink-wrapped in a 0.010-inch (0.254 mm) recyclable film protective covering. Do NOT remove shrink-wrap for inspection! Inspect for damage to the shrink-wrap and determine if physical damage has occurred.

Each chiller ships from the factory as a hermetically assembled package; it is factory-assembled, -wired, and -tested. All openings except for the waterbox vent and drain holes are covered or plugged to prevent contamination during shipment and handling. "Unit Components," p. 13 shows an illustration of a typical unit and its components. As soon as the unit arrives at the job site, inspect it thoroughly for damage and material shortages. If the unit is damaged, contact your sales office immediately for further instructions. In addition:

1. Verify the hermetic integrity of the unit by checking the chiller pressure for an indication of holding charge pressure.
2. To prevent damaging moisture from entering the unit and causing corrosion, each chiller is pressurized with 3 to 5 psig (20.7 to 34.5 kPaG) of dry nitrogen before shipment.

Note: The holding charge should register approximately 5 psig (34.5 kPaG) at 72°F (22.2°C). Place a gauge on the access valve provided (indicated by arrow and circle in the following figure) on the refrigerant pump discharge line to verify the holding charge. If the charge has escaped, contact your local Trane sales office for instructions.

3. The loose parts box and isolator pads ship on top of the control panel box.
4. Check the oil sump sight glasses to verify that the sump was factory-charged with 9 gallons (34.1 L) of oil. If no oil level is visible, contact your local Trane sales office.

Important: If isolation springs are installed, do NOT block oil tank serviceability.

Figure 1. Refrigerant pump discharge line access valve

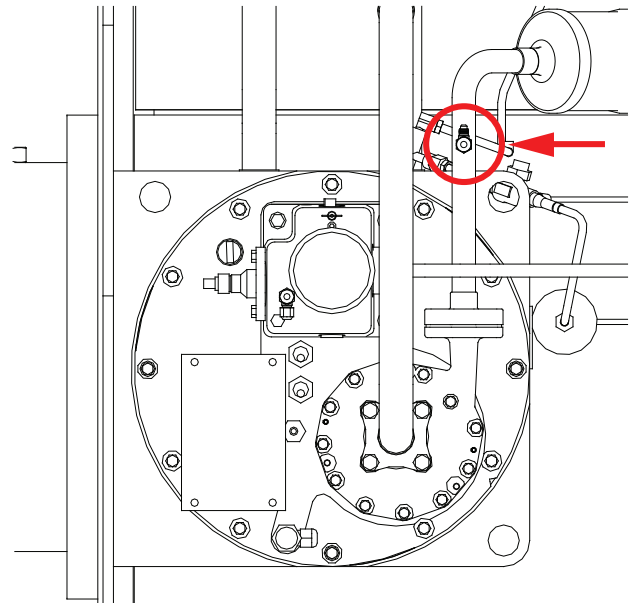

Installation Requirements and Contractor Responsibilities

A list of the contractor responsibilities typically associated with the unit installation process is provided in the following table.

⚠ WARNING
Combustible Material!
Failure to follow instructions below could result in death, serious injury, or equipment damage. Shrink-wrap is a combustible material. Avoid open flames and hot sparks.

Note: The chiller should remain within its protective shrink-wrap covering during storage.

Table 2. Installation requirements

Type of Requirement	Trane Supplied Trane Installed	Trane Supplied Field Installed	Field Supplied Field Installed
Foundation	—	—	<ul style="list-style-type: none"> Meet foundation requirements
Rigging	—	—	<ul style="list-style-type: none"> Safety chains Rigging shackles Lifting beam
Disassembly/Reassembly (as required)	<ul style="list-style-type: none"> Trane will perform or have direct on-site supervision of the disassembly and reassembly work (contact your local Trane office for pricing) 	—	—
Isolation	—	<ul style="list-style-type: none"> Isolation pads or spring isolators 	<ul style="list-style-type: none"> Isolation pads or spring isolators Optional spring isolators, when required, are installed by others; do NOT overload springs and do NOT install isolation springs if they block serviceable parts such as the oil tank system, service valves, etc.
Electrical	<ul style="list-style-type: none"> Circuit breakers or fusible disconnects (optional) Unit-mounted starter (optional) Power factor correction capacitors (PFCCs) (optional) 	<ul style="list-style-type: none"> Jumper bars Temperature sensor (optional outdoor air) Flow switches (may be field supplied); for installation instructions for the ifm efector® flow detection controller and sensor, refer to “Water Flow Detection Controller and Sensor,” p. 31 or Trane literature that shipped with the device Remote-mounted starter (optional) Air-Fi® wireless communication (optional) Wi-Fi wireless communication (optional) 	<ul style="list-style-type: none"> Circuit breakers or fusible disconnects (optional) Electrical connections to unit-mounted starter (optional) Electrical connections to remote-mounted starter (optional) Wiring sizes per submittal and National Electric Code (NEC) PFCCs (remote mounted starter optional only) Terminal lugs Ground connection(s) Jumper bars BAS wiring (optional) Inter-processor communication (IPC) wiring (AFD and remote-mounted starters only) Control voltage wiring (AFD and remote-mounted starters only) Oil pump interlock wiring (AFD and remote mounted starters only) High condenser pressure interlock wiring (AFD and remote-mounted starters only) Chilled water pump contactor and wiring including interlock Condenser water pump contactor and wiring including interlock Option relays and wiring Symbio 800 BAS communication wiring (optional)
Water piping	—	<ul style="list-style-type: none"> Flow sensing devices (may be field supplied) 	<ul style="list-style-type: none"> Taps for flow sensing devices Taps for thermometers and gauges Thermometers Strainers (as required) Water flow pressure gauges Isolation and balancing valves in water piping Vents and drain on waterbox valves (one each per pass) Pressure relief valves (for waterboxes as required)
Relief	<ul style="list-style-type: none"> Rupture disk assembly 	<ul style="list-style-type: none"> RuptureGuard™ (optional); refer to <i>RuptureGuard™ Pressure Relief System Option For Use with Water-Cooled CenTraVac® Chillers Installation, Operation, and Maintenance</i> (CTV-SVX06*-EN) 	<ul style="list-style-type: none"> Vent line and flexible connector and vent line from rupture disk to atmosphere

Pre-Installation

Table 2. Installation requirements (continued)

Type of Requirement	Trane Supplied Trane Installed	Trane Supplied Field Installed	Field Supplied Field Installed
Insulation	<ul style="list-style-type: none"> Insulation (optional) 	—	<ul style="list-style-type: none"> Insulation Chiller feet insulation
Water Piping Connection Components	Flanged (optional) <ul style="list-style-type: none"> Welded on flange for 300 psig (2068.4 kPaG) waterboxes 	Flanged (optional) <ul style="list-style-type: none"> Victaulic® to flange adapter for 150 psig (1034.2 kPaG) waterboxes 	Victaulic® <ul style="list-style-type: none"> Victaulic® coupling for 150 psig (1034.2 kPaG) and 300 psig (2068.4 kPaG) waterboxes Fasteners for flanged-type connections (optional)
Other Materials	—	—	<ul style="list-style-type: none"> Trace gas (1 lb [0.45 kg] maximum per machine as needed to perform leak testing) Material and equipment to perform leak testing Dry nitrogen (8 psig [55.2 kPaG] maximum per machine as needed)
"Appendix B: Chiller Installation Completion and Request for Trane Service," p. 98 (CTV-ADF001*-EN; refer to "Appendix A: Forms and Check Sheets," p. 97)	—	—	<ul style="list-style-type: none"> To be completed by installing contractor prior to contacting Trane for start-up
Chiller start-up commissioning ^(a)	<ul style="list-style-type: none"> Trane, or an agent of Trane specifically authorized to perform start-up of Trane® products 	—	—
Post-commissioning transport of empty refrigerant containers for return or recycling	—	—	<ul style="list-style-type: none"> Move empty refrigerant containers to an easily accessible point of loading

^(a) Start-up must be performed by Trane or an agent of Trane specifically authorized to perform start-up and warranty of Trane® products. Contractor shall provide Trane (or an agent of Trane specifically authorized to perform start-up) with notice of the scheduled start-up at least two weeks prior to the scheduled start-up.

Storage Requirements

Note: *If the chiller is stored outdoors for any amount of time, do NOT remove ANY shipping coverings. Protect the chiller from the elements and protect against freezing, especially if any shipping materials have been removed.*

NOTICE

Equipment Damage!

Failure to protect the unit from freezing could result in equipment damage.

If fluid has been added to the piping, the unit must be protected from freezing. Freeze damage from an unheated equipment room is not the Trane company's responsibility. These are indoor units.

NOTICE

Insulation Damage!

Failure to follow these instructions could result in insulation damage.

To prevent damage to factory installed insulation:

- Do not allow the insulation to be exposed to excessive sunlight. Store indoors or cover with canvas to prevent exposure.
- Do not use thinners and solvents or other types of paint. Use only water base latex.

Table 3. Storage requirements

Less than 1 month	1 to 6 months	Greater than 6 months
Location requirements: <ul style="list-style-type: none"> Solid foundation Vibration free Dry Temperature range -40°F to 158°F (-40°C to 70°C) 	Location requirements: <ul style="list-style-type: none"> Solid foundation Vibration free Dry Temperature range -40°F to 158°F (-40°C to 70°C) 	Location requirements: <ul style="list-style-type: none"> Solid foundation Vibration free Dry Temperature range -40°F to 158°F (-40°C to 70°C)
<ul style="list-style-type: none"> Do not remove any plastic coverings 	<ul style="list-style-type: none"> Do not remove any plastic coverings 	<ul style="list-style-type: none"> Do not remove any plastic coverings
<ul style="list-style-type: none"> Do not charge the chiller with refrigerant If additional refrigerant is on site, follow manufacturer storage requirements 	<ul style="list-style-type: none"> Do not charge the chiller with refrigerant If additional refrigerant is on site, follow manufacturer storage requirements 	<ul style="list-style-type: none"> Do not charge the chiller with refrigerant If additional refrigerant is on site, follow manufacturer storage requirements

Table 3. Storage requirements (continued)

Less than 1 month	1 to 6 months	Greater than 6 months
<ul style="list-style-type: none"> Verify dry nitrogen pressure using gauge located on the evaporator shell reads 3 to 5 psig (20.7 to 34.5 kPaG) Notify the local Trane office if charge has escaped 	<ul style="list-style-type: none"> Verify dry nitrogen pressure using gauge located on the evaporator shell reads 3 to 5 psig (20.7 to 34.5 kPaG) Notify the local Trane office if charge has escaped 	<ul style="list-style-type: none"> Verify dry nitrogen pressure using gauge located on the evaporator shell reads 3 to 5 psig (20.7 to 34.5 kPaG) Notify the local Trane office if charge has escaped
<ul style="list-style-type: none"> Do not operate purge unit 	<ul style="list-style-type: none"> Do not operate purge unit 	<ul style="list-style-type: none"> Do not operate purge unit
<p style="text-align: center;">—</p>	<ul style="list-style-type: none"> Verify waterbox and tube bundles are clean and dry 	<ul style="list-style-type: none"> Verify waterbox and tube bundles are clean and dry
<p style="text-align: center;">—</p>	<p style="text-align: center;">—</p>	<ul style="list-style-type: none"> Conduct an oil analysis and verify no oil breakdown^(a) Repeat yearly Replace oil if breakdown has occurred If no oil analysis program has been followed, replace oil prior to start-up
<p style="text-align: center;">—</p>	<p style="text-align: center;">—</p>	<ul style="list-style-type: none"> Every six months, check unit pressure or vacuum and take note of changes that could indicate a leak; contact your local Trane office if any leaks occur Every six months, start the oil pump and rotate compressor shaft about 450° to prevent potential bearing issues^(a); contact your local Trane Service Agency to perform this task If the chiller will be stored for more than six months after production, contact your local Trane Service Agency for <i>required</i> extended storage actions to minimize impact to the chiller and preserve the warranty. Chillers stored five years or longer should be inspected for leaks every five years by a qualified service organization

^(a) If the chiller will be stored for more than six months after production, contact your local Trane Service Agency for *required* extended storage actions to minimize impact to the chiller and preserve the warranty.

Unit Components

Note: The control panel side of the unit is always designated as the front side of the unit.

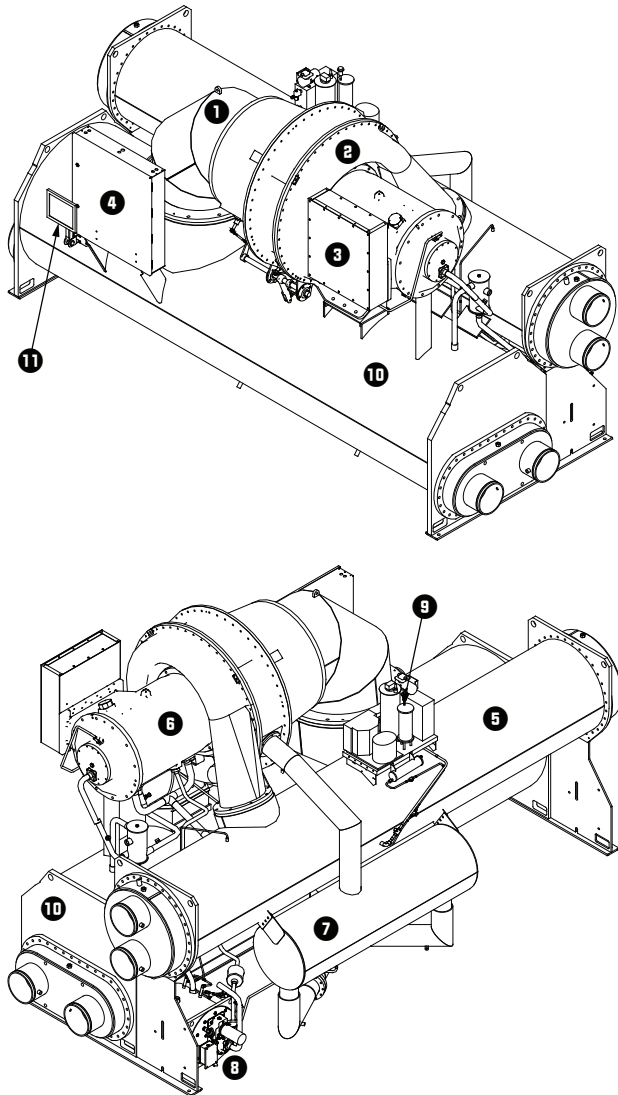
Figure 2. Typical CVHF CenTraVac® chiller

1. Suction Elbow
2. Compressor
3. Terminal Box
4. Control Panel
5. Condenser
6. Motor Housing
7. Economizer
8. Oil Tank Assembly
9. Purge
10. Evaporator
11. Display Panel



Dimensions and Weights

Important: For units sold in the United States, field provisions shall be made to ensure the unit is in compliance with NEC/NFPA70 when the disconnect height exceeds 2 meters.

Recommended Unit Clearances

Adequate clearances around and above the chiller are required to allow sufficient access for service and maintenance operations. Specific unit clearance requirements are indicated in the submittal package provided for your unit.

- Do NOT install piping or conduit above the compressor motor assembly or behind the suction elbow of the unit.
- Minimum vertical clearance above the unit is 3 feet (92 cm).
- Use a housekeeping pad to provide better service clearances; refer to submittal for more information.

Per National Electric Code (NEC) Article 110: Unit mounted starters from 0 to 600V require a 42-inch (107 cm) clearance, 601 to 2500V require a 48-inch (122 cm) clearance, and 2501 to 9000V require a 60-inch (152 cm) clearance. Refer to NEC and local electrical codes for starter and control panel clearance requirements.

Figure 3. Clearance requirements

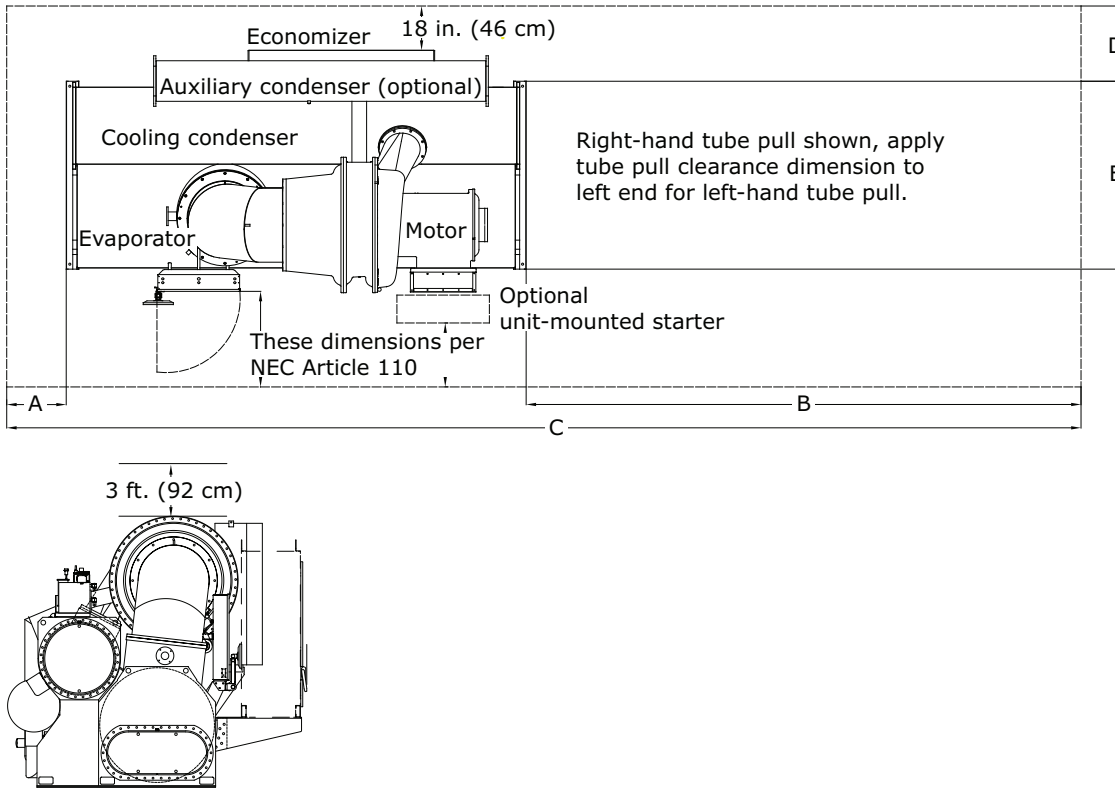

Table 4. Clearance requirements

Evaporator Size	Shell Combo	A		B		C		D		E	
		in.	cm	in.	cm	in.	cm	in.	cm	in.	cm
032 Short/Long	Short/Short	45	114	141	358	321	815	34	86	53	134
	Short/Long	77	195	219	556	431	1094	34	86	53	134
	Long/Long	45	114	187	474	411	1043	34	86	53	134
050 Short/Long	Short/Short	45	114	141	358	321	815	40	101	62	157
	Short/Long	78	198	219	556	431	1094	40	101	62	157
	Long/Long	45	114	187	474	411	1043	40	101	62	157



Dimensions and Weights

Table 4. Clearance requirements (continued)

Evaporator Size	Shell Combo	A		B		C		D		E	
		in.	cm	in.	cm	in.	cm	in.	cm	in.	cm
080 Short/Long	Short/Short	53	134	141	358	329	835	36	91	76	193
	Short/Long	85	215	219	556	439	1115	36	91	76	193
	Long/Long	53	134	187	474	419	1064	36	91	76	193
142 Medium/Long/ Extended 210 Long	Medium/Long	78	198	207	525	444	1127	44	111	92	233
	Long/Long	58	147	187	474	424	1076	44	111	92	233
	Extended/Long	58	147	209	530	469	1191	44	111	92	233
	Long/Long	59	149	187	474	426	1082	47	119	102	259
250 Extended	Extended/Long	63	160	209	530	475	1206	43	109	115	292

Note: All dimensions are approximate; refer to the unit submittal package for exact dimensions for your unit.

General Weights

Weights (lb)

Important: The weight information provided here should be used for general information only. Trane does not recommend using this weight information for considerations relative to chiller handling, rigging, or placement. The large number of variances between chiller selections drives variances in chiller weights that are not recognized in these tables. For specific weights for your chiller, refer to your submittal package.

Table 5. Representative weights, 60 Hz chillers (lb)

Model	Comp Size	CPKW	Evap Size	Cond Size	Weights without Starters		Weights with Starters	
	NTON		EVSZ	CDSZ	Operating	Shipping	Operating	Shipping
CVHE	230-320	233	032S	032S	14828	13469	—	—
		289			—	—	16508	15149
	230-320	289	032S	032L	15433	13924	17113	15604
	230-320	289	032L	032L	16277	14574	17957	16254
	230-320	289	050S	050S	20035	17599	21715	19279
	230-320	289	050S	050L	21001	18356	22681	20036
	230-320	289	050L	050L	22352	19304	24032	20984
	360-500	455	050S	050S	20717	18281	22397	19961
	360-500	455	050S	050L	21683	19038	23363	20718
	360-500	455	050L	050L	23034	19986	24714	21666
	360-500	455	050S	080S	23200	20265	24880	21945
	360-500	455	050L	080L	26793	22976	28473	24656
	360-500	455	080S	080S	29854	25634	31534	27314
	360-500	455	080S	080L	31442	26917	33122	28597
	360-500	455	080L	080L	33463	28333	35143	30013



Dimensions and Weights

Table 5. Representative weights, 60 Hz chillers (lb) (continued)

Model	Comp Size	CPKW	Evap Size	Cond Size	Weights without Starters		Weights with Starters	
	NTON		EVSZ	CDSZ	Operating	Shipping	Operating	Shipping
CVHF	350-570	588	050S	050S	20487	17984	22167	19664
	350-570	588	050S	050L	21453	18741	23133	20421
	350-570	588	050L	050L	22703	19567	24383	21247
	350-570	588	050S	080S	22970	19968	24650	21648
	350-570	588	050L	080L	26512	22557	28192	24237
	350-570	588	080S	080S	31845	26997	32173	27715
	350-570	588	080S	080L	32131	27318	33811	28998
	350-570	588	080L	080L	34319	28855	35999	30535
	350-910	957	080S	080S	32843	28385	35843	31385
	350-910	957	080S	080L	34481	29668	37481	32668
	350-910	957	080L	080L	36669	31205	39669	34205
	350-910	957	080L	142L	44814	37663	47814	40663
	350-910	957	142M	142L	48446	40540	51446	43540
	350-910	957	142L	142L	49667	41453	52667	44453
	1070-1300	1062	080L	142L	45710	38559	48710	41559
	1070-1300	1062	142M	142L	49116	41210	52116	44210
	1070-1300	1062	142L	142L	50337	42123	53337	45123
	1070-1300	1062	142E	142L	51762	43109	54762	46109
	1070-1300	1062	142M	210L	55062	46057	58062	49057
	1070-1300	1062	142L	210L	56333	46970	59333	49970
	1070-1300	1062	142E	210L	57758	47956	60758	50956
	1070-1300	1062	210L	210L	61899	51929	64899	54929
	1070-1300	1062	250E	250L	76152	63330	79152	66330
	1470	1340	210L	210L	64550	54580	67550	57580
1470-1720	1340	142L	210L	58984	49621	61984	52621	
1470-1720	1340	250E	250L	78803	65981	81803	68981	

Notes:

1. TECU tubes, 0.028 in. tube wall thickness.
2. 300 psig marine waterboxes.
3. Heaviest possible bundle and motor combination.
4. Operating weights assume the largest possible refrigerant charge.
5. Weights with starters assume the heaviest possible starter (AFD when it's an allowed option).
6. Industrial Control Panel (INDP) option, add 50 lb.
7. Control Power Transformer (CPTR) option, add 130 lb.
8. Supplemental Motor Protection (SMP) option, add 500 lb.

Table 6. Representative weights, 50 Hz chillers (lb)

Model	Comp Size	CPKW	Evap Size	Cond Size	Weights without Starters		Weights with Starters	
	NTON		EVSZ	CDSZ	Operating	Shipping	Operating	Shipping
CVHE	190-320	215	032S	032S	14785	13426	—	—
		231			—	—	16456	15097
	190-320	215	032S	032L	15390	13881	—	—
		231			—	—	17061	15552
	190-320	215	032L	032L	16234	14531	—	—
		231			—	—	17905	16202
	190-320	215	050S	050S	19696	17195	—	—
		231			—	—	21419	18918
	190-320	215	050S	050L	20712	17952	—	—
		231			—	—	22435	19675
	190-320	215	050L	050L	21829	18682	—	—
		231			—	—	23636	20502
	300-500	360	050S	050S	21307	18806	—	—
		379			—	—	22608	20107
	300-500	360	050S	050L	22323	19563	—	—
		379			—	—	23624	20864
	300-500	360	050L	050L	23524	20390	—	—
		379			—	—	24825	21691
	300-500	360	050S	080S	24923	21589	—	—
		379			—	—	26224	22890
300-500	360	080S	080S	30740	26520	—	—	
	379			—	—	32041	27821	
300-500	360	080S	080L	32328	27803	—	—	
	379			—	—	33629	29104	
300-500	360	080L	080L	34349	29219	—	—	
	379			—	—	35650	30520	



Dimensions and Weights

Table 6. Representative weights, 50 Hz chillers (lb) (continued)

Model	Comp Size	CPKW	Evap Size	Cond Size	Weights without Starters		Weights with Starters	
	NTON		EVSZ	CDSZ	Operating	Shipping	Operating	Shipping
CVHG	480-565	489	050S	050S	22258	19747	22815	20304
	480-565	489	050S	050L	23274	20504	23831	21061
	480-565	489	050L	050L	24391	21244	24948	21801
	480-565	489	050S	080S	25874	22538	26431	23095
	480-565	489	050L	080L	28712	24647	29269	25204
	480-565	489	080S	080L	33279	28754	33836	29311
	670-780	621	080S	080S	32952	28732	33509	29289
	670-780	621	080S	080L	34540	30015	35097	30572
	670-780	621	080L	080L	36561	31431	37118	31988
	670-780	621	080L	142L	45020	38203	45577	38760
	670-780	621	142M	142L	49518	41562	50075	42119
	670-780	621	142L	142L	50789	42475	51346	43032
	920-1100	621	080L	142L	46086	39269	46643	39826
	920-1100	892	142M	142L	50988	43032	51545	43589
	920-1100	892	142L	142L	52259	43945	52816	44502
	920-1100	892	142M	210L	56984	47879	57541	48436
	920-1100	892	142L	210L	58205	48792	58762	49349
	920-1100	892	142E	210L	59630	49778	60187	50335
	920-1100	892	210L	210L	63821	53751	64378	54308

Notes:

1. TECU tubes, 0.028 in. tube wall thickness.
2. 300 psig marine waterboxes.
3. Heaviest possible bundle and motor combination.
4. Operating weights assume the largest possible refrigerant charge.
5. Weights with starters assume the heaviest possible starter (AFD when it's an allowed option).
6. Industrial Control Panel (INDP) option, add 50 lb.
7. Control Power Transformer (CPTR) option, add 130 lb.
8. Supplemental Motor Protection (SMP) option, add 500 lb.

Weights (kg)

Important: The weight information provided here should be used for general information only. Trane does not recommend using this weight information for considerations relative to chiller handling, rigging, or placement. The large number of variances between chiller selections drives variances in chiller weights that are not recognized in these tables. For specific weights for your chiller, refer to your submittal package.

Table 7. Representative weights, 60 Hz chillers (kg)

Model	Comp Size	CPKW	Evap Size	Cond Size	Weights without Starters		Weights with Starters	
	NTON		EVSZ	CDSZ	Operating	Shipping	Operating	Shipping
CVHE	230-320	233	032S	032S	6726	6109	—	—
		289			—	—	7488	6871
	230-320	289	032S	032L	7000	6316	7762	7078
	230-320	289	032L	032L	7383	6611	8145	7373
	230-320	289	050S	050S	9088	7983	9850	8745
	230-320	289	050S	050L	9526	8326	10288	9088
	230-320	289	050L	050L	10139	8756	10901	9518
	360-500	455	050S	050S	9397	8292	10159	9054
	360-500	455	050S	050L	9835	8635	10597	9398
	360-500	455	050L	050L	10448	9065	11210	9828
	360-500	455	050S	080S	10523	9192	11285	9954
	360-500	455	050L	080L	12153	10422	12915	11184
	360-500	455	080S	080S	13542	11627	14304	12389
	360-500	455	080S	080L	14262	12209	15024	12971
	360-500	455	080L	080L	15179	12852	15941	13614



Dimensions and Weights

Table 7. Representative weights, 60 Hz chillers (kg) (continued)

Model	Comp Size	CPKW	Evap Size	Cond Size	Weights without Starters		Weights with Starters	
	NTON		EVSZ	CDSZ	Operating	Shipping	Operating	Shipping
CVHF	350-570	588	050S	050S	9293	8157	10055	8919
	350-570	588	050S	050L	9731	8501	10493	9263
	350-570	588	050L	050L	10298	8875	11060	9637
	350-570	588	050S	080S	10419	9057	11181	9819
	350-570	588	050L	080L	12026	10232	12788	10994
	350-570	588	080S	080S	14445	12246	14593	12571
	350-570	588	080S	080L	14574	12391	15336	13153
	350-570	588	080L	080L	15567	13088	16329	13850
	350-910	957	080S	080S	14897	12875	16258	14236
	350-910	957	080S	080L	15640	13457	17001	14818
	350-910	957	080L	080L	16633	14154	17994	15515
	350-910	957	080L	142L	20327	17084	21688	18444
	350-910	957	142M	142L	21975	18389	23336	19749
	350-910	957	142L	142L	22529	18803	23889	20164
	1070-1300	1062	080L	142L	20734	17490	22094	18851
	1070-1300	1062	142M	142L	22279	18693	23639	20053
	1070-1300	1062	142L	142L	22832	19107	24193	20467
	1070-1300	1062	142E	142L	23479	19554	24840	20915
	1070-1300	1062	142M	210L	24976	20891	26336	22252
	1070-1300	1062	142L	210L	25552	21305	26913	22666
	1070-1300	1062	142E	210L	26199	21752	27559	23113
	1070-1300	1062	210L	210L	28077	23555	29438	24915
	1070-1300	1062	250E	250L	34542	28726	35903	30087
	1470	1340	210L	210L	29279	24757	30640	26118
1470-1720	1340	142L	210L	26755	22508	28115	23868	
1470-1720	1340	250E	250L	35744	29928	37105	31289	

Notes:

1. TECU tubes, 0.71 mm tube wall thickness.
2. 2068.4 kPaG non-marine waterboxes.
3. Heaviest possible bundle and motor combination.
4. Operating weights assume the largest possible refrigerant charge.
5. Weights with starters assume the heaviest possible starter (AFD when it's an allowed option).
6. Industrial Control Panel (INDP) option, add 23 kg.
7. Control Power Transformer (CPTR) option, add 59 kg.
8. Supplemental Motor Protection (SMP) option, add 227 kg.

Table 8. Weights, 50 Hz chillers (kg)

Model	Comp Size	CPKW	Evap Size	Cond Size	Weights without Starters		Weights with Starters	
	NTON		EVSZ	CDSZ	Operating	Shipping	Operating	Shipping
CVHE	190-320	215	032S	032S	6706	6090	—	—
		231			—	—	7464	6848
	190-320	215	032S	032L	6981	6296	—	—
		231			—	—	7739	7054
	190-320	215	032L	032L	7364	6591	—	—
		231			—	—	8122	7349
	190-320	215	050S	050S	8934	7800	—	—
		231			—	—	9715	8581
	190-320	215	050S	050L	9395	8143	—	—
		231			—	—	10176	8924
	190-320	215	050L	050L	9901	8474	—	—
		231			—	—	10721	9300
	300-500	360	050S	050S	9665	8530	—	—
		379			—	—	10255	9120
	300-500	360	050S	050L	10126	8874	—	—
		379			—	—	10716	9464
	300-500	360	050L	050L	10670	9249	—	—
		379			—	—	11260	9839
	300-500	360	050S	080S	11305	9793	—	—
		379			—	—	11895	10383
300-500	360	080S	080S	13943	12029	—	—	
	379			—	—	14534	12619	
300-500	360	080S	080L	14664	12611	—	—	
	379			—	—	15254	13201	
300-500	360	080L	080L	15580	13254	—	—	
	379			—	—	16171	13844	



Dimensions and Weights

Table 8. Weights, 50 Hz chillers (kg) (continued)

Model	Comp Size	CPKW	Evap Size	Cond Size	Weights without Starters		Weights with Starters	
	NTON		EVSZ	CDSZ	Operating	Shipping	Operating	Shipping
CVHG	480-565	489	050S	050S	10096	8957	10349	9210
	480-565	489	050S	050L	10557	9300	10810	9553
	480-565	489	050L	050L	11064	9636	11316	9889
	480-565	489	050S	080S	11736	10223	11989	10476
	480-565	489	050L	080L	13024	11180	13276	11432
	480-565	489	080S	080L	15095	13043	15348	13295
	670-780	621	080S	080S	14947	13033	15199	13285
	670-780	621	080S	080L	15667	13615	15920	13867
	670-780	621	080L	080L	16584	14257	16836	14510
	670-780	621	080L	142L	20421	17329	20673	17581
	670-780	621	142M	142L	22461	18852	22714	19105
	670-780	621	142L	142L	23038	19266	23290	19519
	920-1100	621	080L	142L	20904	17812	21157	18065
	920-1100	892	142M	142L	23128	19519	23380	19772
	920-1100	892	142L	142L	23704	19933	23957	20186
	920-1100	892	142M	210L	25848	21718	26100	21970
	920-1100	892	142L	210L	26401	22132	26654	22384
	920-1100	892	142E	210L	27048	22579	27300	22832
	920-1100	892	210L	210L	28949	24381	29201	24634

Notes:

1. TECU tubes, 0.71 mm tube wall thickness.
2. 2068.4 kPaG non-marine waterboxes.
3. Heaviest possible bundle and motor combination.
4. Operating weights assume the largest possible refrigerant charge.
5. Weights with starters assume the heaviest possible starter (AFD when it's an allowed option).
6. Industrial Control Panel (INDP) option, add 23 kg.
7. Control Power Transformer (CPTR) option, add 59 kg.
8. Supplemental Motor Protection (SMP) option, add 227 kg.



Installation: Mechanical

Operating Environment

Important:

- The standard chiller is designed for **INDOOR USE ONLY** and as such has NEMA Type 1 enclosures.
- For chillers in unheated equipment rooms, contact your local Trane Service Agency for methods to ensure that the oil temperature is maintained suitable for proper operation of the chiller.

NOTICE

Equipment Damage!

Failure to protect the unit from freezing could result in equipment damage.

If fluid has been added to the piping, the unit must be protected from freezing. Freeze damage from an unheated equipment room is not the Trane company's responsibility. These are indoor units.

NOTICE

Equipment Failure!

Unit operating at ambient temperatures exceeding 104°F (40°C) could result in AFD/starter component damage due to the panel's inability to dissipate heat adequately. Units operating at these temperatures could also fatigue the rupture disk, causing it to break at a reduced refrigerant pressure (<15 psig (<103.4 kPaG)).

If this adverse operating condition is present, take necessary action to improve the equipment room environment.

To ensure that electrical components operate properly, do NOT locate the chiller in an area exposed to dust, dirt, corrosive fumes, or excessive heat and humidity. The maximum ambient temperature for chiller operation is 104°F (40°C).

Foundation Requirements

Chiller mounting surface must be:

- Rigid non-warping mounting pads or a concrete foundation, and
- Able to support the chiller at its full operating weight (including completed piping and full operating charges of refrigerant, oil, and water).

For proper unit operation, the chiller must be level within 1/16-inch (1.6 mm) over its length and width when set into place on the mounting surface. See "Leveling the Unit," p. 29 for more information. For approximate weights for various chiller sizes and options in pounds and kilograms, see "Weights (lb)," p. 16 and "Weights (kg)," p. 20, respectively.

Note: For specific weight information, refer to the unit submittal package.

Important: Trane will not assume responsibility for equipment problems resulting from an improperly designed or constructed foundation.

Rigging

Lifting is the recommended method for moving chillers. Suggested lifting arrangements for standard units are described in "Standard Chiller Lift," p. 25.

Note: The lifting beam used for CVHE, CVHF, and CVHG CenTraVac® chillers must be at least 16 ft. (4.9 m) long.

⚠ WARNING

Heavy Object!

Failure to follow instructions below could result in unit dropping which could result in death or serious injury, and equipment or property-only damage. Ensure that all the lifting equipment used is properly rated for the weight of the unit being lifted. Each of the cables (chains or slings), hooks, and shackles used to lift the unit must be capable of supporting the entire weight of the unit. Lifting cables (chains or slings) may not be of the same length. Adjust as necessary for even unit lift.

⚠ WARNING

Improper Unit Lift!

Failure to properly lift unit in a LEVEL position could result in unit dropping and possibly crushing operator/technician which could result in death or serious injury, and equipment or property-only damage. Test lift unit approximately 24 inches (61 cm) to verify proper center of gravity lift point. To avoid dropping of unit, reposition lifting point if unit is not level.

NOTICE

Wiring Damage!

Damage to unit wiring could result in equipment failure. Care must be taken during rigging, assembly and disassembly to avoid damaging unit wiring.

Standard Chiller Lift

1. Insert rigging shackles at the points indicated in the following figure. A 2-inch (50.8 mm) 1.25-inch (31.8 mm) diameter lifting hole is provided at each of these points.
2. Attach the lifting chains or cables.

Installation: Mechanical

3. After the lifting cables are in place, attach a safety chain or cable between the first-stage casing of the compressor and the lifting beam.

Important: There should NOT be tension on this safety cable; the cable is used only to prevent the unit from rolling during the lift.

4. Position isolator pads or spring isolators beneath the chiller feet (see "Unit Isolation," p. 27 for instructions).

Note: Follow instructions provided by the spring isolator manufacturer, being careful to not damage isolator adjustment screw.

5. Once the isolators are in place, lower the chiller—working from end to end—in small increments to maintain stability.
6. When lift is complete, detach the rigging shackles and safety chain.

Figure 4. Typical rigging arrangements for CVHE, CVHF, and CVHG CenTraVac chillers

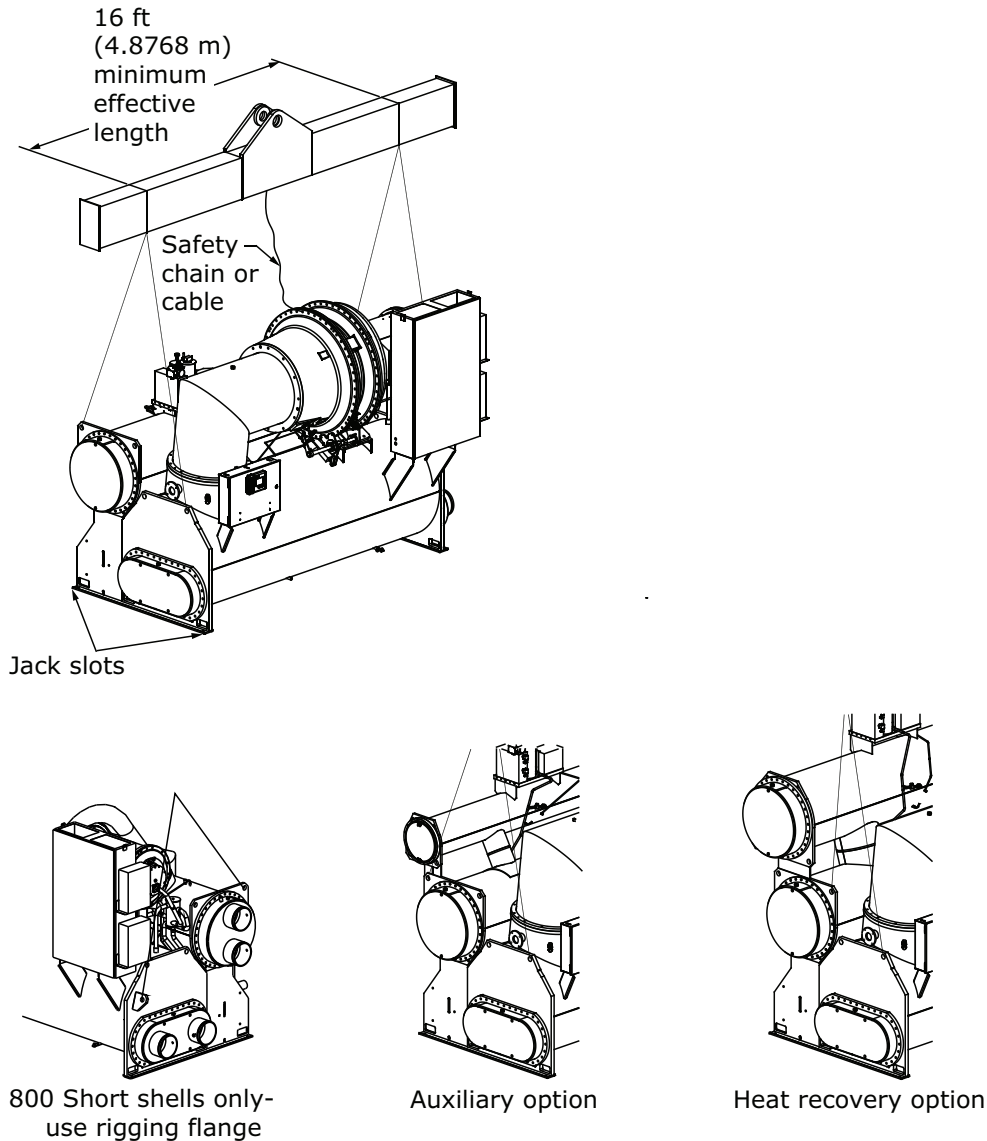

Special Lift Requirements

NOTICE

Oil Loss!

Failure to prevent oil migration out of the oil tank could result in equipment failure or property-only damage.

To prevent oil migration out of the oil tank during lifting procedures, remove the oil from the oil tank if the unit will be lifted at any angle greater than 15° from horizontal end-to-end. If oil is allowed to run out of the oil tank into other areas of the chiller, it will be extremely difficult to return the oil to the oil tank even during operation.

NOTICE

Equipment Damage!

Moving the chiller using a fork lift could result in equipment or property-only damage.

Do not use a fork lift to move the chiller!

NOTICE

Compressor Alignment!

Failure to preserve compressor alignment could result in equipment or property-only damage.

Lifting the compressor/motor assembly from the shells without factory-installed doweling in the compressor casting flanges could result in misalignment of the compressor castings.

If the chiller cannot be moved using a standard chiller lift, consider the following:

- When job site conditions require rigging of the chiller at an angle greater than 45° from horizontal (end-to-end), the unit may require removal of the compressor. Contact Trane or an agent of Trane specifically authorized to perform start-up and warranty of Trane® products regarding the disassembly and reassembly work. For more information, see “Factory Warranty Information,” p. 3.

Note: Disassembly and reassembly work includes dowel-pinning the compressor and removing it from the unit. Contact Trane or an agent of Trane specifically authorized to perform start-up and warranty of Trane® products for specific rigging instructions. Do NOT attempt to rotate the chiller onto its side.

- When lifting the chiller is either impractical or undesirable, attach cables or chains to the jacking slots shown in the figure in “Standard Chiller Lift,” p. 25; then push or pull the unit across a smooth surface. Should the chiller be on a shipping skid, it is not necessary to remove the skid from the chiller before moving it into place.
- If removal of the compressor or economizer assembly is necessary to move the chiller to the operating

location, contact Trane. Also refer to “Factory Warranty Information,” p. 3.

Unit Isolation

To minimize sound and vibration transmission through the building structure and to verify proper weight distribution over the mounting surface, always install isolation pads or spring isolators under the chiller feet.

Note: Isolation pads (refer to the figure in “Isolation Pads,” p. 27) are provided with each chiller unless spring isolators are specified on the sales order.

Specific isolator loading data is provided in the unit submittal package. If necessary, contact your local Trane sales office for further information.

Important: When determining placement of isolation pads or spring isolators, remember that the control panel side of the unit is always designated as the front side of the unit.

Isolation Pads

When the unit is ready for final placement, position isolation pads (18-inch [457.2 mm] sides) end for end under the full length of the chiller leg. The pads measure 9 inch × 18 inch (228.6 mm × 457.2 mm) and on some units there may be small gaps between pads. Pads are provided to cover entire foot. Place pad flush with the outside edge of the chiller foot and leave excess material under the chiller.

Figure 5. Isolation pad and dimensions

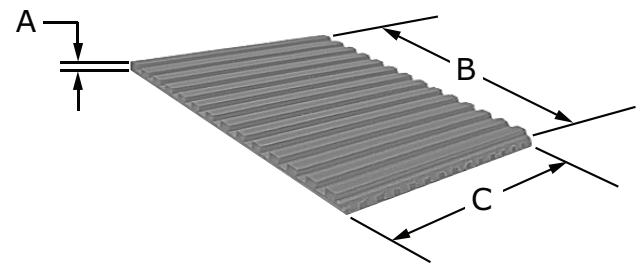

A = 3/8 in. (9.5 mm)

B = 18 in. (457.2 mm)

C = 9 in. (228.6 mm)

Remember that the chiller must be level within 1/16-inch (1.6 mm) over its length and width after it is lowered onto the isolation pads. In addition, all piping connected to the chiller must be properly isolated and supported so that it does not place any stress on the unit.

Spring Isolators

Spring isolators should be considered whenever chiller installation is planned for an upper story location. Base isolator placement is shown in the following figure.

Figure 6. Isolation spring placement by shell size, and evaporator and condenser length

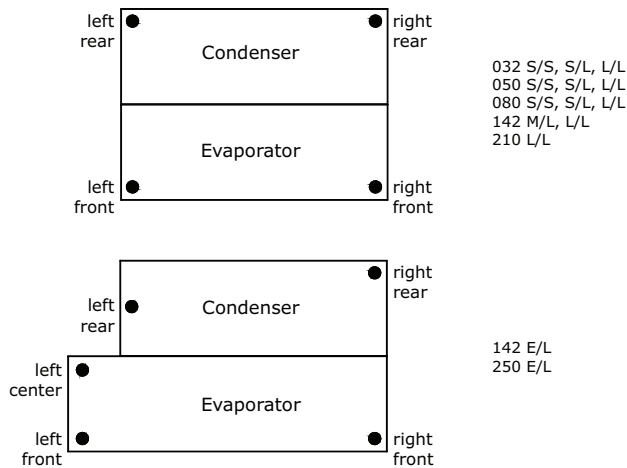

Spring isolators typically ship assembled and ready for installation. To install and adjust the isolators properly, follow the provided instructions.

Note: Do NOT adjust the isolators until the chiller is piped and charged with refrigerant and water.

Important: Do NOT block any serviceable components such as the lubrication system with field-installed devices such as spring isolators.

1. Position the spring isolators under the chiller as shown in the preceding figure. Ensure that each isolator is centered in relation to the tube sheet.

Note: Spring isolators shipped with the chiller may not be identical. Compare the data provided in the unit submittal package to determine proper isolator placement.

2. Set the isolators on the sub-base; shim as necessary to provide a flat, level surface at the same elevation for the end supports.

Important: Support the full underside of the isolator base plate; do NOT straddle gaps or small shims.

3. If required, screw the isolators to the floor through the slots provided, or cement the pads.

Note: Fastening the isolators to the floor is not necessary unless specified.

4. If the chiller must be fastened to the isolators, insert cap screws through the chiller base and into holes drilled and tapped in the upper housing of each isolator.

Important: Do NOT allow the screws to protrude below the underside of the isolator upper housing, or interfere with the adjusting screws. An alternative method of fastening the chiller to the isolators is to cement the neoprene pads.

5. Set the chiller on the isolators; refer to “Standard Chiller Lift,” p. 25. The weight of the chiller will force down the

upper housing of each isolator, and could cause it to rest on the isolator lower housing (refer to the Figure 7, p. 28).

6. Check the clearance on each isolator. If this dimension is less than 1/4-inch (6.35 mm) on any isolator, use a wrench to turn the adjusting screw one complete revolution upward.

Note: When the load is applied to the isolators (refer to Step 5), the top plate of each isolator moves down to compress the springs until either the springs support the load or the top plate rests on the bottom housing of the isolator. If the springs are supporting the load, screwing down on the adjusting screw (refer to Step 7) will raise the chiller.

7. Turn the adjusting screw on each of the remaining isolators to obtain the required minimum clearance of 1/4-inch (6.35 mm).
8. Once the minimum required clearance is obtained on each of the isolators, level the chiller by turning the adjusting screw on each of the isolators on the low side of the unit. Work from one isolator to the next.

Important: The chiller must be level to within 1/16-inch (1.6 mm) over its length and width, and the clearance of each isolator must be at least 1/4-inch (6.35 mm).

Figure 7. Chiller foot and isolator orientation

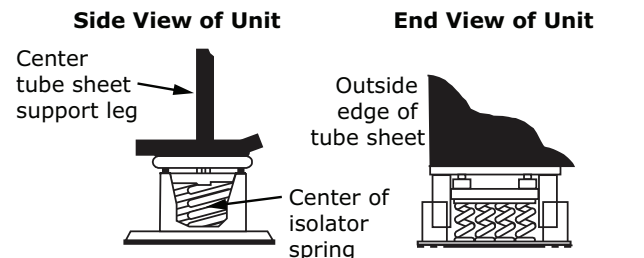

Note: The spring isolator must be centered in relation to the tube sheet. Do not align the isolator with the flat part of the chiller foot since the tube sheet is often off center.

Note: The length of the isolator should be parallel to the leg.

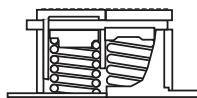
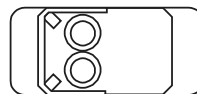

Important: Do NOT install spring isolators or brackets in such a way that they could inhibit chiller servicing such as charging or evacuation, oil tank service, etc.

Leveling the Unit

The chiller must be set level within 1/16-inch (1.6 mm).

1. Measure and make a punch mark an equal distance up from the bottom of each foot of the chiller.
2. Suspend a clear plastic tube along the length of the chiller as shown in the .
3. Fill the tube with water until the level aligns with the

punch mark at one end of the chiller.

4. Check the water level at the opposite mark. If the water level does not align with the punch mark, use full length shims to raise one end of the chiller until the water level at each end of the tube aligns with the punch marks at both ends of the chiller.
5. Once the unit is level across its length, repeat the first three steps to level the unit across its width.

Figure 8. Leveling the chiller

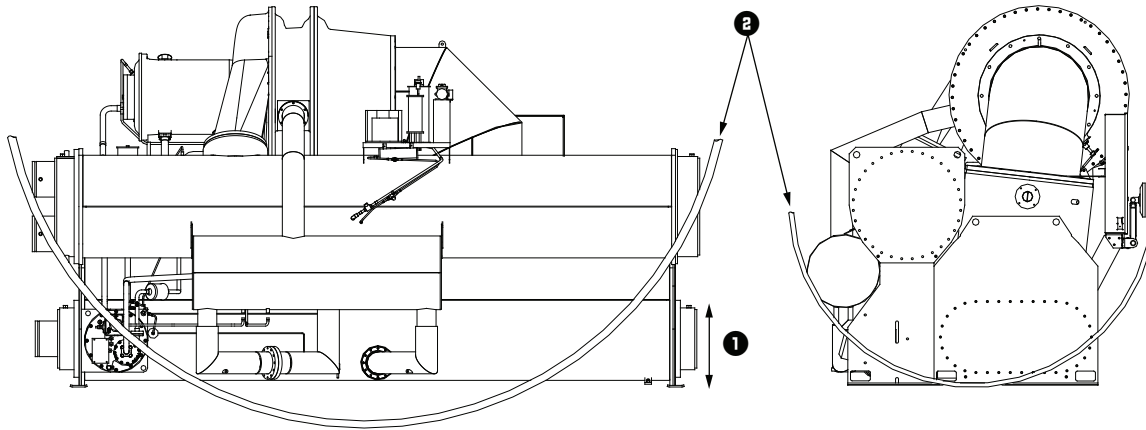

Note: Use of a laser level is an acceptable alternative method to level the unit.

Important: Immediately report any unit damage incurred during handling or installation at the job site to the Trane sales office.



Installation: Water Piping

Overview

The following water piping circuits must be installed and connected to the chiller:

- Pipe the evaporator into the chilled water circuit.
- Pipe the condenser into the cooling tower water circuit.
- *Optional:* A heat-recovery condenser water circuit.
- *Optional:* An auxiliary condenser water circuit.

Note: *Piping must be arranged and supported to avoid stress on the equipment. It is strongly recommended that the piping contractor does not run pipe closer than 3 feet (0.9 m) minimum to the equipment. This will allow for proper fit upon arrival of the unit at the job site. Any adjustment that is necessary can be made to the piping at that time. Expenses that result from a failure to follow this recommendation will NOT be paid by Trane.*

Piping suggestions for each of the water circuits listed above are outlined in “Evaporator and Condenser Water Piping,” p. 33. General recommendations for the installation of field-supplied piping components (e.g., valves, flow switches, etc.) common to most chiller water circuits are listed in the following sections.

Water Treatment

The use of untreated or improperly treated water in a CenTraVac® chiller may result in inefficient operation and possible tube damage.

Important: *Trane strongly recommends using the services of a qualified water treatment specialist to determine necessary water treatment. A label with a customer disclaimer note is affixed to each unit.*

NOTICE

Proper Water Treatment Required!

The use of untreated or improperly treated water could result in scaling, erosion, corrosion, algae or slime.

Use the services of a qualified water treatment specialist to determine what water treatment, if any, is required. Trane assumes no responsibility for equipment failures which result from untreated or improperly treated water, or saline or brackish water.

Water Pressure Gauges

Locate pressure gauge taps in a straight length of pipe. Place each tap a minimum of one pipe diameter downstream of any elbow, orifice, etc. For example, for a 6-inch (16 cm) pipe, the tap would be at least 6-inch (16 cm) from any elbow, orifice, etc.

Valves – Drains and Vents

NOTICE

Waterbox Damage!

Failure to follow instructions could result in damage to the waterbox.

Do not over-tighten or use excessive Teflon® pipe tape when installing valves, drains, plugs and vents on waterboxes.

1. Install field-supplied air vents and drain valves on the waterboxes. Each waterbox is provided with a National Pipe Thread (NPTF) vent and drain connection; depending on the waterbox types ordered, the openings may be 1/4-inch (6.35 mm), 1/2-inch (12.7 mm), or 3/4-inch (19.05 mm).

NOTICE

Waterbox Damage!

Failure to follow instructions could result in damage to the waterbox due to hydrostatic expansion.

Install pressure-relief valves in the condenser and evaporator water circuits.

NOTICE

Equipment Damage!

Failure to follow instructions could result in equipment damage.

Do NOT allow chiller to freeze! Bundles must be drained and air-blown dry if chiller is stored in an unheated equipment room.

2. If necessary for the application, install pressure-relief valves at the drain connections on the evaporator and condenser waterboxes. To do so, add a tee with the relief valve attached to the drain valve.

To determine whether or not pressure relief valves are needed for a specific application, keep in mind that:

- a. Vessels with close-coupled shutoff valves may cause high potentially damaging hydrostatic pressures as fluid temperature rises.
- b. Relief valves are required by American Society of Mechanical Engineers (ASME) codes when the shell waterside is ASME. Follow ASME guidelines or other applicable codes to ensure proper relief valve installation.

Strainers

NOTICE

Water Borne Debris!

To prevent components damage, pipe strainers must be installed in the water supplies to protect components from water borne debris. Trane is not responsible for equipment-only-damage caused by water borne debris.

Install a strainer in the entering side of each piping circuit to avoid possible tube plugging in the chiller with debris.

Required Flow-Sensing Devices

Use flow paddle switches see the “Paddle Switches,” p. 31), differential pressure switches, or ifm efector® flow detection controllers and sensors (see the “Water Flow Detection Controller and Sensor,” p. 31) in conjunction with the pump interlocks to verify evaporator and condenser water flows.

To ensure adequate chiller flow protection, wire the chiller water and condenser water proof of flow devices per the as-built schematics and submittal, and in accordance with associated notes.

Unless stated otherwise, all flow sensing devices must be field supplied. Be sure to follow the manufacturer recommendations for device selection and installation.

Also, review the following general flow switch installation guidelines.

Paddle Switches

Figure 9. Flow paddle switch installation

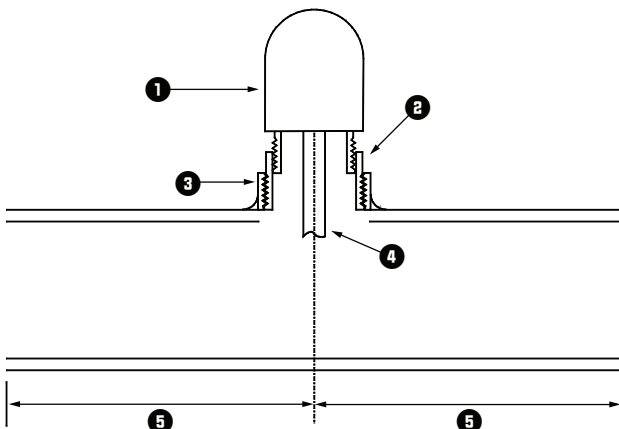

1. Flow switch body
2. One (1) pipe size larger bushing to avoid paddle interference
3. Pipe coupling
4. Flow switch paddle
5. Five (5) pipe diameters (no turns or fittings)

Paddle switch installation:

1. Mount the flow paddle switch upright in horizontal section of pipe. Allow at least five pipe diameters of straight, horizontal run on each side of the switch. Whenever possible, avoid locations adjacent to elbows, orifices, and valves.
2. To ensure that the flow switch operates as designed, adjust the length of the flow switch paddle to compensate for the pipe diameter and the height of the coupling used to install the switch.
3. Install the flow switch using a coupling that is large enough to allow the insertion of a bushing one pipe diameter larger than the flow switch base as shown in the preceding figure. This will prevent interference with the flow switch paddle.
4. Verify that the direction-of-flow arrow on the switch points in the same direction as actual water flow through the piping circuit.
5. Remove all air from the piping circuit to prevent possible flow switch fluttering.
6. Adjust the flow switch to open when water flow is less than normal.

Water Flow Detection Controller and Sensor

Important: Before installing the ifm efector® flow detection controller and sensor, use a marker to draw a line on the probe at 3.5-inch (8.9 cm) from the end of the probe. Do NOT insert more than 3.5-inch (8.9 cm) of the probe length into the pipe. Refer to the following figure.

Installation: Water Piping

Figure 10. Installation of ifm efector flow detection controller and sensor

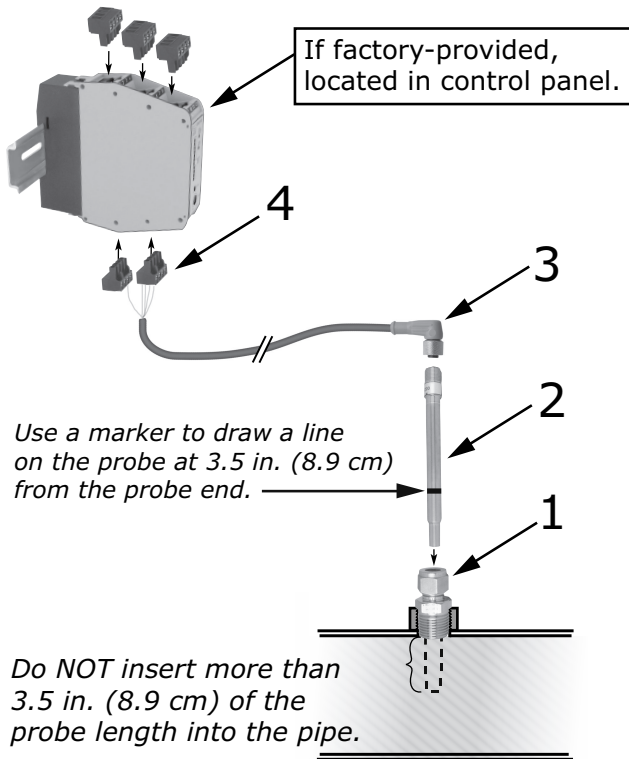

1. Mount the 1/2-inch NPT adapter in a horizontal or vertical section of pipe. The maximum distance from the control panel must not exceed 29.5 feet (9 m) (see item labeled 1 in the preceding figure). Allow at least five pipe diameters straight run of pipe upstream of the sensor location, and three pipe diameters straight run of pipe downstream of the sensor location.

Note: In the case of a horizontal pipe, mounting the sensor in the side of the pipe is preferred. In the case of a vertical pipe, mounting the sensor in a place where the water flows upwards is preferred.

NOTICE

Overtightening!

Do not exceed torque specifications as it could result in equipment damage.

2. Insert the flow sensor probe (see item labeled 2 in the preceding figure) through the 1/2-inch NPT adapter so that 3 to 3.5-inch (7.6 to 8.9 cm) of the probe length extends into the pipe. Tighten the 1/2-inch NPT adapter as needed to prevent leakage and keep the probe from backing out under pressure. **Do NOT exceed 40 ft·lb (54.2 N·m) of torque on the fitting. Sensor damage can occur if it is overtightened.**

Note: When installed, the tip of the ifm efector® sensor probe must be at least 1-inch (2.54 cm) away from any pipe wall. Do NOT insert more than 3.5-inch (8.9 cm) of the probe length into the pipe.

3. Install the Micro DC Cable by inserting it through the wire openings on the back side of the control panel (see item labeled 3 in the preceding figure). Install the supplied Micro DC Cable (29.5 ft. [9 m] in length) to the Flow Probe and hand-tighten the connector nut.
4. Plug the other end of the Micro DC Cable into the Flow Control Monitor with the Combicon connector (see item labeled 4 in the preceding figure). Refer to the following figure for cable wiring.

NOTICE

Do Not Apply Electrical Power to a Unit in a Vacuum!

Failure to follow instructions below could result in motor and compressor damage.

Do not apply electrical power to a motor in a vacuum.

For units with inside-the-delta solid state starters, disconnect power to unit during evacuation or when the unit is in a deep vacuum. In addition, on units with inside-the-delta solid state starters, all power to the unit must be disconnected prior to evacuating the unit as line power is directly applied to the motor terminals 4, 5, and 6.

5. Apply power to the chiller control panel to verify the Flow Control Monitor has power and the Low Volt Broken Wire Relay light is NOT lit.
6. Remove all air from the piping circuit prior to adjusting the low water flow setpoint.
7. Reduce the water flow to the minimum allowable flow and adjust the Flow setting on the Flow Control Monitor (see item labeled 7 in the following figure). Adjusting the **Flow** potentiometer clockwise (+) reduces the flow setting cutout and adjusting counterclockwise (-) increases the flow setting cutout.

Note: The **Temp** potentiometer on the ifm efector® control module has no effect in Trane application. It is NOT necessary to make adjustments to the Temp potentiometer.
8. After the cutout setting is adjusted, the cutout setpoint will be indicated with a yellow light on the Flow Control Monitor LED bar graph display. When the water flows are higher than the cutout, a green light will indicate proper flow status. If the flows fall below the cutout setpoint, a red light will indicate low/no flow status.

Figure 11. ifm efector® flow sensing device terminal connection

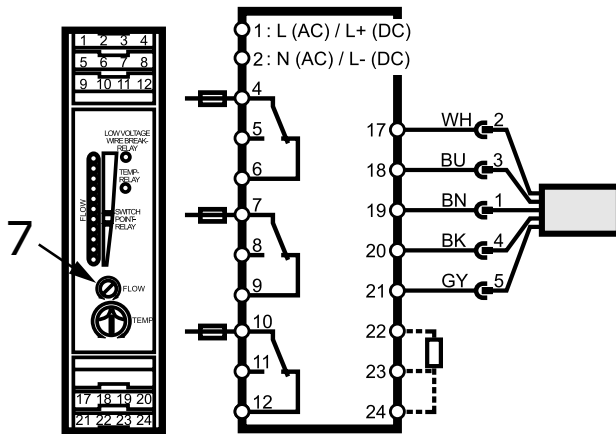

NOTICE

Proof of Flow Switch!

Failure to provide flow switches or jumping-out of switches could result in severe equipment damage. Evaporator and condenser water circuits require proof of flow switches.

- Failure to include the proof of flow devices and/or jumping out these devices could cause the unit to stop on a secondary level of protection.
- Frequent cycling on these higher level diagnostic devices could cause excessive thermal and pressure cycling of unit components (O-rings, gaskets, sensors, motors, controls, etc.) and/or freeze damage, resulting in premature failure of the chiller.

Evaporator and condenser proof of flow switches (either flow or Delta-P) are required as shown on wiring diagrams. These switches are used with control logic to confirm flow prior to starting a unit and to stop a running unit if flow is lost. For troubleshooting, a viewable diagnostic is generated if a proof of flow switch does not close when flow is required.

Evaporator and Condenser Water Piping

The following two figures illustrate the recommended (typical) water piping arrangements for the evaporator and condenser.

Figure 12. Typical evaporator water piping circuit

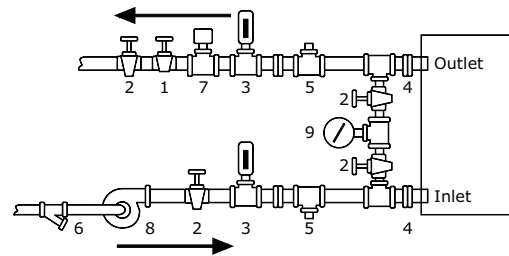

1. Balancing valve.
2. Gate (Isolation) valve or ball valve.
3. Thermometer (if field supplied).
4. Waterbox nozzle connection.
5. Drain, vent, and anode.
6. Strainer.
7. Chilled water flow switch (5S1). Flow switch 5S1 may be installed in the entering leg of the chilled water circuit.
8. Pump.
9. Pressure gauge. It is recommended to pipe the gauge between entering and leaving pipes. A shutoff valve on each side of the gauge allows the operator to read either entering or leaving water pressure.

Figure 13. Typical condenser water piping circuits

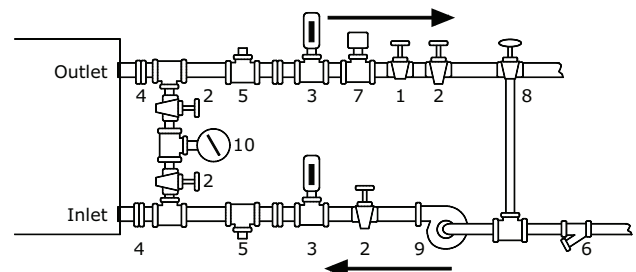

1. Balancing valve.
2. Gate (isolation) valve or ball valve.
3. Thermometer (if field supplied).
4. Waterbox nozzle connection.
5. Drain, vent, and anode.
6. Strainer.
7. Condenser water flow switch (5S2). Flow switch 5S2 may be installed in either the entering or leaving leg of the chilled water circuit.
8. Three-way valve (optional).
9. Condenser water pump.
10. Pressure gauge. It is recommended to pipe a single gauge between entering and leaving pipes.



Installation: Water Piping

Notes:

- *Some type of field-supplied temperature control device may be required to regulate the temperature of the heat-recovery condenser water circuit. For application recommendations, see Heat Recovery Seminar (Part 2): Systems/ Equipment (AM-FND-8).*
- *Install a bypass valve system to avoid circulating water through the auxiliary shell when the unit is shutdown.*
- *On multiple-pass condensers, entering condenser water must enter at the lowest nozzle.*

Piping must be arranged and supported to avoid stress on the equipment. It is strongly recommended that the piping contractor does not run pipe closer than 3 feet (0.9 m) minimum to the equipment. This will allow for proper fit upon arrival of the unit at the job site. Any adjustment that is necessary can be made to the piping at that time. Expenses that result from a failure to follow this recommendation will NOT be paid by Trane.

Water piping connection sizes and components are identified in the tables in “Water Piping Connections,” p. 34 and “Grooved Pipe Coupling,” p. 35. Remember that with many waterboxes, the entering and leaving evaporator water can be piped to either waterbox connection when the tube bundles are split vertically. However, large evaporator waterboxes with entering and leaving connections not at the same level must be connected with the entering water at the bottom and the leaving water at the top.

Waterboxes with multiple pass arrangements utilize a baffle to separate the passes. These baffles are designed for a maximum pressure of 20 psid (137.9 kPaD). If larger pressure drops are expected in the application, contact your local Trane representative to discuss special waterbox options.

Important: *Water flows must be piped in accordance with nameplate designation.*

Field-provided isolation valves for the evaporator and condenser water lines should be installed upstream and downstream of the heat exchangers, and be installed far enough away from the chiller to also provide practical service isolation for flow sensing devices, field thermometers, flexible connectors, and any removable pipe spools.

Ensure that the evaporator water piping is clear; check it after the chilled water pump is operated but before initial chiller start-up. If any partial blockages exist, they can be detected and removed to prevent possible tube damage resulting from evaporator freeze-up or erosion.

For condenser and large evaporator connections, arrange the water piping so that the water supply enters the shell at the lower connection and exits from the top connection. Operational problems may result if this piping is not correct. Some shells may be piped as desired since both connections are at the same level.

For applications that include an infinite source or multiple-use cooling condenser water supply, install a valved bypass leg (optional) between the supply and return pipes. This valved bypass allows the operator to short-circuit water flow through the cooling condenser when the supply water temperature is too low. For additional application information, see *CenTraVac® Water-cooled Chillers Models CDHF, CDHG, CVHE, CVHF, CVHG Condenser Water Temperature Control Engineering Bulletin (CTV-PRB027*-EN)*.

Notes:

- *System refrigerant pressure differential must be maintained above 3 psid (20.7 kPaD) at all times. Failure to do so could result in operating problems.*
- *Whenever a CVHE, CVHF, or CVHG CenTraVac® chiller is equipped with an auxiliary condenser, use a bypass valve system to avoid circulating water through the auxiliary shell during unit shut-down.*

Water Piping Connections

All standard units use grooved-pipe connections. These are grooved-end NSP (Victaulic® style) pipe connections. Flanged connections are optional.

Piping joined using grooved type couplings, like all types of piping systems, requires proper support to carry the weight of pipes and equipment. The support methods used must eliminate undue stresses on joints, piping, and other components, allow movement where required, and provide for any other special requirements (i.e., drainage, etc.).

Note: *If needed, plug-type sensor extension cables are available for purchase from Trane Parts Service. These sensor extension cables may be necessary if the waterboxes are changed or if the temperature sensors are moved out into the unit piping for better mixed temperature readings.*

Table 9. Evaporator water piping connection sizes

EVSZ ^(a)	Nominal Pipe Size					
	1-Pass		2-Pass		3-Pass	
	in.	mm	in.	mm	in.	mm
032	8	219.1	6	168.3	5	141.3
050	10	273.0	8	219.1	6	168.3
080	12	323.9	10	273.0	8	219.1
142	16	406.4	12	323.9	10	273.0
210	16	406.4	14	355.6	12	323.9
250	16	406.4	14	355.6	12	323.9

^(a) EVSZ = Evaporator Shell Size; S = Short Shell, L = Long Shell, E = Extended Shell

Table 10. Condenser water piping connection sizes

CDSZ ^(a)	Nominal Pipe Size	
	2-Pass	
	in.	mm
032	6	168.3
050	8	219.1
080	10	273.0
142	12	323.9
210	14	355.6
250	14	355.6

^(a) CDSZ =Condenser Shell Size; S = Short Shell, L = Long Shell, E = Extended Shell

Figure 14. Typical grooved pipe connection

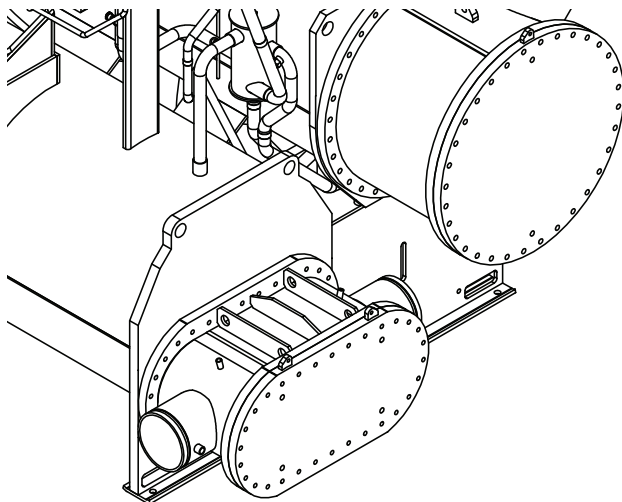
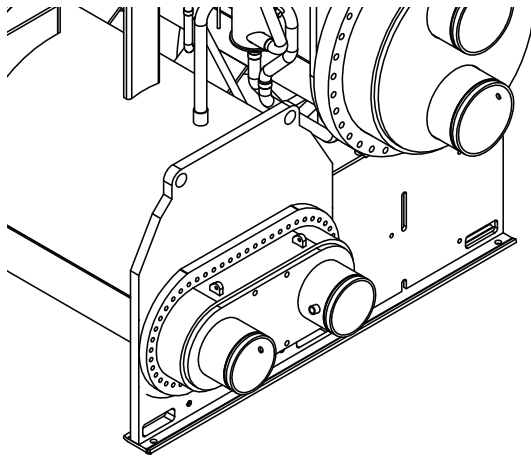

Waterbox Locations

Important: Do NOT exchange positions of marine-style waterboxes. Proper unit operation and proper water flow could be affected by repositioning marine-style waterboxes. Contact CenTraVac™ Chiller Technical Service for more information.

If necessary, the non-marine-style waterboxes on each shell—whether evaporator or condenser—can be switched end-for-end to obtain the desired piping arrangement.

If removal of waterboxes is necessary, see the “Waterbox Removal and Installation,” p. 94.

If the waterboxes on any of the shells are exchanged end-for-end, be sure to reinstall them right-side up to maintain the correct baffle arrangements. Use a new gasket with each waterbox cover.

Grooved Pipe Coupling

A customer-supplied, standard flexible grooved pipe coupling (Victaulic® Style 77 or equivalent) should be used to complete the Victaulic® connection for both 150 psig (1034.2 kPaG) and 300 psig (2068.4 kPaG) waterboxes.

When a flexible coupling such as this is installed at the waterbox connections, other flexible piping connectors (i.e., braided-steel, elastomeric arch, etc.) are not usually required to attenuate vibration and/or prevent stress on the connections.

Table 11. Water piping connection components

Unit Model	Unit Connection Type	Customer Piping Connection	
		Victaulic®	Flanged
CVHE and CVHG	Flanged (Condenser 032–050 150 psig [1034.2 kPaG] non-marine only)	Customer provided Victaulic® coupling	No adapter required
CVHE, CVHF, and CVHG	Victaulic® (all others)	Customer provided Victaulic® coupling	Trane provided Victaulic®-to-flange adapter

Figure 15. Customer piping connection types

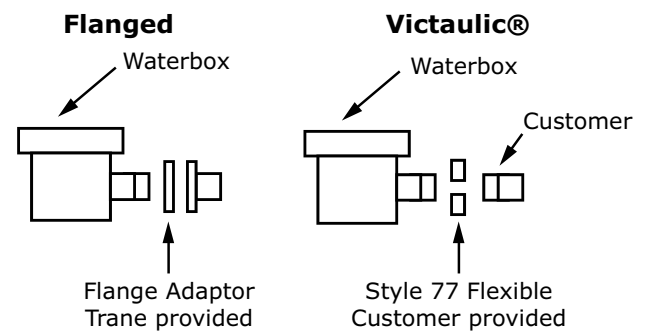

Notes:

- Refer to the coupling manufacturer's guidelines for specific information concerning proper piping system design and construction methods for grooved water piping systems.
- Flexible coupling gaskets require proper lubrication before installation to provide a good seal. Refer to the coupling manufacturer's guidelines for proper lubricant type and application.

Flange-connection Adapters

NOTICE

Never Weld to Cast Boxes!

Welding to cast boxes will result in equipment damage.

Adapters must be used to convert flanges.

When flat-face flange connections are specified, flange-to-groove adapters are provided (Victaulic® Style 741 for 150 psig [1034.2 kPaG] systems; Style 743 for 300 psig [2068.4 kPaG] systems). The adapters are shipped screwed to one of the chiller end-supports. Adapter descriptions are given in the tables in "Victaulic Gasket Installation," p. 36. The flange adapters provide a direct, rigid connection of flanged components to the grooved-pipe chiller waterbox connections.

Figure 16. Typical shipping location for flange

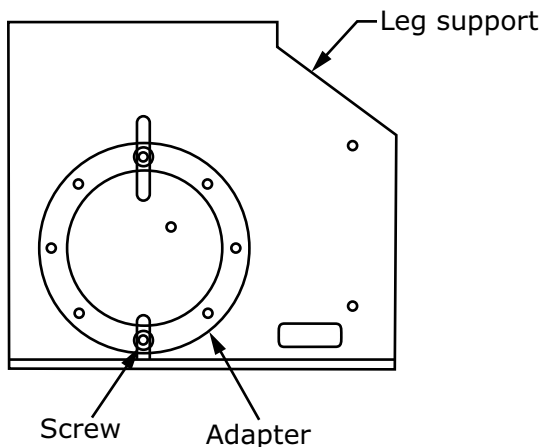

In this case, the use of flexible type connectors (i.e., braided steel, elastomeric arch, etc.) are recommended to attenuate vibration and prevent stress at the waterbox connections. Flange adapters are not provided for CVHE, CVHF, or CVHG CenTraVac™ chillers with 300 psig (2068.4 kPaG) waterboxes that have 14 in. (355.6 mm) and 16 in. (406.4 mm) piping connections.

All flange-to-flange assembly screws must be provided by the installer. Hex head screw sizes and number required are included in the tables in "Victaulic Gasket Installation," p. 36. The four draw-bolts needed for the

14 in. (355.6 mm) and 16-inch (406.4 mm) Style 741 (150 psig [1034.2 kPaG]) adapters are provided. The Style 741 (150 psig [1034.2 kPaG]) flange adapter requires a smooth, hard surface for a good seal.

Connection to other type flange faces (i.e., raised, serrated, rubber, etc.) requires the use of a flange washer between the faces. Refer to the flange adapter manufacturer guidelines for specific information.

The Style 743 (300 psig [2068.4 kPaG]) flange adapters are designed to mate with raised-face flanges. They can be used with flat-faced flanges, but only if the raised projections on the outside face of the adapter are removed; refer to the following figure. The flange-adapter gasket must be placed with the color-coded lip on the pipe and the other lip facing the mating flange.

NOTICE

Piping Connection Leaks!

Failure to provide effective seal could result in equipment or property-only damage.

To provide effective seal, gasket contact surfaces of adapter must be free of gouges, undulations or deformities.

Figure 17. Modifying 300 psig (2068.4 kPaG) flange adapters for flat-faced flange application

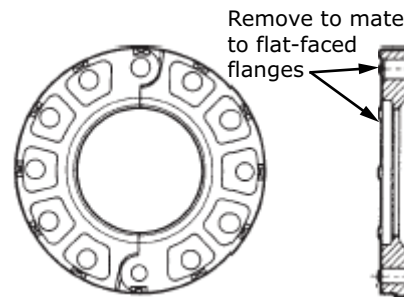

Victaulic Gasket Installation

1. Inspect supplied gasket to be certain it is suited for intended service (code identifies gasket grade). Apply a thin coat of silicone lubricant to gasket tips and outside of gasket.
2. Install gasket, placing gasket over pipe end and making sure gasket lip does not overhang pipe end. Refer to the following figure for gasket configuration.
3. Align and bring two pipe ends together and slide gasket into position centered between the grooves on each pipe. No portion of the gasket should extend into the groove on either pipe.
4. Open fully and place hinged Victaulic® flange around the grooved pipe end with the circular key section locating into the groove.
5. Insert a standard hex head screw through the mating holes of the Victaulic® flange to secure the flange firmly in the groove.

6. Tighten fasteners alternately and equally until housing screw pads are firmly together (metal-to-metal); see “Screw-Tightening Sequence for Water Piping Connections,” p. 37. Do NOT excessively tighten fasteners.

Note: Uneven tightening may cause the gasket to pinch.

Figure 18. Typical Victaulic® flange gasket configuration

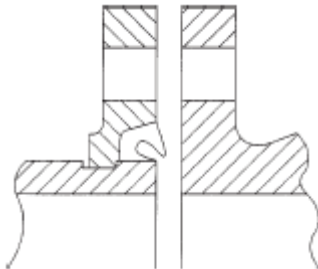

Table 12. Installation data for 150 psig (1034.2 kPaG) flange adapters (Style 741)

Nominal Pipe Size		Assembly Screw Size ^(a)	Number of Assembly Screws Required	Screw Pattern Diameter		Weight	
in.	mm			in.	in.	mm	lb
4	114.3	5/8 x 3	8	7.5	191	7.7	3.5
5	141.3	3/4 x 3-1/2	8	8.5	216	9.3	4.2
6	168.3	3/4 x 3-1/2	8	9.5	241	10.3	4.7
8	219.1	3/4 x 3-1/2	8	11.75	298	16.6	7.5
10	273.0	7/8 x 1/44	12	14.25	362	24.2	11.0
12	323.9	7/8 x 1/4	12	17	432	46.8	21.2
14	355.6	1 x 4-1/2	12	18.75	476	75	34.0
16	406.4	1 x 4-1/2	16	21.25	540	90	40.8

^(a) Screw size for conventional flange-to-flange connection. Longer screws are required when flange washer must be used.

Table 13. Installation data for 300 psig (2068.4 kPaG) flange adapters (Style 743)

Nominal Pipe Size		Assembly Screw Size ^(a)	Number of Assembly Screws Required	Screw Pattern Diameter		Weight	
in.	mm			in.	in.	mm	lb
4	114.3	3/4 x 3-3/4	8	7.88	200	15.3	6.9
5	141.3	3/4 x 4	8	9.25	235	17.7	8.0
6	168.3	3/4 x 4-1/2	12	10.63	270	23.4	10.6
8	219.1	3/4 x 4-3/4	12	13	330	34.3	15.6
10	273.0	1 x 5-1/4	16	15.25	387	48.3	21.9
12	323.9	1-1/8 x 5-3/4	16	17.75	451	70.5	32.0

^(a) Screw size for conventional flange-to-flange connection. Longer screws are required when flange washer must be used.

Screw-Tightening Sequence for Water Piping Connections

This section describes a screw-tightening sequence for flanges with flat gaskets or O-rings. Remember that improperly tightened flanges may leak.

Note: Before tightening any of the screws, align the flanges. Flange screw torque requirements are provided in the following table.

Table 14. Flange screw torque recommendations for O-ring and flat-gasket piping connections

Screw Size		Gasket Type			
		O-Ring		Flat	
in.	mm	ft.-lb	N·m	ft.-lb	N·m
3/8	9.5	25	34	12–18	16–24
1/2	13	70	95	33–50	45–68
5/8	16	150	203	70–90	95–122
3/4	19	250	339	105–155	142–210

Note: Screw size is determined by the diameter of the screw shank.

Flanges with 4, 8, or 12 Screws

Tighten all screws to a snug tightness, following the numerical sequence for the appropriate pattern as shown in the following figure. Repeat this sequence to apply the final torque to each screw.

Figure 19. Flange screw tightening sequence (4, 8, or 12 screws)

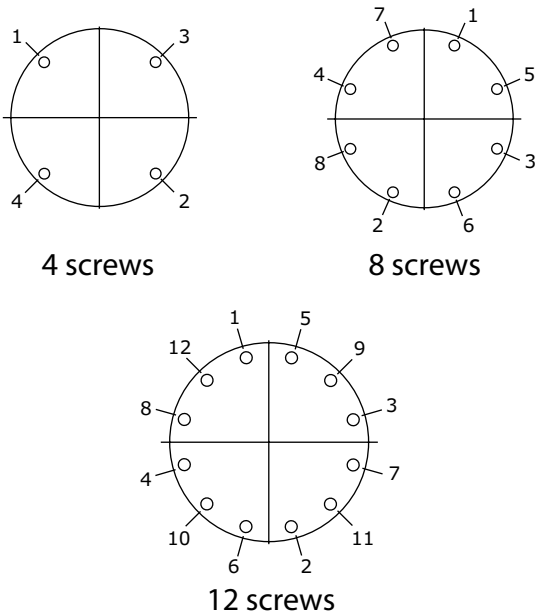

Flanges with 16, 20, or 24 Screws

Tighten only the first half of the total number of screws to a snug tightness, following the numerical sequence for the appropriate pattern as shown in the following figure. Next, sequentially tighten the remaining half of the screws in numerical order.

Figure 20. Flange screw tightening sequence (16, 20, or 24 screws)

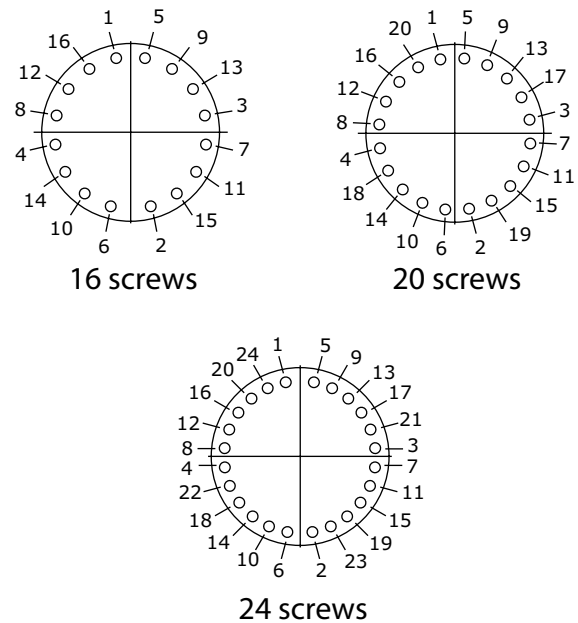

Flanges with More than 24 Screws

Sequentially tighten the first 12 screws to a snug tightness, following the numerical sequence as shown in the following figure. Tighten the next 12 consecutively numbered screws in sequence to the final torque. Then, apply final torque to the first 12 screws and the screws not yet tightened (i.e., unnumbered screws in the following figure). Start with screw "1" and move progressively around the flange in a clockwise direction.

Figure 21. Flange screw tightening sequence (more than 24 screws)

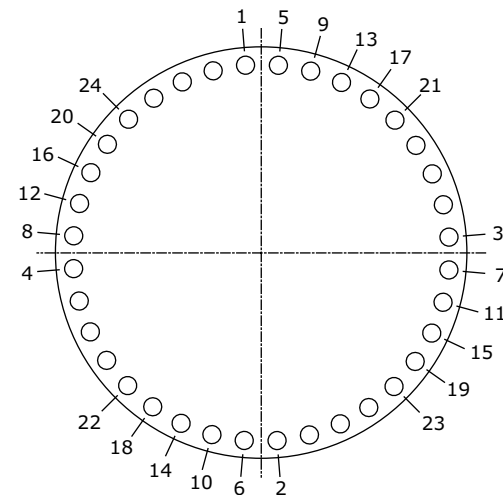

Evaporator Waterbox Covers

Ensure that the waterbox head rests tightly against the tube sheet, and then snugly tighten the 26 bolts in

sequential order as shown in the following figure. If excessive tube sheet crown prevents the head from contacting the tube sheet, tighten the bolts located where the greatest gaps occur. Be sure to use an equal number of bolt turns from side to side. Then, apply final torque to each bolt in sequential order.

Figure 22. Evaporator waterbox cover bolt tightening sequence

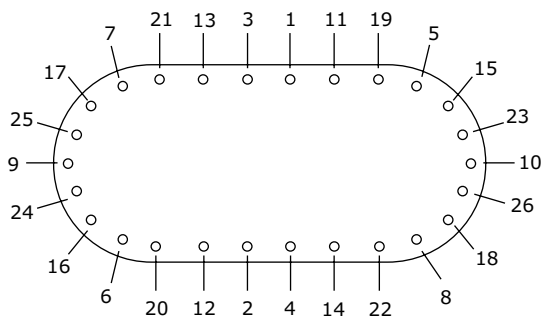

Pressure Testing Waterside Piping

NOTICE

Equipment Damage!

Failure to follow these instructions could result in equipment damage.

Do not over pressurize the system or exceed design pressure. Always perform a hydro pressure test with water present in piping and waterboxes.

Waterside design pressure is either 150 psig (1034.2 kPaG) or 300 psig (2068.4 kPaG); refer to unit nameplate or to submittal documentation.

Eddy Current Testing

Trane recommends conducting an eddy current inspection of the condenser and evaporator tubes in water-cooled chillers every three years. Eddy current tests are intended to identify defects on or within the walls of heat exchanger tubing that could lead to in-service tube failures. Eddy current tests conducted before a chiller is put into service are considered “baseline” eddy current tests, and are intended to establish a reference point to aid in the interpretation of future eddy current test reports. Many of the anomalies that can be found through eddy current testing have no impact on tube life or performance, while others are severe enough to justify removing the affected tube from service. Ask your sales account manager for a copy of the *Eddy Current Testing, Engineering Bulletin* (CTV-PRB024*-EN) for clarification of the role of eddy current testing in chiller maintenance by providing information about eddy current technology and heat exchanger tubing.



Vent Piping

Refrigerant Vent Line

General Requirements

State and local codes, and ASHRAE Standard 15 contain requirements for venting the relief device on the chiller to the atmosphere outside of the building. These requirements include, but are not limited to, permitted materials, sizing, and proper termination.

Note: *The following information is a general outline of vent-line installation requirements based on ASHRAE Standard 15. Most codes contain similar requirements but may vary in some significant areas. The installer must check state and local codes and follow the specific requirements applicable to the location.*

Purge Discharge

To comply with ASHRAE Standard 15, the discharge piping from purge units that remove non-condensable gas from refrigerating systems must conform to the ASHRAE Standard 15 requirements for relief piping. To help meet this requirement, the purge discharge is factory-piped to the relief device assembly.

Vent Line Materials

All materials in the relief device vent system must be compatible with the refrigerant in use. Commonly used and accepted piping materials include steel and drain/waste/vent (DWV) copper. Consult local codes for restrictions on materials. Consult with the manufacturers of any field-provided components or materials for acceptable material compatibility.

Note: *PVC piping is compatible with the refrigerant but the glue that joins the sections of plastic pipe may not be. When considering a vent system constructed of plastic piping such as PVC, ensure that both the pipe material and the adhesive have been tested for refrigerant compatibility. In addition, verify that the local codes permit PVC for refrigerant vent lines; even though ASHRAE Standard 15 doesn't prohibit its use, some local codes do.*

Testing conducted in Trane laboratories has qualified the following materials for PVC pipe construction as being compatible with the refrigerant:

Primer/Cleaner:

- Hercules – PVC Primer #60-465
- RECTORSEAL® PVC Cleaner – Sam™ CL-3L

Adhesives:

- Hercules – Clear PVC, Medium Body/Medium Set, #60-020
- RECTORSEAL® – PVC Cement, Gene™ 404L

Flexible connection devices for vibration isolation must also be compatible with the vented refrigerant. A flexible stainless-steel pump connector (such as the stainless-steel type MFP, style HNE, flexible pump connector from Vibration Mounting and Control, Inc.) or equivalent is recommended.

Vent Line Sizing

Vent line size must conform to local codes and requirements. In most cases, local codes are based on ASHRAE Standard 15. ASHRAE Standard 15 provides specific requirements for the discharge piping that allows pressure-relief devices to safely vent refrigerant to the atmosphere if over-pressurization occurs. In part, the standard mandates that:

- The minimum pipe size of the vent line must equal the size of the discharge connection on the pressure-relief device. A larger vent line size may be necessary, depending on the length of the run.
- Two or more relief devices can be piped together *only if* the vent line is sized to handle all devices that could relieve at the same time.
- When two or more relief devices share a common vent line, the shared line must equal or exceed the sum of the outlet areas of all upstream relief devices, depending on the resulting back pressure.

ASHRAE Standard 15 provides guidance for determining the maximum vent line length. It also provides the equation and data necessary to properly size the vent line at the outlet of a pressure-relief device or fusible plug (for more information, refer to “[Vent Line Sizing Reference](#),” p. 44).

The equation accounts for the relationship between pipe diameter, equivalent pipe length, and the pressure difference between the vent line inlet and outlet to help ensure that the vent line system provides sufficient flow capacity.

The table in “[Vent Line Sizing Reference](#),” p. 44 provides additional information based on ASHRAE Standard 15, including:

- Capacities of various vent line sizes and lengths. However, this data applies only to conventional pressure-relief valves and NOT to balanced relief valves, rupture members (as used on Trane® centrifugal chillers), fusible plugs, or pilot-operated valves.
- A simplified method to determine the appropriate vent-line size, using the figure in “[Vent Line Sizing Reference](#),” p. 44. Enter the figure with the total **C** value, read across to a pipe curve and down to find the maximum allowable length for that size pipe.

Note: To determine the total **C** value for a specific unit, add the appropriate **C** values for the evaporator, standard condenser, and economizer. If the unit is equipped with any options (e.g., heat recovery, free cooling, or an auxiliary condenser), add the applicable **C** value(s) for those options to the total as well.

Note: The table and figure in “Vent Line Sizing Reference,” p. 44 are applicable only for non-manifolded vent-line runs connected to a 15 psig (103.4 kPaG) rupture disk relief device. The pipe length provided by the table is in “equivalent feet.” The vent-line length in equivalent feet is the sum of the linear pipe length plus the equivalent length of the fittings (e.g., elbows).

Vent Line Installation

Important: Before constructing the rupture disk vent line, consult local codes for applicable guidelines and constraints.

All CenTraVac® centrifugal chillers are equipped with rupture disks. If refrigerant pressure within the evaporator exceeds 15 psig (103.4 kPaG), the rupture disk breaks and shell pressure is relieved as refrigerant escapes from the chiller.

A cross-section of the rupture disk assembly appears in the following figure (rupture disk location and cross section), along with an illustration indicating the location of the rupture disk on the suction elbow.

Important: If a RuptureGuard™ is to be installed, remove and discard the factory-installed rupture disk; for more information, see RuptureGuard™ Pressure Relief System Option For Use with Water-Cooled CenTraVac® Chillers Installation, Operation, and Maintenance (CTV-SVX06*-EN).

Several general recommendations for rupture disk vent line installation are outlined as follows.

Note: If the rupture disk was removed for service or vent-line piping installation, the rupture disk must be reinstalled (as shown in the following figure [rupture disk location and cross section]). See the following procedure and contact CenTraVac® Chiller Technical Service when reinstalling the rupture disk.

- Verify that the vacuum support side of the rupture disk is positioned as shown in the cross-section view that appears in the following figure (rupture disk location and cross section).
 - Install the two bottom hex head screws through the pipe flanges.
 - Install the rupture disk with a gasket on each side between the pipe flanges. Orient the disk with the reference arrow or vacuum support bar facing the chiller side as shown in the following figure (rupture disk location and cross section).
 - Install the two top hex head screws.

- Center the disk and gaskets to the flange bore.
- Hand-tighten all screws, assuring equal pressure.
- Use a torque wrench set to 240 in.·lb (27.1 N·m) with a 9/16-in. socket.
- Tighten screws in a star pattern, one half turn each, to maintain even pressure on the disk.
- Final torque on all screws should be 240 in.·lb (27.1 N·m).
- When attaching the vent line to the chiller, do NOT apply threading torque to the outside pipe of the rupture disk assembly.

NOTICE

Rupture Disk Damage!

Failure to follow instruction could result in damage to the rupture disk assembly.

Do not apply threading torque to the outside pipe.

- Provide support as needed for the vent line. Do NOT use the rupture disk assembly to support the vent-line piping.
- Use a flexible connection between the vent line and the rupture disk assembly to avoid placing stress on the rupture disk. (Stress can alter rupture pressure and cause the disk to break prematurely.) The flexible connector used to isolate the rupture disk from excessive vent line vibration must be compatible with the refrigerant in use. Use a flexible, steel connector (such as the stainless-steel type MFP, style HNE, flexible pump connector from Vibration Mounting and Control, Inc.), or equivalent. Refer to the following figure (arrangement for rupture disk relief piping) for a recommended relief piping arrangement.
- An individual vent line is normally installed for each relief device. It is permissible to manifold the rupture disks of several machines into a common vent line provided that the appropriate ASHRAE Standards and local code requirements for manifolded relief devices are followed.

Note: The following figure (arrangement for rupture disk relief piping) does NOT apply for manifolded vent lines.

⚠ WARNING

Pressure-Relief Device Discharge Hazard!

An improper vent-line termination could result in death or serious injury or equipment damage.

When a pressure-relief device operates, it could discharge a large amount of fluid and/or vapor. Units MUST be equipped with a vent-line termination that discharges outdoors in an area that will not spray refrigerant on anyone.

NOTICE

Proper Refrigerant Vent Line Termination!

Failure to properly terminate a refrigerant vent line could result in equipment damage.

Improperly terminating a refrigerant vent line could allow rain to enter the line. Accumulated rainwater could cause the relief device to malfunction; or, in the case of a rupture disk, the rainwater pressure could cause the disk to rupture, allowing water to enter the chiller.

- Route the vent-line piping so that it discharges outdoors in an area that will not spray refrigerant on anyone. Position the vent-line discharge at least 15 ft. (4.6 m) above grade level and at least 20 ft. (6.1 m) from any building opening. Provide a vent-line termination that cannot be blocked by debris or accumulate rainwater.
- Provide a drip leg on the vent line (see the following figure [arrangement for rupture disk relief piping]). Provide a standard 1/4-in. FL x 1/4-in. NPT, capped refrigerant service valve to facilitate liquid removal.

NOTICE

Equipment Damage!

Failure to follow instructions below could result in equipment damage.

All vent lines must be equipped with a drip leg of sufficient volume to hold the expected accumulation of water and/or refrigerant. The drip leg must be drained periodically to assure that it does not overflow and allow fluid to flow into the horizontal portion of the vent line. Trane assumes no responsibility for equipment damage caused by insufficient drainage of drip leg.

- Consult local regulations and codes for any additional relief line requirements and refer to appropriate refrigerant handling guidelines. For chillers with R-123 refrigerant, see *R-123 Low-Pressure Refrigerant Handling Guidelines Conservation and Safe Handling of R-123 Refrigerant in Trane Chillers for Service Technicians Installation, Operation, and Maintenance* (CTV-SVX05*-EN). For chillers with R-514A refrigerant, see *R-514A Low-Pressure Refrigerant Handling Guidelines Conservation and Safe Handling of R-514A Refrigerant in Trane Chillers for Service Technicians Installation, Operation, and Maintenance* (CTV-SVX008*-EN).

Figure 23. Rupture disk location and cross section of rupture disk

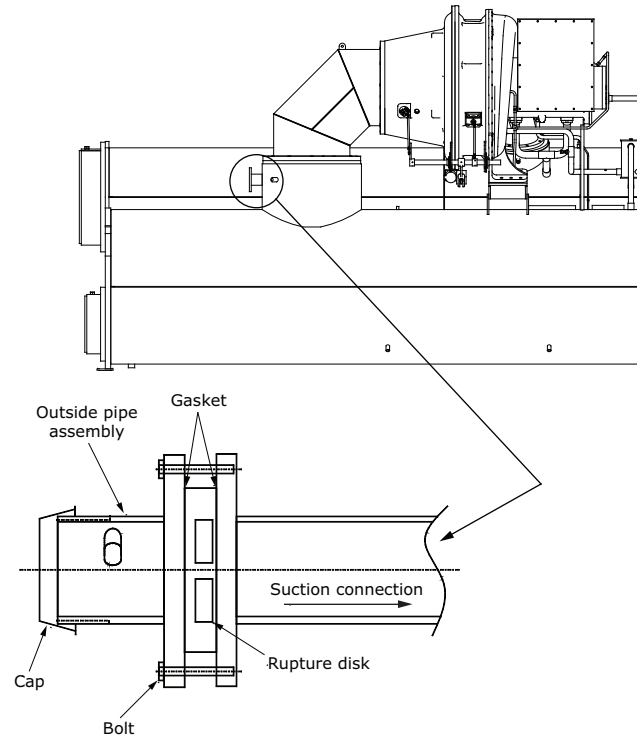

Note: Pipe connection is 3 in. (76.2 mm) NPT, except 250E evaporator/250L condenser units with heat recovery which have a 4 in. (101.6 mm) NPT pipe connection.

Figure 24. Arrangement for rupture disk relief piping

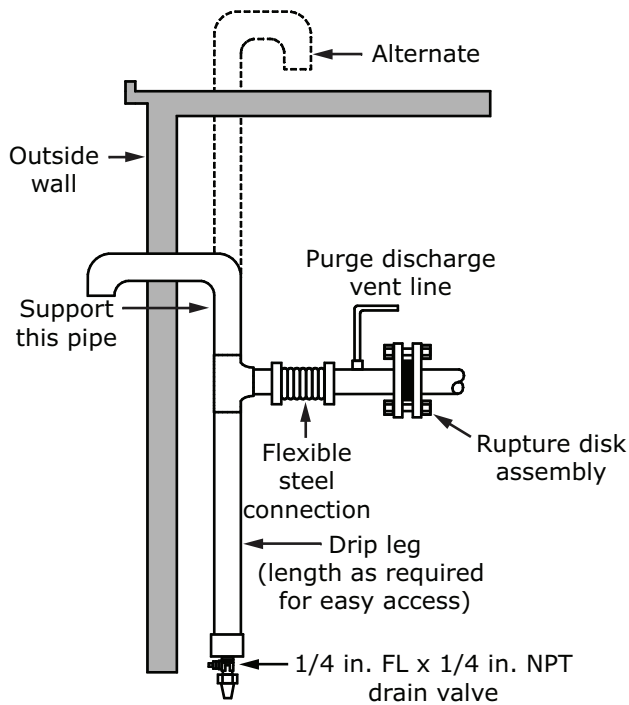

Important: On the purge discharge vent line, the purge exhaust connection point **MUST** be lower than the purge height. Do **NOT** create a U-trap; extend to drip leg if necessary to avoid a trap.

Note: The drip leg is **REQUIRED**. The drip leg should be a minimum of 1 gal (3.8 L) capacity and must be drained periodically for proper chiller purge operation.

Notes:

- If a RuptureGuard™ is to be installed, remove and discard the factory-installed rupture disk; for more information, refer to RuptureGuard™ Pressure Relief System Option For Use with Water-Cooled CenTraVac® Chillers Installation, Operation, and Maintenance (CTV-SVX06*-EN).
- The rated flow capacity of the RuptureGuard™ disk/valve assembly is based on having straight pipe extending past the spring mechanism downstream of the valve. Be sure there are no crosses (a derate on the rated flow capacity for this configuration is published in RuptureGuard Selection Guide Engineering Bulletin [E/CTV-EB-10]), elbows, tees or any other obstructions within the first 9 in. (228.6 mm) of valve discharge. Refer to ASHRAE Standard 15 for additional requirements on piping rupture disk and relief valve vent lines.

Figure 25. RuptureGuard external vent line and drip leg (not provided)

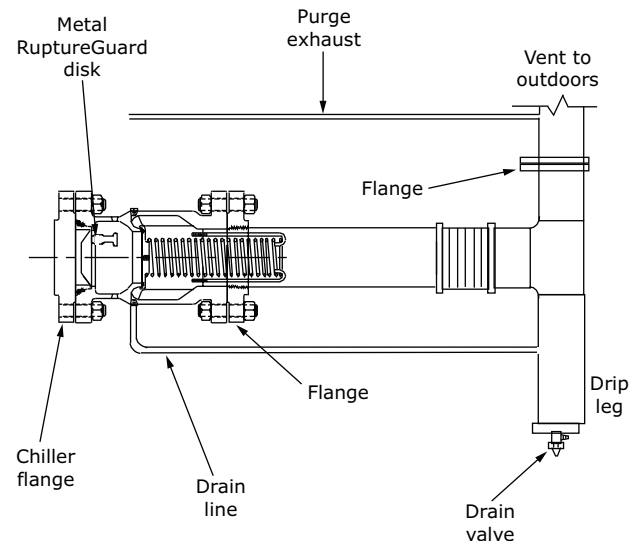

Important: The purge exhaust line **MUST** be connected to the downstream side piping to vent purge exhaust out the vent line to the outdoors; it may need to be extended to the drip leg. Field-acquired tubing may be required to extend to the field-supplied vent piping, depending on distance. Do **NOT** create a U-trap in the purge exhaust line; this line **MUST** be sloped from purge (highest point toward field-supplied piping, lower point toward connection) to allow proper draining of any condensation.

Notes:

- Use Loctite® 242 or Loctite® 277 on all threaded joints on chillers charged with refrigerant; use of other pipe thread sealants is **NOT** recommended. Ensure all threaded pipe joints are properly cleaned and prepared before assembly. An alternative to the use of Loctite® is to thread and weld the inlet adapter to the pipe. Care must be taken to ensure that the flange mating surface remains flat. Do **NOT** weld on the Inlet Adapter flange while connected to the RuptureGuard™.
- The drip leg is **REQUIRED**. The drip leg should be a minimum of 1 gal (3.8 L) capacity and must be drained periodically for proper chiller purge operation.

Important: If a RuptureGuard™ is to be installed, it **MUST** be installed properly. Failure to properly install RuptureGuard™ will likely result in a start-up delays and required rework and expenses that result from a failure to properly install RuptureGuard™ will **NOT** be paid by Trane.



Vent Line Sizing Reference

Table 15. "C" values used to determine rupture disk vent line sizes; for use with the following figure

Evap. Size (EVSZ)	Cond. Size (CDSZ)	"C" Values for Unit Components				
		Total "C" Value	Short H.R. Cond.	Long H.R. Cond.	Aux. Cond.	Free Cooling Econ.
032S	032S	50.00	18.87	25.19	15.30	3.66
032S	032L	61.32				
032L	032L	65.09				
050S	050S	64.20	23.55	31.45	15.30	5.50
050S	050L	72.10				
050L	050L	83.17				
050S	080S	69.71	N/A	N/A	N/A	N/A
050L	080L	90.52				
080S	080S	86.48	29.06	38.80	15.30	5.38
080S	080L	96.22				
080L	080L	111.50				
080L	142L	117.53	N/A	N/A	N/A	N/A
142M	142L	127.49	51.01	56.80	15.30	7.13
142L	142L	134.89				
142E	142L	143.11				
210L	210L	149.91	N/A	62.12	15.30	N/A
250E	250L	175.74				
210D	210D	112.93				
250D	250D	122.62	N/A	N/A	15.30	7.13
250M	250M	146.36			15.30	N/A
250X	250X	164.74			15.30	N/A

Notes:

- Rupture disk diameter is 3 in. (76.2 mm), with the exception of 250E evaporator/250L condenser units with heat recovery which have a rupture disk diameter of 4 in. (101.6 mm).
- To determine the total "C" value for a specific unit, add the appropriate "C" values for the evaporator, standard condenser, and economizer. If the unit is equipped with any options (e.g., heat recovery, free cooling, or an auxiliary condenser), add the applicable "C" values to this total. With this new sum, refer to the following figure to determine the vent-line pipe diameter.
- If piping multiple rupture disks to a common vent line, first determine the total "C" value for each rupture disk, then add all "C" values together and apply the result to the following figure.
- RuptureGuard™ size based on "C" value:
 3-in. (76.2 mm) valve: "C" value 0 to 104.20
 4-in. (101.6 mm) valve: C value 104.21 to 223.9
 RuptureGuard™ is not available for 250E evaporator/250L condenser units with heat recovery.

Figure 26. Rupture disk vent pipe sizing; for use with the preceding table

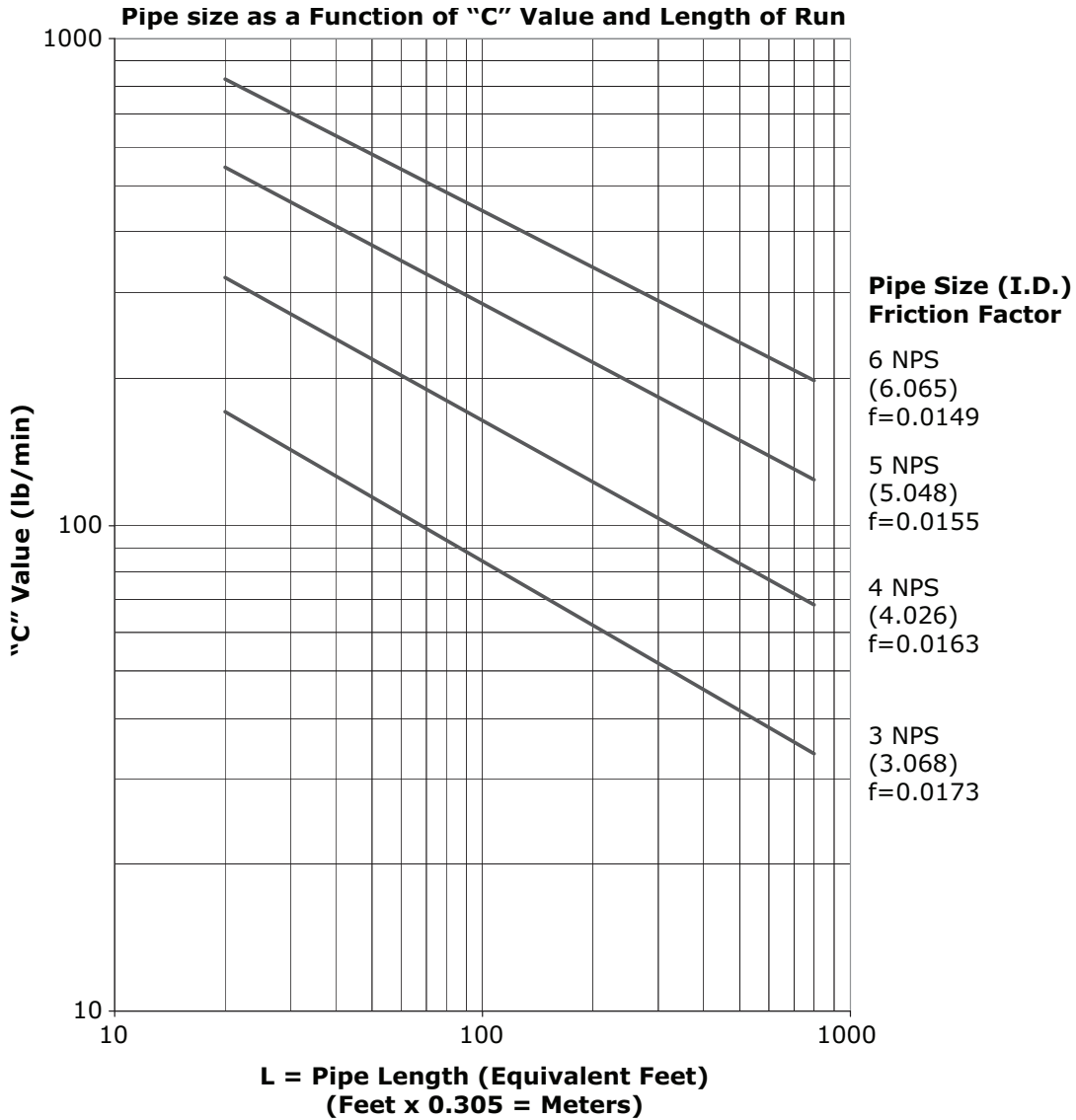

Note: The preceding figure, provided as a reference, is based on ASHRAE Standard 15. Vent line size is typically dictated by state or local code which may be different from ASHRAE Standard 15 requirements.

ASHRAE Standard 15

$$L = \frac{0.214d^5 (P_0^2 - P_2^2)}{fC_R^2} - \frac{d * \ln(P_0 / P_2)}{6f}$$

For CenTraVac® chillers using a rupture disk relief:

- L = equivalent length of discharge piping, ft (m)
- C_r = rated capacity as stamped on the relief device in lb/min (kg/s), or SCFM multiplied by 0.0764 lb/min (convert multiplier in lb/min to kg/s for SI)
 - $C_r = C$ value from the preceding table (convert C in lb/min to kg/s for SI)
- f = Moody friction factor in fully turbulent flow
- d = inside diameter of pipe or tube, in. (mm)
- \ln = natural logarithm
- P_2 = absolute pressure at outlet of discharge piping, psi (kPa)
- P_0 = allowed back pressure (absolute) at the outlet of pressure relief device, psi (kPa)
 - If chiller uses a rupture guard:
 $P_0 = (0.15 P) + \text{atmospheric pressure}$
 - If chiller uses a rupture disk:
 $P_0 = (0.5 P) + \text{atmospheric pressure}$

Note: On CenTraVac® chillers, P is 15 psi (6.8 kg). Atmospheric pressure is at the elevation of the installation above sea level; a default value is the atmospheric pressure at sea level, 14.7 psi (101.34 kPa).



Insulation

Unit Insulation Requirements

Factory-installed insulation is available as an option for all units. Factory installation does NOT include insulation of the chiller feet; if required, insulation for chiller feet is provided by others. In applications where the chiller is not factory-insulated, install insulation over the areas outlined and highlighted with dashed lines as shown in the figure in "Factory-applied Insulation," p. 47.

Insulate all 1/4-in. (6.35-mm) eductor lines, one from the suction cover and one from the evaporator, to prevent sweating.

The quantities of insulation required based on unit size and insulation thickness are listed in the following table. Insulation thickness is determined at normal design conditions which are:

- Standard comfort-cooling leaving chilled water temperature
- 85°F (29.4°C) dry bulb ambient temperature
- 75 percent relative humidity

Operation outside of normal design conditions as defined in this section may require additional insulation; contact Trane for further review.

Table 16. Evaporator insulation requirements

EVSZ ^(a)	Standard Unit		Free Cooling	
	3/4 in. (19.05 mm) ^(a) Insulation(Square Feet)	3/8 in. (9.525 mm) Insulation ^(b) (Square Feet)	3/4-in. (19.05 mm) Insulation ^(a) (Square Feet)	3/8 in. (9.525 mm) Insulation ^(b) (Square Feet)
032 Short	337	52	347	74
032 Long	365	52	377	74
050 Short	385	63	398	72
050 Long	420	63	436	72
080 Short	505	84	515	97
080 Long	553	84	566	97
142 Medium	555	98	555	133
142 Long	578	98	578	133
142 Extended	603	104	629	133
210 Long	700	98	710	133
250 Extended	770	97	780	133

Note: Chillers equipped with refrigerant pumps are NOT insulated on the motor or refrigerant drain lines.

^(a) 3/4-in. (19.05-mm) sheet insulation is installed on the evaporator, evaporator waterboxes, suction elbow, and suction cover.

^(b) 3/8-in. (9.525-mm) sheet insulation is installed on all economizers. All liquid lines and other pipes require the use of 1/2-in. (12.7-mm) pipe insulation or 3/8-in. (9.525-mm) sheet insulation. Copper oil eductor tube lines require pipe insulation.

Insulation Thickness Requirements

Factory-applied Insulation

All low-temperature surfaces are covered with 3/4-inch (19.05 mm) Armaflex® II or equal (thermal conductivity = 0.28 Btu/h-ft.² [1.59 W/m²-K]), including the evaporator,

Note: If the unit is not factory-insulated, install insulation around the evaporator bulbwells and ensure that the bulbwells and connections for the waterbox drains and vents are still accessible after insulation is applied. The sensor modules (Low Level Intelligent Devices [LLIDs]) and interconnecting four-wire cable inter-processor communication (IPC) bus must be raised up above the field-installed insulation. Secure the IPC bus to the insulation top/outer surface after insulation is completed.

Important: Do NOT insulate the motor housing, unit wiring, or sensor modules.

NOTICE

Equipment Damage!

Failure to remove the strain relief with the sensor could result in equipment damage.

Do NOT attempt to pull sensor bulb through the strain relief; always remove the entire strain relief with the sensor.

waterboxes, and suction elbow. The economizer and motor cooling lines are insulated with 3/8-inch (9.525 mm) and 1/2-inch (12.7 mm) insulation, respectively.

The insulation is Armaflex® or equivalent closed cell elastomeric insulation to prevent the formation of condensation up to a dew point rating of 74°F (23.3°C), K = 0.25. Chillers in high humidity areas or ice storage, low leaving water temperature (less than 36°F [2.2°C] chilled

Insulation

water temperature/glycol) units, may require double thickness to prevent formation of condensation.

NOTICE

Insulation Damage!

Failure to follow these instructions could result in insulation damage.

To prevent damage to factory installed insulation:

- Do not allow the insulation to be exposed to excessive sunlight. Store indoors or cover with canvas to prevent exposure.
- Do not use thinners and solvents or other types of paint. Use only water base latex.

Figure 27. Recommended area for unit insulation

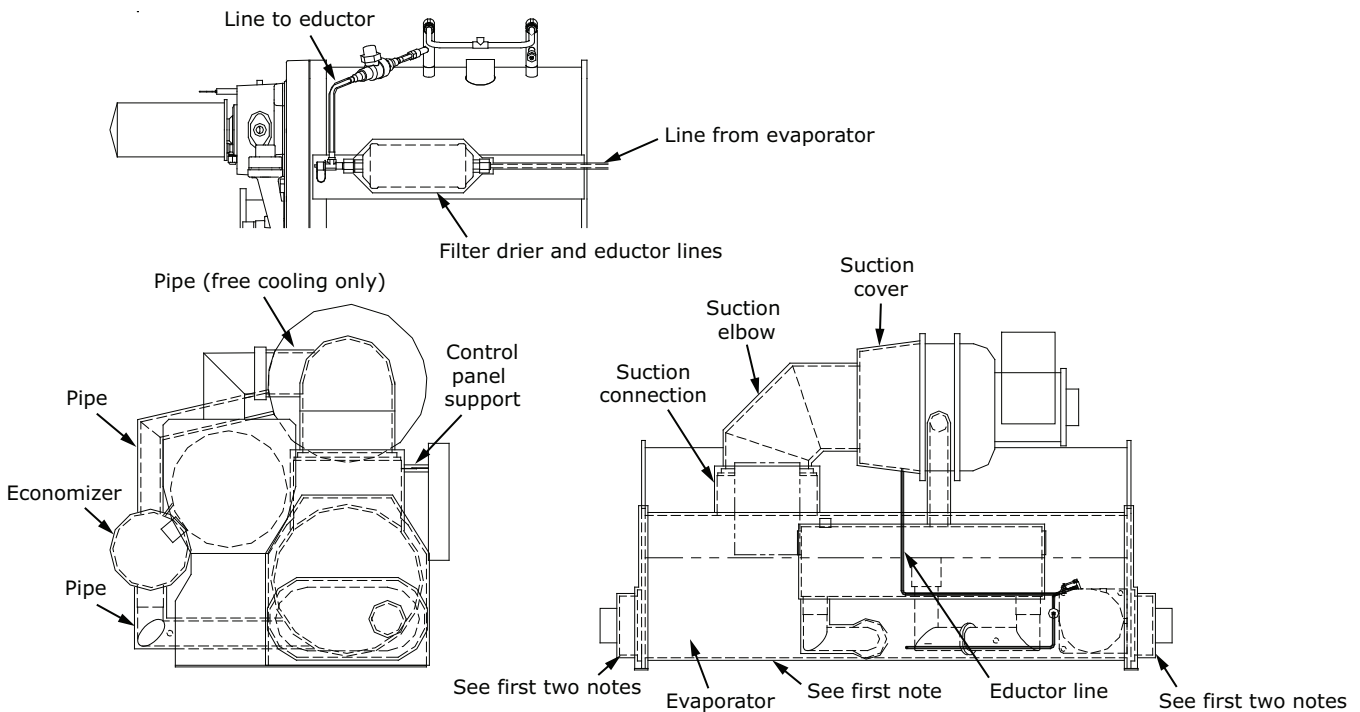

Notes:

- Bulbwells, drain, and vent connections must be accessible after insulating.
- All units with evaporator marine waterboxes: wrap waterbox shell insulation with strapping and secure strapping with seal.
- ASME nameplates must have insulation cut out around the nameplate. Do NOT glue insulation to the nameplate.
- Apply 2-in. (50.8-mm) wide black tape on overlap joints. Where possible, apply 3-in. (76.2-mm) wide strip of 0.38-in. (9.7-mm) thick insulation over butt joint seams.
- Insulate all economizer supports.



Installation: Controls

This section covers information pertaining to the Symbio 800 controller hardware. For information about the Tracer® AdaptiView display, which is used to interface with the internal chiller data and functions provided by the Symbio 800, see *AdaptiView™ Display with Symbio™ Controls CenTraVac® Water-Cooled Chillers User Guide* (CTV-SVU004*-EN).

Symbio™ 800

The Symbio 800 controller is a factory-installed, application specific and programmable controller designed to control chillers and large packaged HVAC equipment. A 12-inch user interface features a touch-sensitive color screen that provides facility managers at-a-glance operating status, performance monitoring, scheduling changes, and operating adjustments. Other advanced features include automated controller back-up, and optional features such as secure remote connectivity, wireless building communications, mobile device connectivity, and custom programming with an expandable I/O.

For more information, see *Symbio™ 800 Controller Installation, Operation, and Maintenance* (BAS-SVX080*-EN).

AdaptiView™ Display

Information is tailored to operators, service technicians, and owners. When operating a chiller, specific information is needed on a day-to-day basis — setpoints, limits, diagnostic information, and reports. This information is provided through the AdaptiView display. Logically organized groups of information — chiller modes of operation, active diagnostics, settings and reports put information conveniently at your fingertips.

For more information, see *AdaptiView™ Display with Symbio™ Controls CenTraVac® Water-Cooled Chillers, User Guide* (CTV-SVU004*-EN).

Tracer® TU

The AdaptiView TD12 operator interface allows for daily operational tasks and setpoint changes. However, to adequately service chillers, Tracer® TU service tool is required. (Non-Trane personnel, contact your local Trane office for software purchase information.) Tracer TU adds a level of sophistication that improves service technician effectiveness and minimizes chiller downtime. This portable PC-based service-tool software supports service

and maintenance tasks, and is required for software upgrades, configuration changes and major service tasks.

Tracer TU serves as a common interface to all Trane chillers, and will customize itself based on the properties of the chiller with which it is communicating. Thus, the service technician learns only one service interface.

The panel bus is easy to troubleshoot using LED sensor verification. Only the defective device is replaced. Tracer TU can communicate with individual devices or groups of devices.

All chiller status, machine configuration settings, customizable limits, and up to 100 active or historic diagnostics are displayed through the service-tool software interface.

LEDs and their respective Tracer TU indicators visually confirm the availability of each connected sensor, relay, and actuator.

Tracer TU is designed to run on a customer's laptop, connected to the Symbio™ 800 control panel with a USB cable. See *Tracer® TU Service Tool User Guide* (BAS-SVU046*-EN) for laptop requirements.

Notes:

- *Tracer TU is designed and validated for this minimum laptop configuration. Any variation from this configuration may have different results. Therefore, support for Tracer TU is limited to only those laptops with the configuration previously specified.*
- *For more information, see *Tracer® TU Service Tool User Guide* (BAS-SVU046*-EN).*

Figure 28. Tracer TU

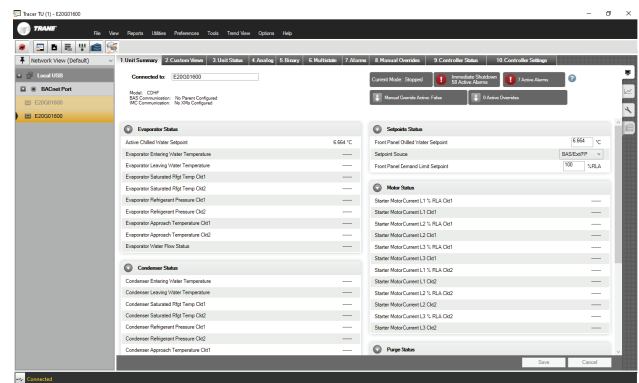



Control Panel

Figure 29. Standard control panel: main unit assembly (showing low voltage and higher voltage areas for proper routing of field wiring)

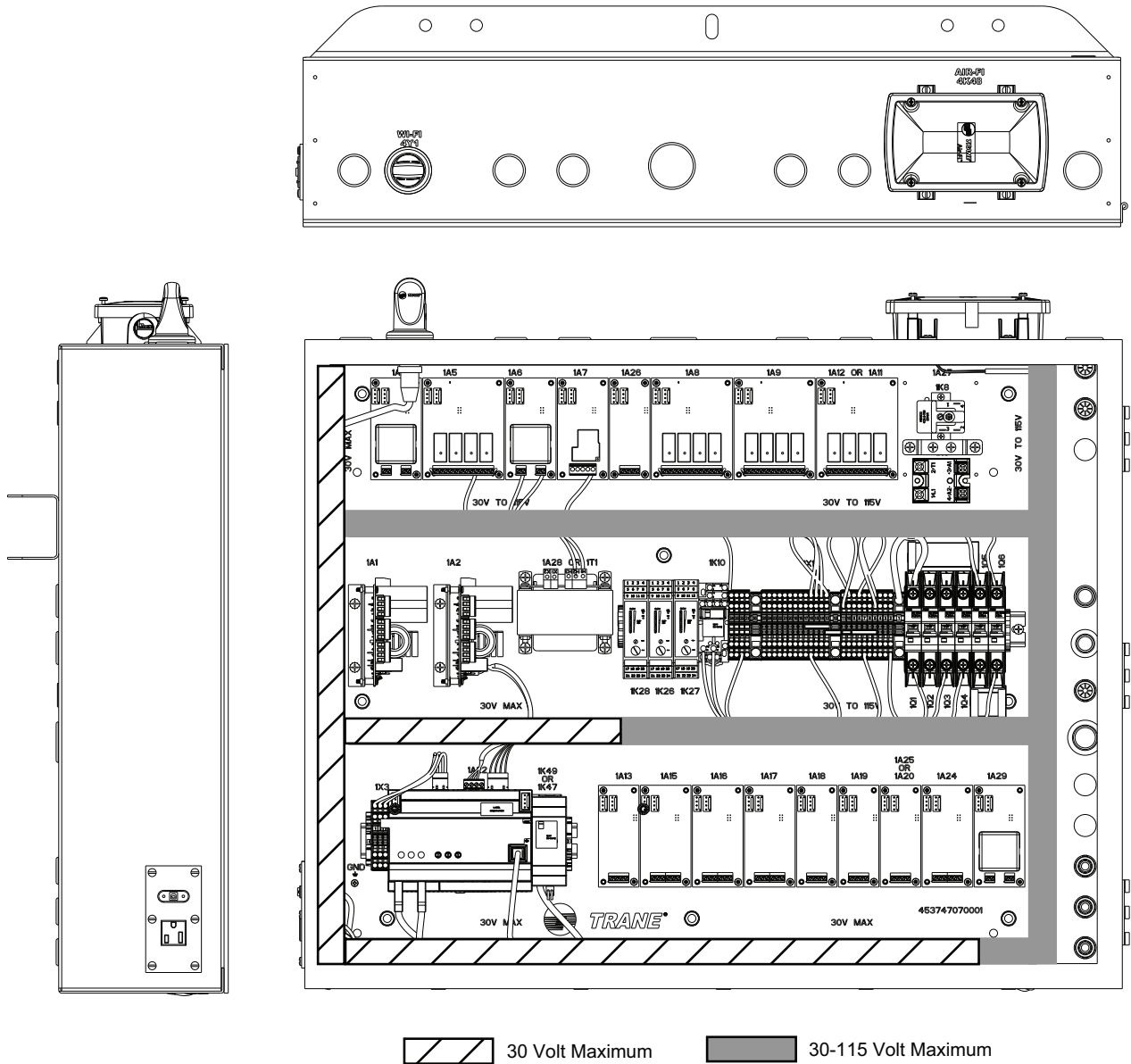
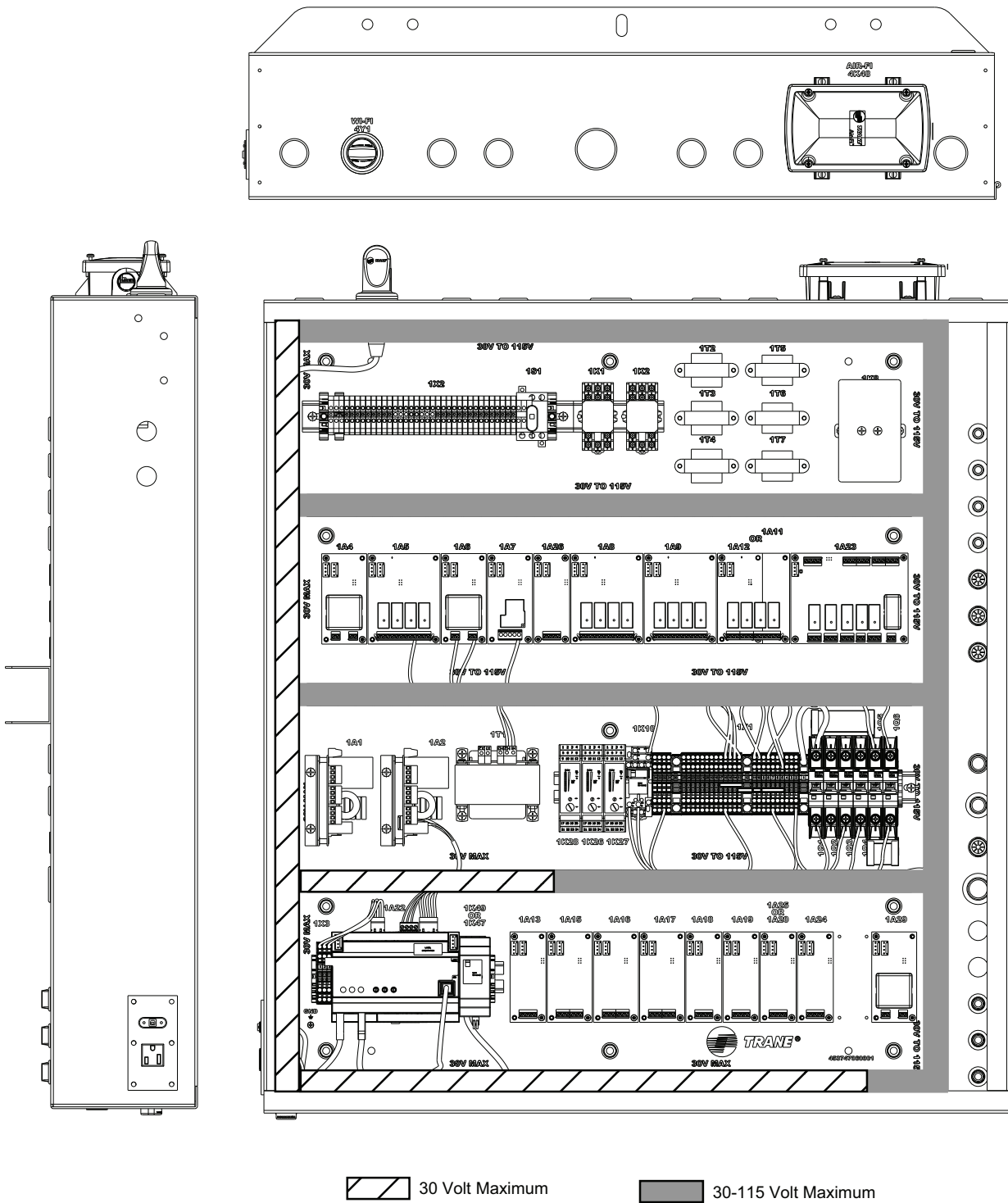

Figure 30. Optional control panel: main unit assembly (showing low voltage and higher voltage areas for proper routing of field wiring)



Installing the Tracer AdaptiView Display

During shipment, the Tracer AdaptiView display is boxed, shrink-wrapped, and located behind the control panel. The display must be installed at the site.

Important: For best results, Trane, or an agent of Trane, must install the Tracer AdaptiView display and support arm.

1. Unwrap the control panel and display arm. Locate the box containing the Tracer® AdaptiView™ display behind the control panel (labeled A in the following figure).
2. After the box containing the display has been removed, remove the shipping bracket from the back of the control panel (labeled B in the following figure).
3. Remove the display from the box.

Note: Display screws are M4 (metric size 4), 6 to 8 mm long, and are shipped with the display.

4. Plug the power cable (labeled C in the following figure) and the Ethernet cable (labeled D in the following figure) into the bottom of the display.

Note: Both cables are already present and extend from the end of the display arm.

5. Adjust the Tracer AdaptiView display support arm so the base plate that attaches to the display is horizontal.

⚠ CAUTION

Tension in Display Support Arm!

Failure to follow instructions below could result in unexpected movement of the spring-loaded support arm which could result in minor to moderate injury.

Ensure that the support arm is in the full upright position when removing the Tracer AdaptiView display from the support arm.

Note: Review “Adjusting the Tracer® AdaptiView™ Display Arm,” p. 53 before attaching the display as some adjustments may be required prior to attaching the display to the support arm base.

6. Position the Tracer AdaptiView display—with the LCD screen facing up—on top of the display support arm base plate.

Note: Ensure the Trane logo is positioned so that it will be at the top when the display is attached to the display support arm.

Important: Use care when positioning the Tracer AdaptiView display on top of the support arm base plate and do NOT drop the display.

7. Align the four holes in the display with the screw holes in the display support arm base plate.
8. Attach the Tracer AdaptiView display to the display support arm base plate (labeled E in the following

figure) using the M4 (metric size 4) screws referenced in Step 3.

Figure 31. Tracer AdaptiView shipping location

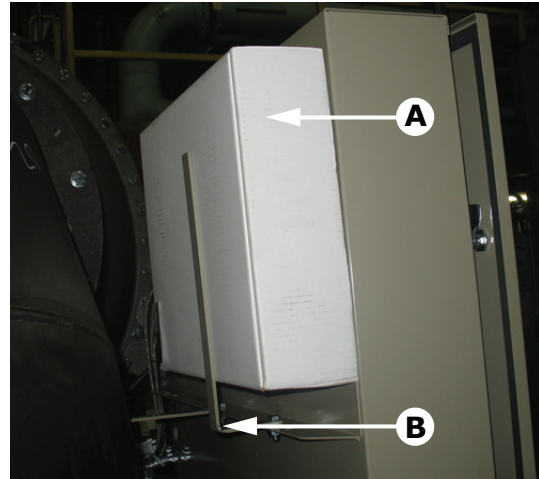

Figure 32. Power cable and ethernet cable connections

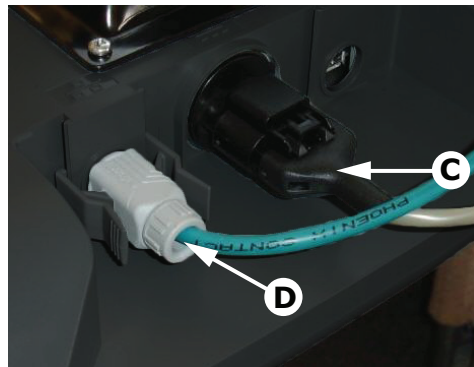
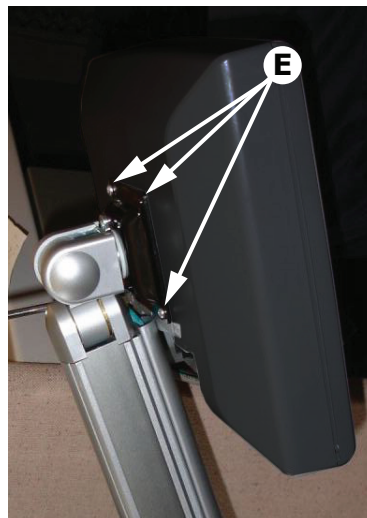

Figure 33. Display attachments to the support arm base plate



Adjusting the Tracer® AdaptiView™ Display Arm

The Tracer® AdaptiView™ display arm may become too loose or too tight and may need adjustment. There are three joints on the display arm that allow the display to be positioned at a variety of heights and angles (refer to items labeled **1**, **2**, and **3** in the following figure).

Figure 34. Joint locations on the display arm

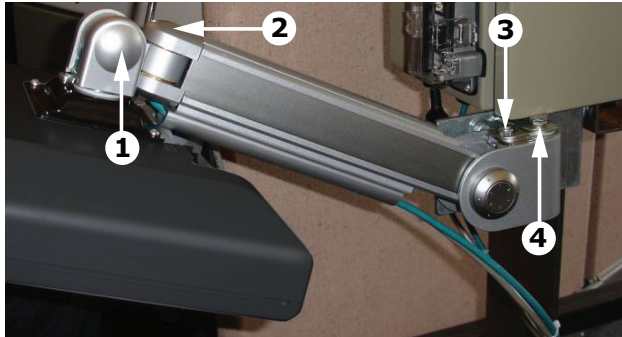

To adjust the tension on the display arm:

- At each joint in the display arm, there is either a hex bolt (**1** and **2**) or hex screw (**3**). Turn the hex bolt or screw in the proper direction to increase or decrease tension.

Note: Each hex bolt or screw is labeled with **loosen/tighten** or **+/-** indicators.

- Joint **3** has a 6 mm hex screw controlling the tension on a gas spring, which allows the Tracer® AdaptiView™ display to tilt up and down.
- Joints **1** and **2** are covered by a plastic cap. Remove the plastic cap to access the screw. Adjust using a 13 mm wrench as necessary.
- To adjust the swivel rotation tension of the Tracer® AdaptiView™ display, adjust the screw located in the support arm base plate, as described in the final step in the Installing the Tracer® AdaptiView™ Display section.. *This adjustment must be done prior to attaching the display to the support arm base.* Use a 14 mm wrench to adjust the tension.
- To adjust the left/right swivel of the entire display arm, use a 13 mm wrench to adjust the screw labeled **4** in the preceding figure.

Module Installation

Air-Fi®

For installation instructions, see *Air-Fi® Wireless Communications Interface (WCI) Installation Instructions (BAS-SVN038*-EN)*.

Recommended routing path for supplied Air-Fi cable is shown in figure below. Device may be remote mounted in order to obtain a stronger signal.



Installation: Controls

Figure 35. Air-Fi® wire harness routing path

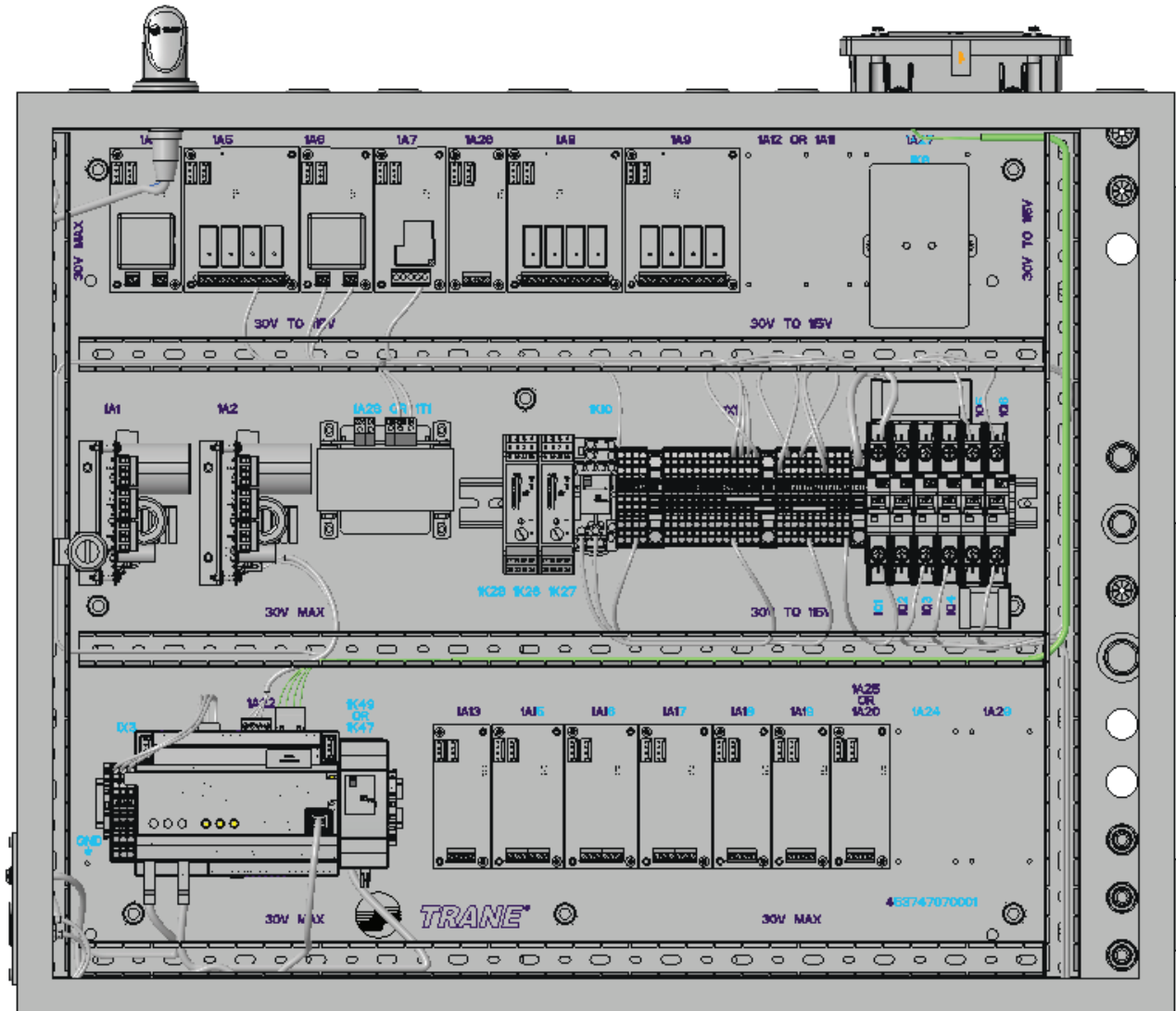

Wi-Fi

For installation instructions, see *Trane® Wi-Fi Module Installation Instructions* (BAS-SVN042*-EN).

Recommended routing path for supplied Wi-Fi cable is shown in figure below. Device may be remote mounted in order to obtain a stronger signal.

Figure 36. Wi-Fi wire harness routing path

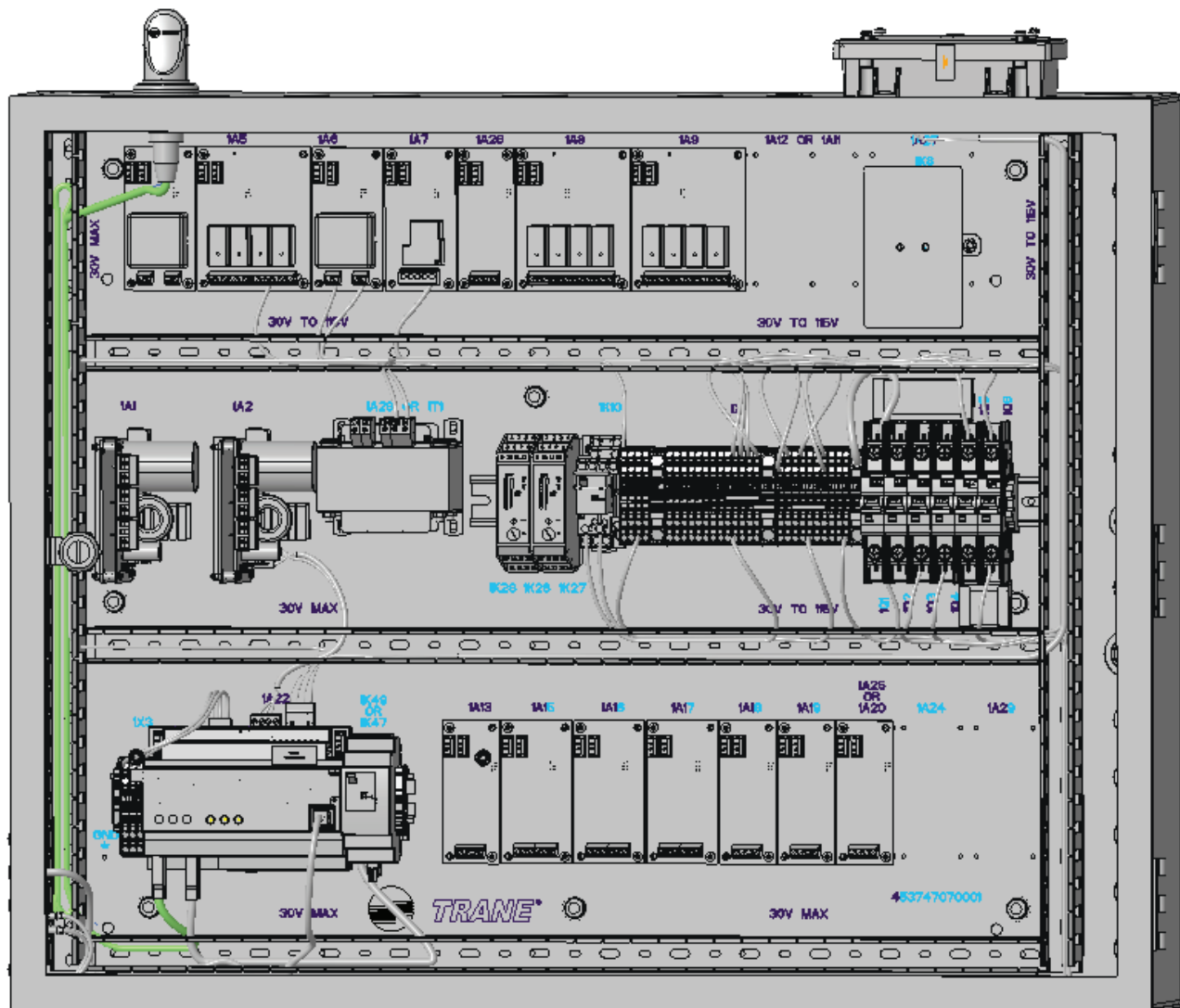



Installation: Electrical

Important: For units sold in the United States, field provisions shall be made to ensure the unit is in compliance with NEC/NFPA70 when the disconnect height exceeds 2 meters.

Installation Requirements

⚠ WARNING

Proper Field Wiring and Grounding Required!

Failure to follow code could result in death or serious injury.

All field wiring **MUST** be performed by qualified personnel. Improperly installed and grounded field wiring poses **FIRE** and **ELECTROCUTION** hazards. To avoid these hazards, you **MUST** follow requirements for field wiring installation and grounding as described in **NEC** and your local/state/national electrical codes.

Unit-mounted starters are available as an option on most units. While this option eliminates most field-installed wiring requirements, the electrical contractor must still complete the electrical connection for the following:

- Power supply wiring to the starter
- Other unit control options present
- Any field-supplied control devices

As you review this manual along with the wiring instructions presented in this section, keep in mind that:

- All field-installed wiring must conform to National Electric Code (NEC) guidelines, and any applicable local, state, and national codes. Be sure to satisfy proper equipment grounding requirements per NEC.
- Compressor motor and unit electrical data (including motor kW, voltage utilization range, rated load amps, and locked rotor amps) is listed on the chiller nameplate.
- All field-installed wiring must be checked for proper terminations, and for possible shorts or grounds.

Note: Always refer to the actual wiring diagrams that shipped with the chiller or the unit submittal for specific as-built electrical schematic and connection information.

NOTICE

Adaptive Frequency Drive (AFD)/Starter Component Damage!

Failure to remove debris from inside the AFD/starter panel could result in an electrical short and could cause serious AFD/starter component damage.

Do NOT modify or cut enclosure to provide electrical access. Removable panels have been provided, and any

modification should be done away from the enclosure. If the starter enclosure must be cut to provide electrical access, exercise care to prevent debris from falling inside the enclosure. Refer to installation information shipped with the starter or submittal drawings.

Electrical Requirements

Before wiring begins, observe the following electrical requirements:

- Follow all lockout/tagout procedures prior to performing installation and/or service on the unit.
- Always wear appropriate personal protective equipment.
- Wait the required time to allow the capacitor(s) to discharge; this could be up to 30 minutes.
- Verify that all capacitors are discharged prior to service using a properly rated volt meter.
- Use appropriate capacitor discharge tool when necessary.

⚠ WARNING

Hazardous Voltage w/Capacitors!

Failure to disconnect power and discharge capacitors before servicing could result in death or serious injury.

Disconnect all electric power, including remote disconnects and discharge all motor start/run capacitors before servicing. Follow proper lockout/tagout procedures to ensure the power cannot be inadvertently energized. For variable frequency drives or other energy storing components provided by Trane or others, refer to the appropriate manufacturer's literature for allowable waiting periods for discharge of capacitors. Verify with a CAT III or IV voltmeter rated per NFPA 70E that all capacitors have discharged.

⚠ WARNING

Personal Protective Equipment (PPE) Required!

Failure to wear PPE and follow proper handling guidelines could result in death or serious injury. Always wear appropriate personal protective equipment in accordance with applicable regulations and/or standards to guard against potential electrical shock and flash hazards.

⚠ WARNING

Live Electrical Components!

Failure to follow all electrical safety precautions when exposed to live electrical components could result in death or serious injury.

When it is necessary to work with live electrical components, have a qualified licensed electrician or other individual who has been properly trained in handling live electrical components perform these tasks.

Trane-supplied Starter Wiring

Table 17. Standard field power wiring requirements

Power Supply Wiring to Starter Panel	Starter Panel Terminals	—	—	—
3-Phase Line Voltage	2X3-L1, L2, L3, and Ground ^(a)	—	—	—
3-Phase Line Voltage: Circuit Breaker	2Q1-L1, L2, L3, and Ground	—	—	—
Starter to Motor Power Wiring	Starter	Motor	—	—
Remote Starter to Chiller Motor Junction Box	T1 through T6	T1 through T6	—	—
Starter to Control Panel 120 Vac Control Wiring	Starter Panel Terminals	Unit Control Panel Terminations	Max Terminal Wire Size (AWG) ^(b)	Minimum Circuit Ampacity
120 Vac Power Supply (from Starter to Control Panel)	2X1-1, 2X1-2 2X1-G (Ground)	1X1-1, 1X1-12 1X1-30 (Ground)	8	40
High Pressure Cutout to Starter	2X1-4	1X1-4	14	20
1Q1 Circuit Breaker to Starter	^(c)	1X1-3	14	20
Oil Pump Interlock	2X1-7, 2X1-8	1A7-J2-4, 1A7-J2-2	14	20
Low Voltage Circuits Less Than 30 Vac	Starter Panel Terminals	Unit Control Panel Terminations	—	—
Standard Circuits	—	—	—	—
Inter-processor Communications (IPC) Remote-Mounted ^{(d)(e)}	2A1-J3-3-4, or 2X1-12 to 13 if Present (Do NOT Ground Shield at Starter)	1A1-J5-1-2, 3-4 Shield Ground at 1X1-34 (GND) Only	2-wire with Ground Comm Link	—

Notes:

1. All wiring to be in accordance with National Electrical Code (NEC) and any local codes.
 2. Oil pump motor: 1 Ph, 3/4 HP, 11.7 full load amps at 115 Vac.
 3. Auxiliary equipment must be powered from other sources as the chiller control panel power supplies are sized for the chiller loads only.
- ^(a) Ground lug for a unit-mounted solid state starter or wye-delta starter is sized to accept 14 AWG solid to 8 AWG strand wire. If local codes require different lug size, it must be field-supplied and -installed.
- ^(b) Wires, lugs, and fuses/breakers are sized based on National Electric Code NEC [NFPA 70] and UL 60335-2-40.
- ^(c) 1Q1 Circuit Breaker to Starter connects to 2X16 Starter Panel Terminal for all starter types *except* the AFDG (Trane-supplied remote Danfoss AFD); for the AFDG, 1Q1 Circuit Breaker to Starter connects to 2X13 Starter Panel Terminal.
- ^(d) Must be separated from 120 Vac and higher wiring.
- ^(e) The maximum distance a Trane-supplied remote starter can be placed from the chiller is 1000 ft. (305 m).

Note: Control Power Transformer (CPTR, Enhanced Electrical Protection Package option): A unit-mounted, factory-wired, separate enclosure positioned next to the control panel is available when separate source control power is required. This permits the controls to remain powered while the three-phase line voltage is disconnected. Contact your local Trane representative for more information.



Customer-supplied Remote Starter Wiring

Table 18. Standard customer-supplied remote field wiring requirements

Power Supply Wiring to Starter Panel	Starter Panel Terminals	—	—	—
Starter by Others 3-phase Power Wiring	See Starter by Others Schematic	—	—	—
Starter to Motor Power Wiring	Starters	Motor	—	—
Remote Starter to Chiller Motor Junction Box	T1 through T6 Terminals	T1 through T6 Terminals	—	—
Starter to Control Panel 120 Vac Control Wiring	Starter Panel Terminals	Unit Control Panel Terminations	Max Terminal Wire Size (AWG) ^(a)	Minimum Circuit Ampacity
120 Vac Power Supply (from Starter to Control Panel)	See Starter by Others Schematic 5X1-1, 5X1-2, 5X1-G (Ground)	1X1-1, 1X1-12, 1X1-30 (Ground)	8	40
Power from Control Panel 1Q1	5X1-3	1X1-2	14	20
Interlock Relay Signal	5X1-4	1A23-J10-1	14	20
Start Contactor Signal	5X1-5	1A23-J8-1	14	20
Oil Pump Interlock	5X1-7, 5X1-8	1A7-J2-4, 1A7-J2-2	14	20
Run Contactor Signal	5X1-10	1A23-J6-1	14	20
Transition Complete	5X1-14	1A23-J12-2	14	20
Low Voltage Circuits Less than 30 Vac	Starter Panel Terminals	Unit Control Panel Terminations	—	—
Standard Circuits	—	—	—	—
Current Transformers (see table in "Current Transformer and Potential Transformer Wire Sizing," p. 58) (Required) ^(b)	5CT4-white, black 5CT5-white, black 5CT6-white, black	1A23-J7-1,2 1A23-J7-3,4 1A23-J7-5,6	Note: Phasing must be maintained.	—
Potential Transformers (Required)	5T17-236,237 5T18-238,239 5T19-240,241	1A23-J5-1,2 1A23-J5-3,4 1A23-J5-5,6	Note: Phasing must be maintained.	—
Solid State Starter Fault ^(c)	5X1-11 5X1-12	1A24-J2-1 1A24-J2-2	—	—

Notes:

- All wiring to be in accordance with National Electrical Code (NEC) and any local codes.
- Starter by Others Specification available from your local Trane sales office.

^(a) Wires, lugs, and fuses/breakers are sized based on National Electric Code (NEC) [NFPA 70] and UL 60335-2-40.
^(b) Must be separated from 120 Vac and higher wiring.
^(c) Solid State Starter Fault input is used with low- and medium-voltage, customer-supplied solid state starters only.

Current Transformer and Potential Transformer Wire Sizing

For customer-supplied starter-to-chiller unit control panel starter module 1A23; these wires must be separated from 120 Vac or higher wiring.

Table 19. Maximum recommended wire length for secondary current transformer (CT) leads in dual CT system

Wire AWG ^(a)	Maximum Wire Length Secondary CT Leads	
	Feet	Meters
8	1362.8	415.5
10	856.9	261.2
12	538.9	164.3
14	338.9	103.3
16	213.1	65.0
17	169.1	51.5
18	134.1	40.9
20	84.3	25.7

Notes:

- Wire length is for copper conductors only.
- Wire length is total one-way distance that the CT can be from the starter module.

^(a) Wires, lugs, and fuses/breakers are sized based on National Electric Code (NEC) [NFPA 70] and UL 60335-2-40.

Table 20. Maximum recommended total wire length for potential transformers (PTs) in a single PT system

Wire AWG ^(a)	Maximum Lead Length	
	Feet	Meters
8	5339	1627
10	3357	1023
12	2112	643
14	1328	404
16	835	254
17	662	201
18	525	160
20	330	100
21	262	79
22	207	63

Notes:

1. Wire length is for copper conductors only.
2. Wire length is maximum round trip wire length. The maximum distance the PT can be located from the starter module is half of the listed value.

^(a) Wires, lugs, and fuses/breakers are sized based on National Electric Code (NEC) [NFPA 70] and UL 60335-2-40.

Table 21. Maximum recommended total wire length (to and from) for PT leads in a dual PT system

Wire AWG ^(a)	Max Wire Length Primary		Max Wire Length Secondary	
	Feet	Meters	Feet	Meters
8	3061	933	711	217
10	1924	586	447	136
12	1211	369	281	85
14	761	232	177	53
16	478	145	111	33
17	379	115	88	26
18	301	91	70	21
20	189	57	44	13
21	150	45	34	10
22	119	36	27	8

Notes:

1. Wire length is for copper conductors only.
2. Wire length is maximum round trip wire length. The maximum distance the PT can be located from the starter module is half of the listed value.

^(a) Wires, lugs, and fuses/breakers are sized based on National Electric Code (NEC) [NFPA 70] and UL 60335-2-40.

Power Supply Wiring

⚠ WARNING

Proper Field Wiring and Grounding Required!

Failure to follow code could result in death or serious injury.

All field wiring **MUST** be performed by qualified personnel. Improperly installed and grounded field wiring poses **FIRE** and **ELECTROCUTION** hazards. To avoid these hazards, you **MUST** follow requirements for field wiring installation and grounding as described in NEC and your local/state/national electrical codes.

Three-Phase Power

Review and follow the guidelines in this section to properly install and connect the power supply wiring to the starter panel:

- Verify that the starter nameplate ratings are compatible with the power supply characteristics and with the electrical data on the unit nameplate.

NOTICE

Adaptive Frequency Drive (AFD)/Starter Component Damage!

Failure to remove debris from inside the AFD/starter panel could result in an electrical short and could cause serious AFD/starter component damage.

NOTICE

Use Copper Conductors Only!

Failure to use copper conductors could result in equipment damage as the equipment was not designed or qualified to accept other types of conductors.

- Do NOT modify or cut enclosure to provide electrical access. Removable panels have been provided and any modification should be done away from the enclosure. If the starter enclosure must be cut to provide electrical access, exercise care to prevent debris from falling inside the enclosure.
- Use copper conductors to connect the three-phase power supply to the remote- or unit-mounted starter panel.
- Flexible conduit connections are recommended to enhance serviceability and minimize vibration transmission.
- Size the power supply wiring in accordance with National Electric Code (NEC), using the RLA value stamped on the chiller nameplate and transformer load on L1 and L2.

- Confirm that wire size is compatible with lug size stated in unit submittal.
- Make sure that the incoming power wiring is properly phased; each power supply conduit run to the starter must carry the correct number of conductors to ensure equal phase representation.

Note: Connect L1, L2, and L3 (shown in the following figure) per starter diagram provided with chiller.

- When installing the power supply conduit, ensure that the position of the conduit does not interfere with the serviceability of any of the unit components, or with structural members and equipment. Ensure that the conduit is long enough to simplify any servicing that may be necessary in the future (e.g., starter).
- Electrical wire torque specifications — follow starter manufacturers torque specifications.

Figure 37. Proper phasing for starter power supply wiring

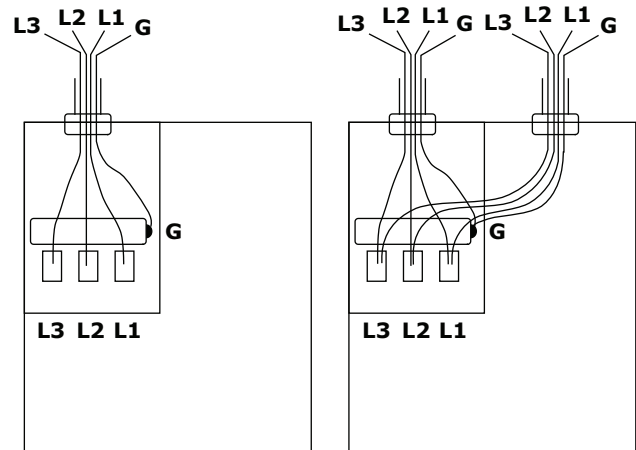

Circuit Breakers and Fused Disconnects

Any field-supplied circuit breaker or fused disconnect installed in power supplied to the chiller must be sized in compliance with National Electric Code (NEC) or local guidelines.

Power Factor Correction Capacitors (Optional)

Power factor correction capacitors (PFCCs) are designed to provide power factor correction for the compressor motor. PFCCs are available as an option for unit- and remote-mounted starters.

Notes:

- Verify PFCC voltage rating is greater than or equal to the compressor voltage rating stamped on the unit nameplate.
- Refer to the wiring diagrams that shipped with the unit for specific PFCC wiring information.

NOTICE

Motor Damage!

Failure to wire PFCCs into the starter correctly could cause misapplication of these capacitors and result in a loss of motor overload protection and subsequently cause motor damage.

PFCCs must be wired one of two ways as shown as explained in the following figures and accompanying text (Option 1 and Option 2).

Figure 38. Option 1 — PFCCs installed downstream of starter contactor, upstream of current transformers

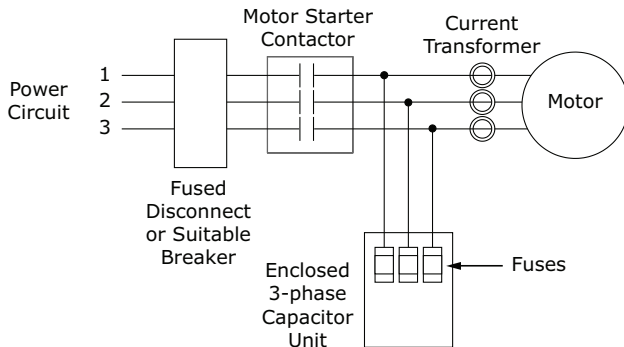

⚠ WARNING

Hazardous Voltage w/Capacitors!

Failure to disconnect power and discharge capacitors before servicing could result in death or serious injury.

Disconnect all electric power, including remote disconnects and discharge all motor start/run capacitors before servicing. Follow proper lockout/tagout procedures to ensure the power cannot be inadvertently energized. For variable frequency drives or other energy storing components provided by Trane or others, refer to the appropriate manufacturer's literature for allowable waiting periods for discharge of capacitors. Verify with a CAT III or IV voltmeter rated per NFPA 70E that all capacitors have discharged.

Simultaneously disconnect capacitors and load from line power. If the capacitors are not switched offline when the load is disconnected, they continue to add capacitance to the electrical distribution system. A *leading* power factor and too much capacitance may eventually develop. This overprotection causes poor voltage regulation (i.e., voltage is high when the circuit is unloaded, then drops as loads are added).

Figure 39. Option 2—PFCC wires routed through current transformers

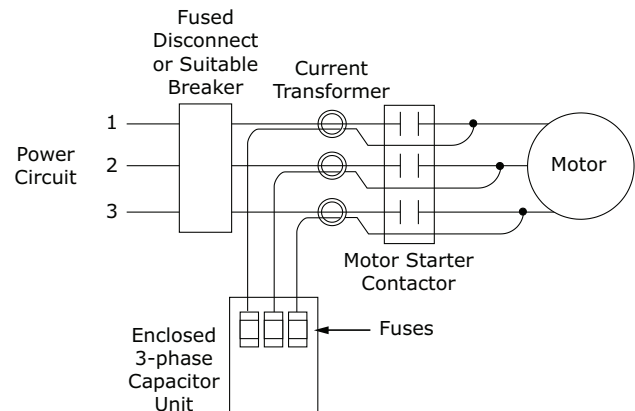

Size motor overload protection to account for capacitor-supplied current. Overloads are typically set to measure the total current drawn by the motor. When PFCCs are used, they become the source of part of that current. If the current they provide is not registered by the overload protectors, potentially damaging amperage can reach the motor. The simplest way to ensure that the overloads detect all current supplied to the motor is to position the PFCCs upstream of the current transformers as shown in the preceding figure (Option 1). If the capacitor connection points are downstream of the current transformers, route the PFCC leads through the current transformers as shown in the preceding figure (Option 2). This ensures that the overloads register both line and capacitor-supplied current.

Interconnecting Wiring

Typical equipment room conduit layouts with and without unit-mounted starters are shown in the following two figures.

Important: *The interconnecting wiring between the starter panel, compressor, and control panel is factory-installed with unit-mounted starters. However, when a remote-mounted starter is used, the interconnecting wiring must be field-installed.*

Note: *Refer to starter submittal drawing for location of incoming wiring to the starter.*

Figure 40. Typical equipment room layout for units with unit-mounted starters

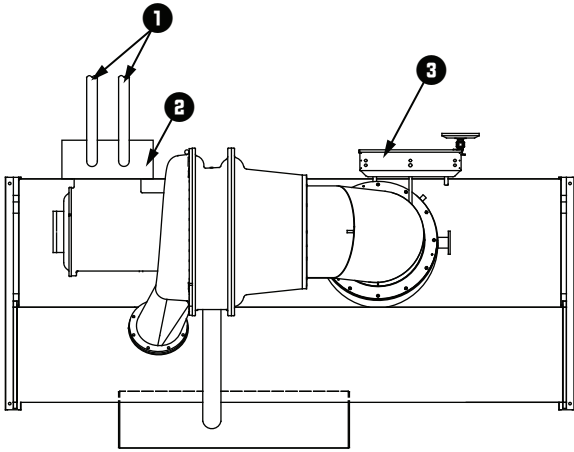

1. Line side power conduits
2. Unit-mounted starter
3. Unit control panel

Figure 41. Typical equipment room layout for units with remote-mounted starters

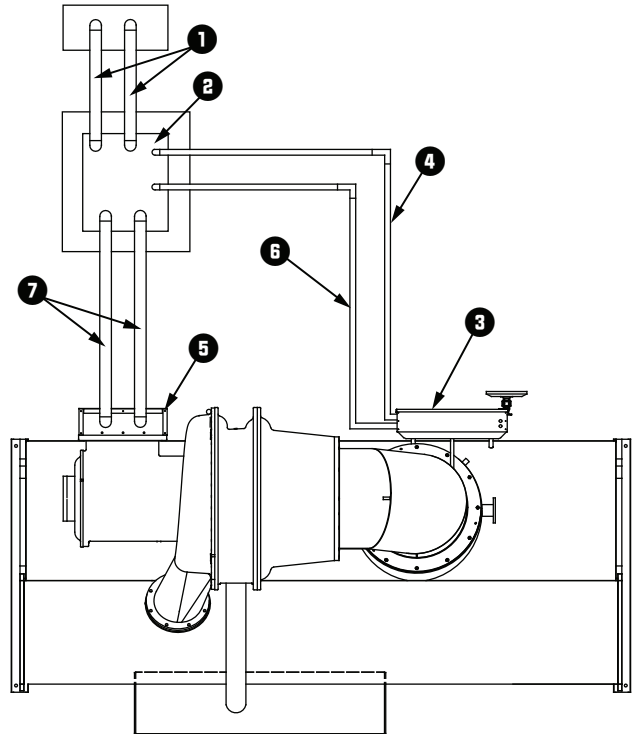

1. Line side power conduits
2. Remote-mounted starter
3. Unit control panel
4. Inter-processor communication (IPC) circuit conduit less than 30V (and current transformer/potential transformer [CT/PT] wiring for starters by others)

Note: Must enter the low voltage Class 2 portion of the unit control panel (1000 feet [304.8 m] maximum).

5. Motor terminal box
6. 115V control conduit

Note: Must enter the higher than 30 Vdc Class 1 portion of the unit control panel.

7. Lead power wiring

Note: Refer to the unit field connection diagram for approximate unit control panel knock out locations. To prevent damage to the unit control panel components, do NOT route control conduit into the top of the box.

Starter to Motor Wiring (Remote-Mounted Starters Only)

Ground Wire Terminal Lugs

Ground wire lugs are provided in the motor terminal box and in the starter panel.

Terminal Clamps

NOTICE

Use Copper Conductors Only!

Failure to use copper conductors could result in equipment damage as the equipment was not designed or qualified to accept other types of conductors.

Terminal clamps are supplied with the motor terminals to accommodate either bus bars or standard motor terminal wire lugs. Terminal clamps provide additional surface area to minimize the possibility of improper electrical connections.

Wire Terminal Lugs

NOTICE

Component Damage!

Failure to ensure the power supply wiring and output to motor wiring are connected to the proper terminals could cause catastrophic failure of the starter and/or motor.

Wire terminal lugs must be field supplied.

- Use field-provided, crimp-type wire terminal lugs properly sized for the application.

Note: Wire size ranges for the starter line and load-side lugs are listed on the starter submittal drawings supplied by the starter manufacturer or Trane. Carefully review the submitted wire lug sizes for compatibility with the conductor sizes specified by the electrical engineer or contractor.
- On 4160V and below, a terminal clamp with a 3/8-in. (9.525-mm) bolt is provided on each motor terminal stud; use the factory-supplied Belleville washers on the wire lug connections. The following figure illustrates the junction between a motor terminal stud and terminal lug.
- Torque for this assembly is 24 ft·lb (32.5 N·m).
- Install but do NOT connect the power leads between the starter and compressor motor. (These connections will be completed under supervision of a qualified Trane service engineer after the pre-start inspection.)

Figure 42. Terminal stud, clamp, and lug assembly (4160V and below)

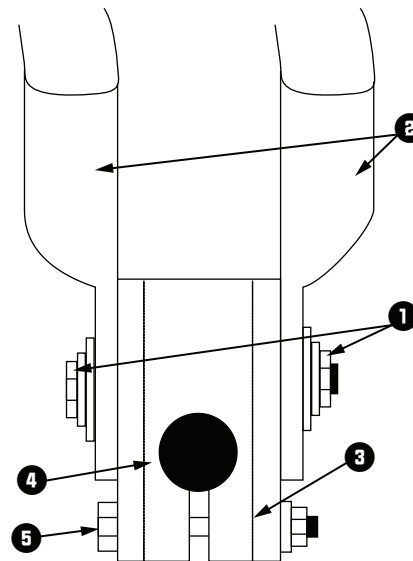

1. Belleville washer
2. Terminal lugs
3. Terminal clamp
4. Motor terminal stud
5. 3/8-in. bolt

Bus Bars

NOTICE

Component Damage!

Failure to follow instructions below could cause an electrical short which could result in component damage.

Remove debris from inside the CPTR option enclosure panel before turning the power on.

Bus bars and extra nuts are available as a Trane option.

Install the bus bars between the motor terminals when using a starter that is:

- A low-voltage Adaptive Frequency™ Drive (AFD)
- Across-the-line
- Primary reactor/resistor
- Autotransformer
- Customer-supplied

Connect T1 to T6, T2 to T4, and T3 to T5.

Note: Bus bars are not needed in medium-voltage or high-voltage applications since only three terminals are used in the motor and starter.

When attaching starter leads to 6.6 to 7kV motor terminals, the 1/2-in.-13 brass jam nuts should be tightened to a maximum torque of 18 to 22 ft·lb (24.4 to 29.8 N·m).



Power Supply Wiring

Always use a second wrench to backup the assembly and prevent applying excessive torque to the terminal shaft.

Starter to Control Panel Wiring

The unit submittal includes the field wiring connection diagram and the starter-to-control-panel connection diagram (showing the electrical connections required between the remote-mounted starter and the control panel).

Note: *Install separate conduit into the low voltage (30 volts) section of the control panel.*

When sizing and installing the electrical conductors for these circuits, follow the guidelines listed. Use 14 AWG for 120V control circuits unless otherwise specified.

NOTICE

Adaptive Frequency Drive (AFD)/Starter Component Damage!

Failure to remove debris from inside the AFD/starter panel could result in an electrical short and could cause serious AFD/starter component damage.

Important: *Maintain at least 6 in. (16 cm) between low-voltage (less than 30V) and high-voltage circuits. Failure to do so could result in electrical noise that may distort the signals carried by the low-voltage wiring, including the inter-processor communication (IPC) wiring.*

To wire the starter to the control panel, use these guidelines:

- If the starter enclosure must be cut to provide electrical access, exercise care to prevent debris from falling inside the enclosure. Do NOT cut the Adaptive Frequency™ Drive (AFD) enclosure.
- Use only shielded, twisted-pair wiring for the inter-processor communication (IPC) circuit between the starter and the control panel on remote-mounted starters.

Note: *Recommended wire is Beldon Type 8760, 18 AWG for runs up to 1000 ft (304.8 m). The polarity of the IPC wiring is critical for proper operation.*

- Separate low-voltage (less than 30V; refer to the tables in “Trane-supplied Starter Wiring,” p. 57 and “Customer-supplied Remote Starter Wiring,” p. 58) wiring from the 115V wiring by running each in its own conduit.
- When routing the IPC circuit out of the starter enclosure, ensure that it is at least 6 in. (16 cm) from all wires carrying a higher voltage.

⚠ WARNING

Proper Field Wiring and Grounding Required!

Failure to follow code could result in death or serious injury.

All field wiring MUST be performed by qualified personnel. Improperly installed and grounded field wiring poses FIRE and ELECTROCUTION hazards. To avoid these hazards, you MUST follow requirements for field wiring installation and grounding as described in NEC and your local/state/national electrical codes.

Important:

- *The IPC wiring shield should be grounded on one end only at control panel end. The other end should be un-terminated and taped back on the cable sheath to prevent any contact between shield and ground.*
- *Oil Pump Interlock: All starters must provide an interlock (normally open) contact with the chiller oil pump connected to the control panel at terminals 1A7-2-4 and 1A7-J2-2 (14 AWG). The purpose of this interlock is to maintain the oil pump signal in the event that a starter failure, such as welded contacts, keeps the chiller motor running after the controller interrupts the run signal.*

10 to 13.8kV Medium Voltage Motor

⚠ WARNING

Hazardous Voltage!

Failure to disconnect power before servicing could result in death or serious injury.

Disconnect all electric power, including remote disconnects before servicing. Follow proper lockout/tagout procedures to ensure the power can not be inadvertently energized. Verify that no power is present with a voltmeter.

All electrical circuits shall be treated as energized until all lockout/tagout procedures are in place and the circuit has been tested to verify that it is de-energized. The medium-voltage motor terminal box cover must NOT be removed if power is present, or if there is a possibility that power may be present. Working on energized medium-voltage circuits is not an approved practice for normal HVAC maintenance or service.

The motor is suitable for remote-mounted across-the-line (including circuit breaker starting), primary reactor, autotransformer, or solid-state starting. Refer to the unit nameplate for motor data including RLA, LRA, etc.

In all cases of non-Trane supplied starters, a disconnecting means and short-circuit protection must be installed ahead of the starter, unless they are included as part of the starter.

Note: Trane assumes no responsibility for the design, documentation, construction, compatibility, installation, start-up, or long term support of starters provided by others.

Motor Terminal Box

A large steel motor terminal box is provided to allow for the field connection of the motor power supply wire to the motor.

Figure 43. Motor terminal box dimensions, in. (mm)

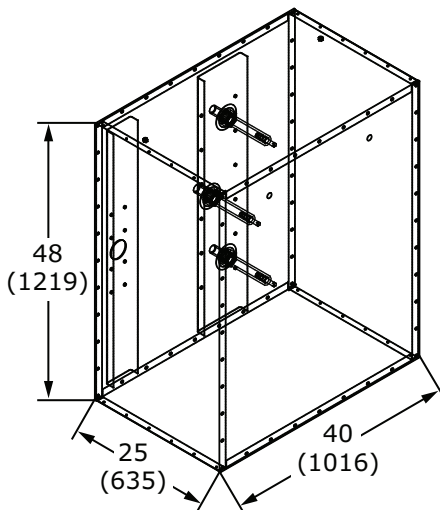

- Motor terminal box cover-only weight is 55 lb (25 kg).
- Two 7/8-in. (22.225 mm) lifting holes are provided in the cover.
- Motor terminal box weight without the cover is 215 lb (97.5 kg).
- Two 3/8-in.-16 weld nuts are provided on the top of the terminal box to allow the use of properly rated lifting D-rings if removal is needed for clearance purposes.

Note: If the box is removed for installation purposes, the motor terminals MUST be protected against impact or stress damage. Field fabrication of a cover or guard is required.

- The motor terminal box is large enough to accommodate the use of stress cones.
- If conduit is applied, a flexible connection of the conduit to the box should be made to allow for unit serviceability and for vibration isolation. The cable should be supported or protected against abrasion and wear on any edges or surfaces. Cable or conduit openings can be cut at any location in the box sides, top, or bottom for cable entry. Always ensure that NO debris remains in the box after cutting cable entry holes.

Motor Supply Wiring

⚠ WARNING

Proper Field Wiring and Grounding Required!

Failure to follow code could result in death or serious injury.

All field wiring MUST be performed by qualified personnel. Improperly installed and grounded field wiring poses FIRE and ELECTROCUTION hazards. To avoid these hazards, you MUST follow requirements for field wiring installation and grounding as described in NEC and your local/state/national electrical codes.

Motor circuit wire sizing by the installer must be made in accordance with the National Electric Code (NEC) or any other applicable codes. All wiring to the CenTraVac® chiller motor must be shielded copper, with insulation rated to a minimum of 15kV.

Three terminals are provided on the chiller for the connection of power to the motor from the starter. Power leads to motors must be in multiples of three, with equal phase representation in all conduits or wire trays. To limit the effects of corona or ionization with cables carrying more than 2000V, Trane requires that the power cable have a metallic shield, unless the cable is specifically listed or approved for non-shielded use. If the cable is shielded, the shielding must be grounded at one end (grounding is typically done at the starter or supply end).



10 to 13.8kV Medium Voltage Motor

Care must be taken while routing the incoming cables to ensure that cable loads or tensions are not applied to the terminal or premature terminal failure could result.

Motor Terminals

Field-provided, ring-type lugs, with no sharp edges or corners, must be used by a qualified installer to connect the power wiring to the motor terminals. Follow all instructions provided with the field-provided lugs to ensure proper connections.

Important: *The use of stress cones is highly recommended to reduce and control longitudinal and radial electrical stresses at the cable ends.*

Prior to assembly the terminal stud, nuts, and lug should be inspected and cleaned to ensure they are not damaged or contaminated.

The terminal has a copper shaft that is threaded 9/16-in.-18 UNF2A. Brass nuts are provided on the motor terminals to retain the lugs, and the final connection should be tightened to 22 to 25 ft·lb (29.8 to 33.9 N·m) using a 7/8-in. (22.225-mm) socket on a torque wrench.

NOTICE

Motor Terminal Damage!

Applying torque to the motor terminal when tightening lugs could result in equipment or property-only damage.

Always use a second wrench to back-up the assembly and prevent the application of torque to the terminal shaft.

Before beginning wiring and torquing, ensure proper motor terminal care and do NOT apply any excess stress.

Ground Wire Terminal Lug

A ground wire lug is provided in the motor terminal box to allow the field connection of an earth ground. The lug will accept a field-supplied ground wire of #8 to #2 AWG. After completing the field connection of wiring, inspect and clean the motor terminals and motor housing, and remove any debris before reinstalling the motor terminal box cover. The cover must be re-installed onto the motor terminal box and all bolts installed. Do NOT operate the chiller with the motor terminal box cover removed or with any loose or missing cover bolts.



System Control Circuit Wiring (Field Wiring)

Table 22. Unit control panel wiring 120 Vac

Standard Control Circuits: Unit Control Panel Control Wiring (120 Vac)	Unit Control Terminations	Input or Output Type	Contacts
Chilled Water Flow Proving Input ^(a)	1X1-5 to 1A6-J3-2	Binary Input	Normally Open, Closure with Flow
Condenser Water Flow Proving Input ^(b)	1X1-6 to 1A6-J2-2	Binary Input	Normally Open, Closure with Flow
Chilled Water Pump Relay Output	1A5-J2-4 to 6	Binary Output	Normally Open
Condenser Water Pump Relay Output	1A5-J2-1 to 3	Binary Output	Normally Open
Optional Control Circuits (120 Vac)	Note: Defaults are factory programmed; alternates can be selected at start-up using the service tool.		
Alarm Relay MAR (Non-Latching) Output	1A8-J2-1 to 3	Binary Output	Normally Open
Limit Warning Relay Output	1A8-J2-4 to 6	Binary Output	Normally Open
Alarm Relay MMR (Latching) Output	1A8-J2-7 to 9	Binary Output	Normally Open
Compressor Running Relay Output	1A8-J2-10 to 12	Binary Output	Normally Open
Maximum Capacity Relay Output	1A9-J2-1 to 3	Binary Output	Normally Open
Head Relief Request Relay Output	1A9-J2-4 to 6	Binary Output	Normally Open
Purge Alarm Relay Output	1A9-J2-7 to 9	Binary Output	Normally Open
Ice Building Relay Output	1A5-J2-10 to 12	Binary Output	Normally Open
Free Cooling Relay Output	1A11-J2-4 to 6	Binary Output	Normally Open
Standard Low Voltage Circuits (Less than 30 Vac)^(c)	Unit Control Panel Terminations	Input or Output Type	Contacts
External Auto Stop Input	1A13-J2-1 to 2	Binary Input	Closure Required for Normal Operation
Emergency Stop Input	1A13-J2-3 to 4	Binary Input	Closure Required for Normal Operation
Optional Low Voltage Circuits			
External Base Loading Enable Input	1A18-J2-1 to 2	Binary Input	Normally Open
External Hot Water Control Enable Input	1A18-J2-3 to 4	Binary Input	Normally Open
External Ice Building Control Enable Input	1A19-J2-1 to 2	Binary Input	Normally Open
External Free Cooling Input Enable Input	1A20-J2-1 to 2	Binary Input	Normally Open
% RLA Compressor Output	1A15-J2-1 to 3	Analog Output	2–10 Vdc
External Condenser Pressure Output	1A15-J2-4 to 6	Analog Output	2–10 Vdc
Evaporator/Condenser Differential Pressure Output	1A15-J2-4 to 6	Analog Output	2–10 Vdc
Condenser Head Pressure Control	1A15-J2-4 to 6	Analog Output	0–10 Vdc
External Demand Limit Setpoint Input	1A16-J2-2 to 3	Analog Input	2–10 Vdc, or 4–20 mA
External Chilled Water Setpoint Input	1A16-J2-5 to 6	Analog Input	2–10 Vdc, or 4–20 mA
External Base Loading Setpoint Input	1A17-J2-2 to 3	Analog Input	2–10 Vdc, or 4–20 mA
Generic Refrigerant Monitor Input	1A17-J2-5 to 6	Analog Input	2–10 Vdc, or 4–20 mA
Outdoor Air Temperature Sensor	Inter-processor Communication (IPC) Bus Connection and Sensor	Communication and Sensor	—
LonTalk® Module	1K47	LonTalk	Comm Link
BACnet® or Modbus™	1A22-ETHERNET 1 OR 1A22-P1(+) to 1A22-P1(-)	Communication to BACnet or Modbus	Comm Link

Note: All wiring to be in accordance with National Electrical Code (NEC) and any local codes.

- ^(a) If the Chilled Water Flow Proving Input is a factory-installed ifm efector flow-sensing device, the secondary field device (recommended with 38°F [3.3°C] and lower leaving chilled water temperatures) for proof of flow connects from 1X1-5 to 1K26-4 (binary input; normally open, closure with flow). Remove factory jumper when used.
- ^(b) If the Condenser Water Flow Proving Input is a factory-installed ifm efector flow-sensing device, the secondary (optional) field device for proof of flow connects from 1X1-6 to 1K27-4 (binary input; normally open, closure with flow). Remove factory jumper when used. If the Second Condenser Water Flow Proving Input is a factory-installed ifm efector flow-sensing device, the secondary (optional) field device for proof of flow connects from 1X1-8 to 1K28-4 (binary input; normally open, closure with flow). Remove factory jumper when used.
- ^(c) Standard low-voltage circuits (less than 30 Vac) must be separated from 120 Vac or higher wiring.

Water Pump Interlock Circuits and Flow Switch Input

⚠ WARNING

Hazardous Voltage!

Failure to disconnect power before servicing could result in death or serious injury.

Disconnect all electric power, including remote disconnects before servicing. Follow proper lockout/tagout procedures to ensure the power can not be inadvertently energized. Verify that no power is present with a voltmeter.

Note: The circuits for the chilled water proof of flow and the condenser water proof of flow do NOT require external power. Refer to the wiring diagrams that shipped with the chiller.

Chilled Water Pump

1. Wire the evaporator water pump contactor (5K1) to a separate 120 volt single-phase power supply with 14 AWG, 600V copper wire.
2. Connect circuit to 1A5-J2-6.
3. Use 1A5-J2-4 120 Vac output to allow the control panel to control the evaporator water pump, or wire the 5K1 contactor to operate remotely and independently of the control panel.

Chilled Water Proof of Flow

When this circuit is installed properly and the evaporator pump is running and providing the required minimum flow, this circuit will prove the evaporator water flow for the chiller controls. Proof of evaporator water flow is required before the start sequence will be allowed to proceed and a loss of evaporator water flow during chiller operation will result in a chiller shutdown.

Refer to as-built schematics on the inside of the control panel for field wiring. This is a dry binary input; normally-open, closure for flow. Apply no external power.

1. With factory-installed ifm efector® flow-sensing devices, a field-provided secondary flow-sensing device is recommended with applications having 38°F (3.3°C) and below leaving evaporator water temperatures. When a secondary flow-sensing device is used, remove the factory jumper and install its contacts between 1X1-5 to 1K26-4; this places the secondary flow sensing device in series with the ifm efector® flow-sensing device.
2. For field-provided primary proof of flow devices, connect the primary proof of flow device between terminals 1X1-5 to 1A6-J3-2. A secondary field device is recommended with applications having 38°F (3.3°C) and below leaving evaporator water temperatures, and must be field-wired in series with the primary proof of flow device.

Condenser Water Pump

1. Wire the condenser water pump contactor (5K2) to a separate 120-volt, single-phase power supply with 14 AWG, 600-volt copper wire.
2. Connect circuit to control panel terminals 1A5-J2-3.
3. Use 1A5-J2-1 120 Vac output to allow the control panel to control the condenser pump.

Condenser Water Proof of Flow

When this circuit is installed properly and the condenser pump is running and providing the required minimum condenser water flow, this circuit will prove the condenser water flow for the chiller controls. Proof of condenser water flow is also required for the start sequence will be allowed to proceed and a loss of condenser water flow during chiller operation will result in a chiller shutdown.

Refer to as-built schematics on the inside of the control panel for field wiring. This is a dry binary input; normally-open, closure for flow. Apply no external power.

1. With factory-installed ifm efector® flow-sensing devices, a secondary field-provided flow-sensing device is optional. When a secondary flow-sensing device is used, remove the factory jumper, and install its contacts between 1X1-6 to 1K27-4; this places the secondary flow sensing device in series with the ifm efector® flow-sensing device.
2. For field-provided primary proof of flow devices, connect the primary proof of flow device between terminals 1X1-6 to 1A6-J2-2. The secondary field provided flow sensing device is optional; however, when it is present, it must be field-wired in series with the primary proof of flow device.

Heat Recovery Proof of Flow

When this circuit is installed properly and the condenser pump is running and providing the required minimum condenser water flow, this circuit will prove the condenser water flow for the chiller controls. Proof of condenser water flow is also required for the start sequence will be allowed to proceed and a loss of condenser water flow during chiller operation will result in a chiller shut-down.

Refer to as-built schematics on the inside of the control panel for field wiring. This is a dry binary input; normally-open, closure for flow. Apply no external power.

1. With factory-installed ifm efector® flow-sensing devices, a secondary field-provided flow-sensing device is optional. When a secondary flow-sensing device is used, remove the factory jumper, and install its contacts between 1X1-8 to 1K28-4; this places the secondary flow sensing device in series with the ifm efector® flow-sensing device.
2. For field-provided primary proof of flow devices, connect the primary proof of flow device between terminals 1X1-6 to 1A29-J3-2. The secondary field provided flow sensing device is optional; however, when it is present, it must be field-wired in series with

the primary proof of flow device.

Temperature Sensor Circuits

All temperature sensors are factory-installed except the optional outdoor air temperature sensor. This sensor is required for the outdoor air temperature type of chilled water reset. Use the following guidelines to locate and mount the outdoor air temperature sensor. Mount the sensor probe where needed; however, mount the sensor module in the control panel.

CWR – Outdoor Option

The outdoor temperature sensor is similar to the unit-mounted temperature sensors in that it consists of the sensor probe and the module. A four-wire inter-processor communication (IPC) bus is connected to the module for 24 Vdc power and the communications link. Trane recommends mounting the sensor module within the control panel and the sensor two wire leads be extended and routed to the outdoor temperature sensor probe sensing location. This ensures the four-wire inter-processor control (IPC) bus protection and provides access to the module for configuration at start-up.

The sensor probe lead wire between the sensor probe and the module can be separated by cutting the two-wire probe lead leaving equal lengths of wire on each device: the sensor probe and the sensor module.

Note: *This sensor and module are matched and must remain together or inaccuracy may occur.*

These wires can then be spliced with two 14 to 18 AWG 600V wires of sufficient length to reach the desired outdoor location with a maximum length 1000 ft (304.8 m). The module four-wire bus must be connected to the control panel four-wire bus using the Trane-approved connectors provided.

The sensor will be configured (given its identity and become functional) at start-up when the Trane service technician performs the start-up configuration. It will NOT be operational until that time.

Note: *If shielded cable is used to extend the sensor leads, be sure to cover the shield wire with tape at the junction box and ground it at the control panel. If the added length is run in conduit, do NOT run them in the same conduit with other circuits carrying 30 or more volts.*

Important: *Maintain at least 6 in. (15.24 cm) between low-voltage (less than 30V) and high voltage circuits. Failure to do so could result in electrical noise that may distort the signals carried by the low-voltage wiring, including the IPC.*

Optional Control and Output Circuits

Install various optional wiring as required by the owner's specifications (see "System Control Circuit Wiring (Field Wiring)," p. 67).

Starter Module Configuration

The starter module configuration settings will be checked (and configured for remote starters) during start-up commissioning.

Note: *To configure starter modules and perform other starter checks, it is recommended that the line voltage three-phase power be turned off and secured (locked out), and then that a separate source control power (115 Vac) be utilized to power up the control circuits.*

Use the as-built starter schematic to ensure correct fuse and terminals. Verify that the correct fuse is removed and that the control circuit connections are correct; then apply the 115 Vac separate source power to service the controls.

Schematic Wiring Drawings

Refer to the submittals and drawings that shipped with the unit. Additional wiring drawings for CenTraVac® chillers are available from your local Trane office.

Operating Principles

General Requirements

Operation and maintenance information are covered in this section. This includes both 50 and 60 Hz centrifugal chillers equipped with the Tracer® Symbio™ 800 control system. This information pertains to all chiller types unless differences exist, in which case the sections are listed by chiller type as applicable and described separately. By carefully reviewing this information and following the instructions given, the owner or operator can successfully operate and maintain the chiller. If mechanical problems do occur, however, contact a Trane service technician to ensure proper diagnosis and repair of the unit.

Important: Although CenTraVac® chillers can operate through surge, it is NOT recommended to operate them through repeated surges over long durations. If repeated surges of long durations occur, contact your Trane Service Agency to resolve the issue.

Cooling Cycle

When in the cooling mode, liquid refrigerant is distributed along the length of the evaporator and sprayed through small holes in a distributor (i.e., running the entire length of the shell) to uniformly coat each evaporator tube. Here, the liquid refrigerant absorbs enough heat from the system water circulating through the evaporator tubes to vaporize. The gaseous refrigerant is then drawn through the eliminators (which remove droplets of liquid refrigerant from the gas) and the first-stage variable inlet guide vanes, and into the first-stage impeller.

CVHE and CVHG 3-Stage Compressor

Compressed gas from the first-stage impeller flows through the fixed, second-stage inlet vanes and into the second-stage impeller. Here, the refrigerant gas is again compressed, and then discharged through the third-stage variable guide vanes and into the third-stage impeller. After the gas is compressed a third time, it is discharged into the condenser. Baffles within the condenser shell distribute the compressed refrigerant gas evenly across the condenser tube bundle. Cooling tower water circulated through the condenser tubes absorbs heat from the refrigerant, causing it to condense. The liquid refrigerant then passes through an orifice plate and into the economizer.

The economizer reduces the energy requirements of the refrigerant cycle by eliminating the need to pass all gaseous refrigerant through three stages of compression (refer to the following figure). Notice that some of the liquid refrigerant flashes to a gas because of the pressure drop created by the orifice plates, thus further cooling the liquid refrigerant. This flash gas is then drawn directly from the first and second stages of the economizer into the third- and second-stage impellers of the compressor, respectively. All remaining liquid refrigerant flows through another orifice plate to the evaporator.

Figure 44. Pressure enthalpy curve, 3-stage

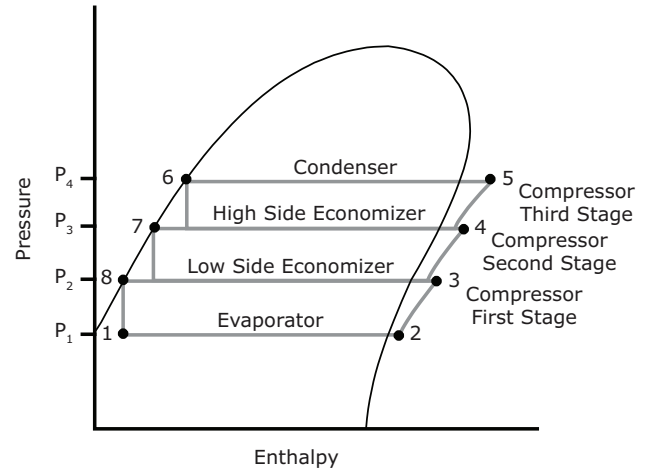
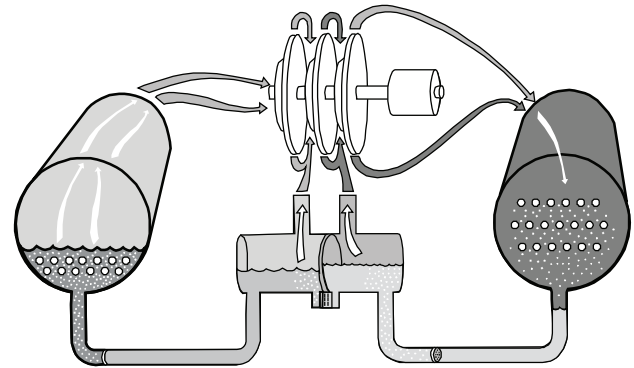

Figure 45. Refrigerant flow, 3-stage



CVHF 2-Stage Compressor

Compressed gas from the first-stage impeller is discharged through the second-stage variable guide vanes and into the second-stage impeller. Here, the refrigerant gas is again compressed, and then discharged into the condenser. Baffles within the condenser shell distribute the compressed refrigerant gas evenly across the condenser tube bundle. Cooling tower water circulated through the condenser tubes absorbs heat from the refrigerant, causing it to condense. The liquid refrigerant then flows out of the bottom of the condenser, passing through an orifice plate and into the economizer.

The economizer reduces the energy requirements of the refrigerant cycle by eliminating the need to pass all gaseous refrigerant through both stages of compression (refer to the following figure). Notice that some of the liquid refrigerant flashes to a gas because of the pressure drop created by the orifice plate, thus further cooling the liquid refrigerant. This flash gas is then drawn directly from the economizer into the second-stage impellers of the compressor. All remaining liquid refrigerant flows out of the

economizer, passing through another orifice plate and into the evaporator.

Figure 46. Pressure enthalpy curve

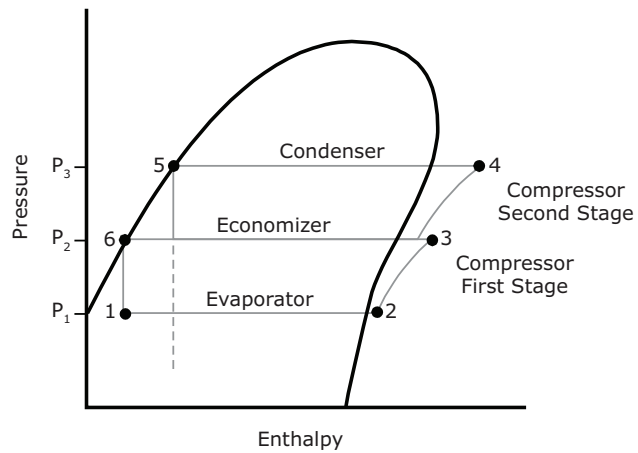
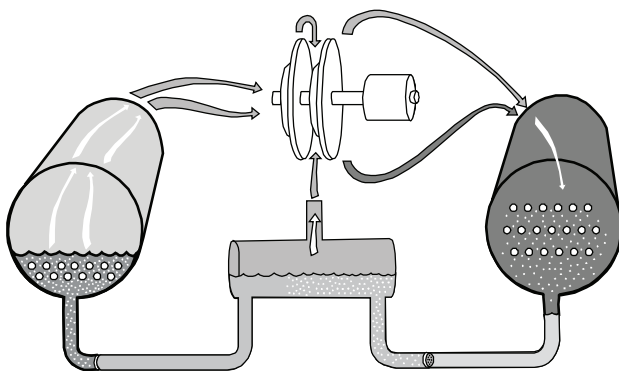

Figure 47. Refrigerant flow, 2-stage



Oil and Refrigerant Pump

Compressor Lubrication System

A schematic diagram of the compressor lubrication system is illustrated in the following figure. Oil is pumped from the oil tank (by a pump and motor located within the tank) through an oil pressure regulating valve designed to maintain a net oil pressure of 18 to 22 psid (124.1 to 151.7 kPaD). It is then filtered and sent to the oil cooler located in the economizer and on to the compressor motor bearings. From the bearings, the oil drains back to the manifold and separator under the motor and then on to the oil tank.

Operating Principles

Figure 48. Oil refrigerant pump, evaporator sizes EXCEPT 032 short/long

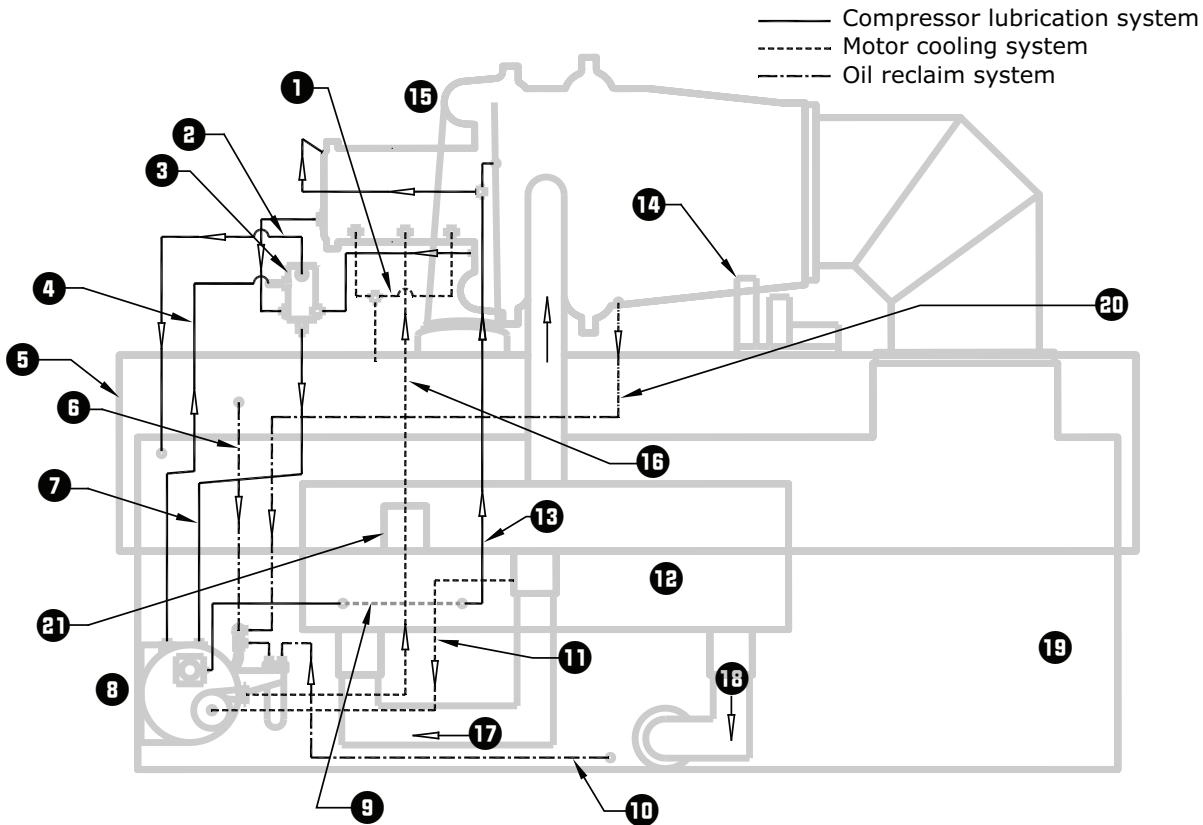

1. Motor coolant return to condenser, 2.125 in. (53.975 mm) OD
2. Oil tank vent to evaporator
3. Oil separator and tank vent manifold
4. Tank vent line
5. Condenser
6. High pressure condenser gas to drive oil reclaim eductors, 0.375 in. (9.525 mm) OD
7. Oil return to tank
8. Oil tank
9. Oil cooler within economizer 0.625 in. (15.875 mm) OD coiled tubing
10. Oil reclaim from evaporator (second eductor), 0.25 in. (6.35 mm) OD
11. Liquid refrigerant to pump, 1.625 in. (41.275 mm) OD
12. Economizer
13. Oil supply to bearings, 0.625 in. (15.875 mm) OD
14. Purge
15. Compressor
16. Liquid refrigerant motor coolant supply, 1.125 in. (28.575 mm) OD
17. Liquid refrigerant to economizer
18. Liquid refrigerant to evaporator
19. Evaporator
20. Oil reclaim from suction cover (first eductor), 0.25 in. (6.35 mm) OD
21. Motor coolant filter

Figure 49. Oil refrigerant pump, 032 short/log evaporator sizes only

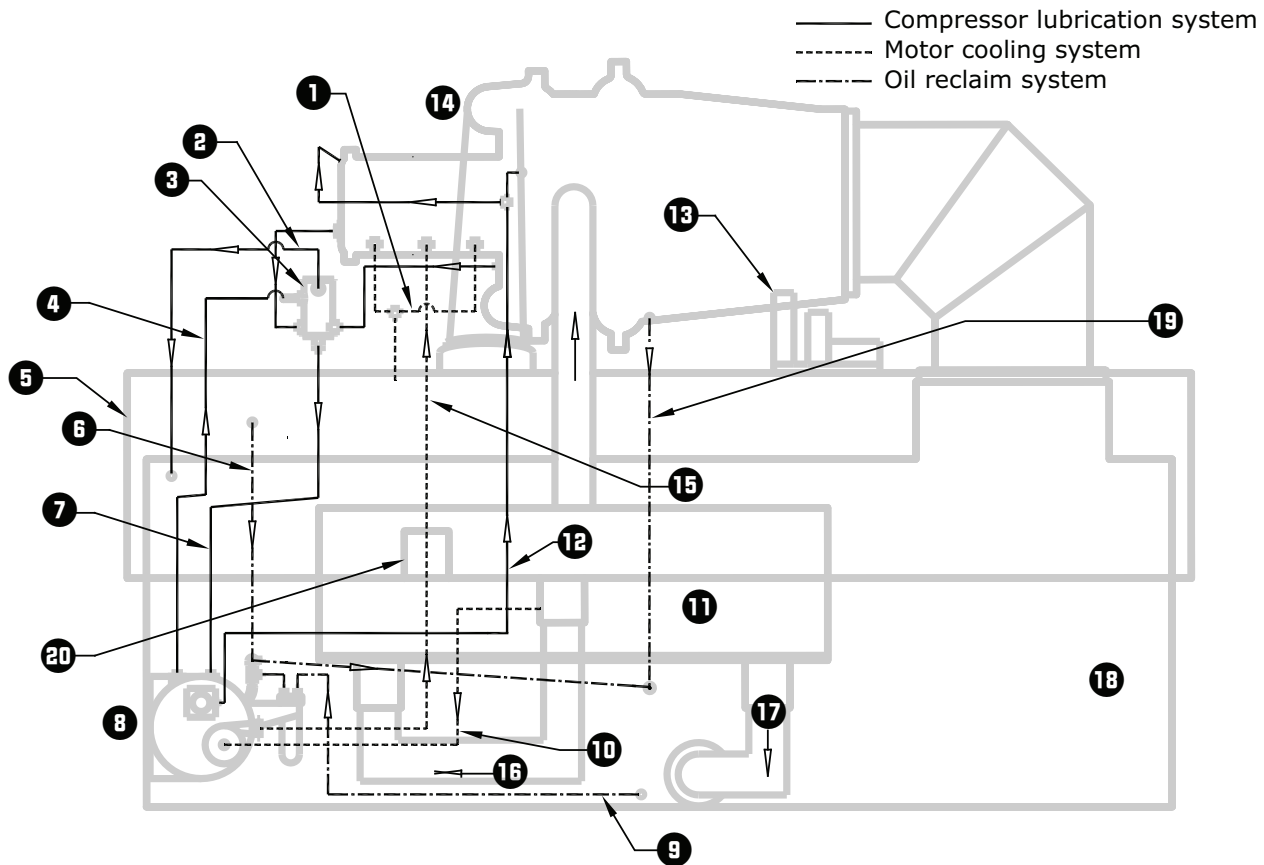

1. Motor coolant return to condenser, 2.125 in. (53.975 mm) OD
2. Oil tank vent to evaporator
3. Oil separator and tank vent manifold
4. Tank vent line
5. Condenser
6. High pressure condenser gas to drive oil reclaim eductors, 0.375 in. (9.525 mm) OD
7. Oil return to tank
8. Oil tank
9. Oil reclaim from evaporator (second eductor), 0.25 in. (6.35 mm) OD
10. Liquid refrigerant to pump, 1.625 in. (41.275 mm) OD
11. Economizer
12. Oil supply to bearings, 0.625 in. (15.875 mm) OD
13. Purge
14. Compressor
15. Liquid refrigerant motor coolant supply, 1.125 in. (28.575 mm) OD
16. Liquid refrigerant to economizer
17. Liquid refrigerant to evaporator
18. Evaporator
19. Oil reclaim from suction cover (first eductor), 0.25 in. (6.35 mm) OD
20. Motor coolant filter

⚠ CAUTION**Hot Surface!**

Failure to follow instructions below could result in moderate injury.

Surface temperatures can reach 150°F (66°C). To avoid possible skin burns, stay clear of these surfaces. If possible, allow surfaces to cool before servicing. If servicing is necessary while surface temperatures are still elevated, you **MUST** put on all Personal Protective Equipment (PPE).

To ensure proper lubrication and prevent refrigerant from condensing in the oil tank, a 750-watt heater is in a well in the oil tank. The heater is used to warm the oil while the unit is off. With the default settings for R-123, the oil heater is de-energized when the unit starts. With the default settings for R-514A, Running Oil Temperature Control is enabled, and the Running Oil Temperature Setpoint is factory-programmed at 100°F (37.8°C). With either refrigerant, the heater energizes as needed to maintain 140°F to 145°F (60.0°C to 62.8°C) when the chiller is not running.

With R-123 and mineral oil, when the chiller is operating, the temperature of the oil tank is typically 100°F to 160°F (37.8°C to 71.1°C). With R-514A, solid state oil heater control is installed and enabled. The oil return lines from the thrust and journal bearings transport oil and some seal leakage refrigerant. The oil return lines are routed into a manifold and separator under the motor. Gas flow exits the top of the manifold and is vented to the evaporator. Oil exits the bottom of the manifold and returns to the tank. Separation of the seal leakage gas in the separator keeps this gas out of the tank.

A dual eductor system is used to reclaim oil from the suction cover and the evaporator, and deposit it back into the oil tank. These eductors use high-pressure condenser gas to draw the oil from the suction cover and evaporator to the eductors and then discharge into the oil tank. The evaporator eductor line has a shut-off valve mounted by the evaporator. The position of the shut-off valve will be set at three-quarters of a turn open during commissioning, but may be adjusted later by a qualified technician as necessary for oil return. A normal operating setting for the valve may range from full closed to two turns open.

Note: Depending on operating conditions, the oil sump's normal operating oil level may vary from just below the bottom sight glass to near the top of the upper sight glass.

Liquid refrigerant is used to cool the oil supply to both the thrust bearing and journal bearings. On refrigerant pump units, the oil cooler is located inside the economizer and uses refrigerant passing from the condenser to evaporator to cool the oil. Oil leaves the oil cooler and flows to both the thrust and journal bearings.

Motor Cooling System

Compressor motors are cooled with liquid refrigerant (refer to the figures in “Compressor Lubrication System,” p. 71). The refrigerant pump is located on the front of the oil tank (motor inside the oil tank). The refrigerant pump inlet is connected to the well at the bottom of the condenser. The connection is on the side where a weir ensures a preferential supply of liquid refrigerant. Refrigerant is delivered to the motor via the pump. An in-line filter is installed (replace the in-line filter only with major service). Motor refrigerant drain lines are routed to the condenser.

Tracer[®] AdaptiView™ Display

Information is tailored to operators, service technicians, and owners.

When operating a chiller, specific information is needed you needed on a day-to-day basis—setpoints, limits, diagnostic information, and reports.

Day-to-day operational information is presented at the display. Logically organized groups of information—chiller modes of operation, active diagnostics, settings, graphs, and reports put information conveniently at your fingertips. For more information, see *AdaptiView™ Display with Symbio™ Controls CenTraVac® Water-Cooled Chillers, User Guide* (CTV-SVU004*-EN).

Start-Up and Shutdown

This section provides basic information on chiller operation for common events.

Sequence of Operation

Adaptive control algorithms are used on CenTraVac® chillers. This section illustrates common control sequences.

Software Operation Overview Diagram

The following figure is a diagram of the five possible software states. This diagram can be thought of as a state chart, with the arrows and arrow text, depicting the transitions between states:

- The text in the circles is the internal software designations for each state.

- The first line of text in the circles is the visible top level operating modes that can be displayed in Tracer® AdaptionView™.
- The shading of each software state circle corresponds to the shading on the time lines that show the chiller's state.

There are five generic states that the software can be in:

- Power Up
- Stopped
- Starting
- Running
- Stopping

Figure 50. Software operation overview

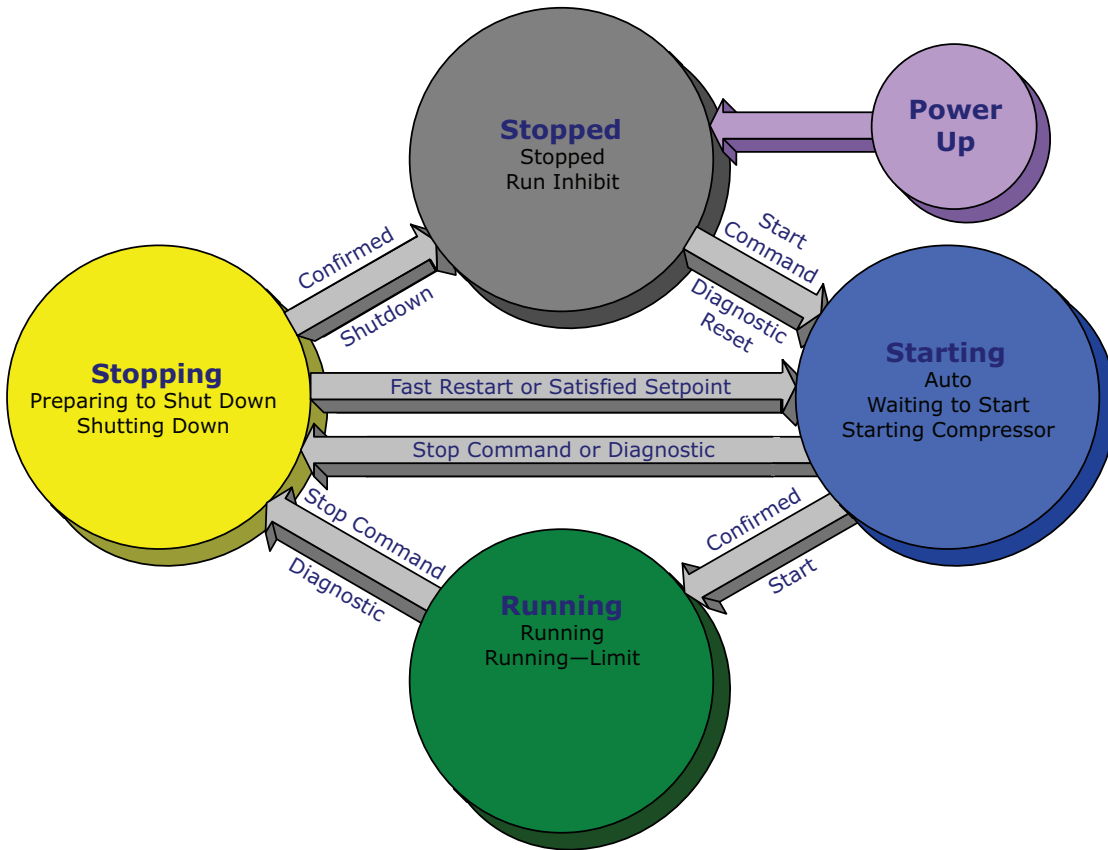
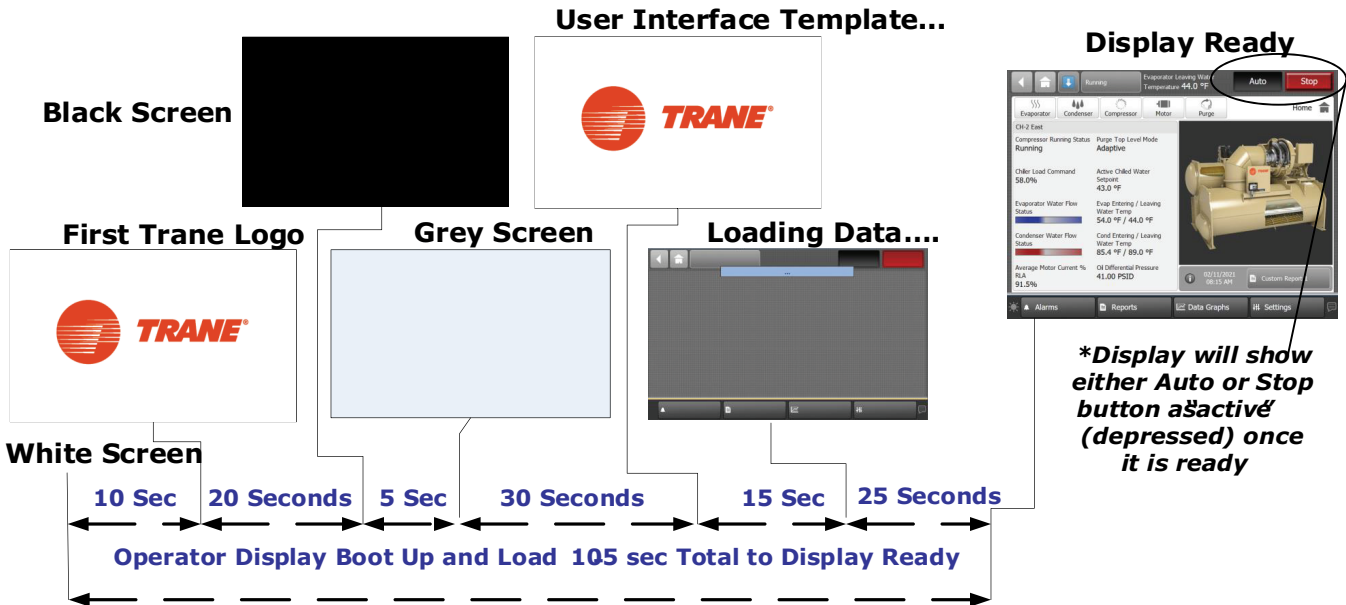

Figure 51. Sequence of operation: Tracer® AdaptiView™ power up



In the following diagrams:

- The time line indicates the upper level operating mode, as it would be viewed in the Tracer AdaptiView.
- The shading color of the cylinder indicates the software state.
- Text in parentheses indicates sub-mode text as viewed in the Tracer AdaptiView.
- Text above the time line cylinder is used to illustrate inputs to the Symbio™ 800. This may include user input to the Tracer AdaptiView touch screen, control inputs from sensors, or control inputs from a generic BAS.
- Boxes indicate control actions such as turning on relays, or moving the inlet guide vanes.
- Smaller cylinders under the main cylinder indicate diagnostic checks.
- Text outside a box or cylinder indicates time-based functions.
- Solid double arrows indicate fixed timers.
- Dashed double arrows indicate variable timers.

Start-Up Sequence of Operation—Wye-delta

Logic circuits within the various modules will determine the starting, running, and stopping operation of the chiller. When operation of the chiller is required, the chiller mode is set at **Auto**. Using customer-supplied power, the chilled water pump relay is energized and chilled water flow must be verified within 4 minutes and 15 seconds. The controller decides to start the chiller based on the differential to start setpoint. With the differential to start criteria met, the controller then energizes condenser water pump relay with customer-supplied power (see the [Figure 52, p. 77](#)).

Based on the Restart Inhibit function and the Differential to Start setpoint, the oil and refrigerant pump is energized. The oil pressure must be at least 12 psid (82.7 kPaD) for 60 continuous seconds and condenser water flow verified within 4 minutes and 15 seconds for the compressor start sequence to be initiated.

The compressor motor starts in the Wye configuration and then, after the compressor motor has accelerated and the maximum phase current has dropped below 85 percent of the chiller nameplate RLA for 1.5 seconds, the starter transitions to the Delta configuration.

Figure 52. Sequence of operation: power up to starting

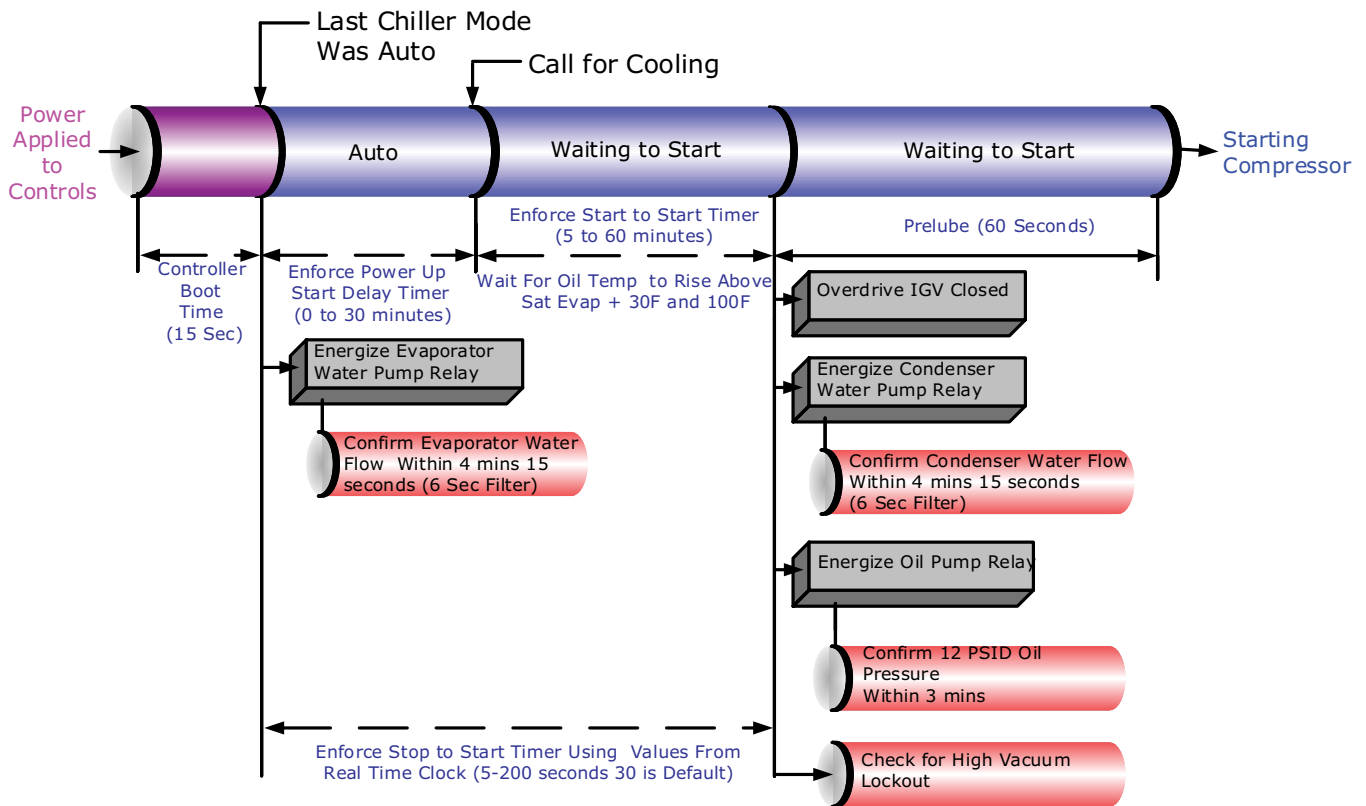

Now that the compressor motor is running in the Delta configuration, the inlet guide vanes will modulate, opening and closing to the chiller load variation by operation of the stepper vane motor actuator to satisfy chilled water setpoint. The chiller continues to run in its appropriate mode of operation: Normal, Softload, Limit Mode, and so on (see the [Figure 53, p. 78](#)).

If the chilled water temperature drops below the chilled water setpoint by an amount set as the differential to stop setpoint, a normal chiller stop sequence is initiated as follows:

1. The inlet guide vanes are driven closed (up to

50 seconds).

2. After the inlet guide vanes are closed, the stop relay and the condenser water pump relays open to turn off. The oil and refrigerant pump motor will continue to run for 3 minutes post-lube while the compressor coasts to a stop. The chilled water pump will continue to run while the controller monitors leaving chilled water temperature, preparing for the next compressor motor start based on the differential to start setpoint.

The following illustrates this sequence.

Figure 53. Sequence of operation: running

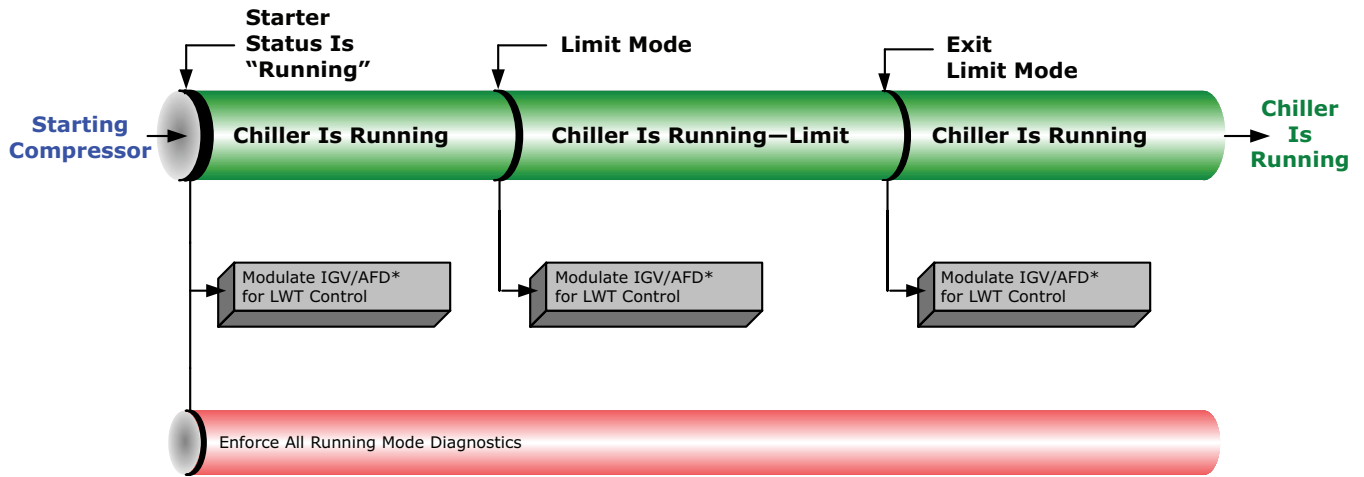

*Note: AFD applies to CVH only.

Figure 54. Sequence of operation: satisfied setpoint

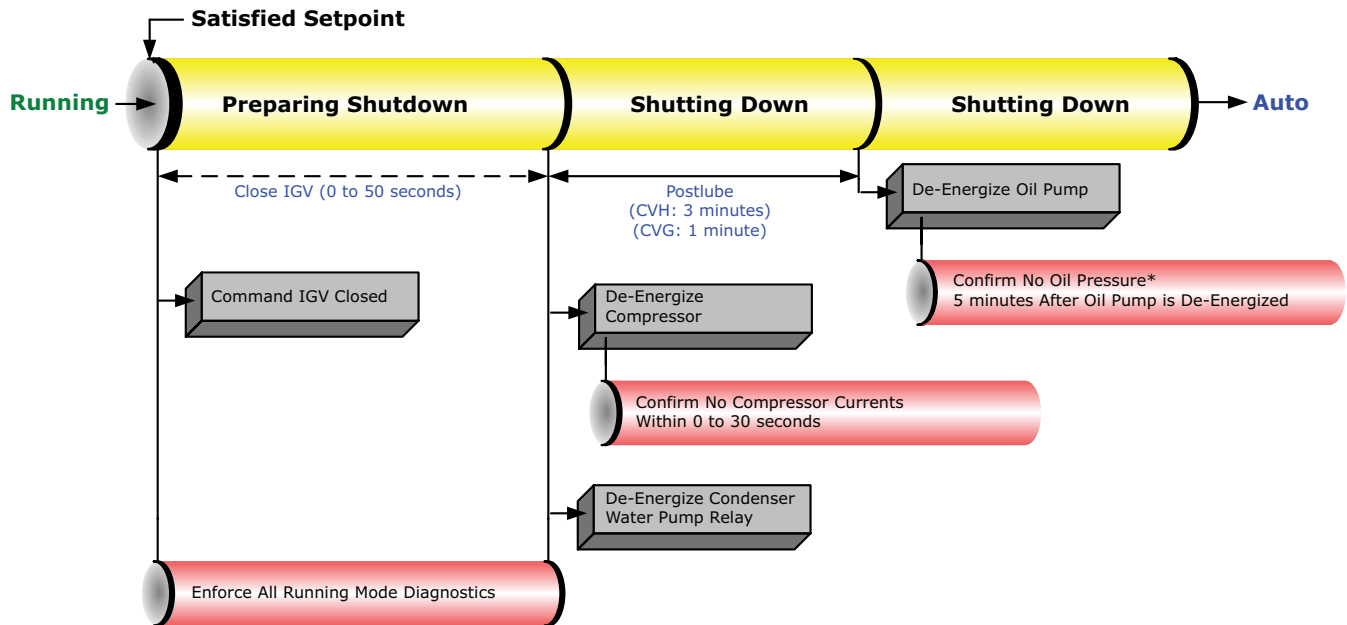

*Note: CVH: No oil pressure is less than 3 psid (20.7 kPaD)
CVG: No oil pressure is opened Oil Differential Pressure Switch

If the **STOP** key is pressed on the operator interface, the chiller will follow the same stop sequence as described earlier except the chilled water pump relay will also open and stop the chilled water pump after the chilled water pump delay timer has timed out after compressor shutdown (see the following).

If the immediate stop is initiated, a panic stop occurs which follows the same stop sequence as pressing the **STOP** key once, except the inlet guide vanes are not sequence-closed and the compressor motor is immediately turned off.

Figure 55. Sequence of operation: Fast restart within postlube

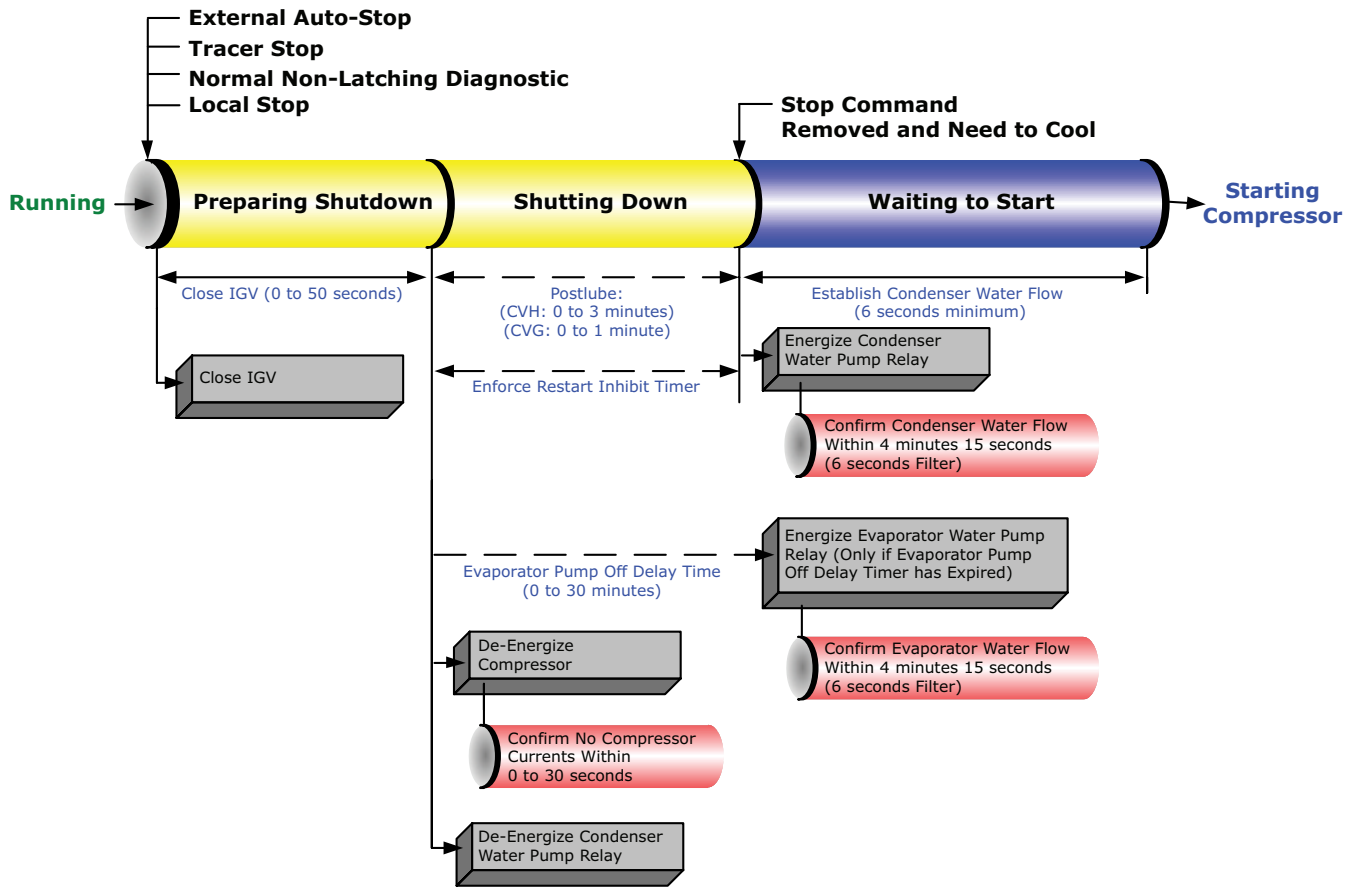
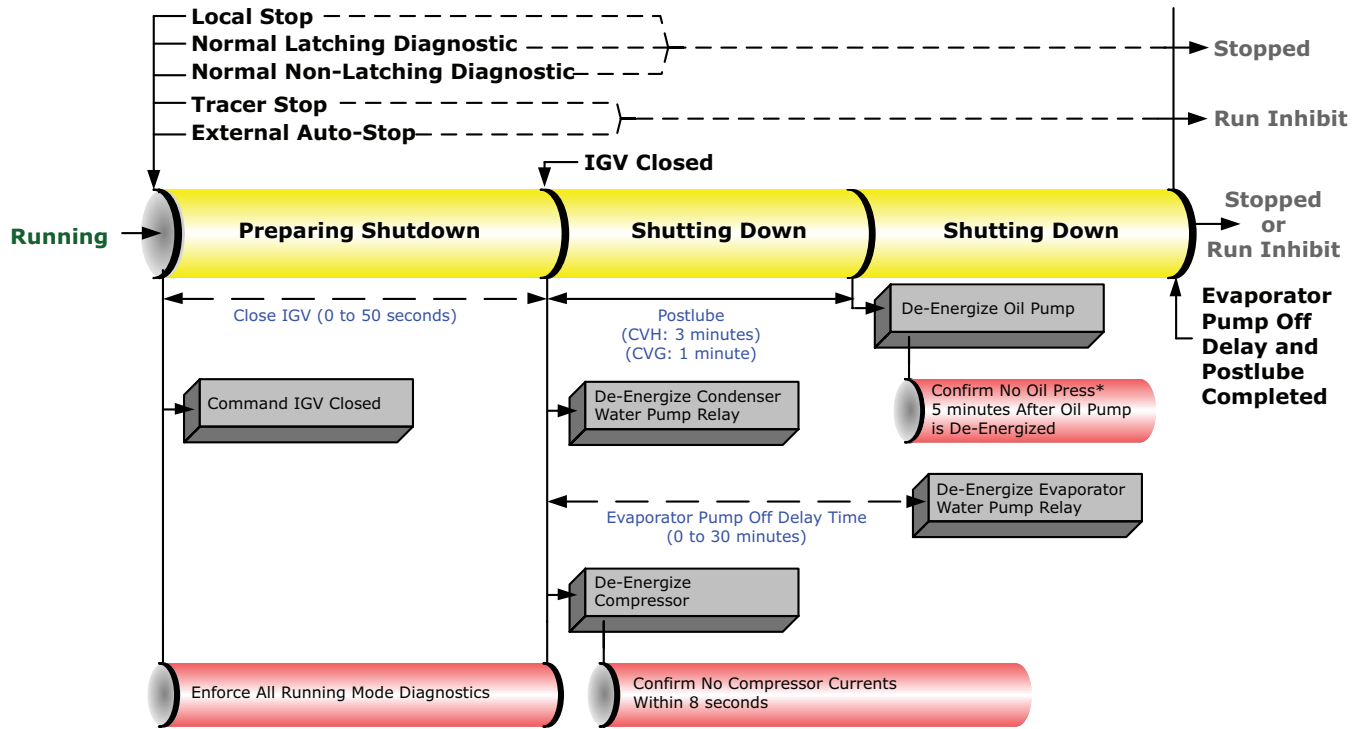

Figure 56. Sequence of operation: normal shut-down to stopped and run inhibit



*Note: CVH: No oil pressure is less than 3 psid (20.7 kPaD)
CVG: No oil pressure is opened Oil Differential Pressure Switch

Power Up

"Software Operation Overview Diagram," p. 75 includes an illustration of Tracer® Symbio 800 during a power up of the controller. This process takes up to 15 seconds, depending on the number of installed options.

Ice Building Control

The control panel provides a service level Enable or Disable menu entry for the Ice Building feature when the Ice Building option is installed. Building can be entered from Front Panel or, if hardware is specified, the control panel will accept either an isolated contact closure 1A19 Terminals J2-1 and J2-2 (Ground) or a remote-communicated input (BAS) to initiate the Ice Building mode where the unit runs fully loaded at all times. Ice Building will be terminated either by opening the contact or based on entering evaporator fluid temperature. The control panel will not permit the Ice Building mode to be entered again

until the unit is switched to the non-ice building mode and back into the ice building mode. It is not acceptable to reset the chilled water setpoint low to achieve a fully loaded compressor. When entering Ice Building, the compressor will be loaded at its maximum rate and when leaving Ice Building, the compressor will be unloaded at its maximum rate. While loading and unloading the compressor, all surge detection will be ignored. While in the ice building mode, demand limit setpoints less than the maximum will be ignored. Ice Building can be terminated by one of the following means:

- Front panel disable
- Opening the external ice contacts/remote-communicated input (BAS)
- Satisfying an evaporator entering fluid temperature setpoint (default is 27°F [-2.8°C])
- Surging for seven minutes at full open inlet guide vanes (IGV)

Figure 57. Sequence of operation: ice building: running to ice making

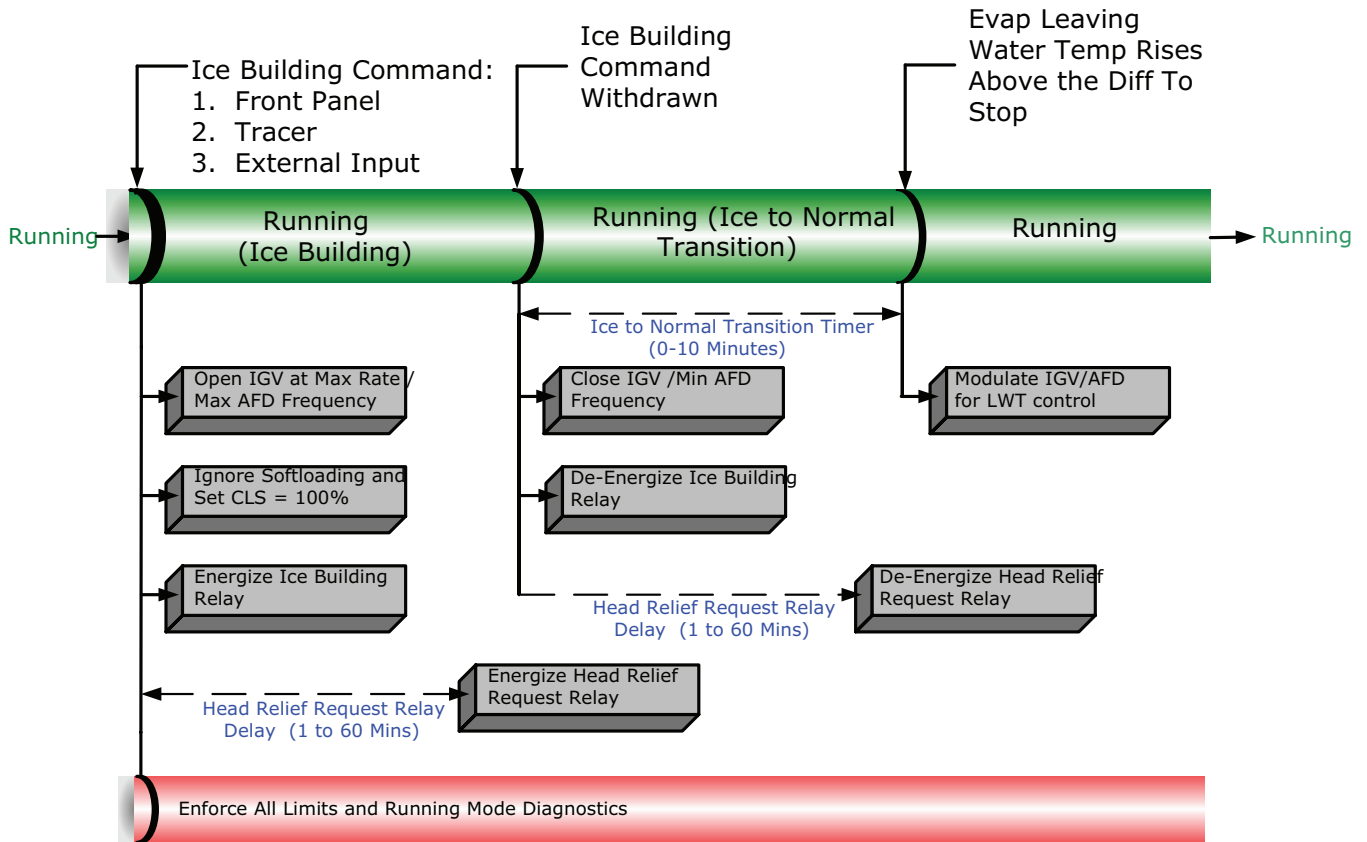
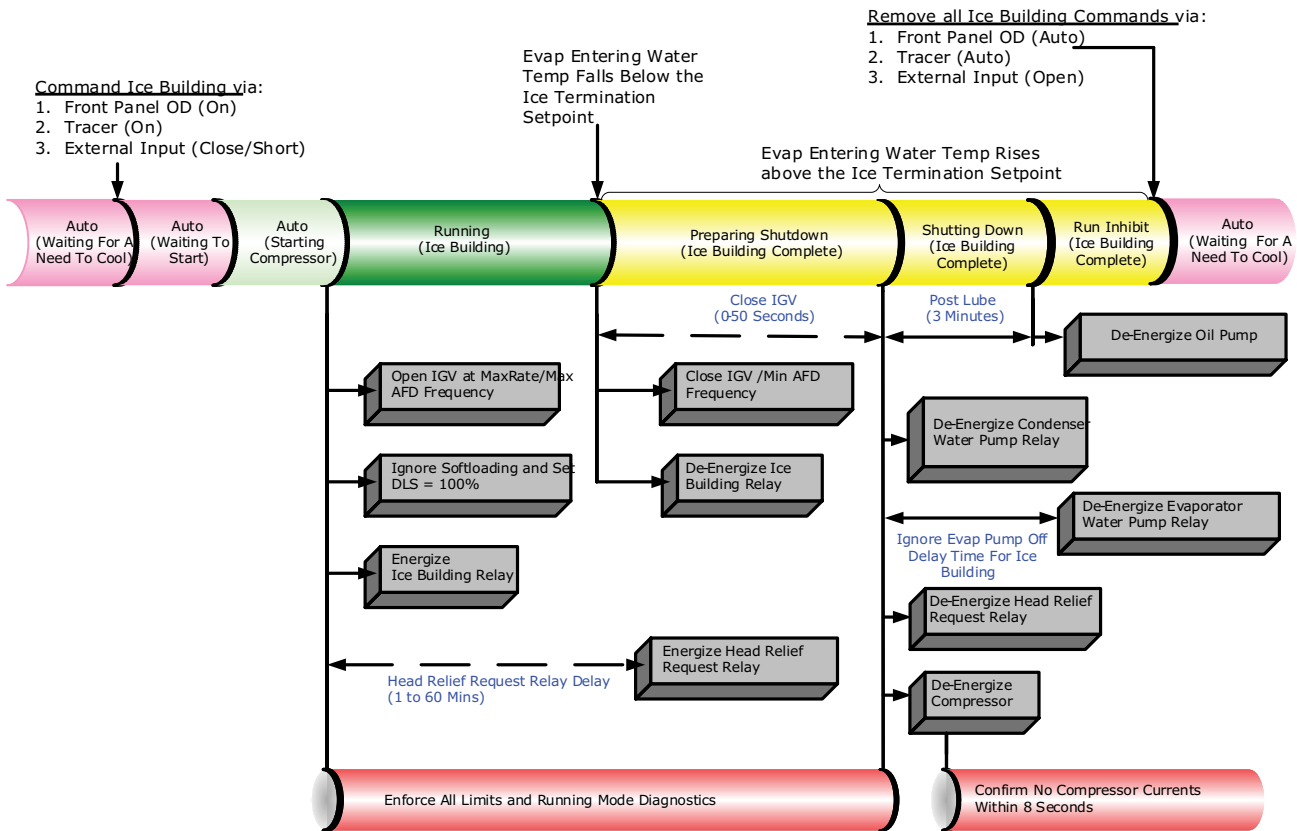

Figure 58. Sequence of operation: ice building: auto to ice to ice building complete to auto



Free Cooling Cycle

Based on the principle that refrigerant migrates to the coldest area in the system, the free cooling option adapts the basic chiller to function as a simple heat exchanger. However, it does not provide control of the leaving chilled water temperature.

If condenser water is available at a temperature lower than the required leaving chilled water temperature, the operator interface must remain in **AUTO** and the operator starts the free cooling cycle by enabling the Free Cooling mode in the Tracer® AdaptiView™ Feature Settings group of the operator interface, or by means of a BAS request. The following components must be factory- or field-installed to equip the unit for free cooling operation:

- a refrigerant gas line, and electrically-actuated shutoff valve, between the evaporator and condenser,
- a valved liquid return line, and electrically-actuated shutoff valve, between the condenser sump and the evaporator,
- a liquid refrigerant storage vessel (larger economizer), and
- additional refrigerant.

When the chiller is changed over to the free cooling mode, the compressor will shutdown if running and the shutoff valves in the liquid and gas lines open; unit control logic prevents the compressor from energizing during free

cooling. Liquid refrigerant then drains (by gravity) from the storage tank into the evaporator and floods the tube bundle. Since the temperature and pressure of the refrigerant in the evaporator are higher than in the condenser (i.e., because of the difference in water temperature), the refrigerant in the evaporator vaporizes and travels to the condenser, cooling tower water causes the refrigerant to condense on the condenser tubes, and flow (again, by gravity) back to the evaporator.

This compulsory refrigerant cycle is sustained as long as a temperature differential exists between condenser and evaporator water. The actual cooling capacity provided by the free cooling cycle is determined by the difference between these temperatures which, in turn, determines the rate of refrigerant flow between the evaporator and condenser shells.

If the system load exceeds the available free cooling capacity, the operator must manually initiate changeover to the mechanical cooling mode by disabling the free cooling mode of operation. The gas and liquid line valves then close and compressor operation begins (refer to the figure in “Start-Up Sequence of Operation—Wye-delta,” p. 76 [power up to starting], beginning at Auto mode). Refrigerant gas is drawn out of the evaporator by the compressor, where it is then compressed and discharged to the condenser. Most of the condensed refrigerant initially follows the path of least resistance by flowing into the storage tank. This tank is vented to the economizer sump

through a small bleed line; when the storage tank is full, liquid refrigerant must flow through the bleed line restriction. Because the pressure drop through the bleed line is greater than that of the orifice flow control device, the liquid refrigerant flows normally from the condenser through the orifice system and into the economizer.

Free Cooling (FRCL)

To enable Free Cooling mode:

1. Install and commission Free Cooling.
2. Enable the **Free Cooling** mode in the Tracer® AdaptiView™ Settings menu.
3. Press **AUTO**, and if used, close the external binary input switch (connected to 1A20 J2-1 to 2) while the chiller is in **AUTO**.

Note: Free Cooling cannot be entered if the chiller is in **STOP**.

If the chiller is in **AUTO** and not running, the condenser water pump will start. After condenser water flow is proven, Relay Module 1A11 will energize operating the Free Cooling Valves 4B12 and 4B13. The Free Cooling Valves End Switches must open within 3 minutes, or an MMR diagnostic will be generated. Once the Free Cooling Valves End Switches open, the unit is in the **Free Cooling** mode. If the chiller is in **AUTO** and running powered cooling, the chiller will initiate a friendly shutdown first (Run: Unload, Post Lube, and drive vanes closed). After the vanes have been overdriven closed and condenser water flow proven, the Free Cooling relays will be energized. To disable Free Cooling and return to Powered Cooling, either disable the Free Cooling Mode in the Tracer AdaptiView Settings menu if used to enable **Free Cooling**, or **OPEN** the external binary input switch to the 1A20 Module if it was used to enable **Free Cooling**. Once **Free Cooling** is disabled, the Free Cooling relays Relay Module 1A11 will de-energize allowing the Free Cooling valves to close. The Free Cooling valves end switches must close within 3 minutes or an MMR diagnostic is generated. After the end switches close, the chiller will return to **AUTO** and powered cooling will resume if there is a call for cooling based on the differential to start.

Notes:

- The manual control of the inlet guide vanes is disabled while in the **Free Cooling** mode and the compressor is prevented from starting by the control logic.
- The relay at 1A11-J2-4 to 6 is a FC auxiliary relay and can be used as required.

Hot Gas Bypass (HGBP)

The hot gas bypass (HGBP) control option is designed to minimize machine cycling by allowing the chiller to operate stably under minimum load conditions. In these situations, the inlet guide vanes are locked at a preset minimum position, and unit capacity is governed by the HGBP valve actuator. Control circuitry is designed to allow both the inlet

guide vanes and the HGBP valve to close for unit shutdown. After a chiller starts and is running, the inlet guide vanes will pass through the HGBP Cut-In-Vane position as the chiller starts to load. As the chiller catches the load and starts to unload, the inlet guide vanes will close to the Hot Gas Bypass Cprsr Ctrl Command position. At this point, the movement of the inlet guide vanes is stopped and further loading/unloading of the chiller is controlled by the opening/closing of the HGBP Valve (4M5). When the control algorithm determines the chiller to be shut down, the inlet guide vanes will be driven fully closed and the HGBP valve will be driven closed. After the inlet guide vanes are fully closed, the chiller will shut down in the Friendly mode. Chillers with HGBP have a discharge temperature sensor (4R16) monitoring the discharge gas temperature from the compressor. If this temperature exceeds the High Cprsr Rfght Discharge Temp Cutout 200°F (93.3°C) default, the chiller will shut off on a MAR diagnostic. The chiller will reset automatically when this temperature drops 50°F (10.0°C) below the trip-point. HGBP is enabled in the Features Menu Settings group of the Tracer® AdaptiView™ menus by enabling the option. The setting of the HGBP Cut-In Vane Position is set-up at unit commissioning via the service tool.

Hot Water Control

Occasionally, CenTraVac™ chillers are selected to provide heating as a primary mission. With hot water temperature control, the chiller can be used as a heating source or cooling source. This feature provides greater application flexibility. In this case, the operator selects a hot water temperature and the chiller capacity is modulated to maintain the hot water setpoint. Heating is the primary mission and cooling is a waste product or is a secondary mission. This type of operation requires an endless source of evaporator load (heat), such as well or lake water. The chiller has only one condenser.

Note: Hot Water Temperature Control mode does NOT convert the chiller to a heat pump. Heat pump refers to the capability to change from a cooling-driven application to a heating-driven application by changing the refrigerant path on the chiller. This is impractical for centrifugal chillers as it would be much easier to switch over the water side.

This is NOT heat recovery. Although this feature could be used to recover heat in some form, a heat recovery unit has a second heat exchanger on the condenser side.

The Tracer® Symbio™ 800 provides the Hot Water Temperature Control mode as standard. The leaving condenser water temperature is controlled to a hot water setpoint between 80°F and 140°F (26.7°C and 60.0°C). The leaving evaporator water temperature is left to drift to satisfy the heating load of the condenser. In this application, the evaporator is normally piped into a lake, well, or other source of constant temperature water for the purpose of extracting heat. In Hot Water Temperature Control mode, all the limit modes and diagnostics operate as in normal cooling with one exception: the leaving



Start-Up and Shutdown

condenser water temperature sensor is an MMR diagnostic when in Hot Water Temperature Control mode. (It is an informational warning in the Normal Cooling mode.)

In the Hot Water Temperature Control mode, the differential-to-start and differential-to-stop setpoints are used with respect to the hot water setpoint instead of with the chilled water setpoint. The control panel provides a separate entry at the Tracer AdaptiView™ to set the hot water setpoint; Tracer® TU is also able to set the hot water setpoint. In the Hot Water mode, the external chilled water setpoint is the external hot water setpoint; that is, a single analog input is shared at the 1A16-J2-5 to 6 (ground).

An external binary input to select external Hot Water Control mode is on the EXOP OPTIONAL module 1A18 terminals J2-3 to J2-4 (ground). Tracer Symbio 800 also has a binary input to select chilled water control or hot water temperature control. There is no additional leaving hot water temperature cutout; the HPC and condenser limit provide for high temperature and pressure protection.

In Hot Water Temperature Control, the softloading pulldown rate limit operates as a softloading pullup rate limit. The setpoint for setting the temperature rate limit is the same setpoint for normal cooling as it is for hot water temperature control.

The factory set PID tuning values for the leaving water temperature control are the same settings for both normal cooling and hot water temperature control.

Heat Recovery Cycle

Heat recovery is designed to salvage the heat that is normally rejected to the atmosphere through the cooling tower and put it to beneficial use. For example, a high-rise office building may require simultaneous heating and cooling during the winter months. With the addition of a heat recovery cycle, heat removed from the building cooling load can be transferred to areas of the building that require heat.

Note: *The heat recovery cycle is possible only if a cooling load exists to act as a heat source.*

To provide a heat recovery cycle, a heat-recovery condenser is added to the unit. Though physically identical to the standard cooling condenser, the heat-recovery condenser is piped into a heat circuit rather than to the cooling tower. During the heat recovery cycle, the unit operates just as it does in the cooling only mode except that the cooling load heat is rejected to the heating water circuit rather than to the cooling tower water circuit. When hot water is required, the heating water circuit pumps energize. Water circulated through the heat-recovery (or auxiliary) condenser tube bundle by the pumps absorbs cooling load from the compressed refrigerant gas discharged by the compressor. The heated water is then used to satisfy heating requirements.

An optional heat recovery water flow switch and heat recovery water flow measurement is available.

Auxiliary Condensers

Unlike the heat-recovery condenser (which is designed to satisfy comfort heating requirements), the auxiliary condenser serves a preheat function only and is used in those applications where hot water is needed for use in kitchens, lavatories, etc. While the operation of the auxiliary condenser is physically identical to that of the heat-recovery condenser, it is comparatively smaller in size and its heating capacity is not controlled. Trane does not recommend operating the auxiliary condenser alone because of its small size.

An optional aux condenser water flow switch and heat recovery water flow measurement is available.

Control Panel Devices and Unit-Mounted Devices

Unit Control Panel

Safety and operating controls are housed in the unit control panel, the starter panel, and the purge control panel. The control panel operator interface is called Tracer® AdaptiView™ and is located on an adjustable arm connected to the base of the control panel. For more information about operating Tracer® AdaptiView™, see *AdaptiView™ Display with Symbio™ Controls CenTraVac® Water-Cooled Chillers, User Guide* (CTV-SVU004*-EN). For more information on the Symbio™ 800 controller, see *Symbio™ 800 Controller Installation, Operation, and Maintenance* (BAS-SVX080*-EN).

The control panel houses several other controls modules called panel-mounted Low Level Intelligent Devices (LLIDs), power supply, terminal block, fuse, circuit breakers, and transformer. The inter-processor communication (IPC) bus allows the communications between LLIDs and the controller. Unit-mounted devices are called frame-mounted LLIDs and can be temperature sensors or pressure transducers. These and other functional switches provide analog and binary inputs to the control system.

User-defined Language Support

Tracer® AdaptiView™ is capable of displaying English text or any of 26 other languages (27 total languages). Switching languages is simply accomplished from a Language Settings menu. The following languages are available:

- Arabic (Gulf Regions)
- Chinese—China
- Chinese—Taiwan
- Czech
- Dutch
- English
- French
- French (Canada)

- German
- Greek
- Hebrew
- Hungarian
- Indonesian
- Italian
- Japanese
- Korean
- Norwegian
- Polish
- Portuguese (Portugal)
- Portuguese (Brazil)
- Russian
- Romanian
- Spanish (Europe)
- Spanish (Latin America)
- Swedish
- Thai
- Turkish

Unit Start-Up and Shutdown Procedures

⚠ WARNING

Live Electrical Components!

Failure to follow all electrical safety precautions when exposed to live electrical components could result in death or serious injury.

When it is necessary to work with live electrical components, have a qualified licensed electrician or other individual who has been properly trained in handling live electrical components perform these tasks.

⚠ WARNING

Toxic Hazards!

A significant release of refrigerant into a confined space due to a rupture disk failure could displace available oxygen to breathe and cause possible asphyxiation. Failure to follow instructions below could result in death or serious injury.

Should a rupture disk fail, evacuate the area immediately and contact the appropriate rescue or response authority.

While the unit is off, do not allow the chiller to exceed 110°F (43.3°C). Failure to prevent high chiller temperature will cause the inside pressure to rise:

- Do not run evaporator water pump longer than 30 minutes after the chiller is shut down.
 - Ensure that the evaporator is isolated from the hot water loop before changeover to heating mode.
- The rupture disk is designed to relieve and discharge the refrigerant from the unit if the pressure in the evaporator exceeds 15 psig (103.4 kPaG).

Daily Unit Start-Up

1. Verify the chilled water pump and condenser water pump starter are in ON or AUTO.
2. Verify the cooling tower is in ON or AUTO.
3. Check the oil tank oil level; the level must be visible in or above the lower sight glass. Also, check the oil tank temperature; normal oil tank temperature before start-up is 140°F to 145°F (60.0°C to 62.8°C).

Notes:

- The oil heater is energized during the compressor off cycle. During unit operation, the oil tank heater may be de-energized.
- If the chiller is equipped with the free cooling option, ensure that the free cooling option is disabled in the Chiller Settings menu.

4. Check the chilled water setpoint and readjust it, if necessary, in the Chiller Settings menu.
5. If necessary, readjust the demand limit setpoint in the Chiller Setpoints menu.
6. Press AUTO.

The control panel also checks compressor motor winding temperature and a start is initiated after a minimum restart inhibit time if the winding temperature is less than 265°F (129.4°C). The chilled water pump relay is energized and evaporator water flow is proven. Next, the control panel checks the leaving evaporator water temperature and compares it to the chilled water setpoint. If the difference between these values is less than the start differential setpoint, cooling is not needed.

If the control panel determines that the difference between the evaporator leaving water temperature and chilled water setpoint exceeds the start differential setpoint, the unit



Start-Up and Shutdown

enters the initiate Start Mode and the oil and refrigerant pump and the condenser water pump are started. If flow is not initially established within 4 minutes 15 seconds of the condenser pump relay energization, an automatically resetting diagnostic “Condenser Water Flow Overdue” shall be generated, which terminates the prestart mode and de-energizes the condenser water pump relay. This diagnostic is automatically reset if flow is established at any later time.

Note: *This diagnostic does NOT automatically reset if Tracer® Symbio™ 800 is in control of the condenser pump through its condenser pump relay, since it is commanded off at the time of the diagnostic. It may reset and allow normal chiller operation if the pump was controlled from some external source.*

When less than 5 seconds remain on the restart inhibit, the pre-start starter test is conducted on wye-delta starters. If faults are detected, the unit’s compressor will not start and a diagnostic will be generated. If the compressor motor starts and accelerates successfully, Running appears on the display. If the purge is set to AUTO, the purge will start running and will run as long as the chiller is running.

Note: *If a manual reset diagnostic condition is detected during start-up, unit operation will be locked out and a manual reset is required before the start-up sequence can begin again. If the fault condition has not cleared, the control panel will not permit restart.*

When the cooling requirement is satisfied, the control panel originates a Shutting down signal. The inlet guide vanes are driven closed for 50 seconds, the compressor stops, and the unit enters a 3-minute post-lube period. The evaporator pump may continue to run for the amount of time set using Tracer® AdaptiView™.

After the post-lube cycle is done, the unit returns to auto mode.

Seasonal Unit Start-Up

1. Close all drain valves and reinstall the drain plugs in the evaporator and condenser headers.
2. Service the auxiliary equipment according to the start-up and maintenance instructions provided by the respective equipment manufacturers.
3. Fill and vent the cooling tower, if used, as well as the condenser and piping. At this point, all air must be removed from the system (including each pass). Then, close the vents in the condenser waterboxes.
4. Open all of the valves in the evaporator chilled water circuit.
5. If the evaporator was previously drained, fill and vent the evaporator and chilled water circuit. After all air is removed from the system (including each pass), close the vent valves in the evaporator waterboxes.
6. Lubricate the external vane control linkage as needed.
7. Check the adjustment and operation of each safety and operating control.
8. Close all disconnect switches.

9. Perform instructions listed in “Daily Unit Start-Up,” p. 85.

Daily Unit Shutdown

Note: *Also refer to the figure (satisfied setpoint) in .*

1. Press STOP.
2. After compressor and water pumps shutdown, the operator may turn Pump Contactors to OFF or open pump disconnects.

Seasonal Unit Shutdown

Important: *Control power disconnect switch must remain closed to allow oil sump heater operation. Failure to do this will allow refrigerant to condense in the oil pump.*

1. Open all disconnect switches except the control power disconnect switch.
2. Drain the condenser piping and cooling tower, if used. Rinse with clean water.
3. Remove the drain and vent plugs from the condenser headers to drain the condenser. Air-dry bundle of residual water.
4. Once the unit is secured for the season, the maintenance procedures described in “Normal Operation,” p. 87 (tables for recommended maintenance of standard and optional features) should be performed by qualified Trane service technicians.

Note: *During extended shutdown periods, be sure to operate the purge unit for a two-hour period every two weeks. This will prevent the accumulation of air and non-condensables in the machine. To start the purge, change the purge mode to ON in the unit control “Settings Purge” menu. Remember to turn the purge mode to “Adaptive” after the two-hour run time.*



Recommended Maintenance

⚠ WARNING

Hazardous Voltage w/Capacitors!

Failure to disconnect power and discharge capacitors before servicing could result in death or serious injury.

Disconnect all electric power, including remote disconnects and discharge all motor start/run capacitors before servicing. Follow proper lockout/tagout procedures to ensure the power cannot be inadvertently energized. For variable frequency drives or other energy storing components provided by Trane or others, refer to the appropriate manufacturer's literature for allowable waiting periods for discharge of capacitors. Verify with a CAT III or IV voltmeter rated per NFPA 70E that all capacitors have discharged.

NOTICE

Check Purge Run-Time for Unit Hermetic Integrity!

Failure to follow instructions below could result in chiller damage.

If frequent purging is required, monitor purge pumpout rate, and identify and correct source of air or water leak as soon as possible to prevent moisture contamination caused by leakage.

NOTICE

Do Not Use Non-Compatible Parts or Materials!

Use of non-compatible parts or materials could result in equipment damage.

Only genuine Trane® replacement components with identical Trane part numbers should be used in Trane CenTraVac chillers. Trane assumes no responsibility for damages resulting from the use of non-compatible parts or materials.

This section describes the basic chiller preventive maintenance procedures, and recommends the intervals at which these procedures should be performed. Use of a periodic maintenance program is important to ensure the best possible performance and efficiency from a CenTraVac® chiller.

For R-514A chillers, recommended purge maintenance procedures are detailed in *Purge System for Water-Cooled CenTraVac® Chillers with Symbio™ Control, R-514A Refrigerant Installation, Operation, and Maintenance* (PRGG-SVX002*-EN).

Record Keeping Forms

An important aspect of the chiller maintenance program is the regular completion of records. Refer to [“Appendix A: Forms and Check Sheets,” p. 97](#) for copies of the recommended forms. When filled out accurately by the machine operator, the completed logs can be reviewed to identify any developing trends in the chiller's operating conditions. For example, if the machine operator notices a gradual increase in condensing pressure during a month's time, she can systematically check and then correct the possible cause of this condition.

Normal Operation

Table 23. Normal operation

Operating Characteristic	Normal Reading
Approximate Evaporator Pressure	6 to 9 psia (41.4 to 62.1 kPaA) / -9 to -6 psig (-62.1 to -41.4 kPaG)
Approximate Condenser Pressure ^(a) , ^(b)	17 to 27 psia (117.2 to 182.2 kPaA) / 2 to 12 psig (13.8 to 82.7 kPaG) (standard condenser)
Oil Sump Temperature Unit not running	140°F to 176°F (60.0°C to 80.0°C)
Oil Sump Temperature Unit running	95°F to 162°F (35.0°C to 72.2°C)
Oil Sump Differential Oil Pressure ^(c)	18 to 22 psid (124.1 to 151.7 kPaD)

^(a) Condenser pressure is dependent on condenser water temperature, and should equal the saturation pressure of the refrigerant at a temperature above that of leaving condenser water at full load.

^(b) Normal pressure readings for ASME condenser exceed 12 psig (82.7 kPaG).

^(c) Oil tank pressure: -9 to -6 psig (-62.1 to -41.4 kPaG). Discharge oil pressure: 7 to 15 psig (48.3 to 103.4 kPaG).



Recommended Maintenance

NOTICE

Equipment Damage!

Failure to remove the strain relief with the sensor could result in equipment damage.

Do NOT attempt to pull sensor bulb through the strain relief; always remove the entire strain relief with the sensor.

Table 24. Recommended maintenance

Daily	Every 3 months	Every 6 months	Annually ^(a) - ^(b)
Check the chiller's evaporator and condenser pressures, oil tank pressure, differential oil pressure, and discharge oil pressure. Compare the readings with the values provided in the preceding table.	—	—	—
Check the oil level in the chiller oil sump using the two sight glasses provided in the oil sump head. When the unit is operating, the oil level should be visible in the lower sight glass.	—	—	—
Complete logs on a daily basis.	—	—	—
—	Clean all water strainers in the water piping system.	—	—
—	—	Lubricate the vane control linkage bearings, ball joints, and pivot points.	—
—	—	Lubricate vane operator tang O-rings.	—
—	—	Operate the tang operators manually and check for any abnormalities.	—
—	—	Lubricate the oil filter shutoff valve O-rings.	—
—	—	Drain contents of the rupture disk and purge discharge vent-line drip-leg into an evacuated waste container. Do this more often if the purge is operated excessively. Apply oil to any exposed metal parts to prevent rust.	—
—	—	—	Shutdown the chiller once each year to check the items listed on the "Appendix D: CenTraVac® Chiller Annual Inspection List," p. 102 (refer to "Appendix A: Forms and Check Sheets," p. 97).
—	—	—	For R-514A chillers, perform the annual maintenance procedures referred to in <i>Purge System for Water-Cooled CenTraVac® Chillers with Symbio™ Control, R-514A Refrigerant, Installation, Operation, and Maintenance</i> (PRGG-SVX002*-EN).
—	—	—	Use an ice water bath to verify the accuracy of the evaporator refrigerant temperature sensor (4R10). If the sensor is exposed to temperature extremes outside its normal operating range (0°F to 90°F [-17.8°C to 32.2°C]), check its accuracy at six-month intervals.
—	—	—	Inspect the condenser tubes for fouling; clean if necessary.
—	—	—	Inspect and clean the ifm efector® flow detection sensors. Use Scotch-Brite® or other non-abrasive material to clean scale; do NOT use steel wool, which could cause the probe to rust.
—	—	—	Submit a sample of the compressor oil to a Trane-qualified laboratory for comprehensive analysis.
—	—	—	Measure the compressor motor winding resistance to ground; a qualified service technician should conduct this check to ensure that the findings are properly interpreted. Contact a qualified service organization to leak-test the chiller; this procedure is especially important if the system requires frequent purging.

^(a) Every three years, use a non-destructive tube test to inspect the condenser and evaporator tubes. It may be desirable to perform tube tests on these components at more frequent intervals depending upon chiller application. This is especially true of critical process equipment. Ask your Sales account manager for a copy of engineering bulletin (CTV-PRB024*-EN) for clarification of the role of eddy current testing in chiller maintenance by providing information about eddy current technology and heat exchanger tubing.

Table 24. Recommended maintenance (continued)

(b) Contact a qualified service organization to determine when to conduct a complete examination of the unit to discern the condition of the compressor and internal components. Check the following: chronic air leaks (which can cause acidic conditions in the compressor oil and result in premature bearing wear) and evaporator or condenser water tube leaks (water mixed with the compressor oil can result in bearing pitting, corrosion, or excessive wear).

Table 25. Recommended maintenance of optional features

Feature	Every 3 months	Every 6 months	Annually
Waterbox Coatings	Inspect waterbox coatings within the first 1 to 3 months to determine a required maintenance schedule for your job site. See "Waterbox and Tubesheet Protective Coatings," p. 92 for more information.	—	—
Waterbox Anodes	Inspect waterbox anodes within the first 1 to 3 months to determine a required maintenance schedule for your job site. See "Sacrificial Anodes," p. 92 for more information.	—	—
Gantries	—	—	Lubricate the gantries annually. Use ConocoPhillips MegaPlex® XD3 (gray in color), LPS® MultiPlex Multi-Purpose (blue in color), or equivalent.
Hinges	—	—	Lubricate the hinges annually. Use ConocoPhillips MegaPlex® XD3 (gray in color), LPS® MultiPlex Multi-Purpose (blue in color), or equivalent.

Recommended Compressor Oil Change

NOTICE

Equipment Damage!

Mixing refrigerants or oils could result in equipment damage including bearing damage, introduction of acids into the chiller, or continuous purge pump-out in high-head/high ambient applications.

CenTraVac™ chillers are manufactured with different refrigerant/oil systems: 1) chillers using R-123 refrigerant and OIL00022 compressor oil, and 2) chillers using R-514A refrigerant and various Trane POE-based compressor oils.

Always verify proper refrigerant and oil for your chiller. Do NOT mix refrigerants and oils.

This *Installation, Operation, and Maintenance* manual applies to CenTraVac® chillers with two different refrigerant and compressor oil systems:

- R-123 refrigerant and OIL00022 compressor oil.
- R-514A refrigerant and Trane OIL00379/OIL00380 compressor oil.

NOTICE

Equipment Damage!

Failure to follow instructions below could result in equipment damage.

Follow oil use instructions for post-service compressor air-run procedures.

For post-service compressor air-run procedures on CenTraVac® chillers that use R-514A refrigerant and POE oil:

1. Use Trane OIL00381/OIL00382 compressor oil for the air-run procedure.

2. Upon completion of the air-run procedure, drain the OIL00381/OIL00382 from the sump.
3. After unit final assembly and evacuation, refill the sump with Trane OIL00379/OIL00380.

Important: *Verify proper refrigerant and compressor oil for your chiller before proceeding!*

After the first six months of accumulated operation or after 1000 hours operation—which ever comes first—it is recommended to change the oil and filter. After this oil change, it is recommended to subscribe to the Trane annual oil analysis program rather than automatically change the oil as part of scheduled maintenance. Change the oil only if indicated by the oil analysis. Using an oil analysis program will reduce the chiller's overall lifetime waste oil generation and minimize refrigerant emissions. The analysis determines system moisture content, acid level, and wear metal content of the oil, and can be used as a diagnostic tool. The oil analysis should be performed by a qualified laboratory that is experienced in refrigerant and oil chemistry and in the servicing of Trane® centrifugal chillers.

In conjunction with other diagnostics performed by a qualified service technician, oil analyses can provide valuable information on the performance of the chiller to help minimize operating and maintenance costs and maximize its operating life. A valve is installed next to the oil filter for the purpose of obtaining oil samples.

Notes:

- Use only Trane compressor oil and verify proper refrigerant and oil for your chiller before proceeding! A full compressor oil change is 9 gallons (34.1L) of oil for each sump of the R-514A Duplex chiller.
 - For chillers with R-123 refrigerant, use OIL00022 (2.5 gallon [9.5 L] containers) compressor oil.
 - For chillers with R-514A refrigerant, use OIL00379 (1 gallon [3.8 L] containers)/OIL00380 (5 gallon [18.9 L] containers) compressor oil.
 - For air-run operation use OIL00381 (1 gallon [3.8L] containers)/OIL00382 (5 gallon [18.9L] containers) compressor oil.
- One spare compressor oil filter is provided with each new chiller. If not used earlier, use at first recommended compressor oil and filter change.
- This recommended compressor oil change is NOT covered by factory warranty.

Purge System

The use of low-pressure refrigerant in CenTraVac® chillers permits any section of the unit to be below atmospheric pressure, regardless of whether the unit is running. This creates an environment in which air or moisture could enter the unit. If these non-condensables are allowed to accumulate while the chiller is running, they become trapped in the condenser; this situation increases condensing pressure and compressor power requirements, and reduces the chiller's efficiency and cooling capacity. Therefore, proper maintenance of the purge system is required.

The purge is designed to remove non-condensable gases and water from the refrigeration system. For R-514A chillers, operation, maintenance, and troubleshooting procedures are detailed in *Purge System for Water-Cooled CenTraVac® Chillers with Symbio™ Control, R-514A Refrigerant, Installation, Operation, and Maintenance* (PRGG-SVX002*-EN).

Leak Checking Based on Purge Pump Out Time

Use the following formula to calculate the annual refrigerant leakage rate based on the daily purge pump-out time and the unit refrigerant charge.

Formula: % annual leakage rate = $[(X \text{ min/day}) \cdot (0.0001 \text{ lb of refrigerant/min}) / (Y \text{ lb})] \cdot 100$

- X = minutes/day of purge pump out operation
- Y = initial refrigerant charge

The following figure has been developed to aid in determining when to do a leak check of a chiller based on the purge pump-out time and unit size. This figure depicts

normal purge pump-out times, small leaks, and large leaks based on chiller tonnage.

If the purge pump-out time is in the small leak region, then a leak check should be performed and all leaks repaired at the earliest convenience. If the purge pump-out time is in the large leak region, a thorough leak check of the unit should be performed immediately to find and fix the leaks.

Figure 59. Purge operation under typical and leak conditions

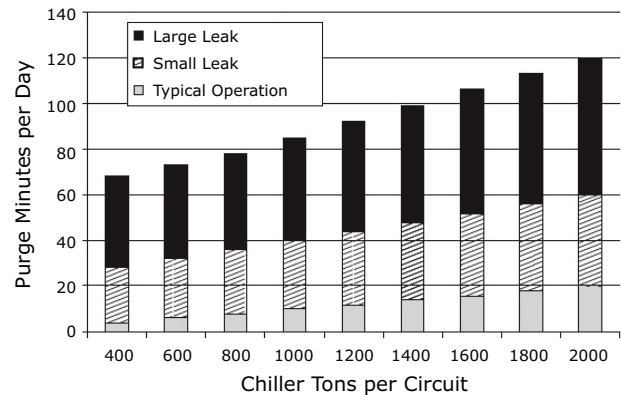

Long Term Unit Storage

If the chiller will be stored for more than six months after production, contact your local Trane Service Agency for *required* extended storage actions to minimize impact to the chiller and preserve the warranty. In addition, contact your local Trane Service Agency for recommendations for storage requirements for chillers to be removed from service in excess of a normal seasonal shutdown.

⚠ WARNING

Refrigerant May Be Under Positive Pressure!

Failure to follow instructions below could result in an explosion which could result in death or serious injury or equipment damage.

System contains refrigerant and may be under positive pressure; system may also contain oil. Recover refrigerant to relieve pressure before opening the system. See unit nameplate for refrigerant type. Do not use non-approved refrigerants, refrigerant substitutes, or non-approved refrigerant additives.

NOTICE

Equipment Damage!

Failure to protect the unit from freezing could result in equipment damage.

If fluid has been added to the piping, the unit must be protected from freezing. Freeze damage from an unheated equipment room is not the Trane company's responsibility. These are indoor units.

NOTICE

Chiller Damage!

Failure to ensure that water is not present in tubes during evacuation could result in freezing tubes, damaging the chiller.

Refrigerant Charge

⚠ WARNING

Refrigerant May Be Under Positive Pressure!

Failure to follow instructions below could result in an explosion which could result in death or serious injury or equipment damage.

System contains refrigerant and may be under positive pressure; system may also contain oil. Recover refrigerant to relieve pressure before opening the system. See unit nameplate for refrigerant type. Do not use non-approved refrigerants, refrigerant substitutes, or non-approved refrigerant additives.

NOTICE

Equipment Damage!

Mixing refrigerants or oils could result in equipment damage including bearing damage, introduction of acids into the chiller, or continuous purge pump-out in high-head/high ambient applications.

CenTraVac™ chillers are manufactured with different refrigerant/oil systems: 1) chillers using R-123 refrigerant and OIL00022 compressor oil, and 2) chillers using R-514A refrigerant and various Trane POE-based compressor oils.

Always verify proper refrigerant and oil for your chiller. Do NOT mix refrigerants and oils.

This *Installation, Operation, and Maintenance* manual applies to CenTraVac® chillers with two different refrigerant and compressor oil systems:

- R-123 refrigerant and OIL00022 compressor oil.
- R-514A refrigerant and Trane OIL00379/OIL00380 compressor oil.

NOTICE

Equipment Damage!

Failure to follow instructions below could result in equipment damage.

Follow oil use instructions for post-service compressor air-run procedures.

For post-service compressor air-run procedures on CenTraVac® chillers that use R-514A refrigerant and POE oil:

1. Use Trane OIL00381/OIL00382 compressor oil for the air-run procedure.

2. Upon completion of the air-run procedure, drain the OIL00381/OIL00382 from the sump.
3. After unit final assembly and evacuation, refill the sump with Trane OIL00379/OIL00380.

Important: Verify proper refrigerant and compressor oil for your chiller before proceeding!

For chillers with R-123 refrigerant, see *R-123 Low-Pressure Refrigerant Handling Guidelines Conservation and Safe Handling of R-123 Refrigerant in Trane Chillers for Service Technicians Installation, Operation, and Maintenance* (CTV-SVX05*-EN). For chillers with R-514A refrigerant, see *R-514A Low-Pressure Refrigerant Handling Guidelines Conservation and Safe Handling of R-514A Refrigerant in Trane Chillers for Service Technicians Installation, Operation, and Maintenance* (CTV-SVX008*-EN)

Leak Testing

⚠ WARNING

Explosion Hazard!

Failure to follow safe leak test procedures below could result in death or serious injury or equipment or property-only-damage.

Never use an open flame to detect gas leaks. Use a leak test solution for leak testing.

⚠ WARNING

Hazardous Pressures!

Failure to follow instructions below could result in a violent explosion, which could result in death or serious injury.

If a heat source is required to raise the tank pressure during removal of refrigerant from cylinders, use only warm water or heat blankets to raise the tank temperature. Do not exceed a temperature of 150°F. Do not under any circumstances apply direct flame to any portion of the cylinder.

Important: If leak testing is required, contact a Trane Service Agency.

Recommended System Maintenance

NOTICE

Proper Water Treatment Required!

The use of untreated or improperly treated water could result in scaling, erosion, corrosion, algae or slime.

Use the services of a qualified water treatment specialist to determine what water treatment, if any, is required. Trane assumes no responsibility for equipment failures which result from untreated or improperly treated water, or saline or brackish water.

Condenser

Condenser tube fouling is indicated when the approach temperature (the difference between the condensing refrigerant temperature and the leaving condenser water temperature) is higher than predicted.

If the annual condenser tube inspection indicates that the tubes are fouled, two cleaning methods—mechanical and chemical—can be used to rid the tubes of contaminants. Use the mechanical cleaning method to remove sludge and loose material from smooth-bore tubes.

To clean other types of tubes including internally-enhanced types, consult a qualified service organization for recommendations.

Figure 60. Typical chemical cleaning setup

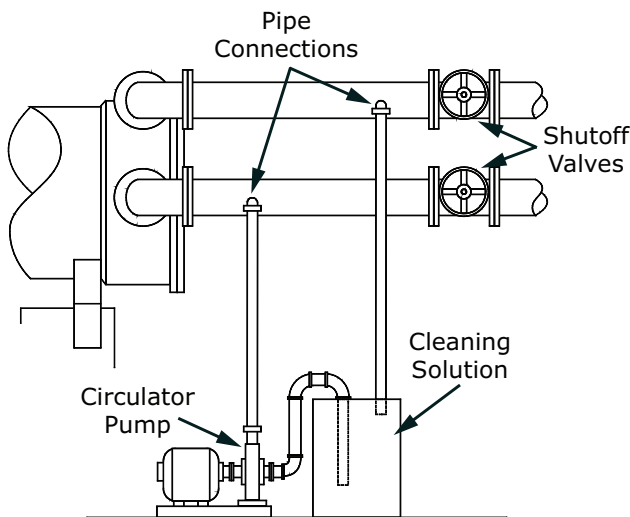

1. Follow all instructions in “[Waterbox Removal and Installation](#),” p. 94 to remove waterbox covers.
2. Work a round nylon or brass bristled brush (attached to a rod) in and out of each of the condenser water tubes to loosen the sludge.
3. Thoroughly flush the condenser water tubes with clean water.
4. Scale deposits are best removed by chemical means. Be sure to consult any qualified chemical house in the area (one familiar with the local water supply’s chemical mineral content) for a recommended cleaning solution suitable for the job.

Note: A standard condenser water circuit is composed solely of copper, cast iron, and steel.

NOTICE

Unit Corrosion Damage!

Failure to follow instructions below could result in corrosion damage to the unit and tubes.

Follow proper procedures when using corrosive chemicals to clean water side of unit. If unsure, it is recommended that the services of a qualified chemical cleaning firm be used.

Important: All of the materials used in the external circulation system, the quantity of the solution, the duration of the cleaning period, and any required safety precautions should be approved by the company furnishing the materials or performing the cleaning. Remember, however, that whenever the chemical tube cleaning method is used, it must be followed up with mechanical tube cleaning, flushing, and inspection.

Evaporator

Since the evaporator is typically part of a closed circuit, it may not accumulate appreciable amounts of scale or sludge. Normally, cleaning every three years is sufficient. However, periodic inspection and cleaning is recommended on open evaporator systems, such as air washers.

Waterbox and Tubesheet Protective Coatings

Trane recommends that coated waterboxes/tubesheets—regardless of the type of protective coating included—be taken out of service within the first one to three months of operation for inspection. Any voids or defects identified upon inspection must be repaired. If the water quality is known to be highly supportive of corrosion (i.e., sea water, etc.), inspect the coating system at one month; if the water quality is known to be relatively benign (i.e., normal treated and clean condenser water), inspect the coating system within three months. Only when initial inspections show no problems are present should subsequent maintenance intervals be increased.

Sacrificial Anodes

The replacement schedule for the optional zinc or magnesium anodes can vary greatly with the aggressiveness of the water that is in the system. Some sites could require anode replacement every two to three months while other sites may require anode replacement every two to three years. Trane recommends inspection of anodes for wear sometime within the first several months of the anodes being placed into service. If the observed loss of anode material is small, then the interval between subsequent inspections can be lengthened. Replace the anode and/or shorten the inspection interval if the anode has lost 50 percent or more of its original mass. If anode depletion occurs very quickly, consult a water treatment specialist to determine if the anode material selected is correct for the application.

NOTICE**Equipment Damage!**

Failure to follow instructions could result in equipment damage.

Do NOT use Teflon-based tape or paste on anode; a small amount of liquid sealant (Loctite® 242 or equivalent) may be applied to prevent leakage when installing an anode, but do not apply so much sealant that it prevents the necessary electrical connection between the anode and the waterbox.

As needed after draining the waterbox, use a 2-1/2 in. (63.5 mm) wrench to remove/install Trane-supplied waterbox anodes.



Waterbox Removal and Installation

Important: Only qualified technicians should perform the installation and servicing of this equipment.

Discussion

This section will discuss recommended hoist ring/clevises and lifting. Proper lifting technique will vary based on mechanical room layout.

- It is the responsibility of the person(s) performing the work to be properly trained in the safe practice of rigging, lifting, securing, and fastening of the waterbox.
- It is the responsibility of the person(s) providing and using the rigging and lifting devices to inspect these devices to ensure they are free from defect and are rated to meet or exceed the published weight of the waterbox.
- Always use rigging and lifting devices in accordance with the applicable instructions for such device.

Procedure

⚠ WARNING

Heavy Objects!

Failure to properly lift waterbox could result in death or serious injury.

Each of the individual cables (chains or slings) used to lift the waterbox must be capable of supporting the entire weight of the waterbox. The cables (chains or slings) must be rated for overhead lifting applications with an acceptable working load limit. Refer to the waterbox weights table.

Note: See “*Torque Requirements and Waterbox Weights*,” p. 95 for waterbox weights.

⚠ WARNING

Straight Vertical Lift Required!

Failure to properly lift waterbox in straight vertical lift could cause the eyebolts to break which could result in death or serious injury from object dropping.

The proper use and ratings for eyebolts can be found in ANSI/ASME standard B18.15. Maximum load rating for eyebolts are based on a straight vertical lift in a gradually increasing manner. Angular lifts will significantly lower maximum loads and should be avoided whenever possible. Loads should always be applied to eyebolts in the plane of the eye, not at some angle to this plane.

Review mechanical room limitations and determine the safest method or methods of rigging and lifting the waterboxes.

1. Determine the type and size of chiller being serviced. Refer to Trane® nameplate located on chiller control panel.

Important: This section contains rigging and lifting information only for Trane® CenTraVac™ chillers built in La Crosse. For Trane® CenTraVac™ chillers built outside the United States, refer to literature provided by the applicable manufacturing location.

2. Select the proper lift connection device from the table in “[Connection Devices Information](#),” p. 96. The rated lifting capacity of the selected lift connection device must meet or exceed the published weight of the waterbox. Verify the waterbox weight from the latest published literature.
3. Ensure that the lift connection device has the correct connection for the waterbox (e.g., thread type [course/fine, English/metric] and screw diameter [English/metric]).
4. Properly connect the lift connection device to the waterbox. See the following figure and ensure that the lift connection device is securely fastened.

Install hoist ring on to the lifting connection on the waterbox. Torque to 100 ft·lb (135.6 N·m) for 3/4-inch (19.05-mm) threaded connections and 28 ft·lb (38.0 N·m) for 1/2-inch (12.7-mm) threaded connections.

5. Disconnect water pipes, if connected.
6. Remove hex head bolts.
7. Lift the waterbox away from the shell.

⚠ WARNING

Overhead Hazard!

Failure to follow instructions could result in death or serious injuries.

Never stand below or in close proximity to heavy objects while they are suspended from, or being lifted by, a lifting device in case the object drops.

8. Store waterbox in a safe and secure location and position.

Note: Do NOT leave waterbox suspended from lifting device.

Figure 61. Waterbox rigging and lifting—condenser and evaporator connections

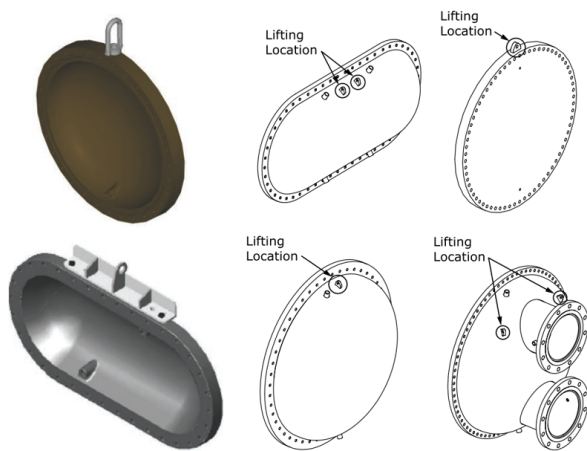

Reassembly

Once service is complete, the waterbox should be reinstalled on the shell following all previous procedures in reverse. Use new O-rings or gaskets on all joints after thoroughly cleaning each joint.

Important: Torque waterbox screws as specified in “*Torque Requirements and Waterbox Weights*,” p. 95.

Torque Requirements and Waterbox Weights

Note: These chillers are assembled with SAE fasteners.

Table 26. CenTraVac chiller screw torques — SAE

Screw Size	Torque — Gasket type O-ring		Torque — Flat	
	in	ft·lb	ft·lb	N·m
3/8	25	33.9	12–18	16.3–24.4
1/2	70	94.9	33–50	44.7–67.8
5/8	150	203.4	70–90	94.9–122.0
3/4	250	339.0	105–155	142.4–210.2



Waterbox Removal and Installation

Table 27. Waterbox weights

Shell Size	Description	Fabricated Non-Marine Waterbox, Welded Flat Plate			Non-Marine Cast Waterbox			Fabricated Non-Marine Waterbox Welded Dome			Marine Style Waterbox Cover				
		Weight		Lifting Connection	Weight		Lifting Connection	Weight		Lifting Connection	Weight		Lifting Connection		
		lb	kg		lb	kg		lb	kg		lb	kg			
032	Evaporator, 150 psig (1034.2 kPaG)	265	120	3/4 - 10	—		—		—		176	80	1/2 - 13		
	Evaporator, 300 psig (2068.4 kPaG)														
	Condenser, 150 psig (1034.2 kPaG)	—		—		176	80	1/2 - 13	—		176	80	1/2 - 13		
	Condenser, 300 psig (2068.4 kPaG)	265	120	3/4 - 10	—		—		—		221	100	1/2 - 13		
050	Evaporator, 150 psig (1034.2 kPaG)	—		—		397	180	Lifting Fixture	171	77	0.469	265	120	1/2 - 13	
	Evaporator, 300 psig (2068.4 kPaG)	—		—		—		—		167	76	0.469	265	120	1/2 - 13
	Condenser, 150 psig (1034.2 kPaG)	—		—		265	120	1/2 - 13	230	104	0.469	265	120	1/2 - 13	
	Condenser, 300 psig (2068.4 kPaG)	—		—		—		—		248	113	0.469	441	200	1/2 - 13
080	Evaporator, 150 psig (1034.2 kPaG)	—		—		662	300	Lifting Fixture	336	152	0.469	441	200	3/4 - 10	
	Evaporator, 300 psig (2068.4 kPaG)	—		—		—		—		330	150	0.469	551	250	3/4 - 10
	Condenser, 150 psig (1034.2 kPaG)	—		—		551	250	3/4 - 10	259	117	0.469	441	200	1/2 - 13	
	Condenser, 300 psig (2068.4 kPaG)	—		—		—		—		388	176	0.469	882	400	3/4 - 10
142	Evaporator, 150 psig (1034.2 kPaG)	—		—		—		—		446	202	0.469	662	300	3/4 - 10
	Evaporator, 300 psig (2068.4 kPaG)	—		—		—		—		456	207	0.469	882	400	3/4 - 10
	Condenser, 150 psig (1034.2 kPaG)	—		—		—		—		457	207	0.469	1323	600	3/4 - 10
	Condenser, 300 psig (2068.4 kPaG)	—		—		—		—		683	309	0.469	1764	800	3/4 - 10
210	Evaporator, 150 psig (1034.2 kPaG)	—		—		—		—		595	270	0.469	1323	600	3/4 - 10
	Evaporator, 300 psig (2068.4 kPaG)	1871	848	0.469	—		—		—		0.469	1764	800	3/4 - 10	
	Condenser, 150 psig (1034.2 kPaG)	—		—		—		—		588	267	0.469	1764	800	3/4 - 10
	Condenser, 300 psig (2068.4 kPaG)	—		—		—		—		985	446	0.469	2426	1100	3/4 - 10
250	Evaporator, 150 psig (1034.2 kPaG)	—		—		—		—		726	329	0.469	1544	700	3/4 - 10
	Evaporator, 300 psig (2068.4 kPaG)	—		—		—		—		1274	577	0.469	2205	1000	3/4 - 10
	Condenser, 150 psig (1034.2 kPaG)	—		—		—		—		644	292	0.469	2205	1000	3/4 - 10
	Condenser, 300 psig (2068.4 kPaG)	—		—		—		—		1273	577	0.469	3087	1400	3/4 - 10

Note: Refer to product block identifier on the model number plate which identifies the evaporator and condenser shell sizes and the rated pressure. The designators are as follows:

Weights shown are maximum for waterbox size. Verify the waterbox from the latest published literature.

Connection Devices Information

Table 28. Connection devices

Unit	Product	Part Number	Order Information
CTV	Safety Hoist Ring 3/4-10	RNG01884	Contact Trane Parts Department
CTV	Safety Hoist Ring 1/2-13	RNG01885	Contact Trane Parts Department
CTV	Evap Lifting Fixture	BAR00400	Contact Trane Parts Department



Appendix A: Forms and Check Sheets

The following forms and check sheets are included for use with Trane start-up of CVHE, CVHF, and CVHG CenTraVac® chillers. Forms and check sheets are used, as appropriate, for installation completion verification before Trane start-up is scheduled, and for reference during the Trane start-up.

Where the form or check sheet also exists outside of this publication as standalone literature, the literature order number is also listed.

- CTV Form — *Installation Completion and Request for Trane Service* (CTV-ADF001*-EN)
- CenTraVac Chiller Start-up Tasks to be Performed by Trane
- CenTraVac Chiller Annual Inspection List
- CenTraVac Operator Log

Unit Start-Up/Commissioning

Important: *Start-up must be performed by Trane or an agent of Trane specifically authorized to perform start-up and warranty of Trane® products. Contractor shall provide Trane (or an agent of Trane specifically authorized to perform start-up) with notice of the scheduled start-up at least two weeks prior to the scheduled start-up.*



Appendix B: Chiller Installation Completion and Request for Trane Service

Important: A copy of this completed form must be submitted to the Trane Service Agency that will be responsible for the start-up of the chiller. Start-up will NOT proceed unless applicable items listed in this form have been satisfactorily completed.

To: _____

Trane Service Office: _____

S.O. Number: _____

Serial Numbers: _____

Job/Project Name: _____

Address: _____

The following items are being installed and will be completed by: _____

Important: Start-up must be performed by Trane or an agent of Trane specifically authorized to perform start-up and warranty of Trane® products. Contractor shall provide Trane (or an agent of Trane specifically authorized to perform start-up) with notice of the scheduled start-up at least two weeks prior to the scheduled start-up. **Equipment not started by Trane is not warranted by Trane.**

Notes: Improper installation of CenTraVac® chillers, including optional components, can result in start-up delay and required rework. Follow all provided instructions and in use particular care with optional devices:

- Follow installation procedures for RuptureGuard™; refer to CTV-SVX06*-EN for CDHF, CDHG, CVHE, CVHF, CVHG, and CVHM models, refer to CDHH-SVX003*-EN for CDHH models, and refer to CVHH-SVX003*-EN for CVHH CenTraVac chiller models.
 - Do NOT over-insert or over-torque the probe of the ifm efector™ flow detection controller and sensor; refer to PART-SVN223*-EN or the CenTraVac chiller Installation, Operation, and Maintenance manual.
 - Do NOT block serviceable parts when installing isolation springs.
- Expenses that result in improper installation of CenTraVac chillers, including optional components, will NOT be paid by Trane.

Check box if the task is complete or if the answer is "yes".

1. Chiller

- In place and piped.

Note: Do not insulate the CenTraVac chiller or adjacent piping prior to the chiller commissioning by Trane service personnel. The contractor is responsible for any foreign material left in the unit.

2. Piping

Chilled water piping connected to:

- CenTraVac chiller
- Air handling units
- Pumps
- Optional ifm efector® flow detection controller and sensor properly installed

Condenser and heat recovery condenser (as applicable) piping connected to:

- CenTraVac chiller
- Pumps
- Cooling tower
- Heating loop (as applicable)

Additional piping:

- Make-up water connected to cooling tower
- Water supply connected to filling system
- Systems filled
- Pumps run, air bled from system
- Strainers cleaned
- Rupture disk or RuptureGuard™ ventilation piping properly installed
- Optional RuptureGuard™ properly installed

3. Flow balancing valves installed

- Leaving chilled water
- Leaving condenser water
- Optional heat recovery or auxiliary condenser water

4. Gauges, thermometers, and air vents

- Installed on both sides of evaporator
- Installed on both sides of condenser and heat recovery condenser (as applicable)

5. Wiring

- Compressor motor starter has been furnished by Trane, or has been configured and installed in compliance with the appropriate Trane Engineering Specification for Starter by Others (available from your local Trane Sales Office)

Appendix B: Chiller Installation Completion and Request for Trane Service

- Full power available
- Interconnecting wiring, starter to panel (as required)
- External interlocks (flow switch, pumps auxiliary, etc.)
- Chiller motor connection (remote starters)

Note: Do not make final remote starter-to compressor motor connections until requested to do so by the Trane service representative!

- Chilled water pump (connected and tested)
- Condenser water pump (connected and tested)
- Optional ifm efector® flow detection controller and sensor cable properly installed and secured for non-stress at probe connector
- Cooling tower fan rotation checked
- Heat recovery condenser water pump (as applicable)
- 115 Vac power available for service tools
- All controls installed and connected
- Indicate type of power distribution grounding
- All magnetic starters installed and connected

6. Testing

- Dry nitrogen available for pressure testing (for disassembled units)
- Material and equipment available for leak testing (if necessary)

7. Refrigerant

- For CDHH and CVHH chillers: Verify supplied refrigerant is "Solstice ZD" Refrigeration Grade by checking certificates provided with tanks.
- Refrigerant on job site and in close proximity to chiller

Total amount in cylinders/drums: _____
(specify lb or kg) and fill in specifics below:

Number of cylinders/drums _____ of size _____
(specify lb or kg)

Number of cylinders/drums _____ of size _____
(specify lb or kg)

Note: After commissioning is complete, it is the installer's responsibility to transport empty refrigerant containers to an easily accessible point of loading to facilitate container return or recycling.

8. System

- Systems can be operated under load conditions.

9. Availability

- Electrical, control personnel, and contractor's representative are available to evacuate, charge, and test the CenTraVac® chiller under serviceman's supervision.

10. Equipment room

- Does the equipment room have a refrigerant monitor/sensor capable of monitoring and alarming within the allowable exposure level of the refrigerant?
- Does the installation have properly placed and operating audible and visual refrigerant alarms?
- Does the equipment room have proper mechanical ventilation?
- If it is required by local code, is a self-contained breathing apparatus available?

11. Owner awareness

- Has the owner been fully instructed on the proper use and handling of refrigerant?
- Does the owner have a copy of the MSDS for refrigerant?

Note: Additional time required to properly complete the start-up and commissioning, due to any incompleteness of the installation, will be invoiced at prevailing rates.

This is to certify that the Trane equipment has been properly and completely installed, and that the applicable items listed above have been satisfactorily completed.

Checklist completed by:
(Print Name): _____

Signed: _____

Date: _____

In accordance with your quotation and our purchase order number _____, we therefore require the presence of Trane service on this site, for the purpose of start-up and commissioning, by _____ (date).

Note: Minimum of two week advance notification is required to allow for scheduling of the chiller start-up.

Additional Comments/Instructions:



Appendix C: CenTraVac® Chiller Start-Up Tasks to be Performed by Trane

⚠ WARNING

Safety Alert!

Failure to follow instructions below could result in death or serious injury.

In addition to the following tasks, you **MUST**:

- Follow all instructions in the unit's *Installation, Operation, and Maintenance* manual, including warnings, cautions, and notices.
- Perform all required tasks in any applicable Service Alerts and Service Bulletins.
- Review and understand all information provided in Submittals and Design Specifications.

1. General

- Inspect chiller for damage (shipping or rigging).
- Verify and record unit nitrogen holding charge pressure.
- Inspect water piping for proper installation.
 - Inspect strainers, flow sensing devices, isolation valves, pressure gauges, thermometer wells, flow balancing valves, vent cocks, and drains.
 - Inspect cooling tower piping.
- Verify proper clearances.
- Power wiring meets size requirement.
 - Verify proper voltage and amperage rating.
- Verify proper foundation installation.
- Verify unit isolator pads/springs have been installed.
- Verify low voltage circuits are isolated from high voltage circuits.
- Check equipment room for ventilation, refrigerant monitor, rupture disk piping, and Personal Protective Equipment (PPE).

Note: All conditions which do not conform to the established requirements for unit installation **MUST** be corrected prior to start-up. Any non-conforming condition which is not corrected prior to start-up must be noted in the Non-Compliance Form (PROD-ADF001*-EN) by the start-up technician; this information must also be signed by responsible site personnel before start-up and the completed Non-Compliance Form will become part of the start-up record, submitted with a Start-up Check Sheet and a Chiller Service Report.

2. Pre-Start Operations

- Verify nitrogen holding charge.
- Calibrate the high pressure cutout control (HPC).
- Meg compressor motor.
- Confirm proper oil pump operation.
- Evacuate unit.
- Check condenser installation.
- Check evaporator installation.

NOTICE

Do Not Apply Electrical Power to a Unit in a Vacuum!

Failure to follow instructions below could result in motor and compressor damage.

Do not apply electrical power to a motor in a vacuum.

For units with inside-the-delta solid state starters, disconnect power to unit during evacuation or when the unit is in a deep vacuum. In addition, on units with inside-the-delta solid state starters, all power to the unit must be disconnected prior to evacuating the unit as line power is directly applied to the motor terminals 4, 5, and 6.

- Check electrical and controls.
 - Inspect motor starter and control panel.
 - Confirm all wiring connections are tight, free of abrasion and have no sharp bends in panel and on compressors.
 - Inspect contactors and relays.
 - Verify unit wiring (low and high voltage) is correctly isolated, phased, and properly grounded.
 - Connect external 120 Vac power to power up the control panel.
 - Run the oil pump to verify pump can provide 18 to 22 psid (124.1 to 151.7 kPaD) net pressure.
 - Verify and record control parameters.
 - Verify all control interlocks are installed and properly functioning.
 - Set AFD grounding jumpers (PE-A for MOV and PEB for Common Mode) for power distribution grounding:
 - Both jumpers "Connected" for Solidly Grounded System (Center Ground Wye).

Appendix C: CenTraVac® Chiller Start-Up Tasks to be Performed by Trane

- Both jumpers “Disconnected” for Non Solidly Grounded System (Any Delta, High Impedance Ground, or Ungrounded Wye).

Note: Refer to AFD-SVG002*-EN for more information.

- Dry run starter (non-Adaptive Frequency™ Drive [AFD]).
- Measure condenser pressures and flow.
- Adjust condenser flow sensing device.
- Measure evaporator pressures and flow.
- Adjust evaporator flow sensing device.
- Measure optional heat recovery pressures and flow.
- Adjust optional heat recovery flow sensing device.
- Inspect motor starter panel and perform starter panel checkout procedures.
- Confirm proper phase check incoming power.
- Inspect control panel.
- Apply separate source 120 Vac power to control to perform control panel checkout procedure.
- Review and record unit configuration parameters.
- Confirm oil pump pressure—regulating valve setting.
- Verify vane operator is working properly and moves without binding.
- Dry run test starter (non-AFD).
- Remove separate source power and reconnect wiring.
- Install optional Air-Fi and/or Wi-Fi modules.

3. Preparation for Start-up

- Relieve nitrogen holding charge.
- Evacuate and charge the system.
- Apply power to the starter panel.
- Verify current to the oil sump heater.

4. Chiller Start-up

- Set Purge mode to “On.”
- Bump-start the compressor and verify compressor motor rotation.
- Start chiller.
- Verify no unusual noises or vibrations and observe operating conditions.
- If necessary, adjust oil pressure regulator between 18 to 22 psid (124.1 to 151.7 kPaD) net.
- Measure and verify refrigerant pump pressure.
- When chiller is stable, take system log three times at 15-minute intervals.
- Set Purge mode to “Adaptive.”
- Reset the “Starter Energy Consumption” resettable.
- Record a *Chiller Service Report*.

- Review “AdaptiView Display Customer Training Checklist.”

- Equipment Description
- Stopping/Starting Chiller Operation
- Alarms
- Reports
- Data Graphs
- Equipment Settings
- Display Settings
- Security Settings
- Basic Troubleshooting



Appendix D: CenTraVac® Chiller Annual Inspection List

Follow the annual maintenance instructions provided in the text of this manual, including but not limited to:

1. Compressor/Motor

- Motor continuity.
- Motor meg test.
- Check motor terminals.
- Inspect motor terminal board.
- Check inlet guide vanes (IGV) for abnormalities.

2. Starter or Adaptive Frequency™ Drive

- Inspect starter contacts.
- Check all connections per manufacturer specifications.
- Follow all manufacturer recommendations for starter or Adaptive Frequency™ Drive (AFD) maintenance.
- Inspect/clean/service the AFD cooling system (water- or air-cooled AFD).
- Record all applicable starter or starter component settings.

3. Oil System

- Annual oil analysis (follow recommendations).
- Clean and lubricate oil system as required.
- Electrical inspection.
- Pump motor continuity check.
- Run oil pump and check differential oil pressure.

4. Condenser

- Inspect for fouling and scaling in tubes.
- Check operation of condenser water flow sensing device.
- Factory recommendation to eddy current test tubes every three years.

5. Evaporator

- Inspect for fouling and scaling in tubes.
- Check operation of evaporator water flow sensing device.
- Factory recommendation to eddy current test tubes every three years.

6. Heat Recovery

- Inspect for fouling and scaling in tubes.
- Check operation of heat recovery water flow sensing device.
- Factory recommendation to eddy current test tubes every three years.

7. Control Circuits

- Verify control parameters.

- Test appropriate sensors for accuracy.
- Ensure sensors are properly seated in wells with thermopaste installed.
- Check evaporator leaving water temperature low temperature cutout setpoint.
- Condenser high pressure switch check-out.
- Check adjustment and operation of the inlet guide vane actuator.

8. Leak Test Chiller

- Check purge times and unit performance logs. If warranted, pressure leak test.
- Review oil analysis. If required, submit refrigerant sample for analysis.
- Inspect unit for any signs of refrigerant or oil leakage.
- Check unit for any loose screws on flange, volutes, or casing.

9. Purge Unit

- Review the purge *Installation, Operation, and Maintenance* manual and follow maintenance and/or inspection items identified.
- Review purge pump-out data.
- Review overall operation of purge and service as necessary.

10. Exterior

- Inlet guide vane linkage.
- Clean and touch-up painted surfaces as needed.
- Repair deteriorated, torn, or missing insulation.

11. Optional Accessories

- If applicable, lubricate factory-installed gantries.
- After the first month of operation, inspect Heresite® or Belzona® coated waterboxes; thereafter, inspect as needed.
- Inspect anodes.
- Inspect and lubricate hinged waterboxes.
- With water flow sensing option, bleed tubing from waterboxes to transformers.



Appendix E: CenTraVac® Chiller Operator Log

Water-Cooled CenTraVac® Chillers with Symbio Controller			
Tracer® AdaptiView™ Reports — Log Sheet	Log 1	Log 2	Log 3
Evaporator			
Active Chilled Water Setpoint			
Evaporator Entering Water Temperature			
Evaporator Leaving Water Temperature			
Evaporator Approach Temperature			
Evaporator Saturated Rfgt Temp			
Evaporator Refrigerant Pressure			
Evaporator Water Flow Status			
Approximate Evaporator Water Flow			
Evaporator Water Pump Override			
Evaporator Differential Water Pressure			
Condenser			
Active Hot Water Setpoint			
Condenser Entering Water Temperature			
Condenser Leaving Water Temperature			
Condenser Approach Temperature			
Condenser Saturated Rfgt Temp			
Condenser Refrigerant Pressure			
Condenser Water Flow Status			
Approximate Condenser Water Flow			
Condenser Water Pump Override			
Condenser Differential Water Pressure			
Differential Refrigerant Pressure			
Condenser Refrigerant Liquid Level			
Compressor			
Compressor Running Status			
Compressor Starts			
Compressor Running Time			
Oil Pump Discharge Pressure			
Oil Tank Pressure			
Oil Differential Pressure			
Oil Tank Temperature			
Oil Differential Pressure Switch			
IGV 1 Percent Open			
IGV 2 Percent Open			
Outboard Bearing Pad Temperature 1			
Outboard Bearing Pad Temperature 2			
Outboard Bearing Pad Temperature 3			
Motor			
Active Demand Limit Setpoint			
Average Motor Current % RLA			
AFD Percent Speed			
AFD Calculated Motor Voltage			
Chiller Load Command			
Starter Motor Current L1 % RLA			
Starter Motor Current L2 % RLA			
Starter Motor Current L3 % RLA			



Appendix E: CenTraVac® Chiller Operator Log

Water-Cooled CenTraVac® Chillers with Symbio Controller			
Tracer® AdaptiView™ Reports — Log Sheet	Log 1	Log 2	Log 3
Starter Motor Current L1			
Starter Motor Current L2			
Starter Motor Current L3			
Starter Input Voltage AB			
Starter Input Voltage BC			
Starter Input Voltage CA			
Average Motor Current			
AFD Motor Current U % RLA			
AFD Motor Current V % RLA			
AFD Motor Current W % RLA			
AFD Motor Current U			
AFD Motor Current V			
AFD Motor Current W			
AFD Motor Voltage UV			
AFD Motor Voltage VW			
AFD Motor Voltage WU			
Unit Power Consumption			
Chiller Power Demand			
Starter Motor Power Factor			
Motor Winding Temperature 1			
Motor Winding Temperature 2			
Motor Winding Temperature 3			
Motor Temperature			
MTC Switch			
Motor Coolant Temperature			
Speed Command			
Motor Speed			
Motor Frequency or Frequency Command			
AFD Transistor Temperature			
AFD Heatsink Temperature			
Purge			
Daily Pumpout 24 Hours			
Average Daily Pumpout 7 Days			
Daily Pumpout Limit			
Chiller On 7 Days			
Pumpout Chiller On 7 Days			
Pumpout Chiller Off 7 Days			
Time Until Next Purge Run			
Purge Rfgt Compressor Suction Temp			
Purge Liquid Temperature			
Pumpout Life			
Purge Carbon Tank Temperature			
Date:			
Technician:			
Owner:			



Notes

Trane - by Trane Technologies (NYSE: TT), a global innovator - creates comfortable, energy efficient indoor environments for commercial and residential applications. For more information, please visit trane.com or tranetechnologies.com.

Trane has a policy of continuous product and product data improvements and reserves the right to change design and specifications without notice. We are committed to using environmentally conscious print practices.

CVHE-SVX005E-EN 11 Apr 2026
Supersedes CVHE-SVX005D-EN (December 2024)

©2026 Trane