

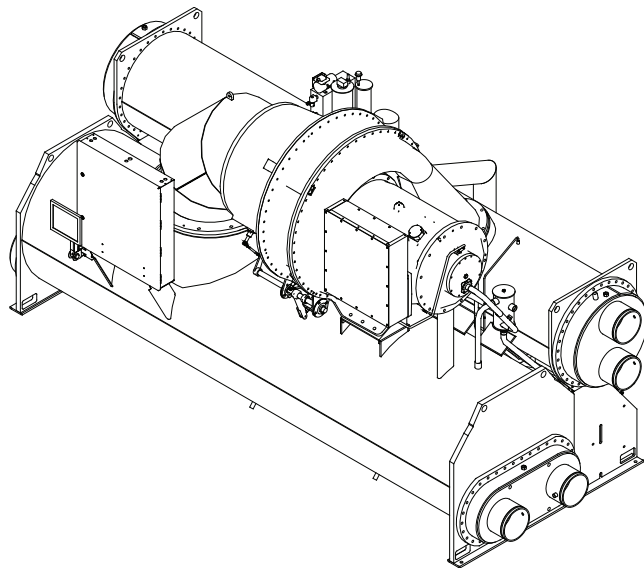

Installation, Operation, and Maintenance **R-514A Low-Pressure Refrigerant Handling Guidelines**

Conservation and Safe Handling of R-514A Refrigerant in Trane® Chillers for Service Technicians

CDHF
CDHG
CVHE
CVHF
CVHG
CVHL
CVHM



X39641295004

▲ SAFETY WARNING

Only qualified personnel should install and service the equipment. The installation, starting up, and servicing of heating, ventilating, and air-conditioning equipment can be hazardous and requires specific knowledge and training. Improperly installed, adjusted or altered equipment by an unqualified person could result in death or serious injury. When working on the equipment, observe all precautions in the literature and on the tags, stickers, and labels that are attached to the equipment.



Introduction

Read this manual thoroughly before operating or servicing this unit.

Warnings, Cautions, and Notices

Safety advisories appear throughout this manual as required. Your personal safety and the proper operation of this machine depend upon the strict observance of these precautions.

The three types of advisories are defined as follows:

⚠ WARNING Indicates a potentially hazardous situation which, if not avoided, could result in death or serious injury.

⚠ CAUTION Indicates a potentially hazardous situation which, if not avoided, could result in minor or moderate injury. It could also be used to alert against unsafe practices.

NOTICE Indicates a situation that could result in equipment or property-damage only accidents.

Important Environmental Concerns

Scientific research has shown that certain man-made chemicals can affect the earth's naturally occurring stratospheric ozone layer when released to the atmosphere. In particular, several of the identified chemicals that may affect the ozone layer are refrigerants that contain Chlorine, Fluorine and Carbon (CFCs) and those containing Hydrogen, Chlorine, Fluorine and Carbon (HCFCs). Not all refrigerants containing these compounds have the same potential impact to the environment. Trane advocates the responsible handling of all refrigerants-including industry replacements for CFCs and HCFCs such as saturated or unsaturated HFCs and HCFCs.

Important Responsible Refrigerant Practices

Trane believes that responsible refrigerant practices are important to the environment, our customers, and the air conditioning industry. All technicians who handle refrigerants must be certified according to local rules. For the USA, the Federal Clean Air Act (Section 608) sets forth the requirements for handling, reclaiming, recovering and recycling of certain refrigerants and the equipment that is used in these service procedures. In addition, some states or municipalities may have additional requirements that must also be adhered to for responsible management of refrigerants. Know the applicable laws and follow them.

⚠ WARNING

Proper Field Wiring and Grounding Required!

Failure to follow code could result in death or serious injury.

All field wiring **MUST** be performed by qualified personnel. Improperly installed and grounded field wiring poses **FIRE** and **ELECTROCUTION** hazards. To avoid these hazards, you **MUST** follow requirements for field wiring installation and grounding as described in **NEC** and your local/state/national electrical codes.

⚠ WARNING

Personal Protective Equipment (PPE) Required!

Failure to wear proper PPE for the job being undertaken could result in death or serious injury. Technicians, in order to protect themselves from potential electrical, mechanical, and chemical hazards, **MUST** follow precautions in this manual and on the tags, stickers, and labels, as well as the instructions below:

- Before installing/servicing this unit, technicians **MUST** put on all PPE required for the work being undertaken (Examples; cut resistant gloves/sleeves, butyl gloves, safety glasses, hard hat/bump cap, fall protection, electrical PPE and arc flash clothing). **ALWAYS** refer to appropriate Safety Data Sheets (SDS) and OSHA guidelines for proper PPE.
- When working with or around hazardous chemicals, **ALWAYS** refer to the appropriate SDS and OSHA/GHS (Global Harmonized System of Classification and Labelling of Chemicals) guidelines for information on allowable personal exposure levels, proper respiratory protection and handling instructions.
- If there is a risk of energized electrical contact, arc, or flash, technicians **MUST** put on all PPE in accordance with OSHA, NFPA 70E, or other country-specific requirements for arc flash protection, **PRIOR** to servicing the unit. **NEVER PERFORM ANY SWITCHING, DISCONNECTING, OR VOLTAGE TESTING WITHOUT PROPER ELECTRICAL PPE AND ARC FLASH CLOTHING. ENSURE ELECTRICAL METERS AND EQUIPMENT ARE PROPERLY RATED FOR INTENDED VOLTAGE.**

⚠ WARNING**Follow EHS Policies!**

Failure to follow instructions below could result in death or serious injury.

- All Trane personnel must follow the company's Environmental, Health and Safety (EHS) policies when performing work such as hot work, electrical, fall protection, lockout/tagout, refrigerant handling, etc. Where local regulations are more stringent than these policies, those regulations supersede these policies.
- Non-Trane personnel should always follow local regulations.

⚠ WARNING**Refrigerant May Be Under Positive Pressure!**

Failure to follow instructions below could result in an explosion which could result in death or serious injury or equipment damage.

System contains refrigerant and may be under positive pressure; system may also contain oil. Recover refrigerant to relieve pressure before opening the system. See unit nameplate for refrigerant type. Do not use non-approved refrigerants, refrigerant substitutes, or non-approved refrigerant additives.

NOTICE**Equipment Damage!**

Mixing refrigerants or oils could result in equipment damage including bearing damage, introduction of acids into the chiller, or continuous purge pump-out in high-head/high ambient applications.

CenTraVac™ chillers are manufactured with different refrigerant/oil systems: 1) chillers using R-123 refrigerant and OIL00022 compressor oil, and 2) chillers using R-514A refrigerant and various Trane POE-based compressor oils.

Always verify proper refrigerant and oil for your chiller. Do NOT mix refrigerants and oils.

Important: This Installation, Operation, and Maintenance manual is for CVHE/F/G and CDHF/G chillers operating with R-514A refrigerant and OIL00379/380 compressor oil, and for CVHM chillers operating with OIL00381/OIL00382 compressor oil. Verify proper refrigerant and compressor oil for your chiller before proceeding.

Copyright

This document and the information in it are the property of Trane, and may not be used or reproduced in whole or in part without written permission. Trane reserves the right to revise this publication at any time, and to make changes to its content without obligation to notify any person of such revision or change.

Trademarks

All trademarks referenced in this document are the trademarks of their respective owners.

Revision History

- Updated R-514A refrigerant information in Job Requirements chapter.
- Running edits.

Reference Materials

- Chemours R-514A SDS
- Chemours "R-514A Properties, Uses, Storage, and Handling"
- BSR/ASHRAE Standard 15
- ANSI/ASHRAE Standard 34
- Code of Federal Regulations, Title 29, Part 1910



Table of Contents

Jobsite Requirements	5	Container Return Shipping	
General Information	5	Procedure	9
Read Appropriate Service Literature.....	5	Acceptable Empty Containers.....	9
Inspect Equipment Room.....	5	Acceptable Full Containers	9
Purge Venting	6	Credits for Full Product Returns	9
Checking the Machine for Integrity	7	Credits for Returned Empty	
Check Refrigerant Detector	7	Cylinders.....	10
Self-Contained Breathing Apparatus	7	Credits for Returned Defective	
Review Jobsite Records	7	Containers	10
New Units	7	Palletizing Containers Properly	10
Existing Units	7	Empty Cylinder Returns	10
		Defective Containers	10
		Preparing the Bill-of-Lading	10



Jobsite Requirements

General Information

⚠ WARNING

Refrigerant May Be Under Positive Pressure!

Failure to follow instructions below could result in an explosion which could result in death or serious injury or equipment damage.

System contains refrigerant and may be under positive pressure; system may also contain oil. Recover refrigerant to relieve pressure before opening the system. See unit nameplate for refrigerant type. Do not use non-approved refrigerants, refrigerant substitutes, or non-approved refrigerant additives.

NOTICE

Equipment Damage!

Mixing refrigerants or oils could result in equipment damage including bearing damage, introduction of acids into the chiller, or continuous purge pump-out in high-head/high ambient applications.

CenTraVac™ chillers are manufactured with different refrigerant/oil systems: 1) chillers using R-123 refrigerant and OIL00022 compressor oil, and 2) chillers using R-514A refrigerant and various Trane POE-based compressor oils. Always verify proper refrigerant and oil for your chiller. Do NOT mix refrigerants and oils.

Important: This Installation, Operation, and Maintenance manual is for CVHE/F/G and CDHF/G chillers operating with R-514A refrigerant and OIL00379/380 compressor oil, and for CVHM chillers operating with OIL00381/OIL00382 compressor oil. Verify proper refrigerant and compressor oil for your chiller before proceeding.

Regulations regarding waste handling are constantly changing. To ensure that your office and personnel are in compliance with the latest federal, state, and local regulations, contact your local waste management office for the proper procedures on handling, disposal, transporting and storage of oil, oil filters, and filter drier cores.

Although this guide was prepared for the safe handling of low-pressure refrigerants, i.e. R-514A, many of the same procedures may be applied for the safe handling of all refrigerants. Because these are updated guidelines, procedures for the service technician's conservation and safe handling of low-pressure refrigerants in Trane® chillers will differ from guidelines previously published.

Many items listed in this guide are suggested by specific reference and vendor information; see "Reference Materials," p. 3. At appropriate times throughout this guide, you will be referred back to this introduction with regard to regulations for the handling and disposal of waste materials.

Read Appropriate Service Literature

Refer to the service literature that shipped with your unit prior to servicing equipment. Additional information is available in the following document:

- *Refrigerant Safety in HVAC Applications* (TECH-PRA010-EN)

Inspect Equipment Room

Comply with the local safety codes that are applicable to your geographical area; refer to ASHRAE Standard 15 if local codes are not yet updated to accommodate the alternative refrigerant. Trane recommends that all equipment rooms meet ASHRAE Standard 15 requirements as a minimum. All commonly used low-pressure and high-pressure refrigerants are included in ASHRAE Standard 15.

In addition to standard code practices of the past, ASHRAE Standard 15 defines four additional key areas that should be followed for all refrigerants. A Personal Breathing Apparatus is no longer required by ASHRAE Standard 15, but may be required by local codes.

Refrigerant Detector—Sensors that are capable of monitoring the appropriate refrigerant concentration levels are required for all refrigerants.

Mechanical Ventilation—Use mechanical ventilation sized as directed in ASHRAE Standard 15 (typically not required for penthouse and lean-to applications). Check ASHRAE Standard 15 and local codes for details.

Alarms—Use an alarm activated at, or below, the TLV-TWA or equivalent.

Note: For R-514A there is no TLV-TWA, so the AEL is used as the equivalent; refer to the following table.

The alarm shall annunciate visual and audible alarms inside the refrigerating machinery room and outside each entrance to the refrigerating machinery room.

The alarms required in this section shall be of the manual reset type with the reset located inside the refrigerating machinery room.

Alarms set at other levels (such as IDLH) and automatic reset alarms are permitted in addition to those required by this section. The meaning of each alarm shall be clearly marked with signs near the annunciators.

Jobsite Requirements

Table 1. Allowable personal exposure levels for R-514A

Exposure Level	Source	R-514A (ppm)
OEL ^(a)	ASHRAE Standard 34, derived from the established WEEL ^(b) values for R-1336mzz(Z) and R-1130(E)	320

^(a) OEL = Occupational Exposure Limit. An upper limit on the acceptable concentration of a hazardous substance in workplace air for a particular material or class of materials. It is typically set by competent national authorities and enforced by legislation to protect occupational safety and health.

^(b) WEEL = Workplace Environmental Exposure Level. Level to which it is believed a worker can be exposed day after day for a working lifetime without adverse effects.

Purge Venting

Pipe the relief device and purge outdoors using refrigerant-compatible materials, and refer to the *Installation, Operation, and Maintenance* manual that shipped with your unit. A drip-leg with a shutoff valve should be provided on the vent piping. Check for liquid accumulation in the drip leg at regular maintenance intervals.

Figure 1. Rupture disc relief piping arrangement

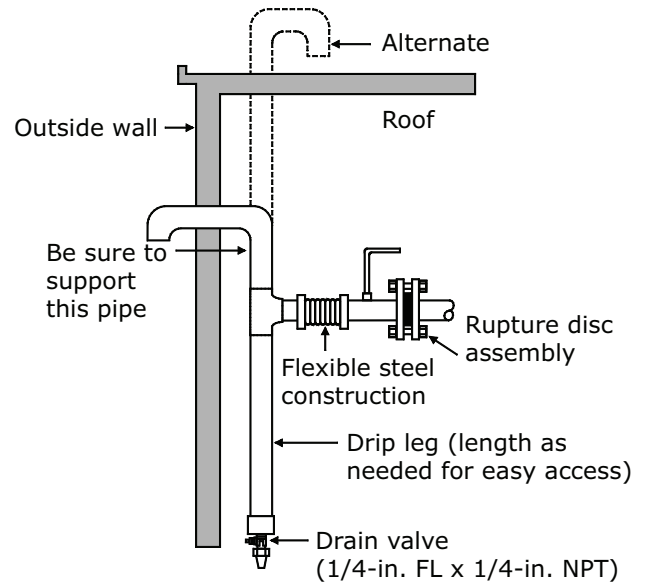



Checking the Machine for Integrity

⚠ WARNING

Refrigerant Vapor Hazard!

Refrigerant vapors may collect and concentrate in confined spaces or low lying areas which will result in the displacement of air. This poses a potential health risk due to suffocation. Failure to follow proper handling guidelines could result in death or serious injury.

Refer to the appropriate MSDS or SDS sheets and OSHA/GHS guidelines for information referring to allowable personal exposure levels and handling guidelines.

Check Refrigerant Detector

Check the refrigerant detector for current levels in the equipment room. If high concentrations exceeding the applicable exposure limit are indicated, activate ventilation per ASHRAE Standard 15 to ensure an adequate supply of fresh air.

Self-Contained Breathing Apparatus

⚠ WARNING

Self-Contained Breathing Apparatus!

Improper use of a self-contained breathing apparatus could result in death or serious injury from suffocation.

Obtain medical qualification and follow training guidelines before using Self-Contained Breathing Apparatus (SCBA) or other respiratory protection device.

Check for the availability of self-contained breathing apparatus (SCBA) and any other personal safety equipment. Check local codes, as requirements vary for providing SCBAs in the equipment room. Make sure devices are calibrated, tested, and properly maintained.

Review Jobsite Records

Use jobsite records to identify:

1. Recent monitoring levels of refrigerant in the equipment room.
2. Monitoring equipment calibration intervals versus the manufacturer's recommendations (generally monthly).
3. Operational history of the chiller.

New Units

Important: New units that have been factory run-tested contain residual R-514A; vent discharge outdoors.

Contact your local Trane Service representative to perform the following checks:

- Check to make sure there is a positive pressure holding charge.

Note: New units ship with a 5 psig (34.5 kPa) dry nitrogen holding charge at nominal 72°F (22.2°C).

- If the machine is flat, perform positive pressure leak test.
- For field-assembled units, a leak test is mandatory.
- Begin the evacuation process. Perform standing leak rise test before charging the unit.
- If leak testing is required, use dry nitrogen to 8 psig (55.2 kPa) and check with soap and water, or other solutions. If a trace gas becomes absolutely necessary to identify a leak, a small quantity of a trace gas and dry nitrogen should be used. Refrigerant and air mixture should NOT be used due to potentially combustible nature.

Existing Units

Contact your local Trane Service representative to perform the following checks:

- Check operating logs and purge history for indications of excessive leaks. Small and large leaks can be identified by comparing the purge run minutes per day to the following figure.
- If leaks are noted, perform leak-testing procedure before adding any refrigerant to the chiller.

Figure 2. Purge operation under typical and leak conditions

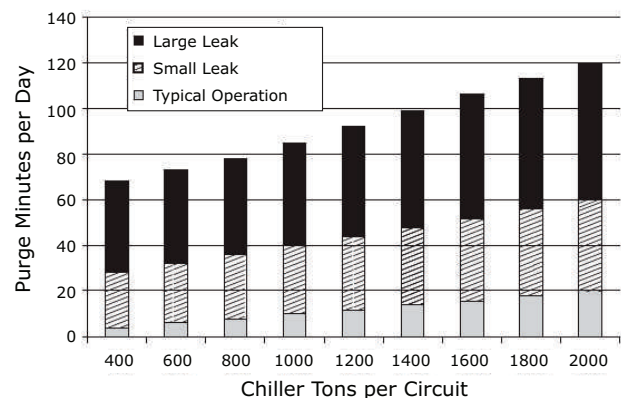



Checking the Machine for Integrity

The preceding figure was created using the average annual refrigerant leakage rate to be calculated based

on the daily purge pump out time and the unit refrigerant charge.



Container Return Shipping Procedure

Note: After commissioning is complete, it is the installer's responsibility to transport empty refrigerant containers to an easily accessible point of loading to facilitate container return or recycling.

Use the following procedure for returning empty or defective containers, or extra (not recovered) product.

1. For returning extra product, contact your Chemours Sales or Customer Service Representative for approval and disposition. All product returns are subject to Chemours approval and will be based on the ability of Chemours to resell the product.
2. **Complete the Return Authorization (RA) form.** Returns must be done through the website. This process simplifies the return process. You can find the online form (Bill of Lading) via the following link:

Complete and submit the form using the buttons located in the lower right-hand side of the form.

Note: For questions, contact Chemours Customer Service, 7:30 a.m. to 4:00 p.m. Eastern time, at (800) 441-9605 extension 1, or email: CustomerService.fcreturns@chemours.com

3. **Empty Cylinder Returns:** Palletize vertically for a maximum of nine (9) SUVA® 123 cylinders per pallet. Band the cylinders together and then band them to the pallet.
4. **Defective (Leakers/Damaged) Containers and Other Return Product:** Consolidate and ship with return containers. Tag with defective/damage/or full cylinder labels.
5. **Chemours Transportation (TONA)** will contact the person listed on the submitted Return Authorization (RA) form to arrange shipment. Chemours TONA will inform you of the RA number, carrier, and Chemours return location. Normally,

this is the site that originally shipped product to you. Write the RA number you are given on the RA form and Bill of Lading for the carrier.

6. When returning defective or full containers, identify each container with a "Returned for Inspection" tag. This tag must be filled out completely and must cross-reference the RA number and customer purchase order number.
7. Ship to Chemours. Provide the carrier with a Bill of Lading and attach the RA form (packing list) to the shipment.

Acceptable Empty Containers

Any Chemours R-514A returnable container will be accepted.

Note: The DOT requires valves to be protected for shipping on all cylinders, including returned empties. Contact your customer service representative for details.

If a container shows visible damage, Chemours will scrap it out as it cannot be reused. Examples of damage for which Chemours will scrap cylinders include:

- Use of a flame on cylinders, as evidenced by burn marks through the paint.
- Dents of length of 4 in. (101.6 mm) or greater.
- Gouges in the metal to a depth of 3/8 in. (9.5 mm) or greater.
- Severe rusting (more than 50 percent of the cylinder).

Important: Do NOT apply a flame to cylinders in order to facilitate faster unloading.

Acceptable Full Containers

Full containers will be accepted if the following criteria are met:

- The container is full and the protective shrink-wrap is intact on the valve.
- The container does not show visible damage.

If the shrink-wrap is removed, return the product through the recovered refrigerant program. Contact your Chemours sales or customer service representative for details.

Credits for Full Product Returns

- Credit amount will be based on the customer's last purchase price of product.
- A 30 percent restocking fee will be assessed based on the current list price of product unless Chemours overshipped.



Container Return Shipping Procedure

Credits for Returned Empty Cylinders

Empty cylinders returned to Chemours will be accepted for credit if:

1. The container is less than two years old. To determine the date of a cylinder, look at the small sticker. As an example, a sticker that shows 120L8A or 120/8A is decoded as:

120 = 120th day of the year
8 = Year, 1998
L or A = Filler's I.D.

2. The container does not show visible damage.
3. The container is lightweight or empty, and the protective shrink-wrap is intact on the valve.

If the shrink-wrap is removed but the customer has determined that the container is defective, the defect will be verified by a Chemours site inspection; refer to next section.

Credits for Returned Defective Containers

- Credit amount will be based on the current list price of product.
- If container is full and no defect is found, a 30 percent handling fee will be assessed based on the current list price of product.
- All defective containers reported and returned by customer will be inspected to determine appropriate disposition as shown in the following table.
- For situations where defect cannot be readily identified upon receipt, credit will be issued up front; if defect is later found, offsetting debit will be applied.

Container Contents	Shrink-Wrap Intact		Defect Confirmed (a)		Credit Charges(b)
	Partially Empty	Full	Yes	No	
X		X		X	Full
X		X		X	Full
X		X			No credit
	X		X	X	Full
	X		X		Full less 30% handling fee

(a) Common defects include broken valves, leaks at valve stems, rupture disc failure, and empty or lightweight containers with shrink-wrap intact.

(b) Individual cases will be reviewed with Sales/Marketing for final disposition.

Palletizing Containers Properly

1. Verify that the cylinders (valves, plugs, reliefs, etc.) are secure and not leaking.
2. Identify all containers and pallets with RA tags that include RA number and customer purchase order number.

3. Return freight collect. Chemours TONA will tell you which Chemours location to ship to. Normally, this is the site that originally shipped the cylinders to you.
4. All shipments must be properly blocked and braced.

Empty Cylinder Returns

Empty cylinders should be palletized vertically on a standard 4-way pallet (preferably on the same pallet(s) as received) and secured for shipment using adequate banding materials. Bands should be at two or three locations vertically (6–12 in. [152.4–304.8 mm] below the top shoulder, 6–12 in. [152.4–304.8 mm] above the base, and the center) to ensure the load does not separate during transport.

Defective Containers

Consolidate **defective containers** with other returned product for shipping.

Tag defective containers with the tag included at the end of “ ”.

Empty containers should be returned on the same pallet(s) as received and properly secured to the pallet to provide a safe return to Chemours. Use banding to secure cylinders to pallet(s).

Options for banding material include:

1. Steel banding that uses the 3/4-in. (19.1-mm) wide by 0.023-in. (0.6-mm) thick banding with 3/4-in. (19.1-mm) clips. Kits that have the bander, crimper, seals, and banding are about \$275.00 each.
2. Poly strapping. A kit costs about \$90.00 including the tensioner, cutter, buckles, and 1,000 ft (304.8 m) plastic banding.

Steel banding and poly strapping kits can be ordered through any local supply house for shipping materials.

Preparing the Bill-of-Lading

Chemours provides a bill-of-lading (BOL) form for return shipments on their website. All items on this form should be filled out by the shipper except those specifically indicated to be filled out by the carrier. The BOL form must contain the following information:

- Proper shipping name
- Name of carrier
- Date
- Company name and address of shipper
- Signature of shipping company's representative
- Shipping destination
- Number and types of containers
- Freight prepaid or collect

Container Return Shipping Procedure

- Gross product weight, in pounds (includes the weight of the containers, except for tank trucks)
- DOT “Nonflammable Gas” placards are not required for shipments of R-514A in any container size since this material is not regulated by the DOT.
- Driver’s signature

Trane - by Trane Technologies (NYSE: TT), a global innovator - creates comfortable, energy efficient indoor environments for commercial and residential applications. For more information, please visit trane.com or tranetechnologies.com.

Trane has a policy of continuous product and product data improvements and reserves the right to change design and specifications without notice. We are committed to using environmentally conscious print practices.

CTV-SVX008D-EN 01 Mar 2022
Supersedes CTV-SVX008C-EN (August 2020)

©2022 Trane