



Installation, Operation, and Maintenance **Performance Climate Changer™** **Air Handlers**

Outdoor Unit Installation Details
Models CSAA and PSCA

▲ SAFETY WARNING

Only qualified personnel should install and service the equipment. The installation, starting up, and servicing of heating, ventilating, and air-conditioning equipment can be hazardous and requires specific knowledge and training. Improperly installed, adjusted or altered equipment by an unqualified person could result in death or serious injury. When working on the equipment, observe all precautions in the literature and on the tags, stickers, and labels that are attached to the equipment.

March 2026

CLCH-SVX024A-EN

TRANE
TECHNOLOGIES™



Introduction

Read this manual thoroughly before operating or servicing this unit.

Warnings, Cautions, and Notices

Safety advisories appear throughout this manual as required. Your personal safety and the proper operation of this machine depend upon the strict observance of these precautions.

The three types of advisories are defined as follows:



Indicates a potentially hazardous situation which, if not avoided, could result in death or serious injury.



Indicates a potentially hazardous situation which, if not avoided, could result in minor or moderate injury. It could also be used to alert against unsafe practices.



Indicates a situation that could result in equipment or property-damage only accidents.

Important Environmental Concerns

Scientific research has shown that certain man-made chemicals can affect the earth's naturally occurring stratospheric ozone layer when released to the atmosphere. In particular, several of the identified chemicals that may affect the ozone layer are refrigerants that contain Chlorine, Fluorine and Carbon (CFCs) and those containing Hydrogen, Chlorine, Fluorine and Carbon (HCFCs). Not all refrigerants containing these compounds have the same potential impact to the environment. Trane advocates the responsible handling of all refrigerants.

Important Responsible Refrigerant Practices

Trane believes that responsible refrigerant practices are important to the environment, our customers, and the air conditioning industry. All technicians who handle refrigerants must be certified according to local rules. For the USA, the Federal Clean Air Act (Section 608) sets forth the requirements for handling, reclaiming, recovering and recycling of certain refrigerants and the equipment that is used in these service procedures. In addition, some states or municipalities may have additional requirements that must also be adhered to for responsible management of refrigerants. Know the applicable laws and follow them.

⚠ WARNING

Proper Field Wiring and Grounding Required!

Failure to follow code could result in death or serious injury.

All field wiring **MUST** be performed by qualified personnel. Improperly installed and grounded field wiring poses **FIRE** and **ELECTROCUTION** hazards. To avoid these hazards, you **MUST** follow requirements for field wiring installation and grounding as described in **NEC** and your local/state/national electrical codes.

⚠ WARNING

Personal Protective Equipment (PPE) Required!

Failure to wear proper PPE for the job being undertaken could result in death or serious injury.

Technicians, in order to protect themselves from potential electrical, mechanical, and chemical hazards, **MUST** follow precautions in this manual and on the tags, stickers, and labels, as well as the instructions below:

- **Before installing/servicing this unit, technicians MUST put on all PPE required for the work being undertaken (Examples; cut resistant gloves/sleeves, butyl gloves, safety glasses, hard hat/bump cap, fall protection, electrical PPE and arc flash clothing). ALWAYS refer to appropriate Safety Data Sheets (SDS) and OSHA guidelines for proper PPE.**
- **When working with or around hazardous chemicals, ALWAYS refer to the appropriate SDS and OSHA/GHS (Global Harmonized System of Classification and Labelling of Chemicals) guidelines for information on allowable personal exposure levels, proper respiratory protection and handling instructions.**
- **If there is a risk of energized electrical contact, arc, or flash, technicians MUST put on all PPE in accordance with OSHA, NFPA 70E, or other country-specific requirements for arc flash protection, PRIOR to servicing the unit. NEVER PERFORM ANY SWITCHING, DISCONNECTING, OR VOLTAGE TESTING WITHOUT PROPER ELECTRICAL PPE AND ARC FLASH CLOTHING. ENSURE ELECTRICAL METERS AND EQUIPMENT ARE PROPERLY RATED FOR INTENDED VOLTAGE.**

⚠ WARNING**Follow EHS Policies!**

Failure to follow instructions below could result in death or serious injury.

- All Trane personnel must follow the company's Environmental, Health and Safety (EHS) policies when performing work such as hot work, electrical, fall protection, lockout/tagout, refrigerant handling, etc. Where local regulations are more stringent than these policies, those regulations supersede these policies.
- Non-Trane personnel should always follow local regulations.

⚠ WARNING**Cancer and Reproductive Harm!**

This product can expose you to chemicals including lead and bisphenol A (BPA), which are known to the State of California to cause cancer and birth defects or other reproductive harm. For more information go to www.P65Warnings.ca.gov.

Copyright

This document and the information in it are the property of Trane, and may not be used or reproduced in whole or in part without written permission. Trane reserves the right to revise this publication at any time, and to make changes to its content without obligation to notify any person of such revision or change.

Trademarks

All trademarks referenced in this document are the trademarks of their respective owners.



Table of Contents

General Information	5	Seam Cap Installation - Supporting Article	
Pre-Installation	6	Details Link	10
Installation	7	Roof Panel Joint Variations	11
Outdoor Section-to-Section Assembly	7	Stacked Unit Assembly	15
Wedge Block Installation	9	Stacked Flashing	17
Crate Parts	10	Pipe Cabinet Installation	23
		Hood Installation	29



General Information

Reference Documents:

- *Performance Climate Changer™ Air Handlers Model CSAA Sizes 3 to 120 Indoor and Outdoor Applications Installation, Operation, and Maintenance Manual (CLCH-SVX016*-EN)*
- *Performance Climate Changer™ Air Handlers Model PSCA Installation, Operation, and Maintenance Manual (CLCH-SVX018*-EN)*

The Installation, Operation, and Maintenance (IOM) manuals for outdoor CSAA and PSCA product lines encompass a wide range of installation scenarios. This document provides additional installation guidance to reduce complexity, simplify the process, and highlight essential details for clear and streamlined instructions.



Pre-Installation

Follow all lifting guidelines and practices outlined in the equipment IOM.

Installation

Outdoor Section-to-Section Assembly

Air handlers are shipped with all necessary assembly hardware, including butyl tape. This hardware is usually packaged in a clear plastic envelope or yellow bag(s) located in the fan section, access section, or mixing box of the unit. Since assembly materials may be distributed across multiple sections, inspect all sections thoroughly to verify all components are available before contacting your Trane sales representative about any missing items. A thorough inspection will facilitate smoother installation process.

Figure 1. IOM



Figure 2. Kits



Sections are joined by applying butyl tape to one of the mating surfaces and then bolting the sections together.

To assemble the unit:

1. Locate the mounting hardware and butyl material inside the unit.
2. Remove and discard all shipping supports and crating on the face of the section for proper fit and sealing.

3. Remove any shipping bolts located on the mounting surfaces of the sections.
4. Connect high and low voltage wiring according to the equipment IOM section-to-section quick connects detail.

Important: *Wiring connections must be made before pulling the sections together, especially when access will be limited after, such as back-to-back coil modules with no access door. It is impossible to make the connection once the sections are pulled together without disassembling a wall panel, which creates the opportunity for panel damage and leakage issues.*

Figure 3. Horizontal section-to-section low voltage quick connects

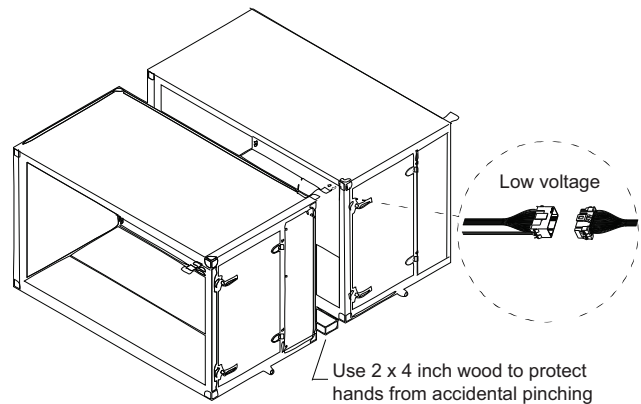


Figure 4. Section-to-section installation

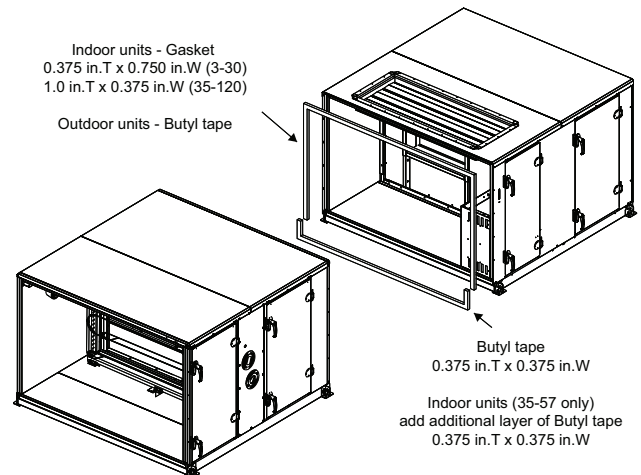
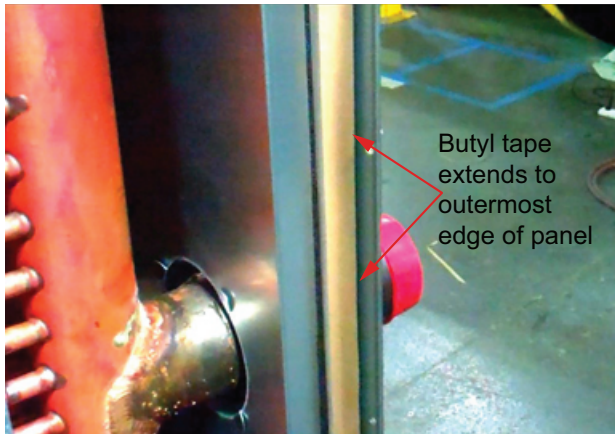
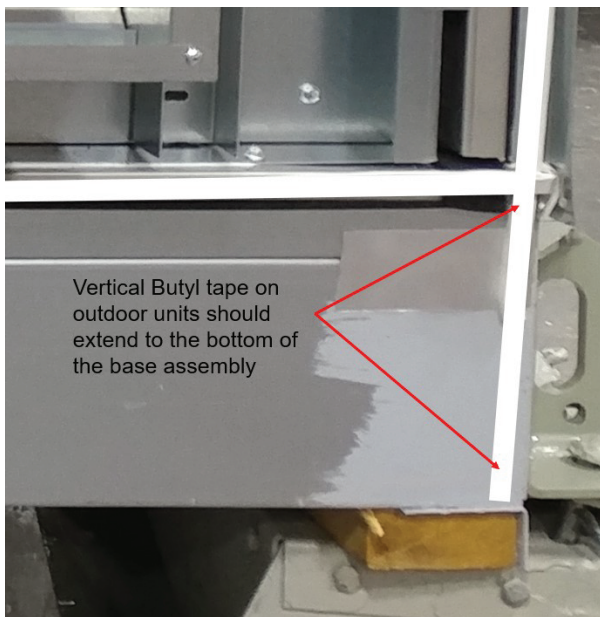


Figure 5. Install Butyl tape to outermost edge of panel

Figure 6. Install butyl tape on outdoor bases

Figure 7. Shipping split lift


5. Bolt the unit base frames together using connection hardware listed below:

- Unit sizes 3 to 30: 5/16-inch bolts
- Unit sizes 35 to 120: 1/2-inch threaded rod

Note: Read the unit placement and assembly - shipping gussets excerpt before the alignment process begins.

Figure 8. Shipping gusset

Figure 9. Shipping split seam – top view


Table 1. Outdoor section-to-section assembly hardware (3 to 120 unit sizes)

Description	Specification
Threaded bolt and rod	0.500-13 X 10.5 in Threaded Rod
Washer	0.656 ID X 0.312 OD Washer
Nut	0.50 -13 Nut Hex Flange

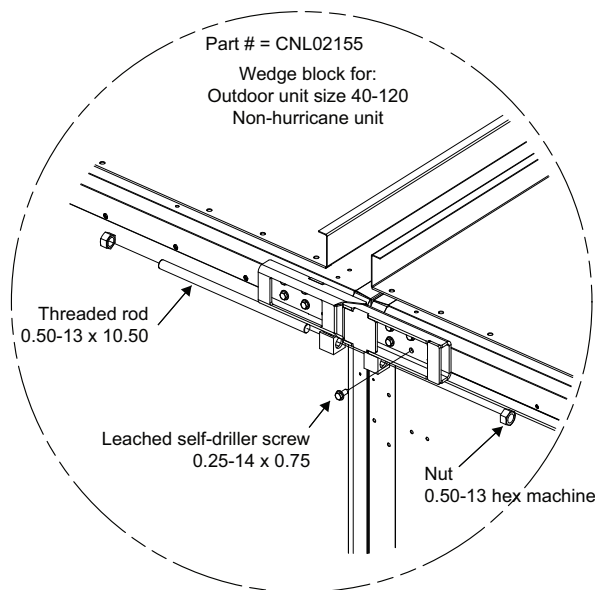
Wedge Block Installation

Note: Updated wedge block design will be available in early 2026. See *Wedge Block (Information Only) Service Alert* for temporary alignment methods to be used until the new design is released.

The wedge block kit is designed for unit sizes 40 to 120. The kit includes a set of offset wedge brackets attached to the four top corners of all sizes of two adjacent shipping splits.

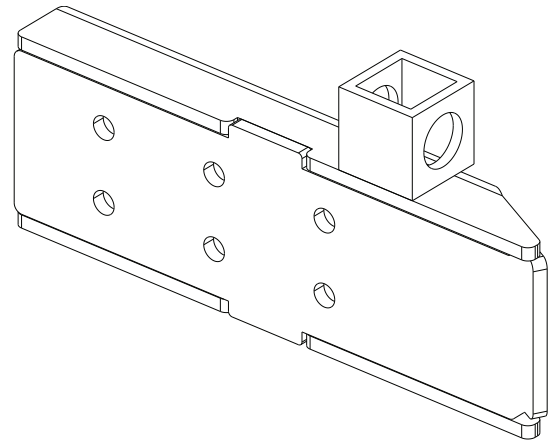
- The kits are used for temporary alignment only during the joining process.
- The kit will be used for all additional field joints, as needed.
- The wedge block will interfere with proper sealing of exterior seams, so it must be removed.
- Kit can be discarded after use, or retained for future installations, if performed often.

Figure 10. Shipping split assembly



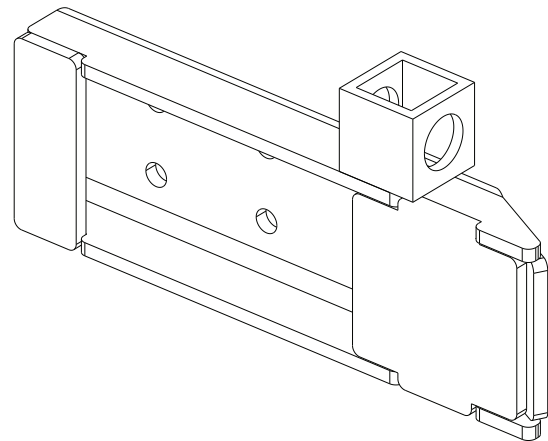
Note: Overhang removed for clarity.

Figure 11. LH wedge block assembly



ISO VIEW

Figure 12. RH wedge block assembly



ISO VIEW

For reference only, the following graphics show the old right hand wedge block assembly design.

Figure 13. Right hand wedge block assembly – old design



- For unit sizes 66 to 120 only: Bolt through the wedge blocks using a 1/2-threaded rod. Alternate between tightening on the lifting lug bolts and wedge block bolts until the shipping section comes together.
- For unit sizes 3 to 30: Use straps and Come Along to compress the gasketing and pull the sections together along the height of the unit if the wedge block kit is not provided.

Note: Wedge blocks are used to assemble shipping splits together for unit sizes 35 to 120. Only one set of wedge blocks is shipped with each unit. Once the shipping split has been assembled, remove the wedge blocks and use for the next shipping split.

Crate Parts

The crated parts include seam caps, roof strips, c-channels, support brackets, stacked flashing, wide roof strips, etc. depending on the unit size and configuration.

Figure 14. Ship with crate



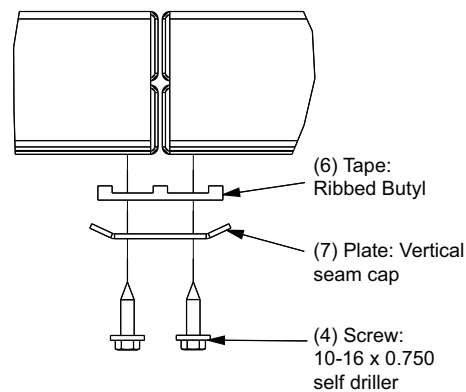
Seam Cap Installation - Supporting Article Details Link

For unit integrity and performance, the seams between sections must be covered with the provided seam cap. Before applying the seam caps, apply the factory-supplied butyl tape continuously over the top and side seams of the air handler.

Important: The tape must be a single, uninterrupted layer without any tears or breaks to maintain a proper seal.

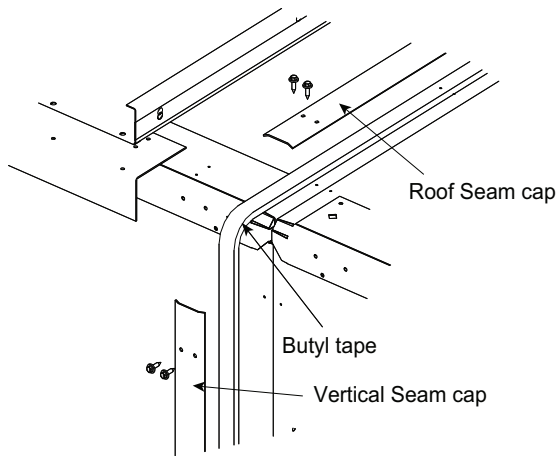
Corners require special attention, particularly where the roof meets the wall. Do NOT end the tape at these corners, as they will not be covered by the seam cap. The tape is the primary barrier against rain infiltration, making its proper installation essential. For a correct application of the seam cap and butyl tape, see [Figure 15, p. 10](#).

Figure 15. Seam cap installation – shipping split seams



Note: Overhang and roof removed for clarity.

Figure 16. Roof seam cap installation



Roof Panel Joint Variations

Unit Size 35 (DSEQ L or Earlier Legacy), and Size 40 thru 120

See Wide Roof Strip Details on CSAA/PSCA AHUs for more information.

The wide roof strip provides an essential connection to adjacent shipping split outer roof panels.

This connection forms a watertight seal along the roofline, crucial for rainwater management and leak prevention.

- Unit size 40: Only one wide roof strip is required for the entire roof width.
- Unit sizes 50 to 120: Two wide roof strips are required to adequately cover the full width of the outer roof joint.

Figure 17. Left end view

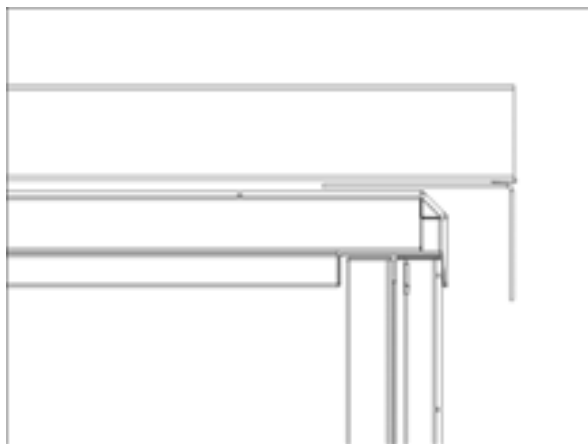
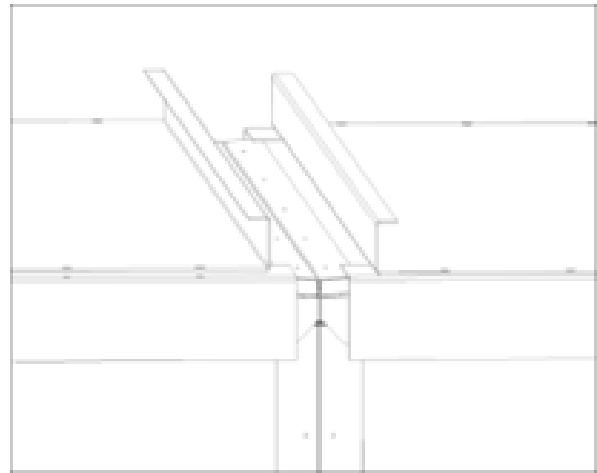


Figure 18. Corner detail



1. Cover the edges between adjacent overhangs along the vertical plane with field-supplied foil tape to prevent birds and insects from entering the enclosed roof area. This helps maintain a clean, pest-free environment and prevents potential complications.

Figure 19. Foil tape

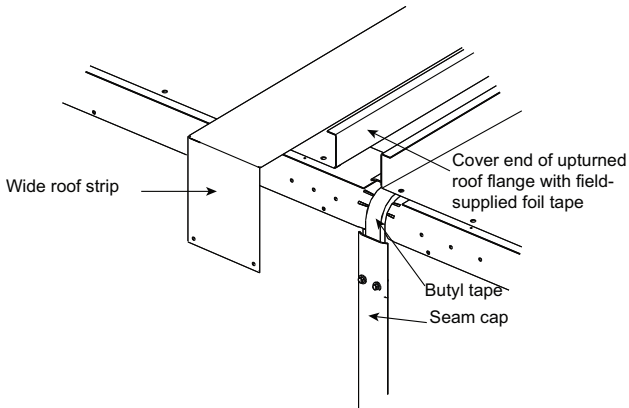


2. Carefully slide the wide roof strip along the flange of the outer roof panels.

Important: This crucial initial step sets the foundation for the entire installation.

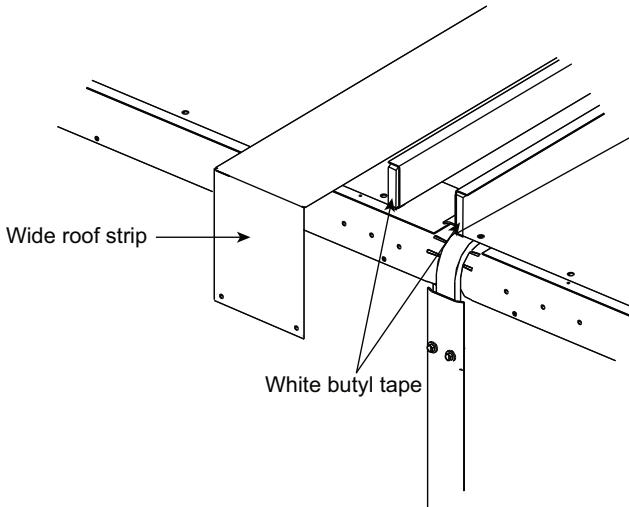
3. After the strip has been positioned accurately, manually form it down to verify it fits snugly against the overhang surface. This hand-formation plays a significant role in achieving a secure and effective seal.

Important: Alignment issues with the outer roof flanges must be addressed before continuing the installation. Proper alignment is crucial to prevent future complications. Misaligned shipping splits can compromise the weatherization of the wide roof strips, leading to leaks or damage. Correct alignment is essential for roof installation integrity and long-term performance.

Figure 20. Section-to-section seam cap installation


Note: Overhang not shown for clarity.

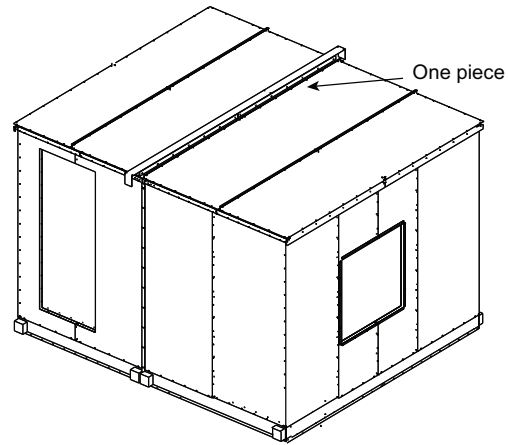
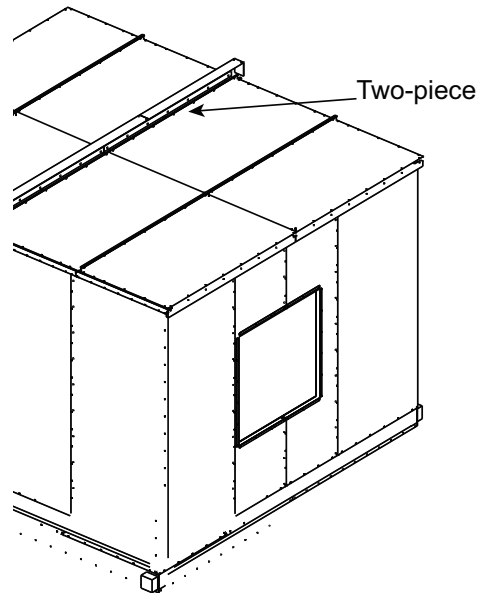
4. For additional, critical water management, apply two strips of white butyl tape along the vertical exposed edges of the outer roof panels.

Figure 21. Additional layer butyl tape installation


Note: Overhang not shown for clarity.

5. To enhance the roof's structural integrity and weather resistance, secure the wide roof strip by driving the provided screws into the roof overhang. With the wide roof strip attached, the butyl tape installed creates a water dam effect, preventing rainwater from seeping below the roof.

Important: This step is crucial for protecting the interior space from water damage.

Figure 22. Single roof

Figure 23. Double roof


6. For unit sizes 50 or larger, a two-piece wide roof strip is required. Apply a bead of caulk (Manus Bond/Sika Brand, or equivalent) to seal the seam where the two wide strips meet along the roof.

Figure 24. Two-piece wide roof strip caulk


Important: DO NOT install the wide roof strip with the screw holes located in the middle of the roof. This is a leak path that is counter to design intent and rain testing standards performed during engineering validation.

Figure 25. Do not wide roof strip



Vertical Seam on Outer Roof Panels

Seal all vertical roof seams on the roof with a bead of caulk.

- The factory vertical seams in the outer roof panels should be sealed.
- Verify the entire roof is sealed to prevent water infiltration.

Figure 26. Vertical gap caulk – split roof panels

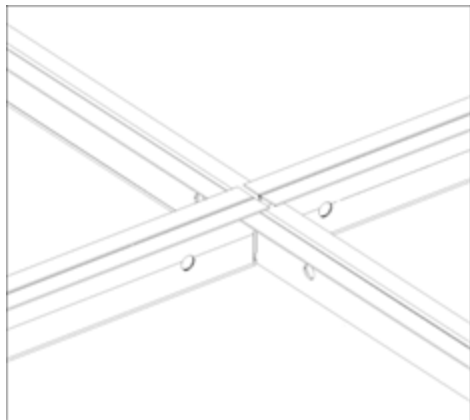


Figure 27. Vertical gap caulk

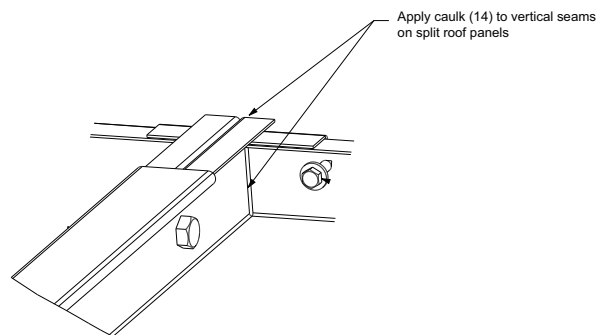


Figure 28. Vertical seam caulk missing

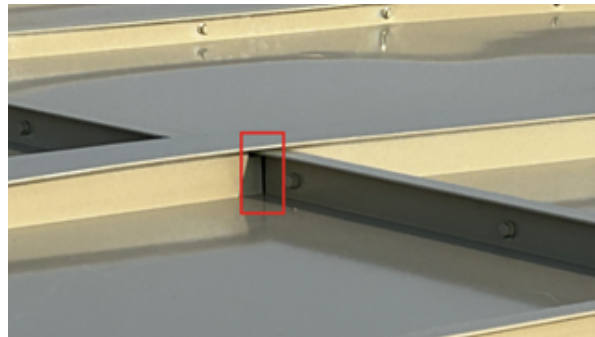


Figure 29. Vertical seam close-up



Unit Size CSAA 3 to 35 PSCA IW 27.5-96 inch

See C-Channel Roof Details on CSAA/PSCA AHUs for more information.

The new roof design is based on the UCCA outdoor roof and incorporates a section-to-section joint solution to accommodate CSAA's multiple shipping splits. A ship-with C-Channel (PTAF perpendicular to air flow) design is used to interlock adjacent shipping splits and uses brackets with gaskets to seal the gutter system. The integral sloped outer roof panels on each shipping split permits the gutter to direct water away from the roof. A key improvement over earlier designs is the integrated overhang on the outer roof panel, which reduces the number of parts and simplifies installation.

Figure 30. New roof

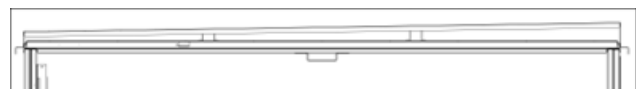
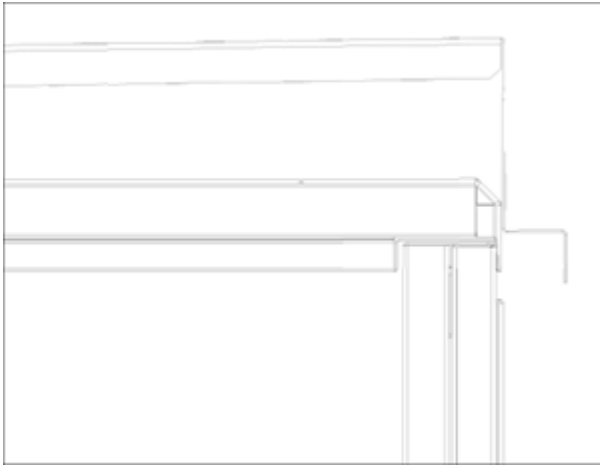
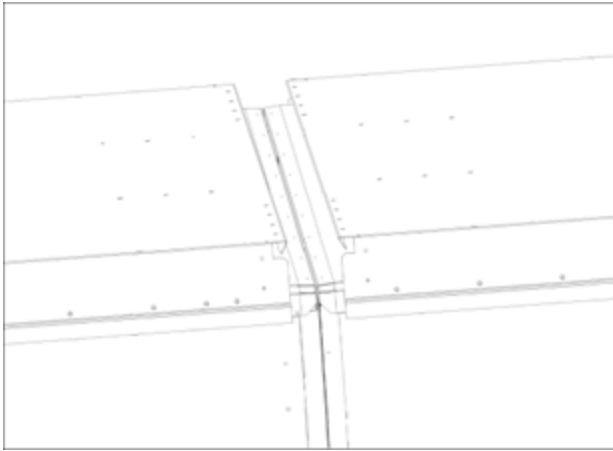
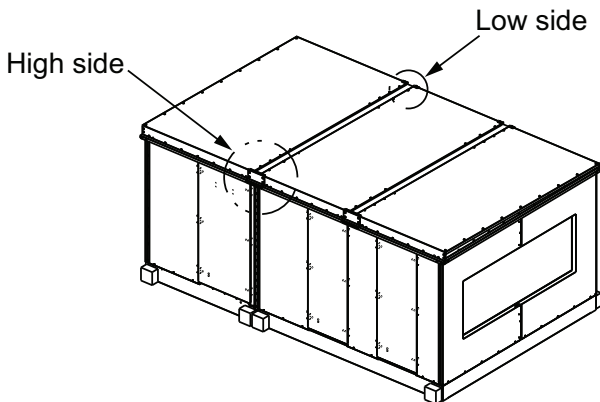


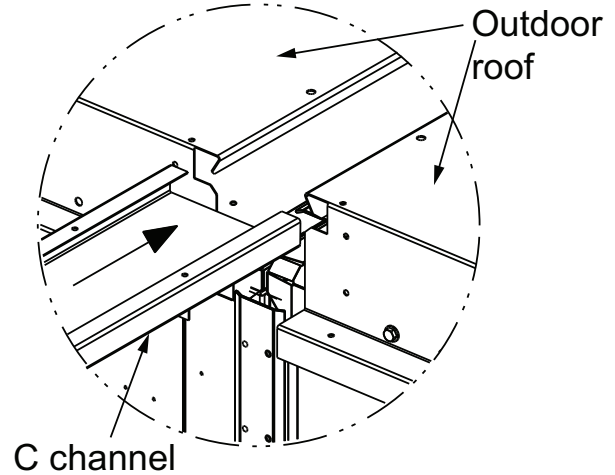
Figure 31. New roof cross

Figure 32. New roof joint


C-Channel Installation

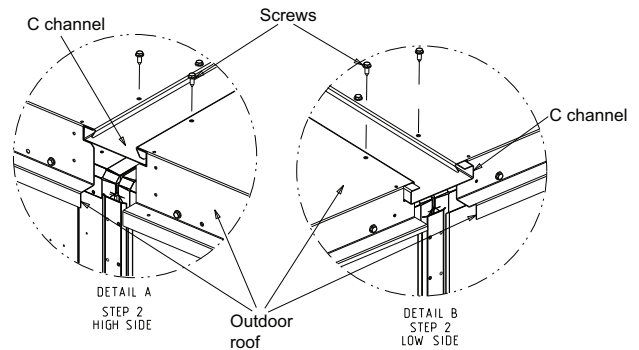
1. Verify the shipping splits are pulled together and aligned properly. Correct any roof elevation issues or plum wall panel problems before proceeding.

Figure 33. C-channel installation – high side and low side


2. Slide the c-channel from the side of the outer roof panel at the shipping split.
3. Verify the c-channel is flush with the outer roof edge on the higher pitched side (High Side) of the outer roof, based on the horizontal plane.

Figure 34. Slide c-channel


4. Secure the c-channel to the shipping split outer roofs using the provided screws (HPU 0.250-14 x .75 leached self-driller with plastisol).

Figure 35. C-channel installation – secure with screws


Support Bracket Installation

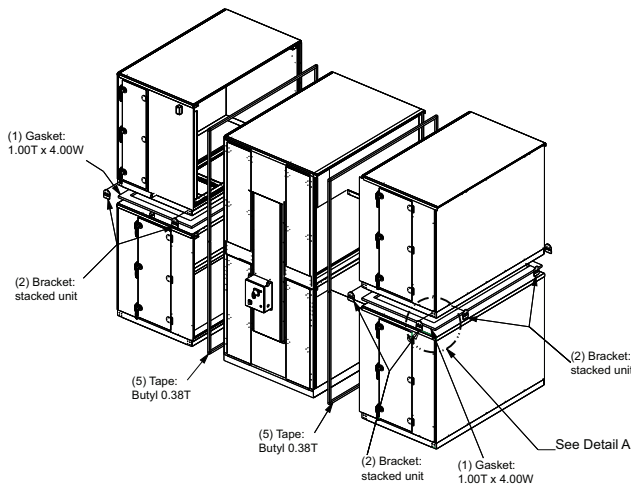
1. Verify the appropriate support bracket gasket is used on the correct side for effective water management and longevity of c-channel performance.
2. High Side Assembly:
 - a. Assemble the support bracket without notch and corresponding gasket for the High Side on the flush end of the c-channel and outer roof panels.
 - b. Attach the assembly using the provided screws (.250-14 x .75 leached self-driller with plastisol).
3. Low Side Assembly:

- a. Assemble the support bracket with notch and corresponding gasket for the Low Side on the overlapping outer roof panel end of the c-channel.
- b. Attach the assembly using the provided screws (.250-14 x .75 leached self-driller with plastisol).

Stacked Unit Assembly

Trane Select Assist (TSA) is used to select stacked units in the following ranges: CSAA 03 to 50 and PSCA 27.5 to 96 inches.

Figure 36. Stacked unit assembly



1. Follow the Installation and Operation Manual (IOM) instructions to correctly prepare and install the second level section a top the first level section.
2. Verify the first level is fully installed, including the energy wheel (EW), Cool, Dry, Quiet (CDQ) wheel, and Air-to-Air (ATA) sections, before lifting any second level sections into place. Do NOT proceed with the upper section installation until 3. the first level assembly is complete.
3. For configurations with a single or shared air path between sections:
 - a. Apply a 1-inch thick, 4-inch wide gasket on the roof of the lower section where the top level base rail contacts it.
 - b. Verify the gasket is adequately compressed to establish a solid air barrier.
4. Carefully lift the upper section according to the mechanical layout specified in the as-built submittals.

Important: *Install white butyl tape according to standard installation practices before lifting sections into place.*
5. Position the upper section on top of the lower section (s), confirming proper alignment and secure positioning.
6. If there is an adjacent shipping split on the second level with lifting lugs, use the provided threaded rods to pull

the sections together tightly at the lifting lugs to verify a snug fit.

7. For nominal unit sizes 35 to 50, use the wedge block kit. To prevent damage to the paint finish, use straps or clamps with a wood cleat to protect painted surfaces while aligning and pulling the top of the section together.
8. Seal the sections with 1.5-inch wide gray butyl and seam caps.
9. Remove the lifting lugs on the upper-level section(s). Retain the lifting lug bolts and screws for subsequent installation steps.

Figure 37. Stacked unit assembly – gasket installation

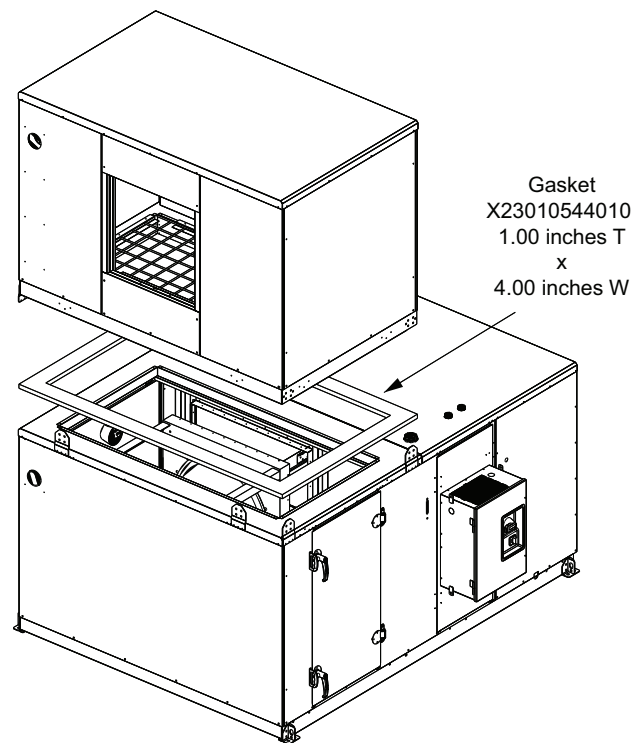


Table 2. Parts list for gasket installation

Item	Description
1	Gasket: 1.00T x 4.00 W
2	Bracket: Stacked unit
3	Screw: 0.313–18 x 0.875 sheet metal
4	Screw: 10–16 x 0.750 self driller
5	Tape: Butyl 0.38T

Figure 38. Stacking bracket installation

Remove lugs from upper baserail prior to installing stacked unit bracket

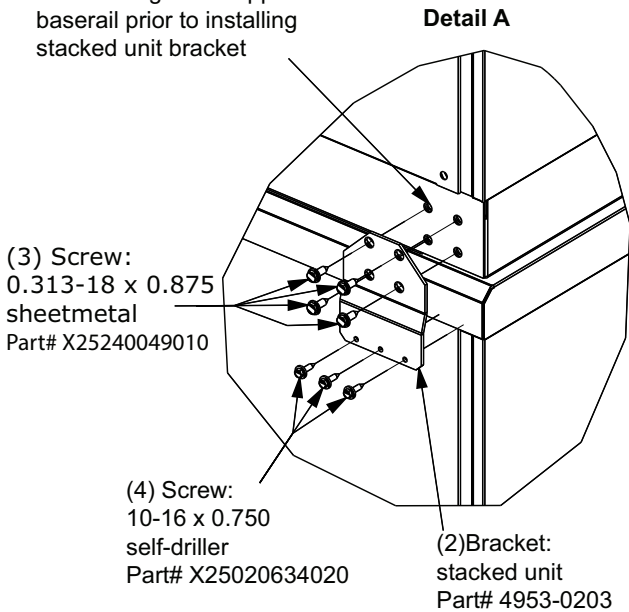


Figure 39. Stacking bracket installed



10. Attach the stacking brackets provided with the ship kits at the locations of the lifting lugs. Use factory mounting hardware and any additional screws necessary to secure the stacking brackets.

Notes:

- The stacking brackets, powder-coated in black, are designed to align with the baserail of the upper section and the roofline of the lower section.
- Additional stacking brackets are required at both the front and back for full-length units, or at either the front or back for units less than full length on the upper level.

Figure 40. Vertical seam cap installation

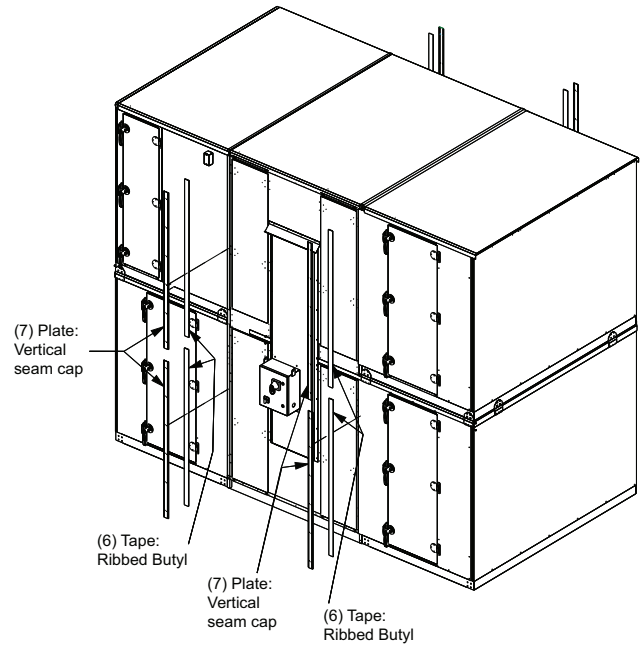


Table 3. Parts list for vertical seam cap installation

Item	Description
6	Tape: Ribbed Butyl
7	Plate: Vertical seam cap

11. Install vertical seam caps as follows:

- Install 1.5-inch gray butyl for the lower section seam cap. Verify installation is at least 1/2-inch below the wall panel of the second level.

Note: This step is necessary to provide adequate space for later installation of stacked flashing and butyl. The gray butyl beneath the seam caps is too thick to fit under stacked flashing and will not compress properly, causing the flashing to bow outward and look aesthetically dysfunctional. This misalignment can allow rainwater to infiltrate unsealed joints.

- Verify the seam cap on the lower level extends at least one inch beyond the bottom of the wall panel seam into the base rail. This extension is

critical for a secure and effective seal able to withstand environmental conditions.

Figure 41. Vertical seam cap installation – butyl tape installation

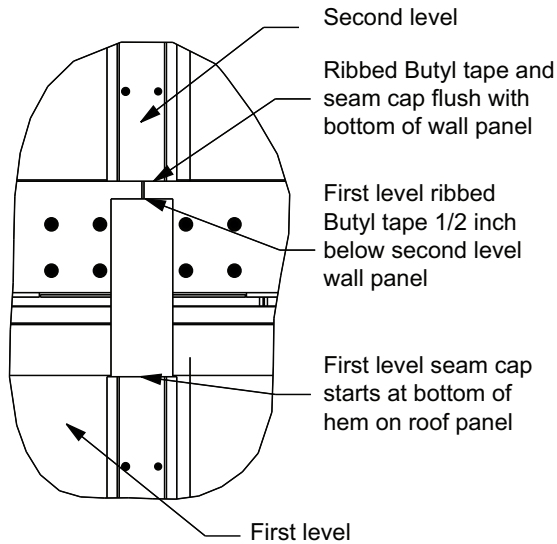
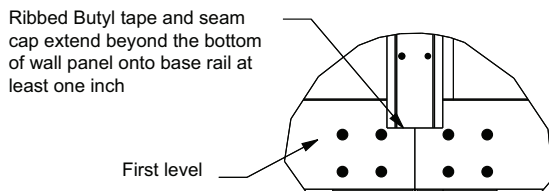


Figure 42. Vertical seam cap installation – extend beyond bottom of wall panel



Stacked Flashing

See Stacked Flashing details on CSAA/PSCA AHUs for more information.

Stacked flashing is standard on all outdoor CSAA/PSCA stacked units. The primary purpose is to seal the inherent gap between the lower section roof and upper section base rail.

Note: *Stacked Flashing (SFLASH_###) is a customized part number for each unit. No two units in an assembly, or even on a same order, will be identical.*

1. Apply gray butyl tape (.12 inch Tall x 1 inch Wide) to the perpendicular and direction-of-airflow flashing on all sections.
2. Secure the flashing to the baserail using the provided 10-16 x .750 self driller screws. The flashing hole patterns should align with the hole pattern along the base rail of the upper-level sections. Do not cut or screw the flashing into place. If issues are encountered, contact technical support for assistance.
3. For EW, CDQ, and ATA sections, preassemble end covers to the flashing with screws before installing to the unit.

Standard

Flashing Installation Location

Figure 43. Flashing installation details

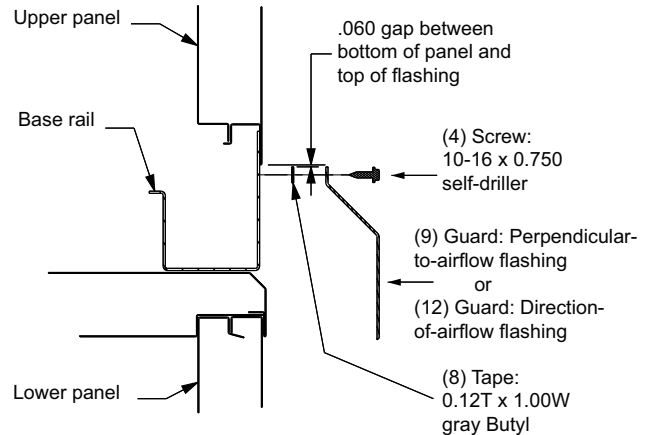


Table 4. Parts list for outdoor stacked units

Item	Description
8	Tape: 0.12T x 1.00W, gray Butyl
9	Guard: Perpendicular to airflow flashing
12	Guard: Direction to airflow flashing
13	Guard: Flashing seam cover
14	Adhesive/Sealant: Flex polyurethane

Corner Seams

Figure 44. Flashing for corner seams

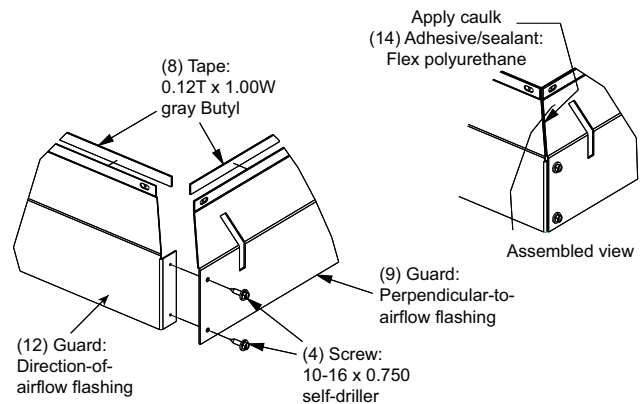
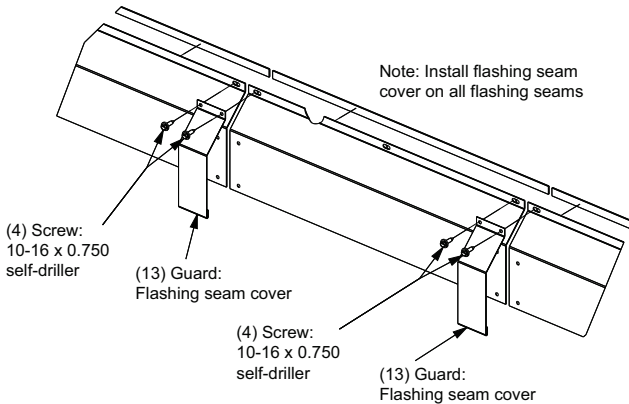


Figure 45. Stacked corner seam



Seam Cover

Figure 46. Flashing seam cover installation



End Guards

End guards are used on EW, CDQ, and ATA sections, and at various locations on less-than-full-length upper levels.

Figure 47. Flashing end cover

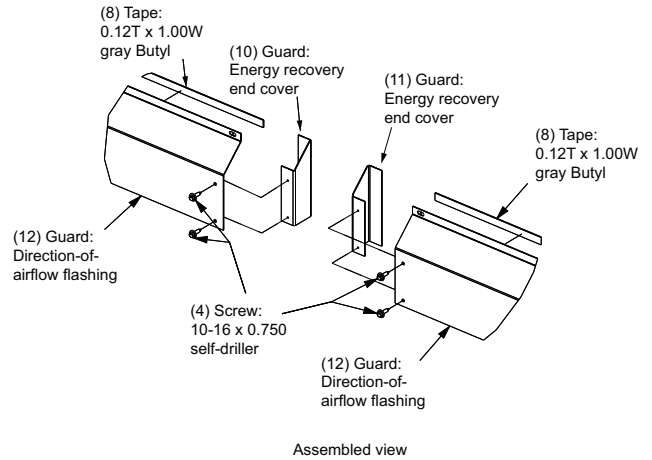
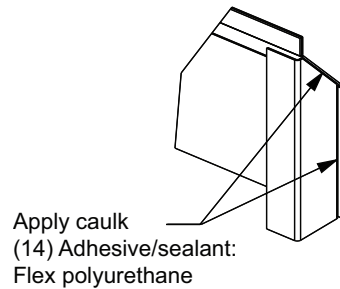


Figure 48. Flashing end cover – apply caulk



With Four Quadrant Doors

Figure 49. Side flashing installation without full height doors

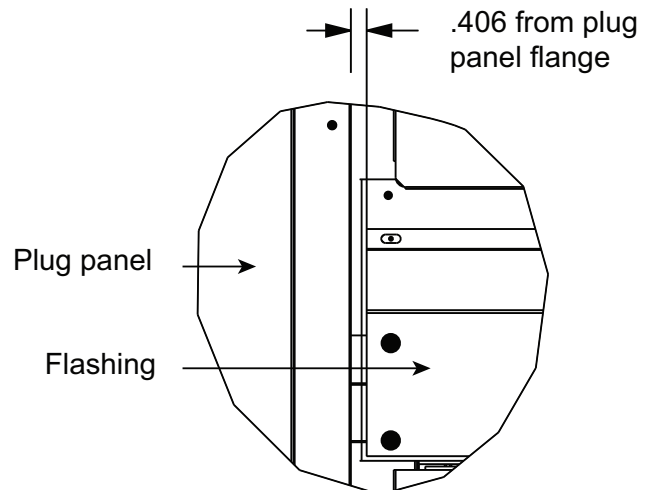


Figure 50. Side flashing installation

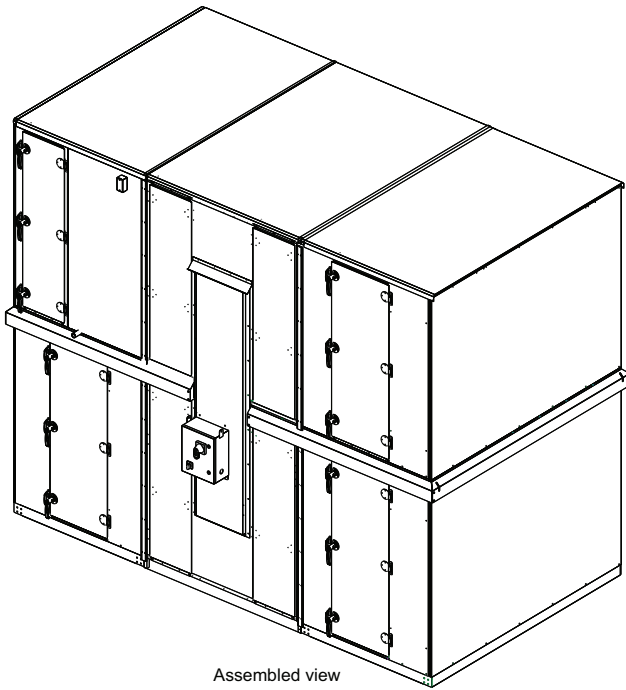


Figure 51. Stacked flashing four quadrant



With Two Full Height Doors

Figure 52. Side flashing installation with full height doors

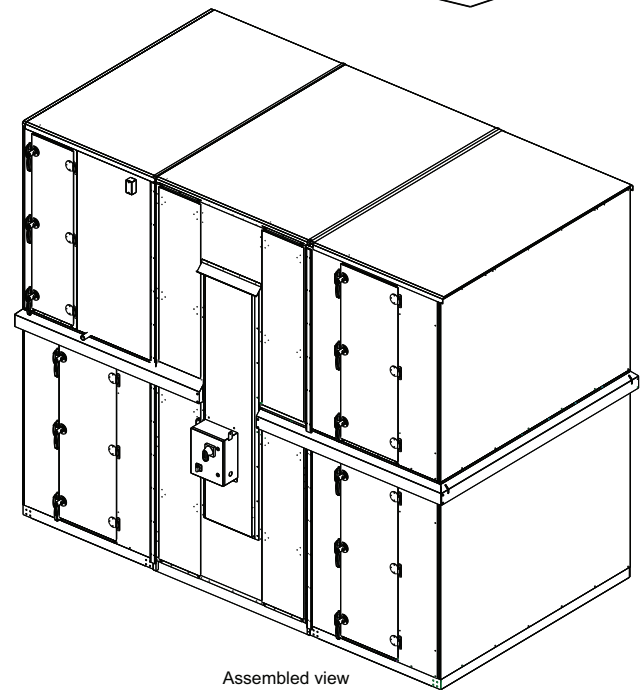
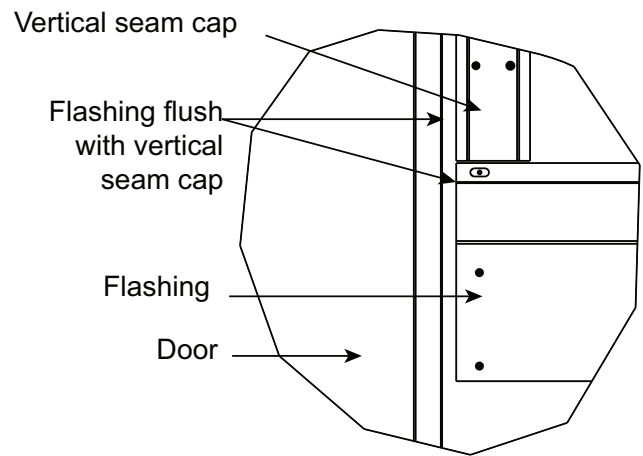


Figure 53. Full height door



Stacked Flashing Installation for Units with Upper Level Shorter Than the Lower Level

CSAA Size 40 and 50

These configurations are wide roof strip roof style, DSEQ L or earlier.

1. Verify/apply caulk to the lower-level roof at the form horizontal seam.
2. Bend the PTAF Stacked Flashing end tabs by hand or gently with channel locks/pliers.
 - a. Match the form on the DOAF stacked flashing mounted to the side of the unit.
 - b. Seal underneath with butyl tape where it mates.
3. For unit size 50 only:
 - a. Secure the PTAF to the base rail with 10-16 x .750 self-drilling screws.
 - b. Apply caulk to the exterior of the corner seal for a watertight seal.

Figure 54. Seal first level with caulk or Butyl tape

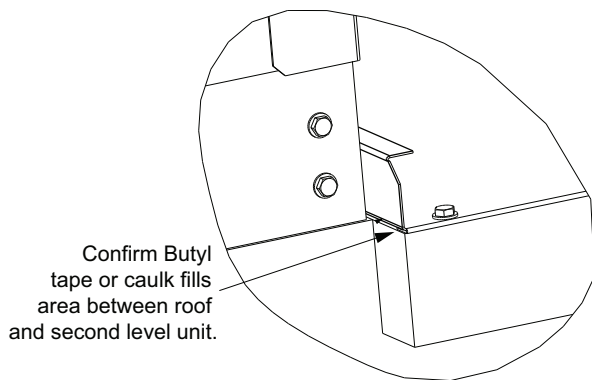


Figure 55. PTAF stacked flashing



Figure 56. Apply caulk to seal

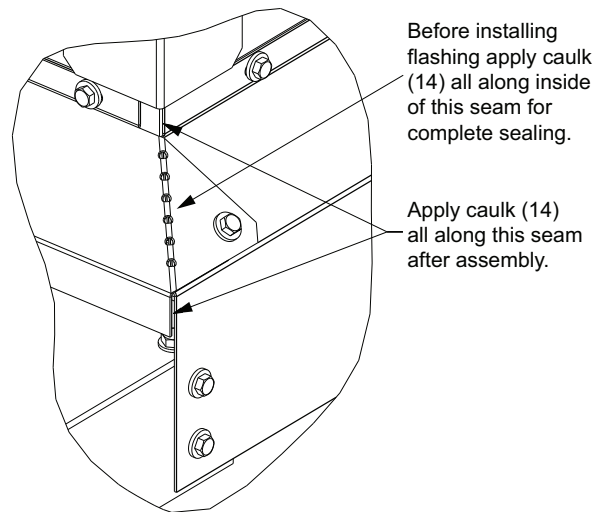
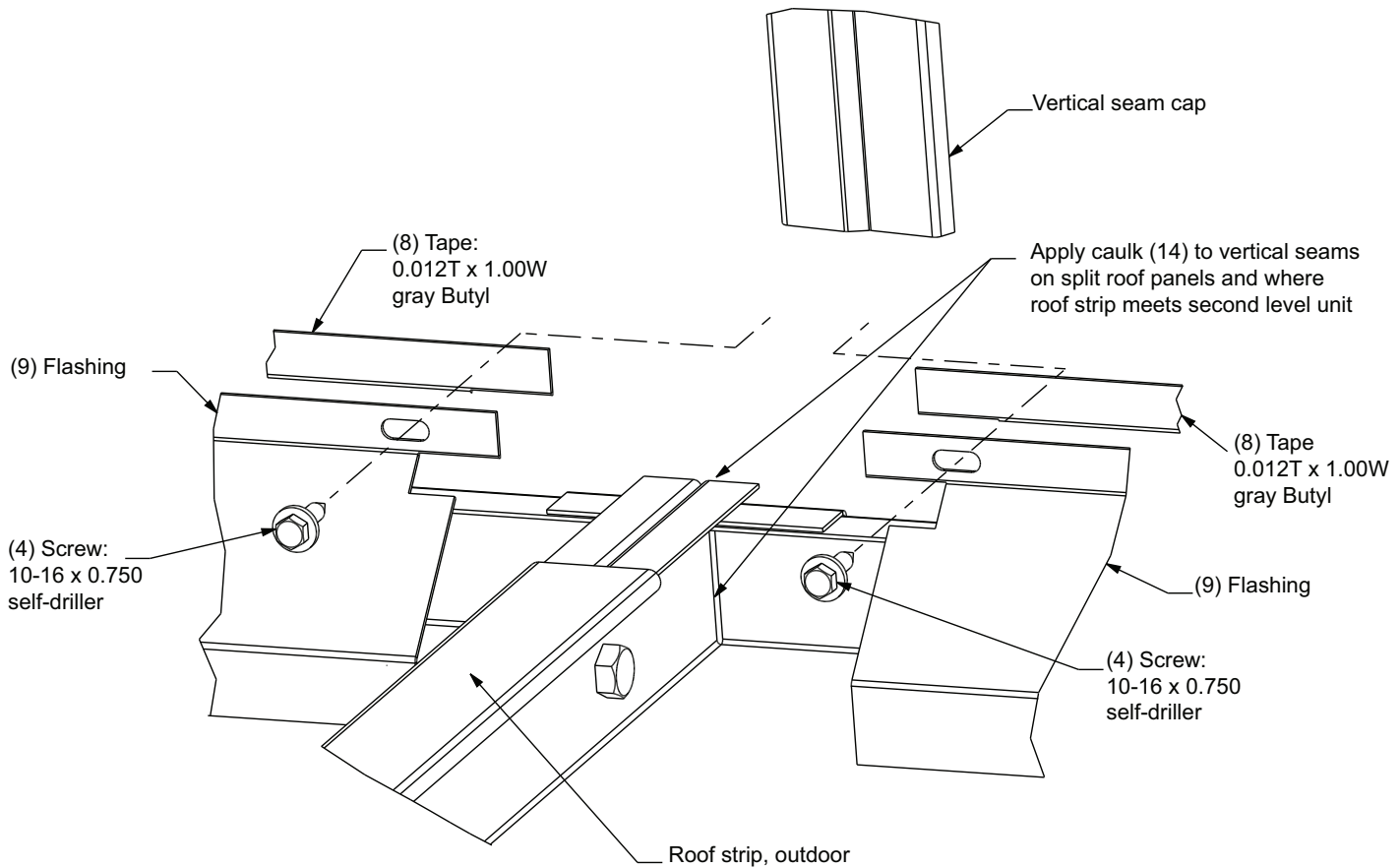


Figure 57. Caulk along seam



4. For unit size 50 with a two-piece roof panel, additional sealing is required in the middle where the first level roof section meets the second level baserail.
 - a. Apply caulk to the vertical flanges of the roof prior to installing the flashing.
 - b. Install the flashing.
 - c. Apply caulk to the joint after the flashing is installed.
 - d. Install the direction of airflow roof strip.
 - e. Smooth caulk into crevices to provide a watertight seal.

Figure 58. Flashing installation for perpendicular-to-airflow piece if second level of unit is shorter than first level



Important Stacked Flashing Installation Notes

- Side stacked flashing locating features:
 - Right side
 - Front and back pieces have two diamonds and a tab.
 - Intermediate right-side pieces (if present) have two diamonds. The length of the part matches the ship group length and mounting holes match the hole pattern on the unit.
 - Left side
 - Front and back pieces have one diamond
 - Intermediate right-side pieces (if present) have two diamonds. The length of the part matches the ship group length and mounting holes match the hole pattern on the unit.
- The stacked flashing runs full length on right/left sides of unit except on access side when an energy recovery section is present.
 - For energy recovery and air-to-air sections without full height doors, flashing will extend to removable plug panel.

- For energy recovery section with full height doors, flashing will be flush with edge of vertical seam caps.
- Flashing runs the full length on the front/back of the unit. Front/back flashing will not have any locating features and will always have a miter. (One piece has two miters, two pieces have one miter.)

CSAA Size 3 Thru 35 and PSCA IW 27.5 Thru 96 inch

Figure 59. Flashing installation part locations

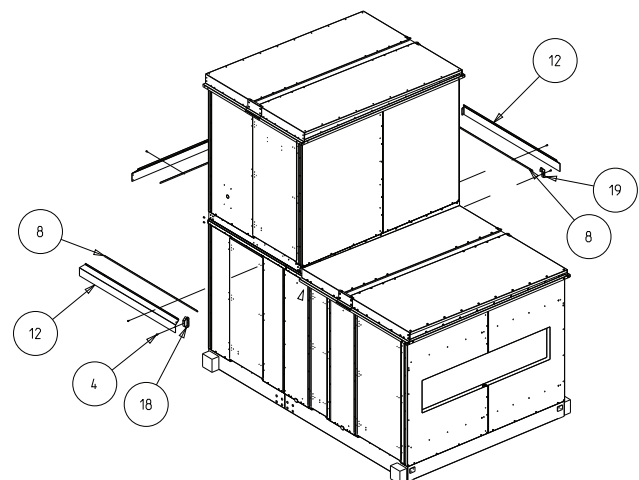


Table 5. Parts list

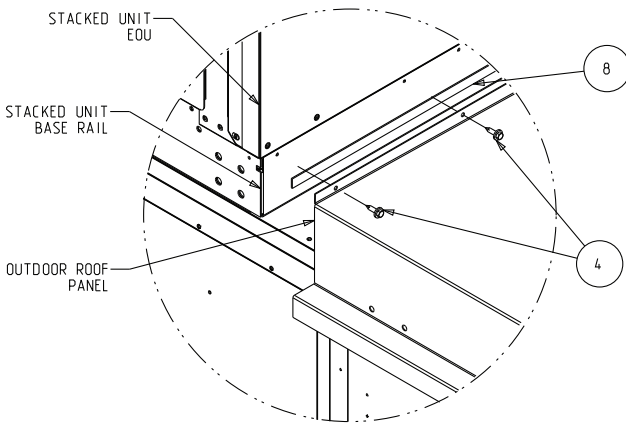
Item	Description
4	Screw: 10–16 x 0.750 self driller
8	Tape: 0.12T x 1.00W. gray butyl
12	Guard: Direction of airflow flashing
14	Adhesive/Sealant: Flex polyurethane
18	Skirt support bracket
19	Skirt support bracket

Stacked Outdoor Roof Panel Install

Note: High side – right hand (RH) drive side shown in the details below.

1. Assemble Skirt Support Bracket (Item 18) using Screw 10-16 x 0.750 self driller with outdoor roof panel at high side of the lower-level section.

Figure 60. Internal width 27.5 to 96 in. (des seq M or later), non-hurricane units

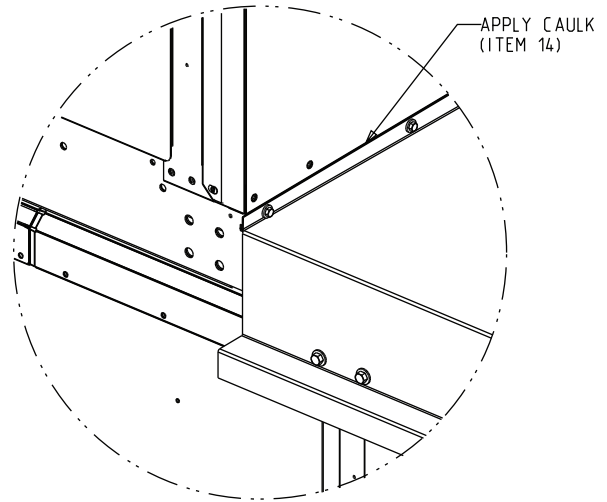


Note: Stacked flashing removed for clarity.

Figure 61. Stacked flashing to first level C-channel style roof

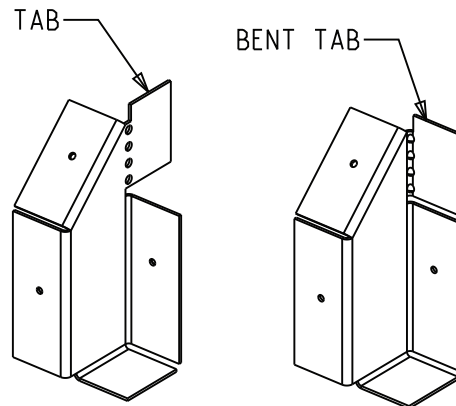


Figure 62. Internal width 27.5 to 96 in. (des seq M or later), non-hurricane units



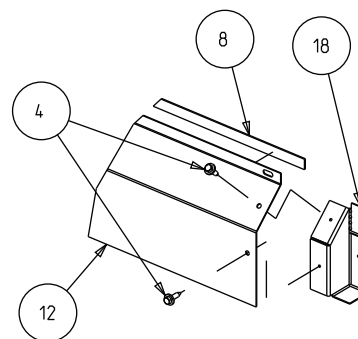
- a. For tall pitch side, hand bend the tab before installing the flashing guard.

Figure 63. Internal width 27.5 to 96 in. (des seq M or later), non-hurricane units



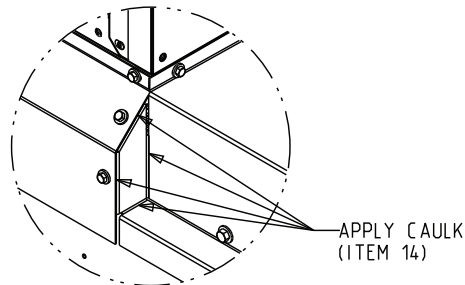
- b. Install flashing end cover. Figure below shows right-hand drive side.

Figure 64. Internal width 27.5 to 96 in. (des seq M or later), non-hurricane units



- c. See figure below for assembled view and apply caulk as indicated. Verify item 18 is behind the roof.

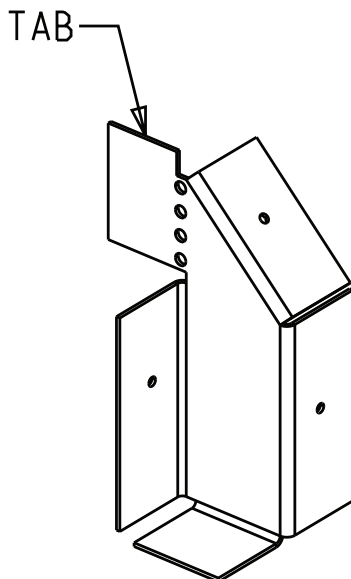
Figure 65. Internal width 27.5 to 96 in. (des seq M or later), non-hurricane units



Note: Low side – right hand (RH) drive side shown in the details below.

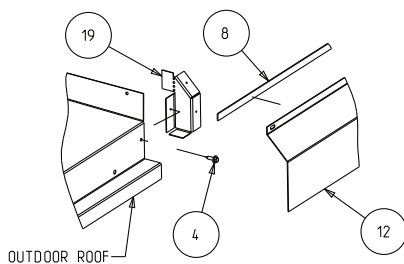
2. Assemble Skirt Support Bracket (Item 19) using Screw 10-16 x .750 self driller with outdoor roof panel at low side of the lower-level section.
 - a. Do NOT bend the tab for shorter pitch side roof.

Figure 66. Internal width 27.5 to 96 in. (des seq M or later), non-hurricane units



- b. Install flashing end cover.

Figure 67. Internal width 27.5 to 96 in. (des seq M or later), non-hurricane units



- c. See figure below for assembled view and apply caulk as indicated. Verify item 19 is behind the roof.

Figure 68. Internal width 27.5 to 96 in. (des seq M or later), non-hurricane units

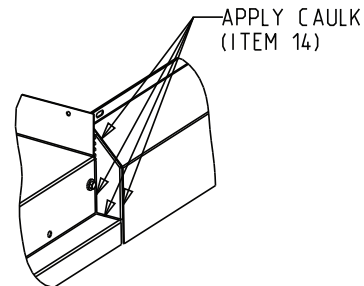
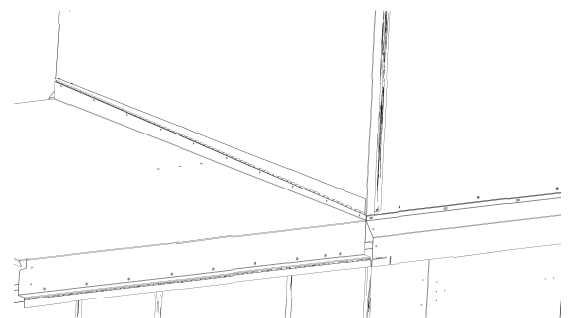


Figure 69. Flashing installation complete



Pipe Cabinet Installation

The pipe cabinet is an optional factory-supplied feature available through Trane Select Assist (TSA). It may also be referred to as a doghouse, pipe chase, service cabinet, or piping enclosure. External pipe cabinets are designed for outdoor units and provide protection for piping components associated with the access section.

Note: If a pipe cabinet is not selected but factory valves are selected, the valves must protected from the elements. A weatherized coil valve assembly is not currently offered. See *Water Valve Assembly Weatherproofing on CSAA/PSCA Outdoor units for more information.*

The cabinet has an open bottom to accommodate the roof during installation. Large access doors provide easy access to piping components for service and inspection. When multiple adjacent air-handling modules include the external pipe cabinet option, the factory supplies a single cabinet to accommodate them all. The single cabinet streamlines installation and maintenance, and provides more efficiency.

Important: The maximum combined cabinet length is 103 inches.

The foamed-panel cabinet assembly is not part of the unit airstream and, when properly installed, does not interfere with airflow or exhibit condensation. After pipefitting is complete, installing contractors must seal and insulate all piping entry locations to maintain system integrity and

Installation

efficiency. The factory supplies neoprene grommets for all factory-created entry locations. These adhere to the outer panel and fit snugly around any piping that extends beyond the wall panel.

Drain and vent hole options are available through TSA. If these options are not selected, the corresponding grommets will not be included with the coil panel, which could affect the piping system-to-coil interface.

Lifting Pipe Cabinets

1. Verify pipe cabinet cub and base are level and square.
2. Remove cross member before pulling the pipe cabinet close to the air handler casing. The channel is attached with four bolts and nuts.
3. Add 1 inch x 7.5 inch Armacell® gasketing to the inside of the pipe cabinet base rail.
4. Add a continuous line of 3/8 inch x 3/8 inch white Butyl tape to the face of all pipe cabinet surfaces that will contact the unit. See the details in the following figure.

Figure 70. Lifting pipe cabinets

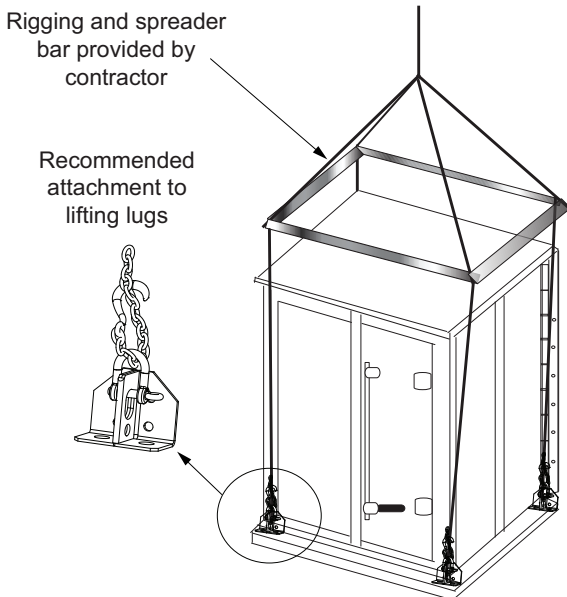


Table 6. Parts list - pipe cabinet installation, unit sizes 3 to 35

Item	Description
1	Armacell; 1 in. x 7.5 in. x 10 ft Roll
2	Screw; #10-16 x 0.75 in.
3	Butyl; 0.375 in. x 0.375 in. White

Unit Size CSAA 3 to 35 PSCA IW 27.5-96 inch (C-Channel Style Roof)

Figure 71. Pipe cabinet installation, unit sizes 3 to 35 (des seq M or later)

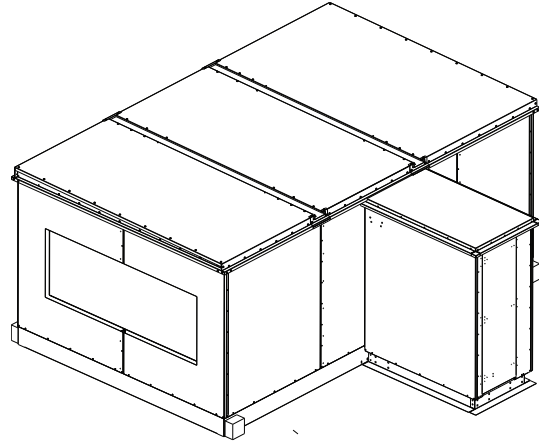


Figure 72. Pipe cabinet install before corner cap



Roof, Wall, Base Rail Butyl Application

Figure 73. Pipe cabinet installation, unit sizes 3 to 35 (des seq M or later)

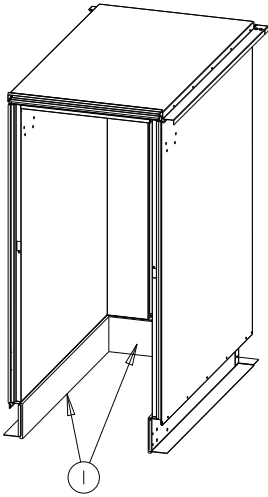


Figure 74. Pipe cabinet installation, unit sizes 3 to 35 (des seq M or later)

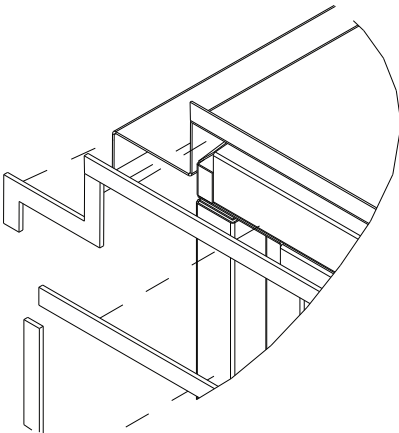
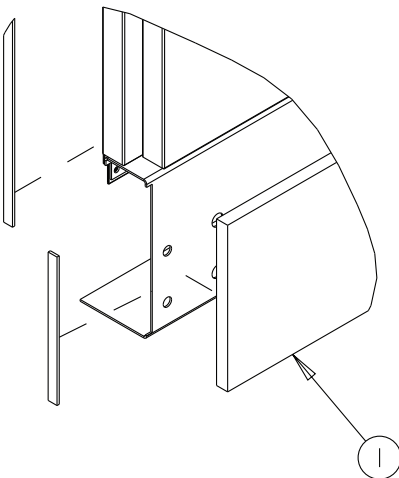


Figure 75. Pipe cabinet installation, unit sizes 3 to 35 (des seq M or later)



1. After installing all gasket and butyl as instructed, lift the pipe cabinet into position.
2. Pull the pipe cabinet tight to the unit casing using one of the methods described below. The appropriate method depends on the cabinet's location and the unit's specific design.
3. Attach the top roof flange to the unit casing using #10-16 x 0.75-inch screws.

Figure 76. Pipe cabinet roof screw detail



Unit Size CSAA 40 to 120 and PSCA IW 102 to 168 inch (Wide Roof Strip Style Roof)

Figure 77. Pipe cabinet installation, unit sizes 3 to 35 (des seq L or earlier) and 40 to 120

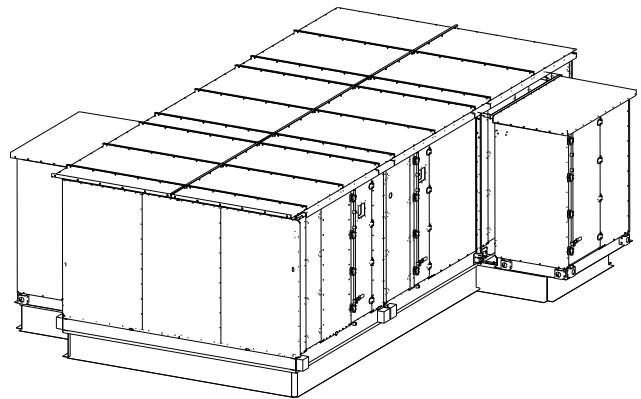


Figure 78. Pipe cabinet wide roof install



Roof, Wall, Base Rail Butyl Application

Figure 79. Pipe cabinet installation, unit sizes 3 to 35 (des seq L or earlier) and 40 to 120

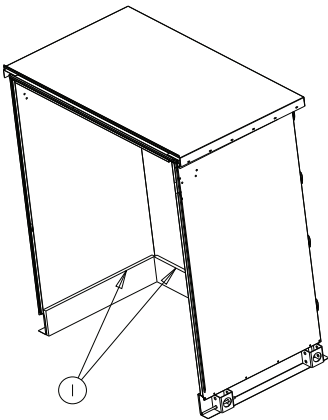


Figure 80. Pipe cabinet installation, unit sizes 3 to 35 (des seq L or earlier) and 40 to 120

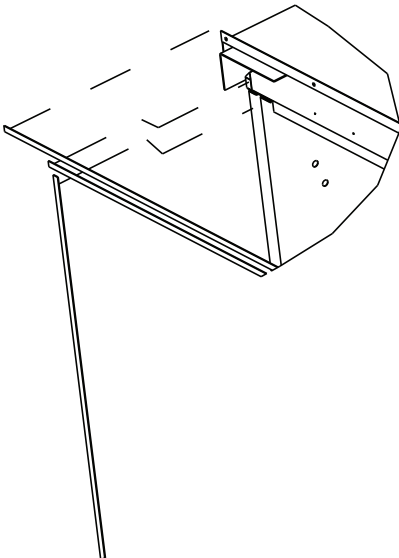
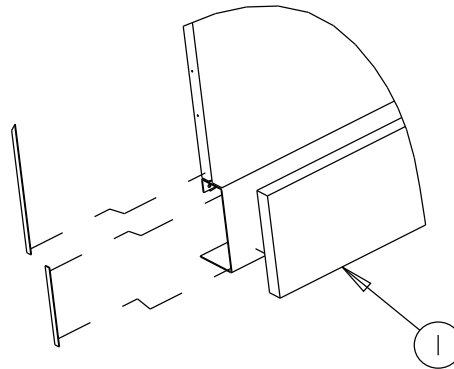


Figure 81. Pipe cabinet installation, unit sizes 3 to 35 (des seq L or earlier) and 40 to 120



1. After installing all gasket and butyl as instructed, lift the pipe cabinet into position.
2. Pull the pipe cabinet tight to the unit casing using one of the methods described below. The appropriate method depends on the cabinet's location and the unit's specific design.
3. Attach the top roof flange to the unit casing using #10-16 x 0.75-inch screws.

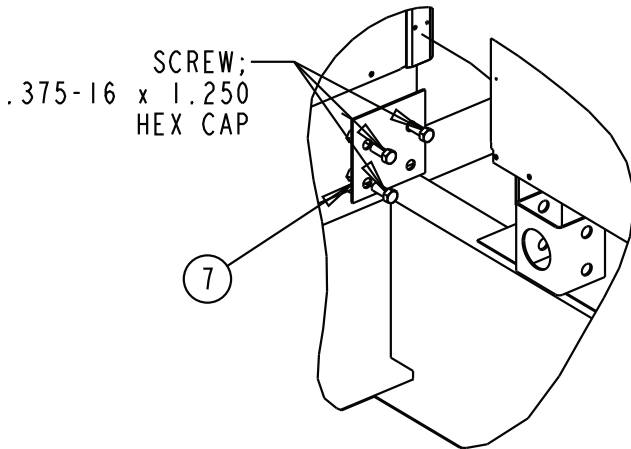
Pipe Cabinet to be Installed at Shipping Split Joint

Table 7. Pipe cabinet installation, unit sizes 3 to 35 (des seq L or earlier) and 40 to 120

Item	Description
4	Rod; 0.500-13 x 10.5 in.
5	1/2 in. Nut
6	1/2 in. Washer flat
7	Plate; Lug replacement

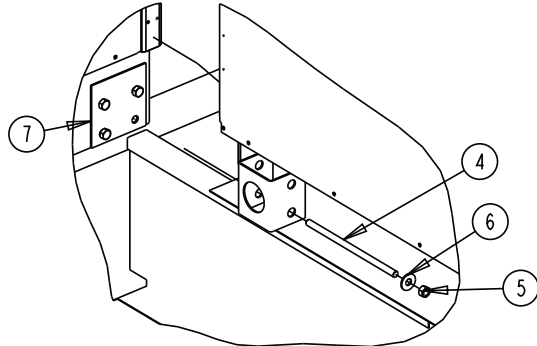
1. Remove the screws and lifting lug aligned with the pipe cabinet.
2. Install the black lug replacement plate (item 7) using the same three screws.

Figure 82. Pipe cabinet installation details



3. Slide the pipe cabinet into position, leaving sufficient access space.
4. Install the supplied threaded rod (item 4) clockwise through the pipe cabinet lifting lug and into the weld nut in the base rail.
5. Use the washer and nut on the rod to tighten the nut clockwise and pull the pipe cabinet firmly against the unit.

Figure 83. Pipe cabinet installation details



Pipe Cabinet to be Attached to Unit Base Bracket

1. Insert the threaded rod (Item 4) through the pipe cabinet lifting lug and into the welded bracket on the unit base rail.

Figure 84. Pipe cabinet installation details

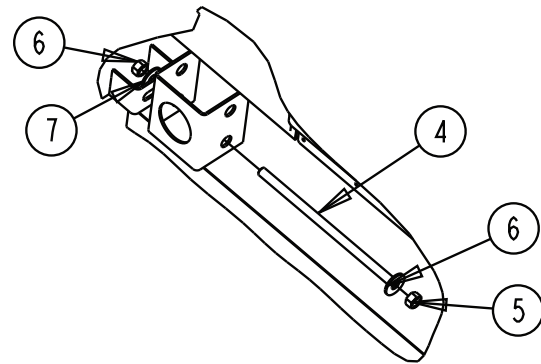


Figure 85. Pipe cabinet roof curb detail

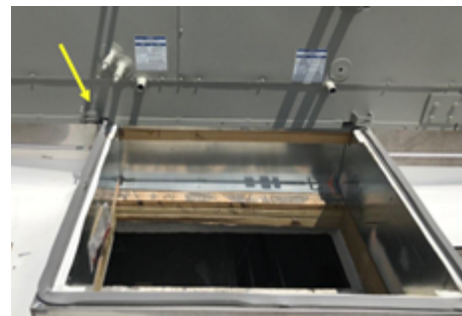


Figure 86. Pipe cabinet roof curb W bracket at unit base

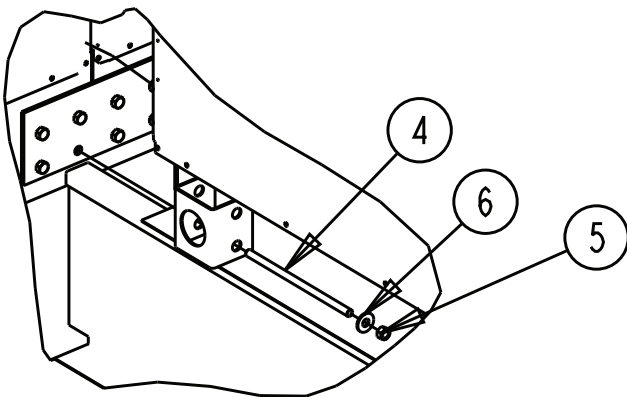


Figure 87. Pipe cabinet all thread at unit bracket detail


2. Install the provided washers and nuts on both ends of the rod.
3. Tighten the washers and nuts to pull the pipe cabinet firmly against the unit.

Pipe Cabinet to be installed at Factory Joint

1. Remove the lifting lug or splice plate screws aligned with the pipe cabinet lifting lug.
2. Thread the supplied threaded rod (Item 4) clockwise through the pipe cabinet lifting lug and into the weld nut in the base rail.
3. Install the washer and nut on the rod.
4. Tighten the nut on the rod clockwise to pull the pipe cabinet firmly against the unit.

Figure 88. Pipe cabinet installation details


Pipe Cabinet Corner Cap Installation

See Pipe Cabinet Corner Cap details on CSAA/PSCA AHUs for more details.

Corner caps are required to seal the exterior of the pipe cabinet to the unit seam and make it weather tight.

1. Verify the pipe cabinet exterior seam is sealed.
2. Apply 3/8 × 3/8-inch white butyl tape to both sides of each corner cap where it will contact the pipe cabinet and unit surfaces.

3. Install each corner cap on the inside corner using the provided 10-16 × 0.75 inch self-drilling screws.

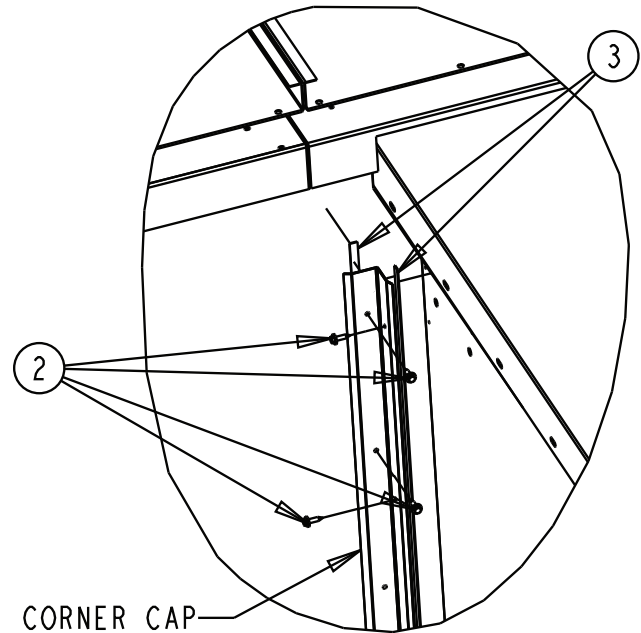
Figure 89. Pipe cabinet installation details

Figure 90. Pipe cabinet corner angle install


Figure 91. Pipe cabinet corner cap install



Hood Installation

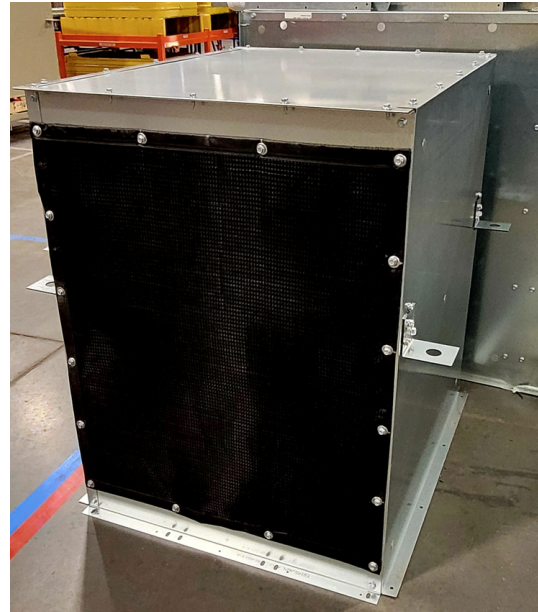
Outside Air (OA) intake hoods and Exhaust Air (EA) hoods are selectable in TSA, or they can be field provided. See Factory Hood Details for Field Fabricated hood CSAA/ PSCA/UCCA for more information.

Hood options and installation details are detailed in this section.

Figure 92. OA Hood pallet

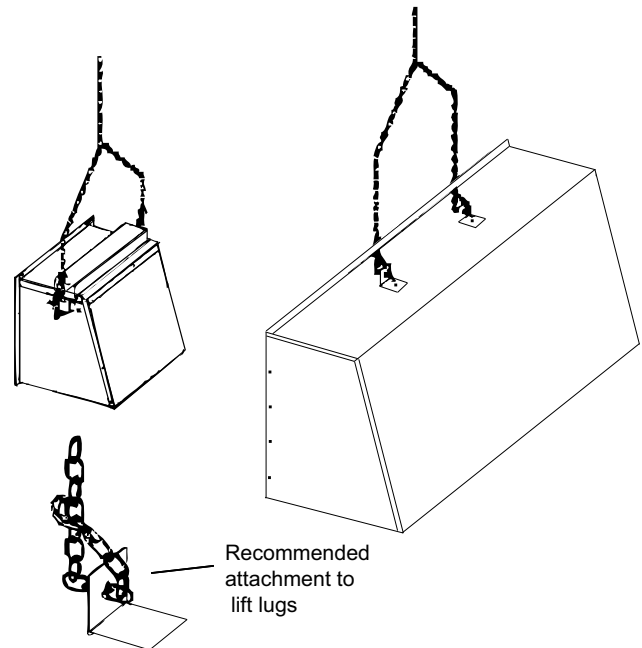


Figure 93. EA Hood



Lifting Hoods

Figure 94. Lifting inlet hurricane and exhaust hoods



1. See the mechanical layouts in the customer submittal package to identify the OA or EA hood locations. Verify that each unit opening matches the labeled inlet or exhaust hood received.
2. Apply the provided grey butyl tape to the hood flange with attachment holes.
3. Mount each hood to the unit using the factory-provided screws.

4. If required, install the bottom support angles. These attach to the baserail and may penetrate stacked flashing on second-level units. The angles ship attached to the hood and must be secured to the air-handler angle by the installing contractor. See Figure 98, p. 30.
5. Orient EA hoods as needed; they are flippable to direct airflow away from OA intake hoods.
6. For multi-piece standard inlet hoods, install sections one at a time from bottom to top. Seal all overlapping joints between sections with butyl tape.

Figure 95. Inlet hurricane and exhaust hood installation

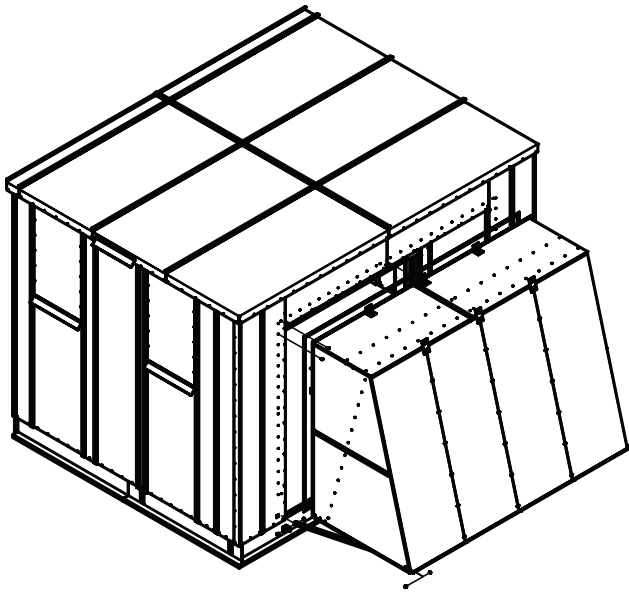
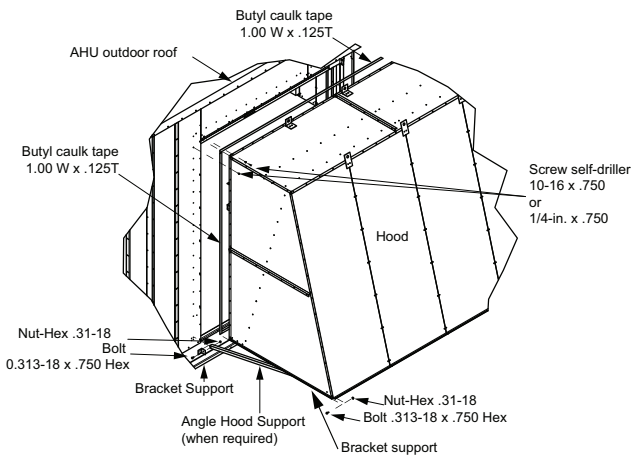


Figure 96. Inlet hurricane and exhaust hood installation



Upper-Level Hood Front/Back Mounted

Figure 97. Stacked unit assembly

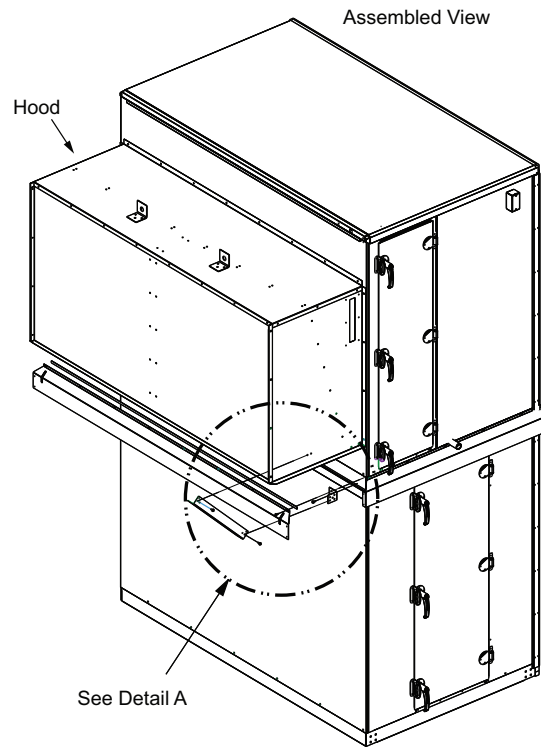


Figure 98. Stacked unit assembly – angle and guard installation

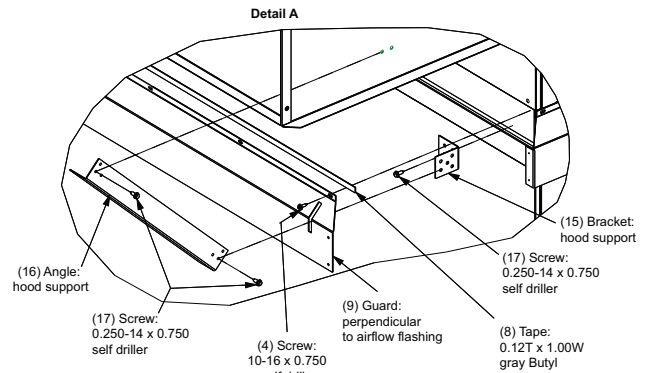
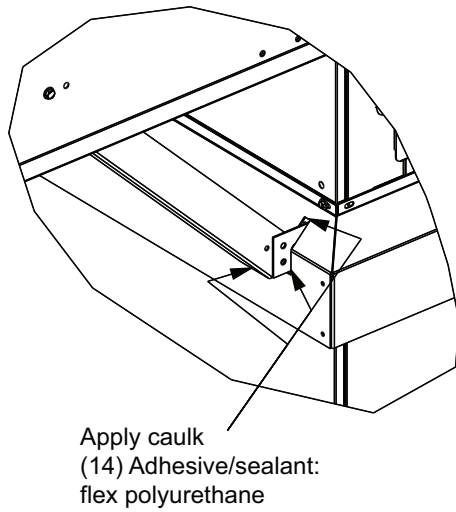


Figure 99. Stacked unit assembly - apply caulk



Standard Inlet Hood (Multiple Pieces)

Figure 100. Standard inlet hood installation

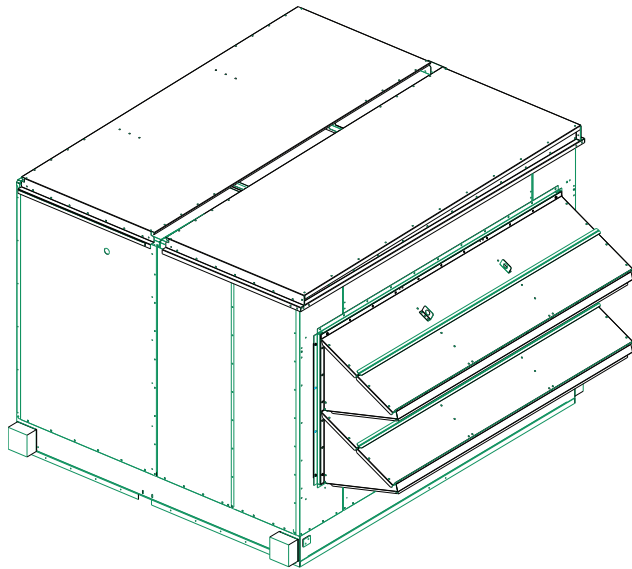
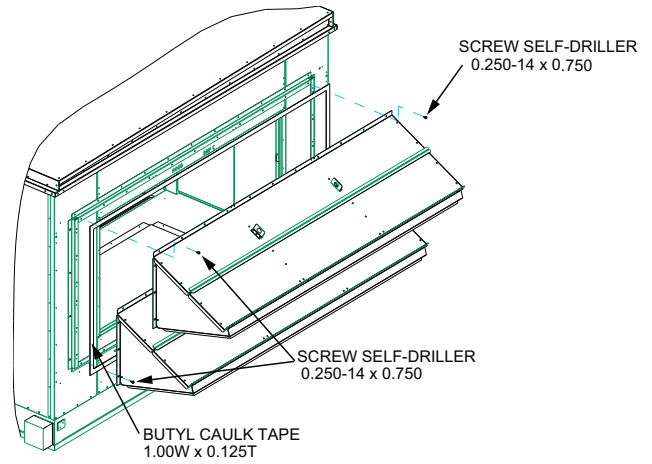


Figure 101. Standard inlet hood installation



Outside Air (OA) Hood

OA hoods can be mounted on the front, back, or side of the unit. The OA hoods regulate the amount of fresh outdoor air introduced into the system. Most codes specify a minimum outdoor-air percentage for occupancy. Consult local codes, the authority having jurisdiction (AHJ), and the project submittals for requirements.

Factory-supplied OA hoods include a removable Industrial EZ-KLEEN® moisture eliminator/permanent filter (UL-certified, rated 150 to 900 fpm; optimal 350 to 520 fpm). The eliminator filter track is enclosed on both sides by removable cover panels.

Figure 102. Exploded OA hood

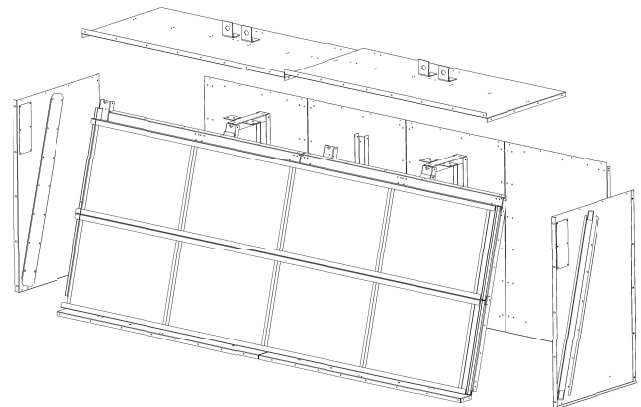
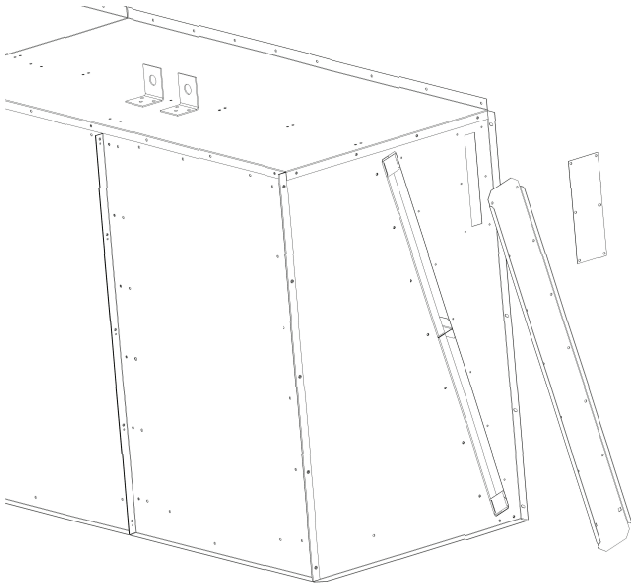


Figure 103. OA hood filter access panel**Side Mounted****Figure 104. Side mounted OA hood****Figure 105. Side mounted multiple hood****Back/Front Mounted****Figure 106. Back or front mounted OA hood****Figure 107. Front or back mounted multiple OA hood**

Exhaust Air (EA) Hood

EA hoods can be mounted on the front, back, or side of the unit. They must be oriented away from OA intake hoods to prevent exhaust air from being drawn back into the system, which can trigger alarms and degrade indoor air quality.

Side Mounted

Figure 108. Side exhaust hood



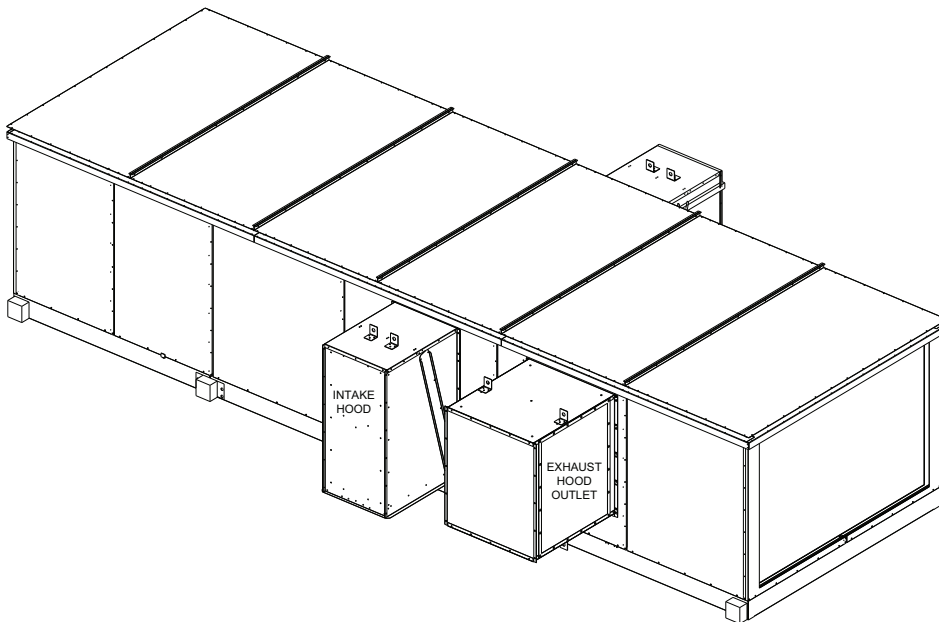
Front/Back Mounted

Figure 109. Front or back mounted EA hood



Fan Section side discharge exhaust hood installation (intake hood shape varies)

Figure 110. Fan section side discharge exhaust hood installation (intake hood shape varies)





Notes

Trane - by Trane Technologies (NYSE: TT), a global innovator - creates comfortable, energy efficient indoor environments for commercial and residential applications. For more information, please visit trane.com or tranetechnologies.com.

Trane has a policy of continuous product and product data improvements and reserves the right to change design and specifications without notice. We are committed to using environmentally conscious print practices.