



# Installation, Operation, and Maintenance

# Performance Climate Changer™

# Air Handlers

## Model PSCA



### **⚠ SAFETY WARNING**

Only qualified personnel should install and service the equipment. The installation, starting up, and servicing of heating, ventilating, and air-conditioning equipment can be hazardous and requires specific knowledge and training. Improperly installed, adjusted or altered equipment by an unqualified person could result in death or serious injury. When working on the equipment, observe all precautions in the literature and on the tags, stickers, and labels that are attached to the equipment.

July 2026

**CLCH-SVX018D-EN**

**TRANE**  
TECHNOLOGIES™



# Introduction

Read this manual thoroughly before operating or servicing this unit.

## Warnings, Cautions, and Notices

Safety advisories appear throughout this manual as required. Your personal safety and the proper operation of this machine depend upon the strict observance of these precautions.

The three types of advisories are defined as follows:



Indicates a potentially hazardous situation which, if not avoided, could result in death or serious injury.



Indicates a potentially hazardous situation which, if not avoided, could result in minor or moderate injury. It could also be used to alert against unsafe practices.



Indicates a situation that could result in equipment or property-damage only accidents.

## Important Environmental Concerns

Scientific research has shown that certain man-made chemicals can affect the earth's naturally occurring stratospheric ozone layer when released to the atmosphere. In particular, several of the identified chemicals that may affect the ozone layer are refrigerants that contain Chlorine, Fluorine and Carbon (CFCs) and those containing Hydrogen, Chlorine, Fluorine and Carbon (HCFCs). Not all refrigerants containing these compounds have the same potential impact to the environment. Trane advocates the responsible handling of all refrigerants.

## Important Responsible Refrigerant Practices

Trane believes that responsible refrigerant practices are important to the environment, our customers, and the air conditioning industry. All technicians who handle refrigerants must be certified according to local rules. For the USA, the Federal Clean Air Act (Section 608) sets forth the requirements for handling, reclaiming, recovering and recycling of certain refrigerants and the equipment that is used in these service procedures. In addition, some states or municipalities may have additional requirements that must also be adhered to for responsible management of refrigerants. Know the applicable laws and follow them.

### **⚠ WARNING**

#### **Proper Field Wiring and Grounding Required!**

Failure to follow code could result in death or serious injury.

All field wiring **MUST** be performed by qualified personnel. Improperly installed and grounded field wiring poses **FIRE** and **ELECTROCUTION** hazards. To avoid these hazards, you **MUST** follow requirements for field wiring installation and grounding as described in **NEC** and your local/state/national electrical codes.

### **⚠ WARNING**

#### **Personal Protective Equipment (PPE) Required!**

Failure to wear proper PPE for the job being undertaken could result in death or serious injury.

Technicians, in order to protect themselves from potential electrical, mechanical, and chemical hazards, **MUST** follow precautions in this manual and on the tags, stickers, and labels, as well as the instructions below:

- **Before installing/servicing this unit, technicians MUST put on all PPE required for the work being undertaken (Examples; cut resistant gloves/sleeves, butyl gloves, safety glasses, hard hat/bump cap, fall protection, electrical PPE and arc flash clothing). ALWAYS refer to appropriate Safety Data Sheets (SDS) and OSHA guidelines for proper PPE.**
- **When working with or around hazardous chemicals, ALWAYS refer to the appropriate SDS and OSHA/GHS (Global Harmonized System of Classification and Labelling of Chemicals) guidelines for information on allowable personal exposure levels, proper respiratory protection and handling instructions.**
- **If there is a risk of energized electrical contact, arc, or flash, technicians MUST put on all PPE in accordance with OSHA, NFPA 70E, or other country-specific requirements for arc flash protection, PRIOR to servicing the unit. NEVER PERFORM ANY SWITCHING, DISCONNECTING, OR VOLTAGE TESTING WITHOUT PROPER ELECTRICAL PPE AND ARC FLASH CLOTHING. ENSURE ELECTRICAL METERS AND EQUIPMENT ARE PROPERLY RATED FOR INTENDED VOLTAGE.**

**⚠ WARNING****Follow EHS Policies!**

Failure to follow instructions below could result in death or serious injury.

- All Trane personnel must follow the company's Environmental, Health and Safety (EHS) policies when performing work such as hot work, electrical, fall protection, lockout/tagout, refrigerant handling, etc. Where local regulations are more stringent than these policies, those regulations supersede these policies.
- Non-Trane personnel should always follow local regulations.

**⚠ WARNING****Cancer and Reproductive Harm!**

This product can expose you to chemicals including lead and bisphenol A (BPA), which are known to the State of California to cause cancer and birth defects or other reproductive harm. For more information go to [www.P65Warnings.ca.gov](http://www.P65Warnings.ca.gov).

**⚠ WARNING****R-454B or R-32 Flammable A2L Refrigerant!**

Failure to use proper equipment or components as described below could result in equipment failure, and possibly fire, which could result in death, serious injury, or equipment damage.

The equipment described in this manual uses R-454B or R-32 refrigerant which is flammable (A2L). Use **ONLY** R-454B or R-32 rated service equipment and components. For specific handling concerns with R-454B or R-32, contact your local representative.

**⚠ WARNING****Electrical Shock Hazard!**

Failure to follow instructions below could result in death or serious injury.

Properly connect the system's oversized protective earthing (grounding) terminal(s).

**NOTICE****Equipment Damage!**

Failure to follow instructions below could result in equipment damage.

This unit is a partial unit air conditioner, complying with partial unit requirements of standards listed, and must only be connected to other units that have been confirmed as complying to corresponding **PARTIAL UNIT** requirements of these Standards: UL 60335-2-40/CSA C22.2 No. 60335-2-40, or UL 1995/CSA C22.2 No 236.

## Additional Environmental Information

Air handler foamed panels rely on a foam system that utilizes water and R-1233zd as blowing agents.

## Copyright

This document and the information in it are the property of Trane, and may not be used or reproduced in whole or in part without written permission. Trane reserves the right to revise this publication at any time, and to make changes to its content without obligation to notify any person of such revision or change.

## Trademarks

All trademarks referenced in this document are the trademarks of their respective owners.

## Revision History

Updated seismic information.



# Table of Contents

General Information .....	7	Ignition Sources in Unit .....	18
Overview of Manual .....	7	Minimum Room Area Limits(R-454B	
Nameplate .....	7	charge greater than 3.91 lb per circuit	
Operating Environment .....	7	R-32 charge greater than 4.04 lb per	
Unit Description .....	7	circuit) .....	18
Components .....	7	Leak Detection System (R-454B	
Factory-Mounted Controls .....	7	charge greater than 3.91 lb per circuit	
Pre-Packaged Configurations for		or R-32 charge greater than 4.04 lb per	
Controls .....	7	circuit) .....	21
Wiring .....	8	Field Piping Installation and Charging .....	22
Pre-Installation .....	9	Installation – Mechanical .....	23
Receiving and Handling .....	9	Lifting and Rigging .....	23
Inspection .....	9	Remove Shipping Tie-Downs .....	23
Packaging/Shipping .....	9	General Lifting Considerations .....	23
Identification .....	9	Split to Split Orientation	
Handling .....	9	Instructions .....	24
Receiving Checklist .....	9	Lifting Hoods and Pipe Cabinets .....	25
Jobsite Storage .....	9	Forklifting Considerations .....	26
Outdoor Storage .....	9	Unit Placement and Assembly .....	26
Long-Term Storage .....	10	Removing the Shipping Skid .....	27
Site Preparation .....	10	Ceiling Suspension .....	28
Roof Curb Installation Checklist .....	10	Shipping Gussets .....	28
Dimensions and Weights .....	12	Section-to-Section Assembly .....	29
Installation Clearances (Electric Heat) .....	12	Pipe Cabinet Installation .....	35
Service Clearance Recommendations .....	12	Hood Installation .....	37
Fans/Motors .....	13	Stacked Outdoor Unit Assembly .....	39
VFD Weights .....	13	External Raceway Assembly .....	47
Motor Weights .....	13	Seismic Application Requirements .....	47
A2L Information and Installation		Single Level Design .....	47
Requirements .....	15	Stacked Design .....	48
Installation/Code Compliance		Anchoring .....	49
Requirements .....	15	Pipe Cabinet Installation .....	49
A2L Work Procedures .....	15	Component Installation .....	52
Servicing .....	15	Dampers .....	52
Leak Detection .....	16	Damper Torque Requirements .....	52
Refrigerant Removal and		Fans .....	52
Evacuation .....	16	Fan Isolation .....	52
Refrigerant Charging .....	17	Adjusting the Isolators .....	52
Decommissioning .....	17	Motor Removal Rail .....	53
A2L Application Considerations .....	17	Filters .....	53
Ignition Sources in Ductwork .....	18	Final Filter Section .....	53
		Pre-Filter Section .....	53
		Filter Installation .....	53
		Duct Connections .....	54

Fan Discharge Connections . . . . .	54	External Communications Port . . . . .	79
Damper Connections . . . . .	54	Start-Up . . . . .	80
Bottom Opening Duct Installation . . . . .	55	Pre-Startup Checklist . . . . .	80
Discharge Plenum Connections . . . . .	56	General Checks . . . . .	80
Bell Mouth Discharge		Fan-Related Checks . . . . .	80
Connections . . . . .	56	Coil-Related Checks . . . . .	80
Traq Damper Connections . . . . .	56	Motor-Related Checks . . . . .	80
Other Connections . . . . .	57	Unit Operation . . . . .	81
Piping and Connections . . . . .	58	Calculate Motor Voltage	
General Recommendations . . . . .	58	Imbalance . . . . .	81
Drain Pan Trapping . . . . .	58	VFD Programming Parameters . . . . .	81
Steam Coil Piping . . . . .	59	Airflow Measuring Systems . . . . .	82
Water Coil Piping . . . . .	60	Traq™ Dampers . . . . .	82
Refrigerant Coil Piping . . . . .	61	Fan Inlet Airflow Measuring	
Liquid Lines . . . . .	62	System . . . . .	84
Line Sizing . . . . .	62	Constant Factor K . . . . .	85
Routing . . . . .	62	External Insulating Requirements . . . . .	87
Insulation . . . . .	62	Routine Maintenance . . . . .	88
Components . . . . .	62	Maintenance Checklist . . . . .	88
Suction Lines . . . . .	63	Cleaning the Unit . . . . .	89
Line sizing . . . . .	63	Cleaning Non-Porous Surfaces . . . . .	89
Routing . . . . .	63	Cleaning Porous Surfaces . . . . .	89
Avoid Underground Refrigerant		Coils . . . . .	89
Lines . . . . .	63	Steam and Water Coils . . . . .	89
Insulation . . . . .	64	Refrigerant Coils . . . . .	90
Components . . . . .	64	Coil Winterization . . . . .	91
Expansion Valves . . . . .	64	Moisture Purge Cycle . . . . .	91
Hot Gas Bypass . . . . .	64	Drain Pans . . . . .	91
Humidifier Piping and Connections . . . . .	64	Fans . . . . .	92
Remodel, Retrofit, or Replacement . . . . .	65	Inspecting and Cleaning Fans . . . . .	92
Field-Installed Evaporator Piping . . . . .	66	Motor Bearing Lubrication . . . . .	92
Installation – Electrical . . . . .	71	Fan Motor Inspection . . . . .	92
Quick Connects . . . . .	72	Fan Block-off Plate . . . . .	92
Typical Wiring Schematics . . . . .	74	Filters . . . . .	93
Controls Interface . . . . .	78	Throwaway Filters . . . . .	93
Leak Detection Programming . . . . .	78	Permanent Filters . . . . .	93
Operator Display . . . . .	78	Cartridge or Bag Filters . . . . .	93
Connecting the Operator Display . . . . .	78	Moisture Eliminator . . . . .	93
Calibrating the Operator Display . . . . .	78	Ultraviolet (UV) Light Maintenance . . . . .	93
Adjusting Brightness and Contrast . . . . .	79	Cleaning the Bulbs . . . . .	94
		Replacing the Bulbs . . . . .	94
		Disposal of Bulbs . . . . .	94



## Table of Contents

---

Troubleshooting ..... 95



# General Information

## Overview of Manual

Use this manual to install, start-up, operate, and maintain the Performance Climate Changer™ air handler model PSCA. Carefully review the procedures discussed in this manual to minimize installation and startup difficulties.

## Nameplate

Each air handler section includes one or more nameplates or labels which identify the type of section and functional components, customer tagging information, unit serial number, unit sales order number, installation build section position, and unit model number.

**Note:** *Serial number and sales order number are required when requesting service or parts.*

## Operating Environment

The Performance Climate Changer™ air handler is a central station air handler for indoor and outdoor applications. When considering the placement of the air handler, it is important to consider the operating environment. The acceptable ambient temperature range for unit operation is -40°F to 140°F (-40°C to 60°C).

For heating applications, a special motor may be required to withstand the higher temperatures. Motors with Class B insulation are acceptable for ambient temperatures up to 104°F, while motors with Class F insulation can withstand ambient temperatures to 140°F (60°C).

**Note:** *Units with UL approval have a maximum ambient temperature requirement of 104°F. The customer should provide adequate freeze protection for the coils. See "Routine Maintenance," p. 88 for more information.*

## Unit Description

The Performance Climate Changer air handler is designed for a variety of controlled-air applications. The basic unit consists of a fan, heating and/or cooling coils, filters, and dampers.

## Components

Trane air handlers ship as complete assemblies or in subassemblies if shipping splits are required. Some assembly is required when the unit ships in sub-assemblies.

A wide variety of components is available for Trane air handlers, including numerous fan, coil, and filter options, access sections, discharge plenums, UL-approved electric heat sections, humidity management options, mixing boxes, moisture eliminator sections, exhaust dampers, controls, blenders, and airflow monitoring stations.

For more information, contact your local Trane sales office.

## Factory-Mounted Controls

Trane air handlers are available with a wide selection of factory-mounted controls, end devices, including Symbio™ controls, and variable frequency drives (VFD).

Most control components are mounted inside the unit. Depending on the system configuration, this may include damper actuators, dirty filter switches, averaging temperature sensors, and low limit switches. VFDs, new end devices, controllers, control transformers, static pressure transducers, DC power supplies, and customer interface relays will be in enclosures mounted on the inside of the unit.

Small items that cannot be factory-mounted, such as space temperature sensors, outside air temperature sensors, and humidity sensors, will ship inside the control enclosures, or packaged and shipped inside the fan or mixing box section. Larger items are shipped inside the fan section.

**Note:** *All control valves ship directly to the ship-to address from the vendor unless another address is given on the Trane sales order.*

All factory-mounted control systems (controls that are factorywired to a unit controller) ordered without variable-frequency drives (VFDs) are provided with 120 to 24 Vac control transformers mounted and wired in the auxiliary control panel. The customer must provide 120 Vac control power, 50/60 Hz, typically 5 amps. A dedicated 15-amp circuit is recommended.

Factory-mounted control systems ordered with factorymounted VFDs are supplied with line to 24 Vac control transformers. No additional power wiring is required.

## Pre-Packaged Configurations for Controls

If the air handler has been selected using one of Trane prepackaged solutions options for controls, there are a number of resources available to aid in commissioning and start-up of the unit. These resources include commissioning sheets, graphics and technical application notes. The technical application notes include the control sequencing, Trane Graphic Programming (TGP) and Rover set-up files for the specific unit selected. These resources are available through your local Trane sales office.

For more information on controls, refer to the following manuals:

- Programmable Symbio™ 500 controllers
  - *Symbio™ 500 Programmable Controller Installation, Operation, and Maintenance (BAS-SVX090\*-EN)*
  - *Installing the Tracer TD-7 Display (X39641191-01A)*
- TR150 Drives
  - *TR150 and TR170, Design Guide (BAS-SVX59\*-EN)*



## General Information

---

- TR150 and TR170, Programming Guide (BAS-SVP16\*-EN)

### Wiring

#### **⚠ WARNING**

##### **Proper Field Wiring and Grounding Required!**

Failure to follow code could result in death or serious injury.

All field wiring **MUST** be performed by qualified personnel. Improperly installed and grounded field wiring poses **FIRE** and **ELECTROCUTION** hazards. To avoid these hazards, you **MUST** follow requirements for field wiring installation and grounding as described in NEC and your local/state/national electrical codes.

#### **⚠ WARNING**

##### **Electrical Shock Hazard!**

Failure to follow instructions below could result in death or serious injury.

Properly connect the system's oversized protective earthing (grounding) terminal(s).

Entrances are generally provided for field-installation of high and low voltage wiring through a pipe/nipple connection in the unit depending on unit configuration with or without factory mounted controls. Before installation, consider overall unit serviceability and accessibility before mounting, running wires (power), making penetrations, or mounting any components to the cabinet.

Wiring to the air handler must be provided by the installer and must comply with all national and local codes. The fan motor nameplate includes a wiring diagram. If there are any questions concerning the wiring of the motor, write down the information on the motor nameplate and contact your local Trane sales office.



# Pre-Installation

## Receiving and Handling

### Inspection

Upon delivery, thoroughly inspect all components for any shipping damage that may have occurred, and confirm that the shipment is complete. See “Receiving Checklist,” p. 9 section for detailed instructions.

**Note:** *Delivery cannot be refused. All units are shipped F.O.B. factory. Trane is not responsible for shipping damage.*

### Packaging/Shipping

Performance air handlers ship as a complete unit or in individual sections to be field assembled. Indoor air handler sections are stretch-wrapped or shrink-wrapped before shipping. All factory shipping protection should be removed upon delivery. This wrapping is for transit protection only.

Indoor Performance air handlers ship in subassemblies if the total length of the units exceeds 98 inches or if the total weight exceeds factory limits.

Outdoor Performance air handler sections are not wrapped, but openings are covered to comply with LEED EQ Credit 5.

Smaller components and hardware may be shipped separately, or shipped inside the unit. This hardware is typically packaged in a clear plastic envelope or cardboard box, and can be found inside the fan, mixing box, or access section.

### Identification

Each air handler section includes a nameplate identifying the section type and functional components, customer tagging information, unit serial number, unit order number, the build section position for installation, and the unit model number. See “Nameplate,” p. 7.

### Handling

Air handlers have an integral base frame designed with the necessary number of lift points for safe installation. See “Lifting and Rigging,” p. 23.

### Receiving Checklist

Complete the following checklist immediately after receiving shipment to detect possible shipping damage.

- Check to confirm that the shipment is complete. Small components may ship inside the unit or ship separately. Check the parts list to confirm all materials are present. If any component is missing, contact your local Trane sales office.
- Check all units, components, connections, and piping. Check fan wheel for free rotation by spinning manually. Check all doors, latches, and hinges. Inspect interior of each unit or section. Inspect coils for damage to fin

surface and coil connections. Check for rattles, bent corners, or other visible indications of shipping damage. Tighten loose connections.

- If a unit is damaged, make specific notations concerning the damage on the freight bill. Do not refuse delivery.
- Notify the carrier terminal of the damage immediately by phone and mail. Request an immediate joint inspection of the damage by the carrier and consignee.
- Notify your Trane sales representative of the damage and arrange for repair. Do not attempt to repair the unit without consulting the Trane representative.
- Inspect the unit for concealed damage as soon as possible after delivery. Report concealed damage to the freight line. It is the receiver responsibility to provide reasonable evidence that concealed damage did not occur after delivery. Take photos of damaged material if possible.

**Note:** *Concealed damage must be reported to the Freight Carrier in writing within 5 business days of receipt.*

### Jobsite Storage

Indoor air handlers and field-installed accessories must be protected from the elements. A controlled indoor environment is recommended for proper storage.

**Note:** *All factory shipping protection should be removed. This wrapping is for transit protection only.*

The unit controller and all other electrical/electronic components should be stored in conditions of -20°F to 120°F and 5 to 95 percent relative humidity, non-condensing. Electrical components are not moisture-tolerant.

Outdoor units require no special protection for storage prior to installation.

### Outdoor Storage

#### **NOTICE**

#### **Unit Corrosion Damage!**

**Plastic tarps can cause condensation to form in and on the equipment, which could result in corrosion damage or wet storage stains.**

**Use only canvas tarps to cover equipment.**

Outdoor storage is not recommended for units that will be installed indoors. However, when outdoor storage is necessary, several things must be done to prevent damage:

**Note:** *Keep the equipment on the original wooden blocks/skid for protection and ease of handling.*

- Select a well-drained area, preferably a concrete pad or blacktop surface.



## Pre-Installation

- Place the unit on a dry surface or raised off the ground to assure adequate air circulation beneath the unit and to assure no portion of the unit will contact standing water at any time.
- Cover the unit securely with a canvas tarp.
- Do not stack units.
- Do not pile other material on the unit.

## Long-Term Storage

For longer periods of storage, allow proper clearance around the unit to perform periodic inspections and maintenance on the equipment. While the unit is in storage:

- Every two weeks, rotate the fan and motor shaft 30 revolutions by hand. Check for free rotation.
- Every six months, check fan shaft bearings and grease lines. Add grease using a manual grease gun.
- Check the motor lubrication; remove and clean grease plugs and check for the presence of moisture in the grease. If moisture is present, remove the motor and send it to an authorized repair shop for bearing inspection/ replacement. If no moisture is present, refer to the motor manufacturer lubrication recommendation for proper lubrication.

## Site Preparation

- Confirm the installation site can support the total weight of the unit (see “Dimensions and Weights,” p. 12 for approximate section weights; refer to the unit submittals for actual weights).
- Allow sufficient space for adequate free air and necessary service access (see “Service Clearance Recommendations,” p. 12). Refer to submittals for specific minimums.
- Allow room for supply and return piping, ductwork, electrical connections, and coil removal.
- Confirm there is adequate height for condensate drain requirements. See “Drain Pan Trapping,” p. 58.

**Note:** If unit is installed in a mechanical room on a pad, inadequate height may necessitate core-drilling the floor to attain proper trap height. Insufficient height could inhibit condensate drainage and result in flooding the unit and/or equipment room.

## NOTICE

### Microbial Growth!

Failure to follow instructions below could result in odors and damage to the equipment and building materials.

The floor or foundation must be level and the condensate drain at the proper height for proper drainage and condensate flow. Standing water and wet surfaces inside the equipment can become an amplification site for microbial growth (mold). If there is evidence of microbial growth on the interior insulation, it should be removed and replaced prior to operating the system.

- Confirm the roof curb or foundation of the mounting platform is level and large enough to accommodate the unit. Refer to the unit submittals for specific dimensions.
- Provide adequate lighting for maintenance personnel to perform maintenance duties.
- Provide permanent power outlets in close proximity to the unit for installation and maintenance.
- Depending upon job requirements, 120 Vac power may need to be provided for the unit controller. Refer to submittals for more information. A dedicated 15-amp circuit is recommended.
- Wiring for the air handler must be provided by the installer and must comply with all national and local electrical codes.
- If the unit integral base frame ceiling suspension provisions are not used, the installer/contractor must provide a ceiling-suspended mounting frame designed to support the length, width, and weight of the entire air handling unit. See “Ceiling Suspension,” p. 28 for more information.
- Rooftop curb-mounted units must be sealed tightly to the curb. Use proper sealants and roof-to-curb sealing techniques to prevent water and air leakage. Refer to *Roof Curbs for Performance Climate Changer™ Air Handlers Model CSAA and PSCA, Installation Instructions* (CLCH-SVN05\*-EN).

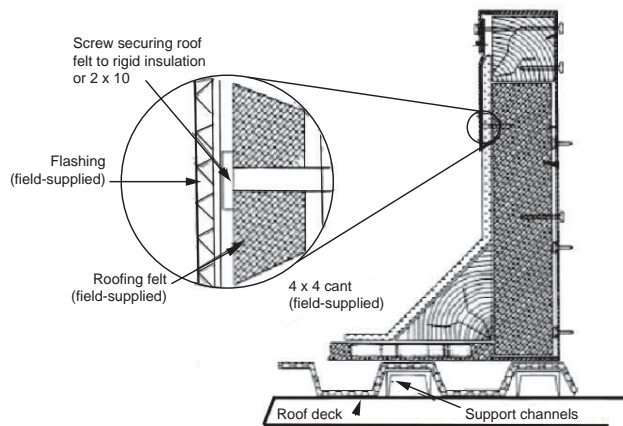
**Note:** Preparation of the roof curb or pier mount and roof openings should be completed prior to lifting the unit to the roof.

## Roof Curb Installation Checklist

Refer to *Roof Curbs for Performance Climate Changer™ Air Handlers Model CSAA and PSCA, Installation Instructions* (CLCH-SVN05\*-EN). for information on installing roof curbs.

It is recommended that the curb be installed directly on the support members and fastened to the supports using tack welds or other equivalent methods. Properly supported decking should be installed inside the air handler section of the curb when this method is used. See [Figure 1, p. 11](#).

**Figure 1. Cross section of typical curb installation on new construction**



1. Verify that the roof structure can adequately support the combined weight of the unit and curb assembly.
2. Ensure that the selected installation location provides sufficient service and operational clearances.
3. Remove any twist within the curb due to roof supports and square the curb.
4. Level the curb.
5. Secure the curb to the roof support members.
6. Install 2-inch thick boards or rigid insulation around the curb.
7. Install cant strips around the curb.
8. Bring field supplied roofing felt up to the top of the curb nailing strips. Nail felt into place.
9. Install field supplied flashing under the lip of the curb flanges and over the felt.
10. Apply sealant to the four corners.
11. Caulk all joints between the curb and the roof.

Attach the gasket material to the curb top flanges (entire perimeter) and to the supply and return air duct opening panel flanges.



# Dimensions and Weights

## Installation Clearances (Electric Heat)

Table 1. Electric heat requirements

Electric Heat Model	Minimum Clearance to Combustible Materials (inch)	Maximum Output Air Temperature (°F)	Maximum External Static Pressure (WC)
Draw-thru	0	104	—
Blow-thru	3 (first four feet of duct — duct, through transitions and turns)	200	—
	0 (after first four feet of duct)		
Duct Mounted	3 (first four feet of duct)	200	4

## Service Clearance Recommendations

Figure 2. Service clearance for indoor units

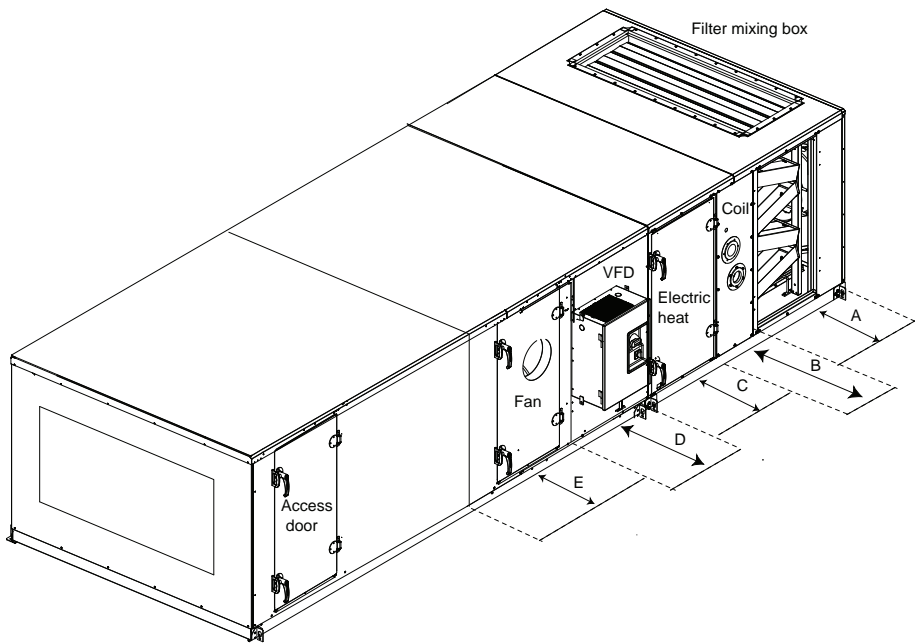


Table 2. Service clearance dimensions (inches)

Component	Width											
	48	54	62.5	68	72	76	84	90	96	102	109	114
A (filter)	48	48	48	48	48	48	48	48	48	48	48	48
B (coil)	64	70	79	84	88	92	100	106	112	118	125	130
C (electric heat coil)	54	60	69	74	78	82	90	96	102	108	115	120
C (UV lights)	48	48	48	48	48	48	48	48	48	48	48	48
C (TCAPS)	48	48	48	48	48	48	48	48	48	48	48	48

**Table 2. Service clearance dimensions (inches) (continued)**

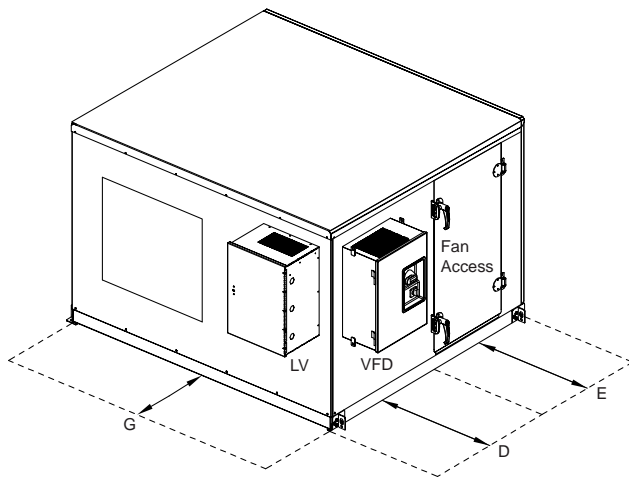
Component	Width											
	48	54	62.5	68	72	76	84	90	96	102	109	114
D (external VFD)	64	64	64	64	64	64	64	64	64	64	64	64
D (internal VFD)	48	48	48	48	48	48	48	48	48	48	48	48
E (fan)	54	54	54	60	60	60	66	66	66	66	70	70

Component	Width											
	122	126	132	136.5	144	150.5	156	162	168	174	178	
A (filter)	48	48	48	48	48	48	48	48	48	48	48	
B (coil)	138	142	148	153	160	167	172	178	184	190	194	
C (electric heat coil)	128	132	138	143	150	157	162	168	174	180	184	
C (UV lights)	48	48	48	48	48	48	48	48	48	48	48	
C (TCAPS)	48	48	48	48	48	48	48	48	48	48	48	
D (external VFD)	64	64	64	64	64	64	64	64	64	64	64	
D (internal VFD)	48	48	48	48	48	48	48	48	48	48	48	
E (fan)	77	77	77	77	93	93	101	101	101	101	101	

**Note:** At a minimum, the above clearance dimensions are recommended on one side of the unit for regular service and maintenance. Refer to as-built submittal for locations of items such as filter access doors, coil, piping connections, motor locations, etc. Sufficient clearance must be provided on all sides of unit for removal of access panels, plug panels, or section-to-section attachment brackets. Clearance for VFDs, or other high-voltage devices must be provided per NEC requirements. For specific dimensional and weight information, refer to the unit submittals. The dimensions and weights in this manual are approximate. Trane has a policy of continuous product and product data improvement and reserves the right to change design and specifications without notice.

**Figure 3. Service clearance for control box**



**Table 3. Service clearance dimensions (inches) for control box**

HV Component	LV Component	All sizes	
VFD	None	G	36.00

### Fans/Motors

**Note:** Trane has a Precision Motor™ option for direct-drive plenum fans. This offering takes a general purpose motor and re-rates the motor for higher rated loads. This maximizes part-load motor efficiency and precisely sizes the motor for the application. To use these tables, the **nameplate hp** of the motor and the VFD—both of which will be greater than the Precision Motor hp – must be known.

### VFD Weights

With the exception of motorized impellers, fan weight does not include VFD weight. See [Table 4, p. 13](#) for approximate VFD weight.

**Table 4. Approximate VFD weights per horsepower (lbs.)**

Horsepower	1	1 1/2	2	3	5	7 1/2	10	15	20	25	30	40	50	60	75	100	125
VFD <sup>(a)</sup>	123	123	132	124	125	136	151	162	177	197	241	325	332	243	258	294	314

<sup>(a)</sup> Weights include transformer, distribution block, and enclosure.

### Motor Weights

Fan weights provided in this manual include the heaviest ODP (open drip-proof) motor. In the case of motorized impellers, fan weights include the packaged motor.



## Dimensions and Weights

**Table 5. Approximate motor weights (pounds)**

Motor Type	Motor RPM	Horsepower																	
		3/4	1	1-1/2	2	3	5	7-1/2	10	15	20	25	30	40	50	60	75	100	125
Energy efficient ODP (EEOP)	1800	24	29	—	—	—	—	—	—	—	—	—	—	—	—	—	—	—	—
NEMA Premium ODP (HEOP)	1200	—	39	77	91	147	126	249	300	375	443	594	667	—	—	—	—	—	—
NEMA Premium TEFC (HETC)		—	56	96	109	148	185	310	341	423	481	614	655	—	—	—	—	—	—
NEMA Premium ODP (HEOP)	1800	—	36	42	47	76	82	118	148	234	263	330	379	488	521	698	808	1114	1238
NEMA Premium TEFC (HETC)		—	47	54	56	91	108	159	185	285	315	452	481	578	670	808	889	1239	1466
NEMA Premium ODP (HEOP)	3600	—	36	36	37	89	104	173	203	267	243	261	407	—	—	—	—	—	—
NEMA Premium TEFC (HETC)		—	36	53	62	85	103	154	176	287	322	448	496	—	—	—	—	—	—



# A2L Information and Installation Requirements

## Installation/Code Compliance Requirements

Building level controls may need to be upgraded/modified to demand leak mitigation actions as described in “Leak Detection System

(R-454B charge greater than 3.91 lb per circuit or R-32 charge greater than 4.04 lb per circuit),” p. 21.

Those actions include, but are not limited to, fully opening damper and VAV boxes (if present), and disabling electric heat in VAV boxes (if present).

Verify the equipment refrigerant charge is in accordance with the room area limitation as described in Minimum Room Area Limits section.

Ensure that there are labels on the equipment stating it contains a flammable refrigerant.

## A2L Work Procedures

### **⚠ WARNING**

#### **Risk of Fire — Flammable Refrigerant!**

Failure to follow instructions below could result in death or serious injury, and equipment damage.

- To be repaired only by trained service personnel.
- Do not puncture refrigerant tubing.
- Dispose of properly in accordance with federal or local regulations.
- The equipment shall be stored in a room without continuously operating ignition sources.

### **⚠ WARNING**

#### **Refrigerant under High Pressure!**

Failure to follow instructions below could result in an explosion which could result in death or serious injury or equipment damage.

System contains refrigerant under high pressure. Recover refrigerant to relieve pressure before opening the system. See unit nameplate for refrigerant type. Do not use non-approved refrigerants, refrigerant substitutes, or refrigerant additives.

### **⚠ WARNING**

#### **Hazardous Voltage!**

Failure to disconnect power before servicing could result in death or serious injury.

Disconnect all electric power, including remote disconnects before servicing. Follow proper lockout/tagout procedures to ensure the power can not be inadvertently energized. Verify that no power is present with a voltmeter.

The units described in this manual use R-454B or R-32 refrigerant. Use ONLY R-454B or R-32 rated service equipment or components with these units. For specific handling concerns with R-454B or R-32, contact your local Trane representative.

Installation, repair, removal, or disposal should be performed by trained service personnel.

At all times, Trane’s maintenance and service guidelines shall be followed. If in doubt, contact Trane technical support for assistance.

## Service

Prior to initiating work on equipment, check the area with an appropriate refrigerant detector. Ensure the service personnel are properly trained regarding work in potentially toxic or flammable atmospheres. Ensure that the leak detection equipment being used is suitable for use with all applicable refrigerants, i.e. non-sparking, adequately sealed, or intrinsically safe. Be aware that the refrigerant does not contain an odor.

If any hot work is to be conducted on the refrigerating equipment or any associated parts, appropriate fire extinguishing equipment shall be available on hand. A dry powder or CO<sub>2</sub> fire extinguisher should be located adjacent to the charging area.

At all times, Trane’s maintenance and service guidelines shall be followed. If in doubt, contact Trane technical support for assistance.

All maintenance staff and others working in the local area shall be instructed on the nature of the work being carried out. Work in confined spaces shall be avoided.

## Ignition Source Mitigation

Do not use any sources of ignition when working on the refrigeration system.

Keep all ignition sources, including cigarette smoking, away from the site of installation, repair, removal or disposal, during which refrigerant can potentially be released to the surrounding space.

Survey the area around the equipment before initiating work to ensure no flammable hazards or ignition risks are present.

“No Smoking” signs shall be displayed.



## A2L Information and Installation Requirements

Do not use devices that can be a source of ignition to accelerate defrosting of components. Use only defrost and cleaning procedures recommended by Trane. Do not pierce or burn.

### Ventilation

Ensure that the area is in the open or that it is adequately ventilated before breaking into the system or conducting any hot work. A degree of ventilation shall continue during the period that the work is carried out. The ventilation should safely disperse any released refrigerant and preferably expel it externally into the atmosphere. If present, check that the ventilation system, including outlets, are operating adequately and are not obstructed.

### Refrigerating Equipment

Refrigerant piping or components should not be installed in locations where substances which may corrode them are present.

Check that equipment hazard markings are visible and legible. Replace them if they are not.

For equipment using secondary fluids, like water or glycol, check that refrigerant is not present in the secondary fluid loop before conducting any hot work.

### Electrical Devices

Do not apply power to the circuit if a fault exists which compromises safety. If the fault cannot be corrected immediately, but it is necessary to continue operation, an adequate temporary solution shall be used. This shall be reported to the owner of the equipment, so all parties are advised.

Initial safety checks shall include:

- Cabling is not subject to wear, corrosion, excessive pressure, vibration, sharp edges, or any other adverse environmental effects. Account for the effects of aging or continual vibration from sources such as compressors or fans.
- Capacitors are discharged. This shall be done in a safe manner to avoid possibility of sparking.
- No live electrical components and wiring are exposed while charging, recovering, or purging the system.
- Verify continuity of earth bonding.
- Replace electrical components with Trane replacement parts, or those meeting the same ratings and qualified for flame arrest protection, UL LZGH2 category.

### Leak Detection

Never use an open flame to detect leaks. A halide torch should not be used. Use only approved leak detection methods per this instruction manual.

The following leak detection methods are deemed acceptable for all refrigerant systems.

Electronic leak detectors may be used to detect refrigerant leaks but, in the case of flammable refrigerants, the sensitivity may not be adequate, or may need re-

calibration. (Detection equipment shall be calibrated in a refrigerant-free area.) Verify the detector is not a potential source of ignition and is suitable for the refrigerant used. Leak detection equipment shall be set at a percentage of the LFL gas (25% maximum) is confirmed.

Leak detection fluids are also suitable for use with most refrigerants but the use of detergents containing chlorine shall be avoided as the chlorine may react with the refrigerant and corrode the copper pipe-work.

Examples of leak detection fluids are:

- Bubble method
- Fluorescent method agents

If a leak is suspected, all naked flames shall be removed/ extinguished.

If a refrigerant leak is found which requires brazing, all refrigerant shall be recovered from the system, or isolated (by means of shut-off valves) in a part of the system remote from the leak.

### Refrigerant Removal and Evacuation

Ensure that the correct number of cylinders for holding the total system charge is available. All cylinders to be used are designated for the recovered refrigerant and labeled for that refrigerant (special cylinders for the recovery of refrigerant, for example). Cylinders shall be complete with pressure-relief valve and associated shut-off valves in good working order. Empty recovery cylinders are evacuated and, if possible, cooled before recovery occurs.

When breaking into the refrigerant circuit to make repairs – or for any other purpose – conventional procedures shall be used. However, for flammable refrigerants it is important that best practice be followed, since flammability is a consideration.

The following procedure shall be adhered to:

1. Safely remove refrigerant following local and national regulations.
2. Evacuate.
3. Purge the circuit with inert gas.
4. Evacuate (optional for A2L).
5. Continuously flush or purge with inert gas when using flame to open circuit.
6. Open the circuit.

Prior to refrigerant removal, open all appropriate valves, including solenoid and electronic expansion valves (EXVs). Use control settings, where available. When not available, manually open all electronically controlled valves using acceptable service procedures.

The recovery equipment shall be in good working order with instructions available. Equipment shall be suitable for the recovery of the flammable refrigerant. For specific handling concerns, contact the manufacturer. Ensure all hose connections are checked for tightness to avoid refrigerant leaks.

In addition, a set of calibrated weighing scales shall be available and in good working order.

The refrigerant shall be recovered into the correct recovery cylinders if venting is not allowed by local and national codes. Do not mix refrigerants in recovery unit and especially not in cylinders.

Refrigerant recovery unit should be purged with an inert gas after each use or before using with a different refrigerant Class – for example, A2L to A1.

If compressors or compressor oils are to be removed, ensure that they have been evacuated to an acceptable level to make certain that flammable refrigerant does not remain within the lubricant. The compressor body shall not be heated by an open flame or other ignition sources to accelerate this process. When oil is drained from a system, it shall be carried out safely.

The system shall be purged with oxygen-free nitrogen to render the appliance safe for flammable refrigerants. This process might need to be repeated several times. Compressed air or oxygen shall not be used for purging refrigerant systems.

The system shall be vented down to atmospheric pressure to enable work to take place.

The outlet for the vacuum pump shall not be close to any potential ignition sources, and ventilation shall be available.

### Refrigerant Charging

In addition to conventional charging procedures, the following requirements shall be followed.

- Ensure that contamination of different refrigerants does not occur when using charging equipment.
- Hoses or lines shall be as short as possible to minimize the amount of refrigerant contained in them.
- Cylinders shall be kept in an appropriate position according to the instructions.
- Ensure that the refrigerating system is earthed prior to charging the system with refrigerant.
- Label the system when charging is complete (if not already).
- Extreme care shall be taken not to overfill the refrigerating system.

Prior to recharging the system, it shall be pressure-tested with the appropriate purging gas. The system shall be leak-tested on completion of charging but prior to commissioning. A follow up leak test shall be carried out prior to leaving the site.

Prior to refrigerant charging, open all appropriate valves, including solenoid and electronic expansion valves (EXVs). Use control settings, where available. When not available, manually open all electronically controlled valves using acceptable service procedures.

Verify the equipment refrigerant charge is in accordance with the room area limitation as described in Minimum Room Area Limits section.

### Decommissioning

Before carrying out the decommissioning procedure, it is essential that the trained service personnel is completely familiar with the equipment and all its details. It is recommended good practice that all refrigerants are recovered safely. Prior to the task being carried out, an oil and refrigerant sample shall be taken in case analysis is required prior to re-use of recovered refrigerant. It is essential that electrical power is available before the task is commenced.

1. Become familiar with the equipment and its operation.
2. Isolate system electrically.
3. Before attempting the procedure, ensure that:
  - a. Mechanical handling equipment is available, if required, for handling refrigerant cylinders.
  - b. All personal protective equipment is available and being used correctly.
  - c. The recovery process is supervised at all times by a competent person.
  - d. Recovery equipment and cylinders conform to the appropriate standards.
4. Pump down refrigerant system, if possible.
5. If a vacuum is not possible, make a manifold so that refrigerant can be removed from various parts of the system.
6. Make sure that cylinder is situated on the scales before recovery takes place.
7. Start the recovery machine and operate in accordance with instructions.
8. Do not overfill cylinders (no more than 80% volume liquid charge).
9. Do not exceed the maximum working pressure of the cylinder, even temporarily.
10. When the cylinders have been filled correctly and the process completed, make sure that the cylinders and the equipment are removed from site promptly and all isolation valves on the equipment are closed off.
11. Recovered refrigerant shall not be charged into another refrigerating system unless it has been cleaned and checked.
12. When equipment has been decommissioned, attach a signed and dated label stating it has been decommissioned and emptied of refrigerant.
13. Ensure that there are labels on the equipment stating it contains flammable refrigerant.

### A2L Application Considerations

This product is listed to UL standard 60335-2-40, Household and Similar Electrical Appliances – Safety – Part 2-40: Particular Requirements for Electrical Heat Pumps, Air-Conditioners and Dehumidifiers, which defines safe design and use strategies for equipment using A2L



## A2L Information and Installation Requirements

refrigerants. This standard limits the refrigerant concentration in a space in the event of a refrigerant leak. To meet the requirements, the UL standard defines minimum room area, refrigerant charge limit, minimum circulation airflow and/or ventilation airflow requirements, and limits the use of ignition sources in spaces. The standard may require a unit refrigerant leak detection system.

For equipment with either:

- R-454B and charge amounts less than or equal to 3.91 lbs per circuit
- R-32 and charge amounts less than or equal to 4.04 lbs per circuit

this UL standard does not prescribe a room area limit and does not require a refrigerant leak detection system or any circulation airflow or ventilation airflow mitigation strategies. However, ignition sources in ductwork must be evaluated.

Depending on the application, a specific requirement of ANSI/ASHRAE Standard 15, Safety Standard for Refrigeration Systems, could be more stringent than UL 60335-2-40 requirements. See *Refrigeration Systems and Machinery Rooms Application Considerations for Compliance with ASHRAE® Standard 15-2022 Application Engineering Manual* (APP-APM001\*-EN) for more information.

### Ignition Sources in Ductwork

Do not install open flames in the ductwork. Hot surfaces exceeding 700°C (1290°F) should not be installed in the ductwork unless the average airflow velocity is not less than 1.0 m/s (200 ft/min) across the heater and proof of airflow is verified before system is energized.

Electric heaters can exceed the surface temperature limit if airflow distribution is poor, or insufficient airflow is provided over the heater.

Surface temperatures of most gas heaters do not exceed the surface temperature limits due to ANSI construction requirements.

### Ignition Sources in Unit

This unit does not contain any ignition sources. All potential ignition sources, (including factory or field installed accessory electric heaters, gas heaters, relays, and contactors) were evaluated during product UL listing.

### Minimum Room Area Limits (R-454B charge greater than 3.91 lb per circuit or R-32 charge greater than 4.04 lb per circuit)

Equipment with charge amounts greater than values in the table below may require additional circulation or ventilation airflow mitigation strategies.

**Table 6. Refrigerant charge for additional mitigation strategies**

Refrigerant	Change (lb per circuit)
R-454B	3.91
R-32	4.04

In this case, there are two minimum room area ( $A_{min}$ ) thresholds.

- The first threshold defines when equipment serving a single room is required to provide circulation airflow, either continuous or activated by a leak detection system. A ducted system requires circulation airflow unless the smallest room it serves is larger than the adjusted  $A_{min}$  threshold. This product contains a leak detection system if a circuit charge is greater than values shown in [Table 6, p. 18](#). As a result, no further leak detection system evaluation is needed.
- The second threshold defines when additional ventilation airflow is required. If the room area,  $A$  or  $TA$ , is below the adjusted  $A_{min}$  or  $TA_{min}$  threshold, additional ventilation is required to remove refrigerant in the event of a leak. Refer to UL 60335-2-40 Clause GG.8 and ANSI/ASHRAE Standard 15 Section 7 for natural and mechanical ventilation requirements. See equipment nameplate and table below for minimum room area.

Split systems minimum room area requirements need to be determined after final field charging. Use the following figures and the largest final circuit charge to determine the systems  $A_{min}$  value. Record the final charge value on the label provided on the condensing unit.

Figure 4. R-454B charge vs min room area (IP)

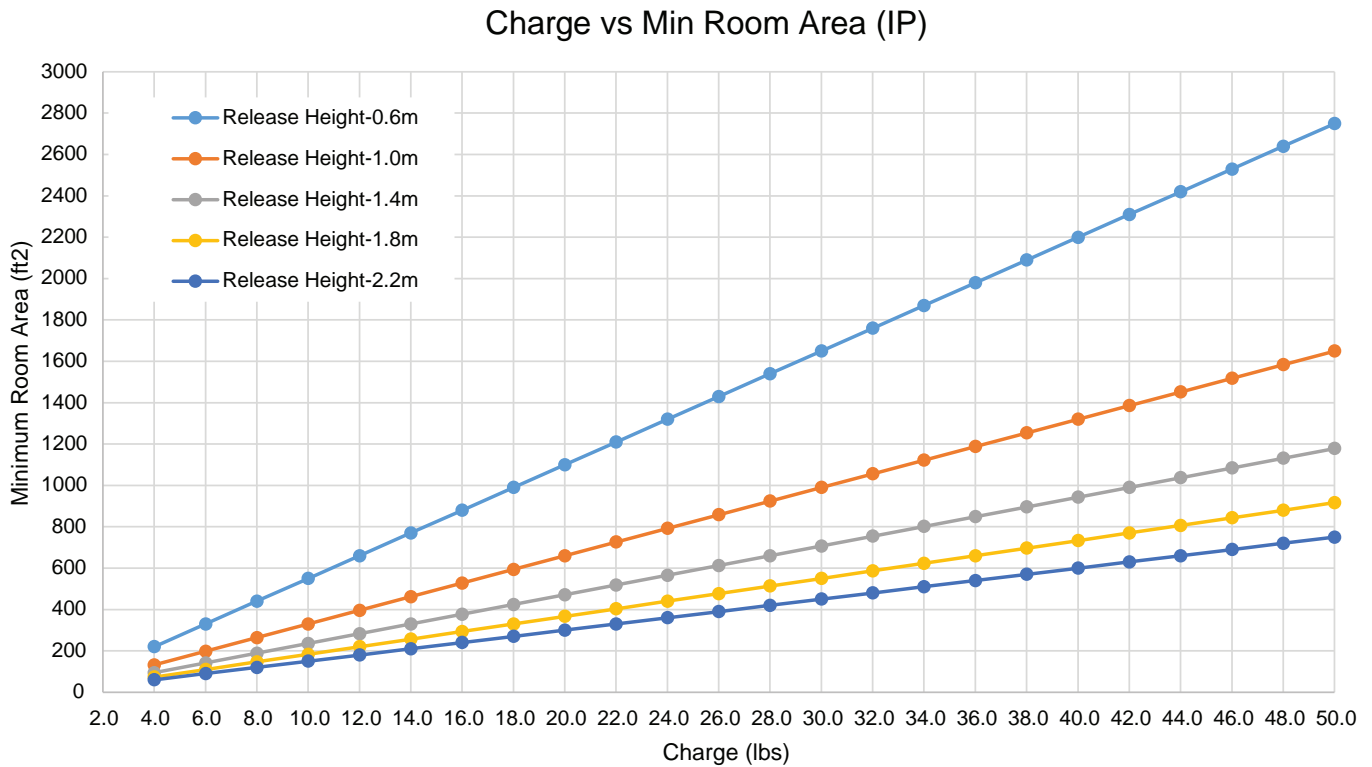
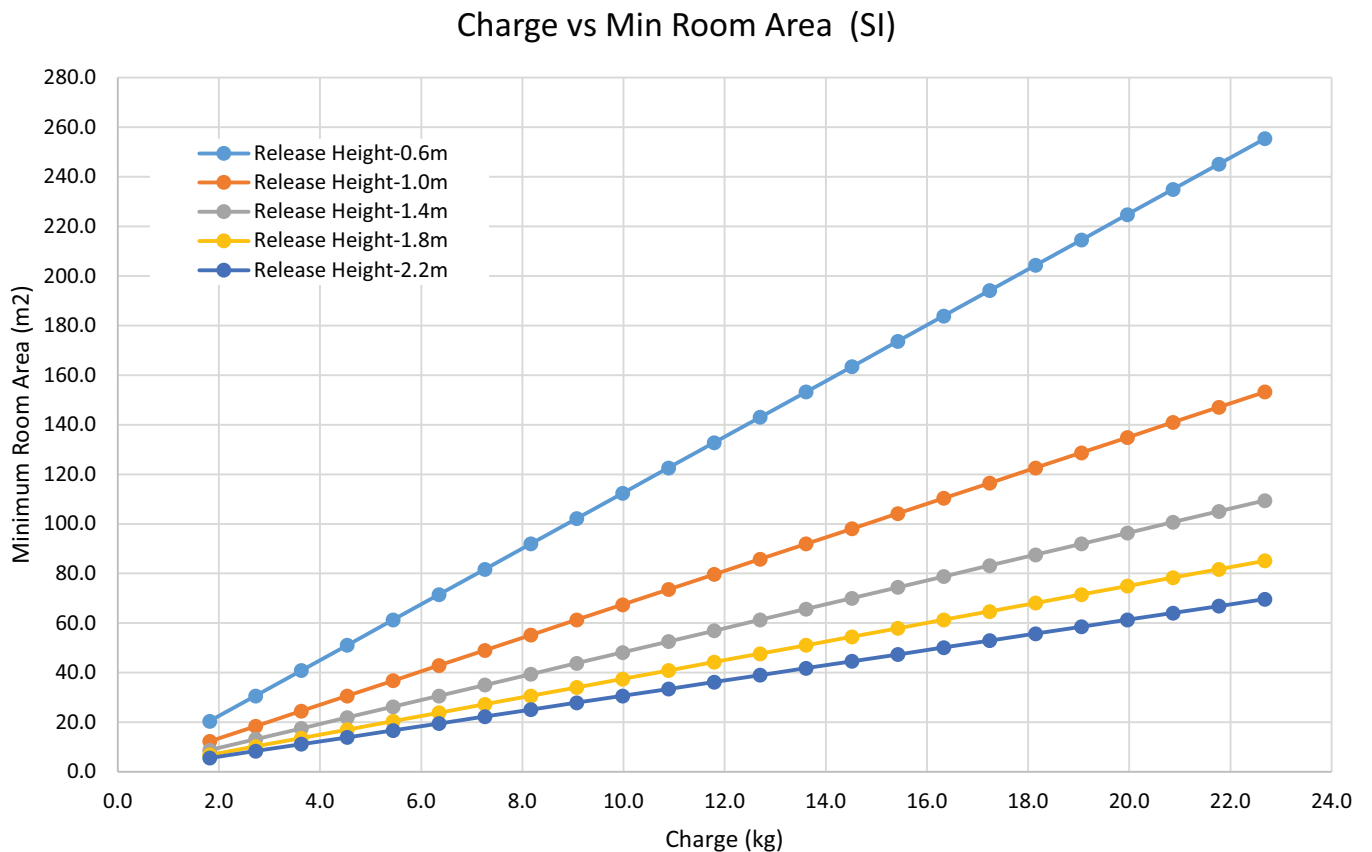
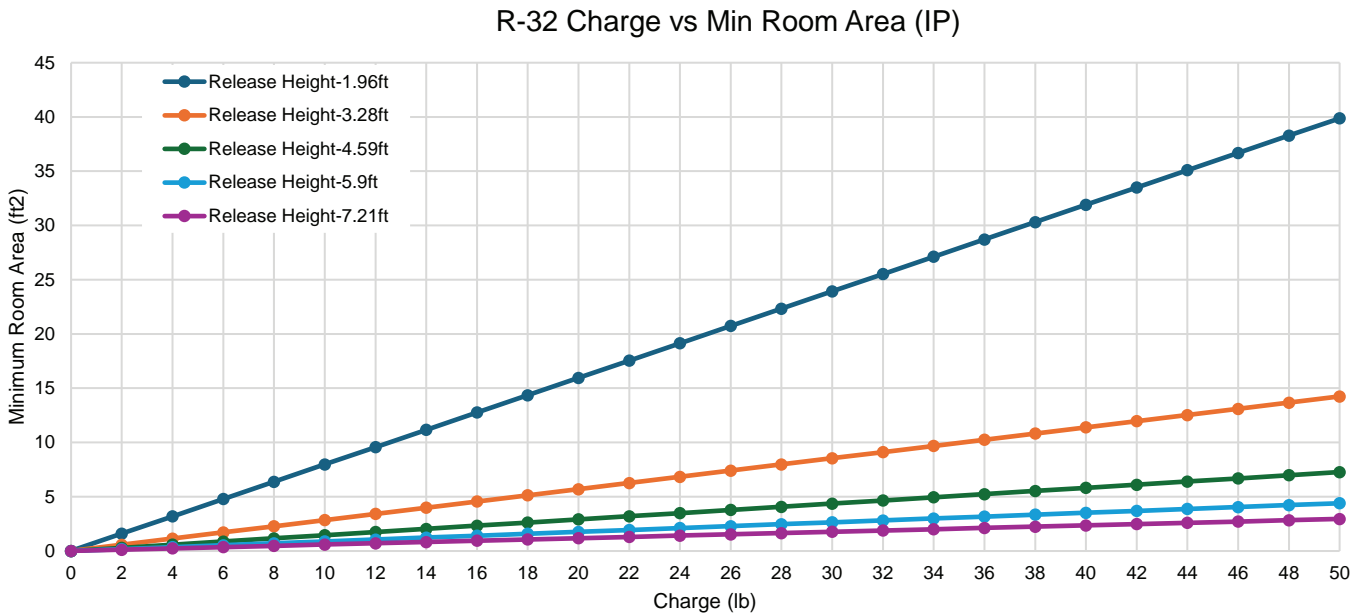


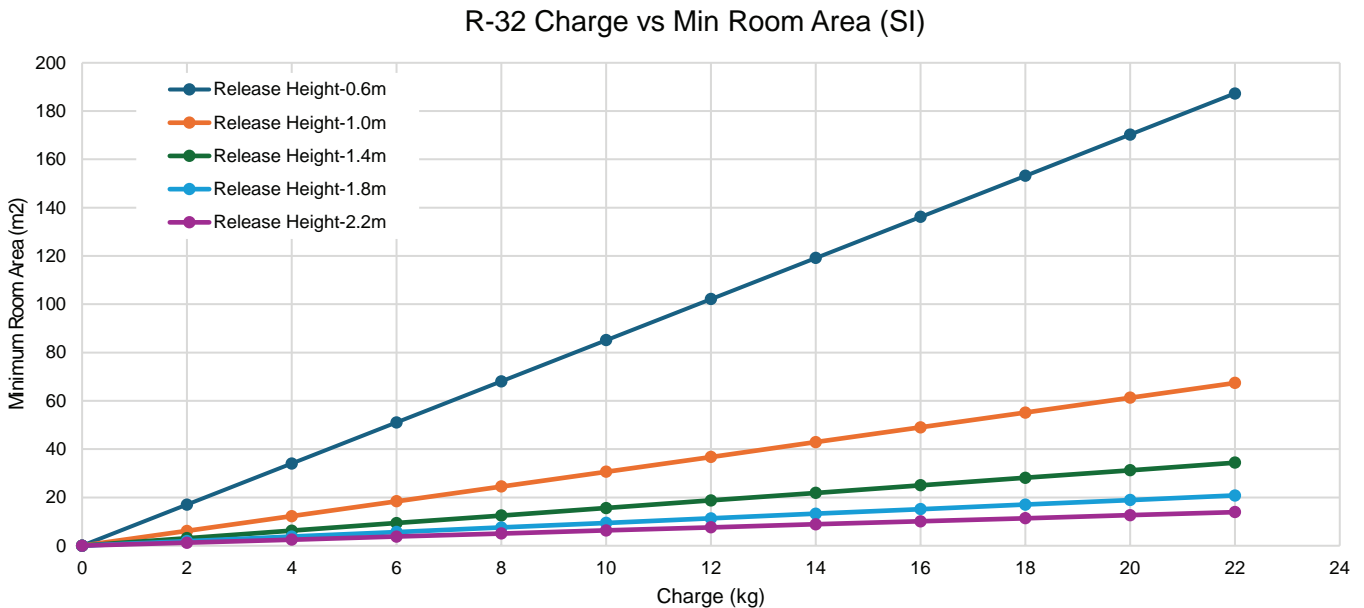
Figure 5. R-454B charge vs min room area (SI)



**Figure 6. R-32 charge vs min room area (IP)**



**Figure 7. R-32 charge vs min room area (SI)**



Release height is the vertical distance from the floor to the lowest point in a space refrigerant would leak from first. The minimum value is 0.6 m from the floor. This point is typically the bottom of free return openings or supply diffusers. For fully ducted units, the release height is 2.2 meters.

$$A_{min.adj} = \text{Nameplate } A_{min} \times \text{Altitude Adj} \times \text{Height Adj} \times F_{occ}$$

Multiply the altitude adjustment factor in the table below by  $A_{min}$  listed on the unit nameplate or in the Installation, Operation, and Maintenance (IOM) manual.

### Minimum Room Area ( $A_{min}$ ) Adjustments

Use equation below to adjust the minimum room area, as applicable, based on the unit's installation height, altitude, and occupancy level it serves.

**Table 7. Altitude adjustment factor**

Altitude (ft)	Sea Level to 2000	2001 to 4000	4001 to 6000	6001 to 8000	8001 to 10000	10001 to 12000	12001 to 14000	14001 to 15000	Over 15000
$A_{min}$ Adjustment	1	1.05	1.11	1.17	1.24	1.32	1.41	1.51	1.57

In addition,  $A_{min}$  can be adjusted if the unit is installed in a room at a height that is higher than the minimum height shown on the unit. To adjust  $A_{min}$ , multiply by the ratio of the unit minimum release height (in meters) / actual release height (in meters). Use 0.6 m in the ratio for unit minimum installation heights less than or equal to 0.6 m.

For institutional occupancies, ASHRAE Standard 15 applies an additional adjustment factor  $F_{occ}$  to the amount of a charge allowed in a space. To calculate the adjusted  $A_{min}$  for institutional occupancies, multiply the  $A_{min}$  on the nameplate by two.

**EXAMPLE 1: 20 Ton Packaged Rooftop Multi-Zone VAV System Serving an Institutional Occupancy Space**

The packaged unit serves 7600 ft.<sup>2</sup> of a nursing home located at an altitude of 4000 ft. The unit has two equally charged 10 ton refrigeration circuits. Each circuit has 12 lbs of refrigerant with a minimum room area requirement of 180 ft.<sup>2</sup> with a 2.2 m release height.

$$TA_{min,adj} = 180 \text{ ft.}^2 \times 1.05 \times 2 = 378 \text{ ft.}^2$$

No additional ventilation is required.

**EXAMPLE 2: 10 Ton Split System Serving a Single Commercial Occupancy Space**

The split system serves a 1500 ft.<sup>2</sup> manufacturing space at 5000 ft. altitude. The final installed charge of the single circuit 10 ton unit is 20 lb. The unit has an open return with a release height of 1 m and ducted supply air. The unit  $A_{min}$  is 660 ft.<sup>2</sup>.

$$A_{min,adj} = 660 \text{ ft.}^2 \times 1.11 = 733 \text{ ft.}^2$$

No additional ventilation is required.

**Determining Room Area (A or TA)**

The room area (A) is the room area enclosed by the projection to the floor of the walls, partitions, and doors of the space that the equipment serves. For ducted systems, total room area (TA) of all rooms connected by ducts, may be used instead of A.

Rooms connected by drop ceilings only are not considered a single room.

Rooms on the same floor of the building, and connected by an open passageway, can be considered part of the same room if the passageway is a permanent opening, extends to the floor and is intended for people to walk through.

Adjacent rooms on the same floor of the building and connected by permanent openings in the walls and/or doors between rooms (including gaps between the wall and

the floor), can be considered part of the same room if the openings meet the following criteria.

- The opening is permanent and cannot be closed.
- Openings extending to the floor, such as door gaps, need to be at least 20 mm above the floor covering surface.
- Natural ventilations opening areas must meet the requirements of ANSIASHRAE Standard 15-2022, Section 7.2.3.2.

Rooms that are connected by a mechanical ventilation system can be considered a single room area if the mechanical ventilation system meets the requirements of ANSIASHRAE Standard 15-2022, Section 7.6.4.

**Leak Detection System (R-454B charge greater than 3.91 lb per circuit or R-32 charge greater than 4.04 lb per circuit)**

The leak detection system consists of one or more refrigerant detection sensors. When the system detects a leak, the following mitigation actions will be initiated until refrigerant has not been detected for at least 5 minutes:

- Energize the supply fan(s) to deliver a required minimum amount of circulation airflow.
- Disable compressor operation.
- Provide an output signal that can be used to fully open zone dampers and/or VAV boxes and disable electric heat in VAV boxes.
- Provide an output signal that can be used to energize additional mechanical ventilation (if needed).
- Units without airflow proving will disable electric heat sources.

Building fire and smoke systems may override this function.

If the refrigerant sensor has a fault, is at the end of its life, or is disconnected, the unit will initiate the mitigation actions. Mitigation actions may be verified by disconnecting the sensor.

The refrigerant sensors do not need service. Use only manufacturer-approved sensors when replacement is required.



## **Field Piping Installation and Charging**

When refrigerant piping is routed indoors, protect from physical damage in operation or service, and verify installation complies with national and local codes. All joints must be accessible for inspection prior to being covered.

Follow the Refrigerant Charging procedure. Prior to refrigerant charging, check field-made indoor joints for leaks using an instrument with a sensitivity of 5 grams per year refrigerant. Pressurize the system to 25% of the maximum allowable pressure. Verify no leaks are detected.

# Installation – Mechanical

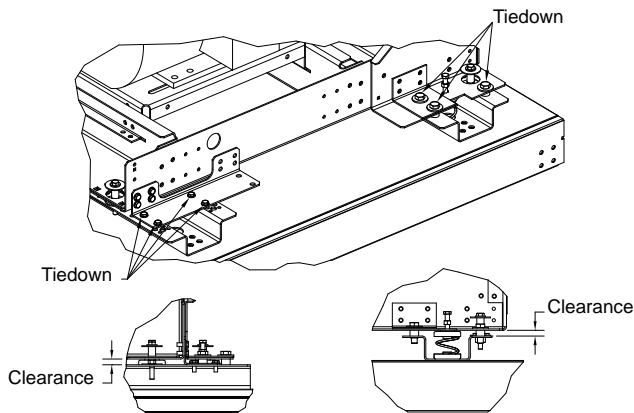
**Important:** Verify installation location meets requirements shown in “[Installation Clearances \(Electric Heat\)](#),” p. 12.

## Lifting and Rigging

### Remove Shipping Tie-Downs

Prior to unit placement, remove the shipping tie-downs.

**Figure 8. Remove shipping tie-downs**



### General Lifting Considerations

#### ⚠ WARNING

##### Heavy Objects!

Placing, assembling, and/or suspending more than one module/subassembly at a time could result in death, serious injury, or equipment damage. Always place, assemble, and suspend modules/subassemblies one at a time.

#### ⚠ WARNING

##### Improper Unit Lift!

Failure to properly lift unit in a LEVEL position could result in unit dropping and possibly crushing operator/technician which could result in death or serious injury, and equipment or property-only damage.

Test lift unit approximately 24 inches (61 cm) to verify proper center of gravity lift point. To avoid dropping of unit, reposition lifting point if unit is not level.

#### NOTICE

##### Equipment Damage!

Premature skid removal could result in equipment damage.

Keep skid in place until unit is ready to set. Do not move the unit or subassembly without the skid in place as shipped from the factory.

Before preparing the unit for lifting, estimate the approximate center of gravity for lifting safety. Because of placement of internal components, the unit weight may be unevenly distributed, with more weight in the coil and fan areas. Approximate unit weights are provided in “[Dimensions and Weights](#),” p. 12. Refer to the unit submittals for actual section weights. Test the unit for proper balance before lifting.

For outdoor air handlers, preparation of the roof curb or pier mount and roof openings must be completed before lifting to the roof.

#### ⚠ WARNING

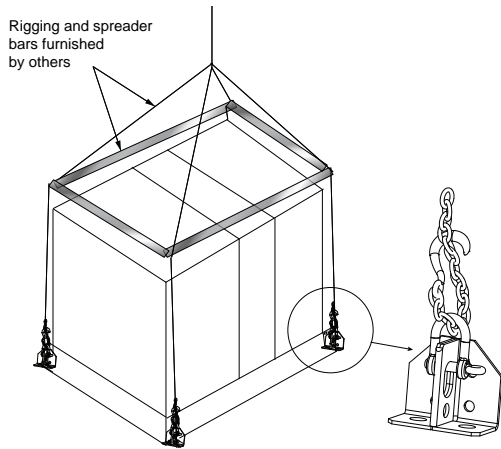
##### Heavy Object!

Failure to follow instructions below could result in unit dropping which could result in death or serious injury, and equipment or property-only damage. Ensure that all the lifting equipment used is properly rated for the weight of the unit being lifted. Each of the cables (chains or slings), hooks, and shackles used to lift the unit must be capable of supporting the entire weight of the unit. Lifting cables (chains or slings) may not be of the same length. Adjust as necessary for even unit lift.

Always rig subassemblies or sections as they ship from the factory. Never bolt sections together before rigging. To assist in proper placement, organize all ship splits in order of configuration before hoisting units in place. See “[Split to Split Orientation Instructions](#),” p. 24.

- Make the loop of the sling parallel to the direction of airflow, if possible.
- When hoisting the unit into position, use the proper rigging method, such as straps, slings, spreader bars, or lifting lugs for protection and safety.
- Use all lifting lugs provided. See submittal documentation for unit lifting lug size. Use field-provided spreader bars and slings to rig units and subassemblies as shown in [Figure 9](#), p. 24. The air handler is not designed to be lifted or rigged from the top of the unit.

**Figure 9. Lifting detail**



- For outdoor units, never stack the pipe cabinet or inlet hood on the unit as it is being lifted.

- Do not attach the intake/exhaust hood or pipe cabinet to the unit prior to lifting the unit. Doing so may damage the equipment. Attach the hoods to the unit only after all sections are in place.
- For outdoor air handlers, all shipping supports and crating on the face of the sections must be removed to permit proper fit-up and sealing of the surfaces. Dispose of properly.

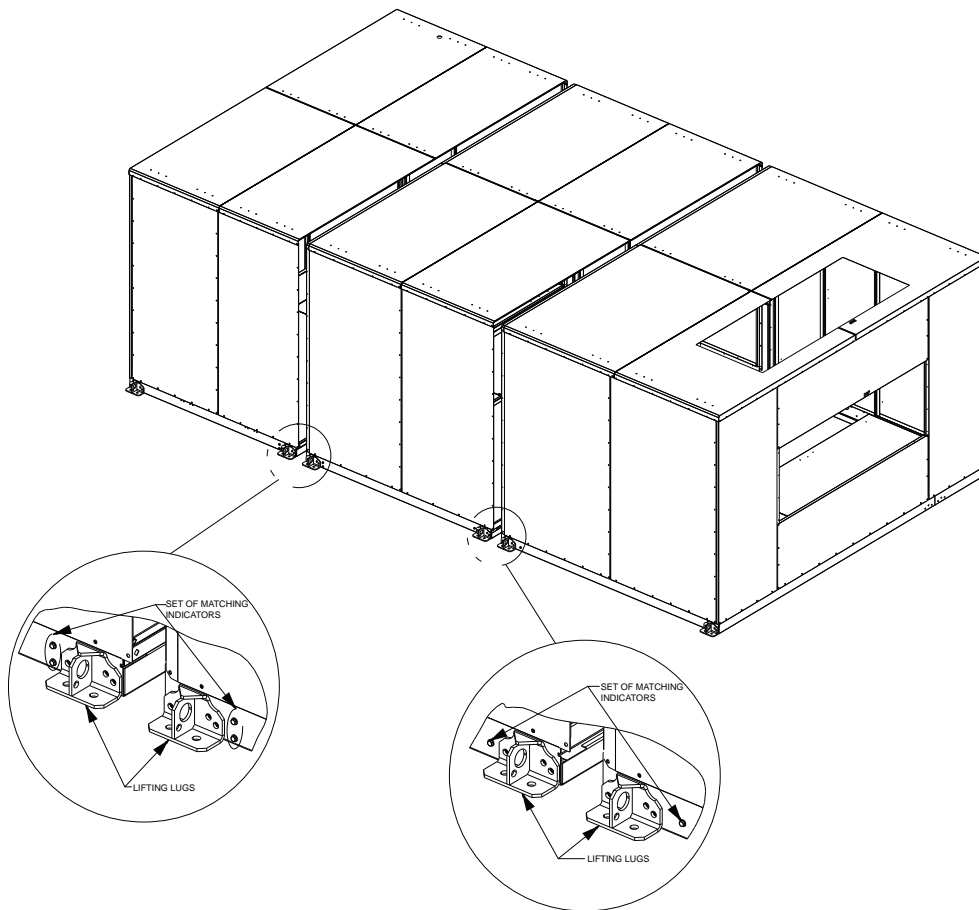
**Split to Split Orientation Instructions**

**Units with Split Indicators on Side Baserails**

Verify each section indicators are on the split side baserails and are aligned with each other. The indicators must have the same orientation and screw quantities.

Example: In the , the split on the left has two screws vertically orientated, while the split on the right has a single screw on each section.

**Figure 10. Units with split indicators on side baserails**

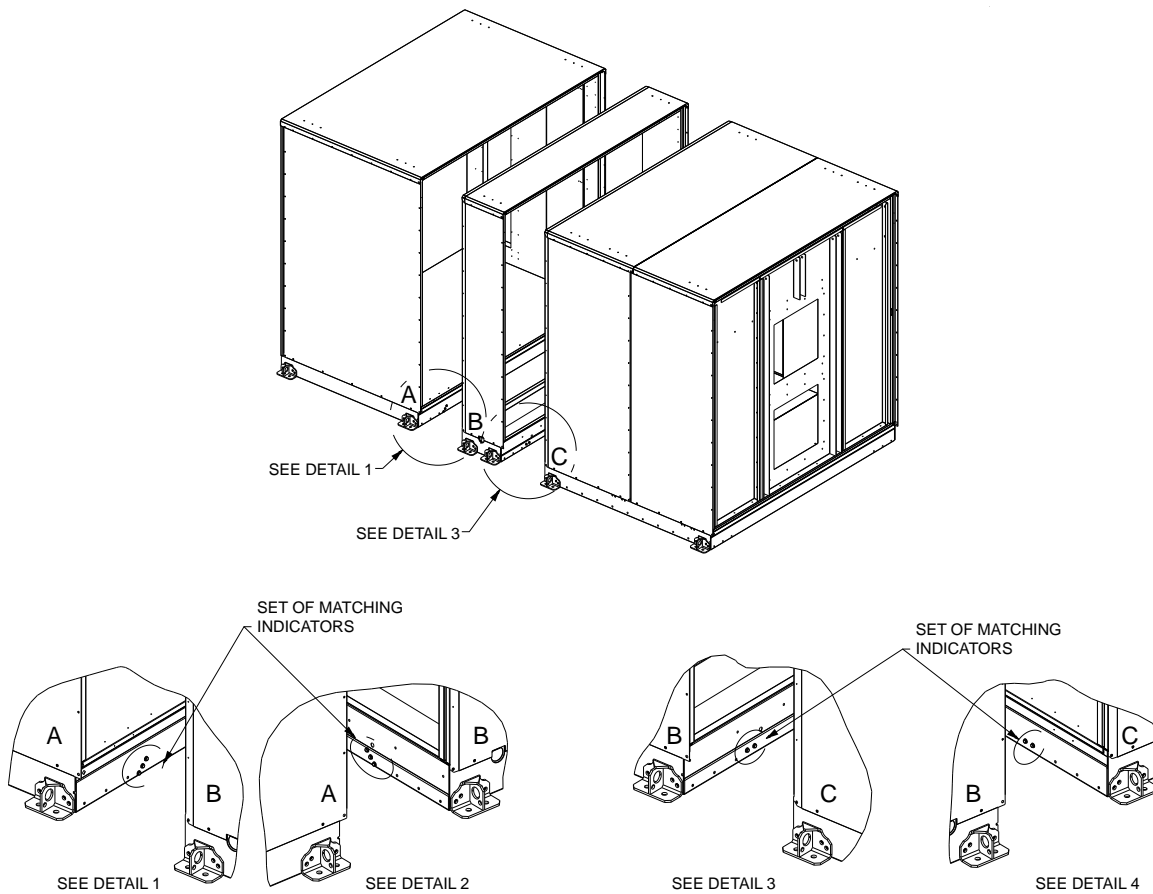


**Units with Split Indicators on Perpendicular Baserails**

Verify each section's indicators are on the split perpendicular baserails and have the same orientation and screw quantities.

Example: In the following figure, split A and B has three screws at a 45 degree angle. Split B and C has two horizontally orientated screws on each section.

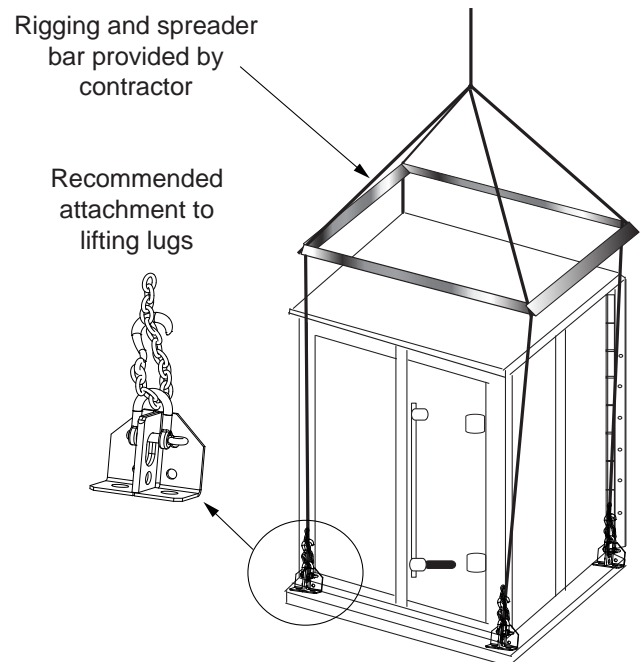
Figure 11. Units with split indicators on perpendicular baserails



### Lifting Hoods and Pipe Cabinets

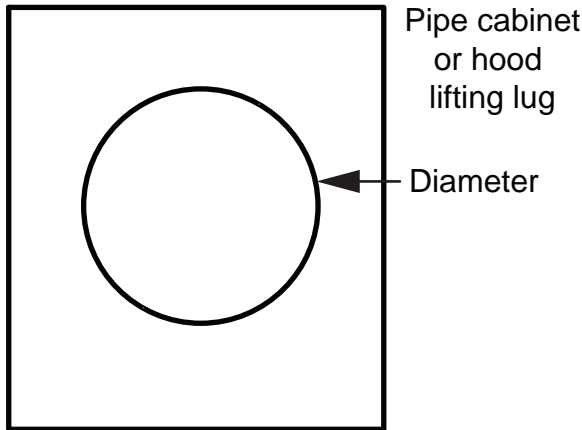
**⚠ WARNING**  
**Heavy Objects!**  
 Placing, assembling, and/or suspending more than one module/subassembly at a time could result in death, serious injury, or equipment damage. Always place, assemble, and suspend modules/subassemblies one at a time.

Figure 12. Lifting pipe cabinets



See [Figure 13, p. 26](#) and [Table 8, p. 26](#) for the pipe cabinet and hood lifting lug dimensions.

**Figure 13. Lifting lug for pipe cabinets and hoods**



**Table 8. Lug hole dimensions for pipe cabinet and hood**

Section	Location	Unit Size	Diameter
Pipe Cabinet	Outdoor	All sizes	2.5-in. diameter
Hood	Outdoor	All sizes	1-in. diameter

**Forklifting Considerations**

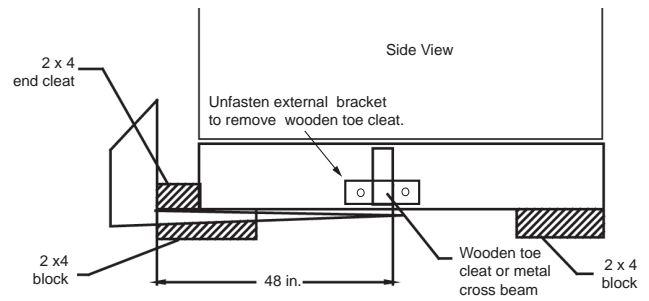
**NOTICE**

**Equipment Damage!**  
 Improper use of fork lift could result in equipment damage.  
 Do not use a fork lift on air handlers or subassemblies that do not have an end cleat. Trane is not responsible for equipment damage resulting from improper fork lift practices.

*Note: Do not use a forklift on outdoor air handlers or indoor air handlers/subassemblies that do not have end cleat (see [Figure 14, p. 26](#)).*

A forklift may be used to lift a single section or small subassembly, provided the forks extend under both ends of the base frame, or as indicated in [Figure 14, p. 26](#). The forks should not contact the bottom of the air handler. Units should only be lifted from the proper end identified by the lifting label on the unit. A lifting crane or other means should be used for larger units where forks cannot extend under both base rails.

**Figure 14. Fork lift points with base rail**



**Unit Placement and Assembly**

If the air handler ships in subassemblies or in individual sections, some assembly is required, including:

- Ceiling-suspended indoor unit assembly; see [“Ceiling Suspension,” p. 28](#).
- Section-to-section assembly; see [“Section-to-Section Assembly,” p. 29](#).

**⚠ WARNING**

**Toxic Fumes!**  
 Failure to follow instructions below could produce toxic gas which could result in death or serious injury. Keep open flame away from unit exterior or interior. Do not weld or use cutting torch on the exterior or interior. The unit contains polyurethan insulation. Flames could produce toxic gas.

**NOTICE**

**Equipment Damage!**  
 Failure to follow instructions below could result in equipment damage.  
 Do not exceed the following operating temperature limits in internal unit sections:

- Sections with electrical components: 104°F
- Sections without electrical components: 200°F

**⚠ WARNING**

**Heavy Objects!**  
 Placing, assembling, and/or suspending more than one module/subassembly at a time could result in death, serious injury, or equipment damage. Always place, assemble, and suspend modules/subassemblies one at a time.

**NOTICE**

**Microbial Growth!**

Failure to follow instructions below could result in odors and damage to the equipment and building materials.

The floor or foundation must be level and the condensate drain at the proper height for proper drainage and condensate flow. Standing water and wet surfaces inside the equipment can become an amplification site for microbial growth (mold). If there is evidence of microbial growth on the interior insulation, it should be removed and replaced prior to operating the system.

If a unit arrives in sections, then each section must be individually hoisted, set on the housekeeping pad, roof curb, or pier mount and then assembled.

Refer to the unit submittals and unit tagging for correct placement of all sections. If there are any discrepancies between the submittals and the unit tagging, contact your local Trane representative before proceeding.

Following the order of the sections on the unit submittals and tagging, individually place each unassembled section or subassembly in the appropriate installation location.

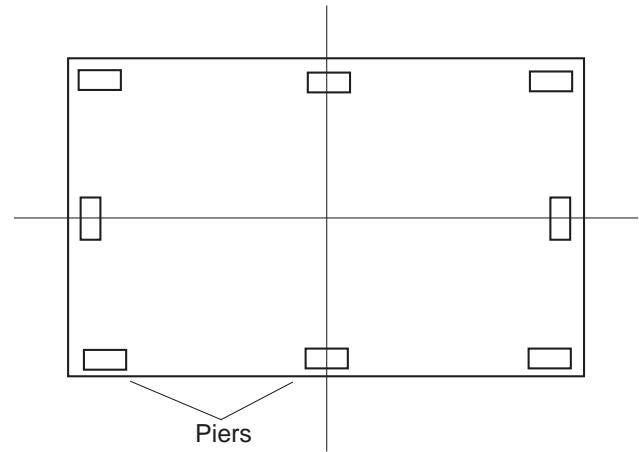
**Note:** Prior to placing fan section in the appropriate installation location, verify shipping tie-downs have been removed.

For outdoor units, the pipe cabinet must also be mounted as an individual section. Refer to “Pipe Cabinet Installation,” p. 35 for specific instructions.

When mounting the unit on a roof curb, make sure the gasketing between the roof curb and unit base provides an airtight seal.

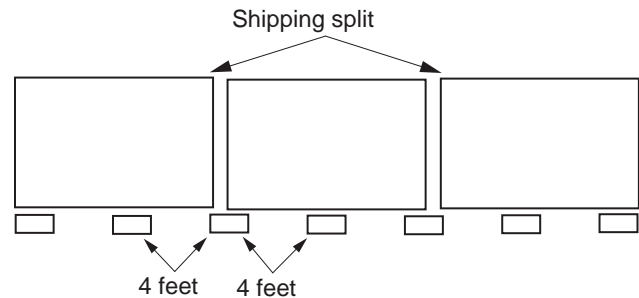
When mounting the unit on a pier mount, locate one pier at each corner as a minimum, directly underneath any shipping split (ensure full support under each side) and then every four feet at equally spaced intervals around the perimeter of the unit. Both the unit and the pipe cabinet should be supported by their base around the entire perimeter. See Figure 15, p. 27 and Figure 16, p. 27.

Figure 15. Piers located in each corner and spaced evenly every four feet



**Note:** Piers beneath shipping splits must be structurally sound to support the weight of the unit.

Figure 16. Side view with two shipping splits - locate one pier directly under each shipping split



**Note:** Piers beneath shipping splits must be structurally sound to support the weight of the unit.

For proper operation, the unit must be installed level (zero tolerance) in both horizontal axes. For vertical discharge units, allow space under the unit for supply air ductwork connections.

**Note:** Air handlers often include optional factory-provided casing penetration entry points for field-provided wiring. Consider overall unit serviceability and accessibility before mounting, running wires (power), making cabinet penetrations, or mounting any components to the cabinet.

See “Component Installation,” p. 52 for special assembly/ installation considerations.

**Removing the Shipping Skid**

Remove the wooden shipping blocks, wooden toe cleat if there is one, and end cleats prior to lowering unit into final position or installing the unit to the roof curb.

## Ceiling Suspension

### ⚠ WARNING

#### Risk of Unit Dropping!

Improper use of the mounting legs as described could result in unit dropping and crushing technicians which could result in death or serious injury, and equipment damage.

Do not use mounting legs for ceiling suspension, external isolation, or unit support during module placement. Mounting legs are designed only to secure the unit to the floor, housekeeping pad, or platform.

**Note:** Ceiling suspension is not recommended for units larger than 28,000 CFM unless using a field-provided mounting frame.

### Using a Field-Provided Mounting Frame

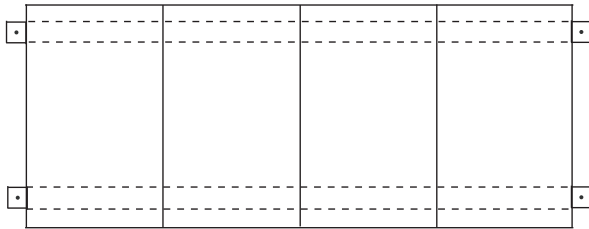
If a field-provided mounting frame is used for ceiling suspension, the installer/contractor must provide a ceiling-suspended mounting frame designed to support the length, width, and weight of the entire air-handling unit. See “Dimensions and Weights,” p. 12 for approximate weights.

**Note:** It is the building engineer’s responsibility to size the structural channels and to provide the appropriate hangers.

Structural channels in a field-provided frame can be mounted parallel to airflow or perpendicular to airflow:

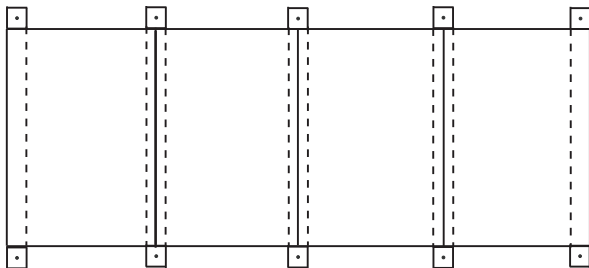
- For parallel-to-airflow channels, size channels based on a four-point load distribution (see Figure 17, p. 28).

**Figure 17. Typical suspension method-parallel channels**



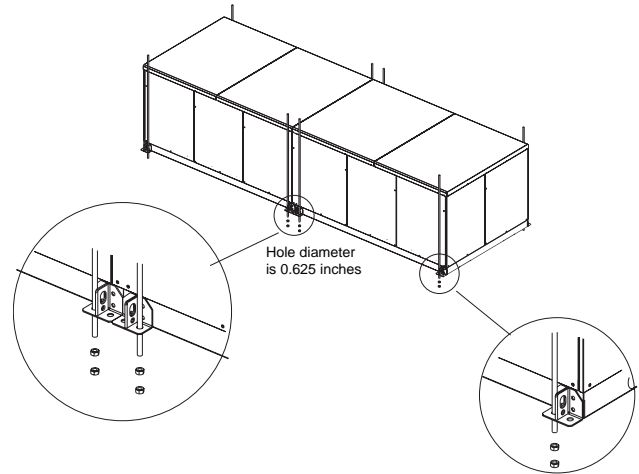
- For perpendicular-to-airflow channels, size channels based on the load distribution of the individual sections and install the channels so that both ends of every section are supported (see Figure 18, p. 28).

**Figure 18. Typical ceiling suspension-perpendicular channels**



## Using Integral Base Frame

**Figure 19. Ceiling suspension for unit sizes for up to 28,000 cfm**



If using the factory-provided integral base frame for ceiling suspension, individual sections and/or subassemblies will have base frame shipping splits and base frame lifting lugs. When using the base frame for ceiling suspension:

- Suspend the unit (on both sides of the unit) at each shipping split lug as well as the four corners of the unit (see Figure 19, p. 28). See submittal documentation for unit lifting lug size.
- Bolt shipping splits together.

The hanger rods must extend through the bottom of the base lug. It is the building engineer’s responsibility to provide the appropriate hangers.

## Shipping Gussets

Prior to pulling the shipping splits together, the shipping gussets (see Figure 20, p. 29) should be removed to simplify panel removal (except for hurricane units or units that require OSHPD certification). If there is enough access after joining the shipping splits, the gussets can be removed after they are joined. The exception to this rule is for stacked units where the first level is greater than 65 inches external height. For these units, the gussets should be left in place for the lower level unit unless they are installed in a shipping split that contains a coil. The other exception is when access to install or change out front-loaded filters is restricted or blocked.

**Figure 20. Shipping gusset**



Do not mistake the coil structural gusset (see [Figure 21, p. 29](#)) used on larger units with the shipping gussets.

**Figure 21. Coil structural gusset**



### Section-to-Section Assembly

Air handlers ship with all necessary assembly hardware and gasket material. The hardware should be packaged in either a clear plastic envelope or cardboard box inside the fan section, access section, or mixing box.

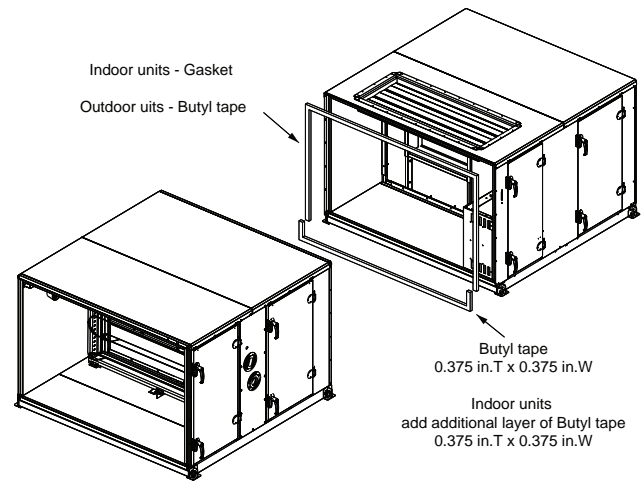
The number of sections to be assembled often makes it necessary to use more than one section to ship the assembly material; therefore, check all sections thoroughly before contacting your Trane sales representative to report missing items.

Sections are joined with gasketing applied to one of the mating surfaces and hardware to bolt the sections together. The gasketing for section-to-section joints is a closed cell foam with adhesive backing.

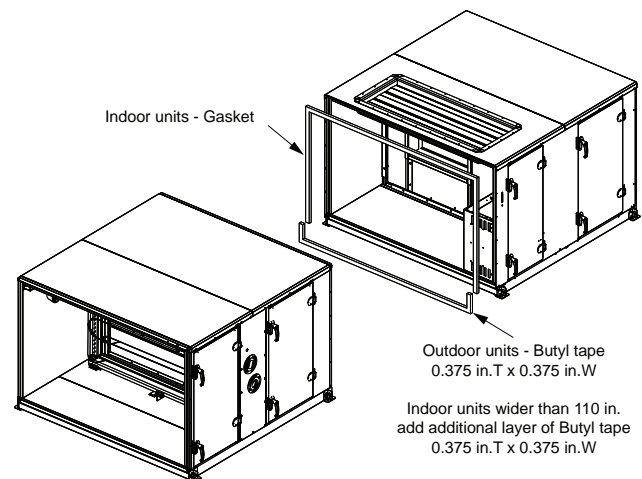
To assemble the unit:

1. Locate the mounting hardware and gasket material.
2. All shipping supports and crating on the face of the sections must be removed and discarded to permit proper fit-up and sealing of the surfaces. Remove any shipping bolts located on the mounting surfaces of the sections (see [Figure 22, p. 29](#)).
3. Apply the gasketing to one of the mating surfaces; see [Figure 22, p. 29](#), [Figure 23, p. 29](#), and [Figure 27, p. 30](#).

**Figure 22. Section-to-section installation**



**Figure 23. Coil section-to-downstream section bolt up with splash guard**



**Note:** Gasket/Butyl tape should be on outermost edge of panel. See installation in [Figure 24, p. 29](#), [Figure 25, p. 30](#), and [Figure 26, p. 30](#).

**Figure 24. Install Butyl tape to outermost edge of panel**

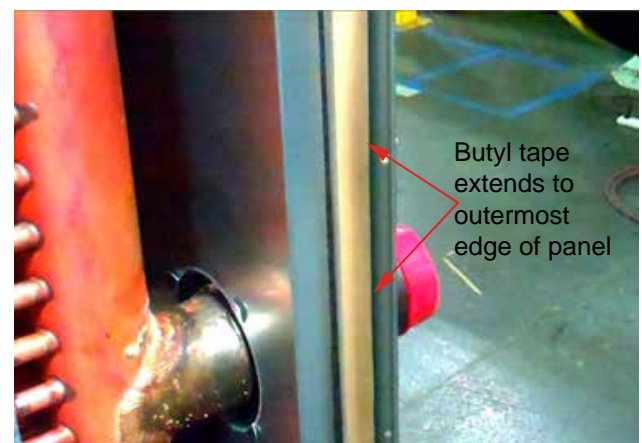


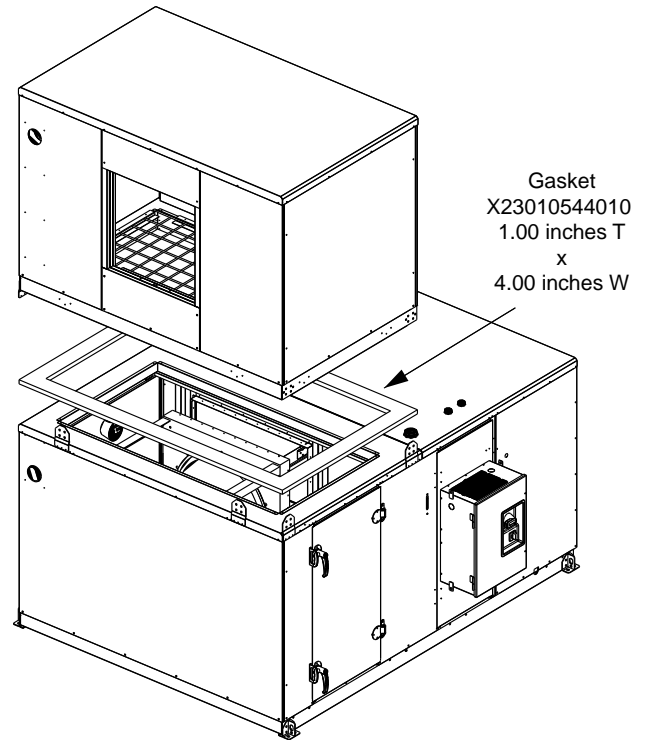
Figure 25. Install gasket to outermost edge of panel



Figure 26. Install outdoor Butyl tape to outermost edge of panel



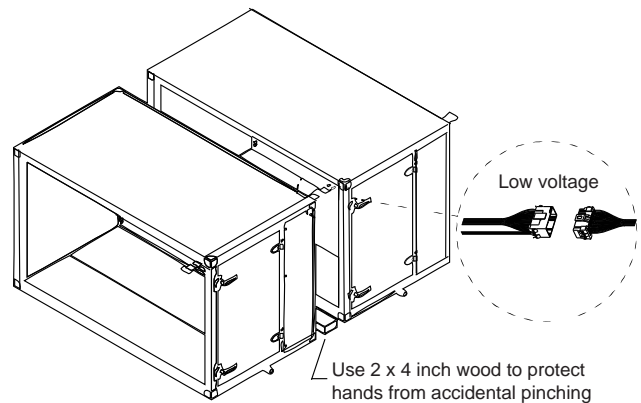
Figure 27. Stacked unit assembly



- If the unit is equipped with factory-mounted controls, move adjacent subassembly within six inches and fasten quick connects where the sections bolt together. See Figure 28, p. 30 for low voltage. See Figure 29, p. 31 and Figure 30, p. 31 for high voltage.

**Note:** Reference the appropriate controller manual for more details on the installation of units with factory-mounted controls.

Figure 28. Horizontal section-to-section low voltage quick connects

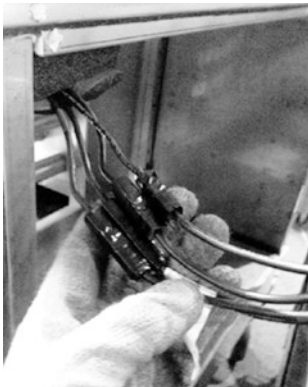


**Figure 29. Horizontal section-to-section high voltage quick connects**



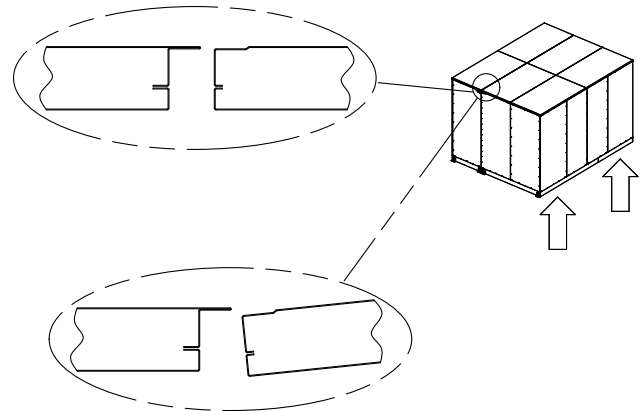
5. Assemble and seat connections per color code.

**Figure 30. Horizontal section-to-section high voltage quick connects**



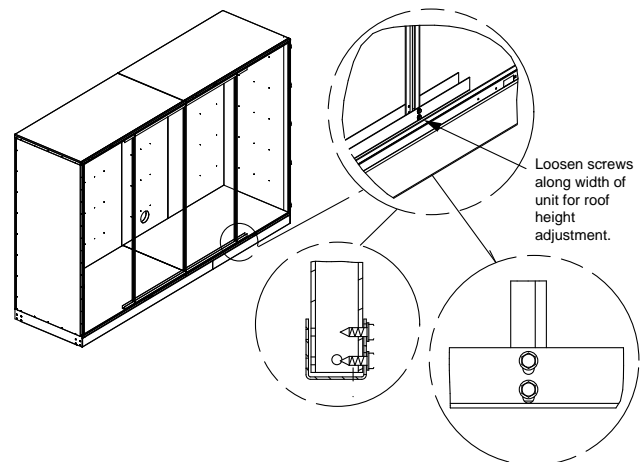
6. Wrap each connection individually with black electrical tape.
7. Fully wrap the connection with tape.
8. Use a bar clamp to pull adjacent shipping section lifting lugs together.
9. For larger indoor and outdoor units, a wedge block is provided to aid in pulling and aligning the units together. Attach the wedge blocks to both sides of the units being pulled together, matching the correct wedge block with the correct hole pattern. See [Figure 34, p. 33](#).
10. Verify that the subassembly with the overhang profile on the roof is higher than the mating subassembly. If it is not, raise one end of the subassembly and bring the unit together. See [Figure 31, p. 31](#).
11. Due to unlevelled floor and platforms, the roof may be misaligned as shown in [Figure 31, p. 31](#). A common solution is to raise one end of the shipping section to clear the hemming before pulling the units together.

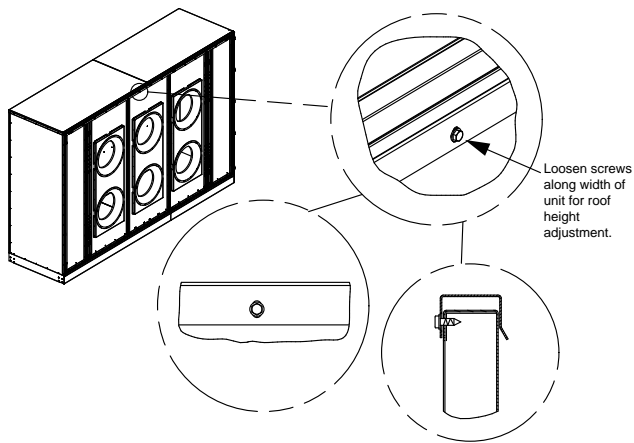
**Figure 31. Roof alignment (indoor unit only)**



12. In addition, an adjustment can also be made to the height of the roof of either subassembly. At the center (widthwise) of the unit, measure the height of each adjacent subassembly and verify that the subassembly with the overlap sheet metal is higher than the mating subassembly roof. If it is not, adjust the height of either subassembly by loosening the screws in the vertical channels or component structure and adjust the height of the roof. See [Figure 32, p. 31](#) and [Figure 33, p. 32](#).

**Figure 32. Adjust height of roof by adjusting vertical channels**

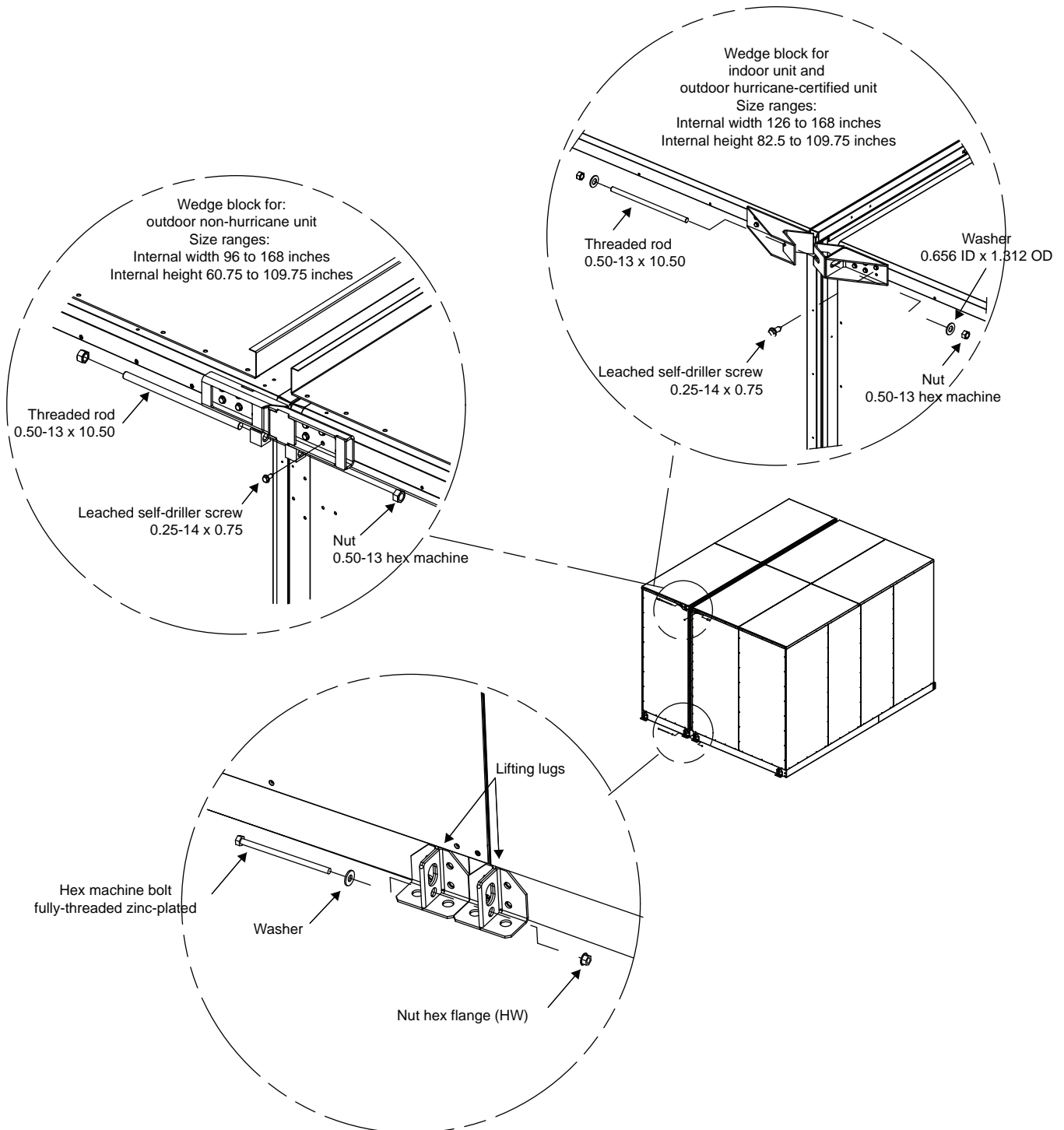


**Figure 33. Adjust height of roof by loosening screws**

13. Bolt the unit base frames together using bolts or threaded rod provided (see [Figure 34, p. 33](#)).
14. Use straps and come alongs to compress the gasketing and pull the sections together along the height of the unit.

**Note:** *Wedge blocks are used to assemble shipping splits together. Only one set of wedge blocks is shipped with each unit. Once the shipping split has been assembled, remove the wedge blocks and use for the next shipping split.*

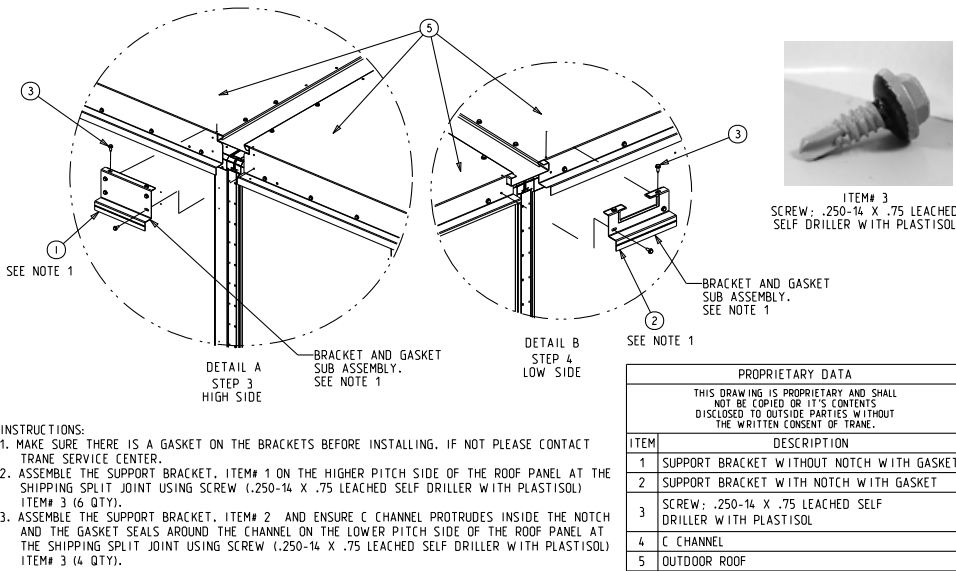
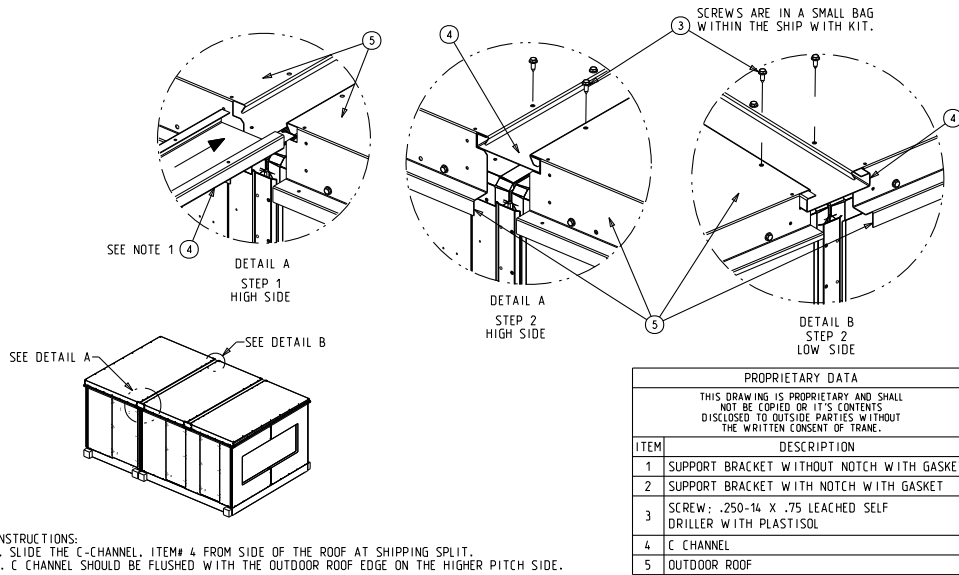
Figure 34. Shipping split assembly



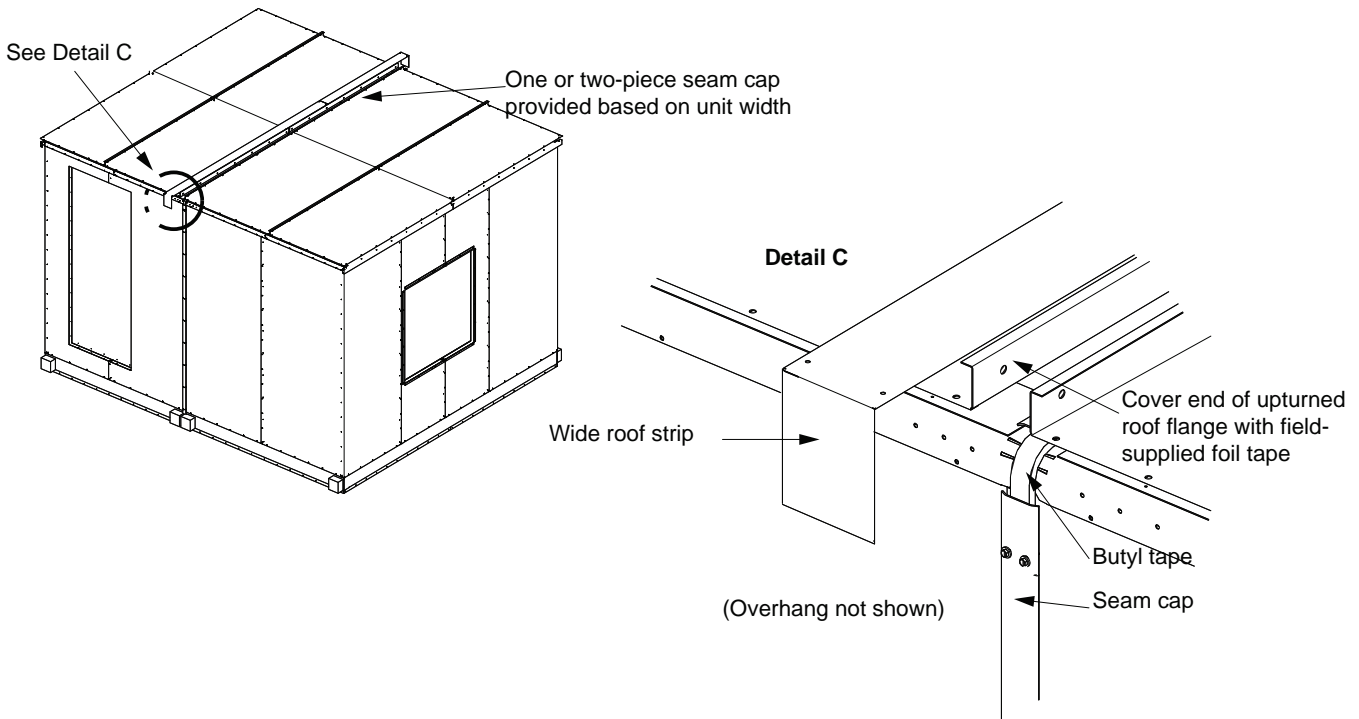
15. Install the section-to-section screws inserting the appropriate screws through the overlapping flanges using a powered impact gun and taking care not to strip the screws. Outdoor air handlers will ship with seam cap that is to be installed over the section-to-section

seams. Factory-supplied butyl tape must be continuously applied over the top and both side seams prior to seam caps being applied. See [Figure 35, p. 34](#) and [Figure 36, p. 35](#).

**Figure 35. Section-to-section seam cap installation for non-hurricane units (internal widths 27.5 to 96 in.)**



**Figure 36. Section-to-section seam cap installation (internal widths 102 to 168 in.)**



16. For outdoor units, a wide roof strip is provided. Apply aluminum tape to block off open cavity beneath the overhang angle and roof strip on both sides of unit at the shipping split to prevent unwanted pests from entering.

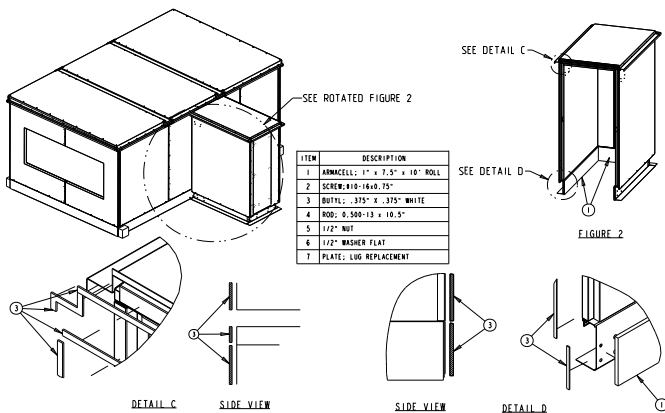
base member on pipe cabinet base by removing the four bolts and nuts.

2. Add 1-inch × 7.5-inch Armacell® gasketing to inside of base rail and add 3/8-inch × 3/8-inch white Butyl® tape to face of pipe cabinet. See [Figure 37, p. 35](#) and [Figure 38, p. 36](#).

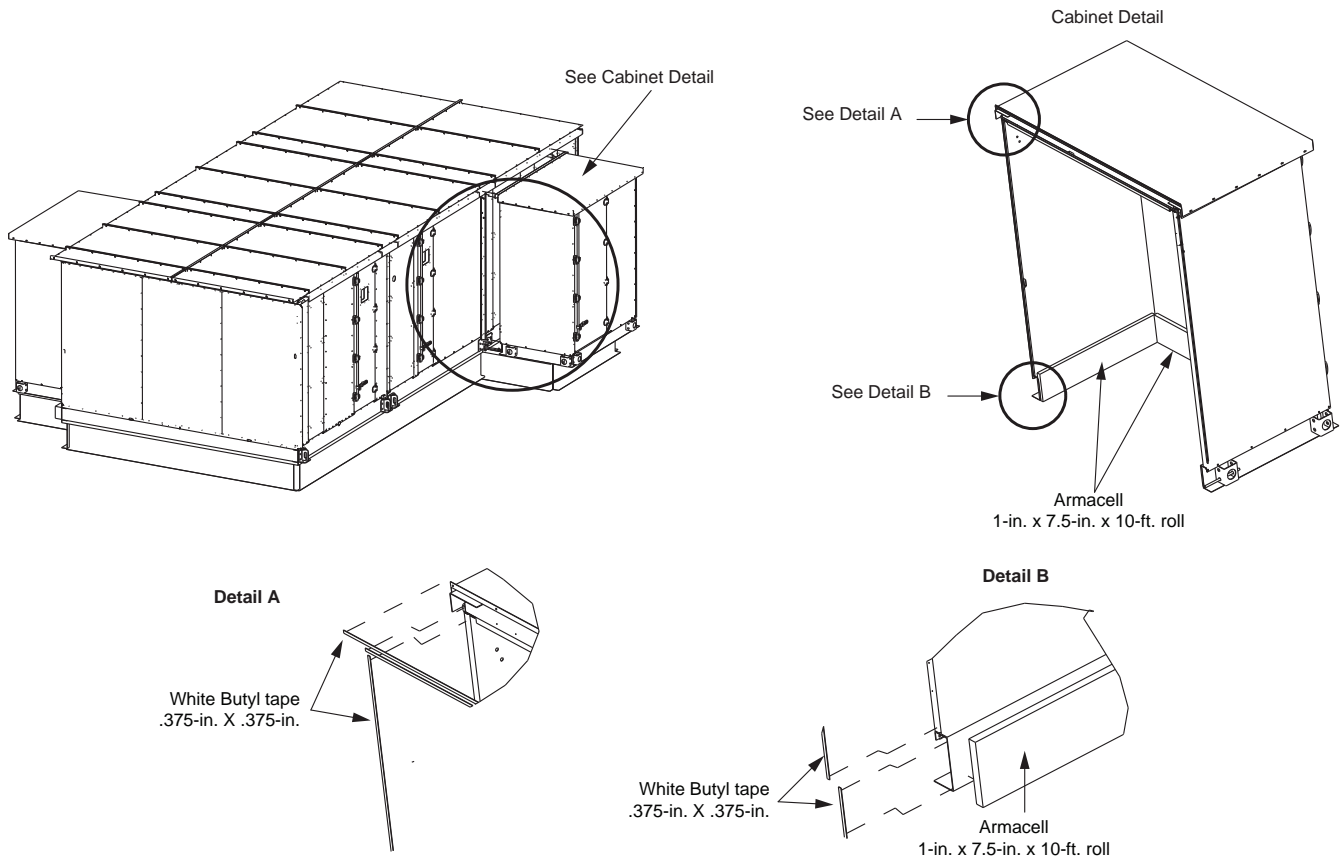
### Pipe Cabinet Installation

1. After air handler is completely installed and checked to ensure that the unit is level and square, remove cross

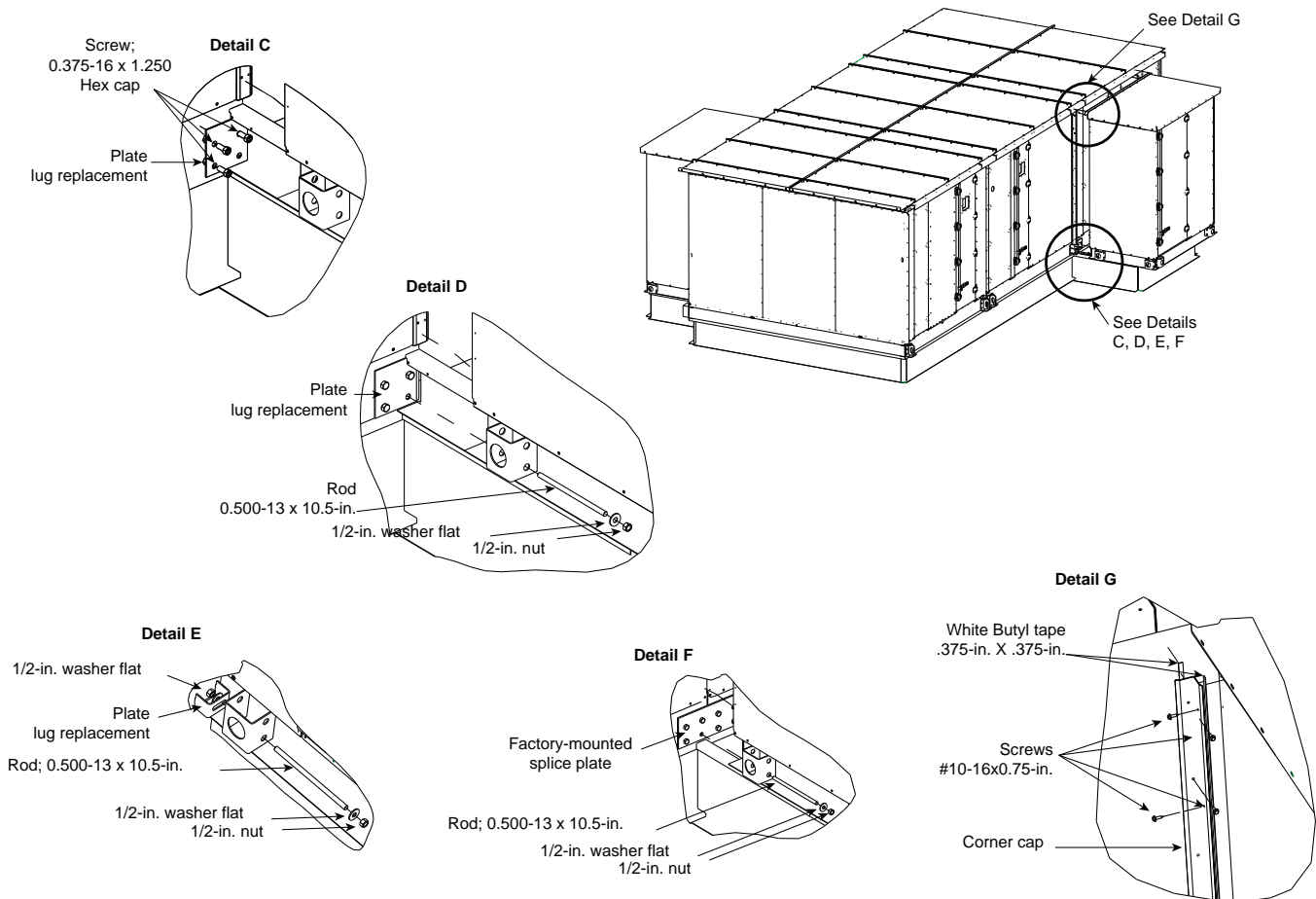
**Figure 37. Pipe cabinet installation, unit internal widths 27.5 to 96 in.**



**Figure 38. Pipe cabinet installation (internal width 102 to 168 in.)**



1. Install inside corner cap. See [Figure 39, p. 37](#) Detail A and Detail B.
2. Install 3/8-inch × 3/8 inch white Butyl tape to unit wall where pipe cabinet roof connects.
3. Lift pipe cabinet roof into place and attach to unit wall with screws. See [Figure 39, p. 37](#).

**Figure 39. Pipe cabinet installation details**


### Pipe Cabinet to be Installed at Shipping Split Joint

1. Remove threaded rod and unit lug that is outside of pipe cabinet.
2. Using three screws from unit lug, install black lug replacement plate in place of unit lug. See [Figure 39, p. 37](#) Detail C.
3. Lift pipe cabinet into place on roof curb.
4. Slide pipe cabinet into place.
5. Put threaded rod through pipe cabinet lifting lug into weld nut inside base rail to pull the pipe cabinet tight against the unit. See [Figure 39, p. 37](#) Detail D.

### Pipe Cabinet to be Attached to Unit Base Bracket

1. Lift pipe cabinet into place on roof curb.
2. Slide pipe cabinet into place.
3. Put threaded rod through pipe cabinet lifting lug into welded unit base rail bracket to pull the pipe cabinet tight against the unit. See [Figure 39, p. 37](#) Detail E.

### Pipe Cabinet to be installed at a Factory Joint

1. Lift pipe cabinet into place on roof curb.
2. Slide pipe cabinet into place.
3. Put threaded rod through pipe cabinet lifting lug into weld nut inside base rail to pull the pipe cabinet tight against the unit. See [Figure 39, p. 37](#) Detail F.

#### Completing Pipe Cabinet Installation

1. Install inside corner cap. See [Figure 39, p. 37](#).
2. Install 3/8-in. white Butyl tape to unit wall where pipe cabinet roof connects.
3. Lift pipe cabinet roof into place and attach to unit wall with screws. See [Figure 39, p. 37](#).

### Hood Installation

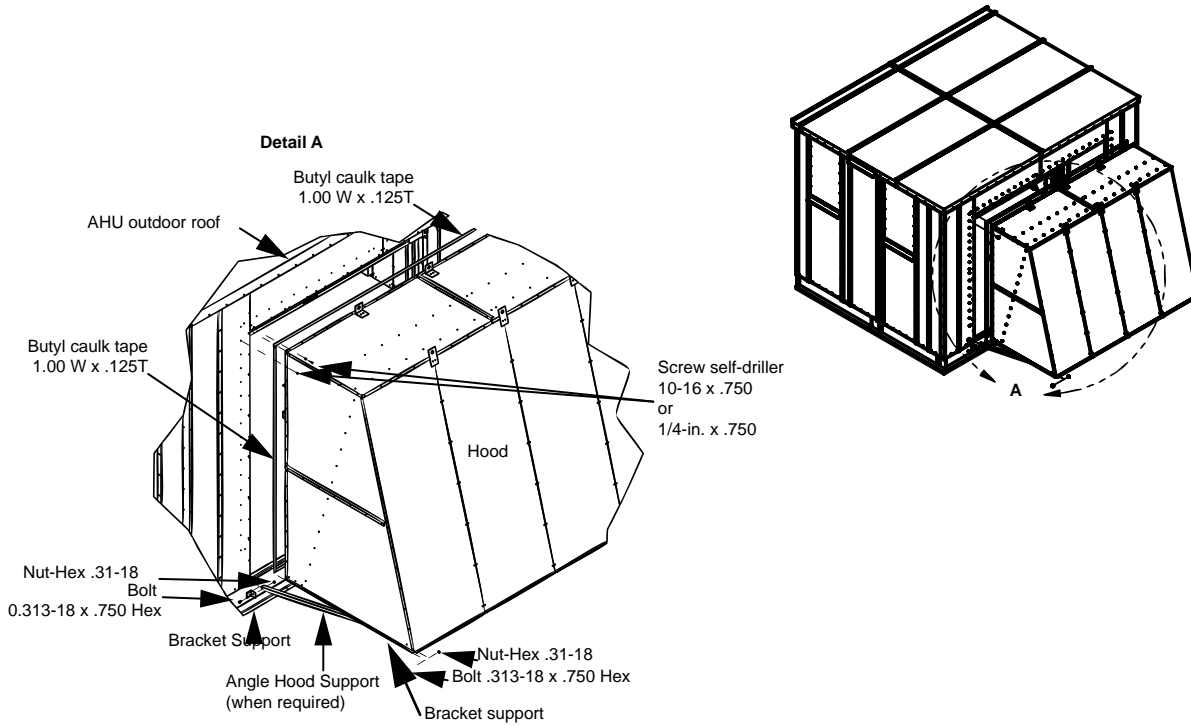
1. Per the unit drawing determine mounting location of the unit weather hoods.
2. Using the factory provided screws mount the weather hoods to the unit.
3. On larger units, weather inlet hurricane and exhaust hoods may be large enough to require angled down supports. In those cases, the angles are shipped

## Installation – Mechanical

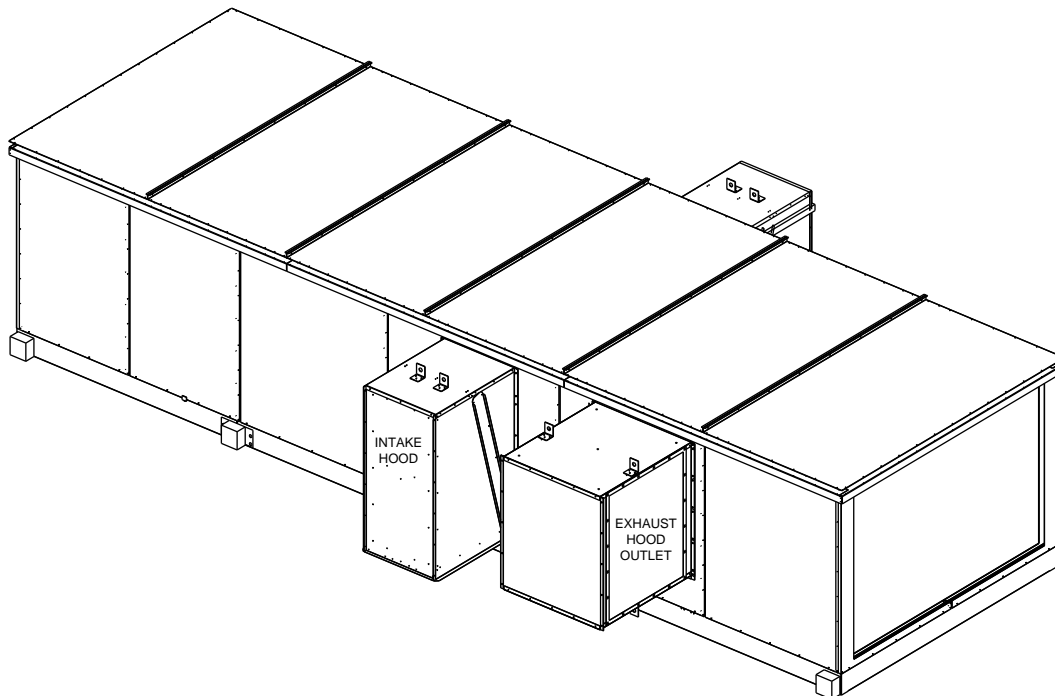
attached to the hood but will need to be connected to the air handler by the installing contractor. See [Figure 40, p. 38](#).

**Note:** It is required that the hoods be sealed to the unit using factory-provided butyl/caulk tape.

**Figure 40. Inlet hurricane and exhaust hood installation**



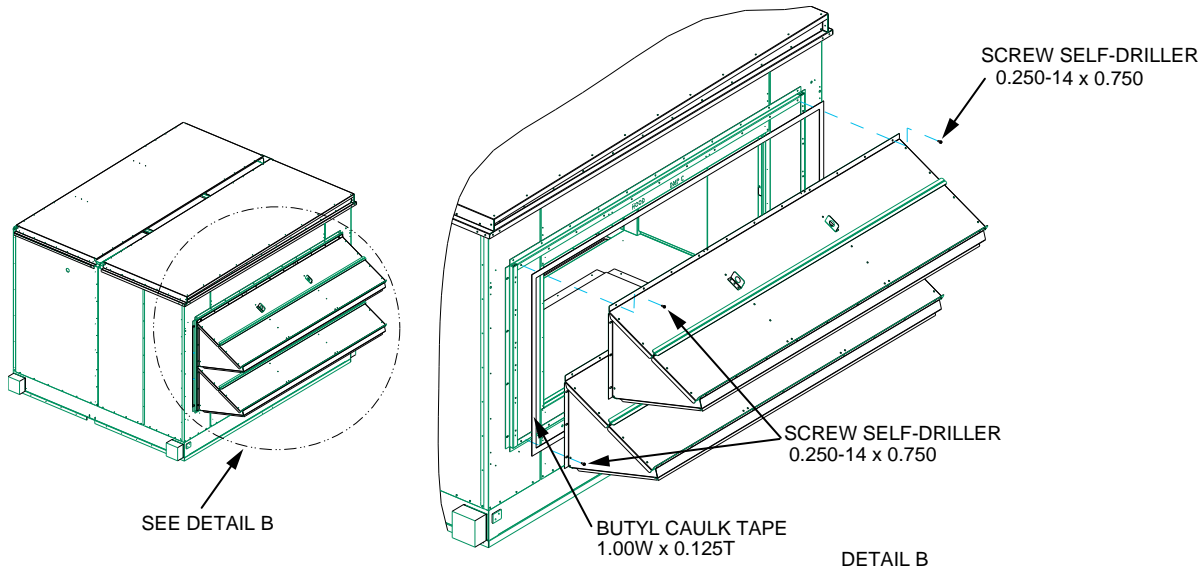
**Figure 41. Fan section side discharge exhaust hood installation (intake hood shape varies)**



4. Install Exhaust Hood such that it discharges away from any adjacent intake hoods. Exhaust discharge location can be changed on installation by rotating the hood.

5. Units with multiple standard inlet hoods require that the hoods be installed from bottom to top. Overlap locations should be sealed with butyl caulk between the hoods. See [Figure 42, p. 39](#).

**Figure 42. Standard inlet hood installation**



## Stacked Outdoor Unit Assembly

### Assembly Hardware

**Table 9. Parts list for outdoor stacked units**

Item	Description
1	Gasket: 1.00T x 4.00W
2	Bracket: Stacked unit
3	Screw: 0.313-18 x 0.875 sheet metal
4	Screw: 10-16 x 0.750 self driller
5	Tape: Butyl 0.38T
6	Tape: Ribbed Butyl
7	Plate: Vertical seam cap
8	Tape: 0.12T x 1.00W, gray Butyl
9	Guard: perpendicular to airflow flashing
12	Guard: Direction of airflow flashing
13	Guard: Flashing seam cover
14	Adhesive/sealant: Flex polyurethane
15	Bracket: Hood support

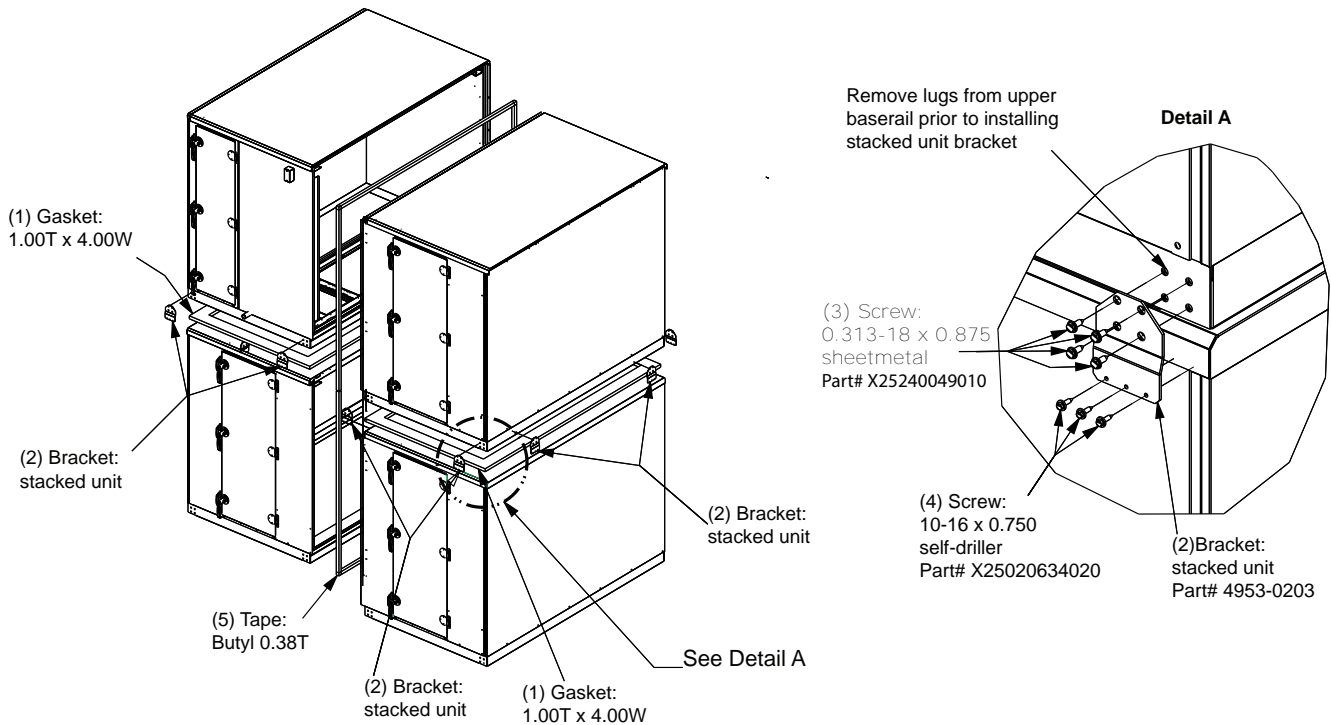
**Table 9. Parts list for outdoor stacked units (continued)**

Item	Description
16	Angle: Hood support
17	Screw: 0.250-14 x 0.750 self driller

### Unit Assembly

1. See [Figure 43, p. 40](#). Apply gasket (Item 1) on top of lower unit. Compress gasketing to ensure a good air seal between upper and lower sections.
2. Place upper unit on lower unit.
3. Remove lifting lugs from top unit and attach stacking brackets (Item 2) to top and bottom units using screws (Item 3 and Item 4). See [Detail A in Figure 43, p. 40](#). Stacking brackets (Item 2) are to be used on the right and left sides at each shipping split section end and also on front and back of the unit.
4. Apply Butyl tape (Item 5) to one side of the shipping split section.
5. Slide shipping split sections together, pulling tight using lifting lugs and threaded rod on bottom and straps or pipe clamps on top.

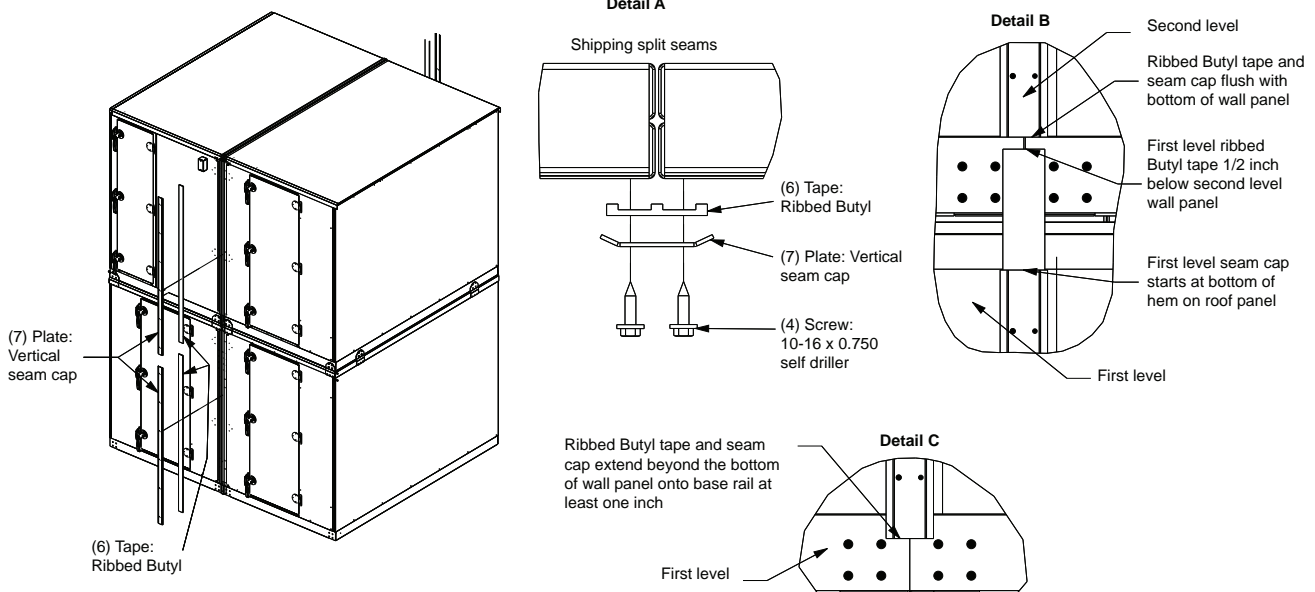
Figure 43. Stacked unit assembly



### Vertical Seam Cap Installation

- See [Figure 44, p. 41](#). Apply ribbed Butyl tape (Item 6) over all vertical shipping split seams (see [Detail A](#)). First level ribbed Butyl tape (Item 6) starts 1/2 inch below second level wall panel (see [Detail B](#)), and extends down beyond the bottom of the first level wall panel onto the base rail at least one inch (see [Detail C](#)). Second level ribbed Butyl tape (Item 6) starts at bottom of wall panel on second level (see [Detail B](#)) and runs up to the top of the second level wall panel.
- Secure vertical seam cap (Item 7) over ribbed Butyl tape (Item 6) with screws (Item 4) (see [Detail A](#)). First level vertical seam cap (Item 7) starts at bottom of hem on roof panels (see [Detail B](#)) and extends down onto the base rail at least one inch (see [Detail D](#) in [Figure 48, p. 43](#)). Vertical seam cap (Item 7) on second level starts at bottom of wall panel and extends up (see [Detail B](#)). Second level vertical seam cap (Item 7) may extend onto the roof panel.

Figure 44. Vertical seam cap installation



### Flashing Installation

For additional information, see “Flashing Installation Notes,” p. 46.

For hood installations, see “Install Flashing and Hood,” p. 46.

1. See Figure 45, p. 42. Apply Butyl tape (Item 8) to perpendicular to airflow flashing (Item 9) and secure to base rail with screws (Item 4) on front and back of unit (see Detail A in Figure 48, p. 43).

2. Apply Butyl tape (Item 8) to direction-of-airflow flashing (Item 12) and secure to base rails with screws (Item 4). Start at corners to ensure tight corner seams. Apply caulk (Item 14) to create water-tight seal (see Detail A and Detail C in Figure 47, p. 42).
3. Install seam covers (Item 13) to all flashing seams (see Detail D in Figure 48, p. 43).

If second level of unit is shorter than first level, see “Flashing Installation for Stacked Unit With Second Level Shorter Than First,” p. 43.

Figure 45. Flashing installation

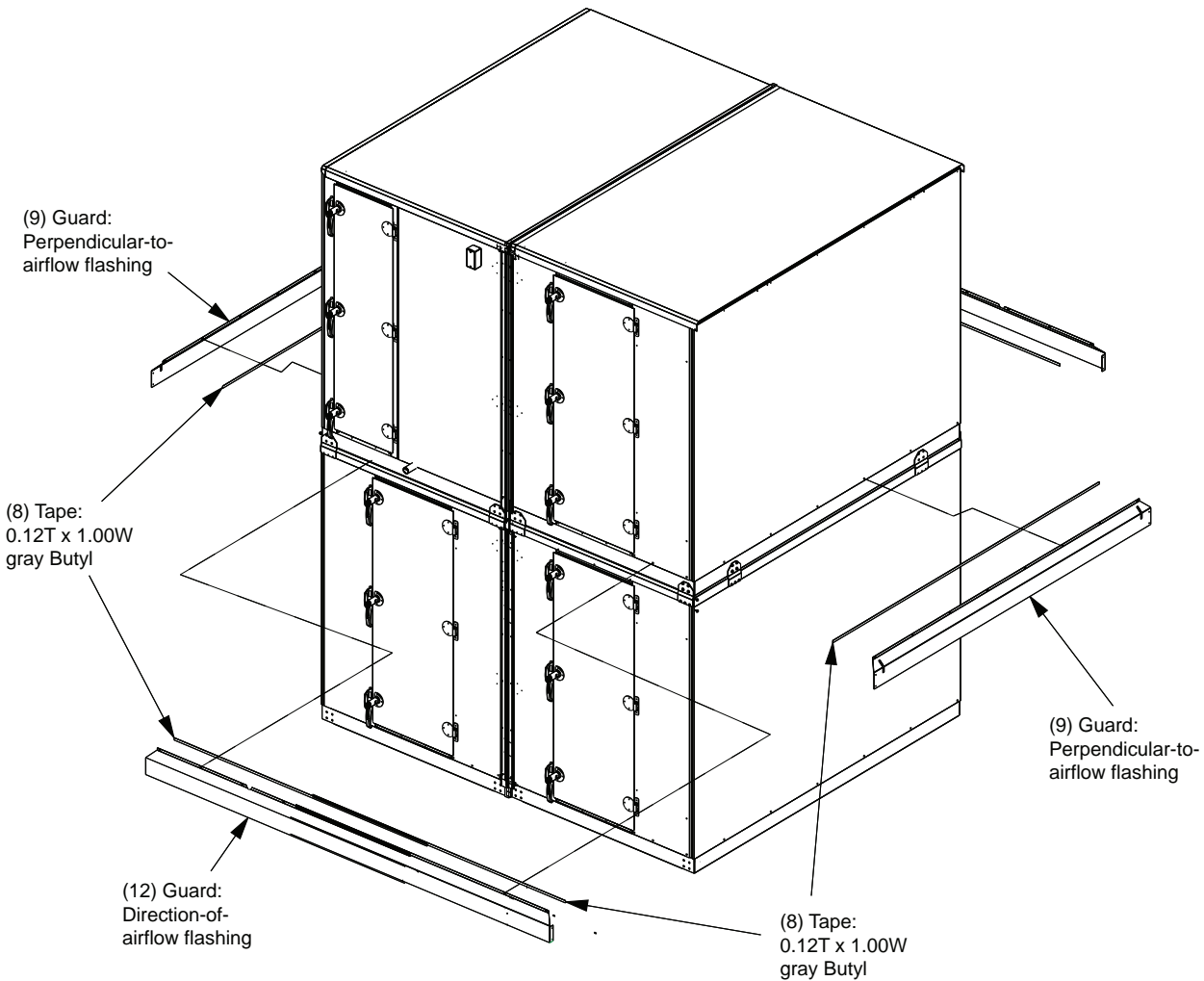


Figure 46. Flashing installation location

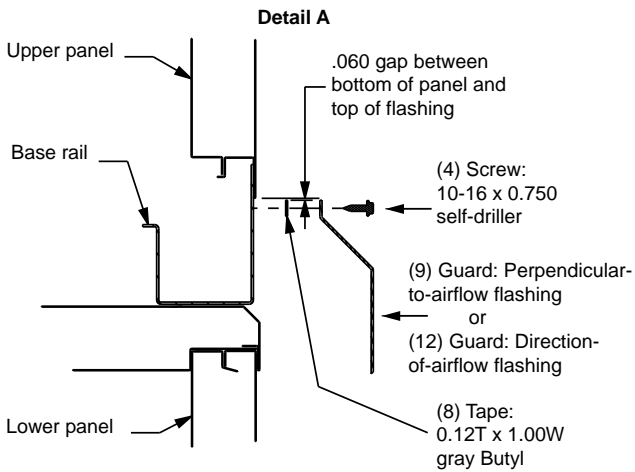
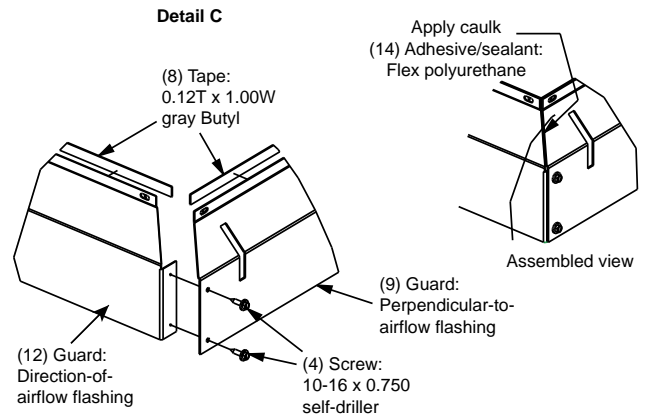
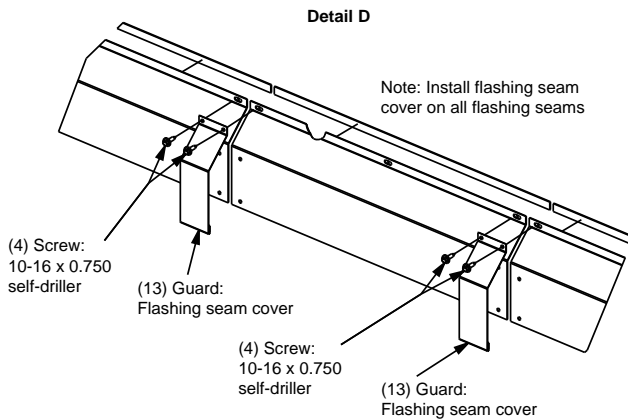


Figure 47. Flashing for corner seams



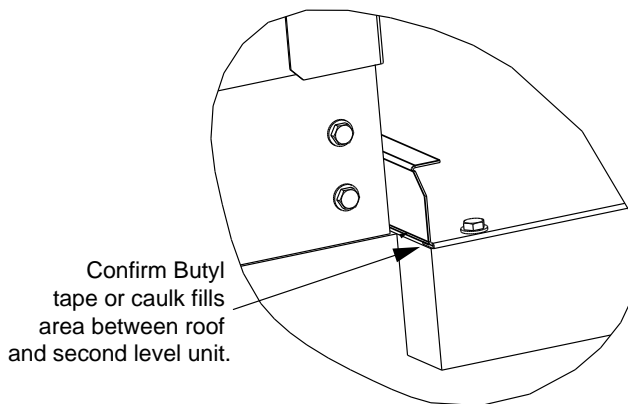
**Figure 48. Flashing seam cover installation**



**Flashing Installation for Stacked Unit With Second Level Shorter Than First**

1. Ensure that first level roof section is properly sealed with Butyl tape (item 8) and/or caulk (Item 14) at the ends. See [Figure 49, p. 43](#).

**Figure 49. Seal first level with caulk or Butyl tape**



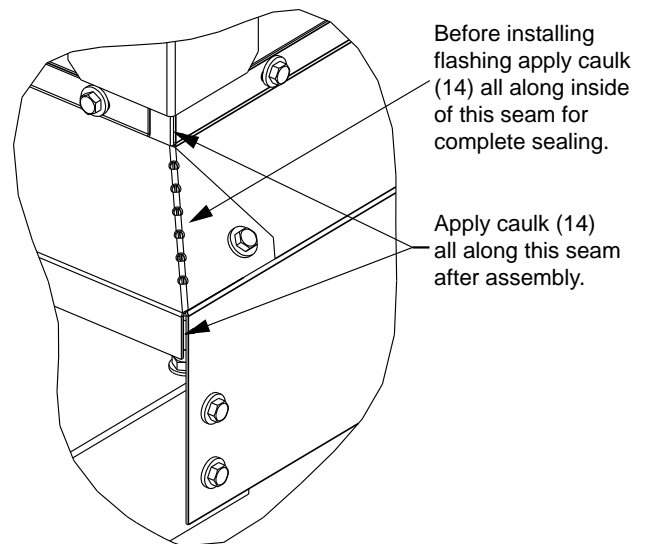
2. Bend end tabs by hand and apply Butyl tape (Item 8) to flashing. See [Figure 50, p. 43](#).

**Figure 50. Bend end tabs and apply Butyl tape to flashing**



3. Secure to base rail with screws (Item 4).
4. Apply caulk (Item 14) to ensure a water tight seal. See [Figure 51, p. 43](#).

**Figure 51. Apply caulk to seal**

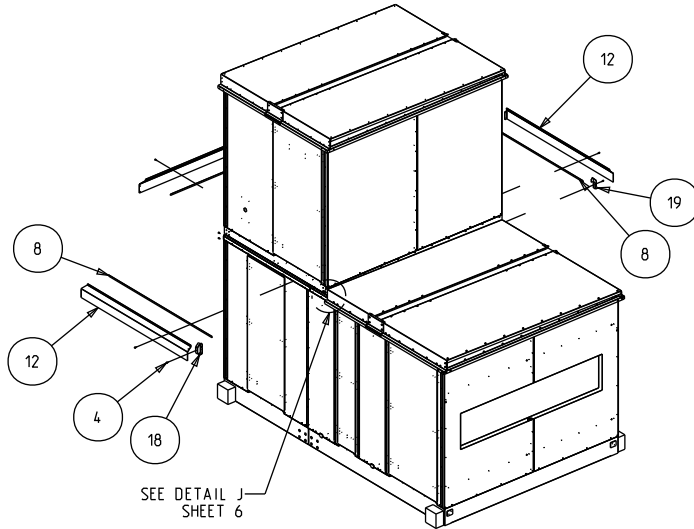


5. For units with a two-piece roof, additional sealing is required in the middle where the first level roof sections meet with second level base rail. Seal vertical flanges of roof with caulk (Item 8) prior to installing flashing. Once flashing is installed, apply caulk (Item 8) to joint, then install direction of airflow roof strip and smooth caulk into crevices to ensure a water tight seal. See [Figure 52, p. 44](#) and [Figure 49 Figure 54, p. 45](#).

**Figure 52. Internal width 27.5 to 96 in. (des seq M or later), non-hurricane units (part 1 of 2)**

**STEPS FOR FLASHING INSTALLATION:**

1. FOR FLASHING INSTALLATION NOTES, SEE SHEET 8.
2. APPLY CAULK (ITEM 14) FOR OUTDOOR ROOF TO BASE RAIL TO CREATE WATER TIGHT SEAL (SEE DETAIL J ON SHEET 6).
3. APPLY BUTYL TAPE (ITEM 8) TO DIRECTION OF AIR FLOW FLASHING (ITEM 12) AND SECURE TO BASE RAILS WITH SCREWS (ITEM 4), STARTING AT CORNERS TO ENSURE TIGHT CORNER SEAMS. APPLY CAULK (ITEM 14) TO CREATE WATER TIGHT SEAL (SEE DETAIL F AND G ON SHEET 4).
4. INSTALL SEAM COVERS (ITEM 13) TO ALL FLASHING SEAMS (SEE DETAIL H ON SHEET 4).
5. ASSEMBLE SKIRT BRACKET (ITEM 18) USING SCREW (ITEM 4) WITH FLASH GUARD (ITEM 12) AT HIGHER PITCH SIDE (SEE DETAIL K SHEET 7).
6. ASSEMBLE SKIRT BRACKET (ITEM 19) USING SCREW (ITEM 4) WITH OUTDOOR ROOF PANEL AT LOWER PITCH SIDE (SEE DETAIL L SHEET 7).



PROPRIETARY DATA	
THIS DRAWING IS PROPRIETARY AND SHALL NOT BE COPIED OR ITS CONTENTS DISCLOSED TO OUTSIDE PARTIES WITHOUT THE WRITTEN CONSENT OF TRANE	
ITEM	DESCRIPTION
4	SCREW; 10-16 X 0.750 SELF DRILLER
8	TAPE; 0.12T X 1.00W, GRAY BUTYL
12	GUARD; DIRECTION OF AIR FLOW FLASHING
13	GUARD; FLASHING SEAM COVER
14	ADHESIVE/SEALANT; FLEX POLYURETHANE
18	SKIRT SUPPORT BRACKET
19	SKIRT SUPPORT BRACKET

**DETAIL J**  
STACKED OUTDOOR ROOF PANEL INSTALL

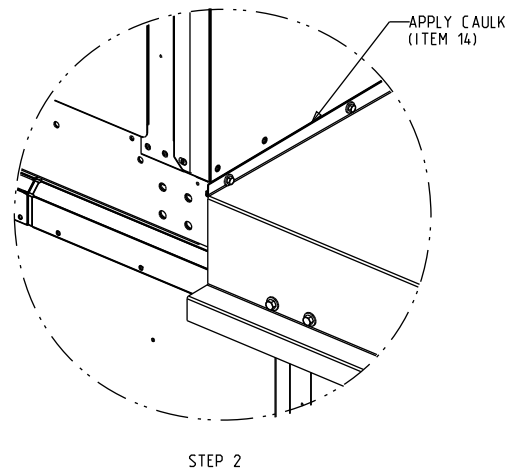
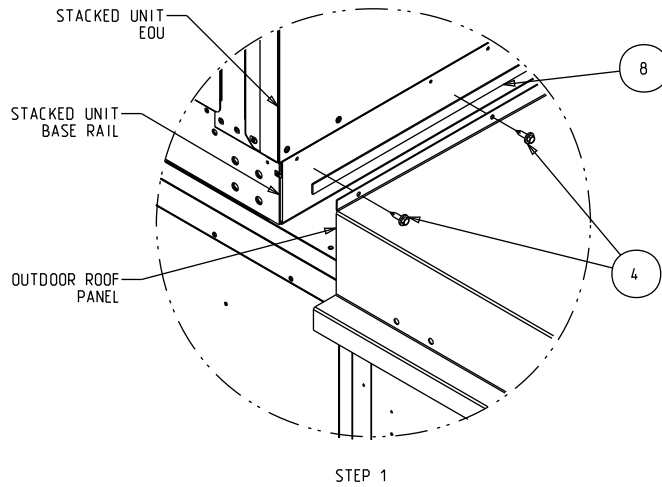


Figure 53. Internal width 27.5 to 96 in. (des seq M or later), non-hurricane units (part 2 of 2)

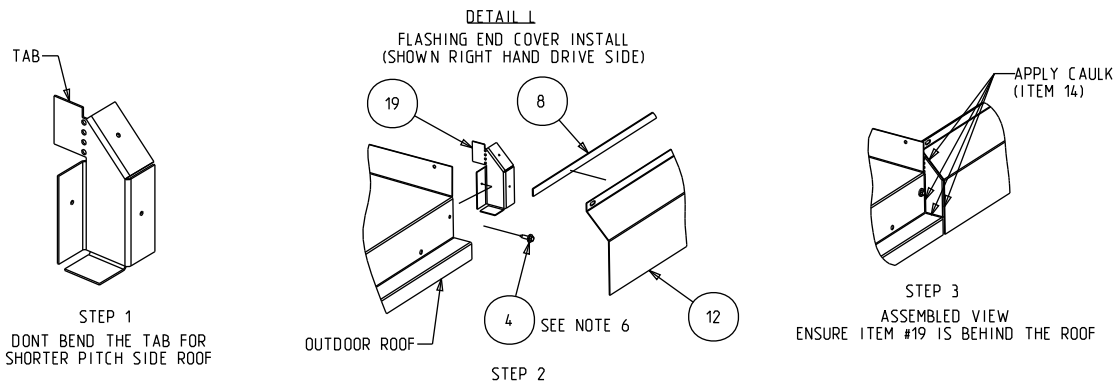
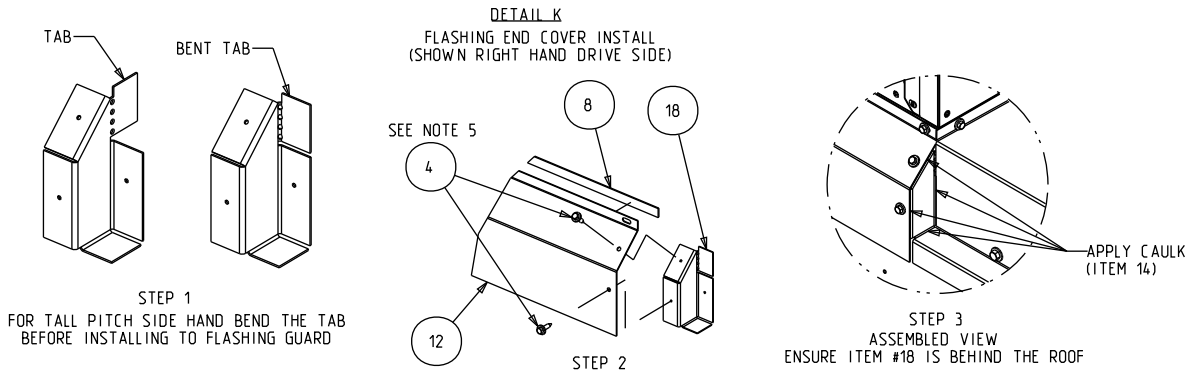
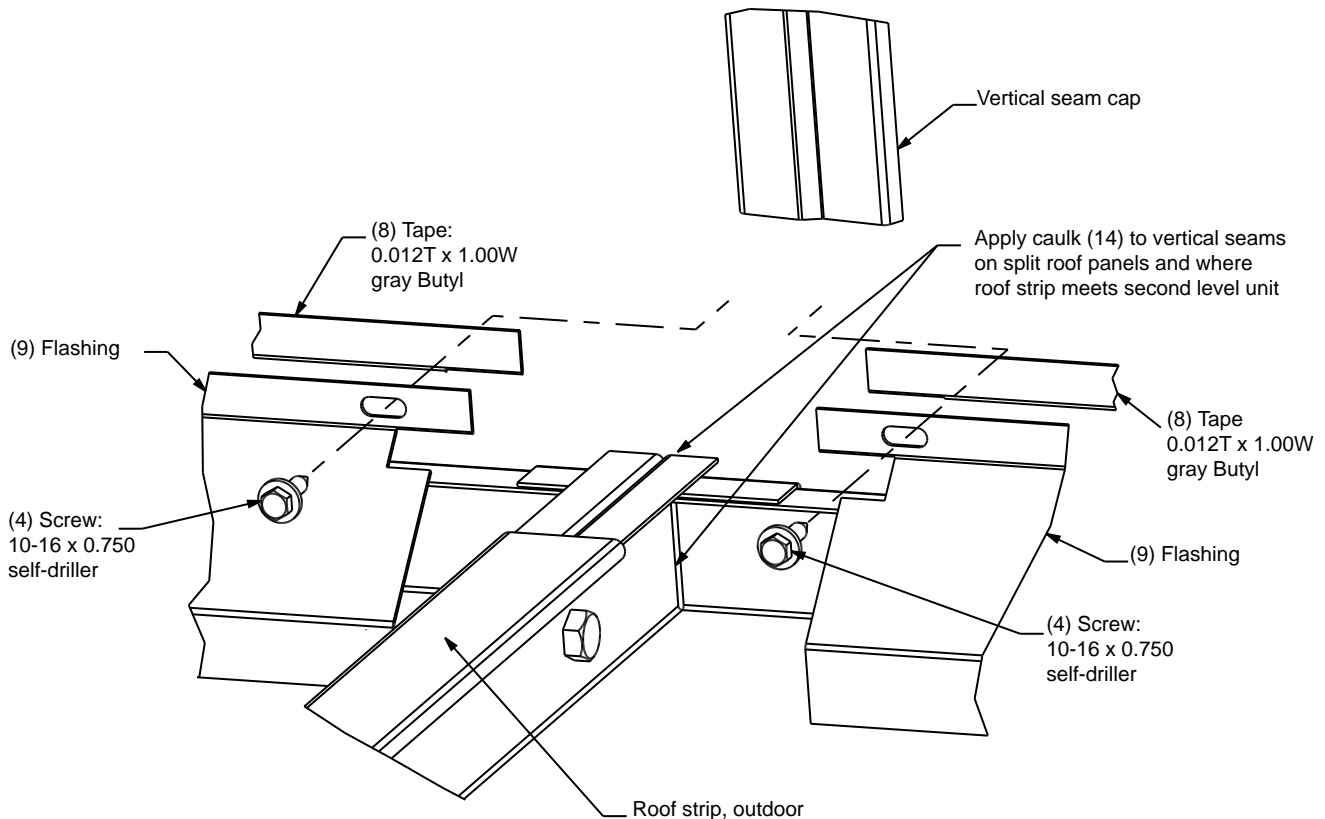


Figure 54. Flashing installation for perpendicular-to-airflow piece if second level of unit is shorter than first level



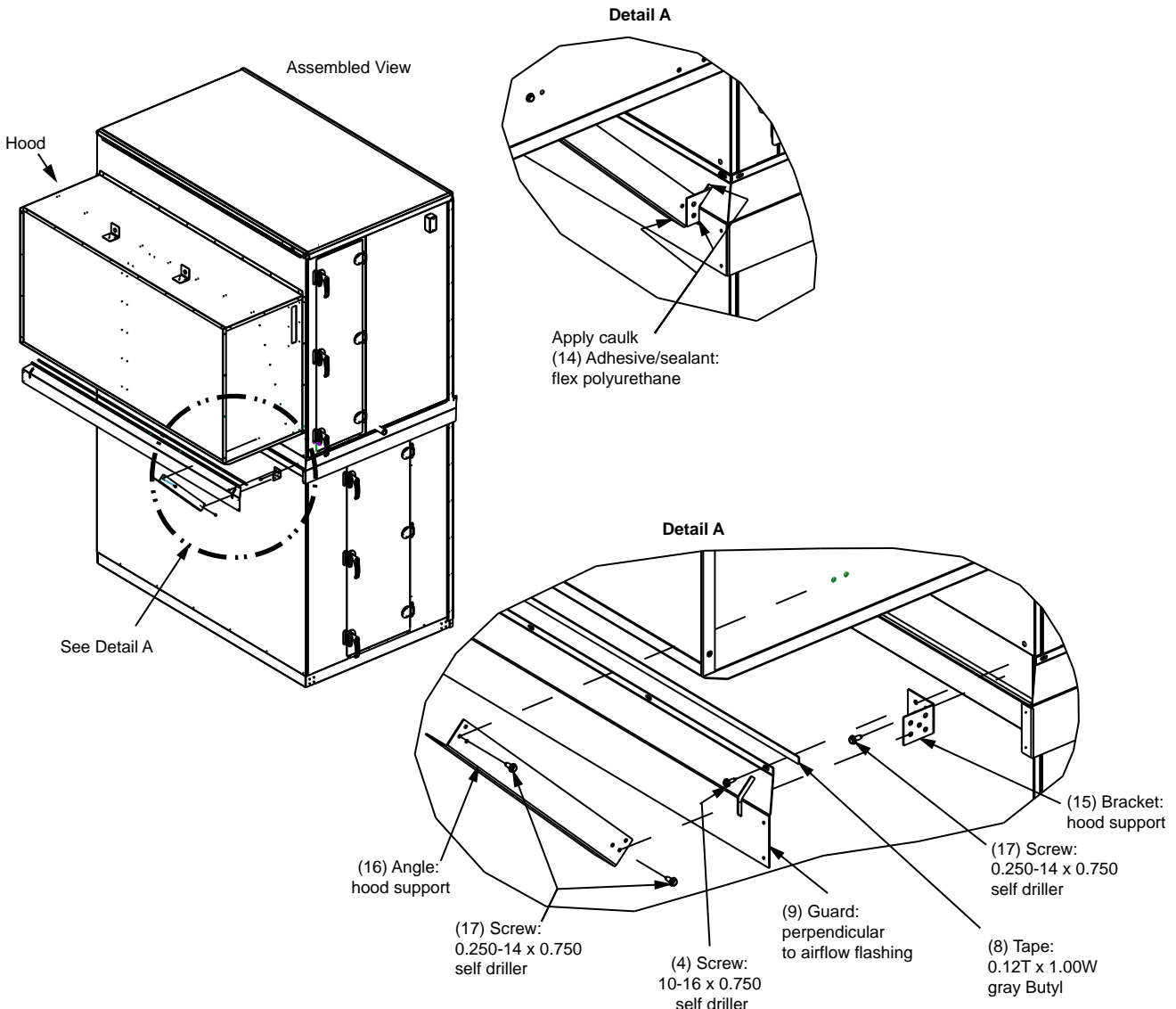
**Flashing Installation Notes**

- Side flashing will have locating features:
  - Right side front and back pieces will have two diamonds and a tab. Intermediate right side pieces (if present) will have two diamonds and length of part will match the ship group length and mounting holes will match hole pattern on the unit.
  - Left side front and back pieces will have one diamond and a tab. Intermediate left side pieces (if present) will have one diamond and length of part will match the ship group length and mounting holes will match hole pattern on the unit.
- Flashing runs full length on front/back of unit. Front/back flashing will not have any locating features and will always have mitre (one piece will have two mitres, two pieces will have one mitre).

**Install Flashing and Hood**

1. See Figure 55, p. 46. Secure two hood support brackets (Item 15) to base rail with screws (Item 17).
2. Apply Butyl tape (Item 8) to flashing (Item 9) and place over hood support brackets (Item 15) using cut in flashing and secure to base rails with screws (Item 4).
3. See “Hood Installation,” p. 37 for hood installation instructions.
4. Secure hood support angles (Item 16) to hood support brackets (Item 15) and to the hood side panels with screws (Item 17).
5. Apply caulk (Item 14) around hood support bracket (Item 15), hood support angle (Item 16), and cutout in perpendicular-to-airflow flashing (Item 9) to ensure watertight seal.

**Figure 55. Stacked unit assembly**



## External Raceway Assembly

For air handling units with factory-installed power wiring extending from the first level to the second level, wiring must be connected and assembled in a raceway. See [Figure 56, p. 47](#).

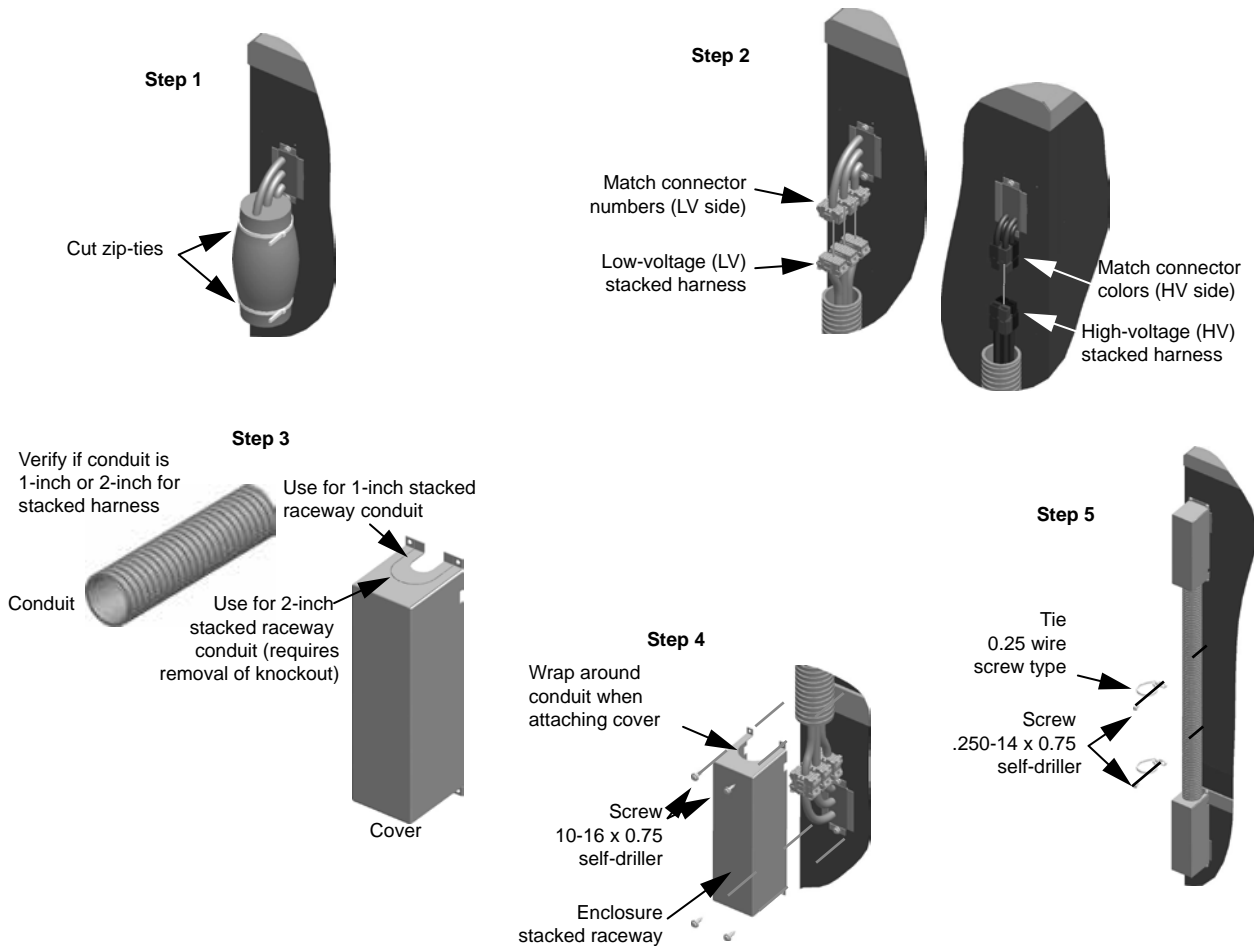
1. Cut zip ties. Remove protective foam cover from connectors.
2. Attach stacked raceway harness connectors, matching connector colors on the high voltage side and connector numbers on the low voltage side.
3. Verify conduit size.

4. Attach covers.
5. Secure conduit. Space tie-downs no greater than 10 inches. Locate cut-screw behind conduit.

### Part numbers:

- Indoor
  - External Raceway Kit: KIT09713
- Outdoor
  - External Raceway Kit - Top: KIT16191
  - External Raceway Kit - Bottom: KIT16192

**Figure 56. External raceway**



## Seismic Application Requirements

Air handling equipment manufactured by Trane is capable of structurally and operationally withstanding the seismic response criteria as required by the International Building Codes (IBC) 2000, 2003, 2006, 2009, 2012, 2015, 2018, 2021, 2024 and CBC 2007, 2010, 2013, 2016, 2019, 2022. Trane has third-party certification for IBC compliance for seismic applications for unit sizes 3-120 and stacked units.

**Note:** If seismic isolation has been specified, the following requirements must be adhered to for installation. Failure to follow these instructions would void the warranty.

### Single Level Design

**Grade to Roof Mounted Non-Isolated Steel dunnage/steel curb:**



## Installation – Mechanical

3/8-inch diameter ASTM A325 or SAE grade 5 bolts attached to unit base located as noted above or 1-inch long 3/16-inch welds at unit base located as noted above.

**Table 10. Anchor requirements for non-stacked units**

SDS	lp	z/h	Attachment Method	Equipment Weight (lbs.)	Seismic Restraint Model	Attachment System	
						Qty per tag	Method
1.483	1.5	1.0	Floor mounted (concrete)	45 psf maximum	Bolt down	2 per mounting location	Anchor: HIT-HY 200+ Rebar A 615 Gr. 60 #5 Embed.: 6.969 inches Edge: 18-in. Conc.: 3000 psi 18-in. thick
0.967	1.5	1.0	Floor mounted (concrete)	45 psf maximum	Bolt down	2 per mounting location	Anchor: HIT-HY 200+ Dia.: HIT-Z-R 1/2-in. Embed.: 4.488 inches Edge: 12-in. Conc.: 3000 psi 12-in. thick
1.850	1.5	1.0	Floor mounted (steel)	45 psf maximum	Bolt down	2 per mounting location	Anchor: A325 Bolt Dia.: 1/2-in. Embed.: N/A Edge: N/A Conc.: N/A
1.850	1.5	1.0	Floor mounted (welded to steel)	45 psf maximum	Welded	1 per mounting location	6-inch weld length with 1/8-inch weld leg

**Notes:**

1. Install clips at shipping split corners.
2. Install clips at shipping splits containing fans or coils at 48 inches maximum on-center spacing.

## Stacked Design

### Grade to Roof Mounted ( $0 \leq Sds \leq 1.85$ ) Non- Isolated

**4000 psi concrete:**

- 5/8 or 3/4-inch diameter Hilti Kwik Bolt TZ carbon steel concrete anchors attached to unit base rails. See [Table 11, p. 48](#).
- Install clips at all ship split corners.
- Install clips at ship splits with a stacked section at 36 inches maximum on-center spacing.

- Install clips at single level ship splits containing fans or coils at 48 inches maximum on-center spacing.
- 3 1/8 or 4 3/4-inch minimum anchor embedment. See [Table 11, p. 48](#).
- 9 or 12-inch minimum distance to the nearest edge. See [Table 11, p. 48](#).
- 9 or 12-inch minimum concrete slab thickness. See [Table 11, p. 48](#).

**Steel dunnage/steel curb:**

1/2-inch diameter ASTM A325 or SAE Grade 5 bolts attached to unit base located as noted above or 1-inch long 3/16-inch welds at unit bases located as noted above.

**Table 11. Anchor requirements for stacked units**

SDS	lp	z/h	Attachment Method	Equipment Weight (lbs.)	Seismic Restraint Model	Attachment System	
						Qty per tag	Method
0.421	1.5	1.0	Floor mounted (concrete)	150 psf maximum	Bolt down	See note below	Anchor: HIT-KB TZ CS Dia.: 5/8-in. Embed.: 3.125 inches Edge: 9-in. Conc.: 4000 psi 9-in. thick
0.637	1.5	1.0	Floor mounted (concrete)	150 psf maximum	Bolt down	See note below	Anchor: HIT-KB TZ CS Dia.: 3/4-in. Embed.: 4.75 inches Edge: 12-in. Conc.: 3000 psi 12-in. thick
1.850	1.5	1.0	Floor mounted (steel)	150 psf maximum	Bolt down	See note below	1/2-in. dia. ASTM A325/ Grade 5 bolts

**Table 11. Anchor requirements for stacked units (continued)**

1.850	1.5	1.0	Floor mounted (steel)	45 psf maximum	Welded to steel	See note below	1/8-in. thick, 6-in. long weld
-------	-----	-----	-----------------------	----------------	-----------------	----------------	--------------------------------

**Notes:**

1. Install anchors at shipping split corners.
2. Install anchors at shipping splits with a stacked module at 36 inches maximum spacing.

### Anchoring

Lifting lugs should be used to anchor the unit at the ends of each shipping split. Per the anchor requirements, additional anchoring may be needed. If so, anchors will be provided and installed on the unit. An example of a seismic anchor is shown in [Figure 57, p. 49](#).

Anchor selection meets or exceeds IBC 2000, 2003, 2006, 2009, 2012, 2015, 2018, 2021, 2024 and CBC 2007, 2010, 2013, 2016, 2019, 2022 compliance requirements.

Special Inspection per IBC Section 1704 is required on all installations. All anchors listed above must be installed to meet compliance.

**Figure 57. Seismic anchor**

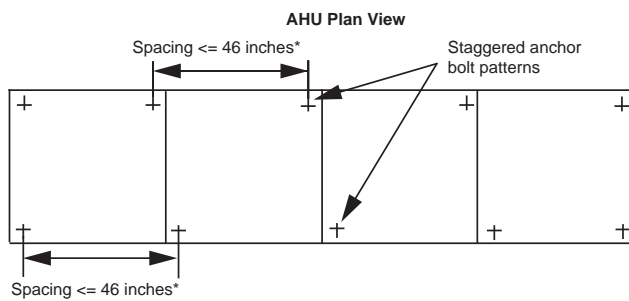


### Pipe Cabinet Installation

Nested U channels and L angle have to be removed to install the pipe cabinet to the unit and reinstall per hurricane certification guidelines. See [Figure 59, p. 50](#).

1. Remove the fasteners from the top of the nested U channel.
2. Remove the U channel from the unit base L angle and the pipe cabinet base L angle.
3. Remove the corner fasteners from the pipe cabinet base and the unit base L angle. These fasteners are not required to be put back.

**Figure 58. Seismic anchor pattern**



\*Only if not anchoring each functional section

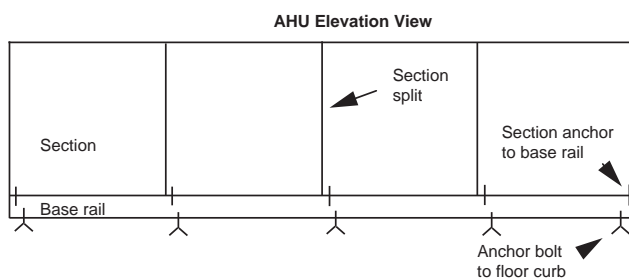
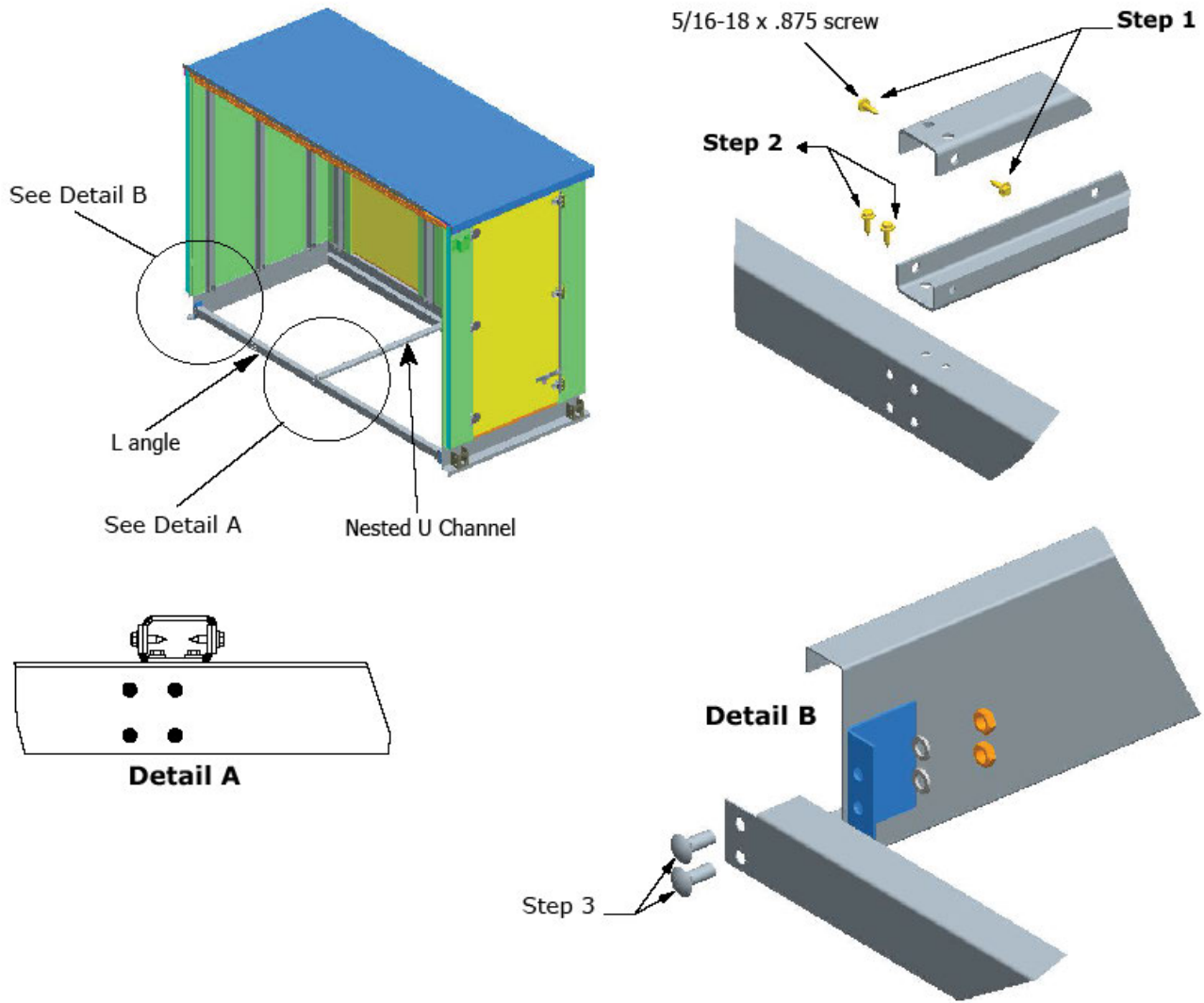
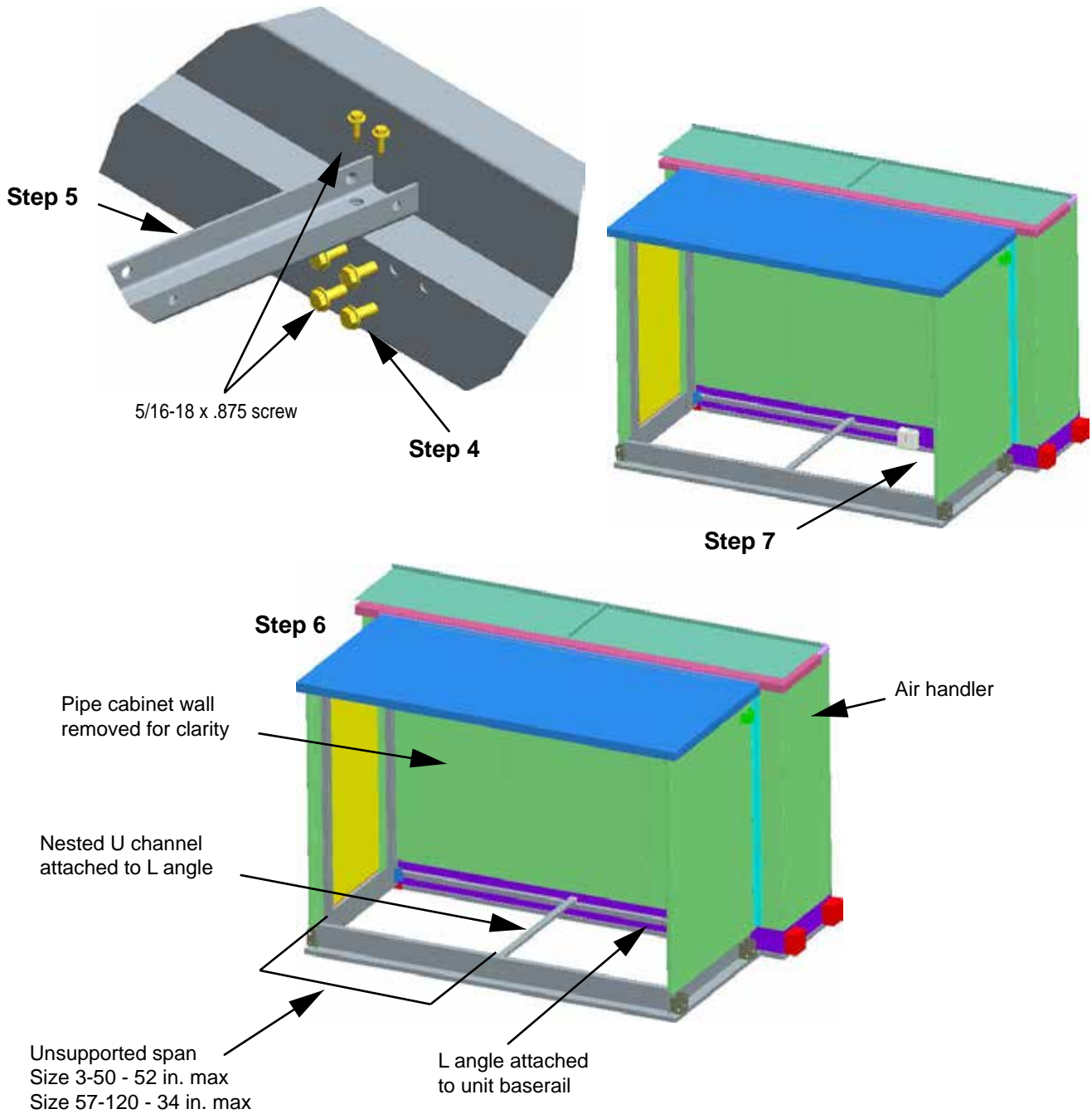


Figure 59. Pipe cabinet installation for hurricane applications



4. Attach the unit base L angle from the pipe cabinet to the unit base rail. See Step 4 in [Figure 60, p. 51](#).
5. Attach a U channel to the unit base L angle. Make sure to clear any coil piping. Make sure to attach enough nested U channels to comply to the unsupported span. See Step 5 in [Figure 60, p. 51](#).
6. Locate the pipe cabinet in place, and reinstall the U channel to the pipe base L angle and reinstall the top U channel to the nest (see Step 1 in [Figure 59, p. 50](#)).
7. When the L angle interferes with the unit base rail lifting lugs or splice plate, mark and cut L angle section to clear the component. If excess L angle is not needed for nested U channel, leave it off. See [Figure 60, p. 51](#).

Figure 60. Pipe cabinet installation for hurricane applications





# Component Installation

The components in the air handler may have installation requirements that could affect the unit's performance.

## Dampers

Dampers are factory-installed and adjusted and can be found in mixing box sections. There are two damper blade configurations available: parallel-blade and opposed-blade.

Traq™ dampers are another type of damper available in mixing box sections. Traq dampers have only one blade configuration - opposed. They have two control applications available - standard Traq dampers and low-flow Traq dampers. Low-flow Traq dampers are always not linked and consist of two damper sets - one set for minimum outside air measurement and one set for economizing. Each will have its own VCM.

The air handler is available with factory-mounted controls or end devices. If the unit is not ordered with controls or end devices, it is the installer's responsibility to provide and install the damper actuators. To size the actuators see "Damper Torque Requirements," p. 52.

Mixing sections are designed for the damper actuators to be direct coupled and installed in the air stream. If other provisions are required, modifications to the section will be the responsibility of the installing contractor.

## Damper Torque Requirements

### Horizontal Blade Rectangular Dampers

- Parallel airfoil damper = 7.00 in.-lb./ft<sup>2</sup>
- Opposed airfoil damper = 5.00 in.-lb./ft<sup>2</sup>

### Vertical Blade Dampers

- Parallel airfoil damper = 12.00 in.-lb./ft<sup>2</sup>
- Opposed airfoil damper = 12.00 in.-lb./ft<sup>2</sup>

### Traq Dampers

- Traq 13-in. diameter damper = 18.00 in.-lb./ft<sup>2</sup>
- Traq 16-in. diameter damper = 22.50 in.-lb./ft<sup>2</sup>
- Traq 20-in. diameter damper = 33.00 in.-lb./ft<sup>2</sup>
- Traq 24-in. diameter damper = 36.00 in.-lb./ft<sup>2</sup>
- Traq 28-in. diameter damper = 37.50 in.-lb./ft<sup>2</sup>

## Fans

The fan section can be configured as either draw-thru or blowthru. Review the submittals and unit tagging information prior to assembly to determine placement.

## ⚠ WARNING

### Hazardous Service Procedures!

Failure to follow all precautions in this manual and on the tags, stickers, and labels could result in death or serious injury.

Technicians, in order to protect themselves from potential electrical, mechanical, and chemical hazards, **MUST** follow precautions in this manual and on the tags, stickers, and labels, as well as the following instructions: **Unless specified otherwise, disconnect all electrical power including remote disconnect and discharge all energy storing devices such as capacitors before servicing. Follow proper lockout/tagout procedures to ensure the power can not be inadvertently energized. When necessary to work with live electrical components, have a qualified licensed electrician or other individual who has been trained in handling live electrical components perform these tasks.**

## Fan Isolation

The fan-and-motor assembly is internally isolated. The fan and motor bases are bolted to a minimum of four spring isolators. The isolators are secured to the fan section support base.

Shipping tie-down bolts are bolted adjacent to the isolators between the fan isolation base and the isolator support frame. The shipping tie-downs secure the isolation base to the support assembly to prevent any damage to the fan section during shipment.

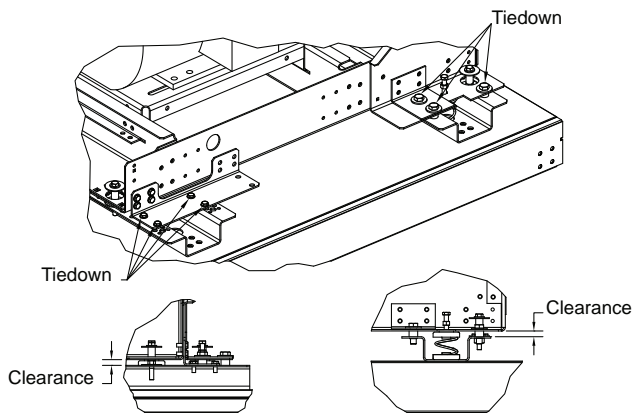
**Note:** Remove the tie-downs **only** if the factory-provided isolation is to be used.

## Adjusting the Isolators

Once the shipping tie-downs are removed and the internal isolation is released, it may be necessary to adjust the isolators to achieve the proper operation height of the fan and motor isolation base.

Minimum required clearance is 0.5 inches. To determine the isolator clearances on all unit sizes, measure between the top of the cabinet channel and the bottom of the isolation base channel.

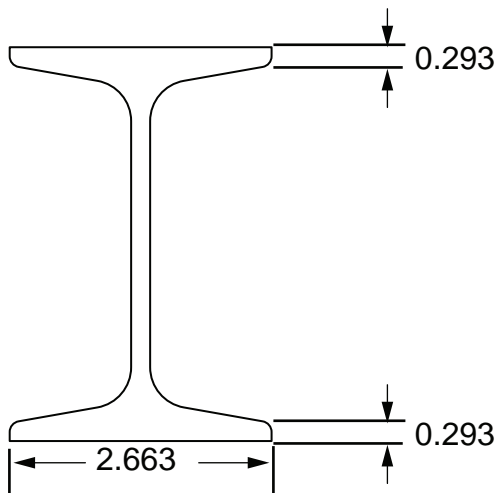
**Figure 61. Tie-down removal**



### Motor Removal Rail

The motor removal rail provide is to be used for fan motor removal and installation. The hoist is not provided by the factory. For hoist selection, please refer to the rail cross section provided in [Figure 62, p. 53](#). The maximum load for the rail is 500 lbs (hoist plus motor).

**Figure 62. Motor removal rail**



### Filters

Bag and cartridge filter sections can be used as a pre-filter section, a final filter section, or both. This use is determined by the filter's placement in relation to the fan.

- A final filter is placed after the fan.
- A pre-filter is placed before the fan.

**Note:** Cartridge and bag filters provided by Trane are fitted with a 7/8-inch header that fits in the filter track. If using filters supplied by another manufacturer, filters should be purchased with a 7/8-inch header. In some cases it may be necessary to gasket other manufacturers' filters to ensure a good air seal.

Filters should be installed when the unit is set. This will protect internal components, such as the heating and cooling coils.

### Final Filter Section

A final filter section should not be bolted directly to the face of a fan section. One or more intermediate sections must be placed between the fan discharge and the filter section.

### Pre-Filter Section

A pre-filter section has no special installation requirements unless placed directly upstream of a plenum fan. In these configurations, ensure a blank section is placed between the fan inlet and the filter section.

Trane recommends the use of disposable pre-filters with high-efficiency filters. Disposable pre-filters slide into the mounting tracks just ahead of the bag/cartridge filters.

### Filter Installation

**⚠ WARNING**

**Hazardous Voltage!**

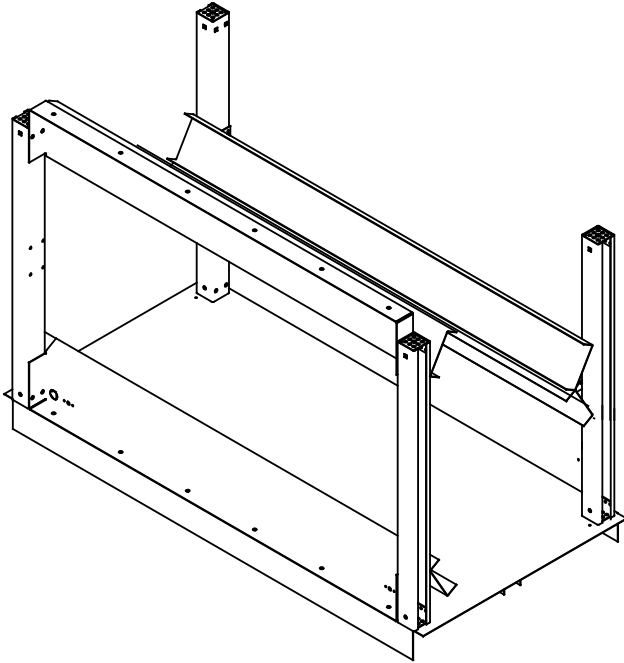
Failure to disconnect power before servicing could result in death or serious injury. Disconnect all electric power, including remote disconnects before servicing. Follow proper lockout/tagout procedures to ensure the power can not be inadvertently energized. Verify that no power is present with a voltmeter.

To install filters:

1. Disconnect the power to the unit.
2. Open the filter section access door.
3. Slide the filters into the tracks.
 

**Note:** Bag filters must be installed with the pleats in the vertical plane.
4. The block-off is permanently installed and will create a seal when the access door is closed.
5. Close the access door slowly to allow any gasketing to compress.

**Figure 63. Filter block-off placement**



## Duct Connections

All duct connections to the air handlers should be installed in accordance with the standards of the National Fire Protection Association (NFPA):

- NFPA 90A for installing air conditioning and ventilating systems other than residence type.
- NFPA 90B for residence-type warm air heating and airconditioning systems.

See unit submittal documentation for additional duct mounting information.

## Fan Discharge Connections

To ensure the highest fan efficiency, duct turns and transitions must be made carefully, minimizing air friction losses and turbulence. Proper ductwork installation, as outlined by such organizations as Sheet Metal and Air Conditioning Contractors National Association, Inc. (SMACNA), should be followed closely.

Indoor unit fan sections with rectangular or round openings should have flanged ductwork attached to bottom panel opening. When using lined ducts, the insulation should not obstruct the discharge opening. For plenum fan sections with bell mouth fittings, see “[Bell Mouth Discharge Connections](#),” p. 56.

## Damper Connections

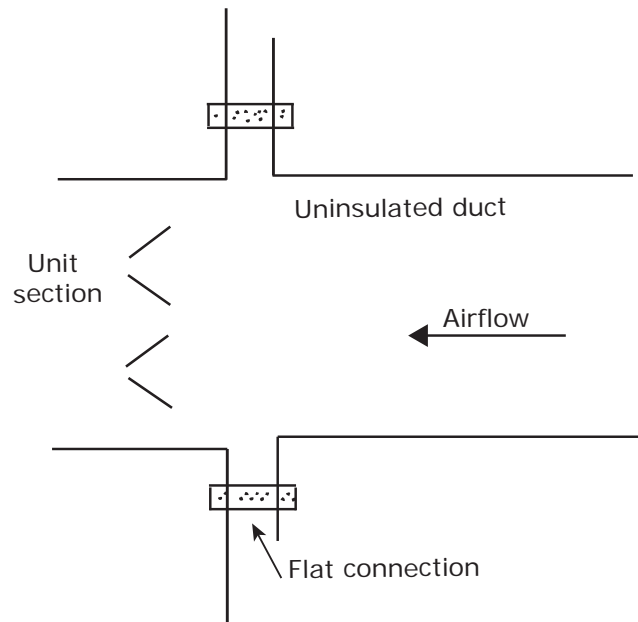
Standard damper sections include mixing sections, filter mixing sections, face dampers sections, internal face-andbypass sections. There are two damper blade configurations available - parallel-blade and opposed-

blade. Traq™ dampers are another type of damper available in mixing box sections.

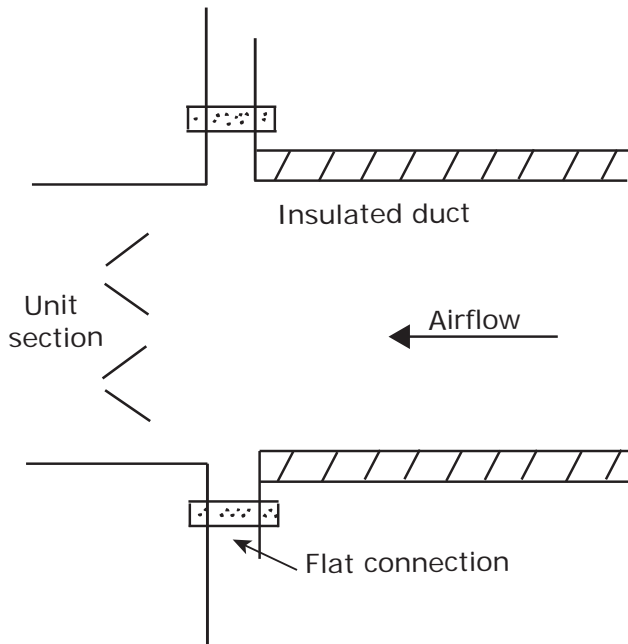
Ductwork attached to the standard damper sections should be sized to fit the opening of the damper. Duct opening dimensions are provided in the submittals. When using lined duct, ensure that the insulation does not obstruct the damper opening (see [Figure 64](#), p. 54 and [Figure 65](#), p. 55).

**Note:** Damper blades should be checked for proper operation from full-open to full-closed position before unit start up. Damper blade positioning may have changed due to shipping and handling vibrations.

**Figure 64. Typical duct flat/flange connection - uninsulated or externally insulated**



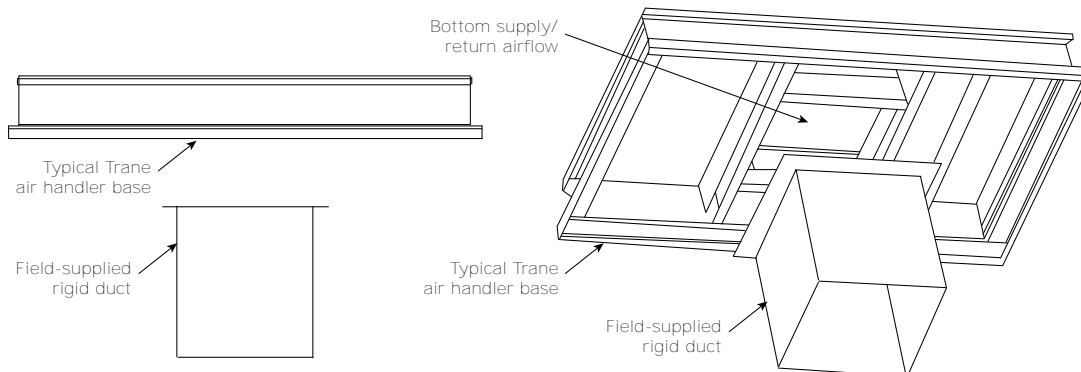
**Figure 65. Typical section with duct flat/flange connection- internally insulated**



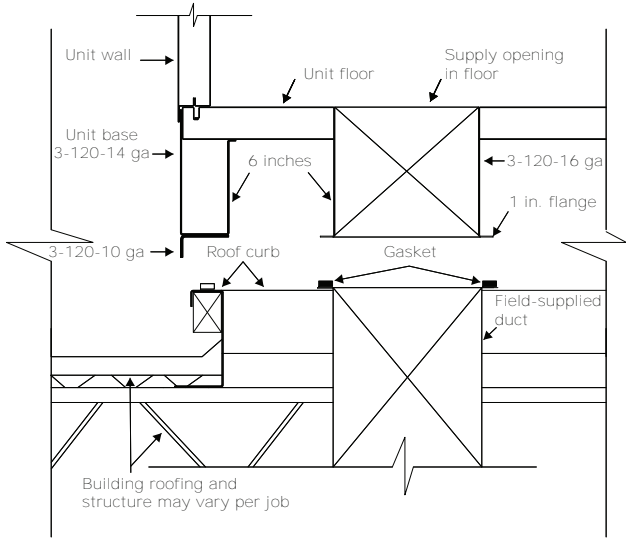
### Bottom Opening Duct Installation

1. Install gasket to duct flange to ensure air tight seal.
2. Install duct into place underneath framed opening in unit base per [Figure 66, p. 55](#). Refer to factory curb layout provided with unit submittals for duct size and location.
3. Bottom of unit base elevation is flush with duct opening in bottom of unit (see [Figure 67, p. 56](#) and [Figure 68, p. 56](#)).

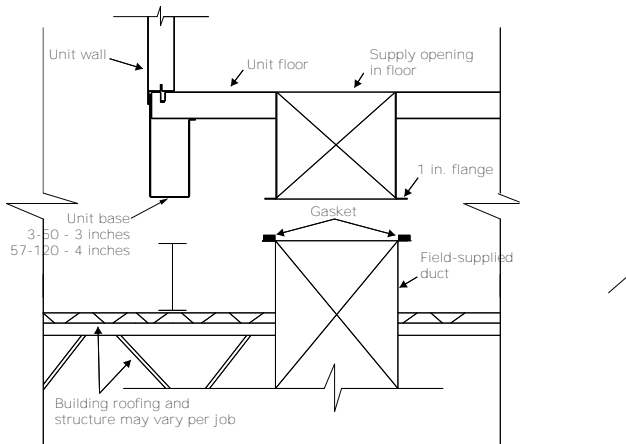
**Figure 66. Field-supplied duct connection to AHU bottom supply/return air opening**



**Figure 67. Field-supplied duct connection details - curb mount for outdoor units**



**Figure 68. Field-supplied duct connection details - pier mount for outdoor units**



## Discharge Plenum Connections

Discharge plenum sections are available with or without openings. Sections with rectangular and round openings have a framed opening that can be used to secure the duct to the frames. If the duct is lined, it is important the insulation does not obstruct the opening of the section.

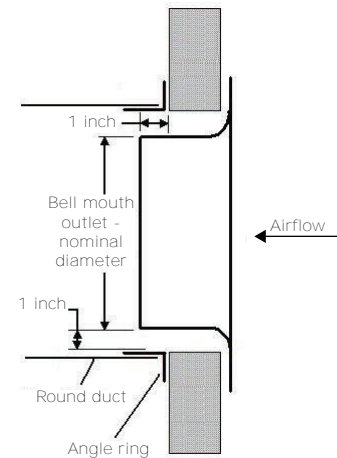
For a discharge plenum with field-cut openings, attach the duct to the side panel.

## Bell Mouth Discharge Connections

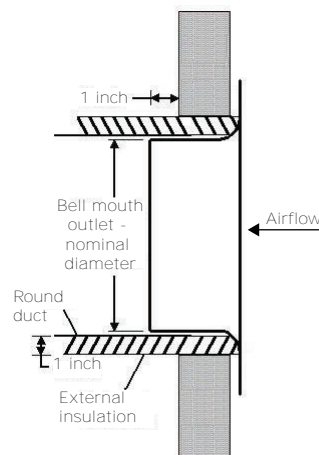
Round duct connections to be fastened to plenum fan and discharge plenum sections with bell mouth discharge openings should be sized to attach to the casing or directly to the bell mouth fitting. Attachment to the casing requires the round duct diameter to be sized two inches larger than the nominal bell mouth outlet. An angle ring with a flat

flange should be affixed to the round duct to secure the duct to the casing (see Figure 69, p. 56). Attachment to the bell mouth fitting requires the duct and fitting to be insulated by the installing contractor up to the bell mouth radius to prevent condensation (see Figure 70, p. 56). The bell mouth fitting extends through the casing by one inch.

**Figure 69. Securing round duct to casing over bell mouth outlet**



**Figure 70. Securing round duct to bell mouth outlet**

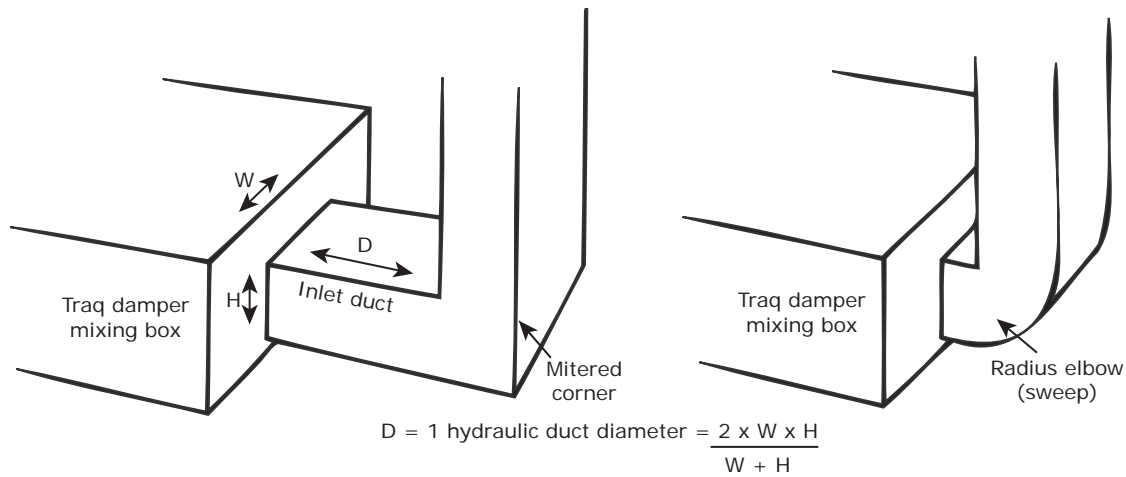


## Traq Damper Connections

Size the duct connections to attach to the specified portion on the face of the mixing box that the duct connection completely covers all of the Traq damper.

For a mitered corner, provide one hydraulic duct diameter between the entering face of the Traq dampers and the duct turn. For a radius elbow, or sweep, place the elbow directly against the face of the Traq dampers (see Figure 71, p. 57).

Figure 71. Traq damper duct connections



### Other Connections

Access, filter, and other sections may have open inlets with a 2-inch (sizes 3-120) panel frame for connecting the ductwork. If the duct is lined, it is important the insulation does not obstruct the opening of the section.

Figure 72. Typical duct flat/flange end-of-unit (EOU) connection - uninsulated

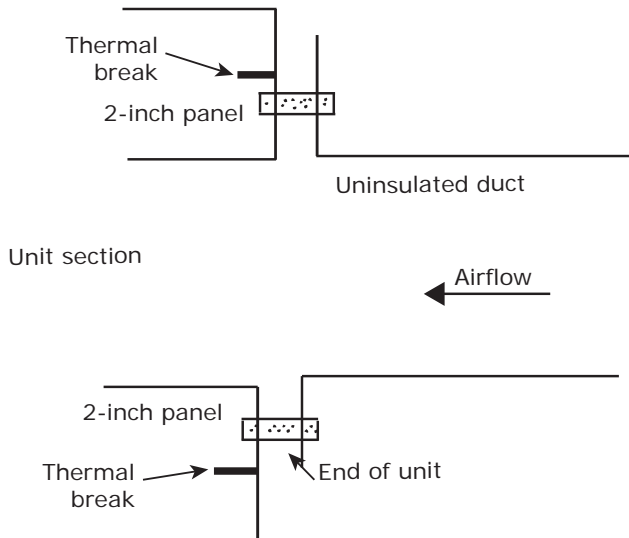
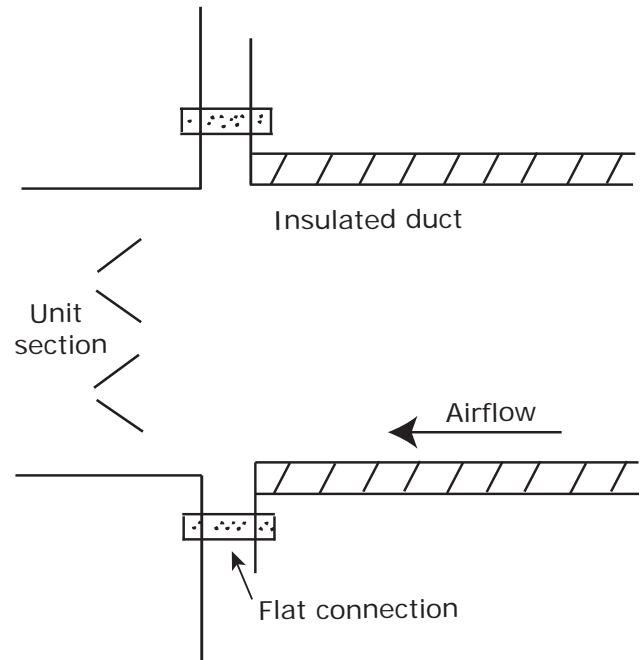


Figure 73. Typical duct flat/flange end-of-unit (EOU) connection - insulated





# Piping and Connections

## NOTICE

### Connection Leaks!

Failure to follow instructions below could result in damage to the coil header and cause connection leaks.

Use a backup wrench when attaching piping to coils with copper headers. Do not use brass connectors because they distort easily.

## NOTICE

### Overtightening!

Failure to follow instructions below could result in damage to the coil header.

Do not use teflon-based products for any field connections because their high lubricity could allow connections to be overtightened.

## NOTICE

### Leakage!

Failure to follow instructions below could result in equipment damage.

Properly seal all penetrations in unit casing from inner to outer panel in order to prevent unconditioned air from entering the module, as well as prevent water from infiltrating the insulation.

## General Recommendations

Proper installation, piping, and trapping is necessary to ensure satisfactory coil operation and to prevent operational damage:

- Support all piping independently of the coils.
- Provide swing joints or flexible fittings on all connections that are adjacent to heating coils to absorb thermal expansion and contraction strains.
- If the coil was ordered with factory-mounted controls, install the control valves. The valves ship separately.

**Note:** The contractor is responsible for supplying the installation hardware.

- For best results, use a short pipe nipple on the coil headers prior to making any welded flange or welded elbow type connections.
- Extended drain and vent connections are provided as standard on D1 and D2 coils only. If extended drains and vents are required on other water coils, they must be field-installed or ordered as specials from the factory.

**Note:** Drain and vent connections are optional for standard coils. Penetrations will not be in the panel; a pilot hole will be factory-provided if drain and vent connections are indicated.

- Pipe coils counter flow to airflow.
- When attaching the piping to the coil header, make the connection only tight enough to prevent leaks.

**Note:** Do not exceed 200 foot-pounds of torque on supply and return connections. Do not exceed 25 foot-pounds of torque on drain and vent connections.

- Use pipe sealer on all thread connections.
- After completing the piping connections, seal around pipe from inner panel to outer panel.

## Drain Pan Trapping

## ⚠ WARNING

### No Step Surface!

Failure to follow instruction below could result in death or serious injury.

Do not walk on the sheet metal drain pan. Walking on the drain pan could cause the supporting metal to collapse and result in the operator/technician falling.

## NOTICE

### Water Damage!

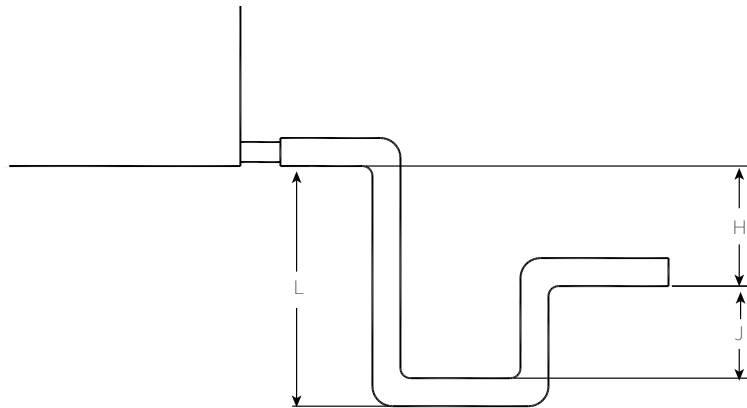
Failure to follow instructions below could result in water damage.

When more than one section has a drain pan, trap each section individually. Connecting multiple drains to a common line with only one trap could result in condensate retention and water damage to the air handler or adjoining space.

Threaded condensate drain connections are provided on only one side of the coil section. Pitch the connection lines horizontal or downward toward an open drain. Trane recommends installing a plug to facilitate cleaning of the trap.

Figure 74, p. 59 illustrates the proper trapping, piping, and operation of the trap. Use the formula under the figure to determine the correct minimum depth for the condensate trap. If a section has a drain pan for cleaning purposes only, it does not need a trap; however, a cap or shutoff valve should be installed on the drain connection. Only sections handling condensate, such as a cooling coil section or moisture eliminator section, require a trap.

Figure 74. Drain pan trapping for negative and positive pressure applications



Section under negative pressure

Section under positive pressure

$L = H + J + \text{pipe diameter}$  where:  
 $H = 1$  inch for each inch of negative pressure plus 1 inch with loaded filters  
 $J = 1/2$  H

$L = H + J + \text{pipe diameter}$  where:  
 $H = 1/2$  inch (minimum)  
 $J = 1/2$  inch plus the unit positive static pressure at coil discharge (loaded filters)

## Steam Coil Piping

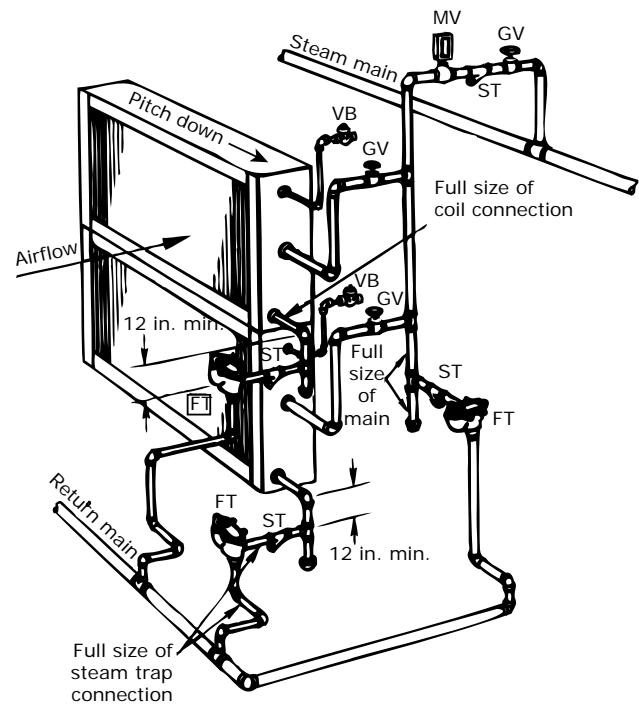
Air handlers fitted with steam coils have labeled holes for piping penetrations. Figure 75, p. 59 illustrates a typical steam coil piping configuration. See Table 12, p. 59 for the codes of system components in these figures.

The coil condensate return line must be piped full size of the condensate trap connection, except for a short nipple screwed directly into the coil header's condensate return tapping. Do not bush or reduce the coil return trapping size.

Table 12. Code of system components for piping figures

Code	System component
FT	Float and thermostatic steam trap
GV	Gate valve
OV	Automatic two-position (ON-OFF) control valve
VB	Vacuum breaker
ST	Strainer
AV	Automatic or manual air vent
MV	Modulating control valve

Figure 75. Typical piping for Type NS steam coils and horizontal tubes for horizontal airflow



### NOTICE

#### Equipment Damage!

Failure to follow instructions below could result in equipment damage. Use only the recommended vacuum breaker size and configuration.

To prevent coil damage:

## Piping and Connections

- Install a 1/2-in. NPT, 15 degree swing check valve vacuum breaker with cracking pressure of 0.25-inches Hg (3.4-inches water) or lower at the top of the coil. This vacuum breaker should be installed as close to the coil as possible.
- For coil type NS, install the vacuum breaker in the unused condensate return tapping at the top of the coil.
- Vent the vacuum breaker line to atmosphere or connect it into the return main at the discharge side of the steam trap.

**Note:** Vacuum breaker relief is mandatory when the coil is controlled by a modulating steam supply or automatic two position (ON-OFF) steam supply valve. Vacuum breaker relief is also recommended when face and bypass control is used.

### NOTICE

#### Coil Damage!

Failure to follow instructions below could result in equipment damage.

Condensate must flow freely from the coil at all times to prevent coil damage from water hammer, unequal thermal stresses, freeze-up and/or corrosion.

Proper steam trap installation is necessary for satisfactory coil performance and service life. For steam trap installation:

1. Install the steam trap discharge 12-inches below the condensate return connection. Twelve inches provides sufficient hydrostatic head pressure to overcome trap losses and ensures complete condensate removal.
    - a. Use float and thermostatic traps with atmospheric pressure gravity condensate return, with automatic controls, or where the possibility of low-pressure supply steam exists. (Float and thermostatic traps are recommended because of gravity drain and continuous discharge operation.)
    - b. Use bucket traps only when the supply steam is not modulated and is 25 psig or higher.
- Note:** Trane steam coils require a minimum of 2 psi of pressure to assure even heat distribution.
2. Trap each coil separately to prevent holding up condensate in one or more of the coils.
  3. Install strainers as close as possible to the inlet side of the trap.
  4. If installing coils in series airflow, control each coil bank independently with an automatic steam-control valve. Size the traps for each coil using the capacity of the first coil in direction of airflow.
  5. Use a modulating valve that has linear flow characteristics to obtain gradual modulation of the coil steam supply.

**Note:** Do not modulate systems with overhead or pressurized returns unless the condensate is drained by gravity into a receiver, vented to atmosphere, and returned to the condensate pump.

6. Pitch all supply and return steam piping down 1-inch for every 10-feet in the direction of the steam or condensate flow.

**Note:** Do not drain the steam mains or take-offs through the coils. Drain the mains ahead of the coils through a steam trap to the return line.

7. Ensure overhead returns have 1 psig of pressure at the steam trap discharge for every 2-feet of elevation for continuous condensate removal.

## Water Coil Piping

Type 5A, 5W, D1, W, UW, TT, P,2, P4, and P8 water coils are self-venting only if the water velocity exceeds 1.5 feet per second (fps) in the coil tubes. Type D2, UA, UU, and WD water coils are self-venting only if the water velocity exceeds 2.5 fps in the coil tubes.

See the unit submittals for coil water velocity. If the water velocity is below these minimums, vent the coil by one of the following methods:

1. Install an air vent in the top pipe plug tapping of the return header.
2. When the return line rises above the top of the coil, vent from the top of the return header horizontally to the return piping.

**Note:** TT coils are designed with larger than normal end tube sheet holes to allow for maximum expansion. Air leakage around tubes should be expected and handled by capping over coil ends or by sealing around tubes with a pliable sealant such as silicone.

**Figure 76. Typical piping for type 5W one-row water coil**

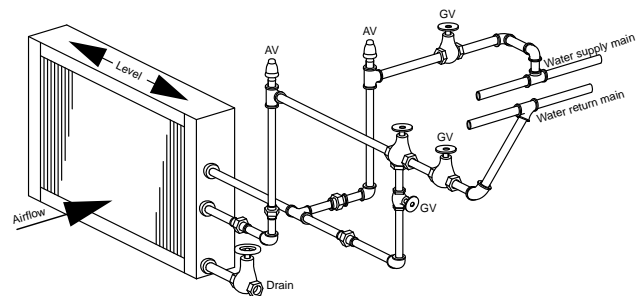


Figure 77. Typical piping for type 5A, 5W two-row, W 3- to 12-row, WD, D1, and D2 water coils

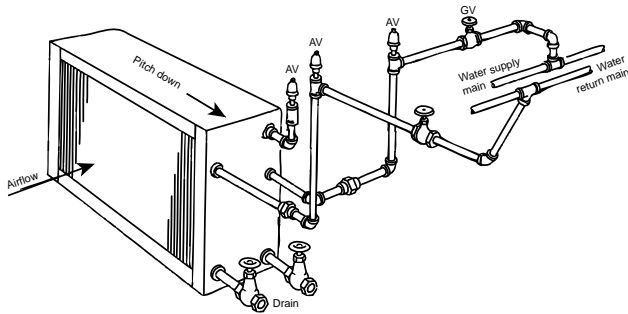
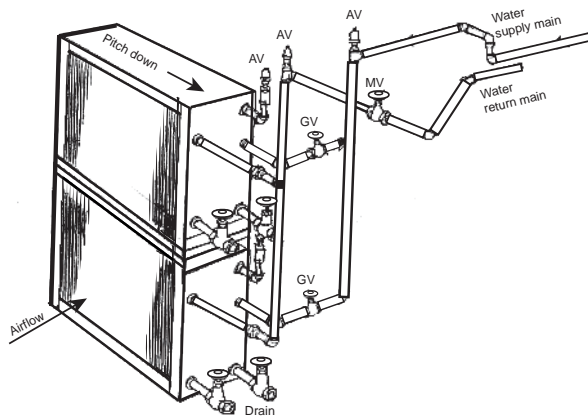


Figure 78. Typical piping for stacked water coils

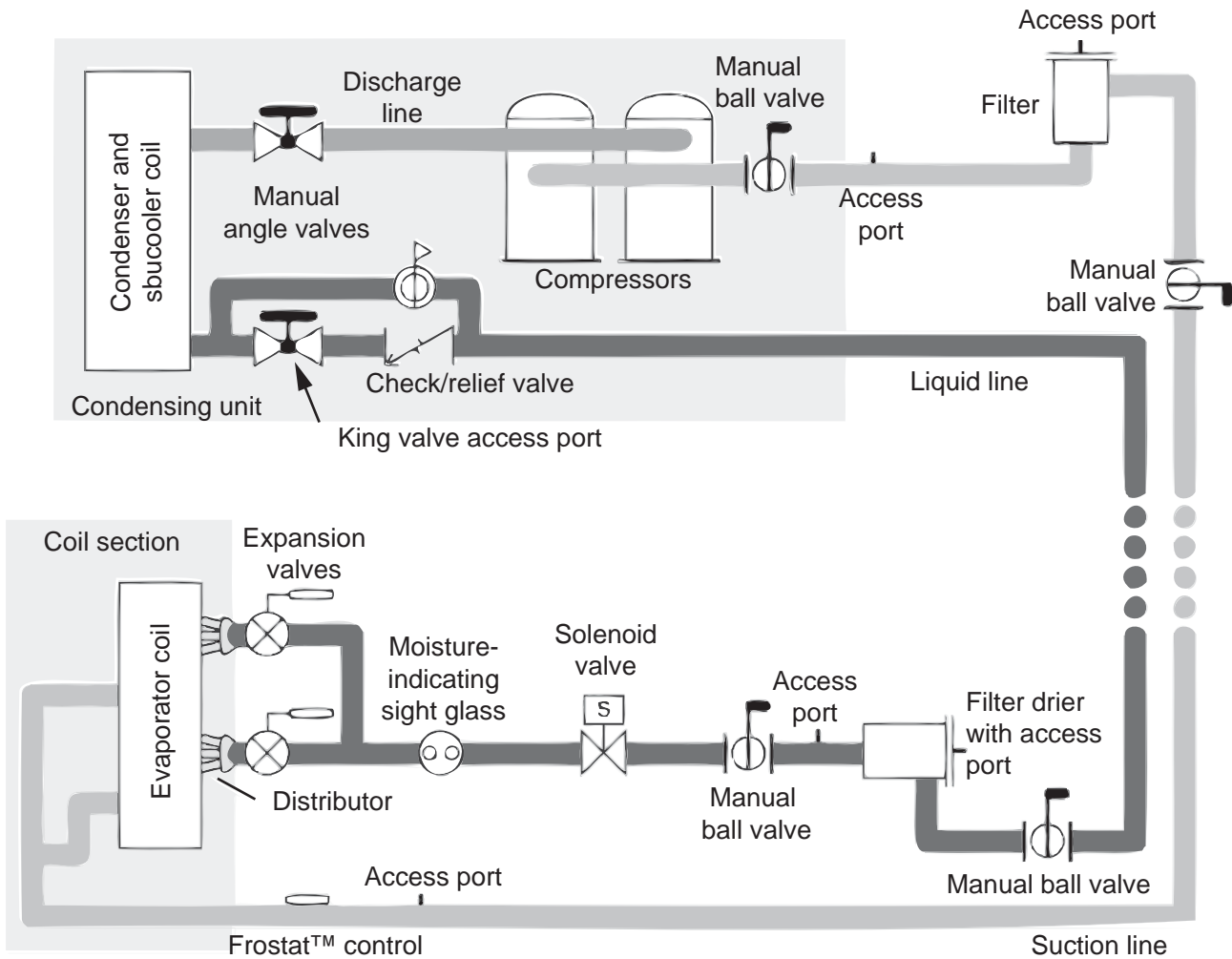


## Refrigerant Coil Piping

**Note:** See the information on handling refrigerants.

Figure 79, p. 62 illustrates an example of a split-system component arrangement. Use it to determine the proper, relative sequence of the components in the refrigerant lines that connect the condensing unit to an evaporator coil. See the “Field-Installed Evaporator Piping,” p. 66 for more detailed schematics of evaporator piping.

**Figure 79. Example of placement for split-system components**



Kit with sensor - X13790452010 SEN-01212  
 Kit with switch - X13100429010 THT 02442

## Liquid Lines

### Line Sizing

Properly sizing the liquid line is critical to a successful split system application. The selected tube diameter must provide at least 5°F [2.7°C] of subcooling at the expansion valve throughout the operating envelope. Increasing the size of the liquid line will not increase the available subcooling.

### Routing

Install the liquid line with a slight slope in the direction of flow so that it can be routed with the suction line. Minimize tube bends and reducers because these items tend to increase pressure drop and to reduce subcooling at the expansion valve. Liquid line receivers, other than those that are factory-installed, are not recommended.

## Insulation

The liquid line is generally warmer than the surrounding air, so it does not require insulation. In fact, heat loss from the liquid line improves system capacity because it provides additional subcooling. However, if the liquid line is routed through a high temperature area, such as an attic or a mechanical room, insulation would be required.

## Components

Liquid-line refrigerant components necessary for a successful job include a filter drier, access port, solenoid valve, moisture indicating sight glass, expansion valve(s), and ball shutoff valves. Figure 79, p. 62 illustrates the proper sequence for positioning them in the liquid line. Position the components as close to the evaporator as possible.

- Filter drier: There is no substitute for cleanliness during system installation. The filter drier prevents residual

contaminants, introduced during installation, from entering the expansion valve and solenoid valve.

- Access port: The access port allows the unit to be charged with liquid refrigerant and is used to determine subcooling. This port is usually a Schraeder® valve with a core.
- Solenoid valve: In split systems, solenoid valves isolate the refrigerant from the evaporator during off cycles; under certain conditions, they may also trim the amount of active evaporator as compressors unload. Generally, the trim solenoid valve is unnecessary for VAV comfort-cooling applications, and is only required for constant-volume applications when dehumidification is a concern. In split systems with microchannel heat exchanger condensers (MCHE), solenoid valves isolate the refrigerant from the evaporator during the off cycles. Trim solenoids cannot be used with MCHE.

**Note:** Trane condensing units with MCHE no longer employ pump-down, but isolation solenoids are required. The suggested solenoid uses a 120-volt service and requires code-compliant wiring to the condensing unit.

- Moisture-indicating sight glass: Be sure to install one moisture-indicating sight glass in the main liquid line. The only value of the sight glass is its moisture indication ability.

Use actual measurements of temperature and pressure not the sight glass to determine subcooling and whether the system is properly charged. The moisture indicator/ sight glass must be sized to match the size of the liquid line at the thermal expansion valve.

### NOTICE

#### Valve Damage!

Failure to protect the valve from high temperatures could result in damage to internal components.

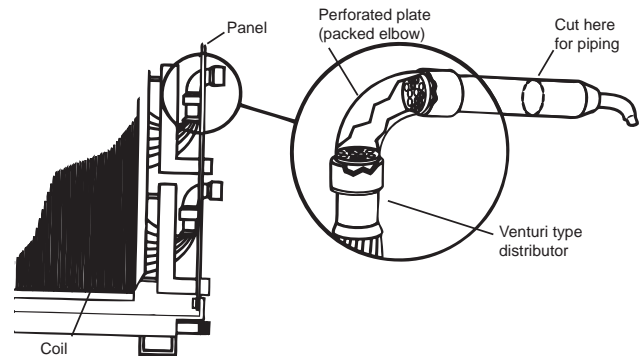
Disassemble the thermal expansion valve before completing the brazing connections. If necessary, wrap the valve in a cool, wet cloth while brazing.

- Thermal expansion valve: The expansion valve is the throttling device that meters the refrigerant into the evaporator coil. Metering too much refrigerant floods the compressor; metering too little elevates the compressor temperature. Choosing the correct size and type of expansion valve is critical to assure it will correctly meter refrigerant into the evaporator coil throughout the entire operating envelope of the system. Correct refrigerant distribution into the coil requires an expansion valve for each distributor.

The thermal expansion valve must be selected for proper size and capacity. The size of the expansion valve should cover the full range of loadings. Check that the valve will successfully operate at the lightest load condition. For improved modulation,

choose expansion valves with balanced port construction and external equalization. Cut the process tube and cap assembly from the liquid connection as shown in Figure 80, p. 63 and install the expansion valve directly to the liquid connections.

**Figure 80. Type F refrigerant coil with packed elbow**



- Ball shutoff valves: Adding manual, ball-type shutoff valves upstream and downstream of the filter simplifies replacement of the filter core.

## Suction Lines

### Line sizing

Proper line sizing is required to guarantee the oil returns to the compressor throughout the systems operating envelope. At the same time, the line must be sized so that the pressure drop does not excessively affect capacity or efficiency. To accomplish both objectives, it may be necessary to use two different line diameters: one for the horizontal run and for the vertical drops, and another for the vertical lifts (risers).

### Routing

To prevent residual or condensed refrigerant from free-flowing toward the compressor during the off cycle, install the suction line so it slopes by 1/4-inch to 1-inch per 10 feet of run toward the evaporator.

When the application includes a suction riser, oil must be forced to travel the height of the riser. Riser traps are unnecessary in the suction line. They will add pressure drop. Double risers must not be used. They not only add pressure drop, but can hold great amounts of oil better used in the compressor.

**Note:** If a suction riser is properly sized, oil will return to the compressor regardless of whether a trap is present. If a suction riser is oversized, adding a trap will not restore proper oil entrainment.

## Avoid Underground Refrigerant Lines

Refrigerant condensation during the off cycle, installation debris inside the line (including condensed ambient



## Piping and Connections

moisture), service access, and abrasion/corrosion can quickly impair reliability.

### Insulation

Any heat that transfers from the surrounding air to the cooler suction lines increases the load on the condenser (reducing the systems air-conditioning capacity) and promotes condensate formation. After operating the system and testing all fittings and joints to verify that the system is leak-free, insulate suction lines to prevent heat gain and unwanted condensation.

### Components

Installing the suction line requires field installation of these components: a filter, access port, and a Froststat™ control when the refrigerant coil is used with Trane condensing units. Position them as close to the compressor as possible.

**Note:** Placement of the Froststat control is illustrated in Figure 79, p. 62.

- Filter: The suction filter prevents contaminants, introduced during installation, from entering the compressor. For this reason, the suction filter should be the replaceable-core type, and a clean core should be installed after the system is cleaned up.
- Access port: The access port is used to determine suction pressure. This port is usually a Schraeder valve with a core.
- Froststat coil frost protection: The Froststat control is the preferred method for protecting evaporator coils from freezing when the refrigerant coil is used with Trane condensing units. It senses the suction-line temperature and temporarily disables mechanical cooling if it detects frost conditions. The control is mechanically attached to the outside of the refrigerant line, near the evaporator, and wired to the unit control panel.
- Ball shutoff valve: Adding manual, ball-type shutoff valves upstream and downstream of the filter simplifies replacement of the filter core.

### Expansion Valves

Expansion valves meter refrigerant into the evaporator under controlled conditions. If there is too much refrigerant, the refrigerant will not completely vaporize and the remaining liquid will slug the compressor. If there is too little refrigerant, there may not be enough cooling for the compressor.

Expansion valve requirements vary based on condensing unit design. Consult the product literature for the condensing unit to be used for proper valve selection.

### Hot Gas Bypass

Many years ago, hot gas bypass (HGBP) was successfully added to HVAC systems to correct a number of operational

problems. Hoping to avoid such problems altogether, it eventually became common practice for designers to specify hot gas bypass in new systems. Unfortunately, the practice often degraded rather than improved reliability.

Hot gas bypass increases the minimum refrigerant charge; it also inflates the first cost of the system. Besides adding more paths for potential refrigerant leaks, hot gas bypass increases the likelihood of refrigerant distribution problems. Finally, hot gas bypass uses excessive amounts of energy by preventing the compressors from cycling with fluctuating loads.

Trane now has many years of experience in the successful use of equipment without hot gas bypass in commercial comfort-cooling applications. To prevent evaporator freeze-up, Trane equipment typically includes Froststat™ coil frost protection.

Like hot gas bypass, the Froststat system protects the coil from freezing, but it does so by turning off compressors when a sensor detects the formation of frost on the evaporator coil. The compressor is released to operate when the coil temperature rises a few degrees above the frost threshold. The Froststat control strategy reduces the overall energy consumption of the system while maintaining system control.

Systems should be designed to avoid HGBP whenever possible. For more information about HGBP, see Engineers Newsletter, *Engineering Newsletter - blessing or curse? Hot Gas Bypass – Engineers Newsletter or Application Note (ADM-APN007\*-EN)*.

## Humidifier Piping and Connections

These instructions cover the piping installation for Trane building steam humidifier panel and atmospheric steam humidifier panel. The humidifier panel shall arrive installed in the unit air cabinet.

Units with a humidifier panel to be used with building (boiler) steam will also receive the following piping accessories shipped direct from the humidifier vendor to the jobsite address.

- Inverted bucket steam trap (to be used to drip steam supply to control valve)
- Control valve
- In-line Y strainer (to be used prior to the control valve)
- Float and thermostatic steam trap (for condensate drainage of header, two required)

Units with a humidifier panel to be used with atmospheric distribution of steam generated by electric or steam-to-steam humidifiers (steam generating) are not supplied with piping accessories. Piping will be determined by requirement of field-provided steam generator.

All accessories listed above will be on the packing slip. Report any shortages immediately. If accessories have been damaged in transit, notify Trane and file claim with the transportation company. If your order covers more than one

package, segregate complete assembly. Equipment tagging will be the same as shown on the packing list.

All piping accessories should be installed in accordance with all applicable building, plumbing, and electrical codes.

Condensate discharged from the humidifier separator/header is essentially atmospheric pressure. Thus condensate must be discharged to a drain or pumped. On many applications, an attempt to lift condensate even a few inches will lead to potential flooding or spitting problems from the multiple tube bank. Avoid combined trapping of the two connections into one steam trap. If traps discharge into a common return, install check valves (low opening pressure) on the outlet of each trap.

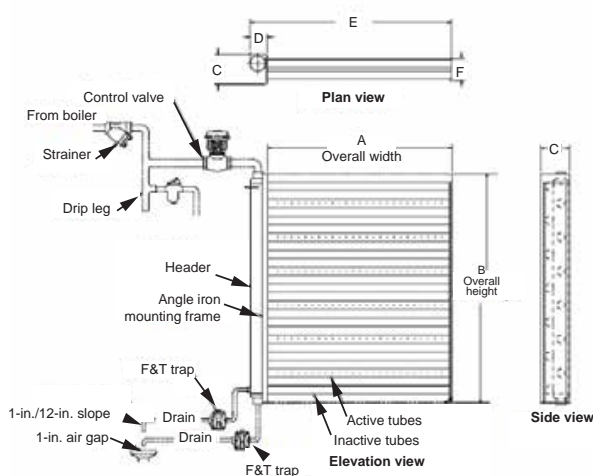
Supplying quality steam (not wet) to the humidifier panel is an important component for proper operation. Care must be taken that the main supply header is dripped sufficiently as well as the runout piping to the control valve and header. The entire system must be designed and hooked up to prevent accumulation of condensate at any point. The following recommendations will help to ensure this.

Use drip legs and traps at all low spots or natural drainage points such as:

- Ahead of risers
- End of mains
- Ahead of expansion joints or bends
- Ahead of valves or regulators

Install drip legs and drain traps even where there are no natural drainage points.

**Figure 81. Building (boiler) steam panel piping**



## Remodel, Retrofit, or Replacement

Inevitably, older condensing units and evaporator systems will need to be replaced or retrofitted. Due to the phase-out of many of these older refrigerants, the major components for those older units or systems may no longer be

available. The only option will be to convert the system to R-410A, POE oil, and R-410A components.

When upgrading an existing refrigerant split system due to remodel, retrofit, or replacement, the entire system must be reviewed for compatibility with R-410A and POE oil. Each and every part of the split HVAC system **MUST** be compatible with the properties of R-410A refrigerant and POE oil. In addition, ensure the existing electrical service is adequate for the product being installed.

**⚠ WARNING**

**R-410A Refrigerant under Higher Pressure than R-22!**

**Failure to use proper equipment or components as described below, could result in equipment failing and possibly exploding, which could result in death, serious injury, or equipment damage.**

**The units described in this manual use R-410A refrigerant which operates at higher pressures than R-22. Use ONLY R-410A rated service equipment or components with these units. For specific handling concerns with R-410A, please contact your local Trane representative.**

Every part of an existing split system needs to be analyzed to determine if it can be reused in an R-410A and POE oil system:

- R-22 condensing units will not work with R-410A; they must be replaced.
- Most older evaporator coils were not pressure- and cyclered for R-410A pressures. If they weren't, they will need to be replaced. If they were properly pressure-rated for R-410A, existing coils must be modeled to determine if they will meet capacity requirements, are properly circuited, have correctly sized distributor tubes, and employ acceptable distributors and orifices.
- The required R-410A line sizes may be different than the existing line sizes. The lines need to be re-sized and compared to existing lines for reusability.
- Suction lines 2-5/8 OD and smaller of type L copper are suitable for use with R-410A. Suction lines 3-1/8 OD must use type K or thicker wall.
- Discharge lines, liquid lines, heat pump vapor lines, and hot gas bypass lines 1-3/8 OD and smaller of type L copper are suitable for use with R-410A. These same lines sized at 1-5/8 OD or 2-1/8 OD must use type K or thicker wall.
- Expansion valves need to be reselected. Expansion valves are refrigerant specific.
- Any gasket or O-ring should be replaced. Shrinkage of the original seal may occur after an HFC conversion, potentially causing a refrigerant leak. Components commonly affected are Schraeder cores, solenoid valves, ball valves, and flange seals. But all external seals in contact with refrigerant should be viewed as potential leak sources after a retrofit.

## Piping and Connections

- All other valves, filters, valve packing, pressure controls, and refrigeration accessories must be researched through their manufacturer for compatibility with the pressures of an R-410A system, and for their compatibility with the newer POE oil.
- For the best performance and operation, the original mineral oil should be removed from the components of the system that are not being replaced. Any component of the system that is suspected of trapping oil (piping, traps, and coil), should be dismantled, drained, and reassembled. After all components have been drained, the amount of residual mineral oil will have a negligible effect on performance and reliability

### NOTICE

#### Compressor Damage!

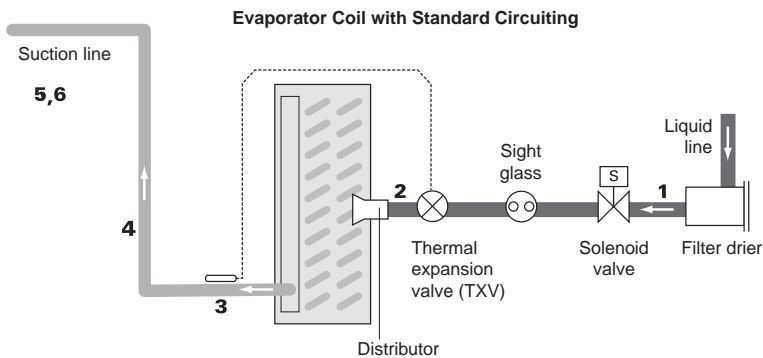
POE oil is hygroscopic – it absorbs water directly from the air. This water is nearly impossible to remove from the compressor oil and can result in compressor failures.

To prevent POE oil from absorbing water, the system should not remain open for longer than necessary. When open, dry nitrogen should flow through the piping. Only new oil containers should be used for service and maintenance. Always use the smallest container size required for the job requirements. Always leave the oil container tightly sealed until time of use. Do not reuse oil that has been opened.

All Codes take precedence over anything written here.

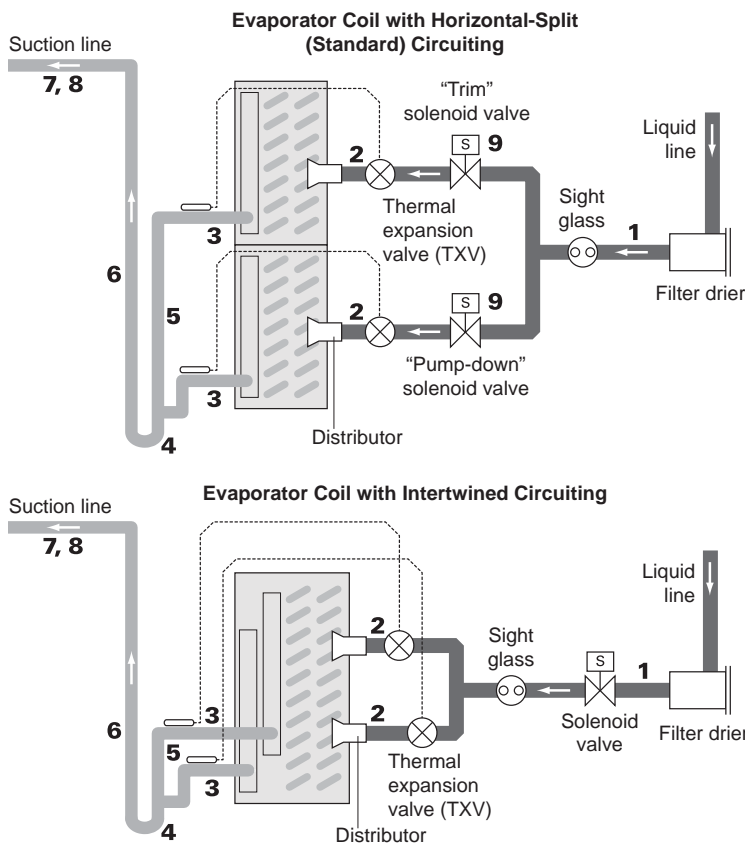
## Field-Installed Evaporator Piping

**Figure 82. Typical single-circuit condensing unit: evaporator coil with one distributor**



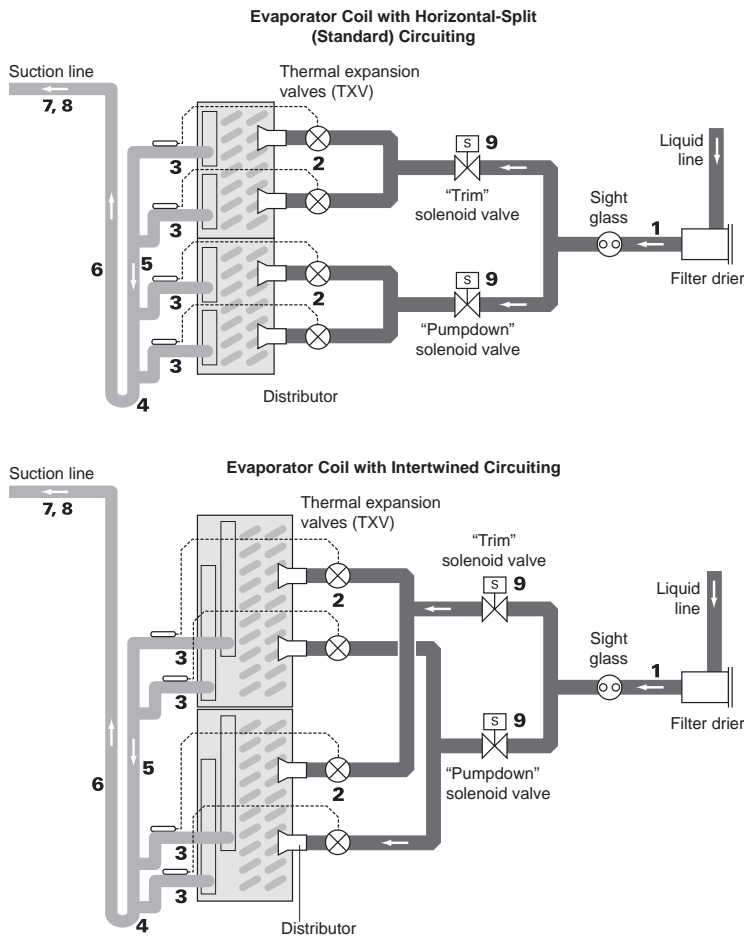
1. Pitch the liquid line slightly – 1 inch/10 feet – so that the refrigerant drains toward the evaporator.
2. Provide one expansion valve per distributor.
3. Slightly pitch the outlet line from the suction header toward the suction riser – that is, 1 inch/10 feet in the direction of flow. Use the tube diameter that matches the suction header connection.
4. Use the tube diameter recommended in the condensing unit application manual for a vertical rise. Ensure that the top of the riser is higher than the evaporator coil
5. Pitch the suction line slightly – 1 inch/10 feet – so the refrigerant drains toward the evaporator.
6. Insulate the suction line.

**Figure 83. Typical single-circuit condensing unit: evaporator coil with two distributors**



1. Pitch the liquid line slightly – 1 inch/10 feet – so the refrigerant drains toward the evaporator.
  2. Provide one expansion valve per distributor.
  3. Slightly pitch the outlet line from the suction header toward the suction riser – 1 inch/10 feet in the direction of flow. Use the tube diameter that matches the suction-header connection. Use a double-elbow configuration to isolate the TXV bulb from other suction headers.
  4. This looks like a trap, but is actually due to the requirement that the refrigerant gas leaving the coil flows downward, past the lowest suction-header outlet, before turning upward.
  5. Use the **horizontal** tube diameter as specified in the condensing unit application manual.
  6. Use the tube diameter recommended for a vertical rise as specified in the condensing unit application manual. Assure the top of the riser is higher than the evaporator coil.
  7. Pitch the suction line slightly – 1 inch/10 feet – so that the refrigerant drains toward the evaporator.
  8. Insulate the suction line.
  9. Only use a **trim** solenoid valve for constant volume, humidity-sensitive applications. For all other applications, install a single solenoid valve (the **pumpdown** solenoid valve) between the liquid-line filter drier and the sight glass.
- Note:** Due to reduced coil volume in condensing units with microchannel heat exchanger condenser, do not use trim solenoid valves for these units.

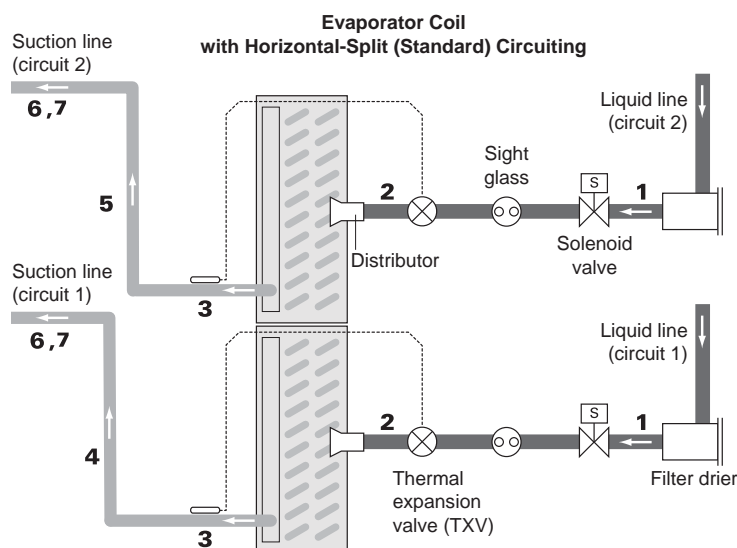
**Figure 84. Typical single-circuit condensing unit: evaporator coil with four distributors**



1. Pitch the liquid line slightly – 1 in./10 feet – so that the refrigerant drains toward the evaporator.
2. Provide one expansion valve per distributor.
3. Slightly pitch the outlet line from the suction header toward the suction riser – 1 in./10 feet in the direction of flow. Use the tube diameter that matches the suction-header connection.
4. This looks like a trap, but is actually due to the requirement that the refrigerant gas leaving the coil flows downward, past the lowest suction-header outlet, before turning upward. Use the double-elbow configuration to isolate the TXV bulb from other suction headers.
5. Use the **horizontal** tube diameter as specified in the condensing unit application manual.
6. Use the tube diameter recommended for a vertical rise as specified in the condensing unit application manual. Ensure that the top of the riser is higher than the evaporator coil.
7. Pitch the suction line slightly – 1 in./10 feet – so that the refrigerant drains toward the evaporator.
8. Insulate the suction line.
9. Only use a **trim** solenoid valve for constant volume, humidity-sensitive applications. For all other applications, install a single solenoid valve (the **pumpdown** solenoid valve) between the liquid-line filter drier and the sight glass.

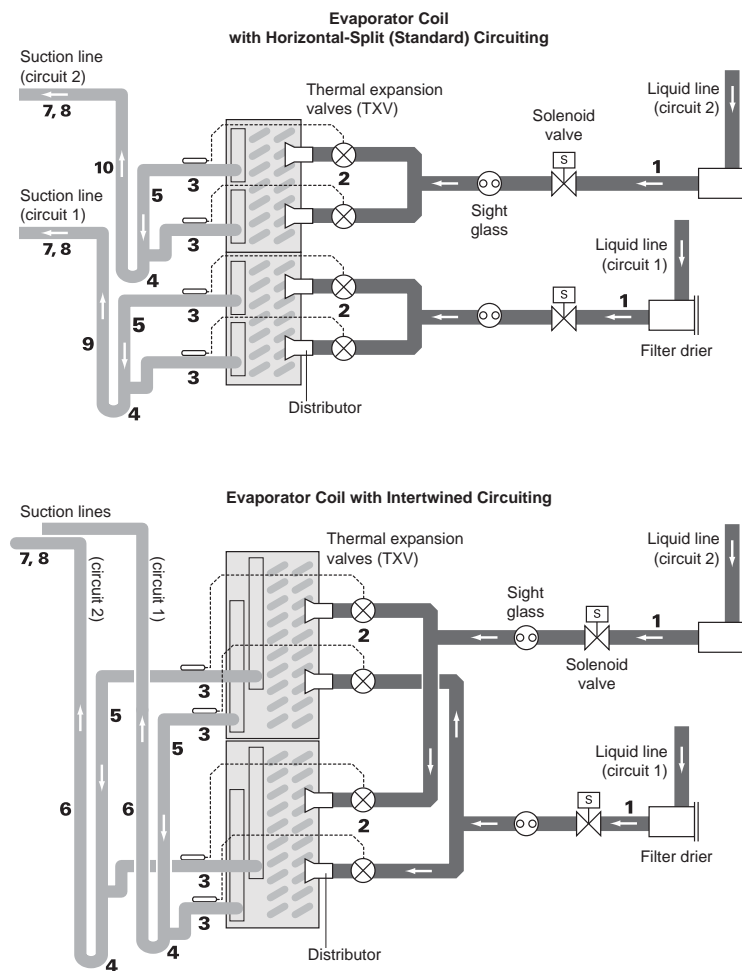
**Note:** Due to reduced coil volume in condensing units with microchannel heat exchanger condenser, do not use trim solenoid valves for these units.

**Figure 85. Typical dual-circuit condensing unit: evaporator coil with two distributors**



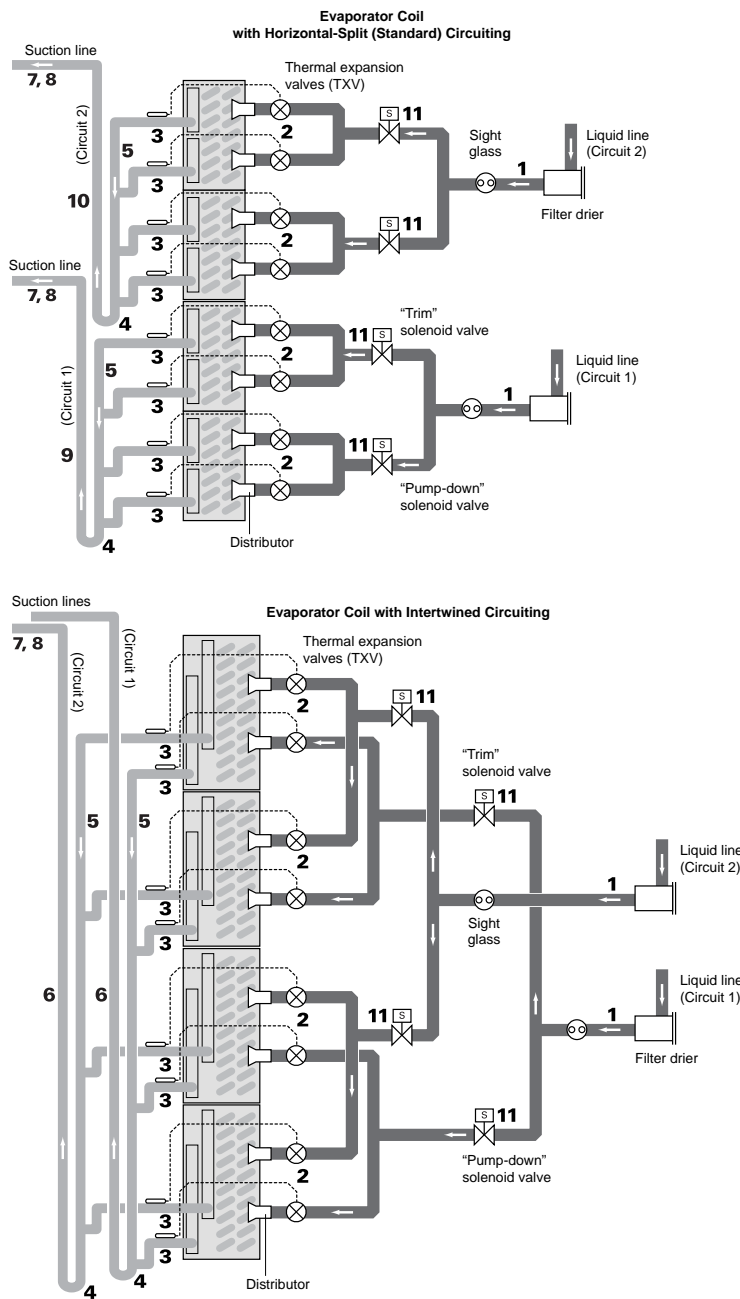
1. Pitch the liquid lines slightly – 1 in./10 feet – so that the refrigerant drains toward the evaporator.
2. Provide one expansion valve per distributor.
3. Slightly pitch the outlet line from the suction header toward the suction riser – 1 in./10 feet in the direction of flow. Use the tube diameter that matches the suction-header connection.
4. The top of the Circuit 1 suction riser must be higher than the bottom evaporator coil. Use the tube diameter recommended for a vertical rise as specified in the condensing unit application manual.
5. The top of the Circuit 2 suction riser must be higher than the top evaporator coil. Use the tube diameter recommended for a vertical rise as specified in the condensing unit application manual.
6. Pitch the suction lines slightly – 1 in./10 feet – so that the refrigerant drains toward the evaporator.
7. Insulate the suction lines.

**Figure 86. Typical dual-circuit condensing unit: evaporator coil with four distributors**



1. Pitch the liquid line slightly – 1 in./10 feet – so that the refrigerant drains toward the evaporator.
2. Provide one expansion valve per distributor.
3. Slightly pitch the outlet line from the suction header toward the suction riser – 1 in./10 feet in the direction of flow. Use the tube diameter that matches the suction-header connection.
4. This looks like a drain trap, but is actually due to the requirement that the refrigerant gas leaving the coil flows downward, past the lowest suction-header outlet, before turning upward. Use the double-elbow configuration to isolate the TXV bulb from other suction headers.
5. Use the **horizontal** tube diameter as specified in the condensing unit application manual.
6. Use the tube diameter recommended for a vertical rise as specified in the condensing unit application manual. Ensure that the top of the riser is higher than the evaporator coil.
7. Pitch the suction line slightly – 1 in./10 feet – so that the refrigerant drains toward the evaporator.
8. Insulate the suction line.
9. The top of the Circuit 1 suction riser must be higher than the bottom evaporator coil. Use the tube diameter recommended for a vertical rise as specified in the condensing unit application manual.
10. The top of the Circuit 2 suction riser must be higher than the top evaporator coil. Use the tube diameter recommended for a vertical rise as specified in the condensing unit application manual.

**Figure 87. Typical dual-circuit condensing unit: evaporator coil with eight distributors**



1. Pitch the liquid line slightly – 1 inch/10 feet – so that the refrigerant drains toward the evaporator.
2. Provide one expansion valve per distributor.
3. Slightly pitch the outlet line from the suction header toward the suction riser – 1 in./10 feet in the direction of flow. Use the tube diameter that matches the suction-header connection.
4. This looks like a drain trap, but is actually due to the requirement that the refrigerant gas leaving the coil flows downward, past the lowest suction-header outlet, before turning upward. Use the double-elbow configuration to isolate the TXV bulb from other suction headers.
5. Use the **horizontal** tube diameter as specified in the condensing unit application manual.
6. Use the tube diameter recommended for a vertical rise as specified in the condensing unit application manual. Confirm that the top of the riser is higher than the evaporator coil.
7. Pitch the suction line slightly – 1 in./10 feet – so that the refrigerant drains toward the evaporator.
8. Insulate the suction line.
9. The top of the Circuit 1 suction riser must be higher than the bottom evaporator coil. Use the tube diameter recommended for a vertical rise as specified in the condensing unit application manual.
10. The top of the Circuit 2 suction riser must be higher than the top evaporator coil. Use the tube diameter recommended for a vertical rise as specified in the condensing unit application manual.
11. Only use a **trim** solenoid valve for constant volume, humidity-sensitive applications. For all other applications, install a single solenoid valve (the **pumpdown** solenoid valve) between the liquid-line filter drier and the sight glass.

**Note:** Due to reduced coil volume in condensing units with microchannel heat exchanger condenser, do not use trim solenoid valves for these units.

# Installation – Electrical

## ⚠ WARNING

### Hazardous Voltage w/Capacitors!

Failure to disconnect power and discharge capacitors before servicing could result in death or serious injury.

Disconnect all electric power, including remote disconnects and discharge all motor start/run capacitors before servicing. Follow proper lockout/tagout procedures to ensure the power cannot be inadvertently energized. For variable frequency drives or other energy storing components provided by Trane or others, refer to the appropriate manufacturer's literature for allowable waiting periods for discharge of capacitors. Verify with a CAT III or IV voltmeter rated per NFPA 70E that all capacitors have discharged.

## ⚠ WARNING

### Electrical Shock Hazard!

Failure to follow instructions below could result in death or serious injury.

Properly connect the system's oversized protective earthing (grounding) terminal(s).

## NOTICE

### Use Copper Conductors Only!

Failure to use copper conductors could result in equipment damage as the equipment was not designed or qualified to accept other types of conductors.

*Note: Air handlers often include optional factory-provided casing penetration entry points for field-provided wiring. Consider overall unit serviceability and accessibility before mounting, running wires (power), making cabinet penetrations, or mounting any components to the cabinet.*

Units intended for indoor use are available with variable frequency drives (VFDs) that are externally mounted in an enclosure or internally mounted in a recessed cabinet. Units intended for outdoor use are only available with internally mounted VFDs. A typical internally mounted VFD is shown in [Figure 88, p. 71](#).

Figure 88. Internally mounted VFD



A typical externally mounted VFD is shown in [Figure 89, p. 71](#).

Figure 89. Externally mounted VFD



A typical wiring schematic for a VFD is shown in [Figure 95, p. 74](#). Unit specific wiring schematics are shipped with each unit.

All units with VFDs that have direct-digital controllers (DDCs) are provided with line voltage to 24 Vac power transformers as shown in [Figure 90, p. 72](#).

**Figure 90. Controller - internally mounted**

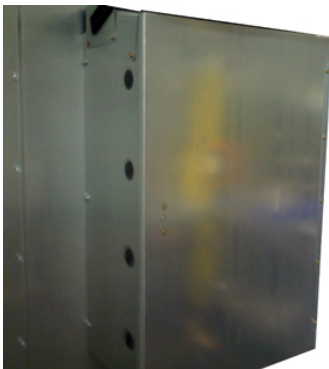


When provided, the line voltage to 24 Vac transformers are factory wired to the supply fan power feed. All units with factory-mounted controllers, and no VFDs, are provided with 120 Vac to 24 Vac control transformers, as shown in [Figure 91, p. 72](#), and require a separate 120 V field connection.

**Figure 91. Controller - externally mounted**



**Figure 92. Externally mounted control box**



As with VFDs, units intended for indoor use are available with DDCs mounted internally (see [Figure 88, p. 71](#)) or externally (see [Figure 91, p. 72](#) and [Figure 92, p. 72](#)), while units intended for outdoor use are only available with internally mounted DDCs.

In units with 24 Vac LED marine lights, the lights are wired together to a single switch located in the controls interface module. [Figure 86](#) shows a typical mounting of the controls

interface module with an externally mounted controller. When DDCs are provided, the lighting circuit is powered from the DDC power feed and does not require a separate power source. When marine lights are provided without DDCs, the lighting circuit requires a separate 120V field connection that powers the lights through a 120V to 24 Vac power transformer.

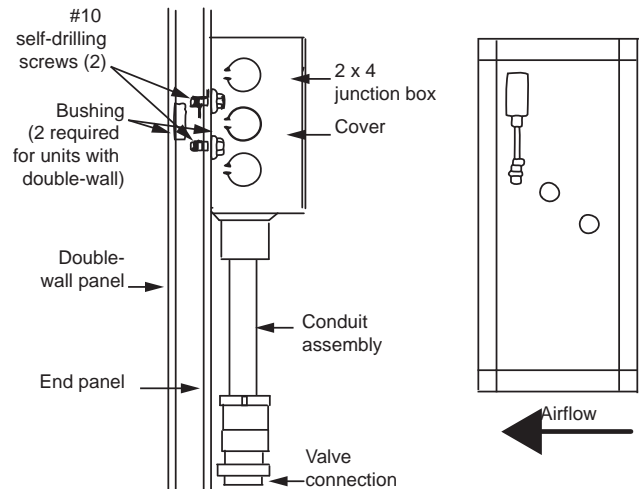
A mounted GFCI receptacle is provided for all units that have DDCs or marine lights. The receptacle is mounted in the controls interface module (see [Figure 86](#)) with the unit light switch. The receptacle requires a separate 120V power feed.

The electric heat door may have a solenoid locking mechanism to prevent opening the control panel while the electric heater is energized.

Field installed DDC control devices:

- Install outside-air sensor and space sensor, if ordered.
- Connect control valves, if ordered, to the valve jack provided as part of the unit wiring harness. The valve jack is typically located at the air-leaving side of the coil connection inside the casing panel. For valve junction box mounting and wiring detail, see [Figure 93, p. 72](#).

**Figure 93. Junction box for valve wiring**



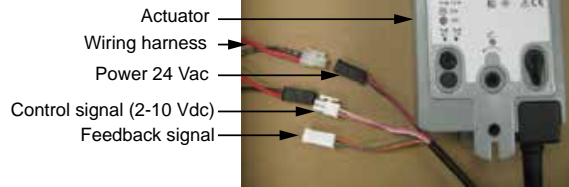
## Quick Connects

The actuators, factory-mounted or field-supplied, are separately wired and controlled by a direct-digital controller or other building logic. [Figure 94, p. 73](#) illustrates the typical quick connect scheme.

**Note:** *With units that require splits to be assembled that have high voltage quick connects, use wire ties to bind the quick connections together to avoid poor connections or intermittent connection from vibrations.*

**Figure 94. Typical quick connects with wiring**

Wiring:  
 Red/black - power (hot)  
 White/pink - control signal (in)  
 Orange/gray - feedback (out)



If the unit does not include a factory-mounted VFD, wiring to the unit fan motor must be provided by the installer and must comply with all national and local electrical codes. The installer must also furnish a service disconnect switch in compliance with national and local electrical codes.

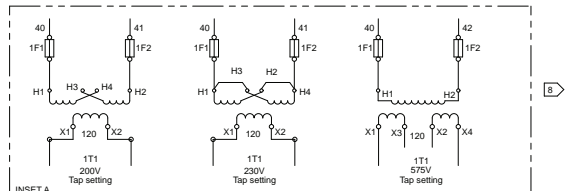
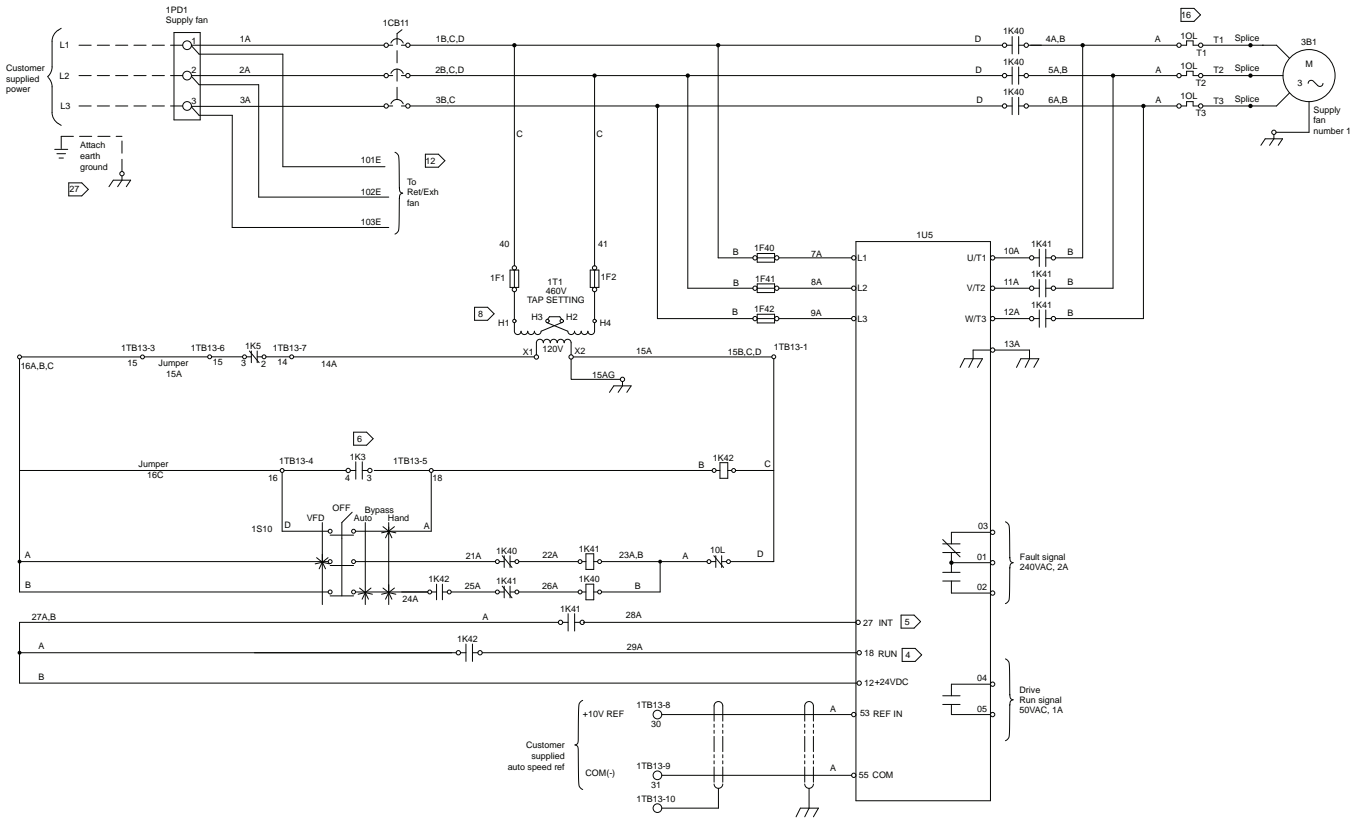
Fan motors require motor overload protective devices that are rated or selected in compliance with the National Electric Code (NEC) or Canadian Electric Code. Specific unit and motor connection diagrams are provided on the VFD if Trane provided, or refer to the motor nameplate.

Fractional horsepower motors may be factory connected to a terminal box on the unit. If this construction is provided, the installer should complete field wiring to this connection box. For a typical high voltage wiring schematic, see [Figure 95, p. 74](#).

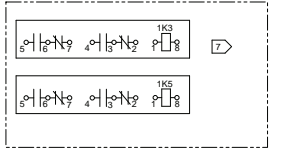
**Note:** *Properly seal all penetrations in unit casing. Failure to seal penetrations from inner panel to outer panel could result in unconditioned air entering the unit.*

# Typical Wiring Schematics

Figure 95. Typical VFD wiring schematic



Busman Class T Drive AFC Fuse	Voltage	HP	Part No.
200/230	1.1, 5	JUN-10	
	2	JUN-15	
	3	JUN-20	
	5	JUN-25	
	7.5	JUN-30	
	10	JUN-50	
	15	JUN-60	
	20	JUN-80	
	25, 30	JUN-125	
	40	FWH-150B	
460	50	FWH-200B	
	1.1, 5	JJS-6	
	2.3	JJS-10	
	5	JJS-20	
	7.5	JJS-25	
	10	JJS-30	
	15, 20	JJS-40	
	25	JJS-50	
	30	JJS-60	
	40	JJS-80	
575	50	JJS-100	
	60	JJS-125	
	75	FWH-150B	
	100	FWH-200B	
	125	FWH-250B	
	1.1, 5	JJS-3	
	2.3	JJS-4	
	5, 7.5	JJS-10	
	10	JJS-15	
	15	JJS-20	
20	JJS-30		
25	JJS-35		
30	JJS-45		
40	JJS-60		
50	JJS-80		
60	JJS-90		
75	JJS-100		
100	FWP-125A		
125	FWP-175B		



Fuse Rating (AMPS) - 600V Class LP-CC Time Delay				
Line	Item	MFR.	MFR. Part NO.	Danfloss NO.
200	1F1, 1F2	Busman	FNQ-R-1.25	34046200
230	1F1, 1F2	Busman	FNQ-R-1.25	34046200
460	1F1, 1F2	Busman	FNQ-R-0.69	34046200
575	1F1, 1F2	Busman	FNQ-R-0.50	34053600

Device Prefix Location Code	
Area	Location
1	High voltage panel
2	Low voltage panel (Unit schematic)
3	Air handler section

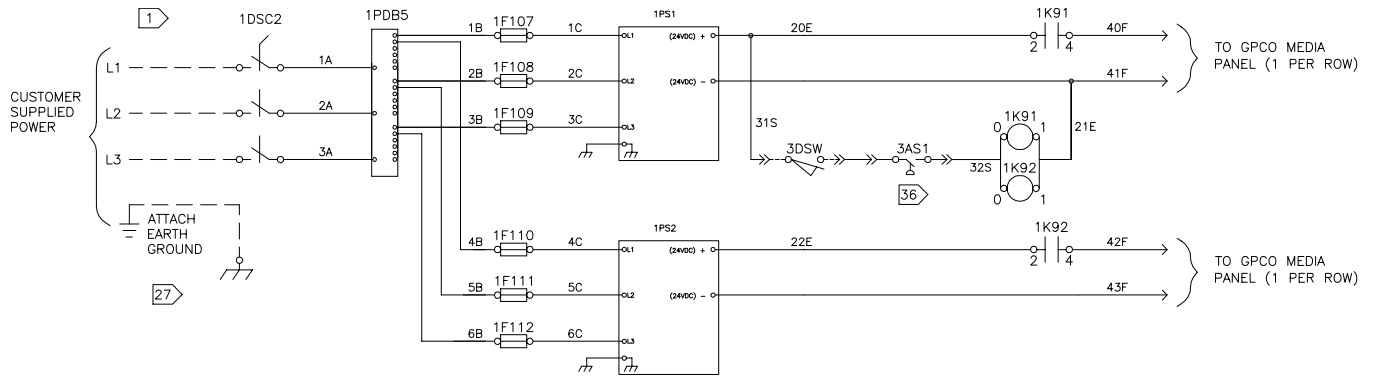
Device Designation	Description
1CB11	VFD circuit breaker
1F1, 1F2	Control circuit primary fuse(s)
1F40, 1F41, 1F42	AFC fuse(s)
1K3	Supply fan start/stop relay
1K5	Supply fan low limit relay
1K40	Bypass contactor
1K41	Isolation contactor
1K42	Run permissive relay
1OL	Overload relay
1S10	VFD OFF/Bypass Auto/Bypass hand switch
1PD1	Supply fan power distribution block
1TB13	Terminal strip control circuit
1U5	Drive controller (AFC)
3B1	Supply fan motor

- Notes:
- Dashed lines indicate recommended field wiring by others. Phantom lines indicate control option. Ref. Control panel schematic for specific detail.
  - All field wiring must be in accordance with the National Electrical Code (NEC), state and local requirements. Other countries applicable national and/or local requirements shall apply. Field conductors shall have insulation rating not less than 600V copper conductors only.
  - The minimum circuit ampacity, the maximum fuse size, and disconnect size are calculated based on the inverter input line currents per article 430-2 of the National Electrical Code.
  - Program terminal 18 as run.
  - Program terminal 27 inv. coasting stop.
  - Closes to run auto mode or bypass auto for option VFD or starter.
  - Relay(s)—contacts: silver-cadmium oxide: 1/8 hp 5 amp @ 120V AC, 1/3 hp 5 amp @ 240V AC. See 24V schematic diagram for coil connections and actual quantity of transformer relays.
  - Control transformer shown for 460V primary. For 200 or 230V or 575V refer to Inset A.
  - If unit has shipping splits wiring will terminate to module at each shipping split.
  - The overload relay trip setting must be adjusted to correspond with the motor full load current as shown on the motor nameplate.
  - Attach ground or equipment ground.





**Figure 98. Schematic for typical Trane commercial air purification system (TCAPS)**



POWER SUPPLY FUSES			
FUSE	VOLTAGE	POWER SUPPLY(W)	P/N CLASS
1F107	115-230	120	LP-CC-6 CC
1F108		240	LP-CC-10 CC
1F109		480	LP-CC-10 CC
1F110	460-575	960	LP-CC-10 CC
1F111		120	LP-CC-6 CC
1F112		240	LP-CC-6 CC
		480	LP-CC-6 CC
		960	LP-CC-8 CC

DEVICE PREFIX LOCATION CODE	
AREA	LOCATION
1	HIGH VOLTAGE PANEL
2	LOW VOLTAGE PANEL (UNIT SCHEMATIC)
3	AIR HANDLER SECTION

LEGEND	
DEVICE DESIGNATION	DESCRIPTION
1DSC2	PANEL DISCONNECT
1F107 TO 1F112	POWER SUPPLY FUSES
1K91-1K92	CUTOUT RELAY
1PDB5	POWER DISTRIBUTION BLOCK
1PS1	DC POWER SUPPLY
3AS1	AIR PROVING SWITCH
3DSW	DOOR SWITCH

**NOTES:**

- DASHED LINES INDICATE RECOMMENDED FIELD WIRING BY OTHERS. PHANTOM LINES INDICATE CONTROL OPTION. REF. CONTROL PANEL SCHEMATIC FOR SPECIFIC DETAIL.
- ALL FIELD WIRING MUST BE IN ACCORDANCE WITH THE NATIONAL ELECTRICAL CODE, STATE, AND LOCAL REQUIREMENTS. OTHER COUNTRIES APPLICABLE NATIONAL AND/OR LOCAL REQUIREMENTS SHALL APPLY. FIELD CONDUCTORS SHALL HAVE INSULATION RATING NOT LESS THAN 600V COPPER CONDUCTORS ONLY.
- MINIMUM CIRCUIT AMPACITY, MAXIMUM FUSE SIZE, AND DISCONNECT SIZE ARE CALCULATED BASED ON THE INVERTER INPUT LINE CURRENTS PER ARTICLE 430-2 OF THE NATIONAL ELECTRICAL CODE.
- ATTACH GROUND OR EQUIPMENT GROUND.
- AIR PROVING SWITCH FOR CIRCUIT CUTOFF.

# Controls Interface

## Leak Detection Programming

Unit shall be furnished with a leak detection system from the factory. The leak detection system shall consist of one or more refrigerant detection sensors. When the system detects a leak, the unit controller shall initiate mitigation actions. See “A2L Application Considerations,” p. 17.

Factory-installed Symbio™ 500 controllers are programmed with leak detection sequence of operations at the factory.

Field-installed unit controllers require field programming of the leak detection sequence of operations by the controls contractor.

Factory-installed digital terminal blocks, which use an unprogrammed Symbio™ 500 controller, require field programming of the leak detection sequence of operations by the controls contractor.

See UL 60335–2–40 for more information.

## Operator Display

The portable operator display is used for temporary connection to and operation of Trane Symbio™ controller. With the portable operator display, you can monitor data, change setpoints, monitor alarms, and override points. The portable operator display includes a 10 ft (3 m) cable with connector that is stored in the storage compartment of the carrying bag. The cable cannot be disconnected from the operator display. Keep this document with the portable operator display for access to calibration and cleaning instructions.

**Note:** *The portable operator display is not used for timeclock scheduling. To provide scheduling you must use a Tracer Summit system*

## Connecting the Operator Display

To connect the portable operator display:

1. Locate the factory-provided service module (see [Figure 99, p. 78](#)).
2. Attach the operator-display cable to the operator-display connector on the service module. The operator display receives power from the controller and turns on automatically when it is connected.

**Figure 99. Service module**



### NOTICE

#### Display Damage!

Failure to follow instructions below could result in damage to the display.

Use a cloth dampened with commercial liquid glass cleaner to clean the operator display. Do not spray water or cleaner directly on screen.

## Calibrating the Operator Display

This section shows how to calibrate the operator display touch screen and how to adjust the brightness and contrast. To set up the operator display screens and security, see *Tracer® TD-7 Display for the Tracer UC600 Programmable Controller, Tracer UC800 Controller, Symbio 500 Programmable Controller, Symbio 800 Programmable Controller Installation Instructions (BAS-SVN112\*-EN)*.

To calibrate the operator display:

1. On the home screen, press Setup. The Setup menu appears.
2. Page down to view the next screen.
3. Press Calibrate Touch Screen. A calibration screen appears.

### NOTICE

#### Equipment Damage!

Failure to follow instructions below could result in equipment damage.

Protect operator display from contact with sharp objects.

4. Touch the target using a small, pliable, blunt object, such as a pencil eraser or your finger. Hold until the beeping stops. A second calibration screen appears.
5. Again, touch the target with the object. Hold until the beeping stops. The Advanced Selection screen appears.

6. Press Home. The home screen appears.

## Adjusting Brightness and Contrast

To adjust the brightness and contrast of the operator display:

1. On the home screen, press Setup. The Setup menu appears.
2. Page down to view the next screen.
3. Press the Adjust Brightness and Contrast buttons. The Brightness and Contrast screen appears.
4. To increase the brightness, press the buttons along the top row, in sequence, from left to right. To decrease the brightness, press the buttons from right to left.

**Note:** *Contrast adjustment is not available on all computer display models.*

5. To increase the contrast, press the buttons along the bottom row, in sequence, from left to right. To decrease the contrast, press the buttons from right to left.
6. Press Home. The home screen appears.

## External Communications Port

Units with a factory-provided DDC controller can include a service module with an external communications port when purchased. Both the operator display and Tracer® TU service tool can be connected without shutting off the unit through the external communications port. Open the cover plate on the service module and plug into the RJ-45 port for the operator display or the USB port for the Tracer TU service tool. This enables continuous operation of the air handler without disruption to the operating conditions of the unit. When servicing of the unit is complete, close the cover plate on the service module to eliminate any air leakage path.



# Start-Up

## Pre-Startup Checklist

Once the air handler has been assembled and installed, attention must be directed to individual components for proper operation. Before operating the unit, complete the pre-startup checklist.

### **⚠ WARNING**

#### **Hazardous Voltage w/Capacitors!**

Failure to disconnect power and discharge capacitors before servicing could result in death or serious injury.

Disconnect all electric power, including remote disconnects and discharge all motor start/run capacitors before servicing. Follow proper lockout/tagout procedures to ensure the power cannot be inadvertently energized. For variable frequency drives or other energy storing components provided by Trane or others, refer to the appropriate manufacturer's literature for allowable waiting periods for discharge of capacitors. Verify with a CAT III or IV voltmeter rated per NFPA 70E that all capacitors have discharged.

## General Checks

- Ensure the unit has been installed level.
- Ensure supply-air and return-air ducts have been connected.
- Ensure damper operator motors and connecting linkage have been installed.
- Verify damper operation and linkage alignment.
- Check that air filters are in place and positioned properly.
- Remove any debris from the unit interior.
- Remove all foreign material from the drain pan and check drain pan opening and condensate line for obstructions.
- Close and secure all unit access doors.
- If differential pressure switch is provided on filter rack, adjust per system requirements.
- Inspect electrical connections to the unit
  - Connections should be clean and secure.
  - Compare the actual wiring with the unit diagrams.
- Check piping and valves for leaks. Open or close the valves to check for proper operation. Drain lines should be open.
- Leave this manual with the unit.

## Fan-Related Checks

- If the unit is not externally isolated, ensure that the fan isolator tie-down bolts have been removed. See "Fan Isolation," p. 52 for more information.
- Rotate all fan wheels manually to confirm they turn freely in the proper direction.
- Inspect fan motor and bearings for proper lubrication.

## Coil-Related Checks

### **NOTICE**

#### **Proper Water Treatment Required!**

The use of untreated or improperly treated water could result in scaling, erosion, corrosion, algae or slime.

Use the services of a qualified water treatment specialist to determine what water treatment, if any, is required. Trane assumes no responsibility for equipment failures which result from untreated or improperly treated water, or saline or brackish water.

- Ensure coil and condensate drain piping connections are complete.
- Check the piping and valves for leaks.
  - Open or close the valves to check operation.
  - The drain lines should be open.
- If unit has a refrigerant coil, ensure that it has been charged and leak-tested according to the instructions provided with the condenser equipment. Adjust the superheat setting.
- Remove all foreign material from the drain pan and check the pan opening and condensate line for obstructions.
- For steam coils, slowly turn the steam on full for at least 10 minutes before opening the fresh air intake on units with fresh air dampers.

## Motor-Related Checks

- Locate installation manual from the motor manufacturer for the specific motor installed. This can be found by contacting the motor manufacturer's representative. The motor manufacturer's recommendations take precedence for all matters related to the start-up and routine maintenance of the motor.
- For supply fan motor, check the motor lubrication for moisture and rust.
  - Remove and clean grease plugs to inspect.
  - If moisture is present, consult an authorized repair shop for bearing inspection/replacement. This may require removal and transport of motor.

- If no moisture is present, refer to the motor manufacturer's lubrication recommendations for proper lubrication.
- The motor manufacturer may recommend lubricating the motor as part of their routine start-up instructions.
- Check motor winding. An acceptable winding resistance reading is from 6 meg-ohms to infinity. If reading is less than 5 mega-ohms, the winding should be dried out in an oven or by a blower.
- Inspect the entire motor for rust and corrosion.
- Bump-start the unit and confirm the fan wheel rotates properly, as indicated by the rotation arrow located on the fan housing.

**Note:** For motor warranty needs, contact your local Trane sales office.

## Unit Operation

### **⚠ WARNING**

#### **Rotating Components!**

Failure to disconnect power before servicing could result in rotating components cutting and slashing technician which could result in death or serious injury.

During installation, testing, servicing and troubleshooting of this product it may be necessary to work with live and exposed rotating components. Have a qualified or licensed service individual who has been properly trained in handling exposed rotating components, perform these tasks.

### **⚠ WARNING**

#### **Live Electrical Components!**

Failure to follow all electrical safety precautions when exposed to live electrical components could result in death or serious injury.

When it is necessary to work with live electrical components, have a qualified licensed electrician or other individual who has been properly trained in handling live electrical components perform these tasks.

Before complete start-up, bump-start the unit and confirm the fan wheel rotates properly, as indicated by the rotation arrow located on the fan housing.

After initial start-up:

- Calculate the motor voltage imbalance, notifying the power company to correct unacceptable imbalances.
- Periodically check the fan belt tension.

## Calculate Motor Voltage Imbalance

After start-up, measure the motor voltage and amperage on all phases to ensure proper operation. The readings

should fall within the range given on the motor nameplate. The maximum allowable voltage imbalance is 2 percent.

Voltage imbalance is defined as 100 times the sum of the deviation of the three voltages from the average, divided by twice the average voltage. For example, if the three measured voltages are 221, 230 and 227, the average voltage would be 226 volts. The percent of voltage imbalance is then calculated.

$$\text{Voltage imbalance} = \frac{100 A}{2 \times \text{Avg voltage}}$$

#### **Where:**

$$A = (226-221) + (230-226) + (227-226)$$

$$\text{Voltage imbalance} = 2.2\% \text{ (not acceptable)}$$

In the example, 2.2 percent imbalance is not acceptable and the power company should be notified to correct it.

## VFD Programming Parameters

Units shipped with an optional variable frequency drive (VFD) are preset and run-tested at the Trane factory. If a problem with a VFD occurs, ensure that the programmed parameters listed in [Table 14, p. 82](#) have been set. If trouble still persist after verifying factory parameters are correct, call Trane Drive Technical Support at 1-877-872-6363. Have the unit serial number from the drive available for the technical support representative. The technician will determine if drive can be repaired or needs to be replaced.

**Table 13. Trane TR150 switching frequency**

Horsepower	Voltage Max	KHz	Trane Setting
0.5 – 15	208/230	16	16
20 – 60	208/230	12	12
0.5 – 30	460	16	16
40 – 125	460	12	12
0.5 – 10	575	12	12
15 – 125	575	8	8

### **⚠ WARNING**

#### **Hazardous Voltage w/Capacitors!**

Failure to disconnect power and discharge capacitors before servicing could result in death or serious injury.

Disconnect all electric power, including remote disconnects and discharge all motor start/run capacitors before servicing. Follow proper lockout/tagout procedures to ensure the power cannot be inadvertently energized. For variable frequency drives or other energy storing components provided by Trane or others, refer to the appropriate manufacturer's literature for allowable waiting periods for discharge of capacitors. Verify with a CAT III or IV voltmeter rated per NFPA 70E that all capacitors have discharged.



## Start-Up

**Table 14. Trane TR150 VFD programming parameters**

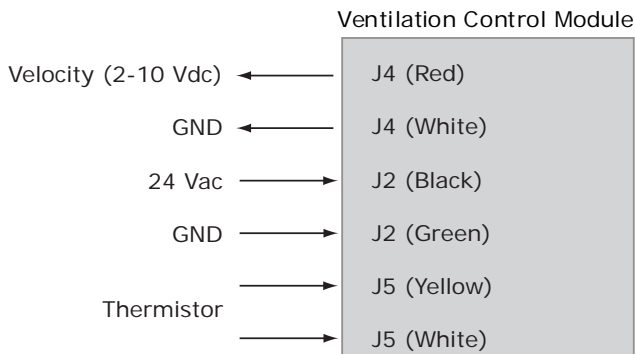
Parameter # TR150	Description	Factory Default	Trane Setting
0-03	Region	International	North American
1-03	Torque Characteristics	Auto Energy Optim. VT	Variable Torque [1] for Direct-Drive Fans
1-20	Motor Power	Depends on unit	Set Based on Motor Nameplate
1-22	Motor Voltage	Depends on unit	Set Based on Motor Nameplate
1-24	Motor Current	Depends on unit	Set Based on Motor Nameplate
1-25	Rated Motor	Speed Depends on unit	Set Based on Motor Nameplate
1-71	Start Delay	0.0 Sec	2 Sec
1-73	Flying Start	Disabled	Enable
1-90	Motor Thermal Protection	ETR Trip 1 [4]	ETR Trip 1 [4]
3-02	Minimum Reference	Application dependant	0 Hz
3-03	Maximum Reference	60Hz	60 or the Value of Maximum Inverter Frequency (Hz) on nameplate if fan is direct drive.
3-15	Terminal 53 Analog Input	Analog Input 53	Analog Input 53
3-41	Ramp-up Time	Application dependant	30 Sec
3-42	Ramp-down Time	Application dependant	30 Sec
4-12	Output Freq Low Limit	Application dependant	20 Hz
4-14	Output Freq High Limit	60 or the Value of Maximum Inverter Frequency (Hz) on nameplate if fan is direct drive.	60 or the Value of Maximum Inverter Frequency (Hz) on nameplate if fan is direct drive.
4-18	Current Limit	Application dependant	110%
4-19	Max Output Frequency	Application dependant	65 Hz or 120 Hz for Direct Drive Fan
5-12	Terminal 27 Digital	Input No Operation	Coast Inverse
5-40	Function Relay	No Operation	Relay 1 Active No Alarm [160] Relay 2 Active Motor Running [5]
6-14	Terminal 53 Low Ref Feedback	0.0 Hz	20 Hz
6-15	Terminal 53 High Ref Feedback	Application dependant	60 or the Value of Maximum Inverter Frequency (Hz) on Nameplate if fan is direct drive.
14-01	Switching Frequency	5.0 kHz	Set to Max for HP (see <a href="#">Table 13, p. 81</a> )
14-20	Reset Mode	Manual Reset	Automatic Reset x 5

## Airflow Measuring Systems

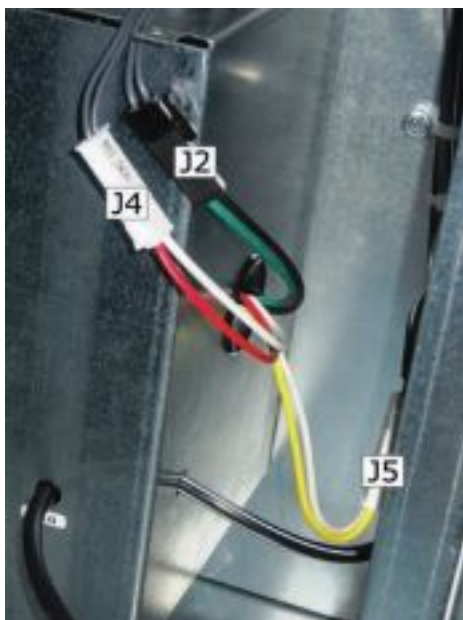
### Traq™ Dampers

Traq dampers are low-leak dampers that modulate and measure airflow. Each Traq damper section is supplied with a factory-mounted ventilation control module (VCM) on the interior of the mixing box section. The VCM has an input terminal for power and an output terminal for air velocity (see [Figure 100, p. 83](#)). A direct-digital controller controls the factory-mounted and wired actuators.

**Figure 100. Traq damper terminal connections**



**Figure 101. Traq damper terminal connections**



**VCM (Transducer) Calibration:** The VCM has an autozero function that recalibrates the transducer once every minute. When troubleshooting, allow for the recalibration time before making any measurements.

**Input Power:** The only input the VCM needs is the 24 Vac power connected to the J2 plug (green and black wires).

**Output Velocity Signal:** The 2 to 10 Vdc linear output signal from the VCM represents air velocity. This voltage can be converted to represent airflow (cfm or L/s) using the formula below and [Table 15, p. 83](#).

$$\text{Airflow} = k \text{ (cfm @ 10V)} \left[ \frac{(\text{volts } 2)}{8} \right]$$

or

$$\text{Airflow} = k \text{ (L/s @ 10V)} \left[ \frac{(\text{volts } 2)}{8} \right]$$

For example, if the VCM on a size 30 air handler at sea level ( $k = 1$ ) has a 10-volt signal, it would represent 24,492 cfm (11,559 L/s) through the Traq damper. If the voltage

were 6 volts, airflow through the Traq damper would be 12,246 cfm (5779 L/s).

**Table 15. Altitude adjustment factors**

Sea level = 1.0	
Elevation (feet)	k
1000	0.982
2000	0.964
3000	0.949
4000	0.930
5000	0.914
6000	0.897
7000	0.876
8000	0.860
9000	0.846
10,000	0.825

**Table 16. Traq damper flow calculations**

Traq Damper Size (In.)	Qty	Peak Velocity (fpm)	Total Area (ft <sup>2</sup> )	CFM @ 10Vdc Peak Vel	L/S @ 10Vdc Peak Vel
13	1	2475	0.92	2277	1075
13	2	2475	1.84	4554	2149
13	3	2475	2.77	6855.75	3236
13	4	2475	3.69	9132.75	4311
13	5	2475	4.61	11409.75	5385
13	6	2475	5.53	13686.75	6460
16	1	2475	1.4	3465	1635
16	2	2475	2.79	6905.25	3259
16	3	2475	4.19	10370.25	4895
16	4	2475	5.59	13835.25	6530
16	5	2475	6.98	17275.5	8154
16	6	2475	8.38	20740.5	9790
20	1	2600	2.18	5668	2675
20	2	2600	4.36	11336	5351
20	3	2600	6.54	17004	8026
20	4	2600	8.73	22698	10713
20	5	2600	10.91	28366	13389
20	6	2600	13.09	34034	16064
24	1	2600	3.14	8164	3853
24	2	2600	6.28	16328	7707
24	3	2600	9.42	24492	11560
24	4	2600	12.57	32682	15426

**Table 16. Traq damper flow calculations (continued)**

Traq Damper Size (In.)	Qty	Peak Velocity (fpm)	Total Area (ft <sup>2</sup> )	CFM @ 10Vdc Peak Vel	L/S @ 10Vdc Peak Vel
24	5	2600	15.71	40846	19279
24	6	2600	18.85	49010	23133
28	1	2600	4.28	11128	5252
28	2	2600	8.55	22230	10493
28	3	2600	12.83	33358	15745
28	4	2600	17.1	44460	20985
28	5	2600	21.38	55588	26238
28	6	2600	25.66	66716	31490

**Note:** For low flow see single damper performance.

In Table 16, p. 83, the cfm at 10Vdc is a calculated value based on area and peak velocity. In certain situations, it can be advantageous to raise the velocity of air through the remaining Traq dampers by closing off one or more dampers in the unit. The cfm at 10Vdc can be recalculated based on the proportion of remaining Traq dampers or by multiplying the remaining area of dampers by peak velocity. Calculations are based on VCM voltage versus airflow at sea level.

Trane utilizes AMCA certification for airflow measuring stations. Trane certifies that the Traq damper herein is licensed to bear the AMCA seal. The ratings shown are based on tests and procedures performed in accordance with AMCA Publication 611 and comply with the requirements of the AMCA Certified Ratings Program.

The certification program provides the engineer and owner assurance that manufacturer-published performance ratings for airflow measurement stations are accurate and repeatable. Trane Traq dampers are certified with the integral ventilation control module which converts differential pressure to an electronic signal for control.

See *Performance Climate Changer Air Handler Product Catalog (CLCH-PRC015\*-EN)* for Traq damper testing and rating information.

## Fan Inlet Airflow Measuring System

A fan inlet airflow measuring system (piezometer) is available on many centrifugal and plenum fans. Trane system determines airflow using a static pressure differential.

**Note:** This type of system is different than a total pressure or thermal dispersion system. As such, the calculations will be different.

Each system comes with a differential pressure transmitter. The minimum diameter is connected to the LO port of the transmitter and the reference pressure point is connected to (or actually is) the HI port of the transmitter.

**Figure 102. Fan inlet airflow measuring system**


## Wiring

The transmitter requires 24 Vdc/24 Vac power on terminals 1 (+) and 2 (ground) of the transmitter. When the airflow measurement system is ordered with a factory-mounted Symbio™ controller, the 24 Vdc power will be supplied.

In the absence of a factory-mounted Symbio controller, the installing contractor must ensure the transmitter has 24 Vdc/24 Vac power.

## Transmitter Sizing

The Trane specification requires that the flow meter option have a total accuracy of 5 percent. The total accuracy is a combination of:

- how accurately the flow meter itself is in sensing airflow
- how accurately the transmitter senses the differential pressure
- how accurately the controller translates the signal from the transmitter to a differential pressure.

Selecting the proper transmitter is critical in order to get accurate airflow measurements. How accurately the transmitter senses the differential pressure is dependent on:

- the pressure range selected
- the accuracy of the selected transmitter

Trane air handlers use a 0 to 5-inch, 0 to 10-inch, or 0 to 25-inch w.g. range transmitter as standard. To sufficiently cover VAV turndown on the smallest fans with the above range, a transmitter with an accuracy of 0.25 percent (full scale) is used as standard. If a field-provided transmitter with a lower accuracy is selected, the range should be chosen closer to the actual, maximum pressure differential expected for the application.

The transmitter outputs a signal that represents the differential pressure which is used to calculate airflow. To adequately calculate and display the airflow for the smaller fans, ensure that the analog input is programmed with enough decimal places to sufficiently represent the pressure differential being measured.

**Note:** *The transmitter is factory-calibrated to the range selected and cannot be significantly adjusted to tighten the range closer to the pressure being read for the given application.*

### Transmitter Calibration

The transmitter is factory-calibrated to a specific pressure range with a 0 to 5-inch, 0 to 10-inch, or 0 to 25-inch w.g. range being used in most cases. To check calibration and to adjust if necessary, consult the transmitter manufacturer or the factory for specific procedures.

The transmitter outputs a linear, 2-10 Vdc signal representing a differential pressure measurement. With this measurement, the airflow through the fan can be calculated using the following equation:

$$CFM = K * \text{SQRT}(DP)$$

Where: CFM = Airflow (ft<sup>3</sup>/min.) assuming a standard air density of 0.075 lbm/ft<sup>3</sup>.

K = A constant factor that is unique for each fan. See "Constant Factor K," p. 85 for more information.

DP = Differential pressure (inches w.g.) being measured by the transmitter.

Significant differences in elevation and/or temperature will affect the density of air. For air at a constant, non-standard

density, a field-obtained K factor can be used. Alternatively, the following equation can be used to continuously correct the equation above:

$$ACFM = CFM * \text{SQRT}(0.075/\rho)$$

Where: ACFM = Actual airflow (ft<sup>3</sup>/min.) corrected for non-standard air density.

ρ = Density (lbm/ft<sup>3</sup>) of the air at the inlet to the fan.

**Note:** *Alternative units, including SI, can be used in place of the IP units above although the K-factor must be converted appropriately.*

### Maintenance

For a typical HVAC environment - especially with upstream filtration - there should be little to no required maintenance. In extreme cases or for mishaps (bearing grease in the taps for example), the flow meter is easily cleanable. The fan inlet airflow measuring system is extremely simple: a few pressure taps, a few fittings, and some tubing. Although unlikely, if any tap were to get clogged, simply disconnect each side of the transmitter and blast air in a reverse direction through the system.

### Constant Factor K

The constant factor K is unique for each fan and is primarily a function of the area and other geometric properties of the fan inlet. Pre-engineered factors are available from the factory for fan types where the airflow measurement system is available.

**Table 17. Constant K factors — generation 1 DDP fans and MI fans**

Fan Size (inches)/Type	Fan Class	Fan Name	K-Factor
10.50 AF direct-drive plenum	Any	10 TF, 10 TR, 10 UF, 10 UR	576
12 AF direct-drive plenum	Any	12 TF, 12 TR, 12 UF, 12 UR	945
13.50 AF direct-drive plenum	Any	13 TF, 13 TR, 13 UF, 13 UR	965
15 AF direct-drive plenum	Any	15 TF, 15 TR, 15 UF, 15 UR	1227
16 AF direct-drive plenum	Any	16 TF, 16 TR, 16 UF, 16 UR	1519
18 AF direct-drive plenum	Any	18 TF, 18 TR, 18 UF, 18 UR	1822
20 AF direct-drive plenum	Any	20 TF, 20 TR, 20 UF, 20 UR	2186
22 AF direct-drive plenum	Any	22 TF, 22 TR, 22 UF, 22 UR	2649
24 AF direct-drive plenum	Any	24 TF, 24 TR, 24 UF, 24 UR	3092
27 AF direct-drive plenum	Any	27 TF, 27 TR, 27 UF, 27 UR	4156
30 AF direct-drive plenum	Any	30 TF, 30 TR, 30 UF, 30 UR	4945
12.20 motorized impeller	Any	12 VP, 12 EP, 12 FM	1078
15.70 motorized impeller	Any	15 VP, 15 EP, 15 FM	1747
17.70 motorized impeller	Any	17 VP, 17 EP, 17 FM	2231



## Start-Up

**Table 17. Constant K factors — generation 1 DDP fans and MI fans (continued)**

Fan Size (inches)/Type	Fan Class	Fan Name	K-Factor
19.70 motorized impeller	Any	19 VP, 19 EP, 19 FM	2612
22.00 motorized impeller	Any	22 VP, 22 EP, 22 FM	3233

**Table 18. Constant K factors — generation 2 DDP fans and MI fans**

Fan Size (inches)/Type	Fan Class	Fan Name	K-Factor
10.50 AF direct-drive plenum	Any	10 UF	598
12 AF direct-drive plenum	Any	12 UF	763
13.50 AF direct-drive plenum	Any	13 UF	910
15 AF direct-drive plenum	Any	15 UF	1181
16 AF direct-drive plenum	Any	16 UF	1441
18 AF direct-drive plenum	Any	18 UF	1688
20 AF direct-drive plenum	Any	20 UF	2136
22 AF direct-drive plenum	Any	22 UF	2649
24 AF direct-drive plenum	Any	24 UF	3092
27 AF direct-drive plenum	Any	27 UF	4156
30 AF direct-drive plenum	Any	30 UF	4810
12.20 motorized impeller	Any	12VP, 12EP, 12FM	1078
13.90 motorized impeller	Any	13VP, 13FM	1375
13.90 motorized impeller	Any	13FM	1141
15.70 motorized impeller	Any	15VP, 15EP, 15RM	1747
17.70 motorized impeller	Any	17VP, 17EP, 17FP, 17FM	2231
19.70 motorized impeller	Any	19 VP, 19EP, 19FP, 19FM	2612
19.70 motorized impeller	Any	19FM	2045
22.00 motorized impeller	Any	22 VP, 22EP, 22FP, 22FM, 22RM	3233

When a single transmitter is supplied in a multiple fan system, one or more fans will be brought back to the transmitter as a manifold and the airflow will represent the total airflow for the system. As a result, the factor should be adjusted as follows:

$$K = N * K\text{-Factor}$$

Where:

K = The final factor to be used for controller programming.

N = The number of active\* fans in the system.

\*If a fan fails in a multiple fan system where only one transmitter is being supplied, and if the remaining fans will continue to be used, the factor should be reduced accordingly. Additionally, if the inactive fan was included in the manifold back to the transmitter, the tubes from the inactive fan should be temporarily removed and replaced with tubes from an active fan (or simply plugged).

When a transmitter is supplied for each fan, the factor does not need to be adjusted. The resulting airflow will represent single-fan airflow. At the controller level, the individual airflows should be summed to get the total airflow. If a field-provided K-factor is to be used (see below), the measured airflow for the system should be divided by the number of active fans to get a single-fan K-factor.

Field-obtained factors can provide maximum accuracy. To obtain the factor in the field, measure the differential pressure output from the transmitter while measuring the airflow through the system. Once these two values have been measured, simply solve for K using the following equation:

$$K = \text{ACFM} / \text{SQRT}(\text{DP})$$

Where:

K = Field-provided constant factor.

ACFM = Actual airflow (ft<sup>3</sup>/min.) being measured at the air density being measured.

DP = Differential pressure (inches w.g.) being measured by the transmitter.

## **External Insulating Requirements**

The following areas should be specifically addressed, as applicable:

- Supply and return water piping connections
- Supply and return refrigerant piping connections
- Condensate drain lines and connections
- Outdoor-air-intake duct connections
- Discharge duct connections
- Special requirements for low-temperature-air systems

# Routine Maintenance

## ⚠ WARNING

### Hazardous Service Procedures!

Failure to follow all precautions in this manual and on the tags, stickers, and labels could result in death or serious injury.

Technicians, in order to protect themselves from potential electrical, mechanical, and chemical hazards, **MUST** follow precautions in this manual and on the tags, stickers, and labels, as well as the following instructions: Unless specified otherwise, disconnect all electrical power including remote disconnect and discharge all energy storing devices such as capacitors before servicing. Follow proper lockout/tagout procedures to ensure the power can not be inadvertently energized. When necessary to work with live electrical components, have a qualified licensed electrician or other individual who has been trained in handling live electrical components perform these tasks.

## ⚠ WARNING

### Rotating Components!

Failure to disconnect power before servicing could result in rotating components cutting and slashing technician which could result in death or serious injury.

During installation, testing, servicing and troubleshooting of this product it may be necessary to work with live and exposed rotating components. Have a qualified or licensed service individual who has been properly trained in handling exposed rotating components, perform these tasks.

## Maintenance Checklist

Table 19. Maintenance checklist

Frequency	Maintenance
Every week	<input type="checkbox"/> Observe unit weekly for any change in running condition and unusual noise.
Every month	<input type="checkbox"/> Clean or replace air filters if clogged or dirty; coat permanent filters with oil after cleaning; change bag filters when pressure drop is 1 in. w.g. See "Filters," p. 93 for more information.
Every three to six months	<input type="checkbox"/> Inspect and clean drain pans. See "Drain Pans," p. 91 for more information. <input type="checkbox"/> Tighten electrical connections. <input type="checkbox"/> Inspect coils for dirt build-up. See "Coils," p. 89 for more information. <input type="checkbox"/> Clean moisture eliminator with high pressure sprayer. Remove pollen in the spring and leaves in the fall.
Every year	<input type="checkbox"/> Inspect the unit casing for corrosion. If damage is found, clean and repaint. <input type="checkbox"/> Clean the fan wheels and shaft. See "Fans," p. 92 for more information. <input type="checkbox"/> Inspect and clean drain pans. <input type="checkbox"/> Check damper linkages, set screws, and blade adjustment. Clean, but do not lubricate, the nylon damper rod bushings. <input type="checkbox"/> Clean damper operators. <input type="checkbox"/> Inspect electrical components and insulation. <input type="checkbox"/> Inspect wiring for damage. <input type="checkbox"/> Rotate the fan wheel and check for obstructions. The wheel should not rub. Adjust the center if necessary. <input type="checkbox"/> Lubricate motor bearings in accordance with motor manufacturer's recommendations (see "Motor Bearing Lubrication," p. 92 for more information). <input type="checkbox"/> Check condition of gasketing and insulation around unit, door and dampers. <input type="checkbox"/> Examine flex connections for cracks or leaks. Repair or replace damaged material.

## Cleaning the Unit

### Cleaning Non-Porous Surfaces

#### **⚠ WARNING**

##### **Hazardous Voltage!**

Failure to disconnect power before servicing could result in death or serious injury.

Disconnect all electric power, including remote disconnects before servicing. Follow proper lockout/tagout procedures to ensure the power can not be inadvertently energized. Verify that no power is present with a voltmeter.

If microbial growth on a non-porous insulating surface (closed cell insulation or sheet metal surface) is observed:

1. Disconnect all electrical power to the unit.
2. Wearing the appropriate personal protective equipment, use a brush for sheet metal surfaces or a soft sponge on a foil face or closed cell foam surface to mechanically remove the microbial growth.

*Note: Be careful not to damage the non-porous surface of the insulation.*

3. Install a block-off to prevent spray from going into a dry section of the unit and/or system ductwork.
4. Thoroughly clean the contaminated area(s) with an EPA-approved sanitizer specifically designed for HVAC use.
5. Rinse the affected surfaces thoroughly with fresh water and a fresh sponge to prevent potential corrosion of the drain pan and drain line.
6. Repeat steps 4 and 5 as necessary.
7. Confirm the drain line is open following the cleaning process.
8. Allow the unit to dry thoroughly before putting it back into service.
9. Replace all panels and parts and restore electrical power to the unit.
10. Be careful any contaminated material does not contact other areas of the unit or building. Properly dispose of all contaminated materials and cleaning solution.

### Cleaning Porous Surfaces

#### **⚠ WARNING**

##### **Hazardous Voltage!**

Failure to disconnect power before servicing could result in death or serious injury.

Disconnect all electric power, including remote disconnects before servicing. Follow proper lockout/tagout procedures to ensure the power can not be inadvertently energized. Verify that no power is present with a voltmeter.

To clean a porous insulating surface (fiberglass insulation):

1. Disconnect all electrical power to the unit.
2. Wearing the appropriate personal protective equipment, use a vacuum device with a HEPA filter (99.97 percent efficient at 0.3 micron particles) to remove the accumulated dirt and organic matter.  
*Note: Be careful not to tear the insulation surface or edges*
3. Confirm the drain line is open following the cleaning process.
4. Allow the unit to dry thoroughly before putting it back into service.
5. Replace all panels and parts and restore electrical power to the unit.
6. Be careful any contaminated material does not contact other areas of the unit or building. Properly dispose of all contaminated materials and cleaning solution.

## Coils

All coils should be kept clean to maintain maximum performance.

### Steam and Water Coils

#### **⚠ WARNING**

##### **Hazardous Voltage!**

Failure to disconnect power before servicing could result in death or serious injury.

Disconnect all electric power, including remote disconnects before servicing. Follow proper lockout/tagout procedures to ensure the power can not be inadvertently energized. Verify that no power is present with a voltmeter.

#### **⚠ WARNING**

##### **Hazardous Chemicals!**

Failure to follow this safety precaution could result in death or serious injury. Coil cleaning agents can be either acidic or highly alkaline and can burn severely if contact with skin or eyes occurs.

Handle chemical carefully and avoid contact with skin. **ALWAYS** wear Personal Protective Equipment (PPE) including goggles or face shield, chemical resistant gloves, boots, apron or suit as required. For personal safety refer to the cleaning agent manufacturer's Materials Safety Data Sheet and follow all recommended safe handling practices.

To clean steam and water coils:

1. Disconnect all electrical power to the unit.
2. Wearing the appropriate personal protective equipment, use a soft brush to remove loose debris from both sides of the coil.



## Routine Maintenance

3. Install a block-off to prevent spray from going through the coil and into a dry section of the unit and/or system ductwork.

4. Mix a high-quality coil cleaning detergent with water according to the manufacturer's instructions.

**Note:** *If the detergent is strongly alkaline after mixing (PH 8.5 or higher), it must contain an inhibitor. Follow the cleaning solution manufacturer's instructions regarding the use of the product.*

5. Place the mixed solution in a garden pump-up sprayer or high-pressure sprayer. If a high pressure sprayer is to be used:

- Maintain minimum nozzle spray angle of 15 degrees.
- Spray perpendicular to the coil face.
- Keep the nozzle at least 6 inches from the coil.
- Do not exceed 600 psi.

6. Spray the leaving air side of the coil first, then the entering air side.

7. Thoroughly rinse both sides of the coil and the drain pan with cool, clean water.

8. Repeat step 6 and step 7 as necessary.

9. Straighten any coil fins that may have been damaged during the cleaning process.

10. Confirm the drain line is open following the cleaning process.

11. Allow the unit to dry thoroughly before putting it back into service.

12. Replace all panels and parts and restore electrical power to the unit.

13. Be careful any contaminated material does not contact other areas of the unit or building. Properly dispose of all contaminated materials.

## Refrigerant Coils

### ⚠ WARNING

#### Hazardous Pressures!

Failure to follow instructions could result in coil bursting, which could result in death or serious injury. Coils contain refrigerant under pressure. To avoid excessive pressure in the coil, do not exceed 150°F coil cleaning solution temperature.

### ⚠ WARNING

#### Hazardous Voltage!

Failure to disconnect power before servicing could result in death or serious injury. Disconnect all electric power, including remote disconnects before servicing. Follow proper lockout/tagout procedures to ensure the power can not be inadvertently energized. Verify that no power is present with a voltmeter.

### ⚠ WARNING

#### Hazardous Chemicals!

Failure to follow this safety precaution could result in death or serious injury. Coil cleaning agents can be either acidic or highly alkaline and can burn severely if contact with skin or eyes occurs.

Handle chemical carefully and avoid contact with skin. **ALWAYS** wear Personal Protective Equipment (PPE) including goggles or face shield, chemical resistant gloves, boots, apron or suit as required. For personal safety refer to the cleaning agent manufacturer's Materials Safety Data Sheet and follow all recommended safe handling practices.

To clean refrigerant coils:

- Disconnect all electrical power to the unit.
- Wearing the appropriate personal protective equipment, use a soft brush to remove loose debris from both sides of the coil.
- Install a block-off to prevent spray from going through the coil and into a dry section of the unit and/or system ductwork.
- Mix a high-quality coil cleaning detergent with water according to the manufacturer's instructions.

**Note:** *If the detergent is strongly alkaline after mixing (PH 8.5 or higher), it must contain an inhibitor. Follow the cleaning solution manufacturer's instructions regarding the use of the product.*

- Place the mixed solution in a garden pump-up sprayer or high-pressure sprayer. If a high pressure sprayer is to be used:
  - Maintain minimum nozzle spray angle of 15 degrees.
  - Spray perpendicular to the coil face.
  - Keep the nozzle at least 6-inches from the coil.
  - Do not exceed 600 psi.
- Spray the leaving air side of the coil first, then the entering air side.
- Thoroughly rinse both sides of the coil and the drain pan with cool, clean water.
- Repeat step 6 and step 7 as necessary.
- Straighten any coil fins damaged during the cleaning process.
- Confirm the drain line is open following the cleaning process.
- Allow the unit to dry thoroughly before putting it back into service.
- Replace all panels and parts and restore electrical power to the unit.
- Be careful any contaminated material does not contact other areas of the unit or building. Properly dispose of all contaminated materials and cleaning solution.

## Coil Winterization

Water coil winterization procedures consist primarily of draining water from the coil before the heating season. Trane recommends flushing the coil with glycol if coils will be exposed to temperatures below 35 degrees.

### NOTICE

#### Coil Freeze-Up!

Failure to follow instruction below could result in equipment damage.

**Drain and vent coils when not in use. Trane recommends glycol protection in all possible freezing applications. Use a glycol approved for use with commercial cooling and heating systems and copper tube coils.**

Install field-fitted drains and vents to permit winterization of coils not in use and to assist in evacuating air from the water system during start-up. If draining is questionable because of dirt or scale deposits inside the coil, fill the coil with glycol before the heating season begins.

Individual coil types determine how to properly winterize the coil. To determine the coil type find the **Service Model No of Coil** on the coil section nameplate. The coil type is designated by the second and third digits on that model number. For example, if the model number begins with **DUWB**, the coil type is UW; if the model number begins with **DW0B**, the coil type is W.

**Note:** *On many unit sizes, there are multiple coils in the coil section. Be sure to winterize all coils in a given coil section.*

To winterize type D1, D2, WL, LL, UA, UW, UU, W, P2, P4, P8, WD, 5D, and 5W coils:

1. Remove the vent and drain plugs.
2. Blow the coil out as completely as possible with compressed air.
3. Fill and drain the coil several times with full strength glycol so that it mixes thoroughly with the water retained in the coil.
4. Drain the coil out as completely as possible.
5. To ensure no water remains in the coil, do not replace the vent and drain plugs until the coils are put back into service.

**Note:** *Use care in removing header plugs from Type P2, P4, and P8 coils. Over-torquing may result in twisted tubes.*

## Moisture Purge Cycle

By its very nature, any HVAC unit with a cooling coil serves as a dehumidifier, reducing the surrounding air's ability to hold water vapor as its temperature falls. This normally doesn't present a problem when the unit is running. However, when the fan stops, water vapor condenses on the cold metal surfaces inside the air handler and remains there until the air warms sufficiently to re-evaporate it. This

damp, dark environment — though temporary— can encourage the growth of mold, mildew, and other microbial contaminants.

Providing a moisture purge cycle 15 to 30 minutes after shutdown disperses the cold, humid air inside the air-handling.

## Drain Pans

### ⚠ WARNING

#### Hazardous Voltage!

Failure to disconnect power before servicing could result in death or serious injury.

**Disconnect all electric power, including remote disconnects before servicing. Follow proper lockout/tagout procedures to ensure the power can not be inadvertently energized. Verify that no power is present with a voltmeter.**

### ⚠ WARNING

#### No Step Surface!

Failure to follow instruction below could result in death or serious injury.

**Do not walk on the sheet metal drain pan. Walking on the drain pan could cause the supporting metal to collapse and result in the operator/technician falling.**

The condensate drain pan and drain line must be checked to assure the condensate drains as designed. This inspection should occur a minimum of every six months or more often as dictated by operating experience.

If evidence of standing water or condensate overflow exists, identify and remedy the cause immediately. See "Troubleshooting," p. 95 for possible causes and solutions.

To clean drain pans:

1. Disconnect all electrical power to the unit.
2. Wearing the appropriate personal protective equipment, remove any standing water.
3. Scrape solid matter off of the drain pan.
4. Vacuum the drain pan with a vacuum device that uses high efficiency particulate arrestance (HEPA) filters with a minimum efficiency of 99.97 percent at 0.3 micron particle size.
5. Thoroughly clean any contaminated area(s) with a mild bleach and water solution or an EPA-approved sanitizer specifically designed for HVAC use.
6. Immediately rinse the affected surfaces thoroughly with fresh water and a fresh sponge to prevent potential corrosion of metal surfaces.
7. Allow the unit to dry completely before putting it back into service.
8. Be careful any contaminated material does not contact other areas of the unit or building. Properly dispose of all contaminated materials and cleaning solution.

## Fans

### **⚠ WARNING**

#### **Rotating Components!**

**Failure to secure rotor or disconnect power before servicing could result in rotating components cutting and slashing technician which could result in death or serious injury.**

**The following procedure involves working with rotating components.**

- **Disconnect all electric power, including remote disconnects before servicing.**
- **Follow proper lockout/tagout procedures to ensure the power cannot be inadvertently energized.**
- **Secure rotor to ensure rotor cannot freewheel.**

## Inspecting and Cleaning Fans

Fan sections of air handlers should be inspected every six months at a minimum or more frequently if operating experience dictates. If evidence of microbial growth (mold) is found, identify and remedy the cause immediately. Refer to “[Troubleshooting](#),” p. 95 for possible causes and solutions. To clean the fan section:

1. Disconnect all electrical power to the unit.
2. Wearing the appropriate personal protective equipment, remove any contamination.
3. Vacuum the section with a vacuum device that uses high efficiency particulate arrestance (HEPA) filters with a minimum efficiency of 99.97 percent at 0.3 micron particle size.
4. Thoroughly clean any contaminated area(s) with a mild bleach and water solution or an EPA-approved sanitizer specifically designed for HVAC use.
5. Immediately rinse the affected surfaces thoroughly with fresh water and a fresh sponge to prevent potential corrosion of metal surfaces.
6. Allow the unit to dry completely before putting it back into service.
7. Be careful any contaminated material does not contact other areas of the unit or building. Properly dispose of all contaminated materials and cleaning solution.

## Motor Bearing Lubrication

Obtain an operation and maintenance manual from the motor manufacturer for the specific motor installed. The motor manufacturer’s recommendations take precedence for all matters related to the start-up and routine maintenance of the motor.

Motor grease fittings have been removed from factory-installed motors in compliance with UL regulations. Motor bearings require periodic maintenance throughout their life. Many different styles of motors come as standard

selections, so please obtain the motor IOM and use the manufacturer-recommended grease.

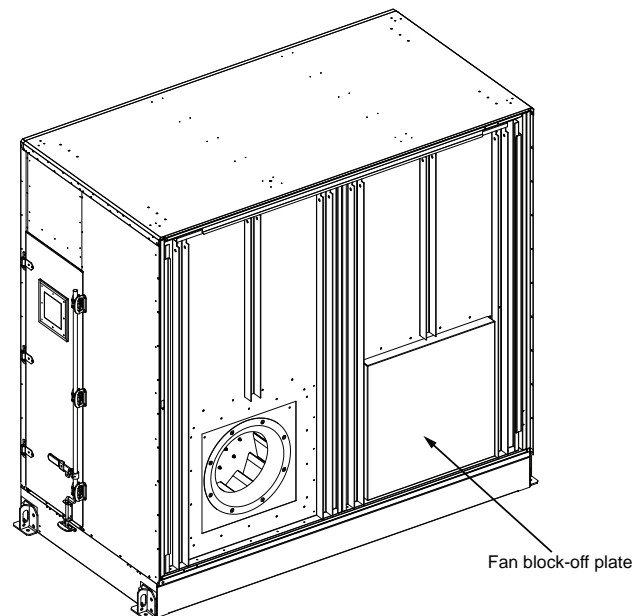
## Fan Motor Inspection

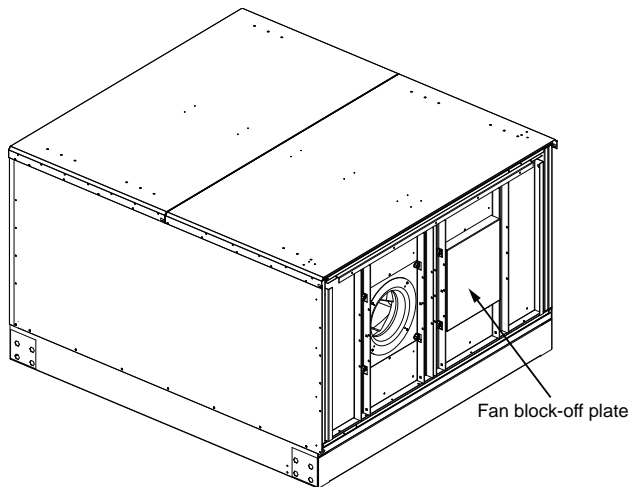
Inspect fan motors periodically for excessive vibration or temperature. Operating conditions will vary the frequency of inspection and lubrication. Motor lubrication instructions are on the motor tag or nameplate. If for some reason these instructions are not available, contact the motor manufacturer. Some motor manufacturers may not provide oil tubes on motors with permanently sealed bearings.

## Fan Block-off Plate

Mount one plate on a fan that is out of operation. For direct-drive plenum fans, the plate will be mounted directly to the fan wall. For motorized impeller fans, the plate will be mounted to the support stiffeners attached to the fan wall.

**Figure 103. DDP fan block-off plate**



**Figure 104. MI fan block-off plate**


## Filters

### **⚠ WARNING**

#### **Rotating Components!**

Failure to secure rotor or disconnect power before servicing could result in rotating components cutting and slashing technician which could result in death or serious injury.

The following procedure involves working with rotating components.

- **Disconnect all electric power, including remote disconnects before servicing.**
- **Follow proper lockout/tagout procedures to ensure the power cannot be inadvertently energized.**
- **Secure rotor to ensure rotor cannot freewheel.**

## Throwaway Filters

To replace throwaway filters, install new filters with the directional arrows pointing in the direction of airflow.

**Note:** Bag and cartridge filters must have an airtight seal to prevent air bypass. If using filters not supplied by Trane, apply foam gasketing to the vertical edges of the filter.

## Permanent Filters

To clean permanent filters:

1. Disconnect all electrical power to the unit.
2. Wash the filter under a stream of water to remove dirt and lint.
3. Remove oil from the filter with a wash of mild alkali solution.
4. Rinse the filter in clean, hot water and allow to dry.

5. Coat both sides of the filter by immersing or spraying it with Air Maze Filter Kote W or an equivalent.
6. Allow to drain and dry for about 12 hours.
7. Reinstall the filter.

**Note:** It may be preferable to keep extra, clean filters to replace the dirty filters to minimize unit downtime for filter maintenance.

## Cartridge or Bag Filters

To replace cartridge or bag filters:

1. Disconnect all electrical power to the unit.
  2. Remove the dirty filters from their installed position.
  3. Keeping the new bag filters folded, slide each filter into the filter rack, pushing them tightly against the unit.
- Note:** The pleats should be in the vertical position.
4. If using the optional pre-filters, replace them on the appropriate filter rack.
  5. Close and secure the access door.

## Moisture Eliminator

The moisture eliminators in the outside air intake hood must be cleaned periodically. Remove the eliminators by detaching the access panels to either side of the hood. Thoroughly clean the eliminator by using a high pressure sprayer. The airflow direction is imprinted on the frame of the eliminator. Direct the spray into the air leaving side of the eliminator for effective cleaning. Reassemble the eliminator into the hood, ensuring the eliminators are oriented in the proper airflow direction and access covers are securely attached.

## Ultraviolet (UV) Light Maintenance

The intensity of the ultraviolet energy emitted from the ultraviolet bulbs is dependent on the cleanliness and age of the bulb. The surface of the bulb should be kept as clean as possible for optimum intensity. Depending on the filtration level of the HVAC system and the general hygiene of the building, periodic cleaning may be necessary. Before attempting any maintenance procedures, always follow all warnings and cautions as detailed in this maintenance section.

**⚠ WARNING****Hazardous Voltage and Exposure to Ultraviolet Radiation!**

This product contains components that emit high-intensity ultraviolet (UV-C) radiation which can be harmful to unprotected eyes and skin, and cause serious damage to the equipment.

Failure to disconnect power before servicing could result in burns or electrocution which could result in death or serious injury.

Disconnect all electrical power, including remote disconnects, and make sure the UV lights are off before servicing. Follow proper lockout/tagout procedures to ensure the power cannot be inadvertently energized.

Trane does not recommend field installation of ultraviolet lights in its equipment for the intended purpose of improving indoor air quality. Trane accepts no responsibility for the performance or operation of our equipment in which ultraviolet devices were installed outside of the Trane factory or its approved suppliers.

**⚠ WARNING****Hazardous Mercury Vapors!**

Failure to follow instructions could result in death or serious injury. Mercury vapors are toxic and inhaling them could result in poisoning and suffocation.

If large numbers of UV bulbs are broken, an appropriate respirator, as described in OSHA 1910.134, MUST be worn to prevent inhalation of mercury vapors.

**Cleaning the Bulbs**

*Note: If bulbs are found to be broken, see the proper warning and cautions below regarding broken bulbs and hazardous vapors.*

1. Disconnect all electrical power to the unit and the ultraviolet bulbs.
2. Wearing soft cloth gloves and safety glasses, loosen the compression nut on each end of the bulb, use two hands and firmly grasp the bulb at each end.
3. Rotate the bulb 90 degrees in either direction and move bulb away from the fixture and out of unit.
4. Wipe down each bulb with a clean cloth and alcohol. Avoid touching the bulb with bare hands as skin oils can accelerate future glass soiling and degrade the bulb performance.
5. Wearing soft cloth gloves and safety glasses, install lamp by grasping each non-glass end with the thumb and index fingers. Carefully push lamp ends into previously mounted lamp clamps.
6. Attach the loom to the lamp by firmly pushing the four-port connector onto the four pins on the lamp end.

*Note: Connection must be snug to avoid potential arcing.*

**Replacing the Bulbs**

Ultraviolet bulbs should be replaced annually if operated continuously or after 9,000 hours of use if operated intermittently. Replacement bulbs must be the specific size and wattage as originally supplied from the factory.

*Note: Although the lights may continue to generate a characteristic blue glow beyond 9,000 operating hours, the ultraviolet radiation emitted by the bulbs degrades over time and will no longer provide the intended benefit.*

1. Disconnect power to the HVAC unit and the ultraviolet bulbs. See WARNING Hazardous Mercury Vapors.
2. Before installation, lamps should be cleaned using 99 percent isopropyl alcohol and a lint free cloth.

*Note: If Teflon coated EncapsuLamp™ is used, it is not necessary to clean the surface.*

3. Wearing soft cloth gloves and safety glasses, install lamp by grasping each non-glass end with the thumb and index fingers. Carefully push lamp ends into previously mounted lamp clamps.
4. Attach the loom to the lamp by firmly pushing the four-port connector onto the four pins on the lamp end.

*Note: Connection must be snug to avoid potential arcing.*

5. If broken bulbs are found or if you are required to dispose of used bulbs, the proper warning and cautions must be followed.

**⚠ CAUTION****Broken Glass!**

Failure to handle bulbs properly could result in minor to moderate injury.

**Bulbs are fragile and can be easily broken. To avoid getting cut, always use cloth gloves and eye protection when handling, cleaning or replacing these bulbs. Bulbs may break if dropped or handled improperly. Refer to the MSDS sheet from the bulb manufacturer for additional safety information.**

**Disposal of Bulbs**

UV bulbs, like fluorescent bulbs, contain mercury, which is a regulated hazardous waste. The disposal requirements for hazardous wastes are determined by local, state and federal guidelines. Check all regulations before disposing of bulbs to assure you have met all requirements.

Refer to the MSDS sheet from the bulb manufacturer for additional disposal, handling and safety information.

After replacing bulbs, close and latch all unit panels and reenergize power to the lights.



# Troubleshooting

This section is intended to be used as a diagnostic aid only. For detailed repair procedures, contact your local Trane service representative.

⚠ WARNING
<p><b>Hazardous Service Procedures!</b></p> <p>Failure to follow all precautions in this manual and on the tags, stickers, and labels could result in death or serious injury.</p> <p>Technicians, in order to protect themselves from potential electrical, mechanical, and chemical hazards, <b>MUST</b> follow precautions in this manual and on the tags, stickers, and labels, as well as the following instructions: Unless specified otherwise, disconnect all electrical power including remote disconnect and discharge all energy storing devices such as capacitors before servicing. Follow proper lockout/tagout procedures to ensure the power can not be inadvertently energized. When necessary to work with live electrical components, have a qualified licensed electrician or other individual who has been trained in handling live electrical components perform these tasks.</p>

**Table 20. Air handler troubleshooting recommendations**

Symptom	Probable Cause	Recommended Action
Motor fails to start	Blown fuse or open circuit breaker	Replace fuse or reset circuit breaker.
	Overload trip	Check and reset overload.
	Improper wiring or connections	Check wiring with diagram supplied on unit.
	Improper current supply	Compare actual supply power with motor nameplate recommendations. Contact power company for adjustments.
	Mechanical failure	Check that motor and drive rotate freely. Check bearing lubricant.
Motor stalls	Open phase	Check line for an open phase.
	Overloaded motor	Reduce load or replace with larger motor.
	Low line voltage	Check across AC line. Correct voltage if possible.
Excessive vibration	Shipping spacers not removed	Remove shipping spacers and/or bolts (see "Fan Isolation," p. 52).
Motor runs and then dies down	Partial loss of line voltage	Check for loose connections. Determine adequacy of main power supply.
Motor does not come up to speed	Low voltage at motor terminals	Check across AC line and correct voltage loss if possible.
	Line wiring to motor too small	Replace with larger sized wiring.
Motor overheats	Overloaded motor	Reduce load or replace with a larger motor.
	Motor fan is clogged with dirt preventing proper ventilation	Remove fan cover, clean fan and replace cover.
Excessive motor noise	Motor mounting bolts loose	Tighten motor mounting bolts.
	Rigid coupling connections	Replace with flexible connections.
	Worn motor bearings	Replace bearings and seals.
	Fan rubbing on fan cover	Remove interference in motor fan housing.

## Troubleshooting

**Table 20. Air handler troubleshooting recommendations (continued)**

Symptom	Probable Cause	Recommended Action
Low water coil capacity	Incorrect airflow	Check fan operating condition.
	Incorrect water flow	Inspect the water pumps and valves for proper operation and check the lines for obstructions.
	Incorrect water temperature	Adjust the chiller or boiler to provide the proper water temperature.
	Coil is piped incorrectly	Verify coil piping (see "Piping and Connections," p. 58).
	Dirty fin surface	Clean the fin surface (see "Coils," p. 89).
	Incorrect glycol mixture	Verify glycol mixture and adjust if necessary.
Low refrigerant coil capacity Low steam coil capacity Drain pan is overflowing	Incorrect airflow	Check fan operating condition.
	Expansion valve is not operating properly or is sized incorrectly	Check sensing bulb temperature. Verify valve operation. Verify proper valve size.
	Incorrect refrigerant charge	Verify refrigerant charge and adjust if necessary.
	Condensing unit failure	Verify condensing unit operation.
	Coil is piped incorrectly	Verify coil piping (see "Piping and Connections," p. 58).
	Clogged refrigerant line filter	Change filter core.
	Failure of suction/liquid line components	Verify component operation
	Dirty fin surface	Clean the fin surface (see "Coils," p. 89). Do not use steam to clean refrigerant coils.
	Fin frosting	Verify defrost cycle operation. Verify frostat operation. Verify refrigerant charge.
	Incorrect airflow	Check fan operating condition.
	Coil is piped incorrectly	Verify coil piping (see "Piping and Connections," p. 58).
	Incorrect steam pressure	Verify steam pressure and adjust if necessary.
	Excessive steam superheat	Check steam superheat. Steam superheat should not exceed 50°F.
	Failure of steam line/condensate return components	Verify component operation
	Boiler failure	Verify boiler operation
	Dirty fin surface	Clean the fin surface (see "Coils," p. 89).
	Plugged Drain Line	Clean drain line
	Unit not level	Level unit
	Improper trap design	Design trap per unit installation instructions
Standing water in drain pan	Improper trap design	Design trap per unit installation instructions
	Unit not level	Level unit
	Plugged drain line	Clean drain line
Wet interior	Coil face velocity too high	Reduce fan speed
	Improper trap design	Design trap per unit installation instructions
	Drain pan leaks/overflows	Repair leaks
	Condensation on surfaces	Insulate surfaces
Excess dirt in unit	Missing filters	Replace filters
	Filter bypass	Reduce filter bypass by ensuring all blockoffs are in place.

**Table 20. Air handler troubleshooting recommendations (continued)**

<b>Symptom</b>	<b>Probable Cause</b>	<b>Recommended Action</b>
Microbial growth (mold) inside air handler	Standing water in drain pan	See "Standing water in drain pan" above
UV light fails	Ballast fails to energize light	Disconnect high voltage leads (green, white, and black connectors) from the ballast enclosure. Wait for three minutes, this will reset the end-of-light circuitry and then reconnect.
	End of life	Replace bulb. See "Replacing the Bulbs," p. 94.



Notes

---



Trane - by Trane Technologies (NYSE: TT), a global innovator - creates comfortable, energy efficient indoor environments for commercial and residential applications. For more information, please visit [trane.com](https://trane.com) or [tranetechnologies.com](https://tranetechnologies.com).

Trane has a policy of continuous product and product data improvements and reserves the right to change design and specifications without notice. We are committed to using environmentally conscious print practices.

CLCH-SVX018D-EN 01 Jul 2026  
Supersedes CLCH-SVX018C-EN (December 2025)

©2026 Trane