



Installation, Operation, and Maintenance Performance Climate Changer™

Air Handlers

Model CSAA

Sizes 3 to 120

Indoor and Outdoor Applications



⚠ SAFETY WARNING

Only qualified personnel should install and service the equipment. The installation, starting up, and servicing of heating, ventilating, and air-conditioning equipment can be hazardous and requires specific knowledge and training. Improperly installed, adjusted or altered equipment by an unqualified person could result in death or serious injury. When working on the equipment, observe all precautions in the literature and on the tags, stickers, and labels that are attached to the equipment.

July 2026

CLCH-SVX016D-EN

TRANE
TECHNOLOGIES



Introduction

Read this manual thoroughly before operating or servicing this unit.

Warnings, Cautions, and Notices

Safety advisories appear throughout this manual as required. Your personal safety and the proper operation of this machine depend upon the strict observance of these precautions.

The three types of advisories are defined as follows:



Indicates a potentially hazardous situation which, if not avoided, could result in death or serious injury.



Indicates a potentially hazardous situation which, if not avoided, could result in minor or moderate injury. It could also be used to alert against unsafe practices.



Indicates a situation that could result in equipment or property-damage only accidents.

Important Environmental Concerns

Scientific research has shown that certain man-made chemicals can affect the earth's naturally occurring stratospheric ozone layer when released to the atmosphere. In particular, several of the identified chemicals that may affect the ozone layer are refrigerants that contain Chlorine, Fluorine and Carbon (CFCs) and those containing Hydrogen, Chlorine, Fluorine and Carbon (HCFCs). Not all refrigerants containing these compounds have the same potential impact to the environment. Trane advocates the responsible handling of all refrigerants.

Important Responsible Refrigerant Practices

Trane believes that responsible refrigerant practices are important to the environment, our customers, and the air conditioning industry. All technicians who handle refrigerants must be certified according to local rules. For the USA, the Federal Clean Air Act (Section 608) sets forth the requirements for handling, reclaiming, recovering and recycling of certain refrigerants and the equipment that is used in these service procedures. In addition, some states or municipalities may have additional requirements that must also be adhered to for responsible management of refrigerants. Know the applicable laws and follow them.

⚠ WARNING

Proper Field Wiring and Grounding Required!

Failure to follow code could result in death or serious injury.

All field wiring **MUST** be performed by qualified personnel. Improperly installed and grounded field wiring poses **FIRE** and **ELECTROCUTION** hazards. To avoid these hazards, you **MUST** follow requirements for field wiring installation and grounding as described in **NEC** and your local/state/national electrical codes.

⚠ WARNING

Personal Protective Equipment (PPE) Required!

Failure to wear proper PPE for the job being undertaken could result in death or serious injury.

Technicians, in order to protect themselves from potential electrical, mechanical, and chemical hazards, **MUST** follow precautions in this manual and on the tags, stickers, and labels, as well as the instructions below:

- **Before installing/servicing this unit, technicians MUST put on all PPE required for the work being undertaken (Examples; cut resistant gloves/sleeves, butyl gloves, safety glasses, hard hat/bump cap, fall protection, electrical PPE and arc flash clothing). ALWAYS refer to appropriate Safety Data Sheets (SDS) and OSHA guidelines for proper PPE.**
- **When working with or around hazardous chemicals, ALWAYS refer to the appropriate SDS and OSHA/GHS (Global Harmonized System of Classification and Labelling of Chemicals) guidelines for information on allowable personal exposure levels, proper respiratory protection and handling instructions.**
- **If there is a risk of energized electrical contact, arc, or flash, technicians MUST put on all PPE in accordance with OSHA, NFPA 70E, or other country-specific requirements for arc flash protection, PRIOR to servicing the unit. NEVER PERFORM ANY SWITCHING, DISCONNECTING, OR VOLTAGE TESTING WITHOUT PROPER ELECTRICAL PPE AND ARC FLASH CLOTHING. ENSURE ELECTRICAL METERS AND EQUIPMENT ARE PROPERLY RATED FOR INTENDED VOLTAGE.**

⚠ WARNING**Follow EHS Policies!**

Failure to follow instructions below could result in death or serious injury.

- All Trane personnel must follow the company's Environmental, Health and Safety (EHS) policies when performing work such as hot work, electrical, fall protection, lockout/tagout, refrigerant handling, etc. Where local regulations are more stringent than these policies, those regulations supersede these policies.
- Non-Trane personnel should always follow local regulations.

⚠ WARNING**Cancer and Reproductive Harm!**

This product can expose you to chemicals including lead and bisphenol A (BPA), which are known to the State of California to cause cancer and birth defects or other reproductive harm. For more information go to www.P65Warnings.ca.gov.

⚠ WARNING**R-454B or R-32 Flammable A2L Refrigerant!**

Failure to use proper equipment or components as described below could result in equipment failure, and possibly fire, which could result in death, serious injury, or equipment damage.

The equipment described in this manual uses R-454B or R-32 refrigerant which is flammable (A2L). Use **ONLY** R-454B or R-32 rated service equipment and components. For specific handling concerns with R-454B or R-32, contact your local representative.

⚠ WARNING**Electrical Shock Hazard!**

Failure to follow instructions below could result in death or serious injury.

Properly connect the system's oversized protective earthing (grounding) terminal(s).

NOTICE**Equipment Damage!**

Failure to follow instructions below could result in equipment damage.

This unit is a partial unit air conditioner, complying with partial unit requirements of standards listed, and must only be connected to other units that have been confirmed as complying to corresponding **PARTIAL UNIT** requirements of these Standards: UL 60335-2-40/CSA C22.2 No. 60335-2-40, or UL 1995/CSA C22.2 No 236.

Additional Environmental Information

Air handler foamed panels rely on a foam system that utilizes water and R-1233zd as blowing agents.

Copyright

This document and the information in it are the property of Trane, and may not be used or reproduced in whole or in part without written permission. Trane reserves the right to revise this publication at any time, and to make changes to its content without obligation to notify any person of such revision or change.

Trademarks

All trademarks referenced in this document are the trademarks of their respective owners.

Revision History

Updated seismic information.



Table of Contents

General Information	7	Ignition Sources in Ductwork	25
Overview of Manual	7	Ignition Sources in Unit	25
Nameplate	7	Minimum Room Area Limits(R-454B charge greater than 3.91 lb per circuit or R-32 charge greater than 4.04 lb per circuit)	25
Operating Environment	7	Leak Detection System (R-454B charge greater than 3.91 lb per circuit or R-32 charge greater than 4.04 lb per circuit)	28
Unit Description	7	Field Piping Installation and Charging	29
Components	7	Installation — Mechanical	30
Factory-Mounted Controls	7	Lifting and Rigging	30
Pre-Packaged Configurations for Controls	7	Remove Shipping Tie Downs	30
Wiring	8	DDP Fan Thrust Bumper	31
Pre-Installation	9	General Lifting Considerations	31
Receiving and Handling	9	Split to Split Orientation Instructions	33
Inspection	9	Units with Split Indicators on Side Baserails	33
Packaging/Shipping	9	Units with Split Indicators on Perpendicular Baserails	34
Identification	9	Lifting Hoods and Pipe Cabinets	35
Handling	9	Forklifting Considerations	35
Receiving Checklist	9	Unit Placement and Assembly	35
Jobsite Storage	9	Removing the Shipping Skid	36
Outdoor Storage	10	Ceiling Suspension	37
Long-Term Storage	10	Shipping Gussets	37
Site Preparation	10	Section-to-Section Assembly	38
Roof Curb Installation Checklist	11	Pipe Cabinet Installation	46
Dimensions and Weights	12	Hood Installation	49
Installation Clearances (Electric Heat)	12	Stacked Outdoor Unit Assembly	51
Service Clearance Recommendations	12	Dual-Path SDU/Winterizer Assembly	59
Section Dimensions and Weights	14	External Raceway Assembly	61
Fans/Motors	21	Seismic Application Requirements	62
Starter/VFD Weights	21	Single Level Design – Size 3 to 120	62
Motor Weights	21	Stacked Design – Size 3 to 50	63
A2L Information and Installation Requirements	22	Anchoring	64
Installation/Code Compliance Requirements	22	Hurricane Application Requirements	64
A2L Work Procedures	22	Miami/Dade Co. Hurricane Certification	64
Servicing	22	Anchoring	64
Leak Detection	23	Gas Heat Installation	68
Refrigerant Removal and Evacuation	23	Pipe Cabinet Installation	68
Refrigerant Charging	24		
Decommissioning	24		
A2L Application Considerations	24		

Component Installation	72	Expansion Valves.....	112
Dampers	72	Hot Gas Bypass.....	112
Damper Torque Requirements	72	Humidifier Piping and Connections.....	112
Opposed-Blade/Parallel-Blade Damper.....	80	Remodel, Retrofit, or Replacement.....	113
Diffusers	81	Field-Installed Evaporator Piping	114
Fans.....	81	Installation - Electrical.....	119
Fan Isolation	82	Motorized Impeller Control Panel	119
Adjusting the Isolators	82	Motorized Impeller Control Panel with Hand Off Auto Switch.....	120
Filters	83	Quick Connects	121
Final Filter Section	83	CDQ™ Desiccant Wheel Cassette/Motor	121
Pre-Filter Section	83	Optional Damper Actuators.....	121
Filter Installation	83	Typical Wiring Schematics	123
Filter Placement	84	Controls Interface.....	132
Duct Connections.....	101	Leak Detection Programming.....	132
Fan Discharge Connections.....	101	Operator Display	132
Damper Connections.....	102	Connecting the Operator Display	132
Bottom Opening Duct Installation	102	Calibrating the Operator Display	132
Discharge Plenum Connections	103	Adjusting Brightness and Contrast	133
Bell Mouth Discharge Connections.....	103	External Communications Port	133
TraQ Damper Connections	104	Start-Up.....	134
Other Connections.....	104	Pre-Start-up Checklist.....	134
Piping and Connections.....	106	General Checks	134
General Recommendations	106	Fan-Related Checks.....	134
Drain Pan Trapping	106	Coil-Related Checks.....	134
Steam Coil Piping.....	107	Motor-Related Checks	134
Water Coil Piping	108	Unit Operation	135
Refrigerant Coil Piping	109	Calculate Motor Voltage Imbalance	135
Liquid Lines.....	110	VFD Programming Parameters	135
Line Sizing	110	Airflow Measuring Systems	137
Routing	110	TraQ™ Dampers	137
Insulation	110	Fan Inlet Airflow Measuring System	140
Components	110	Wiring	141
Suction Lines	111	Transmitter Sizing.....	141
Line sizing	111	Transmitter Calibration.....	141
Routing	111	Maintenance	141
Avoid Underground Refrigerant Lines.....	111	Constant Factor K	141
Insulation	112		
Components	112		

CDQ Wheel Start Up	143	Segment Removal - 900-15,000 wheel cfm	156
Energy Wheel Start-up	144	Segment Replacement - 900-15,000 wheel cfm	157
External Insulating Requirements	145	Segment Removal - 17,500 and higher wheel cfm	157
Routine Maintenance	146	Removal Procedure for Outer Segments	158
Maintenance Checklist	146	Removal Procedure for Inner Segments	158
Air-to-Air Plate Heat Exchangers	147	Segment Replacement - 17,500 and higher wheel cfm	158
Coils	147	Installation Procedure for Inner Segments	158
Steam and Water Coils	147	Installation Procedure for Outer Segments	158
Refrigerant Coils	148	Energy Wheel Bearings/Motor/Belts	159
Coil Winterization	149	Energy Wheel Bearing/Drive Belt	159
Moisture Purge Cycle	149	Bearing/Drive Belt Replacement for Sizes 10- 50	159
Drain Pans	149	Energy Wheel Seal Adjustment	160
CDQ Desiccant Dehumidification		Energy Wheel Drive Motor and Pulley Replacement	160
Wheel	150	Fans	161
CDQ Cleaning	150	Bearing Set Screw Alignment	161
Vacuuming the Wheel	150	Torque Requirements	161
Washing the Wheel	150	Fan Bearing Lubrication	161
Cleaning the Motor	150	Motor Bearing Lubrication	162
Cleaning the Module	150	Fan Motor Inspection	162
CDQ Bearings/Motor/Belts	150	Fan Block-off Plate	162
CDQ Bearing and Motor Lubrication	150	Filters	163
CDQ Drive Belt Tension	150	Throwaway Filters	163
CDQ Bearing Replacement	151	Permanent Filters	163
CDQ Internal Bearing Replacement	151	Moisture Eliminator	163
CDQ External Bearing Replacement	152	Cartridge or Bag Filters	163
CDQ Drive Belt Adjustment/ Replacement	154	Ultraviolet (UV) Light Maintenance	163
CDQ Belt Tension	154	Cleaning the Bulbs	164
CDQ Seal Adjustment	155	Replacing the Bulbs	164
CDQ Drive Motor and Pulley Replacement	155	Disposal of Bulbs	165
Energy Wheels	156	Troubleshooting	166
Energy Wheel Cleaning	156		
Cleaning the Energy Wheel Motor	156		
Cleaning the Module	156		
Segment Removal and Replacement	156		



General Information

Overview of Manual

Use this manual to install, start-up, operate, and maintain the Performance Climate Changer™ air handler model CSAA. Carefully review the procedures discussed in this manual to minimize installation and start-up difficulties.

Nameplate

Each air handler section includes one or more a nameplates or labels which identify the type of section and functional components, customer tagging information, unit serial number, unit sales order number, installation build section position, and unit model number.

Note: *Serial number and sales order number are required when requesting service or parts.*

Operating Environment

The Performance Climate Changer™ air handler is a central station air handler for indoor and outdoor applications. When considering the placement of the air handler, it is important to consider the operating environment. The acceptable ambient temperature range for unit operation is -40°F to 140°F (-40°C to 60°C).

For heating applications, a special motor may be required to withstand the higher temperatures. Motors with Class B insulation are acceptable for ambient temperatures up to 104° F, while motors with Class F insulation can withstand ambient temperatures to +140° F (60° C).

Note: *Units with UL approval have a maximum ambient temperature requirement of 104°F. The customer should provide adequate freeze protection for the coils. See "Routine Maintenance," p. 146.*

Unit Description

The Performance Climate Changer air handler is designed for a variety of controlled-air applications. The basic unit consists of a fan, heating and/or cooling coils, filters, and dampers.

Components

Trane air handlers ship as complete assemblies or in sub-assemblies if shipping splits are required. Some assembly is required when the unit ships in subassemblies.

A wide variety of components is available for Trane air handlers, including numerous fan, coil, and filter options, access sections, diffusers, discharge plenums, face-and-bypass sections, UL-approved electric heat sections, humidity management options, energy recovery options, mixing boxes, moisture eliminator sections, exhaust dampers, controls, blenders and airflow monitoring stations.

For more information, see the following documents, available from your local Trane sales engineer:

- *Performance Climate Changer™ CSAA Air Handlers Product Catalog (CLCH-PRC022*-EN)*
- *Performance Climate Changer™ CSAA Air Handlers Product Catalog (CLCH-PRC023*-EN)*
- *Performance Climate Changer™ Air Handler Quick Select (CLCH-PRC016*-EN)*
- *Roof Curbs for Performance Climate Changer™ Air Handlers Installation Instructions (CLCH-SVN05*-EN)*
- *Gas Heat Performance Climate Changer™ CSAA Air Handlers Installation, Operation, and Maintenance (CLCH-SVX08*-EN)*
- *Gas Heat — Inshot Style Performance Climate Changer™ CSAA Air Handlers Installation, Operation, and Maintenance (CLCH-SVX014*-EN)*
- *Air Heating and Cooling Coils Installation, Operation, and Maintenance (COIL-SVX01*-EN)*

Factory-Mounted Controls

Trane air handlers are available with a wide selection of factory-mounted controls, including controllers, motor starters, and variable frequency drives (VFD).

Most control components are mounted inside the unit. Depending on the system configuration, this may include damper actuators, dirty filter switches, averaging temperature sensors, and low limit switches. VFDs, starters, controllers, control transformers, static pressure transducers, DC power supplies, and customer interface relays will be in enclosures mounted on the inside of the unit.

Small items that cannot be factory-mounted, such as space temperature sensors, outside air temperature sensors, and humidity sensors, will ship inside the control enclosures, or packaged and shipped inside the fan or mixing box section. Larger items are shipped inside the fan section.

Note: *All control valves ship directly to the ship-to address from the vendor unless another address is given on the Trane sales order.*

All factory-mounted control systems (controls that are factory-wired to a unit controller ordered without motor interface option such as VFD/MICP are provided with 120 to 24 Vac control transformers mounted and wired in the auxiliary control panel. The customer must provide 120 Vac control power, 50/60 Hz, typically 3 amps for unit sizes 3 to 57 and 5 amps for unit sizes 66 to 100. A dedicated 15-amp circuit is recommended. Factory-mounted control systems ordered with factory-mounted starters or VFDs are supplied with line to 24 Vac control transformers. No additional power wiring is required.

Pre-Packaged Configurations for Controls

If the air handler has been selected using one of Trane's pre-packaged solutions options for controls, there are a



General Information

number of resources available to aid in commissioning and start-up of the unit. These resources include commissioning sheets, graphics and technical application notes. The technical application notes include the control sequencing, Trane Graphic Programming (TGP) and Rover set-up files for the specific unit selected. These resources are available through your local Trane sales office.

For more information on controls, see the following manuals:

- Programmable Symbio™ 500 controllers
 - *Symbio™ 500 Programmable Controller Installation, Operation, and Maintenance* (BAS-SVX090*-EN)
 - *Installing the Tracer TD-7 Display* (X39641191-01A)
- TR150 Drives
 - *TR150 and TR170 Design Guide* (BAS-SVX59*-EN)
 - *TR150 and TR170 Programming Guide* (BAS-SVP16*-EN)

Wiring

⚠ WARNING

Proper Field Wiring and Grounding Required!

Failure to follow code could result in death or serious injury.

All field wiring **MUST** be performed by qualified personnel. Improperly installed and grounded field wiring poses **FIRE** and **ELECTROCUTION** hazards. To avoid these hazards, you **MUST** follow requirements for field wiring installation and grounding as described in NEC and your local/state/national electrical codes.

⚠ WARNING

Electrical Shock Hazard!

Failure to follow instructions below could result in death or serious injury.

Properly connect the system's oversized protective earthing (grounding) terminal(s).

Entrances are generally provided for field-installation of high and low voltage wiring through a pipe/nipple connection in the unit depending on unit configuration with or without factory-mounted controls. Before installation, consider overall unit serviceability and accessibility before mounting, running wires (power), making penetrations, or mounting any components to the cabinet.

Wiring to the air handler must be provided by the installer and must comply with all national and local codes. The fan motor nameplate includes a wiring diagram. If there are any questions concerning the wiring of the motor, write down the information on the motor nameplate and contact your local Trane sales office.



Pre-Installation

Receiving and Handling

Inspection

Upon delivery, thoroughly inspect all components for any shipping damage that may have occurred, and confirm that the shipment is complete. See “Receiving Checklist,” p. 9 section for detailed instructions.

Note: *Delivery cannot be refused for any reason. All units are shipped F.O.B. factory. Trane is not responsible for freight damage when shipped F.O.B. factory.*

Packaging/Shipping

Performance air handlers ship as a complete unit or in individual sections to be field assembled. Indoor air handler sections are stretch-wrapped or shrink-wrapped before shipping. All factory shipping protection should be removed upon delivery. This wrapping is for transit protection only.

Indoor Performance air handlers ship in sub-assemblies if the total length of the units exceeds 98-inches or if the total weight exceeds the limits shown in Table 1, p. 9.

Note: *These limits are based on a four-point lift.*

Table 1. Shipping length and weight limitations for indoor air handlers

Unit Size	Maximum Unit Length (in)	Maximum Unit Weight (lb.)
3–31	98	<2,500
35, 36	98	<3,900
40	98	<4,300
50–57	98	<5,100
66–120	98	<8000

Outdoor Performance air handler sections are not wrapped, but openings are covered to comply with LEED EQ Credit 5. Table 2, p. 9 outlines weight and length shipping limits for outdoor air handler sections.

Table 2. Shipping length and weight limitations for outdoor air handlers

Unit Size	Min Length (in)	Max Length (in)	Max Weight (lbs)
3–30	24.50	360.00	8,000
35–57	24.50	96.00	12,000
66	24.50	107.00	12,000
80	24.50	115.00	12,000
100	24.50	118.50	12,000
120	24.50	118.50	12,000

Smaller components and hardware may be shipped separately, or shipped inside the unit. This hardware is

typically packaged in a clear plastic envelope or cardboard box, and can be found inside the fan, mixing box, or access section.

Identification

Each air handler section includes a nameplate identifying the section type and functional components, customer tagging information, unit serial number, unit order number, the build-section position for installation, and the unit model number. See “Nameplate,” p. 7.

Handling

Air handlers have an integral base frame designed with the necessary number of lift points for safe installation. See “Lifting and Rigging,” p. 30.

Indoor air handlers sizes 3 to 30 are shipped with a shipping skid designed for forklift transport.

Receiving Checklist

Complete the following checklist immediately after receiving shipment to detect possible shipping damage.

- Check to ensure that the shipment is complete. Small components may ship inside the unit or ship separately. Check the parts list to ensure all materials are present. If any component is missing, contact your local Trane sales office.
- Check all units, components, connections, and piping. Check fan wheel for free rotation by spinning manually. Check all doors, latches and hinges. Inspect interior of each unit or section. Inspect coils for damage to fin surface and coil connections. Check for rattles, bent corners, or other visible indications of shipping damage. Tighten loose connections.
- If a unit is damaged, make specific notations concerning the damage on the freight bill. Do not refuse delivery.
- Notify the carrier’s terminal of the damage immediately by phone and mail. Request an immediate joint inspection of the damage by the carrier and consignee.
- Inspect the unit for concealed damage as soon as possible after delivery. Report concealed damage to the freight line. It is the receiver’s responsibility to provide reasonable evidence that concealed damage did not occur after delivery. Take photos of damaged material if possible.

Note: *Concealed damage must be reported to the Freight Carrier in writing within 5 business days of receipt.*

Jobsite Storage

Indoor air handlers and field-installed accessories must be protected from the elements. A controlled indoor environment is recommended for proper storage.

Note: *All factory shipping protection should be removed, This wrapping is for transit protection only.*

The unit controller and all other electrical/electronic components should be stored in conditions of -20°F to 120°F and 5 to 95 percent relative humidity, non-condensing. Electrical components are not moisture-tolerant.



Pre-Installation

Outdoor units require no special protection for storage prior to installation.

Outdoor Storage

NOTICE

Unit Corrosion Damage!

Plastic tarps can cause condensation to form in and on the equipment, which could result in corrosion damage or wet storage stains.

Use only canvas tarps to cover equipment.

Outdoor storage is not recommended for units that will be installed indoors. However, when outdoor storage is necessary, several things must be done to prevent damage:

Note: *Keep the equipment on the original wooden blocks/skid for protection and ease of handling.*

- Select a well-drained area, preferably a concrete pad or blacktop surface.
- Place the unit on a dry surface or raised off the ground to assure adequate air circulation beneath the unit and to assure no portion of the unit will contact standing water at any time.
- Loosen the belt tension on the drive belts.
- Cover the unit securely with a canvas tarp.
- Do not stack units.
- Do not pile other material on the unit.

Long-Term Storage

For longer periods of storage, allow proper clearance around the unit to perform periodic inspections and maintenance on the equipment. While the unit is in storage:

- Every two weeks, rotate the fan and motor shaft 30 revolutions by hand. Check for free rotation.
- Every six months, check fan shaft bearings and grease lines. Add grease using a manual grease gun following the lubrications recommendations in “[Fan Bearing Lubrication](#),” p. 161.
- Check the motor lubrication; remove and clean grease plugs and check for the presence of moisture in the grease. If moisture is present, remove the motor and send it to an authorized repair shop for bearing inspection/replacement. If no moisture is present, refer to the motor manufacturer’s lubrication recommendation for proper lubrication.

Site Preparation

- Confirm the installation site can support the total weight of the unit (see “[Dimensions and Weights](#),” p. 12 for approximate section weights; see the unit submittals for actual weights).
- Allow sufficient space for adequate free air and necessary service access (see “[Service Clearance](#)

[Recommendations](#),” p. 12). See the submittals for specific minimums.

- Allow room for supply and return piping, ductwork, electrical connections, and coil removal.
- Verify adequate height for condensate drain requirements. See “[Drain Pan Trapping](#),” p. 106.

Note: *If unit is installed in a mechanical room on a pad, inadequate height may necessitate core-drilling the floor to attain proper trap height. Insufficient height could inhibit condensate drainage and result in flooding the unit and/or equipment room.*

NOTICE

Microbial Growth!

Failure to follow instructions below could result in odors and damage to the equipment and building materials.

The floor or foundation must be level and the condensate drain at the proper height for proper drainage and condensate flow. Standing water and wet surfaces inside the equipment can become an amplification site for microbial growth (mold). If there is evidence of microbial growth on the interior insulation, it should be removed and replaced prior to operating the system.

- Confirm the roof curb or foundation of the mounting platform is level and large enough to accommodate the unit. See the unit submittals for specific dimensions.
- Provide adequate lighting for maintenance personnel to perform maintenance duties.
- Provide permanent power outlets in close proximity to the unit for installation and maintenance.
- Depending upon job requirements, 120 Vac power may need to be provided for the unit controller. See the submittals for more information. A dedicated 15-amp circuit is recommended.
- Wiring for the air handler must be provided by the installer and must comply with all national and local electrical codes.
- If the unit integral base frame ceiling suspension provisions are not used, the installer/contractor must provide a ceiling-suspended mounting frame designed to support the length, width, and weight of the entire air-handling unit. See “[Ceiling Suspension](#),” p. 37.
- Rooftop curb-mounted units must be sealed tightly to the curb. Use proper sealants and roof-to-curb sealing techniques to prevent water and air leakage. See the *Roof Curbs for Performance Climate Changer™ Air Handlers Installation Instructions* (CLCH-SVN05*-EN).

Note: *Preparation of the roof curb or pier mount and roof openings should be completed prior to lifting the unit to the roof.*

Roof Curb Installation Checklist

See *Roof Curbs for Performance Climate Changer™ Air Handlers Installation Instructions* (CLCH-SVN05*-EN) for information on installing roof curbs.

It is recommended that the curb be installed directly on the support members and fastened to the supports using tack welds or other equivalent methods. Properly supported decking should be installed inside the air handler section of the curb when this method is used. See [Figure 1, p. 11](#).

Figure 1. Cross section of typical curb installation on new construction

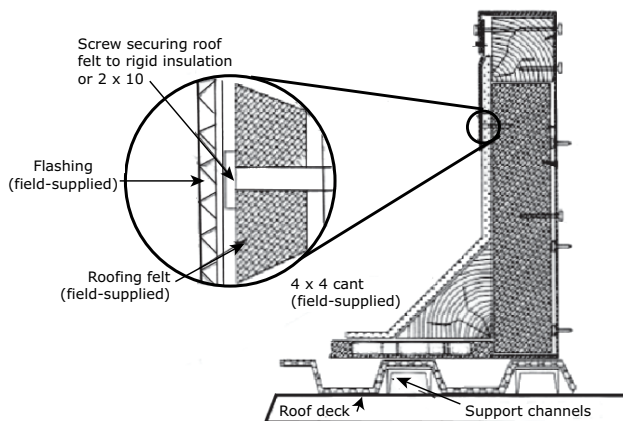

1. Verify that the roof structure can adequately support the combined weight of the unit and curb assembly.
2. Ensure that the selected installation location provides sufficient service and operational clearances.
3. Remove any twist within the curb due to roof supports and square the curb.
4. Level the curb.
5. Secure the curb to the roof support members.
6. Install 2-inch thick boards or rigid insulation around the curb.
7. Install cant strips around the curb.
8. Bring field supplied roofing felt up to the top of the curb nailing strips. Nail felt into place.
9. Install field supplied flashing under the lip of the curb flanges and over the felt.
10. Apply sealant to the four corners.
11. Caulk all joints between the curb and the roof.
12. Attach the gasket material to the curb's top flanges (entire perimeter) and to the supply and return air duct opening panel flanges.



Dimensions and Weights

Installation Clearances (Electric Heat)

Table 3. Electric heat requirements

Electric Heat Model	Minimum Clearance to Combustible Materials (inch)	Maximum Output Air Temperature (°F)	Maximum External Static Pressure (WC)
Draw-thru	0	104	—
Blow-thru	3 (first four feet of duct — duct, through transitions and turns)	200	—
	0 (after first four feet of duct)		
Duct Mounted	3 (first four feet of duct)	200	4

Service Clearance Recommendations

A minimum clearance of the section width plus 12-inches on the access door side of the gas heat section is

recommended for routine maintenance. This clearance provides enough room to replace the heat exchanger in the event of failure. The section side panels must be removed to access the heat exchanger. See the following figure for service clearance recommendations for the air handler.

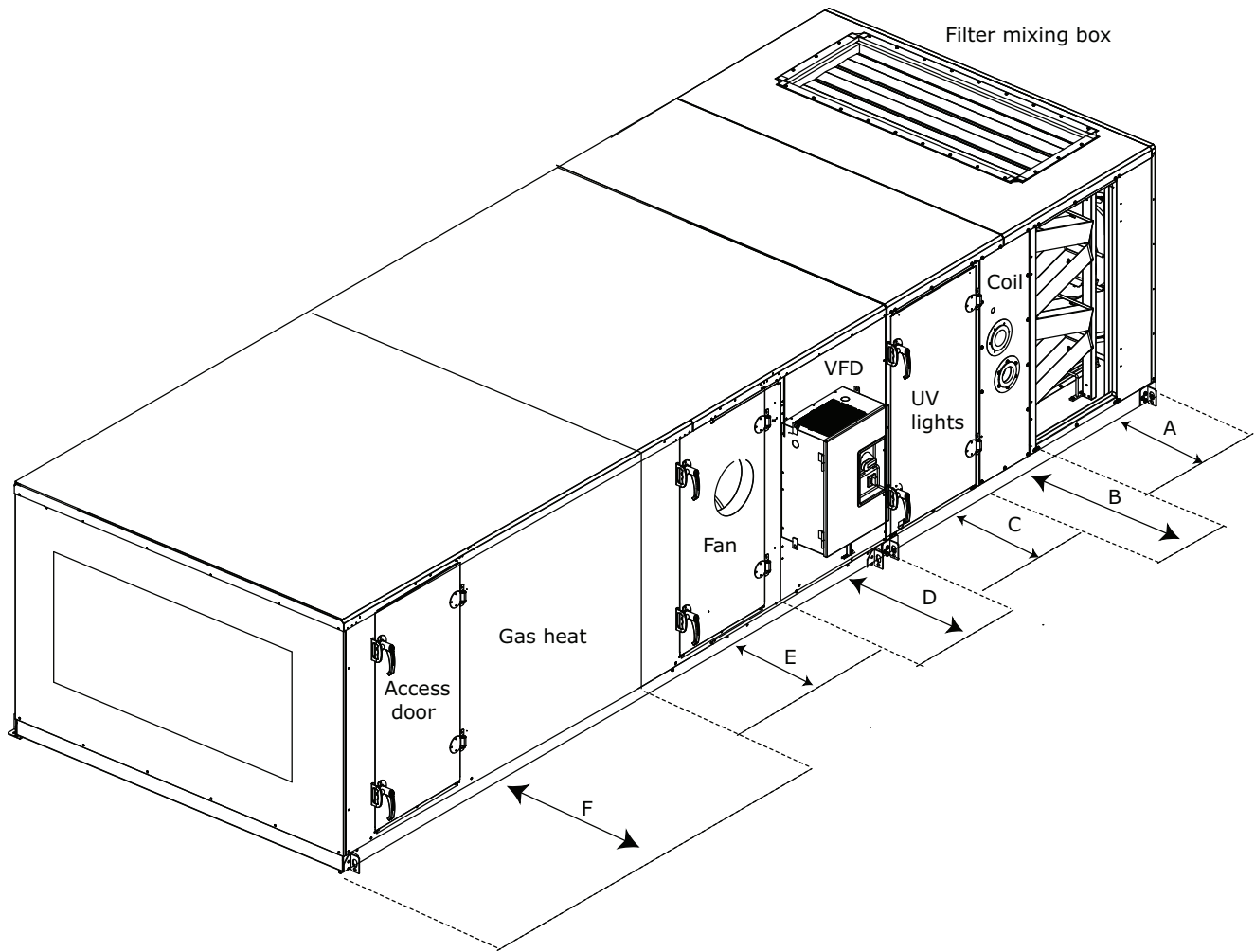
Figure 2. Service clearance for indoor units

Table 4. Service clearance dimensions (inches)

Component	3	4	6	8	10	12	14	17	21	25	30	35	40	50	57	66	80	100	120
A (filter)	48	48	48	48	48	48	48	48	48	48	48	48	48	48	48	52	56	58	58
B (coil, humidifier)	48	59	59	66	77	82	87	87	95	95	109	115	128	141	141	156	156	170	197
C (UV Lights)	48	48	48	48	48	48	48	48	48	48	48	48	48	48	48	52	56	58	58
C (TCAPS)	48	48	48	48	48	48	48	48	48	48	48	48	48	48	48	52	56	58	58
D (external motor control or low voltage panel)	61	61	61	61	61	61	61	61	64	64	64	64	64	64	64	64	64	64	64
D (VFD)	48	48	48	48	48	48	48	48	48	48	48	48	48	48	48	48	48	48	48
E (fan)	48	48	48	48	51	54	58	61	60	66	66	66	70	77	77	93	93	101	101
E (fan - MI Array)	25	25	25	25	32	32	32	32	32	32	32	32	32	32	32	32	32	32	32
F (gas heatExt Vestibule)	—	—	89	90	108	100	100	105	115	115	118	136	140	156	156	170	179	180	—



Dimensions and Weights

Table 4. Service clearance dimensions (inches) (continued)

Component	3	4	6	8	10	12	14	17	21	25	30	35	40	50	57	66	80	100	120
F (gas heat/nt Vestibule)	—	—	56	63	74	79	84	84	92	92	106	112	125	138	138	153	153	167	194

Note: At a minimum, the above clearance dimensions are recommended on one side of the unit for regular service and maintenance. Refer to as-built submittal for locations of items such as filter access doors, coil, piping connections, motor locations, hoods, pipe cabinets, etc. Sufficient clearance must be provided on all sides of unit for removal of access panels, plug panels, or section-to-section attachment brackets. Clearance for starters, VFDs, or other high-voltage devices must be provided per NEC requirements. For specific dimensional and weight information, refer to the unit submittals. The dimensions and weights in this manual are approximate. Trane has a policy of continuous product and product data improvement and reserves the right to change design and specifications without notice.

Figure 3. Service clearance for control box

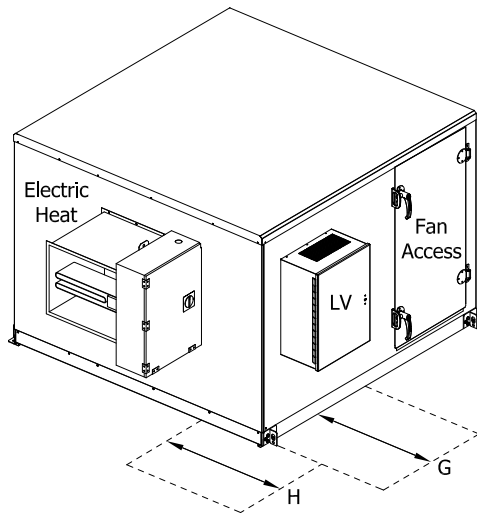

Table 5. Service clearance dimensions (inches) for control box

Component	Unit Size																		
	3	4	6	8	10	12	14	17	21	25	30	35	40	50	57	66	80	100	120
G (LV component)	36	36	36	36	36	36	36	36	36	36	36	36	36	36	36	36	36	36	36
H (electric heat duct mount)	48	48	48	48	48	48	48	48	48	48	48	—	—	—	—	—	—	—	—

Section Dimensions and Weights

Table 6. Section dimensions (inches) and weights (pounds) — unit sizes 3 to 30

Unit size	3	4	6	8	10	12	14	17	21	25	30
Nominal airflow	1500	2000	3000	4000	5000	6000	7000	8500	10,500	12,500	15,000
Airflow at 625 fpm	2169	3475	4338	4581	6075	8331	9025	11,806	13,456	16,944	19,025
Height - indoor unit	29.00	29.00	35.25	37.75	37.75	41.50	41.50	49.00	52.75	61.50	61.50
Width	31.50	44.00	44.00	50.50	61.50	66.50	72.00	72.00	80.00	80.00	93.50
Height for outdoor unit includes base drip lip	36.25	36.38	42.63	45.13	45.13	49.25	49.25	56.75	60.50	69.25	69.25
Weight add for outdoor unit (lbs/in. of unit length)	1.66	1.91	1.91	2.04	2.27	2.40	2.51	2.51	2.68	2.68	2.94

Table 6. Section dimensions (inches) and weights (pounds) — unit sizes 3 to 30 (continued)

Unit size	3	4	6	8	10	12	14	17	21	25	30
Access or blank											
-Small horizontal	10.00	10.00	10.00	10.00	10.00	10.00	10.00	10.00	10.00	10.00	10.00
	48.05	57.43	60.55	66.67	74.92	80.55	84.67	88.41	96.28	100.65	110.78
-Medium horizontal	14.00	14.00	14.00	14.00	14.00	14.00	14.00	14.00	14.00	14.00	14.00
	59.91	71.18	75.25	82.74	92.66	99.61	104.57	109.45	119.10	124.79	136.97
-Extended-medium horizontal	19.00	19.00	19.00	19.00	19.00	19.00	19.00	19.00	19.00	19.00	19.00
	74.73	88.37	93.62	102.82	114.83	123.43	129.44	135.74	147.62	154.97	169.71
-Medium-large horizontal	24.50	24.50	24.50	26.50	26.50	26.50	26.50	24.50	24.50	24.50	24.50
	121.60	107.28	113.84	132.94	148.08	159.18	166.74	164.66	178.99	188.17	205.72
-Large horizontal or turning	34.00	34.00	34.00	36.00	36.00	36.00	36.00	36.00	34.00	46.00	46.00
	137.75	164.85	179.46	208.50	235.01	257.70	271.35	293.42	314.60	413.45	457.18
-Extra-large horizontal or turning	36.00	41.00	41.00	44.00	42.50	42.50	42.50	44.00	50.25	56.50	56.50
	143.68	188.92	205.18	240.63	263.83	288.68	303.68	335.49	407.29	476.83	525.93
-Ducted inlet or ducted outlet section											
	10.00	10.00	10.00	10.00	10.00	10.00	10.00	10.00	10.00	10.00	10.00
	48.10	57.40	60.50	66.70	74.90	80.50	84.70	88.40	96.30	100.60	110.80
Blender											
	19.00	24.50	24.50	26.50	36.00	36.00	36.00	36.00	34.00	46.00	46.00
	94.86	132.71	146.30	173.34	238.64	264.12	276.73	303.71	323.59	427.13	470.25
Cool Dry Quiet (CDQ) Desiccant Dehumidification											
	52.00	52.00	52.00	52.00	55.00	58.00	58.00	58.00	56.00	56.00	58.00
	495.00	651.00	694.00	792.00	1011.00	1165.00	1326.00	1390.00	1793.00	1876.00	2029.00
Coils											
-Small horizontal (with 4-row UW)	10.00	10.00	10.00	10.00	10.00	10.00	10.00	10.00	10.00	10.00	10.00
	116.10	148.55	174.35	205.79	244.49	285.13	307.44	352.47	433.37	502.46	572.50
-Medium horizontal (with 8-row UW)	14.00	14.00	14.00	14.00	14.00	14.00	14.00	14.00	14.00	14.00	14.00
	168.65	220.23	265.58	318.97	382.53	450.07	488.32	569.79	700.27	817.63	941.48
-Extended-medium horizontal (with 8-row UW)	19.00	19.00	19.00	19.00	19.00	19.00	19.00	19.00	19.00	19.00	19.00
	185.58	239.53	286.06	341.16	406.80	476.00	516.35	599.24	737.96	858.03	985.30
-Medium-large horizontal (with 10-row W)	24.50	24.50	24.50	26.50	26.50	26.50	26.50	24.50	24.50	24.50	24.50
	270.61	359.79	433.08	554.88	656.63	777.26	884.93	1013.57	1262.10	1478.66	1503.93
-Large horizontal or vertical (with 10-row W)	34.00	34.00	34.00	36.00	36.00	36.00	36.00	36.00	34.00	46.00	46.00
	302.77	396.45	471.99	597.03	702.74	826.53	938.18	1081.30	1333.70	1652.36	1652.73
Electric Heat Coil											
	36.00	41.00	41.00	44.00	42.50	42.50	42.50	44.00	50.25	46.00	56.50
	295.00	364.00	413.00	480.00	563.00	622.00	666.00	731.00	876.00	1012.00	1244.00
Integral-face-and-bypass coil											
-Less than 4 rows	—	26.50	26.50	26.50	26.50	26.50	26.50	26.50	26.50	26.50	26.50
	—	355.20	367.21	470.21	541.93	585.86	619.66	733.14	792.88	805.52	940.46
-4 rows	—	43.00	43.00	43.00	43.00	43.00	43.00	43.00	43.00	43.00	43.00
	—	543.54	560.74	725.48	835.34	901.70	950.23	1131.90	1216.48	1399.66	1439.40
Controls section (with largest available VFD)											
	24.50	24.50	24.50	28.50	28.50	28.50	28.50	28.50	28.50	28.50	28.50
	184.00	208.00	253.00	272.00	295.00	315.00	327.00	350.00	428.00	453.00	487.00



Dimensions and Weights

Table 6. Section dimensions (inches) and weights (pounds) — unit sizes 3 to 30 (continued)

Unit size	3	4	6	8	10	12	14	17	21	25	30
Diffuser	10.00	10.00	10.00	14.00	14.00	14.00	14.00	14.00	14.00	19.00	19.00
	45.70	55.08	58.20	80.39	90.31	97.26	102.22	107.10	116.75	152.62	167.36
Discharge plenum											
-Horizontal	34.00	34.00	34.00	36.00	36.00	36.00	36.00	36.00	34.00	46.00	46.00
	135.40	162.50	177.11	206.15	232.66	255.35	269.00	291.07	312.25	411.10	454.83
-Vertical	36.00	41.00	41.00	44.00	42.50	42.50	42.50	44.00	50.25	56.50	56.50
	159.90	211.48	233.54	275.69	306.29	339.58	358.68	401.43	486.37	570.00	634.27
Energy Wheel	—	52.00	52.00	52.00	55.00	58.00	58.00	58.00	56.00	56.00	58.00
		609.00	663.00	765.00	911.00	1085.00	1208.00	1269.00	1484.00	1595.00	1868.00
Face-and-Bypass Dampers											
-Face-and-bypass	19.00	19.00	19.00	19.00	19.00	19.00	19.00	19.00	19.00	19.00	19.00
	105.60	129.06	141.70	157.63	178.68	199.15	209.53	224.50	248.05	265.62	291.36
-External face-and-bypass	19.00	19.00	19.00	19.00	19.00	19.00	19.00	19.00	19.00	19.00	19.00
	122.68	155.15	167.79	190.70	219.68	241.45	255.80	270.77	300.08	317.53	353.22
-Internal face-and-bypass or face damper only	19.00	19.00	19.00	19.00	19.00	19.00	19.00	19.00	19.00	19.00	19.00
	107.95	140.46	149.91	174.82	203.43	227.60	241.91	255.18	291.55	306.62	341.36
Filters											
-Side-load 2-in. angled	24.50	24.50	24.50	26.50	26.50	26.50	26.50	24.50	24.50	24.50	24.50
	134.55	163.83	175.66	202.44	225.96	251.82	265.94	314.12	347.50	403.70	454.19
-Side-load 4-in. angled	24.50	24.50	24.50	26.50	26.50	26.50	26.50	24.50	24.50	24.50	24.50
	141.89	176.87	192.86	209.64	247.16	254.22	273.54	352.07	379.13	409.37	465.65
-Side-load cartridge 12-in. or short bag 18-in.	24.50	24.50	24.50	26.50	26.50	26.50	26.50	24.50	24.50	24.50	24.50
	125.03	159.79	176.46	220.46	234.88	284.12	303.60	335.02	365.40	439.69	479.36
-Side-load 2-in. flat	14.00	14.00	14.00	14.00	14.00	14.00	14.00	14.00	14.00	14.00	14.00
	70.27	86.53	91.98	103.59	117.74	133.81	141.07	148.02	165.52	182.07	198.93
-Side-load 4-in. flat	14.00	14.00	14.00	14.00	14.00	14.00	14.00	14.00	14.00	14.00	14.00
	81.56	104.62	114.08	117.09	143.40	142.66	154.67	202.82	213.64	217.75	249.73
-Side-load 2-in. and 4-in. combination flat	19.00	19.00	19.00	19.00	19.00	19.00	19.00	19.00	19.00	19.00	19.00
	100.62	128.19	139.09	144.56	174.73	185.69	201.37	252.57	268.17	288.98	326.58
-Side-load long bag 30-in.	36.00	41.00	41.00	44.00	42.50	42.50	42.50	44.00	50.25	46.00	46.00
	159.54	203.31	223.70	269.26	289.43	330.97	349.19	382.94	461.96	488.89	523.37
-Front-load HEPA	40.00	40.00	40.00	40.00	40.00	40.00	40.00	40.00	40.00	40.00	40.00
	240.36	262.50	346.16	368.01	407.75	439.62	452.92	569.28	692.30	750.47	822.10
-Front-load cartridge	40.00	40.00	40.00	40.00	40.00	40.00	40.00	40.00	40.00	40.00	40.00
	215.15	237.79	285.59	310.12	341.11	386.04	399.01	470.25	525.86	580.13	651.47
-Front-load short bag	45.00	45.00	45.00	45.00	45.00	45.00	45.00	45.00	45.00	45.00	45.00
	222.35	246.75	279.75	306.39	335.16	369.65	383.67	432.15	473.60	518.05	566.55
Gas heat — Drum and Tube											
- 200 MBh	—	—	57.00	57.00	59.00	57.00	57.00	60.00	60.00	—	—
			752.92	797.85	852.48	912.57	937.05	1011.83	1074.91		

Table 6. Section dimensions (inches) and weights (pounds) — unit sizes 3 to 30 (continued)

Unit size	3	4	6	8	10	12	14	17	21	25	30
- 300 MBh	—	—	73.00 901.27	73.00 953.49	—	—	—	—	—	—	—
- 320/360 MBh	—	—	—	—	77.00 1093.23	73.00 1131.38	68.00 1127.89	71.00 1211.08	69.00 1264.50	69.00 1348.04	66.00 1298.88
- 560 MBh	—	—	—	—	—	—	—	71.00 1191.99	69.00 1246.59	65.00 1307.47	66.00 1441.79
- 700 MBh	—	—	—	—	—	—	—	83.00 1479.92	75.00 1503.43	75.00 1599.35	76.00 1745.65
- 860 MBh	—	—	—	—	—	—	—	—	81.00 1606.36	81.00 1711.24	76.00 1804.77
- 1000 MBh	—	—	—	—	—	—	—	—	87.00 1364.25	90.00 1497.35	85.00 1560.01
Gas heat — Inshot											
- 95 MBh	—	41.136 432	41.136 441	—	—	—	—	—	—	—	—
- 205 MBh	—	56.636 625	41.136 441	56.636 691	56.636 733	—	—	—	—	—	—
- 240 MBh	—	—	—	—	—	44.386 639	44.386 657	44.386 686	—	—	—
- 325 MBh	—	—	74.136 856	74.136 919	74.136 970	57.386 854	57.386 875	57.386 910	—	—	—
- 405 MBh	—	—	—	84.136 1027	84.136 1068	—	—	—	—	—	—
- 485 MBh	—	—	—	—	—	67.136 997	67.136 1021	67.136 1060	—	—	—
- 650 MBh	—	—	—	—	—	—	—	—	66.006 1348	66.006 1391	66.006 1453
- 970 MBh	—	—	—	—	—	—	—	—	81.006 1646	81.006 1695	81.006 1767
Humidifier											
-Building steam	14.00 125.00	14.00 146.00	14.00 165.00	14.00 184.00	14.00 226.00	14.00 269.00	14.00 286.00	14.00 324.00	14.00 354.00	14.00 398.00	14.00 452.00
-Atmospheric steam	14.00 127.00	14.00 168.00	14.00 178.00	14.00 203.00	14.00 252.00	14.00 276.00	14.00 312.00	14.00 339.00	14.00 396.00	14.00 432.00	19.00 528.00
Mixing box											
-with angled filters	34.00 137.75	34.00 164.85	34.00 179.46	36.00 208.50	36.00 235.01	36.00 257.07	36.00 271.35	36.00 293.42	34.00 314.60	46.00 413.45	46.00 457.18
-with front/back Traq and top Traq dampers	36.00 191.06	41.00 247.07	41.00 272.06	44.00 321.58	42.50 356.08	42.50 396.49	42.50 418.78	44.00 463.57	50.25 555.65	56.50 646.61	56.50 715.15



Dimensions and Weights

Table 6. Section dimensions (inches) and weights (pounds) — unit sizes 3 to 30 (continued)

Unit size	3	4	6	8	10	12	14	17	21	25	30
-reduced length with side/top/back/bottom airfoil damper	23.40	23.40	23.40	23.40	23.40	23.40	28.40	28.40	28.40	28.40	32.50
	131.80	158.30	177.90	202.80	231.60	257.60	298.40	328.40	370.10	408.10	485.80
Silencer											
-3 ft	38.00	38.00	38.00	38.00	38.00	38.00	38.00	38.00	38.00	38.00	38.00
	198.00	256.00	286.00	319.00	359.00	442.00	461.00	512.00	573.00	699.00	800.00
-5 ft	62.00	62.00	62.00	62.00	62.00	62.00	62.00	62.00	62.00	62.00	62.00
	308.00	391.00	436.00	483.00	541.00	678.00	704.00	780.00	873.00	1073.00	1215.00
UV light											
	14.00	14.00	14.00	14.00	14.00	14.00	14.00	14.00	14.00	14.00	14.00
	76.02	93.64	98.69	120.26	135.22	146.68	155.07	162.95	179.84	188.71	218.33
Trane Commercial Air Purification System (TCAPS)											
	24.00	24.00	24.00	24.00	24.00	24.00	24.00	24.00	24.00	24.00	24.00
	142.73	162.01	178.12	200.00	227.44	253.40	274.17	301.54	340.50	374.37	424.10
Pipe cabinet weight											
15 in. long, 36-in. deep	104.00	104.00	116.00	120.00	120.00	127.00	127.00	141.00	148.00	164.00	164.00
24 in. long, 36-in. deep	122.00	122.00	135.00	140.00	140.00	147.00	147.00	162.00	170.00	187.00	187.00
48 in. long, 36-in. deep	169.00	169.00	184.00	191.00	191.00	200.00	200.00	218.00	228.00	249.00	249.00
96 in. long, 36-in. deep	263.00	263.00	284.00	293.00	293.00	305.00	305.00	331.00	343.00	373.00	373.00

Notes:

- Nominal airflow is based on 500 fpm through a nominal coil (i.e. 500xunit size 8=4000 cfm).
- Airflow@625 fpm through the flat filter (maximum filter velocity).
- Height includes standard 2.5-inch base frame for sizes 3 to 57 and 6-inch base frame for sizes 66-120.
- Height includes 6-inch base frame for sizes 3-120.
- Variable lengths available from 14 to 96-inches.
- Nominal length and height shown for discharge plenums. Variable plenum height and length is available from 0.5 to 1.5 of nominal.
- Fan section weights include the heaviest fan with the largest ODP motor available.
- Access section required with humidifiers for dispersion distance.

Table 7. Section dimensions (inches) and weights (pounds) — unit sizes 31 to 120

Unit size	35	40	50	57	66	80	100	120
Nominal airflow	17,500	20,000	25,000	28,500	33,000	40,000	50,000	60,000
Airflow at 625 fpm	23,263	25,519	34,375	39,581	47,225	53,475	65,106	76,388
Height - indoor unit	67.25	67.25	75.75	85.50	92.50	107.50	119.75	119.75
Width	100.00	112.50	125.50	125.50	140.50	140.50	154.50	182.00
Height for outdoor unit includes base drip lip	75.00	75.00	84.38	94.13	97.63	112.63	124.88	124.88
Weight add for outdoor unit (lbs/in. of unit length)	3.02	3.28	3.73	6.12	2.57	2.57	2.80	3.25
Access or blank								
-Small horizontal	10.00	10.00	10.00	10.00	—	—	—	—
	211.11	227.92	254.69	265.35				
-Medium horizontal	14.00	14.00	14.00	14.00	15.00	15.00	15.00	15.00
	241.53	260.24	290.28	302.41	430.36	449.60	493.59	549.13
-Extended-medium horizontal	19.00	19.00	19.00	19.00	19.00	19.00	19.00	19.00
	279.57	300.64	334.76	348.74	476.36	497.88	545.85	605.56
-Medium-large horizontal	24.50	24.50	24.50	24.50	24.50	24.50	24.50	24.50
	321.40	345.09	410.37	427.50	574.11	600.46	656.89	725.47

Table 7. Section dimensions (inches) and weights (pounds) — unit sizes 31 to 120 (continued)

Unit size	35	40	50	57	66	80	100	120
-Large horizontal or turning	48.00 514.42	48.00 557.22	48.00 639.24	48.00 682.26	49.00 907.93	54.00 1036.33	60.00 1242.40	60.00 1387.96
-Extra-large horizontal or turning	63.75 624.86	63.75 675.12	68.50 809.42	—	—	—	—	—
-Ducted inlet or ducted outlet section	10.00 211.10	10.00 227.90	10.00 254.70	10.00 265.30	10.00 372.90	10.00 389.30	10.00 428.30	10.00 478.60
Blender	48.00 540.76	48.00 593.46	48.00 675.51	48.00 731.75	49.00 970.30	54.00 1112.23	60.00 1345.03	60.00 1567.62
Cool Dry Quiet (CDQ)	56.00	56.00	59.00	—	—	—	—	—
Desiccant Dehumidification	2914.00	3122.00	4224.00	—	—	—	—	—
Coils								
-Small horizontal (with 4-row UW)	10.00 690.59	10.00 754.61	10.00 934.27	10.00 1044.33	—	—	—	—
-Medium horizontal (with 8-row UW)	14.00 1094.27	14.00 1219.78	14.00 1561.92	14.00 1759.58	15.00 2220.94	15.00 2558.94	15.00 3094.04	15.00 3638.44
-Extended-medium horizontal (with 8-row UW)	19.00 1148.70	19.00 1279.06	19.00 1613.56	19.00 1813.06	19.00 2275.46	19.00 2615.73	19.00 3163.21	19.00 3712.02
-Medium-large horizontal (with 10-row W)	24.50 1955.08	24.50 2216.68	24.50 2754.49	24.50 3215.01	24.50 3876.05	24.50 4488.82	24.50 5499.42	24.50 6713.50
-Large horizontal or vertical (with 10-row W)	48.00 2131.70	48.00 2401.84	48.00 2985.19	48.00 3454.40	—	—	—	—
Electric Heat Coil	63.75 1666.00	63.75 1825.00	68.50 2267.00	48.00 2297.00	49.00 2857.00	—	—	—
Integral-face-and-bypass coil								
-Less than 4 rows	29.50 1129.66	29.50 1168.40	29.50 1793.80	29.50 1956.80	29.50 2322.61	29.50 2378.60	29.50 2865.77	29.50 2936.42
-4 rows	43.00 1677.52	43.00 1720.20	—	—	—	—	—	—
Controls section (with largest available VFD)	28.50 637.00	28.50 674.00	28.50 745.00	28.50 787.00	28.50 964.00	28.50 1031.00	28.50 1146.00	28.50 1266.00
Diffuser	24.50 319.05	24.50 342.74	24.50 381.33	24.50 397.35	27.50 571.76	37.25 715.78	37.25 781.92	37.25 860.66
Discharge plenum								
-Horizontal	48.00 627.24	48.00 677.47	48.00 772.27	48.00 821.10	49.00 1058.35	54.00 1198.64	60.00 1423.88	60.00 1585.80
-Vertical	63.75 876.48	63.75 949.58	68.50 1136.53	—	—	—	—	—
Energy Wheel	61.00 2403.00	65.00 2742.00	65.00 3111.00	—	—	—	—	—
Face-and-Bypass Dampers								
-Face-and-bypass	19.00 473.39	19.00 556.23	19.00 630.10	19.00 714.61	19.00 888.33	19.00 973.60	19.00 1093.88	19.00 1205.53
Filters								
-Side load 2-in. angled	24.50 593.86	24.50 649.06	27.50 770.02	27.50 797.89	27.50 989.00	27.50 1088.02	27.50 1157.16	27.50 1282.20
-Side load 4-in. angled	24.50 594.02	24.50 631.64	27.50 768.20	27.50 805.97	27.50 999.89	27.50 1105.14	27.50 1201.91	27.50 1338.65
-Side load cartridge 12-in. or short bag 18-in.	24.50 681.24	24.50 668.25	27.50 878.57	27.50 934.14	27.50 1239.99	27.50 1364.91	27.50 1746.31	27.50 1903.54
-Side load 2-in. flat	14.00 319.66	14.00 358.18	14.00 408.69	14.00 438.52	15.00 598.12	15.00 637.02	15.00 716.56	15.00 817.63
-Side load 4-in. flat	14.00 359.20	14.00 375.13	14.00 451.33	14.00 498.71	15.00 657.87	15.00 729.15	15.00 803.46	15.00 913.90
Filters								
-Side load 2-in. and 4-in. combination flat	19.00 476.00	19.00 504.37	19.00 600.40	19.00 671.64	19.00 853.08	19.00 981.02	19.00 1078.09	19.00 1165.92
-Side-load long bag 30-in.	37.25 657.41	37.25 716.04	37.25 826.72	37.25 906.56	37.25 1094.61	37.25 1270.51	37.25 1393.17	37.25 1549.80
-Front-load HEPA	40.00 985.62	40.00 1128.46	40.00 1397.21	40.00 1520.35	40.00 1845.81	40.00 2141.38	40.00 2553.97	40.00 2924.72



Dimensions and Weights

Table 7. Section dimensions (inches) and weights (pounds) — unit sizes 31 to 120 (continued)

Unit size	35	40	50	57	66	80	100	120
-Front-load cartridge	40.00 867.68	40.00 922.78	40.00 1093.06	40.00 1173.89	40.00 1449.48	40.00 1671.46	40.00 1923.09	40.00 2155.95
-Front-load short bag	45.00 750.89	45.00 799.75	45.00 917.08	45.00 979.84	45.00 1231.49	45.00 1365.35	45.00 1538.95	45.00 1696.33
Gas Heat — Drum and Tube								
- 200 MBh	—	—	—	—	—	—	—	—
- 300 MBh	—	—	—	—	—	—	—	—
- 320/360 MBh	66.00 1402.11	—	—	—	—	—	—	—
- 560 MBh	66.00 1594.61	64.00 1468.07	64.00 1853.53	64.00 1900.53	—	—	—	—
- 700 MBh	73.00 1895.19	75.00 1804.11	74.00 2190.52	74.00 2241.91	74.00 2490.63	—	—	—
- 860 MBh	80.00 2046.29	75.00 2098.72	74.00 2280.52	74.00 2331.91	74.00 2580.63	74.00 2198.81	—	—
- 1000 MBh	80.00 1723.73	81.00 1844.68	77.00 2325.57	77.00 2082.86	74.00 2300.63	74.00 1918.81	84.00 3156.04	92.00 3125.34
- 1250-1750 MBh	101.00 2540.84	105.00 2717.94	106.00 3264.84	106.00 2942.76	109.00 3309.39	109.00 2949.68	92.00 3878.54	102.00 3886.60
- 2000 MBh	—	—	3758.71	3430.29	3688.33	3320.33	4503.52	4391.21
-2400 MBh	—	—	—	—	118.00 3890.31	112.00 3455.33	121.00 4715.85	119.00 4668.51
Humidifier								
-Building steam	14.00 544.00	14.00 599.00	14.00 782.00	14.00 897.00	15.00 1123.00	15.00 1215.00	15.00 1363.00	15.00 1551.00
-Atmospheric seam	19.00 581.00	19.00 665.00	19.00 724.00	19.00 803.00	19.00 977.00	19.00 1078.00	19.00 1265.00	19.00 1492.00
Mixing box								
-with angled filters	48.00 519.12	48.00 561.92	48.00 653.36	48.00 653.36	49.00 946.02	54.00 1077.83	60.00 1287.99	60.00 1433.55
-with front/back Traq and top Traq dampers	63.75 966.49	63.75 1073.80	68.50 1261.78	68.50 1365.59	84.00 1907.28	92.00 2151.42	96.00 2473.12	96.00 2790.48
-reduced length with side/top/back/bottom airfoil damper	35.50 708.50	38.50 795.10	41.50 947.60	41.50 1022.70	41.50 1328.50	41.50 1453.60	47.00 1731.30	53.00 2025.40
Silencer								
-3 ft	38.00 918.00	38.00 974.00	38.00 1226.00	38.00 1332.00	38.00 1573.00	38.00 1741.00	38.00 2196.00	38.00 2555.00
-5 ft	62.00 1335.00	62.00 1439.00	62.00 1795.00	62.00 1945.00	62.00 2313.00	62.00 2555.00	62.00 3230.00	62.00 3786.00
UV light								
	14.00 325.48	14.00 352.71	14.00 394.34	14.00 419.43	15.00 574.52	15.00 604.11	15.00 667.60	15.00 758.72
Trane Commercial Air Purification System (TCAPS)								
	24.00 473.17	24.00 530.84	24.00 609.66	24.00 661.52	24.00 745.62	24.00 892.97	24.00 1019.10	24.00 1161.86
Pipe cabinet weight								
15 in. long, 36-in. deep	175.00	175.00	191.00	209.00	215.00	243.00	265.00	265.00
24 in. long, 36-in. deep	199.00	199.00	216.00	236.00	243.00	273.00	298.00	298.00
48 in. long, 36-in. deep	263.00	263.00	284.00	309.00	317.00	354.00	385.00	385.00
96 in. long, 36-in. deep	392.00	392.00	421.00	454.00	466.00	517.00	558.00	558.00

Notes:

1. Nominal airflow is based on 500 fpm through a nominal coil (i.e. 500xunit size 8=4000 cfm).
2. Airflow@625 fpm through the flat filter (maximum filter velocity).
3. Height includes standard 2.5-inch base frame for sizes 3 to 57 and 6-inch base frame for sizes 66 to 120.
4. Height includes 6-inch base frame for sizes 3 to 120.
5. Variable lengths available from 14 to 96-inches.
6. Nominal length and height shown for discharge plenums. Variable plenum height and length is available from 0.5 to 1.5 of nominal.
7. Fan section weights include the heaviest fan with the largest ODP motor available.
8. Access section required with humidifiers for dispersion distance.
9. Multizone weight does not include cooling coil on lower deck.

Fans/Motors

Note: Trane has a Precision Motor™ option for direct-drive plenum fans. This offering takes a general purpose motor and re-rates the motor for higher rated loads. This maximizes part-load motor efficiency and precisely sizes the motor for the application. To use these tables, the nameplate hp of the motor and the

VFD — both of which will be greater than the Precision Motor hp — must be known.

Starter/VFD Weights

With the exception of motorized impellers, fan weight does not include starter/VFD weight. See for approximate starter/VFD weight.

Table 8. Approximate starter and VFD weights per horsepower (lbs.)

Horsepower	1	1 1/2	2	3	5	7 1/2	10	15	20	25	30	40	50	60	75	100	125
VFD	123	123	132	124	125	136	151	162	177	197	241	325	332	243	258	294	314

Note: VFD weights include transformer, distribution block, and enclosure.

Motor Weights

Fan weights provided in this manual include the heaviest ODP (open drip-proof) motor. In the case of motorized impellers, fan weights include the packaged motor.

Table 9. Approximate motor weights (pounds)

Motor Type	Motor RPM	Horsepower															
		3/4	1	1-1/2	2	3	5	7-1/2	10	15	20	25	30	40			
Energy efficient ODP (EEOP)	1800	24	29														
NEMA Premium ODP (HEOP)	1200	39	77	91	147	126	249	300	375	443	594	667					
NEMA Premium TEFC (HETC)		56	96	109	148	185	310	341	423	481	614	655					
NEMA Premium ODP (HEOP)	1800	36	42	47	76	82	118	148	234	263	330	379	488				
NEMA Premium TEFC (HETC)		47	54	56	91	108	159	185	285	315	452	481	578				
NEMA Premium ODP (HEOP)	3600	36	36	37	89	104	173	203	267	243	261	407					
NEMA Premium TEFC (HETC)		36	53	62	85	103	154	176	287	322	448	496					



A2L Information and Installation Requirements

Installation/Code Compliance Requirements

Building level controls may need to be upgraded/modified to demand leak mitigation actions as described in “Leak Detection System

(R-454B charge greater than 3.91 lb per circuit or R-32 charge greater than 4.04 lb per circuit),” p. 28.

Those actions include, but are not limited to, fully opening damper and VAV boxes (if present), and disabling electric heat in VAV boxes (if present).

Verify the equipment refrigerant charge is in accordance with the room area limitation as described in Minimum Room Area Limits section.

Ensure that there are labels on the equipment stating it contains a flammable refrigerant.

A2L Work Procedures

⚠ WARNING

Risk of Fire — Flammable Refrigerant!

Failure to follow instructions below could result in death or serious injury, and equipment damage.

- To be repaired only by trained service personnel.
- Do not puncture refrigerant tubing.
- Dispose of properly in accordance with federal or local regulations.
- The equipment shall be stored in a room without continuously operating ignition sources.

⚠ WARNING

Refrigerant under High Pressure!

Failure to follow instructions below could result in an explosion which could result in death or serious injury or equipment damage.

System contains refrigerant under high pressure. Recover refrigerant to relieve pressure before opening the system. See unit nameplate for refrigerant type. Do not use non-approved refrigerants, refrigerant substitutes, or refrigerant additives.

⚠ WARNING

Hazardous Voltage!

Failure to disconnect power before servicing could result in death or serious injury.

Disconnect all electric power, including remote disconnects before servicing. Follow proper lockout/tagout procedures to ensure the power can not be inadvertently energized. Verify that no power is present with a voltmeter.

The units described in this manual use R-454B or R-32 refrigerant. Use ONLY R-454B or R-32 rated service equipment or components with these units. For specific handling concerns with R-454B or R-32, contact your local Trane representative.

Installation, repair, removal, or disposal should be performed by trained service personnel.

At all times, Trane’s maintenance and service guidelines shall be followed. If in doubt, contact Trane technical support for assistance.

Service

Prior to initiating work on equipment, check the area with an appropriate refrigerant detector. Ensure the service personnel are properly trained regarding work in potentially toxic or flammable atmospheres. Ensure that the leak detection equipment being used is suitable for use with all applicable refrigerants, i.e. non-sparking, adequately sealed, or intrinsically safe. Be aware that the refrigerant does not contain an odor.

If any hot work is to be conducted on the refrigerating equipment or any associated parts, appropriate fire extinguishing equipment shall be available on hand. A dry powder or CO₂ fire extinguisher should be located adjacent to the charging area.

At all times, Trane’s maintenance and service guidelines shall be followed. If in doubt, contact Trane technical support for assistance.

All maintenance staff and others working in the local area shall be instructed on the nature of the work being carried out. Work in confined spaces shall be avoided.

Ignition Source Mitigation

Do not use any sources of ignition when working on the refrigeration system.

Keep all ignition sources, including cigarette smoking, away from the site of installation, repair, removal or disposal, during which refrigerant can potentially be released to the surrounding space.

Survey the area around the equipment before initiating work to ensure no flammable hazards or ignition risks are present.

“No Smoking” signs shall be displayed.

Do not use devices that can be a source of ignition to accelerate defrosting of components. Use only defrost and cleaning procedures recommended by Trane. Do not pierce or burn.

Ventilation

Ensure that the area is in the open or that it is adequately ventilated before breaking into the system or conducting any hot work. A degree of ventilation shall continue during the period that the work is carried out. The ventilation should safely disperse any released refrigerant and preferably expel it externally into the atmosphere. If present, check that the ventilation system, including outlets, are operating adequately and are not obstructed.

Refrigerating Equipment

Refrigerant piping or components should not be installed in locations where substances which may corrode them are present.

Check that equipment hazard markings are visible and legible. Replace them if they are not.

For equipment using secondary fluids, like water or glycol, check that refrigerant is not present in the secondary fluid loop before conducting any hot work.

Electrical Devices

Do not apply power to the circuit if a fault exists which compromises safety. If the fault cannot be corrected immediately, but it is necessary to continue operation, an adequate temporary solution shall be used. This shall be reported to the owner of the equipment, so all parties are advised.

Initial safety checks shall include:

- Cabling is not subject to wear, corrosion, excessive pressure, vibration, sharp edges, or any other adverse environmental effects. Account for the effects of aging or continual vibration from sources such as compressors or fans.
- Capacitors are discharged. This shall be done in a safe manner to avoid possibility of sparking.
- No live electrical components and wiring are exposed while charging, recovering, or purging the system.
- Verify continuity of earth bonding.
- Replace electrical components with Trane replacement parts, or those meeting the same ratings and qualified for flame arrest protection, UL LZGH2 category.

Leak Detection

Never use an open flame to detect leaks. A halide torch should not be used. Use only approved leak detection methods per this instruction manual.

The following leak detection methods are deemed acceptable for all refrigerant systems.

Electronic leak detectors may be used to detect refrigerant leaks but, in the case of flammable refrigerants, the sensitivity may not be adequate, or may need re-

calibration. (Detection equipment shall be calibrated in a refrigerant-free area.) Verify the detector is not a potential source of ignition and is suitable for the refrigerant used. Leak detection equipment shall be set at a percentage of the LFL gas (25% maximum) is confirmed.

Leak detection fluids are also suitable for use with most refrigerants but the use of detergents containing chlorine shall be avoided as the chlorine may react with the refrigerant and corrode the copper pipe-work.

Examples of leak detection fluids are:

- Bubble method
- Fluorescent method agents

If a leak is suspected, all naked flames shall be removed/ extinguished.

If a refrigerant leak is found which requires brazing, all refrigerant shall be recovered from the system, or isolated (by means of shut-off valves) in a part of the system remote from the leak.

Refrigerant Removal and Evacuation

Ensure that the correct number of cylinders for holding the total system charge is available. All cylinders to be used are designated for the recovered refrigerant and labeled for that refrigerant (special cylinders for the recovery of refrigerant, for example). Cylinders shall be complete with pressure-relief valve and associated shut-off valves in good working order. Empty recovery cylinders are evacuated and, if possible, cooled before recovery occurs.

When breaking into the refrigerant circuit to make repairs – or for any other purpose – conventional procedures shall be used. However, for flammable refrigerants it is important that best practice be followed, since flammability is a consideration.

The following procedure shall be adhered to:

1. Safely remove refrigerant following local and national regulations.
2. Evacuate.
3. Purge the circuit with inert gas.
4. Evacuate (optional for A2L).
5. Continuously flush or purge with inert gas when using flame to open circuit.
6. Open the circuit.

Prior to refrigerant removal, open all appropriate valves, including solenoid and electronic expansion valves (EXVs). Use control settings, where available. When not available, manually open all electronically controlled valves using acceptable service procedures.

The recovery equipment shall be in good working order with instructions available. Equipment shall be suitable for the recovery of the flammable refrigerant. For specific handling concerns, contact the manufacturer. Ensure all hose connections are checked for tightness to avoid refrigerant leaks.



A2L Information and Installation Requirements

In addition, a set of calibrated weighing scales shall be available and in good working order.

The refrigerant shall be recovered into the correct recovery cylinders if venting is not allowed by local and national codes. Do not mix refrigerants in recovery unit and especially not in cylinders.

Refrigerant recovery unit should be purged with an inert gas after each use or before using with a different refrigerant Class – for example, A2L to A1.

If compressors or compressor oils are to be removed, ensure that they have been evacuated to an acceptable level to make certain that flammable refrigerant does not remain within the lubricant. The compressor body shall not be heated by an open flame or other ignition sources to accelerate this process. When oil is drained from a system, it shall be carried out safely.

The system shall be purged with oxygen-free nitrogen to render the appliance safe for flammable refrigerants. This process might need to be repeated several times. Compressed air or oxygen shall not be used for purging refrigerant systems.

The system shall be vented down to atmospheric pressure to enable work to take place.

The outlet for the vacuum pump shall not be close to any potential ignition sources, and ventilation shall be available.

Refrigerant Charging

In addition to conventional charging procedures, the following requirements shall be followed.

- Ensure that contamination of different refrigerants does not occur when using charging equipment.
- Hoses or lines shall be as short as possible to minimize the amount of refrigerant contained in them.
- Cylinders shall be kept in an appropriate position according to the instructions.
- Ensure that the refrigerating system is earthed prior to charging the system with refrigerant.
- Label the system when charging is complete (if not already).
- Extreme care shall be taken not to overfill the refrigerating system.

Prior to recharging the system, it shall be pressure-tested with the appropriate purging gas. The system shall be leak-tested on completion of charging but prior to commissioning. A follow up leak test shall be carried out prior to leaving the site.

Prior to refrigerant charging, open all appropriate valves, including solenoid and electronic expansion valves (EXVs). Use control settings, where available. When not available, manually open all electronically controlled valves using acceptable service procedures.

Verify the equipment refrigerant charge is in accordance with the room area limitation as described in Minimum Room Area Limits section.

Decommissioning

Before carrying out the decommissioning procedure, it is essential that the trained service personnel is completely familiar with the equipment and all its details. It is recommended good practice that all refrigerants are recovered safely. Prior to the task being carried out, an oil and refrigerant sample shall be taken in case analysis is required prior to re-use of recovered refrigerant. It is essential that electrical power is available before the task is commenced.

1. Become familiar with the equipment and its operation.
2. Isolate system electrically.
3. Before attempting the procedure, ensure that:
 - a. Mechanical handling equipment is available, if required, for handling refrigerant cylinders.
 - b. All personal protective equipment is available and being used correctly.
 - c. The recovery process is supervised at all times by a competent person.
 - d. Recovery equipment and cylinders conform to the appropriate standards.
4. Pump down refrigerant system, if possible.
5. If a vacuum is not possible, make a manifold so that refrigerant can be removed from various parts of the system.
6. Make sure that cylinder is situated on the scales before recovery takes place.
7. Start the recovery machine and operate in accordance with instructions.
8. Do not overfill cylinders (no more than 80% volume liquid charge).
9. Do not exceed the maximum working pressure of the cylinder, even temporarily.
10. When the cylinders have been filled correctly and the process completed, make sure that the cylinders and the equipment are removed from site promptly and all isolation valves on the equipment are closed off.
11. Recovered refrigerant shall not be charged into another refrigerating system unless it has been cleaned and checked.
12. When equipment has been decommissioned, attach a signed and dated label stating it has been decommissioned and emptied of refrigerant.
13. Ensure that there are labels on the equipment stating it contains flammable refrigerant.

A2L Application Considerations

This product is listed to UL standard 60335-2-40, Household and Similar Electrical Appliances – Safety – Part 2-40: Particular Requirements for Electrical Heat Pumps, Air-Conditioners and Dehumidifiers, which defines safe design and use strategies for equipment using A2L

refrigerants. This standard limits the refrigerant concentration in a space in the event of a refrigerant leak. To meet the requirements, the UL standard defines minimum room area, refrigerant charge limit, minimum circulation airflow and/or ventilation airflow requirements, and limits the use of ignition sources in spaces. The standard may require a unit refrigerant leak detection system.

For equipment with either:

- R-454B and charge amounts less than or equal to 3.91 lbs per circuit
- R-32 and charge amounts less than or equal to 4.04 lbs per circuit

this UL standard does not prescribe a room area limit and does not require a refrigerant leak detection system or any circulation airflow or ventilation airflow mitigation strategies. However, ignition sources in ductwork must be evaluated.

Depending on the application, a specific requirement of ANSI/ASHRAE Standard 15, Safety Standard for Refrigeration Systems, could be more stringent than UL 60335-2-40 requirements. See *Refrigeration Systems and Machinery Rooms Application Considerations for Compliance with ASHRAE® Standard 15-2022 Application Engineering Manual* (APP-APM001*-EN) for more information.

Ignition Sources in Ductwork

Do not install open flames in the ductwork. Hot surfaces exceeding 700°C (1290°F) should not be installed in the ductwork unless the average airflow velocity is not less than 1.0 m/s (200 ft/min) across the heater and proof of airflow is verified before system is energized.

Electric heaters can exceed the surface temperature limit if airflow distribution is poor, or insufficient airflow is provided over the heater.

Surface temperatures of most gas heaters do not exceed the surface temperature limits due to ANSI construction requirements.

Ignition Sources in Unit

This unit does not contain any ignition sources. All potential ignition sources, (including factory or field installed accessory electric heaters, gas heaters, relays, and contactors) were evaluated during product UL listing.

Minimum Room Area Limits (R-454B charge greater than 3.91 lb per circuit or R-32 charge greater than 4.04 lb per circuit)

Equipment with charge amounts greater than values in the table below may require additional circulation or ventilation airflow mitigation strategies.

Table 10. Refrigerant charge for additional mitigation strategies

Refrigerant	Change (lb per circuit)
R-454B	3.91
R-32	4.04

In this case, there are two minimum room area (A_{min}) thresholds.

- The first threshold defines when equipment serving a single room is required to provide circulation airflow, either continuous or activated by a leak detection system. A ducted system requires circulation airflow unless the smallest room it serves is larger than the adjusted A_{min} threshold. This product contains a leak detection system if a circuit charge is greater than values shown in [Table 10, p. 25](#). As a result, no further leak detection system evaluation is needed.
- The second threshold defines when additional ventilation airflow is required. If the room area, A or TA , is below the adjusted A_{min} or TA_{min} threshold, additional ventilation is required to remove refrigerant in the event of a leak. Refer to UL 60335-2-40 Clause GG.8 and ANSI/ASHRAE Standard 15 Section 7 for natural and mechanical ventilation requirements. See equipment nameplate and table below for minimum room area.

Split systems minimum room area requirements need to be determined after final field charging. Use the following figures and the largest final circuit charge to determine the systems A_{min} value. Record the final charge value on the label provided on the condensing unit.

Figure 4. R-454B charge vs min room area (IP)

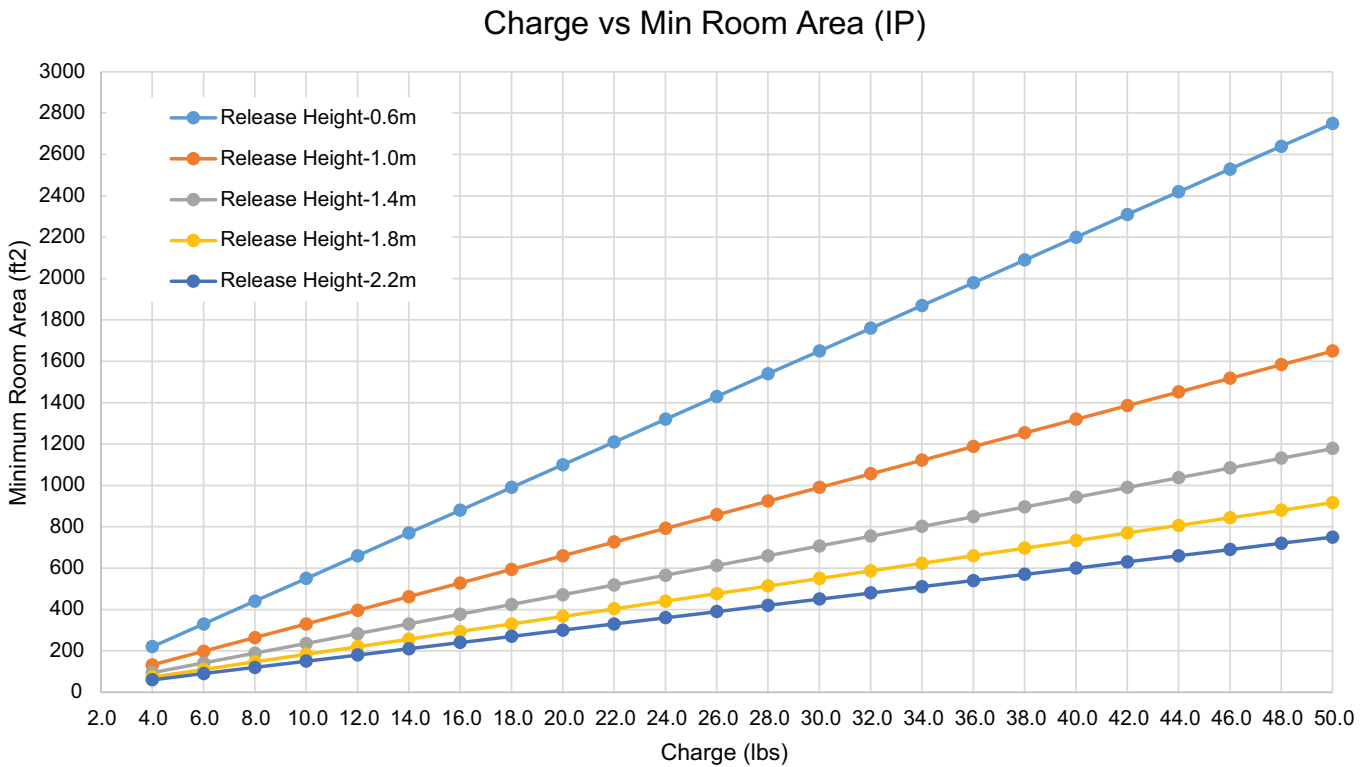

Figure 5. R-454B charge vs min room area (SI)

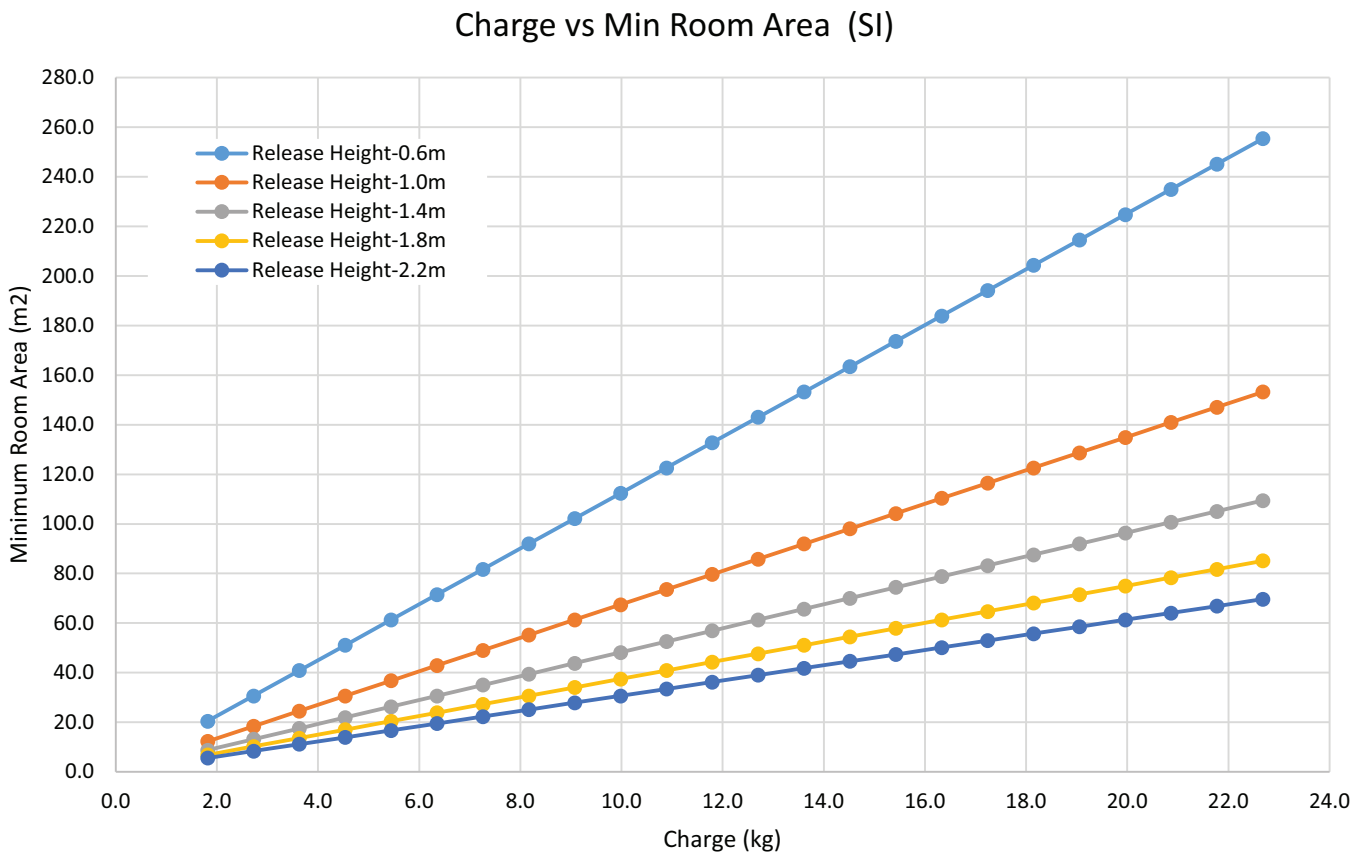

Figure 6. R-32 charge vs min room area (IP)

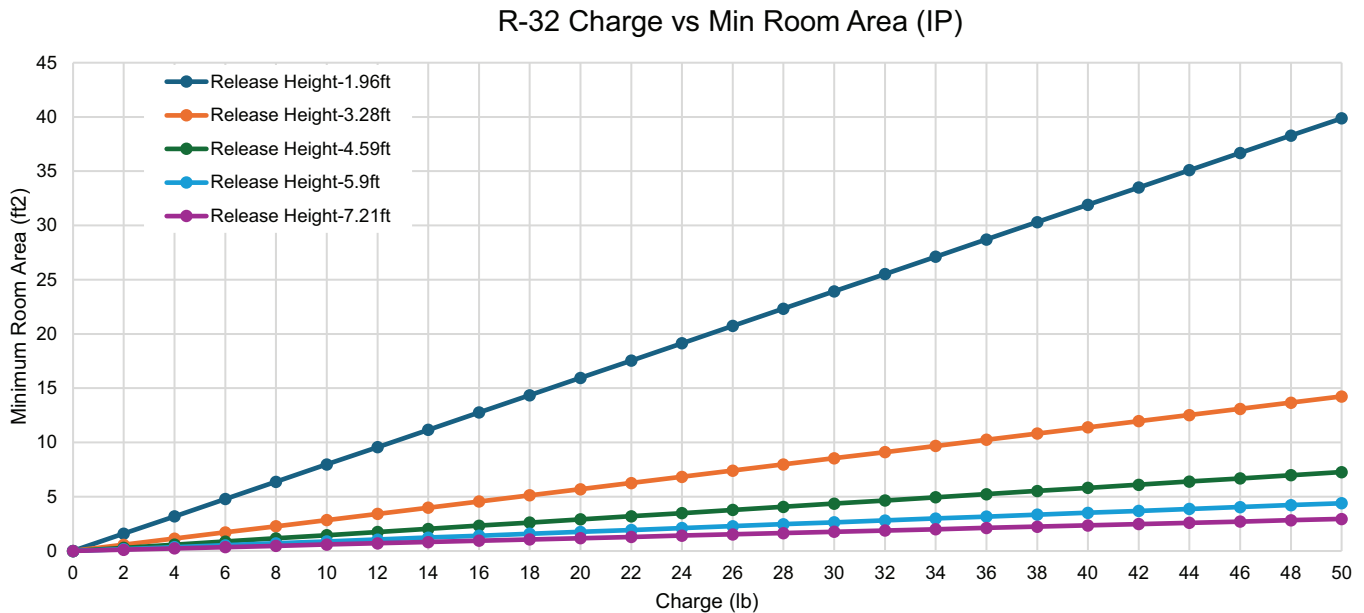
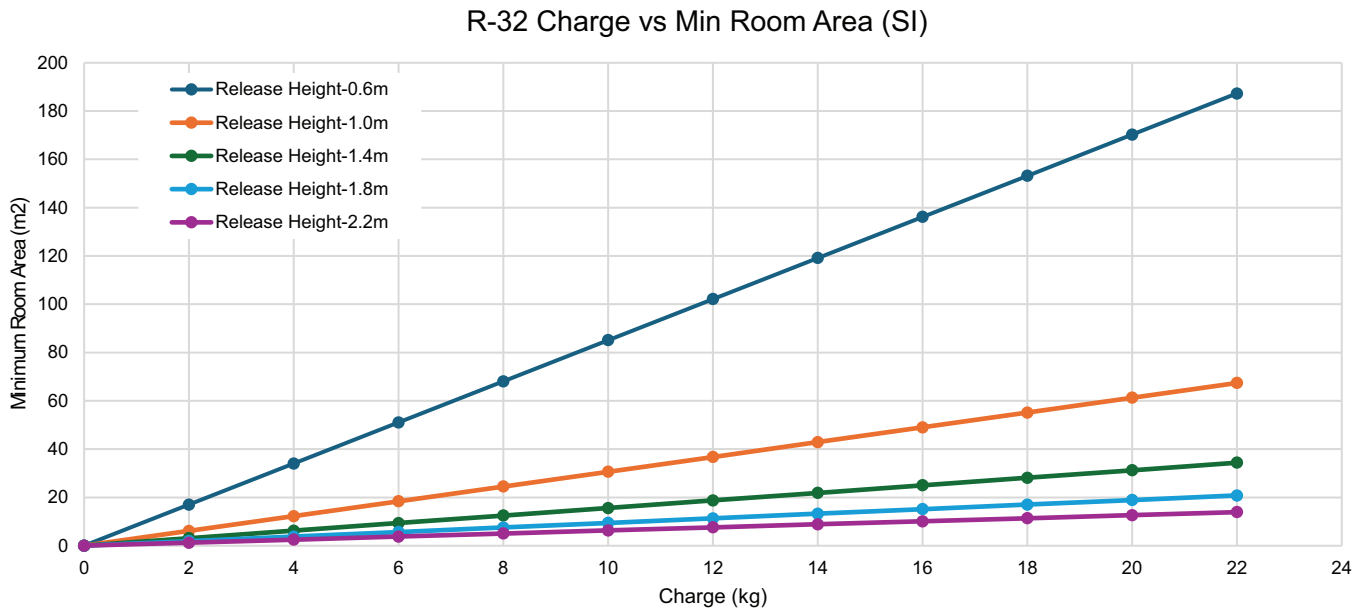

Figure 7. R-32 charge vs min room area (SI)



Release height is the vertical distance from the floor to the lowest point in a space refrigerant would leak from first. The minimum value is 0.6 m from the floor. This point is typically the bottom of free return openings or supply diffusers. For fully ducted units, the release height is 2.2 meters.

$$A_{min.adj} = \text{Nameplate } A_{min} \times \text{Altitude Adj} \times \text{Height Adj} \times F_{occ}$$

Multiply the altitude adjustment factor in the table below by A_{min} listed on the unit nameplate or in the Installation, Operation, and Maintenance (IOM) manual.

Minimum Room Area (A_{min}) Adjustments

Use equation below to adjust the minimum room area, as applicable, based on the unit's installation height, altitude, and occupancy level it serves.



A2L Information and Installation Requirements

Table 11. Altitude adjustment factor

Altitude (ft)	Sea Level to 2000	2001 to 4000	4001 to 6000	6001 to 8000	8001 to 10000	10001 to 12000	12001 to 14000	14001 to 15000	Over 15000
A_{min} Adjustment	1	1.05	1.11	1.17	1.24	1.32	1.41	1.51	1.57

In addition, A_{min} can be adjusted if the unit is installed in a room at a height that is higher than the minimum height shown on the unit. To adjust A_{min} , multiply by the ratio of the unit minimum release height (in meters) / actual release height (in meters). Use 0.6 m in the ratio for unit minimum installation heights less than or equal to 0.6 m.

For institutional occupancies, ASHRAE Standard 15 applies an additional adjustment factor F_{occ} to the amount of a charge allowed in a space. To calculate the adjusted A_{min} for institutional occupancies, multiply the A_{min} on the nameplate by two.

EXAMPLE 1: 20 Ton Packaged Rooftop Multi-Zone VAV System Serving an Institutional Occupancy Space

The packaged unit serves 7600 ft.² of a nursing home located at an altitude of 4000 ft. The unit has two equally charged 10 ton refrigeration circuits. Each circuit has 12 lbs of refrigerant with a minimum room area requirement of 180 ft.² with a 2.2 m release height.

$$TA_{min.adj} = 180 \text{ ft.}^2 \times 1.05 \times 2 = 378 \text{ ft.}^2$$

No additional ventilation is required.

EXAMPLE 2: 10 Ton Split System Serving a Single Commercial Occupancy Space

The split system serves a 1500 ft.² manufacturing space at 5000 ft. altitude. The final installed charge of the single circuit 10 ton unit is 20 lb. The unit has an open return with a release height of 1 m and ducted supply air. The unit A_{min} is 660 ft.².

$$A_{min.adj} = 660 \text{ ft.}^2 \times 1.11 = 733 \text{ ft.}^2$$

No additional ventilation is required.

Determining Room Area (A or TA)

The room area (A) is the room area enclosed by the projection to the floor of the walls, partitions, and doors of the space that the equipment serves. For ducted systems, total room area (TA) of all rooms connected by ducts, may be used instead of A.

Rooms connected by drop ceilings only are not considered a single room.

Rooms on the same floor of the building, and connected by an open passageway, can be considered part of the same room if the passageway is a permanent opening, extends to the floor and is intended for people to walk through.

Adjacent rooms on the same floor of the building and connected by permanent openings in the walls and/or doors between rooms (including gaps between the wall and

the floor), can be considered part of the same room if the openings meet the following criteria.

- The opening is permanent and cannot be closed.
- Openings extending to the floor, such as door gaps, need to be at least 20 mm above the floor covering surface.
- Natural ventilations opening areas must meet the requirements of ANSIASHRAE Standard 15-2022, Section 7.2.3.2.

Rooms that are connected by a mechanical ventilation system can be considered a single room area if the mechanical ventilation system meets the requirements of ANSIASHRAE Standard 15-2022, Section 7.6.4.

Leak Detection System (R-454B charge greater than 3.91 lb per circuit or R-32 charge greater than 4.04 lb per circuit)

The leak detection system consists of one or more refrigerant detection sensors. When the system detects a leak, the following mitigation actions will be initiated until refrigerant has not been detected for at least 5 minutes:

- Energize the supply fan(s) to deliver a required minimum amount of circulation airflow.
- Disable compressor operation.
- Provide an output signal that can be used to fully open zone dampers and/or VAV boxes and disable electric heat in VAV boxes.
- Provide an output signal that can be used to energize additional mechanical ventilation (if needed).
- Units without airflow proving will disable electric heat sources.

Building fire and smoke systems may override this function.

If the refrigerant sensor has a fault, is at the end of its life, or is disconnected, the unit will initiate the mitigation actions. Mitigation actions may be verified by disconnecting the sensor.

The refrigerant sensors do not need service. Use only manufacturer-approved sensors when replacement is required.

Field Piping Installation and Charging

When refrigerant piping is routed indoors, protect from physical damage in operation or service, and verify installation complies with national and local codes. All joints must be accessible for inspection prior to being covered.

Follow the Refrigerant Charging procedure. Prior to refrigerant charging, check field-made indoor joints for leaks using an instrument with a sensitivity of 5 grams per year refrigerant. Pressurize the system to 25% of the maximum allowable pressure. Verify no leaks are detected.

Installation — Mechanical

Important: Verify installation location meets requirements shown in “Installation Clearances (Electric Heat),” p. 12.

Lifting and Rigging

Remove Shipping Tie Downs

Prior to unit placement, remove the shipping tie-downs.

Figure 8. Remove shipping tie-downs

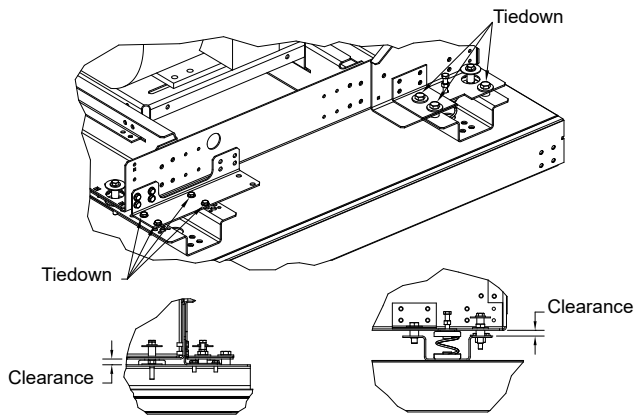

Figure 9. Shipping tie-down - rear view

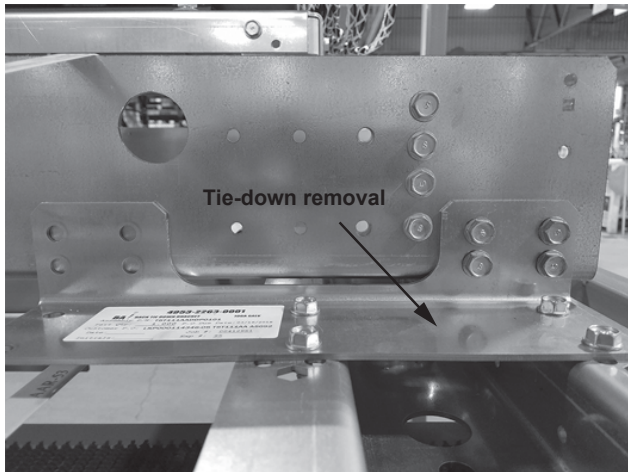
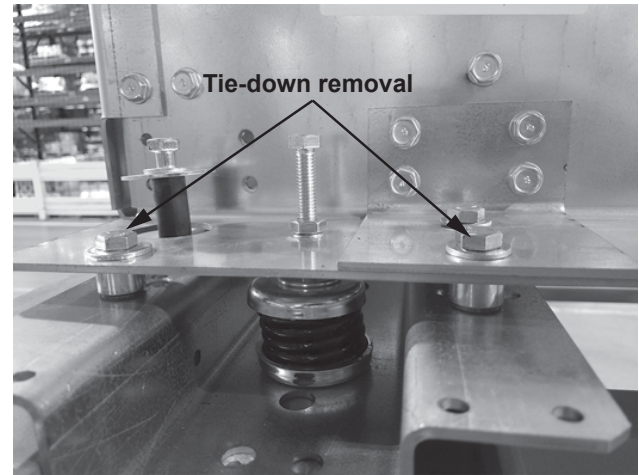

Figure 10. Shipping tie-down - front view



- Shipping tie-downs are located at each corner of the isolation base.

Figure 11. Isolator tie-down for unit sizes 3-8

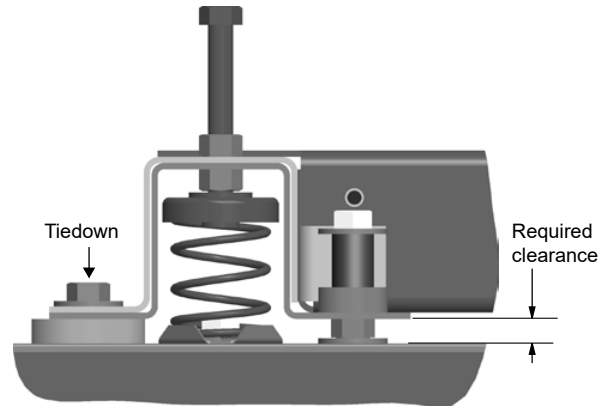

Figure 12. Isolator tie-down for unit sizes 10-30

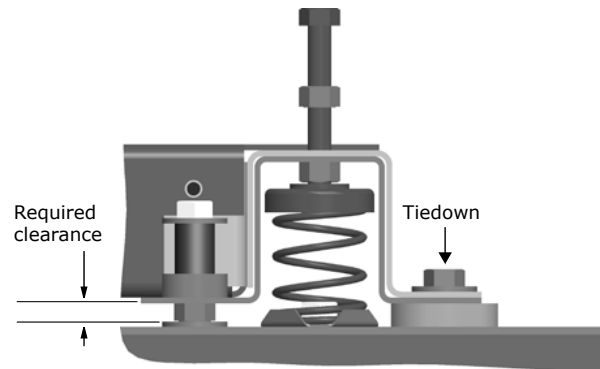

Figure 13. Isolator tie-down removal for unit sizes 66-120

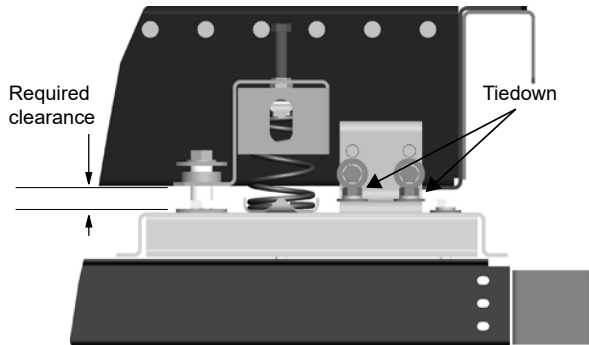
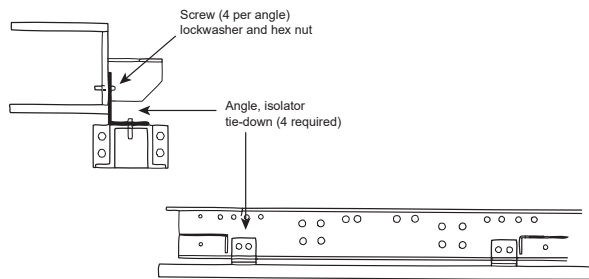
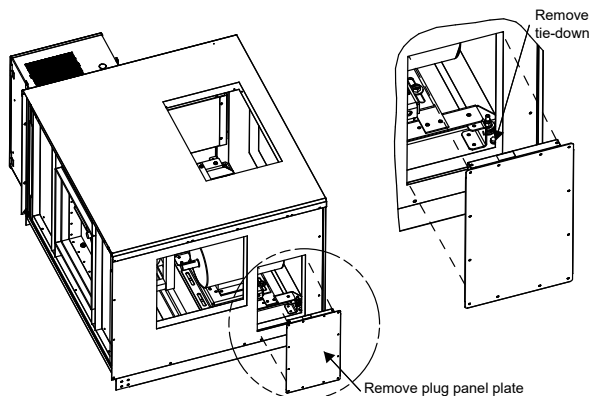

Figure 14. Isolator tie-down removal for unit sizes 35 - 120



- Access for removal of shipping tie-downs for unit sizes 3 to 30 is available through the fan section access door or opposite drive-side plug panel. See [Figure 15, p. 31](#).

Figure 15. Plug panel plate



- Access for removal of shipping tie-downs for unit sizes 3-30 is available through the fan section access door or opposite drive-side plug panel. See [Figure 15, p. 31](#).
- Remove the bolt. This will release the isolator and make it possible to remove the pipe or spacer.
- Replace plug panel if applicable.

Note: For outdoor air handlers, after isolator tie-down is removed, remove the paper backing from the butyl tape around plug panel perimeter prior to replacing plug panel.

DDP Fan Thrust Bumper

Confirm bumpers are not attached to the fan panel. The bumpers should be 1/2-inch from the panel to allow fan to free float on the spring isolators.

Figure 16. DDP fan thrust bumper

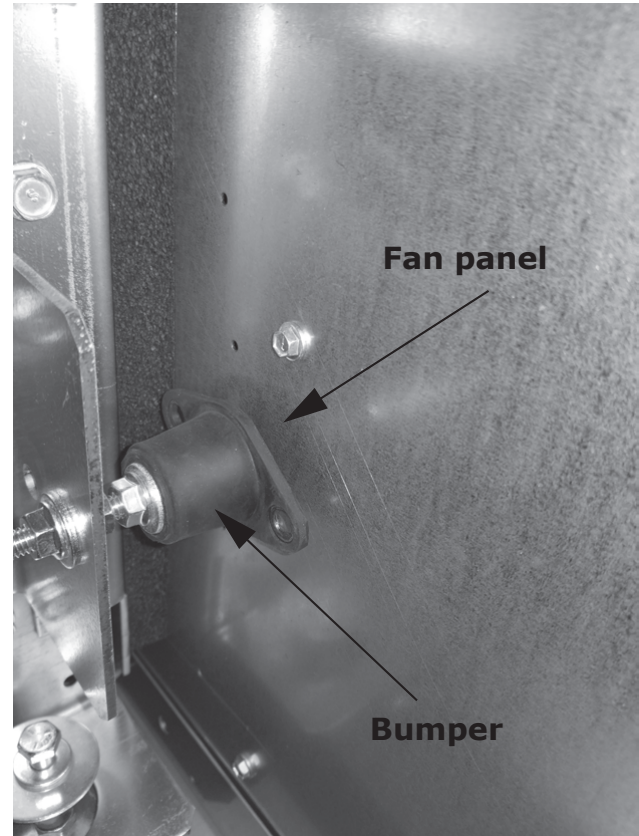

General Lifting Considerations

⚠ WARNING

Heavy Objects!

Placing, assembling, and/or suspending more than one module/subassembly at a time could result in death, serious injury, or equipment damage. Always place, assemble, and suspend modules/subassemblies one at a time.

⚠ WARNING

Improper Unit Lift!

Failure to properly lift unit in a LEVEL position could result in unit dropping and possibly crushing operator/technician which could result in death or serious injury, and equipment or property-only damage. Test lift unit approximately 24 inches (61 cm) to verify proper center of gravity lift point. To avoid dropping of unit, reposition lifting point if unit is not level.

NOTICE

Equipment Damage!

Premature skid removal could result in equipment damage. Keep skid in place until unit is ready to set. Do not move the unit or subassembly without the skid in place as shipped from the factory.

Before preparing the unit for lifting, estimate the approximate center of gravity for lifting safety. Because of placement of internal components, the unit weight may be unevenly distributed, with more weight in the coil and fan areas. Approximate unit weights are provided in “Dimensions and Weights,” p. 12. See the unit submittals for actual section weights. Test the unit for proper balance before lifting.

For outdoor air handlers, preparation of the roof curb or pier mount and roof openings must be completed before lifting to the roof. See *Roof Curbs for Performance Climate Changer Air Handlers installation instructions* (CLCH-SVN04*-EN) for details.

⚠ WARNING

Heavy Object!

Failure to follow instructions below could result in unit dropping which could result in death or serious injury, and equipment or property-only damage. Ensure that all the lifting equipment used is properly rated for the weight of the unit being lifted. Each of the cables (chains or slings), hooks, and shackles used to lift the unit must be capable of supporting the entire weight of the unit. Lifting cables (chains or slings) may not be of the same length. Adjust as necessary for even unit lift.

Always rig sub-assemblies or sections as they ship from the factory. Never bolt sections together before rigging. To assist in proper placement, organize all ship splits in order of configuration before hoisting units in place. See “Split to Split Orientation Instructions,” p. 33.

- Make the loop of the sling parallel to the direction of airflow, if possible.
- When hoisting the unit into position, use the proper rigging method, such as straps, slings, spreader bars, or lifting lugs for protection and safety.
- Use all lifting lugs provided. See Figure 17, p. 32, Figure 18, p. 32, and for lug hole sizes and location.

Figure 17. Lifting lugs for low-capacity and high-capacity units

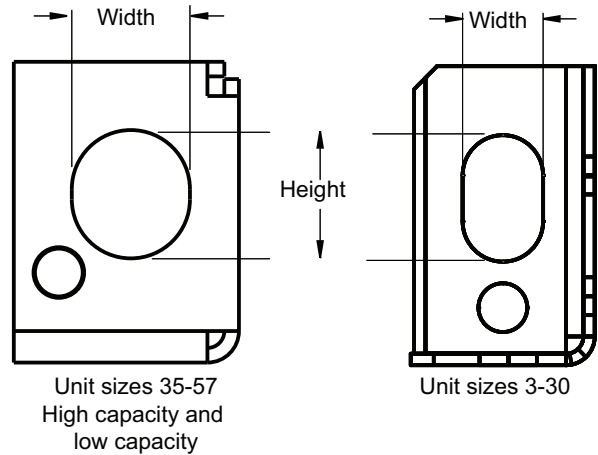

Figure 18. Lifting lug for pipe cabinets and hoods

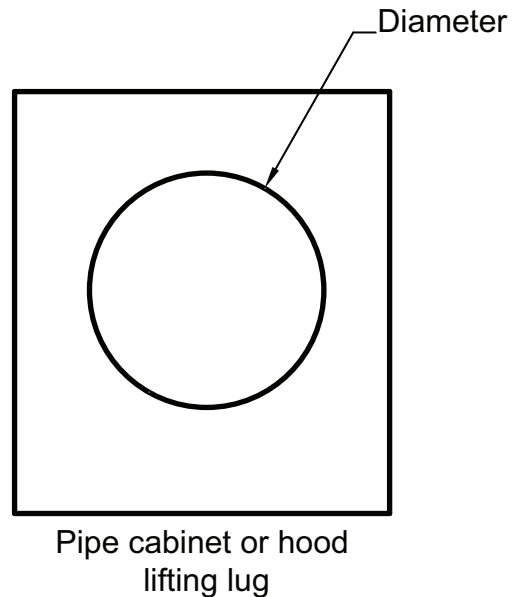

Figure 19. Lifting lug part numbers

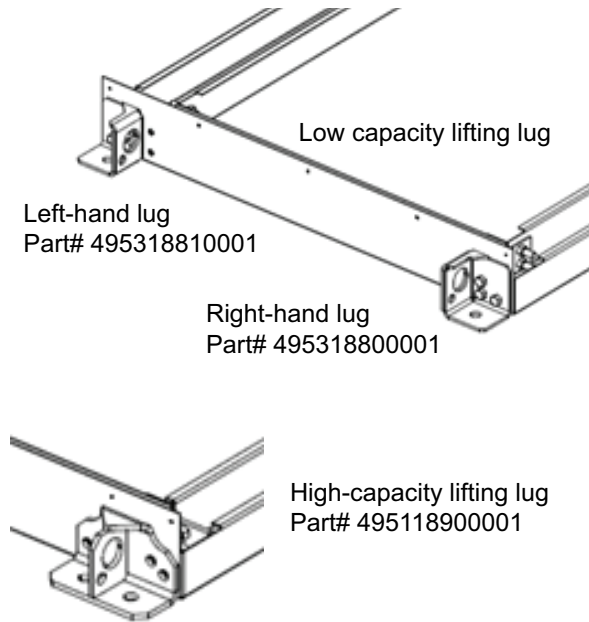

Figure 20. Lifting detail for unit sizes 3 to 120

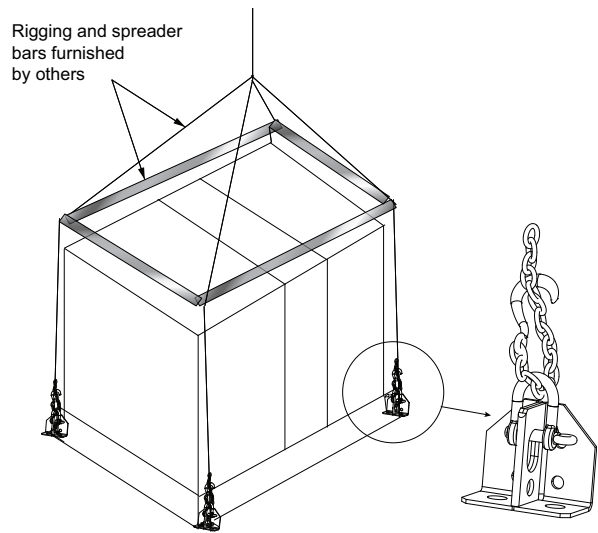

Table 12. Lug hole dimensions for low-capacity (under 3000 lbs.) and high-capacity (3000 lbs and over) units

Section	Location	Unit Size	Width	Height
Unit Lug Hole Size	Indoor	3-30	0.88	1.38
	Indoor	35-57	1.31	1.43
	Indoor	66-120	1.25	2.75
	Outdoor	3-30	1.25	2.75
Pipe Cabinet	Outdoor	3-120	2.5-in. diameter	
Hood	Outdoor	3-120	1-in. diameter	

- For outdoor units, never stack the pipe cabinet or inlet hood on the unit as it is being lifted.
- Do not attach the intake/exhaust hood or pipe cabinet to the unit prior to lifting the unit. Doing so may damage the equipment. Attach the hoods to the unit only after all sections are in place.

For outdoor air handlers, all shipping supports and crating on the face of the sections must be removed to permit proper fit-up and sealing of the surfaces. Dispose of properly.

Split to Split Orientation Instructions

Units with Split Indicators on Side Baseraills

Verify each sections indicators are on the split side baseraills and are aligned with each other. The indicators must have the same orientation and screw quantities. Example: In the following figure, the split on the left has two screws vertically orientated, while the split on the right has a single screw on each section.

- For unit sizes 3 to 120 with integral base frame, use field-provided spreader bars and slings to rig units and sub-assemblies as shown in Figure 20, p. 33. The air handler is not designed to be lifted or rigged from the top of the unit.

Units with Split Indicators on Perpendicular Baserails

Verify each sections indicators are on the split perpendicular baserails and have the same orientation and screw quantities. Example: In the following figure, split A and B has three screws at a 45 degree angle. Split B and C has two horizontally orientated screws on each section.

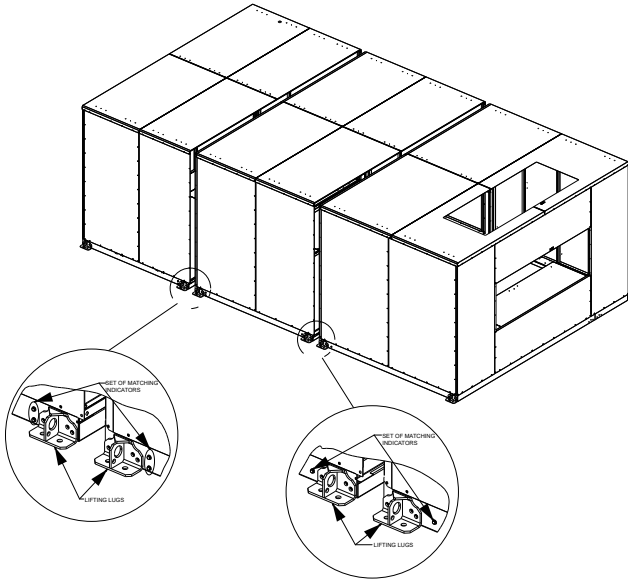
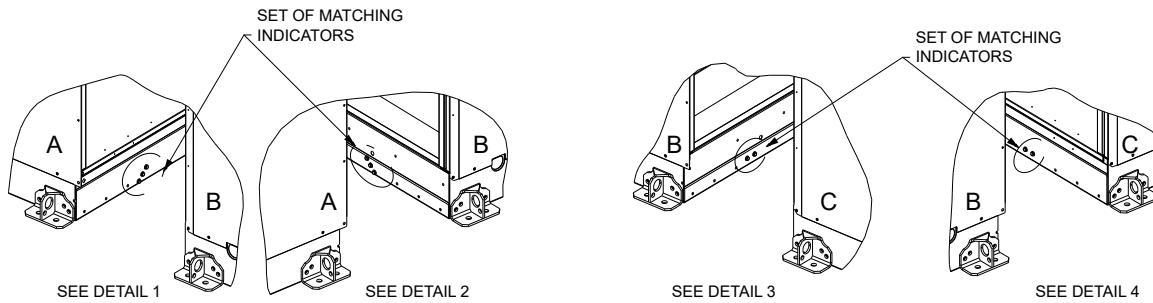
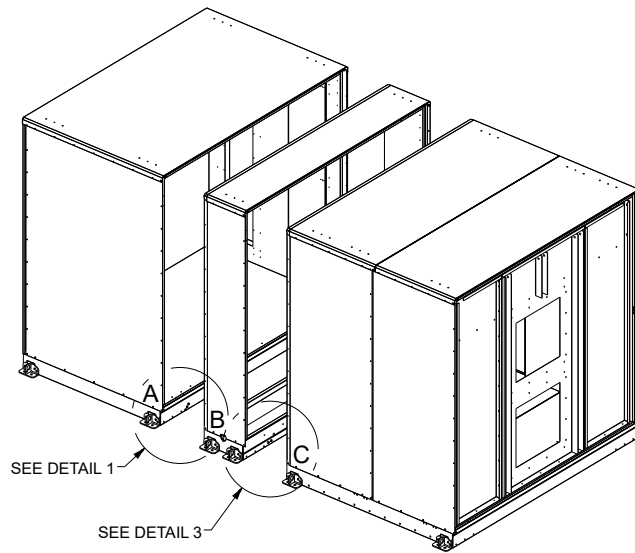

Figure 21. Units with split indicators on perpendicular baserails



Note: If no side or perpendicular baserail indicators are present, use submittal layout and the nameplate to orient the split units. The process may require a detailed review of the submittal package regarding split unit numbering and orientation.

Lifting Hoods and Pipe Cabinets

⚠ WARNING

Heavy Objects!

Placing, assembling, and/or suspending more than one module/subassembly at a time could result in death, serious injury, or equipment damage. Always place, assemble, and suspend modules/subassemblies one at a time.

Figure 22. Lifting inlet hurricane and exhaust hoods

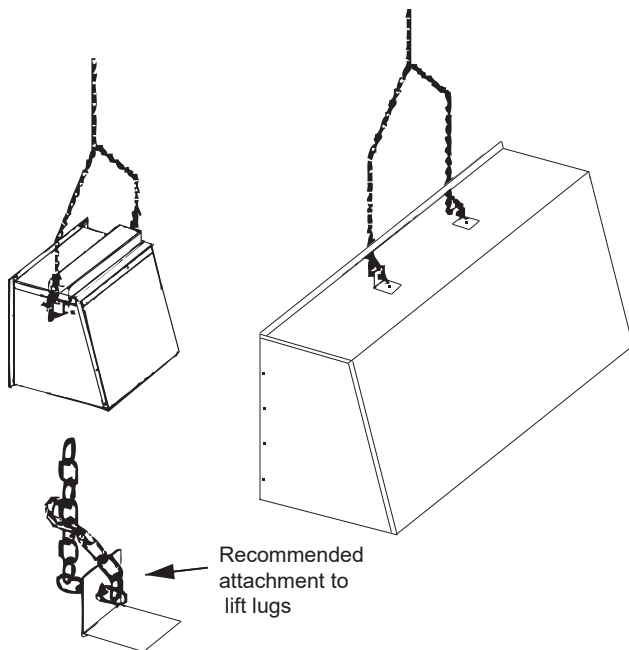
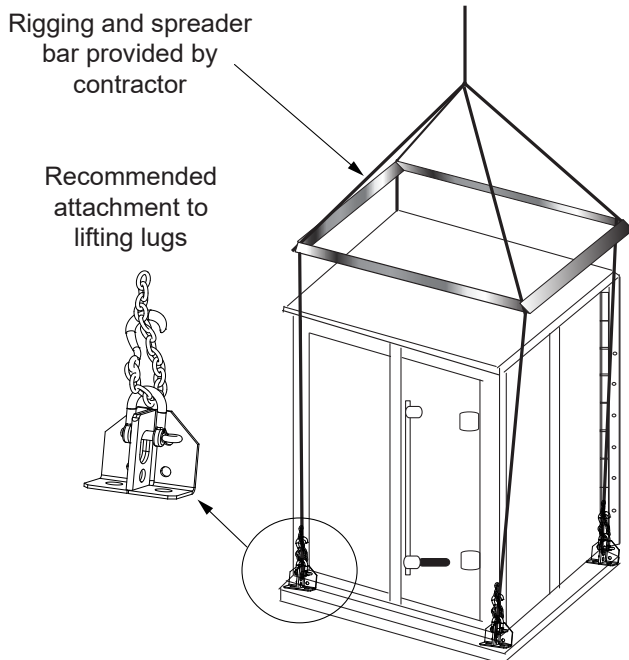

Figure 23. Lifting pipe cabinets



Forklifting Considerations

NOTICE

Equipment Damage!

Improper use of fork lift could result in equipment damage.

Do not use a fork lift on air handlers or subassemblies that do not have an end cleat. Trane is not responsible for equipment damage resulting from improper fork lift practices.

Note: Do not use a forklift on outdoor air handlers or indoor air handlers/subassemblies larger than size 30.

For unit sizes 3 to 30, a forklift may be used to lift a single section or small subassembly, provided the forks extend under both ends of the base frame, or as indicated in [Figure 24, p. 35](#). The forks should not contact the bottom of the air handler. Units should only be lifted from the proper end identified by the lifting label on the unit. A lifting crane or other means should be used for larger units where forks cannot extend under both base rails.

Figure 24. Forklift points with base rail

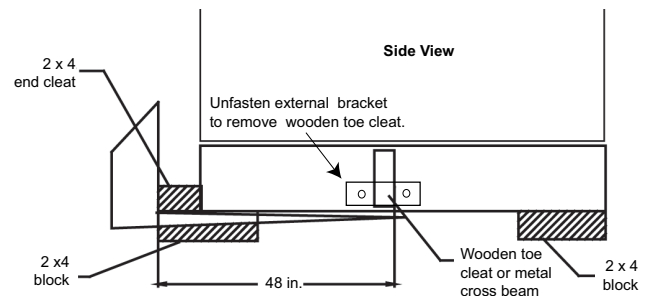

Unit Placement and Assembly

If the air handler ships in subassemblies or in individual sections, some assembly is required, including:

- Ceiling-suspended indoor unit assembly; see [“Ceiling Suspension,” p. 37](#).
- Section-to-section assembly; see [“Section-to-Section Assembly,” p. 38](#).

⚠ WARNING

Toxic Fumes!

Failure to follow instructions below could produce toxic gas which could result in death or serious injury. Keep open flame away from unit exterior or interior. Do not weld or use cutting torch on the exterior or interior. The unit contains polyurethane insulation. Flames could produce toxic gas.

NOTICE

Equipment Damage!

Failure to follow instructions below could result in equipment damage.

Do not exceed the following operating temperature limits in internal unit sections:

- Sections with electrical components: 104°F
- Sections without electrical components: 200°F

⚠ WARNING

Heavy Objects!

Placing, assembling, and/or suspending more than one module/subassembly at a time could result in death, serious injury, or equipment damage.

Always place, assemble, and suspend modules/subassemblies one at a time.

NOTICE

Microbial Growth!

Failure to follow instructions below could result in odors and damage to the equipment and building materials.

The floor or foundation must be level and the condensate drain at the proper height for proper drainage and condensate flow. Standing water and wet surfaces inside the equipment can become an amplification site for microbial growth (mold). If there is evidence of microbial growth on the interior insulation, it should be removed and replaced prior to operating the system.

If a unit arrives in sections, then each section must be individually hoisted, set on the housekeeping pad, roof curb, or pier mount and then assembled.

See the unit submittals and unit tagging for correct placement of all sections. If there are any discrepancies between the submittals and the unit tagging, contact your local Trane representative before proceeding.

Following the order of the sections on the unit submittals and tagging, individually place each unassembled section or subassembly in the appropriate installation location.

Note: Prior to placing fan section in the appropriate installation location, verify shipping tie-downs have been removed.

For outdoor units, the pipe cabinet must also be mounted as an individual section. See the “[Pipe Cabinet Installation](#),” p. 46 for specific instructions.

When mounting the unit on a roof curb, make sure the gasketing between the roof curb and unit base provides an airtight seal.

When mounting the unit on a pier mount, locate one pier at each corner as a minimum, directly underneath any shipping split (ensure full support under each side) and then every four feet at equally spaced intervals around the perimeter of the unit. Both the unit and the pipe cabinet

should be supported by their base around the entire perimeter. See [Figure 25](#), p. 36 and [Figure 26](#), p. 36.

Figure 25. Piers located in each corner and spaced evenly every four feet

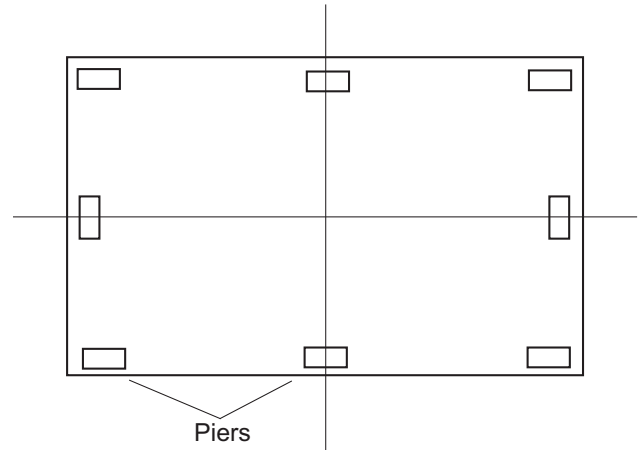

Note: Piers beneath shipping splits must be structurally sound to support the weight of the unit.

Figure 26. Side view with two shipping splits - locate one pier directly under each shipping split

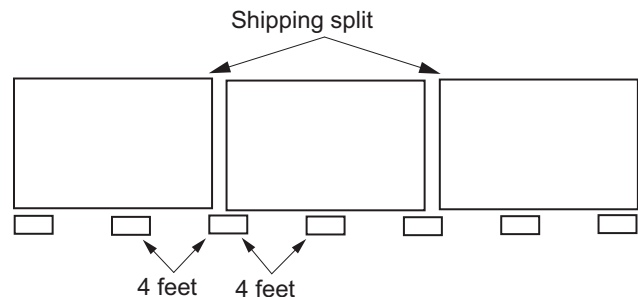

Note: Piers beneath shipping splits must be structurally sound to support the weight of the unit.

For proper operation, the unit must be installed level (zero tolerance) in both horizontal axes. For vertical discharge units, allow space under the unit for supply air ductwork connections.

Note: Air handlers often include optional factory-provided casing penetration entry points for field-provided wiring. Consider overall unit serviceability and accessibility before mounting, running wires (power), making cabinet penetrations, or mounting any components to the cabinet.

See “[Component Installation](#),” p. 72 for special assembly/installation considerations.

Removing the Shipping Skid

Remove the wooden shipping blocks, wooden toe cleat if there is one, and end cleats prior to lowering unit into final position or installing the unit to the roof curb.

Ceiling Suspension

⚠ WARNING

Risk of Unit Dropping!

Failure to follow instructions below could result in death or serious injury, and equipment damage. Inspect the suspension and/or support system to ensure all fasteners are tight and the unit is secure before working underneath the unit.

Note: Ceiling suspension is not recommended for units larger than size 57 unless using a field-provided mounting frame.

Using a Field-Provided Mounting Frame

If a field-provided mounting frame is used for ceiling suspension, the installer/contractor must provide a ceiling-suspended mounting frame designed to support the length, width, and weight of the entire air-handling unit. See “Dimensions and Weights,” p. 12 for approximate weights.

Note: It is the building engineer’s responsibility to size the structural channels and to provide the appropriate hangers.

Structural channels in a field-provided frame can be mounted parallel to airflow or perpendicular to airflow:

- For parallel-to-airflow channels, size channels based on a four-point load distribution (see Figure 27, p. 37).

Figure 27. Typical suspension method-parallel channels

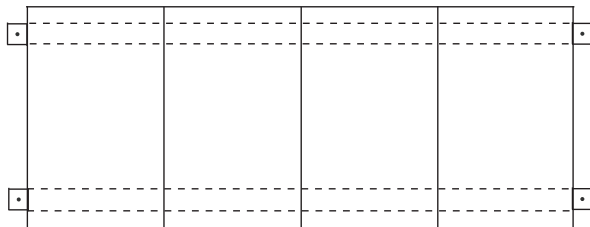

- For perpendicular-to-airflow channels, size channels based on the load distribution of the individual sections and install the channels so that both ends of every section are supported (see Figure 28, p. 37).

Figure 28. Typical ceiling suspension-perpendicular channels

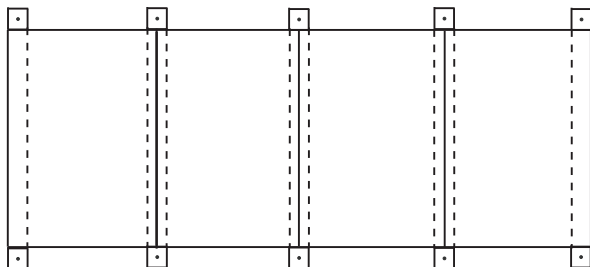

Using Integral Base Frame

Figure 29. Ceiling suspension for unit sizes for up to 28,000 cfm

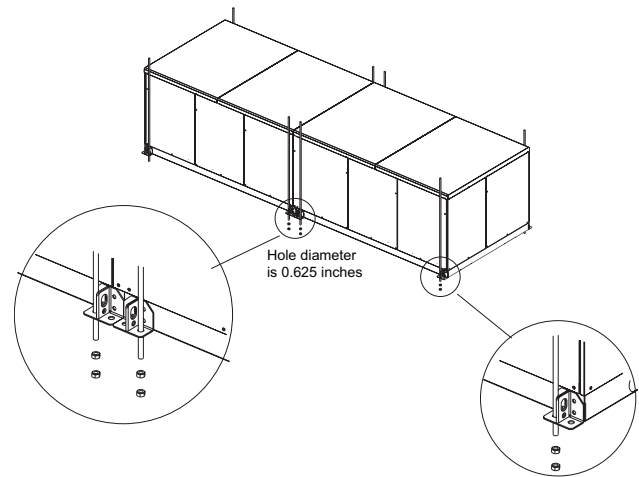

If using the factory-provided integral base frame for ceiling suspension, individual sections and/or subassemblies will have base frame shipping splits and base frame lifting lugs. When using the base frame for ceiling suspension:

- Suspend the unit (on both sides of the unit) at each shipping split lug as well as the four corners of the unit (see Figure 29, p. 37). See Figure 17, p. 32, Figure 18, p. 32, and Table 12, p. 33 for lug hole sizes.
- Bolt shipping splits together.

The hanger rods must extend through the bottom of the base lug. It is the building engineer’s responsibility to provide the appropriate hangers.

Shipping Gussets

Prior to pulling the shipping splits together, the shipping gussets (see Figure 30, p. 38) should be removed to simplify panel removal (except for hurricane units or units that require OSHPD certification). If there is enough access after joining the shipping splits, the gussets can be removed after they are joined. The exception to this rule is for size 35-50 stacked units. For these sizes, the gussets should be left in place for the lower level unit unless they are installed in a shipping split that contains a coil. The other exception is when access to install or change out front-loaded filters is restricted or blocked.

Figure 30. Shipping gusset



Do not mistake the coil structural gusset (see Figure 31, p. 38) used on unit sizes 66 to 120 with the shipping gussets.

Figure 31. Coil structural gusset



Section-to-Section Assembly

Air handlers ship with all necessary assembly hardware and gasket material. The hardware should be packaged in either a clear plastic envelope or yellow bag inside the fan section, access section, or mixing box.

The number of sections to be assembled often makes it necessary to use more than one section to ship the assembly material; therefore, check all sections thoroughly before contacting your Trane sales representative to report missing items.

Sections are joined with gasketing applied to one of the mating surfaces and hardware to bolt the sections together. The gasketing for section-to-section joints is a closed cell foam with adhesive backing.

To assemble the unit:

1. Locate the mounting hardware and gasket material.
2. All shipping supports and crating on the face of the sections must be removed and discarded to permit proper fit-up and sealing of the surfaces. Remove any shipping bolts located on the mounting surfaces of the sections (see Figure 32, p. 38).

Figure 32. Section-to-section installation

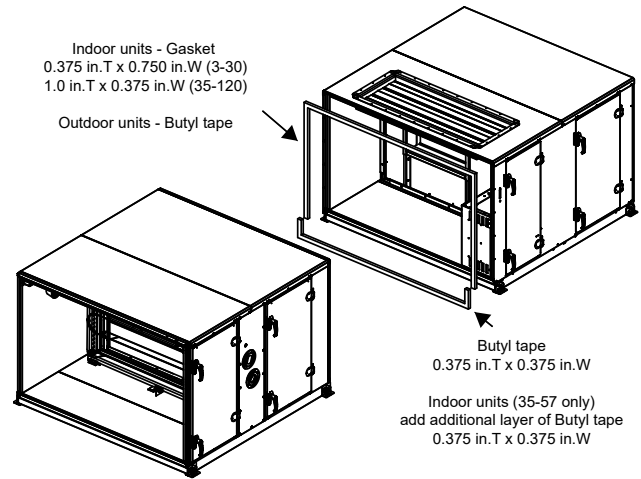

3. Apply the gasketing to one of the mating surfaces; see Figure 32, p. 38, Figure 33, p. 38, and Figure 37, p. 39.

Figure 33. Coil section-to-downstream section bolt up with splash guard

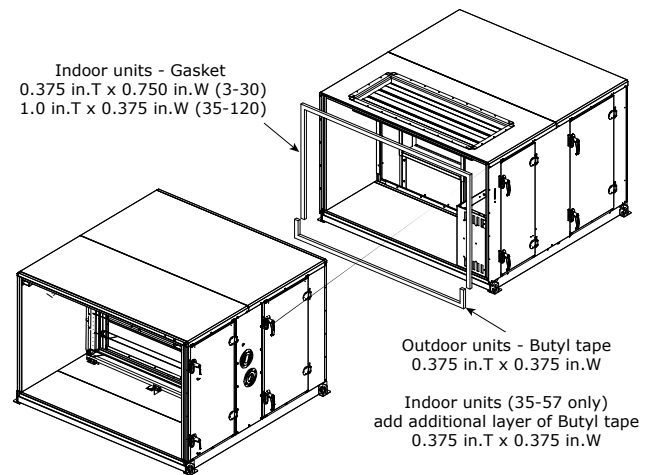

Note: Gasket/Butyl tape should be on outermost edge of panel. See installation in Figure 34, p. 39 and Figure 35, p. 39.

Figure 34. Install Butyl tape to outermost edge of panel

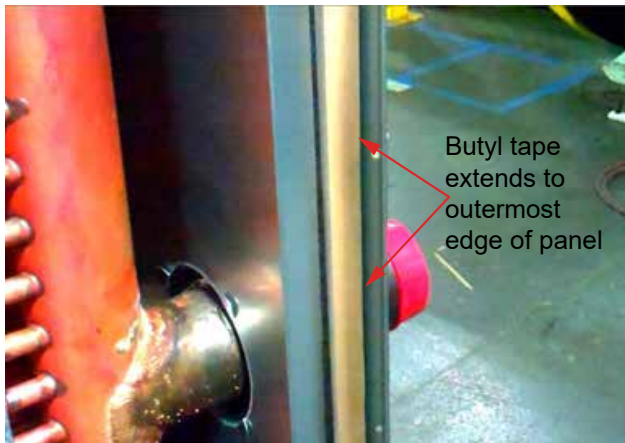

Figure 35. Install gasket to outermost edge of panel



Figure 36. Install butyl tape on outdoor bases



Figure 37. Stacked unit assembly (shown for sizes 3-50)

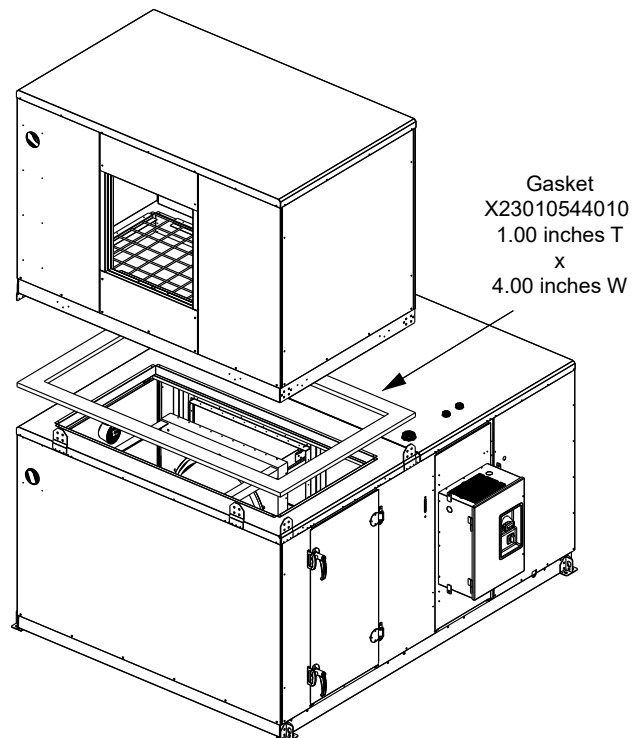

4. If the unit is equipped with factory-mounted controls, move adjacent subassembly within six inches and fasten quick connects where the sections bolt together. See [Figure 38, p. 40](#) for low voltage. See [Figure 39, p. 40](#) and [Figure 40, p. 40](#) high voltage.

Note: Reference the appropriate controller manual for more details on the installation of units with factory-mounted controls.

Figure 38. Horizontal section-to-section low voltage quick connects

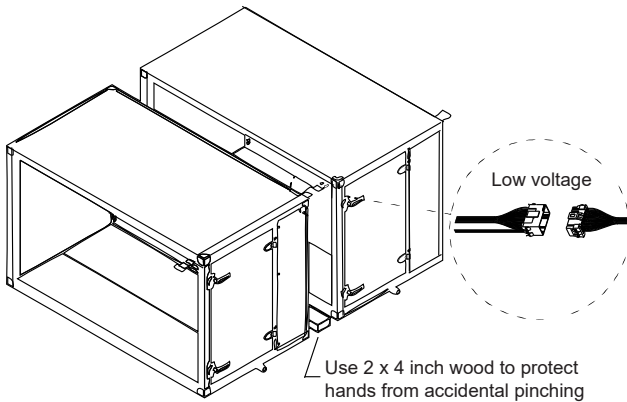
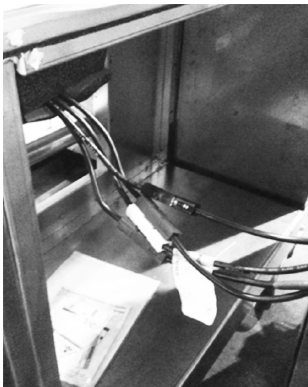
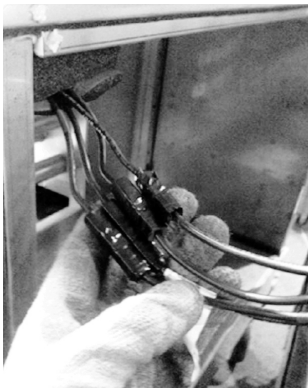

Figure 39. Horizontal section-to-section high voltage quick connects



5. Assemble and seat connections per color code.

Figure 40. Horizontal section-to-section high voltage quick connects



6. Wrap each connection individually with black electrical tape.
7. Fully wrap the connection with tape.

8. Use a bar clamp to pull adjacent shipping section lifting lugs together.
9. For indoor units sizes 66 to 120 and for outdoor units size 40 to 120, a wedge block is provided to aid in pulling and aligning the units together. Attach the wedge blocks to both sides of the units being pulled together, matching the correct wedge block with the correct hole pattern. See [Figure 44, p. 42](#).
10. Verify that the subassembly with the overhang profile on the roof is higher than the mating subassembly. If it is not, raise one end of the subassembly and bring the unit together. See [Figure 41, p. 40](#).
11. Due to unlevel floor and platforms, the roof may be misaligned as shown in [Figure 41, p. 40](#). A common solution is to raise one end of the shipping section to clear the hemming before pulling the units together.

Figure 41. Roof alignment (indoor unit only)

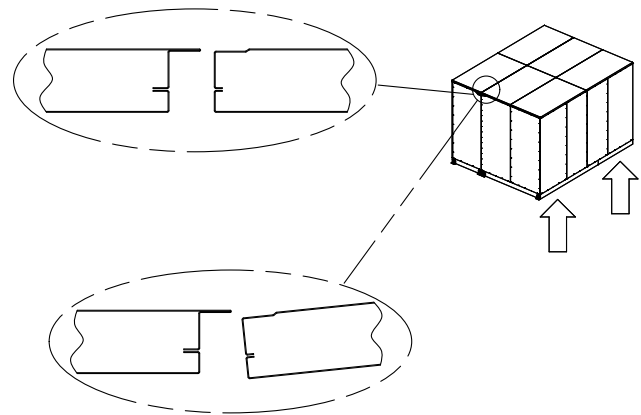

12. In addition, an adjustment can also be made to the height of the roof of either subassembly. At the center (widthwise) of the unit, measure the height of each adjacent subassembly and verify that the subassembly with the overlap sheet metal is higher than the mating subassembly roof. If it is not, adjust the height of either subassembly by loosening the screws in the vertical channels or component structure and adjust the height of the roof. See [Figure 42, p. 41](#) and [Figure 43, p. 41](#)).

Figure 42. Adjust height of roof by adjusting vertical channels

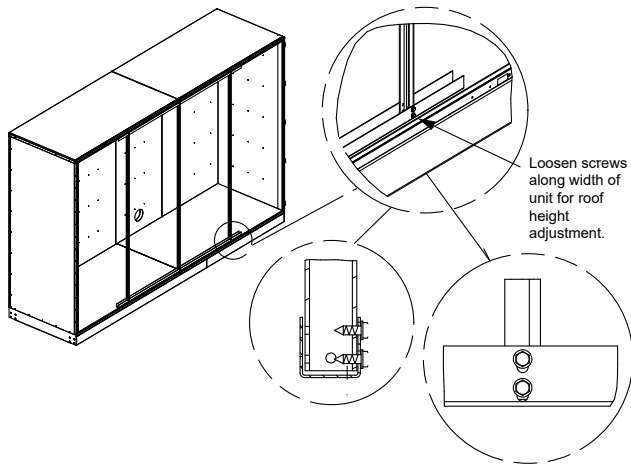
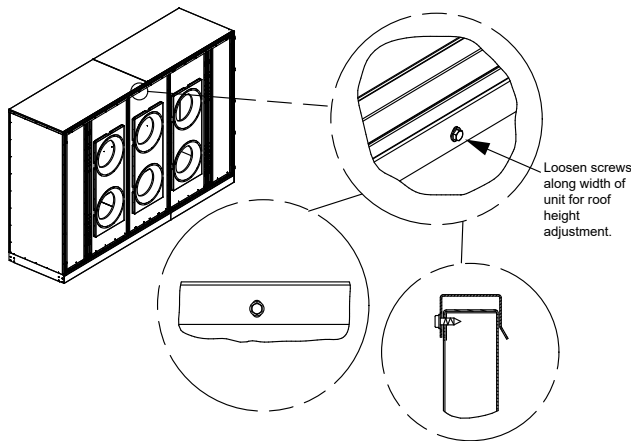

Figure 43. Adjust height of roof by loosening screws



13. For unit sizes 3 to 30, bolt the unit base frames together using 5/16-inch bolts (see [Figure 44, p. 42](#)).
14. For unit sizes 35 to 120, bolt the unit base frames together using 1/2-threaded rod (see [Figure 44, p. 42](#)).
15. For sizes 66 to 120 only, bolt through the wedge blocks using a 1/2-threaded rod (see [Figure 44, p. 42](#)). Alternate between tightening on the lifting lug bolts and wedge block bolts until the shipping section comes together.
16. Use straps and come-alongs to compress the gasketing and pull the sections together along the height of the unit.

Note: *Wedge blocks are used to assemble shipping splits together. Only one set of wedge blocks is shipped with each unit. Once the shipping split has been assembled, remove the wedge blocks and use for the next shipping split.*

Figure 44. Shipping split assembly

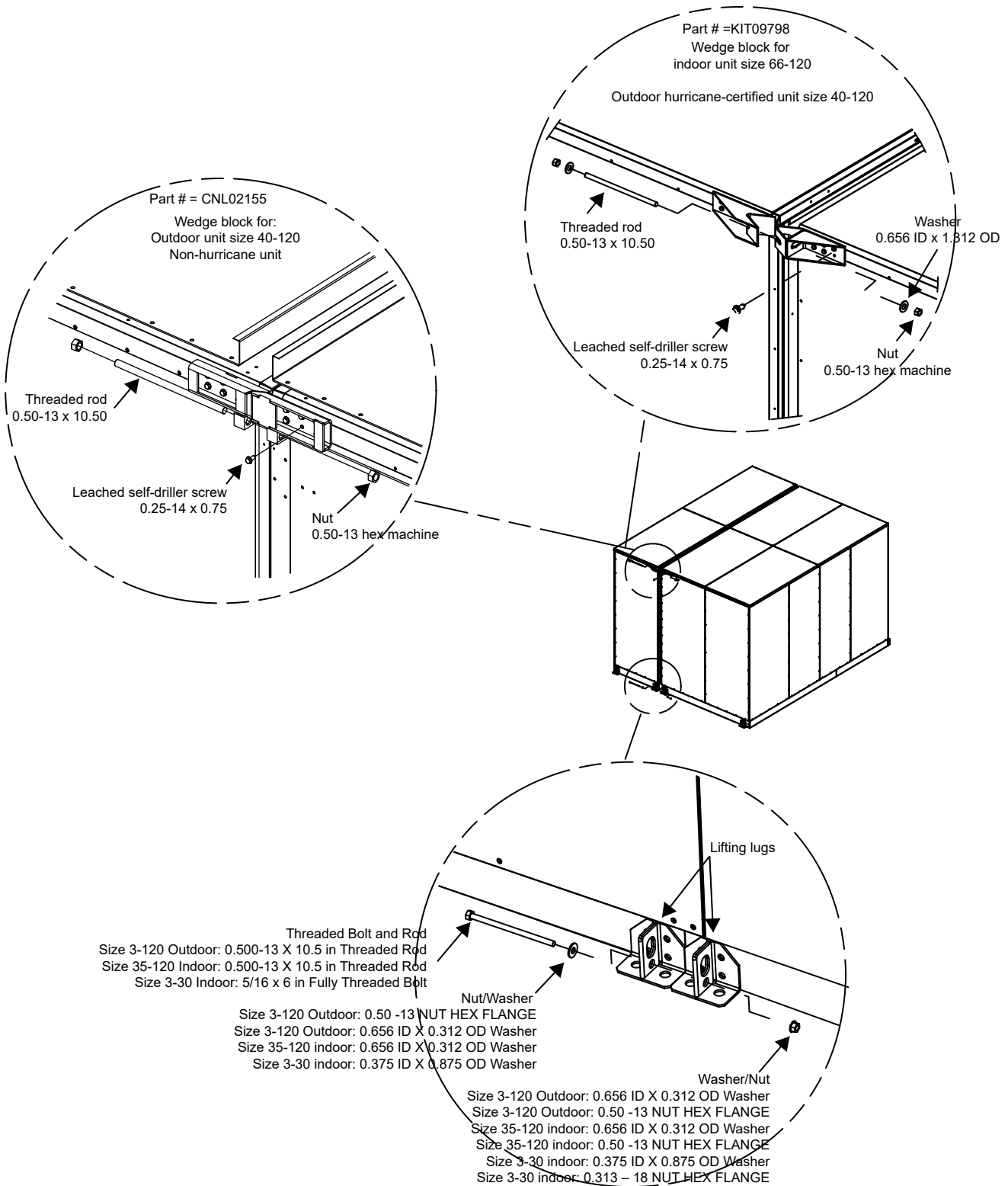

17. Install the section-to-section screws inserting the appropriate screws through the overlapping flanges using a powered impact gun and taking care not to strip the screws. Outdoor air handlers will ship with a seam

cap that is to be installed over the section-to-section seams. Factory-supplied butyl tape must be continuously applied over the top and both side seams prior to seam caps being applied. See [Figure 45, p. 43](#)

Detail A and Detail B for hurricane units for sizes 3 to

120. Detail C applies to non-hurricane units size 3 to 120 (see Figure 47, p. 45).

Figure 45. Section-to-section seam cap installation for hurricane units

Hurricane units

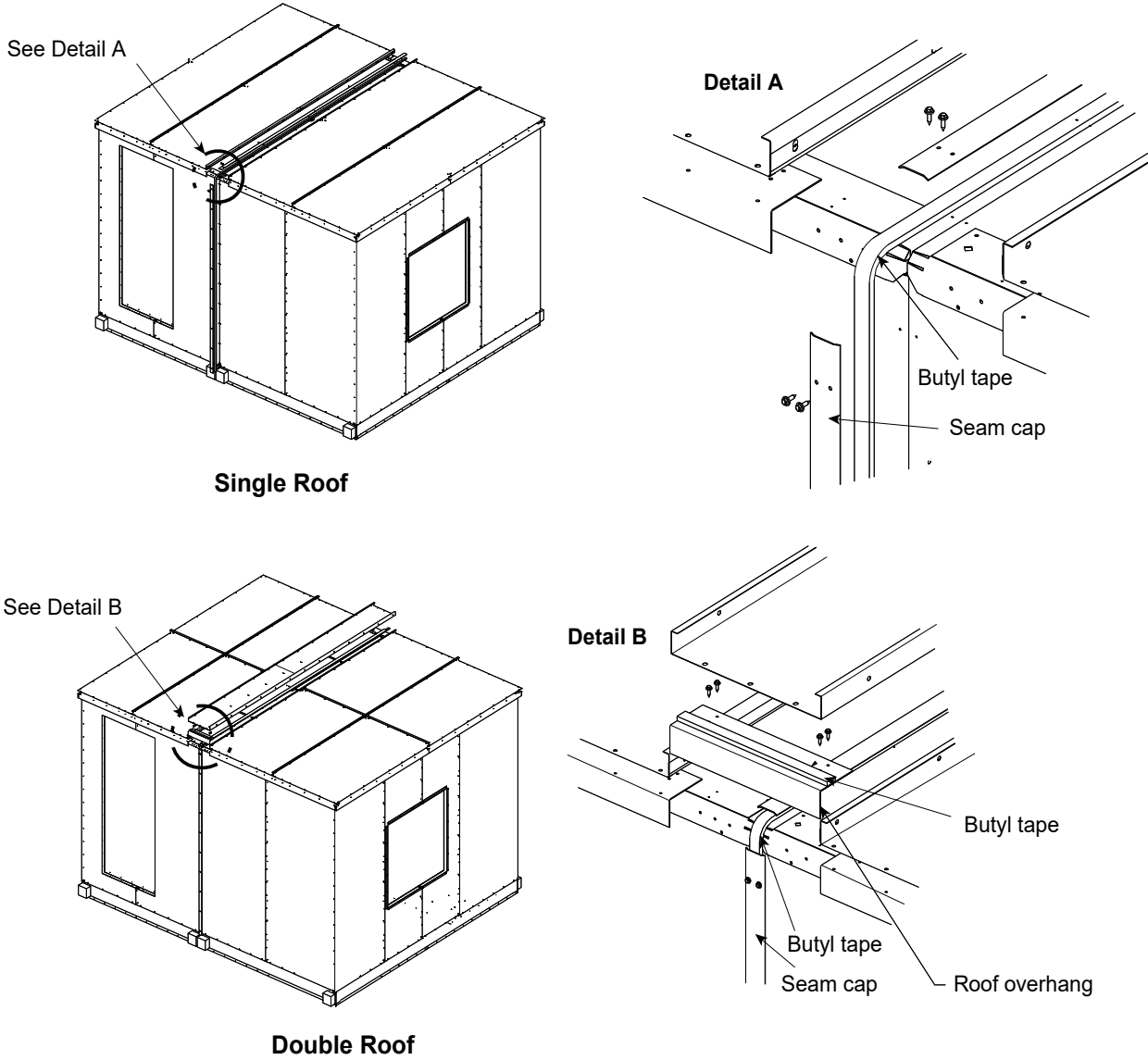

Figure 46. Section-to-section seam cap installation for non-hurricane units (sizes 3 to 35)

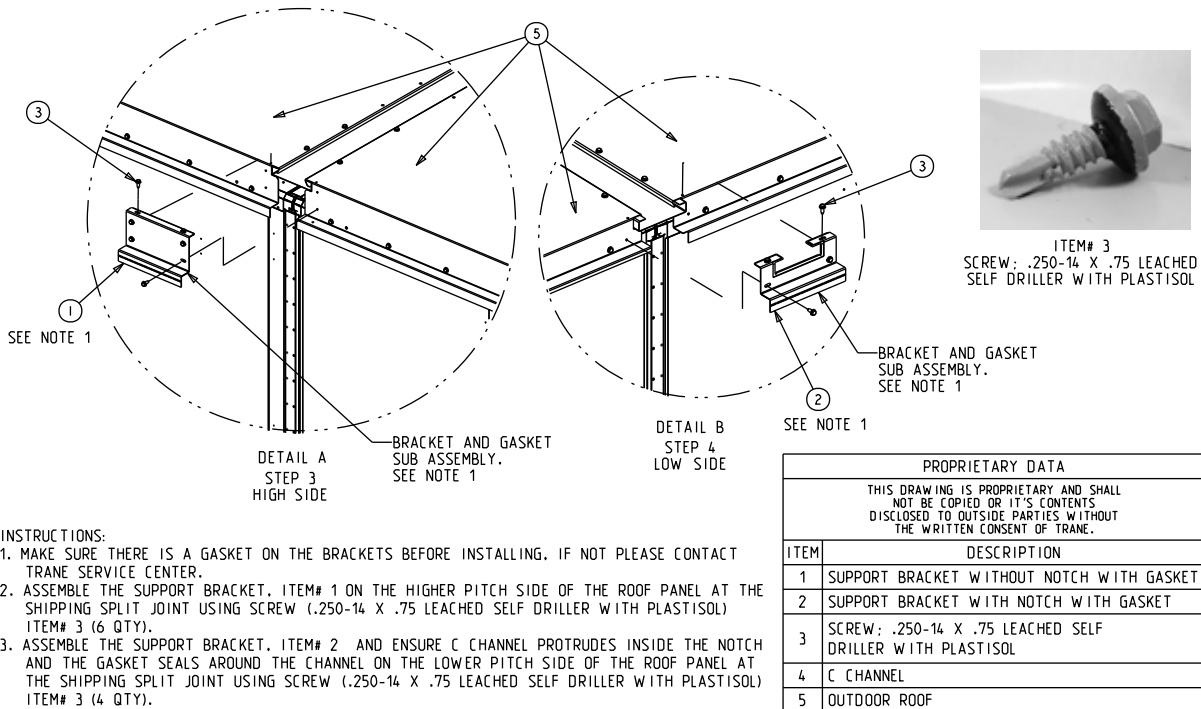
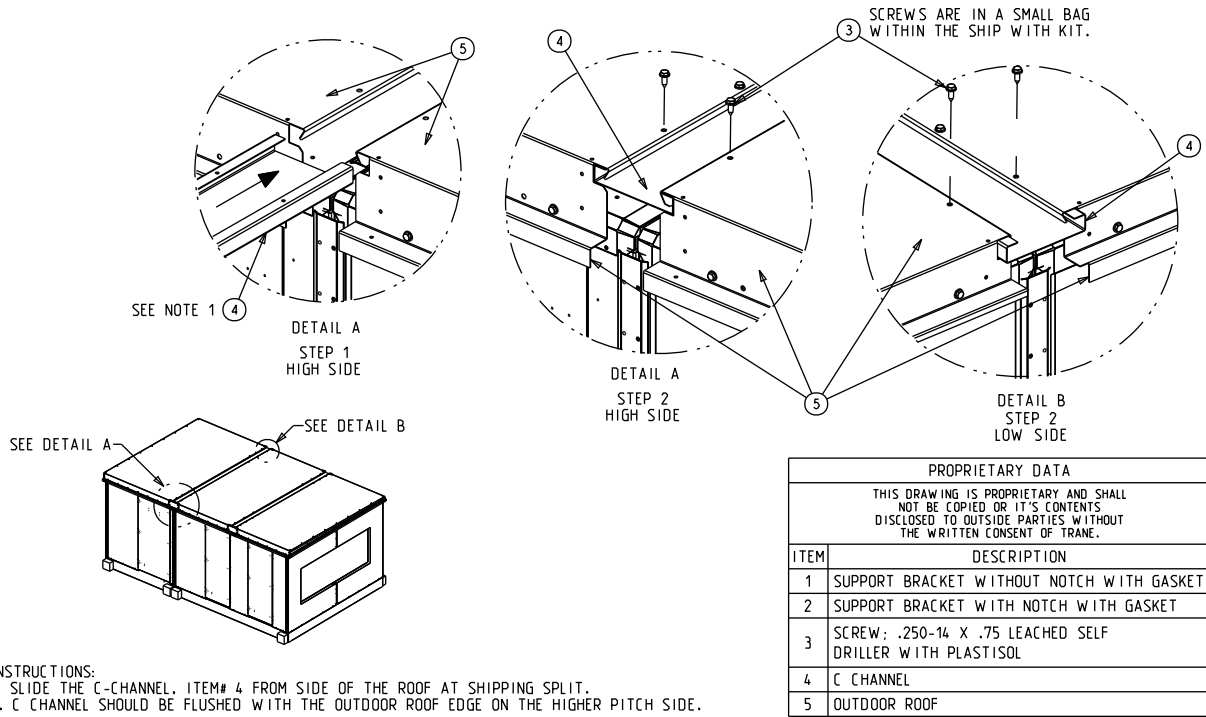
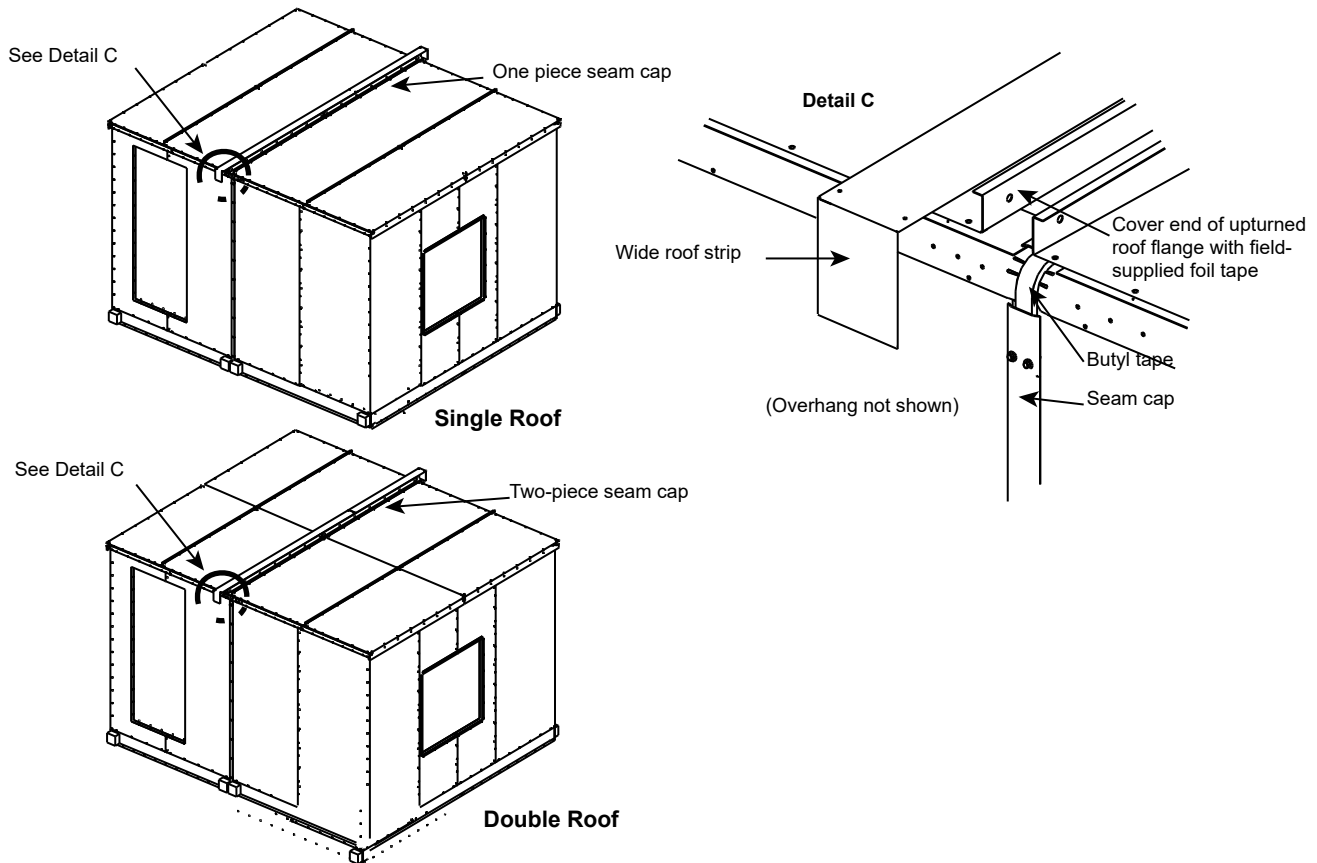
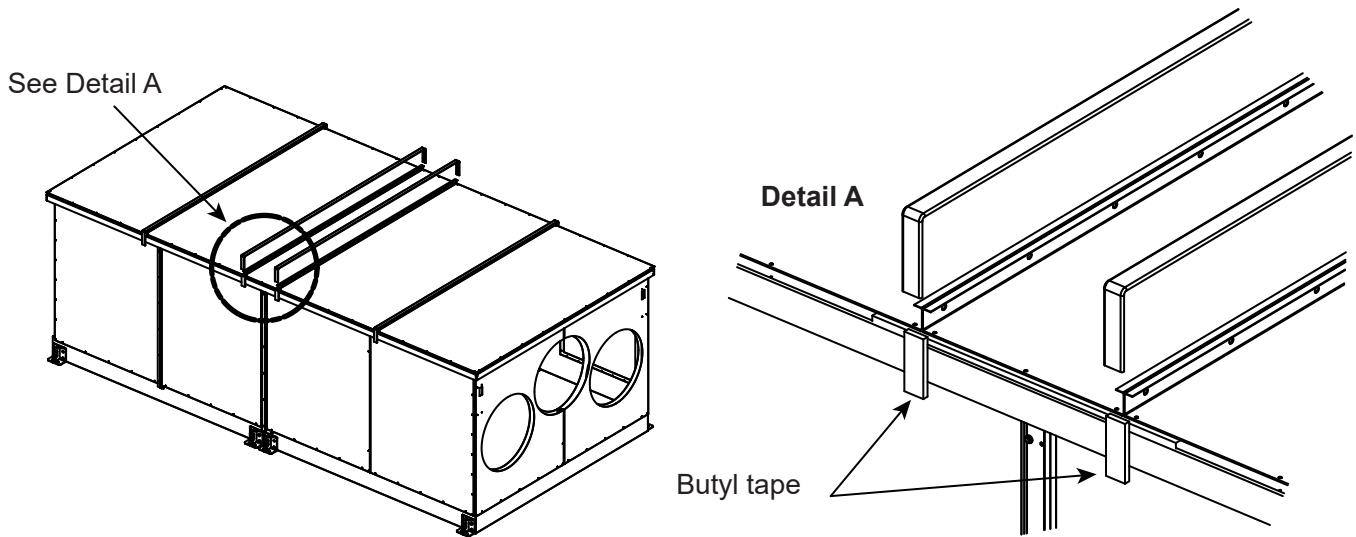

Figure 47. Section-to-section seam cap installation — non-hurricane units sizes 35 (des seq L or earlier) and 40 to 120

18. For sizes 3 through 120 hurricane units, attach roof overhang angle with number 10 screws.
- For sizes 40 through 120 outdoor non-hurricane outdoor units, a wide roof strip is provided. Apply aluminum tape to block off open cavity beneath the overhang angle and roof strip on both sides of unit at the shipping split to prevent unwanted pests from entering.
 - For sizes 3 to 35 outdoor non hurricane units, slide the C Channel between outdoor roofs at the splits.
19. On hurricane units, join outdoor roof panels together at the seams in the direction perpendicular to airflow and

secure them in place with 5/16-inch x 3/4-inch bolts and 5/16 lock nuts. Install the roof joint strip to cover the seam between two outdoor roof panels perpendicular to the direction of airflow. Use 3/8-inch butyl tape to cover the seam between two outdoor roof panels overhang at the side the unit. Bend joint strip over roof panel and use two number 10 sheet metal screws (one in each roof panel) to secure joint strip. Trim the roof joint strip to insure that it does not protrude more than 1/16-inch beyond outdoor roof overhang (see [Figure 48, p. 46](#)).

Figure 48. Join outdoor hurricane roof panels at the seams



Pipe Cabinet Installation

1. After air handler is completely installed and checked to ensure that the unit is level and square, remove cross base member on pipe cabinet base by removing the four bolts and nuts.

2. Add 1-inch x 7.5-inch Armacell[®] gasketing to inside of baserail and add 3/8-inch x 3/8-inch white Butyl[®] tape to face of pipe cabinet. See figures below for appropriate sizes.

Figure 49. Pipe cabinet installation, unit sizes 3 to 35 (des seq L or earlier) and 40 to 120

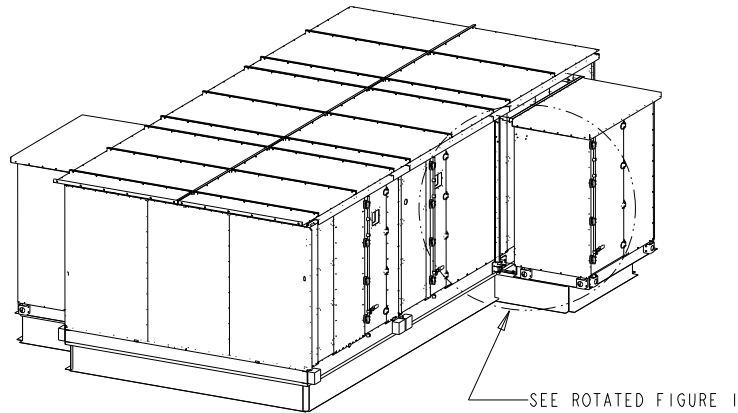

INSTRUCTIONS:

PREPARING FOR PIPE CABINET INSTALLATION:

1. AFTER AIR HANDLER IS COMPLETELY INSTALLED AND CHECKED FOR ACCURACY OF LEVEL AND SQUARE, REMOVE CROSS BASE MEMBER ON PIPE CABINET BASE BY REMOVING THE 4 BOLTS AND NUTS.
2. ADD 1" X 7.5" ARMACELL GASKETING TO INSIDE OF BASERAIL AND ADD 3/8" X 3/8" WHITE BUTYL TAPE TO FACE OF PIPE CABINET. SEE FIGURE 1 AND FIGURE 2.

PROPRIETARY DATA	
THIS DRAWING IS PROPRIETARY AND SHALL NOT BE COPIED OR IT'S CONTENTS DISCLOSED TO OUTSIDE PARTIES WITHOUT THE WRITTEN CONSENT OF TRANE.	
ITEM	DESCRIPTION
1	ARMACELL; 1" x 7.5" x 10' ROLL
2	SCREW; #10-16x0.75"
3	BUTYL; .375" X .375" WHITE
4	ROD; 0.500-13 x 10.5"
5	1/2" NUT
6	1/2" WASHER FLAT
7	PLATE; LUG REPLACEMENT

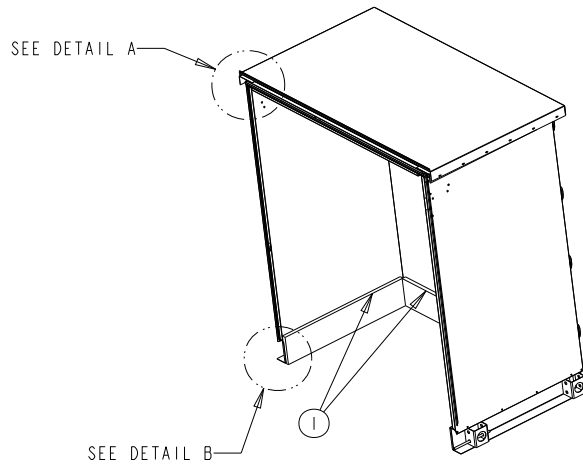
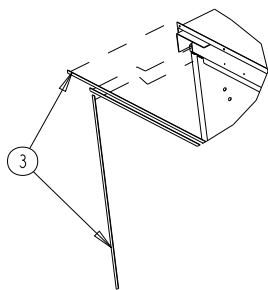
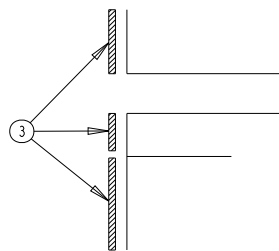

FIGURE 1



DETAIL A



SIDE VIEW

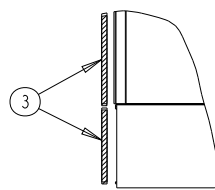

SIDE VIEW

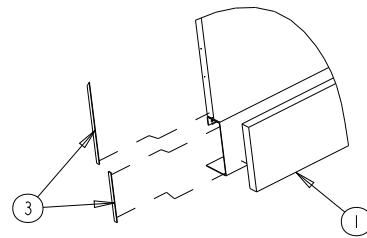

DETAIL B

Figure 50. Pipe cabinet installation, unit sizes 3 to 35 (des seq M or later)

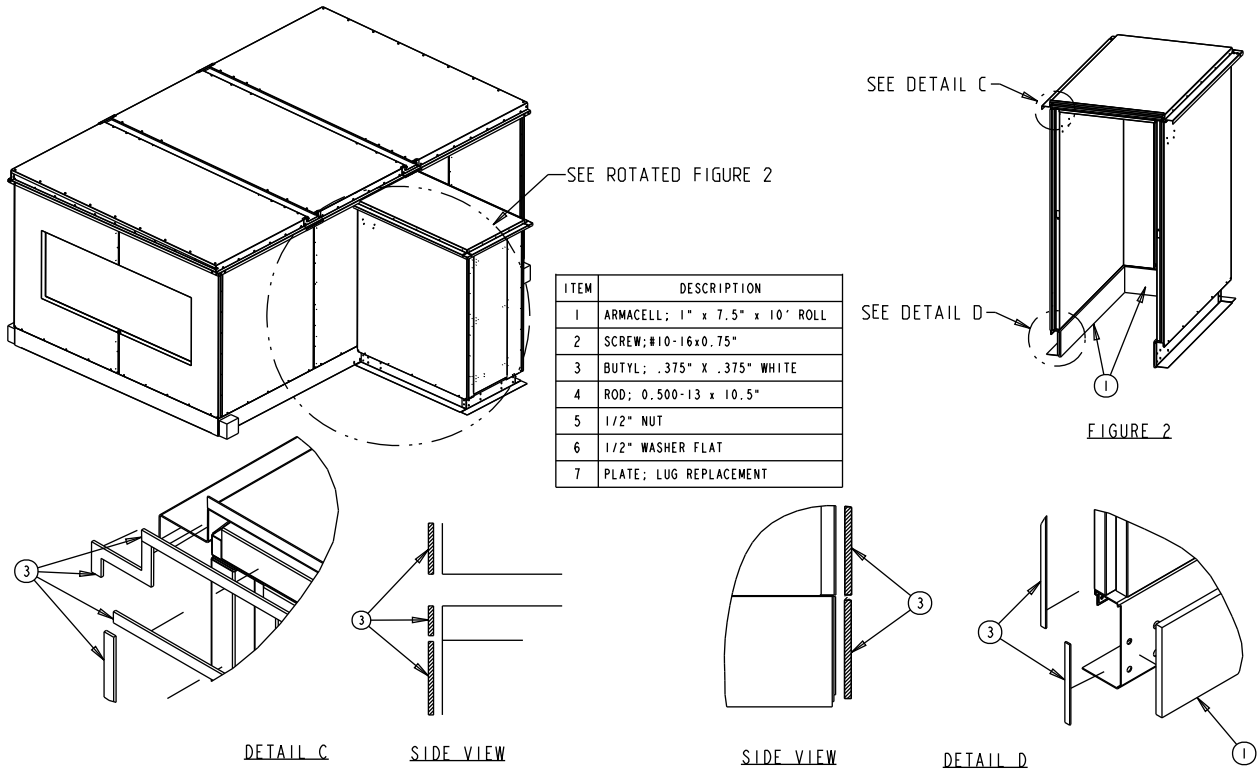

1. Install inside corner cap. See Detail A and Detail B.
2. Install 3/8-inch x 3/8-inch white Butyl tape to unit wall where pipe cabinet roof connects.
3. Lift pipe cabinet roof into place and attach to unit wall with screws. See [Figure 51, p. 49](#).

Figure 51. Pipe cabinet installation details
PIPE CABINET TO BE INSTALLED AT SHIPPING SPLIT JOINT:

1. REMOVE THREADED ROD AND UNIT LUG THAT IS OUTSIDE OF PIPE CABINET.
2. USING 3 SCREWS FROM UNIT LUG, INSTALL BLACK LUG REPLACEMENT PLATE IN PLACE OF UNIT LUG. SEE DETAIL E.
3. LIFT PIPE CABINET INTO PLACE ON ROOF CURB.
4. SLIDE PIPE CABINET INTO PLACE.
5. PUT THREADED ROD THROUGH PIPE CABINET LIFTING LUG INTO WELD NUT INSIDE BASE RAIL TO PULL THE PIPE CABINET TIGHT AGAINST THE UNIT. SEE DETAIL F.

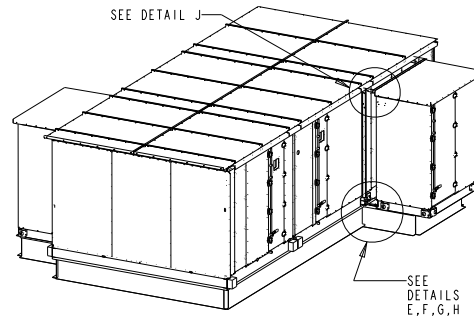
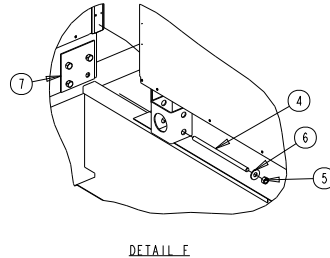
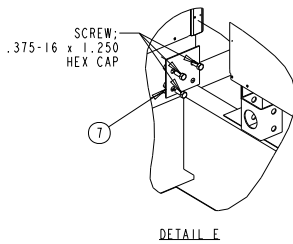
COMPLETING PIPE CABINET INSTALLATION:

1. ADD 3/8" X 3/8" WHITE BUTYL TAPE TO CORNER CAP AND INSTALL CORNER CAP WITH 10-16 X .750 SELF DRILLER SCREWS. SEE DETAIL J.

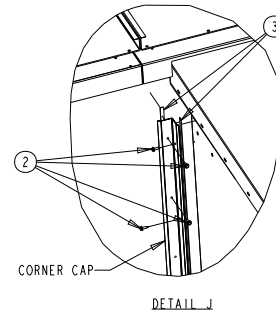
PIPE CABINET TO BE ATTACHED TO UNIT BASE BRACKET:

1. LIFT PIPE CABINET INTO PLACE ON ROOF CURB.
2. SLIDE PIPE CABINET INTO PLACE.
3. PUT THREADED ROD THROUGH PIPE CABINET LIFTING LUG INTO WELDED UNIT BASE RAIL BRACKET TO PULL THE PIPE CABINET TIGHT AGAINST THE UNIT. SEE DETAIL G.

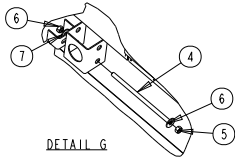
PIPE CABINET TO BE INSTALLED AT FACTORY JOINT:

1. LIFT PIPE CABINET INTO PLACE ON ROOF CURB.
2. SLIDE PIPE CABINET INTO PLACE.
3. PUT THREADED ROD THROUGH PIPE CABINET LIFTING LUG INTO WELD NUT INSIDE BASE RAIL TO PULL THE PIPE CABINET TIGHT AGAINST THE UNIT. SEE DETAIL H.

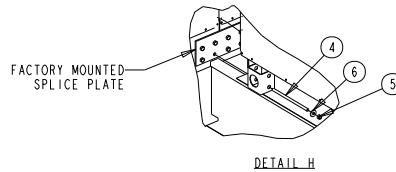
Pipe Cabinet to be Installed at Shipping Split Joint

1. Remove threaded rod and unit lug that is outside of pipe cabinet.
2. Using three screws from unit lug, install black lug replacement plate in place of unit lug. See [Figure 51, p. 49 Detail E](#).
3. Lift pipe cabinet into place on roof curb.
4. Slide pipe cabinet into place.
5. Put threaded rod through pipe cabinet lifting lug into weld nut inside baserail to pull the pipe cabinet tight against the unit. See [Figure 51, p. 49 Detail F](#).

Pipe Cabinet to be Attached to Unit Base Bracket

1. Lift pipe cabinet into place on roof curb.
2. Slide pipe cabinet into place.
3. Put threaded rod through pipe cabinet lifting lug into welded unit base rail bracket to pull the pipe cabinet tight against the unit. See [Figure 51, p. 49 Detail G](#).

Pipe Cabinet to be installed at a Factory Joint

1. Lift pipe cabinet into place on roof curb.

2. Slide pipe cabinet into place.
3. Put threaded rod through pipe cabinet lifting lug into weld nut inside base rail to pull the pipe cabinet tight against the unit. See [Figure 51, p. 49 Detail H](#).

Completing Pipe Cabinet Installation

4. Install inside corner cap. See [Figure 51, p. 49 Detail J](#).
5. Install 3/8-inch. white Butyl tape to unit wall where pipe cabinet roof connects.
6. Lift pipe cabinet roof into place and attach to unit wall with screws. See [Figure 51, p. 49 Detail J](#).

Hood Installation

1. Per the unit drawing determine mounting location of the unit weather hoods.
2. Using the factory provided screws mount the weather hoods to the unit.
3. On larger units, weather inlet hurricane and exhaust hoods may be large enough to require angled down supports. In those cases, the angles are shipped attached to the hood but will need to be connected to the air handler by the installing contractor. See [Figure 52, p. 50](#).

Note: It is required that the hoods be sealed to the unit using factory-provided butyl/caulk tape.

Figure 52. Inlet hurricane and exhaust hood installation

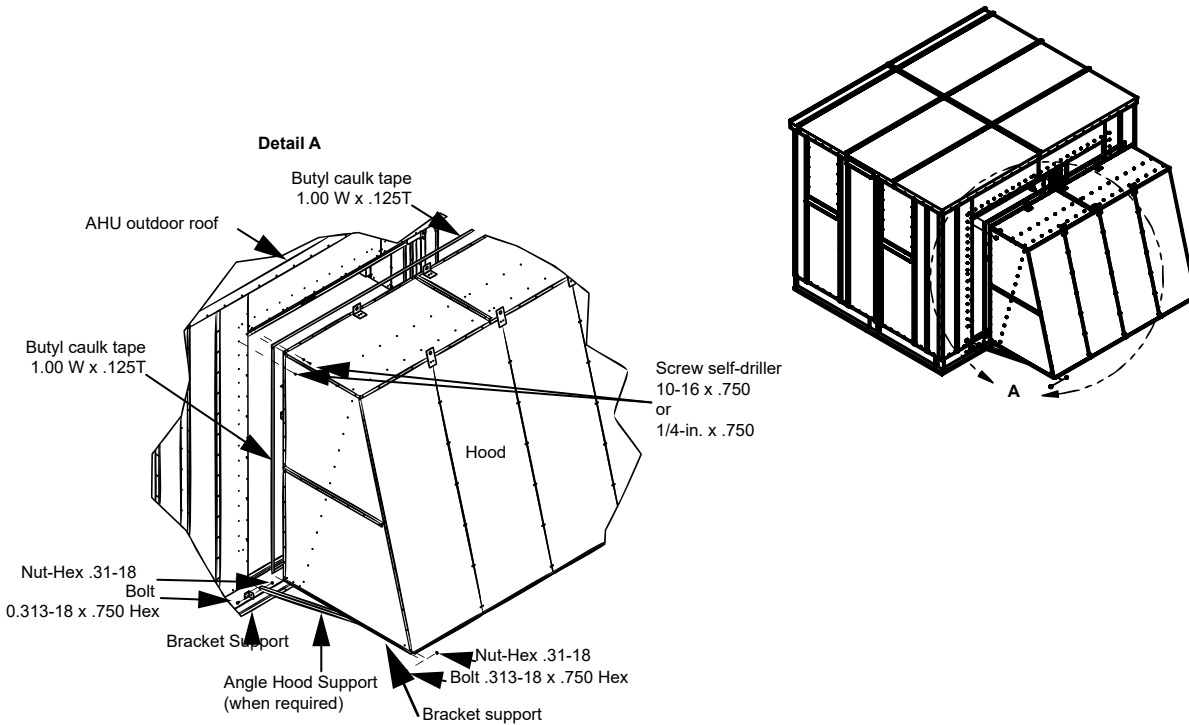

4. Install Exhaust Hood such that it discharges away from any adjacent intake hoods. Exhaust discharge location can be changed on installation by rotating the hood.

5. Units with multiple standard inlet hoods require that the hoods be installed from bottom to top. Overlap locations should be sealed with butyl caulk between the hoods. See [Figure 53, p. 50](#).

Figure 53. Standard inlet hood installation

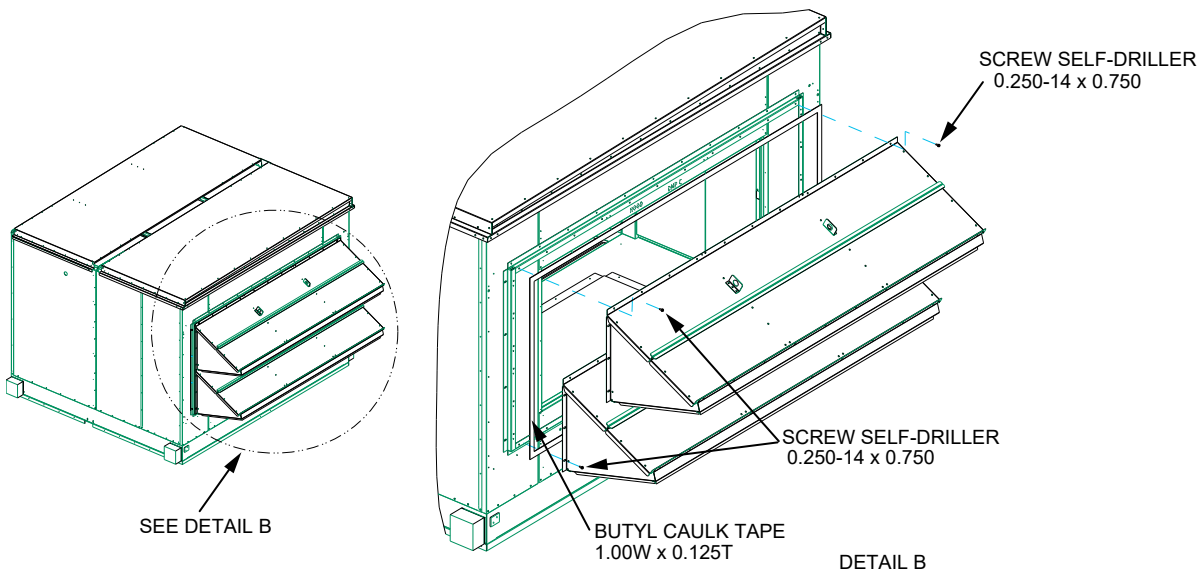
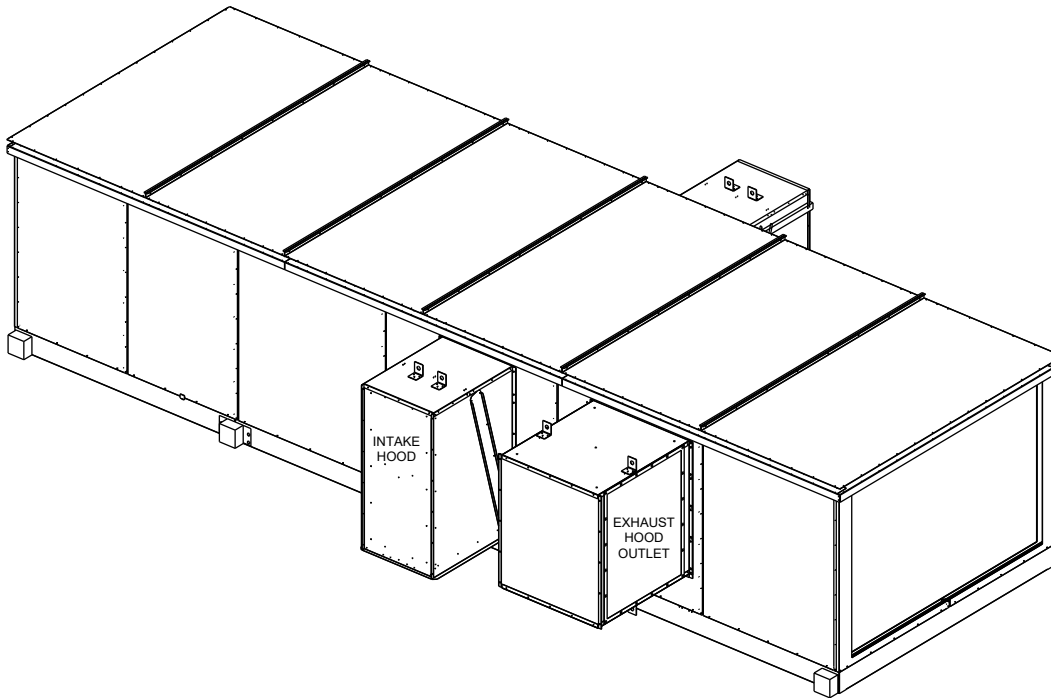

Figure 54. Fan section side discharge exhaust hood installation (intake hood shape varies)



Stacked Outdoor Unit Assembly

Assembly Hardware

Table 13. Parts list for outdoor stacked units

Item	Description
1	Gasket: 1.00T x 4.00W
2	Bracket: Stacked unit
3	Screw: 0.313-18 x 0.875 sheet metal
4	Screw: 10-16 x 0.750 self driller
5	Tape: Butyl 0.38T
6	Tape: Ribbed Butyl
7	Plate: Vertical seam cap
8	Tape: 0.12T x 1.00W, gray Butyl
9	Guard: perpendicular to airflow flashing
12	Guard: Direction of airflow flashing
13	Guard: Flashing seam cover
14	Adhesive/sealant: Flex polyurethane
15	Bracket: Hood support

Table 13. Parts list for outdoor stacked units (continued)

Item	Description
16	Angle: Hood support
17	Screw: 0.250-14 x 0.750 self driller

Unit Assembly

1. See [Figure 55, p. 52](#). Apply gasket (Item 1) on top of lower unit. Compress gasketing to ensure a good air seal between upper and lower sections.
2. Place upper unit on lower unit.
3. Remove lifting lugs from top unit and attach stacking brackets (Item 2) to top and bottom units using screws (Item 3 and Item 4). See Detail A in [Figure 55, p. 52](#). Stacking brackets (Item 2) are to be used on the right and left sides at each shipping split section end and also on front and back of the unit.
4. Apply Butyl tape (Item 5) to one side of the shipping split section.
5. Slide shipping split sections together, pulling tight using lifting lugs and threaded rod on bottom and straps or pipe clamps on top.

Figure 55. Stacked unit assembly

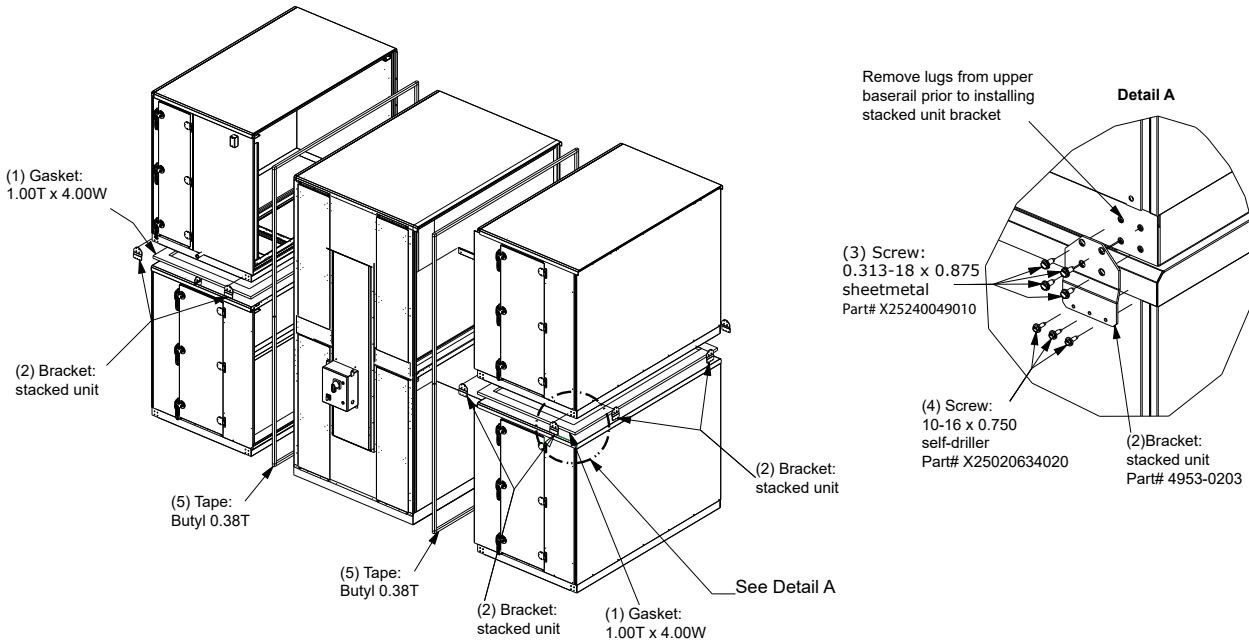

Vertical Seam Cap Installation

1. See [Figure 56, p. 52](#). Apply ribbed Butyl tape (Item 6) over all vertical shipping split seams (see [Detail A](#)). First level ribbed Butyl tape (Item 6) starts 1/2-inch below second level wall panel (see [Detail B](#)), and extends down beyond the bottom of the first level wall panel onto the base rail at least one inch (see [Detail C](#)). Second level ribbed Butyl tape (Item 6) starts at bottom of wall panel on second level (see [Detail B](#)) and runs up to the top of the second level wall panel.

2. Secure vertical seam cap (Item 7) over ribbed Butyl tape (Item 6) with screws (Item 4) (see [Detail A](#)). First level vertical seam cap (Item 7) starts at bottom of hem on roof panels (see [Detail B](#)) and extends down onto the base rail at least one inch (see [Detail C](#) in [Figure 56, p. 52](#)). Vertical seam cap (Item 7) on second level starts at bottom of wall panel and extends up (see [Detail B](#)). Second level vertical seam cap (Item 7) may extend onto the roof panel.

Figure 56. Vertical seam cap installation

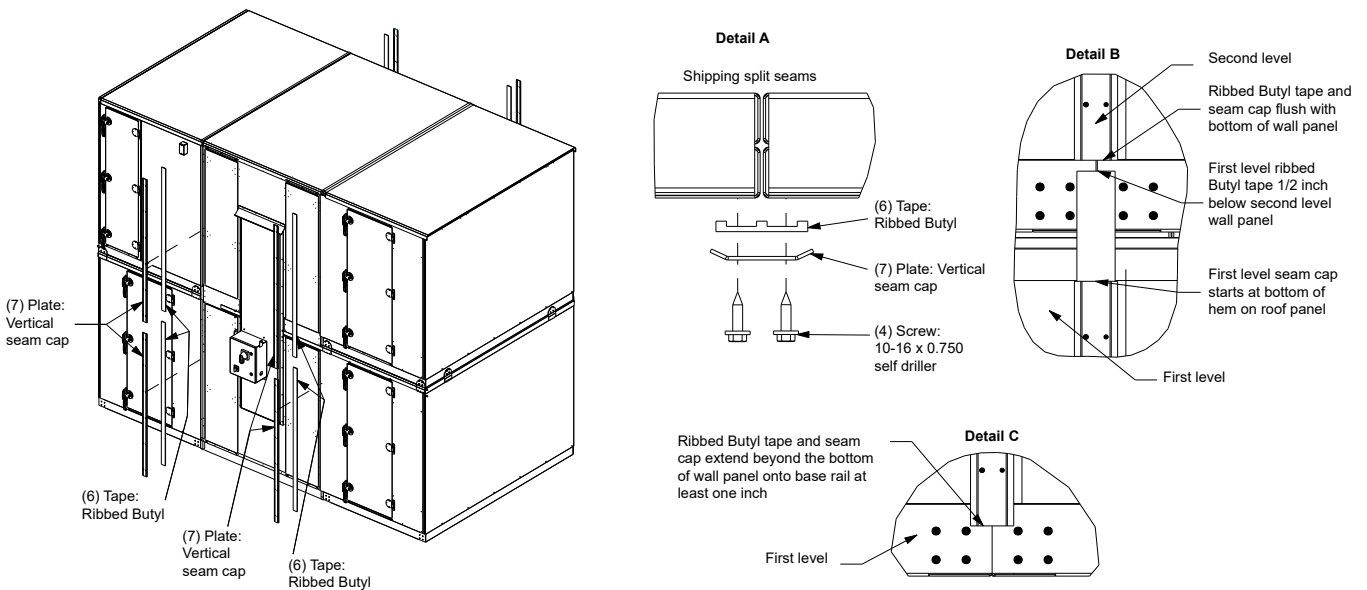

Flashing Installation

For additional information, see “Flashing Installation Notes,” p. 57.

For hood installations, see “Install Flashing and Hood,” p. 58.

1. See Figure 57, p. 53. Apply Butyl tape (Item 8) to perpendicular-to-airflow flashing (Item 9) and secure to base rail with screws (Item 4) on front and back of unit (see Detail A in Figure 61, p. 54).
2. For energy wheel/CDQ wheel, preassemble end covers (Item 10 and Item 11) to direction-of-airflow flashing (Item 12) with screws (Item 4). Apply caulk (Item 14) to

create water tight seal (see Detail B in Figure 59, p. 54).

3. Apply Butyl tape (Item 8) to direction-of-airflow flashing (Item 12) and secure to base rails with screws (Item 4). Start at corners to ensure tight corner seams. Apply caulk (Item 14) to create water-tight seal (see Detail A and Detail C in Figure 60, p. 54).
4. Install seam covers (Item 13) to all flashing seams (see Detail D in Figure 61, p. 54).

If second level of unit is shorter than first level, see “Flashing Installation for Stacked Unit With Second Level Shorter Than First,” p. 54.

Figure 57. Flashing installation

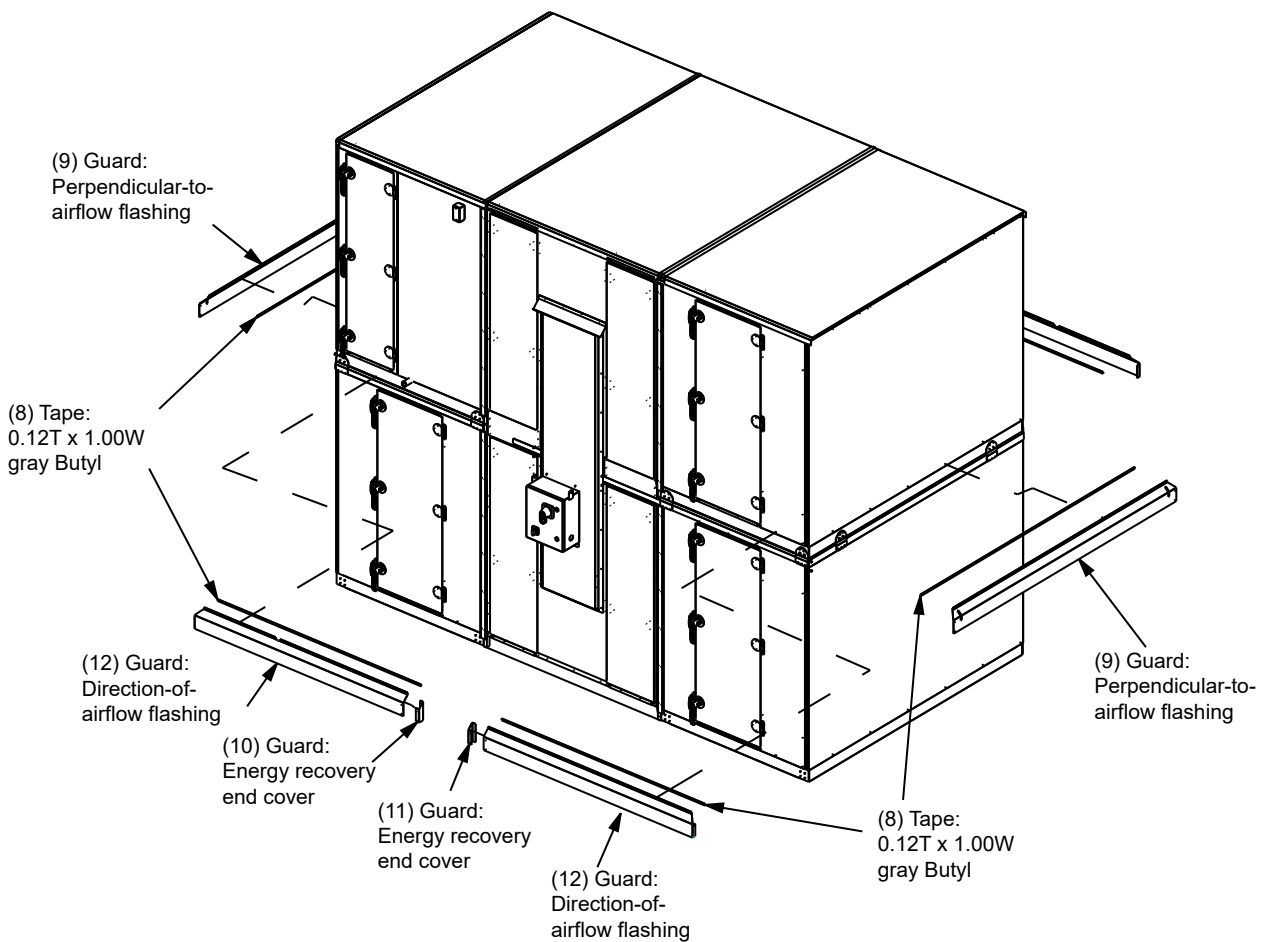

Figure 58. Flashing installation location

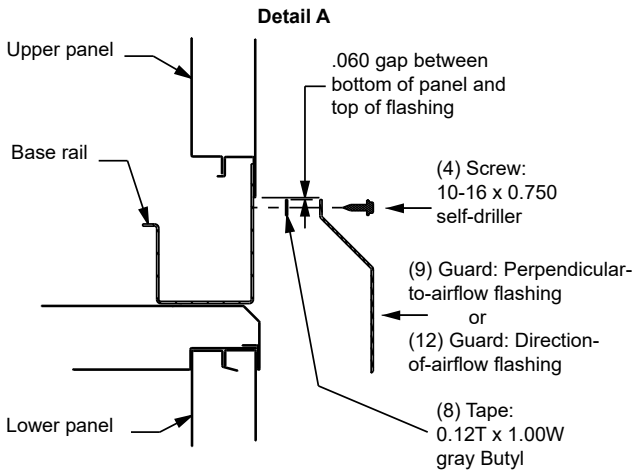

Figure 59. Flashing end cover installation applied to energy wheels and CDQ sections

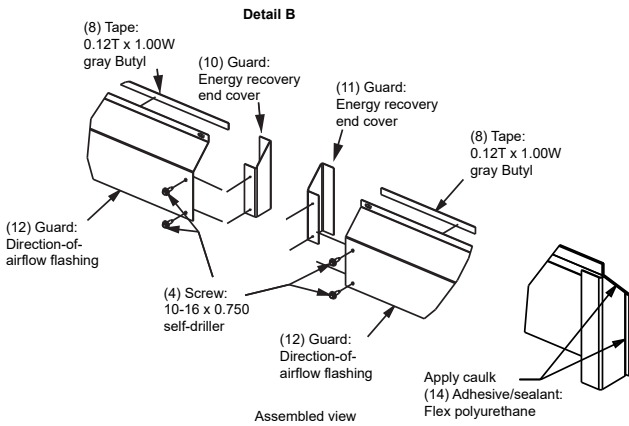

Figure 60. Flashing for corner seams

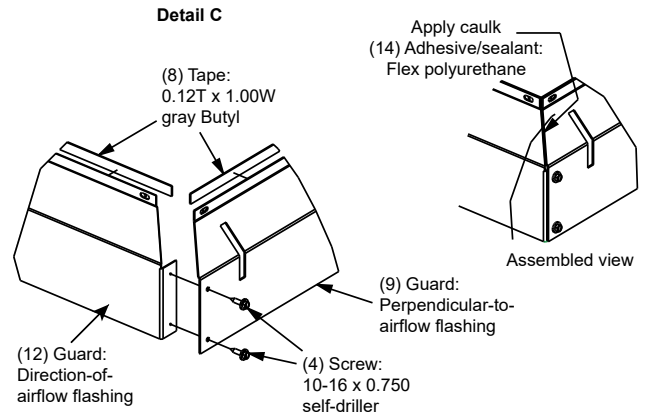
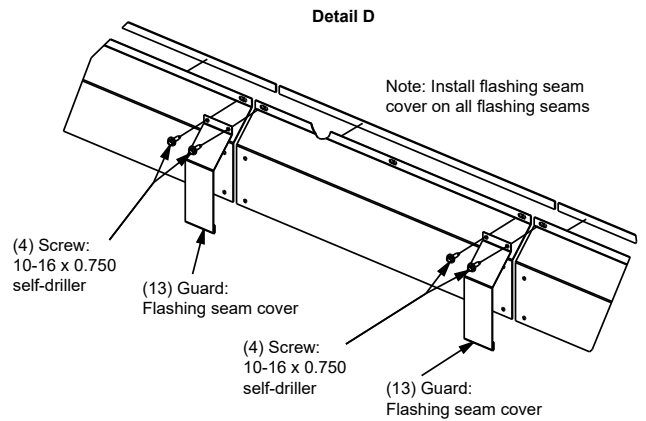

Figure 61. Flashing seam cover installation



**Flashing Installation for Stacked Unit With Second Level Shorter Than First
Sizes 3 to 35 (des seq M or later)**

Figure 62. Internal width 27.5 to 96 in. (des seq M or later), non-hurricane units (part 1 of 2)

STEPS FOR FLASHING INSTALLATION:

1. FOR FLASHING INSTALLATION NOTES, SEE SHEET 8.
2. APPLY CAULK (ITEM 14) FOR OUTDOOR ROOF TO BASE RAIL TO CREATE WATER TIGHT SEAL (SEE DETAIL J ON SHEET 6).
3. APPLY BUTYL TAPE (ITEM 8) TO DIRECTION OF AIR FLOW FLASHING (ITEM 12) AND SECURE TO BASE RAILS WITH SCREWS (ITEM 4), STARTING AT CORNERS TO ENSURE TIGHT CORNER SEAMS. APPLY CAULK (ITEM 14) TO CREATE WATER TIGHT SEAL (SEE DETAIL F AND G ON SHEET 4).
4. INSTALL SEAM COVERS (ITEM 13) TO ALL FLASHING SEAMS (SEE DETAIL H ON SHEET 4).
5. ASSEMBLE SKIRT BRACKET (ITEM 18) USING SCREW (ITEM 4) WITH FLASH GUARD (ITEM 12) AT HIGHER PITCH SIDE (SEE DETAIL K SHEET 7).
6. ASSEMBLE SKIRT BRACKET (ITEM 19) USING SCREW (ITEM 4) WITH OUTDOOR ROOF PANEL AT LOWER PITCH SIDE (SEE DETAIL L SHEET 7).

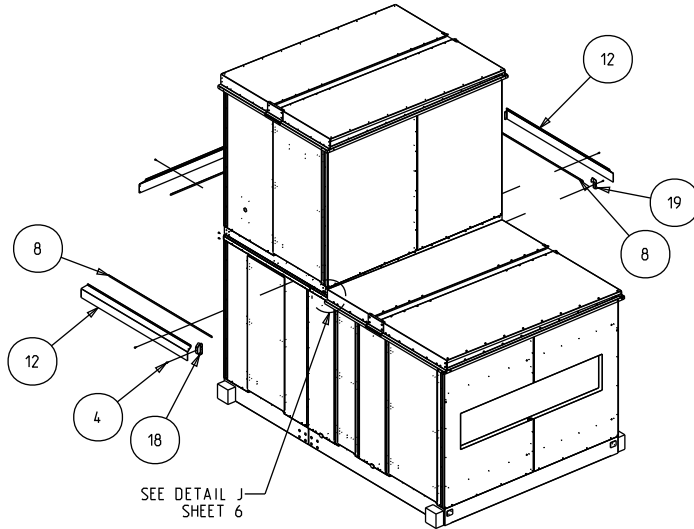

PROPRIETARY DATA	
THIS DRAWING IS PROPRIETARY AND SHALL NOT BE COPIED OR ITS CONTENTS DISCLOSED TO OUTSIDE PARTIES WITHOUT THE WRITTEN CONSENT OF TRANE	
ITEM	DESCRIPTION
4	SCREW; 10-16 X 0.750 SELF DRILLER
8	TAPE; 0.12T X 1.00W, GRAY BUTYL
12	GUARD; DIRECTION OF AIR FLOW FLASHING
13	GUARD; FLASHING SEAM COVER
14	ADHESIVE/SEALANT; FLEX POLYURETHANE
18	SKIRT SUPPORT BRACKET
19	SKIRT SUPPORT BRACKET

DETAIL J
STACKED OUTDOOR ROOF PANEL INSTALL

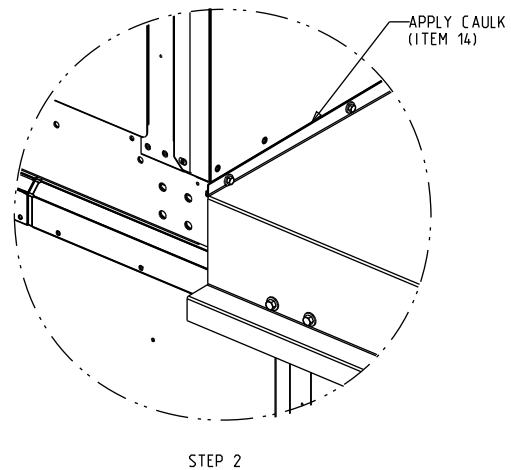
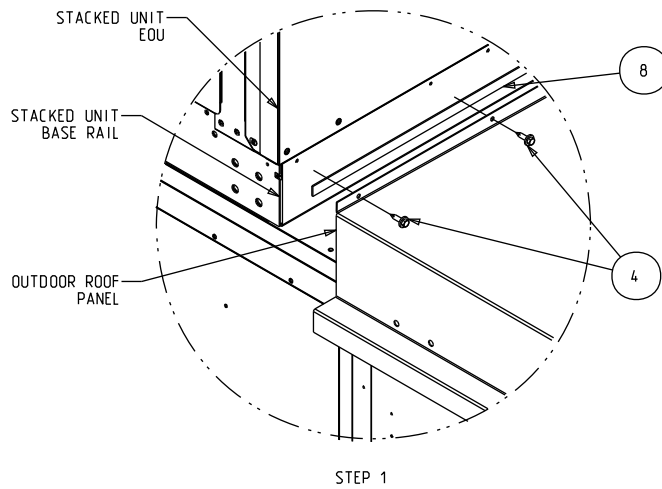
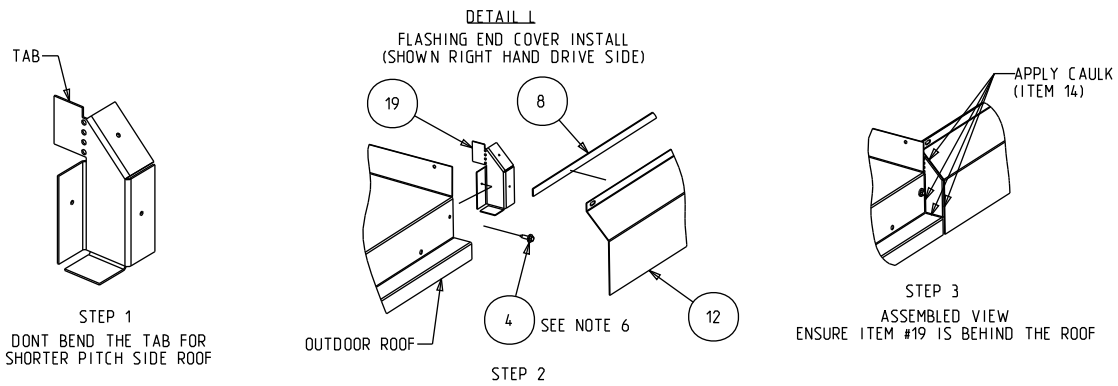
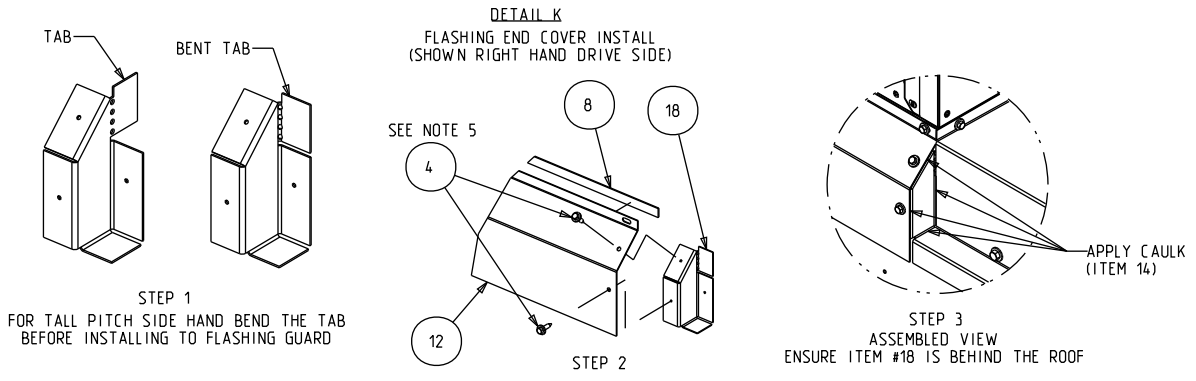

Figure 63. Internal width 27.5 to 96 in. (des seq M or later), non-hurricane units (part 2 of 2)



Sizes 3 to 35 (Design Sequence L or earlier) and 40 to 50

1. Ensure that first level roof section is properly sealed with Butyl tape (item 8) and/or caulk (Item 14) at the ends. See [Figure 64, p. 56](#).

Figure 64. Seal first level with caulk or Butyl tape

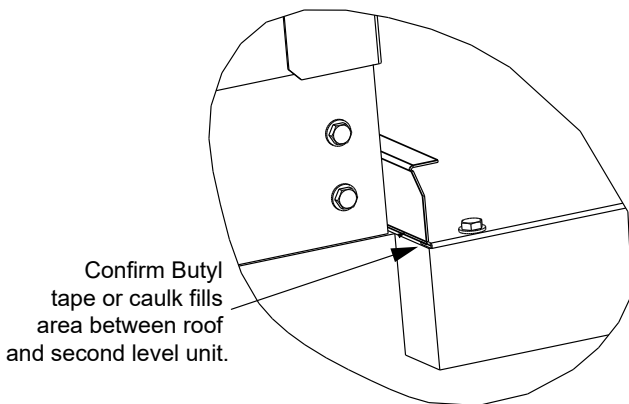

2. Bend end tabs by hand and apply Butyl tape (Item 8) to flashing. See [Figure 65, p. 56](#).

Figure 65. Bend end tabs and apply Butyl tape to flashing



3. Secure to base rail with screws (Item 4).
4. Apply caulk (Item 14) to ensure a water tight seal. See [Figure 66, p. 57](#).

Figure 66. Apply caulk to seal

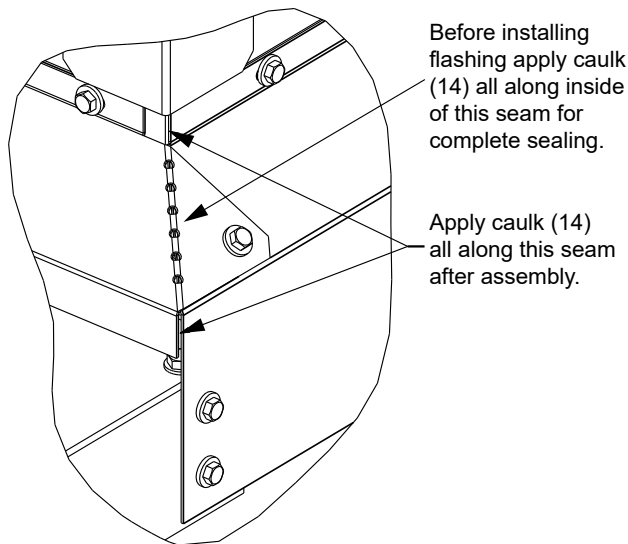

- For unit size 50 with a two piece roof, additional sealing is required in the middle where the first level roof sections meet with second level baserail. Seal vertical flanges of roof with caulk (Item 8) prior to installing flashing. Once flashing is installed, apply caulk (Item 8) to joint, then install direction of airflow roof strip and smooth caulk into crevices to ensure a water tight seal. See Figure 67, p. 57.

Figure 67. Flashing installation for perpendicular-to-airflow piece if second level of unit is shorter than first level

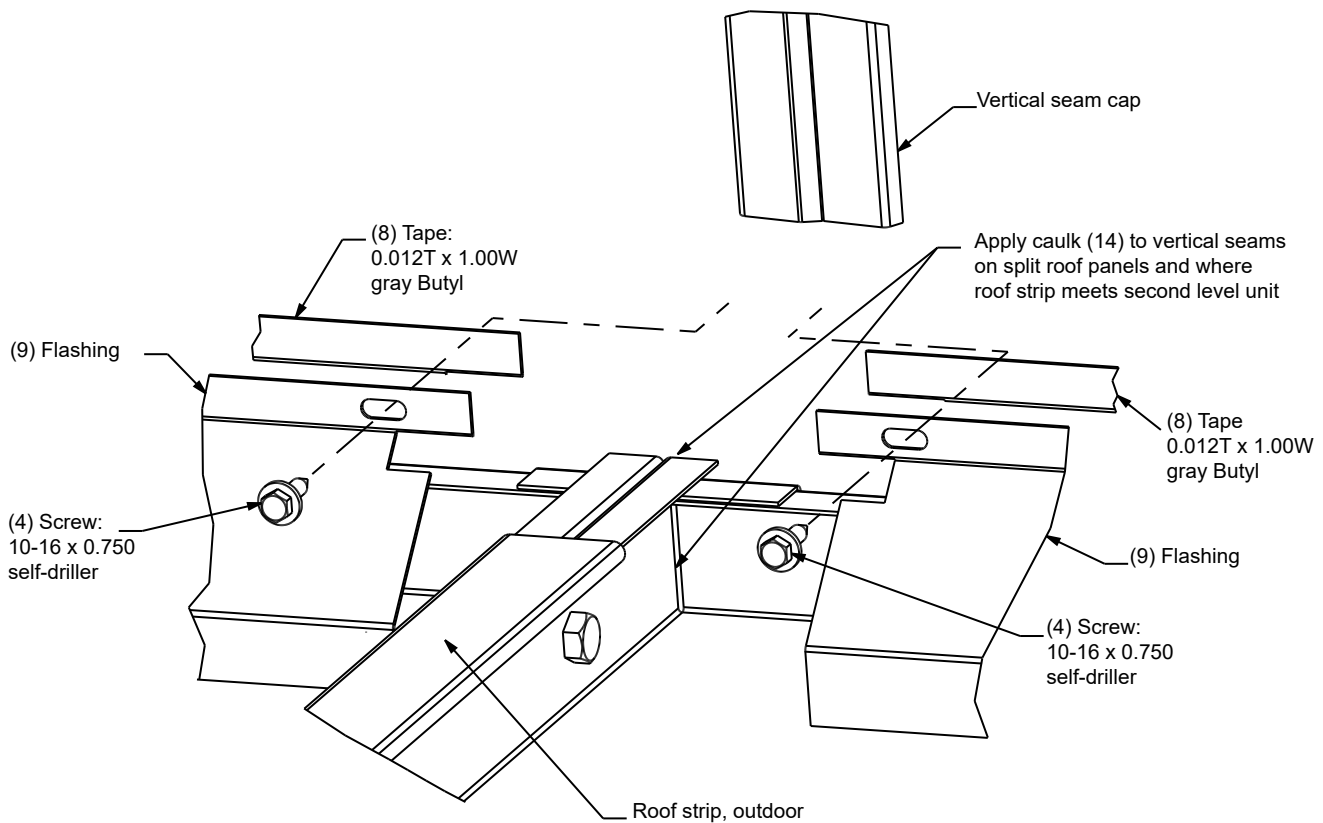

Flashing Installation Notes

- Side flashing will have locating features:
 - Right side front and back pieces will have two diamonds and a tab. Intermediate right side pieces (if present) will have two diamonds and length of part will match the ship group length and mounting holes will match hole pattern on the unit.
 - Left side front and back pieces will have one diamond and a tab. Intermediate left side pieces (if present) will have one diamond and length of part will match the ship group length and mounting holes will match hole pattern on the unit.
- Flashing runs full length on right/left sides of unit except on access side when an energy recovery section is present. For energy recovery section without full height

doors, flashing will extend to removable plug panel. For energy recovery section with full height doors, flashing will be flush with edge of vertical seam caps (see Detail A in Figure 68, p. 58).

- Flashing runs full length on front/back of unit. Front/back flashing will not have any locating features and will always have mitre (one piece will have two mitres, two pieces will have one mitre).

Figure 68. Side flashing installation

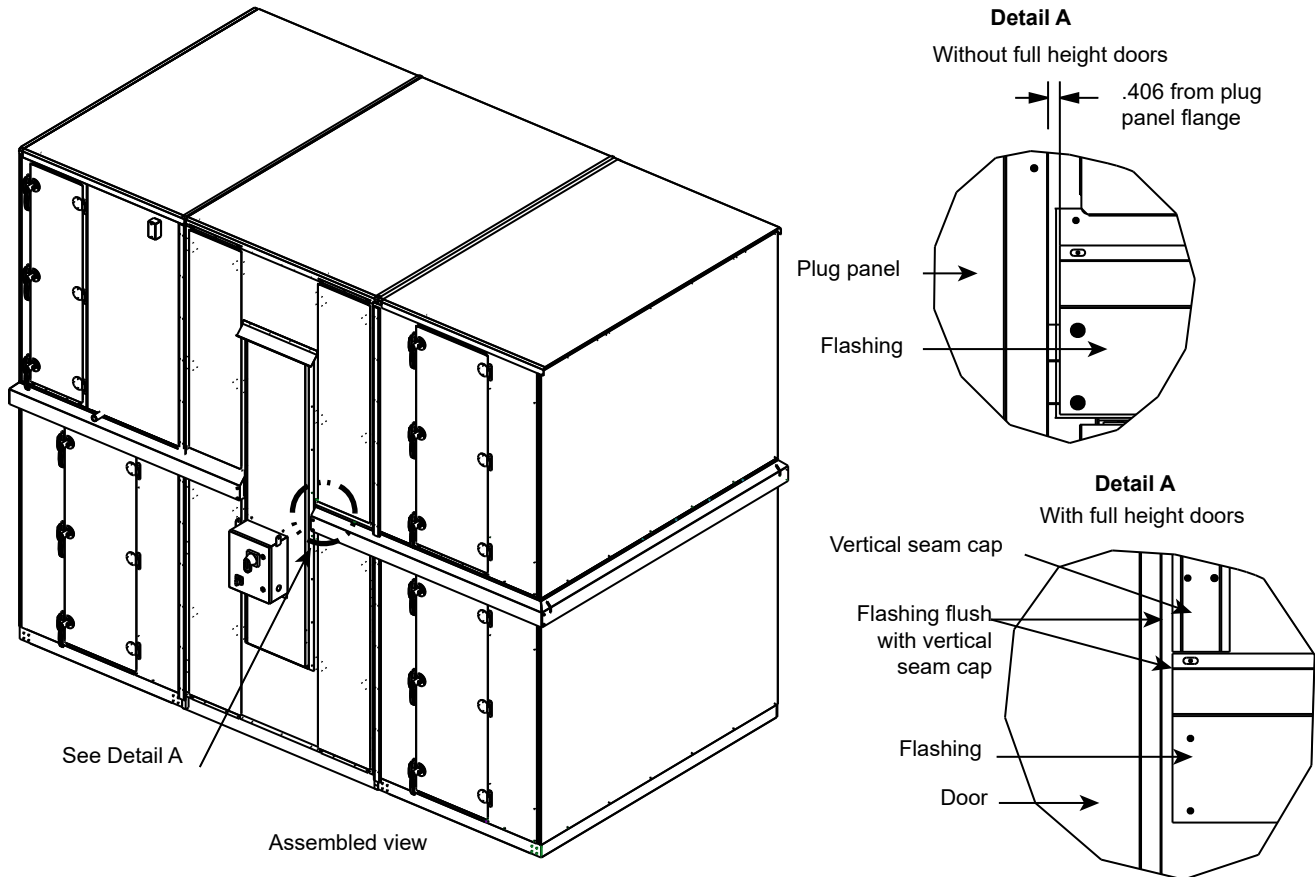

Install Flashing and Hood

1. See Figure 69, p. 59. Secure two hood support brackets (Item 15) to base rail with screws (Item 17).
2. Apply Butyl tape (Item 8) to flashing (Item 9) and place over hood support brackets (Item 15) using cut in flashing and secure to base rails with screws (Item 4).
3. See "Hood Installation," p. 49 for hood installation instructions.
4. Secure hood support angles (Item 16) to hood support brackets (Item 15) and to the hood side panels with screws (Item 17).
5. Apply caulk (Item 14) around hood support bracket (Item 15), hood support angle (Item 16), and cutout in perpendicular-to-airflow flashing (Item 9) to ensure watertight seal.

Figure 69. Stacked unit assembly

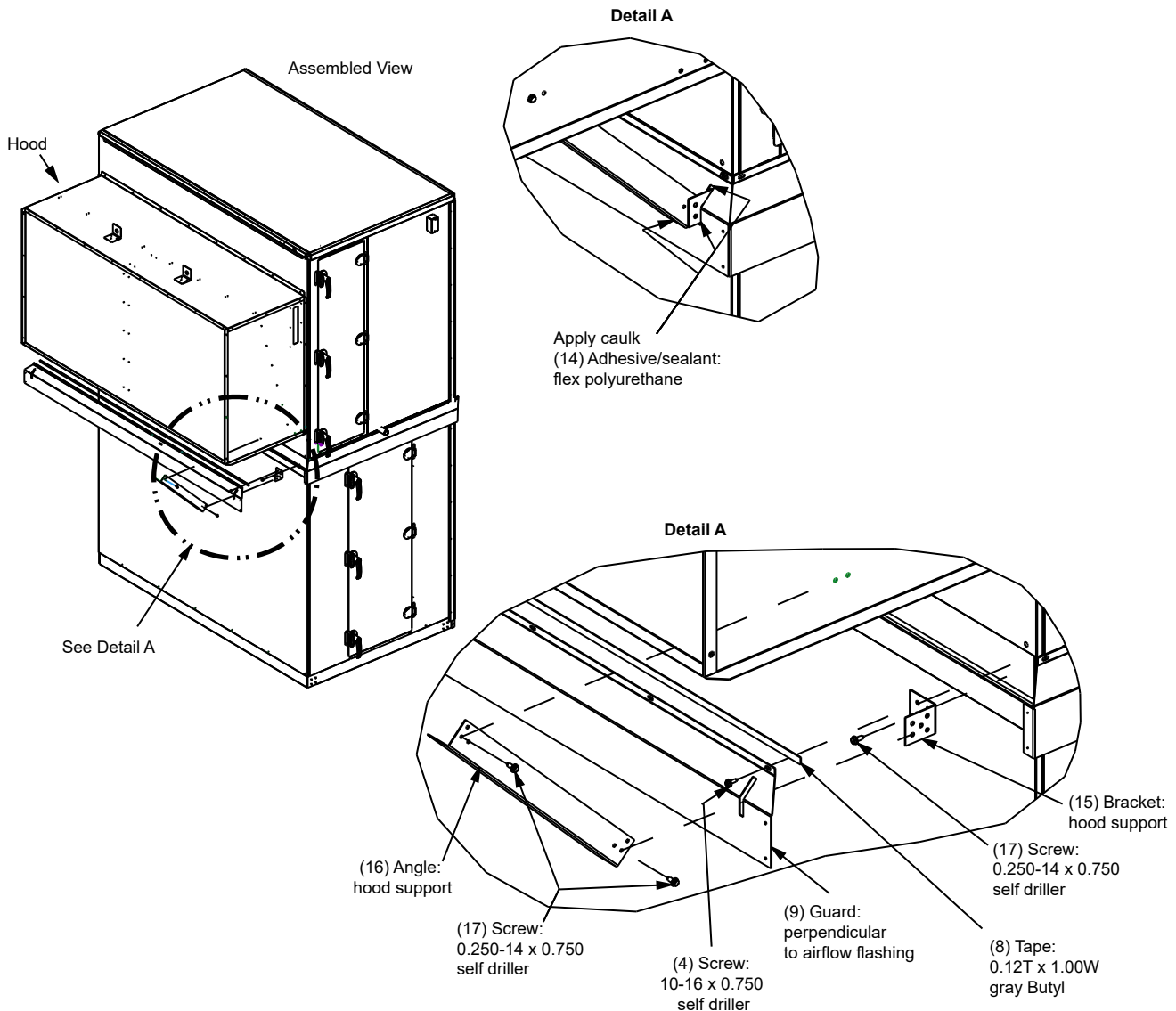

Dual-Path SDU/Winterizer Assembly

A dual-path, split dehumidification unit (SDU)/winterizer air handler consists of two units that are stacked together in a draw-thru arrangement that share one supply fan. The unit on the first level (primary unit) is designed to handle the return air and is larger than the unit on the second level (secondary unit), which is designed to handle outside air.

Factory-designed unit support brackets are provided with all factory-approved, dual-path SDUs or winterizer air handlers.

- A horizontal SDU/winterizer dual-path air handler incorporates a horizontal supply fan on the first level with a top opening in the primary unit that aligns with a bottom opening in the secondary unit.
- A vertical SDU/winterizer dual-path air handler incorporates a vertical supply fan on the second level

with a back opening that aligns with a front opening in the secondary unit.

To assemble air handlers utilizing factory-approved and factory-provided dissimilar unit sizes for horizontal SDU or winterizer applications, join all similar size shipping sections per “Section-to-Section Assembly,” p. 38.

Horizontal SDU/Winterizer Assembly

To assemble dissimilar unit sizes for an indoor horizontal SDU/winterizer configuration:

1. Locate the mounting hardware and gasket material.
 - Note:** Black unit support brackets ship pre-installed on the primary (larger) unit section.
2. Apply gasket in direction of airflow between the black unit support brackets to the roof of the primary unit. See Figure 70, p. 60. The gasket needs to be placed such that it will be directly under the integral base frame of

the secondary (smaller) unit to be stacked on top. The secondary unit will be centered along the width on the primary unit.

Figure 70. Apply gasket in direction of airflow

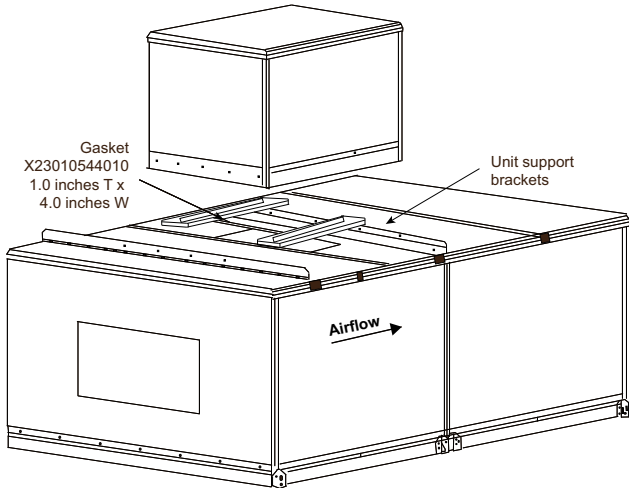

3. If there is an opening in the roof of the primary unit, apply gasket perpendicular to airflow on the roof next to the opening (air entering side only).
4. Lift the secondary unit, following instructions in “General Lifting Considerations,” p. 31 (see Figure 20, p. 33), and place on the black unit support brackets (see Figure 71, p. 60). The secondary unit must be centered on the primary unit between the black unit support brackets.

Figure 71. Place secondary unit on black unit support brackets

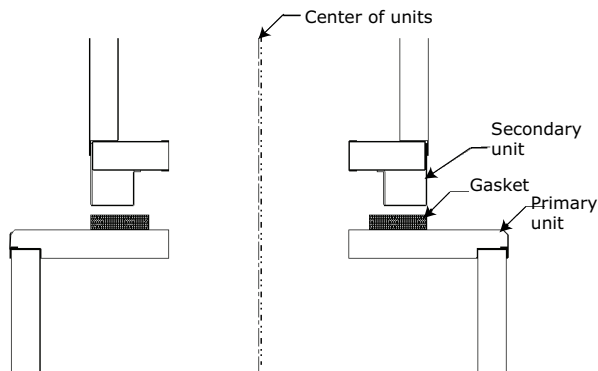

5. Install screws as shown in inserting the appropriate screws using a powered impact gun and taking care not to strip the screws.
6. Remove the secondary unit lifting lugs one at a time and reinstall screws after sections are set in final position.

Figure 72. Install screws using powered impact gun

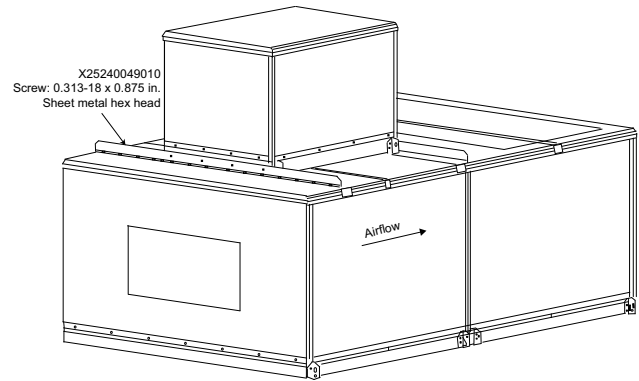

Vertical SDU/Winterizer Assembly

To assemble dissimilar unit sizes for an indoor vertical SDU/winterizer configuration:

1. Apply gasketing to the mating surface of the secondary unit (see Figure 73, p. 60).

Figure 73. Apply gasketing to mating surface of secondary unit

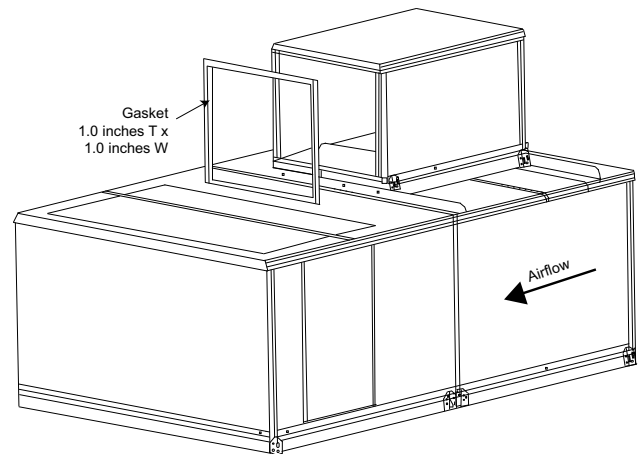

2. Apply gasketing to the mating surface of the primary unit at the bottom of the opening (see Figure 74, p. 61).

Figure 74. Apply gasketing to the mating surface of the primary unit

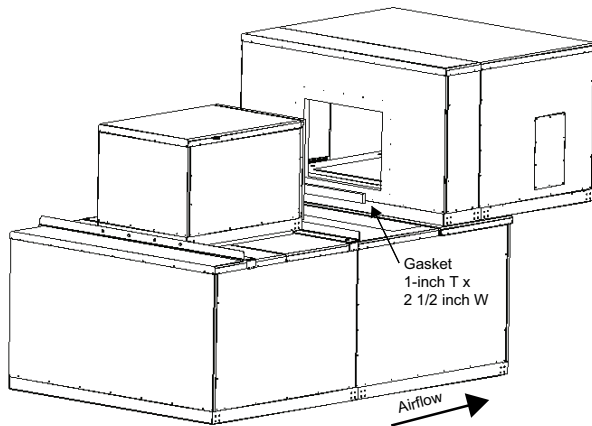

3. Lift the secondary unit, following instructions in “General Lifting Considerations,” p. 31 (see Figure 20, p. 33), and place on the black unit support brackets (see). The secondary unit must be centered on the primary unit between the black unit support brackets.
4. Install trim angles as shown in Figure 75, p. 61 inserting the 10-16 x 3/4-inch self-drilling screws using a powered impact gun and taking care not to strip the screws.

Figure 75. Install trim angles

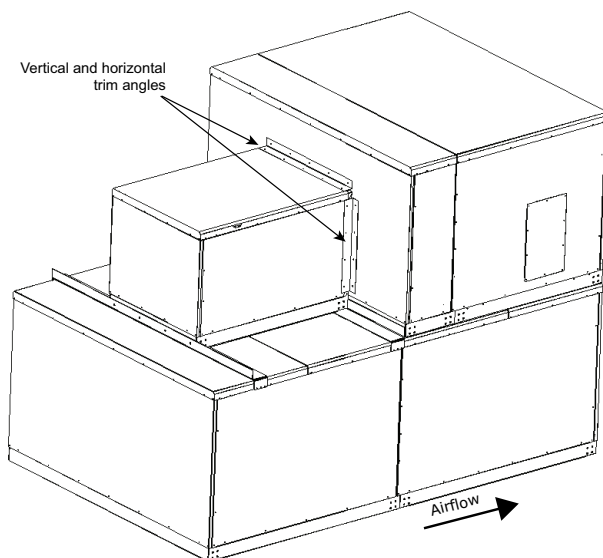

External Raceway Assembly

For air handling units with factory-installed power wiring extending from the first level to the second level, wiring must be connected and assembled in a raceway. See Figure 76, p. 62.

1. Cut zip ties. Remove protective foam cover from connectors.
2. Attach stacked raceway harness connectors, matching connector colors on the high voltage side and connector numbers on the low voltage side.
3. Verify conduit size.
4. Attach covers.
5. Secure conduit. Space tie-downs no greater than 10 inches. Locate cut-screw behind conduit.

Part numbers:

- Indoor
 - External Raceway Kit: KIT09713
- Outdoor
 - External Raceway Kit - Top: KIT16191
 - External Raceway Kit - Bottom: KIT16192

Figure 76. External raceway

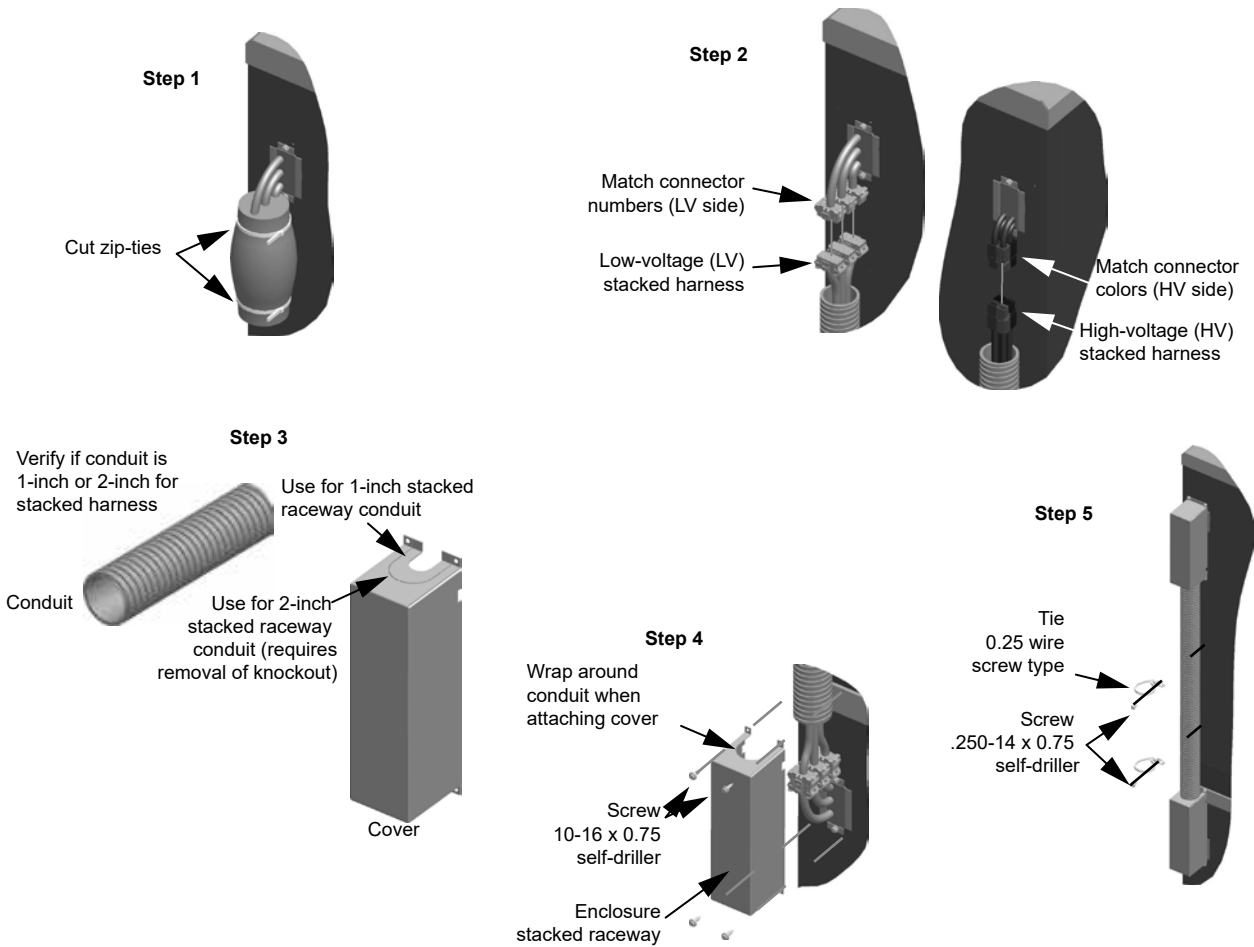

Seismic Application Requirements

Air handling equipment manufactured by Trane is capable of structurally and operationally withstanding the seismic response criteria as required by the International Building Codes (IBC) 2000, 2003, 2006, 2009, 2012, 2015, 2018, 2021, 2024 and CBC 2007, 2010, 2013, 2016, 2019, 2022. Trane has third-party certification for IBC compliance for seismic applications for unit sizes 3-120 and stacked units.

Note: If seismic isolation has been specified, the following requirements must be adhered to for installation. Failure to follow these instructions would void the warranty.

Single Level Design – Size 3 to 120

Grade to Roof Mounted Non-Isolated

See following table.

Steel dunnage/steel curb: 3/8-inch diameter ASTM A325 or SAE grade 5 bolts attached to unit base located as noted above or 1-inch long 3/16-inch welds at unit base located as noted above.

Table 14. Anchor requirements

SDS	lp	z/h	Attachment method	Equipment weight (lbs.)	Seismic Restraint model	Attachment System	
						Qty per tag	Method
1.483	1.5	1.0	Floor mounted (concrete)	45 psf maximum	Bolt down	2 per mounting location	HIT-HY 200+ Rebar A 615 Gr. 60 #5 Embed.: 6.969" Edge: 18" Conc.: 3000 psi 18"
0.967	1.5	1.0	Floor mounted (concrete)	45 psf maximum	Bolt down	2 per mounting location	HIT-HY 200+ Dia: HIT-Z-R 1/2" Embed.: 4.488" Edge: 12" Conc.: 3000 psi 12"
1.850	1.5	1.0	Floor mounted (steel)	45 psf maximum	Bolt down	2 per mounting location	Anchor: A325 Bolt Dia.: 1/2 inch Embed.: n/a Edge: n/a Conc.: n/a
1.850	1.5	1.0	Floor mounted (welded to steel)	45 psf maximum	Welded	1 per mounting location	6-inch weld length with 1/8-inch weld leg

Notes:

1. Install clips at shipping split corners.
2. Install clips at shipping splits containing fans or coils at 48 inches maximum on-center spacing.

Stacked Design – Size 3 to 50
Grade to Roof Mounted ($0 \leq Sds \leq 1.85$) Non-Isolated
4000 psi concrete:

- 5/8 or 3/4-inch diameter Hilti Kwik Bolt TZ carbon steel concrete anchors attached to unit base rails. See [Table 15, p. 63](#).
- Install clips at all ship split corners.
- Install clips at ship splits with a stacked section at 36 inches maximum on-center spacing.

- Install clips at single level ship splits containing fans or coils at 48 inches maximum on-center spacing.
- 3 1/8 or 4 3/4-inch minimum anchor embedment. See [Table 15, p. 63](#).
- 9 or 12-inch minimum distance to the nearest edge. See [Table 15, p. 63](#).
- 9 or 12-inch minimum concrete slab thickness. See [Table 15, p. 63](#).

Steel dunnage/steel curb:

1/2-inch diameter ASTM A325 or SAE Grade 5 bolts attached to unit base located as noted above or 1-inch long 3/16-inch welds at unit bases located as noted above.

Table 15. Anchor requirements for stacked units

SDS	lp	z/h	Attachment Method	Equipment Weight (lbs.)	Seismic Restraint Model	Attachment System	
						Qty per tag	Method
0.421	1.5	1.0	Floor mounted (concrete)	150 psf maximum	Bolt down	See note below	Anchor: HIT-KB TZ CS Dia.: 5/8-in. Embed.: 3.125-inches Edge: 9-in. Conc.: 4000 psi 9-in. thick
0.637	1.5	1.0	Floor mounted (concrete)	150 psf maximum	Bolt down	See note below	Anchor: HIT-KB TZ CS Dia.: 3/4-in. Embed.: 4.75-inches Edge: 12-in. Conc.: 3000 psi 12-in. thick
1.850	1.5	1.0	Floor mounted (steel)	150 psf maximum	Bolt down	See note below	1/2-in. dia. ASTM A325/ Grade 5 bolts

Table 15. Anchor requirements for stacked units (continued)

SDS	lp	z/h	Attachment Method	Equipment Weight (lbs.)	Seismic Restraint Model	Attachment System	
						Qty per tag	Method
1.850	1.5	1.0	Floor mounted (steel)	45 psf maximum	Welded to steel	See note below	1/8-in. thick, 6-in. long weld

Notes:

1. Install anchors at shipping split corners.
2. Install anchors at shipping splits with a stacked module at 36-inches maximum spacing.

Anchoring

Lifting lugs should be used to anchor the unit at the ends of each shipping split. Per the anchor requirements, additional anchoring may be needed. If so, anchors will be provided and installed on the unit. An example of a seismic anchor is shown in Figure 77, p. 64.

Anchor selection meets or exceeds IBC 2000, 2003, 2006, 2009, 2012, 2015, 2018, 2021, 2024 and CBC 2007, 2010, 2013, 2016, 2019, 2022 compliance requirements.

Special Inspection per IBC Section 1704 is required on all installations. All anchors listed above must be installed to meet compliance.

Figure 77. Seismic anchor



Figure 78. Seismic anchor pattern

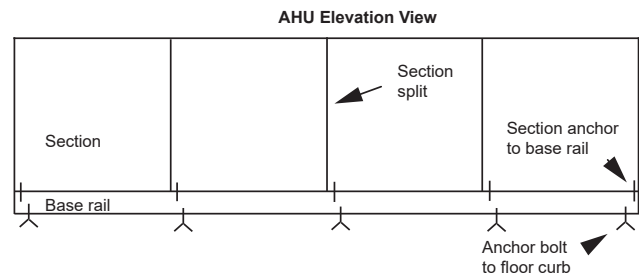
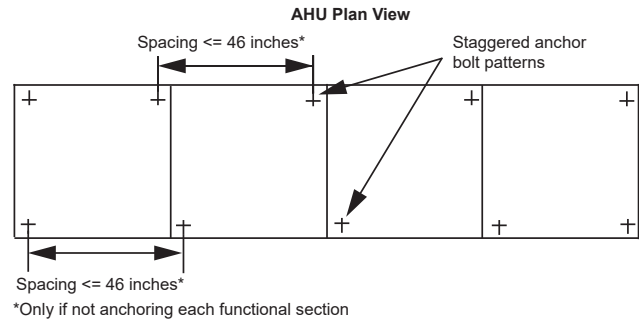

Hurricane Application Requirements

Miami/Dade Co. Hurricane Certification

Performance Climate Changer air handlers are approved and have been designed to comply with the High Velocity Hurricane Zone of the Florida Building Code. Notice of compliance and additional product construction details can be found at the Miami-Dade County, Building Code Compliance Office Web site.

The Florida licensed engineer or architect-of-record for the project shall be responsible for the design, sizing, and structural adequacy of the product framework as well as curbing and attachment to the roof, or as accepted by the corresponding building departments.

Anchoring

The method shown in through is what is approved and recommended for anchoring the unit to substrate and roof curb. Any deviation to this may require the approval of the local building code enforcement agency.

Unit may be installed onto concrete (3.2 ksi min. compressive strength) or 1/4-inch thick steel (36 ksi min. yield) substrates with anchors through lifting lugs and angle

clips attached to first level baserail. Unit may also be installed onto a 36 ksi yield steel curb by others.

Figure 79. Anchoring size 3-35 units to substrate or roof curb for hurricane applications

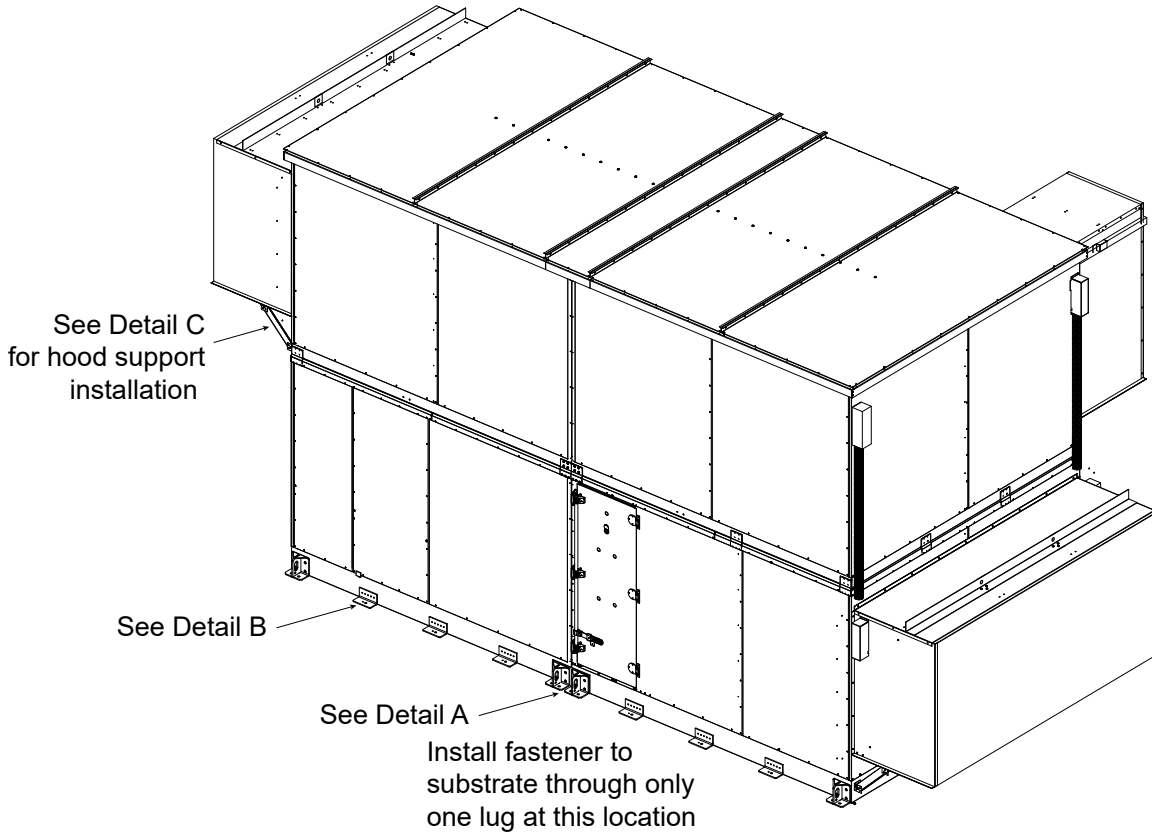

Figure 80. Detail A – typical anchorage at lugs

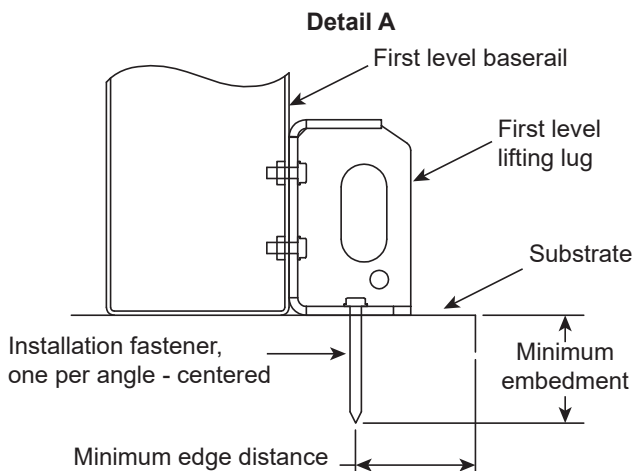

Figure 81. Detail B – typical installation baserail to curb

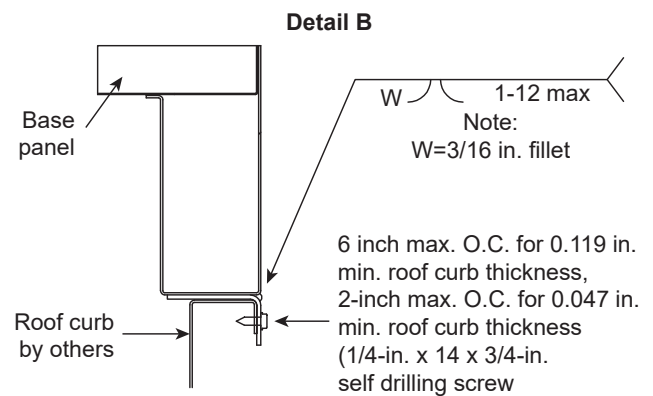

Figure 82. Detail C – typical anchorage at angle clips

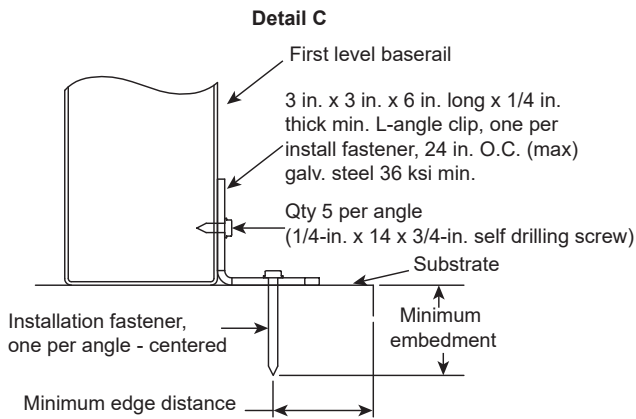

Table 16. Anchorage installation information for hurricane applications

Anchor/substrate	Minimum Embedment	Minimum Edge Distance
1/2-inch powers chem-stud threaded rod installed with chem-stud adhesive capsule in 3.2 ksi minimum concrete substrate	1 1/2-inches	6-inches
1/2-inch HH F-type thread cutting screw installed in 36 ksi minimum steel 1/4-inch thick minimum (full thread engagement)	1/4-inch	1 1/4-inch

Figure 83. Approved field penetrations for hurricane applications

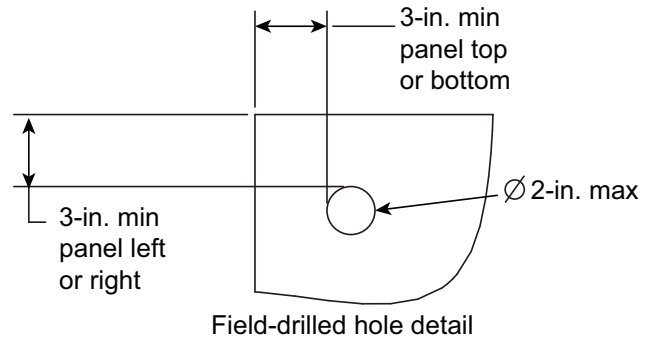

Figure 84. Hood installation size 3-50 - front and back hoods for hurricane applications

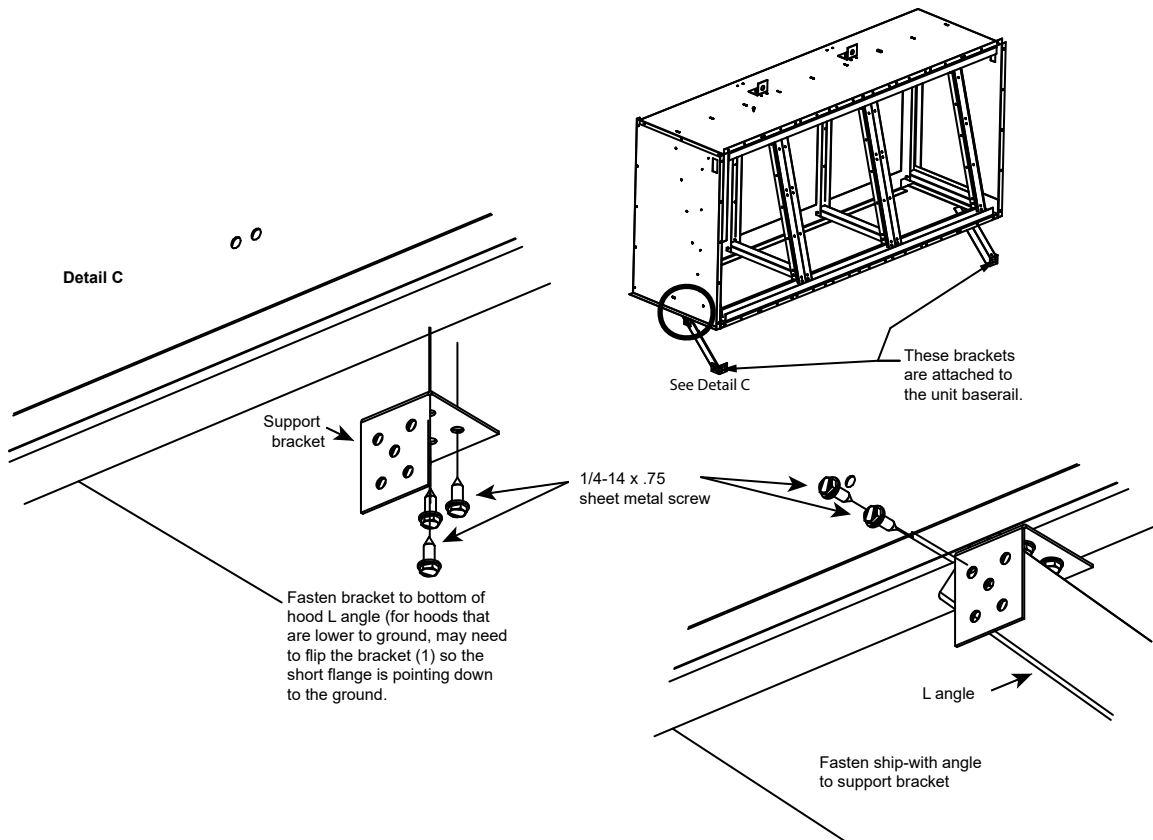
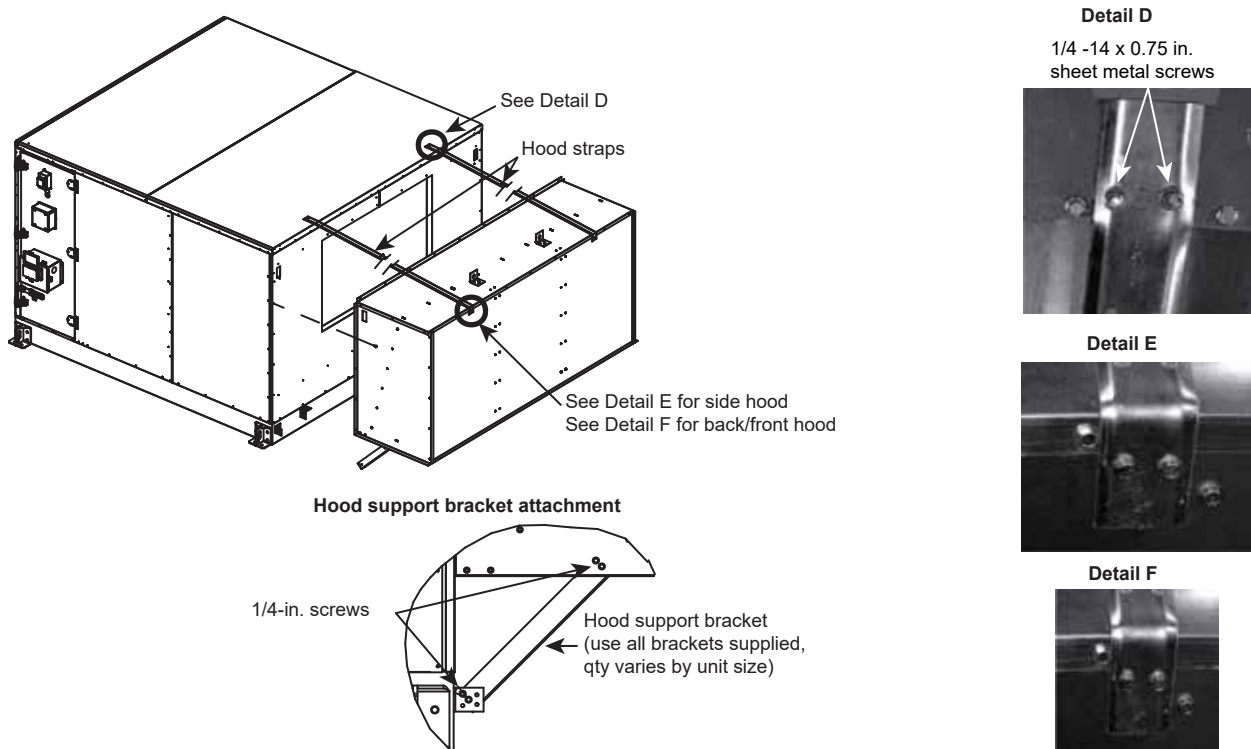
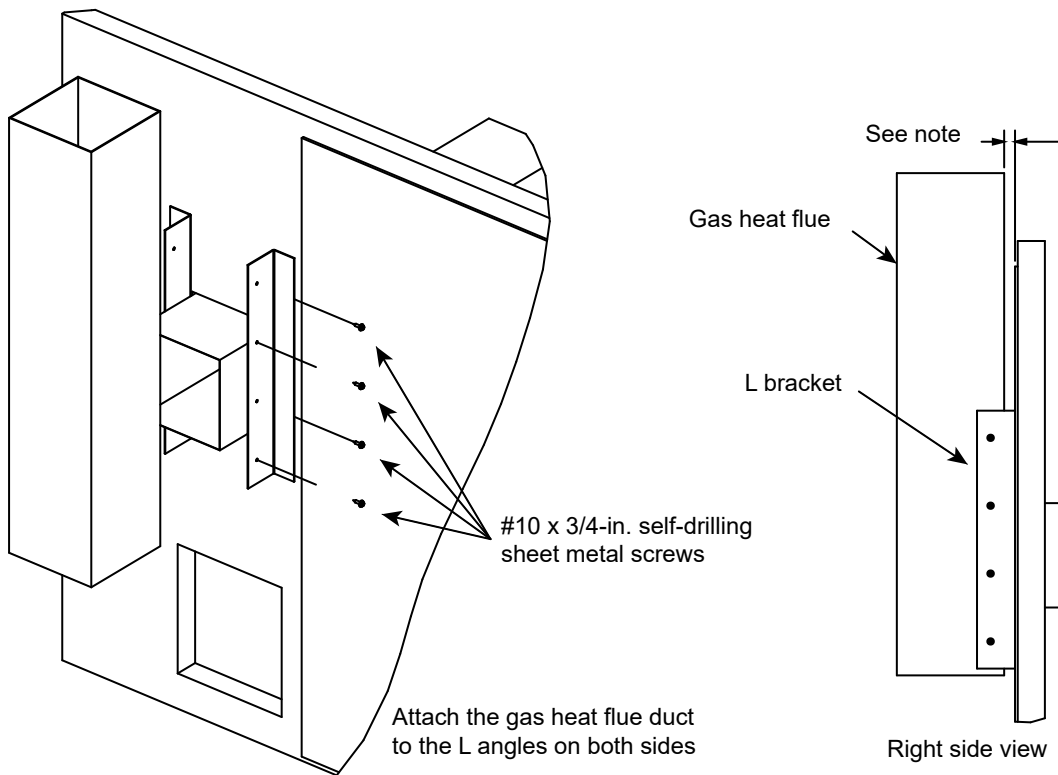

Figure 85. Hood installation size 57 - 120 for hurricane applications



Gas Heat Installation

Figure 86. Gas heat flue installation for hurricane applications



Note:

When installing flue, leave enough clearance to avoid roof's edge and anything above the roof.

Pipe Cabinet Installation

Nested U channels and L angle have to be removed to install the pipe cabinet to the unit and reinstall per hurricane certification guidelines. See [Figure 87, p. 69](#).

1. Remove the fasteners from the top of the nested U channel.
2. Remove the U channel from the unit base L angle and the pipe cabinet base L angle.
3. Remove the corner fasteners from the pipe cabinet base and the unit base L angle. These fasteners are not required to be put back.

Figure 87. Pipe cabinet installation for hurricane applications

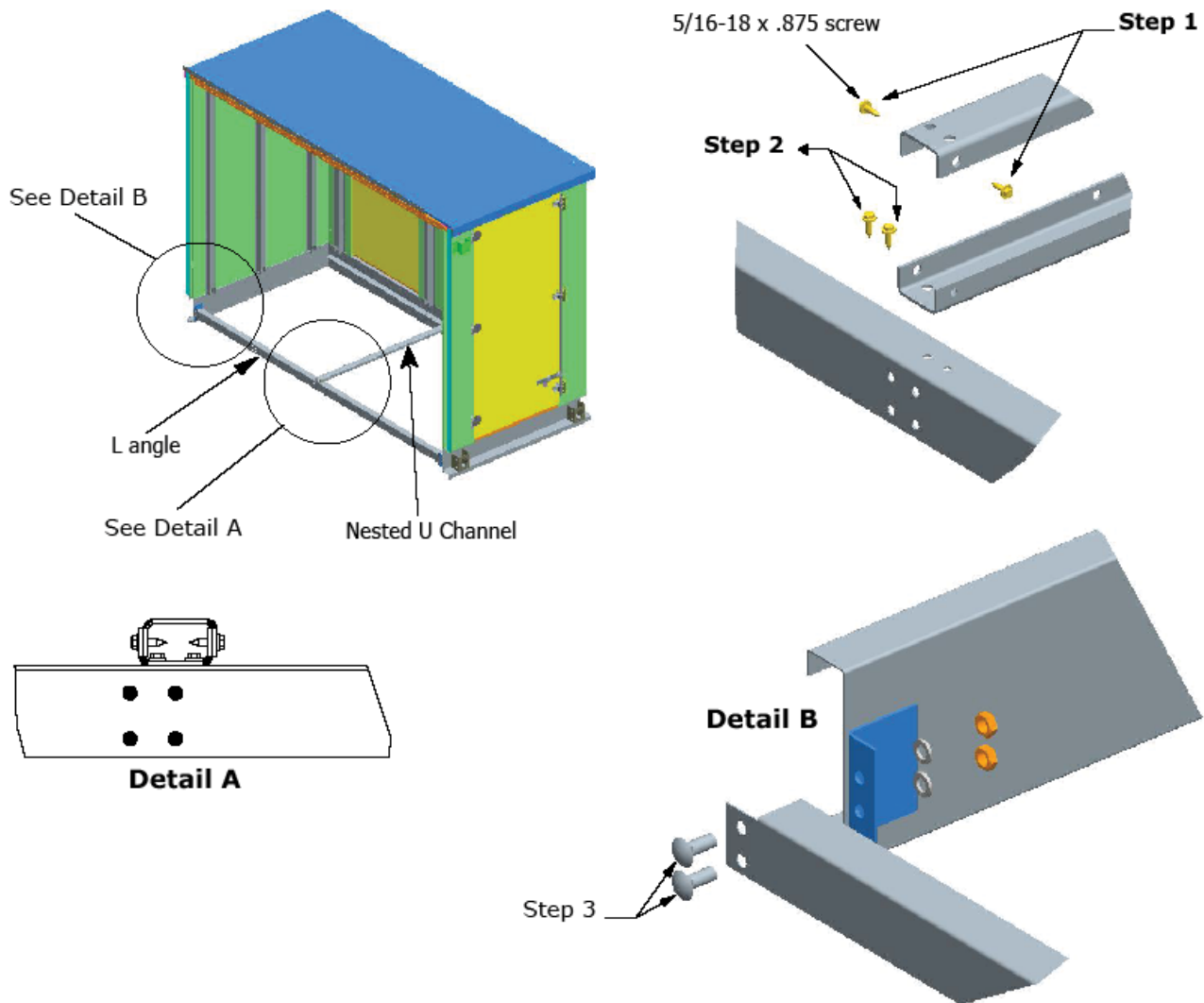

4. Attach the unit base L angle from the pipe cabinet to the unit base rail. See Step 4 in [Figure 88, p. 70](#).
5. Attach a U channel to the unit base L angle. Make sure to clear any coil piping. Make sure to attach enough nested U channels to comply to the unsupported span. See Step 5 in [Figure 88, p. 70](#).
6. Locate the pipe cabinet in place, and reinstall the U channel to the pipe base L angle and reinstall the top U channel to the nest (see Step 1 in [Figure 87, p. 69](#)).
7. When the L angle interferes with the unit base rail lifting lugs or splice plate, mark and cut L angle section to clear the component. If excess L angle is not needed for nested U channel, leave it off. See [Figure 88, p. 70](#).

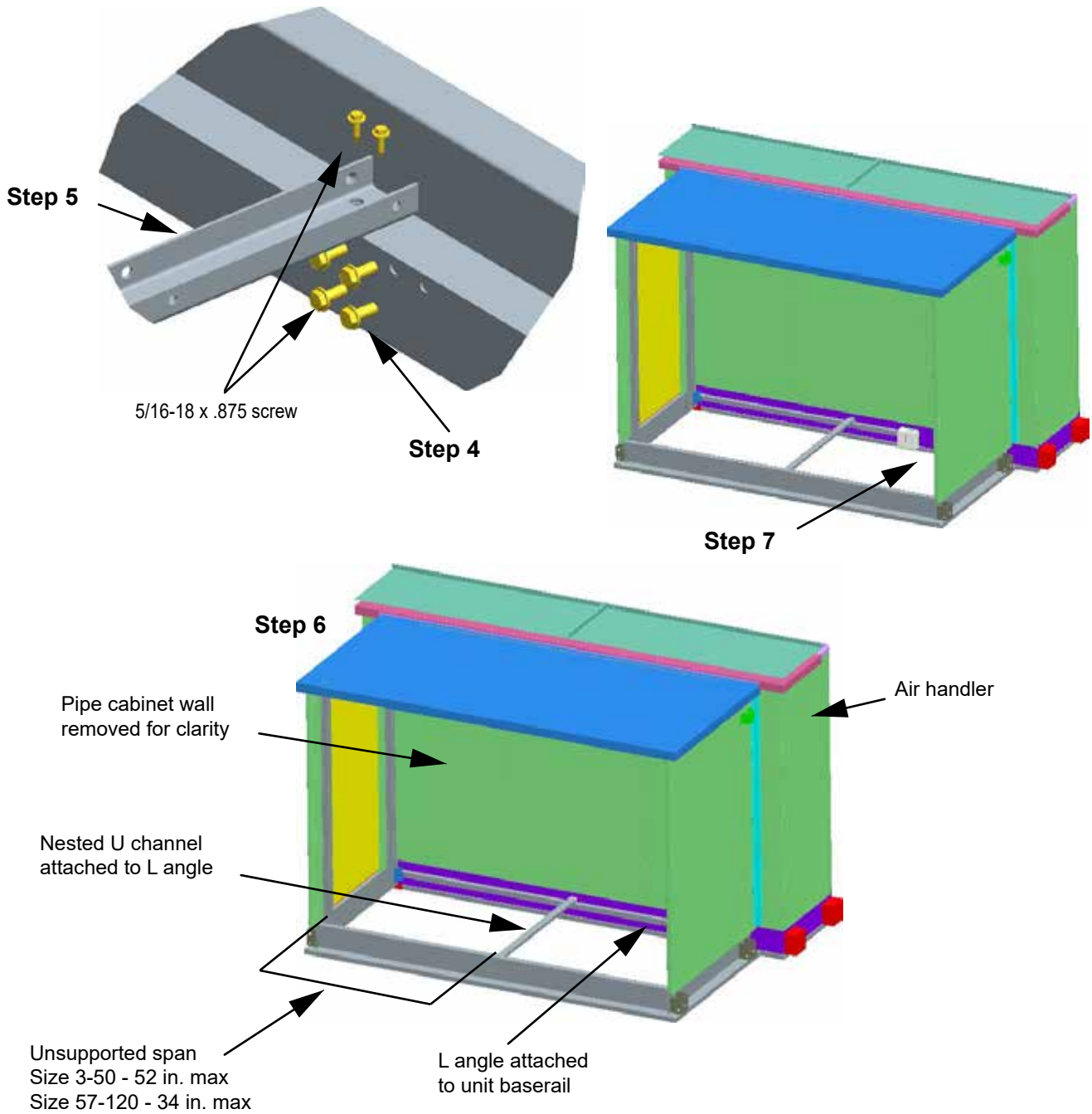
Figure 88. Pipe cabinet installation for hurricane applications

Pipe Cabinet Anchorage

Figure 89. Pipe cabinet anchorage to roof curb details for hurricane applications

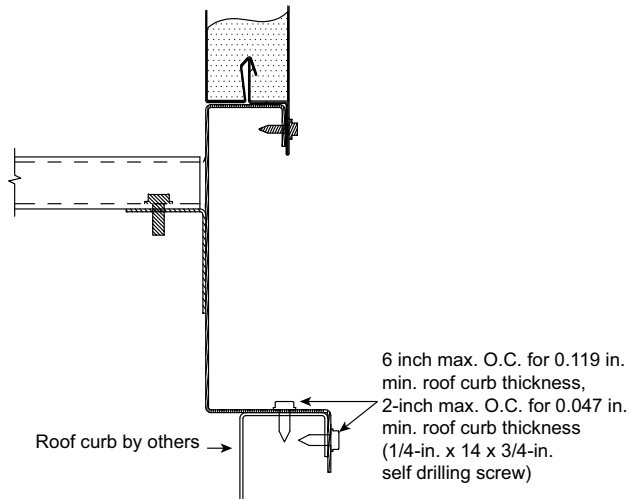
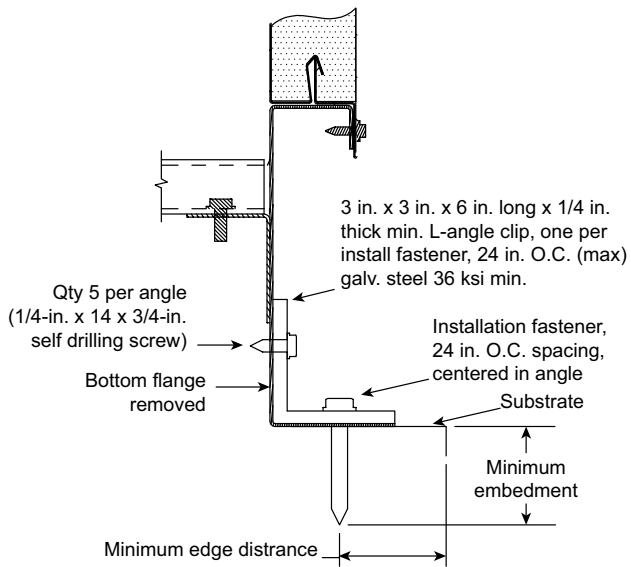

Figure 90. Pipe cabinet direct anchorage to substrate details for hurricane applications





Component Installation

The components in the air handler may have installation requirements that could affect the unit's performance.

Dampers

Dampers are factory-installed and adjusted and can be found in mixing box. There are two damper blade configurations available: parallel-blade and opposed-blade.

Traq™ dampers are another type of damper available in mixing box sections. Traq dampers have only one blade configuration - opposed. They have two control applications available - standard Traq dampers and low-flow Traq dampers. Low-flow Traq dampers are always not linked and consist of two damper sets - one set for minimum outside air measurement and one set for economizing. The single low-flow Traq damper will have a VCM. The economizing damper will not.

The air handler is available with factory-mounted controls or end devices. If the unit is not ordered with controls or

end devices, it is the installer's responsibility to provide and install the damper actuators. Size the actuators according to [Table 17, p. 72](#).

Mixing section dampers are designed for the damper actuators to be direct coupled and installed in the air stream. If other provisions are required, modifications to the section will be the responsibility of the installing contractor.

The economizer that meets or exceeds all mandatory requirements prescribed by Title 24, including but not limited to:

- 5-year parts only warranty
- Successfully tested to 60,000 actuations
- Less than 10 cfm/sq.ft. of damper leakage at one inch w.g. per AMCA 500L

Damper Torque Requirements

Table 17. Mixing box damper torque requirements (inch pound) at 1-inch w.g. air pressure drop

Unit Size	Parallel airfoil damper only	Opposed airfoil damper only	Standard Traq damper only	Low-flow minimum OA Traq damper only	Parallel airfoil damper linked to parallel airfoil damper	Opposed airfoil damper linked to opposed airfoil damper	Standard Traq linked to airfoil damper	Standard Traq linked to standard Traq damper
3	9.00	6.40	18.00	n/a	10.30	7.70	19.30	36.00
4	13.10	9.30	36.00	18.00	14.90	11.20	19.90	72.00
6	17.10	12.20	36.00	18.00	19.60	14.70	38.40	72.00
8	23.30	16.60	54.00	18.00	26.60	19.90	57.30	108.00
10	29.00	20.70	54.00	18.00	33.20	24.90	58.10	108.00
12	35.70	25.50	67.50	22.50	40.70	30.60	72.60	135.00
14	39.50	28.20	67.50	22.50	45.20	33.90	73.10	135.00
17	48.90	34.90	67.50	22.50	55.90	41.90	74.50	135.00
21	60.40	43.10	99.00	33.00	69.00	51.80	107.60	198.00
25	72.40	51.70	99.00	33.00	82.80	62.10	109.30	198.00
30	84.20	60.10	108.00	36.00	96.20	72.20	120.00	216.00
35	100.20	71.50	108.00	36.00	114.50	85.90	122.30	198.00
40	110.20	78.70	108.00	36.00	125.90	94.50	119.60	198.00
50	126.30	90.20	112.50	37.50	144.30	108.20	139.11	216.00
57	154.80	110.60	112.50	37.50	176.90	132.70	167.60	198.00
66	177.60	126.80	150.00	37.50	202.90	152.20	194.70	264.00
80	210.30	150.20	187.50	37.50	240.30	180.20	231.60	360.00
100	272.00	194.30	225.00	37.50	310.90	233.20	297.70	396.00
120	322.40	230.30	225.00	37.50	368.50	276.30	348.10	432.00

Table 18. Air-to-Air plate heat exchanger bypass damper

Unit size	Damper dia (in)		Damper qty	Damper torque (in-lb)	Actuator torque (max) (in-lb)	Actuator qty	Linkage
	A	B					
3	25.00	24.03	1	20.90	42.00	1	No
4	37.50	24.03	1	31.30	42.00	1	No
6	37.50	29.78	1	38.80	180.00	1	No
8	44.00	29.78	1	45.50	180.00	1	No
10	55.00	35.53	1	67.90	180.00	1	No
12	60.00	35.53	1	74.00	180.00	1	No
14	65.50	35.53	1	80.80	180.00	1	No
17	65.50	24.03	2	109.30	180.00	1	Yes
21	73.50	24.03	2	122.70	180.00	1	Yes
25	73.50	29.78	2	152.00	180.00	1	Yes
30	87.00	29.78	2	179.90	180.00	1	Yes
35	93.50	29.78	2	193.40	180.00	2	Yes
40	106.00	29.78	2	219.20	180.00	2	Yes

Table 19. Air-to-Air plate heat exchanger frost damper

Unit size	Damper dia (in)		Damper qty	Damper torque (in-lb)	Actuator torque (max) (in-lb)	Actuator qty	Linkage
	A	B					
3	25.00	13.97	1	12.10	42.00	1	No
4	37.50	13.97	1	18.20	42.00	1	No
6	37.50	13.97	1	18.20	42.00	1	No
8	44.00	13.97	1	21.30	42.00	1	No
10	55.00	13.97	1	26.70	42.00	1	No
12	60.00	13.97	1	29.10	42.00	1	No
14	65.50	13.97	1	31.80	180.00	1	No
17	65.50	13.97	2	63.50	180.00	1	Yes
21	73.50	13.97	2	71.30	180.00	1	Yes
25	73.50	13.97	2	71.30	180.00	1	Yes
30	87.00	13.97	2	84.40	180.00	1	Yes
35	93.50	13.97	2	90.70	180.00	1	Yes
40	106.00	13.97	2	102.80	180.00	1	Yes
50	119.00	13.97	2	115.40	180.00	1	Yes



Component Installation

Table 20. Standard damper to low-flow Traq damper

Unit size	Damper dia (in)	Total damper qty	Low flow Traq damper qty	Linked Traq damper torque (in-lb.)	Damper torque (in-lb.)	Actuator torque (max) (in-lb.)	Actuator qty for linked damper	Actuator qty for linked Traq damper	Actuator qty for single low flow Traq damper	Face-to-face linkage	Linkage on face damper	Actuator total qty
6	13.00	2	1	18.00	17.15	42	1	1	1	No	No	3
8	13.00	3	1	36.00	23.26	42	1	1	1	No	Yes	3
10	13.00	3	1	36.00	29.03	180	1	1	1	No	Yes	3
12	16.00	3	1	45.00	35.65	180	1	1	1	No	Yes	3
14	16.00	3	1	45.00	39.54	180	1	1	1	No	Yes	3
17	16.00	3	1	45.00	48.89	180	1	1	1	No	Yes	3
21	20.00	3	1	66.00	60.39	180	1	1	1	No	Yes	3
25	20.00	3	1	66.00	72.43	180	1	1	1	No	Yes	3
30	24.00	3	1	72.00	84.19	180	1	1	1	No	Yes	3
35	24.00	3	1	72.00	100.16	180	1	1	1	No	Yes	3
40	24.00	3	1	72.00	110.19	180	1	1	1	No	Yes	3
50	28.00	3	1	75.00	126.29	180	1	1	1	No	Yes	3
57	28.00	3	1	75.00	154.80	180	1	1	1	No	Yes	3
66	28.00	4	1	112.50	177.56	180	1	1	1	No	Yes	3
80	28.00	5	2	150.00	210.27	180	2	1	1	No	Yes	4
100	28.00	6	2	187.50	272.04	180	2	2	1	No	Yes	5
120	28.00	6	2	187.50	322.40	180	2	2	1	No	Yes	5

Table 21. Standard Traq damper - low flow Traq damper

Unit size	Damper dia (in)	Damper qty per face	Damper torque (in-lb.)	Std Traq damper torque (in-lb.)	Linked low flow Traq damper torque (in-lb.)	Actuator torque (max) (in-lb.)	Actuator qty for linked Std Traq Damper	Actuator qty for linked low flow Traq damper	Actuator qty for single low flow Traq damper	Face-to-face linkage	Linkage on face	Total actuator qty
6	13.00	2	18.0	36.0	18.00	42	1	-	2	No	Yes	3
8	13.00	3	18.0	54.0	36.00	180	1	1	1	No	Yes	3
10	13.00	3	18.0	54.0	36.00	180	1	1	1	No	Yes	3
12	16.00	3	22.5	67.5	45.00	180	1	1	1	No	Yes	3
14	16.00	3	22.5	67.5	45.00	180	1	1	1	No	Yes	3
17	16.00	3	22.5	67.5	45.00	180	1	1	1	No	Yes	3
21	20.00	3	33.0	99.0	66.00	180	1	1	1	No	Yes	3
25	20.00	3	33.0	99.0	66.00	180	1	1	1	No	Yes	3
30	24.00	3	36.0	108.0	72.00	180	1	1	1	No	Yes	3
35	24.00	3	36.0	108.0	72.00	180	1	1	1	No	Yes	3
40	24.00	3	36.0	108.0	72.00	180	1	1	1	No	Yes	3

Table 21. Standard Traq damper - low flow Traq damper (continued)

Unit size	Damper dia (in)	Damper qty per face	Damper torque (in-lb.)	Std Traq damper torque (in-lb.)	Linked low flow Traq damper torque (in-lb.)	Actuator torque (max) (in-lb.)	Actuator qty for linked Std Traq Damper	Actuator qty for linked low flow Traq damper	Actuator qty for single low flow Traq damper	Face-to-face linkage	Linkage on face	Total actuator qty
50	28.00	3	37.5	112.5	75.00	180	1	1	1	No	Yes	3
57	28.00	3	37.5	112.5	75.00	180	1	1	1	No	Yes	3
66	28.00	4	37.5	150.0	112.50	180	1	1	1	No	Yes	3
80	28.00	5	37.5	187.5	150.00	180	2	1	1	No	Yes	4
100	28.00	6	37.5	225.0	187.5	180	2	2	1	No	Yes	5
120	28.00	6	37.5	225.0	187.5	180	2	2	1	No	Yes	5

Table 22. Side Traq damper - standard flow mixing box

Unit size	Damper dia (in)	Damper qty	Damper torque (in-lb)	Total torque (in-lb)	Actuator torque (max) (in-lb)	Actuator qty	Face-to-face linkage	Linkage on face
3, 4, 6, 8	13.00	1	18.00	18.00	42.00	1	No	No
10, 12	16.00	1	22.50	22.50	42.00	1	No	No
14, 17	13.00	2	18.00	36.00	42.00	1	No	Yes
21, 25	16.00	2	22.50	45.00	180.00	1	No	Yes
30, 35, 40	20.00	2	33.00	66.00	180.00	1	No	Yes
50, 57, 66	24.00	2	36.00	72.00	180.00	1	No	Yes
80	28.00	2	37.50	75.00	180.00	1	No	Yes
100	28.00	3	37.50	112.50	180.00	1	No	Yes
120	24.00	4	36.00	144.00	180.00	1	No	Yes

Table 23. Single-Side Traq low flow mixing box

Unit size	Damper Dia (in)	Damper Qty	Damper Torque (in-lb.)	Low flow Traq Torque (in-lb.)	Remained Traq Torque (in-lb.)	Actuator qty for low flow Traq	Actuator qty for remained damper	Actuator total Qty	Face-to-face Linkage	Linkage on Face
14, 17	13.00	2	18.00	18.00	18.00	1	1	2	No	No
21, 25	16.00	2	22.50	22.50	22.50	1	1	2	No	No
30, 35, 40	20.00	2	33.00	33.00	33.00	1	1	2	No	No
50, 57, 66	24.00	2	36.00	36.00	36.00	1	1	2	No	No
80	28.00	2	37.50	37.50	37.50	1	1	2	No	No
100	28.00	3	37.50	37.50	75.00	1	1	2	No	Yes
120	24.00	4	36.00	36.00	108.00	1	1	2	No	Yes



Component Installation

Table 24. Dual-side Traq low flow mixing box

Unit size	Damper dia (in)	Damper qty	Damper torque (in-lb)	Low-flow Traq torque (in-lb)	Re-mained Traq torque (in-lb)	Actuator qty for std Traq damper	Actuator qty for low-flow Traq damper	Actuator qty for single low-flow Traq	Actuator total qty	Face-to-face linkage	Linkage on face
3, 4, 6, 8	13.00	2	18.00	18.00	18.00	1	-	1	2	No	No
10, 12	16.00	2	22.50	22.50	22.50	1	-	1	2	No	No
14, 17	13.00	4	18.00	18.00	54.00	1	1	1	3	No	No
21, 25	16.00	4	22.50	22.50	67.50	1	1	1	3	No	No
30, 35, 40	20.00	4	33.00	33.00	99.00	1	1	1	3	No	No
50, 57, 66	24.00	4	36.00	36.00	108.00	1	1	1	3	No	No
80	28.00	4	37.50	37.50	112.50	1	1	1	3	No	No
100	28.00	6	37.50	37.50	187.50	1	1	1	3	No	Yes
120	24.00	8	36.00	36.00	252.00	1	1	1	3	No	Yes

Table 25. Side rectangle angle damper - 2000 fpm

Unit size	A (in)	B (in)	Damper qty	Torque (in-lb.)	Actuator torque (max) (in-lb.)	Actuator qty	Linkage
3	11.25	13.97	1	13.10	42.00	1	No
4	11.25	13.97	1	13.10	42.00	1	No
6	15.75	13.97	1	18.30	42.00	1	No
8	20.25	13.97	1	23.60	42.00	1	No
10	20.25	16.30	1	27.50	42.00	1	No
12	27.00	16.30	1	36.70	42.00	1	No
14	23.25	19.72	1	38.20	42.00	1	No
17	30.50	19.72	1	50.10	180.00	1	No
21	36.75	19.72	1	60.40	180.00	1	No
25	45.75	19.72	1	75.20	180.00	1	No
30	48.50	20.22	1	81.70	180.00	1	No
35	45.50	25.47	1	96.60	180.00	1	No
40	48.00	28.35	1	113.40	180.00	1	No
50	56.75	31.22	1	147.60	180.00	1	No
57	65.75	31.22	1	171.10	180.00	1	No
66	70.50	31.22	1	183.40	180.00	2	No
80	85.00	31.22	1	221.10	180.00	2	No
100	95.00	36.97	1	292.70	180.00	2	No
120	96.00	42.72	1	341.80	180.00	2	No

Table 26. Short mixing box rectangle damper - top, back or bottom only

Unit size	A (in)	B (in)	Damper Qty	Torque (in-lb.)	Actuator Torque (max) (in-lb.)	Actuator qty	Linkage
3	13.00	8.22	1	5.20	42.00	1	No
4	19.75	8.22	1	7.90	42.00	1	No
6	27.00	8.22	1	10.80	42.00	1	No
8	35.00	8.22	1	14.00	42.00	1	No
10	43.75	8.22	1	17.50	180.00	1	No
12	32.00	13.97	1	21.70	180.00	1	No
14	60.00	8.22	1	24.00	180.00	1	No
17	43.50	13.97	1	29.50	180.00	1	No
21	53.75	13.97	1	36.50	180.00	1	No
25	64.50	13.97	1	43.80	180.00	1	No
30	55.00	19.72	1	52.70	180.00	1	No
35	64.00	19.72	1	61.40	180.00	1	No
40	56.50	25.47	1	70.00	180.00	1	No
50	68.00	25.47	1	84.20	180.00	1	No
57	66.00	31.22	1	100.20	180.00	1	No
66	58.50	19.72	2	112.20	180.00	1	No
80	54.25	25.47	2	134.30	180.00	1	No
100	65.25	25.47	2	161.60	180.00	1	No
120	66.00	31.22	2	200.30	180.00	2	No

Table 27. Damper torque

Unit Size	E-Wheel (cfm)	CDQ(cfm)	A(in)	B(in)	Damper qty	Torque (in-lb)	Actuator Torque (max) (in-lb)	Actuator Qty	Linkage
3-4		1000	18.00	8.22	1	5.10	42.00	1	No
4		1500							
4-6	900	2000							
	1500								
4-8	2200		32.00	8.22	1	9.10	42.00	1	No
8	1500	3000							
10-12	2200								
8-14	3000		41.75	8.22	1	11.90	42.00	1	No
14	2200								
10-17	4000								
10	5000	4000							
		5000							



Component Installation

Table 27. Damper torque (continued)

Unit Size	E-Wheel (cfm)	CDQ(cfm)	A(in)	B(in)	Damper qty	Torque (in-lb)	Actuator Torque (max) (in-lb)	Actuator Qty	Linkage
17-21	3000		53.50	8.22	1	15.30	42.00	1	No
12		5000							
12-21	5000								
12-14	6000	6000							
14	7000	7000							
21-30	4000		52.50	13.97	1	25.50	180.00	1	No
25-40	5000								
	6000								
35-40	7000								
21-25		10500							
30-50	10500								
17-21	6000		61.50	8.22	1	17.60	42.00	1	No
17	7000	7000							
21-30	7000		66.00	8.22	1	18.80	42.00	1	No
50	7000		65.00	13.97	1	31.50	180.00	1	No
25-50	8500								
30-50	12500								
30		13000							
21	8500	8500	70.00	8.22	1	20.00	42.00	1	No
35		15000	84.50	13.97	1	41.00	180.00	1	No
		17500							
35-50	17500								
35-50	15000		75.00	13.97	1	36.40	180.00	1	No
40		17500	102.00	13.97	1	49.50	180.00	1	No
		20000							
40-50	20000								
50	25000	20000	113.00	13.97	1	54.80	180.00	1	No
		25000							

Table 28. Energy recovery bypass opposed-blade damper

Unit size	A (in)	B (in)	Damper qty	Torque (in-lb.)	Actuator Torque (max) (in-lb.)	Actuator qty	Linkage
3 - 8	18.00	8.22	1	5.10	42.00	1	No
8 - 14	32.00	8.22	1	9.10	42.00	1	No
10 - 17	41.75	8.22	1	11.90	42.00	1	No
12 - 21	53.50	8.22	1	15.30	42.00	1	No
21 - 50	52.50	13.97	1	25.50	180.00	1	No
17, 21	61.50	8.22	1	17.60	42.00	1	No

Table 28. Energy recovery bypass opposed-blade damper (continued)

Unit size	A (in)	B (in)	Damper qty	Torque (in-lb.)	Actuator Torque (max) (in-lb.)	Actuator qty	Linkage
21 - 30	66.00	8.22	1	18.80	42.00	1	No
25 - 50	65.00	13.97	1	31.50	180.00	1	No
21	70.00	8.22	1	20.00	42.00	1	No
35 - 50	84.50	13.97	1	41.00	180.00	1	No
35 - 50	75.00	13.97	1	36.40	180.00	1	No
40 - 50	102.00	13.97	1	49.50	180.00	1	No
50	113.00	13.97	1	54.80	180.00	1	No

Table 29. Exhaust fan damper torque

Unit size	A (in)	B (in)	Damper Qty	Torque (in-lb.)	Actuator Torque (max) (in-lb.)	Actuator qty	Linkage
3	19.83	13.97	1	13.50	42.00	1	No
4	32.33	13.97	1	22.00	42.00	1	No
6	32.33	13.97	1	22.00	42.00	1	No
8	38.83	13.97	1	26.40	180.00	1	No
10	49.83	13.97	1	33.80	180.00	1	No
12	54.83	13.97	1	37.20	180.00	1	No
14	60.33	13.97	1	41.00	180.00	1	No
17	60.33	13.97	1	41.00	180.00	1	No
21	68.33	13.97	1	46.40	180.00	1	No
25	68.33	13.97	1	46.40	180.00	1	No
30	81.83	13.97	1	55.60	180.00	1	No
35	40.88	19.72	2	78.40	180.00	2	No
40	30.42	19.72	3	87.50	180.00	3	No
50	34.75	19.72	3	99.90	180.00	3	No
57	34.75	19.72	3	99.90	180.00	3	No
66	39.75	31.22	3	181.00	180.00	3	No
80	38.42	31.22	3	174.90	180.00	3	No
100	43.09	31.22	3	196.20	180.00	3	No
120	52.25	31.22	3	237.90	180.00	3	No

Table 30. Energy recovery recirculation parallel-blade damper

Unit size	A (in)	B (in)	Damper qty	Torque (in-lb.)	Actuator torque (max) (in-lb.)	Actuator qty	Linkage
3	16.00	13.97	1	10.90	42.00	1	No
4	28.50	13.97	1	19.40	42.00	1	No
6	28.50	13.97	1	19.40	42.00	1	No
8	35.00	13.97	1	23.80	42.00	1	No



Component Installation

Table 30. Energy recovery recirculation parallel-blade damper (continued)

Unit size	A (in)	B (in)	Damper qty	Torque (in-lb.)	Actuator torque (max) (in-lb.)	Actuator qty	Linkage
10	46.00	13.97	1	31.20	42.00	1	No
12	51.00	13.97	1	34.60	42.00	1	No
14	56.50	13.97	1	38.40	180.00	1	No
17	56.50	13.97	1	38.40	180.00	1	No
21	64.50	13.97	1	43.80	180.00	1	No
25	64.50	13.97	1	43.80	180.00	1	No
30	78.00	13.97	1	53.00	180.00	1	No
35	84.50	13.97	1	57.40	180.00	1	No
40	97.00	13.97	1	65.90	180.00	1	No
50	110.00	13.97	1	74.70	180.00	1	No

Table 31. Internal face-and-bypass damper torque requirements

Unit size	A (in)	B (in)	Damper Qty	Torque (in-lb)	Actuator torque (max) (in-lb.)	Actuator Qty
3	23.20	18.31	1	12.80	42.00	1
4	35.70	18.31	1	19.70	42.00	1
6	35.70	19.37	1	20.90	42.00	1
8	42.20	24.39	1	31.10	42.00	1
10	53.20	24.39	1	39.20	42.00	1
12	58.20	31.14	1	54.80	180.00	1
14	63.70	31.14	1	59.90	180.00	1
17	63.70	36.61	1	70.50	180.00	1
21	71.70	42.17	1	91.30	180.00	1
25	71.70	47.80	1	103.50	180.00	1
30	85.20	47.80	1	123.00	180.00	1
35	43.44	50.94	2	133.70	180.00	1
40	32.19	50.94	3	148.60	180.00	1
50	36.52	62.44	3	206.70	180.00	2
57	36.52	68.19	3	225.70	180.00	2
66	41.52	73.94	3	278.20	180.00	2
80	41.52	85.44	3	321.50	180.00	2
100	46.19	99.41	3	416.10	180.00	3
120	55.35	99.41	3	498.70	180.00	3

Opposed-Blade/Parallel-Blade Damper

Opposed-blade and parallel-blade airfoil dampers in unit sizes 3-120, as well as internal and external face-and-bypass sections, have centered dampers with an internal jack-shaft (see Figure 89 and Figure 90). A 95-degree actuator rotation gives a 90-degree blade travel.

Note: Damper blades should be checked for proper operation from full open to full closed position before unit start up. Damper blade positioning may have changed due to shipping and handling vibrations.

Figure 91. Typical mixing box configurations for unit sizes 3 to 120

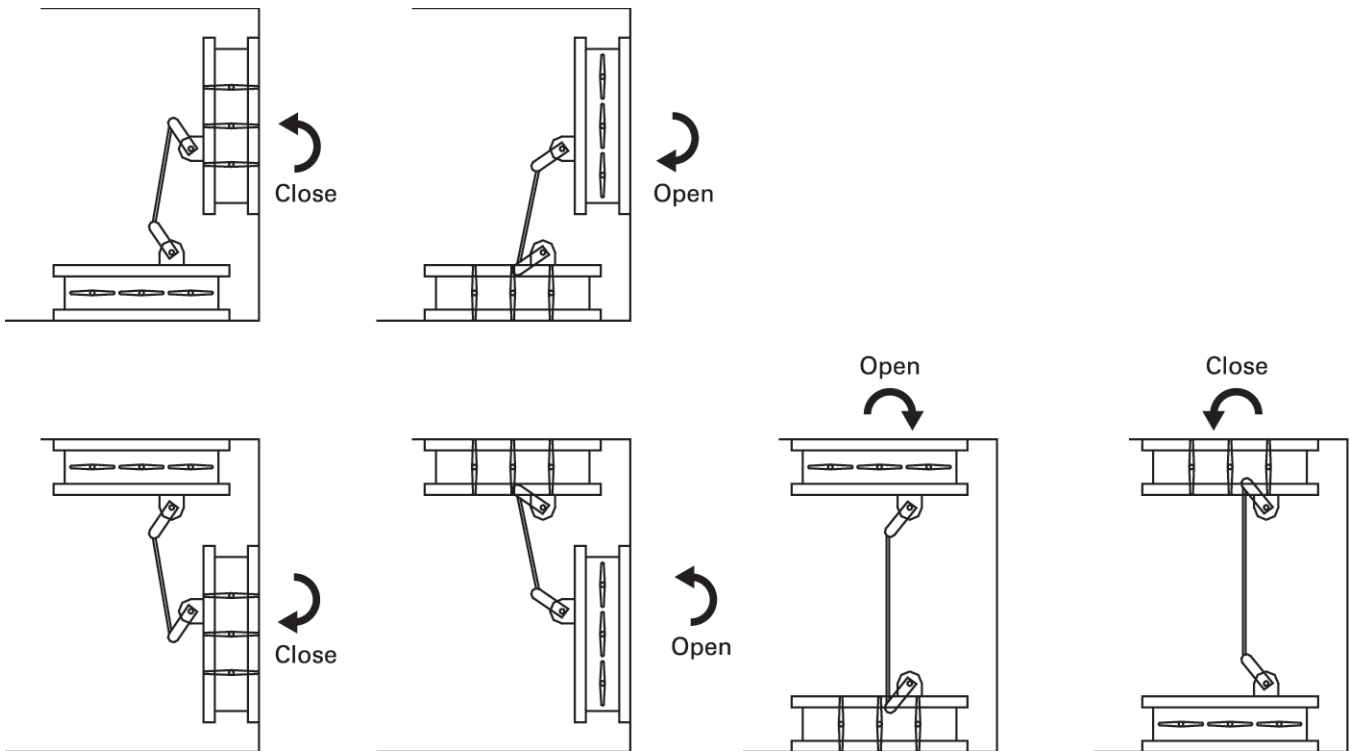

Figure 92. Typical external face-and-bypass configuration

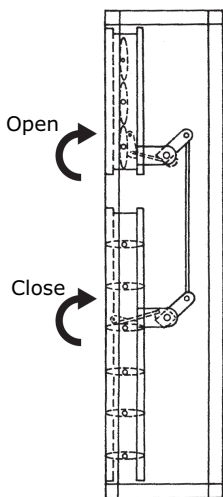
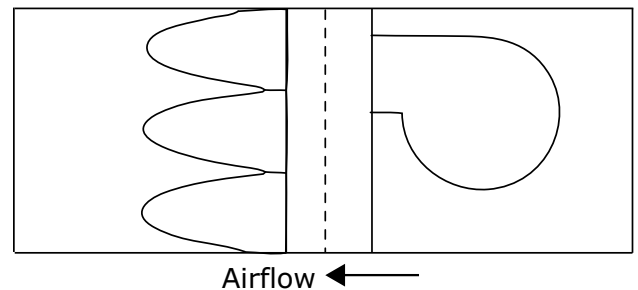

Figure 93. Diffuser placement sizes 3 to 120



Fans

The fan section can be configured as either draw-thru or blowthru. Review the submittals and unit tagging information prior to assembly to determine placement.

Diffusers

Diffuser sections are usually placed between a fan and a downstream coil or filter. Because placement is critical to unit performance, verify the correct placement of the diffuser section before assembling the unit.

⚠ WARNING

Hazardous Service Procedures!

Failure to follow all precautions in this manual and on the tags, stickers, and labels could result in death or serious injury.

Technicians, in order to protect themselves from potential electrical, mechanical, and chemical hazards, **MUST** follow precautions in this manual and on the tags, stickers, and labels, as well as the following instructions: Unless specified otherwise, disconnect all electrical power including remote disconnect and discharge all energy storing devices such as capacitors before servicing. Follow proper lockout/tagout procedures to ensure the power can not be inadvertently energized. When necessary to work with live electrical components, have a qualified licensed electrician or other individual who has been trained in handling live electrical components perform these tasks.

Fan Isolation

The fan-and-motor assembly is internally isolated. The fan and motor bases are bolted to a minimum of four spring isolators. The isolators are secured to the fan section support base.

Shipping tie-down bolts are bolted adjacent to the isolators between the fan isolation base and the isolator support frame. The shipping tie-downs secure the isolation base to the support assembly to prevent any damage to the fan section during shipment.

Note: Remove the tie-downs **only** if the factory-provided isolation is to be used.

Adjusting the Isolators

Once the shipping tie-downs are removed and the internal isolation is released, it may be necessary to adjust the isolators to achieve the proper operation height of the fan and motor isolation base.

Minimum required clearances are listed in [Table 32, p. 82](#). To determine the isolator clearances on all unit sizes, measure between the top of the cabinet channel and the bottom of the isolation base channel.

Table 32. Minimum isolator clearances (inches)

Unit Size	Fan Type	Required Clearance
3-8	Plenum	1.0
10-30	Plenum	0.5
35-57	Plenum	0.5
66-120	Plenum	1.0

Figure 94. Isolator adjustment for unit sizes 3-8

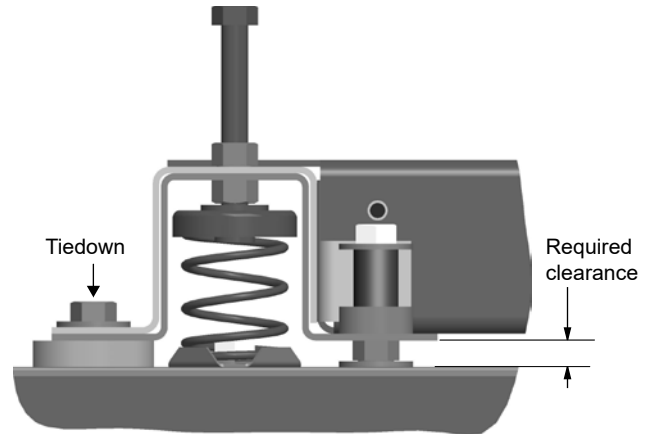

Figure 95. Isolator adjustment for unit sizes 10-30

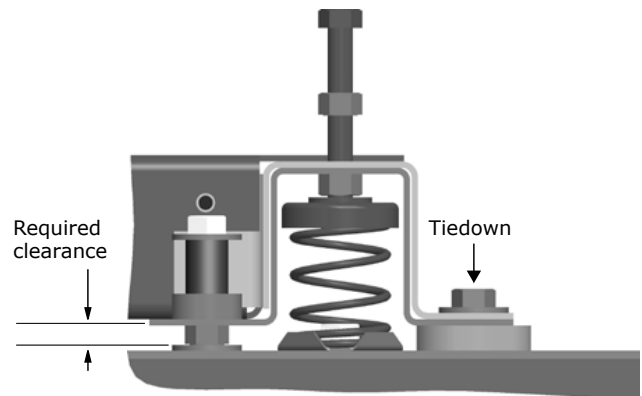

Figure 96. Isolator adjustment for unit sizes 66-120

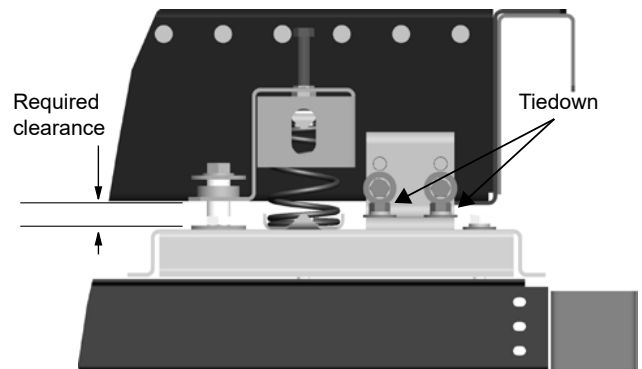
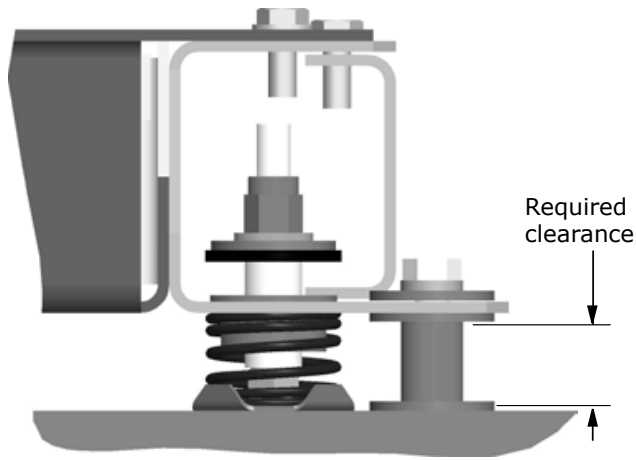

Figure 97. Isolator adjustment for belt-drive plenum fans for unit sizes 3-8



Filters

Bag and cartridge filter sections can be used as a pre-filter section, a final filter section, or both. This use is determined by the filter's placement in relation to the fan.

- A final filter is placed after the fan.
- A pre-filter is placed before the fan.

Note: Cartridge and bag filters provided by Trane are fitted with a 7/8-inch header that fits in the filter track. If using filters supplied by another manufacturer, filters should be purchased with a 7/8-inch header. In some cases it may be necessary to gasket other manufacturers' filters to ensure a good air seal.

Filters should be installed when the unit is set. This will protect internal components, such as the heating and cooling coils.

Final Filter Section

A final filter section should not be bolted directly to the face of a fan section. One or more intermediate sections must be placed between the fan discharge and the filter section.

Pre-Filter Section

A pre-filter section has no special installation requirements unless placed directly upstream of a plenum fan. In these configurations, ensure a blank section is placed between the fan inlet and the filter section.

Trane recommends the use of disposable pre-filters with high-efficiency filters. Disposable pre-filters slide into the mounting tracks just ahead of the bag/cartridge filters.

Filter Installation

⚠ WARNING

Hazardous Voltage!

Failure to disconnect power before servicing could result in death or serious injury.

Disconnect all electric power, including remote disconnects before servicing. Follow proper lockout/tagout procedures to ensure the power can not be inadvertently energized. Verify that no power is present with a voltmeter.

To install filters:

1. Disconnect the power to the unit.
2. Open the filter section access door.
3. Slide the filters into the tracks.

Note: Bag filters must be installed with the pleats in the vertical plane.

4. The block-off is permanently installed and will create a seal when the access door is closed.
5. Close the access door slowly to allow any gasketing to compress.

Figure 98. Filter block-off placement

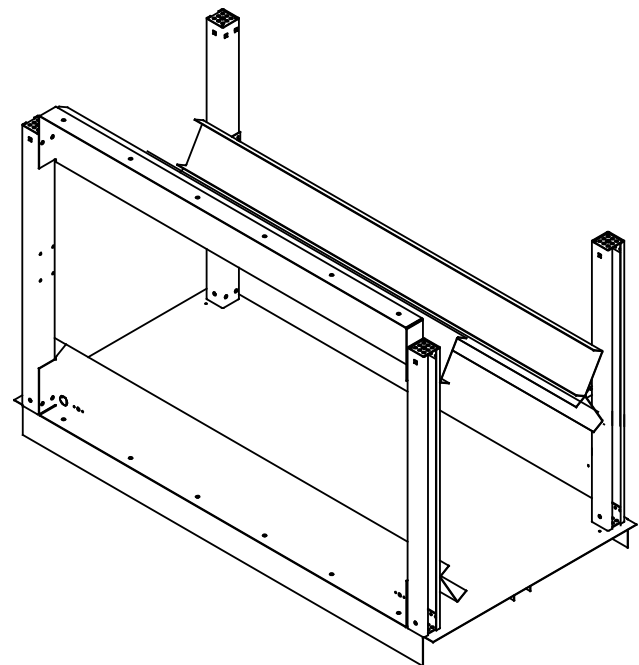

Filter Placement
Figure 99. Side-loading 2-inch and 4-inch flat filter placement for unit sizes 3-35

Figure 100. Side-loading 2-inch and 4-inch flat filter placement for unit sizes 40-120



Component Installation

Figure 101. Side-loading 2-inch/4-inch combination flat filter placement for unit sizes 3-35

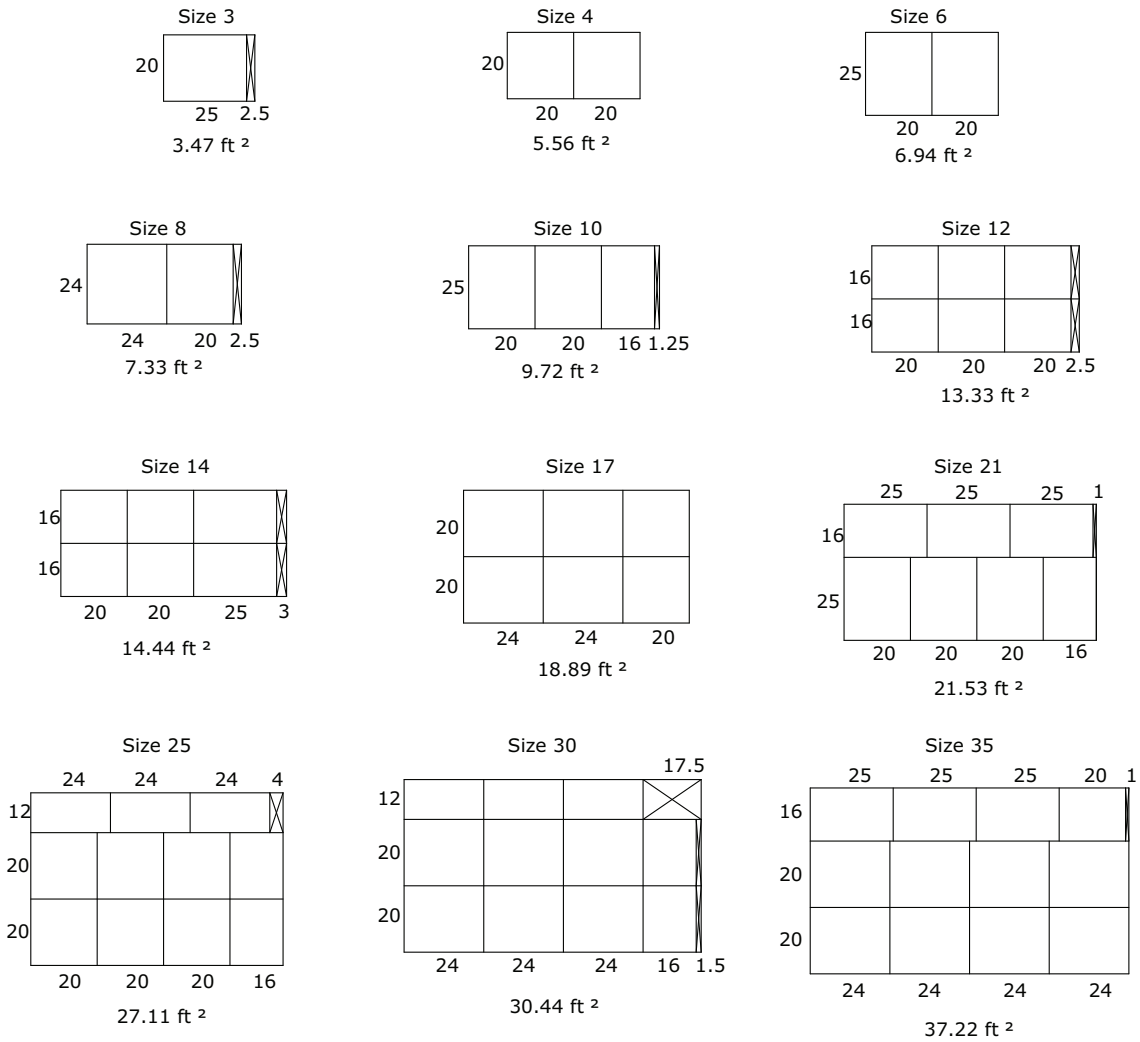
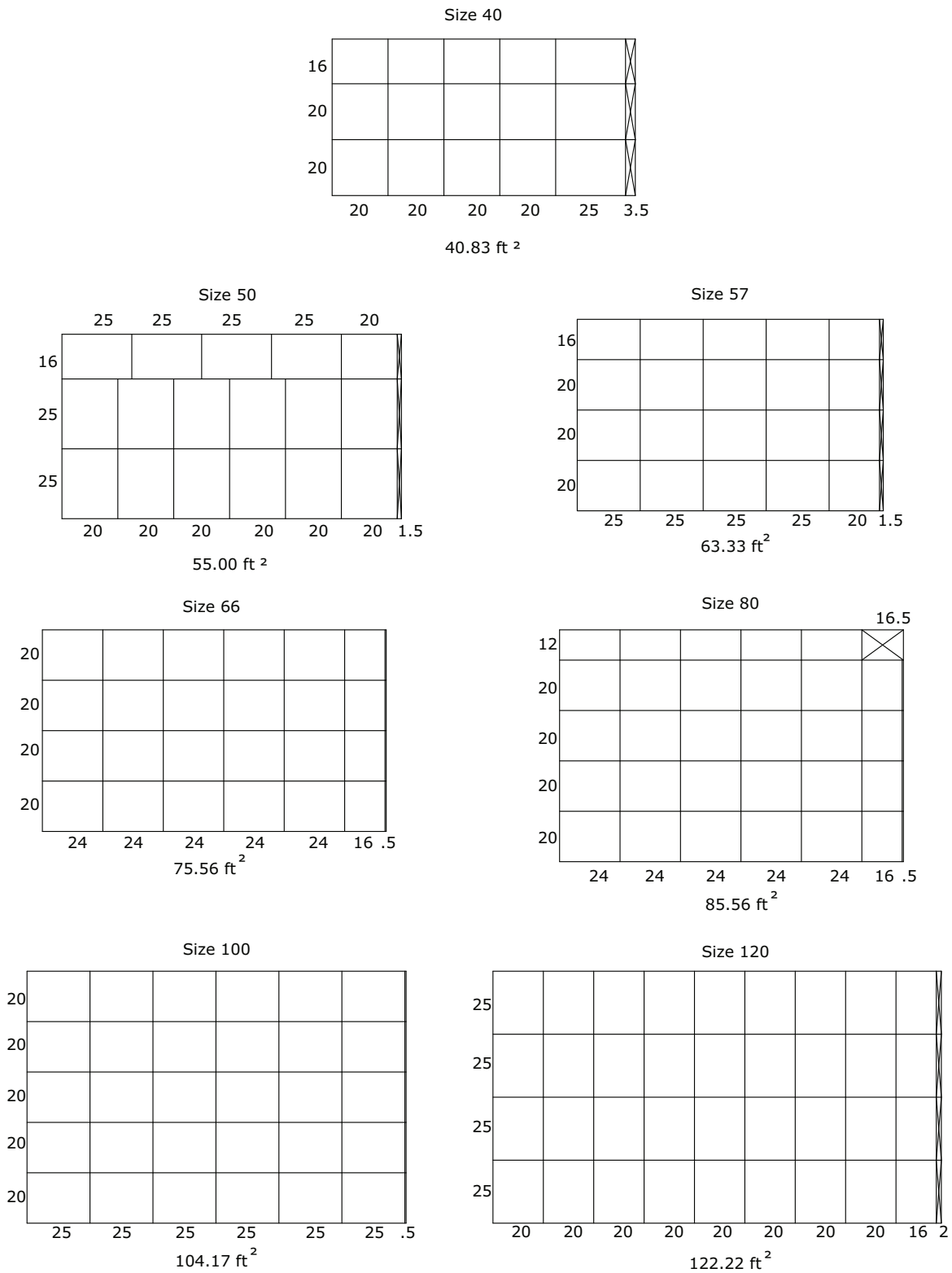
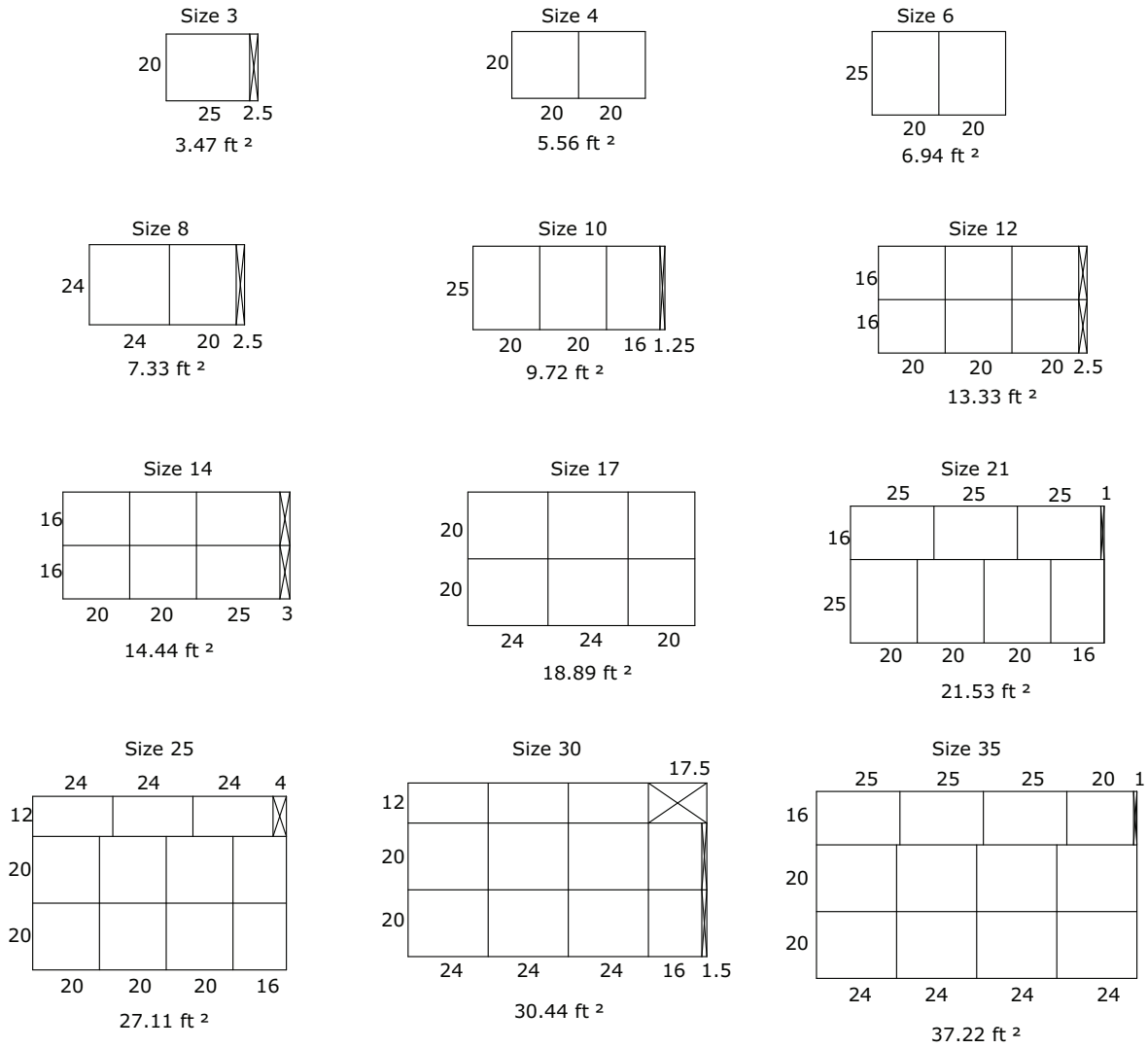
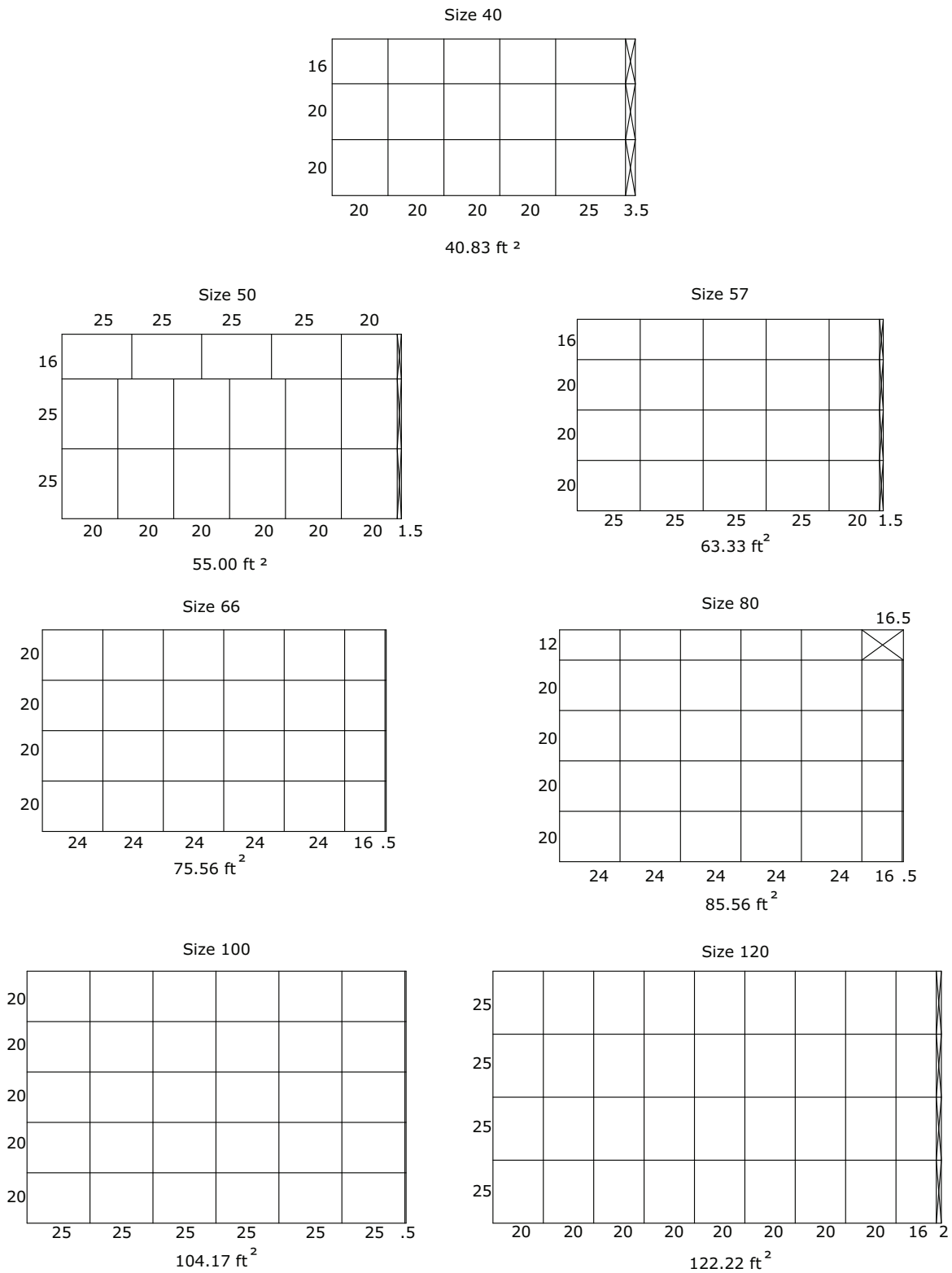

Figure 102. Side-loading 2-inch/4-inch combination flat filter placement for unit sizes 40-120



Component Installation

Figure 103. Side-loading 2-inch and 4-inch angled filter placement for unit sizes 3-35

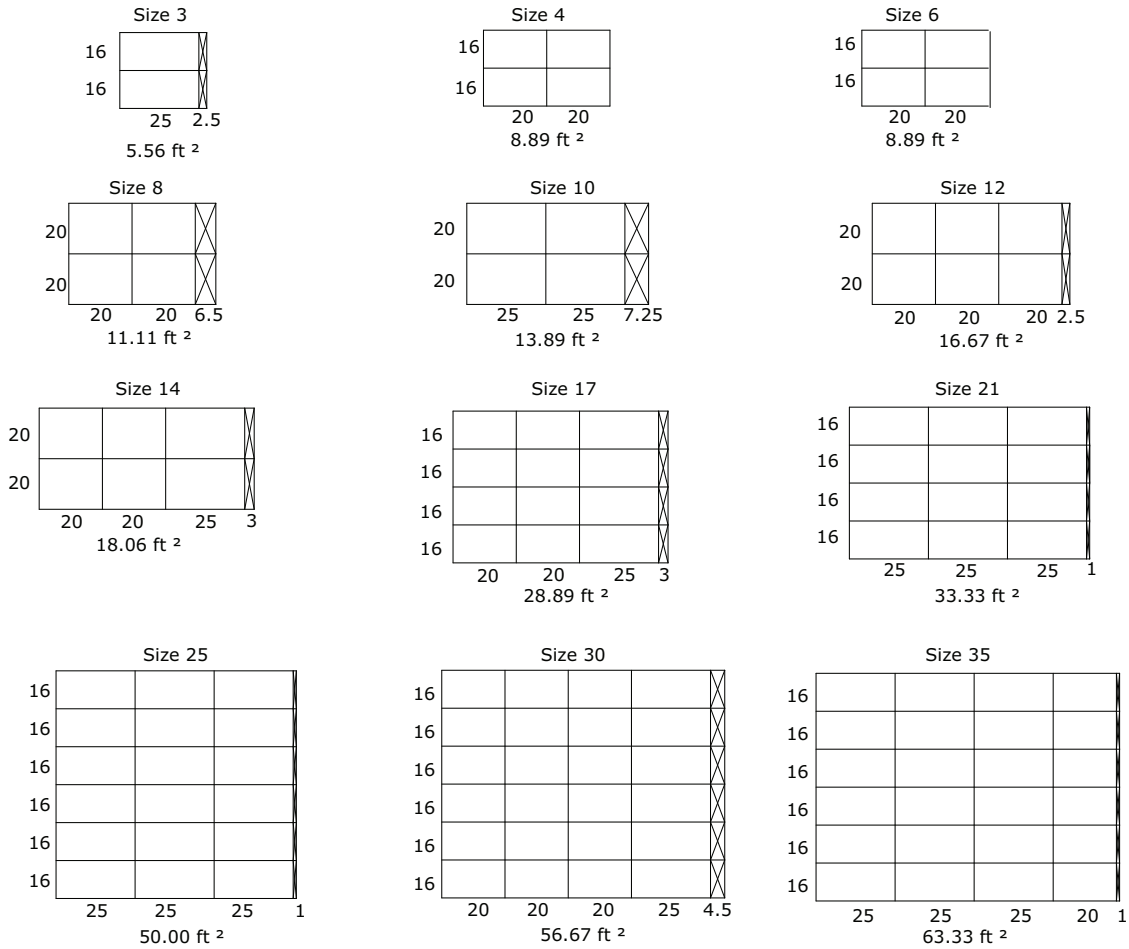
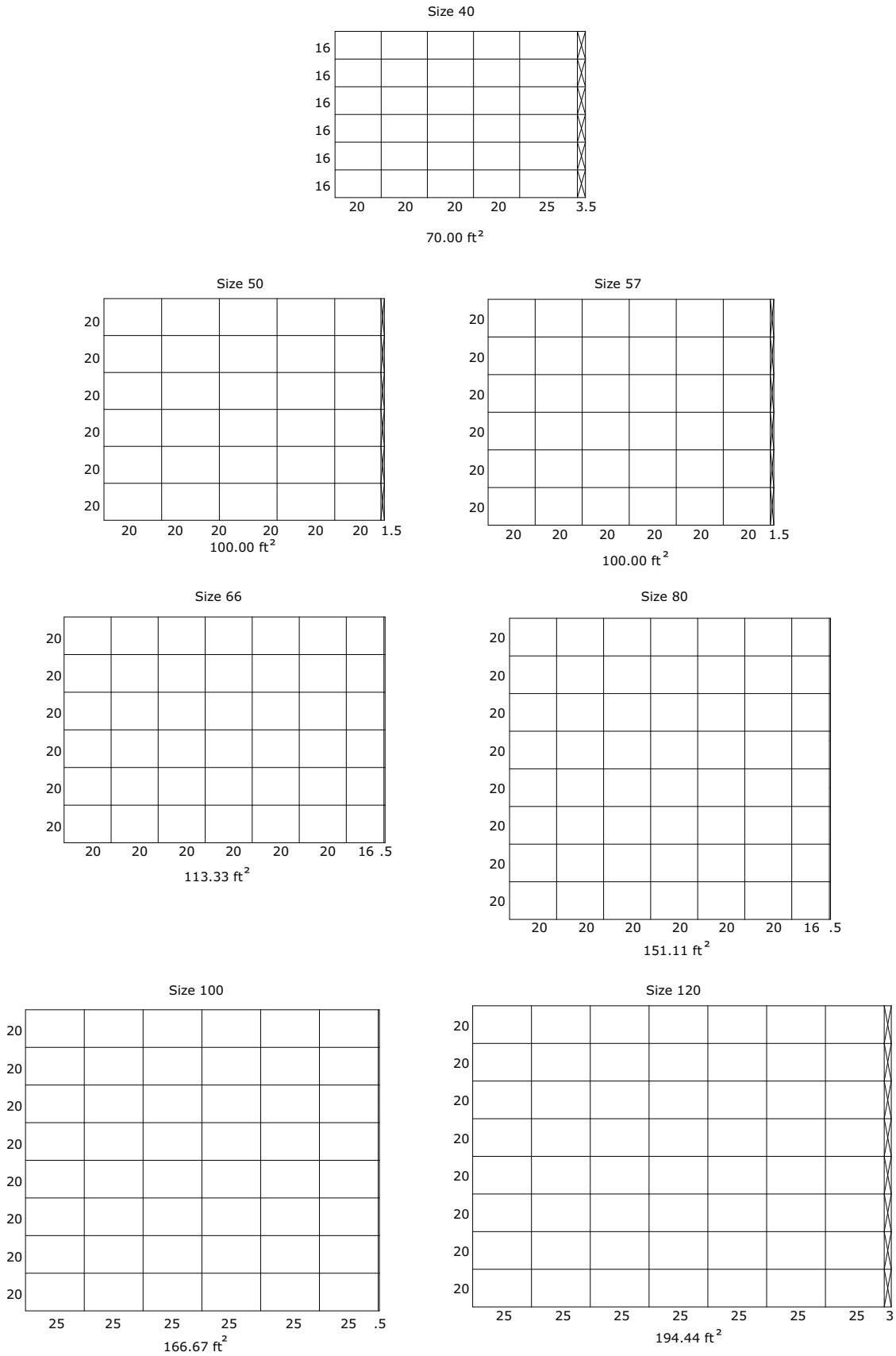

Figure 104. Side-loading 2-inch and 4-inch angled filter placement for unit sizes 40-120





Component Installation

Figure 105. Side-loading long bag filter placement for unit sizes 40-120

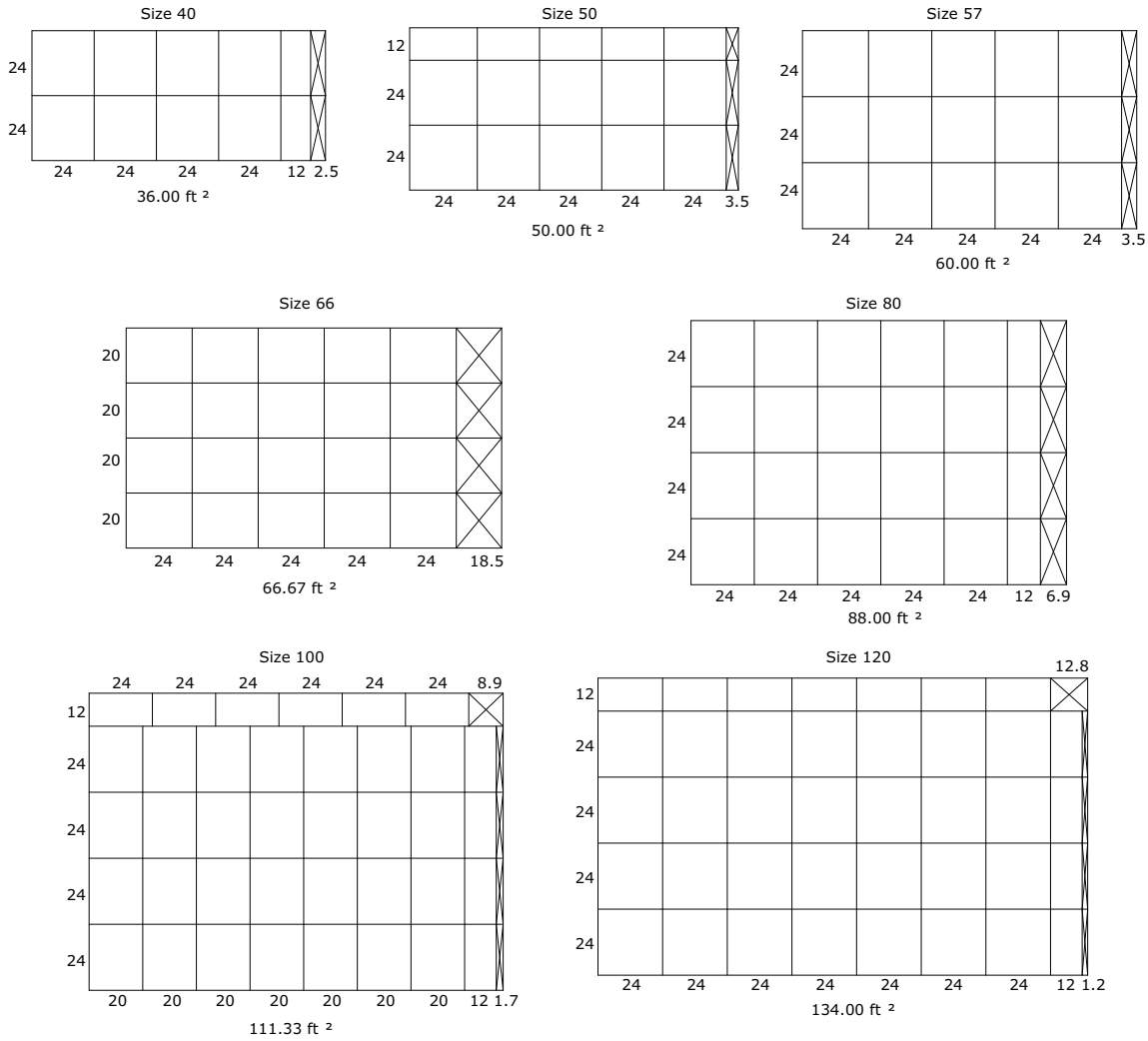
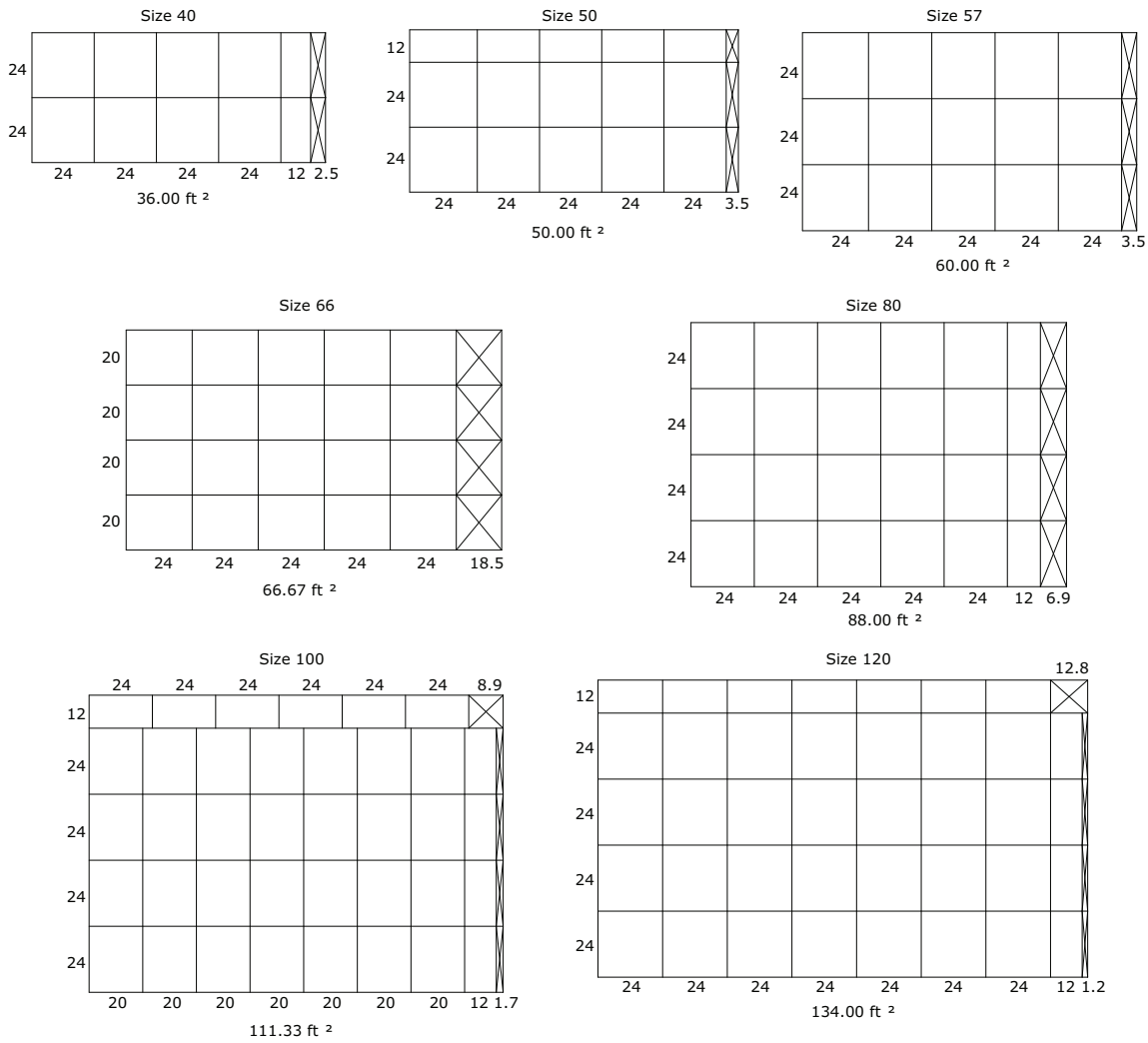

Figure 106. Side-loading short bag filter placement for unit sizes 40-120



Component Installation

Figure 107. Side-loading cartridge filter placement for unit sizes 3-35

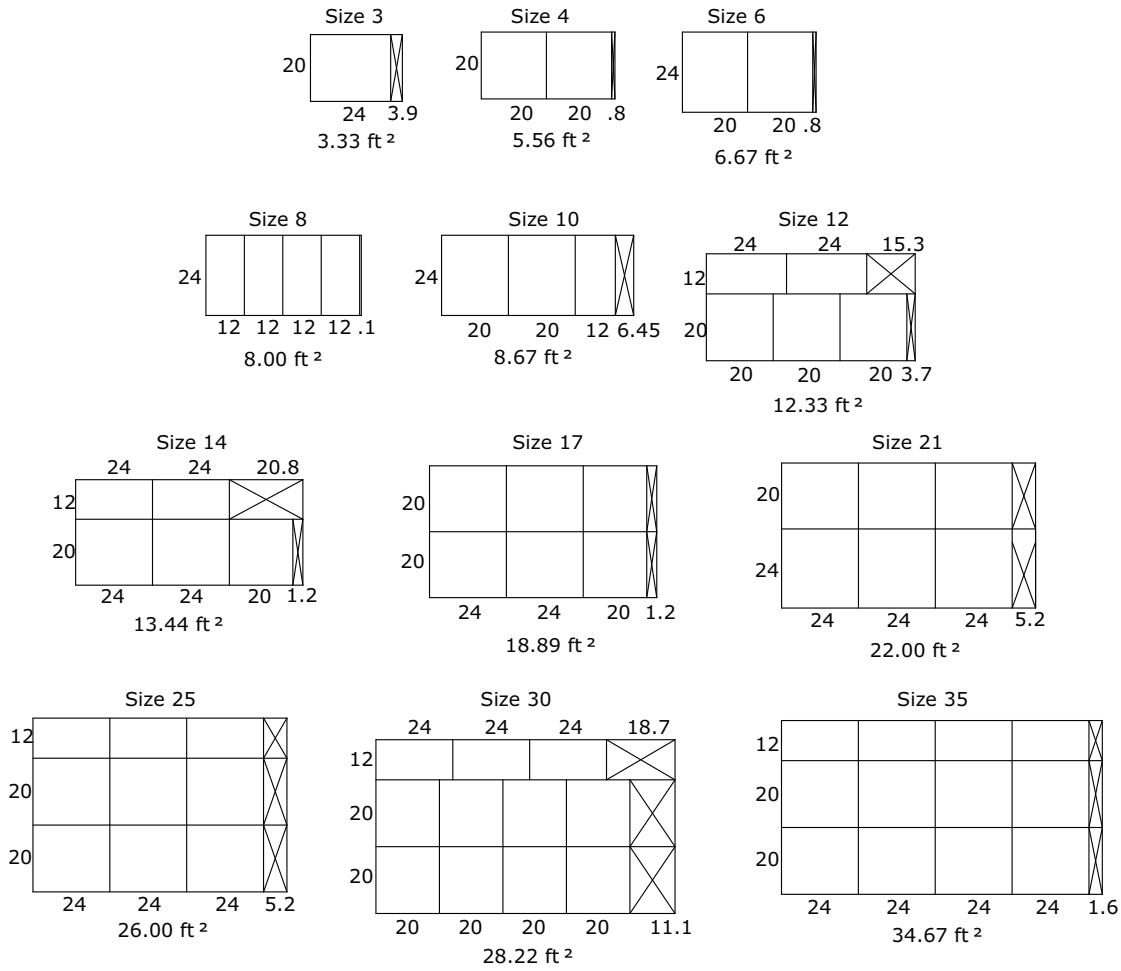

Figure 108. Side-loading cartridge filter placement for unit sizes 40-120

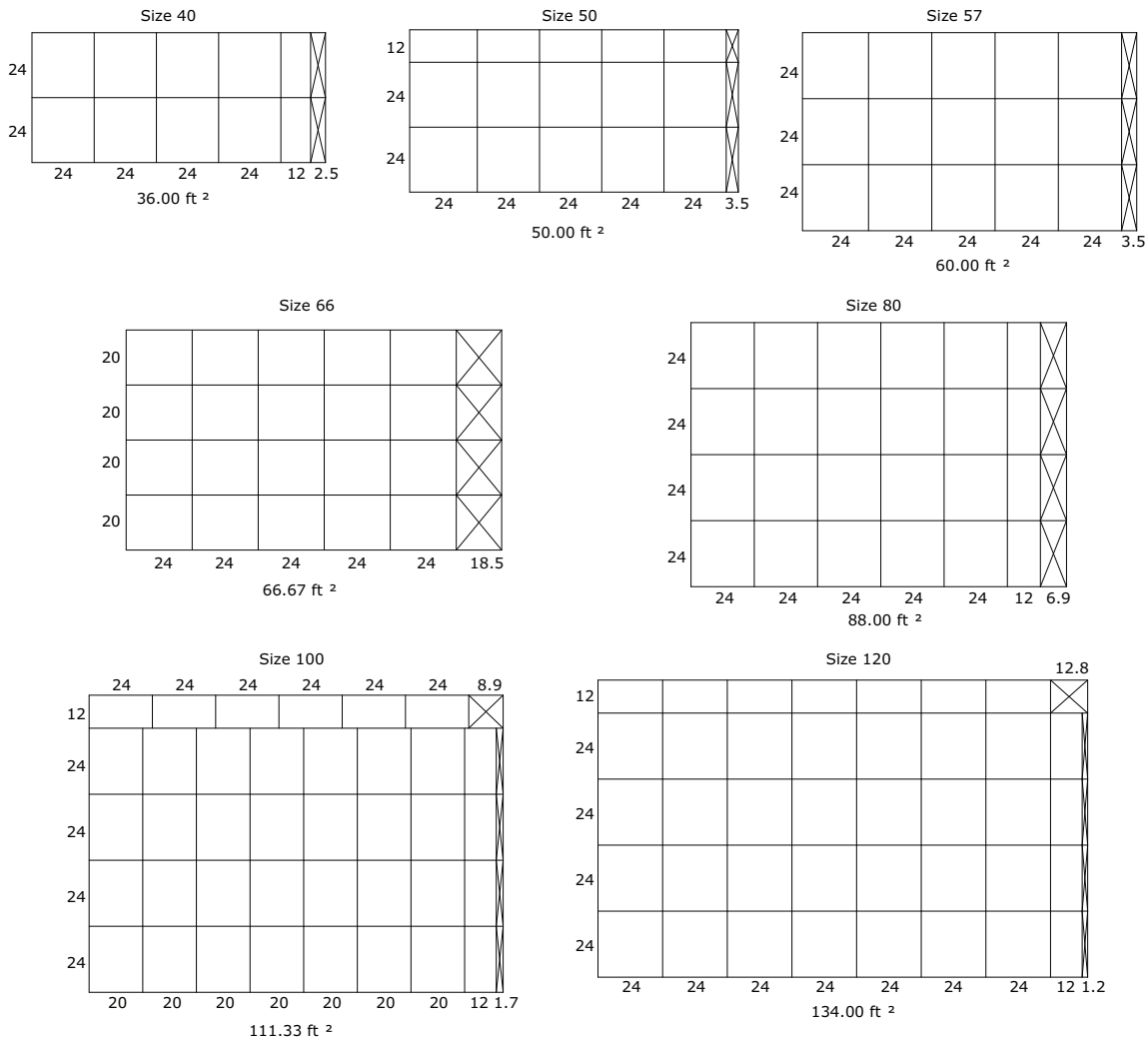

Figure 109. Front-loading 2-inch and 4-inch flat filter placement for unit sizes 3-35

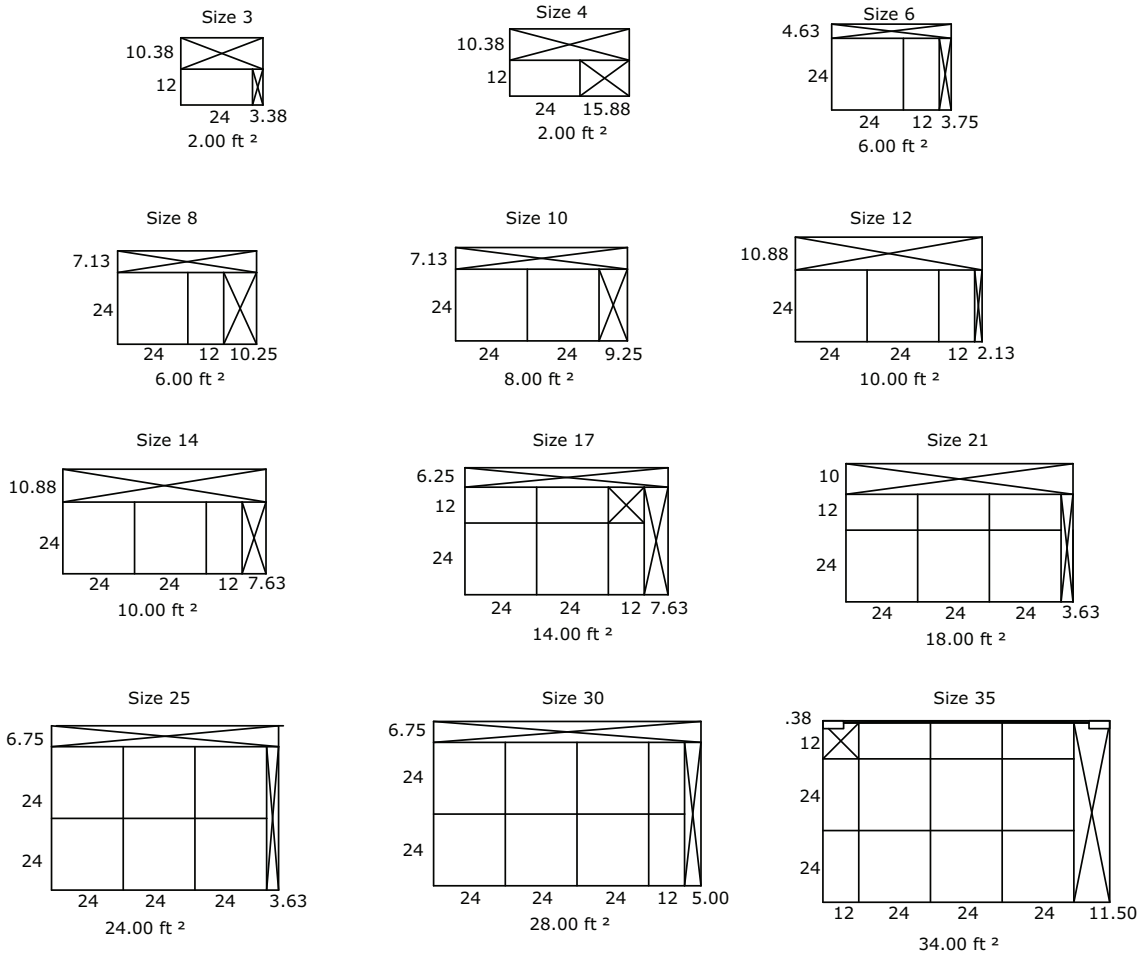

Figure 110. Front-loading 2-inch and 4-inch flat filter placement for unit sizes 40-120

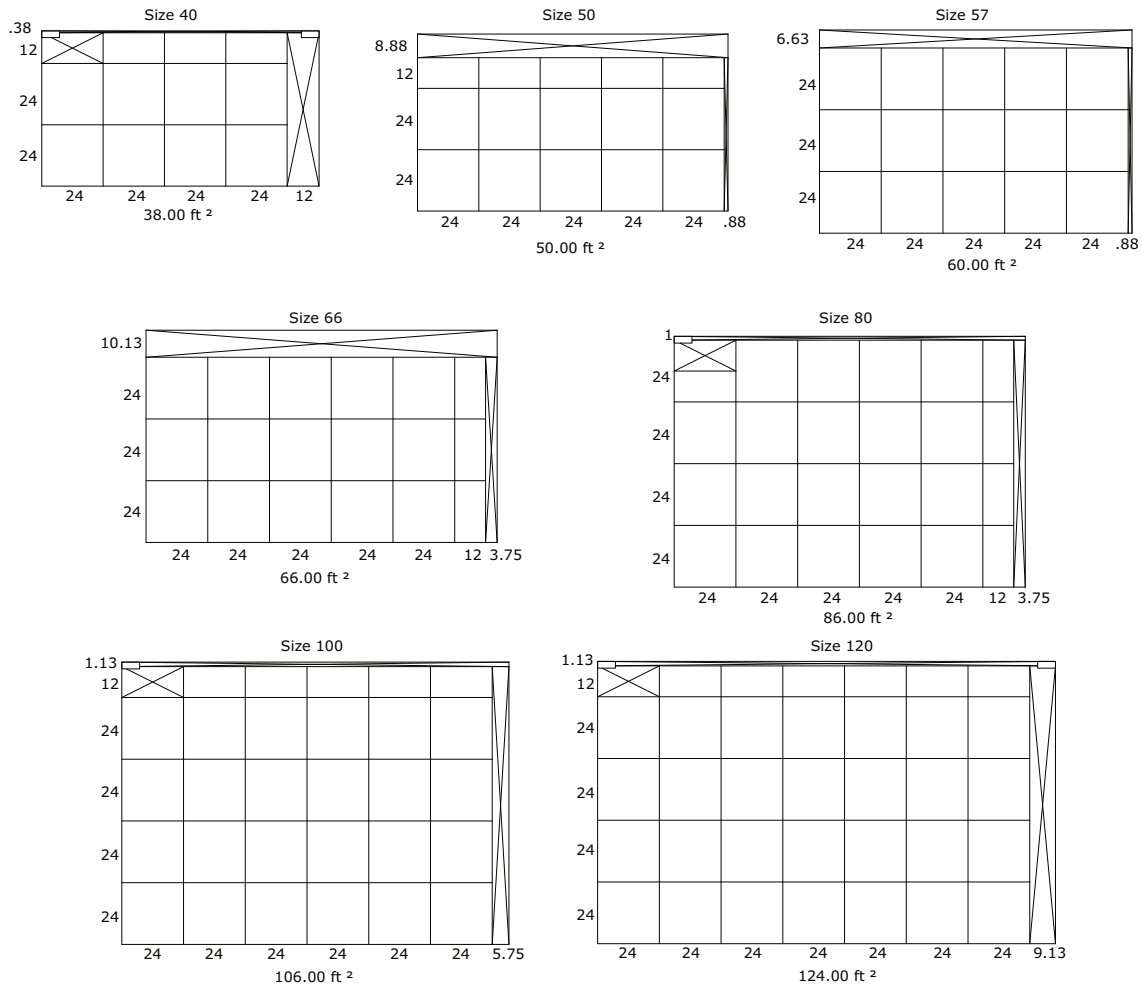

Figure 111. Front-load short bag filter placement for unit sizes 3-35

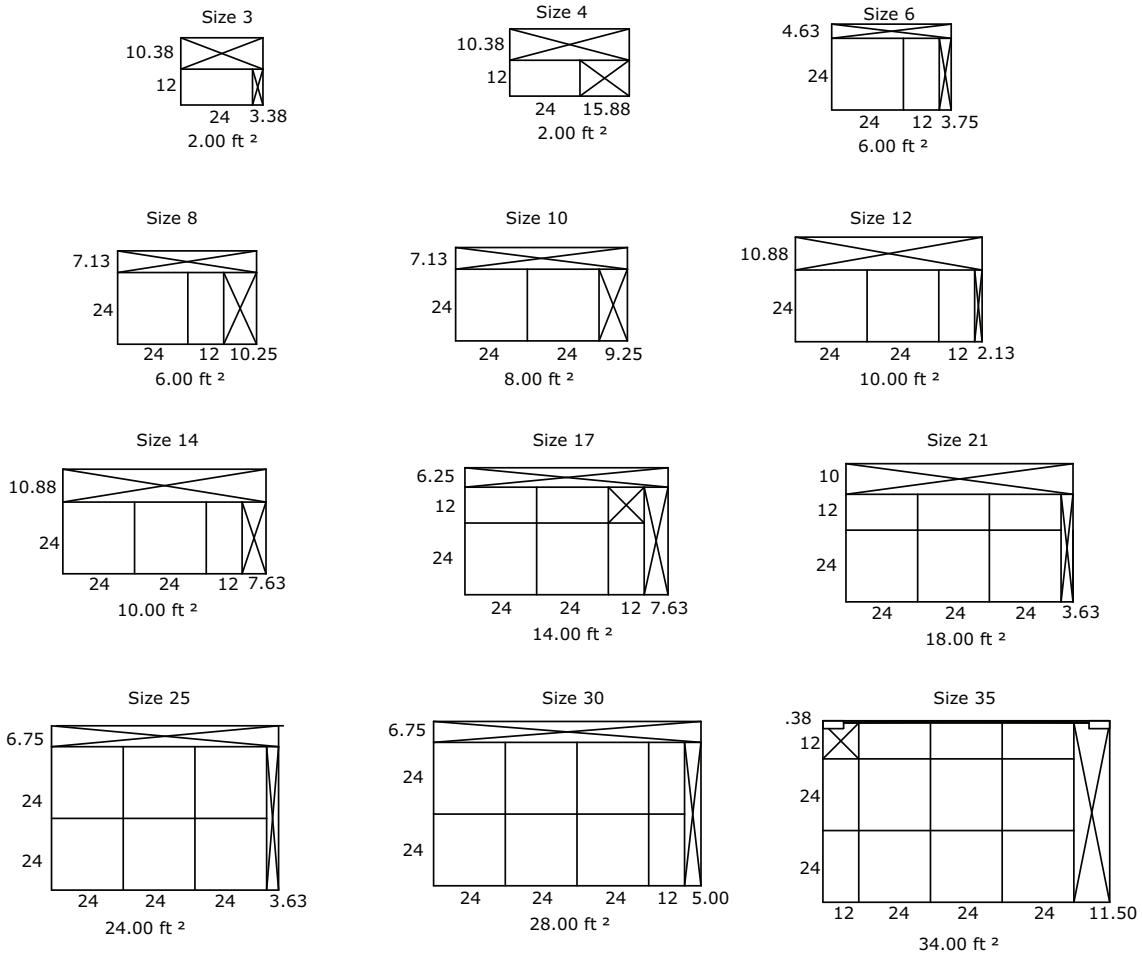
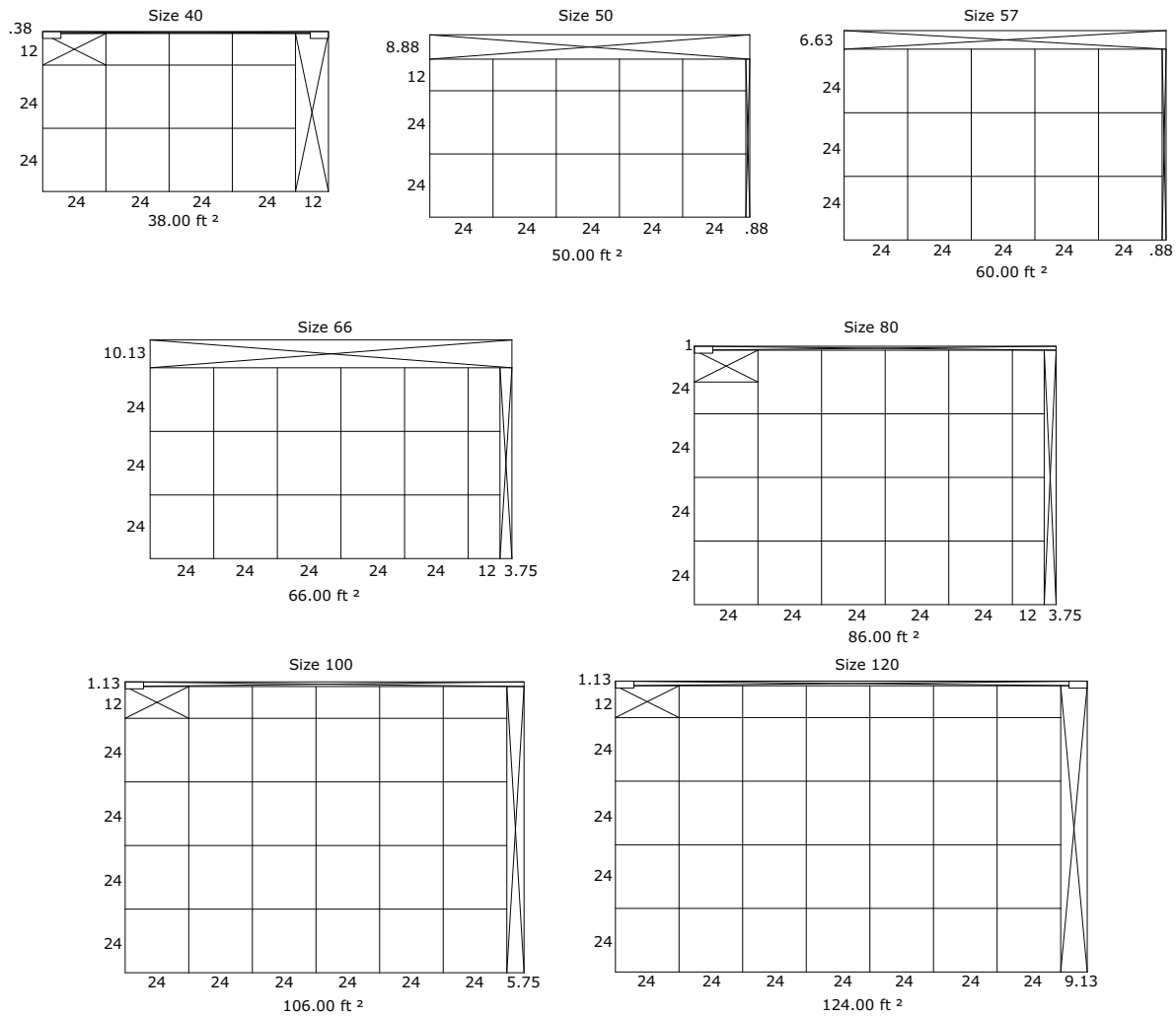

Figure 112. Front-loading short bag filter placement for unit sizes 40-120



Component Installation

Figure 113. Front-loading cartridge filter placement for unit sizes 3-35

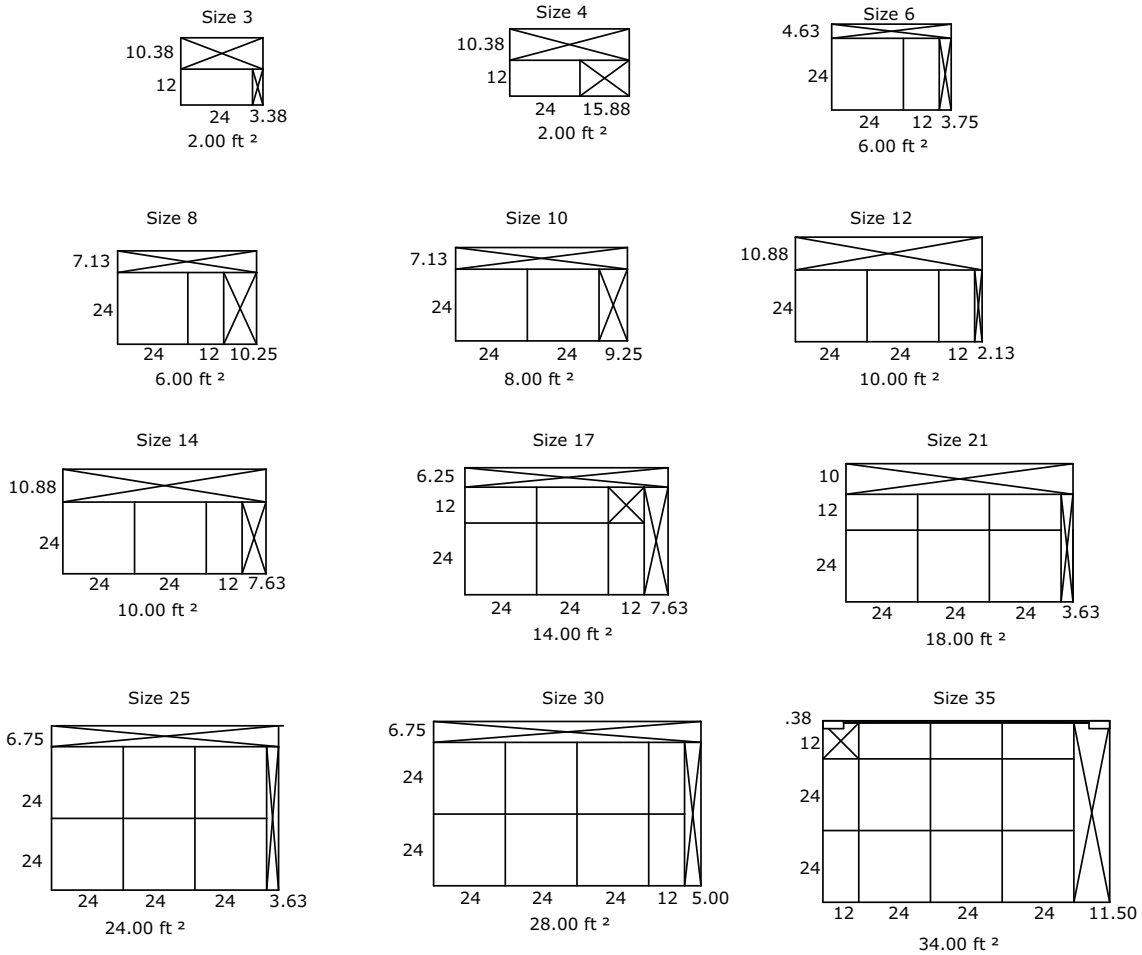

Figure 114. Front-loading cartridge filter placement for unit sizes 40-120

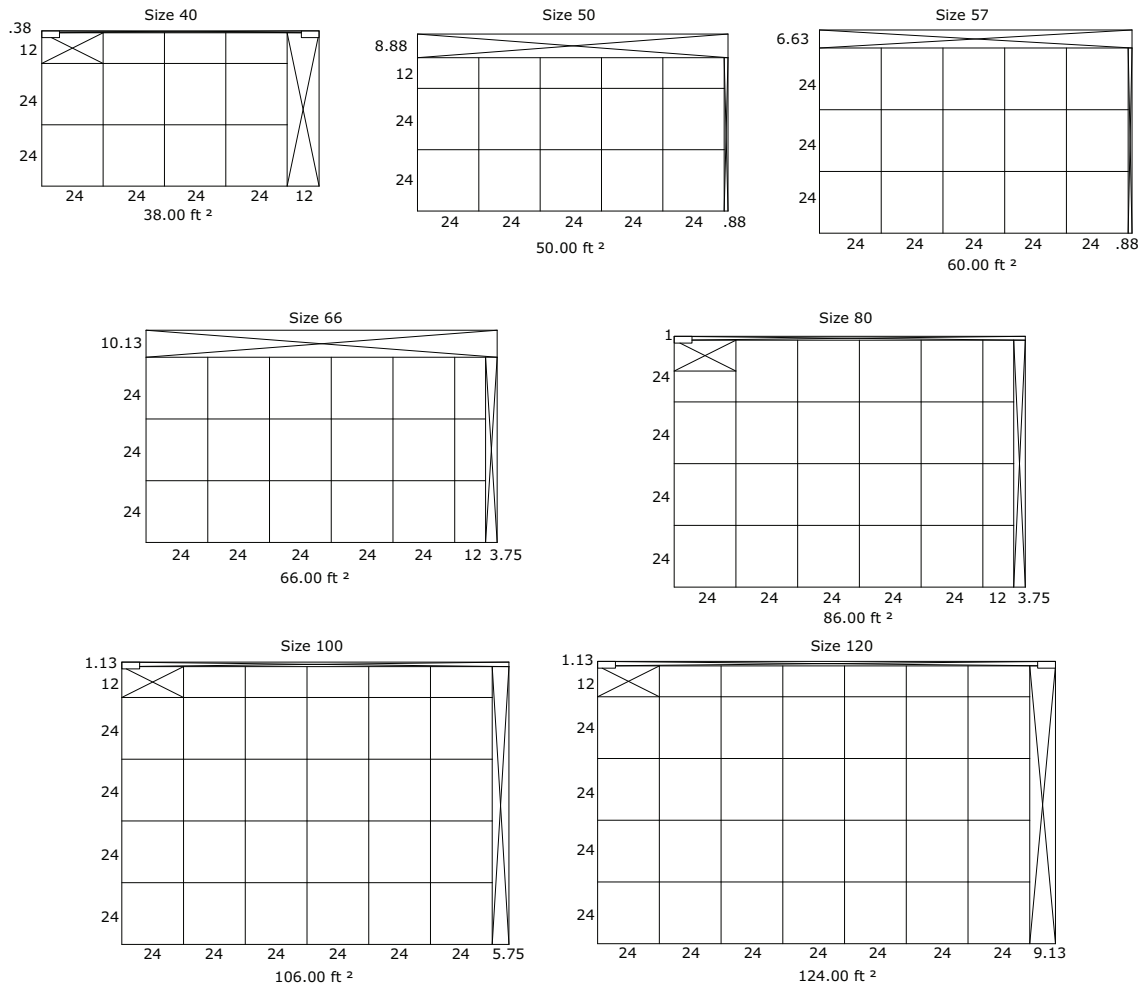

Figure 115. Front-loading HEPA filter placement for unit size 3-35

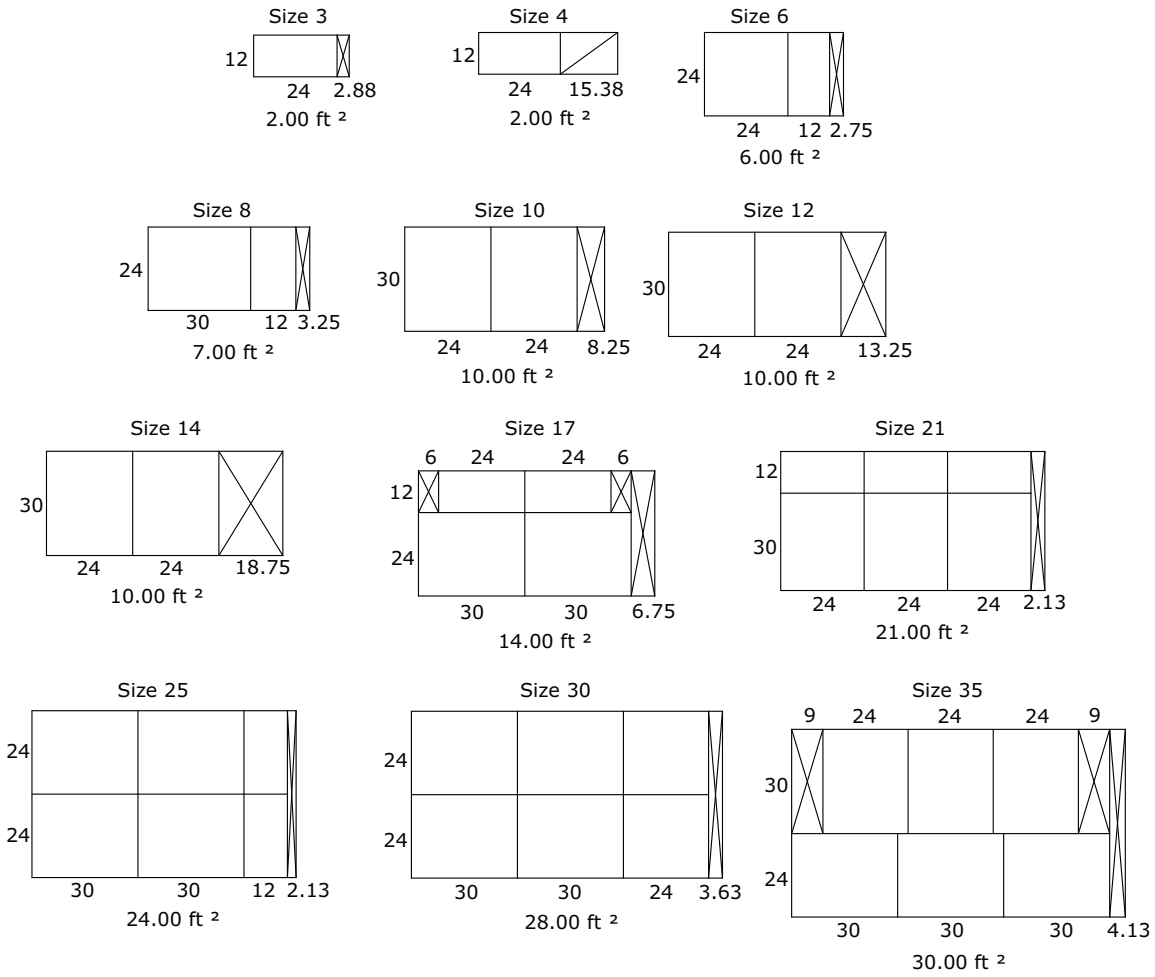
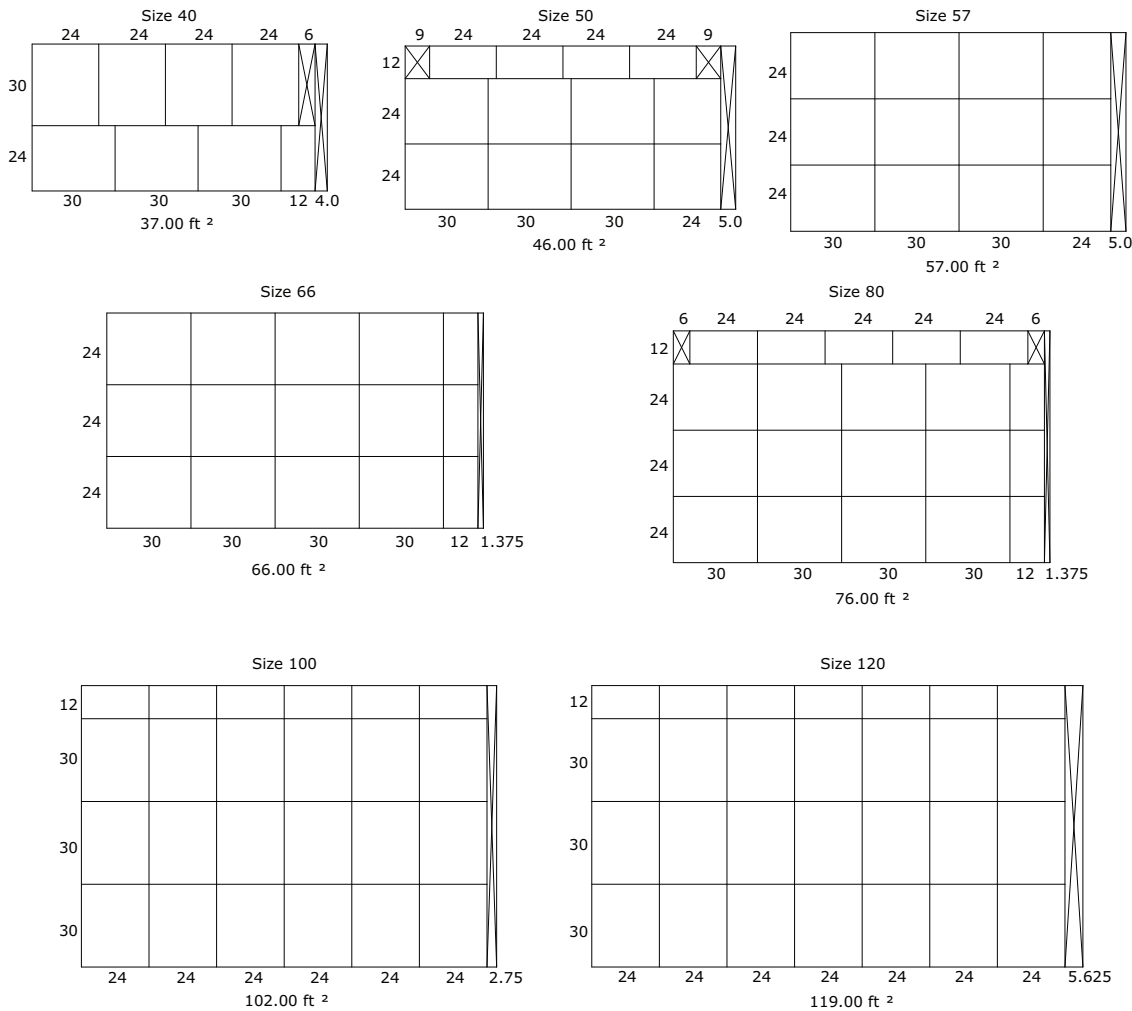

Figure 116. Front-loading HEPA filter placement for unit sizes 40-120

Duct Connections

All duct connections to the air handlers should be installed in accordance with the standards of the National Fire Protection Association (NFPA):

- NFPA 90A for installing air conditioning and ventilating systems other than residence type.
- NFPA 90B for residence-type warm air heating and airconditioning systems.

See unit submittal documentation for additional duct mounting information.

Fan Discharge Connections

To ensure the highest fan efficiency, duct turns and transitions must be made carefully, minimizing air friction losses and turbulence. Proper ductwork installation, as outlined by such organizations as Sheet Metal and Air Conditioning Contractors National Association, Inc. (SMACNA), should be followed closely.

Indoor unit fan sections with rectangular or round openings should have flanged ductwork attached to bottom panel opening. When using lined ducts, the insulation should not obstruct the discharge opening. For plenum fan sections with bell mouth fittings, see [“Bell Mouth Discharge Connections,” p. 103.](#)

Connections made directly to the discharge opening of a housed fan should have a minimum of three fan diameters of straight duct before any turns or transitions. The ductwork should be the same size as the fan discharge opening. The first turn of the connection should be in the same direction as the fan rotation as shown in [Figure 117, p. 102.](#) The air that the fan discharges into the duct is extremely turbulent and requires some length of duct to stabilize. Abrupt changes in ductwork directly off the fan discharge may adversely affect fan performance and acoustics.

Figure 117. Typical discharge ductwork recommendations

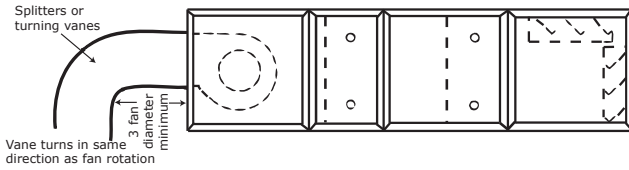

Damper Connections

Standard damper sections include mixing sections, filter mixing sections, face dampers sections, internal face-and-bypass sections. There are two damper blade configurations available - parallel-blade and opposed-blade. Traq™ dampers are another type of damper available in mixing box sections.

Ductwork attached to the standard damper sections should be sized to fit the opening of the damper. Duct opening dimensions are provided in the submittals. When using lined duct, ensure that the insulation does not obstruct the damper opening (see [Figure 118, p. 102](#) and [Figure 119, p. 102](#)).

Note: Damper blades should be checked for proper operation from full-open to full-closed position before unit start up. Damper blade positioning may have changed due to shipping and handling vibrations.

Figure 118. Typical duct flat/flange connection - uninsulated or externally insulated

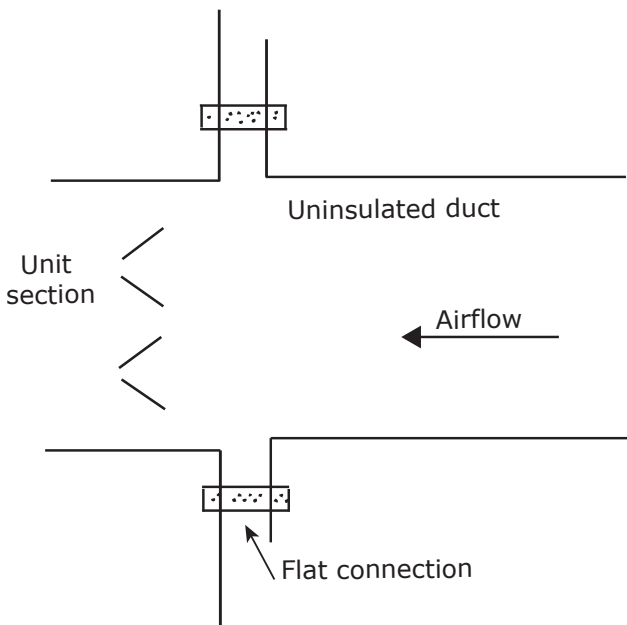
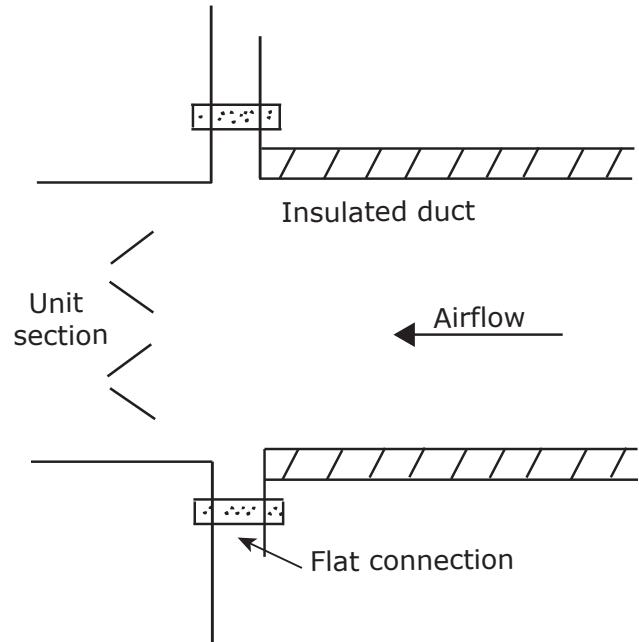

Figure 119. Typical section with duct flat/flange connection- internally insulated



Bottom Opening Duct Installation

1. Install gasket to duct flange to ensure air tight seal.
2. Install duct into place underneath framed opening in unit base per [Figure 120, p. 103](#). Refer to factory curb layout provided with unit submittals for duct size and location.
3. Bottom of unit base elevation is flush with duct opening in bottom of unit (see [Figure 121, p. 103](#) and [Figure 122, p. 103](#)).

Figure 120. Field-supplied duct connection to AHU bottom supply/return air opening

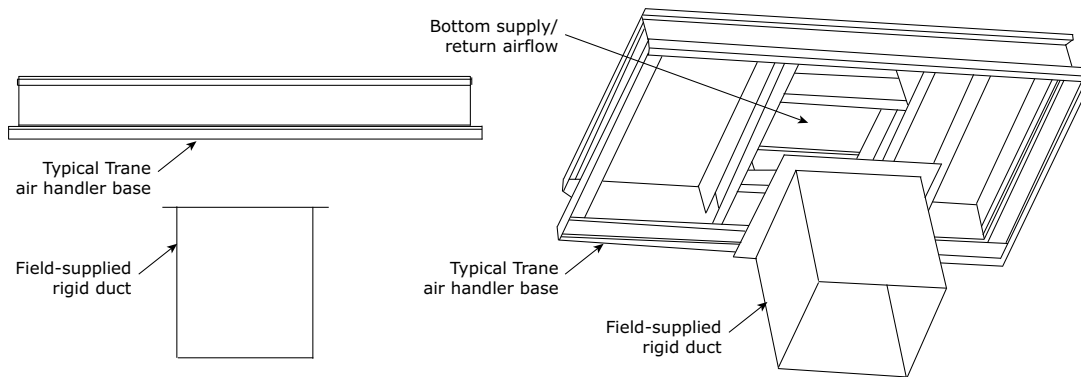

Figure 121. Field-supplied duct connection details - curb mount for outdoor units

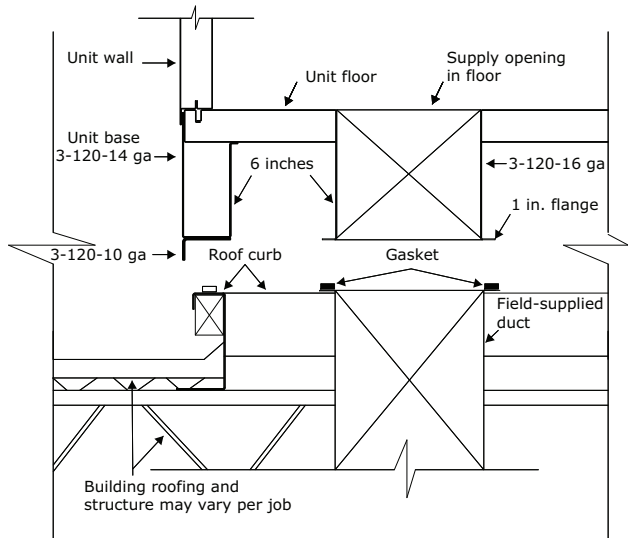
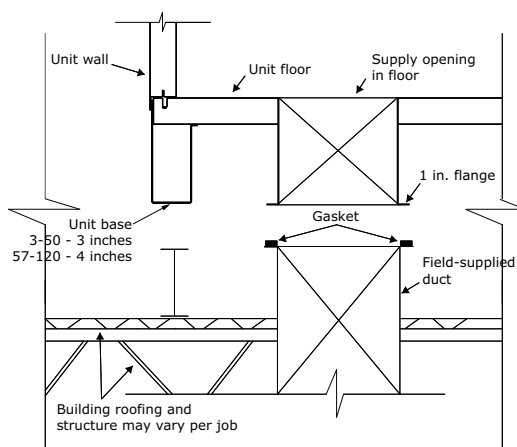

Figure 122. Field-supplied duct connection details - pier mount for outdoor units



have a framed opening that can be used to secure the duct to the frames. If the duct is lined, it is important the insulation does not obstruct the opening of the section.

For a discharge plenum with field-cut openings, attach the duct to the side panel.

Bell Mouth Discharge Connections

Round duct connections to be fastened to plenum fan and discharge plenum sections with bell mouth discharge openings should be sized to attach to the casing or directly to the bell mouth fitting. Attachment to the casing requires the round duct diameter to be sized two inches larger than the nominal bell mouth outlet. An angle ring with a flat flange should be affixed to the round duct to secure the duct to the casing (see [Figure 123, p. 103](#)). Attachment to the bell mouth fitting requires the duct and fitting to be insulated by the installing contractor up to the bell mouth radius to prevent condensation (see [Figure 124, p. 104](#)). The bell mouth fitting extends through the casing by one inch.

Figure 123. Securing round duct to casing over bell mouth outlet

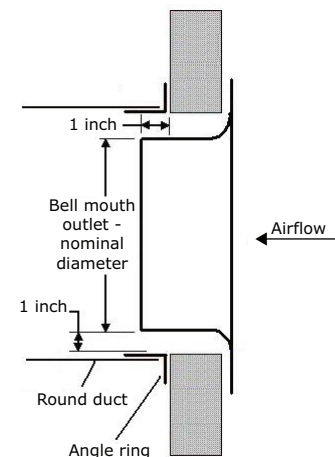

Discharge Plenum Connections

Discharge plenum sections are available with or without openings. Sections with rectangular and round openings

Figure 124. Securing round duct to bell mouth outlet

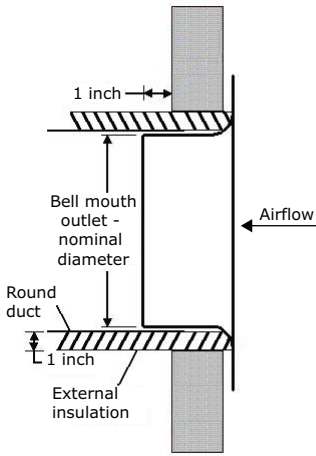
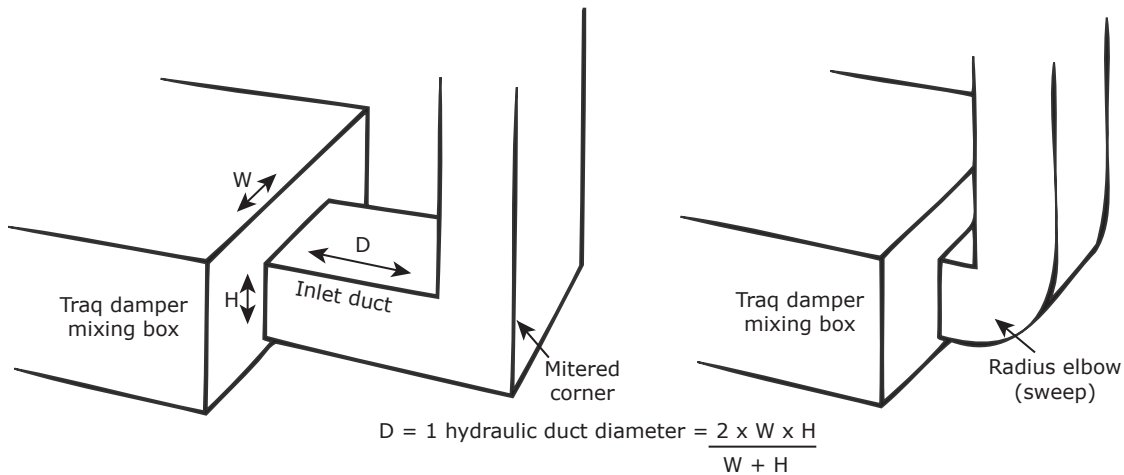

Figure 125. Traq damper duct connections



Traq Damper Connections

Size the duct connections to attach to the specified portion on the face of the mixing box that the duct connection completely covers all of the Traq damper.

For a mitered corner, provide one hydraulic duct diameter between the entering face of the Traq dampers and the duct turn. For a radius elbow, or sweep, place the elbow directly against the face of the Traq dampers (see [Figure 125, p. 104](#)).

Other Connections

Access, filter, and other sections may have open inlets with a 2-inch (sizes 3-120) panel frame for connecting the ductwork. If the duct is lined, it is important the insulation does not obstruct the opening of the section.

Note: If unit has a duct heater on a fan discharge there is a minimum clearance from combustible materials 1-inch for first four feet of duct.

Figure 126. Typical duct flat/flange end-of-unit (EOU) connection - uninsulated

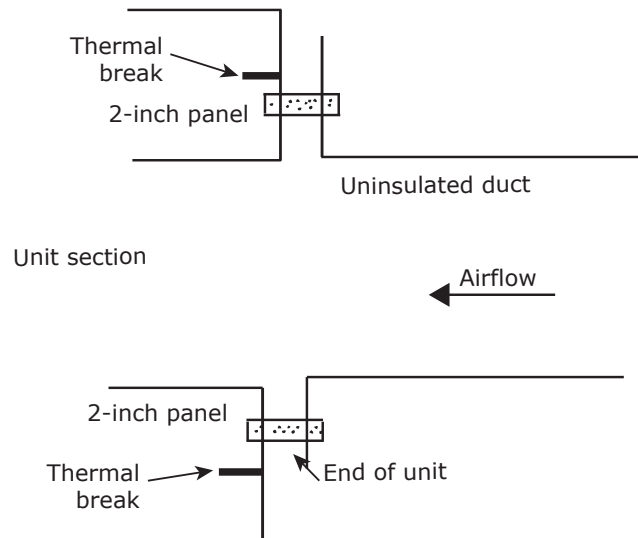
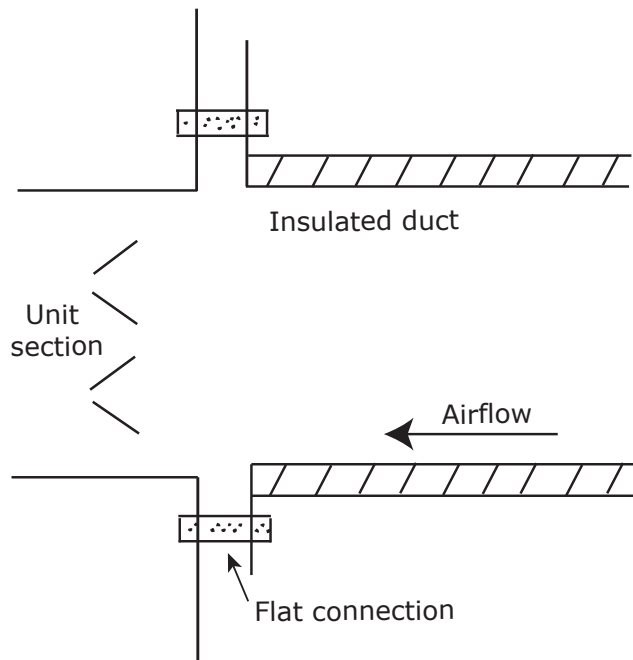

Figure 127. Typical duct flat/flange end-of-unit (EOU) connection - insulated





Piping and Connections

NOTICE

Connection Leaks!

Failure to follow instructions below could result in damage to the coil header and cause connection leaks.

Use a backup wrench when attaching piping to coils with copper headers. Do not use brass connectors because they distort easily.

NOTICE

Overtightening!

Failure to follow instructions below could result in damage to the coil header.

Do not use teflon-based products for any field connections because their high lubricity could allow connections to be overtightened.

NOTICE

Leakage!

Failure to follow instructions below could result in equipment damage.

Properly seal all penetrations in unit casing from inner to outer panel in order to prevent unconditioned air from entering the module, as well as prevent water from infiltrating the insulation.

General Recommendations

Proper installation, piping, and trapping is necessary to ensure satisfactory coil operation and to prevent operational damage:

- Support all piping independently of the coils.
- Provide swing joints or flexible fittings on all connections that are adjacent to heating coils to absorb thermal expansion and contraction strains.
- If the coil was ordered with factory-mounted controls, install the control valves. The valves ship separately.

Note: The contractor is responsible for supplying the installation hardware.

- For best results, use a short pipe nipple on the coil headers prior to making any welded flange or welded elbow type connections.
- Extended drain and vent connections are provided as standard on D1 and D2 coils only. If extended drains and vents are required on other water coils, they must be field-installed or ordered as specials from the factory.

Note: Drain and vent connections are optional for standard coils. Penetrations will not be in the panel; a pilot hole will be factory-provided if drain and vent connections are indicated.

- Pipe coils counter flow to airflow.
- When attaching the piping to the coil header, make the connection only tight enough to prevent leaks.

Note: Do not exceed 200 foot-pounds of torque on supply and return connections. Do not exceed 25 foot-pounds of torque on drain and vent connections.

- Use pipe sealer on all thread connections.
- After completing the piping connections, seal around pipe from inner panel to outer panel.

Drain Pan Trapping

⚠ WARNING

No Step Surface!

Failure to follow instruction below could result in death or serious injury.

Do not walk on the sheet metal drain pan. Walking on the drain pan could cause the supporting metal to collapse and result in the operator/technician falling.

NOTICE

Water Damage!

Failure to follow instructions below could result in water damage.

When more than one section has a drain pan, trap each section individually. Connecting multiple drains to a common line with only one trap could result in condensate retention and water damage to the air handler or adjoining space.

Threaded condensate drain connections are provided on only one side of the coil section. Pitch the connection lines horizontal or downward toward an open drain. Trane recommends installing a plug to facilitate cleaning of the trap.

Table 33. Drain connection size

Unit size	NPT (national pipe thread) external connection
3-30	1-inch
35-57	1 1/4-inch
66-120	1 1/2-inch

Figure 128, p. 107 illustrates the proper trapping, piping, and operation of the trap. Use the formula under the figure to determine the correct minimum depth for the condensate trap. If a section has a drain pan for cleaning purposes only, it does not need a trap; however, a cap or shutoff valve should be installed on the drain connection. Only sections handling condensate, such as a cooling coil section or moisture eliminator section, require a trap.

Figure 128. Drain pan trapping for negative and positive pressure applications

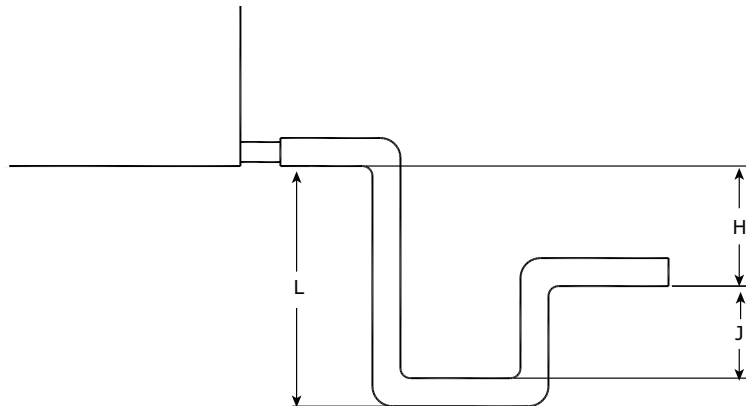

Section under negative pressure

Section under positive pressure

$L = H + J + \text{pipe diameter}$ where:
 $H = 1$ inch for each inch of negative pressure plus 1 inch with loaded filters
 $J = 1/2 H$

$L = H + J + \text{pipe diameter}$ where:
 $H = 1/2$ inch (minimum)
 $J = 1/2$ inch plus the unit positive static pressure at coil discharge (loaded filters)

Steam Coil Piping

Air handlers fitted with steam coils have labeled holes for piping penetrations. Figure 129, p. 107 illustrates a typical steam coil piping configuration. See Table 34, p. 107 for the codes of system components in these figures.

The coil condensate return line must be piped full size of the condensate trap connection, except for a short nipple screwed directly into the coil header's condensate return tapping. Do not bush or reduce the coil return trapping size.

Table 34. Code of system components for piping figures

Code	System component
FT	Float and thermostatic steam trap
GV	Gate valve
OV	Automatic two-position (ON-OFF) control valve
VB	Vacuum breaker
ST	Strainer
AV	Automatic or manual air vent
MV	Modulating control valve

Figure 129. Typical piping for Type NS steam coils and horizontal tubes for horizontal airflow

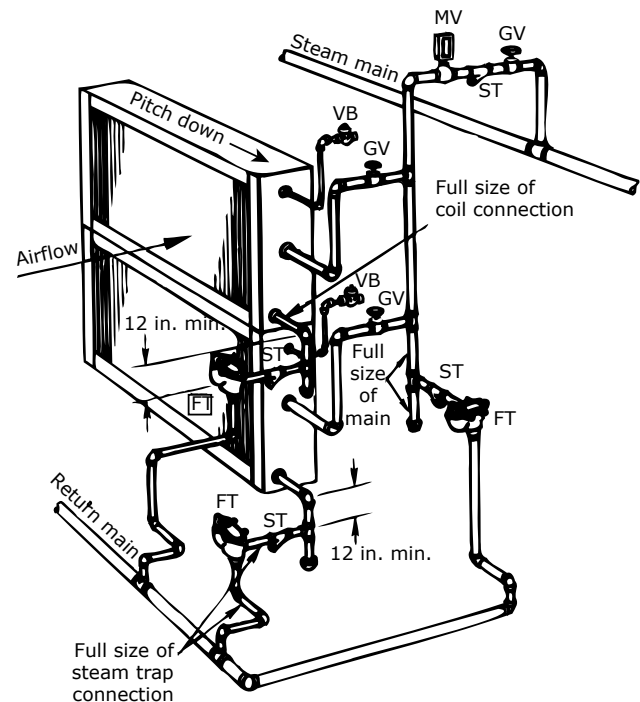

NOTICE

Equipment Damage!

Failure to follow instructions below could result in equipment damage.

Use only the recommended vacuum breaker size and configuration.

To prevent coil damage:

Piping and Connections

- Install a 1/2-in. NPT, 15 degree swing check valve vacuum breaker with cracking pressure of 0.25-inches Hg (3.4-inches water) or lower at the top of the coil. This vacuum breaker should be installed as close to the coil as possible.
- For coil type NS, install the vacuum breaker in the unused condensate return tapping at the top of the coil.
- Vent the vacuum breaker line to atmosphere or connect it into the return main at the discharge side of the steam trap.

Note: Vacuum breaker relief is mandatory when the coil is controlled by a modulating steam supply or automatic two position (ON-OFF) steam supply valve. Vacuum breaker relief is also recommended when face and bypass control is used.

NOTICE

Coil Damage!

Failure to follow instructions below could result in equipment damage.

Condensate must flow freely from the coil at all times to prevent coil damage from water hammer, unequal thermal stresses, freeze-up and/or corrosion.

Proper steam trap installation is necessary for satisfactory coil performance and service life. For steam trap installation:

1. Install the steam trap discharge 12-inches below the condensate return connection. Twelve inches provides sufficient hydrostatic head pressure to overcome trap losses and ensures complete condensate removal.
 - a. Use float and thermostatic traps with atmospheric pressure gravity condensate return, with automatic controls, or where the possibility of low-pressure supply steam exists. (Float and thermostatic traps are recommended because of gravity drain and continuous discharge operation.)
 - b. Use bucket traps only when the supply steam is not modulated and is 25 psig or higher.
- Note:** Trane steam coils require a minimum of 2 psi of pressure to assure even heat distribution.
2. Trap each coil separately to prevent holding up condensate in one or more of the coils.
 3. Install strainers as close as possible to the inlet side of the trap.
 4. If installing coils in series airflow, control each coil bank independently with an automatic steam-control valve. Size the traps for each coil using the capacity of the first coil in direction of airflow.
 5. Use a modulating valve that has linear flow characteristics to obtain gradual modulation of the coil steam supply.

Note: Do not modulate systems with overhead or pressurized returns unless the condensate is drained by gravity into a receiver, vented to atmosphere, and returned to the condensate pump.

6. Pitch all supply and return steam piping down 1-inch for every 10-feet in the direction of the steam or condensate flow.

Note: Do not drain the steam mains or take-offs through the coils. Drain the mains ahead of the coils through a steam trap to the return line.

7. Ensure overhead returns have 1 psig of pressure at the steam trap discharge for every 2-feet of elevation for continuous condensate removal.

Water Coil Piping

Type 3W, 5W, D1, W, UW, TT, water coils are self-venting only if the water velocity exceeds 1.5 feet per second (fps) in the coil tubes. Type D2, UA, UU, 3U, and WD water coils are self-venting only if the water velocity exceeds 2.5 fps in the coil tubes.

See the unit submittals for coil water velocity. If the water velocity is below these minimums, vent the coil by one of the following methods:

1. Install an air vent in the top pipe plug tapping of the return header.
2. When the return line rises above the top of the coil, vent from the top of the return header horizontally to the return piping.

Note: TT coils are designed with larger than normal end tube sheet holes to allow for maximum expansion. Air leakage around tubes should be expected and handled by capping over coil ends or by sealing around tubes with a pliable sealant such as silicone.

Figure 130. Typical piping for type 5W one-row water coil

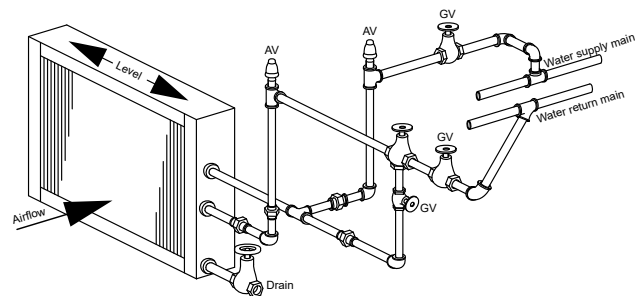

Figure 131. Typical piping for type 5W two-row, W 3- to 12-row, WD, D1, and D2 water coils

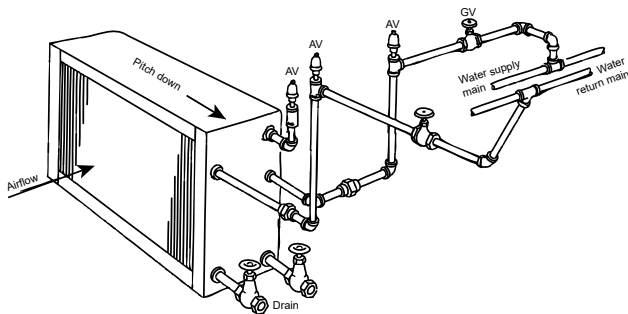
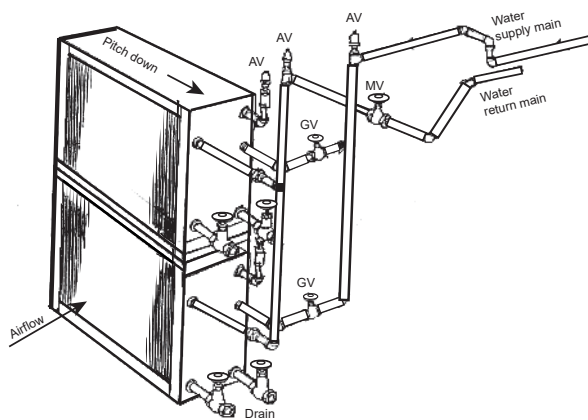

Figure 132. Typical piping for stacked water coils



Refrigerant Coil Piping

Note: See the information on handling refrigerants.

Figure 133, p. 110 illustrates an example of a split-system component arrangement. Use it to determine the proper, relative sequence of the components in the refrigerant lines that connect the condensing unit to an evaporator coil. See the “Field-Installed Evaporator Piping,” p. 114 for more detailed schematics of evaporator piping.

Figure 133. Example of placement for split-system components

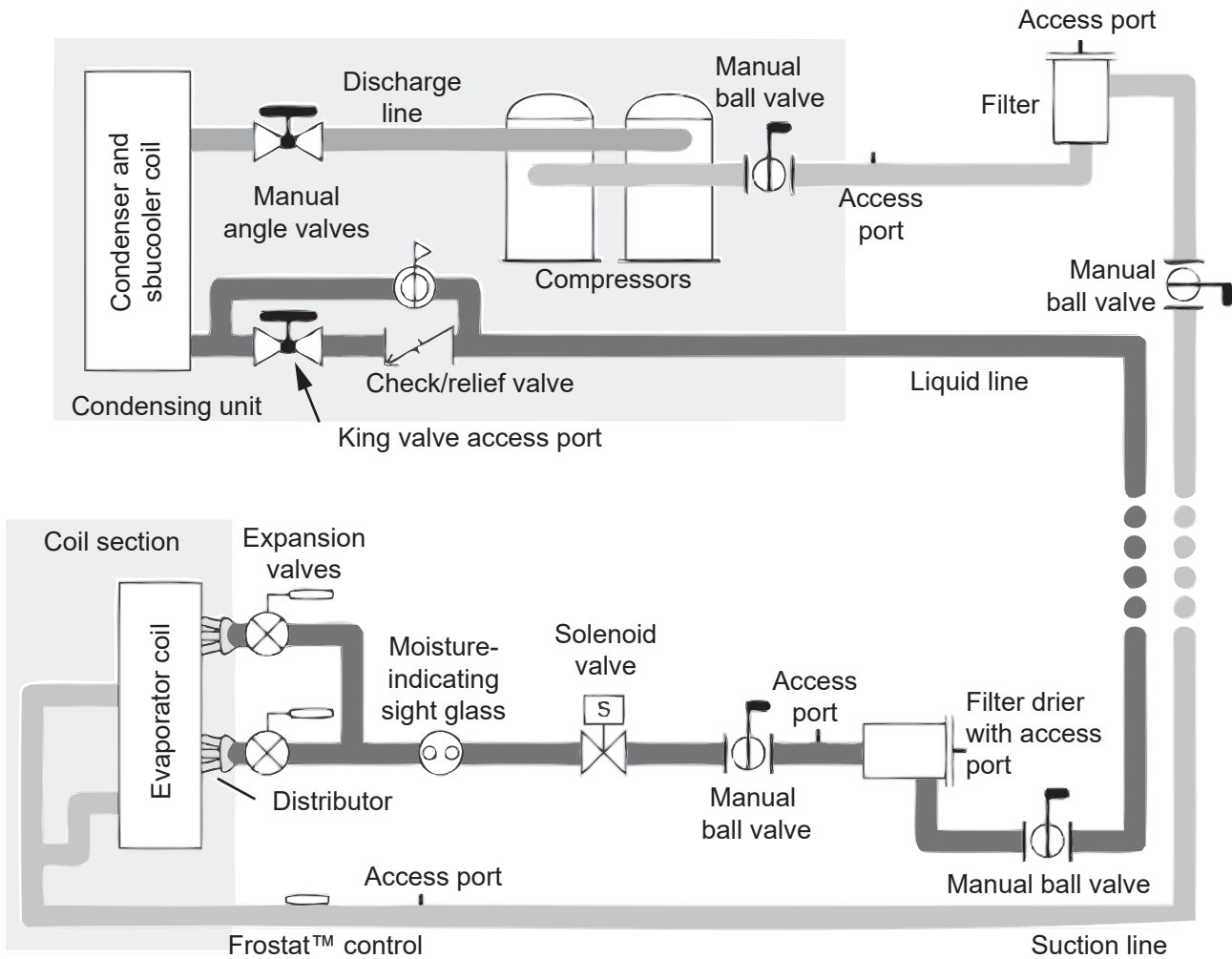

Kit with sensor - X13790452010 SEN-01212
 Kit with switch - X13100429010 THT 02442

Liquid Lines

Line Sizing

Properly sizing the liquid line is critical to a successful split system application. The selected tube diameter must provide at least 5°F [2.7°C] of subcooling at the expansion valve throughout the operating envelope. Increasing the size of the liquid line will not increase the available subcooling.

Routing

Install the liquid line with a slight slope in the direction of flow so that it can be routed with the suction line. Minimize tube bends and reducers because these items tend to increase pressure drop and to reduce subcooling at the expansion valve. Liquid line receivers, other than those that are factory-installed, are not recommended.

Insulation

The liquid line is generally warmer than the surrounding air, so it does not require insulation. In fact, heat loss from the liquid line improves system capacity because it provides additional subcooling. However, if the liquid line is routed through a high temperature area, such as an attic or a mechanical room, insulation would be required.

Components

Liquid-line refrigerant components necessary for a successful job include a filter drier, access port, solenoid valve, moisture indicating sight glass, expansion valve(s), and ball shutoff valves. Figure 133, p. 110 illustrates the proper sequence for positioning them in the liquid line. Position the components as close to the evaporator as possible.

- Filter drier: There is no substitute for cleanliness during system installation. The filter drier prevents residual

contaminants, introduced during installation, from entering the expansion valve and solenoid valve.

- Access port: The access port allows the unit to be charged with liquid refrigerant and is used to determine subcooling. This port is usually a Schraeder® valve with a core.
- Solenoid valve: In split systems, solenoid valves isolate the refrigerant from the evaporator during off cycles; under certain conditions, they may also trim the amount of active evaporator as compressors unload. Generally, the trim solenoid valve is unnecessary for VAV comfort-cooling applications, and is only required for constant-volume applications when dehumidification is a concern. In split systems with microchannel heat exchanger condensers (MCHE), solenoid valves isolate the refrigerant from the evaporator during the off cycles. Trim solenoids cannot be used with MCHE.

Note: Trane condensing units with MCHE no longer employ pump-down, but isolation solenoids are required. The suggested solenoid uses a 120-volt service and requires code-compliant wiring to the condensing unit.

- Moisture-indicating sight glass: Be sure to install one moisture-indicating sight glass in the main liquid line. The only value of the sight glass is its moisture indication ability.

Use actual measurements of temperature and pressure not the sight glass to determine subcooling and whether the system is properly charged. The moisture indicator/ sight glass must be sized to match the size of the liquid line at the thermal expansion valve.

NOTICE

Valve Damage!

Failure to protect the valve from high temperatures could result in damage to internal components.

Disassemble the thermal expansion valve before completing the brazing connections. If necessary, wrap the valve in a cool, wet cloth while brazing.

- Thermal expansion valve: The expansion valve is the throttling device that meters the refrigerant into the evaporator coil. Metering too much refrigerant floods the compressor; metering too little elevates the compressor temperature. Choosing the correct size and type of expansion valve is critical to assure it will correctly meter refrigerant into the evaporator coil throughout the entire operating envelope of the system. Correct refrigerant distribution into the coil requires an expansion valve for each distributor.

The thermal expansion valve must be selected for proper size and capacity. The size of the expansion valve should cover the full range of loadings. Check that the valve will successfully operate at the lightest load condition. For improved modulation,

choose expansion valves with balanced port construction and external equalization. Cut the process tube and cap assembly from the liquid connection as shown in Figure 134, p. 111 and install the expansion valve directly to the liquid connections.

Figure 134. Type F refrigerant coil with packed elbow

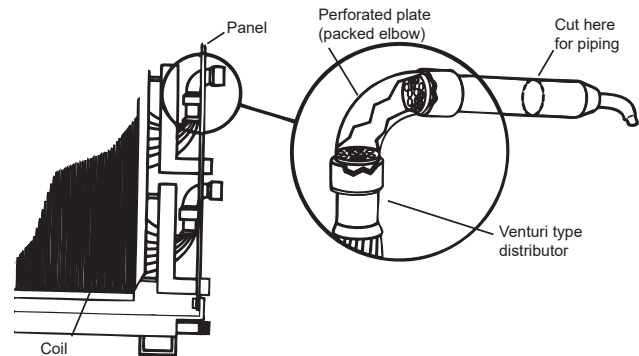

- Ball shutoff valves: Adding manual, ball-type shutoff valves upstream and downstream of the filter simplifies replacement of the filter core.

Suction Lines

Line sizing

Proper line sizing is required to guarantee the oil returns to the compressor throughout the systems operating envelope. At the same time, the line must be sized so that the pressure drop does not excessively affect capacity or efficiency. To accomplish both objectives, it may be necessary to use two different line diameters: one for the horizontal run and for the vertical drops, and another for the vertical lifts (risers).

Routing

To prevent residual or condensed refrigerant from free-flowing toward the compressor during the off cycle, install the suction line so it slopes by 1/4-inch to 1-inch per 10 feet of run toward the evaporator.

When the application includes a suction riser, oil must be forced to travel the height of the riser. Riser traps are unnecessary in the suction line. They will add pressure drop. Double risers must not be used. They not only add pressure drop, but can hold great amounts of oil better used in the compressor.

Note: If a suction riser is properly sized, oil will return to the compressor regardless of whether a trap is present. If a suction riser is oversized, adding a trap will not restore proper oil entrainment.

Avoid Underground Refrigerant Lines

Refrigerant condensation during the off cycle, installation debris inside the line (including condensed ambient

moisture), service access, and abrasion/corrosion can quickly impair reliability.

Insulation

Any heat that transfers from the surrounding air to the cooler suction lines increases the load on the condenser (reducing the systems air-conditioning capacity) and promotes condensate formation. After operating the system and testing all fittings and joints to verify that the system is leak-free, insulate suction lines to prevent heat gain and unwanted condensation.

Components

Installing the suction line requires field installation of these components: a filter, access port, and a Froststat™ control when the refrigerant coil is used with Trane condensing units. Position them as close to the compressor as possible.

Note: *Placement of the Froststat control is illustrated in Figure 133, p. 110.*

- **Filter:** The suction filter prevents contaminants, introduced during installation, from entering the compressor. For this reason, the suction filter should be the replaceable-core type, and a clean core should be installed after the system is cleaned up.
- **Access port:** The access port is used to determine suction pressure. This port is usually a Schraeder valve with a core.
- **Froststat coil frost protection:** The Froststat control is the preferred method for protecting evaporator coils from freezing when the refrigerant coil is used with Trane condensing units. It senses the suction-line temperature and temporarily disables mechanical cooling if it detects frost conditions. The control is mechanically attached to the outside of the refrigerant line, near the evaporator, and wired to the unit control panel.
- **Ball shutoff valve:** Adding manual, ball-type shutoff valves upstream and downstream of the filter simplifies replacement of the filter core.

Expansion Valves

Note: *Thermal expansion valve (TXV) is never provided or sized from the factory. This is always a field-sized and field-provided component.*

Expansion valves meter refrigerant into the evaporator under controlled conditions. If there is too much refrigerant, the refrigerant will not completely vaporize and the remaining liquid will slug the compressor. If there is too little refrigerant, there may not be enough cooling for the compressor.

Expansion valve requirements vary based on condensing unit design. Consult the product literature for the condensing unit to be used for proper valve selection.

Hot Gas Bypass

Many years ago, hot gas bypass (HGBP) was successfully added to HVAC systems to correct a number of operational problems. Hoping to avoid such problems altogether, it eventually became common practice for designers to specify hot gas bypass in new systems. Unfortunately, the practice often degraded rather than improved reliability.

Hot gas bypass increases the minimum refrigerant charge; it also inflates the first cost of the system. Besides adding more paths for potential refrigerant leaks, hot gas bypass increases the likelihood of refrigerant distribution problems. Finally, hot gas bypass uses excessive amounts of energy by preventing the compressors from cycling with fluctuating loads.

Trane now has many years of experience in the successful use of equipment without hot gas bypass in commercial comfort-cooling applications. To prevent evaporator freeze-up, Trane equipment typically includes Froststat™ coil frost protection.

Like hot gas bypass, the Froststat system protects the coil from freezing, but it does so by turning off compressors when a sensor detects the formation of frost on the evaporator coil. The compressor is released to operate when the coil temperature rises a few degrees above the frost threshold. The Froststat control strategy reduces the overall energy consumption of the system while maintaining system control.

Systems should be designed to avoid HGBP whenever possible. For more information about HGBP, see Engineers Newsletter, *Engineering Newsletter - blessing or curse? Hot Gas Bypass – Engineers Newsletter or Application Note (ADM-APN007*-EN)*.

Humidifier Piping and Connections

These instructions cover the piping installation for Trane building steam humidifier panel and atmospheric steam humidifier panel. The humidifier panel shall arrive installed in the unit air cabinet.

Units with a humidifier panel to be used with building (boiler) steam will also receive the following piping accessories shipped direct from the humidifier vendor to the jobsite address.

- Inverted bucket steam trap (to be used to drip steam supply to control valve)
- Control valve
- In-line Y strainer (to be used prior to the control valve)
- Float and thermostatic steam trap (for condensate drainage of header, two required)

Units with a humidifier panel to be used with atmospheric distribution of steam generated by electric or steam-to-steam humidifiers (steam generating) are not supplied with piping accessories. Piping will be determined by requirement of field-provided steam generator.

All accessories listed above will be on the packing slip. Report any shortages immediately. If accessories have been damaged in transit, notify Trane and file claim with the transportation company. If your order covers more than one package, segregate complete assembly. Equipment tagging will be the same as shown on the packing list.

All piping accessories should be installed in accordance with all applicable building, plumbing, and electrical codes.

Condensate discharged from the humidifier separator/header is essentially atmospheric pressure. Thus condensate must be discharged to a drain or pumped. On many applications, an attempt to lift condensate even a few inches will lead to potential flooding or spitting problems from the multiple tube bank. Avoid combined trapping of the two connections into one steam trap. If traps discharge into a common return, install check valves (low opening pressure) on the outlet of each trap.

Supplying quality steam (not wet) to the humidifier panel is an important component for proper operation. Care must be taken that the main supply header is dripped sufficiently as well as the runout piping to the control valve and header. The entire system must be designed and hooked up to prevent accumulation of condensate at any point. The following recommendations will help to ensure this.

Use drip legs and traps at all low spots or natural drainage points such as:

- Ahead of risers
- End of mains
- Ahead of expansion joints or bends
- Ahead of valves or regulators

Install drip legs and drain traps even where there are no natural drainage points.

Figure 135. Building (boiler) steam panel piping

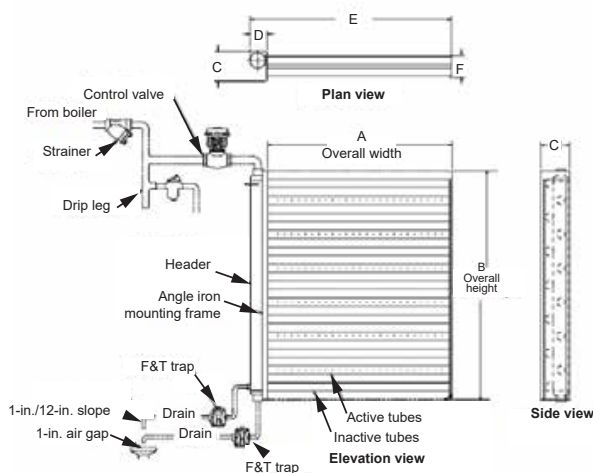

Note: Unit drain pan and connection not shown.

Remodel, Retrofit, or Replacement

Inevitably, older condensing units and evaporator systems will need to be replaced or retrofitted. Due to the phase-out of many of these older refrigerants, the major components for those older units or systems may no longer be available. The only option will be to convert the system to R-410A, POE oil, and R-410A components.

When upgrading an existing refrigerant split system due to remodel, retrofit, or replacement, the entire system must be reviewed for compatibility with R-410A and POE oil. Each and every part of the split HVAC system MUST be compatible with the properties of R-410A refrigerant and POE oil. In addition, ensure the existing electrical service is adequate for the product being installed.

⚠ WARNING

R-410A Refrigerant under Higher Pressure than R-22!

Failure to use proper equipment or components as described below, could result in equipment failing and possibly exploding, which could result in death, serious injury, or equipment damage.

The units described in this manual use R-410A refrigerant which operates at higher pressures than R-22. Use ONLY R-410A rated service equipment or components with these units. For specific handling concerns with R-410A, please contact your local Trane representative.

Every part of an existing split system needs to be analyzed to determine if it can be reused in an R-410A and POE oil system:

- R-22 condensing units will not work with R-410A; they must be replaced.
- Most older evaporator coils were not pressure- and cyclered for R-410A pressures. If they weren't, they will need to be replaced. If they were properly pressure-rated for R-410A, existing coils must be modeled to determine if they will meet capacity requirements, are properly circuited, have correctly sized distributor tubes, and employ acceptable distributors and orifices.
- The required R-410A line sizes may be different than the existing line sizes. The lines need to be re-sized and compared to existing lines for reusability.
- Suction lines 2-5/8 OD and smaller of type L copper are suitable for use with R-410A. Suction lines 3-1/8 OD must use type K or thicker wall.
- Discharge lines, liquid lines, heat pump vapor lines, and hot gas bypass lines 1-3/8 OD and smaller of type L copper are suitable for use with R-410A. These same lines sized at 1-5/8 OD or 2-1/8 OD must use type K or thicker wall.
- Expansion valves need to be reselected. Expansion valves are refrigerant specific.

Piping and Connections

- Any gasket or O-ring should be replaced. Shrinkage of the original seal may occur after an HFC conversion, potentially causing a refrigerant leak. Components commonly affected are Schraeder cores, solenoid valves, ball valves, and flange seals. But all external seals in contact with refrigerant should be viewed as potential leak sources after a retrofit.
- All other valves, filters, valve packing, pressure controls, and refrigeration accessories must be researched through their manufacturer for compatibility with the pressures of an R-410A system, and for their compatibility with the newer POE oil.
- For the best performance and operation, the original mineral oil should be removed from the components of the system that are not being replaced. Any component of the system that is suspected of trapping oil (piping, traps, and coil), should be dismantled, drained, and reassembled. After all components have been drained, the amount of residual mineral oil will have a negligible effect on performance and reliability

NOTICE

Compressor Damage!

POE oil is hygroscopic – it absorbs water directly from the air. This water is nearly impossible to remove from the compressor oil and can result in compressor failures.

To prevent POE oil from absorbing water, the system should not remain open for longer than necessary. When open, dry nitrogen should flow through the piping. Only new oil containers should be used for service and maintenance. Always use the smallest container size required for the job requirements. Always leave the oil container tightly sealed until time of use. Do not reuse oil that has been opened.

All Codes take precedence over anything written here.

Field-Installed Evaporator Piping

Figure 136. Typical single-circuit condensing unit: evaporator coil with one distributor

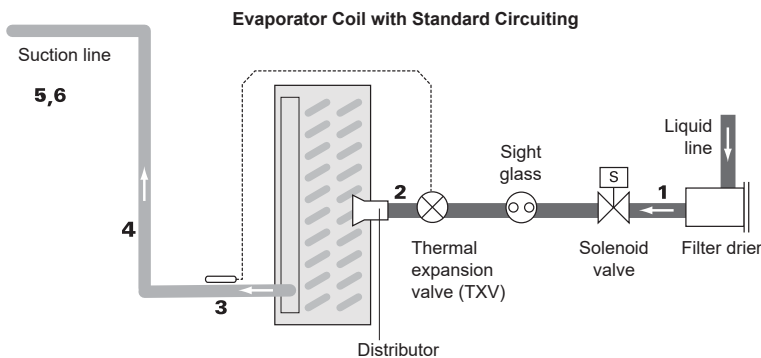

1. Pitch the liquid line slightly –1 inch/10 feet – so that the refrigerant drains toward the evaporator.
2. Provide one expansion valve per distributor.
3. Slightly pitch the outlet line from the suction header toward the suction riser – that is, 1 inch/10 feet in the direction of flow. Use the tube diameter that matches the suction header connection.
4. Use the tube diameter recommended in the condensing unit application manual for a vertical rise. Ensure that the top of the riser is higher than the evaporator coil
5. Pitch the suction line slightly – 1 inch/10 feet – so the refrigerant drains toward the evaporator.
6. Insulate the suction line.

Figure 137. Typical single-circuit condensing unit: evaporator coil with two distributors

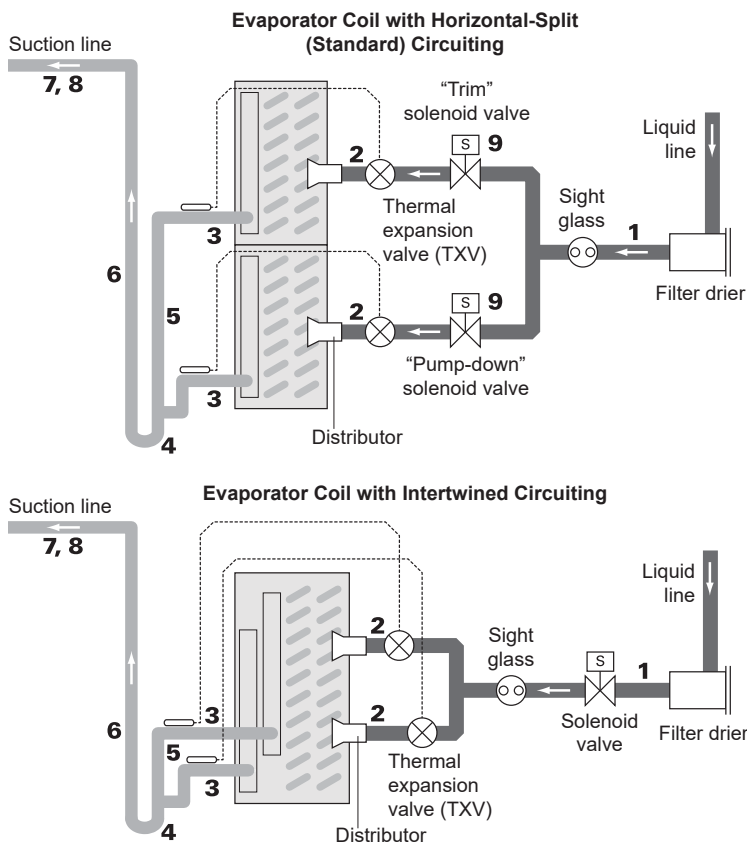

1. Pitch the liquid line slightly – 1 inch/10 feet – so the refrigerant drains toward the evaporator.
2. Provide one expansion valve per distributor.
3. Slightly pitch the outlet line from the suction header toward the suction riser – 1 inch/10 feet in the direction of flow. Use the tube diameter that matches the suction-header connection. Use a double-elbow configuration to isolate the TXV bulb from other suction headers.
4. This looks like a trap, but is actually due to the requirement that the refrigerant gas leaving the coil flows downward, past the lowest suction-header outlet, before turning upward.
5. Use the **horizontal** tube diameter as specified in the condensing unit application manual.
6. Use the tube diameter recommended for a vertical rise as specified in the condensing unit application manual. Assure the top of the riser is higher than the evaporator coil.
7. Pitch the suction line slightly – 1 inch/10 feet – so that the refrigerant drains toward the evaporator.
8. Insulate the suction line.
9. Only use a **trim** solenoid valve for constant volume, humidity-sensitive applications. For all other applications, install a single solenoid valve (the **pumpdown** solenoid valve) between the liquid-line filter drier and the sight glass.

Note: Due to reduced coil volume in condensing units with microchannel heat exchanger condenser, do not use trim solenoid valves for these units.

Figure 138. Typical single-circuit condensing unit: evaporator coil with four distributors

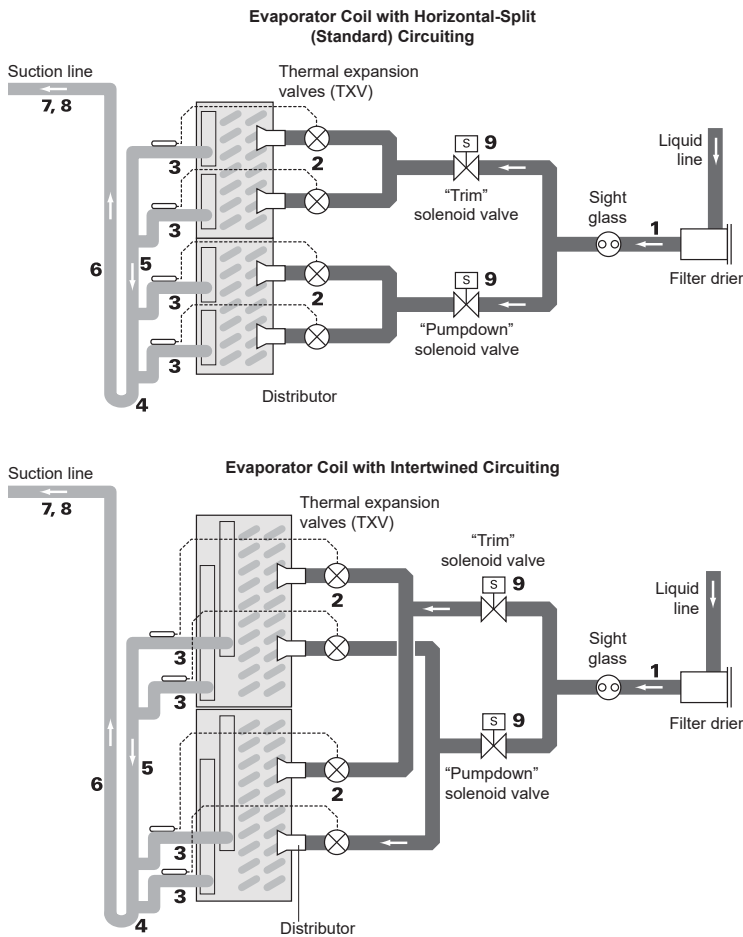

1. Pitch the liquid line slightly – 1 in./10 feet – so that the refrigerant drains toward the evaporator.
2. Provide one expansion valve per distributor.
3. Slightly pitch the outlet line from the suction header toward the suction riser – 1 in./10 feet in the direction of flow. Use the tube diameter that matches the suction-header connection.
4. This looks like a trap, but is actually due to the requirement that the refrigerant gas leaving the coil flows downward, past the lowest suction-header outlet, before turning upward. Use the double-elbow configuration to isolate the TXV bulb from other suction headers.
5. Use the **horizontal** tube diameter as specified in the condensing unit application manual.
6. Use the tube diameter recommended for a vertical rise as specified in the condensing unit application manual. Ensure that the top of the riser is higher than the evaporator coil.
7. Pitch the suction line slightly – 1 in./10 feet – so that the refrigerant drains toward the evaporator.
8. Insulate the suction line.
9. Only use a **trim** solenoid valve for constant volume, humidity-sensitive applications. For all other applications, install a single solenoid valve (the **pumpdown** solenoid valve) between the liquid-line filter drier and the sight glass.

Note: Due to reduced coil volume in condensing units with microchannel heat exchanger condenser, do not use trim solenoid valves for these units.

Figure 139. Typical dual-circuit condensing unit: evaporator coil with two distributors

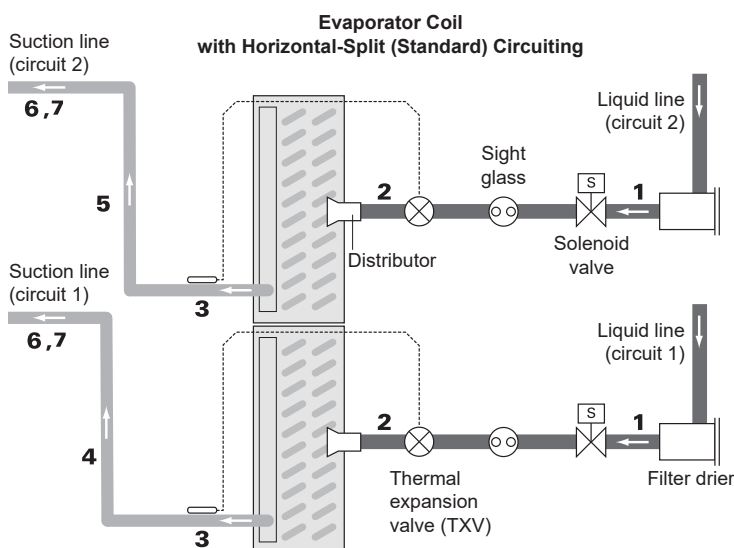

1. Pitch the liquid lines slightly – 1 in./10 feet – so that the refrigerant drains toward the evaporator.
2. Provide one expansion valve per distributor.
3. Slightly pitch the outlet line from the suction header toward the suction riser – 1 in./10 feet in the direction of flow. Use the tube diameter that matches the suction-header connection.
4. The top of the Circuit 1 suction riser must be higher than the bottom evaporator coil. Use the tube diameter recommended for a vertical rise as specified in the condensing unit application manual.
5. The top of the Circuit 2 suction riser must be higher than the top evaporator coil. Use the tube diameter recommended for a vertical rise as specified in the condensing unit application manual.
6. Pitch the suction lines slightly – 1 in./10 feet – so that the refrigerant drains toward the evaporator.
7. Insulate the suction lines.

Figure 140. Typical dual-circuit condensing unit: evaporator coil with four distributors

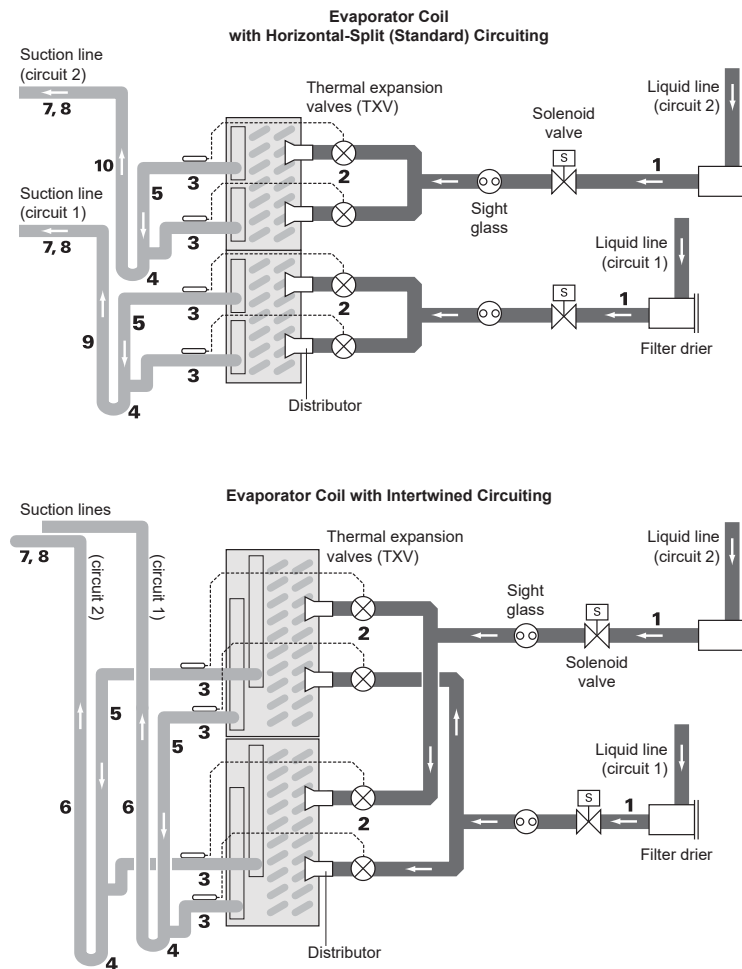

1. Pitch the liquid line slightly – 1 in./10 feet – so that the refrigerant drains toward the evaporator.
2. Provide one expansion valve per distributor.
3. Slightly pitch the outlet line from the suction header toward the suction riser – 1 in./10 feet in the direction of flow. Use the tube diameter that matches the suction-header connection.
4. This looks like a drain trap, but is actually due to the requirement that the refrigerant gas leaving the coil flows downward, past the lowest suction-header outlet, before turning upward. Use the double-elbow configuration to isolate the TXV bulb from other suction headers.
5. Use the **horizontal** tube diameter as specified in the condensing unit application manual.
6. Use the tube diameter recommended for a vertical rise as specified in the condensing unit application manual. Ensure that the top of the riser is higher than the evaporator coil.
7. Pitch the suction line slightly – 1 in./10 feet – so that the refrigerant drains toward the evaporator.
8. Insulate the suction line.
9. The top of the Circuit 1 suction riser must be higher than the bottom evaporator coil. Use the tube diameter recommended for a vertical rise as specified in the condensing unit application manual.
10. The top of the Circuit 2 suction riser must be higher than the top evaporator coil. Use the tube diameter recommended for a vertical rise as specified in the condensing unit application manual.

Figure 141. Typical dual-circuit condensing unit: evaporator coil with eight distributors

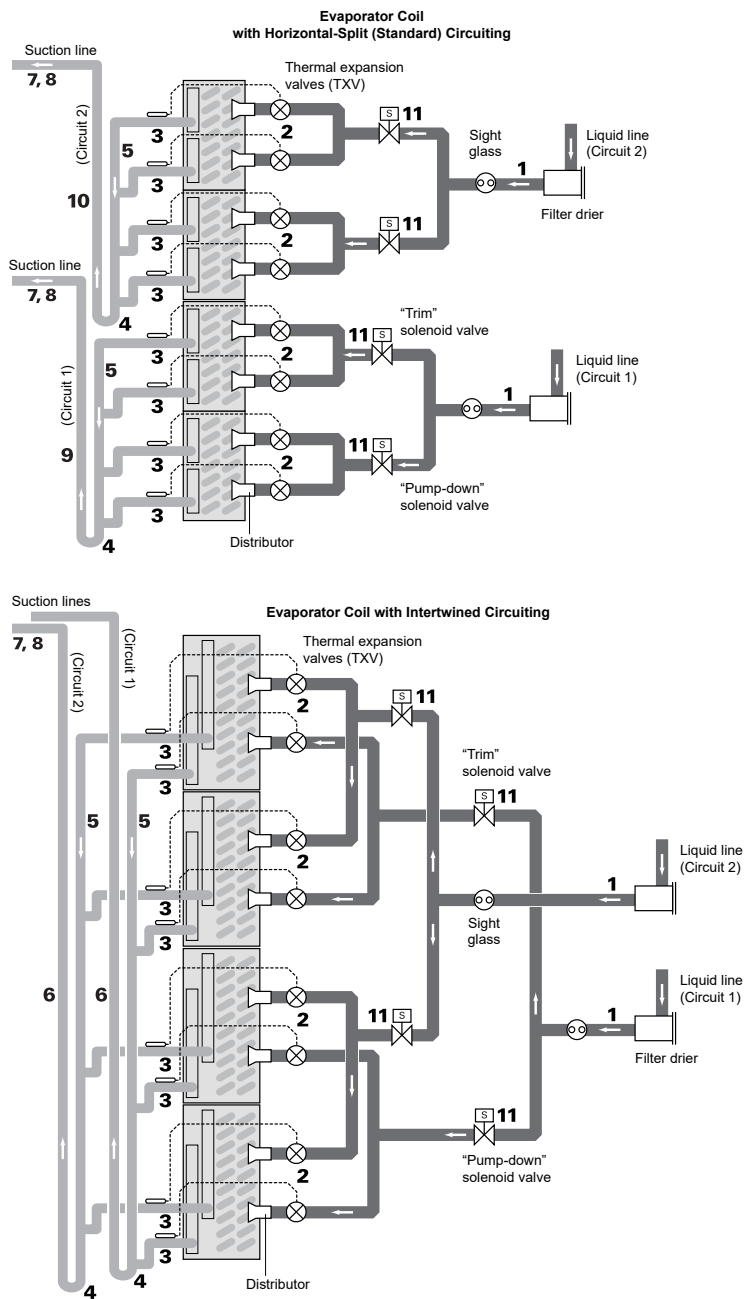

1. Pitch the liquid line slightly – 1 inch/10 feet – so that the refrigerant drains toward the evaporator.
2. Provide one expansion valve per distributor.
3. Slightly pitch the outlet line from the suction header toward the suction riser – 1 in./10 feet in the direction of flow. Use the tube diameter that matches the suction-header connection.
4. This looks like a drain trap, but is actually due to the requirement that the refrigerant gas leaving the coil flows downward, past the lowest suction-header outlet, before turning upward. Use the double-elbow configuration to isolate the TXV bulb from other suction headers.
5. Use the **horizontal** tube diameter as specified in the condensing unit application manual.
6. Use the tube diameter recommended for a vertical rise as specified in the condensing unit application manual. Confirm that the top of the riser is higher than the evaporator coil.
7. Pitch the suction line slightly – 1 in./10 feet – so that the refrigerant drains toward the evaporator.
8. Insulate the suction line.
9. The top of the Circuit 1 suction riser must be higher than the bottom evaporator coil. Use the tube diameter recommended for a vertical rise as specified in the condensing unit application manual.
10. The top of the Circuit 2 suction riser must be higher than the top evaporator coil. Use the tube diameter recommended for a vertical rise as specified in the condensing unit application manual.
11. Only use a **trim** solenoid valve for constant volume, humidity-sensitive applications. For all other applications, install a single solenoid valve (the **pumpdown** solenoid valve) between the liquid-line filter drier and the sight glass.

Note: Due to reduced coil volume in condensing units with microchannel heat exchanger condenser, do not use trim solenoid valves for these units.

Installation - Electrical

⚠ WARNING

Hazardous Voltage w/Capacitors!

Failure to disconnect power and discharge capacitors before servicing could result in death or serious injury.

Disconnect all electric power, including remote disconnects and discharge all motor start/run capacitors before servicing. Follow proper lockout/tagout procedures to ensure the power cannot be inadvertently energized. For variable frequency drives or other energy storing components provided by Trane or others, refer to the appropriate manufacturer's literature for allowable waiting periods for discharge of capacitors. Verify with a CAT III or IV voltmeter rated per NFPA 70E that all capacitors have discharged.

NOTICE

Use Copper Conductors Only!

Failure to use copper conductors could result in equipment damage as the equipment was not designed or qualified to accept other types of conductors.

⚠ WARNING

Electrical Shock Hazard!

Failure to follow instructions below could result in death or serious injury.

Properly connect the system's oversized protective earthing (grounding) terminal(s).

Note: Air handlers often include optional factory-provided casing penetration entry points for field-provided wiring. Consider overall unit serviceability and accessibility before mounting, running wires (power), making cabinet penetrations, or mounting any components to the cabinet.

The electric heat door may have a solenoid locking mechanism to prevent opening the control panel while the electric heater is energized.

Units intended for indoor use are available with starters or variable-frequency drives (VFDs) that are externally mounted in an enclosure or internally mounted in a recessed cabinet. Units intended for outdoor use are only available with internally mounted starters or VFDs. A typical internally mounted VFD is shown in the following figure.

Figure 142. Internally mounted VFD



A typical externally mounted VFD is shown the following figure.

Figure 143. Externally mounted VFD



Motorized Impeller Control Panel

Motorized impeller control panel (MICP) is mounted in an external NEMA 3R box and provides a common externally accessible disconnect switch, power distribution block, control terminal block, and independent motor over current protection. Motor control connections are brought to the external enclosure to ease field wiring. This option allows the fan to be included in a unit single-point power feed and allows the control signals to be pre-wired into the factory installed control system. Manual control via an enclosure mounted dial is available with the motorized impeller control panel with handoff- auto switch. Refer to the following figure for control panel layout of the three fan configurations.

The control panels disconnect handle requires that the panel be mounted 72-inches or below from the floor. This limits the option to fan sections on the bottom level of the unit or fan sections on the second level for units size 14 and below. For fan quantities greater than 3, the disconnect switch is replaced by a circuit breaker. With the hand-off-auto feature, a circuit breaker is used for all fan quantities.

Figure 144. External motorized impeller control panel (MICP)



Motorized Impeller Control Panel with Hand Off Auto Switch

Typical wiring schematics for VFDs and starters are shown in [Figure 151, p. 123](#) and [Figure 154, p. 126](#), respectively. Unit specific wiring schematics are shipped with each unit.

All units with starters or VFDs that have direct-digital controllers (DDCs) are provided with line voltage to 24 Vac power transformers as shown in [Figure 145, p. 120](#).

Figure 145. Controller - internally mounted



When provided, the line voltage to 24 Vac transformers are factory wired to the supply fan power feed. All units with factory-mounted controllers, and no starters or VFDs, are provided with 120 Vac to 24 Vac control transformers, as shown in [Figure 146, p. 120](#), and require a separate 120V field connection.

Figure 146. Controller - externally mounted



Figure 147. Externally mounted control box

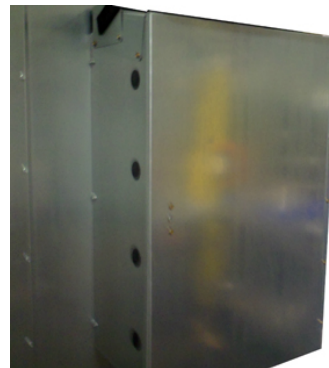

As with starters or VFDs, units intended for indoor use are available with DDCs mounted internally (see [Figure 145, p. 120](#)) or externally (see [Figure 146, p. 120](#) and [Figure 147, p. 120](#)), while units intended for outdoor use are only available with internally mounted DDCs.

In units with 24 Vac LED marine lights, the lights are wired together to a single switch located in the controls interface module. [Figure 147, p. 120](#) shows a typical mounting of the controls interface module with an externally mounted controller. When DDCs are provided, the lighting circuit is powered from the DDC power feed and does not require a separate power source. When marine lights are provided without DDCs, the lighting circuit requires a separate 120V field connection that powers the lights through a 120V to 24 Vac power transformer.

A mounted GFCI receptacle is provided for all units that have DDCs or marine lights. The receptacle is mounted in the controls interface module (see [Figure 147, p. 120](#)) with the unit light switch. The receptacle requires a separate 120V power feed.

The electric heat door may have a solenoid locking mechanism to prevent opening the control panel while the electric heater is energized.

Field installed DDC control devices:

- Install outside-air sensor and space sensor, if ordered.
- Connect control valves, if ordered, to the valve jack provided as part of the unit wiring harness. The valve jack is typically located at the air-leaving side of the coil connection inside the casing panel. For valve junction box mounting and wiring detail, see [Figure 148, p. 121](#).

Figure 148. Junction box for valve wiring

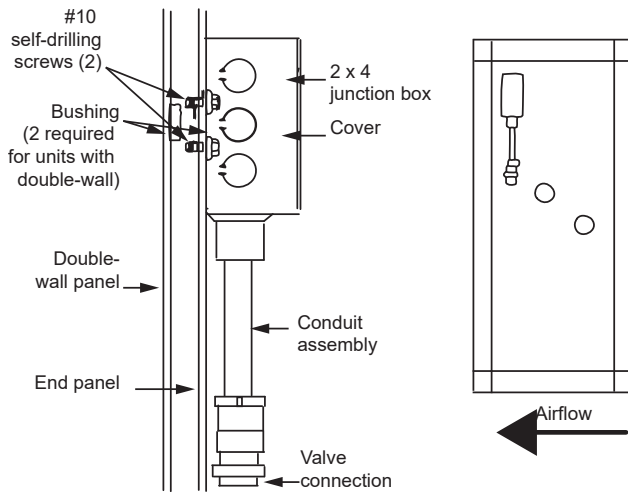

The installer must also furnish a service disconnect switch in compliance with national and local electrical codes.

Fan motors require motor overload protective devices that are rated or selected in compliance with the National Electric Code (NEC) or Canadian Electric Code. Specific unit and motor connection diagrams are provided on the starter/VFD if Trane-provided, or refer to the motor nameplate.

If wiring directly to the motor, a flexible connection at the motor to permit fan belt adjustment should be provided. Fractional horsepower motors may be factory connected to a terminal box on the unit. If this construction is provided, the installer should complete field wiring to this connection box. For a typical wiring schematic, see [Figure 151, p. 123](#) thru [Figure 158, p. 130](#).

Note: Properly seal all penetrations in unit casing. Failure to seal penetrations from inner panel to outer panel could result in unconditioned air entering the unit.

CDQ™ Desiccant Wheel Cassette/Motor

NOTICE

Energy Wheel Motor Failure!

Failure to follow instructions below could result in failure of the energy wheel motor
Do not install a variable frequency drive (VFD) to control the energy wheel speed.

If not factory-installed, the electrical contractor must provide and install a starter or starting contactor, disconnect, fuses, etc., as required by local codes, for the CDQ wheel motor. Do not install a variable frequency drive (VFD) to control the desiccant wheel speed. This may result in failure of the wheel motor. The motor requires air movement for continuous operation. Operating the wheel for long periods with the fan off may result in motor failure.

Quick Connects

The actuators, factory-mounted or field-supplied, are separately wired and controlled by a direct-digital controller or other building logic. [Figure 149, p. 121](#) illustrates the typical quick connect scheme.

Note: With units that require splits to be assembled that have high voltage quick connects, use wire ties to bind the quick connections together to avoid poor connections or intermittent connection from vibrations.

Figure 149. Typical quick connects with wiring

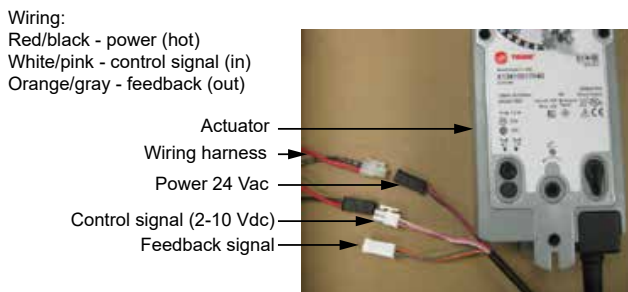

If the unit does not include a factory-mounted starter, wiring to the unit fan motor must be provided by the installer and must comply with all national and local electrical codes.

Optional Damper Actuators

Each actuator requires 24 Vac supply power and wiring for the 2–10 Vdc control signal. This wiring should be sized and installed as required per national and local electrical codes.

Optional Air Temperature Sensors

If not factory-wired, connection to the air temperature sensors is made by penetrating through the side of the module wall and making electrical connections to the temperature sensor. Nominal resistance of these sensors is 1,000 ohms at 32°F (0°C). The sensor is a thermistor with a platinum 375 resistance curve. This wiring should be sized and installed as required per national and local electrical codes.

Table 35. CDQ motor data

Wheel Size (nominal cfm)	HP	Voltage/phase	HZ	Full Load Amps	Rotation RPM	Rotation Direction
500-5000	1/80	115 Volt Single Phase	60	0.3	2.30	CW/CCW*
6000-40,000	1/80	115 Volt Single Phase	60	0.3	4.50	CW/CCW*

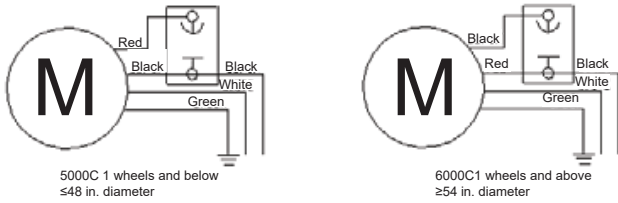
Figure 150. CDQ motor wiring

Typical Wiring Schematics

Figure 151. Typical schematic for VFD with bypass wiring

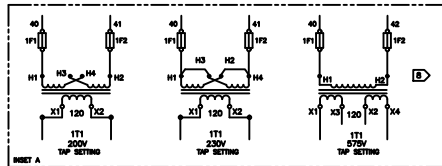
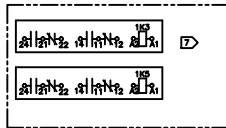
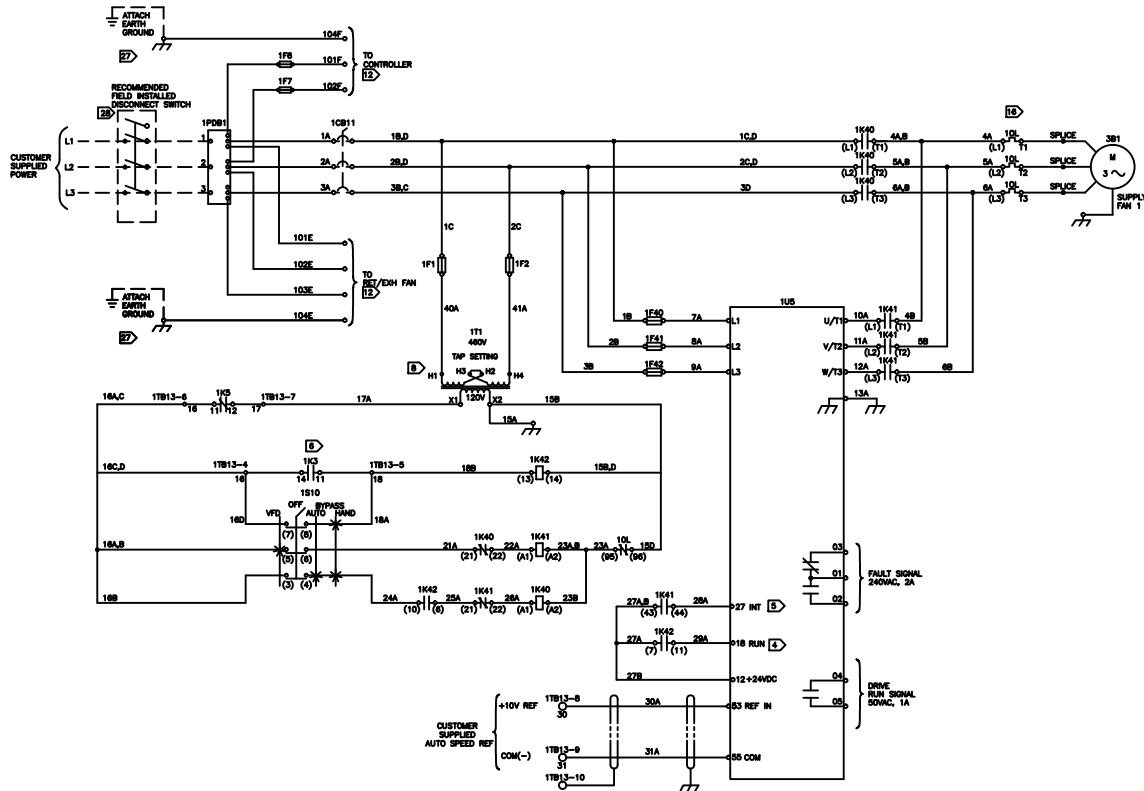

NOTES:

- 1 DASHED LINES INDICATE RECOMMENDED FIELD WIRING BY OTHERS. PHANTOM LINES INDICATE CONTROL OPTION. REF. CONTROL PANEL SCHEMATIC FOR SPECIFIC DETAIL.
- 2 ALL FIELD WIRING MUST BE IN ACCORDANCE WITH THE NATIONAL ELECTRICAL CODE (NEC), STATE AND LOCAL REQUIREMENTS. OTHER COUNTRIES APPLICABLE NATIONAL AND/OR LOCAL REQUIREMENTS SHALL APPLY. FIELD CONDUCTORS SHALL HAVE INSULATION RATING NOT LESS THAN 90°C COPPER CONDUCTORS ONLY.
- 3 THE MINIMUM CIRCUIT AMPACITY, THE MAXIMUM FUSE SIZE, AND DISCONNECT SIZE ARE CALCULATED BASED ON THE INVERTER INPUT LINE CURRENTS PER ARTICLE 430-2 OF THE NATIONAL ELECTRICAL CODE.
- 4 PROGRAM TERMINAL 18 AS RUN.
- 5 PROGRAM TERMINAL 27 INV. COASTING STOP.
- 6 CLOSURE TO RUN AUTO MODE OR BYPASS AUTO FOR OPTION VFD OR STARTER.
- 7 RELAY(S)—INDUCTIVE LOAD: 1/8 HP @ 240VAC. RESISTIVE LOAD: 5A @ 240VAC. SEE SCHEMATIC DIAGRAM FOR COIL CONNECTIONS AND ACTUAL QUANTITY OF TRANSFORMER RELAYS.
- 8 CONTROL TRANSFORMER SHOWN FOR 480V PRIMARY. FOR 200V OR 230V OR 575V REFER TO INSET A.
- 12 IF LIFT HAS SHIPPING SPLITS WIRING WILL TERMINATE TO MODULE AT EACH SHIPPING SPLIT.
- 18 THE OVERLOAD RELAY TRIP SETTING MUST BE ADJUSTED TO CORRESPOND WITH THE MOTOR FULL LOAD CURRENT AS SHOWN ON THE MOTOR NAMEPLATE.
- 27 ATTACH GROUND OR EQUIPMENT GROUND.
- 28 CUSTOMER SUPPLIED LOCKABLE DISCONNECTING MEANS, SUCH AS A DISCONNECT SWITCH OR CIRCUIT BREAKER, INSTALLED LOCAL TO UNIT. SIZE AND PLACEMENT OF DEVICE SHALL BE DONE IN ACCORDANCE WITH APPLICABLE NATIONAL AND LOCAL ELECTRICAL CODES.

FUSE	VOLTAGE	VFD FUSES	CONTRIBUTOR FUSE (CLASS CC)
		PANEL HP P/N CLASS	FUSE VOLTAGE P/N
200/230	1F40 1F41 1F42	0.5-2 LP-CC-10 CC	1F8 200/230
		1 LP-CC-10 CC	1F7 200/230 KLDK-15
		3 LP-CC-10 CC	
		7.5-10 JAS-200 T	
		15 JAS-200 T	
		30 JAS-200 T	
		60 REC-200A	
		100 REC-200A	
		150 REC-200A	
		200 REC-200A	
200		0.5-2 LP-CC-10 CC	
		1 LP-CC-10 CC	
		3 LP-CC-10 CC	
		7.5-10 JAS-200 T	
		15 JAS-200 T	
		30 JAS-200 T	
		60 REC-200A	
		100 REC-200A	
		150 REC-200A	
		200 REC-200A	
230		0.5-2 LP-CC-10 CC	
		1 LP-CC-10 CC	
		3 LP-CC-10 CC	
		7.5-10 JAS-200 T	
		15 JAS-200 T	
		30 JAS-200 T	
		60 REC-200A	
		100 REC-200A	
		150 REC-200A	
		200 REC-200A	
480		0.5-2 LP-CC-10 CC	
		1 LP-CC-10 CC	
		3 LP-CC-10 CC	
		7.5-10 JAS-200 T	
		15 JAS-200 T	
		30 JAS-200 T	
		60 REC-200A	
		100 REC-200A	
		150 REC-200A	
		200 REC-200A	
575		0.5-2 LP-CC-10 CC	
		1 LP-CC-10 CC	
		3 LP-CC-10 CC	
		7.5-10 JAS-200 T	
		15 JAS-200 T	
		30 JAS-200 T	
		60 REC-200A	
		100 REC-200A	
		150 REC-200A	
		200 REC-200A	

DEVICE DESIGNATION	CIRCUIT DESCRIPTION
10B1	CIRCUIT BREAKER
1F1 TO 1F2	PRIMARY CONTROL TRANSFORMER FUSES
1F8 / 1F7	PRIMARY CONTROLLER FUSE
1F40 TO 1F42	VFD FUSES
1N3	START/STOP RELAY
1N3	LOW LIMIT RELAY
1K40	BYPASS CONTACTOR
1K41	ISOLATION CONTACTOR
1K42	RUN PERMISSIVE RELAY
1EL	OVERLOAD RELAY
1PDB1	POWER DISTRIBUTION BLOCK
1S10	VFD/OFF/BYPASS AUTO/BYPASS HAND SWITCH
1T1	PRIMARY CONTROL TRANSFORMER
1TB13	TERMINAL STOP CONTROL CIRCUIT
1US	VFD CONTROLLER
3B1	MOTOR 1



Installation - Electrical

Figure 152. Typical schematic for multi-VFD wiring

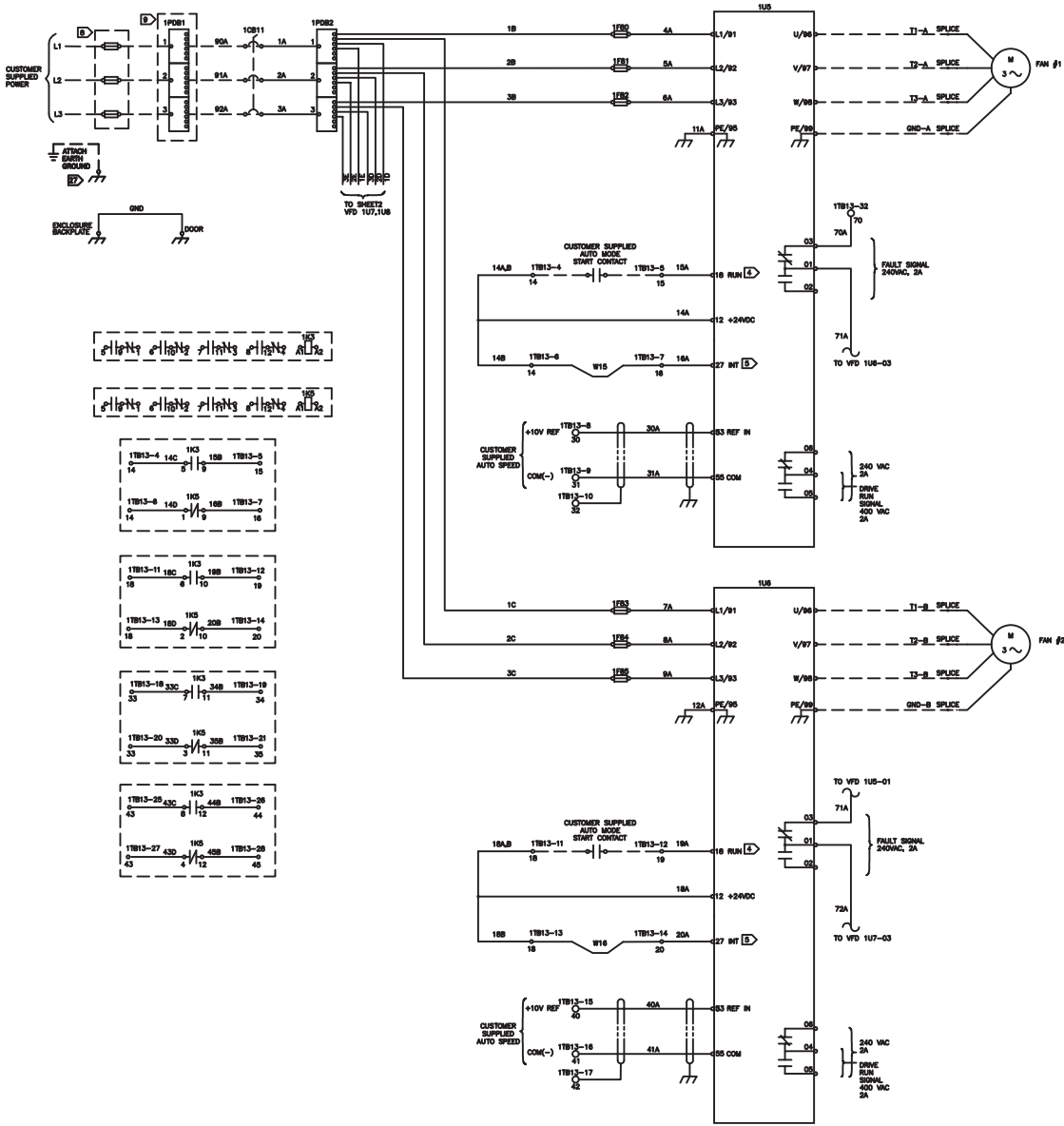

FUSE	VOLTAGE	VFD TRIP	P/N	CLASS	
200	480	150	11	COMBIO	00
			12	COMBIO	00
			13	COMBIO	00
230	480	150	11	COMBIO	00
			12	COMBIO	00
			13	COMBIO	00
480	480	150	11	COMBIO	00
			12	COMBIO	00
			13	COMBIO	00
675	480	150	11	COMBIO	00
			12	COMBIO	00
			13	COMBIO	00

- NOTES:**
- DASHED LINES INDICATE RECOMMENDED FIELD WIRING BY OTHERS. PHANTOM LINES INDICATE CONTROL OPTION. REF. CONTROL PANEL SCHEMATIC FOR SPECIFIC DETAIL.
 - ALL FIELD WIRING MUST BE IN ACCORDANCE WITH THE NATIONAL ELECTRICAL CODE, STATE, AND LOCAL REQUIREMENTS. OTHER COUNTRIES APPLICABLE NATIONAL AND/OR LOCAL REQUIREMENTS SHALL APPLY. FIELD CONDUCTORS SHALL HAVE INSULATION RATING NOT LESS THAN 600V COPPER CONDUCTORS ONLY.
 - MINIMUM CIRCUIT AMPACITY, MINIMUM FUSE SIZE, AND DISCONNECT SIZE ARE CALCULATED BASED ON THE INVERTER INPUT LINE CURRENTS PER ARTICLE 430-2 OF THE NATIONAL ELECTRICAL CODE.
 - PROGRAM TERMINAL 18 AS RUN.
 - PROGRAM TERMINAL 27 INV. COASTING STOP.
 - CLOSES TO RUN AUTO MODE OR BYPASS AUTO FOR OPTION VFD OR STARTER.
 - RELAYS—CONTACTS SILVER—COPPER ON ONE 1/8 HP AMP @ 120V AC 1/3 HP AMP @60V AC. SEE 24V SCHEMATIC DIAGRAM FOR COIL CONNECTIONS AND ACTUAL QUANTITY OF TRANSFORMER RELAYS.
 - CUSTOMER SUPPLIED DEVICES SUCH AS FUSEBREAKER.
 - OPTIONAL FRAME POWER DISTRIBUTION BLOCK.
 - ATTACH GROUND OR EQUIPMENT GROUND.
 - AIRFLOW SWITCH INPUT, REFER TO LOW VOLTAGE SCHEMATIC.

DEVICE DERIVATION	LEGEND	DESCRIPTION
10F11	10F11	CIRCUIT BREAKER
1F80 TO 1F81	1F80	VFD FUSES
1F82	1F82	POWER DISTRIBUTION BLOCK
17B13	17B13	TERMINAL STOP CONTROL CIRCUIT
11B	11B	VFD CONTROLLER 1
12B	12B	VFD CONTROLLER 2
13B	13B	VFD CONTROLLER 3
11A	11A	VFD CONTROLLER 1
12A	12A	VFD CONTROLLER 2
13A	13A	VFD CONTROLLER 3
1K3	1K3	START / STOP RELAY
1K5	1K5	LOW LIMIT RELAY

WARNING
HAZARDOUS VOLTAGE!

DISCONNECT ALL ELECTRIC POWER INCLUDING REMOTE DISCONNECTS AND FOLLOW LOCK OUT AND TAG PROCEDURES BEFORE SERVICING. ENSURE THAT ALL MOTOR CAPACITORS HAVE DISCHARGED STORED VOLTAGE. UNITS WITH VARIABLE SPEED DRIVE REFER TO DRIVE INSTRUCTIONS FOR CAPACITOR DISCHARGE. FAILURE TO DO THE ABOVE BEFORE SERVICING COULD RESULT IN DEATH OR SERIOUS INJURY.

AVERTISSEMENT
TENSION DANGEREUSE!

COUPER TOUTES LES TENSIONS ET OUBLIER LES DISCONNECTS A DISTANCE. PLUS SUIVRE LES PROCEDURES DE VERROUILLAGE ET DES ETIQUETTES AVANT TOUTE INTERVENTION. VÉRIFIER QUE TOUTS LES CONDENSATEURS DES MOTEURS SONT DÉCHARGÉS. DANS LE CAS D'UNITÉS À VITESSE VARIABLE, SE REPORTER AUX INSTRUCTIONS DE L'ÉQUIPEMENT POUR DÉCHARGER LES CONDENSATEURS.

CAUTION

USE COPPER CONDUCTORS ONLY! UNIT TERMINALS ARE NOT DESIGNED TO ACCEPT OTHER TYPES OF CONDUCTORS. FAILURE TO DO SO MAY CAUSE DAMAGE TO THE EQUIPMENT.

ATTENTION

LES BORNES DE L'UNITÉ NE SONT PAS CONÇUES POUR RECEVOIR D'AUTRES TYPES DE CONDUCTEURS. L'UTILISATION DE TOUT AUTRE CONDUCTEUR PEUT ENDOMMAGER L'ÉQUIPEMENT.

PRECAUCIÓN

UTILICE ÚNICAMENTE CONDUCTORES DE COBRE! LAS TERMINALES DE LA UNIDAD NO ESTÁN DISEÑADAS PARA ACEPTAR OTROS TIPOS DE CONDUCTORES. SI NO LO HACE, PUEDE OCASIONAR DAÑO AL EQUIPO.

ADVERTENCIA
VOLTAJE PELIGROSO!

DESCONECTE TODA LA ENERGÍA ELÉCTRICA, INCLUIDO LAS DISCONNECTS REMOTOS Y SIGA LOS PROCEDIMIENTOS DE CERRAJE Y ETIQUETADO ANTES DE PROCEDER AL SERVICIO. ASEGURESE DE QUE TODOS LOS CONDENSADORES DE LOS MOTORES SEAN DESCARGADOS. EN EL CASO DE UNIDADES CON CEE DE VELOCIDAD VARIABLE, CONSULTE LAS INSTRUCCIONES PARA LA DESCARGA DEL CONDENSADOR.

EL NO REALIZAR LO ANTERIORMENTE INDICADO, PUEDE OCASIONAR LA MUERTE O SERIAS LESIONES PERSONALES.

Figure 153. Typical schematic for multi-VFD wiring (continued)

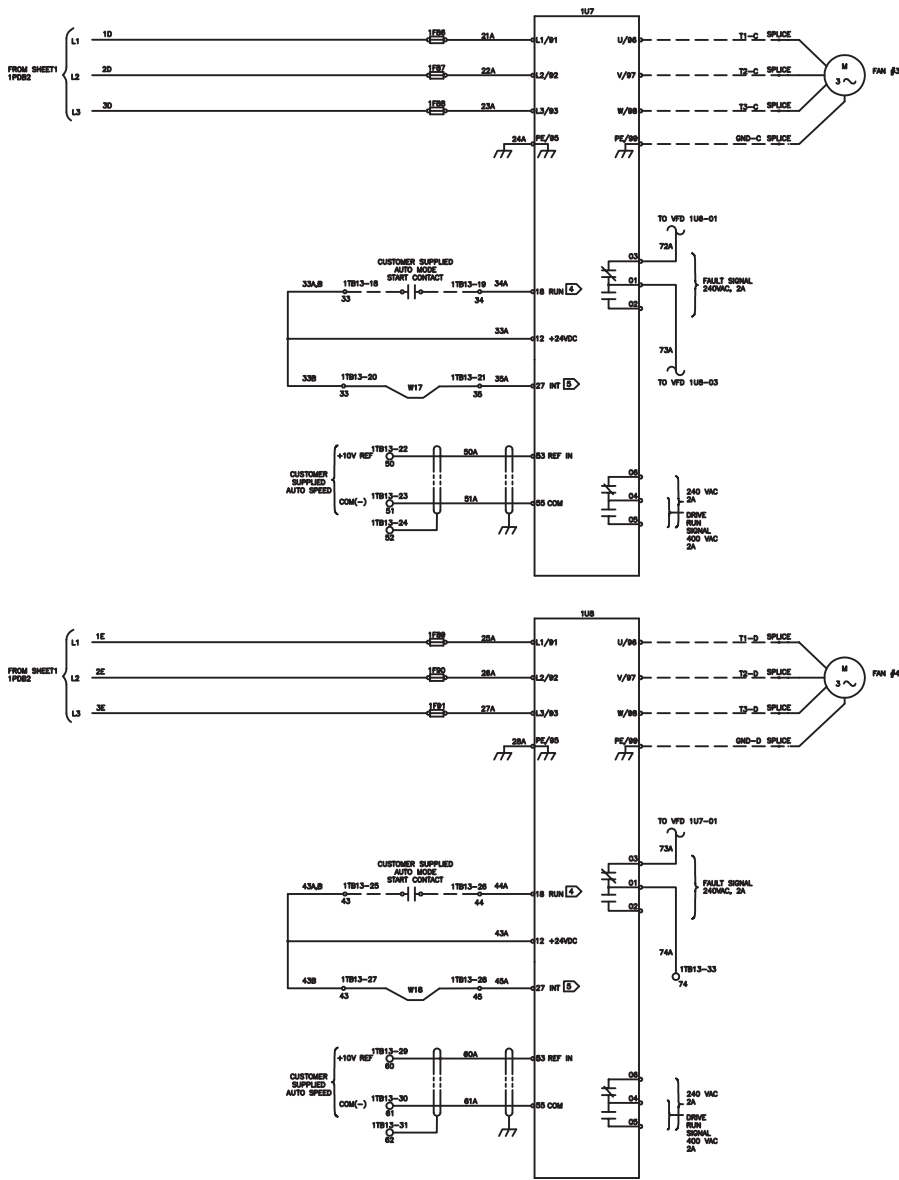

FUSE	VOLTAGE	VFD TRIP	P/N	CLASS	
200	200		11	0020010	CC
			12	0020010	CC
			13	0020010	CC
			14	0020010	CC
230	230		11	0023010	CC
			12	0023010	CC
			13	0023010	CC
			14	0023010	CC
460	460		11	0046010	CC
			12	0046010	CC
			13	0046010	CC
			14	0046010	CC
575	575		11	0057510	CC
			12	0057510	CC
			13	0057510	CC
			14	0057510	CC

INDEX PREFIX LOCATION CODE	LOCATION
1	HIGH VOLTAGE PANEL
2	LOW VOLTAGE PANEL (ONLY SCHEMATIC)
3	LOW VOLTAGE SECTION

- NOTES:
- DASHED LINES INDICATE RECOMMENDED FIELD WIRING BY OTHERS. PHANTOM LINES INDICATE CONTROL, OPTION, REF. CONTROL PANEL SCHEMATIC FOR SPECIFIC DETAIL.
 - ALL FIELD WIRING MUST BE IN ACCORDANCE WITH THE NATIONAL ELECTRICAL CODE, STATE AND LOCAL REQUIREMENTS. OTHER COUNTRIES APPLICABLE NATIONAL AND/OR LOCAL REQUIREMENTS SHALL APPLY. FIELD CONDUCTORS SHALL HAVE INSULATION RATING NOT LESS THAN 600V COPPER CONDUCTORS ONLY.
 - MINIMUM CIRCUIT AMPACITY, MAXIMUM FUSE SIZE, AND DISCONNECT SIZE ARE CALCULATED BASED ON THE INPUT WIRE LINE CURRENTS PER ARTICLE 430-2 OF THE NATIONAL ELECTRICAL CODE.
 - PROGRAM TERMINAL 18 AS RUN.
 - PROGRAM TERMINAL 27 INV. COASTING STOP.
 - CLOSES TO RUN AUTO MODE OR BYPASS AUTO FOR OPTION VFD OR STARTER.
 - RELAYS—CONTACTS: SILVER-CADMIUM OXIDE, 1/8 HP SNAP @ 120V AC, 1/2 HP SNAP @240V AC. SEE 24V SCHEMATIC DIAGRAM FOR COIL CONNECTIONS AND ACTUAL QUANTITY OF TRANSFORMER RELAYS.
 - CUSTOMER SUPPLIED DEVICE, SUCH AS FUSE, BREAKER.
 - OPTIONAL TRIP POWER DISTRIBUTION BLOCK.
 - ATTACH GROUND OR EQUIPMENT GROUND.
 - AWLON SWITCH INPUT, REFER TO LOW VOLTAGE SCHEMATIC.

DEVICE DESIGNATION	LEAD	DESCRIPTION
10B11		CIRCUIT BREAKER
1F80 TO 1F81		VFD FUSES
1F82		POWER DISTRIBUTION BLOCK
1TB13		TERMINAL STRIP CONTROL CIRCUIT
1R1		VFD CONTROLLER 1
1R2		VFD CONTROLLER 2
1R3		VFD CONTROLLER 3
1R4		VFD CONTROLLER 4
1K3		START / STOP RELAY
1R5		LOW LIMIT RELAY

CAUTION
USE COPPER CONDUCTORS ONLY!
UNIT TERMINALS ARE NOT DESIGNED TO ACCEPT OTHER TYPES OF CONDUCTORS.
FAILURE TO DO SO MAY CAUSE DAMAGE TO THE EQUIPMENT.

ATTENTION
N'UTILISER QUE DES CONDUCTEURS EN CUIVRE!
LES BORDES DE L'UNITÉ NE SONT PAS CONÇUES POUR RECEVOIR D'AUTRES TYPES DE CONDUCTEURS.
L'UTILISATION DE TOUT AUTRE CONDUCTEUR PEUT ENDOMMAGER L'ÉQUIPEMENT.

PRECAUCIÓN
UTILICE ÚNICAMENTE CONDUCTORES DE COBRE!
LAS TERMINALES DE LA UNIDAD NO ESTÁN DISEÑADAS PARA ACEPTAR OTROS TIPOS DE CONDUCTORES.
SI NO LO HACE, PUEDE OCASIONAR DAÑO AL EQUIPO.

WARNING
HAZARDOUS VOLTAGE!
DISCONNECT ALL ELECTRIC POWER INCLUDING REMOTE DISCONNECTS AND FOLLOW LOCK OUT AND TAG PROCEDURES BEFORE SERVICING. INSURE THAT ALL MOTOR CAPACITORS HAVE DISCHARGED STORED VOLTAGE. UNITS WITH VARIABLE SPEED DRIVE REFER TO DRIVE INSTRUCTIONS FOR CAPACITOR DISCHARGE. FAILURE TO DO THE ABOVE BEFORE SERVICING COULD RESULT IN DEATH OR SERIOUS INJURY.

AVERTISSEMENT
TENSION DANGEREUSE!
COUPER TOUTES LES TENSIONS ET OUVRIER LES SECTIONNEURS À DISTANCE, PUIS SUIVRE LES PROCÉDURES DE VERROUILLAGE ET DES ÉTIQUETTES AVANT TOUTE INTERVENTION. VÉRIFIER QUE TOUTS LES CONDENSATEURS DES MOTEURS SONT DÉCHARGÉS. DANS LE CAS D'UNITÉS COMPORTANT DES ENTRAINEMENTS À VITESSE VARIABLE SE REPORTER AUX INSTRUCTIONS DE L'ENTRAÎNEMENT POUR DÉCHARGER LES CONDENSATEURS.
NE PAS RESPECTER CES MESURES DE PRÉCAUTION PEUT ENTRAINER DES BLESSURES GRAVES POUSANT ÊTRE MORTELLES.

ADVERTENCIA
VOLTAJE PELIGROSO!
DESCONECTE TODA LA ENERGÍA ELÉCTRICA, INCLUIDO LAS DESCONECCIONES REMOTAS Y SIGA LOS PROCEDIMIENTOS DE CERRAR Y ETIQUETADO ANTES DE PROCEDER AL SERVICIO. ASEGURESE DE QUE TODOS LOS CAPACITORES DEL MOTOR HAYAN DESCARGADO EL ALMACENAMIENTO DE ENERGÍA. PARA LAS UNIDADES CON EJE DE VELOCIDAD VARIABLE, CONSULTE LAS INSTRUCCIONES PARA LA DESCARGA DE LOS CONDENSADORES.
EL NO REALIZAR LO ANTERIORMENTE DICHA, PODRÁ OCASIONAR LA MUERTE O SERVICIOS LESIONES PERSONALES.

Figure 154. Typical schematic for starter wiring

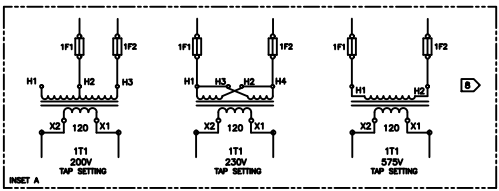
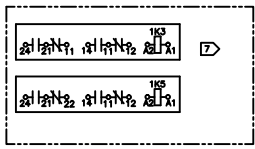
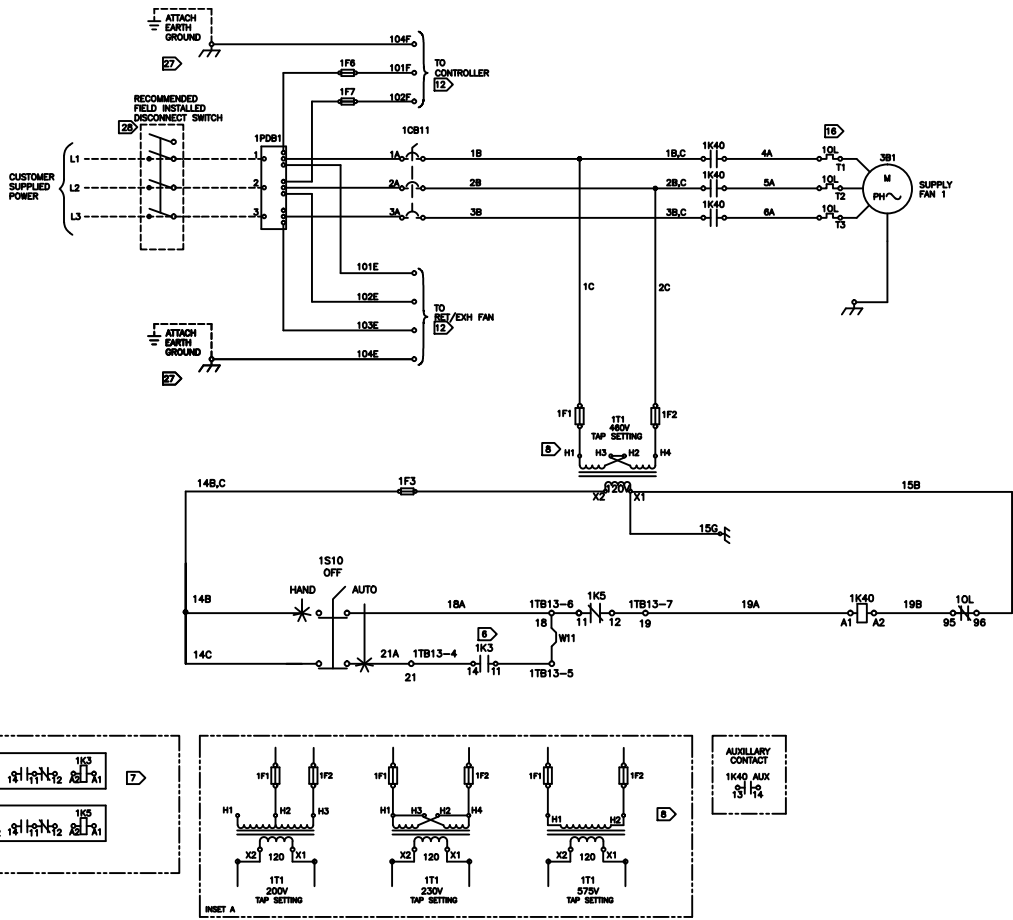

CONTROLLER FUSE (CLASS CC)		
FUSE	VOLTAGE	P/N
1F8	200/230	
1F7	480/575	KLDR-15

PRIMARY CONTROL TRANSFORMER FUSES (CLASS LP-CC)		
FUSE	VOLTAGE	P/N
1F1	200	KLDR-1
	230	KLDR-8/10
1F2	480	KLDR-4/10
	575	KLDR-3/10

SECONDARY CONTROL TRANSFORMER FUSE (CLASS LP-CC)		
FUSE	VOLTAGE	P/N
1F3	120	FLG-8/10

DEVICE PREFIX LOCATION CODE	
AREA	LOCATION
1	HIGH VOLTAGE PANEL
2	LOW VOLTAGE PANEL (UNIT SCHEMATIC)
3	AIR HANDLER SECTION

LEGEND	
DEVICE DESIGNATION	DESCRIPTION
1CB11	CIRCUIT BREAKER
1F1 TO 1F2	PRIMARY CONTROL TRANSFORMER FUSES
1F3	SECONDARY CONTROL TRANSFORMER FUSE
1F8 / 1F7	PRIMARY CONTROLLER FUSE
1K3	START/STOP RELAY
1K5	LOW LIMIT RELAY
1K40	STARTER CONTACTOR
1OL	OVERLOAD RELAY
1PDB1	POWER DISTRIBUTION BLOCK
1S10	HAND/OFF/AUTO SWITCH
1T1	PRIMARY CONTROL TRANSFORMER
1TB13	TERMINAL STRIP CONTROL CIRCUIT
3B1	MOTOR 1

- NOTES:
- DASHED LINES INDICATE RECOMMENDED FIELD WIRING BY OTHERS. PHANTOM LINES INDICATE CONTROL OPTION. REF. CONTROL PANEL SCHEMATIC FOR SPECIFIC DETAIL.
 - ALL FIELD WIRING MUST BE IN ACCORDANCE WITH THE NATIONAL ELECTRICAL CODE (NEC), STATE AND LOCAL REQUIREMENTS. OTHER COUNTRIES APPLICABLE NATIONAL AND/OR LOCAL REQUIREMENTS SHALL APPLY. FIELD CONDUCTORS SHALL HAVE INSULATION RATING NOT LESS THAN 600V COPPER CONDUCTORS ONLY.
 - THE MINIMUM CIRCUIT AMPACITY, THE MAXIMUM FUSE SIZE, AND DISCONNECT SIZE ARE CALCULATED BASED ON THE INVERTER INPUT LINE CURRENTS PER ARTICLE 430-2 OF THE NATIONAL ELECTRICAL CODE.
 - 6 CLOSERS TO RUN AUTO MODE OR BYPASS AUTO FOR OPTION VFD OR STARTER.
 - 7 RELAY(S)—INDUCTIVE LOAD: 1/8 HP @ 240VAC. RESISTIVE LOAD: 5A @ 240VAC. SEE SCHEMATIC DIAGRAM FOR COIL CONNECTIONS AND ACTUAL QUANTITY OF TRANSFORMER RELAYS.
 - 8 CONTROL TRANSFORMER SHOWN FOR 480V PRIMARY. FOR 200V OR 230V OR 575V REFER TO INSET A.
 - 12 IF UNIT HAS SHIPPING SPLITS WIRING WILL TERMINATE TO MODULE AT EACH SHIPPING SPLIT.
 - 16 THE OVERLOAD RELAY TRIP SETTING MUST BE ADJUSTED TO CORRESPOND WITH THE MOTOR FULL LOAD CURRENT AS SHOWN ON THE MOTOR NAMEPLATE.
 - 27 ATTACH GROUND OR EQUIPMENT GROUND.
 - 28 CUSTOMER SUPPLIED LOCKABLE DISCONNECTING MEANS, SUCH AS A DISCONNECT SWITCH OR CIRCUIT BREAKER, INSTALLED LOCAL TO UNIT. SIZE AND PLACEMENT OF DEVICE SHALL BE DONE IN ACCORDANCE WITH APPLICABLE NATIONAL AND LOCAL ELECTRICAL CODES.

Figure 155. Typical schematic for motorized impeller control panel (MICP)

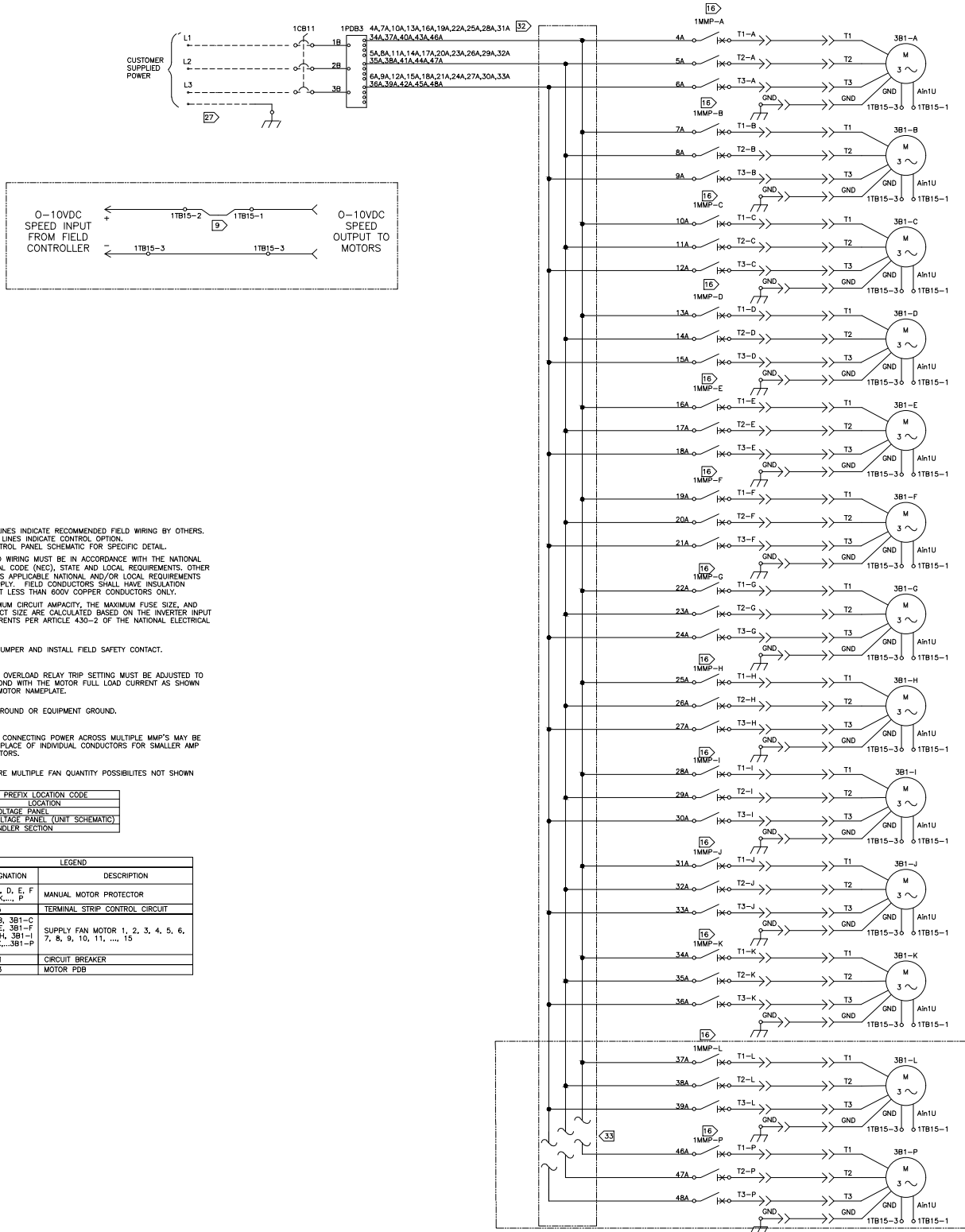

NOTES:

- 1 DASHED LINES INDICATE RECOMMENDED FIELD WIRING BY OTHERS. PHANTOM LINES INDICATE CONTROL OPTION. REF. CONTROL PANEL SCHEMATIC FOR SPECIFIC DETAIL.
 - 2 ALL FIELD WIRING MUST BE IN ACCORDANCE WITH THE NATIONAL ELECTRICAL CODE (NEC), STATE AND LOCAL REQUIREMENTS. OTHER COUNTRIES APPLICABLE NATIONAL AND/OR LOCAL REQUIREMENTS SHALL APPLY. FIELD CONDUCTORS SHALL HAVE INSULATION RATING NOT LESS THAN 600V COPPER CONDUCTORS ONLY.
 - 3 THE MINIMUM CIRCUIT AMPACITY, THE MAXIMUM FUSE SIZE, AND DISCONNECT SIZE ARE CALCULATED BASED ON THE INVERTER INPUT LINE CURRENTS PER ARTICLE 430-2 OF THE NATIONAL ELECTRICAL CODE.
- 9 REMOVE JUMPER AND INSTALL FIELD SAFETY CONTACT.
- 16 MMP AND OVERLOAD RELAY TRIP SETTING MUST BE ADJUSTED TO CORRESPOND WITH THE MOTOR FULL LOAD CURRENT AS SHOWN ON THE MOTOR NAMEPLATE.
- 27 ATTACH GROUND OR EQUIPMENT GROUND.
- 32 BUSBARS CONNECTING POWER ACROSS MULTIPLE MMP'S MAY BE USED IN PLACE OF INDIVIDUAL CONDUCTORS FOR SMALLER AMP DRAW MOTORS.
- 33 THERE ARE MULTIPLE FAN QUANTITY POSSIBILITIES NOT SHOWN

AREA	LOCATION
1	HIGH VOLTAGE PANEL
2	LOW VOLTAGE PANEL (UNIT SCHEMATIC)
3	AIR HANDLER SECTION

DEVICE DESIGNATION	DESCRIPTION
1MMP-A, B, C, D, E, F, G, H, J, K, ..., P	MANUAL MOTOR PROTECTOR
1TB15	TERMINAL STRIP CONTROL CIRCUIT
3B1-A, 3B1-B, 3B1-C, 3B1-D, 3B1-E, 3B1-F, 3B1-G, 3B1-H, 3B1-I, 3B1-J, 3B1-K, ..., 3B1-P	SUPPLY FAN MOTOR 1, 2, 3, 4, 5, 6, 7, 8, 9, 10, 11, ..., 15
1CB11	CIRCUIT BREAKER
1PDB3	MOTOR FDB



Installation - Electrical

Figure 156. Typical schematic for motorized impeller control panel (MICB) with hand off auto and potentiometer

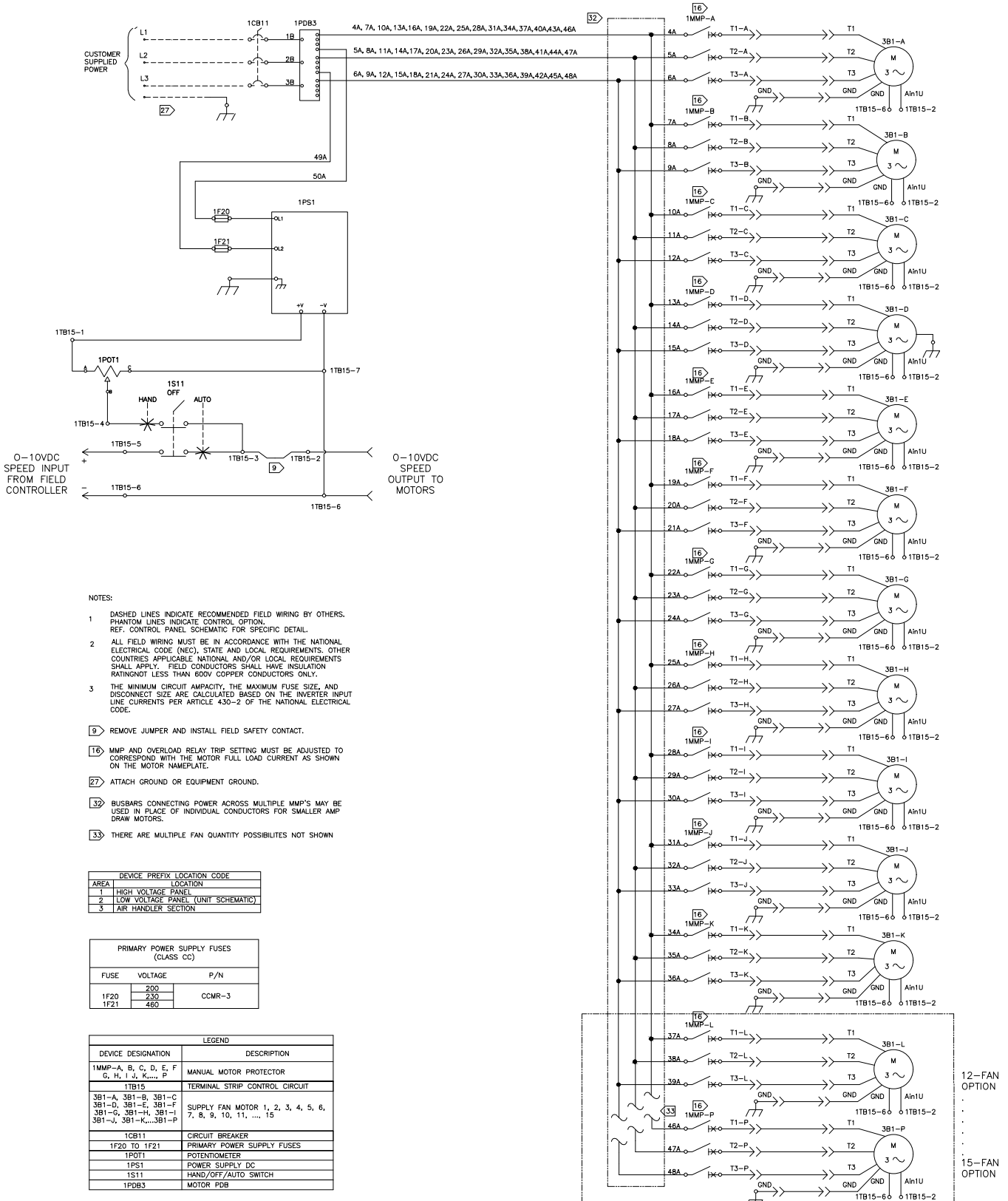
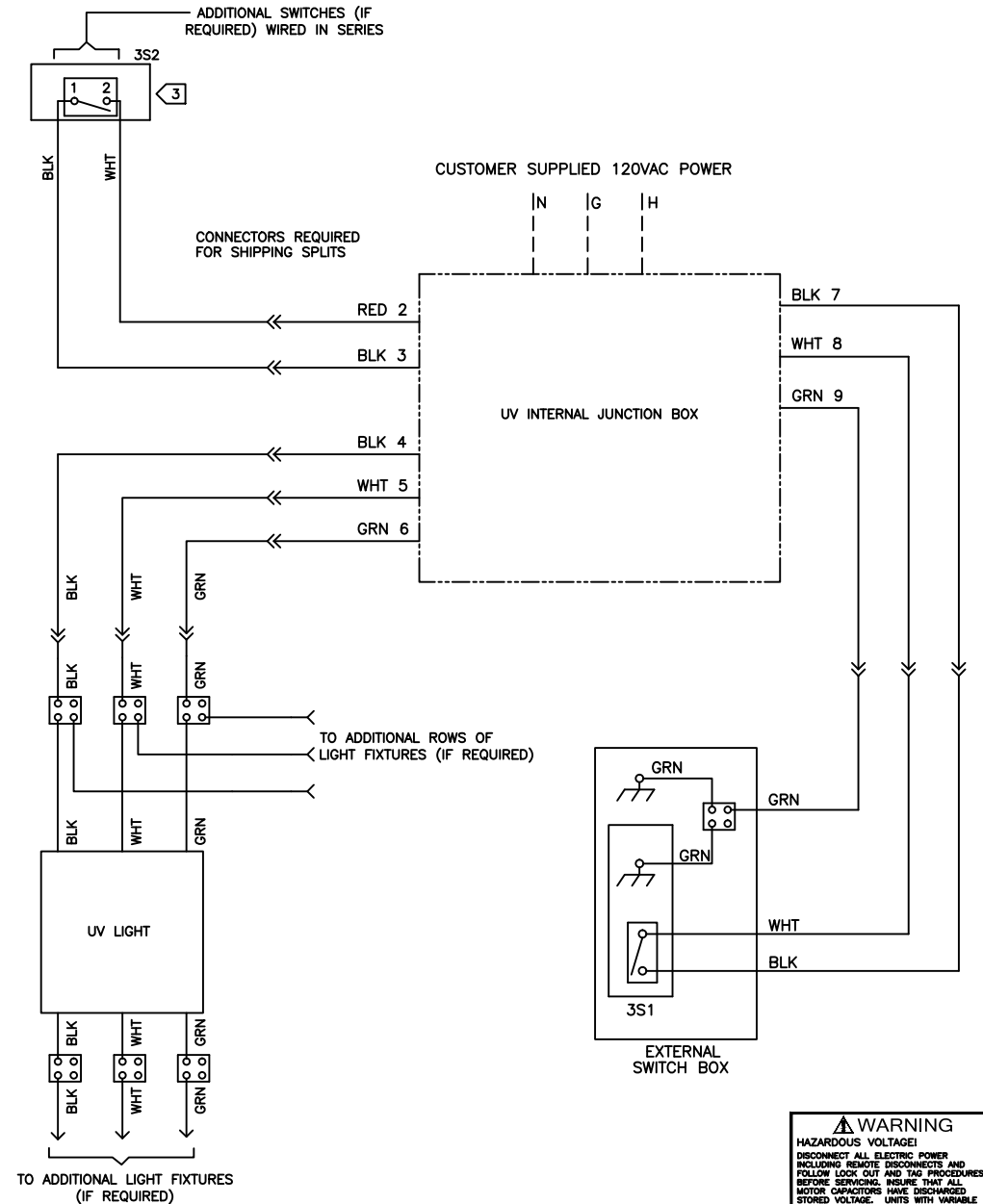

Figure 157. UV lights schematic



LEGEND	
DEVICE DESIGNATION	DESCRIPTION
3S1	MAIN EXTERNAL UV LIGHT SWITCH
3S2	DOOR KILL SWITCH FOR UV LIGHTS

- NOTES:
- DASHED LINES INDICATE RECOMMENDED FIELD WIRING BY OTHERS.
 - ALL FIELD WIRING MUST BE IN ACCORDANCE WITH THE NATIONAL ELECTRICAL CODE (NEC), STATE AND LOCAL REQUIREMENTS. OTHER COUNTRIES' APPLICABLE NATIONAL AND/OR LOCAL REQUIREMENTS SHALL APPLY. FIELD CONDUCTORS SHALL HAVE INSULATION RATING NOT LESS THAN 900V.
 - SWITCH CLOSES WHEN ACCESS DOORS ARE SHUT.
 - UV LAMPS WILL NEED TO BE INSTALLED IN LAMP FIXTURES BEFORE UNIT START UP.
 - UV LAMPS WILL NOT REMOVE AIRBORNE CONTAMINANTS. LAMPS ARE DESIGNED TO CONTROL MICROBIAL GROWTH ON COIL AND DRAIN PAN SURFACES. DO NOT CYCLE LAMPS OFF AND ON. REPLACE LAMPS ONCE PER YEAR.

WARNING
HAZARDOUS VOLTAGE!
DISCONNECT ALL ELECTRIC POWER INCLUDING REMOTE DISCONNECTS AND FOLLOW LOCK OUT AND TAG PROCEDURES BEFORE SERVICING. INSURE THAT ALL MOTOR CAPACITORS HAVE DISCHARGED STORED VOLTAGE. UNITS WITH VARIABLE SPEED DRIVE REFER TO DRIVE INSTRUCTIONS FOR CAPACITOR DISCHARGE. FAILURE TO DO THE ABOVE BEFORE SERVICING COULD RESULT IN DEATH OR SERIOUS INJURY.

AVERTISSEMENT
TENSION DANGEREUSE!
COUPER TOUTES LES TENSIONS ET OUVRIER LES SECTIONNEURS A DISTANCE, PUIS SUIVRE LES PROCEDURES DE VERROUILLAGE ET DES ETIQUETTES AVANT TOUTE INTERVENTION. VERIFIER QUE TOUTS LES CONDENSATEURS DES MOTEURS SONT DECHARGES. DANS LE CAS D'UNITES COMPORTANT DES ENTRAINEMENTS A VITESSE VARIABLE, SE REPORTER AUX INSTRUCTIONS DE L'ENTRAINEMENT POUR DECHARGER LES CONDENSATEURS.

CAUTION
USE COPPER CONDUCTORS ONLY!
UNIT TERMINALS ARE NOT DESIGNED TO ACCEPT OTHER TYPES OF CONDUCTORS.
FAILURE TO DO SO MAY CAUSE DAMAGE TO THE EQUIPMENT.

ATTENTION
N'UTILISER QUE DES CONDUCTEURS EN CUIVRE!
LES BORNES DE L'UNITE NE SONT PAS CONÇUES POUR RECEVOIR D'AUTRES TYPES DE CONDUCTEURS.
L'UTILISATION DE TOUT AUTRE CONDUCTEUR PEUT ENDOMMAGER L'EQUIPEMENT.

PRECAUCIÓN
UTILICE ÚNICAMENTE CONDUCTORES DE COBRE!
LAS TERMINALES DE LA UNIDAD NO ESTÁN DISEÑADAS PARA ACEPTAR OTROS TIPOS DE CONDUCTORES.
SI NO LO HACE, PUEDE OCASIONAR DAÑO AL EQUIPO.

ADVERTENCIA
VOLTAJE PELIGROSO!
DESCONECTE TODA LA ENERGIA ELECTRICA, INCLUIDO LAS DISCONEXIONES REMOTAS Y SIGA LOS PROCEDIMIENTOS DE CIERRE Y ETIQUETADO ANTES DE PROCEDER AL SERVICIO. ASEGURESE DE QUE TODOS LOS CAPACITORES DEL MOTOR HAYAN DESCARGADO EL VOLTAJE ALMACENADO. PARA LAS UNIDADES CON EJE DE VELOCIDAD VARIABLE, CONSULTE LAS INSTRUCCIONES PARA LA DESCARGA DEL CONDENSADOR.

EL NO REALIZAR LO ANTERIORMENTE INDICADO, PODRÍA OCASIONAR LA MUERTE O SERIAS LESIONES PERSONALES.

Figure 158. Typical schematic for customer-supplied power for GFCI and lights/switch

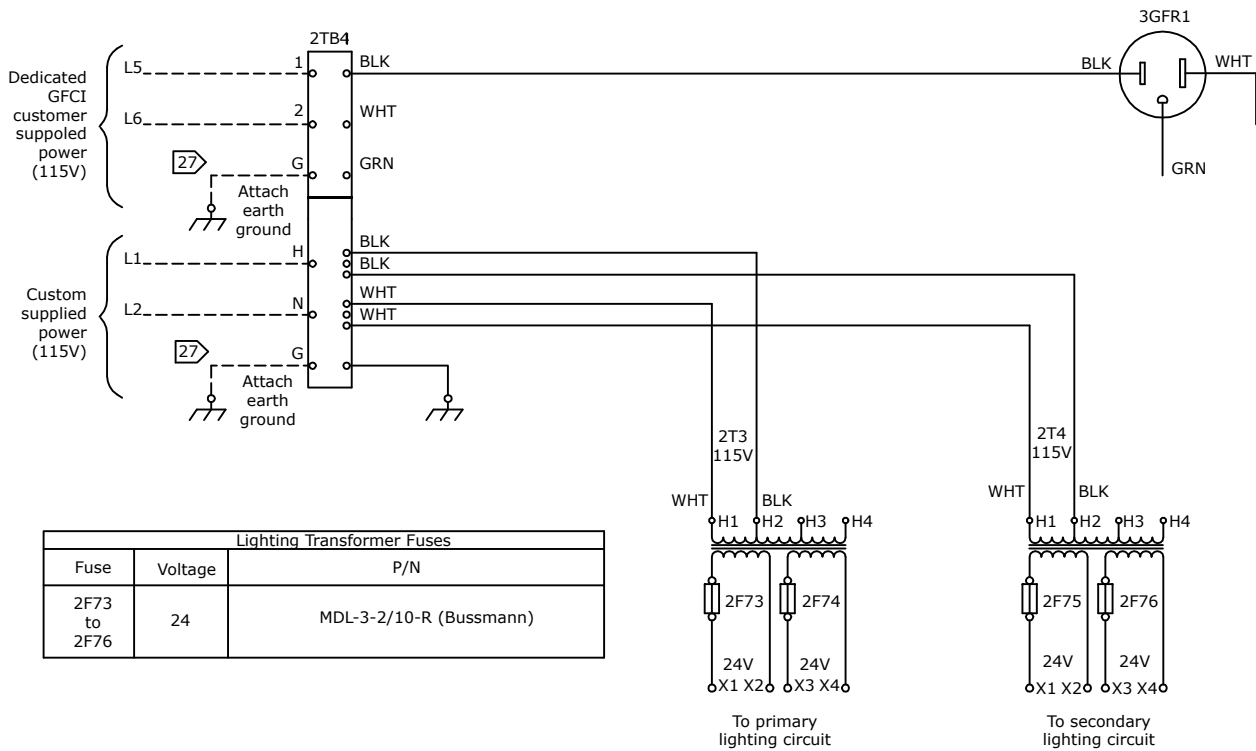

Lighting Transformer Fuses		
Fuse	Voltage	P/N
2F73 to 2F76	24	MDL-3-2/10-R (Bussmann)

Legend	
Device Designation	Description
2TP4	Terminal block GFCI/lighting circuits
2T3	Primary lighting transformer
2T4	Secondary lighting transformer
3GFR1	Ground fault receptacle

Device Prefix Location Code	
Area	Location
1	High voltage panel
2	Low voltage panel (unit schematic)
3	Air handler section

- Notes:
- Dashed lines indicate recommended field wiring by others. Phantom lines indicate control options. Ref. Control panel schematic for specific detail.
 - All field wiring must be in accordance with the National Electrical Code (NEC), state and local requirements. Other countries applicable national and/or local requirements shall apply. Field conductors shall have insulation rating not less than 600V copper conductors only.
 - The minimum circuit ampacity, the maximum fuse size, and disconnect size are calculated based on the inverter input line currents per Article 430-2 of the National Electrical Code.
- Ⓜ Attach ground or equipment ground.

Figure 159. Typical schematic for TCAPS

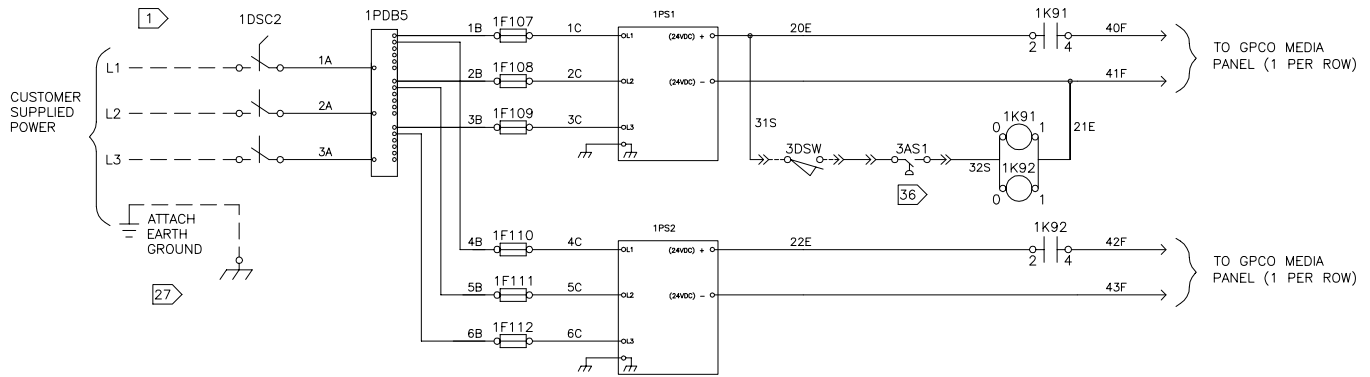

NOTES:

- 1 DASHED LINES INDICATE RECOMMENDED FIELD WIRING BY OTHERS. PHANTOM LINES INDICATE CONTROL OPTION. REF. CONTROL PANEL SCHEMATIC FOR SPECIFIC DETAIL.
- 2 ALL FIELD WIRING MUST BE IN ACCORDANCE WITH THE NATIONAL ELECTRICAL CODE, STATE, AND LOCAL REQUIREMENTS. OTHER COUNTRIES APPLICABLE NATIONAL AND/OR LOCAL REQUIREMENTS SHALL APPLY. FIELD CONDUCTORS SHALL HAVE INSULATION RATING NOT LESS THAN 600V COPPER CONDUCTORS ONLY.
- 3 MINIMUM CIRCUIT AMPACITY, MAXIMUM FUSE SIZE, AND DISCONNECT SIZE ARE CALCULATED BASED ON THE INVERTER INPUT LINE CURRENTS PER ARTICLE 430-2 OF THE NATIONAL ELECTRICAL CODE.
- 27 ATTACH GROUND OR EQUIPMENT GROUND.
- 36 AIR PROVING SWITCH FOR CIRCUIT CUTOFF.

POWER SUPPLY FUSES				
FUSE	VOLTAGE	POWER SUPPLY(W)	P/N	CLASS
1F107 1F108 1F109	115-230	120	LP-CC-6	CC
		240	LP-CC-10	CC
		480	LP-CC-10	CC
1F110 1F111 1F112	460-575	120	LP-CC-6	CC
		240	LP-CC-6	CC
		480	LP-CC-6	CC
		960	LP-CC-8	CC

AREA	DEVICE PREFIX	LOCATION CODE
1	HIGH VOLTAGE PANEL	
2	LOW VOLTAGE PANEL (UNIT SCHEMATIC)	
3	AIR HANDLER SECTION	

LEGEND	
DEVICE DESIGNATION	DESCRIPTION
1DSC2	PANEL DISCONNECT
1F107 TO 1F112	POWER SUPPLY FUSES
1K91-1K92	CUTOFF RELAY
1PDB5	POWER DISTRIBUTION BLOCK
1PS1	DC POWER SUPPLY
3AS1	AIR PROVING SWITCH
3DSW	DOOR SWITCH



Controls Interface

Leak Detection Programming

Unit shall be furnished with a leak detection system from the factory. The leak detection system shall consist of one or more refrigerant detection sensors. When the system detects a leak, the unit controller shall initiate mitigation actions. See “A2L Application Considerations,” p. 24.

Factory-installed Symbio™ 500 controllers are programmed with leak detection sequence of operations at the factory.

Field-installed unit controllers require field programming of the leak detection sequence of operations by the controls contractor.

Factory-installed digital terminal blocks, which use an unprogrammed Symbio™ 500 controller, require field programming of the leak detection sequence of operations by the controls contractor.

See UL 60335–2–40 for more information.

Operator Display

The portable operator display is used for temporary connection to and operation of Trane Symbio™ controller. With the portable operator display, you can monitor data, change setpoints, monitor alarms, and override points. The portable operator display includes a 10 ft (3 m) cable with connector that is stored in the storage compartment of the carrying bag. The cable cannot be disconnected from the operator display. Keep this document with the portable operator display for access to calibration and cleaning instructions.

Note: The portable operator display is not used for timeclock scheduling. To provide scheduling you must use a Tracer Summit system

NOTICE

Display Damage!

Failure to follow instructions below could result in damage to the display.

Do not install in direct sunlight.

Connecting the Operator Display

To connect the portable operator display:

1. Locate the factory-provided service module (see Figure 160, p. 132).
2. Attach the operator-display cable to the operator-display connector on the service module. The operator display receives power from the controller and turns on automatically when it is connected.

Figure 160. Service module



NOTICE

Display Damage!

Failure to follow instructions below could result in damage to the display.

Use a cloth dampened with commercial liquid glass cleaner to clean the operator display. Do not spray water or cleaner directly on screen.

Calibrating the Operator Display

This section shows how to calibrate the operator display touch screen and how to adjust the brightness and contrast. To set up the operator display screens and security, see *Tracer TD-7 Display for the Tracer UC600 Programmable Controller Installation, Operation, and Maintenance* (BAS-SVX50*- EN).

To calibrate the operator display:

1. On the home screen, press Setup. The Setup menu appears.
2. Page down to view the next screen.
3. Press Calibrate Touch Screen. A calibration screen appears.

NOTICE

Equipment Damage!

Failure to follow instructions below could result in equipment damage.

Protect operator display from contact with sharp objects.

4. Touch the target using a small, pliable, blunt object, such as a pencil eraser or your finger. Hold until the beeping stops. A second calibration screen appears.
5. Again, touch the target with the object. Hold until the beeping stops. The Advanced Selection screen appears.
6. Press Home. The home screen appears.

Adjusting Brightness and Contrast

To adjust the brightness and contrast of the operator display:

1. On the home screen, press Setup. The Setup menu appears.
2. Page down to view the next screen.
3. Press the Adjust Brightness and Contrast buttons. The Brightness and Contrast screen appears.
4. To increase the brightness, press the buttons along the top row, in sequence, from left to right. To decrease the brightness, press the buttons from right to left.

Note: *Contrast adjustment is not available on all computer display models.*

5. To increase the contrast, press the buttons along the bottom row, in sequence, from left to right. To decrease the contrast, press the buttons from right to left.
6. Press Home. The home screen appears.

External Communications Port

Units with a factory-provided DDC controller can include a service module with an external communications port when purchased. Both the operator display and Tracer® TU service tool can be connected without shutting off the unit through the external communications port. Open the cover plate on the service module and plug into the RJ-45 port for the operator display or the USB port for the Tracer TU service tool. This enables continuous operation of the air handler without disruption to the operating conditions of the unit. When servicing of the unit is complete, close the cover plate on the service module to eliminate any air leakage path.



Start-Up

Pre-Start-up Checklist

Complete this checklist after installing the unit to verify all recommended installation procedures are complete before unit start-up. This does not replace the detailed instructions in the appropriate sections of this manual. Disconnect electrical power before performing this checklist. Always read the entire section carefully to become familiar with the procedures.

⚠ WARNING

Hazardous Voltage w/Capacitors!

Failure to disconnect power and discharge capacitors before servicing could result in death or serious injury.

Disconnect all electric power, including remote disconnects and discharge all motor start/run capacitors before servicing. Follow proper lockout/tagout procedures to ensure the power cannot be inadvertently energized. For variable frequency drives or other energy storing components provided by Trane or others, refer to the appropriate manufacturer's literature for allowable waiting periods for discharge of capacitors. Verify with a CAT III or IV voltmeter rated per NFPA 70E that all capacitors have discharged.

General Checks

- Ensure the unit has been installed level.
- Ensure supply-air and return-air ducts have been connected.
- Ensure damper operator motors and connecting linkage have been installed.
- Verify damper operation and linkage alignment.
- Check that air filters are in place and positioned properly.
- Remove any debris from the unit interior.
- Remove all foreign material from the drain pan and check drain pan opening and condensate line for obstructions.
- Close and secure all unit access doors.
- If differential pressure switch is provided on filter rack, adjust per system requirements.
- Inspect electrical connections to the unit
 - Connections should be clean and secure.
 - Compare the actual wiring with the unit diagrams.
- Check piping and valves for leaks. Open or close the valves to check for proper operation. Drain lines should be open.
- Leave this manual with the unit.

Fan-Related Checks

- If the unit is not externally isolated, ensure that the fan isolator tie-down bolts have been removed. See “Fan Isolation,” p. 82.
- Rotate all fan wheels manually to confirm they turn freely in the proper direction.
- Check fan shaft bearings, fan wheel, and drive sheave set screws for proper torque settings.
 - Fan sheaves should be tight and aligned.
- Inspect fan motor and bearings for proper lubrication, if necessary. See “Fan Bearing Lubrication,” p. 161.

Coil-Related Checks

NOTICE

Proper Water Treatment Required!

The use of untreated or improperly treated water could result in scaling, erosion, corrosion, algae or slime.

Use the services of a qualified water treatment specialist to determine what water treatment, if any, is required. Trane assumes no responsibility for equipment failures which result from untreated or improperly treated water, or saline or brackish water.

- Ensure coil and condensate drain piping connections are complete.
- Check the piping and valves for leaks.
 - Open or close the valves to check operation.
 - The drain lines should be open.
- If unit has a refrigerant coil, ensure that it has been charged and leak-tested according to the instructions provided with the condenser equipment. Adjust the superheat setting.
- Remove all foreign material from the drain pan and check the pan opening and condensate line for obstructions.
- For steam coils, slowly turn the steam on full for at least 10 minutes before opening the fresh air intake on units with fresh air dampers.

Motor-Related Checks

- Locate installation manual from the motor manufacturer for the specific motor installed. This can be found by contacting the motor manufacturer's representative. The motor manufacturer's recommendations take precedence for all matters related to the start-up and routine maintenance of the motor.
- For supply fan motor, check the motor lubrication for moisture and rust.
 - Remove and clean grease plugs to inspect.

- If moisture is present, consult an authorized repair shop for bearing inspection/replacement. This may require removal and transport of motor.
- If no moisture is present, refer to the motor manufacturer's lubrication recommendations for proper lubrication.
- The motor manufacturer may recommend lubricating the motor as part of their routine start-up instructions.
- Check motor winding. An acceptable winding resistance reading is from 6 meg-ohms to infinity. If reading is less than 5 mega-ohms, the winding should be dried out in an oven or by a blower.
- Inspect the entire motor for rust and corrosion.
- Bump-start the unit and confirm the fan wheel rotates properly, as indicated by the rotation arrow located on the fan housing.

Note: For motor warranty needs, contact your local Trane sales office.

Unit Operation

⚠ WARNING

Rotating Components!

Failure to disconnect power before servicing could result in rotating components cutting and slashing technician which could result in death or serious injury.

During installation, testing, servicing and troubleshooting of this product it may be necessary to work with live and exposed rotating components. Have a qualified or licensed service individual who has been properly trained in handling exposed rotating components, perform these tasks.

⚠ WARNING

Live Electrical Components!

Failure to follow all electrical safety precautions when exposed to live electrical components could result in death or serious injury.

When it is necessary to work with live electrical components, have a qualified licensed electrician or other individual who has been properly trained in handling live electrical components perform these tasks.

Before complete start-up, bump-start the unit and confirm the fan wheel rotates properly, as indicated by the rotation arrow located on the fan housing.

After initial start-up:

- Calculate the motor voltage imbalance, notifying the power company to correct unacceptable imbalances.
- Periodically check the fan belt tension.

Calculate Motor Voltage Imbalance

After start-up, measure the motor voltage and amperage on all phases to ensure proper operation. The readings should fall within the range given on the motor nameplate. The maximum allowable voltage imbalance is 2 percent.

Voltage imbalance is defined as 100 times the sum of the deviation of the three voltages from the average, divided by twice the average voltage. For example, if the three measured voltages are 221, 230 and 227, the average voltage would be 226 volts. The percent of voltage imbalance is then calculated.

$$\text{Voltage imbalance} = \frac{100 A}{2 \times \text{Avg voltage}}$$

Where:

$$A = (226-221) + (230-226) + (227-226)$$

$$\text{Voltage imbalance} = 2.2\% \text{ (not acceptable)}$$

In the example, 2.2 percent imbalance is not acceptable and the power company should be notified to correct it.

VFD Programming Parameters

Units shipped with an optional variable frequency drive (VFD) are preset and run-tested at the Trane factory. If a problem with a VFD occurs, ensure that the programmed parameters listed in [Table 37, p. 136](#) have been set. If trouble still persist after verifying factory parameters are correct, call Trane Drive Technical Support at 1-877-872-6363. Have the unit serial number from the drive available for the technical support representative. The technician will determine if drive can be repaired or needs to be replaced or needs to be replaced. TR150 start-up check list available on the HUB - DOC-116469.

Table 36. Trane TR150 switching frequency

Horsepower	Voltage Max	KHz	Trane Setting
0.5 – 15	208/230	16	16
20 – 60	208/230	12	12
0.5 – 30	460	16	16
40 – 125	460	12	12
0.5 – 10	575	12	12
15 – 125	575	8	8

⚠ WARNING

Hazardous Voltage w/Capacitors!

Failure to disconnect power and discharge capacitors before servicing could result in death or serious injury.

Disconnect all electric power, including remote disconnects and discharge all motor start/run capacitors before servicing. Follow proper lockout/tagout procedures to ensure the power cannot be inadvertently energized. For variable frequency drives or other energy storing components provided by Trane or others, refer to the appropriate manufacturer's literature for allowable waiting periods for discharge of capacitors. Verify with a CAT III or IV voltmeter rated per NFPA 70E that all capacitors have discharged.

Table 37. Trane TR150 VFD programming parameters

Parameter # TR150	Description	Factory Default	Trane Setting
0-03	Region	International	North American
1-03	Torque Characteristics	Auto Energy Optim. VT	Auto Energy Optim. VT [3] for Belt-Drive Fans Variable Torque [1] for Direct-Drive Fans
1-20	Motor Power	Depends on unit	Set Based on Motor Nameplate
1-22	Motor Voltage	Depends on unit	Set Based on Motor Nameplate
1-24	Motor Current	Depends on unit	Set Based on Motor Nameplate
1-25	Rated Motor	Speed Depends on unit	Set Based on Motor Nameplate
1-71	Start Delay	0.0 Sec	2 Sec
1-73	Flying Start	Disabled	Enable
1-90	Motor Thermal Protection	ETR Trip 1 [4]	ETR Trip 1 [4]
3-02	Minimum Reference	Application dependant	0 Hz
3-03	Maximum Reference	60Hz	60 or the Value of Maximum Inverter Frequency (Hz) on nameplate if fan is direct drive.
3-15	Terminal 53 Analog Input	Analog Input 53	Analog Input 53
3-41	Ramp-up Time	Application dependant	30 Sec
3-42	Ramp-down Time	Application dependant	30 Sec
4-12	Output Freq Low Limit	Application dependant	20 Hz
4-14	Output Freq High Limit	60 or the Value of Maximum Inverter Frequency (Hz) on nameplate if fan is direct drive.	60 or the Value of Maximum Inverter Frequency (Hz) on nameplate if fan is direct drive.
4-18	Current Limit	Application dependant	110%
4-19	Max Output Frequency	Application dependant	65 Hz or 120 Hz for Direct Drive Fan
5-12	Terminal 27 Digital	Input No Operation	Coast Inverse
5-40	Function Relay	No Operation	Relay 1 Active No Alarm [160] Relay 2 Active Motor Running [5]
6-14	Terminal 53 Low Ref Feedback	0.0 Hz	20 Hz

Table 37. Trane TR150 VFD programming parameters (continued)

Parameter # TR150	Description	Factory Default	Trane Setting
6-15	Terminal 53 High Ref Feedback	Application dependant	60 or the Value of Maximum Inverter Frequency (Hz) on Nameplate if fan is direct drive.
14-01	Switching Frequency	5.0 kHz	Set to Max for HP (see Table 36, p. 135)
14-20	Reset Mode	Manual Reset	Automatic Reset x 5

Airflow Measuring Systems

Traq™ Dampers

Traq dampers are low-leak dampers that modulate and measure airflow. Each Traq damper section is supplied with a factory-mounted ventilation control module (VCM) on the interior of the mixing box section. The VCM has an input terminal for power and an output terminal for air velocity (see Figure 161, p. 137). A direct-digital controller controls the factory-mounted and wired actuators.

Figure 161. Traq damper terminal connections

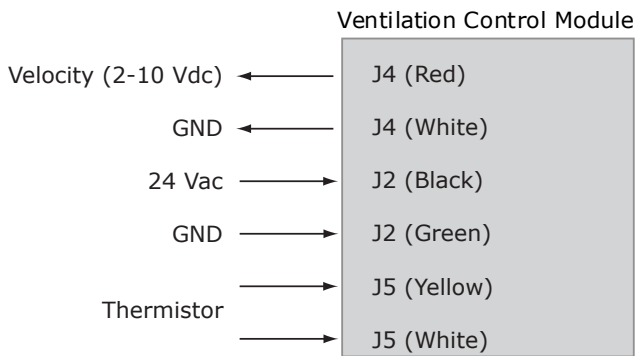
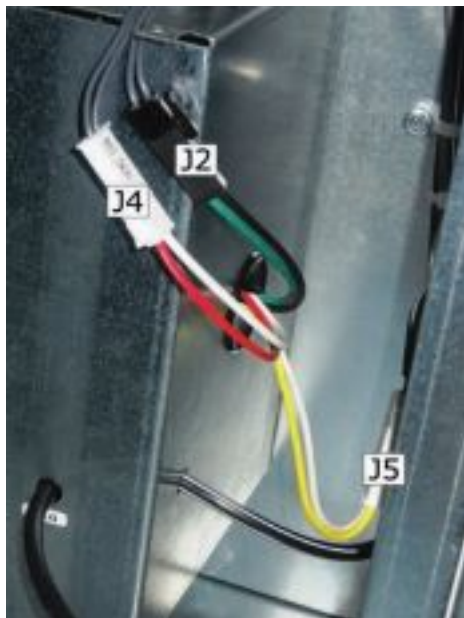

Figure 162. Traq damper terminal connections



VCM (Transducer) Calibration: The VCM has an autozero function that recalibrates the transducer once every minute. When troubleshooting, allow for the recalibration time before making any measurements.

Input Power: The only input the VCM needs is the 24 Vac power connected to the J2 plug (green and black wires).

Output Velocity Signal: The 2 to 10 Vdc linear output signal from the VCM represents air velocity. This voltage can be converted to represent airflow (cfm or L/s) using the formula below and Table 38, p. 137.

$$\text{Airflow} = k (\text{cfm @ 10V}) \left[\frac{(\text{volts } 2)}{8} \right]$$

or

$$\text{Airflow} = k (\text{L/s @ 10V}) \left[\frac{(\text{volts } 2)}{8} \right]$$

For example, if the VCM on a size 30 air handler at sea level ($k = 1$) has a 10-volt signal, it would represent 24,492 cfm (11,559 L/s) through the Traq damper. If the voltage were 6 volts, airflow through the Traq damper would be 12,246 cfm (5779 L/s).

Table 38. Altitude adjustment factors

Sea level = 1.0	
Elevation (feet)	k
1000	0.982
2000	0.964
3000	0.949
4000	0.930
5000	0.914
6000	0.897
7000	0.876
8000	0.860
9000	0.846
10,000	0.825

In Table 39, p. 138 through Table 44, p. 139, the cfm at 10Vdc is a calculated value based on area and peak velocity. In certain situations, it can be advantageous to raise the velocity of air through the remaining Traq dampers by closing off one or more dampers in the unit. The cfm at 10Vdc can be recalculated based on the



Start-Up

proportion of remaining Traq dampers or by multiplying the remaining area of dampers by peak velocity. Calculations

are based on VCM voltage versus airflow at sea level. Setup details are available on the HUB - DOC-106531.

Table 39. Back or top inlet standard Traq damper-air mixing and indoor economizer section

Unit Size	Part Number	Traq Damper Size (inches)	Quantity	Peak Velocity (fpm)	Total Area (ft ²)	CFM @10Vdc Peak Velocity	L/s @ 10Vdc Peak Velocity
3	495100860001	13	1	2475	0.92	2279	1076
4, 6	495100860001	13	2	2475	1.84	4559	2151
8, 10	495100860001	13	3	2475	2.76	6838	3227
12, 14, 17	495100870001	16	3	2475	4.19	10,365	4891
21, 25	495100890001	20	3	2600	6.54	17,012	8028
30, 35, 40	495100880001	24	3	2600	9.42	24,492	11,558
50, 57	495100900001	28	3	2600	12.83	33,358	15,742
66	495100900001	28	4	2600	17.10	44,460	20,981
80	495100900001	28	5	2600	21.38	55,588	26,232
100, 120	495100900001	28	6	2600	25.66	66,716	31,483

Table 40. Back or top inlet low-flow Traq damper-air mixing and indoor economizer sections

Unit Size	Part Number	Traq Damper Size (in)	Damper Type	Qty	Peak Velocity (fpm)	Total Area (ft ²)	CFM @ 10Vdc Peak Velocity	L/s @ 10Vdc Peak Velocity
6	495100860001	13	Min. Outside Air	1	2475	0.92	2279	1076
8, 10	495100860001	13	Min. Outside Air	1	2475	0.92	2279	1076
12, 14, 17	495100870001	16	Min. Outside Air	1	2475	1.40	3455	1630
21, 25	495100890001	20	Min. Outside Air	1	2600	2.18	5671	2676
30, 35, 40	495100880001	24	Min. Outside Air	1	2600	3.14	8164	3853
50, 57	495100900001	28	Min. Outside Air	1	2600	4.27	11,112	5244
66	495100900001	28	Min. Outside Air	1	2600	4.27	11,112	5244
80	495100900001	28	Min. Outside Air	2	2600	8.54	22,224	10,488
100	495100900001	28	Min. Outside Air	2	2600	8.54	22,224	10,488
120	495100900001	28	Min. Outside Air	2	2600	8.54	22,224	10,488

Table 41. Mixing box Traq damper inlet - single-side standard flow

Unit size	Part number	Traq damper size (in)	Qty	Peak velocity (fpm)	Total area (ft ²)	CFM@10Vdc peak velocity	L/s@ 10Vdc peak velocity
3, 4, 6, 8	495100860001	13	1	2475	0.92	2279	1076
10, 12	495100870001	16	1	2475	1.40	3455	1631
14, 17	495100860001	13	2	2475	1.84	4559	2152
21, 25	495100870001	16	2	2475	2.79	6910	3262
30, 35, 40	495100890001	20	2	2600	4.36	11,341	5354
50, 57, 66	495100880001	24	2	2600	6.28	16,328	7708
80	495100900001	28	2	2600	8.59	22,225	10,492

Table 41. Mixing box Traq damper inlet - single-side standard flow (continued)

Unit size	Part number	Traq damper size (in)	Qty	Peak velocity (fpm)	Total area (ft ²)	CFM@10Vdc peak velocity	L/s@ 10Vdc peak velocity
100	495100900001	28	3	2600	12.82	33,337	15,738
120	495100880001	24	4	2600	12.56	32,656	15,417

Table 42. Mixing box Traq damper inlet - single-side low flow

Unit size	Part number	Traq damper size (in)	Damper type	Qty	Peak velocity (fpm)	Total area (ft ²)	CFM@10Vdc peak velocity	L/s@ 10Vdc peak velocity
14, 17	495100860001	13	Min. Outside Air	1	2475	0.92	2279	1076
21, 25	495100870001	16	Min. Outside Air	1	2475	1.40	3455	1631
30, 35, 40	495100890001	20	Min. Outside Air	1	2600	2.18	5671	2677
50, 57, 66	495100880001	24	Min. Outside Air	1	2600	3.14	8164	3854
80	495100900001	28	Min. Outside Air	1	2600	4.27	11,112	5246
100	495100900001	28	Min. Outside Air	1	2600	4.27	11,112	5246
120	495100880001	24	Min. Outside Air	1	2600	3.14	8164	3854

Table 43. Mixing box Traq damper inlet - dual-side standard flow

Unit size	Part number	Traq damper size (in)	Qty	Peak velocity (fpm)	Total area (ft ²)	CFM@10Vdc peak velocity	L/s@ 10Vdc peak velocity
3, 4, 6, 8	495100860001	13	2	2475	1.84	4559	2152
10, 12	495100870001	16	2	2475	2.79	6910	3262
14, 17	495100860001	13	4	2475	3.68	9118	4305
21, 25	495100870001	16	4	2475	5.58	13,820	6525
30, 35, 40	495100890001	20	4	2600	8.72	22,682	10,708
50, 57, 66	495100880001	24	4	2600	12.56	32,656	15,417
80	495100900001	28	4	2600	17.10	44,450	20,985
100	495100900001	28	6	2600	25.64	66,674	31,477
120	495100880001	24	8	2600	25.12	65,312	30,834

Table 44. Mixing box Traq damper inlet - dual-side low-flow

Unit size	Part number	Traq damper size (in)	Damper type	Qty	Peak velocity (fpm)	Total area (ft ²)	CFM@10Vdc peak velocity	L/s@ 10Vdc peak velocity
3, 4, 6, 8	495100860001	13	Min. Outside Air	1	2475	0.92	2279	1076
10, 12	495100870001	16	Min. Outside Air	1	2475	1.40	3455	1631
14, 17	495100860001	13	Min. Outside Air	1	2475	0.92	2279	1076
21, 25	495100870001	16	Min. Outside Air	1	2475	1.40	3455	1631

Table 44. Mixing box Traq damper inlet - dual-side low-flow (continued)

Unit size	Part number	Traq damper size (in)	Damper type	Qty	Peak velocity (fpm)	Total area (ft ²)	CFM@10Vdc peak velocity	L/s@ 10Vdc peak velocity
30, 35, 40	495100890001	20	Min. Outside Air	1	2600	2.18	5671	2677
50, 57, 66	495100880001	24	Min. Outside Air	1	2600	3.14	8164	3854
80	495100900001	28	Min. Outside Air	1	2600	4.27	11,112	5246
100	495100900001	28	Min. Outside Air	1	2600	4.27	11,112	5246
120	495100880001	24	Min. Outside Air	1	2600	3.14	8164	3854

Trane utilizes AMCA certification for airflow measuring stations. Trane certifies that the Traq damper herein is licensed to bear the AMCA seal. The ratings shown are based on tests and procedures performed in accordance with AMCA Publication 611 and comply with the requirements of the AMCA Certified Ratings Program.

The certification program provides the engineer and owner assurance that manufacturer-published performance ratings for airflow measurement stations are accurate and repeatable. Trane Traq dampers are certified with the integral ventilation control module which converts differential pressure to an electronic signal for control.

See *Performance Climate Changer Air Handler Sizes 3 to 120 Indoor and Outdoor Units catalog* (CLCH-PRC015*-EN) for Traq damper testing and rating information.

Fan Inlet Airflow Measuring System

A fan inlet airflow measuring system (piezometer) is available on many centrifugal and plenum fans. Trane system determines airflow using a static pressure differential.

Note: *This type of system is different than a total pressure or thermal dispersion system. As such, the calculations will be different.*

Each system comes with a differential pressure transmitter. The minimum diameter is connected to the LO port of the transmitter and the reference pressure point is connected to (or actually is) the HI port of the transmitter.

Figure 163. Fan inlet airflow measuring system

Figure 164. Typical transmitter install for DDP fans

Wiring

The transmitter requires 24 Vdc/24 Vac power on terminals 1 (+) and 2 (ground) of the transmitter. When the airflow measurement system is ordered with a factory-mounted Symbio™ controller, the 24 Vdc power will be supplied.

In the absence of a factory-mounted Symbio controller, the installing contractor must ensure the transmitter has 24 Vdc/24 Vac power.

Transmitter Sizing

The Trane specification requires that the flow meter option have a total accuracy of 5 percent. The total accuracy is a combination of:

- how accurately the flow meter itself is in sensing airflow
- how accurately the transmitter senses the differential pressure
- how accurately the controller translates the signal from the transmitter to a differential pressure.

Selecting the proper transmitter is critical in order to get accurate airflow measurements. How accurately the transmitter senses the differential pressure is dependent on:

- the pressure range selected
- the accuracy of the selected transmitter

Trane air handlers use a 0 to 5-inch, 0 to 10-inch, or 0 to 25-inch w.g. range transmitter as standard. To sufficiently cover VAV turndown on the smallest fans with the above range, a transmitter with an accuracy of 0.25 percent (full scale) is used as standard. If a field-provided transmitter with a lower accuracy is selected, the range should be chosen closer to the actual, maximum pressure differential expected for the application.

The transmitter outputs a signal that represents the differential pressure which is used to calculate airflow. To adequately calculate and display the airflow for the smaller fans, ensure that the analog input is programmed with enough decimal places to sufficiently represent the pressure differential being measured.

Note: *The transmitter is factory-calibrated to the range selected and cannot be significantly adjusted to tighten the range closer to the pressure being read for the given application.*

Available Transmitters

- TDR00729: 0-5-inch
- TDR00730: 0-10-inch
- TDR00731: 0-25-inch

Transmitter Calibration

The transmitter is factory-calibrated to a specific pressure range with a 0 to 5-inch, 0 to 10-inch, or 0 to 25-inch w.g.

range being used in most cases. To check calibration and to adjust if necessary, consult the transmitter manufacturer or the factory for specific procedures.

The transmitter outputs a linear, 2-10 Vdc signal representing a differential pressure measurement. With this measurement, the airflow through the fan can be calculated using the following equation:

$$CFM = K * \text{SQRT}(DP)$$

Where: CFM = Airflow (ft³/min.) assuming a standard air density of 0.075 lbm/ft³.

K = A constant factor that is unique for each fan. See "Constant Factor K," p. 141 for more information.

DP = Differential pressure (inches w.g.) being measured by the transmitter.

Significant differences in elevation and/or temperature will affect the density of air. For air at a constant, non-standard density, a field-obtained K factor can be used. Alternatively, the following equation can be used to continuously correct the equation above:

$$ACFM = CFM * \text{SQRT}(0.075/\rho)$$

Where: ACFM = Actual airflow (ft³/min.) corrected for non-standard air density.

ρ = Density (lbm/ft³) of the air at the inlet to the fan.

Note: *Alternative units, including SI, can be used in place of the IP units above although the K-factor must be converted appropriately.*

Setup details are available on the HUB - DOC-107523.

Maintenance

For a typical HVAC environment - especially with upstream filtration - there should be little to no required maintenance. In extreme cases or for mishaps (bearing grease in the taps for example), the flow meter is easily cleanable. The fan inlet airflow measuring system is extremely simple: a few pressure taps, a few fittings, and some tubing. Although unlikely, if any tap were to get clogged, simply disconnect each side of the transmitter and blast air in a reverse direction through the system.

Constant Factor K

The constant factor K is unique for each fan and is primarily a function of the area and other geometric properties of the fan inlet. Pre-engineered factors are available from the factory for fan types where the airflow measurement system is available.

For units produced after March 2021, the K-factor was added to the nameplate on the fan section. Refer to this nameplate for the most accurate information. The table below is for reference only.



Start-Up

Table 45. Constant K Factors — generation 1 DDP fans and generation 2 MI fans

Fan Size (inches)/Type	Fan Class	Fan Name	K-Factor
10.50 AF direct-drive plenum	Any	10 TF, 10 TR, 10 UF, 10 UR	576
12 AF direct-drive plenum	Any	12 TF, 12 TR, 12 UF, 12 UR	945
13.50 AF direct-drive plenum	Any	13 TF, 13 TR, 13 UF, 13 UR	965
15 AF direct-drive plenum	Any	15 TF, 15 TR, 15 UF, 15 UR	1227
16 AF direct-drive plenum	Any	16 TF, 16 TR, 16 UF, 16 UR	1519
18 AF direct-drive plenum	Any	18 TF, 18 TR, 18 UF, 18 UR	1822
20 AF direct-drive plenum	Any	20 TF, 20 TR, 20 UF, 20 UR	2186
22 AF direct-drive plenum	Any	22 TF, 22 TR, 22 UF, 22 UR	2649
24 AF direct-drive plenum	Any	24 TF, 24 TR, 24 UF, 24 UR	3092
27 AF direct-drive plenum	Any	27 TF, 27 TR, 27 UF, 27 UR	4156
30 AF direct-drive plenum	Any	30 TF, 30 TR, 30 UF, 30 UR	4945
12.20 motorized impeller	Any	12 VP, 12 EP, 12 FM	1078
15.70 motorized impeller	Any	15 VP, 15 EP, 15 FM	1747
17.70 motorized impeller	Any	17 VP, 17 EP, 17 FM	2231
19.70 motorized impeller	Any	19 VP, 19 EP, 19 FM	2612
22.00 motorized impeller	Any	22 VP, 22 EP, 22 FM	3233

Table 46. Constant K Factors — generation 2 DDP fans and generation 3 MI fans

Fan Size (inches)/Type	Fan Class	Fan Name	K-Factor
10.50 AF direct-drive plenum	Any	10 UF	598
12 AF direct-drive plenum	Any	12 UF	763
13.50 AF direct-drive plenum	Any	13 UF	910
15 AF direct-drive plenum	Any	15 UF	1181
16 AF direct-drive plenum	Any	16 UF	1441
18 AF direct-drive plenum	Any	18 UF	1688
20 AF direct-drive plenum	Any	20 UF	2136
22 AF direct-drive plenum	Any	22 UF	2649
24 AF direct-drive plenum	Any	24 UF	3092
27 AF direct-drive plenum	Any	27 UF	4156
30 AF direct-drive plenum	Any	30 UF	4810
12.20 motorized impeller	Any	12VP, 12EP, 12FM	1078
13.90 motorized impeller	Any	13VP, 13FM	1375
13.90 motorized impeller	Any	13FM	1141
15.70 motorized impeller	Any	15VP, 15EP, 15FM	1747
17.70 motorized impeller	Any	17VP, 17EP, 17FP, 17FM	2231
19.70 motorized impeller	Any	19 VP, 19EP, 19FP, 19FM	2612

Table 46. Constant K Factors — generation 2 DDP fans and generation 3 MI fans (continued)

Fan Size (inches)/Type	Fan Class	Fan Name	K-Factor
19.70 motorized impeller	Any	19FM	2045
22.00 motorized impeller	Any	22 VP, 22EP, 22FP, 22FM, 22RM	3233

When a single transmitter is supplied in a multiple fan system, one or more fans will be brought back to the transmitter as a manifold and the airflow will represent the total airflow for the system. As a result, the factor should be adjusted as follows:

$$K = N * K\text{-Factor}$$

Where:

K = The final factor to be used for controller programming.

N = The number of active* fans in the system.

*If a fan fails in a multiple fan system where only one transmitter is being supplied, and if the remaining fans will continue to be used, the factor should be reduced accordingly. Additionally, if the inactive fan was included in the manifold back to the transmitter, the tubes from the inactive fan should be temporarily removed and replaced with tubes from an active fan (or simply plugged).

When a transmitter is supplied for each fan, the factor does not need to be adjusted. The resulting airflow will represent single-fan airflow. At the controller level, the individual airflows should be summed to get the total airflow. If a field-provided K-factor is to be used (see below), the measured airflow for the system should be divided by the number of active fans to get a single-fan K-factor.

Field-obtained factors can provide maximum accuracy. To obtain the factor in the field, measure the differential pressure output from the transmitter while measuring the airflow through the system. Once these two values have been measured, simply solve for K using the following equation:

$$K = \text{ACFM} / \text{SQRT}(\text{DP})$$

Where:

K = Field-provided constant factor.

ACFM = Actual airflow (ft³/min.) being measured at the air density being measured.

DP = Differential pressure (inches w.g.) being measured by the transmitter.

CDQ Wheel Start Up

⚠ WARNING

Hazardous Voltage w/Capacitors!

Failure to disconnect power and discharge capacitors before servicing could result in death or serious injury.

Disconnect all electric power, including remote disconnects and discharge all motor start/run capacitors before servicing. Follow proper lockout/tagout procedures to ensure the power cannot be inadvertently energized. For variable frequency drives or other energy storing components provided by Trane or others, refer to the appropriate manufacturer's literature for allowable waiting periods for discharge of capacitors. Verify with a CAT III or IV voltmeter rated per NFPA 70E that all capacitors have discharged.

NOTICE

Equipment Damage!

Failure to follow instruction below could result in rupture disk damage and/or loss of refrigerant. Do NOT exceed the recommended test pressure. Trane is not responsible for equipment damage resulting from excess pressure on the rupture disk.

Note: Do not exceed the maximum rated airflow for the wheel. The pressure drop across the wheel is not to exceed 1.5-inches w.g.

1. Set diameter seals. See "CDQ Seal Adjustment," p. 155.
2. Turn the wheel counter-clockwise (as viewed from the pulley side) by hand to verify that the wheel turns freely through its full rotation.
3. With hands and objects away from moving parts, activate the wheel and confirm the wheel rotation. The correct rotation direction is counter-clockwise as viewed from the pulley side.
4. Verify rotational speed 8-10 rotations per hour. The wheel should be a 1/4 turn in 100-150 seconds.
5. Start and stop the wheel several times to confirm seal adjustment and proper belt tracking on the wheel rim.
6. If the wheel has difficulty starting, confirm seals adjustment and belt tension. See "CDQ Seal Adjustment," p. 155. If belt slips, see "CDQ Drive Belt Adjustment/Replacement," p. 154.

- If the wheel has difficulty starting, turn off the power and inspect for excessive interference between the wheel surface and the four diameter seals. To correct, loosen the diameter seal adjusting screws and back the diameter seals away from the surface of the wheel. Apply power to confirm that the wheel rotates freely. Readjust and tighten the seals according to instructions in "CDQ Seal Adjustment," p. 155.
- Damper actuators (if so equipped): Stroke the actuators to observe full open and full closure of dampers. Adjust the actuator and/or linkage to prevent "over-stroking" so excessive pressure is not placed on the damper at the full open or full closed position.

Energy Wheel Start-up

⚠ WARNING

Toxic Hazards!

Failure to follow instructions below could result in death or serious injury.

Do not use an energy wheel in an application where the exhaust air is contaminated with harmful toxins or biohazards.

⚠ WARNING

Hazardous Voltage w/Capacitors!

Failure to disconnect power and discharge capacitors before servicing could result in death or serious injury.

Disconnect all electric power, including remote disconnects and discharge all motor start/run capacitors before servicing. Follow proper lockout/tagout procedures to ensure the power cannot be inadvertently energized. For variable frequency drives or other energy storing components provided by Trane or others, refer to the appropriate manufacturer's literature for allowable waiting periods for discharge of capacitors. Verify with a CAT III or IV voltmeter rated per NFPA 70E that all capacitors have discharged.

NOTICE

Equipment Damage!

Failure to follow instruction below could result in rupture disk damage and/or loss of refrigerant. Do NOT exceed the recommended test pressure. Trane is not responsible for equipment damage resulting from excess pressure on the rupture disk.

Note: Do not exceed the maximum rated airflow for the wheel. The pressure drop across the wheel is not to exceed 1.25-inches w.g.

- Do not exceed the maximum rated airflow for the wheel. The pressure drop across the wheel is not to exceed 1.25-inches w.g.

- Turn the energy wheel clockwise (as viewed from the pulley side) by hand to verify that the wheel turns freely through its full rotation.
- Confirm that all wheel segments are fully engaged in the wheel frame and that segment retainers are completely fastened (see Figure 165, p. 144).

Figure 165. Completely fasten segment retainers



- With hands and objects away from moving parts, activate the wheel and confirm the wheel rotation. The correct rotation direction is clockwise as viewed from the pulley side.
- Start and stop the wheel several times to confirm seal adjustment and proper belt tracking on the wheel rim. The correct belt tracking is approximately a quarter inch from the outer edge of the rim.

Figure 166. Confirm proper belt tracking on wheel rim

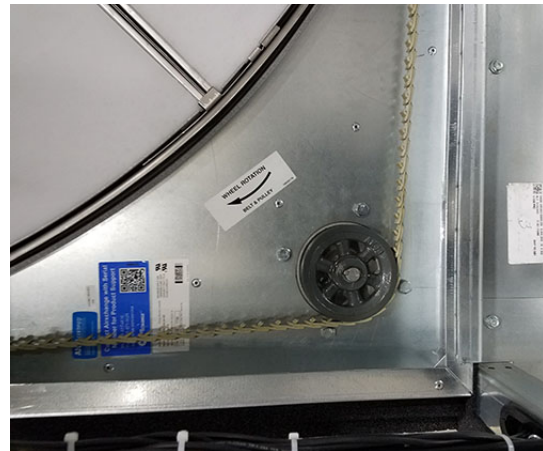

- If the wheel has difficulty starting, turn off the power and inspect for excessive interference between the wheel surface and the four diameter seals. To correct, loosen the diameter seal adjusting screws and back the diameter seals away from the surface of the wheel. Apply power to confirm that the wheel rotates freely.

Readjust and tighten the seals according to instructions in “Energy Wheel Seal Adjustment,” p. 160.

7. Damper actuators (if so equipped): Stroke the actuators to observe full open and full closure of dampers. Adjust the actuator and/or linkage to prevent “over-stroking” so excessive pressure is not placed on the damper at the full open or full closed position.

External Insulating Requirements

The following areas should be specifically addressed, as applicable:

- Supply and return water piping connections
- Supply and return refrigerant piping connections
- Condensate drain lines and connections
- Outdoor-air-intake duct connections
- Discharge duct connections
- Special requirements for low-temperature-air systems
- Electric duct heaters mounted on the fan discharge

Important: *Minimum clearance from combustible materials: 1-inch for first four feet of duct.*



Routine Maintenance

⚠ WARNING

Hazardous Service Procedures!

Failure to follow all precautions in this manual and on the tags, stickers, and labels could result in death or serious injury.

Technicians, in order to protect themselves from potential electrical, mechanical, and chemical hazards, **MUST** follow precautions in this manual and on the tags, stickers, and labels, as well as the following instructions: Unless specified otherwise, disconnect all electrical power including remote disconnect and discharge all energy storing devices such as capacitors before servicing. Follow proper lockout/tagout procedures to ensure the power can not be inadvertently energized. When necessary to work with live electrical components, have a qualified licensed electrician or other individual who has been trained in handling live electrical components perform these tasks.

⚠ WARNING

Rotating Components!

Failure to disconnect power before servicing could result in rotating components cutting and slashing technician which could result in death or serious injury.

During installation, testing, servicing and troubleshooting of this product it may be necessary to work with live and exposed rotating components. Have a qualified or licensed service individual who has been properly trained in handling exposed rotating components, perform these tasks.

Maintenance Checklist

Table 47. Maintenance checklist

After 48 hours of operation
<input type="checkbox"/> For belt-drive fans, the belts have acquired their permanent set. Readjust but do not overtighten.
Every week
<input type="checkbox"/> Observe unit weekly for any change in running condition and unusual noise.
Every month
<input type="checkbox"/> Clean or replace air filters if clogged or dirty; change bag filters when pressure drop is 1-in. w.g. See "Filters," p. 163.
<input type="checkbox"/> Permanent filters located in outdoor air intake hoods should be cleaned monthly. This time frame should be altered if needed due to seasonal issues, i.e., high pollen levels in the spring or leaves in the fall.
Every three to six months
<input type="checkbox"/> Check motor bracket torque. See Table 48, p. 161 for torque requirements.
<input type="checkbox"/> Inspect and clean drain pans. See "Drain Pans," p. 149.
<input type="checkbox"/> Tighten electrical connections.
<input type="checkbox"/> Inspect coils for dirt build-up. See "Coils," p. 147.
<input type="checkbox"/> Clean moisture eliminator with high pressure sprayer. Remove pollen in the spring and leaves in the fall. See "Moisture Eliminator," p. 163.
Every year
<input type="checkbox"/> Inspect the unit casing for corrosion. If damage is found, clean and repaint.
<input type="checkbox"/> Clean the fan wheels and shaft. See "Fans," p. 161.
<input type="checkbox"/> Inspect and clean drain pans.
<input type="checkbox"/> Check damper linkages, set screws, and blade adjustment. Clean, but do not lubricate, the nylon damper rod bushings.
<input type="checkbox"/> Clean damper operators.
<input type="checkbox"/> Inspect electrical components and insulation.
<input type="checkbox"/> Inspect wiring for damage.
<input type="checkbox"/> Rotate the fan wheel and check for obstructions. The wheel should not rub. Adjust the center if necessary.
<input type="checkbox"/> Lubricate motor bearings in accordance with motor manufacturer's recommendations (see "Motor Bearing Lubrication," p. 162).
<input type="checkbox"/> Check condition of gasketing and insulation around unit, door and dampers.
<input type="checkbox"/> Examine flex connections for cracks or leaks. Repair or replace damaged material.

Air-to-Air Plate Heat Exchangers

⚠ WARNING

Hazardous Voltage!

Failure to disconnect power before servicing could result in death or serious injury.

Disconnect all electric power, including remote disconnects before servicing. Follow proper lockout/tagout procedures to ensure the power can not be inadvertently energized. Verify that no power is present with a voltmeter.

⚠ WARNING

Hazardous Chemicals!

Failure to follow this safety precaution could result in death or serious injury. Coil cleaning agents can be either acidic or highly alkaline and can burn severely if contact with skin or eyes occurs.

Handle chemical carefully and avoid contact with skin. ALWAYS wear Personal Protective Equipment (PPE) including goggles or face shield, chemical resistant gloves, boots, apron or suit as required. For personal safety refer to the cleaning agent manufacturer's Materials Safety Data Sheet and follow all recommended safe handling practices.

To clean air-to-air heat plate exchangers:

1. Disconnect all electrical power to the unit.
2. Wearing the appropriate personal protective equipment, use a soft brush to remove loose debris from the faces of the exchanger.
3. Install a block-off to prevent spray from going through the exchanger and into a dry section of the unit and/or system ductwork.
4. Mix a high-quality coil cleaning detergent with water according to the manufacturer's instructions.

Note: If the detergent is strongly alkaline after mixing (PH 8.5 or higher), it must contain an inhibitor. Follow the cleaning solution manufacturer's instructions regarding the use of the product.
5. Place the mixed solution in a garden pump-up sprayer or high-pressure sprayer. If a high pressure sprayer is used:
 - a. Maintain minimum nozzle spray angle of 15 degrees.
 - b. Spray perpendicular to the exchanger face.
 - c. Use a 40 degree nozzle at least 6 inches from the face.
 - d. Do not exceed 1450 psi.
6. Spray the lower sides of the exchanger first, then the upper sides.
7. Thoroughly rinse both sides of the exchanger and the drain pan with cool, clean water.

8. Repeat steps 6 and 7 as necessary.
9. Straighten any plate fins that may have been damaged during the cleaning process.
10. Confirm the drain line is open following the cleaning process.
11. Allow the unit to dry thoroughly before putting it back into service.
12. Replace all panels and parts and restore electrical power to the unit.
13. Be careful any contaminated material does not contact other areas of the unit or building. Properly dispose of all contaminated materials.

Coils

All coils should be kept clean to maintain maximum performance.

Steam and Water Coils

⚠ WARNING

Hazardous Voltage!

Failure to disconnect power before servicing could result in death or serious injury.

Disconnect all electric power, including remote disconnects before servicing. Follow proper lockout/tagout procedures to ensure the power can not be inadvertently energized. Verify that no power is present with a voltmeter.

⚠ WARNING

Hazardous Chemicals!

Failure to follow this safety precaution could result in death or serious injury. Coil cleaning agents can be either acidic or highly alkaline and can burn severely if contact with skin or eyes occurs.

Handle chemical carefully and avoid contact with skin. ALWAYS wear Personal Protective Equipment (PPE) including goggles or face shield, chemical resistant gloves, boots, apron or suit as required. For personal safety refer to the cleaning agent manufacturer's Materials Safety Data Sheet and follow all recommended safe handling practices.

To clean steam and water coils:

1. Disconnect all electrical power to the unit.
2. Wearing the appropriate personal protective equipment, use a soft brush to remove loose debris from both sides of the coil.
3. Install a block-off to prevent spray from going through the coil and into a dry section of the unit and/or system ductwork.
4. Mix a high-quality coil cleaning detergent with water according to the manufacturer's instructions.



Routine Maintenance

Note: If the detergent is strongly alkaline after mixing (PH 8.5 or higher), it must contain an inhibitor. Follow the cleaning solution manufacturer's instructions regarding the use of the product.

5. Place the mixed solution in a garden pump-up sprayer or high-pressure sprayer. If a high pressure sprayer is to be used:
 - a. Maintain minimum nozzle spray angle of 15 degrees.
 - b. Spray perpendicular to the coil face.
 - c. Keep the nozzle at least 6 inches from the coil.
 - d. Do not exceed 600 psi.
6. Spray the leaving air side of the coil first, then the entering air side.
7. Thoroughly rinse both sides of the coil and the drain pan with cool, clean water.
8. Repeat step 6 and step 7 as necessary.
9. Straighten any coil fins that may have been damaged during the cleaning process.
10. Confirm the drain line is open following the cleaning process.
11. Allow the unit to dry thoroughly before putting it back into service.
12. Replace all panels and parts and restore electrical power to the unit.
13. Be careful any contaminated material does not contact other areas of the unit or building. Properly dispose of all contaminated materials.

Refrigerant Coils

⚠ WARNING

Hazardous Pressures!

Failure to follow instructions could result in coil bursting, which could result in death or serious injury. Coils contain refrigerant under pressure. To avoid excessive pressure in the coil, do not exceed 150°F coil cleaning solution temperature.

⚠ WARNING

Hazardous Voltage!

Failure to disconnect power before servicing could result in death or serious injury. Disconnect all electric power, including remote disconnects before servicing. Follow proper lockout/tagout procedures to ensure the power can not be inadvertently energized. Verify that no power is present with a voltmeter.

⚠ WARNING

Hazardous Chemicals!

Failure to follow this safety precaution could result in death or serious injury. Coil cleaning agents can be either acidic or highly alkaline and can burn severely if contact with skin or eyes occurs.

Handle chemical carefully and avoid contact with skin. **ALWAYS** wear Personal Protective Equipment (PPE) including goggles or face shield, chemical resistant gloves, boots, apron or suit as required. For personal safety refer to the cleaning agent manufacturer's Materials Safety Data Sheet and follow all recommended safe handling practices.

To clean refrigerant coils:

1. Disconnect all electrical power to the unit.
2. Wearing the appropriate personal protective equipment, use a soft brush to remove loose debris from both sides of the coil.
3. Install a block-off to prevent spray from going through the coil and into a dry section of the unit and/or system ductwork.
4. Mix a high-quality coil cleaning detergent with water according to the manufacturer's instructions.

Note: If the detergent is strongly alkaline after mixing (PH 8.5 or higher), it must contain an inhibitor. Follow the cleaning solution manufacturer's instructions regarding the use of the product.

5. Place the mixed solution in a garden pump-up sprayer or high-pressure sprayer. If a high pressure sprayer is to be used:
 - a. Maintain minimum nozzle spray angle of 15 degrees.
 - b. Spray perpendicular to the coil face.
 - c. Keep the nozzle at least 6-inches from the coil.
 - d. Do not exceed 600 psi.
6. Spray the leaving air side of the coil first, then the entering air side.
7. Thoroughly rinse both sides of the coil and the drain pan with cool, clean water.
8. Repeat step 6 and step 7 as necessary.
9. Straighten any coil fins damaged during the cleaning process.
10. Confirm the drain line is open following the cleaning process.
11. Allow the unit to dry thoroughly before putting it back into service.
12. Replace all panels and parts and restore electrical power to the unit.
13. Be careful any contaminated material does not contact other areas of the unit or building. Properly dispose of all contaminated materials and cleaning solution.

Coil Winterization

Water coil winterization procedures consist primarily of draining water from the coil before the heating season. Trane recommends flushing the coil with glycol if coils will be exposed to temperatures below 35 degrees.

NOTICE

Coil Freeze-Up!

Failure to follow instruction below could result in equipment damage.

Drain and vent coils when not in use. Trane recommends glycol protection in all possible freezing applications. Use a glycol approved for use with commercial cooling and heating systems and copper tube coils.

Install field-fitted drains and vents to permit winterization of coils not in use and to assist in evacuating air from the water system during start-up. If draining is questionable because of dirt or scale deposits inside the coil, fill the coil with glycol before the heating season begins.

Individual coil types determine how to properly winterize the coil. To determine the coil type find the **Service Model No of Coil** on the coil section nameplate. The coil type is designated by the second and third digits on that model number. For example, if the model number begins with **DUWB**, the coil type is UW; if the model number begins with **DW0B**, the coil type is W.

Note: *On many unit sizes, there are multiple coils in the coil section. Be sure to winterize all coils in a given coil section.*

To winterize type D1, D2, WL, LL, UA, UW, UU, W, WD, 5D, and 5W coils:

1. Remove the vent and drain plugs.
2. Blow the coil out as completely as possible with compressed air.
3. Fill and drain the coil several times with full strength glycol so that it mixes thoroughly with the water retained in the coil.
4. Drain the coil out as completely as possible.
5. To ensure no water remains in the coil, do not replace the vent and drain plugs until the coils are put back into service.

Note: *Use care in removing header plugs from Type P2, P4, and P8 coils. Over-torquing may result in twisted tubes.*

Moisture Purge Cycle

By its very nature, any HVAC unit with a cooling coil serves as a dehumidifier, reducing the surrounding air's ability to hold water vapor as its temperature falls. This normally doesn't present a problem when the unit is running. However, when the fan stops, water vapor condenses on the cold metal surfaces inside the air handler and remains there until the air warms sufficiently to re-evaporate it. This

damp, dark environment — though temporary— can encourage the growth of mold, mildew, and other microbial contaminants.

Providing a moisture purge cycle 15 to 30 minutes after shutdown disperses the cold, humid air inside the air-handling.

Drain Pans

⚠ WARNING

Hazardous Voltage!

Failure to disconnect power before servicing could result in death or serious injury.

Disconnect all electric power, including remote disconnects before servicing. Follow proper lockout/tagout procedures to ensure the power can not be inadvertently energized. Verify that no power is present with a voltmeter.

⚠ WARNING

No Step Surface!

Failure to follow instruction below could result in death or serious injury.

Do not walk on the sheet metal drain pan. Walking on the drain pan could cause the supporting metal to collapse and result in the operator/technician falling.

The condensate drain pan and drain line must be checked to assure the condensate drains as designed. This inspection should occur a minimum of every six months or more often as dictated by operating experience.

If evidence of standing water or condensate overflow exists, identify and remedy the cause immediately. See "Troubleshooting," p. 166 for possible causes and solutions.

To clean drain pans:

1. Disconnect all electrical power to the unit.
2. Wearing the appropriate personal protective equipment, remove any standing water.
3. Scrape solid matter off of the drain pan.
4. Vacuum the drain pan with a vacuum device that uses high efficiency particulate arrestance (HEPA) filters with a minimum efficiency of 99.97 percent at 0.3 micron particle size.
5. Thoroughly clean any contaminated area(s) with a mild bleach and water solution or an EPA-approved sanitizer specifically designed for HVAC use.
6. Immediately rinse the affected surfaces thoroughly with fresh water and a fresh sponge to prevent potential corrosion of metal surfaces.
7. Allow the unit to dry completely before putting it back into service.



Routine Maintenance

8. Be careful any contaminated material does not contact other areas of the unit or building. Properly dispose of all contaminated materials and cleaning solution.

CDQ Desiccant Dehumidification Wheel

CDQ Cleaning

If there is dirt or dust buildup in the wheel, clean the wheel using the following procedure:

Vacuuming the Wheel

1. Disconnect all power.
2. Using a standard shop vacuum, vacuum any debris from both faces of the wheel. Slowly work around the entire face of the wheel to complete the procedure. Do not damage wheel face by excessive pressure of the vacuum nozzle on the wheel face.
3. Using 20 psig clean dry air, and a small air nozzle, blow air through one face of the wheel. At a similar location on the opposite side of the wheel, gently apply a shop vacuum to "receive" any remaining debris exiting the wheel.

In most instances this should adequately clean the wheel. In the event the wheel is subject to an aerosol, smoke or other material that coats the wheel, it can be washed with water and/ or a mild detergent. The desiccant wheel can be washed thoroughly without affecting the performance of the wheel. The wheel will simply dry out following a washing procedure and resume dehumidification without any deviation in performance.

If the desiccant wheel can be easily removed from the cassette or unit, it is recommended to do so to facilitate the washing process. However, in most cases, it is impractical to remove larger wheels and therefore, the washing procedure must take place within the air handling unit and provisions need to be made to collect the runoff water from the bottom of the unit.

Washing the Wheel

1. Disconnect all power.
2. Shield or remove all electrical components with plastic sheeting. Shield the bearing with plastic sheeting. Precautions should be taken to ensure the motor windings and capacitor do not get wet.
3. Ensure that an adequate drainage system exists to collect runoff water from the bottom of the unit.
4. Using standard pressure water (do not use a high pressure washer) and working from the lower half of the wheel, wash the wheel with a standard "garden" nozzle to flush any debris trapped within the flutes of the wheel. Minimize water contact with the seals. Wash from one side and vacuum up water from the other side with a wet vacuum.

5. Once the entire process side is adequately washed, rotate the wheel one half turn and wash the section that was at the top.
6. After washing, there will be a temporary derate in performance as the wheel dries out. To expedite the dry out time, regeneration preheat should be activated if it was provided.

Cleaning the Motor

⚠ WARNING

Hazardous Voltage!

Failure to disconnect power before servicing could result in death or serious injury.

Disconnect all electric power, including remote disconnects before servicing. Follow proper lockout/tagout procedures to ensure the power can not be inadvertently energized. Verify that no power is present with a voltmeter.

Disconnect all electrical power, then use a vacuum cleaner and brush to remove accumulated material from the CDQ wheel motor. The use of spray aerosol cleaners is not recommended. Examine the motor monthly for debris accumulation.

Cleaning the Module

1. Disconnect all electrical power.
2. Use a vacuum cleaner to remove dust and debris from the module surfaces.
3. If needed, use a detergent solution to remove grease, oil, or other stubborn deposits from module surfaces. Follow the manufacturer's instructions regarding use of the product.
4. Rinse any cleaning product thoroughly from the module walls. The use of a water stream from a garden hose or high pressure washer is not recommended. Saturation of the wall panel insulation could result in potential microbial growth.
5. Examine the module monthly for material build-up on the wall surfaces.

CDQ Bearings/Motor/Belts

CDQ Bearing and Motor Lubrication

The wheel gear motor bearings are pre-lubricated at the manufacturer and do not require re-lubrication. Wheels smaller than 8500 cfm, 66-inches in diameter, have a permanently sealed inboard bearing and need no maintenance. Larger wheels come equipped with a external flanged bearing that should be greased annually.

CDQ Drive Belt Tension

The drive belt is a link stretch belt designed to provide tension throughout the life of the belt. Inspect the belt annually for proper tracking and tension. A properly

tensioned belt will turn the wheel immediately, with no visible slippage, when power is applied. If belt needs tensioning, see “CDQ Drive Belt Adjustment/Replacement,” p. 154.

CDQ Bearing Replacement

⚠ WARNING

Hazardous Voltage!

Failure to disconnect power before servicing could result in death or serious injury.

Disconnect all electric power, including remote disconnects before servicing. Follow proper lockout/tagout procedures to ensure the power can not be inadvertently energized. Verify that no power is present with a voltmeter.

CDQ Internal Bearing Replacement

Prepare wheel for removal of old bearing and installation of new bearing.

1. Remove belt from motor and wheel.
2. Support wheel with wooden blocks on both sides of the wheel.

Figure 167. Wooden blocks support wheel

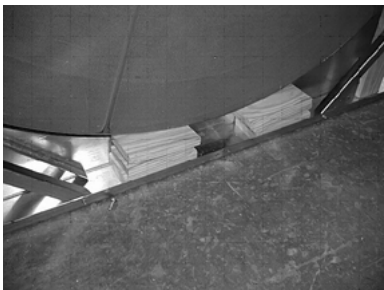

3. Make sure the wheel is secure. The short posts are removed first.

Figure 168. Remove short posts first

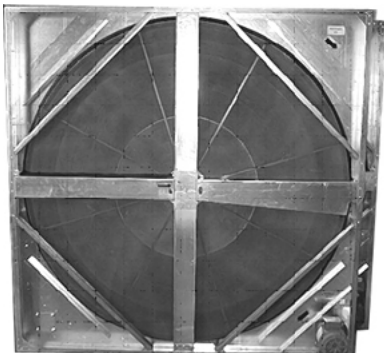

4. To prevent wheel from flipping out, cut two 1-inch x 4-inch boards for placement across the face and behind the lip and corner braces on the cassette.

Figure 169. Prevent wheel from flipping out with boards

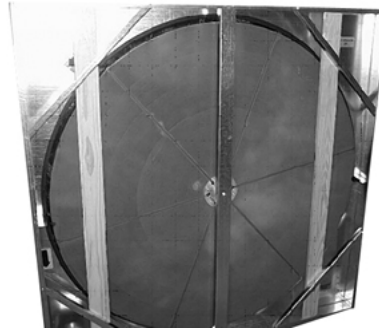

5. Remove the post mounting screws or bolts at both ends of the long post.

Figure 170. Remove post mounting screws



6. Remove the shaft bolt.

Figure 171. Remove shaft bolt

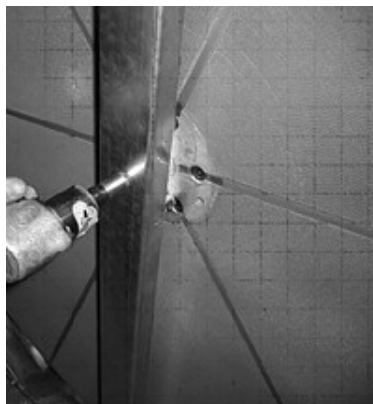

7. Remove the post.
8. Remove the snap ring from the shaft.

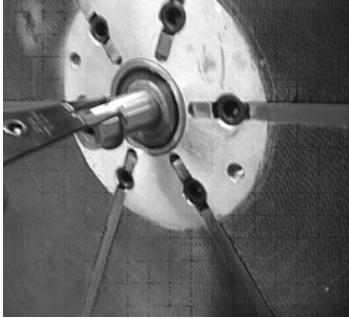
Figure 172. Remove snap ring

9. Remove shaft bolt, post and snap ring from opposite side using the same procedure. Remove shaft, being careful not to damage it. You may want to install a short bolt in the end of the shaft and tap the bolt to remove shaft.
10. The old bearing is removed by tapping it from the back using a rod or punch passed through the other bearing. It is best to use brass or other soft metal, but if bearing is being replaced, it is okay to use a steel rod. Gently work around the race with a series of gentle taps. Using excessive force can cock the bearing and make removal difficult and/or damage the aluminum hub. Once one bearing is out, go to the other side and repeat procedure to remove the other bearing.
11. Clean the hub and new bearing races before installing.
12. Gently tap the outer race of the new bearings into the hub using a hammer, making sure that the bearing is not cocked. It is best to alternate to opposite sides of the race as shown in the two pictures at right. Do not strike the inner race of the bearing or it may be damaged.

Figure 173. Tap outer race of new bearing, alternating sides

13. Repeat the procedure for the other bearing.
14. Install one snap ring on the shaft and gently slide the shaft through the bearings. It may be necessary to tap it gently with a hammer.
15. After the shaft is through the bearings and snap ring is against the inner race, install the other snap ring.
16. Install the long post on one side and re-install the shaft bolt.
17. Install the long post on the other side and re-install the shaft bolt.
18. Install the short posts.
19. Check the wheel for rotation and insure that it is centered in the cassette. It may be necessary to loosen the shaft bolts and adjust the wheel so that it is equidistant from posts on both sides.

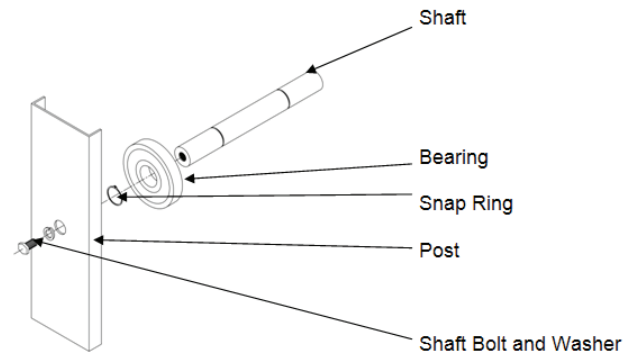
Figure 174. Exploded view of internal bearing and shaft assembly (no hub shown)

20. Install the belt.
21. Start up unit and check wheel for clearance. Seals on the short posts may have to be adjusted for proper sealing.

CDQ External Bearing Replacement

Prepare wheel for removal of old bearing and installation of new bearing.

1. Remove belt from motor and wheel.

- Support wheel with wooden blocks on both sides of the wheel.

Figure 175. Wooden blocks support wheel

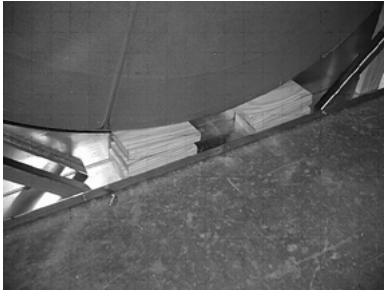

- Remove cover plate from bearing housing if present.

Figure 176. Remove cover plate

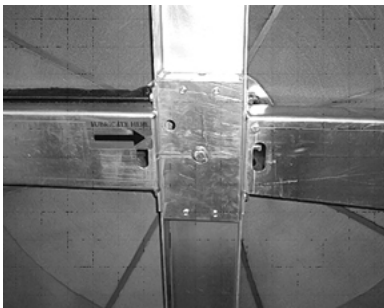

- Remove the bolt and washer from the end of the shaft.

Figure 177. Remove bolt and washer from shaft

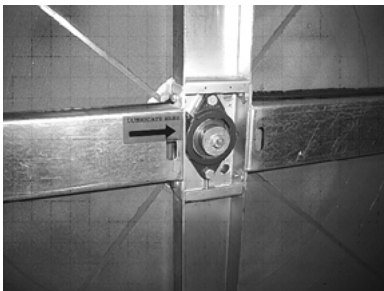

- Loosen the set screws in the bearing inner race.

Figure 178. Loosen set screws



- Remove the bolts securing the bearing to the cassette.

Figure 179. Remove bolts securing bearing

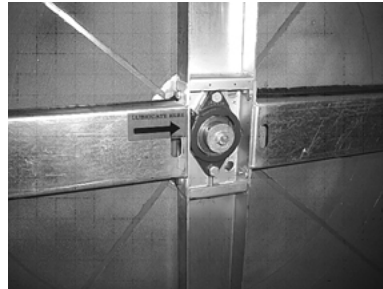

- Remove the bearing. Use a bearing puller if necessary.
- Clean shaft and install new bearing on shaft, insuring that set screws line up with flats on the shaft.
- Install bearing mounting bolts. It may be necessary to move wheel up or down to align bolts. The easiest method is to apply pressure at the top of the wheel. Using a 1-foot by 1-foot square of 1/2-inch thick plywood on the face will spread the force enough to prevent damage to the media face while pushing on the top of the wheel. The other method of lifting the wheel is to use a pry bar at the bottom, taking care to only apply force at a spoke to prevent bending the band.

Figure 180. Install bearing mounting bolts

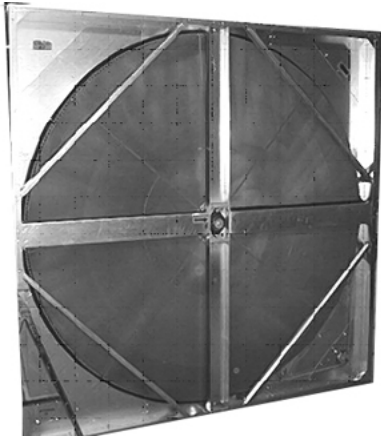

10. Tighten the bearing mounting bolts.
11. Check alignment of the set screws and tighten to the specifications provided in the literature with the bearing.
12. Rotate the wheel and make sure that it is aligned in the cassette so that the face is equidistant from each post. If not, loosen the bearing mounting bolts and adjust as necessary. Flange bearing units have jack bolts. See [Figure 181, p. 154](#).

Figure 181. Typical flange bearing, shaft and hub assembly

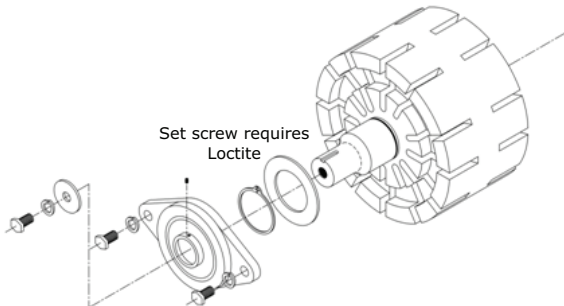

13. Pillow block bearing units require shims to adjust the bearing up or down. See [Figure 182, p. 154](#). Retighten bearing mounting bolts once alignment is correct.
14. Install bearing cover plates. Remove blocks supporting wheel. Install belts.

Figure 182. Typical pillow block bearing, shaft and hub assembly

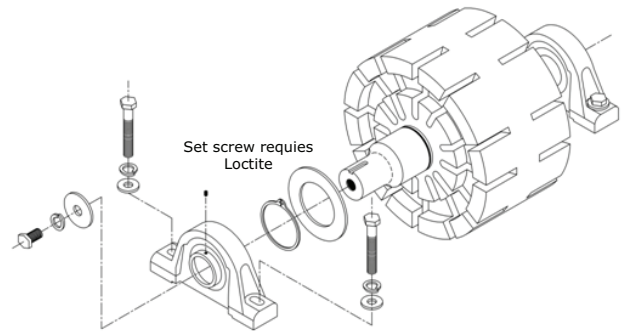

CDQ Drive Belt Adjustment/ Replacement

The CDQ wheel uses a link belt that has no tension devices that need adjustment. Tension the belt by adjusting the number to links in the belt. If the belt becomes too loose it can be tightened by removing a link from the belt.

⚠ WARNING

Hazardous Voltage!
Failure to disconnect power before servicing could result in death or serious injury.
Disconnect all electric power, including remote disconnects before servicing. Follow proper lockout/tagout procedures to ensure the power can not be inadvertently energized. Verify that no power is present with a voltmeter.

CDQ Belt Tension

1. Disconnect all power to the desiccant wheel.
2. Slip belt off of drive pulley.
3. Hold the belt with tabs facing outward as shown in , twist tab and push through one link.

Figure 183. Hold belt with tabs facing outward



4. Twist the next tab and push through the two links as shown in Figure 184, p. 155.

Figure 184. Twist and push through links

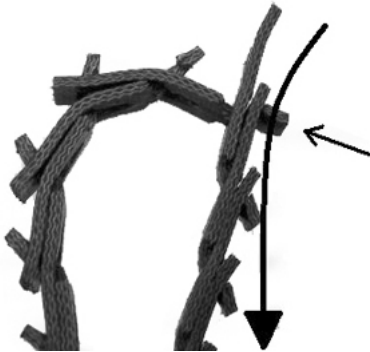

5. Remove one link.
6. Reconnect the belt as shown in Figure 185, p. 155.
 - a. Push tab through
 - b. Align belt
 - c. Flex second tab through

Figure 185. Reconnect the belt

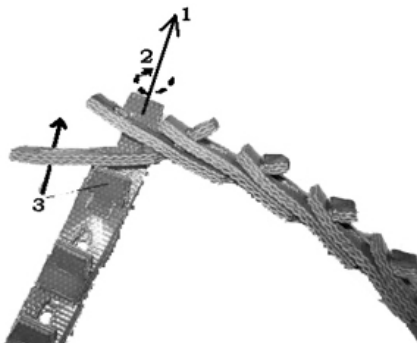

CDQ Seal Adjustment

Neoprene brush seals are located on both sides of the cassette around the wheel perimeter and the center diameter posts. The seals are designed to come in contact with the wheel and require no maintenance other than adjustment. The seals consist of a metal and neoprene clip that grips to the metal posts or panels. These clips can be manually adjusted.

Figure 186. Seals are located around wheel perimeter and center of diameter posts

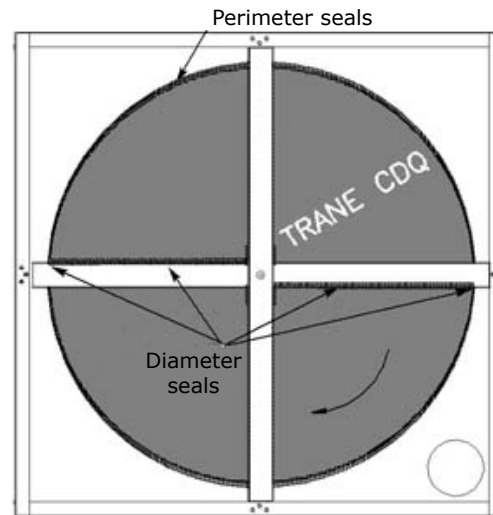

To minimize air that bypasses the wheel the perimeter seals should be adjusted such that air gaps are not visible around the wheel. Do not over compress the seal against the perimeter as this may cause the wheel not to turn or overload the motor. To minimize air the leaks from one side to the next the diameter seals should be adjusted to come in full contact with the wheel face.

Figure 187. Adjust seals to fully contact wheel face to minimize leaks

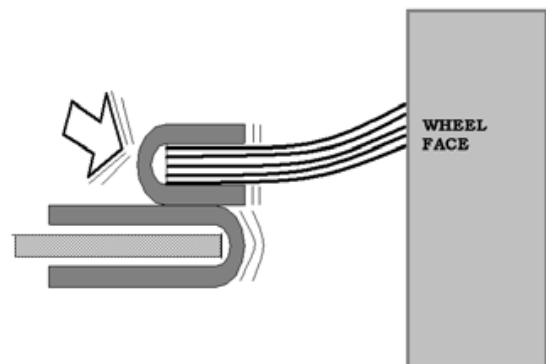

CDQ Drive Motor and Pulley Replacement

1. Disconnect all electrical power.
2. Remove the belt from the pulley and temporarily position it around the wheel rim.
3. Measure and record the distance from the inner edge of the pulley to the mounting wall.
4. Loosen the set screw in the wheel drive pulley using an Allen wrench and remove the pulley from the motor drive shaft.
5. While supporting the weight of the drive motor in one hand, loosen and remove the four mounting bolts.



Routine Maintenance

6. Install a replacement motor with the hardware kit supplied.
7. Install the pulley and adjust it to the distance recorded in the previous step.
8. Tighten the set screw to the drive shaft.
9. Stretch the belt over the pulley and engage it in the groove.

Energy Wheels

⚠ WARNING

Hazardous Voltage!

Failure to disconnect power before servicing could result in death or serious injury.

Disconnect all electric power, including remote disconnects before servicing. Follow proper lockout/tagout procedures to ensure the power can not be inadvertently energized. Verify that no power is present with a voltmeter.

NOTICE

Energy Wheel Damage!

Failure to follow instructions below could result in wheel damage.

Do not use acid based cleaners, aromatic solvents, steam, or temperatures in excess of 170°F to clean the wheel.

Do not use a pressure washer to clean energy wheel segments.

Energy Wheel Cleaning

Disconnect all electrical power, then use a vacuum or brush to remove accumulated material from the face of the wheel. Examine the energy wheel monthly for material build-up on the wheel.

If more aggressive cleaning is needed, segment removal may be required.

1. Wash the segments or the wheel in a five-percent solution of non-acid-base coil cleaner (part no. CHM00021 at your local Trane parts center) or in an alkaline detergent and warm water.
2. Soak the segments in the solution until grease, oil, and tar deposits are loosened.
3. Before removing the cleaner, rapidly run your fingers across the surface of the segments to separate the polymer strips for better cleaning actions.
4. Rinse the dirty solution from the segments and remove excess water before re-installing the segments in the wheel. Note that some permanent staining of the desiccant may remain but is not harmful to performance.

In reasonably clean office or school buildings, cleaning with coil cleaner solution may not be required for several years.

If the energy wheel is exposed to air streams containing, for example, high levels of occupant tobacco smoke, cooking facility exhaust air, or oil-based aerosols found in machine shop areas, annual cleaning may be required to remove these contaminants and restore performance.

High maintenance applications like these may benefit from keeping a spare set of clean segments on hand. This allows for rapid change-out of clean segments with minimal downtime. The dirty segments can then be cleaned at a convenient time.

Cleaning the Energy Wheel Motor

⚠ WARNING

Hazardous Voltage!

Failure to disconnect power before servicing could result in death or serious injury.

Disconnect all electric power, including remote disconnects before servicing. Follow proper lockout/tagout procedures to ensure the power can not be inadvertently energized. Verify that no power is present with a voltmeter.

Disconnect all electrical power, then use a vacuum cleaner and brush to remove accumulated material from the energy wheel motor. The use of spray aerosol cleaners is not recommended. Examine the motor monthly for debris accumulation.

Cleaning the Module

1. Disconnect all electrical power.
2. Use a vacuum cleaner to remove dust and debris from the module surfaces.
3. If needed, use a detergent solution to remove grease, oil, or other stubborn deposits from module surfaces. Follow the manufacturer's instructions regarding use of the product.
4. Rinse any cleaning product thoroughly from the module walls. The use of a water stream from a garden hose or high pressure washer is not recommended. Saturation of the wall panel insulation with potential microbial growth or damage to the energy wheel could occur.
5. Examine the module monthly for material build-up on the wall surfaces.

Segment Removal and Replacement

Segment Removal - 900-15,000 wheel cfm

For unit sizes 3 to 8, the energy wheel module is equipped with only one access panel and the entire energy wheel cassette slides out through the door for maintenance. For unit sizes 10 to 50, the energy wheel module is equipped with four access doors and the wheel segments are

removable. Wheel segments are secured to the wheel frame by a segment retainer, which pivots on the wheel rim and is held in place by a segment retaining catch.

1. Disconnect all electrical power.
2. Unlock the two segment retainer brackets, one on each side of the selected segment opening (see [Figure 188, p. 157](#)).
3. Remove the segment from the wheel frame. It may be necessary to gently pry the segment out of the wheel with a screwdriver.
4. Pull the segment up and out of the wheel frame (see [Figure 189, p. 157](#)).
5. Close any open segment retainers prior to rotating the wheel. Failure to close any retainer may damage the retainer, seals, or segments.
6. Slowly rotate the wheel by hand 180 degrees and repeat the process to remove the second segment.
7. Rotate the wheel 90 degrees by hand and remove the third segment.
8. Rotate the wheel 180 degrees by hand and remove the fourth segment. Rotating the wheel in this manner keeps the wheel balanced while removing the segments.
9. Continue this procedure to remove all the segments.

Segment Replacement - 900-15,000 wheel cfm

⚠ WARNING

Hazardous Voltage!

Failure to disconnect power before servicing could result in death or serious injury.

Disconnect all electric power, including remote disconnects before servicing. Follow proper lockout/tagout procedures to ensure the power can not be inadvertently energized. Verify that no power is present with a voltmeter.

1. Disconnect all electrical power.
2. Unlock the two segment retainers, one for each side of the selected segment opening (see [Figure 188, p. 157](#)).
3. With the embedded stiffener facing the motor side, insert the nose of the segment between the hub plates.
4. Holding the segment by the two outer corners, press the segment toward the center of the wheel and inward against the spoke flanges. If hand pressure does not fully seat the segment, insert the flat tip of a screwdriver between the wheel rim and outer corners of the segment and apply downward force while guiding the segment into place.
5. Close and latch each segment retainer under the segment retaining catch.

6. Slowly rotate the wheel 180 degrees by hand. Install the second segment opposite the first for counterbalance.
7. Rotate the two installed segments 90 degrees by hand to balance the wheel while the third segment is installed.
8. Rotate the wheel 180 degrees by hand to install the fourth segment opposite the third.
9. Repeat this sequence with the remaining four segments.

Replacing the segments with a spare set can be accomplished more quickly. Remove the dirty segment, replace it with a clean segment, then move to the next segment. The 180/90/180-degree rotation procedure is not necessary.

Figure 188. Unlock the segment retainers



Figure 189. Pull the segment up and out of the wheel frame to remove

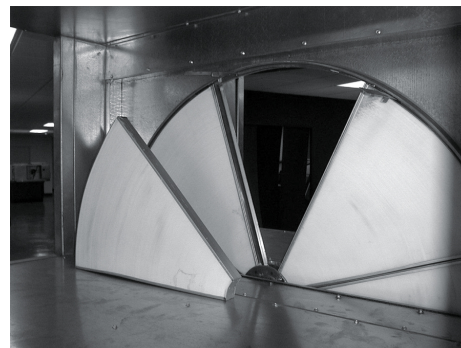

Segment Removal - 17,500 and higher wheel cfm

For energy wheel applications requiring 17,500 cfm and higher, wheel segments with satellite sections are used (see [Figure 190, p. 158](#)).

Removal Procedure for Outer Segments

⚠ WARNING

Hazardous Voltage!
 Failure to disconnect power before servicing could result in death or serious injury. Disconnect all electric power, including remote disconnects before servicing. Follow proper lockout/tagout procedures to ensure the power can not be inadvertently energized. Verify that no power is present with a voltmeter.

Note: Install and remove all segments at location indicated by arrow in Figure 190, p. 158.

Figure 190. Install and remove segments in the order shown

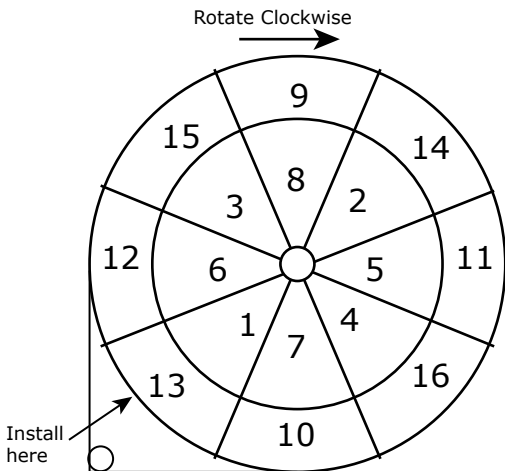

1. Disconnect all electrical power.
2. Align outer segment with wheel drive pulley. Secure pulley and belt with vise grip to prevent rotation (see Figure 191, p. 158).

Figure 191. Secure pulley and belt with vise grip to prevent wheel rotation



3. Insert flat tipped screwdriver between rim and segment retainer latch. Rotate screwdriver to release latch from under catch.
4. Rotate latch 90 degrees from rim. Remove forked segment retainers.

5. Insert screwdriver tip between corners of segment and spoke. Gently pry ends of segment part way out. Grasp one end of segment and lift straight out.
6. Remove vise grip. Repeat steps 1 through 5 for each segment in the order shown in Figure 190, p. 158.

Removal Procedure for Inner Segments

Remove inner segments in the order shown in Figure 190, p. 158 as follows:

1. Align inner segment with wheel drive pulley. Secure pulley and belt with vise grip to prevent rotation (see).
2. Support segment with one hand while removing 1/4-20 flat head retaining screw in hub with 5/32-inch Allen wrench.
3. With weight of segment resting on lower spoke, carefully slide segment out from between hub plates.
4. Being careful to balance segment on lower spoke with one hand, grasp nose of segment with other hand and remove from wheel.
5. Reinsert 1/4-20 screws in segment nose bracket to avoid loss.
6. Remove vise grip. Repeat steps 1 through 5 for each segment in the order shown in Figure 190, p. 158.

Segment Replacement - 17,500 and higher wheel cfm

Installation Procedure for Inner Segments

Note: Install and remove all segments at location indicated by arrow in Figure 190, p. 158.

1. Rotate the wheel clockwise to align the center of a spoke opening with the pulley. Secure pulley and belt with vise grip to prevent wheel rotation (see).
2. Remove 1/4-20 flat head screw from segment nose bracket.
3. Center and rest segment on lower spoke. Slide segment on spoke until nose bracket contacts stop in hub plate. Insert screw and tighten until screw is firmly seated.
4. Holding wheel to prevent rotation, remove vise grip. Rotate wheel clockwise to install segments in the order shown in Figure 190, p. 158.
5. Secure pulley. Repeat steps 2 through 4 until all inner segments are installed.

Installation Procedure for Outer Segments

1. Align segment opening with pulley. Secure pulley and belt with vise grip to prevent rotation (see Figure 191, p. 158).

2. Rotate outer segment retainer latch, located at end of spokes, 90 degrees from rim and remove two forked outer segment retainers.
3. Install outer segment by starting lower end in position and pressing straight in against four corners. Sharp rap with heel of hand will assist entry when needed.

Note: Only reinstall segment retainer between adjacent installed segments.

4. Rotate both retainer latches to closed position to prevent interference with bearing support beam while rotating wheel by hand.
5. Repeat steps 1 through 4 in the order shown in [Figure 190, p. 158](#) until all outer segments are in place. Make certain all retainer latches are latched in place under catch.

Energy Wheel Bearings/Motor/Belts

The wheel drive motor and wheel support shaft bearings are permanently lubricated and no further lubrication is necessary.

Energy Wheel Bearing/Drive Belt

The drive belt is a urethane stretch belt designed to provide constant tension throughout the life of the belt. No periodic adjustment is required. Inspect the belt annually for proper tracking and tension. A properly tensioned belt will turn the wheel immediately, with no visible slippage, when power is applied.

CAUTION

Sharp Edges!

Failure to follow instructions below could result in minor to moderate injury.

The service procedure described in this document involves working around sharp edges. To avoid being cut, technicians **MUST** put on all necessary Personal Protective Equipment (PPE), including gloves and arm guards.

Bearing/Drive Belt Replacement for Sizes 10- 50

Bearing removal on the pulley side of the wheel is required to remove and replace the drive belt for unit sizes 10 to 50. Bearing removal is discussed first in this procedure.

1. Disconnect all electrical power.
2. Obtain access to the pulley side bearing access plate.
3. Remove the two bearing access plate retaining screws and the access plate.
4. Using a hexagonal wrench, loosen the set screw in the bearing locking collar.

5. Using a light hammer and a drift placed in the drift pin hole in the collar, tap the collar in the opposite direction of wheel rotation to unlock it.
6. Remove the collar.
7. Using a socket wrench with an extension, remove the two nuts that secure the bearing housing to the bearing support beam.
8. Slide the bearing from the shaft. Note that slight hand pressure against the wheel rim will lift the weight of wheel from the inner race of the bearing to assist in its removal and installation. The use of a bearing puller may be required.
9. Using a wrench, remove the diameter seal retaining screws or hub seal retaining screws and remove the diameter seals or hub seals from the bearing beam. See [Figure 192, p. 159](#) for an exploded view of the shaft, bearings, belt, etc.

Figure 192. For belt replacement, loop the trailing end of the belt over the shaft (shown with diameter seals removed).

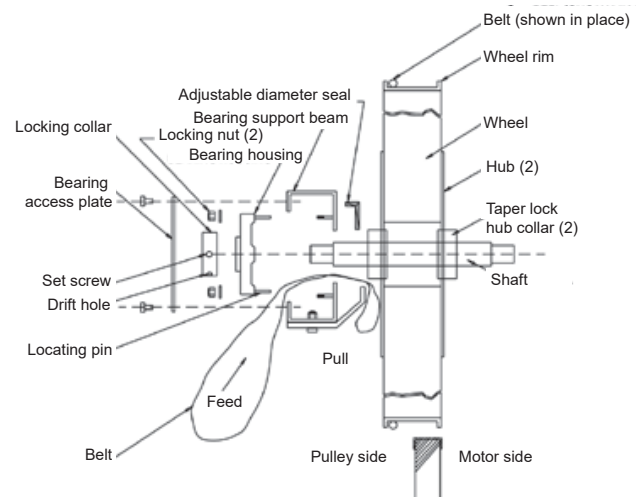

10. Remove the old belt. Form a small loop of belt and pass it through the hole in the bearing support beam.
11. Grasp the belt at the wheel hub and pull the entire belt down.
12. Loop the trailing end of the belt over the shaft. Shows the belt partially through the opening.
13. Re-install the bearing onto the wheel shaft, being careful to engage the two locating pins into the holes in the bearing support beam.
14. Secure the bearing with two self-locking nuts.
15. Install the belt around the wheel and pulley according to the instructions provided with the belt.
16. Re-install the diameter seals or hub seal and tighten the retaining screws.
17. Adjust the seals according to the procedure in ["Energy Wheel Seal Adjustment," p. 160](#).

18. Rotate the wheel in a clockwise direction to confirm that it rotates freely with slight drag on seals.
19. Re-install the bearing locking collar.
20. Rotate the collar by hand in the direction of wheel rotation.
21. Lock the collar in position by tapping the drift pin hole with a hammer and drift.
22. Secure the collar in position by tightening the set screw.
23. Re-install the bearing access cover.
24. Apply power to the wheel and ensure that the wheel rotates freely without interference.

For sizes 3 to 8

Bearing removal is not required on slide-out cassettes, unit sizes 3 to 8. These belts may be replaced by temporarily dismounting and rotating the pulley side bearing beam to allow the new belt to be installed on the wheel rim.

1. Disconnect electrical power to the energy wheel.
2. Remove the access panel.
3. Disconnect all controls wiring.
4. Slide the entire cassette assembly out of the module.
5. Loosen the two set screws on the wheel support beam bearings, one on each side of wheel.
6. Remove the belt from the pulley and temporarily position it around the rim.
7. Remove the pulley side wheel support beam with the bearing.
8. Pull the wheel with the shaft straight out of the motor side wheel support beam and bearing (see [Figure 193, p. 160](#)). Do not disassemble the bearings from the beam unless they require replacement. Handle the wheel with care to avoid distorting the wheel.

Figure 193. Unit sizes 3 to 8 bearing assembly

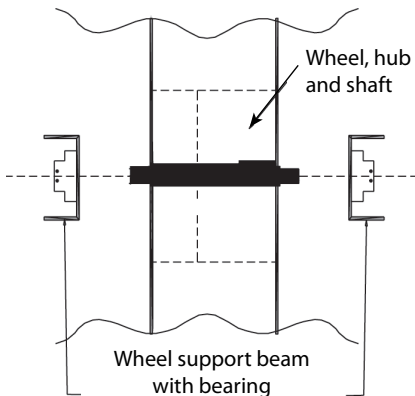

9. Reverse the removal procedure to re-install. Check to ensure that the wheel remains in the center of the seal plate opening.

Energy Wheel Seal Adjustment

1. Back seals away from the wheel surface as follows (and as shown in [Figure 194, p. 160](#)):

Figure 194. Energy wheel seal adjustment

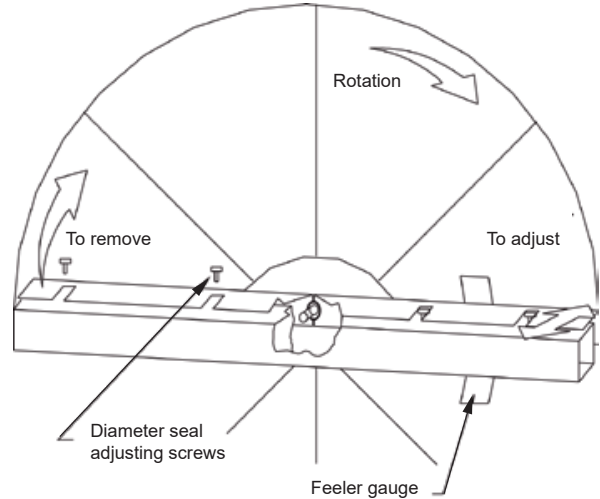

- a. Loosen the diameter seal adjustment screws.
- b. Back the seals away from the wheel surface.
2. Rotate the wheel clockwise until two opposing spokes are hidden behind the bearing support beam.
3. Using a folded piece of paper as a feeler gauge, position the paper between the wheel surface and the diameter seals.
4. Adjust the seals toward the wheel surface until slight friction on the paper feeler gauge is felt when the gauge is moved along the length of the spoke.
5. Check the adjustment through a full rotation of the wheel.
6. Retighten the adjusting screws and recheck the clearance with the paper feeler gauge.

Energy Wheel Drive Motor and Pulley Replacement

⚠ WARNING

Hazardous Voltage!

Failure to disconnect power before servicing could result in death or serious injury.

Disconnect all electric power, including remote disconnects before servicing. Follow proper lockout/tagout procedures to ensure the power can not be inadvertently energized. Verify that no power is present with a voltmeter.

1. Disconnect all electrical power.
2. Remove the belt from the pulley and temporarily position it around the wheel rim.

3. Measure and record the distance from the inner edge of the pulley to the mounting wall.
4. Loosen the set screw in the wheel drive pulley using an Allen wrench and remove the pulley from the motor drive shaft.
5. While supporting the weight of the drive motor in one hand, loosen and remove the four mounting bolts.
6. Install a replacement motor with the hardware kit supplied.
7. Install the pulley and adjust it to the distance recorded in the previous step.
8. Tighten the set screw to the drive shaft.
9. Stretch the belt over the pulley and engage it in the groove.

Fans

⚠ WARNING

Rotating Components!

Failure to secure rotor or disconnect power before servicing could result in rotating components cutting and slashing technician which could result in death or serious injury.

The following procedure involves working with rotating components.

- Disconnect all electric power, including remote disconnects before servicing.
- Follow proper lockout/tagout procedures to ensure the power cannot be inadvertently energized.
- Secure rotor to ensure rotor cannot freewheel.

Bearing Set Screw Alignment

Align bearing set screws for belt-drive fans as illustrated in [Figure 195, p. 161](#). See for set screw torque measurements.

Figure 195. Bearing set screw alignment

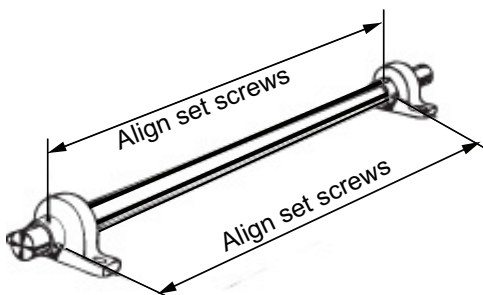

Torque Requirements

See [Table 48, p. 161](#) for minimum torque of motor mounting and bearings bolts.

Table 48. Minimum hex head bolt torque in lb.-ft. (Grade 5 bolts)

Size (inches)	Thread Designation	Minimum Torque
1/4 to 20	UNC	6
1/4 to 28	UNF	7
65/16 to 18	UNC	14
5/16 to 24	UNF	16
3/8 to 16	UNC	24
3/8 to 24	UNF	28
7/16 to 14	UNC	42
7/16 to 20	UNF	45
1/2 to 13	UNC	69
1/2 to 20	UNF	83
9/16 to 12	UNC	99
9/16 to 18	UNF	118
5/8 to 11	UNC	150
5/8 to 18	UNF	176
3/4 to 10	UNC	254
3/4 to 16	UNF	301
7/8 to 9	UNC	358
7/8 to 14	UNF	422
1 to 8	UNC	500
1 to 14	UNF	602

Note: Soft metric conversions are not acceptable for screw and hex sizes.

Fan Bearing Lubrication

NOTICE

Bearing Failure!

Do not mix greases with different bases within the bearing as it could result in premature bearing failure.

For belt-drive fans, the grease used in electric motor bearings is usually not compatible with the grease used in fan bearings. Never mix the two grease types! See [Table 49, p. 162](#) for compatible greases and [Table 50, p. 162](#) for maximum grease capacity.

Note: Lubricate the motor bearing according to the motor manufacturer's recommendations and use the manufacturer-recommended grease. See "Motor Bearing Lubrication," p. 162.

Routine Maintenance

Table 49. Compatible greases

Type
Texaco Multi Fak 2
Shell Alvania 2
Mobil 532
Chevron Dura-Lith 2
Exxon Beacon
Keystone 84H

Table 50. Fan bearing maximum grease capacity

Shaft size (inches)	Capacity (fluid ounce)
1/2 to 3/4	1/7
7/8 to 1 3/16	3/8
1 1/4 to 1 1/2	5/8
1 11/16 to 1 15/16	7/8
2 to 2 7/16	1 1/4
2 1/2 to 2 15/16	2

- Fan bearings without lubrication lines are sealed bearings. Re-lubrication is not required.
- Fan bearings equipped with lubrication lines should be lubricated with a lithium-based grease that conforms to NLGI No. 2 for consistency.

Motor Bearing Lubrication

Obtain an operation and maintenance manual from the motor manufacturer for the specific motor installed. The motor manufacturer's recommendations take precedence for all matters related to the start-up and routine maintenance of the motor.

Motor grease fittings have been removed from factory-installed motors in compliance with UL regulations. Motor bearings require periodic maintenance throughout their life. Many different styles of motors come as standard selections, so please obtain the motor IOM and use the manufacturer-recommended grease.

Fan Motor Inspection

Inspect fan motors periodically for excessive vibration or temperature. Operating conditions will vary the frequency of inspection and lubrication. Motor lubrication instructions are on the motor tag or nameplate. If for some reason these instructions are not available, contact the motor manufacturer. Some motor manufacturers may not provide oil tubes on motors with permanently sealed bearings.

Fan Block-off Plate

Mount one plate on a fan that is out of operation. For direct-drive plenum fans, the plate will be mounted directly to the

fan wall. For motorized impeller fans, the plate will be mounted to the support stiffeners attached to the fan wall.

Figure 196. DDP fan block-off plate

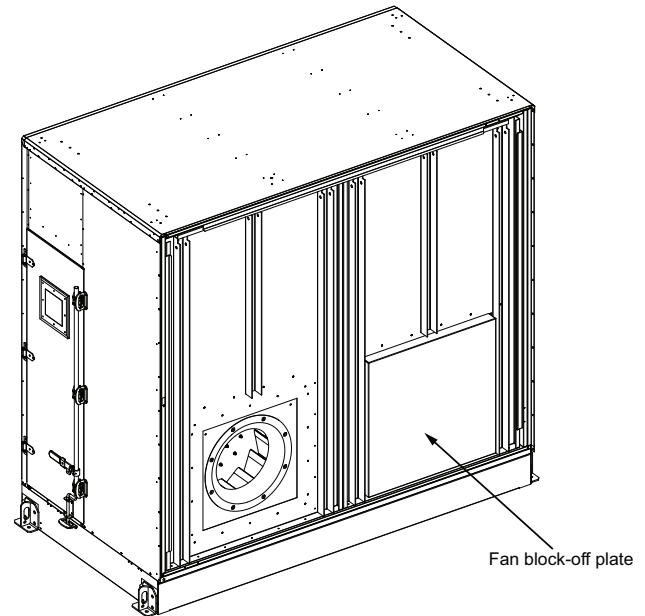
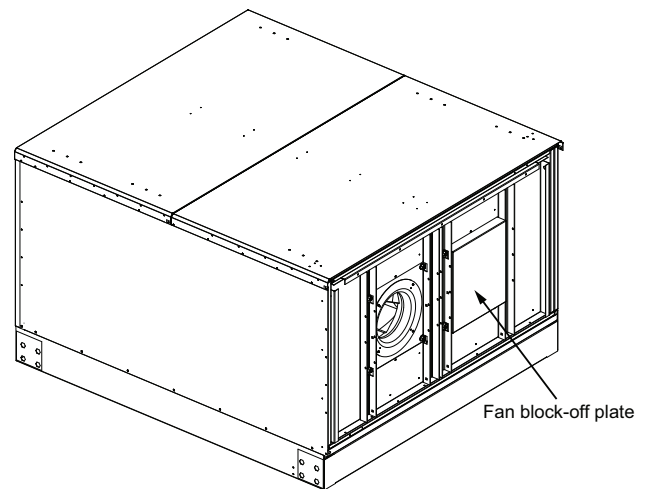

Figure 197. MI fan block-off plate



Filters

⚠ WARNING

Rotating Components!

Failure to secure rotor or disconnect power before servicing could result in rotating components cutting and slashing technician which could result in death or serious injury.

The following procedure involves working with rotating components.

- **Disconnect all electric power, including remote disconnects before servicing.**
- **Follow proper lockout/tagout procedures to ensure the power cannot be inadvertently energized.**
- **Secure rotor to ensure rotor cannot freewheel.**

Throwaway Filters

To replace throwaway filters, install new filters with the directional arrows pointing in the direction of airflow.

Note: Bag and cartridge filters must have an airtight seal to prevent air bypass. If using filters not supplied by Trane, apply foam gasketing to the vertical edges of the filter.

Permanent Filters

To clean permanent filters:

1. Disconnect all electrical power to the unit.
2. Wash the filter under a stream of water to remove dirt and lint.
3. Remove oil from the filter with a wash of mild alkali solution.
4. Rinse the filter in clean, hot water and allow to dry.
5. Coat both sides of the filter by immersing or spraying it with Air Maze Filter Kote W or an equivalent.
6. Allow to drain and dry for about 12 hours.
7. Reinstall the filter.

Note: It may be preferable to keep extra, clean filters to replace the dirty filters to minimize unit downtime for filter maintenance.

Moisture Eliminator

The moisture eliminators in the outside air intake hood must be cleaned periodically. Remove the eliminators by detaching the access panels to either side of the hood. Thoroughly clean the eliminator by using a high pressure sprayer. The airflow direction is imprinted on the frame of the eliminator. Direct the spray into the air leaving side of the eliminator for effective cleaning. Reassemble the eliminator into the hood, ensuring the eliminators are

oriented in the proper airflow direction and access covers are securely attached.

Cartridge or Bag Filters

To replace cartridge or bag filters:

1. Disconnect all electrical power to the unit.
2. Remove the dirty filters from their installed position.
3. Keeping the new bag filters folded, slide each filter into the filter rack, pushing them tightly against the unit.
Note: The pleats should be in the vertical position.
4. If using the optional pre-filters, replace them on the appropriate filter rack.
5. Close and secure the access door.

Ultraviolet (UV) Light Maintenance

The intensity of the ultraviolet energy emitted from the ultraviolet bulbs is dependent on the cleanliness and age of the bulb. The surface of the bulb should be kept as clean as possible for optimum intensity. Depending on the filtration level of the HVAC system and the general hygiene of the building, periodic cleaning may be necessary. Before attempting any maintenance procedures, always follow all warnings and cautions as detailed in this maintenance section.

⚠ WARNING

Hazardous Voltage and Exposure to Ultraviolet Radiation!

This product contains components that emit high-intensity ultraviolet (UV-C) radiation which can be harmful to unprotected eyes and skin, and cause serious damage to the equipment.

Failure to disconnect power before servicing could result in burns or electrocution which could result in death or serious injury.

Disconnect all electrical power, including remote disconnects, and make sure the UV lights are off before servicing. Follow proper lockout/tagout procedures to ensure the power cannot be inadvertently energized.

Trane does not recommend field installation of ultraviolet lights in its equipment for the intended purpose of improving indoor air quality. Trane accepts no responsibility for the performance or operation of our equipment in which ultraviolet devices were installed outside of the Trane factory or its approved suppliers.

⚠ WARNING

Hazardous Mercury Vapors!

Failure to follow instructions could result in death or serious injury. Mercury vapors are toxic and inhaling them could result in poisoning and suffocation.

If large numbers of UV bulbs are broken, an appropriate respirator, as described in OSHA 1910.134, **MUST** be worn to prevent inhalation of mercury vapors.

Cleaning the Bulbs

Note: If bulbs are found to be broken, see the proper warning and cautions below regarding broken bulbs and hazardous vapors.

1. Disconnect all electrical power to the unit and the ultraviolet bulbs.
2. Wearing soft cloth gloves and safety glasses, loosen the compression nut on each end of the bulb, use two hands and firmly grasp the bulb at each end.
3. Rotate the bulb 90 degrees in either direction and move bulb away from the fixture and out of unit.
4. Wipe down each bulb with a clean cloth and alcohol. Avoid touching the bulb with bare hands as skin oils can accelerate future glass soiling and degrade the bulb performance.
5. Wearing soft cloth gloves and safety glasses, install lamp by grasping each non-glass end with the thumb and index fingers. Carefully push lamp ends into previously mounted lamp clamps and tighten compression nuts.
6. Attach the loom to the lamp by firmly pushing the four-port connector onto the four pins on the lamp end.

Note: Connection must be snug to avoid potential arcing.

Replacing the Bulbs

Ultraviolet bulbs should be replaced annually if operated continuously or after 9,000 hours of use if operated intermittently. Replacement bulbs must be the specific size and wattage as originally supplied from the factory. Replacement UV bulb part ID assistance available on the HUB - DOC-136773.

Note: Although the lights may continue to generate a characteristic blue glow beyond 9,000 operating hours, the ultraviolet radiation emitted by the bulbs degrades over time and will no longer provide the intended benefit.

1. Disconnect power to the HVAC unit and the ultraviolet bulbs. See WARNING Hazardous Mercury Vapors.
2. Before installation, lamps should be cleaned using 99 percent isopropyl alcohol and a lint free cloth.

Note: If Teflon coated EncapsuLamp™ is used, it is not necessary to clean the surface.

Figure 198. UV lamp



3. Wearing soft cloth gloves and safety glasses, install lamp by grasping each non-glass end with the thumb and index fingers. Carefully push lamp ends into previously mounted lamp clamps and tighten compression nuts.

Figure 199. Plug pins into socket, then tighten compression nut



4. Attach the loom to the lamp by firmly pushing the four-port connector onto the four pins on the lamp end.
- Note:** Connection must be snug to avoid potential arcing.
5. If broken bulbs are found or if you are required to dispose of used bulbs, the proper warning and cautions must be followed.

⚠ CAUTION**Broken Glass!**

Failure to handle bulbs properly could result in minor to moderate injury.

Bulbs are fragile and can be easily broken. To avoid getting cut, always use cloth gloves and eye protection when handling, cleaning or replacing these bulbs. Bulbs may break if dropped or handled improperly. Refer to the MSDS sheet from the bulb manufacturer for additional safety information.

Disposal of Bulbs

UV bulbs, like fluorescent bulbs, contain mercury, which is a regulated hazardous waste. The disposal requirements for hazardous wastes are determined by local, state and federal guidelines. Check all regulations before disposing of bulbs to assure you have met all requirements.

Refer to the MSDS sheet from the bulb manufacturer for additional disposal, handling and safety information.

After replacing bulbs, close and latch all unit panels and reenergize power to the lights.



Troubleshooting

This section is intended to be used as a diagnostic aid only. For detailed repair procedures, contact your local Trane service representative.

⚠ WARNING
<p>Hazardous Service Procedures!</p> <p>Failure to follow all precautions in this manual and on the tags, stickers, and labels could result in death or serious injury.</p> <p>Technicians, in order to protect themselves from potential electrical, mechanical, and chemical hazards, MUST follow precautions in this manual and on the tags, stickers, and labels, as well as the following instructions: Unless specified otherwise, disconnect all electrical power including remote disconnect and discharge all energy storing devices such as capacitors before servicing. Follow proper lockout/tagout procedures to ensure the power can not be inadvertently energized. When necessary to work with live electrical components, have a qualified licensed electrician or other individual who has been trained in handling live electrical components perform these tasks.</p>

Table 51. Air handler troubleshooting recommendations

Symptom	Probable Cause	Recommended Action
Bearing is excessively hot	First start after relubrication (Grease distribution)	Allow machine to cool down and restart.
	Over-lubrication	Clean surface of grease and purge.
	No lubricant	Apply lubricant. Check bearings for damage.
	Misaligned bearing	Correct alignment. Check shaft level.
Motor fails to start	Blown fuse or open circuit breaker	Replace fuse or reset circuit breaker.
	Overload trip	Check and reset overload.
	Improper wiring or connections	Check wiring with diagram supplied on unit.
	Improper current supply	Compare actual supply power with motor nameplate recommendations. Contact power company for adjustments.
	Mechanical failure	Check that motor and drive rotate freely. Check bearing lubricant.
Motor stalls	Open phase	Check line for an open phase.
	Overloaded motor	Reduce load or replace with larger motor.
	Low line voltage	Check across AC line. Correct voltage if possible.
Excessive vibration	Poor alignment	Align bearing set screws. Loosen and retighten bearing set screws.
	Shipping spacers not removed	Remove shipping spacers and/or bolts (see "Fan Isolation," p. 82).
Motor runs and then dies down	Partial loss of line voltage	Check for loose connections. Determine adequacy of main power supply.
	Starter shorts when motor warms up	Replace starter.

Table 51. Air handler troubleshooting recommendations (continued)

Symptom	Probable Cause	Recommended Action
Motor does not come up to speed	Low voltage at motor terminals	Check across AC line and correct voltage loss if possible.
	Line wiring to motor too small	Replace with larger sized wiring.
Motor overheats	Overloaded motor	Reduce load or replace with a larger motor.
	Motor fan is clogged with dirt preventing proper ventilation	Remove fan cover, clean fan and replace cover.
Excessive motor noise	Motor mounting bolts loose	Tighten motor mounting bolts.
	Rigid coupling connections	Replace with flexible connections.
	Worn motor bearings	Replace bearings and seals.
	Fan rubbing on fan cover	Remove interference in motor fan housing.
Rapid motor bearing wear	Excessive overhung load due to over-tensioned drive	Check belt tension and overhung load.
	Excessive overhung load due to a small diameter motor sheave	Replace sheave with larger one.
Bearing noise	Failed bearing	Replace bearing.
	Inadequate lubrication	Replace bearing.
Low water coil capacity ^(a)	Incorrect airflow	Check fan operating condition.
	Incorrect water flow	Inspect the water pumps and valves for proper operation and check the lines for obstructions.
	Incorrect water temperature	Adjust the chiller or boiler to provide the proper water temperature.
	Coil is piped incorrectly	Verify coil piping (see "Piping and Connections," p. 106).
	Dirty fin surface	Clean the fin surface (see "Coils," p. 147).
	Incorrect glycol mixture	Verify glycol mixture and adjust if necessary.
Drain pan is overflowing	Plugged Drain Line	Clean drain line
	Unit not level	Level unit
	Improper trap design	Design trap per unit installation instructions
Standing water in drain pan	Improper trap design	Design trap per unit installation instructions
	Unit not level	Level unit
	Plugged drain line	Clean drain line
Wet interior	Coil face velocity too high	Reduce fan speed
	Improper trap design	Design trap per unit installation instructions
	Drain pan leaks/overflows	Repair leaks
	Condensation on surfaces	Insulate surfaces
Excess dirt in unit	Missing filters	Replace filters
	Filter bypass	Reduce filter bypass by ensuring all blockoffs are in place.
Microbial growth (mold) inside air handler	Standing water in drain pan	See Standing water in drain pan above

Troubleshooting

Table 51. Air handler troubleshooting recommendations (continued)

Symptom	Probable Cause	Recommended Action
Energy wheel or CDQ wheel will not rotate	Motor is not running	The fuse or circuit breaker may be blown or open. Check the breaker/fuse box and replace.
		There may be a loss of incoming power. Attempt to trace the power loss back to its source and correct.
		The motor may have failed. Check for power at the motor terminals. If present, disconnect the belt from the motor pulley and see if the motor runs without a load. If it still doesn't run, replace the motor.
		The motor may have failed because it is connected to a variable frequency drive. Disconnect the VFD and run the motor on 60 Hz power only.
	Excessive friction at the seals	Re-adjust the diameter seals. See "Energy Wheel Seal Adjustment," p. 160 or "CDQ Seal Adjustment," p. 155.
	Energy wheel frame or spokes are bent or warped	Inspect the wheel, locate the bent section, and straighten the section or replace the frame.
	During winter operation, excessive frost/ice forms in the heat transfer media	Disconnect power to the wheel motor, adjust outside air dampers shut and let the wheel thaw. After the initial section thaws, rotate the wheel 90 degrees by hand until the "new" section rotates into the warm exhaust air stream. Continue this procedure until the wheel is completely thawed.
Loss of energy wheel capacity	Drive belt is broken	Inspect visually. Replace the drive belt.
	Wheel main shaft bearing is seized	Replace the seized bearing.
	Wheel is not rotating	See above
	Wheel is rotating too slowly	Belt is stretched, slipping. Replace the belt.
		Ice forms on the wheel; thaw per above.

^(a) For coil replacement instructions, contact Technical Service.



Notes

Trane - by Trane Technologies (NYSE: TT), a global innovator - creates comfortable, energy efficient indoor environments for commercial and residential applications. For more information, please visit trane.com or tranetechnologies.com.

Trane has a policy of continuous product and product data improvements and reserves the right to change design and specifications without notice. We are committed to using environmentally conscious print practices.

CLCH-SVX016D-EN 01 Jul 2026
Supersedes CLCH-SVX016C-EN (December 2025)

©2026 Trane