



Installation, Operation, and Maintenance **Performance Climate Changer™** **Air Handlers for Data Center Applications**

Model: PSCA

⚠ SAFETY WARNING

Only qualified personnel should install and service the equipment. The installation, starting up, and servicing of heating, ventilating, and air-conditioning equipment can be hazardous and requires specific knowledge and training. Improperly installed, adjusted or altered equipment by an unqualified person could result in death or serious injury. When working on the equipment, observe all precautions in the literature and on the tags, stickers, and labels that are attached to the equipment.

February 2025

CLCH-SVX015B-EN

TRANE
TECHNOLOGIES™



Introduction

Read this manual thoroughly before operating or servicing this unit.

Warnings, Cautions, and Notices

Safety advisories appear throughout this manual as required. Your personal safety and the proper operation of this machine depend upon the strict observance of these precautions.

The three types of advisories are defined as follows:



Indicates a potentially hazardous situation which, if not avoided, could result in death or serious injury.



Indicates a potentially hazardous situation which, if not avoided, could result in minor or moderate injury. It could also be used to alert against unsafe practices.



Indicates a situation that could result in equipment or property-damage only accidents.

Important Environmental Concerns

Scientific research has shown that certain man-made chemicals can affect the earth's naturally occurring stratospheric ozone layer when released to the atmosphere. In particular, several of the identified chemicals that may affect the ozone layer are refrigerants that contain Chlorine, Fluorine and Carbon (CFCs) and those containing Hydrogen, Chlorine, Fluorine and Carbon (HCFCs). Not all refrigerants containing these compounds have the same potential impact to the environment. Trane advocates the responsible handling of all refrigerants.

Important Responsible Refrigerant Practices

Trane believes that responsible refrigerant practices are important to the environment, our customers, and the air conditioning industry. All technicians who handle refrigerants must be certified according to local rules. For the USA, the Federal Clean Air Act (Section 608) sets forth the requirements for handling, reclaiming, recovering and recycling of certain refrigerants and the equipment that is used in these service procedures. In addition, some states or municipalities may have additional requirements that must also be adhered to for responsible management of refrigerants. Know the applicable laws and follow them.

⚠ WARNING

Proper Field Wiring and Grounding Required!

Failure to follow code could result in death or serious injury.

All field wiring **MUST** be performed by qualified personnel. Improperly installed and grounded field wiring poses **FIRE** and **ELECTROCUTION** hazards. To avoid these hazards, you **MUST** follow requirements for field wiring installation and grounding as described in **NEC** and your local/state/national electrical codes.

⚠ WARNING

Personal Protective Equipment (PPE) Required!

Failure to wear proper PPE for the job being undertaken could result in death or serious injury.

Technicians, in order to protect themselves from potential electrical, mechanical, and chemical hazards, **MUST** follow precautions in this manual and on the tags, stickers, and labels, as well as the instructions below:

- **Before installing/servicing this unit, technicians MUST put on all PPE required for the work being undertaken (Examples; cut resistant gloves/sleeves, butyl gloves, safety glasses, hard hat/bump cap, fall protection, electrical PPE and arc flash clothing). ALWAYS refer to appropriate Safety Data Sheets (SDS) and OSHA guidelines for proper PPE.**
- **When working with or around hazardous chemicals, ALWAYS refer to the appropriate SDS and OSHA/GHS (Global Harmonized System of Classification and Labelling of Chemicals) guidelines for information on allowable personal exposure levels, proper respiratory protection and handling instructions.**
- **If there is a risk of energized electrical contact, arc, or flash, technicians MUST put on all PPE in accordance with OSHA, NFPA 70E, or other country-specific requirements for arc flash protection, PRIOR to servicing the unit. NEVER PERFORM ANY SWITCHING, DISCONNECTING, OR VOLTAGE TESTING WITHOUT PROPER ELECTRICAL PPE AND ARC FLASH CLOTHING. ENSURE ELECTRICAL METERS AND EQUIPMENT ARE PROPERLY RATED FOR INTENDED VOLTAGE.**

⚠ WARNING**Follow EHS Policies!**

Failure to follow instructions below could result in death or serious injury.

- All Trane personnel must follow the company's Environmental, Health and Safety (EHS) policies when performing work such as hot work, electrical, fall protection, lockout/tagout, refrigerant handling, etc. Where local regulations are more stringent than these policies, those regulations supersede these policies.
- Non-Trane personnel should always follow local regulations.

Additional Environmental Information

Air handler foamed panels rely on a foam system that utilizes water and R-1233zd as blowing agents.

Copyright

This document and the information in it are the property of Trane, and may not be used or reproduced in whole or in part without written permission. Trane reserves the right to revise this publication at any time, and to make changes to its content without obligation to notify any person of such revision or change.

Trademarks

All trademarks referenced in this document are the trademarks of their respective owners.

Factory Training

Factory training is available through Trane University™ to help you learn more about the operation and maintenance of your equipment. To learn about available training opportunities contact Trane University™.

Online: www.trane.com/traneuniversity

Email: traneuniversity@trane.com



Table of Contents

General Information	6	Piping Package	19
Overview of Manual	6	Water Coil Piping	20
Nameplate	6	Fan Coil Wall Package Installation	20
Operating Environment	6	Piping Installation	20
Unit Description	6	Actuator Installation	21
Components	6	Actuator Wiring	22
Factory-Mounted Controls	6	Installation – Electrical	24
Pre-Packaged Configurations for		Typical Wiring Schematics	25
Controls	7	Controls Interface	27
Wiring	7	Connecting the Operator Display	27
Pre-Installation	8	Calibrating the Operator Display	27
Receiving and Handling	8	Adjusting Brightness and Contrast	27
Inspection	8	External Communications Port	27
Packaging/Shipping	8	Start-Up	28
Identification	8	Pre-Startup Checklist	28
Handling	8	General Checks	28
Receiving Checklist	8	Fan-Related Checks	28
Jobsite Storage	8	Coil-Related Checks	28
Outdoor Storage	8	Fan Inlet Airflow Measuring System	28
Long-Term Storage	9	Wiring	29
Site Preparation	9	Transmitter Sizing	29
Dimensions and Weights	10	Transmitter Calibration	29
Service Clearance Recommendations	10	Maintenance	29
Installation – Mechanical	11	Constant K Factor	29
Lifting and Rigging	11	External Insulating Requirements	30
General Lifting Considerations	11	Routine Maintenance	31
Fork lifting Considerations	11	Maintenance Checklist	31
Unit Placement and Assembly	12	Cleaning the Unit	31
Removing the Shipping Skid	12	Cleaning Non-Porous Surfaces	31
Seismic Application Requirements	14	Cleaning Porous Surfaces	32
Single Level Design	14	Coils	32
Stacked Design	15	Water Coils	32
Anchoring	15	Coil Winterization	33
Component Installation	17	Moisture Purge Cycle	33
Filters	17	Drain Pans	33
Filter Installation	17	Fans	34
Piping and Connections	18	Inspecting and Cleaning Fans	34
General Recommendations	18	Fan Motor Inspection	34
Drain Pan Trapping	18	Filters	34
		Throwaway Filters	34

Troubleshooting 35



General Information

Overview of Manual

Use this manual to install, startup, operate, and maintain the Performance Climate Changer™ air handler model PSCA. Carefully review the procedures discussed in this manual to minimize installation and startup difficulties.

Nameplate

Each Performance air handler section includes one or more nameplate/label, which identifies the type of section

Figure 1. Performance PSCA air handler section nameplate

Performance Climate Changer™ Air Handler

ORDER NO. / BL	Y0H225A / A
SERIAL NO.	K16M92993
UNIT MODEL NO.	PSCA072UAAA
TAG ID	PSCA-Unit 20
BUILD SECTION	1 OF 8

RETURN FAN SECTION

MOTOR VOLTAGE	460/603
MOTOR HORSEPOWER	10
MAXIMUM INVERTER FREQUENCY (HZ)	86.0

THIS UNIT CONTAINS ECONOMIZER THAT MEETS OR EXCEEDS ALL MANDATORY REQUIREMENTS PRESCRIBED BY TITLE 24, INCLUDING BUT NOT LIMITED TO 5 YR PARTS ONLY WARRANTY, SUCCESSFULLY TESTED TO 60,000 ACTUATION LESS THAN 10 CFMSQ.FT. OF DAMPER LEAKAGE AT 1" WG PER AMCA 500L. NOTE: AN EXTERNAL OVERLOAD DEVICE IN ACCORDANCE WITH THE NATIONAL ELECTRICAL CODE (OR CEC) IS REQUIRED WHEN NOT PROVIDED BY TRANE. SUPPLY AIR TEMPERATURE LIMITATIONS: 104 F MAX IN DRAW-THRU ARRANGEMENTS; 200 F MAX IN BLOW-THRU ARRANGEMENTS. FIELD CONDUCTORS SHALL HAVE INSULATION RATING NOT LESS THAN 600V.

Manufactured under one or more of the following patent numbers:
6237354, 6972795, 7017355, 7150314, 7178355, 7340806, 7389846, 7526603, 7685634, 8231334, 8911206

Trane www.trane.com Made in USA

and functional components, customer tagging information, the unit serial number, the unit order number, the build-section position for installation, and the unit model number.

Note: The unit serial number and order number is required when ordering parts or requesting service for a Trane air handler.

Operating Environment

The Performance Climate Changer™ air handler is a central station air handler for indoor and outdoor applications. When considering the placement of the air handler, it is important to consider the operating environment. The acceptable ambient temperature range for unit operation is -40°F to 140°F (-40°C to 60°C).

For heating applications, a special motor may be required to withstand the higher temperatures. Motors with Class B insulation are acceptable for ambient temperatures up to 104°F, while motors with Class F insulation can withstand ambient temperatures to 140°F (60° C).

Note: Units with UL approval have a maximum ambient temperature requirement of 104°F. The customer should provide adequate freeze protection for the coils. See “Coils,” p. 32 for more information.

Unit Description

The Performance Climate Changer air handler is designed for a variety of controlled-air applications. The basic unit consists of a fan, heating and/or cooling coils, filters, and optional dampers.

Components

Trane air handlers ship as complete assemblies or in subassemblies if shipping splits are required. Some assembly is required when the unit ships in sub-assemblies.

For more information, contact your local Trane sales office.

Factory-Mounted Controls

Trane air handlers are available with a wide selection of factory-mounted controls, end devices, including Symbio™ controls, and variable frequency drives (VFD).

Most control components are mounted inside the unit. Depending on the system configuration, this may include dirty filter switches, averaging temperature sensors, and low limit switches. VFDs, new end devices, controllers, control transformers, static pressure transducers, DC power supplies, and customer interface relays will be in enclosures mounted on the inside of the unit.

Items that cannot be factory-mounted, such as space temperature sensors, outside air temperature sensors, and humidity sensors, will ship inside the control enclosures, or packaged and shipped inside the fan section.

Note: All control valves ship directly to the ship-to address from the vendor unless another address is given on the Trane sales order.

Pre-Packaged Configurations for Controls

If the air handler has been selected using a Trane pre-packaged solutions option for controls, there are a number of resources available to aid in commissioning and start-up of the unit. These resources include commissioning sheets, graphics, and technical application notes. The technical application notes include the control sequencing, Trane Graphic Programming (TGP), and Rover set-up files for the specific unit selected. These resources are available through your local Trane sales office.

For more information on controls, refer to the following manuals:

- Programmable Symbio™ 500 controllers
 - *Symbio™ 500 Programmable Controller Installation, Operation, and Maintenance* (BAS-SVX090*-EN)
 - *Installing the Tracer TD7 Display* (X39641191-01*)
- TR150 Drives
 - *TR150 and TR170 Design Guide* (BAS-SVX59*-EN)

- *TR150 and TR170 Programming Guide* (BAS-SVP16*-EN)

Wiring

⚠ WARNING

Proper Field Wiring and Grounding Required!

Failure to follow code could result in death or serious injury.

All field wiring MUST be performed by qualified personnel. Improperly installed and grounded field wiring poses FIRE and ELECTROCUTION hazards. To avoid these hazards, you MUST follow requirements for field wiring installation and grounding as described in NEC and your local/state/national electrical codes.

⚠ WARNING

Electrical Shock Hazard!

Failure to follow instructions below could result in death or serious injury.

Properly connect the system's oversized protective earthing (grounding) terminal(s).

Before installation, consider overall unit serviceability and accessibility before mounting, running wires (power), making penetrations, or mounting any components to the cabinet.

Wiring to the air handler must be provided by the installer and must comply with all national and local codes. The fan motor nameplate includes a wiring diagram. If there are any questions concerning the wiring of the motor, write down the information on the motor nameplate and contact your local Trane sales office.



Pre-Installation

Receiving and Handling

Inspection

Upon delivery, thoroughly inspect all components for any shipping damage that may have occurred, and confirm that the shipment is complete. See “Receiving Checklist,” p. 8 section for detailed instructions.

Note: *Delivery cannot be refused. All units are shipped F.O.B. factory. Trane is not responsible for shipping damage.*

Packaging/Shipping

Performance air handlers ship as a complete unit or in individual sections to be field assembled. Indoor air handler sections are stretch-wrapped or shrink-wrapped before shipping. All factory shipping protection should be removed upon delivery. This wrapping is for transit protection only.

Indoor Performance air handlers ship in subassemblies if the total length of the units exceeds 98 inches or if the total weight exceeds factory limits. Refer to the equipment Submittal for unit-specific shipping split sizes and weights.

Items that cannot be factory-mounted, such as space temperature sensors, outside air temperature sensors, and humidity sensors, will ship inside the control enclosures, or packaged and shipped inside the fan.

Note: *All control valves ship directly to the ship-to address from the vendor unless another address is given on the Trane sales order.*

Identification

Each air handler section includes a nameplate identifying the section type and functional components, customer tagging information, unit serial number, unit order number, the build-section position for installation, and the unit model number. See “Nameplate,” p. 6.

Handling

Air handlers have an integral base frame designed with the necessary number of lift points for safe installation. See “Lifting and Rigging,” p. 11.

Receiving Checklist

Complete the following checklist immediately after receiving shipment to detect possible shipping damage.

- Verify the shipment is complete. Small components may ship inside the unit or ship separately. Check the parts list to confirm all materials are present. If any component is missing, contact your local Trane sales office.
- Check all units, components, connections, and piping. Check fan wheel for free rotation by spinning manually. Check all doors, latches and hinges. Inspect interior of

each unit or section. Inspect coils for damage to fin surface and coil connections. Check for rattles, bent corners, or other visible indications of shipping damage. Tighten loose connections.

- If a unit is damaged, make specific notations concerning the damage on the freight bill. Do not refuse delivery.
- Notify the carrier’s terminal of the damage immediately by phone and mail. Request an immediate joint inspection of the damage by the carrier and consignee.
- Notify your Trane sales representative of the damage and arrange for repair. Do not attempt to repair the unit without consulting the Trane representative.
- Inspect the unit for concealed damage as soon as possible after delivery. Report concealed damage to the freight line. It is the receiver’s responsibility to provide reasonable evidence that concealed damage did not occur after delivery. Take photos of damaged material if possible.

Note: *Concealed damage must be reported to the Freight Carrier in writing within 5 business days of receipt.*

Jobsite Storage

Indoor air handlers and field-installed accessories must be protected from the elements. A controlled indoor environment is recommended for proper storage.

Note: *All factory shipping protection should be removed. This wrapping is for transit protection only.*

The unit controller and all other electrical/electronic components should be stored in conditions of -20°F to 120°F and 5 to 95 percent relative humidity, non-condensing. Electrical components are not moisture-tolerant.

Outdoor Storage

NOTICE
Unit Corrosion Damage! Plastic tarps can cause condensation to form in and on the equipment, which could result in corrosion damage or wet storage stains. Use only canvas tarps to cover equipment.

Outdoor storage is not recommended for units that will be installed indoors. However, when outdoor storage is necessary, several things must be done to prevent damage:

Note: *Keep the equipment on the original wooden blocks/skid for protection and ease of handling.*

- Select a well-drained area, preferably a concrete pad or blacktop surface.
- Place the unit on a dry surface or raised off the ground to assure adequate air circulation beneath the unit and to assure no portion of the unit will contact standing water at any time.
- Cover the unit securely with a canvas tarp.
- Do not stack units.
- Do not pile other material on the unit.

Long-Term Storage

For longer periods of storage, allow proper clearance around the unit to perform periodic inspections and maintenance on the equipment. While the unit is in storage:

- Every two weeks, rotate the fan and motor shaft 30 revolutions by hand. Check for free rotation.
- Every six months, check fan shaft bearings and grease lines. Add grease using a manual grease gun.

Site Preparation

- Confirm the installation site can support the total weight of the unit. (See “[Dimensions and Weights](#),” p. 10 for approximate section weights; refer to the unit submittals for actual weights.)
- Allow sufficient space for adequate free air and necessary service access. (See “[Service Clearance Recommendations](#),” p. 10.) Refer to submittals for specific minimums.
- Allow room for supply and return piping, ductwork, electrical connections, and coil removal.
- Verify height meets condensate drain requirements. See “[Drain Pan Trapping](#),” p. 18.

Note: *If unit is installed in a mechanical room on a pad, inadequate height may necessitate core-drilling the floor to attain proper trap height. Insufficient height could inhibit condensate drainage and result in flooding the unit and/or equipment room.*

NOTICE

Microbial Growth!

Failure to follow instructions below could result in odors and damage to the equipment and building materials.

The floor or foundation must be level and the condensate drain at the proper height for proper drainage and condensate flow. Standing water and wet surfaces inside the equipment can become an amplification site for microbial growth (mold). If there is evidence of microbial growth on the interior insulation, it should be removed and replaced prior to operating the system.

- Confirm the foundation of the mounting platform is level and large enough to accommodate the unit. Refer to the unit submittals for specific dimensions.
- Provide adequate lighting for maintenance personnel to perform maintenance duties.
- Provide permanent power outlets in close proximity to the unit for installation and maintenance.
- Depending upon job requirements, 120 Vac power may need to be provided for the unit controller. Refer to submittals for more information. A dedicated 15-amp circuit is recommended.
- Wiring for the air handler must be provided by the installer and must comply with all national and local electrical codes.



Dimensions and Weights

Service Clearance Recommendations

Figure 2. Service clearance for indoor units

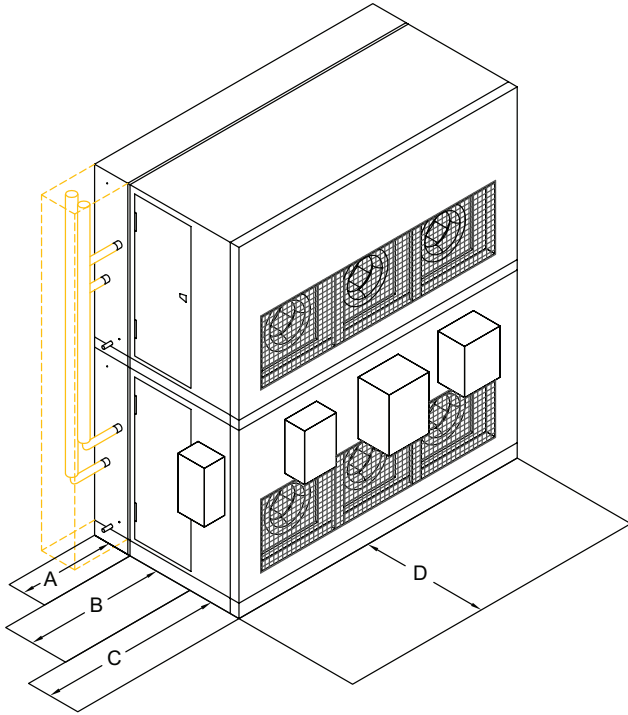

Table 1. Service clearance dimensions (inches)

Component	Width (in.)
A (Coil)	24
B (Filter and Fan)	30
C (Low Voltage Control Box)	45
D (High Voltage Boxes)	48

Note: At a minimum, the above clearance dimensions are recommended on one side of the unit for regular service and maintenance. Refer to as-built submittal for locations of items such as filter access doors, coil, piping connections, motor locations, etc. Sufficient clearance must be provided on all sides of unit for removal of access panels, plug panels, or section-to-section attachment brackets. Clearance for VFDs, or other high-voltage devices must be provided per NEC requirements. For specific dimensional and weight information, refer to the unit submittals. The dimensions and weights in this manual are approximate. Trane has a policy of continuous product and product data improvement and reserves the right to change design and specifications without notice.

Installation – Mechanical

Lifting and Rigging

General Lifting Considerations

⚠ WARNING

Heavy Objects!

Placing, assembling, and/or suspending more than one module/subassembly at a time could result in death, serious injury, or equipment damage. Always place, assemble, and suspend modules/subassemblies one at a time.

⚠ WARNING

Improper Unit Lift!

Failure to properly lift unit in a LEVEL position could result in unit dropping and possibly crushing operator/technician which could result in death or serious injury, and equipment or property-only damage.

Test lift unit approximately 24 inches (61 cm) to verify proper center of gravity lift point. To avoid dropping of unit, reposition lifting point if unit is not level.

NOTICE

Equipment Damage!

Premature skid removal could result in equipment damage.

Keep skid in place until unit is ready to set. Do not move the unit or subassembly without the skid in place as shipped from the factory.

Before preparing the unit for lifting, estimate the approximate center of gravity for lifting safety. Because of placement of internal components, the unit weight may be unevenly distributed, with more weight in the coil and fan areas. Approximate unit weights are provided in “Dimensions and Weights,” p. 10. Refer to the unit submittals for actual section weights. Test the unit for proper balance before lifting.

⚠ WARNING

Heavy Object!

Failure to follow instructions below could result in unit dropping which could result in death or serious injury, and equipment or property-only damage.

Ensure that all the lifting equipment used is properly rated for the weight of the unit being lifted. Each of the cables (chains or slings), hooks, and shackles used to lift the unit must be capable of supporting the entire weight of the unit. Lifting cables (chains or slings) may not be of the same length. Adjust as necessary for even unit lift.

Always rig subassemblies or sections as they ship from the factory. Never bolt sections together before rigging. To assist in proper placement, organize all ship splits in order of configuration before hoisting units in place.

- Make the loop of the sling parallel to the direction of airflow, if possible.
- When hoisting the unit into position, use the proper rigging method, such as straps, slings, spreader bars, or lifting lugs for protection and safety.
- Use **all** lifting lugs provided. See submittal documentation for unit lifting lug size. Use field-provided spreader bars and slings to rig units and subassemblies as shown in [Figure 3, p. 11](#). The air handler is not designed to be lifted or rigged from the top of the unit.

Figure 3. Lifting detail

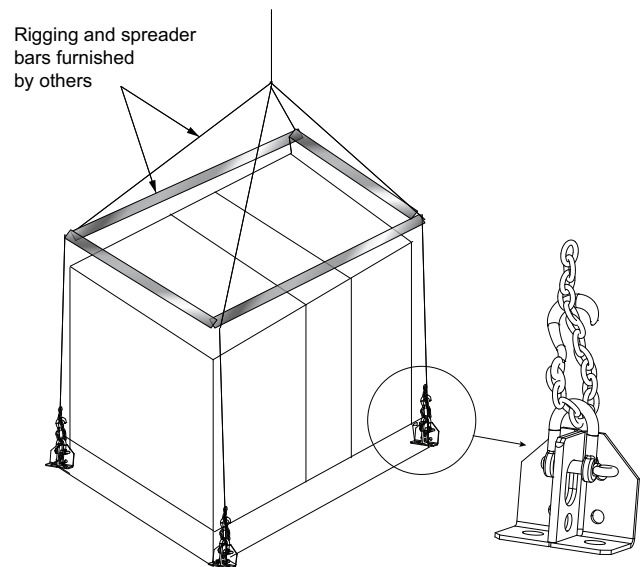

Fork lifting Considerations

NOTICE

Equipment Damage!

Improper use of fork lift could result in equipment damage.

Do not use a fork lift on air handlers or subassemblies that do not have an end cleat. Trane is not responsible for equipment damage resulting from improper fork lift practices.

Note: Do not use a forklift on outdoor air handlers or indoor air handlers/subassemblies that do not have end cleat (see [Figure 4, p. 12](#)).

A forklift may be used to lift a single section or small subassembly, provided the forks extend under both ends of the base frame, or as indicated in [Figure 4, p. 12](#). The forks should not contact the bottom of the air handler. Units

Installation – Mechanical

should only be lifted from the proper end identified by the lifting label on the unit. A lifting crane or other means should be used for larger units where forks cannot extend under both base rails

Figure 4. Fork lift points with base rail

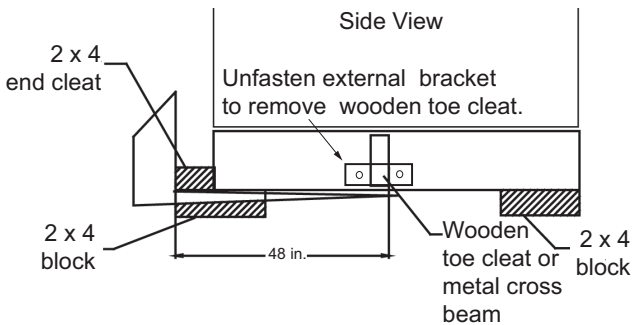

Unit Placement and Assembly

If the air handler ships in subassemblies or in individual sections, some assembly is required for section-to-section assembly.

⚠ WARNING

Heavy Objects!

Placing, assembling, and/or suspending more than one module/subassembly at a time could result in death, serious injury, or equipment damage. Always place, assemble, and suspend modules/subassemblies one at a time.

NOTICE

Equipment Damage!

Failure to follow instructions below could result in equipment damage. Do not exceed the following operating temperature limits in internal unit sections:

- Sections with electrical components: 104°F
- Sections without electrical components: 200°F

NOTICE

Microbial Growth!

Failure to follow instructions below could result in odors and damage to the equipment and building materials.

The floor or foundation must be level and the condensate drain at the proper height for proper drainage and condensate flow. Standing water and wet surfaces inside the equipment can become an amplification site for microbial growth (mold). If there is evidence of microbial growth on the interior insulation, it should be removed and replaced prior to operating the system.

If a unit arrives in sections, then each section must be individually hoisted, set on the housekeeping pad, roof curb, or pier mount and then assembled.

Refer to the unit submittals and unit tagging for correct placement of all sections. If there are any discrepancies between the submittals and the unit tagging, contact your local Trane representative before proceeding.

Following the order of the sections on the unit submittals and tagging, individually place each unassembled section or subassembly in the appropriate installation location.

For proper operation, the unit must be installed level (zero tolerance) in both horizontal axes. For vertical discharge units, allow space under the unit for supply air ductwork connections.

Note: Air handlers often include optional factory-provided casing penetration entry points for field-provided wiring. Consider overall unit serviceability and accessibility before mounting, running wires (power), making cabinet penetrations, or mounting any components to the cabinet.

See “Component Installation,” p. 17 for special assembly/installation considerations.

Removing the Shipping Skid

Remove the wooden shipping blocks, wooden toe cleat if there is one, and end cleats prior to lowering unit into final position or installing the unit to the roof curb.

Figure 5. Stacked unit assembly

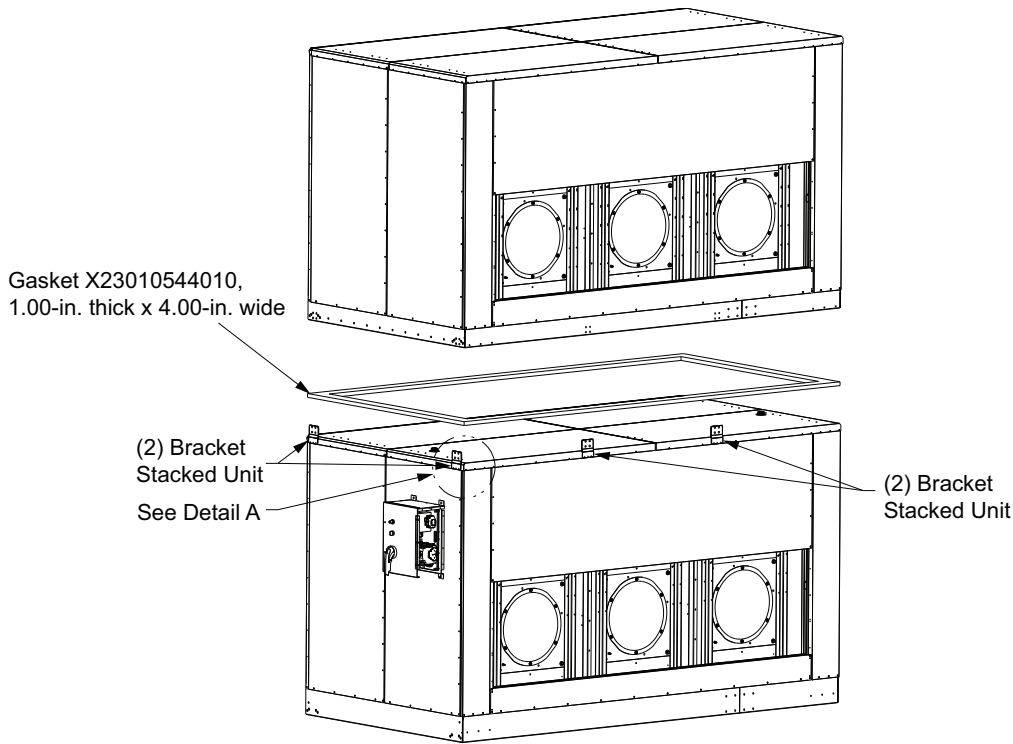

1. If the unit is equipped with factory-mounted controls, move adjacent subassembly within six inches and fasten quick connects where the sections bolt together. See Figure 5, p. 13 for low voltage. See Figure 6, p. 13 for high voltage.

Note: Reference the appropriate controller manual for more details on the installation of units with factory-mounted controls.

Figure 6. Section-to-section low voltage quick connects

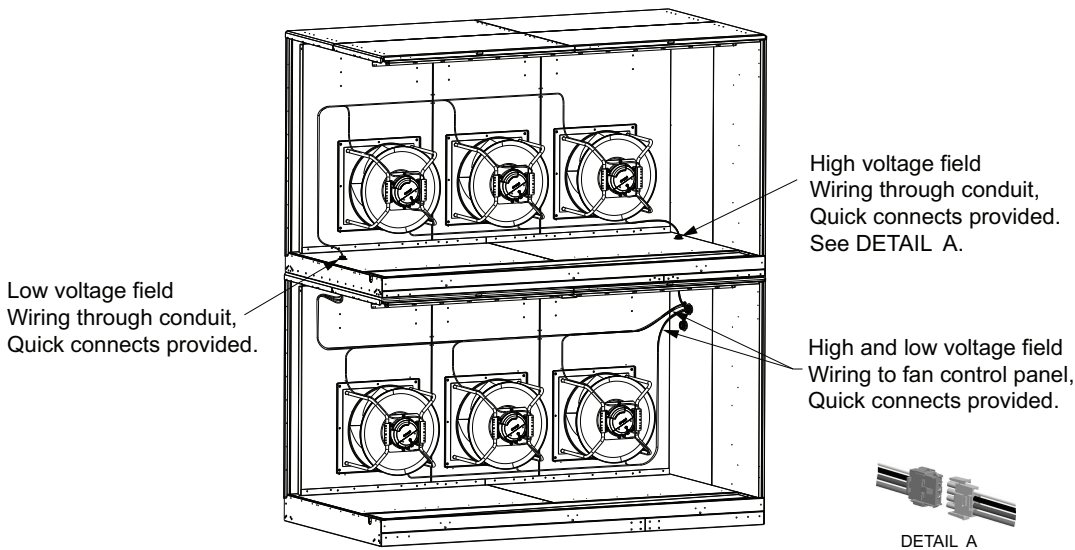

Note: Unit shown with walls hidden for clarity.

Installation – Mechanical

- Assemble and seat connections per color code.

Figure 7. Section-to-section high voltage quick connects



- Wrap each connection individually with black electrical tape.
- Fully wrap the connection with tape.

- Use a bar clamp to pull adjacent shipping section lifting lugs together.

Seismic Application Requirements

Air handling equipment manufactured by Trane is capable of structurally and operationally withstanding the seismic response criteria as required by the International Building Codes (IBC) 2000, 2003, 2006, 2009, 2012, 2015, 2018 and 2021, and CBC 2007, 2010, 2013, 2016 and 2019. Trane has third-party certification for IBC compliance for seismic applications for unit sizes 3 to 120 and stacked units.

Note: *If seismic isolation has been specified, the following requirements must be adhered to for installation. Failure to follow these instructions would void the warranty.*

Single Level Design

Grade to Roof Mounted Non-Isolated

Steel Dunnage/Steel Curb:

3/8-inch diameter ASTM A325 or SAE grade 5 bolts attached to unit base located as noted above or 1-inch long 3/16-inch welds at unit base located as noted above.

Table 2. Anchor requirements for non-stacked units

SDS	Ip	z/h	Attachment Method	Equipment Weight (lbs.)	Seismic Restraint Model	Attachment System	
						Qty per tag	Method
1.483	1.5	1.0	Floor mounted (concrete)	45 psf maximum	Bolt down	2 per mounting location	Anchor: Hilti HDA-P Dia.: M12 x 125/50 Embed.: 4.922 inches Edge: 14-in./8-in. thick Conc.: 3000 psi
0.967	1.5	1.0	Floor mounted (concrete)	45 psf maximum	Bolt down	2 per mounting location	Anchor: Hilti TZ-CS Dia.: 1/2 inch Embed.: 3.25 inches Edge: 14-in./6-in. thick Conc.: 3000 psi
1.850	1.5	1.0	Floor mounted (concrete)	45 psf maximum	Bolt down	2 per mounting location	Anchor: A325 Bolt Dia.: 1/2 inch Embed.: n/a Edge: n/a Conc.: n/a
1.850	1.5	1.0	Floor mounted (welded to steel)	45 psf maximum	Welded	1 per mounting location	6-inch weld length with 1/8-inch weld leg

Notes:

- Install clips at shipping split corners.
- Install clips at shipping splits containing fans or coils at 48 inches maximum on-center spacing.

Stacked Design

Grade to Roof Mounted ($0 \leq Sds \leq 1.85$) Non-Isolated

4000 psi Concrete:

- 1/2-inch diameter Hilti Kwik Bolt TZ carbon steel concrete anchors attached to unit base rails.
- Install clips at all ship split corners.
- Install clips at ship splits with a stacked section at 36 inches maximum on-center spacing.

- Install clips at single level ship splits containing fans or coils at 48 inches maximum on-center spacing.
- 3 1/4-inch minimum anchor embedment.
- 7 1/2-inch minimum distance to the nearest edge.
- 6-inch minimum concrete slab thickness.

Steel Dunnage/Steel Curb:

1/2-inch diameter ASTM A325 or SAE Grade 5 bolts attached to unit base located as noted above or 1-inch long 3/16-inch welds at unit bases located as noted above.

Table 3. Anchor requirements for non-stacked units

SDS	lp	z/h	Attachment Method	Equipment Weight (lbs.)	Seismic Restraint Model	Attachment System	
						Qty per tag	Method
0.421	1.5	1.0	Floor mounted (concrete)	150 psf maximum	Bolt down	See note below	1/2-in. dia. Hilti Kwik Bolts TZ-CS with min. embedment of 3-1/4-in.; Edge distance of 12-in. on 6-in. thick 3,000 psi concrete
0.637	1.5	1.0	Floor mounted (concrete)	150 psf maximum	Bolt down	See note below	Hilti HAD-P M12x125/50 bolts with min. embedment of 4.92-in.; Edge distance of 12-in. on a 8-in. thick 3,000 psi concrete
1.85	1.5	1.0	Floor mounted (steel)	150 psf maximum	Bolt down	See note below	1/2-in. dia. ASTM A325/Grade 5 bolts
1.85	1.5	1.0	Floor mounted (steel)	150 psf maximum	Welded to steel	See note below	1/8-in. thick, 6-in. long weld

Notes:

1. Install clips at shipping split corners.
2. Install anchors at shipping splits with a stacked module at 36-in. max spacing.

Anchoring

Lifting lugs should be used to anchor the unit at the ends of each shipping split. Per the anchor requirements, additional anchoring may be needed. If so, anchors will be provided and installed on the unit. An example of a seismic anchor is shown in [Figure 8, p. 15](#).

Anchor selection meets or exceeds IBC 2000, 2003, 2006, 2009, 2012, and CBC 2007, 2010 compliance requirements.

Special Inspection per IBC Section 1704 is required on all installations. All anchors listed above must be installed to meet compliance.

Figure 8. Seismic anchor

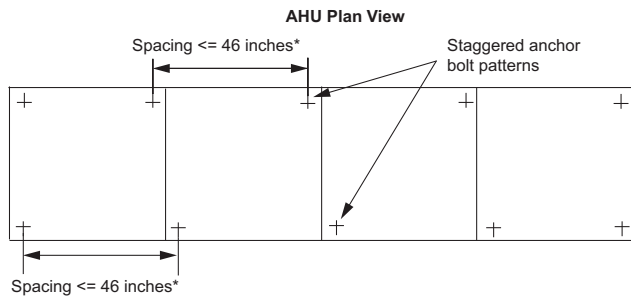

Figure 9. Seismic anchor pattern

*Only if not anchoring each functional section

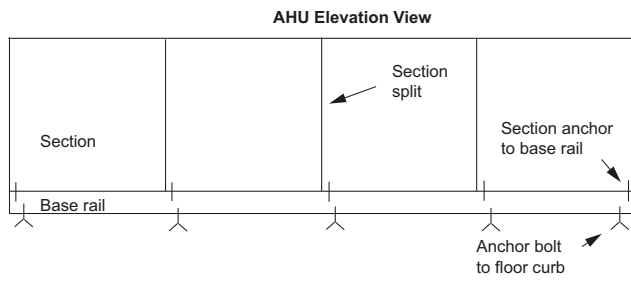



Component Installation

The components in the air handler may have installation requirements that could affect the units performance.

Filters

Filters should be installed when the unit is set. This will protect internal components, such as the heating and cooling coils.

Filter Installation

⚠ WARNING

Hazardous Voltage!

Failure to disconnect power before servicing could result in death or serious injury.

Disconnect all electric power, including remote disconnects before servicing. Follow proper lockout/tagout procedures to ensure the power can not be inadvertently energized. Verify that no power is present with a voltmeter.

To install filters:

1. Disconnect the power to the unit.
2. Open the filter section access door.
3. Slide the filters into the tracks.
4. The block-off is permanently installed and will create a

seal when the access door is closed.

5. Close the access door slowly to allow any gasketing to compress.

Figure 10. Filter rack

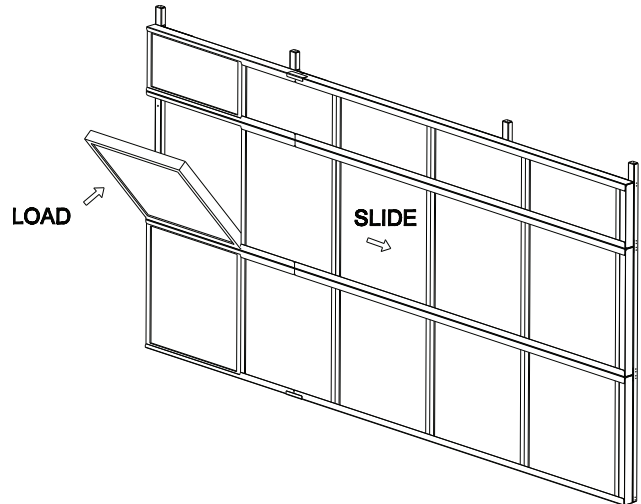

Note: Load media from front of rack. Slide media across filter track, then load additional media until row is filled. Repeat for each row.



Piping and Connections

NOTICE

Connection Leaks!

Failure to follow instructions below could result in damage to the coil header and cause connection leaks.

Use a backup wrench when attaching piping to coils with copper headers. Do not use brass connectors because they distort easily.

NOTICE

Over Tightening!

Failure to follow instructions below could result in damage to the coil header.

Do not use teflon-based products for any field connections because their high lubricity could allow connections to be over tightened.

NOTICE

Leakage!

Failure to follow instructions below could result in equipment damage.

Properly seal all penetrations in unit casing from inner to outer panel in order to prevent unconditioned air from entering the module, as well as prevent water from infiltrating the insulation.

General Recommendations

Proper installation, piping, and trapping is necessary to confirm satisfactory coil operation and to prevent operational damage:

- Support all piping independently of the coils.
- Provide swing joints or flexible fittings on all connections that are adjacent to heating coils to absorb thermal expansion and contraction strains.
- If the coil was ordered with factory-mounted controls, install the control valves. The valves ship separately.

Note: The contractor is responsible for supplying the installation hardware.

- For best results, use a short pipe nipple on the coil headers prior to making any welded flange or welded elbow type connections.
- Extended drain and vent connections are provided as standard on D1 and D2 coils only. If extended drains and vents are required on other water coils, they must

be field-installed or ordered as specials from the factory.

- Pipe coils counterflow to airflow.
- When attaching the piping to the coil header, make the connection only tight enough to prevent leaks.

Note: Do not exceed 200 foot-pounds of torque on supply and return connections. Do not exceed 25 foot-pounds of torque on drain and vent connections.

- Use pipe sealer on all thread connections.
- After completing the piping connections, seal around pipe from inner panel to outer panel.

Drain Pan Trapping

⚠ WARNING

No Step Surface!

Failure to follow instruction below could result in death or serious injury.

Do not walk on the sheet metal drain pan. Walking on the drain pan could cause the supporting metal to collapse and result in the operator/technician falling.

NOTICE

Water Damage!

Failure to follow instructions below could result in water damage.

When more than one section has a drain pan, trap each section individually. Connecting multiple drains to a common line with only one trap could result in condensate retention and water damage to the air handler or adjoining space.

Threaded condensate drain connections are provided on only one side of the coil section. Pitch the connection lines horizontal or downward toward an open drain. Trane recommends installing a plug to facilitate cleaning of the trap. The drain connection sizes are:

Figure 11, p. 19 illustrates the proper trapping, piping, and operation of the trap. Use the formula under the figure to determine the correct minimum depth for the condensate trap. If a section has a drain pan for cleaning purposes only, it does not need a trap; however, a cap or shutoff valve should be installed on the drain connection. Only sections handling condensate, such as a cooling coil section or moisture eliminator section, require a trap.

Figure 11. Drain pan trapping for negative and positive pressure applications

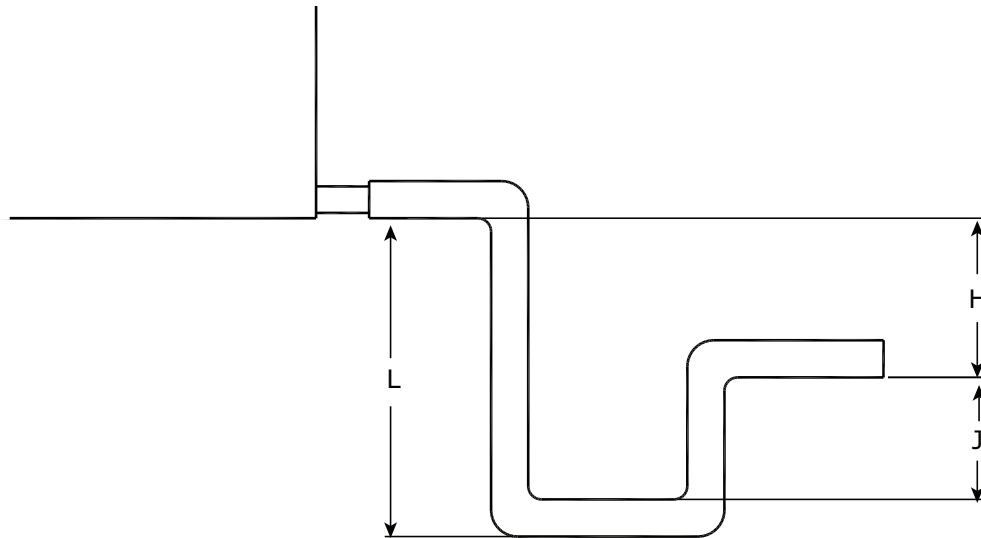

Section under negative pressure

$L = H + J + \text{pipe diameter}$ where:
 $H = 1 \text{ inch}$ for each inch of negative pressure plus 1 inch with loaded filters
 $J = 1/2 H$

Section under positive pressure

$L = H + J + \text{pipe diameter}$ where:
 $H = 1/2 \text{ inch}$ (minimum)
 $J = 1/2 \text{ inch}$ plus the unit positive static pressure at coil discharge (loaded filters)

Piping Package

Factory-engineered piping package provides single points of connection for the cooling coil supply and returns. Piping package includes control valves on the return side of each coil.

Piping package ships direct to jobsite. Piping assembly and installation field-installed. Refer to the submittal for equipment-specific valve selection, pipe size, and configuration details.

Piping support structure must be provided by the installer and comply with all national and local plumbing codes. Piping weight must be supported independently of the air handling unit.

Figure 12. AHU coil connections

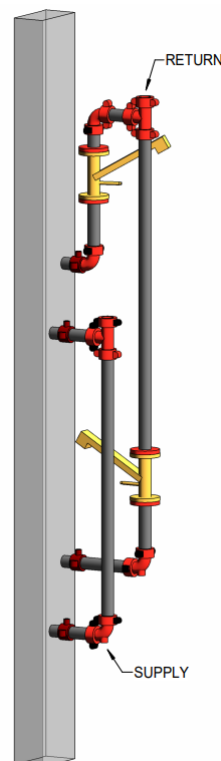

Water Coil Piping

Water coils are self-venting only if the water velocity exceeds 1.5 feet per second (fps) in the coil tubes. See the unit submittals for coil water velocity. If the water velocity is below these minimums, vent the coil by one of the following methods:

1. Install an air vent in the top pipe plug tapping of the return header.
2. When the return line rises above the top of the coil, vent from the top of the return header horizontally to the return piping.

Note: TT coils are designed with larger than normal end tube sheet holes to allow for maximum expansion. Air leakage around tubes should be expected and handled by capping over coil ends or by sealing around tubes with a pliable sealant such as silicone.

Figure 13. Typical piping for stacked water coils

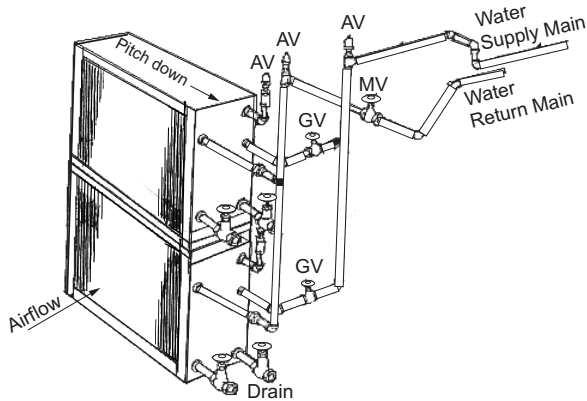

Note: Coils shown with factory and field-provided piping.

Fan Coil Wall Package Installation

The piping package comes in two separate assemblies—supply and return.

Piping Installation

The supply and return piping packages attach to the AHU headers using Victaulic style 72 outlet couplings. Refer to the I-100 Field installation handbook supplied by Victaulic and the TA-Slider 750 actuator installation manual supplied with the actuator, as needed.

For **supply** piping packages, refer to steps 1 through 6.

For **return** piping packages, refer to steps 1 through 9.

1. Check the mating component ends as follows:
 - a. Check the AHU header, which should be mostly free of indentations, projections, weld-seam anomalies, and roll marks to verify a leak-tight seal.

- b. Remove all oil, grease, loose paint, dirt, and cutting particles.

Supply headers will always be located closer to the air-leaving side and at the bottom of the build group.

Return headers will always be located closer to the air-entering side and at the top of the build group.

Figure 14. Supply and return headers

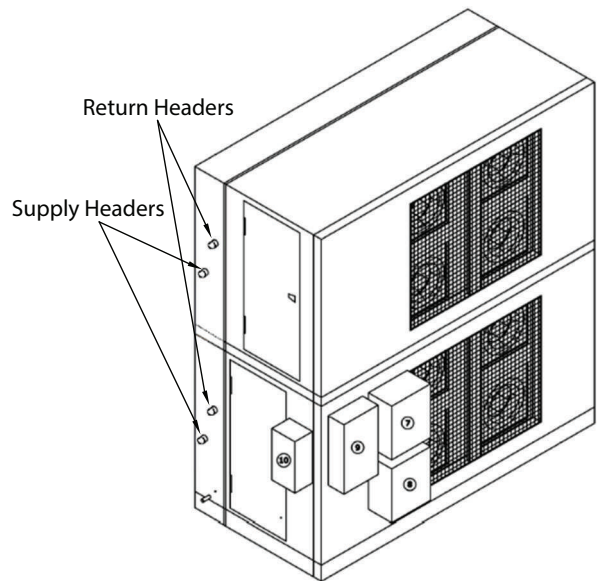

2. Loosen the outlet coupling housing bolts uniformly to allow the AHU header to push into the coupling.

Figure 15. Loosen the outlet coupling bolts



3. Apply a thin coat of a compatible lubricant to the gasket sealing lips and exterior.

Refer to the Lubricant Compatibility for Gaskets table in the Victaulic field installation handbook.

4. Align the piping package outlet coupling with the AHU headers and seat the piping package onto the AHU headers.

The end of the header should align with the gasket.

Figure 16. Insert the pipe into the header



5. Install the pipe bracing and support using the two bolts and two nuts.

Figure 17. Secure the pipe to the header



6. Tight the nuts evenly by alternating sides, maintaining uniform bolt pad gaps until there is metal-to-metal contact at the bolt pads.

Figure 18. Tighten the nuts evenly

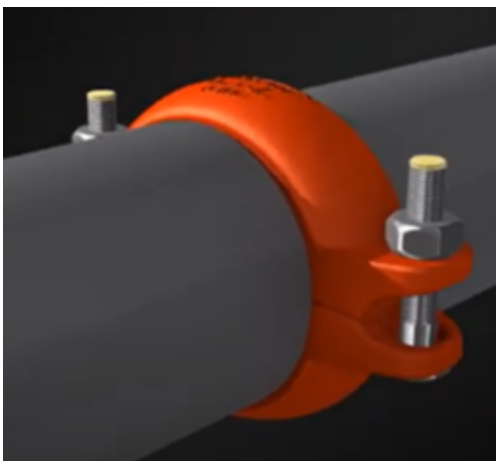

7. Inspect each bolt pad location at each joint to verify that there is metal-to-metal contact across the entire bolt pad section.

Figure 19. Metal-to-metal contact across the bolt pad section



Actuator Installation

1. For return piping packages only, secure the actuators to the control valve using two bolts (M8 x 25 mm). Torque the bolts to 88.5 in-lb.

Figure 20. Install the actuator

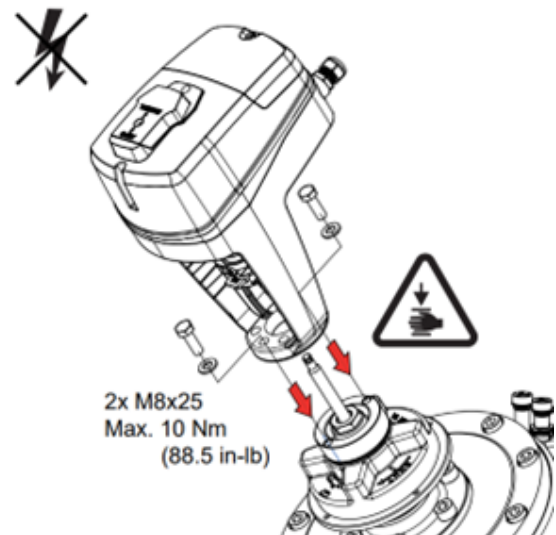

2. Set the actuator to manual mode by pushing the slider on the top of the actuator forward.
3. Push the spring-loaded stem retention tab inward to lock the actuator in manual mode.

Figure 21. Push the slider forward and insert the Allen wrench

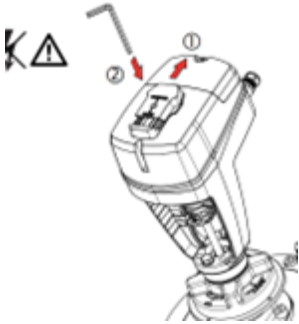

- Using a #5 Allen wrench, turn clockwise to shift the actuator downward.

Figure 22. Turn the Allen wrench clockwise

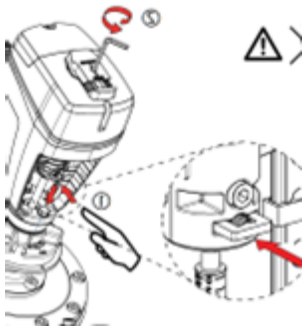

- When the stem seats correctly into the actuator retention tab, it will automatically release and snap into place.

Figure 23. Retention tab snapping into place

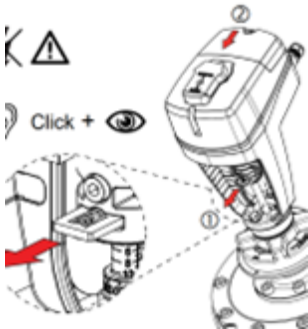

- Set the actuator to automatic mode.

Actuator Wiring

- Using a Phillips-head screwdriver, remove the actuator wire housing cover.

Figure 24. Remove the housing

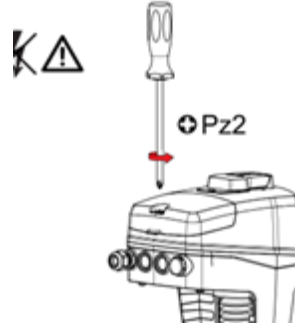

- Remove the harness-retention nut and feed the harness through the hole in the actuator.

Figure 25. Remove the retention nut

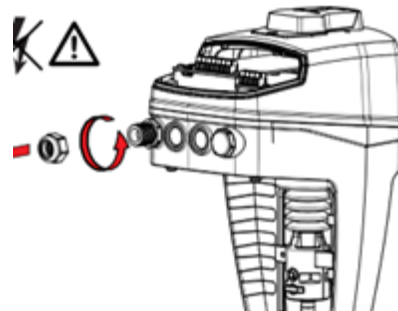
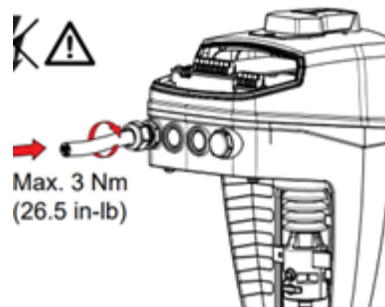
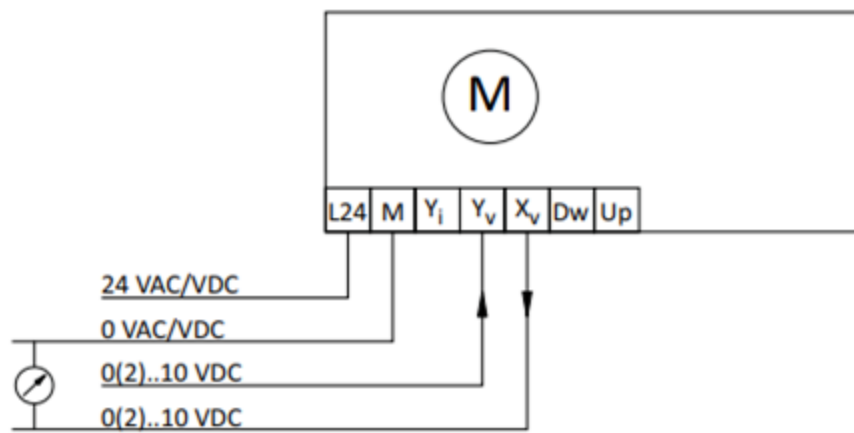

Figure 26. Install the harness



- Install the retention nut.
- Install the wires as shown in the wiring diagram below. The wires from the actuator are routed to the junction box on the unit wall.

Figure 27. Wiring diagram—unit connection 9-pin connector



5. Secure the connections appropriately.

Installation – Electrical

⚠ WARNING

Hazardous Voltage w/Capacitors!

Failure to disconnect power and discharge capacitors before servicing could result in death or serious injury.

Disconnect all electric power, including remote disconnects and discharge all motor start/run capacitors before servicing. Follow proper lockout/tagout procedures to ensure the power cannot be inadvertently energized. Verify with a CAT III or IV voltmeter rated per NFPA 70E that all capacitors have discharged.

⚠ WARNING

Electrical Shock Hazard!

Failure to follow instructions below could result in death or serious injury.

Properly connect the system's oversized protective earthing (grounding) terminal(s).

NOTICE

Use Copper Conductors Only!

Failure to use copper conductors could result in equipment damage as the equipment was not designed or qualified to accept other types of conductors.

Note: Air handlers often include optional factory-provided casing penetration entry points for field-provided wiring. Consider overall unit serviceability and accessibility before mounting, running wires (power), making cabinet penetrations, or mounting any components to the cabinet.

Units intended for indoor use are available with an externally mounted motorized impeller control panel enclosure (MICB).

A typical externally mounted MICB is shown in [Figure 28](#), [p. 24](#).

Figure 28. Externally mounted MICB



A typical wiring schematic for a MICB is shown in . Unit specific wiring schematics are shipped with each unit.

MICBs have a control selection switch that provides fan speed control automatically through the low volt unit controller, as shown in [Figure 29](#), [p. 25](#), or manually using a potentiometer.

Figure 29. Externally mounted controller



Typical Wiring Schematics

Refer to the submittal for job-specific schematics.



Controls Interface

The portable operator display is used for temporary connection to and operation of Trane Symbio™ controller. With the portable operator display, you can monitor data, change setpoints, monitor alarms, and override points. The portable operator display includes a 10 ft (3 m) cable with connector that is stored in the storage compartment of the carrying bag. The cable cannot be disconnected from the operator display. Keep this document with the portable operator display for access to calibration and cleaning instructions.

Note: *The portable operator display is not used for timeclock scheduling. To provide scheduling you must use a Tracer Summit system.*

Connecting the Operator Display

To connect the portable operator display:

1. Locate the factory-provided service module.
2. Attach the operator-display cable to the operator-display connector on the service module. The operator display receives power from the controller and turns on automatically when it is connected.

NOTICE

Display Damage!
Failure to follow instructions below could result in damage to the display.
Use a cloth dampened with commercial liquid glass cleaner to clean the operator display. Do not spray water or cleaner directly on screen.

Calibrating the Operator Display

This section shows how to calibrate the operator display touch screen and how to adjust the brightness and contrast. To set up the operator display screens and security, see the *Tracer® TD7 Display Installation Instructions* (BAS-SVN112*-EN).

To calibrate the operator display:

1. On the home screen, press **Setup**. The **Setup** menu appears.
2. Page down to view the next screen.
3. Press **Calibrate Touch Screen**. A calibration screen appears.

NOTICE

Equipment Damage!
Failure to follow instructions below could result in equipment damage.
Protect operator display from contact with sharp objects.

4. Touch the target using a small, pliable, blunt object, such as a pencil eraser or your finger. Hold until the beeping stops. A second calibration screen appears.
5. Again, touch the target with the object. Hold until the beeping stops. The **Advanced Selection** screen appears.
6. Press **Home**. The home screen appears.

Adjusting Brightness and Contrast

To adjust the brightness and contrast of the operator display:

1. On the home screen, press **Setup**. The **Setup** menu appears.
2. Page down to view the next screen.
3. Press the **Adjust Brightness** and **Contrast** buttons. The **Brightness and Contrast** screen appears.
4. To increase the brightness, press the buttons along the top row, in sequence, from left to right. To decrease the brightness, press the buttons from right to left.
Note: *Contrast adjustment is not available on all computer display models.*
5. To increase the contrast, press the buttons along the bottom row, in sequence, from left to right. To decrease the contrast, press the buttons from right to left.
6. Press **Home**. The home screen appears.

External Communications Port

Units with a factory-provided DDC controller can include a service module with an external communications port when purchased. Both the operator display and Tracer® TU service tool can be connected without shutting off the unit through the external communications port. Open the cover plate on the service module and plug into the RJ-45 port for the operator display or the USB port for the Tracer TU service tool. This enables continuous operation of the air handler without disruption to the operating conditions of the unit. When servicing of the unit is complete, close the cover plate on the service module to eliminate any air leakage path.



Start-Up

Pre-Startup Checklist

Once the air handler has been assembled and installed, attention must be directed to individual components for proper operation. Before operating the unit, complete the pre-startup checklist.

⚠ WARNING

Hazardous Voltage w/Capacitors!

Failure to disconnect power and discharge capacitors before servicing could result in death or serious injury.

Disconnect all electric power, including remote disconnects and discharge all motor start/run capacitors before servicing. Follow proper lockout/tagout procedures to ensure the power cannot be inadvertently energized. Verify with a CAT III or IV voltmeter rated per NFPA 70E that all capacitors have discharged.

General Checks

- Verify the unit installation is level.
- Check that air filters are in place and positioned properly.
- Remove any debris from the unit interior.
- Remove all foreign material from the drain pan and check drain pan opening and condensate line for obstructions.
- Close and secure all unit access doors.
- If differential pressure switch is provided on filter rack, adjust per system requirements.
- Inspect electrical connections to the unit and unit controllers.
 - Connections should be clean and secure.
 - Compare the actual wiring with the unit diagrams.
 - Reference the appropriate controller manual for more details about starting units with factory-mounted controls.
- Check piping and valves for leaks. Open or close the valves to check for proper operation. Drain lines should be open.
- Leave this manual with the unit.

Fan-Related Checks

- Rotate all fan wheels manually to confirm they turn freely in the proper direction.
- Inspect fan motor and bearings for proper lubrication.

Coil-Related Checks

NOTICE

Proper Water Treatment Required!

The use of untreated or improperly treated water could result in scaling, erosion, corrosion, algae or slime.

Use the services of a qualified water treatment specialist to determine what water treatment, if any, is required. Trane assumes no responsibility for equipment failures which result from untreated or improperly treated water, or saline or brackish water.

- Verify coil and condensate drain piping connections are complete.
- Check the piping and valves for leaks.
 - Open or close the valves to check operation.
 - The drain lines should be open.
- Remove all foreign material from the drain pan and check the pan opening and condensate line for obstructions.

Fan Inlet Airflow Measuring System

A fan inlet airflow measuring system (piezometer) is available on many centrifugal and plenum fans. Tranes system determines airflow using a static pressure differential.

Note: This type of system is different than a total pressure or thermal dispersion system. As such, the calculations will be different.

Each system comes with a differential pressure transmitter. The minimum diameter is connected to the LO port of the transmitter and the reference pressure point is connected to (or actually is) the HI port of the transmitter.

Figure 31. Fan inlet airflow measuring system



Wiring

The transmitter requires 24 Vdc/24 Vac power on terminals 1 (+) and 2 (ground) of the transmitter. When the airflow measurement system is ordered with a factory-mounted Symbio™ controller, the 24 Vdc power will be supplied.

In the absence of a factory-mounted Symbio controller, the installing contractor must confirm the transmitter has 24 Vdc/24 Vac power.

Transmitter Sizing

The Trane specification requires that the flow meter option have a total accuracy of 5 percent. The total accuracy is a combination of:

- How accurately the flow meter itself is in sensing airflow.
- How accurately the transmitter senses the differential pressure.
- How accurately the controller translates the signal from the transmitter to a differential pressure.

Selecting the proper transmitter is critical in order to get accurate airflow measurements. How accurately the transmitter senses the differential pressure is dependent on:

- The pressure range selected
- The accuracy of the selected transmitter

Trane air handlers use a 0 to 5 inch, 0 to 10 inch, or 0 to 25 inch w.g. range transmitter as standard. To sufficiently cover VAV turndown on the smallest fans with the above range, a transmitter with an accuracy of 0.25 percent (full scale) is used as standard. If a field-provided transmitter with a lower accuracy is selected, the range should be chosen closer to the actual, maximum pressure differential expected for the application.

The transmitter outputs a signal that represents the differential pressure which is used to calculate airflow. To adequately calculate and display the airflow for the smaller fans, verify the analog input is programmed with enough decimal places to sufficiently represent the pressure differential being measured.

Note: *The transmitter is factory-calibrated to the range selected and cannot be significantly adjusted to tighten the range closer to the pressure being read for the given application.*

Transmitter Calibration

The transmitter is factory-calibrated to a specific pressure range with a 0 to inch, 0 to 10 inch, or 0 to 25 inch w.g.

Table 4. Constant K factors

Fan Size (inches)/Type	Fan Class	Fan Name	K-Factor
17.70 Full-Width Impeller Fan	Any	17FM	2231
19.70 Full-Width Impeller Fan	Any	19FM	2612

range being used in most cases. To check calibration and to adjust if necessary, consult the transmitter manufacturer or the factory for specific procedures.

The transmitter outputs a linear, 2 to 10 Vdc signal representing a differential pressure measurement. With this measurement, the airflow through the fan can be calculated using the following equation:

$$CFM = K * \text{SQRT}(DP)$$

Where:

CFM = Airflow (ft³/min.) assuming a standard air density of 0.075 lbm/ft³.

K = A constant factor that is unique for each fan. See "Constant K Factor," p. 29 for more information.

DP = Differential pressure (inches w.g.) being measured by the transmitter.

Significant differences in elevation and/or temperature will affect the density of air. For air at a constant, non-standard density, a field-obtained K factor can be used. Alternatively, the following equation can be used to continuously correct the equation above:

$$ACFM = CFM * \text{SQRT}(0.075/\rho)$$

Where:

ACFM = Actual airflow (ft³/min.) corrected for non-standard air density.

ρ = Density (lbm/ft³) of the air at the inlet to the fan.

Note: *Alternative units, including SI, can be used in place of the IP units above although the K-factor must be converted appropriately.*

Maintenance

For a typical HVAC environment - especially with upstream filtration - there should be little to no required maintenance. In extreme cases or for mishaps (bearing grease in the taps for example), the flow meter is easily cleanable. The fan inlet airflow measuring system is extremely simple: a few pressure taps, a few fittings, and some tubing. Although unlikely, if any tap were to get clogged, simply disconnect each side of the transmitter and blast air in a reverse direction through the system.

Constant K Factor

The constant K factor is unique for each fan and is primarily a function of the area and other geometric properties of the fan inlet. Pre-engineered factors are available from the factory for fan types where the airflow measurement system is available.



Start-Up

Table 4. Constant K factors (continued)

Fan Size (inches)/Type	Fan Class	Fan Name	K-Factor
22.00 Full-Width Impeller Fan	Any	22FM	3233
24.80 Full-Width Impeller Fan	Any	24FM	4071

Note: This table to be used for the updated tap design - mid-2014 and beyond. Refer to prior editions of this publication for the previous design.

When a single transmitter is supplied in a multiple fan system, one or more fans will be brought back to the transmitter as a manifold and the airflow will represent the total airflow for the system. As a result, the factor should be adjusted as follows:

$$K = N * K\text{-Factor from Table 4, p. 29.}$$

Where:

K = The final factor to be used for controller programming.

N = The number of active* fans in the system.

*If a fan fails in a multiple fan system where only one transmitter is being supplied, and if the remaining fans will continue to be used, the factor should be reduced accordingly. Additionally, if the inactive fan was included in the manifold back to the transmitter, the tubes from the inactive fan should be temporarily removed and replaced with tubes from an active fan (or simply plugged).

When a transmitter is supplied for each fan, the factor does not need to be adjusted. The resulting airflow will represent single-fan airflow. At the controller level, the individual airflows should be summed to get the total airflow. If a field-provided K-factor is to be used (see below), the measured airflow for the system should be divided by the number of active fans to get a single-fan K-factor.

Field-obtained factors can provide maximum accuracy. To obtain the factor in the field, measure the differential pressure output from the transmitter while measuring the airflow through the system. Once these two values have been measured, simply solve for K using the following equation:

$$K = ACFM / \sqrt{DP}$$

Where:

K = Field-provided constant factor.

ACFM = Actual airflow (ft³/min.) being measured at the air density being measured.

DP = Differential pressure (inches w.g.) being measured by the transmitter.

External Insulating Requirements

The following areas should be specifically addressed, as applicable:

- Supply and return water piping connections
- Condensate drain lines and connections



Routine Maintenance

⚠ WARNING

Hazardous Service Procedures!

Failure to follow all precautions in this manual and on the tags, stickers, and labels could result in death or serious injury.

Technicians, in order to protect themselves from potential electrical, mechanical, and chemical hazards, **MUST** follow precautions in this manual and on the tags, stickers, and labels, as well as the following instructions: Unless specified otherwise, disconnect all electrical power including remote disconnect and discharge all energy storing devices such as capacitors before servicing. Follow proper lockout/tagout procedures to ensure the power can not be inadvertently energized. When necessary to work with live electrical components, have a qualified licensed electrician or other individual who has been trained in handling live electrical components perform these tasks.

⚠ WARNING

Rotating Components!

Failure to disconnect power before servicing could result in rotating components cutting and slashing technician which could result in death or serious injury.

During installation, testing, servicing and troubleshooting of this product it may be necessary to work with live and exposed rotating components. Have a qualified or licensed service individual who has been properly trained in handling exposed rotating components, perform these tasks.

Maintenance Checklist

Table 5. Maintenance checklist

Frequency	Maintenance
Every Week	Observe unit weekly for any change in running condition and unusual noise.
Every Month	Clean or replace air filters if clogged or dirty; coat permanent filters with oil after cleaning; change bag filters when pressure drop is 1 in. w.g. See "Filters," p. 34 for more information.
Every Three to Six Months	<ul style="list-style-type: none"> Inspect and clean drain pans. See "Drain Pans," p. 33 for more information. Tighten electrical connections. Inspect coils for dirt build-up. See "Coils," p. 32 for more information.
Every Year	<ul style="list-style-type: none"> Inspect the unit casing for corrosion. If damage is found, clean and repaint. Clean the fan wheels. See "Fans," p. 34 for more information. Inspect and clean drain pans. Inspect electrical components and insulation. Inspect wiring for damage. Rotate the fan wheel and check for obstructions. The wheel should not rub. Adjust the center if necessary. Check condition of gasketing and insulation around unit, door and dampers.

Cleaning the Unit

Cleaning Non-Porous Surfaces

⚠ WARNING

Hazardous Voltage!

Failure to disconnect power before servicing could result in death or serious injury.

Disconnect all electric power, including remote disconnects before servicing. Follow proper lockout/tagout procedures to ensure the power can not be inadvertently energized. Verify that no power is present with a voltmeter.

If microbial growth on a non-porous insulating surface

(closed cell insulation or sheet metal surface) is observed:

1. Disconnect all electrical power to the unit.
2. Wearing the appropriate personal protective equipment, use a brush for sheet metal surfaces or a soft sponge on a foil face or closed cell foam surface to mechanically remove the microbial growth.
Note: Be careful not to damage the non-porous surface of the insulation.
3. Thoroughly clean the contaminated area(s) with an EPA-approved sanitizer specifically designed for HVAC use.
4. Rinse the affected surfaces thoroughly with fresh water and a fresh sponge to prevent potential corrosion of the drain pan and drain line.



Routine Maintenance

- Repeat [Step 3](#) and [Step 4](#) as necessary.
- Confirm the drain line is open following the cleaning process.
- Allow the unit to dry thoroughly before putting it back into service.
- Replace all panels and parts and restore electrical power to the unit.
- Be careful any contaminated material does not contact other areas of the unit or building. Properly dispose of all contaminated materials and cleaning solution.

Cleaning Porous Surfaces

⚠ WARNING

Hazardous Voltage!

Failure to disconnect power before servicing could result in death or serious injury.

Disconnect all electric power, including remote disconnects before servicing. Follow proper lockout/tagout procedures to ensure the power can not be inadvertently energized. Verify that no power is present with a voltmeter.

To clean a porous insulating surface (fiberglass insulation):

- Disconnect all electrical power to the unit.
- Wearing the appropriate personal protective equipment, use a vacuum device with a HEPA filter (99.97 percent efficient at 0.3 micron particles) to remove the accumulated dirt and organic matter.
Note: Be careful not to tear the insulation surface or edges.
- Confirm the drain line is open following the cleaning process.
- Allow the unit to dry thoroughly before putting it back into service.
- Replace all panels and parts and restore electrical power to the unit.
- Be careful any contaminated material does not contact other areas of the unit or building. Properly dispose of all contaminated materials and cleaning solution.

Coils

All coils should be kept clean to maintain maximum performance.

Water Coils

⚠ WARNING

Hazardous Voltage!

Failure to disconnect power before servicing could result in death or serious injury.

Disconnect all electric power, including remote disconnects before servicing. Follow proper lockout/tagout procedures to ensure the power can not be inadvertently energized. Verify that no power is present with a voltmeter.

⚠ WARNING

Hazardous Chemicals!

Failure to follow this safety precaution could result in death or serious injury. Coil cleaning agents can be either acidic or highly alkaline and can burn severely if contact with skin or eyes occurs.

Handle chemical carefully and avoid contact with skin. ALWAYS wear Personal Protective Equipment (PPE) including goggles or face shield, chemical resistant gloves, boots, apron or suit as required. For personal safety refer to the cleaning agent manufacturer's Materials Safety Data Sheet and follow all recommended safe handling practices.

To clean water coils:

- Disconnect all electrical power to the unit.
- Wearing the appropriate personal protective equipment, use a soft brush to remove loose debris from both sides of the coil.
- Install a block-off to prevent spray from going through the coil and into a dry section of the unit and/or system ductwork.
- Mix a high-quality coil cleaning detergent with water according to the manufacturers instructions.
Note: If the detergent is strongly alkaline after mixing (pH 8.5 or higher), it must contain an inhibitor. Follow the cleaning solution manufacturers instructions regarding the use of the product.
- Place the mixed solution in a garden pump-up sprayer or high-pressure sprayer. If a high pressure sprayer is to be used:
 - Maintain minimum nozzle spray angle of 15°.
 - Spray perpendicular to the coil face.
 - Keep the nozzle at least 6 inches from the coil.
 - Do not exceed 600 psi.
- Spray the leaving air side of the coil first, then the entering air side.
- Thoroughly rinse both sides of the coil and the drain pan with cool, clean water.
- Repeat [Step 6](#) and [Step 7](#) as necessary.
- Straighten any coil fins that may have been damaged

during the cleaning process.

10. Confirm the drain line is open following the cleaning process.
11. Allow the unit to dry thoroughly before putting it back into service.
12. Replace all panels and parts and restore electrical power to the unit.
13. Be careful any contaminated material does not contact other areas of the unit or building. Properly dispose of all contaminated materials.

Coil Winterization

Water coil winterization procedures consist primarily of draining water from the coil before the heating season. Trane recommends flushing the coil with glycol if coils will be exposed to temperatures below 35°F.

NOTICE

Coil Freeze-Up!

Failure to follow instruction below could result in equipment damage.

Drain and vent coils when not in use. Trane recommends glycol protection in all possible freezing applications. Use a glycol approved for use with commercial cooling and heating systems and copper tube coils.

Install field-fitted drains and vents to permit winterization of coils not in use and to assist in evacuating air from the water system during startup. If draining is questionable because of dirt or scale deposits inside the coil, fill the coil with glycol before the heating season begins.

Individual coil types determine how to properly winterize the coil. To determine the coil type find the Service Model No of Coil on the coil section nameplate. The coil type is designated by the second and third digits on that model number. For example, if the model number begins with DUWB, the coil type is UW; if the model number begins with DW0B, the coil type is W.

Note: *On many unit sizes, there are multiple coils in the coil section. Be sure to winterize all coils in a given coil section.*

To winterize water coils:

1. Remove the vent and drain plugs.
2. Blow the coil out as completely as possible with compressed air.
3. Fill and drain the coil several times with full strength glycol so that it mixes thoroughly with the water retained in the coil.
4. Drain the coil out as completely as possible.
5. To confirm no water remains in the coil, do not replace the vent and drain plugs until the coils are put back into service.

Moisture Purge Cycle

Any HVAC unit with a cooling coil serves as a dehumidifier, reducing the surrounding air's ability to hold water vapor as its temperature falls. This normally does not present a problem when the unit is running. However, when the fan stops, water vapor condenses on the cold metal surfaces inside the air handler and remains there until the air warms sufficiently to re-evaporate it. This damp, dark environment — though temporary — can encourage the growth of mold, mildew, and other microbial contaminants.

Providing a moisture purge cycle 15 to 30 minutes after shutdown disperses the cold, humid air inside the air-handling system more evenly throughout the building. This four-step cycle:

- Closes the outdoor air dampers.
- Turns off the cooling coil.
- Opens any variable-air-volume terminals connected to the air handler.
- Operates the supply fan for 10 to 15 minutes.

Air movement discourages water condensation and hastens re-evaporation of any condensate that does happen to form. This simple preventative measure effectively combats microbial growth and curbs moisture-related deterioration of air-handling components.

Drain Pans

⚠ WARNING

Hazardous Chemicals!

Failure to follow this safety precaution could result in death or serious injury. Coil cleaning agents can be either acidic or highly alkaline and can burn severely if contact with skin or eyes occurs.

Handle chemical carefully and avoid contact with skin. ALWAYS wear Personal Protective Equipment (PPE) including goggles or face shield, chemical resistant gloves, boots, apron or suit as required. For personal safety refer to the cleaning agent manufacturer's Materials Safety Data Sheet and follow all recommended safe handling practices.

⚠ WARNING

No Step Surface!

Failure to follow instruction below could result in death or serious injury.

Do not walk on the sheet metal drain pan. Walking on the drain pan could cause the supporting metal to collapse and result in the operator/technician falling.

The condensate drain pan and drain line must be checked to assure the condensate drains as designed. This inspection should occur a minimum of every six months or more often as dictated by operating experience.

If evidence of standing water or condensate overflow exists, identify and remedy the cause immediately. Refer to



Routine Maintenance

“Troubleshooting,” p. 35 for possible causes and solutions.

To clean drain pans:

1. Disconnect all electrical power to the unit.
2. Wearing the appropriate personal protective equipment, remove any standing water.
3. Scrape solid matter off of the drain pan.
4. Vacuum the drain pan with a vacuum device that uses high-efficiency particulate arrestance (HEPA) filters with a minimum efficiency of 99.97 percent at 0.3 micron particle size.
5. Thoroughly clean any contaminated area(s) with a mild bleach and water solution or an EPA-approved sanitizer specifically designed for HVAC use.
6. Immediately rinse the affected surfaces thoroughly with fresh water and a fresh sponge to prevent potential corrosion of metal surfaces.
7. Allow the unit to dry completely before putting it back into service.
8. Be careful any contaminated material does not contact other areas of the unit or building. Properly dispose of all contaminated materials and cleaning solution.

Fans

⚠ WARNING

Rotating Components!

Failure to secure rotor or disconnect power before servicing could result in rotating components cutting and slashing technician which could result in death or serious injury.

The following procedure involves working with rotating components.

- Disconnect all electric power, including remote disconnects before servicing.
- Follow proper lockout/tagout procedures to ensure the power cannot be inadvertently energized.
- Secure rotor to ensure rotor cannot freewheel.

Inspecting and Cleaning Fans

Fan sections of air handlers should be inspected every six months at a minimum or more frequently if operating experience dictates. If evidence of microbial growth (mold) is found, identify and remedy the cause immediately. Refer to “Troubleshooting,” p. 35 for possible causes and solutions. To clean the fan section:

1. Disconnect all electrical power to the unit.
2. Wearing the appropriate personal protective equipment, remove any contamination.
3. Vacuum the section with a vacuum device that uses high-efficiency particulate arrestance (HEPA) filters with a minimum efficiency of 99.97 percent at 0.3 micron particle size.
4. Thoroughly clean any contaminated area(s) with a mild bleach and water solution or an EPA-approved sanitizer specifically designed for HVAC use.
5. Immediately rinse the affected surfaces thoroughly with fresh water and a fresh sponge to prevent potential corrosion of metal surfaces.
6. Allow the unit to dry completely before putting it back into service.
7. Be careful any contaminated material does not contact other areas of the unit or building. Properly dispose of all contaminated materials and cleaning solution.

Fan Motor Inspection

Inspect the fan motors periodically for excessive vibration or temperature.

The fan motor is equipped with permanently-lubricated bearings that do not require routine maintenance.

Filters

⚠ WARNING

Rotating Components!

Failure to secure rotor or disconnect power before servicing could result in rotating components cutting and slashing technician which could result in death or serious injury.

The following procedure involves working with rotating components.

- Disconnect all electric power, including remote disconnects before servicing.
- Follow proper lockout/tagout procedures to ensure the power cannot be inadvertently energized.
- Secure rotor to ensure rotor cannot freewheel.

Throwaway Filters

To replace throwaway filters, install new filters with the directional arrows pointing in the direction of airflow.



Troubleshooting

This section is intended to be used as a diagnostic aid only. For detailed repair procedures, contact your local Trane service representative.

⚠ WARNING
<p>Hazardous Service Procedures!</p> <p>Failure to follow all precautions in this manual and on the tags, stickers, and labels could result in death or serious injury.</p> <p>Technicians, in order to protect themselves from potential electrical, mechanical, and chemical hazards, MUST follow precautions in this manual and on the tags, stickers, and labels, as well as the following instructions: Unless specified otherwise, disconnect all electrical power including remote disconnect and discharge all energy storing devices such as capacitors before servicing. Follow proper lockout/tagout procedures to ensure the power can not be inadvertently energized. When necessary to work with live electrical components, have a qualified licensed electrician or other individual who has been trained in handling live electrical components perform these tasks.</p>

Table 6. Air handler troubleshooting recommendations

Symptom	Probable Cause	Recommended Action
Motor Fails to Start	Blown fuse or open circuit breaker	Replace fuse or reset circuit breaker.
	Overload trip	Check and reset overload.
	Improper wiring or connections	Check wiring with diagram supplied on unit.
	Improper current supply	Compare actual supply power with motor nameplate recommendations. Contact power company for adjustments.
	Mechanical failure	Check that the fan motor rotates freely.
Motor Stalls	Open phase	Check line for an open phase.
	Overloaded motor	Reduce the load or replace with a larger motor.
	Low line voltage	Check across AC line. Correct voltage if possible.
Excessive Vibration	Fan out of balance	Rebalance the fan.
	Motor mounting bolts are loose	Check the fan assembly connections.
Motor Runs and Then Dies Down	Partial loss of line voltage	Check for loose connections. Determine adequacy of main power supply.
Motor Does not Come Upto Speed	Low voltage at motor terminals	Check across AC line and correct voltage loss if possible.
	Line wiring to motor too small	Replace with larger sized wiring.
Motor Overheats	Overloaded motor	Reduce load or replace with a larger motor.
Excessive Motor Noise	Motor mounting bolts loose	Tighten motor mounting bolts.
	Worn motor bearings	Replace the fan assembly.
	Fan rubbing on fan cover	Remove interference in motor fan housing.

Troubleshooting

Table 6. Air handler troubleshooting recommendations (continued)

Symptom	Probable Cause	Recommended Action
Low Water Coil Capacity	Incorrect airflow	Check fan operating condition.
	Incorrect water flow	Inspect the water pumps and valves for proper operation and check the lines for obstructions.
	Incorrect water temperature	Adjust the chiller or boiler to provide the proper water temperature.
	Coil is piped incorrectly	Verify coil piping (see "Piping and Connections," p. 18).
	Dirty fin surface	Clean the fin surface (see "Coils," p. 32).
	Incorrect glycol mixture	Verify glycol mixture and adjust if necessary.
Drain Pan is Overflowing	Plugged Drain Line	Clean drain line.
	Unit not level	Level unit.
	Improper trap design	Design trap per unit installation instructions.
Standing Water in Drain Pan	Improper trap design	Design trap per unit installation instructions.
	Unit not level	Level unit.
	Plugged drain line	Clean drain line.
Wet Interior	Coil face velocity too high	Reduce fan speed.
	Improper trap design	Design trap per unit installation instructions.
	Drain pan leaks/overflows	Repair leaks.
	Condensation on surfaces	Insulate surfaces.
Excess Dirt in Unit	Missing filters	Replace filters.
	Filter bypass	Reduce filter bypass by ensuring all blockoffs are in place.
Microbial Growth (Mold) Inside Air Handler	Standing water in drain pan	See Standing water in drain pan above.



Notes

Trane - by Trane Technologies (NYSE: TT), a global innovator - creates comfortable, energy efficient indoor environments for commercial and residential applications. For more information, please visit trane.com or tranetechnologies.com.

Trane has a policy of continuous product and product data improvements and reserves the right to change design and specifications without notice. We are committed to using environmentally conscious print practices.

CLCH-SVX015B-EN 09 Feb 2025
Supersedes CLCH-SVX015A-EN (March 2024)

©2025 Trane