



Installation, Operation, and Maintenance

# Gas Heat – Inshot Style Performance Climate Changer™ CSAA Air Handlers

Sizes 4 to 30 for Indoor and Outdoor Units



## SAFETY WARNING

Only qualified personnel should install and service the equipment. The installation, starting up, and servicing of heating, ventilating, and air-conditioning equipment can be hazardous and requires specific knowledge and training. Improperly installed, adjusted or altered equipment by an unqualified person could result in death or serious injury. When working on the equipment, observe all precautions in the literature and on the tags, stickers, and labels that are attached to the equipment.



# Introduction

Read this manual thoroughly before operating or servicing this unit.

## Warnings, Cautions, and Notices

Safety advisories appear throughout this manual as required. Your personal safety and the proper operation of this machine depend upon the strict observance of these precautions.

The three types of advisories are defined as follows:

**⚠ WARNING** Indicates a potentially hazardous situation which, if not avoided, could result in death or serious injury.

**⚠ CAUTION** Indicates a potentially hazardous situation which, if not avoided, could result in minor or moderate injury. It could also be used to alert against unsafe practices.

**NOTICE** Indicates a situation that could result in equipment or property-damage only accidents.

## Important Environmental Concerns

Scientific research has shown that certain man-made chemicals can affect the earth's naturally occurring stratospheric ozone layer when released to the atmosphere. In particular, several of the identified chemicals that may affect the ozone layer are refrigerants that contain Chlorine, Fluorine and Carbon (CFCs) and those containing Hydrogen, Chlorine, Fluorine and Carbon (HCFCs). Not all refrigerants containing these compounds have the same potential impact to the environment. Trane advocates the responsible handling of all refrigerants-including industry replacements for CFCs and HCFCs such as saturated or unsaturated HFCs and HCFCs.

## Important Responsible Refrigerant Practices

Trane believes that responsible refrigerant practices are important to the environment, our customers, and the air conditioning industry. All technicians who handle refrigerants must be certified according to local rules. For the USA, the Federal Clean Air Act (Section 608) sets forth the requirements for handling, reclaiming, recovering and recycling of certain refrigerants and the equipment that is used in these service procedures. In addition, some states or municipalities may have additional requirements that must also be adhered to for responsible management of refrigerants. Know the applicable laws and follow them.

### ⚠ WARNING

#### Proper Field Wiring and Grounding Required!

Failure to follow code could result in death or serious injury. All field wiring **MUST** be performed by qualified personnel. Improperly installed and grounded field wiring poses **FIRE** and **ELECTROCUTION** hazards. To avoid these hazards, you **MUST** follow requirements for field wiring installation and grounding as described in **NEC** and your local/state/national electrical codes.

### ⚠ WARNING

#### Personal Protective Equipment (PPE) Required!

Failure to wear proper PPE for the job being undertaken could result in death or serious injury. Technicians, in order to protect themselves from potential electrical, mechanical, and chemical hazards, **MUST** follow precautions in this manual and on the tags, stickers, and labels, as well as the instructions below:

- Before installing/servicing this unit, technicians **MUST** put on all PPE required for the work being undertaken (Examples; cut resistant gloves/sleeves, butyl gloves, safety glasses, hard hat/bump cap, fall protection, electrical PPE and arc flash clothing). **ALWAYS** refer to appropriate Safety Data Sheets (SDS) and OSHA guidelines for proper PPE.
- When working with or around hazardous chemicals, **ALWAYS** refer to the appropriate SDS and OSHA/GHS (Global Harmonized System of Classification and Labeling of Chemicals) guidelines for information on allowable personal exposure levels, proper respiratory protection and handling instructions.
- If there is a risk of energized electrical contact, arc, or flash, technicians **MUST** put on all PPE in accordance with OSHA, NFPA 70E, or other country-specific requirements for arc flash protection, **PRIOR** to servicing the unit. **NEVER PERFORM ANY SWITCHING, DISCONNECTING, OR VOLTAGE TESTING WITHOUT PROPER ELECTRICAL PPE AND ARC FLASH CLOTHING. ENSURE ELECTRICAL METERS AND EQUIPMENT ARE PROPERLY RATED FOR INTENDED VOLTAGE.**

**⚠ WARNING****Follow EHS Policies!**

Failure to follow instructions below could result in death or serious injury.

- All Trane personnel must follow the company's Environmental, Health and Safety (EHS) policies when performing work such as hot work, electrical, fall protection, lockout/tagout, refrigerant handling, etc. Where local regulations are more stringent than these policies, those regulations supersede these policies.
- Non-Trane personnel should always follow local regulations.

## Copyright

This document and the information in it are the property of Trane, and may not be used or reproduced in whole or in part without written permission. Trane reserves the right to revise this publication at any time, and to make changes to its content without obligation to notify any person of such revision or change.

## Trademarks

All trademarks referenced in this document are the trademarks of their respective owners.

## Revision History

- Updated Installation chapter.
- Updated Wiring Diagrams chapter.
- Updated Troubleshooting Guide chapter.



# Table of Contents

General Information	5	Heat Exchanger Condensate Piping	18
Overview of Manual	5	Wiring	19
Nameplate	5	Wiring Checklist	19
Product Information	6	High-Voltage Wiring	19
Burner Specifications	6	Wiring Entrance Locations	19
Description	7	Low-Voltage Wiring	20
Pre-Installation	8	Start-Up — Indirect Gas-Fired Heating	21
Receiving and Handling	8	Gas Heat Application Rules — Inshot	21
Inspection	8	Start-up Procedure	21
Packaging/Shipping	8	Safety Controls	24
Handling	8	Normal Sequence of Operation	24
Receiving Checklist	8	Normal Shutdown	25
Jobsite Storage	9	Wiring Diagrams	26
Outdoor Storage	9	Routine Maintenance	29
Dimensions and Weights	10	Troubleshooting Guide	30
Service Clearances	10	VB1285 BPP Split Manifold Modulating Control	30
Installation	12	VB1285 Sequence of Operations	30
Contractors' Responsibilities	12	VB1287 Sequence of Operations	33
Installing Contractor	12		
Electrical and/or Controls Contractor	12		
Lifting and Rigging	13		
Placement and Assembly	13		
Flue Stack for Outdoor Air Handlers	13		
Installation	13		
High Altitude Installations	13		
Installing Outdoor Flue Stacks	13		
Installing Indoor Flue Stacks	14		
Installing Rain Hood/Combustion Air Inlet	14		
Installing Flue Stack for Hurricane Applications	14		
Duct Connections	14		
Combustion Air Duct	14		
Duct Transitions	15		
Airflow Direction	15		
Opening and Piping Locations	16		
Piping	18		
Gas Piping	18		
Proper Gas Pressure	18		



# General Information

## Overview of Manual

Use this manual to install, startup, operate, and maintain the Performance Climate Changer™ air handler gas heat

section. Carefully review the procedures discussed in this manual to minimize installation and startup difficulties.

## Nameplate

Each air handler section includes a nameplate/label which identifies the type of section, customer tagging information, the unit serial number, the unit order number, the build-section position for installation, and the unit model number.

**Note:** The unit serial number and order number is required when ordering parts or requesting service for a Trane air handler.

Figure 1. Example - Performance air handler section nameplate

### Performance Climate Changer™ Air Handler

<b>Order No.</b>	A5K703A B/M A
<b>Serial No.</b>	K01K12345
<b>Unit Model No.</b>	CSAA006UAC00
<b>Tag ID</b>	AHU-1
<b>Build Section</b>	2 of 2



#### GAS HEATSECTION

NATURAL GAS	MAX	MIN
INPUT – MBH/HR	375	125
OUTPUT – MBH/HR	300	100
GAS INLET PRESS – IN. W.C.	14	7
MANIFOLD PRESS – IN. W.C.	3.7	0.41
TEMPERATURE RISE – F	91	30
EXT STATIC PRESS – IN. W.C.	2.5	

INPUT V/HZ/PH	115/60/3	MCA	11.4	MOP	15.0
BURNER V/HZ/PH	120/60/1	FLA	4.3	HP	0.25
CONT CKT V/HZ/PH	120/60/1	A	6.0		

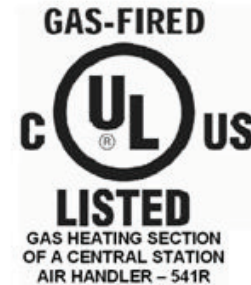

#### CLEARANCES TO COMPBUSTIBLE MATERIAL:

FLUE:	6 inches
CABINET:	0 inches
DUCT:	2 inches for 3 feet; 0 inches thereafter

Manufactured under one or more of the following patent numbers:  
5396782, 5674125, 6237354, 6973795, 7017356, 7150314, 7178355, 7340906, 7389646, 7526903, 7685834,

Trane

www.trane.com

Made in USA



## General Information

### Product Information

Model and serial numbers for the gas heat section are designated on the nameplate located on the piping-side access door inside the section. Record the information below for a permanent record of the equipment installed on your job site. The nameplate also contains the range of settings for which the gas heat unit is capable. Record and

retain these settings in case the unit should ever need adjustment after service repairs.

**Note:** This information is required when ordering repair parts.

Model Number_____
Serial Number_____
Air Handler Sales Order Number_____
Air Handler Serial Number_____
Startup Date_____
Altitude Above Sea Level_____
Calorific Value_____

### Burner Specifications

Maximum Firing MBh_____
Minimum Firing MBh_____
Type of Gas_____
Maximum Inlet Gas Pressure_____
Minimum Inlet Gas Pressure_____
Temperature Rise (°F)_____
Manifold Pressure at Maximum MBh_____

**Table 1. Motor and electrical specifications**

Specifications	Gas Heater Input Power	Inducer Motor <sup>(a)</sup>	Control Power <sup>(a)</sup>
Volts		115	115
Hertz	60	60	60
Phase		1	1
HP	n/a		n/a
FLA/Amps	n/a		6

(a) Powered by a "line to 115 volt" transformer for all gas heaters except 115/60/1 rated units.

## **Description**

The gas heat section consists of an inshot tubular heat exchanger gas train components, and a control panel for electrical connections. It is an integral part of the entire air-handling system.

An access door is provided for service and maintenance of the burner and gas train components.

The gas heat section must be in a blow-thru position downstream from the supply fan. Downstream sections must be separated by a blank access section and discharge temperatures must be controlled so as not to exceed the temperature limits of components in the downstream sections.



# Pre-Installation

## Receiving and Handling

### Inspection

Upon delivery, thoroughly inspect all components for any shipping damage that may have occurred, and confirm that the shipment is complete. See “Receiving Checklist” for detailed instructions.

**Note:** *Delivery cannot be refused. All units are shipped F.O.B. factory. Trane is not responsible for shipping damage.*

### Packaging/Shipping

Gas heat sections arrive at the jobsite with an integral base frame for the purpose of mounting units to a housekeeping pad or roof curb. The base frame variables in height from the standard 2.5-inches to 8-inches.

Outdoor gas heat sections ship with wooden blocks fastened under the base channel. The blocks elevate the section for shipping protection and ease of handling. Leave the wooden blocks attached until the section is placed in its final position to avoid bending the base channel during rigging and handling.

### Protective Covering

The large openings of the gas heat section are covered with shipping protection parts. The parts are held in place by sheet metal screws. Leave the covering attached to the section until it is ready to install to prevent debris from entering the section.

### Flue Stack

A stainless-steel flue stack is provided with outdoor air handlers. It ships inside the gas heat section or in one of the other sections of the air handler, and must be mounted on the flue opening on the side of the unit.

### NOTICE

#### Equipment Damage!

**Failure to follow this instruction could result in equipment damage. Do not use type B flue stacks with this product as they are not suitable for the flue gas temperatures.**

### Hardware Kits

Hardware kits ship inside the air handler fan section in a plastic bag or cardboard box. This kit contains gasketing and screws. For outdoor units, roof joint connection strips and wall panel seam caps are included. These are used when fastening the gas heat section to the air handler. Keep the hardware with the gas heat section until it is ready to install.

### Rain Hood

A rain hood is provided for outdoor units and is shipped attached. Rain hoods for units with hurricane certifications are shipped on a separate wood skid. A kit containing mounting hardware ships inside the gas heat section and must be removed before assembly to the air handler.

### Instruction Manuals

Individual instruction manuals for all of the gas train components (such as flame-control relay valves, pressure switches, and actuators) ship inside the piping vestibule. Retain these manual for future repair or troubleshooting.

### Handling

The gas heat section is designed with the necessary number of lift points for safe installation. The lift points are designed to accept standard rigging devices and are removable after installation.

Indoor sections size 4 to 30 will be shipped with a shipping skid designed for forklift transport. If shipped on a skid, do not remove the gas heat section from the skid at this time.

### Receiving Checklist

Complete the following checklist immediately after receiving shipment to detect possible shipping damage.

- Check to ensure that the shipment is complete. Small components may ship inside the unit or ship separately. Check the parts list to ensure all materials are present. If any component is missing, contact your local Trane sales office.
- Check all units, components, connections, and piping. Check all doors, latches and hinges. Inspect interior of each unit or section. Check for rattles, bent corners, or other visible indications of shipping damage.
- If a unit is damaged, make specific notations concerning the damage on the freight bill. Do not refuse delivery.
- Notify the carrier’s terminal of the damage immediately by phone and mail. Request an immediate joint inspection of the damage by the carrier and consignee.
- Notify your Trane sales representative of the damage and arrange for repair. Do not attempt to repair the unit without consulting the Trane representative.
- Inspect the unit for concealed damage as soon as possible after delivery. Report concealed damage to the freight line. It is the receiver’s responsibility to provide reasonable evidence that concealed damage did not occur after delivery. Take photos of damaged material if possible.

**Note:** *Concealed damage must be reported within 15 days of receipt.*



## Jobsite Storage

Indoor air handlers and field-installed accessories must be protected from the elements. A controlled indoor environment is recommended for proper storage.

**Note:** *All factory shipping protection should be removed, This wrapping is for transit protection only.*

The unit controller and all other electrical/electronic components should be stored in conditions of -20°F to 120°F and 5 to 95 percent relative humidity, non-condensing. Electrical components are not moisture-tolerant.

Gas heat sections for outdoor units require no special protection for storage prior to installation.

## Outdoor Storage

### **NOTICE**

#### **Corrosion!**

**Plastic tarps can cause condensation to form in and on the equipment, which could result in corrosion damage or wet storage stains. Use only canvas tarps to cover air handlers and components.**

Outdoor storage is **not** recommended for units that will be installed indoors. However, when outdoor storage is necessary, several things must be done to prevent damage:

**Note:** *Keep the equipment on the original wooden blocks/skid for protection and ease of handling.*

- Select a well-drained area, preferably a concrete pad or blacktop surface.
- Place the unit on a dry surface or raised off the ground to assure adequate air circulation beneath the unit and to assure no portion of the unit will contact standing water at any time.
- Cover the unit securely with a canvas tarp.
- Do not stack units.
- Do not pile other material on the unit.

*Trane warranty does not cover equipment damage due to negligence during storage.*



# Dimensions and Weights

## Service Clearances

A minimum clearance of the section width plus 12 inches on the access door side of the gas heat section is recommended for routine maintenance. This clearance provides enough room to replace the heat exchanger in the event of failure. The section side panels must be removed to access the heat exchanger. Refer to the following figure for service clearance recommendations for the air handler.

**Note:** At a minimum, the clearance dimensions listed in table below are recommended on one side of the unit for regular service and maintenance. Refer to

*as-built submittal for locations of items such as filter access doors, coil, piping connections, motor locations, hoods, pipe cabinets, etc. Sufficient clearance must be provided on all sides of unit for removal of access panels, plug panels, or section-to-section attachment brackets. Clearance for starters, VFDs, or other high-voltage devices must be provided per NEC requirements. For specific dimensional and weight information, refer to the unit submittals. The dimensions and weights in this manual are approximate. Trane has a policy of continuous product and product data improvement and reserves the right to change design and specifications without notice.*

Figure 2. Service clearance for indoor units

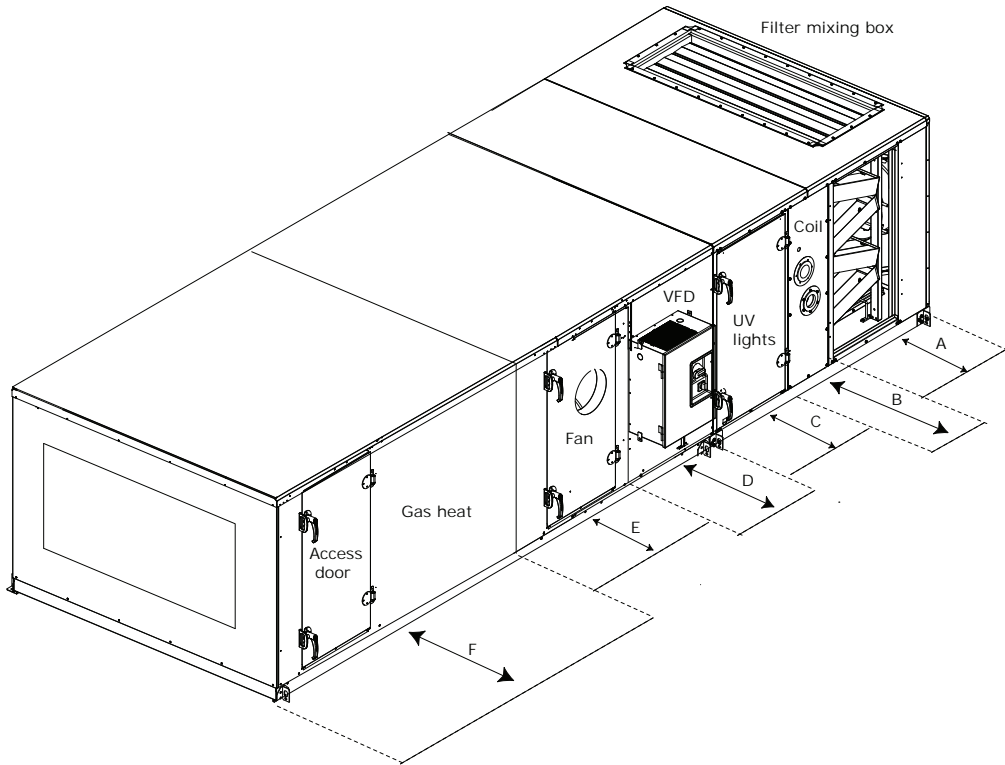

Table 2. Service clearance dimensions (in.)

Component	Description	4	6	8	10	12	14	17	21	25	30
F	Gas Heat	n/a	56	63	74	79	84	84	92	92	106

**Table 3. Dimensions and weights**

Unit Size	Output Capacity (MBh)	Length (in.)	Weight (lb)
004	95	41.136	432
	205	56.636	625
006	95	41.136	441
	205	56.636	636
	325	74.136	856
008	205	56.636	691
	325	74.136	919
	405	84.136	1027
010	205	56.636	733
	325	74.136	970
	405	84.136	1068
012	240	44.386	639
	325	57.386	854
	485	67.136	997
014	240	44.386	657
	325	57.386	875
	485	67.136	1021
017	240	44.386	686
	325	57.386	910
	485	67.136	1060
021	650	66.006	1348
	970	81.006	1646
025	650	66.006	1391
	970	81.006	1695
030	650	66.006	1453
	970	81.006	1767



# Installation

## ⚠ WARNING

### Improper Unit Lift!

Failure to properly lift unit in a LEVEL position could result in unit dropping and possibly crushing operator/technician which could result in death or serious injury, and equipment or property-only damage. Test lift unit approximately 24 inches (61 cm) to verify proper center of gravity lift point. To avoid dropping of unit, reposition lifting point if unit is not level.

## ⚠ WARNING

### Heavy Objects!

Failure to follow instructions above or properly lift unit could result in unit dropping and possibly crushing operator/technician which could result in death or serious injury. Ensure that all the lifting equipment used is properly rated for the weight of the unit being lifted. Each of the cables (chains or slings), hooks, and shackles used to lift the unit must be capable of supporting the entire weight of the unit. Lifting cables (chains or slings) may not be of the same length. Adjust as necessary for even unit lift. Other lifting arrangements could cause equipment or property damage.

## ⚠ WARNING

### Hazardous Gases and Flammable Vapors!

Failure to follow all instructions could result in death or serious injury. Exposure to hazardous gases from fuel substances have been shown to cause cancer, birth defects or other reproductive harm. Improper installation, adjustment, alteration, service or use of this product could cause flammable mixtures or lead to excessive carbon monoxide. To avoid hazardous gases and flammable vapors follow proper installation and set up of this product and all warnings as provided in this manual.

## ⚠ WARNING

### Combustible Materials!

Failure to maintain proper clearances could result in death or serious injury or property damage. Maintain proper clearance between the unit heat exchanger, vent surfaces and combustible materials. Refer to unit nameplate and installation instructions for proper clearances. Improper clearances could result in combustible materials catching on fire.

## Contractors' Responsibilities

### Installing Contractor

- Unpack the gas heat section and remove the skid.

- Remove protective coverings.
- Rig and/or move the section to the air handler location. The contractor must provide slings, spreader bars, clevis hooks, pins, etc. for rigging.
- For outdoor gas heat sections, a level roof curb or structural steel support system is required.
- For outdoor sections, install the flue stack. The flue must be removed from the airstream before assembly. Install the flue stack on the gas heat section *before* assembling the gas heat section to the air handler.
- Clear debris from combustion air inlets located on the side or bottom of the gas heat section. Remove any debris obstructing combustion air inlets.
- In areas where snow drifts are higher than the bottom of the vestibule, a hood or louver may have to be installed for combustion air.
- Assemble the gas heat section to the air-handling system. Refer to *CLCH-SVX07\*-EN Performance Climate Changer™ Air Handler Installation, Operation, and Maintenance* manual for specific assembly instructions. This manual ships inside the supply fan section of the air handler.
- Penetrate the unit casing and connect the supply gas line to the gas train.
- For indoor gas heat sections, install a field-engineered flue stack according to local codes.

### Electrical and/or Controls Contractor

- Provide power to the gas heat section. See Wiring chapter for power requirements.
- For field-provided control systems, the binary start-stop to the 2K50 Molex connector must be a dry set of binary contacts.
- Provide an analog 2 to 10 Vdc modulating signal. A 2 to 10 Vdc interface module is installed as standard equipment.
- Provide an interlock in the start-stop signal circuit with the air handler supply fan. This interlock must insure the start-stop signal is interrupted to the gas heat system if the supply fan is shut off. The gas heat system must not operate without the supply fan providing airflow.
- All wiring must comply with applicable local and National Electric Code (NEC) specifications.
- For VAV units, provide temperature sensors for entering and leaving air in gas heat section.

**Note:** All power and control wiring for the gas heat section must be field-provided. All power and control wiring for any section downstream of the gas heat must be field-provided.

## Lifting and Rigging

Refer to *CLCH-SVX07\*-EN Performance Climate Changer™ Air Handler Installation, Operation, and Maintenance* manual for instructions on equipment rigging and lifting. This manual ships inside the unit fan section.

## Placement and Assembly

Refer to the design engineer's plans and submittals for the location of the gas heat section in the air handler. The gas heat section will arrive at the job site as an individual section. It is not shipped with the air handler.

Hardware for fastening the gas heat section to the air handler can be found in the unit fan section.

Final assembly of the air handler should be done at the unit installation site. Refer to *CLCH-SVX07\*-EN Performance Climate Changer™ Air Handler Installation, Operation, and Maintenance* manual for instructions on equipment assembly.

### Flue Stack for Outdoor Air Handlers

The flue stack for outdoor air handlers must be mounted on the flue opening on the side of the unit. The flue stack must be installed on the gas heat section *before* assembling the gas heat section to the air handler. It is very difficult to remove the flue from inside the unit once the unit is assembled.

## Installation

### High Altitude Installations

#### **⚠ WARNING**

#### **Hazard of Explosion!**

Failure to follow these instructions could result in death or serious injury or equipment or property-only damage. Installations at altitudes of 3,000 feet above sea level or higher may require adjustment of the air-fuel linkage for proper combustion. Air-fuel adjustment should only be done by an experienced, qualified gas heat technician.

Air-fuel adjustment is not normally required. However, for high altitude installations, adjustment to the air-fuel may be necessary for proper combustion. Heater outputs must be derated four percent for every 1000 feet over 2000 feet above sea level. When specifying gas heaters, the engineer should provide the MBh and airflow required at altitude. All Trane literature is based on nominal outputs at sea level.

It is recommended that the services of an experienced, qualified gas heat technician be employed to adjust air-fuel ratios for proper combustion.

### Installing Outdoor Flue Stacks

The flue stack for outdoor gas heat sections ships inside the gas heat section or in one of the other sections of the air handler.

**Figure 3. Outdoor air handler flue stack**

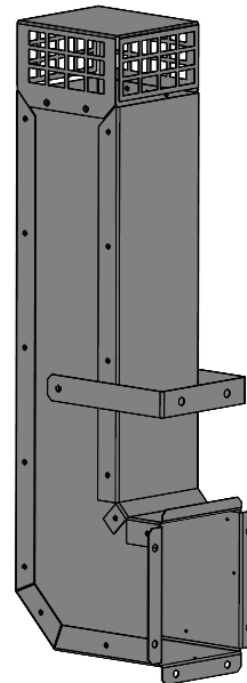

Attach the flue stack to the flue collar and secure it with screws as indicated in the following figure.

A field-provided rain hood or screen is recommended on the flue to prevent possible blockage from bird nests and beehives.

**Figure 4. Flue stack installation for outdoor applications**

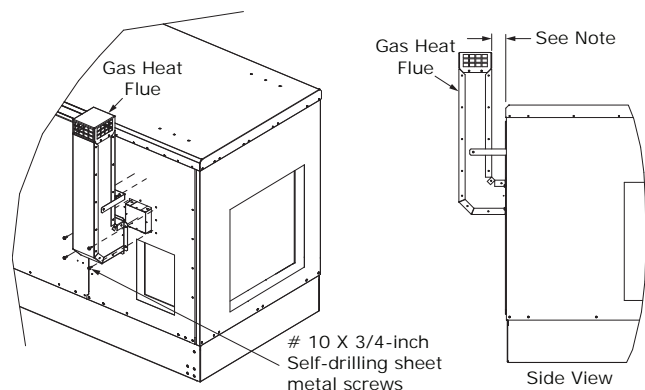

**Note:** When installing flue, leave enough clearance to avoid roof's edge and anything above the roof.

### Installing Indoor Flue Stacks

Gas heat sections for indoor air handlers require a field-engineered and field-installed flue stack. Local codes and practices vary throughout the country. The engineer should size the flue based on MBh output, horizontal and vertical run lengths, type of flue material, NFPA 54 Fuel Gas Code, and local codes. The flue should be designed for 550° F (288° C). If horizontal runs over 20 feet or other static-increasing transitions are necessary, a flue booster fan will be required.

Install according to local codes.

**Table 4. Flue connection sizes for gas heat sections**

Output Capacity (MBh)	Flue Size (in.)
95	3.2 x 3.2
205, 240, 325, 405, 485, 625, 970	4.6 x 4.6

### Installing Rain Hood/Combustion Air Inlet

Rain hoods are only required on an outdoor unit with an internal vestibule. The combustion air opening will be in the side panel.

Rain hoods for the combustion air opening ship attached to the side panel or ship loose and must be installed at the job site. The assembly consists of the hood, butyl tape, and number 10 screws.

- Install butyl tape between the hood and the side panel or door panel. See the following figure.

**Figure 5. Installation of rain hood for combustion air opening**

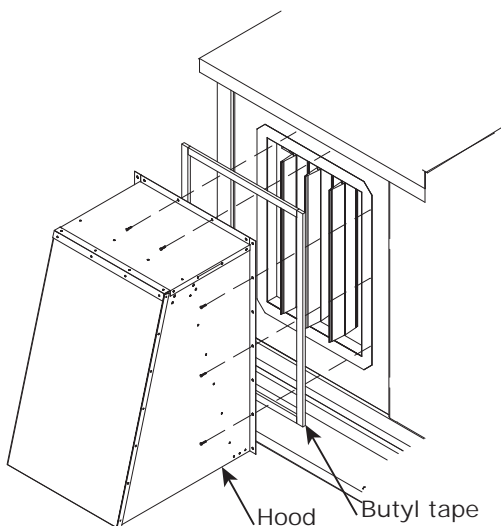

- Locate the bottom edge of the hood 2 3/8 inches below the bottom edge of the inlet air opening and center the hood left-to-right over the inlet air opening. See the following figure.
- Install the hood to the unit with number 10 screws.

**Figure 6. Center inlet air opening**

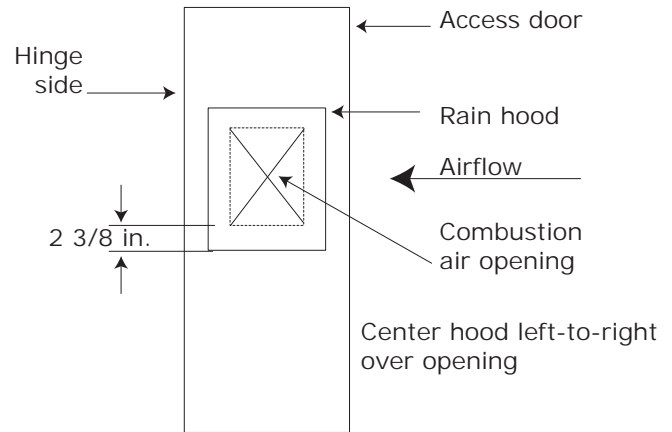

### Installing Flue Stack for Hurricane Applications

**Figure 7. Flue stack installation for hurricane applications**

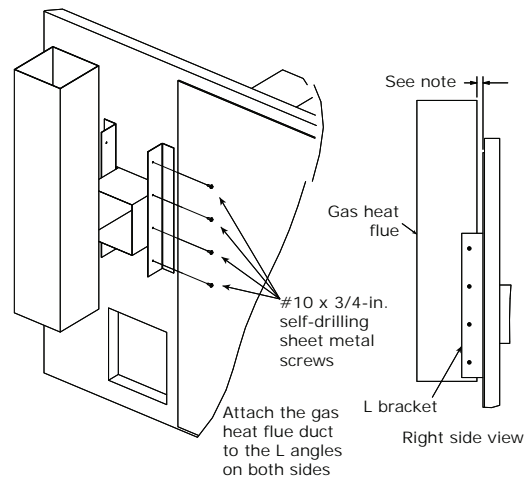

**Note:** When installing flue, leave enough clearance to avoid roof's edge and anything above the roof.

### Duct Connections

All duct connections to the gas heat section should be installed in accordance with the standards of the National Fire Protection Association (NFPA) and the Sheet Metal and Air Conditioning Contractors National Association, Inc. (SMACNA).

### Combustion Air Duct

- Outdoor units have a rain hood that either ships attached to the side panel or ships loose and requires field mounting.
- All indoor units ship with a screened opening on the combustion air inlet.

If combustion air is ducted to the gas heat vestibule the unit's capacity must be derated to account for air resistance in the duct. For every 0.14 inches wg of duct resistance, unit capacity (MBh output) will reduce by five percent.

If combustion air is ducted to the vestibule, it is strongly recommended that an experienced gas heat technician check the system and emission levels in the exhaust flue at start up. Carbon dioxide should be between 7.0 and 9.0 percent. This corresponds to the allowable range of excess air needed for combustion. The additional static pressure of the inlet air duct may change the fuel-air ratio slightly necessitating system adjustment.

Combustion air must be ducted directly to the casing opening. The airflow through the vestibule is needed to keep the temperatures in the vestibule down.

## Duct Transitions

When the gas heat section is the last section of the air handler, and duct transitions should be smooth and uniform from all sides. When a discharge plenum is not selected, a minimum of 3 duct diameters of straight duct leaving the air handler discharge is recommended. Follow recommendations for duct transitions from SMACNA.

Fasten the ductwork directly to the ductwork opening. When using lined ductwork, the insulation should not obstruct the discharge opening.

## Airflow Direction

The airflow direction through the gas heater is important because it prevents localized "hot spots" on the heat exchanger. Airflow direction labels denoting correct airflow direction through the gas heat section are provided on the burner side of the heating section. See the following figure.

**Figure 8. Airflow direction label**

**Performance Climate Changer™ Air Handler**

Order No.	ASK703A B/M A		
Serial No.	K01K12345		
Unit Model No.	CSAA006UAC00		
Tag ID	AHU-1		
Build Section	2 of 2		



**GAS HEATSECTION**

NATURAL GAS	MAX	MIN		
INPUT – MBH/HR	375	125		
OUTPUT – MBH/HR	300	100		
GAS INLET PRESS – IN. W.C.	14	7		
MANIFOLD PRESS – IN. W.C.	3.7	0.41		
TEMPERATURE RISE – F	91	30		
EXT STATIC PRESS – IN. W.C.	2.5			

INPUT V/HZ/PH	115/60/3	MCA	11.4	MOP	15.0
BURNER V/HZ/PH	120/60/1	FLA	4.3	HP	0.25
CONT CKT V/HZ/PH	120/60/1	A	6.0		



**CLEARANCES TO COMBUSTIBLE MATERIAL:**  
 FLUE: 6 inches  
 CABINET: 0 inches  
 DUCT: 2 inches for 3 feet; 0 inches thereafter

Manufactured under one or more of the following patent numbers:  
 5396782, 5674125, 6237354, 6973795, 7017356, 7150314, 7178355, 7340906, 7389646, 7526903, 7685834,

Trane

www.trane.com

Made in USA

## Opening and Piping Locations

Figure 9. Size 4-17 opening and piping locations

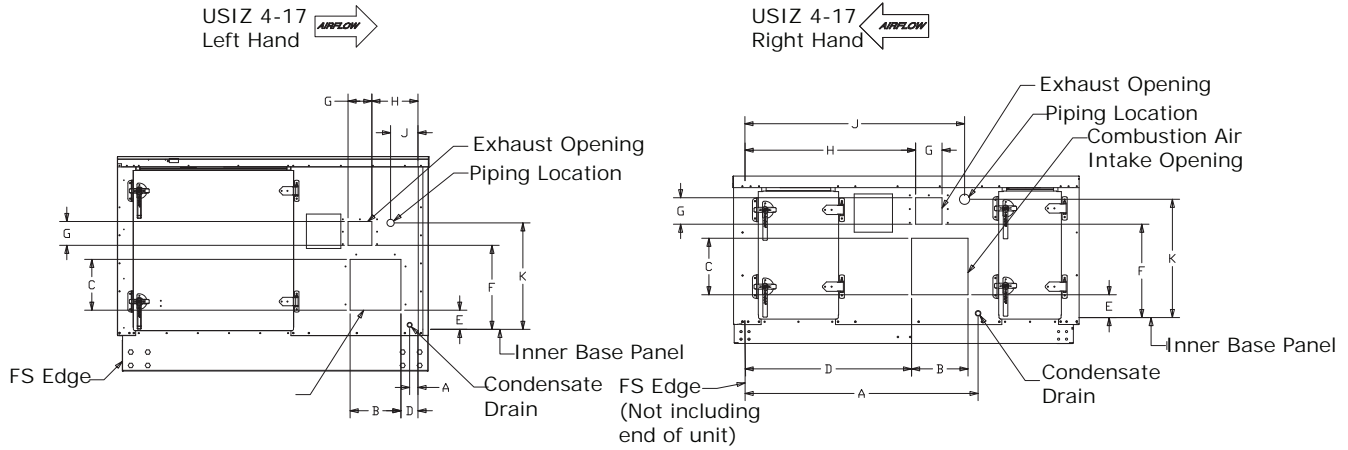
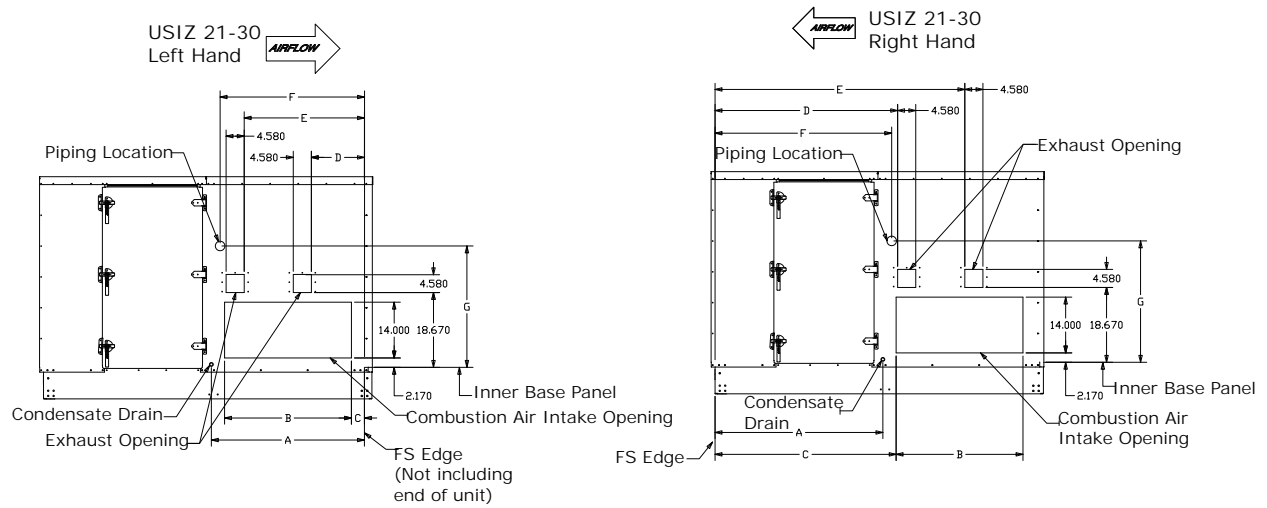

Table 5. Size 4-17 opening and piping locations

USIZ	CAPY	A		B	C	D		E	F	G	H		J(a)		K(a)
		LH	RH			LH	RH				LH	RH	LH	RH	
4	95	4.1	23.1	6.1	6.1	3.1	15.5	7.0	15.6	3.2	2.9	21.1	9.8	17.5	2.4
4	205	4.6	38.1	9.7	9.7	3.1	28.7	3.7	15.9	4.6	8.9	29.3	4.8	38.0	20.4
6	95	4.1	23.1	6.1	6.1	3.1	15.5	7.0	15.6	3.2	2.9	21.1	9.8	17.5	2.4
6	205	4.6	38.1	9.7	9.7	3.1	28.7	3.7	15.9	4.6	8.9	29.3	4.8	38.0	20.4
6	325	27.1	33.1	12.2	12.2	3.1	42.9	1.2	15.9	4.6	17.6	38.1	22.8	37.2	3.0
8	205	4.6	38.1	9.7	9.7	3.1	26.7	3.7	15.9	4.6	8.9	29.3	4.8	38.0	20.4
8	325	27.1	58.1	12.2	12.2	3.1	42.9	1.2	15.9	4.6	17.6	38.1	23.0	37.2	3.0
8	405	24.1	46.1	17.0	11.0	3.1	50.2	2.4	15.9	4.6	24.6	41.1	34.5	35.8	9.1
10	205	4.6	38.1	9.7	9.7	3.1	28.7	3.7	15.9	4.6	8.9	29.3	4.8	38.0	20.4
10	325	19.1	41.1	12.2	12.2	3.1	44.9	1.2	15.9	4.6	17.6	38.1	23.0	37.2	3.0
10	405	24.1	46.1	17.0	11.0	3.1	50.2	2.4	15.9	4.6	24.6	41.1	34.5	35.8	9.1
12	240	4.6	25.9	9.7	9.7	3.1	17.7	9.5	21.6	4.6	4.8	21.2	11.1	19.4	5.0
12	325	4.6	38.9	12.2	12.2	3.1	28.2	6.9	21.6	4.6	9.8	29.2	15.0	28.5	3.4
12	485	4.6	48.6	15.0	15.0	3.1	33.7	4.2	21.6	4.6	13.1	35.6	6.1	47.1	24.3
14	240	4.6	25.9	9.7	9.7	3.1	17.7	9.5	21.6	4.6	4.8	21.2	11.1	19.4	5.0
14	325	4.6	38.9	12.2	12.2	3.1	28.2	6.9	21.6	4.6	9.8	29.2	15.0	28.5	3.4
14	485	4.6	48.6	15.0	15.0	3.1	33.7	4.2	21.6	4.6	13.1	35.6	6.1	47.1	24.3
17	240	4.6	25.9	9.7	9.7	3.1	17.7	9.5	21.6	4.6	4.8	21.2	11.1	19.4	5.0
17	325	4.6	38.9	12.2	12.2	3.1	28.2	6.9	21.6	4.6	9.8	29.2	15.0	28.5	3.4
17	485	4.6	48.6	15.0	15.0	3.1	35.2	4.2	21.6	4.6	13.1	35.6	6.1	47.1	24.3

(a) Gas supply line requires field cut penetration through AHU casing.



**Figure 10. Size 21-30 opening and piping locations**

**Table 6. Size 21-30 opening and piping locations**

USIZ	CAPY	A		B	C		D		E		F		G
		LH	RH		LH	RH	LH	RH	LH	RH	LH	RH	
21	625	28.1	24.0	21.3	3.1	27.7	4.5	25.1	22.5	43.1	12.1	40.1	30.6
21	970	38.5	28.6	32.0	3.1	32.0	13.4	32.1	30.4	49.1	37.0	30.2	30.4
25	625	28.1	24.0	21.3	3.1	27.7	4.5	25.1	22.5	43.1	12.1	40.1	30.6
25	970	38.5	28.6	32.0	3.1	32.0	13.4	32.1	30.4	49.1	37.0	30.2	30.4
30	625	28.1	24.0	21.3	3.1	27.7	4.5	25.1	22.5	43.1	12.1	40.1	30.6
30	970	38.5	28.6	32.0	3.1	32.0	13.4	32.1	30.4	49.1	37.0	30.2	30.4

**Note:** Gas supply line requires field cut penetration through AHU casing.



# Piping

## ⚠ WARNING

### Hazard of Explosion and Deadly Gases!

Failure to follow all proper safe refrigerant handling practices could result in death or serious injury. Never solder, braze or weld on refrigerant lines or any unit components that are above atmospheric pressure or where refrigerant may be present. Always remove refrigerant by following the guidelines established by the EPA Federal Clean Air Act or other state or local codes as appropriate. After refrigerant removal, use dry nitrogen to bring system back to atmospheric pressure before opening system for repairs. Mixtures of refrigerants and air under pressure may become combustible in the presence of an ignition source leading to an explosion. Excessive heat from soldering, brazing or welding with refrigerant vapors present can form highly toxic gases and extremely corrosive acids.

## Gas Piping

**Note:** Installation must conform with the American National Standard Z223.1 (NFPA 54), the National Fuel Gas Code, latest edition, in the absence of local codes.

- Gas piping should always be done in accordance with local codes.
- Tighten all joints securely.
- Pipe unions should be a “ground joint” type to prevent leakage.
- Provide adequate support for field-installed piping to avoid placing stress on the gas train and controls.
- Run takeoff lines from the side or top of the main gas line to prevent moisture from being drawn into the gas train of the unit.
- Provide a drip leg in the field-installed piping, installing it near the unit.

**Table 7. Gas supply line connection sizes**

Gas heater output capacity (MBh)	95, 205, 240, 325, 405, 485	625, 970
Connection size (NPT)	1 inch	1.5 inch

## Proper Gas Pressure

### NOTICE

#### Excessive Gas Pressure!

Failure to maintain proper gas pressure could result in damage to the gas train components. The gas pressure at the inlet to the gas train must not exceed 13 in. wc. A properly sized gas regulator that provides a maximum of 13 in. wc. of gas pressure, must be supplied in the gas inlet line to unit.

- To assure sufficient gas pressure at the unit, use appropriately sized gas pipe for unit capacity. Refer to the National Fuel Gas Code for pipe sizing information.
- Select an appropriately sized gas pressure regulator to assure the required gas supply pressure is maintained at the unit.
- For unit to operate unit properly, the inlet gas pressure must be maintained at 7 inches wc. Required gas pressure to the gas train is 5 to 13 inches wc.
- Gas pressure and volume must be maintained and stable at high fire.
- If the gas pressure regulator serves more than one heating unit, it must be sized appropriately to ensure that the inlet gas pressure at each unit is 5 to 13 inches wc while all burners are firing.
- Check the gas supply pressure before making the final connection to the unit. If the gas pressure is too high, damage to the gas valve could occur.

## Heat Exchanger Condensate Piping

Condensate usually does not form in the heat exchanger during normal heating operation. However, if the unit operates for extended periods of time at very low fire, or if the air handler serves as a cooling unit also, condensate can form in the heat exchanger and should be removed.

All units are equipped with a condensate drain. The condensate drain is on the same side as the gas train.

If a p-trap and drain is to be connected to the condensate drain line, consult local plumbing codes for disposal of the condensate may be a slightly acidic solution.



# Wiring

**⚠ WARNING**

**Proper Field Wiring and Grounding Required!**

Failure to follow code could result in death or serious injury. All field wiring **MUST** be performed by qualified personnel. Improperly installed and grounded field wiring poses **FIRE** and **ELECTROCUTION** hazards. To avoid these hazards, you **MUST** follow requirements for field wiring installation and grounding as described in **NEC** and your local/state/national electrical codes.

**⚠ WARNING**

**Hazardous Voltage!**

Failure to disconnect power before servicing could result in death or serious injury. Disconnect all electric power, including remote disconnects before servicing. Follow proper lockout/tagout procedures to ensure the power can not be inadvertently energized. Verify that no power is present with a voltmeter.

**NOTICE**

**Use Copper Conductors Only!**

Failure to use copper conductors could result in equipment damage as the equipment was not designed or qualified to accept other types of conductors.

## Wiring Checklist

- All field wiring must be in accordance with the National Electric Code and state and local requirements.

**Table 8. Motor and electrical specifications**

Specifications	Gas Heater Input Power	Inducer Motor <sup>(a)</sup>	Control Power <sup>(a)</sup>
Volts		115	115
Hertz	60	60	60
Phase		1	1
HP	n/a		n/a
FLA/Amps	n/a		6

(a) Powered by a "line to 115 volt" transformer for all gas heaters except 115/60/1 rated units.

Single-phase 120, 208, 230, 460 or 575 volt power is required to operate the heater controls or power the transformer (TRANS1), if provided.

Single-phase power for 208, 230, 460, and 575 voltage is provided for the gas heat off two legs of the three-phase supply to the air-handling unit. A transformer in the piping vestibule is provided to step down the voltage required for gas heat.

- All wiring (including low-voltage wiring) must be copper conductors only with the insulation rated for 600V.
- Refer to the nameplate located on the gas heater section for the proper Input Voltage, Minimum Circuit Ampacity (MCA) and Maximum Overcurrent Protection (MOP) requirements for proper electrical installation.
- Input voltage must be within +/- 10 percent of specified value.
- Ground the supply power in the junction box to the ground lead provided.
- Do not route any wires through the heat exchanger section unless the insulation is rated for 600°F or higher. Radiant heat from the heat exchanger will damage wire insulation that is unsuitable for high temperatures.
- See table in the next section for electrical specifications.

**Note:** Factory wiring routed through the heated part of the cabinet has insulation rated for 600°F.

## High-Voltage Wiring

### Wiring Entrance Locations

Indoor air handlers can accept conduit penetrations on any side of the piping vestibule. For outdoor air handlers, the recommended conduit entrance into the gas heat section is through the floor of the piping vestibule.

Terminate conduits on the power junction box or gas heater control panel as appropriate.



## Low-Voltage Wiring

### **NOTICE**

#### **Equipment Damage!**

**Do not operate the gas heat system without a supply fan providing airflow. Operating the gas heat system without a supply fan could result in damage to equipment or property.**

The gas heat control system requires a binary signal for on/off control. A field provided interlock is recommended in the start-stop signal circuit with the air handler supply fan. This interlock must insure the start-stop signal is interrupted to the gas heat system if the supply fan is shut off. The gas heat system must not operate without the supply fan providing airflow.

The control system also requires a 2 to 10 Vdc analog signal for modulation where 10 Vdc is a signal for full heat.



# Start-Up — Indirect Gas-Fired Heating

## ⚠ WARNING

### Hazardous Service Procedures!

Failure to follow all precautions in this manual and on the tags, stickers, and labels could result in death or serious injury.

- Technicians, in order to protect themselves from potential electrical, mechanical, and chemical hazards, **MUST** follow precautions in this manual and on the tags, stickers, and labels, as well as the following instructions: Unless specified otherwise, disconnect all electrical power including remote disconnect and discharge all energy storing devices such as capacitors before servicing. Follow proper lockout/tagout procedures to ensure the power can not be inadvertently energized. When necessary to work with live electrical components, have a qualified licensed electrician or other individual who has been trained in handling live electrical components perform these tasks.
- Do not attempt the following procedures until all electrical and gas connections to the unit have been completed and the outdoor air damper and evaporator fan operation have been verified and are operating correctly.

### Notes:

1. This furnace module does not have a pilot. It is equipped with a direct spark ignition device that automatically lights the gas burner. DO NOT try to light burners by hand.

## ⚠ WARNING

### Hazard of Explosion!

Failure to follow proper safe leak test procedures could result in death or serious injury or equipment or property-only-damage. NEVER use an open flame to detect gas leaks. You **MUST** use a leak test solution for leak testing.

2. BEFORE OPERATING, leak test all gas piping up to heater gas valve. Smell around the unit area for gas. If gas is smelled, do NOT attempt to place heater in operation until source of gas leak is identified and corrected.
3. Use only hand force to operate the gas control lever to the "ON" position. NEVER use tools. If lever does not operate by hand, replace gas valve prior to starting the unit. Forcing or attempting to repair the gas valve may result in fire or explosion.
4. Do not attempt to operate unit, if there is indication that any part or control has been under water. Any control or component that has been under water must be replaced prior to trying to start the unit.

## Gas Heat Application Rules — Inshot

- The maximum allowable temperature rise is as listed in table for minimum cfm.
- Nominal airflow is based on 500 fpm through a nominal coil (i.e. 500 x unit size 8 = 4000 cfm).
- The minimum allowable airflow at full fire is 75 percent of the nominal airflow (i.e. 0.75 x 500 x unit size 8 = 3000 cfm).
- The minimum allowable airflow at reduced fire is 50 percent of the nominal airflow (i.e. 0.50 x 500 x unit size 8 = 2000 cfm).
- Calculate temperature rise at airflows other than nominal with this equation:  $\text{Temp Rise} = (1000 \times \text{MBh}) / (1.1 \times \text{CFM})$
- On high altitude applications, derate the heating capacity (MBh) by 4 percent for every 1,000 feet of altitude over 2,000 feet above sea level.
- Temperature rise is listed for nominal cfm/minimum cfm.

## Start-up Procedure

1. Check Inlet Gas Pressure:  
Ensure the gas pressure supplied to the unit is within the pressure requirement listed on the nameplate. DO NOT expose gas controls to pressures above 13 inches wc). If required by local code, a field provided gas supply line should be installed with a field provided external manual shutoff and pressure tap.
2. Verify Fan Failure Switch Operation:  
The supply fan air proving switch is located in the heater electrical control compartment near the top of the heater panel. The switch will fail if not proven within 30 seconds of call for indoor fan—ON. All unit air filters must be clean before proceeding to properly complete this verification.

**Important:** *If the unit air filters are not clean, unit performance could be affected. Remove and clean or replace air filters as required prior to proceeding with the burner pressure testing.*

## ⚠ WARNING

### Hazardous Voltage and Gas!

Failure to turn off gas or disconnect power before servicing could result in an explosion or electrocution which could result in death or serious injury.

Turn off the gas supply and disconnect all electric power, including remote disconnects, before servicing the unit. Follow proper lockout/tagout procedures to ensure the power can not be inadvertently energized.

## Start-Up – Indirect Gas-Fired Heating

---

3. Confirm Gas Flow at Unit:  
Open door to unit vestibule housing the gas heater. Move gas control lever to “OFF” position. Remove 1/8-in. pressure taps from both modulating and on-off sections of the split heater manifold. Install a barbed fitting in both 1/8-in. tapped holes for connection to individual gas manometers.  
**Note:** *There is a third 1/8-in. gas pressure tap located in the pipe connecting the main valve/regulator and modulating valve. Maximum pressure into modulating valve is 5-in. The On-Off gas valve includes a regulator adjustment device that is located on the top of the valve. Use this device to regulate valve output to modulating valve as required.*
4. Wait 5 minutes for any gas to clear. If you smell gas, see [Step 2](#) and correct leak. If you do not smell gas or have corrected any leaks, then go to the next step.
5. Main Gas Supply:  
Turn manual gas cock “ON”.
6. Pre-purge and Ignition:
  - a. Open all manual gas valves.
  - b. Turn power on at the gas heat switch inside the gas heat vestibule.
  - c. A call for heat is initiated by the AHU unit control through a 0-10V analog signal.
  - d. The heater controller will then go through a system check to ensure that the high temperature limit and rollout switches are closed, the air pressure switch is open, and the modulating valve is positioned correctly.
  - e. The control will then enter the pre-purge cycle, where the inducer will run at the programmed purge pressure. During this cycle, the control will look for the air pressure switch to close and open at the correct settings.
  - f. Once the system check and pre-purge cycles are complete, the control will enter the ignition cycle. The modulating valve and inducer will go to their “light off” settings.  
The DSI ignition module will be energized and the spark ignitor will activate.  
The redundant safety valve will open, allowing gas flow.  
The burners will ignite and the control will receive a signal from the flame sensor.  
The spark ignitor will remain active for the duration of the ignition cycle, regardless of flame status.
  - g. If flame is not established during the ignition cycle, the control will repeat the pre-purge and ignitions cycles up to three times. After three failed ignition attempts, the board will enter a 1 hour lockout.
  - h. Once flame has been established, the control will enter a warm-up period to ensure flame stabilization and reduce condensation in the heat exchanger.
- i. After the warm-up period, the control will enter the run cycle. During the run cycle, the burner firing rate and draft inducer pressure are determined based on the heat demand received by the control via a 0-10V analog signal.  
**Note:** *If the control is paired with a split manifold, [Step c](#) through [Step h](#) pertain to the primary burners. Once the control exits the warm-up period and the firing rate is dictated by the rooftop control, the control will ignite the secondary burners and modulate the primary burners based on the demand for heat.*
- j. The run cycle will continue until any of the following conditions are met.
  - The call for heat is terminated.
  - Any of the safety devices (high limit, air pressure, rollout, etc.) are triggered.
  - The control reaches the maximum run time of 6 hours. If this condition is reached, the control will terminate the run cycle, continue through the proper sequence of operations, and then immediately enter the system check and pre-purge cycles to prepare for re-ignition, assuming conditions A and B have not been met.
- k. Once the run cycle has terminated, the redundant safety valve will close, the modulating valve will return to its set position, and the draft inducer will ramp up to its “light-off” setting for a 45 second post-purge cycle.
- l. After the conclusion of the post-purge, the control will enter the “OFF” state. All system outputs are de-energized but all safety devices are still monitored.
- m. When the building management system temperature is satisfied and the demand for heat ends, the gas valve is de-energized immediately and the combustion blower is energized on high speed for 30-seconds post-purge period.
- n. If the unit fails to ignite, see Troubleshooting chapter.

**Figure 11. Flame characteristics of properly-adjusted natural gas systems**

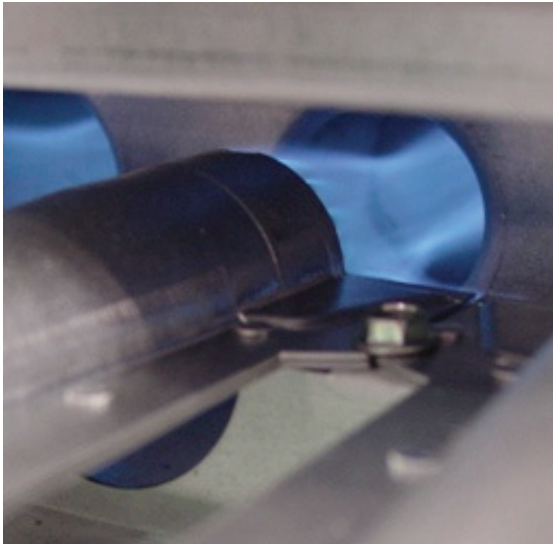

Burner flame at start-up: 1.2-inch w.c. manifold pressure draft inducer – high speed

**Figure 12. Flame characteristics of properly-adjusted natural gas systems**

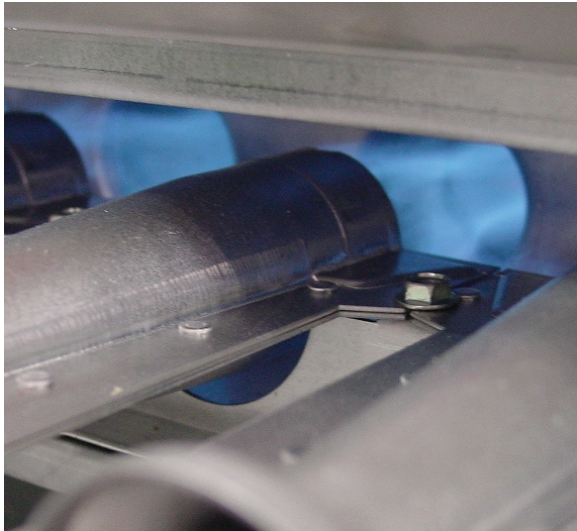

Burner flame at high fire: 3.5 in. wc manifold pressure draft inducer—high speed

### Main Burner Flame

- The burner flame should be predominately blue in color and well defined and centered at the tube entry as shown in the previous figure above. Distorted flame or yellow tipping of natural gas flame, or a long yellow flame on propane, may be caused by lint and dirt accumulation inside burner or at burner ports, at air inlet between burner and manifold pipe, or debris in the main burner orifice. Soft brush or vacuum clean affected areas.

- Poorly defined, substantially yellow flames, or flames that appear lazy, indicate poor air supply to burners or excessive burner input. Verify gas supply type and manifold pressure with rating plate.
- Poor air supply can be caused by obstructions or blockage in heat exchanger tubes or vent discharge pipe. Inspect and clean as necessary to eliminate blockage. Vacuum any dirt or loose debris. Clean heat exchanger tubes with stiff brush. Poor flame characteristics can also be caused by flue gas recirculation into combustion air supply. If surrounding buildings or prevailing winds cause recirculation, a flue extension may be required to prevent recirculation. Contact manufacturer prior to making any flue adjustments.
- Reduced air delivery can also be the result of inducer fan blade slippage, dirt accumulation in the fan blade or low voltage to draft inducer motor. Inspect draft fan assembly and be sure fan blade is secure to motor shaft. Check line voltage to heater.

### NOTICE

#### Meter Damage!

Measuring voltage with meter connect to a circuit could result in meter damage. Do NOT measure voltage with meter connected to a circuit.

- Flame Sensor Current Check:  
Flame current is the current which passes through the flame from the sensor to ground. A flame signal of 0.5 to 1.0 microamp ( $\mu\text{A}$ ) is marginal. For dependable operation, a flame signal of greater than 1.0  $\mu\text{A}$  is required. To measure flame current, connect a meter capable of reading micro-amp current so the flame signal will be read thru the meter's COM and  $\mu\text{A}$  connections. The meter should read greater than 1.0  $\mu\text{A}$ .  
**Note:** If the meter reads below "0" on scale, meter leads are reversed; disconnect power and reconnect meter leads for proper polarity.
- Manifold Pressure Adjustment:
  - The manifold pressure for high fire second stage should be at 3.5-inch wc, if it needs adjustment, adjust the HI Regulator on the two stage gas valve.
  - The manifold pressure for Low Fire First Stage should be set at 1.2-inch wc, if it needs adjustment, adjust the LO Regulator on the two stage gas valve.

## Safety Controls

**Figure 13. Component locations**

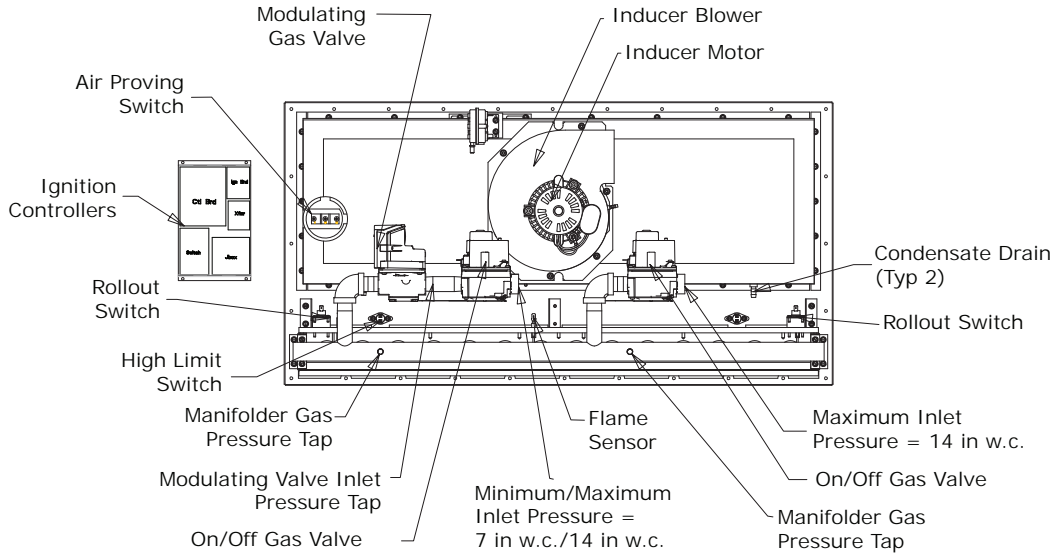

Component locations are approximate.

- **Inducer Air Proving Switch:**

An air pressure switch is provided as part of the control system to verify airflow through draft inducer by monitoring the difference in pressure between the draft inducer and the atmosphere. If sufficient negative pressure is not present, indicating lack of proper air movement through heat exchanger, the switch opens shutting off gas supply through the ignition control module. On units with two speed draft inducer operation, a dual air pressure switch is used, monitoring high and low speed pressures. The air pressure switches have fixed settings and are not adjustable.

- **Rollout Switch (Manual Reset):**

The furnace module is equipped with manual reset rollout switch(es) in the event of burner flame rollout. The switch will open on temperature rise and shut-off gas supply through the ignition control module. Flame rollout can be caused by insufficient airflow for the burner firing rate (high gas pressure), blockage of the vent system or in the heat exchanger. The furnace module should not be placed back in operation until the cause of rollout condition is identified and corrected. The rollout switch can be reset by pressing the button on top of the switch.

- **High Limit Switch:**

The furnace module is equipped with one or two fixed temperature high limit switches mounted on the vestibule panel that shuts off gas to the heater through the ignition control module in the event of reduced airflow over the heat exchanger tubes. Reduced airflow can be caused by indoor fan failure, dirty or blocked filters, or restriction of the air inlet or outlet to

the unit. The high limit switch will automatically reset when the air temperature drops to approximately 50°F below the limit setpoint. Determine the cause of the reduced air flow and correct.

- **Supply Fan Air Proving Switch:**

A supply fan air proving switch is provided as a part of the gas heat control system to verify air handling unit supply fan air flow across the heat exchanger by monitoring the difference in pressure between the gas heat plenum section and the atmosphere. If sufficient positive pressure is present, the switch will be closed. The air proving switch has fixed settings and is not adjustable.

## Normal Sequence of Operation

The gas heat module/section goes through the following routine every time it is started. The air handler fan must be running.

1. A call for heat is initiated by the AHU unit control through a 0-10V analog signal.
2. The 1285 control will then go through a system check to ensure that the high temperature limit and rollout switches are closed, the air pressure switch is open, and the modulating valve is positioned correctly.
3. The control will then enter the pre-purge cycle, where the inducer will run at the programmed purge pressure. During this cycle, the control will look for the air pressure switch to close and open at the correct settings.



4. Once the system check and pre-purge cycles are complete, the control will enter the ignition cycle. The modulating valve and inducer will go to their “light off” settings. The DSI ignition module will be energized and the spark ignitor will activate. The redundant safety valve will open, allowing gas flow. The burners will ignite and the control will receive a signal from the flame sensor. The spark ignitor will remain active for the duration of the ignition cycle, regardless of flame status.
5. If flame is not established during the ignition cycle, the control will repeat the pre-purge and ignitions cycles up to three times. After three failed ignition attempts, the board will enter a 1 hour lockout.
6. Once flame has been established, the control will enter a warm-up period to ensure flame stabilization and reduce condensation in the heat exchanger.
7. After the warm-up period, the control will enter the run cycle. During the run cycle, the burner firing rate and draft inducer pressure are determined based on the heat demand received by the control via a 0-10V analog signal.

**Note:** *If the control is paired with a split manifold, steps 1 through 6 pertain to the primary burners. Once the control exits the warm-up period and the firing rate is dictated by the rooftop control, the control will ignite the secondary burners and modulate the primary burners based on the demand for heat.*

8. The run cycle will continue until any of the following conditions are met.
  - a. The call for heat is terminated.
  - b. Any of the safety devices (high limit, air pressure, rollout, etc.) are triggered.
  - c. The control reaches it’s maximum run time of 6 hours. If this condition is reached, the control will terminate the run cycle, continue through the proper sequence of operations, and then immediately enter the system check and pre-purge cycles to prepare for re-ignition, assuming conditions A and B haven't been met.
9. Once the run cycle has terminated, the redundant safety valve will close, the modulating valve will return to its set position, and the draft inducer will ramp up to its “light-off” setting for a 45 second post-purge cycle.
10. After the conclusion of the post-purge, the control will enter the “OFF” state. All system outputs are de-energized but all safety devices are still monitored.
11. Operation will continue in high-fire mode until the signal from the building management controller drops to below 4.7 Vdc. At this point the gas heat control module de-energizes the second stage gas valve and the combustion blower switches to low speed.

12. When the building thermostat is satisfied and the demand for heat ends, the gas valve is de-energized immediately the combustion blower is energized on high speed for 30-second post-purge period.

## Normal Shutdown

The air-handling unit fan should run for a *minimum* of three to ten minutes after heater shutdown to cool the heat exchanger.

# Wiring Diagrams

Figure 14. Typical wiring diagram for 5:1 turndown heater

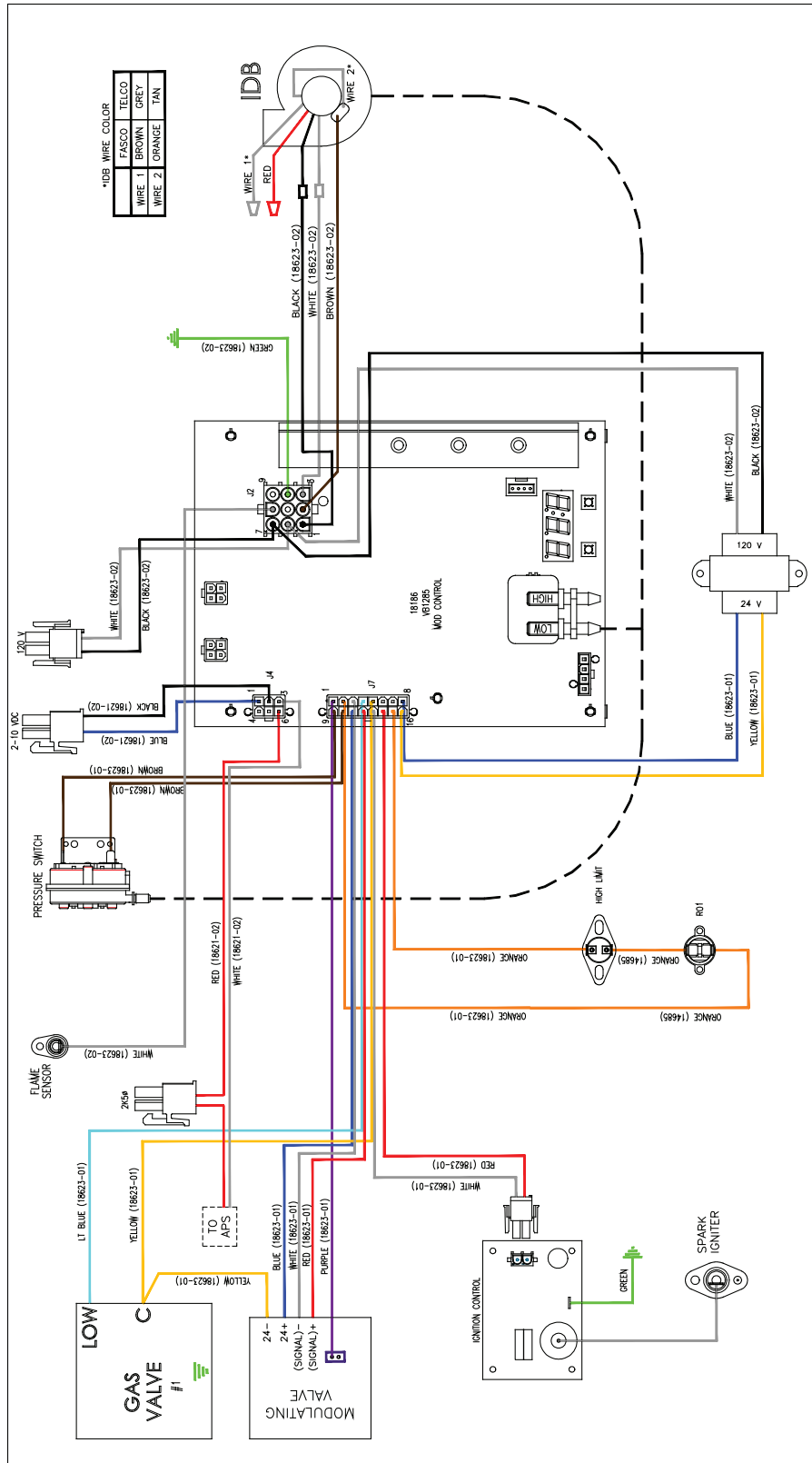

Figure 15. Typical wiring diagram for 10:1 turndown heater

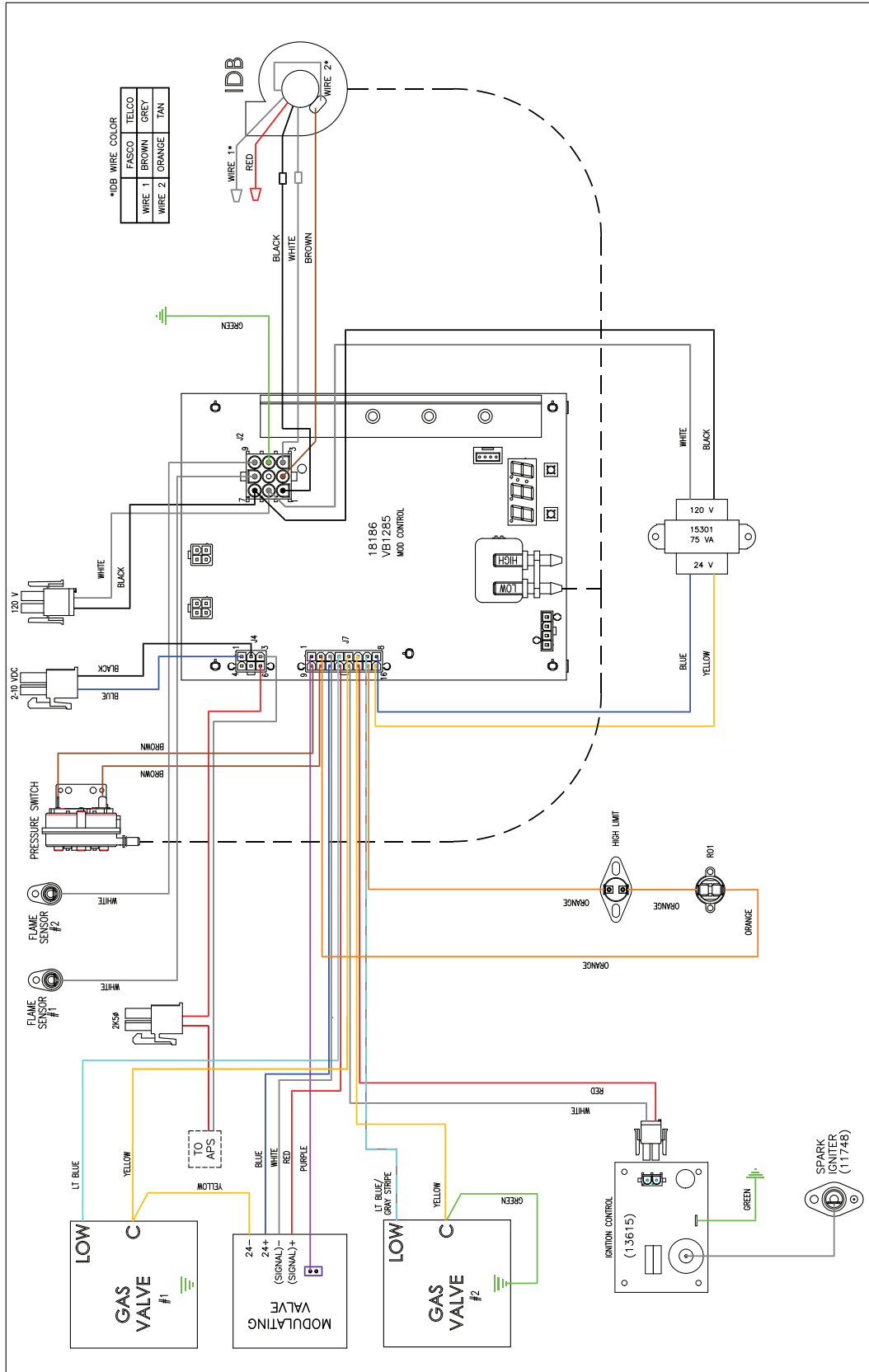
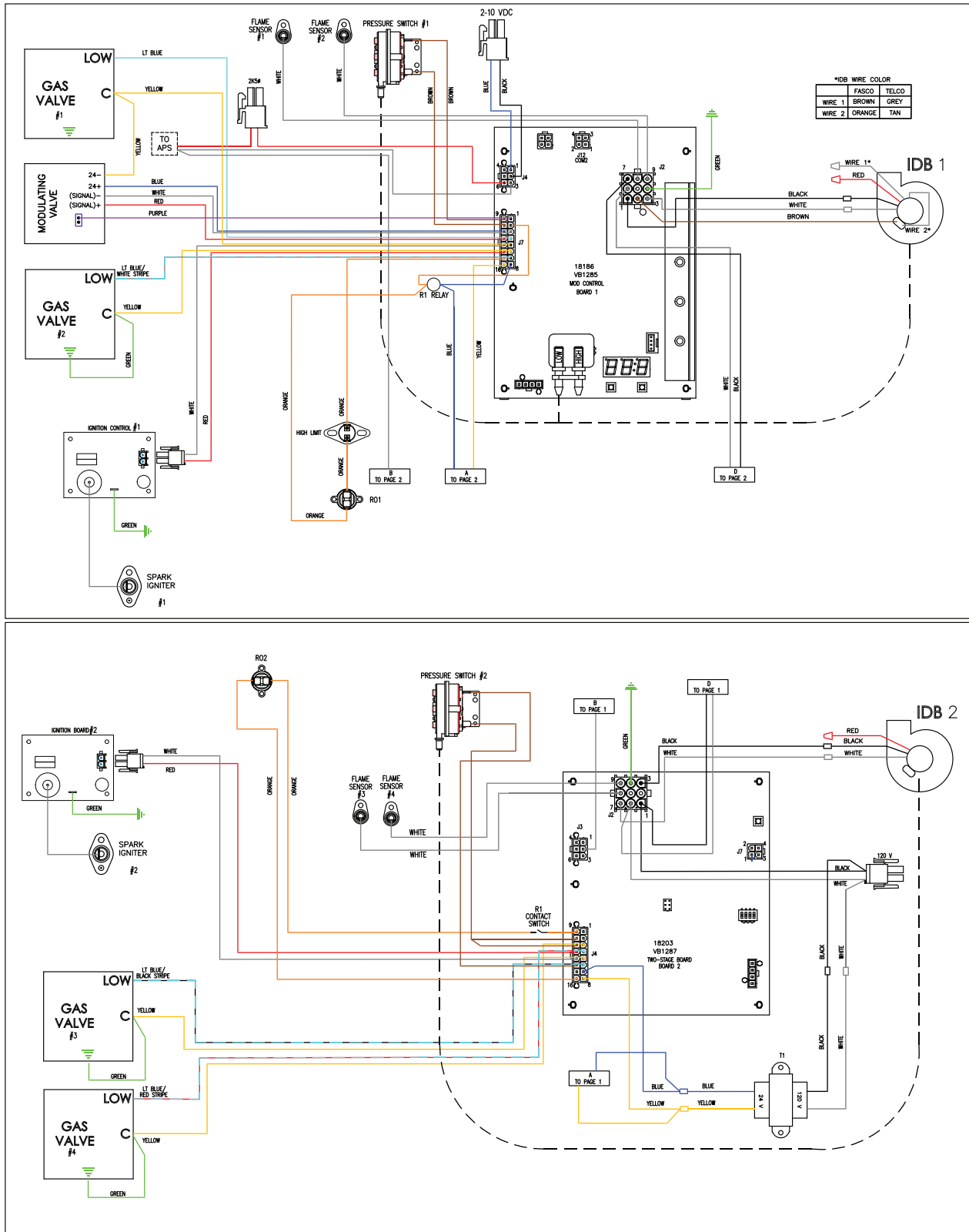

Figure 16. Typical wiring diagram for 20:1 turndown heater





# Routine Maintenance

**⚠ WARNING**

**Hazardous Gases and Flammable Vapors!**

Failure to follow all instructions could result in death or serious injury. Exposure to hazardous gases from fuel substances have been shown to cause cancer, birth defects or other reproductive harm. Improper installation, adjustment, alteration, service or use of this product could cause flammable mixtures or lead to excessive carbon monoxide. To avoid hazardous gases and flammable vapors follow proper installation and set up of this product and all warnings as provided in this manual. Failure to follow all instructions could result in death or serious injury.

**⚠ WARNING**

**Hazardous Voltage!**

Failure to disconnect power before servicing could result in death or serious injury. Disconnect all electric power, including remote disconnects before servicing. Follow proper lockout/tagout procedures to ensure the power can not be inadvertently energized. Verify that no power is present with a voltmeter.

**⚠ WARNING**

**Hazard of Explosion!**

Failure to follow proper safe leak test procedures could result in death or serious injury or equipment or property-only-damage. NEVER use an open flame to detect gas leaks. You MUST use a leak test solution for leak testing.

**Table 9. Routine maintenance for trained service personnel**

Task	Frequency	Remarks
Clean drain from heat exchanger	Annually	Required only if the unit runs for extended hours at low fire.
Clean air inlet louver/screen	Monthly	Use brush and vacuum cleaner.
Clean inducer blower and motor	Annually	Use brush and vacuum cleaner.
Clean exhaust flue	Annually	Use brush and vacuum cleaner.
Check combustion air inlets for obstruction. Remove debris	Annually	Use brush and vacuum cleaner.
Check gas piping for leaks	Annually	Use soap bubble solution or equivalent leak tester.

# Troubleshooting Guide

## ⚠ WARNING

### Hazardous Service Procedures!

Failure to follow all precautions in this manual and on the tags, stickers, and labels could result in death or serious injury.

Technicians, in order to protect themselves from potential electrical, mechanical, and chemical hazards, **MUST** follow precautions in this manual and on the tags, stickers, and labels, as well as the following instructions: Unless specified otherwise, disconnect all electrical power including remote disconnect and discharge all energy storing devices such as capacitors before servicing. Follow proper lockout/tagout procedures to ensure the power can not be inadvertently energized. When necessary to work with live electrical components, have a qualified licensed electrician or other individual who has been trained in handling live electrical components perform these tasks.

## ⚠ WARNING

### Hazardous Gases and Flammable Vapors!

Failure to observe the following instructions could result in exposure to hazardous gases, fuel substances, or substances from incomplete combustion, which could result in death or serious injury. The state of California has determined that these substances may cause cancer, birth defects, or other reproductive harm. Improper installation, adjustment, alteration, service or use of this product could cause flammable mixtures or lead to excessive carbon monoxide. To avoid hazardous gases and flammable vapors follow proper installation and setup of this product and all warnings as provided in this manual.

## VB1285 BPP Split Manifold Modulating Control

### VB1285 Sequence of Operations

1. A call for heat is initiated by the rooftop unit control through a digital Modbus signal or the analog thermostat.
2. The 1285 control will then go through a system check to ensure that the high temperature limit and rollout switches are closed, the air pressure switch is open, and the modulating valve is positioned correctly.
3. The control will then enter the pre-purge cycle, where the inducer will run at the programmed purge pressure. During this cycle, the control will look for the air pressure switch to close and open at the correct settings.
4. Once the system check and pre-purge cycles are complete, the control will enter the ignition cycle.

- a. The modulating valve and inducer will go to their "light off" settings.
  - b. The DSI ignition module will be energized and the spark ignitor will activate.
  - c. The redundant safety valve will open, allowing gas flow.
  - d. The burners will ignite and the control will receive a signal from the flame sensor.
  - e. The spark ignitor will remain active for the duration of the ignition cycle, regardless of flame status .
5. If flame is not established during the ignition cycle, the control will repeat the pre-purge and ignitions cycles up to three times. After three failed ignition attempts, the board will enter a 1 hour lockout.
  6. Once flame has been established, the control will enter a warm-up period to ensure flame stabilization and reduce condensation in the heat exchanger.
  7. After the warm-up period, the control will enter the run cycle. During the run cycle, the burner firing rate and draft inducer pressure are determined based on the heat demand received by the control via a Modbus signal or the analog thermostat.

**Note:** *If the control is paired with a split manifold, [Step 1](#) through [Step 6](#) pertain to the primary burners. Once the control exits the warm-up period and the firing rate is dictated by the rooftop control, the control will ignite the secondary burners and modulate the primary burners based on the demand for heat.*

8. The run cycle will continue until any of the following conditions are met.
  - a. The call for heat is terminated.
  - b. Any of the safety devices (high limit, air pressure, rollout, etc.) are triggered.
  - c. The control reaches it's maximum run time of 6 hours. If this condition is reached, the control will terminate the run cycle, continue through the proper sequence of operations, and then immediately enter the system check and pre-purge cycles to prepare for re-ignition, assuming conditions A and B haven't been met.
9. Once the run cycle has terminated, the redundant safety valve will close, the modulating valve will return to its set position, and the draft inducer will ramp up to its "light-off" setting for a 45 second post-purge cycle.
10. After the conclusion of the post-purge, the control will enter the "OFF" state. All system outputs are de-energized but all safety devices are still monitored.

**Table 10. Troubleshooting guide for VB1285 modulating control**

LED Display	Diagnostic Code	Type	Description	Action
<b>888</b>	1	Lockout	Board Failure <i>(Also during power up)</i>	
<b>OFF</b>	2	Status	UP Mode: Burner state = Off	
<b>Pur</b>	3	Status	UP Mode: Burner state = Purge	
<b>16n</b>		Status	UP Mode: Burner state = Ignition	
<b>HEA</b>		Status	UP Mode: Burner state = Warmup	
<b>run</b>		Status	UP Mode: Burner state = Run	
<b>rEt</b>	4/5	Status	UP Mode: Burner state = Retry	
<b>A01</b>	4	Alert	Failed Ignition attempt	<ol style="list-style-type: none"> <li>Check for flame during ignition period <ul style="list-style-type: none"> <li>If flame is present but A01 persists, check flame sense wiring and sensor condition for main burner</li> <li>Repair wiring and clean/replace sensor as needed</li> <li>If flame is present and flame sense wiring is OK, check polarity of 120V wiring to control board</li> </ul> </li> <li>Check for spark during ignition attempt <ul style="list-style-type: none"> <li>If no spark present, check ignition board/ignitor wiring and condition of ignitor</li> <li>Clean or replace ignitor if damaged/corroded</li> </ul> </li> <li>Check for gas flow/manifold pressure during ignition attempt <ul style="list-style-type: none"> <li>Refer to unit rating plate for Max/Min pressures</li> <li>If no gas present, check incoming line pressure</li> <li>If incoming line pressure is OK, check valve wiring</li> </ul> </li> </ol>
<b>A02</b>	5	Alert	Lost Flame	<ol style="list-style-type: none"> <li>Check flame sensor wiring and condition <ul style="list-style-type: none"> <li>If flame sensor is corroded/ damaged, clean or replace</li> </ul> </li> <li>Check for gas flow/manifold pressure <ul style="list-style-type: none"> <li>If no gas present, check valve wiring</li> <li>Refer to unit rating plate for Max/Min pressures</li> </ul> </li> <li>Check for flue gas leaks in vent ducting in and around burner compartment</li> </ol>
<b>A03</b>	6	Alert	Insufficient Combustion Air—auto-derating	<ol style="list-style-type: none"> <li>Check flue vent ducting and chimney/ vent hood for blockage</li> <li>Check pressure tubing from draft Inducer to air pressure switch and Control board for leaks or blockage</li> </ol>
<b>A04</b>	7	Alert	Limited Low Fire <i>(due to Lost Flame Auto Adaption)</i>	See A02: Lost flame
<b>A05</b>	8	Alert	Weak Flame Signal, Main burner	<ol style="list-style-type: none"> <li>Check main burner flame condition <ul style="list-style-type: none"> <li>If flame is weak, check gas manifold pressure</li> <li>Refer to unit rating plate for Max/Min pressures</li> </ul> </li> <li>Check main burner flame sensor condition <ul style="list-style-type: none"> <li>If flame sensor is corroded/ damaged, clean or replace</li> <li>Flame sensor should be immersed in flame</li> </ul> </li> </ol> <p><b>Note:</b> Consult appliance manufacture's technical support before adjusting flame sensor</p>
<b>A06</b>	9	Alert	Reserved	
<b>A07</b>	33	Alert	Air Modulating Failure (Inducer is not modulating down)	<ol style="list-style-type: none"> <li>Check draft inducer wiring from J2 board connector to draft inducer motor <ul style="list-style-type: none"> <li>Compare against supplied wiring diagram</li> <li>Check for wiring continuity and / or damage</li> </ul> </li> </ol>
<b>A08</b>	34	Alert	Air Sensor Null Pressure Check (out of tolerance)	Check pressure tubing from draft Inducer to pressure switch and control board for leaks/blockage
<b>A11</b>	24	Alert	Failed Ignition, Split manifold burner, retries exhausted	<ol style="list-style-type: none"> <li>Check for flame during split burner ignition period <ul style="list-style-type: none"> <li>If flame is present but A11 persists, check flame sense wiring and sensor condition for split burner</li> <li>Repair wiring and clean/replace sensor as needed</li> </ul> </li> <li>Check for gas flow/manifold pressure during split burner ignition period <ul style="list-style-type: none"> <li>If incoming line pressure is OK, check valve wiring</li> </ul> </li> </ol>

## Troubleshooting Guide

**Table 10. Troubleshooting guide for VB1285 modulating control (continued)**

LED Display	Diagnostic Code	Type	Description	Action
A15	10	Alert	Weak Flame Signal, one or more split-manifold staged burners	<ol style="list-style-type: none"> <li>Check split burner flame condition <ul style="list-style-type: none"> <li>If flame is weak, check gas manifold pressure</li> </ul> </li> <li>Check spit burner flame sensor condition <ul style="list-style-type: none"> <li>If flame sensor is corroded/ damaged, clean or replace</li> <li>Flame sensor should be immersed in flame</li> </ul> </li> </ol> <p><b>Note:</b> Consult appliance manufacturer's technical support before adjusting flame sensor</p>
E01	11	Lockout	Failed Ignition, retries have been exhausted	See A01: Failed Ignition Attempt
E02	12	Lockout	Primary Limit Failure (or open fuse)	<ol style="list-style-type: none"> <li>Check 3 AMP fuse control board <ul style="list-style-type: none"> <li>If fuse is blown, check 24V wiring for a short to ground before replacing fuse</li> </ul> </li> <li>If control is cycling on limit switch (ignition, run, E02 Limit Failure, cool down, repeat) check appliance inlet/ outlet air streams for blockage <ul style="list-style-type: none"> <li>Check that outlet air temperature is not above manufacturer's rated limit</li> </ul> </li> <li>With appliance off and at ambient temperature, check for continuity through the primary limit circuit <ul style="list-style-type: none"> <li>Check circuit as a whole as well as each component individually (temperature limit switches, flame roll out switches, and any auxiliary safety devices in the circuit)</li> </ul> </li> </ol>
E03	13	Lockout	Modulating Valve Failure	<ol style="list-style-type: none"> <li>Check wiring to modulating valve</li> <li>Check that valve position feedback wire (purple with red 2 pin connector) is installed properly on valve</li> <li>Check for 24 Vac to valve when control is powered</li> <li>Check condition and location if SIG +/- wires at valve</li> <li>If wiring is correct/in good condition, 24 Vac is present at valve, and E03 persists, replace modulating valve</li> </ol>
E04	14	Lockout	Air Pressure Sensor Reading Low (Pressure switch failed to open or insufficient air/ blocked vent)	<ol style="list-style-type: none"> <li>With the control off and pressure tubing unhooked from switch, check continuity through switch contacts (switch should be open) <ul style="list-style-type: none"> <li>If there is continuity through switch, replace component</li> </ul> </li> <li>Ensure that switch is mounted in proper orientation <ul style="list-style-type: none"> <li>Switch should be mounted vertically, with pressure tap pointed down</li> <li>Rotate switch if necessary</li> </ul> </li> <li>Check air pressure switch wiring <ul style="list-style-type: none"> <li>Trace wires or check continuity from control board to switch</li> </ul> </li> <li>Check flue vent ducting/chimney/vent hood for blockage</li> </ol>
E05	15	Lockout	Air Pressure Sensor Reading High (Pressure switch fail to close)	<ol style="list-style-type: none"> <li>With control in purge cycle and pressure tubing connected to switch, check continuity through switch contacts (switch should be closed) <ul style="list-style-type: none"> <li>If there is no continuity through switch, use monometer to check that draft inducer pressure is greater than switch setting</li> <li>If pressure is sufficient and switch does not close, replace component</li> </ul> </li> <li>Check pressure tubing from draft Inducer to pressure switch and board for leaks/blockage</li> <li>Check air pressure switch wiring <ul style="list-style-type: none"> <li>Trace wires or check continuity from control board to switch</li> </ul> </li> </ol>
E08	18	Lockout	Unexpected Flame (main burner)	<ol style="list-style-type: none"> <li>Check flame sensor wiring <ul style="list-style-type: none"> <li>Trace wires/check continuity to ensure the main and split burner flame sensor wires are in the proper locations in J2 connector on control board</li> </ul> </li> <li>Check split and main manifold Pressure to ensure that correct gas valve is opening during ignition trial <ul style="list-style-type: none"> <li>If incorrect valve is opening, check wiring to all gas valves</li> </ul> </li> <li>Ensure the main burner gas valve is closing properly by monitoring main burner manifold pressure when control enters post-purge cycle <ul style="list-style-type: none"> <li>Replace valve if not closing properly</li> </ul> </li> </ol>



**Table 10. Troubleshooting guide for VB1285 modulating control (continued)**

LED Display	Diagnostic Code	Type	Description	Action
E09	19	Lockout	No R-W Enable Signal During Call For Heat	<ol style="list-style-type: none"> <li>Check for 24 Vac at pin 6 and at pin 3 in J4 connector on control board <ul style="list-style-type: none"> <li>If 24 Vac not present at either pin, check 24 Vac wiring from transformer to control board</li> <li>If 24 Vac present at pin 6 but not at pin 3, check safeties/switches and wiring in the thermostat/ R+W circuit (between pin 6 and 3)</li> </ul> </li> </ol>
E13	23	Lockout	Open Fuse	<ol style="list-style-type: none"> <li>Check 3 AMP fuse control board <ul style="list-style-type: none"> <li>If fuse is blown, check 24V wiring for a short to ground before replacing</li> </ul> </li> </ol>
E18	22	Lockout	Unexpected Flame (split burner)	<ol style="list-style-type: none"> <li>Check flame sensor wiring <ul style="list-style-type: none"> <li>Trace wires/check continuity to ensure that main and split burner flame sensor wires are in the proper locations in J2 connector on control board</li> </ul> </li> <li>Check split and main manifold pressure to ensure that correct gas valve is opening during ignition trial <ul style="list-style-type: none"> <li>If incorrect valve is opening, check wiring to all gas valves</li> </ul> </li> <li>Ensure that split burner gas valve is closing properly by monitoring split burner manifold pressure when control enters post-purge cycle <ul style="list-style-type: none"> <li>Replace valve if not closing properly</li> </ul> </li> </ol>
Ed	20	Lockout	Invalid I.D. Plug Installed	<ol style="list-style-type: none"> <li>Ensure that an I.D. plug is installed in the control board</li> <li>If I.D. plug is installed and Ed error persists, replace I.D. chip with appropriate replacement part number</li> </ol>

## VB1287 Sequence of Operations

- A call for heat is initiated by the rooftop unit control through a digital Modbus signal or the analog thermostat.
- The VB1287 control will then go through a system check to ensure that the high temperature limit and rollout switches are closed, the air pressure switch is open, and the modulating valve is positioned correctly.
- The control will then enter the pre-purge cycle, where the inducer will run at the programmed purge pressure. During this cycle, the control will look for the air pressure switch to close and open at the correct settings.
- Once the system check and pre-purge cycles are complete, the control will enter the ignition cycle.
  - The inducer will go to its "light off" setting (usually high speed).
  - The DSI ignition module will be energized and the spark ignitor will activate.
  - The safety valve will open, allowing gas flow.
  - The burners will ignite and the VB1287 control will receive a signal from the flame sensor.
  - The spark ignitor will remain active for the duration of the ignition cycle, regardless of flame status.
- If flame is not established during the ignition cycle, the control will repeat the pre-purge and ignition cycles up to three times. After three failed ignition attempts, the board will enter a 1 hour lockout.
- Once flame has been established, the control will enter a warm-up period to ensure flame stabilization and reduce condensation in the heat exchanger.
- After the warm-up period, the control will enter the run cycle. During the run cycle, the burner firing rate is determined by the heat demand received by the control via a Modbus signal or the analog thermostat. Two firing stages, High or Low, are available.

**Note:** If the control is paired with a split manifold, [Step 1 through Step 6](#) pertain to the primary burners. Once the control exits the warm-up period and the firing rate is dictated by the rooftop control, the control will ignite the secondary burners and step High or Low the primary burners based on the demand for heat.
- The run cycle will continue until any of the following conditions are met.
  - The call for heat is terminated.
  - Any of the safety devices (high limit, air pressure, rollout, etc.) are triggered.
  - The control reaches its maximum run time of 6 hours. If this condition is reached, the control will terminate the run cycle, continue through the proper sequence of operations, and then immediately enter the system check and pre-purge cycles to prepare for re-ignition, assuming conditions A and B have not been met.
- Once the run cycle has terminated, the redundant safety valve will close, the modulating valve will return to its set position, and the draft inducer will ramp up to its "light-off" setting for a 45 second post-purge cycle.

## Troubleshooting Guide

10. After the conclusion of the post-purge, the control will enter the "OFF" state. All system outputs are de-energized but all safety devices are still monitored.

**Table 11. Troubleshooting guide for VB1287**

Failure	Code	Description of Symptom	Actions
eFLAME_SPLIT	21	Flame is detected without call for heat	<ol style="list-style-type: none"> <li>1. Ensure there is no voltage to gas valve—repair/replace wiring if voltage is present.</li> <li>2. If voltage is not present, check for gas flow. If gas is flowing, verify line and manifold pressures before replacing valve</li> </ol>
eAIR_FLOW_LOW eAIR_FLOW_HIGH	43 44	Low pressure switch is open High pressure switch is open	<ol style="list-style-type: none"> <li>1. Failed combustion blower</li> <li>2. Check pressure switch hose for leaks or blockage</li> <li>3. Check for blockage in the inducer barb fitting</li> <li>4. Check for condensate accumulation in the pressure switch and hose</li> <li>5. Check the pressure switch wiring</li> <li>6. Replace the pressure switch</li> </ol>
eAIR_ZERO_LO eAIR_ZERO_HIGH	41	Low pressure switch closed at start High pressure switch closed at start	<ol style="list-style-type: none"> <li>1. Check wiring to the pressure switch and draft inducer</li> <li>2. Check pressure switch for closed contact using an OHM meter</li> <li>3. Replace the pressure switch</li> </ol>
eNO_IGNITION_PRIME eNO_IGNITION_SPLIT	12 22	Primary burner exceeds a number of trials for ignition Split burner exceeds number of trials for ignition, primary burner remains operational	<ol style="list-style-type: none"> <li>1. Verify gas supply available and manifold pressure is correct</li> <li>2. Verify the gas valve is in the ON position</li> <li>3. Verify that a spark is present; if not check igniter for debris between the electrodes, for cracked ceramic and check ignition wire for cracks</li> <li>4. Check to see if the sensor ceramic is cracked or if the electrode wire is coated with dirt or oils</li> <li>5. Check to see if the flame sensor wire is connected properly and not grounded due to wire abrasions.</li> <li>6. Check for air leaks</li> <li>7. Check for recirculation of flue product</li> </ol>
eFLAME_DROP_OUT_P RIMARY eFLAME_DROP_OUT_S PLIT	33 23	Primary burner flame loss count exceeds a threshold Split burner flame loss count exceeds a threshold	<ol style="list-style-type: none"> <li>1. Check to see if the sensor ceramic is cracked or if the electrode wire is coated with dirt or oils. Clean or replace</li> <li>2. Check to see if the sensor wire is connected properly and not grounded due to wire abrasions</li> <li>3. Check for re-circulation of flue product</li> <li>4. Check to see if the flame is unstable or floating away from the sensor</li> <li>5. Check that all burner components are assembled correctly and all seals are tight</li> </ol>
ePRIMARY_LIMIT	51	Primary limit and/or rollout switches are open	<ol style="list-style-type: none"> <li>1. Determine which switches are open using an OHM meter</li> <li>2. If limit switch is open, check temperature rise and airflow over the heat exchanger</li> <li>3. If high limit does not reset with proper airflow, change limit</li> <li>4. If rollout switch is open check for flue vent blockage or air leaks in the cabinet</li> <li>5. Reset the rollout switch and observe the flame for signs of rolling out</li> </ol>
eGAS_VALVE_HI_PRIME eGAS_VALVE_HI_SPLIT eGAS_VALVE_HI_PRIME_ SPLIT	15 25 35	Prime burner staging failure. Gas valve is in the incorrect state. Split burner staging failure. Gas valve is in the incorrect state Both the split and primary gas valve are in the incorrect state	<ol style="list-style-type: none"> <li>1.) Check gas valve wiring</li> <li>2.) Check for shorts in 24V circuit</li> <li>3.) Replace control</li> </ol>

**Table 12. Specific for LED display**

Failures	Display Code	Color	Description
eID_PLUG	54	RED	ID plug failure. Note that control disable communication on the ID Plug failure
eSYSTEM	55	RED	Control board failure: gas valve relays, safety relays, etc

**Table 13. Specific for LED display**

Warnings	Display Code	Color	Description
Prime burner flame rod aged warning	11	yellow	Indicates that flame rod has low current
Split burner flame rod aged warning	21	yellow	Indicates that flame rod has low current
Prime and split burner flame rod aged warning	31	yellow	Indicates that both flame rods measured low current
Prime burner retry on the ignition or flame dropout	13	yellow	Call for heat prime burner is in RETRY
Split burner retry on the ignition or flame dropout	23	yellow	Call for heat split burner is in RETRY
Lost communication	52	yellow	Control is in idle mode, keep alive timeout is expired
Manual override	53	yellow	Control is in idle mode, manual override is in off position

**Table 14. Specific for LED display**

Normal operations	Display Code	Color	Description
	11	Green	Control is idle. Prime burner and split burner is in state OFF
	12	Green	Call for heat. Burner state PURGE
	13	Green	Call for heat. Prime burner is running. Burner states GAS_ON, WARMUP, RUN
	33	Green	Call for heat. Split and prime burners are running

**Table 15. Specific for LED display**

Split burner in lockout, prime is active operations	Display Code	Color	Description
	11	Green/yellow	Control is idle. Prime burner is in off. Split burner is in lockout
	12	Green/yellow	Call for heat. Burner state PURGE. Split burner is in lockout
	13	Green/yellow	Call for heat. Prime burner is running. Burner states GAS_ON, WARMUP

**Table 16. Specific for LED display**

Special failures	Display Code	Color	Description
24 Vac failure, ID Plug, or MCU initialization RA state, hard lockout	Steady red	Red	Control is not functional

Trane - by Trane Technologies (NYSE: TT), a global climate innovator - creates comfortable, energy efficient indoor environments for commercial and residential applications. For more information, please visit [trane.com](http://trane.com) or [tranetechnologies.com](http://tranetechnologies.com).

Trane has a policy of continuous product and product data improvement and reserves the right to change design and specifications without notice. We are committed to using environmentally conscious print practices.