



Installation, Operation, and Maintenance

Performance Climate Changer™ Air Handlers

Model TCFS and TCPA

Custom Air Handlers for Any Application



⚠ SAFETY WARNING

Only qualified personnel should install and service the equipment. The installation, starting up, and servicing of heating, ventilating, and air-conditioning equipment can be hazardous and requires specific knowledge and training. Improperly installed, adjusted or altered equipment by an unqualified person could result in death or serious injury. When working on the equipment, observe all precautions in the literature and on the tags, stickers, and labels that are attached to the equipment.



Introduction

Read this manual thoroughly before operating or servicing this unit.

Warnings, Cautions, and Notices

Safety advisories appear throughout this manual as required. Your personal safety and the proper operation of this machine depend upon the strict observance of these precautions.

The three types of advisories are defined as follows:

- WARNING** Indicates a potentially hazardous situation which, if not avoided, could result in death or serious injury.
- CAUTION** Indicates a potentially hazardous situation which, if not avoided, could result in minor or moderate injury. It could also be used to alert against unsafe practices.
- NOTICE** Indicates a situation that could result in equipment or property-damage only accidents.

Important Environmental Concerns

Scientific research has shown that certain man-made chemicals can affect the earth's naturally occurring stratospheric ozone layer when released to the atmosphere. In particular, several of the identified chemicals that may affect the ozone layer are refrigerants that contain Chlorine, Fluorine and Carbon (CFCs) and those containing Hydrogen, Chlorine, Fluorine and Carbon (HCFCs). Not all refrigerants containing these compounds have the same potential impact to the environment. Trane advocates the responsible handling of all refrigerants.

Important Responsible Refrigerant Practices

Trane believes that responsible refrigerant practices are important to the environment, our customers, and the air conditioning industry. All technicians who handle refrigerants must be certified according to local rules. For the USA, the Federal Clean Air Act (Section 608) sets forth the requirements for handling, reclaiming, recovering and recycling of certain refrigerants and the equipment that is used in these service procedures. In addition, some states or municipalities may have additional requirements that must also be adhered to for responsible management of refrigerants. Know the applicable laws and follow them.

WARNING

Proper Field Wiring and Grounding Required!

Failure to follow code could result in death or serious injury. All field wiring **MUST** be performed by qualified personnel. Improperly installed and grounded field wiring poses **FIRE** and **ELECTROCUTION** hazards. To avoid these hazards, you **MUST** follow requirements for field wiring installation and grounding as described in **NEC** and your local/state/national electrical codes.

WARNING

Personal Protective Equipment (PPE) Required!

Failure to wear proper PPE for the job being undertaken could result in death or serious injury. Technicians, in order to protect themselves from potential electrical, mechanical, and chemical hazards, **MUST** follow precautions in this manual and on the tags, stickers, and labels, as well as the instructions below:

- Before installing/servicing this unit, technicians **MUST** put on all PPE required for the work being undertaken (Examples; cut resistant gloves/sleeves, butyl gloves, safety glasses, hard hat/bump cap, fall protection, electrical PPE and arc flash clothing). **ALWAYS** refer to appropriate Safety Data Sheets (SDS) and OSHA guidelines for proper PPE.
- When working with or around hazardous chemicals, **ALWAYS** refer to the appropriate SDS and OSHA/GHS (Global Harmonized System of Classification and Labeling of Chemicals) guidelines for information on allowable personal exposure levels, proper respiratory protection and handling instructions.
- If there is a risk of energized electrical contact, arc, or flash, technicians **MUST** put on all PPE in accordance with OSHA, NFPA 70E, or other country-specific requirements for arc flash protection, **PRIOR** to servicing the unit. **NEVER PERFORM ANY SWITCHING, DISCONNECTING, OR VOLTAGE TESTING WITHOUT PROPER ELECTRICAL PPE AND ARC FLASH CLOTHING. ENSURE ELECTRICAL METERS AND EQUIPMENT ARE PROPERLY RATED FOR INTENDED VOLTAGE.**

⚠ WARNING**Follow EHS Policies!**

Failure to follow instructions below could result in death or serious injury.

- All Trane personnel must follow the company's Environmental, Health and Safety (EHS) policies when performing work such as hot work, electrical, fall protection, lockout/tagout, refrigerant handling, etc. Where local regulations are more stringent than these policies, those regulations supersede these policies.
- Non-Trane personnel should always follow local regulations.

Copyright

This document and the information in it are the property of Trane, and may not be used or reproduced in whole or in part without written permission. Trane reserves the right to revise this publication at any time, and to make changes to its content without obligation to notify any person of such revision or change.

Trademarks

All trademarks referenced in this document are the trademarks of their respective owners.

Revision History

Updated Constant K-Factors for Trane DDP™ fans table in the Start-up chapter.



Table of Contents

General Information	6	Outdoor Roof - Multiple Span	23
Nameplate	6	Indoor Roof	24
Operating Environment	7	Indoor Roof - Multiple Span	25
Unit Description	7	Base-to-Interior Wall	26
Factory-Mounted Controls	7	Stacked Unit	27
Pre-Packaged Solutions for Controls	7	Pipe Cabinet	28
Wiring	8	Component Installation Requirements	29
Pre-Installation	9	Fan Section	29
Receiving and Handling	9	Fan Isolation	30
Inspection	9	Adjusting the Isolators	30
Packaging/Shipping	9	Seismic Requirements	31
Handling	9	Anchor Requirements	31
Receiving Checklist	9	Hurricane Requirements	31
Jobsite Storage	9	Control Dampers	32
Outdoor Storage	10	Filters	32
Long-Term Storage	10	Front-Load Filters	32
Site Preparation	10	Side-Load Filters	33
Roof Curb Installation	11	2-inch or 4-inch Flat Side-Load Filters	33
Suggested Tools	11	Bag or Cartridge Side-Load Filters	33
Installation - Mechanical	12	Magnahelic Air Filter Gage	33
Lifting and Rigging	12	Outdoor Unit Weather Hood(s)	33
General Lifting Considerations	12	Duct Connections	34
Hoods and Pipe Cabinets	13	Bottom Opening Duct Installation	34
Unit Placement and Assembly	13	Fan Discharge Connections	35
Unit Placement	14	Damper Connections	35
Unit Assembly	14	Discharge Plenum Connections	35
Ceiling Suspension	15	Bell Mouth Discharge Connections	36
Assembly Instructions	16	Traq Damper Connections	36
Standard Roof Curb	16	Piping and Connections	37
Structural Roof Curb and I-Beam Dunnage	16	General Recommendations	37
Flat Concrete Pad	17	Drain Pan Trapping	37
Roof Curb for Large Unit with Shipping Splits	17	Steam Coil Piping	38
Joining Sections Edge-to-Edge	17	Water Coil Piping	40
Base with Flat Floor	19	Refrigerant Coil Piping	41
Base with Turned-Up Floor	20	Liquid Lines	42
Walls	21	Suction Lines	43
Outdoor Roof - Single Span	22	Expansion Valves	43
		Hot Gas Bypass	43

Remodel, Retrofit, or Replacement	44	Cleaning the CDQ Section	68
Field-Installed Evaporator Piping Examples	45	CDQ Service and Repair	68
Humidifier Piping and Connections	51	CDQ Bearing Replacement	69
Installation - Electrical	52	Energy Wheels	75
Start-Up	53	Cleaning the Energy Wheel	75
Pre-Startup Checklist	53	Energy Wheel Bearing and Motor Lubrication .	75
General Checks	53	Energy Wheel Drive Belt Adjustment	76
Fan-Related Checks	53	Energy Wheel Seal Adjustment	76
Coil-Related Checks	53	Energy Wheel Drive Motor and Pulley Replace-	76
Motor-Related Checks	54	ment	76
Unit Operation	54	Fans	77
Calculate Motor Voltage Imbalance	54	Inspecting and Cleaning Fans	77
Tension the Fan Belt	55	Bearing Set Screw Alignment	77
Determine Fan Speed	56	Torque Requirements	77
Align Fan and Motor Sheaves	57	Fan Bearing Lubrication	77
Check Multiple Belts	57	Motor Bearing Lubrication	78
Airflow Measuring Systems	57	Fan Motor Inspection	78
Traq™ Dampers	57	Filters	78
Fan Inlet Airflow Measuring System	59	Throwaway Filters	78
Wiring	59	Permanent Filters	78
Transmitter Sizing	59	Front Load Filters	79
Transmitter Calibration	59	Side Load Filters	79
.	59	2-inch or 4-inch Flat Side-Load Filters	79
Constant K-Factors	60	Cartridge or Bag Side-Load Filters	79
Maintenance	61	Ultraviolet (UV) Light Maintenance	79
Energy Wheel Startup	61	Cleaning the Bulbs	79
CDQ Wheel Startup	62	Replacing the Bulbs	80
External Insulating Requirements	62	Disposal of Bulbs	80
Routine Maintenance	63	Troubleshooting	81
Maintenance Checklist	63		
Air-to-Air Plate Heat Exchangers	64		
Coils	64		
Steam and Water Coils	64		
Refrigerant Coils	65		
Coil Winterization	66		
Moisture Purge Cycle	66		
Cleaning Non-Porous Surfaces	66		
Cleaning Porous Surfaces	67		
Drain Pans	67		
CDQ Desiccant Dehumidification Wheel	68		



General Information

Use this manual to install, startup, operate, and maintain the Performance Climate Changer™ air handler model TCFS. Carefully review the procedures discussed in this manual to minimize installation and startup difficulties.

Nameplate

Each Performance air handler includes a nameplate (see Figure 1) which identifies the type of section and functional components, customer tagging information, the unit serial number, the unit sales order number, the build-section position for installation, and the unit model number.

Note: The unit serial number and sales order number is required when ordering parts or requesting service for a Trane air handler.

Figure 1. Performance air handler section nameplate



TRANE®

PERFORMANCE CLIMATE CHANGER™
AIR HANDLER

PROJECT: TEST JOB 1

UNIT TAG: AHU-101

SALES ORDER NUMBER: (SO #)

SERIAL NUMBER: (serial #)

MODEL NUMBER: TCPA_ or TCFS_

EQ NUMBER: 99999

ELECTRICAL

	CKT-1	CKT-2	CKT-3	CKT-4	CKT-5	CKT-6
MINIMUM CURRENT AMPACITY:						
MAXIMUM OVERCURRENT PROTECTION:						
SHORT CIRCUIT CURRENT RATING:						
MAXIMUM VOLTAGE:						

Component	Voltage/ Phase/Hz	Motor HP	Max Applied Motor HP	FLA Amps	VFD Amps	CKT- #

COILS

Type	Row	QTY/HGT1	QTY/HGT2	QTY/HGT3	FLGH	Max Press (PSI)	Max Temp (°F)
W	4	3/48			100		
W	2	1/18			12		
NS	2	1/0			12		

NOTES



EXTERNAL MOTOR OVERLOAD DEVICE IN ACCORDANCE WITH THE NATIONAL ELECTRICAL CODE (OR NEC) IS REQUIRED WHEN NOT PROVIDED BY TRANE.

SUPPLY AIR TEMPERATURE LIMITATION: 104°F DRAW-THRU / 200°F BLOW-THRU

FIELD CONDUCTORS SHALL HAVE INSULATION RATING NOT LESS THAN 600V.

*-SCCR N/A PER UL 1995, 37.3, γ) EXCEPTION. (KA RMS SYM.) @MAXIMUM VOLTAGE:

THIS UNIT IS INTENDED FOR **INDOOR** USE.



Intertek
Order No. 9800882
Report No. 100898736DAL-001
Conforms to UL Standard 1995 3rd Ed

MANUFACTURED UNDER ONE OR MORE OF THE FOLLOWING PATENT NUMBERS:
5674125 5741180 6237354 6973795 7017356 7526903 8231334

TRANE WWW.TRANE.COM MADE IN U.S.A.

6

CLCH-SVX010D-EN

Operating Environment

The Performance Climate Changer™ air handler model TCFS is a custom air handler engineered for your specific indoor and outdoor applications. When considering the placement of the air handler, it is important to consider the operating environment. The acceptable ambient temperature range for unit operation is -40°F to 140°F (-40°C to 60°C).

For heating applications, a special motor may be required to withstand the higher temperatures. Motors with Class B insulation are acceptable for ambient temperatures up to 104°F, while motors with Class F insulation can withstand ambient temperatures to +140°F (60°C).

Note: Units with UL approval have a maximum ambient temperature requirement of 104°F. The customer should provide adequate freeze protection for the coils. See “Routine Maintenance,” p. 63 for more information.

Unit Description

The Performance Climate Changer custom TCFS air handler is designed for a variety of controlled-air applications. A typical unit consists of a fan, heating and/or cooling coils, filters, and dampers. See unit submittals for detailed descriptions.

Trane air handlers ship as complete assemblies or in sub-assemblies if shipping splits are required. Some assembly is required when the unit ships in subassemblies.

Your Trane sales team can make recommendations on component selection based on pre-tested performance data gathered in our labs, helping you to make a more informed decision when designing your HVAC system. Though not limited to pre-tested Trane components, validated performance is available for many options, including:

- Trane coils with high-efficient fin design to optimize coil to the nearest fin-per-foot
- Coils with the best moisture carryover limits in the industry
- Fans, including stacked, direct-drive plenum (SDDP™) fans for fan array applications
- Traq™ airflow monitoring stations
- Energy recovery wheels
- Unit sound data based on ARI 260 tests
- Cool Dry Quiet (CDQ™) desiccant dehumidification which breaks the dewpoint barrier using standard equipment, and uses less energy than comparable systems
- Trane catalytic air cleaning system (TCACS)

Years of research data help us accurately predict specific unit performance for coils, casing, air leakage, thermal performance, acoustics and energy recovery compliance.

Factory-Mounted Controls

Trane air handlers are available with a wide selection of factory-mounted controls, including controllers, motor starters, and variable frequency drives (VFD).

Most control components are mounted inside the unit. Depending on the system configuration, this may include damper actuators, dirty filter switches, averaging temperature sensors, and low limit switches. VFDs, starters, controllers, control transformers, static pressure transducers, DC power supplies, and customer interface relays will be in enclosures mounted on the inside of the unit.

Small items that cannot be factory-mounted, such as space temperature sensors, outside air temperature sensors, and humidity sensors, will ship inside the control enclosures, or packaged and shipped inside the fan or mixing box section. Larger items are shipped inside the fan section.

Note: All control valves ship directly to the “ship-to address” from the vendor unless another address is given on the Trane sales order.

All factory-mounted control systems (controls that are factory-wired to a unit controller or termination strip) ordered without starters or variable-frequency drives (VFDs) are provided with 120 to 24 Vac control transformers mounted and wired in the auxiliary control panel. The customer must provide 120 Vac control power, 50/60 Hz. A dedicated 15-amp circuit is recommended.

Factory-mounted control systems ordered with factory-mounted starters or VFDs are supplied with line to 24 Vac control transformers. No additional power wiring is required.

Pre-Packaged Solutions for Controls

If the air handler has been selected using one of Trane’s pre-packaged solutions options for controls, there are a number of resources available to aid in commissioning and start-up of the unit. These resources include commissioning sheets, graphics and technical application notes. The technical application notes include the control sequencing, Trane Graphic Programming (TGP) and Rover set-up files for the specific unit selected. These resources are available through your local Trane sales office.

For more information on controls, refer to the following manuals:

- Programmable Tracer® UC600 controllers
 - BAS-SVX45*-EN, *Installation, Operation, and Maintenance Tracer UC600 Programmable Controller*
 - BAS-SVP18*-EN *Tracer UC600 Programmable Controller for Packaged Outdoor Air Unit Integration Guide*
 - X39641178-01*, *UC600 Installation Instructions*
 - X39641191-01*, *Installing the Tracer TD7 Display*
 - BAS-SVX50*-EN, *Tracer TD7 Display for the Tracer UC600 Programmable Controller Installation, Operation, and Maintenance Guide*
- Variable Frequency Drives
 - BAS-PRC077-EN *Trane TR-150 Drive*
 - BAS-PRC034-EN *Trane TR-200 Series*



Wiring

⚠ WARNING

Proper Field Wiring and Grounding Required!

Failure to follow code could result in death or serious injury.

All field wiring **MUST** be performed by qualified personnel. Improperly installed and grounded field wiring poses **FIRE** and **ELECTROCUTION** hazards. To avoid these hazards, you **MUST** follow requirements for field wiring installation and grounding as described in **NEC** and your local/state/national electrical codes.

Entrances are generally provided for field-installation of high and low voltage wiring through a pipe/nipple connection in the unit depending on unit configuration with or without factory-mounted controls. Before installation, consider overall unit serviceability and accessibility before mounting, running wires (power), making penetrations, or mounting any components to the cabinet.

Wiring to the air handler must be provided by the installer and must comply with all national and local codes. The fan motor nameplate includes a wiring diagram. If there are any questions concerning the wiring of the motor, write down the information on the motor nameplate and contact your local Trane sales office.



Pre-Installation

Receiving and Handling

Inspection

Upon delivery, thoroughly inspect all components for any shipping damage that may have occurred, and confirm that the shipment is complete. See “Receiving Checklist” section for detailed instructions.

Note: *Delivery cannot be refused. All units are shipped F.O.B. factory. Trane is not responsible for shipping damage.*

Packaging/Shipping

As standard, air handlers ship as a complete unit or in individual sections to be field assembled. All air handler sections are stretch-wrapped or shrink-wrapped before shipping. All factory shipping protection should be removed upon delivery. This wrapping is for transit protection only.

Smaller components and hardware may be shipped separately, or shipped inside the unit. This hardware is typically packaged in a clear plastic envelope or cardboard box, and can be found inside the fan, mixing box, or access section.

Trane FlexFit™ Units

There may be circumstances where the unit has to be broken down smaller than an individual section. Trane can do that with our FlexFit™ units.

Once a FlexFit unit is assembled at the factory, each panel and subassembly is labeled and photographed. The unit is then disassembled and components are packaged onto pallets and shrink-wrapped for protection during shipment. The process enables the unit to be shipped in pieces to fit the exact size allowed for easy maneuverability into the space while minimizing assembly time on the jobsite.

Handling

Air handlers have an integral base frame designed with the necessary number of lift points for safe installation. See “Lifting and Rigging,” p. 12.

Receiving Checklist

Complete the following checklist immediately after receiving shipment to detect possible shipping damage.

- | |
|---|
| <input type="checkbox"/> Check to ensure that the shipment is complete. Small components may ship inside the unit or ship separately. Check the parts list to ensure all materials are present. If any component is missing, contact your local Trane sales office. |
| <input type="checkbox"/> Check all units, components, connections, and piping. Check fan wheel for free rotation by spinning manually. Check all doors, latches and hinges. Inspect interior of each unit or section. Inspect coils for damage to fin surface and coil connections. Check for rattles, bent corners, or other visible indications of shipping damage. Tighten loose connections. |
| <input type="checkbox"/> If a unit is damaged, make specific notations concerning the damage on the freight bill of lading. Do not refuse delivery. |
| <input type="checkbox"/> Notify the carrier’s terminal of the damage immediately by phone and mail. Request an immediate joint inspection of the damage by the carrier and consignee. |
| <input type="checkbox"/> Notify your Trane sales representative of the damage and arrange for repair. Do not attempt to repair the unit without consulting the Trane representative. |
| <input type="checkbox"/> Inspect the unit for concealed damage as soon as possible after delivery. Report concealed damage to the freight line. It is the receiver’s responsibility to provide reasonable evidence that concealed damage did not occur after delivery. Take photos of damaged material if possible.
Note: <i>Concealed damage must be reported within 15 days of receipt.</i> |

Jobsite Storage

Air handlers and field-installed accessories must be protected from the elements. A controlled indoor environment is recommended for proper storage.

Note: *All factory shipping protection should be removed, This wrapping is for transit protection only.*

The unit controller and all other electrical/electronic components should be stored in conditions of -20°F to 120°F and 5 to 95 percent relative humidity, non-condensing. Electrical components are not moisture-tolerant.



Outdoor Storage

NOTICE

Unit Corrosion Damage!

Plastic tarps can cause condensation to form in and on the equipment, which could result in corrosion damage or wet storage stains.
Use only canvas tarps to cover air handlers.

Outdoor storage is **not** recommended for units that will be installed indoors. However, when outdoor storage is necessary, several things must be done to prevent damage:

Note: *Keep the equipment on the original wooden blocks/skid for protection and ease of handling.*

- Select a well-drained area, preferably a concrete pad or blacktop surface.
- Place the unit on a dry surface or raised off the ground to assure adequate air circulation beneath the unit and to assure no portion of the unit will contact standing water at any time.
- Loosen the belt tension on the drive belts.
- Cover the unit securely with a canvas tarp.
- Do not stack units.
- Do not pile other material on the unit.

Long-Term Storage

For longer periods of storage, allow proper clearance around the unit to perform periodic inspections and maintenance on the equipment. While the unit is in storage:

- Every two weeks, rotate the fan and motor shaft 30 revolutions by hand. Check for free rotation.
- Every six months, check fan shaft bearings and grease lines. Add grease using a manual grease gun following the lubrications recommendations in ["Fan Bearing Lubrication," p. 77](#).
- Check the motor lubrication; remove and clean grease plugs and check for the presence of moisture in the grease. If moisture is present, remove the motor and send it to an authorized repair shop for bearing inspection/replacement. If no moisture is present, refer to the motor manufacturer's lubrication recommendation for proper lubrication.

Site Preparation

- Ensure the installation site can support the total weight of the unit; refer to the unit submittals for weights.
- Allow sufficient space for adequate free air and necessary service access. Refer to submittals for specific minimums.
- Allow room for supply and return piping, ductwork, electrical connections, and coil removal.
- Ensure there is adequate height for condensate drain requirements. See ["Drain Pan Trapping," p. 37](#).

Note: *If unit is installed in a mechanical room on a pad, inadequate height may necessitate core-drilling the floor to attain proper trap height. Insufficient height could inhibit condensate drainage and result in flooding the unit and/or equipment room.*

NOTICE

Microbial Growth!

Failure to follow instructions below could result in odors and damage to the equipment and building materials.

The floor or foundation must be level and the condensate drain at the proper height for proper drainage and condensate flow. Standing water and wet surfaces inside the equipment can become an amplification site for microbial growth (mold). If there is evidence of microbial growth on the interior insulation, it should be removed and replaced prior to operating the system.

- Confirm the roof curb or foundation of the mounting platform is level (+/- 1/8-inch overall) and large enough to accommodate the unit. Refer to the unit submittals for specific dimensions.
- Provide adequate lighting for maintenance personnel to perform maintenance duties.
- Provide permanent power outlets in close proximity to the unit for installation and maintenance.
- Depending upon job requirements, 120 Vac power may need to be provided for the unit controller. Refer to submittals for more information. A dedicated 15-amp circuit is recommended.
- Wiring for the air handler must be provided by the installer and must comply with all national and local electrical codes.
- The installer/contractor must provide a ceiling-suspended mounting frame designed to support the length, width, and weight of the entire air-handling unit. See ["Ceiling Suspension," p. 15](#) for more information.
- Rooftop curb-mounted units must be sealed tightly to the curb. Use proper sealants and roof-to-curb sealing techniques to prevent water and air leakage. *Refer to curb manufacturer's installation instructions for more details.*
- Preparation of the roof curb or pier mount and roof openings should be completed prior to lifting the unit to the roof.

Roof Curb Installation

Refer to curb manufacturer's installation instructions for more details.

It is recommended that the curb be installed directly on the support members and fastened to the supports using tack welds or other equivalent methods. Properly supported decking should be installed inside the air handler section of the curb when this method is used.

Figure 2. Cross section of typical curb installation on new construction

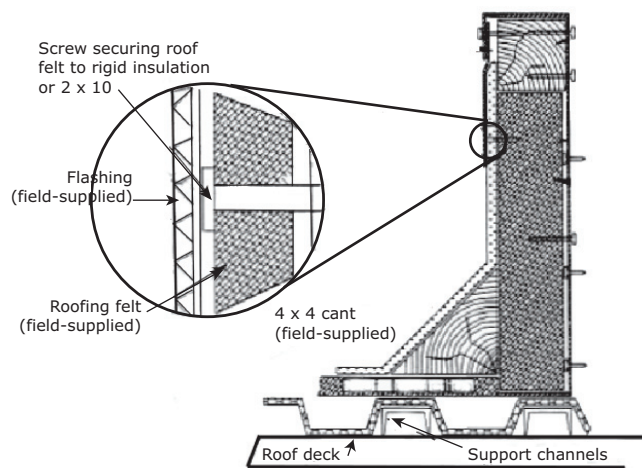

1. Verify that the roof structure can adequately support the combined weight of the unit and curb assembly.
2. Ensure that the selected installation location provides sufficient service and operational clearances.
3. Remove any twist within the curb due to roof supports and square the curb.
4. Level the curb.
5. Secure the curb to the roof support members.
6. Install 2-inch thick boards or rigid insulation around the curb.
7. Install cant strips around the curb.
8. Bring field supplied roofing felt up to the top of the curb nailing strips. Nail felt into place.
9. Apply sealant to the four corners. Caulk all joints between the curb and the roof. Attach the gasket material to the curb's top flanges (entire perimeter) and to the supply and return air duct opening panel flanges.
10. Use a lubricant on top of the roof curb is recommended to ease friction from lateral movements when securing sections.

Suggested Tools

- Two chain come-alongs. These have the pulling power to bring the shipping splits together, one on each side of the unit. Cable come-alongs are not strong enough and normally will fail. The chain versions work well.
- Two long drift pins to keep holes aligned as the sections come together.
- One half-inch or 3/4-inch electric impact gun. These are very effective to tighten the bolts at the base once it's close enough together to get the bolts in.
- Caulk guns.
- Standard battery impact gun or battery drill for installation of screw in joint strips, hubcaps, and inlet or exhaust hoods.
- Nut setters for battery impact gun - 3/8-inch and 5/16-inch.
- Utility knives for cutting section-to-section gasket.
- A couple of large pry bars.
- Proper size sockets and wrenches to remove lifting lugs when in positions. Multiple size sockets. Must have 15/16-inch and 1 1/16-inch sockets.

Installation - Mechanical

Lifting and Rigging

General Lifting Considerations

⚠ WARNING

Risk of Unit Dropping!

Failure to follow instructions below could result in death or serious injury, and equipment damage. Inspect the suspension and/or support system to ensure all fasteners are tight and the unit is secure before working underneath the unit.

⚠ WARNING

Improper Unit Lift!

Failure to properly lift unit could result in unit dropping and possibly crushing operator/technician which could result in death or serious injury, and equipment or property-only damage. Test lift unit approximately 24 inches to verify proper center of gravity lift point. To avoid dropping of unit, reposition lifting point if unit is not level.

NOTICE

Equipment Damage!

Premature skid removal could result in equipment damage. **Keep skid in place until unit is ready to set. Do not move the unit or subassembly without the skid in place as shipped from the factory.**

Before preparing the unit for lifting, estimate the approximate center of gravity for lifting safety. Because of placement of internal components, the unit weight may be unevenly distributed, with more weight in the coil and fan areas. Refer to the unit submittals for section weights. Test the unit for proper balance before lifting.

For outdoor air handlers, preparation of the roof curb or pier mount and roof openings must be completed before lifting to the roof. Refer to curb manufacturer's installation instructions for more details.

⚠ WARNING

Heavy Objects!

Failure to follow instructions below or properly lift unit could result in unit dropping and possibly crushing operator/technician which could result in death or serious injury, and equipment or property-only damage.

- Equipment is top heavy. Use caution when lifting/moving equipment to prevent unit from tipping.
- Ensure that all the lifting equipment used is properly rated for the weight of the unit being lifted. Each of the cables (chains or slings), hooks, and shackles used to lift the unit must be capable of supporting the entire weight of the unit. Lifting cables (chains or slings) may not be of the same length. Adjust as necessary for even unit lift.
- The high center of gravity on this unit requires the use of an anti-rolling cable (chain or sling). To prevent unit from rolling, attach cable (chain or sling) with no tension and minimal slack around compressor suction pipe as shown.
- Do not use forklift to move or lift unit unless unit has lifting base with it.

See unit submittal drawings for correct placement of sections. Always rig subassemblies or sections as they ship from the factory. Never bolt sections together before rigging.

- Lift all sections individually using **all** lifting lugs provided. See specific instructions for handling the pipe cabinet if shipped separately ("[Hoods and Pipe Cabinets](#)," p. 13).

Figure 3. Recommended attachment to lifting lugs.

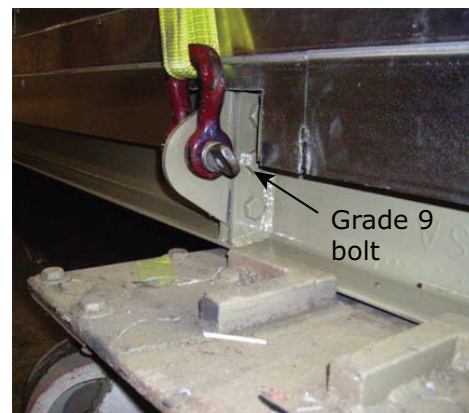

Figure 4. Use proper lifting and rigging methods



- When hoisting the unit into position, use the proper rigging method, such as straps, slings, spreader bars, or lifting lugs for protection and safety.
- Make the loop of the sling parallel to the direction of airflow whenever possible.
- Each of the cables used to lift the unit must be capable of supporting the entire weight of the unit.
- The air handler is not designed to be lifted, rigged or ceiling suspended from the top of the unit.
- Never lift units in windy conditions. Personnel should be positioned overhead and on the ground to guide the crane or helicopter operator in positioning the sections.
- Never stack the pipe cabinet and inlet hoods on the unit as the unit is being lifted.
- Do not attach the intake/exhaust hoods to the unit prior to lifting the unit. Doing so may damage the equipment. Attach the hoods to the unit only after all sections are in place.
- Remove all wooden blocks before installing the unit to the roof curb.
- All shipping supports and crating on the face of the sections must be removed to permit proper fit-up and sealing of the surfaces. Dispose of properly.

Hoods and Pipe Cabinets

⚠ WARNING

Risk of Unit Dropping!

Failure to follow instructions below could result in death or serious injury, and equipment damage. Inspect the suspension and/or support system to ensure all fasteners are tight and the unit is secure before working underneath the unit.

When hoisting inlet and exhaust hoods into position, use the proper rigging method such as straps, slings, or spreader bars for protection and safety. Inlet and exhaust hoods will either ship inside the unit if space permits, or separately on a wooden pallet. Separately shipped hoods should be hoisted separately from the unit. Hoods inside the unit may be hoisted while inside the shipping section, as long as they are secured for the lift such that they cannot shift and slide out.

Figure 5. Lifting pipe cabinets

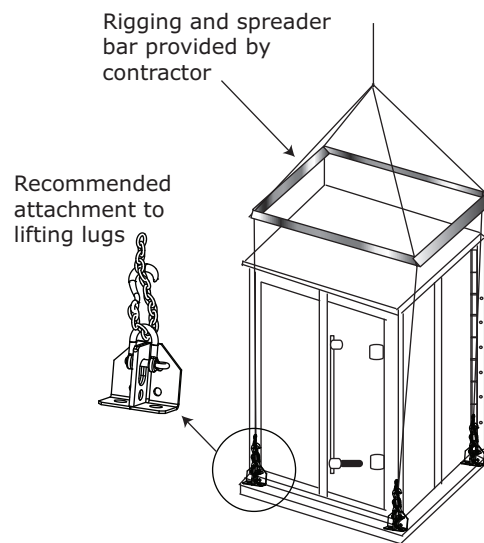

Unit Placement and Assembly

If the air handler ships in subassemblies or in individual sections, some assembly is required.

Prior to unit assembly, refer to the unit submittal drawings and unit tagging for correct placement of sections. Failure to review the submittal drawings could result in performance or assembly problems. If there are any discrepancies, contact your local Trane sales representative before proceeding.

Provide clearance around the unit to allow adequate free air and necessary service access. Also, allow room for supply and return piping, ductwork, electrical connections, and coil removal.

Unit Placement

⚠ WARNING

Risk of Roof Collapsing!

Failure to ensure proper structural roof support could cause the roof to collapse, which could result in death or serious injury and property damage. Confirm with a structural engineer that the roof structure is strong enough to support the combined weight of the roof curb, the unit, and any accessories.

⚠ WARNING

Risk of Unit Dropping!

Failure to follow instructions below could result in death or serious injury, and equipment damage. Inspect the suspension and/or support system to ensure all fasteners are tight and the unit is secure before working underneath the unit.

NOTICE

Microbial Growth!

Failure to follow instructions below could result in odors and damage to the equipment and building materials. The floor or foundation must be level and the condensate drain at the proper height for proper drainage and condensate flow. Standing water and wet surfaces inside the equipment can become an amplification site for microbial growth (mold). If there is evidence of microbial growth on the interior insulation, it should be removed and replaced prior to operating the system.

Removing the Shipping Skid

If a unit arrives in sections, then each section must be individually hoisted, set on the housekeeping pad, roof curb, or pier mount and then assembled.

Following the order of the sections on the unit submittals and tagging, individually place each unassembled section or subassembly in the appropriate installation location.

Note: Prior to placing fan section in the appropriate installation location, verify shipping tie-downs have been removed.

For outdoor units, the pipe cabinet must also be mounted as an individual section. Refer to "Pipe Cabinet," p. 28 for specific instructions.

When mounting the unit on a roof curb, make sure the gasketing between the roof curb and unit base provides an airtight seal.

When mounting the unit on a pier mount, locate one pier at each corner as a minimum, directly underneath any shipping split (ensure full support under each side) and then every four feet at equally spaced intervals around the perimeter of the

unit. Both the unit and the pipe cabinet should be supported by their base around the entire perimeter. See Figure 6 and Figure 7.

Figure 6. Piers located in each corner and spaced evenly every four feet

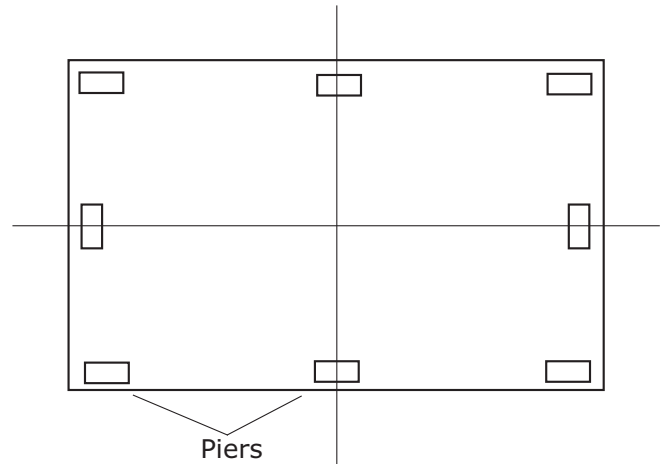

Note: Piers beneath shipping splits must be structurally sound to support the weight of the unit.

Figure 7. Side view with two shipping splits - locate one pier directly under each shipping split

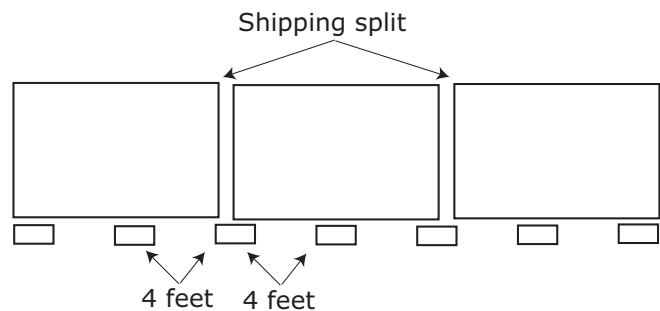

Note: Piers beneath shipping splits must be structurally sound to support the weight of the unit.

For proper operation, the unit must be installed level (zero tolerance) in both horizontal axes. For vertical discharge units, allow space under the unit for supply air ductwork connections.

Unit Assembly

Note: Air handlers often include optional factory-provided casing penetration entry points for field-provided wiring. Consider overall unit serviceability and accessibility before mounting, running wires (power), making cabinet penetrations, or mounting any components to the cabinet.

Ceiling Suspension

⚠ WARNING

Risk of Unit Dropping!

Failure to follow instructions below could result in death or serious injury, and equipment damage. Inspect the suspension and/or support system to ensure all fasteners are tight and the unit is secure before working underneath the unit.

Using a Field-Provided Mounting Frame

If a field-provided mounting frame is used for ceiling suspension, the installer/contractor must provide a ceiling-suspended mounting frame designed to support the length, width, and weight of the entire air-handling unit. See submittal for weights.

Note: *It is the building engineer's responsibility to size the structural channels and to provide the appropriate hangers.*

Structural channels in a field-provided frame can be mounted parallel to airflow or perpendicular to airflow:

- For parallel-to-airflow channels, size channels based on a four-point load distribution (see [Figure 8](#)).

Figure 8. Typical suspension method-parallel channels

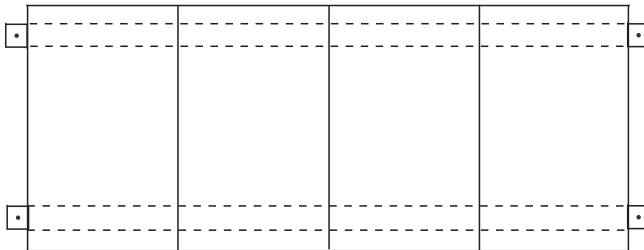

- For perpendicular-to-airflow channels, size channels based on the load distribution of the individual sections and install the channels so that *both ends of every section are supported* (see [Figure 9](#)).

Figure 9. Typical ceiling suspension-perpendicular channels

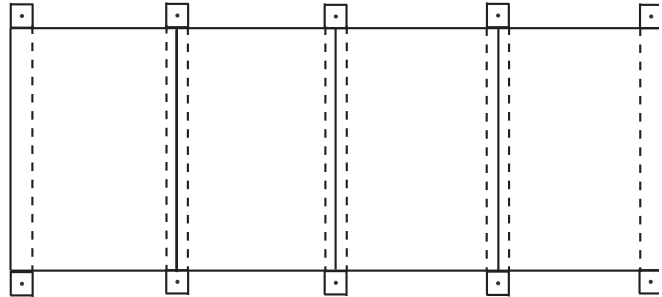

⚠ WARNING

Toxic Fumes!

Keep open flame away from unit exterior or interior. Do not weld or use cutting torch on the exterior or interior of the unit. The unit contains polyurethane insulation. Flame could produce toxic gas which could result in death or serious injury.

NOTICE

Equipment Damage!

Failure to comply with temperature requirements could result in equipment damage. The internal sections of this unit containing electrical components must not exceed 104° F operating temperature. Internal sections of the unit which do not contain electrical components must not exceed 200° F temperature.

Assembly Instructions

The base is constructed for specific installation requirements such as standard roof curbs, structural support curbs, steel I-beam dunnage support, and pier mounting.

⚠ WARNING

Risk of Roof Collapsing!

Failure to ensure proper structural roof support could cause the roof to collapse, which could result in death or serious injury and property damage.

Confirm with a structural engineer that the roof structure is strong enough to support the combined weight of the roofcurb, the unit, and any accessories.

Standard Roof Curb

The unit exterior base channel is constructed to overhang the roof curb. Unit support is provided by a square tube channel locate inside of exterior base channel. The standard curb should be designed to properly support the unit's weight without bow and sized to fit within the perimeter base channel.

Figure 10. Standard roof curb

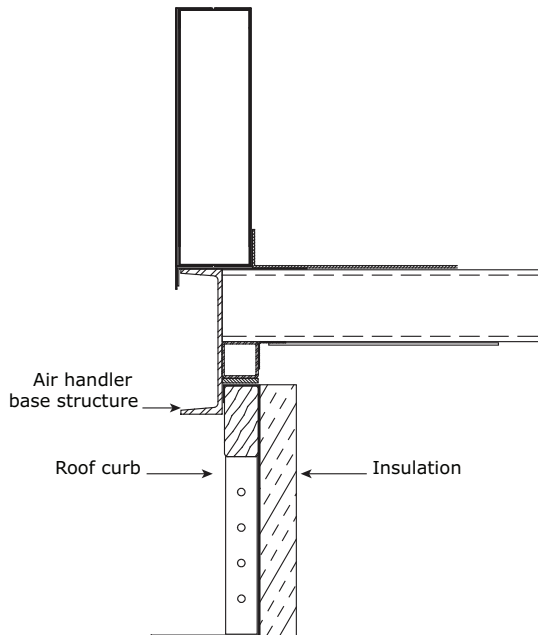

For large units shipped in sections, see additional requirements in "Roof Curb for Large Unit with Shipping Splits," p. 17

Structural Roof Curb and I-Beam Dunnage

The base for structural roof curbs (Figure 11) and I-beam dunnage (Figure 12) are designed to sit directly onto unit support with no overhang. The structure should be designed to properly support unit weight without bow and sized to the unit's perimeter exterior base channel.

For large units shipped in sections, see additional requirements in "Roof Curb for Large Unit with Shipping Splits," p. 17.

Figure 11. Structural roof curb

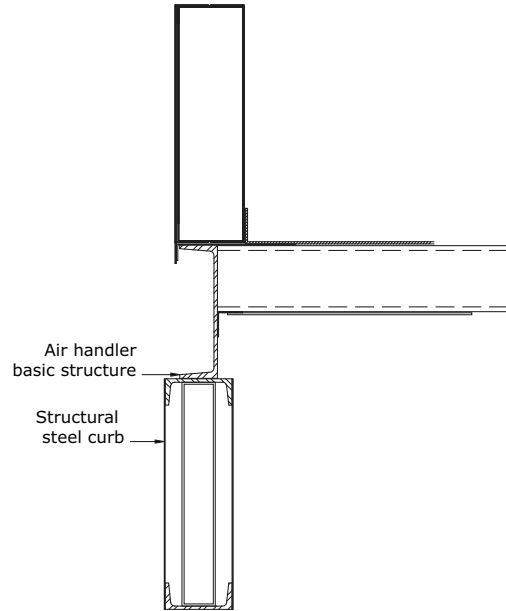
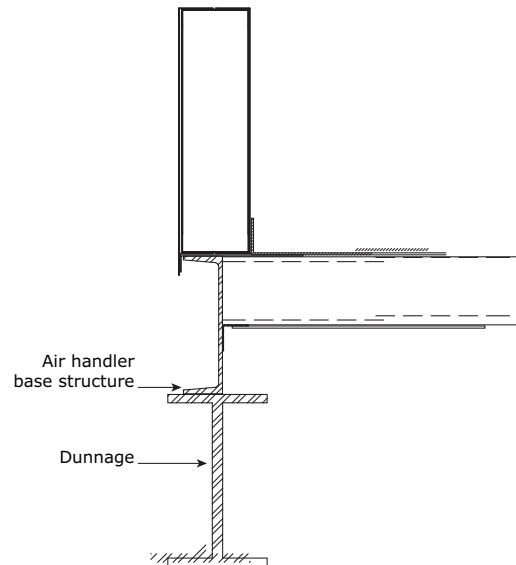

Figure 12. I-beam dunnage mount



Seismic restrictions will require the use of welding or fasteners to secure unit to roof curb. Please refer to submittal package for guidelines

All section perimeters must be continuously supported. Failure to may result in door misalignment, leakage, and incorrect or non-functioning drain pan operation.

Flat Concrete Pad

The base for concrete is designed to sit flat on the concrete with full perimeter contact. Concrete pads should be perfectly level, flat, and sized to the minimum exterior base channel measurements.

Figure 13. Flat concrete pad mount

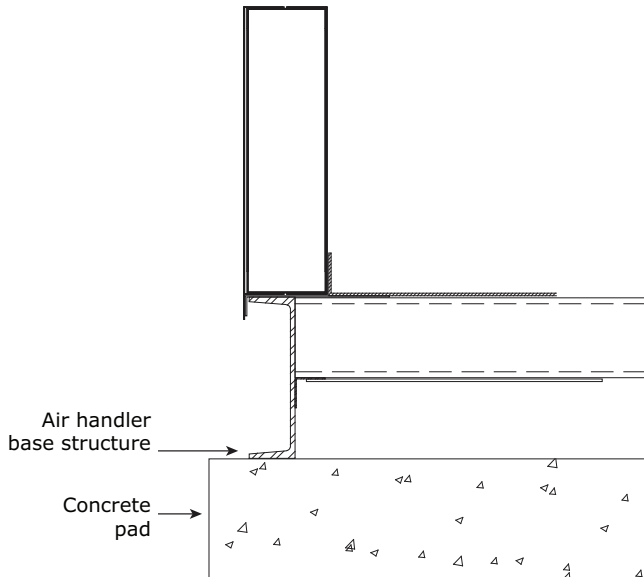

Roof Curb for Large Unit with Shipping Splits

Larger units with shipping splits may require full-width intermediate support. With any raised type roof support such as curbs or dunnage, provisions must be made to carry the weight of the base cross members at the sectional splits. Since these unit bases are designed with lifting lugs between the sections, temporary support must be provided so additional sections can be set down with a 12-inch gap to allow for working room between sections and lug removal. The use of field-provided outriggers has proven to be a successful way to accomplish this. Large units may require additional metal in the roof curb. This is to ensure the long span of perimeter unit structural support will slide over and rest on the roof curb. Please call factory for clarification if needed. See [Figure 14](#).

Figure 14. Field-supplied outriggers

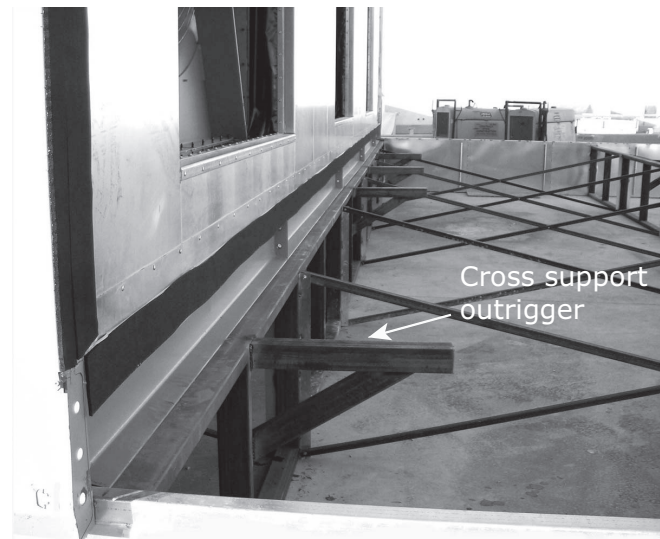

Joining Sections Edge-to-Edge

Units must be installed level for proper drainage of condensate from the drain pan. In addition, each section in a multi-section unit must be properly supported.

Note: *Leveling each section, beginning with the first, is critical. Failure to level and align the sections immediately creates greater misalignment or even structural damage afterward.*

1. Remove all crating and wrapping from the surfaces to be joined.
2. Place one section of the air handler into the desired position. Verify section is installed level front to back and side to side. Verify section is square to support structure, this is critical to insure proper alignment for next adjoining sections.
3. Check squareness measuring the critical dimensions given. Use preselected method to anchor first piece in place. This is necessary so movement will not affect pulling next sections into alignment.
4. When the unit is positioned and squareness is ensured within 1/8-inch, remove all lifting lugs located along the split plane.
5. After assuring positioning is correct, anchor in place either by welding unit base to the curb or by mechanical fasteners. The first section will be used to pull remaining sections up tight so it's critical that first section be secured.
6. Install 2-inch to 4-inch x 1/4-inch neoprene gasket, depending on casing thickness, to all mating surfaces of the section, including any internal walls. This gasket must be applied to the full perimeter of the section split on both sections to be joined.
7. Move the next mating section into alignment with the positioned section. Alignment of sections must be completed before gasket surfaces meet. The two sections

Installation - Mechanical

should be within 12 inches to reduce the amount of dragging required.

8. Remove lifting lugs on mating section as required. The nuts and bolts from the lifting lugs should be used to attach the sections together.
9. Pulling sections together on a flat surface can be done by using chain come-alongs hooked onto the welded pull tubes located on each side of the shipping split. These square tubes are designed to fully support the stress of pulling sections together. Pulling the unit evenly on both sides will ensure connecting plates will line up. Sections should be pulled together until mating gaskets make contact and factory-supplied bolts can be installed in connecting plate.

Figure 15. Insert supplied bolts through each hole of mating connecting plate.

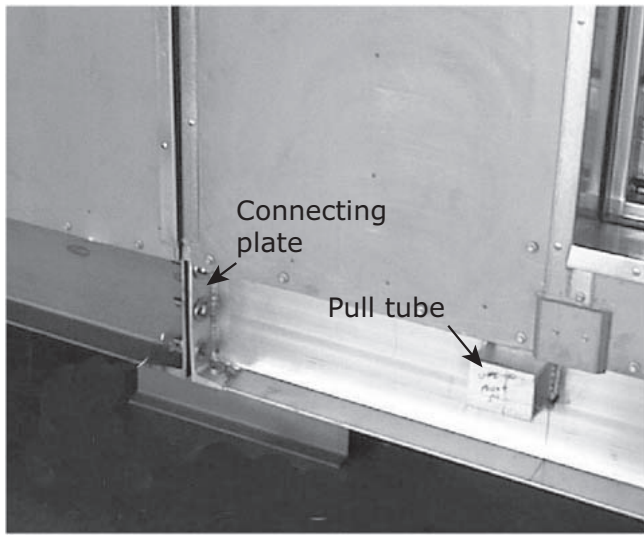

10. When sections are close enough to allow full threading of the factory-supplied nut onto the bolt, chain come-alongs can be removed. The use of an electric impact gun to tighten bolts in a sequential manner will allow the additional section to be pulled into the final position.

11. Check overall unit length to assure proper joint compression.

Note: Failure to compress the gasketing may result in air leakage.

12. Once the sections are pulled together, install the assembly hardware as applicable for the walls, roof, and the base as demonstrated in the following assembly sections.

Base with Flat Floor

Note: Corner gussets are to ensure unit squareness during shipping, lifting, and assembly. Please remove, when unit is set in place.

Note: Failure to completely compress the gasketing may result in air leakage.

1. Join the two units and secure with factory-provided 5/8-inch flat washers and 5/8-inch X 2-1/2-inch grade 9 bolts through each of the six holes.
2. Caulk the overlapping flange along the length of each split to maintain a seal.

Note: Use a polyurethane or equivalent caulk.

3. Before installing the pre-cut 4-inch 18-gauge joining strips, pre-drill holes in the floor using the 4-inch strip as a guide with a 7/32-inch drill bit at 12-inch centers.
4. After holes are pre-drilled, apply an ample bead of caulk to the joint then install 4-inch strip with #14 sheet metal screws uniformly straddling the split.
5. In cases of tread plate floor, some job specifications may call for the seam to be welded. In those cases make sure the sections are pulled together tightly then weld with appropriate method. The floor construction in those cases will be such that the heat from welding will not affect the insulation.

Figure 16. Base assembly with flat floor

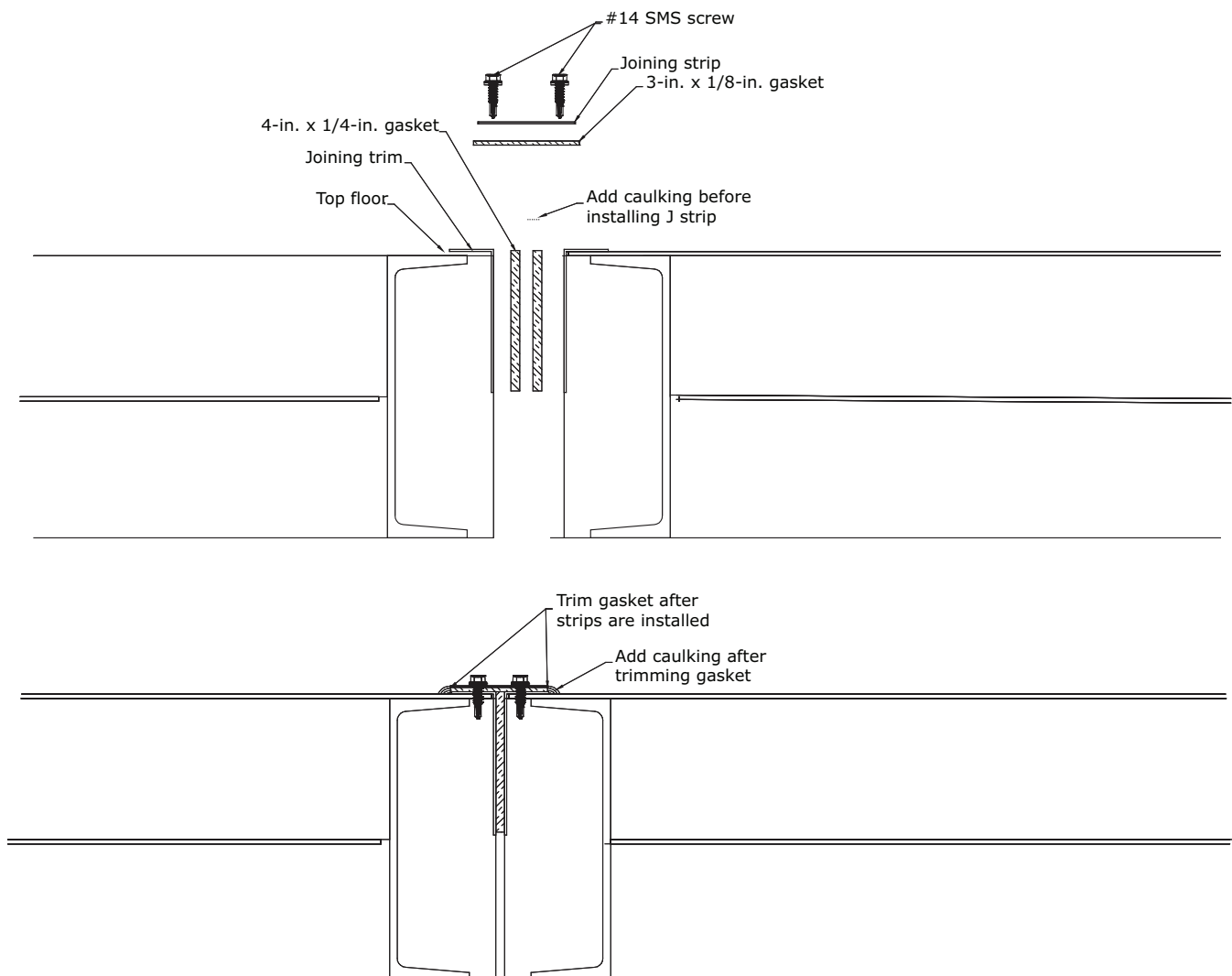

Base with Turned-Up Floor

Note: Corner gussets are to ensure unit squareness during shipping, lifting, and assembly. Please remove, when unit is set in place.

1. Apply 4-inch x ¼-inch neoprene gasket to the full perimeter face of each shipping split section.
2. Join the two sections and secure with field-provided 5/8-inch flat washers and 5/8-inch x 2 ½-inch grade 9 bolts through each of the six holes.
3. Apply a heavy bead of caulk to the inside of the U-channel.

Figure 17. Add caulk to U-channel

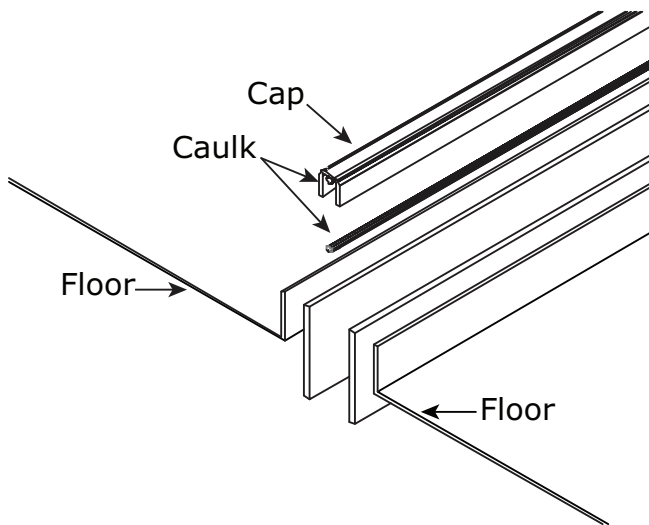

4. Press U-channel down over upturned flanges with moderate pressure to ensure it is fully seated onto upturned flanges. The caulk will cure and act as an adhesive to hold U-channel in place, no fasteners are required.

Figure 18. Press U-channel in place

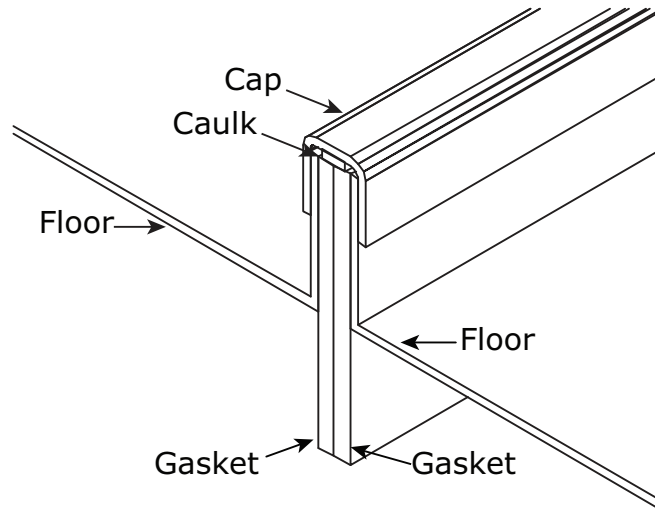

Walls

Exterior Wall

1. Ensure shipping split sections are aligned and pulled together properly.
2. Apply a bead of caulk to full height of wall joint.
3. Apply 3-inch x 1/8-inch adhesive-backed foam gasket to inner joining strip.
4. Install inner joining strip using #14 x 1.5-inch gasketed TEK® screws.
5. Fit the pre-cut hub cap over the joining strip the vertical height of the wall flush with the roof and secure it to the wall with # 8 sheet metal screws. Fill the top and bottom

openings with caulk as a moisture seal. Screw holes can be pre-drilled with a #29 bit.

Interior Wall and Roof Joint

Note: *Corner gussets are to ensure unit squareness during shipping, lifting, and assembly. Please remove, when unit is set in place.*

1. Ensure shipping split sections are aligned and pulled together properly.
2. Pre-drill interior joining strip screw holes using #29 drill bit.
3. Apply a bead of caulk the full height of interior wall joint.
4. Install joining strips using #10 sheet metal screws.

Figure 19. Wall section assembly

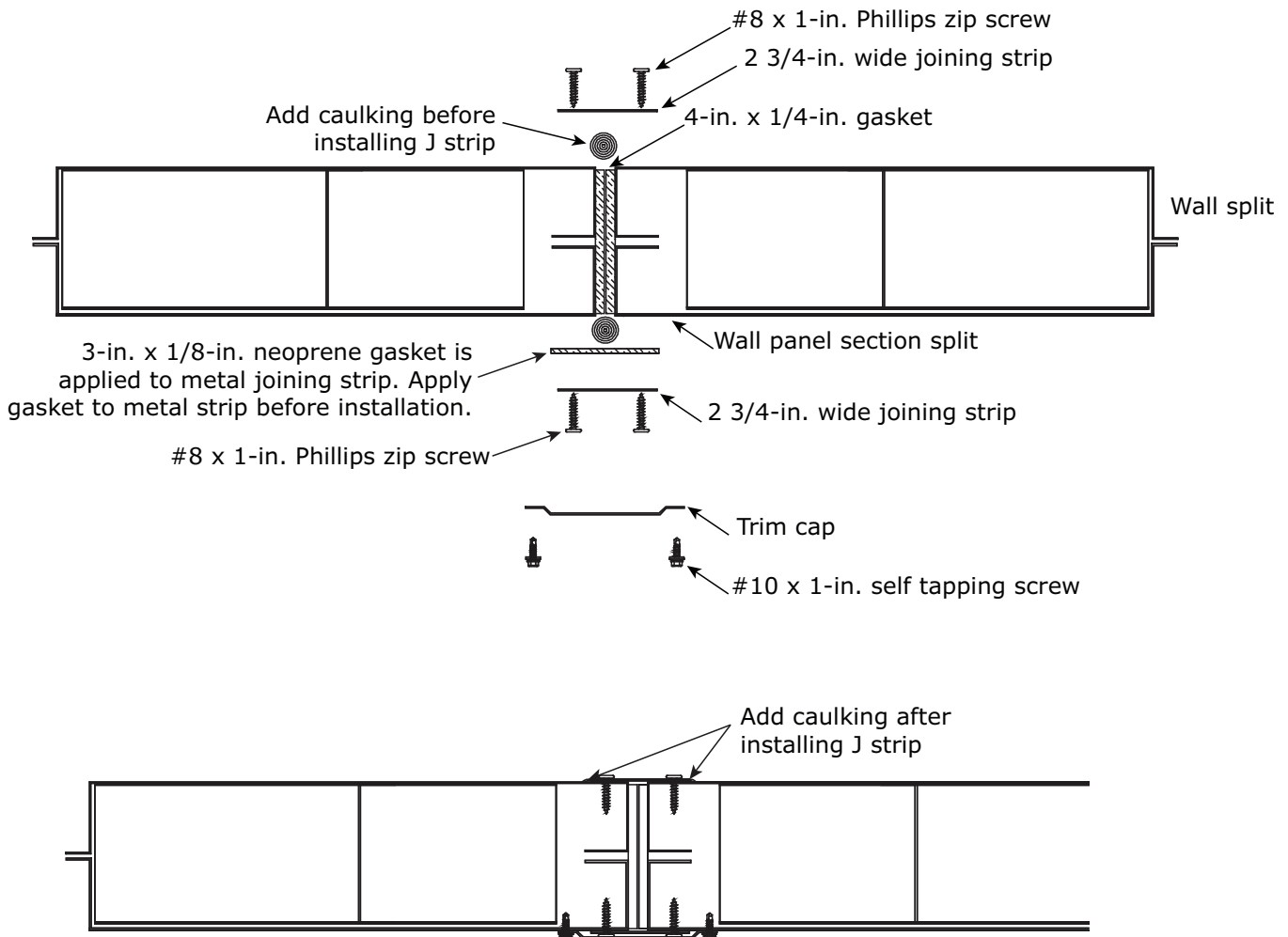

Figure 20. Section split - indoor

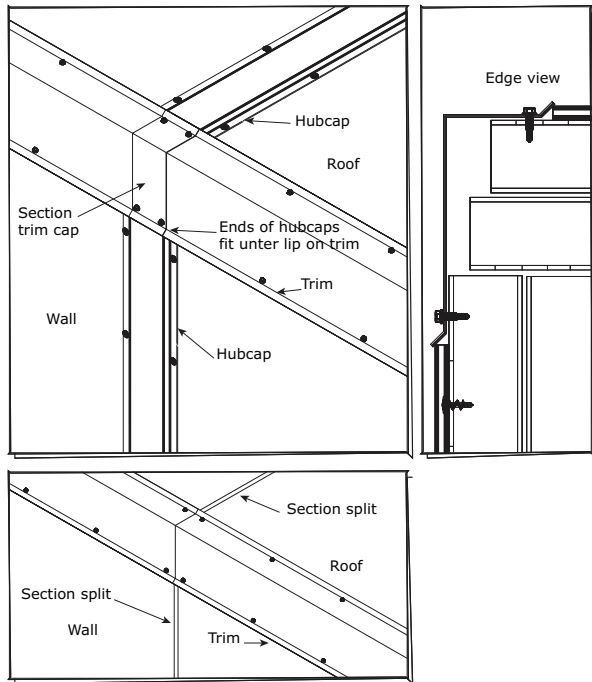
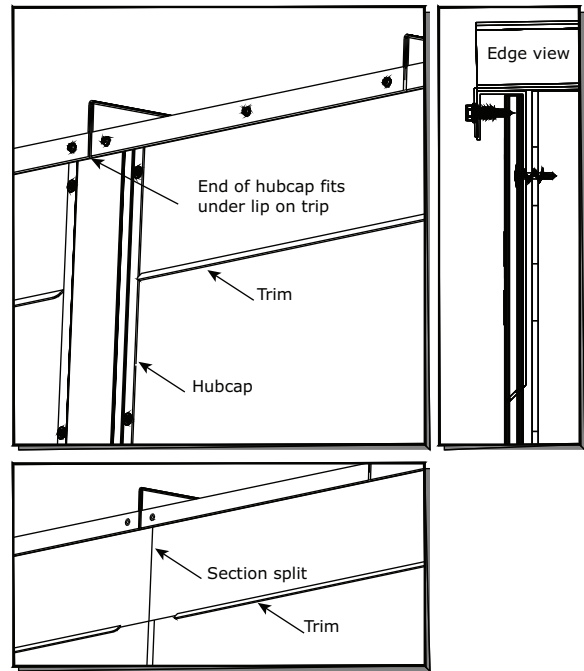

Figure 21. Section split - outdoor



Outdoor Roof - Single Span

1. Ensure shipping split sections are aligned and pulled together properly.
2. Add a bead of caulk along the length of the roof seams. Install the pre-cut J-cap over the seam and secure with #14 sheet metal screws on 12-inch centers.

Note: Use a polyurethane or equivalent caulk. It may be necessary to clamp the joint together or pre-drill to prevent separation when drilling with screws.

3. Apply caulk to end of J-cap to seal thoroughly.

Figure 22. Outdoor roof assembly - single span

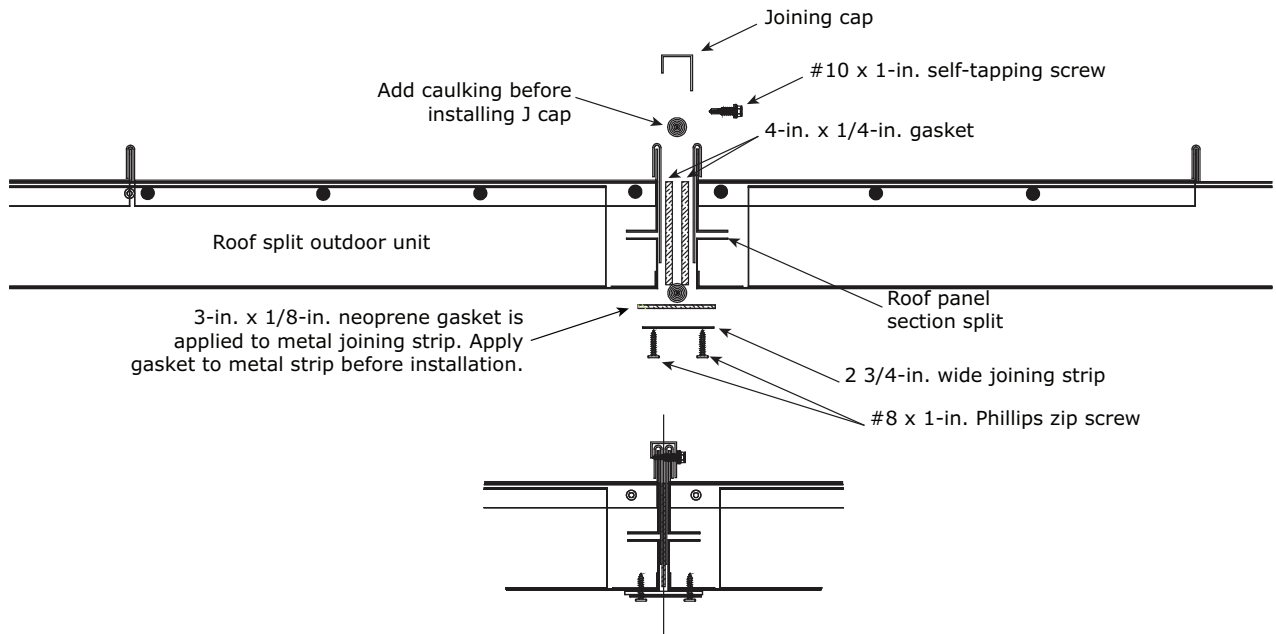

Outdoor Roof - Multiple Span

Follow instructions in [Figure 22](#) for installation of J-Caps.

1. The multiple roof split requires an additional cap that covers the center T-shaped seam running parallel to air flow.
2. Install #14 self drilling screws on 10-inch centers on underside of center split as shown in [Figure 23](#).
3. Apply a bead of caulk to the seam the full length that roof cap will cover.

4. Apply 3-inch x 1/8-inch adhesive-backed neoprene gasket to underside of roof cap.
5. Install roof cap using #10 sheet metal screws in pre-punched holes.
6. Apply a bead of caulk over the butt joint where roof caps meet.
7. Install roof cap trim piece at joint of each roof cap using #10 sheet metal screws.

Figure 23. Outdoor roof assembly - multiple span

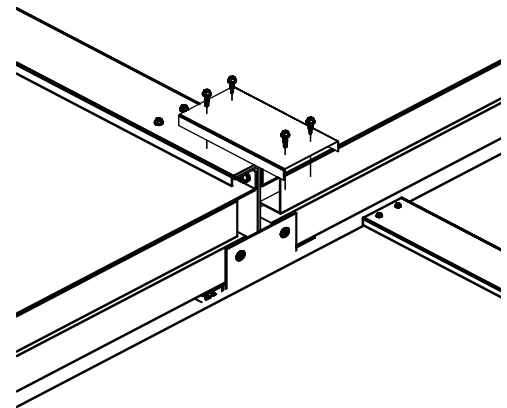
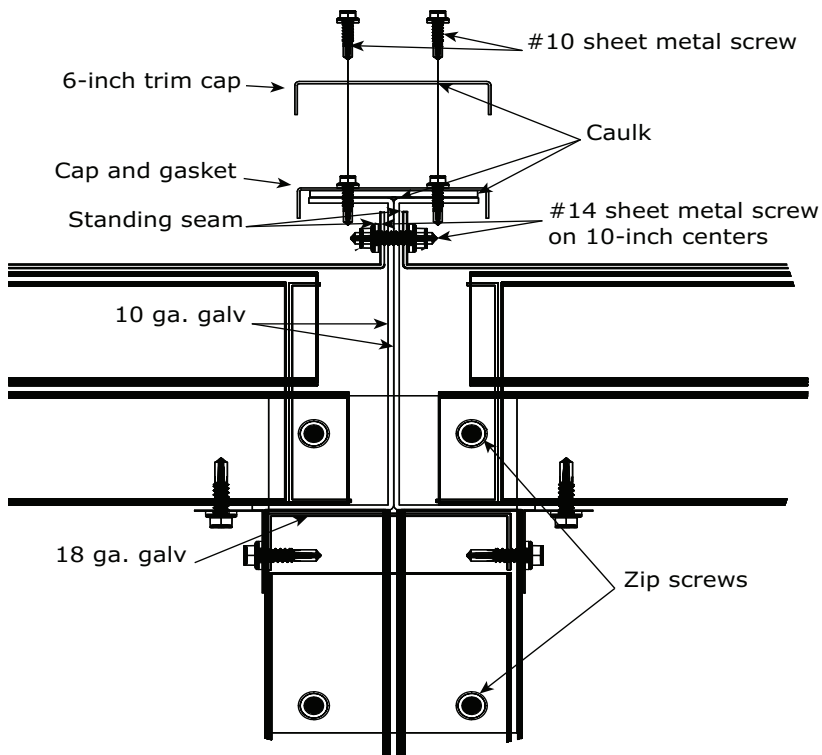

Indoor Roof

Note: Corner gussets are to ensure unit squareness during shipping, lifting, and assembly. Please remove, when unit is set in place.

1. Ensure shipping split sections are aligned and pulled together properly.
2. Apply a bead of caulk to full height of wall joint.
3. Apply 3-inch x 1/8-inch adhesive-backed foam gasket to inner joining strip.

4. Install inner joining strip using #14 x 1.5-inch gasketed TEK® screws.
5. Fit the pre-cut hub cap over the joining strip the vertical height of the wall flush with the roof and secure it to the wall with #8 sheet metal screws.
6. Fill the top and bottom openings with caulk as a moisture seal. Screw holes can be pre-drilled with a #29 bit.
7. Apply a bead of caulk over top corner of cap seam.
8. Using #10 sheet metal screws, attach corner seam trim cap as shown in [Figure 24](#).

Figure 24. Indoor wall and roof assembly - trim cap

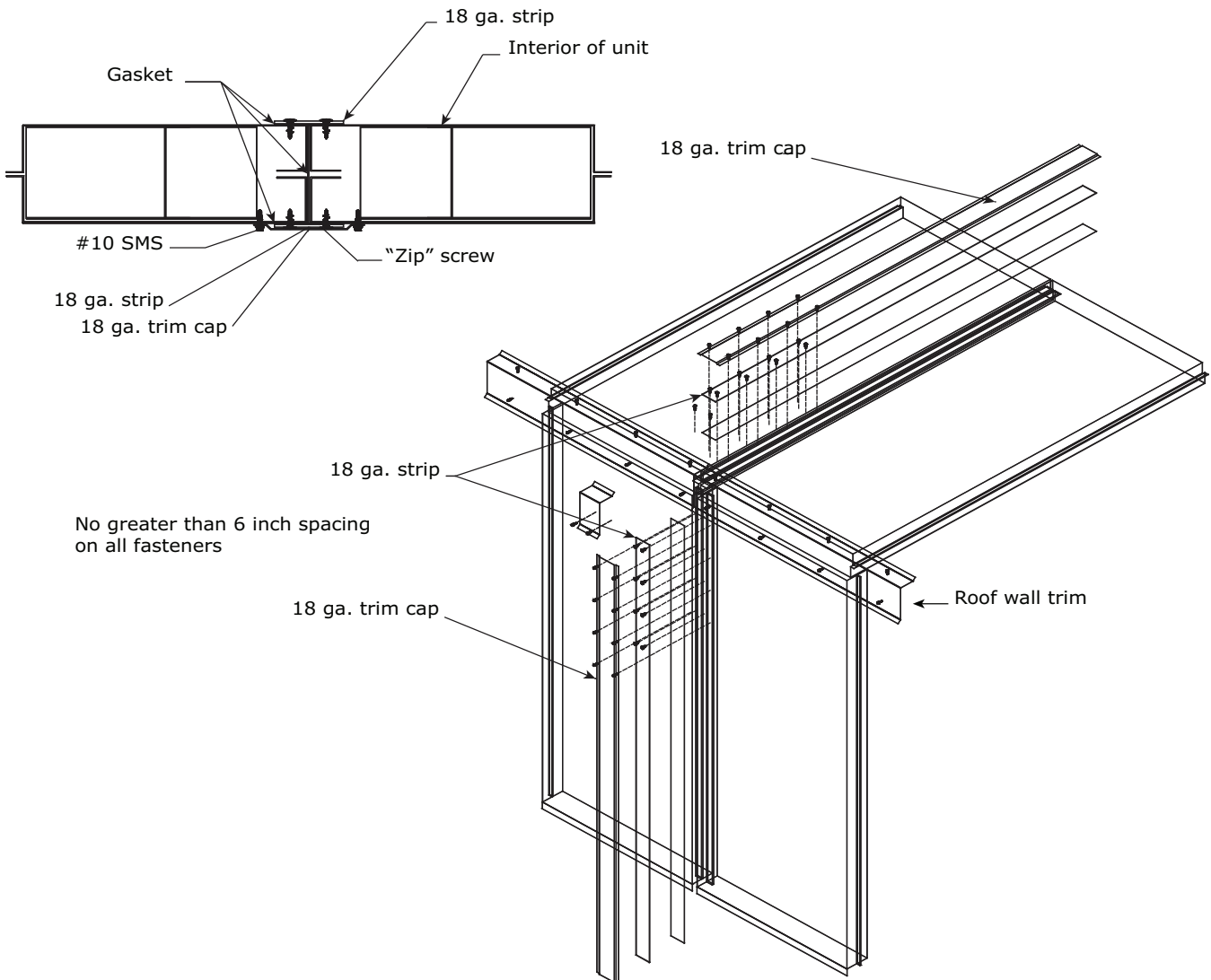

Indoor Roof - Multiple Span

1. Ensure shipping split sections are aligned and pulled together properly.
2. Apply a bead of caulk to full height of wall joint.
3. Apply 3-inch x 1/8-inch adhesive-backed foam gasket to inner joining strip.
4. Install inner joining strip using #14 x 1.5-inch gasketed TEK® screws.
5. Fit the pre-cut hub cap over the joining strip the vertical height of the wall flush with the roof and secure it to the wall with #8 sheet metal screws.
6. Fill the top and bottom openings with caulk as a moisture seal. Screw holes can be pre-drilled with a #29 bit.
7. Apply a bead of caulk over top corner of cap seam.
8. Using #10 sheet metal screws, attach corner seam trip cap as shown in [Figure 25](#).

Figure 25. Indoor roof assembly - multiple span

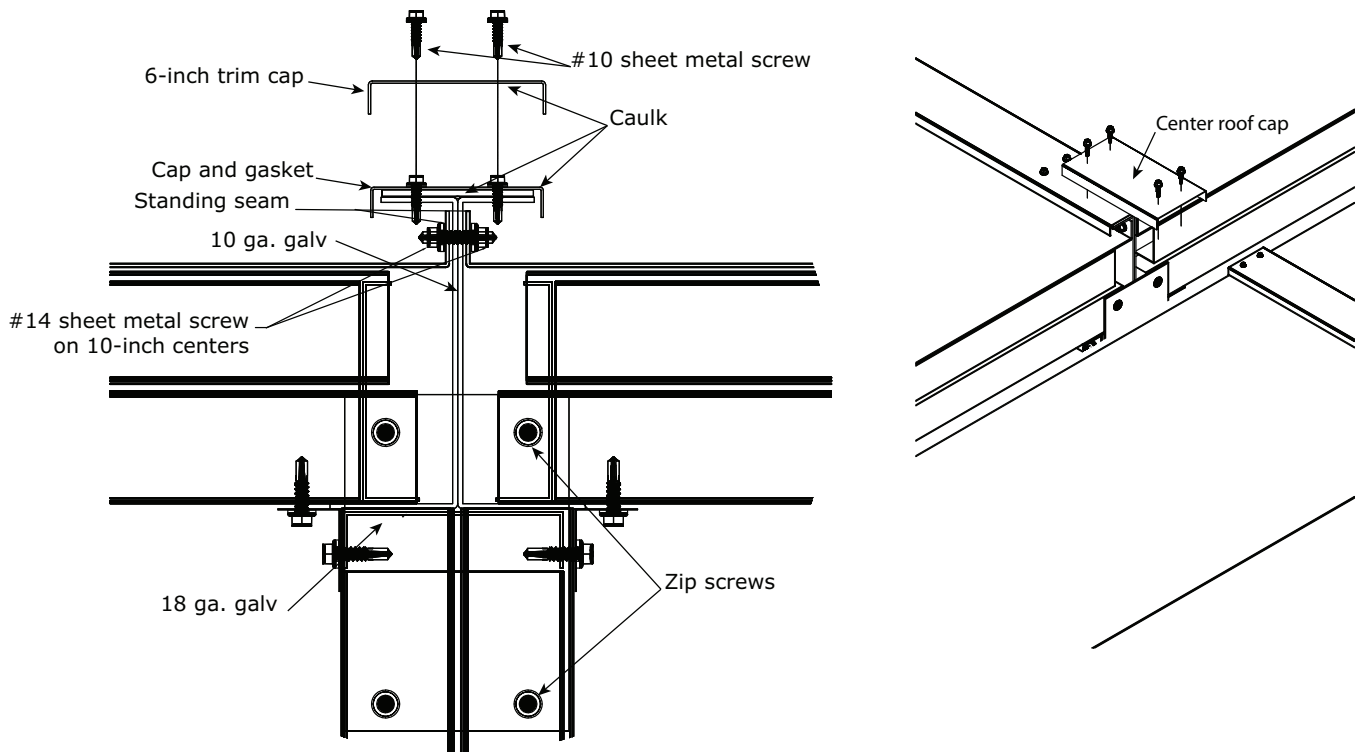

Base-to-Interior Wall

Note: Corner gussets are to ensure unit squareness during shipping, lifting, and assembly. Please remove, when unit is set in place.

Note: Failure to completely compress the gasketing may result in air leakage.

1. Join the two units and secure with field provided 5/8-inch flat washers and 5/8-inch X 2-1/2-inch grade 9 bolts through each of the six holes.

2. Apply caulk the length of the base between the 2-inch X 2-inch angle on the one base section and the wall on the adjoining section.

Note: Note: Use a polyurethane or equivalent caulk.

3. Secure the 2-inch X 2-inch angle to the adjoining wall with #14 sheet-metal crews on 12-inch centers along the length of the angle and wall.

Figure 26. Base-to-interior wall sections

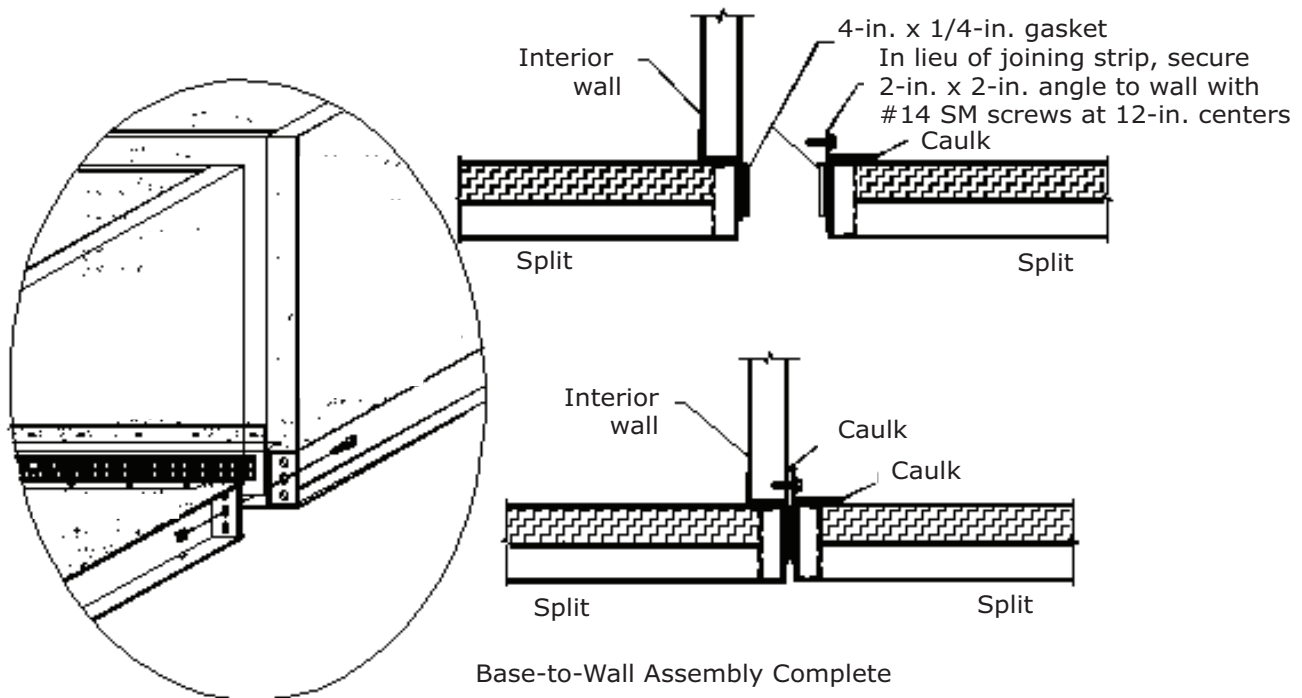

Stacked Unit

1. Install and assemble all lower sections as described in typical assembly.
2. Lift first piece of upper section into place assuring proper alignment with lower unit.
3. Install 10 gauge 12-inch angle clips as shown in Figure 27 and secure with grade 5 self-tapping screws placed 4-inches on center.

4. Lift next upper piece into place and secure shipping split with appropriate hardware then anchor to lower section as described above.
5. Continue until all sections are installed and anchored properly.
6. Install the 18-gauge cover trim cap using #10 self drilling screws.

Figure 27. Stacked unit trim assembly

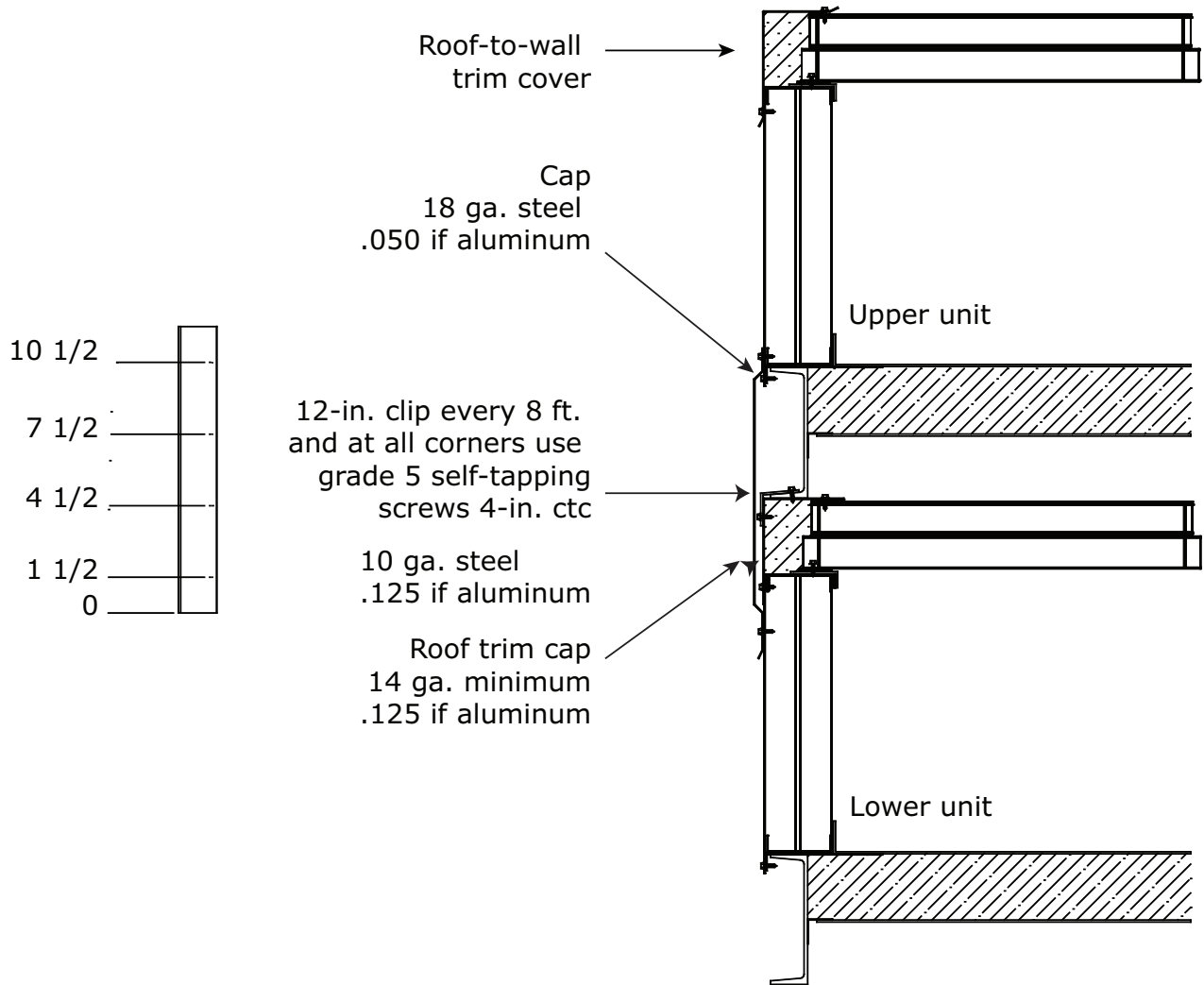

Pipe Cabinet

Figure 28. Pipe cabinet installation

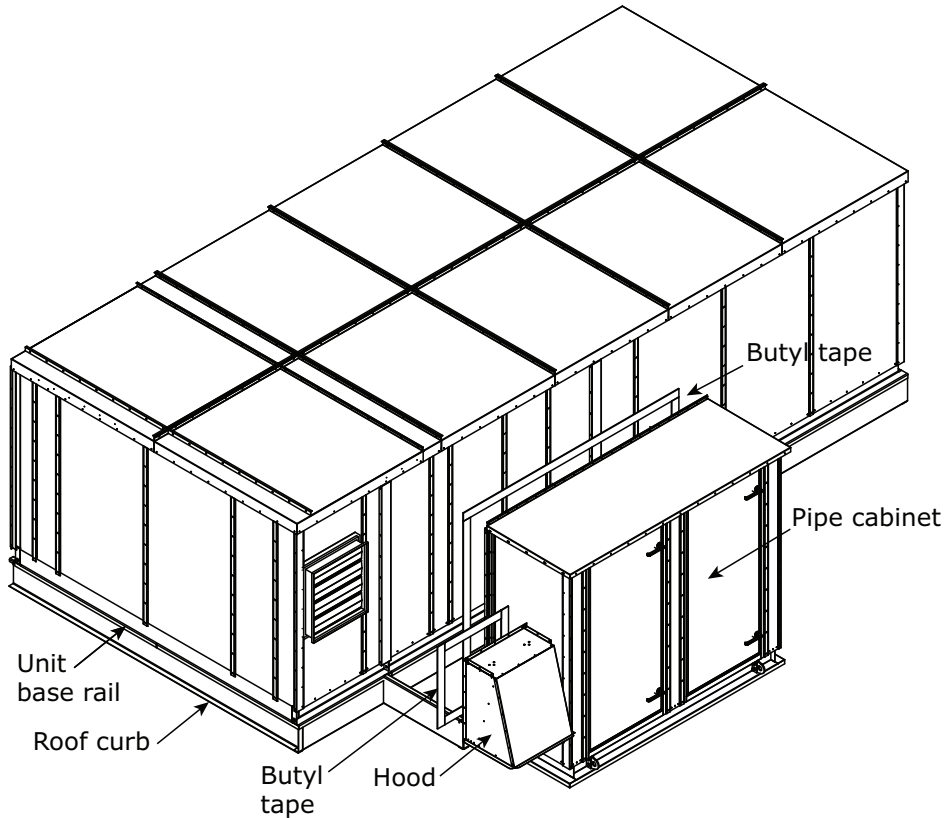

1. After air handler is completely installed and checked for accuracy of level and square, pipe cabinet install can begin.
2. Remove bolts holding the lifting lugs in place from the base of the air handler.
3. Check to ensure that the structure the pipe cabinet is to be installed on is square and level.
4. Install 3/16-inch x 1.25-inch grey ribbed butyl tape to flanged side of pipe cabinet wall and remove paper backing from tape.
5. Lift cabinet into place aligning base tab with lifting lug brackets on air handler base.
6. Slide pipe cabinet tight up against mounting channels on side wall of air handler.
7. Install bolts through lifting lug gussets to anchor pipe cabinet base to the air handler.

Figure 29. Anchor pipe cabinet to base

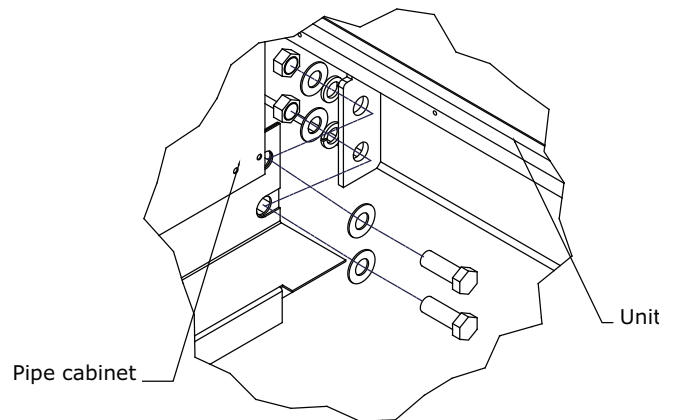

11. Install 3/16-inch x 1.25-inch grey ribbed butyl tape to unit

8. Check pipe cabinet side walls to ensure they are plumb.
9. Apply a bead of caulk along the corner between the pipe cabinet and air handler wall prior to installing connecting angle.
10. Install inside corner cap. See [Figure 30](#) Detail A and B. wall where pipe cabinet roof connects.

Component Installation Requirements

12. Lift pipe cabinet roof into place and attach to unit wall with screws.

Figure 30. Pipe cabinet detail

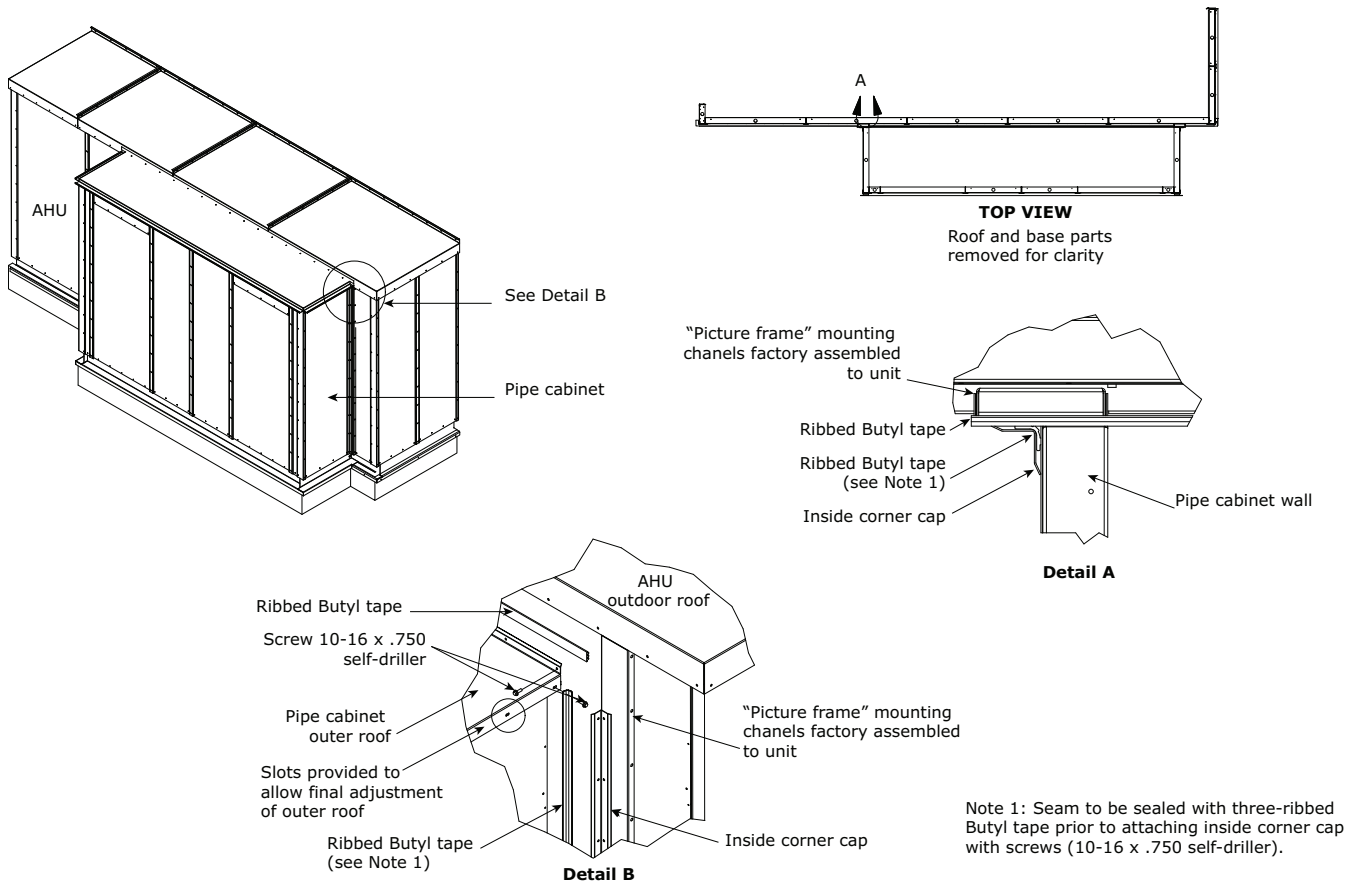

Component Installation Requirements

⚠ WARNING

Hazardous Voltage w/Capacitors!

Failure to disconnect power and discharge capacitors before servicing could result in death or serious injury.

Disconnect all electric power, including remote disconnects and discharge all motor start/run capacitors before servicing. Follow proper lockout/tagout procedures to ensure the power cannot be inadvertently energized. For variable frequency drives or other energy storing components provided by Trane or others, refer to the appropriate manufacturer's literature for allowable waiting periods for discharge of capacitors. Verify with a CAT III or IV voltmeter rated per NFPA 70E that all capacitors have discharged.

Each component in the Custom air handler may have installation requirements that could affect the unit's performance.

Note: For components included in the unit but not included in this manual, reference the component manufacturers specific *Installation, Maintenance, and Operation manual*. Copies of these manuals are either included in the package with this unit IOM or are attached to the components mounted in the unit.

Fan Section

The fan section can be configured as either draw-thru or blow-thru. Review the submittals and unit tagging information prior to assembly to determine placement.

⚠ WARNING

Hazardous Service Procedures!

Failure to follow all precautions in this manual and on the tags, stickers, and labels could result in death or serious injury.

Technicians, in order to protect themselves from potential electrical, mechanical, and chemical hazards, **MUST** follow precautions in this manual and on the tags, stickers, and labels, as well as the following instructions: Unless specified otherwise, disconnect all electrical power including remote disconnect and discharge all energy storing devices such as capacitors before servicing. Follow proper lockout/ tagout procedures to ensure the power can not be inadvertently energized. When necessary to work with live electrical components, have a qualified licensed electrician or other individual who has been trained in handling live electrical components perform these tasks.

Fan Isolation

If the fan-and-motor assembly is internally isolated, the fan and motor bases are bolted to a minimum of four spring isolators. The isolators are secured to the fan section support base.

Shipping tie-down bolts are bolted adjacent to the isolators between the fan isolation base and the isolator support frame. The shipping tie-downs secure the isolation base to the support assembly to prevent any damage to the fan section during shipment.

Note: Remove the tie-downs **only** if the factory-provided isolation is to be used.

Adjusting the Isolators

Note: Isolators are pre-adjusted and set at the factory. Follow this procedure only if necessary and as it applies to the isolators used in this unit. This procedure can and should be performed by one person to ensure that the proper sequence is followed.

Isolators are selected for distribution of equipment weight, but may not all compress the same. This procedure assumes the base surface is level. Isolators are not intended to be leveling devices.

1. Verify that the shipping bolts that hold the fan base in a fixed position have been removed. See [Figure 31](#).

Figure 31. Isolator

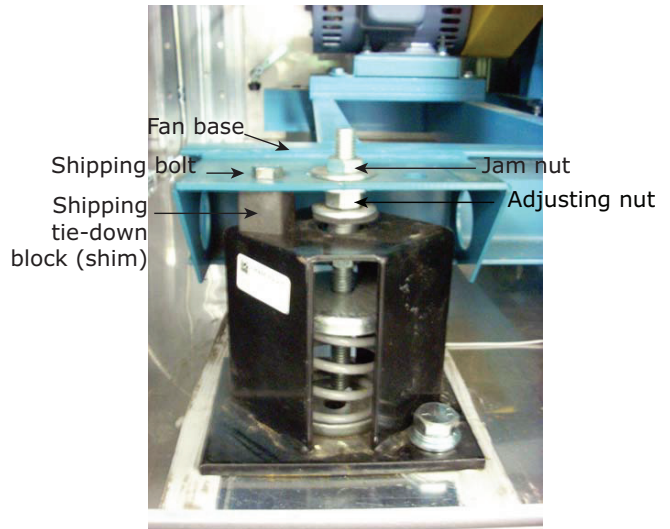

2. Remove the jam nut on top of the isolator adjusting stud at the first isolator to be adjusted. Check that the shipping block is in place.
 3. Turn the adjusting nut two or three turns only, counterclockwise on each isolator in a sequenced manner. The equipment weight will compress the spring inside the housing approximately 1/4 inch.
 4. Check that the bushing on the isolator stud is centered in the isolator. Adjust to center by moving the stud in the fan base hole.
 5. This procedure will raise the equipment load until the isolators are all off the shims (shipping tie-down blocks) approximately 1/32-inch (the thickness of a credit card), and the internal gap is approximately equal to the external gap.
- Note:** Do not adjust isolators once the fan base is off of the shipping tie down blocks.
6. Continue adjusting other isolators in sequence and repeat the same adjustment. Continue until all isolators are adjusted.
 7. Replace the jam nut on each isolator adjusting bolt, tighten the nut, and remove the shipping tie down block.

Once the shipping tie-downs are removed and the internal isolation is released, it may be necessary to adjust the isolators to achieve the proper operation height of the fan and motor isolation base.

Seismic Requirements

Air handling equipment manufactured by Trane is capable of structurally and operationally withstanding the seismic response criteria as required by the International Building Codes (IBC) 2000,2003, 2006, 2009, 2012, and CBC 2007, 2010. Trane has third-party certification for IBC compliance for seismic applications.

Note: *If seismic isolation has been specified, the following requirements must be adhered to for installation. Failure to follow these instructions would void the warranty.*

Anchor Requirements

1. Single wide <164 inches – grade to roof mounted ($0 \leq Sds \leq 1.85$) non-isolated:
 - a. On 4000 psi concrete:
 - 3/4-in. dia. Hilti Kwik bolt TZ carbon steel concrete anchors at 24 in. o.c.
 - 4 3/4-in. min. anchor embedment
 - 9-in. min. distance to the nearest edge
 - 8-in. min. concrete slab thickness
 - b. On steel dunnage/steel curb:
 - 3/4-in. dia ASTM A325 or SAE grade 5 bolts at 24 in. o.c.
- or**
 - 1-in. long 3/16-in. welds at 24 in. o.c.
2. Stacked single-wide <164 in. – grade to roof mounted ($0 \leq Sds \leq 1.85$) non-isolated:
 - a. On 4000 psi concrete:
 - 3/4-in. dia. Hilti Kwik bolt TZ carbon steel concrete anchors at 24 in. o.c.
 - 4 3/4-in. min. anchor embedment
 - 9-in. min. distance to the nearest edge
 - 8-in. min. concrete slab thickness
 - b. On steel dunnage/steel curb:
 - 3/4-in. dia. ASTM A325 or SAE grade 5 bolts at 24 in. o.c.
- or**
 - 1-in. long 3/16-in. welds at 24 in. o.c.
3. Double-wide 164 in. - 328 in. – grade to roof mounted ($0 \leq Sds \leq 1.85$) non-isolated:
 - a. On 4000 psi concrete:
 - 3/4-in. dia. Hilti Kwik bolt TZ carbon steel concrete anchors at 24 in. o.c.
 - 4 3/4-in. min. anchor embedment
 - 9-in. min. distance to the nearest edge
 - 8-in. min. concrete slab thickness
 - b. On steel dunnage/steel curb:

- 3/4-in. dia. ASTM A325 or SAE grade 5 bolts at 24 in.; o.c.
- or**
- 1-in. long 3/16-in. welds at 24 in. o.c.
4. Stacked double-wide 164 in. - 328 in. – grade to roof mounted ($0 \leq Sds \leq 1.85$) non-isolated:
 - a. On 4000 psi concrete:
 - 3/4-in. dia. Hilti Kwik bolt TZ carbon steel concrete anchors at 24 in. o.c.
 - 4 3/4-in. min. anchor embedment
 - 9-in. min. distance to the nearest edge
 - 8-in. min. concrete slab thickness
 - b. On steel dunnage/steel curb:
 - 3/4-in. dia ASTM A325 or SAE grade 5 bolts at 24 in. o.c.
 - or**
 - 1-in. long 3/16-in. welds at 24 in. o.c.
 5. Ultra wide 328 in. - 600 in. – grade to roof mounted ($0 \leq Sds \leq 1.85$) non-isolated:
 - a. n 4000psi Concrete:
 - 3/4-in. dia. Hilti Kwik bolt TZ carbon steel concrete anchors at 24 in. o.c.
 - 4 3/4-in. min. anchor embedment
 - 12-in. min. distance to the nearest edge
 - 14-in. min. concrete slab thickness
 - b. On steel dunnage/steel curb:
 - 3/4-in. dia ASTM A325 or SAE grade 5 bolts at 24 in. o.c.
 - or**
 - 2 1/2-in. long 3/16-in. welds at 24 in. o.c.

Anchor selection meets or exceeds IBC 2000, 2003, 2006, and 2009 compliance requirements.

Special inspection per IBC Section 1704 is required on all installations. All anchors listed above must be installed to meet compliance.

Hurricane Requirements

Miami/Dade Co. Hurricane Certification

Performance Climate Changer air handlers are approved and have has been designed to comply with the High Velocity Hurricane Zone of the Florida Building Code. Notice of compliance and additional product construction details can be found at the Miami-Dade County, Building Code Compliance Office Web site.

The Florida licensed engineer or architect-of-record for the project shall be responsible for the design, sizing, and structural adequacy of the product framework as well as curbing and attachment to the roof, or as accepted by the corresponding building departments.



Component Installation Requirements

Control Dampers

If the damper actuators are not factory mounted install damper actuators and connecting linkage. Check damper operation and linkage alignment.

Damper blades should be non-binding. Adjust damper frame as necessary to ensure free blade movement.

Filters

⚠ WARNING

Hazardous Voltage w/Capacitors!

Failure to disconnect power and discharge capacitors before servicing could result in death or serious injury.

Disconnect all electric power, including remote disconnects and discharge all motor start/run capacitors before servicing. Follow proper lockout/tagout procedures to ensure the power cannot be inadvertently energized. For variable frequency drives or other energy storing components provided by Trane or others, refer to the appropriate manufacturer's literature for allowable waiting periods for discharge of capacitors. Verify with a CAT III or IV voltmeter rated per NFPA 70E that all capacitors have discharged.

Front-Load Filters

Most filters in custom units are installed in sheet metal frames. Filters are secured with a metal clip. There are several different styles.

To install filters:

1. Disconnect power to the unit.
2. Open or remove the filter clip.
3. Remove the filter from the rack.
4. Install new filters with the directional arrows pointing in the direction of airflow.
5. Secure the filter using the appropriate clip for each filter.

Review [Figure 32](#) through [Figure 35](#) for an explanation of the methods for securing the different types of filters.

The filters are often installed in a pre/post filter configuration. Be sure to note the order of installation.

Note: Filters must have an airtight seal to prevent air bypass.

Figure 32. C-70 fastener holds 2-inch filter

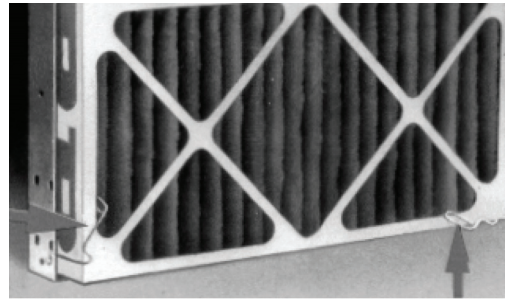

Figure 33. C-86 fastener (shown) or C-77 fastener holds 4-inch pleated filters

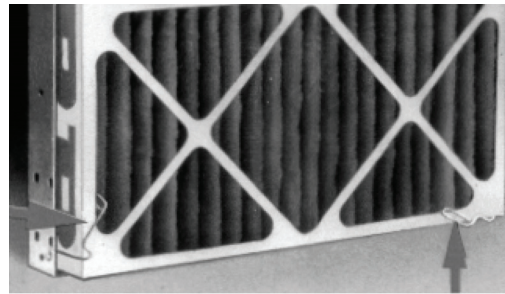

Figure 34. C-70 fastener holds bag filter

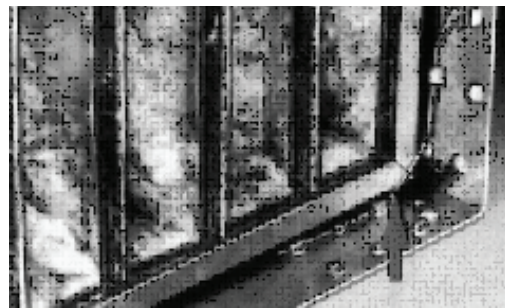
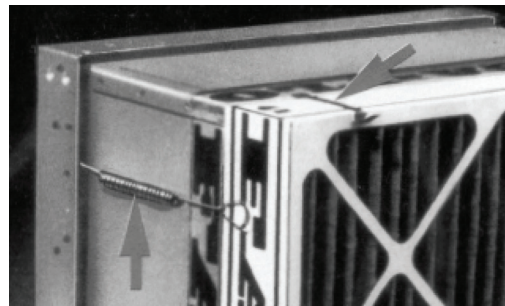

Figure 35. C-80 spring fastener secures cartridge filter



Side-Load Filters

Filters are also available with a side access rack.

2-inch or 4-inch Flat Side-Load Filters

1. Disconnect the power to the unit.
2. Open the filter section access door and remove the filters and block-offs from their installed position.
3. Slide the filter into the rack.
4. Some side load racks will be provided with block-off plates.
5. Close and secure the door, making certain the door closes snug against the block-off.

Figure 36. Filter block-off placement

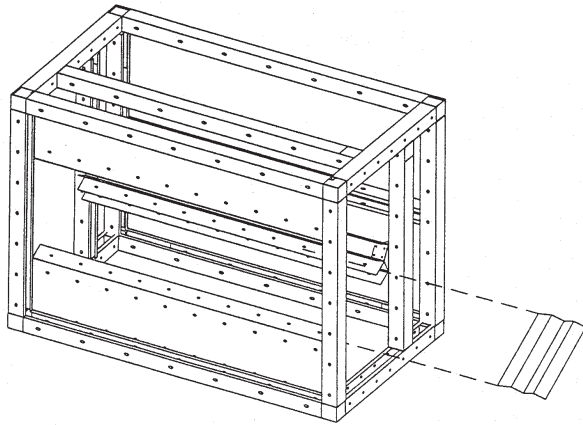

Bag or Cartridge Side-Load Filters

1. Disconnect power to the unit.
2. Keeping the bag filters folded, slide each filter into the filter rack, pushing them tightly against the unit. Pleats should be in the vertical position.
3. If using optional pre-filters, slide them into the appropriate filter rack.
4. If block-offs are provided with the unit, slide the block-offs into the filter track.
5. Close and secure the access door, making certain the door closes snug against the rack.

Note: *The block-off is intended to make a seal when the access door is closed. It may require a few adjustments to ensure a proper seal.*

Magnahelic Air Filter Gage

Check zero adjustment of the gage. Turn both vent valves to the "Vent" position and adjust the gage pointer to zero by means of the external adjustment screw in the face of the gage. After zeroing, turn the vent valves to the "Line" position.

Outdoor Unit Weather Hood(s)

1. Per the unit drawing determine mounting location of the unit weather hoods.
2. Using the factory provided screws mount the weather hoods to the unit.
3. On larger units, weather hoods may be large enough to require angled down supports. In those cases, the angles are shipped attached to the hood but will need to be connected to the air handler by the installing contractor.

Note: *It is required that the hoods be sealed to the unit using field provided caulk or gasket.*

Figure 37. Hood installation

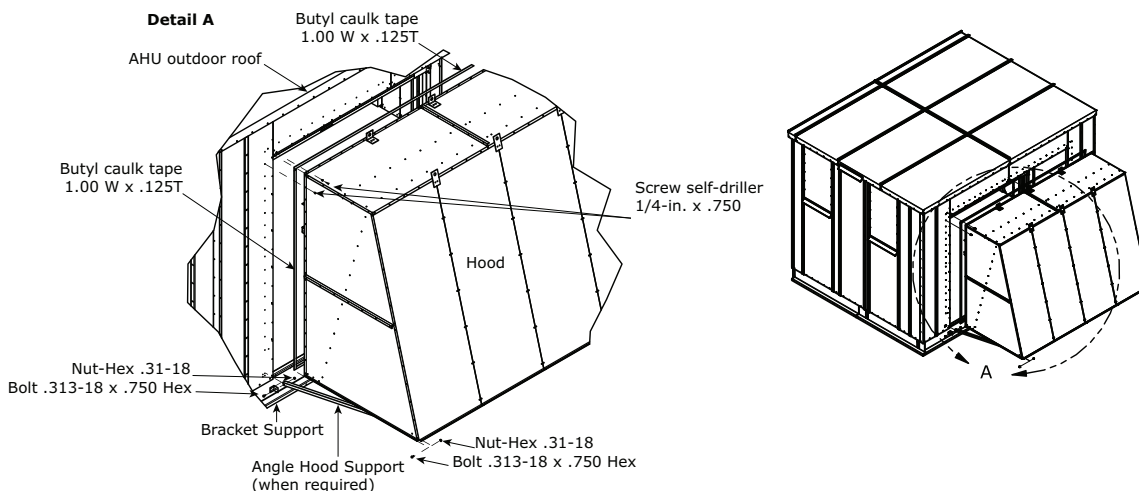

Duct Connections

All duct connections to the air handler should be installed in accordance with the standards of the National Fire Protection Association (NFPA):

- NFPA 90A for installing air conditioning and ventilating systems other than residence type.
- NFPA 90B for residence-type warm air heating and air-conditioning systems.

To ensure the highest fan efficiency, duct turns and transitions must be made carefully, minimizing air friction losses and

turbulence. Proper duct work installation by such organizations as SMACNA (Sheet Metal and Air Conditioning Contractors National Association, Inc.) should be adhered to.

See unit submittal documentation for additional duct mounting information.

Bottom Opening Duct Installation

1. Install gasket to duct flange to ensure air tight seal.
2. Install duct into place underneath framed opening in unit base per [Figure 38](#). Refer to factory curb layout provided with unit submittals for duct size and location.

Figure 38. Field-supplied duct connection to air handler bottom supply/return air opening

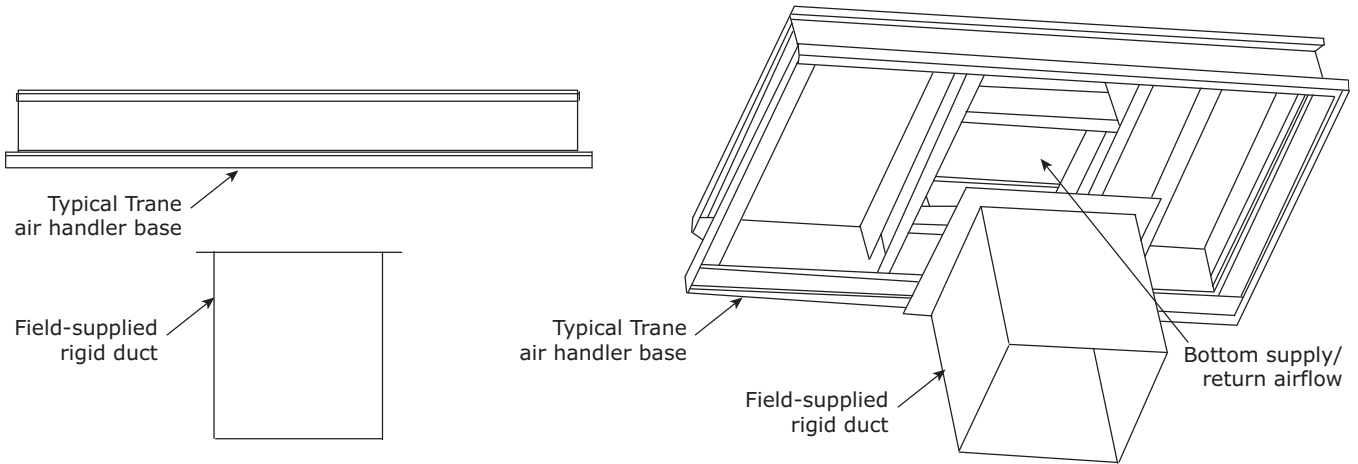

3. Bottom of unit base elevation is lower than edge of duct opening in bottom of unit. During unit installation on roof curb, either raise field provided duct per Option A (see [Figure 39](#)) or add additional gasket material to compensate for the offset per Option B (see [Figure 40](#)).

Note: Bottom of unit base elevation is 1/2 inch lower than edge of duct opening in bottom of unit. During unit installation on roof curb, either raise field-provided duct or add additional gasket material to compensate for the 1/2 inch offset.

Figure 39. Field-supplied duct connection - Option A

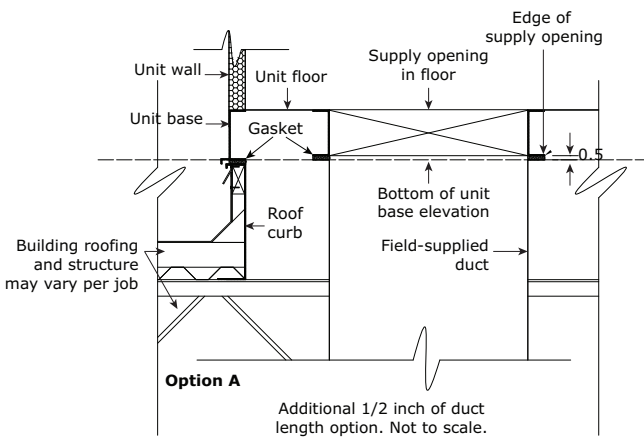
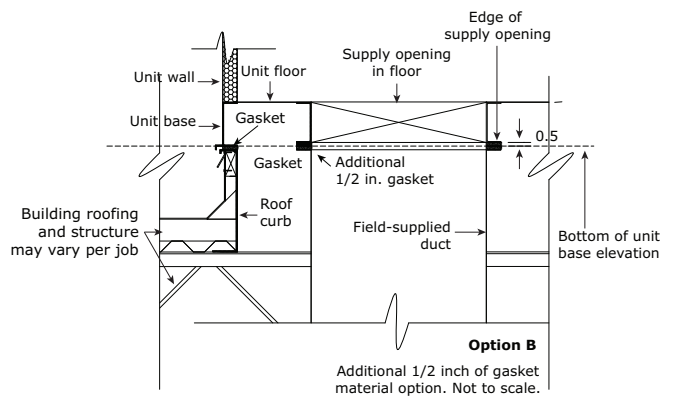

Figure 40. Field-supplied duct connection- Option B



Fan Discharge Connections

To ensure the highest fan efficiency, duct turns and transitions must be made carefully, minimizing air friction losses and turbulence. Proper ductwork installation, as outlined by such organizations as Sheet Metal and Air Conditioning Contractors National Association, Inc. (SMACNA), should be followed closely.

Indoor unit fan sections with rectangular or round openings should have flanged ductwork attached to bottom panel opening. When using lined ducts, the insulation should not obstruct the discharge opening. For plenum fan sections with bell mouth fittings, see [“Bell Mouth Discharge Connections” on page 36](#).

Connections made directly to the discharge opening of a housed fan should have a minimum of three fan diameters of straight duct before any turns or transitions. The ductwork should be the same size as the fan discharge opening. The first turn of the connection should be in the same direction as the fan rotation as shown in [Figure 41](#). The air that the fan discharges into the duct is extremely turbulent and requires some length of duct to stabilize. Abrupt changes in ductwork directly off the fan discharge may adversely affect fan performance and acoustics.

Figure 41. Typical discharge ductwork recommendations

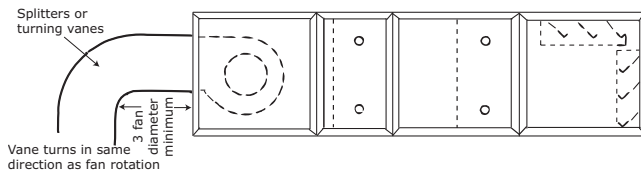

Damper Connections

Standard damper sections include mixing sections, filter mixing sections, face dampers sections, internal face-and-bypass sections, and economizer sections. There are two damper blade configurations available - parallel-blade and opposed-blade. Traq™ dampers are another type of damper available in mixing box sections.

Ductwork attached to the standard damper sections should be sized to fit the opening of the damper. Duct opening dimensions are provided in the submittals. When using lined duct, ensure that the insulation does not obstruct the damper opening (see [Figure 42](#) and [Figure 43](#)).

Note: Damper blades should be checked for proper operation from full-open to full-closed position before unit start up. Damper blade positioning may have changed due to shipping and handling vibrations.

Figure 42. Typical section with duct flat/flange connection - uninsulated or externally insulated

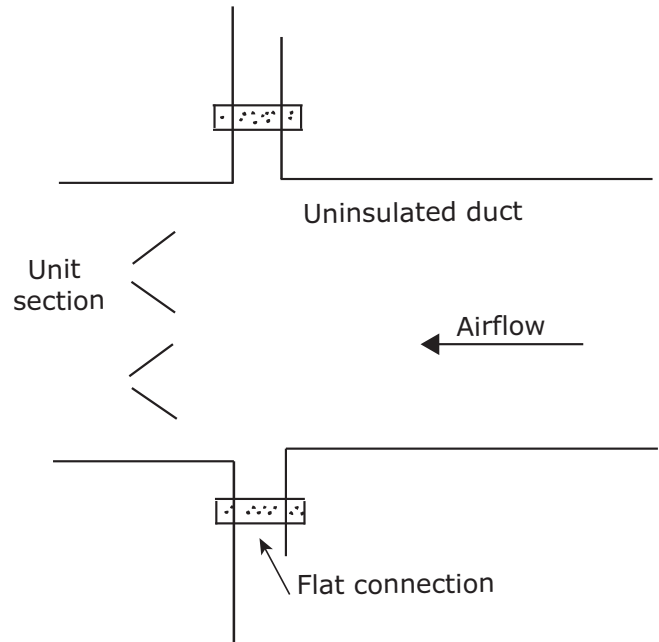
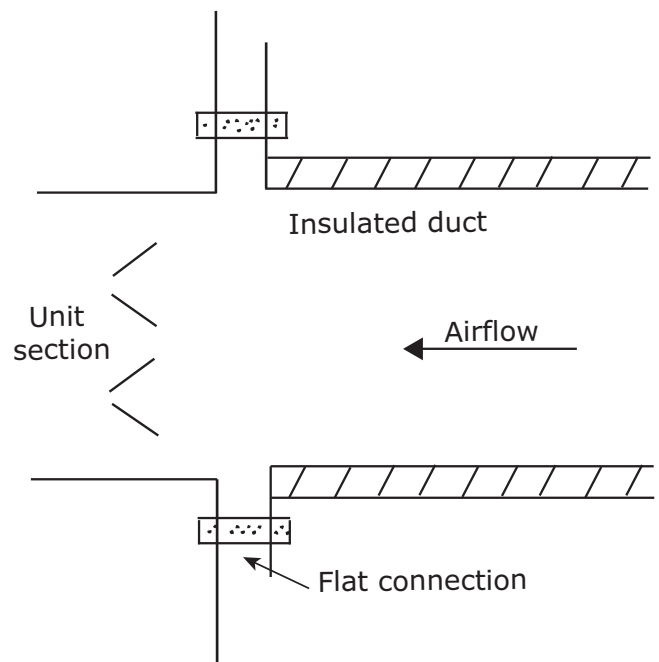

Figure 43. Typical section with duct flat/flange connection - internally insulated



Discharge Plenum Connections

Discharge plenum sections are available with or without openings. Sections with rectangular and round openings have

Component Installation Requirements

a framed opening that can be used to secure the duct to the frames. If the duct is lined, it is important the insulation does not obstruct the opening of the section.

For a discharge plenum with field-cut openings, attach the duct to the side panel.

Bell Mouth Discharge Connections

Round duct connections to be fastened to plenum fan and discharge plenum sections with bell mouth discharge

openings should be sized to attach to the casing or directly to the bell mouth fitting. Attachment to the casing requires the round duct diameter to be sized two inches larger than the nominal bell mouth outlet. An angle ring with a flat flange should be affixed to the round duct to secure the duct to the casing (see Figure 44). Attachment to the bell mouth fitting requires the duct and fitting to be insulated by the installing contractor up to the bell mouth radius to prevent condensation (see Figure 45). The bell mouth fitting extends through the casing by one inch.

Figure 44. Securing round duct to casing over bell mouth **Figure 45. Securing round duct to bell mouth outlet**

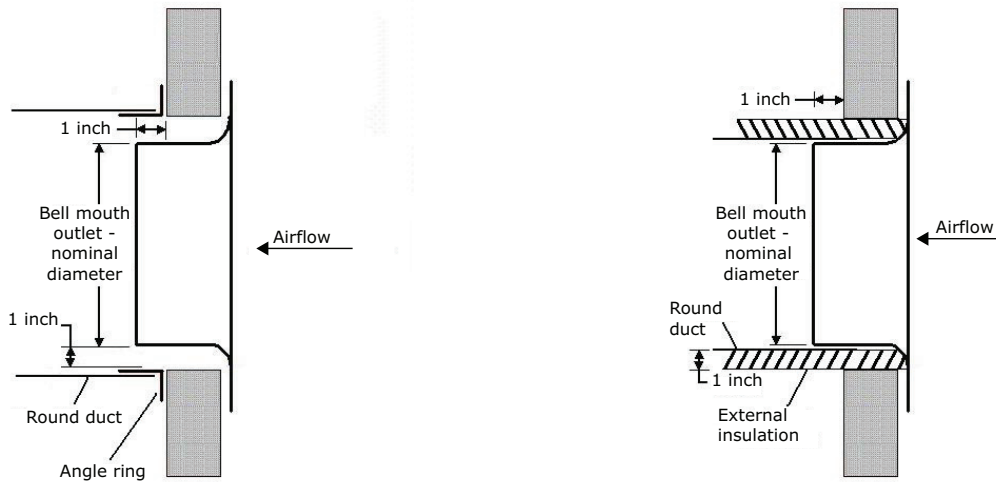

Traq Damper Connections

Size the duct connections to attach to the specified portion on the face of the mixing box that the duct connection completely covers all of the Traq damper.

For a mitered corner, provide one hydraulic duct diameter between the entering face of the Traq dampers and the duct turn. For a radius elbow, or sweep, place the elbow directly against the face of the Traq dampers (see Figure 46).

Figure 46. Traq damper duct connections

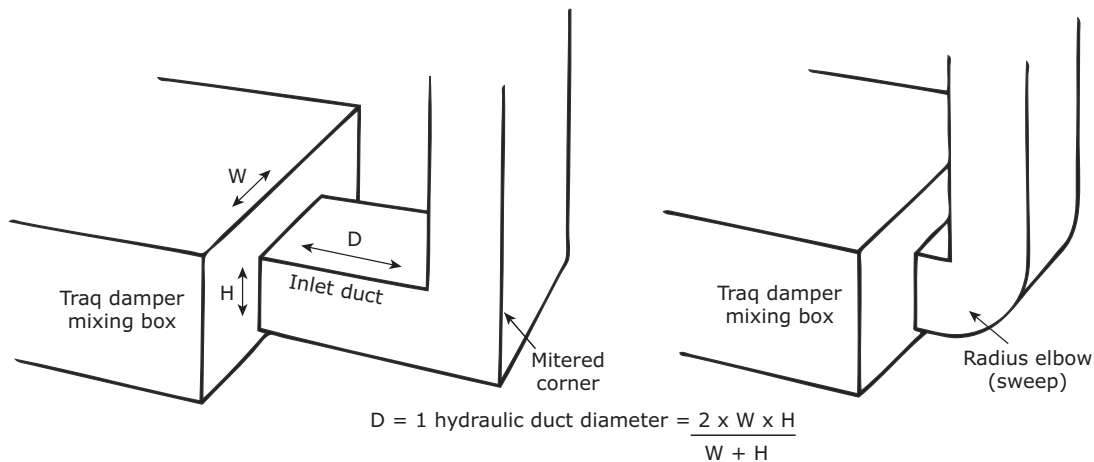



Piping and Connections

NOTICE

Connection Leaks!

Failure to follow instructions below could result in damage to the coil header and cause connection leaks. Use a backup wrench when attaching piping to coils with copper headers. Do not use brass connectors because they distort easily.

NOTICE

Over Tightening!

Failure to follow instructions below could result in damage to the coil header. Do not use teflon-based products for any field connections because their high lubricity could allow connections to be over tightened.

NOTICE

Leakage!

Failure to follow instructions below could result in equipment damage. Properly seal all penetrations in unit casing from inner to outer panel in order to prevent unconditioned air from entering the module, as well as prevent water from infiltrating the insulation.

General Recommendations

Proper installation, piping, and trapping is necessary to ensure satisfactory coil operation and to prevent operational damage:

- Support all piping independently of the coils.
- Provide swing joints or flexible fittings on all connections that are adjacent to heating coils to absorb thermal expansion and contraction strains.
- If the coil was ordered with factory-mounted controls, install the control valves. The valves ship separately.

Note: *The contractor is responsible for supplying the installation hardware.*

- For best results, use a short pipe nipple on the coil headers prior to making any welded flange or welded elbow type connections.
- Extended drain and vent connections are provided as standard on D1 and D2 coils only. If extended drains and vents are required on other water coils, they must be field-installed or ordered as specials from the factory.
- Pipe coils counterflow to airflow.

- When attaching the piping to the coil header, make the connection only tight enough to prevent leaks.

Note: *Do not exceed 200 foot-pounds of torque on supply and return connections. Do not exceed 25 foot-pounds of torque on drain and vent connections.*

- Use pipe sealer on all thread connections.
- After completing the piping connections, seal around pipe from inner panel to outer panel.

Drain Pan Trapping

⚠ WARNING

No Step Surface!

Failure to follow instruction below could result in death or serious injury. Do not walk on the sheet metal drain pan. Walking on the drain pan could cause the supporting metal to collapse and result in the operator/technician falling.

NOTICE

Water Damage!

When more than one section has a drain pan, trap each section individually. Connecting all drains to a common line with only one trap can result in condensate retention and possible water damage to the air handler or adjoining space.

Threaded condensate drain connections are provided on only one side of the coil section. Pitch the connection lines horizontal or downward toward an open drain. Trane recommends installing a plug to facilitate cleaning of the trap.

Figure 47 illustrates the proper trapping, piping, and operation of the trap. Use the formula under the figure to determine the correct minimum depth for the condensate trap. If a section has a drain pan for cleaning purposes only, it does not need a trap; however, a cap or shutoff valve should be installed on the drain connection. Only sections handling condensate, such as a cooling coil section or moisture eliminator section, require a trap.

Figure 47. Drain pan trapping for negative and positive pressure applications

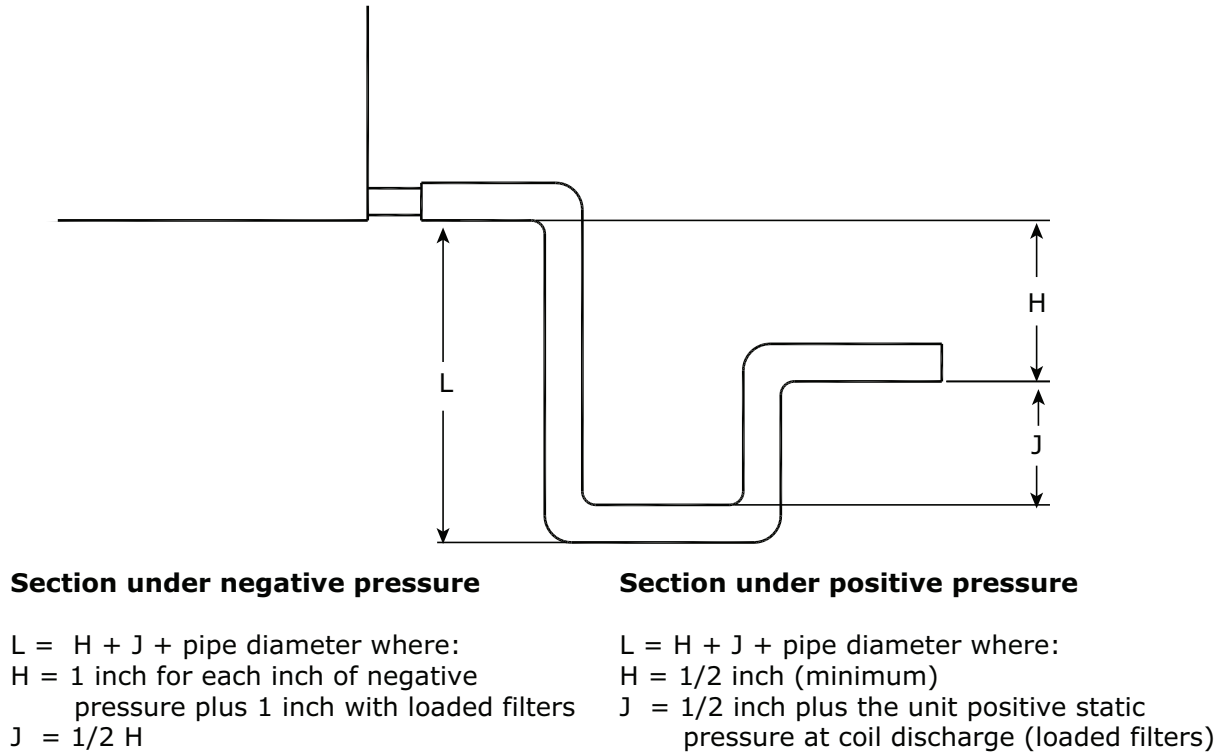

Steam Coil Piping

Air handlers fitted with steam coils have labeled holes for piping penetrations. Figure 48 illustrates a typical steam coil piping configuration. See Table 1 for the codes of system components in these figures.

The coil condensate return line must be piped full size of the condensate trap connection, except for a short nipple screwed directly into the coil header's condensate return tapping. Do not bush or reduce the coil return trapping size.

Table 1. Code of system components for piping figures

Code	System component
FT	Float and thermostatic steam trap
GV	Gate valve
OV	Automatic two-position (ON-OFF) control valve
VB	Vacuum breaker
ST	Strainer
AV	Automatic or manual air vent
MV	Modulating control valve

Figure 48. Typical piping for Type NS steam coils and horizontal tubes for horizontal airflow

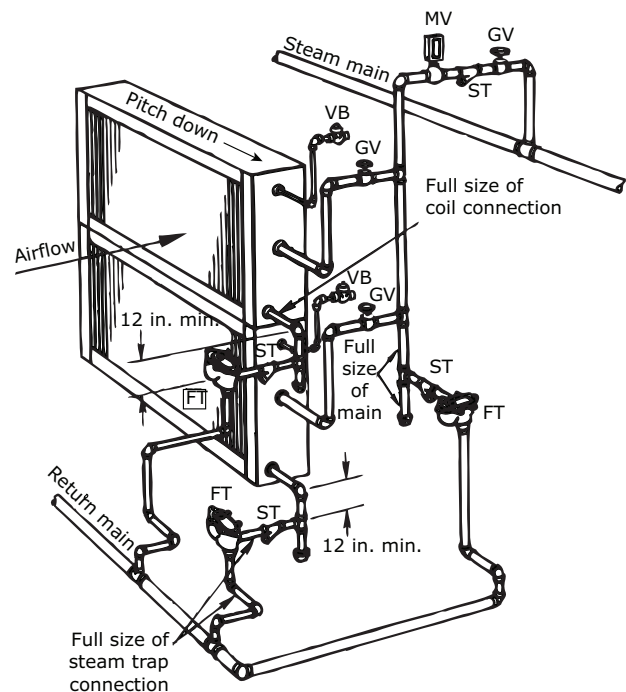

NOTICE**Breaker Cracking Pressure!**

The 1/2-inch NPT, 15 degree swing check valve vacuum breaker is recommended because other vacuum breakers, such as spring-loaded ball-check breakers, have cracking pressures as high as 1.25 inches Hg (17 inches of water). Vacuum breakers with fitting sizes smaller than 1/2 inch NPT are too small to relieve vacuum quick enough to ensure complete condensate drainage. Other types of swing check valve vacuum breakers are acceptable if the fittings size is not smaller than 1/2-inch NPT and the cracking pressure is not larger than 0.25 inches HG (3.5 inches of water). Failure to follow these instructions could result in equipment damage.

To prevent coil damage, complete the following recommendations:

- Install a 1/2-inch NPT, 15 degree swing check valve vacuum breaker with cracking pressure of 0.25 inches Hg (3.4 inches water) or lower at the top of the coil. This vacuum breaker should be installed as close to the coil as possible.
- For coil type NS, install the vacuum breaker in the unused condensate return tapping at the top of the coil.
- Vent the vacuum breaker line to atmosphere or connect it into the return main at the discharge side of the steam trap

Note: Vacuum breaker relief is mandatory when the coil is controlled by a modulating steam supply or automatic two position (ON-OFF) steam supply valve. Vacuum breaker relief is also recommended when face-and-bypass control is used.

NOTICE**Coil Damage!**

Failure to follow instructions below could result in equipment damage.

Condensate must flow freely from the coil at all times to prevent coil damage from water hammer, unequal thermal stresses, freeze-up and/or corrosion.

Proper steam trap installation is necessary for satisfactory coil performance and service life. For steam trap installation:

1. Install the steam trap discharge 12 inches below the condensate return connection. Twelve inches provides sufficient hydrostatic head pressure to overcome trap losses and ensures complete condensate removal.
 - a. Use float and thermostatic traps with atmospheric pressure gravity condensate return, with automatic controls, or where the possibility of low-pressure supply steam exists. (Float and thermostatic traps are recommended because of gravity drain and continuous discharge operation.)
 - b. Use bucket traps only when the supply steam is not modulated and is 25 psig or higher.

Note: Trane steam coils require a minimum of 2 psi of pressure to assure even heat distribution.

2. Trap each coil separately to prevent holding up condensate in one or more of the coils.
3. Install strainers as close as possible to the inlet side of the trap.
4. If installing coils in series airflow, control each coil bank independently with an automatic steam-control valve. Size the traps for each coil using the capacity of the first coil in direction of airflow.
5. Use a modulating valve that has linear flow characteristics to obtain gradual modulation of the coil steam supply.

Note: Do not modulate systems with overhead or pressurized returns unless the condensate is drained by gravity into a receiver, vented to atmosphere, and returned to the condensate pump.

6. Pitch all supply and return steam piping down 1 inch for every 10 feet in the direction of the steam or condensate flow.

Note: Do not drain the steam mains or take-offs through the coils. Drain the mains ahead of the coils through a steam trap to the return line.

7. Ensure overhead returns have 1 psig of pressure at the steam trap discharge for every 2 feet of elevation for continuous condensate removal.

Water Coil Piping

Figure 49 and Figure 50 illustrate typical water coil piping configurations.

Water coils are self-venting only if the water velocity exceeds 1.5 feet per second (fps) in the coil tubes. See the unit submittals for coil water velocity. If the water velocity is below these minimums, vent the coil by one of the following methods:

1. Install an air vent in the top pipe plug tapping of the return header.
2. When the return line rises above the top of the coil, vent from the top of the return header horizontally to the return piping.

Figure 49. Typical piping for one-row water coil

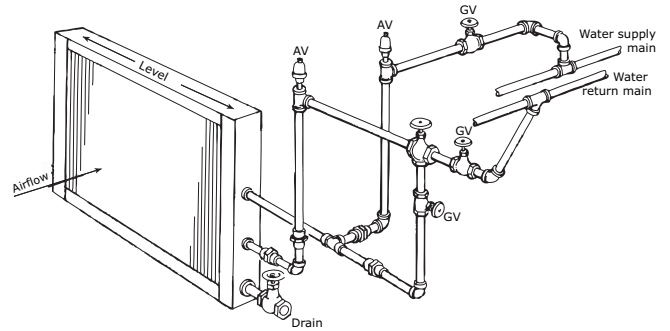
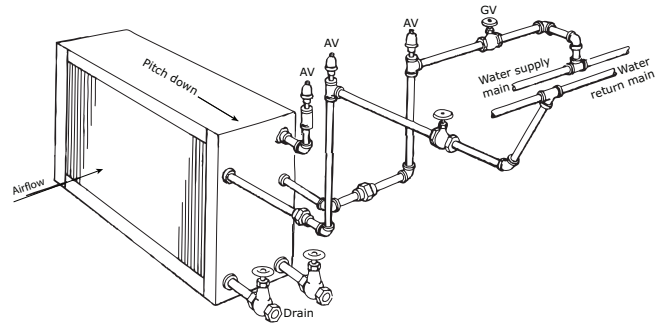

Figure 50. Typical piping for 2 - 8-row water coils



Refrigerant Coil Piping

Note: Refer to for information on handling refrigerants.

Figure 51 illustrates an example of a split-system component arrangement. Use it to determine the proper, relative sequence of the components in the refrigerant lines that connect the condensing unit to an evaporator coil. Refer to “Field-Installed Evaporator Piping Examples,” p. 45 for more detailed schematics of evaporator piping.

Figure 51. Example of placement for split-system components

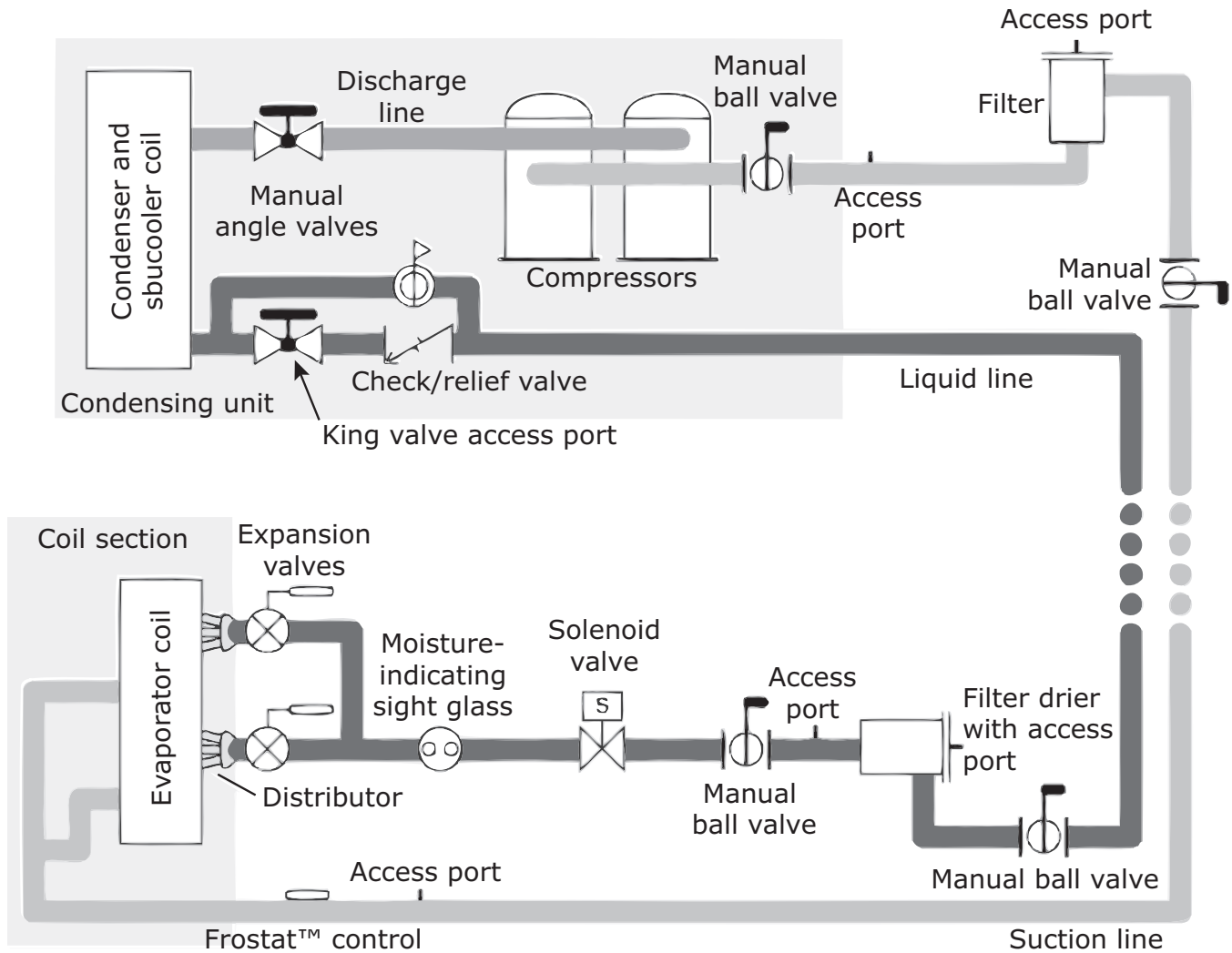

Kit with sensor - X13790452010 SEN-01212
 Kit with switch - X13100429010 THT 02442

Liquid Lines

Line Sizing

Properly sizing the liquid line is critical to a successful split-system application. The selected tube diameter must provide at least 5°F [2.7°C] of subcooling at the expansion valve throughout the operating envelope. Increasing the size of the liquid line will not increase the available subcooling.

Routing

Install the liquid line with a slight slope in the direction of flow so that it can be routed with the suction line. Minimize tube bends and reducers because these items tend to increase pressure drop and to reduce subcooling at the expansion valve. Liquid line receivers, other than those that are factory-installed, are not recommended.

Insulation

The liquid line is generally warmer than the surrounding air, so it does not require insulation. In fact, heat loss from the liquid line improves system capacity because it provides additional subcooling. However, if the liquid line is routed through a high-temperature area, such as an attic or a mechanical room, insulation would be required.

Components

Liquid-line refrigerant components necessary for a successful job include a filter drier, access port, solenoid valve, moisture-indicating sight glass, expansion valve(s), and ball shutoff valves. [Figure 51](#) illustrates the proper sequence for positioning them in the liquid line. Position the components as close to the evaporator as possible.

- **Filter drier.** There is no substitute for cleanliness during system installation. The filter drier prevents residual contaminants, introduced during installation, from entering the expansion valve and solenoid valve.
- **Access port.** The access port allows the unit to be charged with liquid refrigerant and is used to determine subcooling. This port is usually a Schraeder® valve with a core.
- **Solenoid valve.** In split systems, solenoid valves isolate the refrigerant from the evaporator during off cycles; under certain conditions, they may also trim the amount of active evaporator as compressors unload. Generally, the “trim” solenoid valve is unnecessary for VAV comfort-cooling applications, and is only required for constant-volume applications when dehumidification is a concern. In split systems with microchannel heat exchanger condensers (MCHE), solenoid valves isolate the refrigerant from the evaporator during the off cycles. Trim solenoids cannot be used with MCHE.

Note: *Trane condensing units with MCHE no longer employ pump-down, but isolation solenoids are required. The suggested solenoid uses a 120-volt service and requires code-compliant wiring to the condensing unit.*

- **Moisture-indicating sight glass.** Be sure to install one moisture-indicating sight glass in the main liquid line. The only value of the sight glass is its moisture indication ability. Use actual measurements of temperature and pressure—not the sight glass—to determine subcooling and whether the system is properly charged. The moisture indicator/sight glass must be sized to match the size of the liquid line at the thermal expansion valve.

NOTICE

Valve Damage!

Failure to protect the valve from high temperatures could result in damage to internal components. Disassemble the thermal expansion valve before completing the brazing connections. If necessary, wrap the valve in a cool, wet cloth while brazing.

- **Thermal expansion valve.** The expansion valve is the throttling device that meters the refrigerant into the evaporator coil. Metering too much refrigerant floods the compressor; metering too little elevates the compressor temperature. Choosing the correct size and type of expansion valve is critical to assure it will correctly meter refrigerant into the evaporator coil throughout the entire operating envelope of the system. *Correct refrigerant distribution into the coil requires an expansion valve for each distributor.*
The thermal expansion valve must be selected for proper size and capacity. The size of the expansion valve should cover the full range of loadings. Check that the valve will successfully operate at the lightest load condition. For improved modulation, choose expansion valves with balanced port construction and external equalization. Cut the process tube and cap assembly from the liquid connection as shown in [Figure 52](#) and install the expansion valve directly to the liquid connections.

Figure 52. Type F refrigerant coil with packed elbow

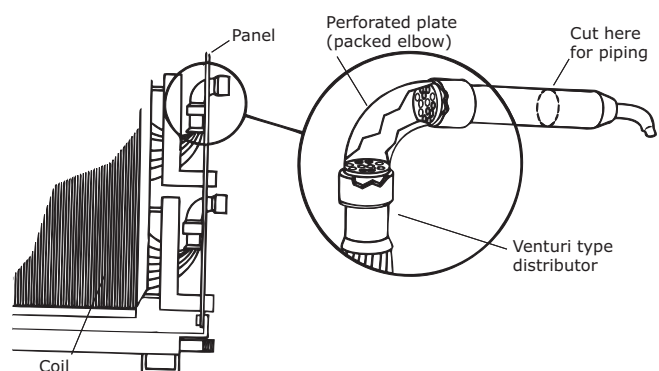

- **Ball shutoff valves.** Adding manual, ball-type shutoff valves upstream and downstream of the filter simplifies replacement of the filter core.

Suction Lines

Line sizing

Proper line sizing is required to guarantee the oil returns to the compressor throughout the system's operating envelope. At the same time, the line must be sized so that the pressure drop does not excessively affect capacity or efficiency. To accomplish both objectives, it may be necessary to use two different line diameters: one for the horizontal run and for the vertical drops, and another for the vertical lifts (risers).

Routing

To prevent residual or condensed refrigerant from "free-flowing" toward the compressor during the off cycle, install the suction line so it slopes by ¼ inch to 1 inch per 10 feet of run toward the evaporator.

When the application includes a suction riser, oil must be forced to travel the height of the riser. Riser traps are unnecessary in the suction line. They will add pressure drop. Double risers must not be used. They not only add pressure drop, but can hold great amounts of oil - oil better used in the compressor.

Note: *If a suction riser is properly sized, oil will return to the compressor regardless of whether a trap is present. If a suction riser is oversized, adding a trap will not restore proper oil entrainment.*

Avoid Underground Refrigerant Lines

Refrigerant condensation during the off cycle, installation debris inside the line (including condensed ambient moisture), service access, and abrasion/corrosion can quickly impair reliability.

Insulation

Any heat that transfers from the surrounding air to the cooler suction lines increases the load on the condenser (reducing the system's air-conditioning capacity) and promotes condensate formation. After operating the system and testing all fittings and joints to verify that the system is leak-free, insulate suction lines to prevent heat gain and unwanted condensation.

Components

Installing the suction line requires field installation of these components: a filter, access port, and a Froststat™ control when the refrigerant coil is used with Trane condensing units. Position them as close to the compressor as possible.

Note: *Placement of the Froststat control is illustrated in Figure 51 on page 41.*

- **Filter.** The suction filter prevents contaminants, introduced during installation, from entering the compressor. For this reason, the suction filter should be the replaceable-core type, and a clean core should be installed after the system is cleaned up.

- **Access port.** The access port is used to determine suction pressure. This port is usually a Schraeder valve with a core.
- **Froststat™ coil frost protection.** The Froststat control is the preferred method for protecting evaporator coils from freezing when the refrigerant coil is used with Trane condensing units. It senses the suction-line temperature and temporarily disables mechanical cooling if it detects frost conditions. The control is mechanically attached to the outside of the refrigerant line, near the evaporator, and wired to the unit control panel.
- **Ball shutoff valve.** Adding manual, ball-type shutoff valves upstream and downstream of the filter simplifies replacement of the filter core.

Expansion Valves

Expansion valves meter refrigerant into the evaporator under controlled conditions. If there is too much refrigerant, the refrigerant will not completely vaporize and the remaining liquid will slug the compressor. If there is too little refrigerant, there may not be enough cooling for the compressor.

Expansion valve requirements vary based on condensing unit design. Consult the product literature for the condensing unit to be used for proper valve selection.

Hot Gas Bypass

Many years ago, hot gas bypass (HGBP) was successfully added to HVAC systems to correct a number of operational problems. Hoping to avoid such problems altogether, it eventually became common practice for designers to specify hot gas bypass in new systems. Unfortunately, the practice often degraded rather than improved reliability.

Hot gas bypass increases the minimum refrigerant charge; it also inflates the first cost of the system. Besides adding more paths for potential refrigerant leaks, hot gas bypass increases the likelihood of refrigerant distribution problems. Finally, hot gas bypass uses excessive amounts of energy by preventing the compressors from cycling with fluctuating loads.

Trane now has many years of experience in the successful use of equipment *without hot gas bypass* in commercial comfort-cooling applications. To prevent evaporator freeze-up, Trane equipment typically includes Froststat™ coil frost protection.

Like hot gas bypass, the Froststat system protects the coil from freezing, but it does so by turning off compressors when a sensor detects the formation of frost on the evaporator coil. The compressor is released to operate when the coil temperature rises a few degrees above the frost threshold. The Froststat control strategy reduces the overall energy consumption of the system while maintaining system control.

Systems should be designed to avoid HGBP whenever possible. For more information about HGBP, refer to the *Engineers Newsletter*, "Hot Gas Bypass – Blessing or a Curse?" (ADM-APN007*-EN).



Remodel, Retrofit, or Replacement

Inevitably, older condensing units and evaporator systems will need to be replaced or retrofitted. Due to the phase-out of many of these older refrigerants, the major components for those older units or systems may no longer be available. The only option will be to convert the system to R-410A, POE oil, and R-410A components.

When upgrading an existing refrigerant split system due to remodel, retrofit, or replacement, the entire system must be reviewed for compatibility with R-410A and POE oil. Each and every part of the split HVAC system **MUST** be compatible with the properties of R-410A refrigerant and POE oil. In addition, ensure the existing electrical service is adequate for the product being installed.

⚠ WARNING

R-410A Refrigerant under Higher Pressure than R-22!

Failure to use proper equipment or components as described below, could result in equipment failing and possibly exploding, which could result in death, serious injury, or equipment damage.

The units described in this manual use R-410A refrigerant which operates at higher pressures than R-22. Use ONLY R-410A rated service equipment or components with these units. For specific handling concerns with R-410A, please contact your local Trane representative.

Every part of an existing split system needs to be analyzed to determine if it can be reused in an R-410A and POE oil system:

- R-22 condensing units will not work with R-410A; they must be replaced.
- Most older evaporator coils were not pressure- and cycle-rated for R-410A pressures. If they weren't, they will need to be replaced. If they were properly pressure-rated for R-410A, existing coils must be modeled to determine if they will meet capacity requirements, are properly circuited, have correctly sized distributor tubes, and employ acceptable distributors and orifices.
- The required R-410A line sizes may be different than the existing line sizes. The lines need to be re-sized and compared to existing lines for reusability.
- Suction lines 2-5/8 OD and smaller of type L copper are suitable for use with R-410A. Suction lines 3-1/8 OD must use type K or thicker wall.
- Discharge lines, liquid lines, heat pump vapor lines, and hot gas bypass lines 1-3/8 OD and smaller of type L copper are suitable for use with R-410A. These same lines sized at 1-5/8 OD or 2-1/8 OD must use type K or thicker wall.

- Expansion valves need to be reselected. Expansion valves are refrigerant specific.
- Any gasket or o-ring should be replaced. Shrinkage of the original seal may occur after an HFC conversion, potentially causing a refrigerant leak. Components commonly affected are Schraeder cores, solenoid valves, ball valves, and flange seals. But *all* external seals in contact with refrigerant should be viewed as potential leak sources after a retrofit.
- All other valves, filters, valve packing, pressure controls, and refrigeration accessories must be researched through their manufacturer for compatibility with the pressures of an R-410A system, and for their compatibility with the newer POE oil.
- For the best performance and operation, the original mineral oil should be removed from the components of the system that are not being replaced. Any component of the system that is suspected of trapping oil (piping, traps, and coil), should be dismantled, drained, and reassembled. After all components have been drained, the amount of residual mineral oil will have a negligible effect on performance and reliability.

NOTICE

Compressor Damage!

POE oil is hygroscopic – it absorbs water directly from the air. This water is nearly impossible to remove from the compressor oil and can result in compressor failures.

To prevent POE oil from absorbing water, the system should not remain open for longer than necessary. When open, dry nitrogen should flow through the piping. Only new oil containers should be used for service and maintenance. Always use the smallest container size required for the job requirements. Always leave the oil container tightly sealed until time of use. Do not reuse oil that has been opened.

All Codes take precedence over anything written here.

Field-Installed Evaporator Piping Examples

Figure 53. Single-circuit condensing unit: evaporator coil with one distributor

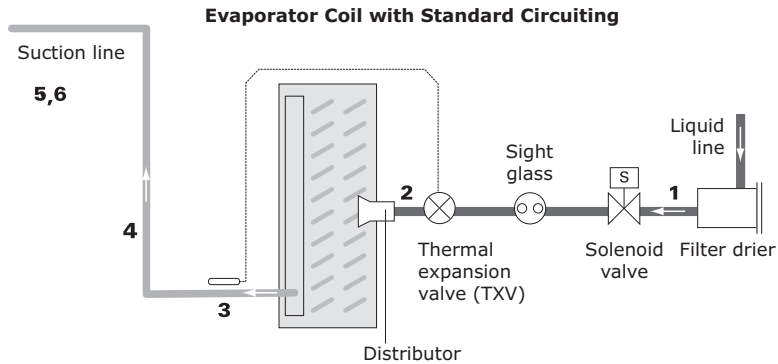

1. Pitch the liquid line slightly—1 inch/10 feet—so that the refrigerant drains toward the evaporator.
2. Provide one expansion valve per distributor.
3. Slightly pitch the outlet line from the suction header toward the suction riser—that is, 1 inch/10 feet in the direction of flow. Use the tube diameter that matches the suction-header connection.
4. Use the tube diameter recommended in the condensing unit application manual for a vertical rise. Ensure that the top of the riser is higher than the evaporator coil.
5. Pitch the suction line slightly—1 inch/10 feet—so the refrigerant drains toward the evaporator.
6. Insulate the suction line.

Figure 54. Single-circuit condensing unit: evaporator coil with two distributors

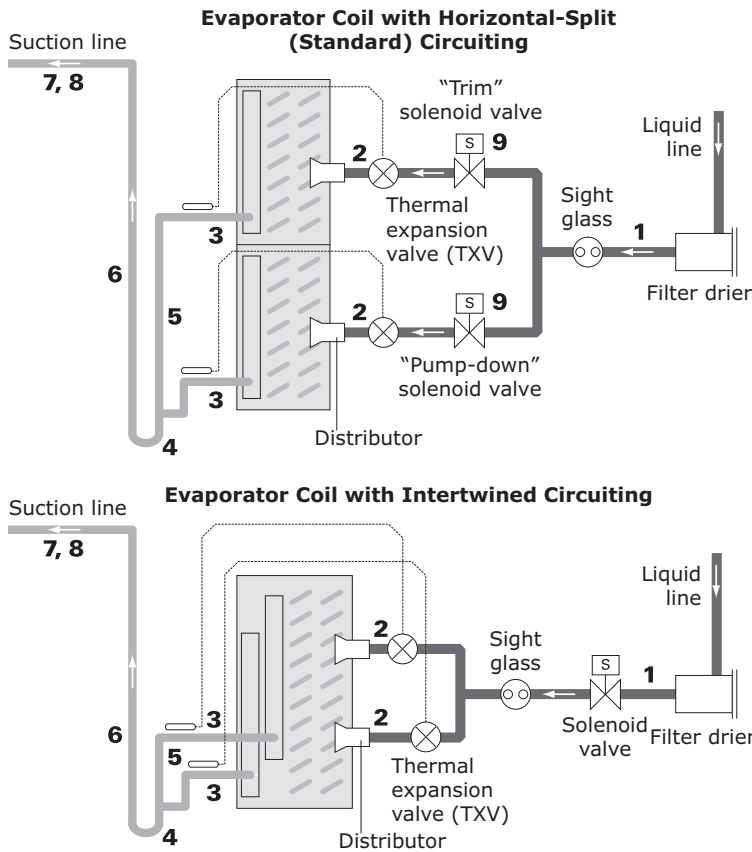

1. Pitch the liquid line slightly—1 inch/10 feet—so the refrigerant drains toward the evaporator.
2. Provide one expansion valve per distributor.
3. Slightly pitch the outlet line from the suction header toward the suction riser— 1 inch/10 feet in the direction of flow. Use the tube diameter that matches the suction-header connection. Use a double-elbow configuration to isolate the TXV bulb from other suction headers.
4. This looks like a trap, but is actually due to the requirement that the refrigerant gas leaving the coil flows downward, past the lowest suction-header outlet, before turning upward.
5. Use the “horizontal” tube diameter as specified in the condensing unit application manual.
6. Use the tube diameter recommended for a vertical rise as specified in the condensing unit application manual. Assure the top of the riser is higher than the evaporator coil.
7. Pitch the suction line slightly—1 inch/10 feet—so that the refrigerant drains toward the evaporator.
8. Insulate the suction line.
9. Only use a “trim” solenoid valve for constant-volume, humidity-sensitive applications. For all other applications, install a single solenoid valve (the “pumpdown” solenoid valve) between the liquid-line filter drier and the sight glass.

Note: Due to reduced coil volume in condensing units with microchannel heat exchanger condenser, do not use trim solenoid valves for these units.

Figure 55. Single-circuit condensing unit: evaporator coil with four distributors

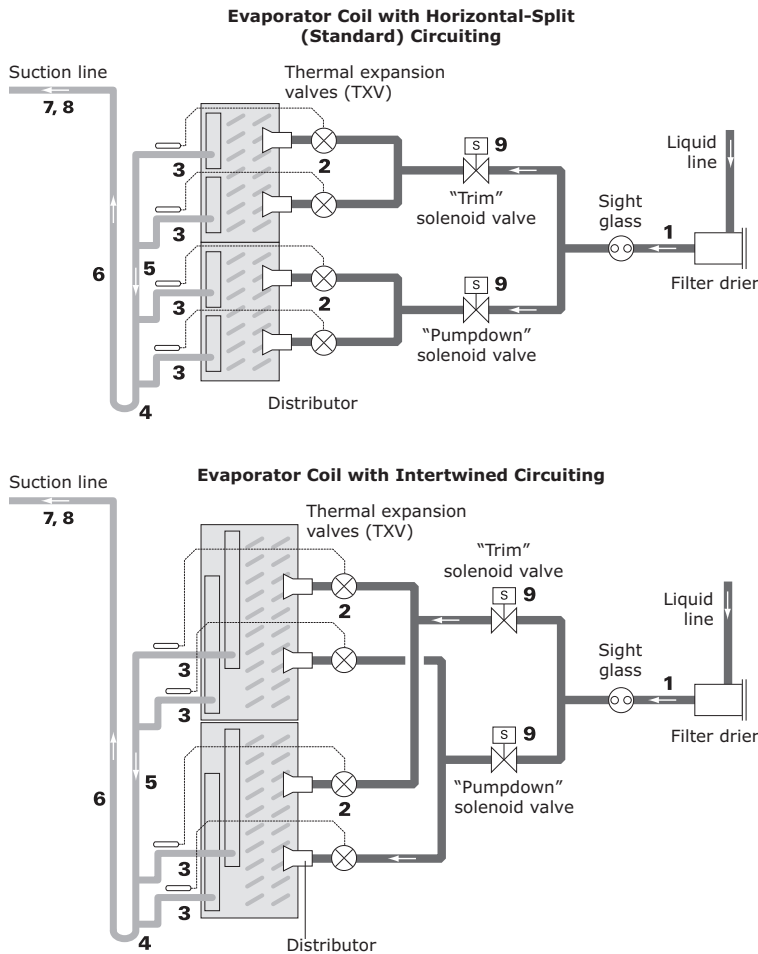

1. Pitch the liquid line slightly—1 inch/10 feet—so that the refrigerant drains toward the evaporator.
2. Provide one expansion valve per distributor.
3. Slightly pitch the outlet line from the suction header toward the suction riser— 1 inch/10 feet in the direction of flow. Use the tube diameter that matches the suction-header connection.
4. This looks like a trap, but is actually due to the requirement that the refrigerant gas leaving the coil flows downward, past the lowest suction-header outlet, before turning upward. Use the double-elbow configuration to isolate the TXV bulb from other suction headers.
5. Use the “horizontal” tube diameter as specified in the condensing unit application manual.
6. Use the tube diameter recommended for a vertical rise as specified in the condensing unit application manual. Ensure that the top of the riser is higher than the evaporator coil.
7. Pitch the suction line slightly—1 inch/10 feet —so that the refrigerant drains toward the evaporator.
8. Insulate the suction line.
9. Only use a “trim” solenoid valve for constant-volume, humidity-sensitive applications. For all other applications, install a single solenoid valve (the “pumpdown” solenoid valve) between the liquid-line filter drier and the sight glass.

Note: Due to reduced coil volume in condensing units with microchannel heat exchanger condenser, do not use trim solenoid valves for these units.

Figure 56. Dual-circuit condensing unit: evaporator coil with two distributors

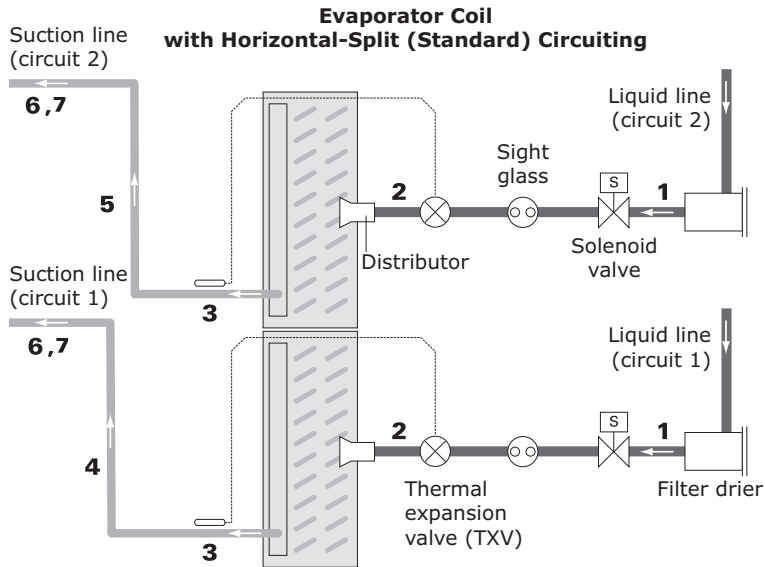

1. Pitch the liquid lines slightly—1 inch/10 feet—so that the refrigerant drains toward the evaporator.
2. Provide one expansion valve per distributor.
3. Slightly pitch the outlet line from the suction header toward the suction riser—1 inch/10 feet in the direction of flow. Use the tube diameter that matches the suction-header connection.
4. The top of the Circuit 1 suction riser must be higher than the bottom evaporator coil. Use the tube diameter recommended for a vertical rise as specified in the condensing unit application manual.
5. The top of the Circuit 2 suction riser must be higher than the top evaporator coil. Use the tube diameter recommended for a vertical rise as specified in the condensing unit application manual.
6. Pitch the suction lines slightly—1 inch/10 feet—so that the refrigerant drains toward the evaporator.
7. Insulate the suction lines.

Figure 57. Dual-circuit condensing unit: evaporator coil with four distributors

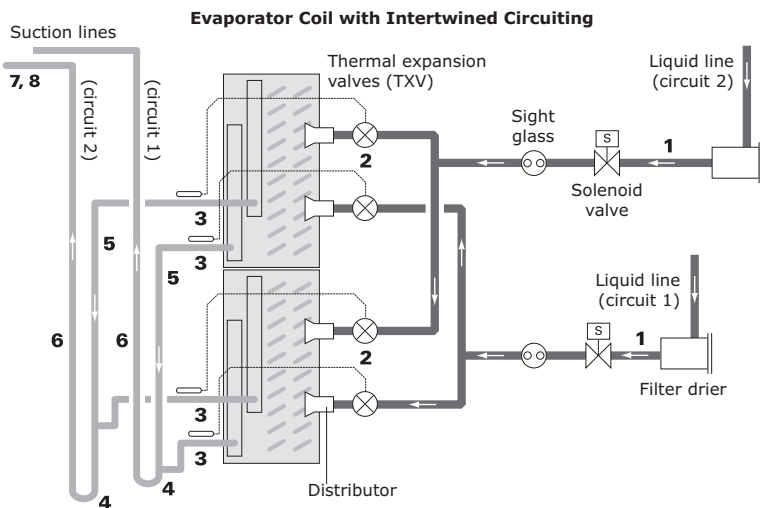
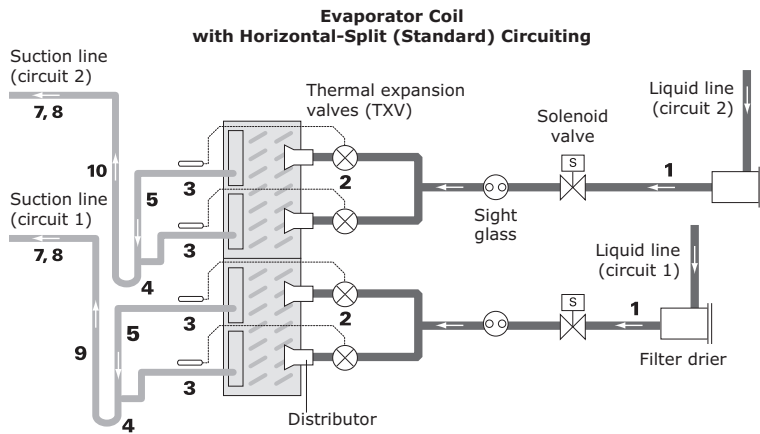

1. Pitch the liquid line slightly—1 inch/10 feet—so that the refrigerant drains toward the evaporator.
2. Provide one expansion valve per distributor.
3. Slightly pitch the outlet line from the suction header toward the suction riser— 1 inch/10 feet in the direction of flow. Use the tube diameter that matches the suction-header connection.
4. This looks like a drain trap, but is actually due to the requirement that the refrigerant gas leaving the coil flows downward, past the lowest suction-header outlet, before turning upward. Use the double-elbow configuration to isolate the TXV bulb from other suction headers.
5. Use the “horizontal” tube diameter as specified in the condensing unit application manual.
6. Use the tube diameter recommended for a vertical rise as specified in the condensing unit application manual. Ensure that the top of the riser is higher than the evaporator coil.
7. Pitch the suction line slightly—1 inch/10 feet —so that the refrigerant drains toward the evaporator.
8. Insulate the suction line.
9. The top of the Circuit 1 suction riser must be higher than the bottom evaporator coil. Use the tube diameter recommended for a vertical rise as specified in the condensing unit application manual.
10. The top of the Circuit 2 suction riser must be higher than the top evaporator coil. Use the tube diameter recommended for a vertical rise as specified in the condensing unit application manual.

Figure 58. Dual-circuit condensing unit: evaporator coil with eight distributors

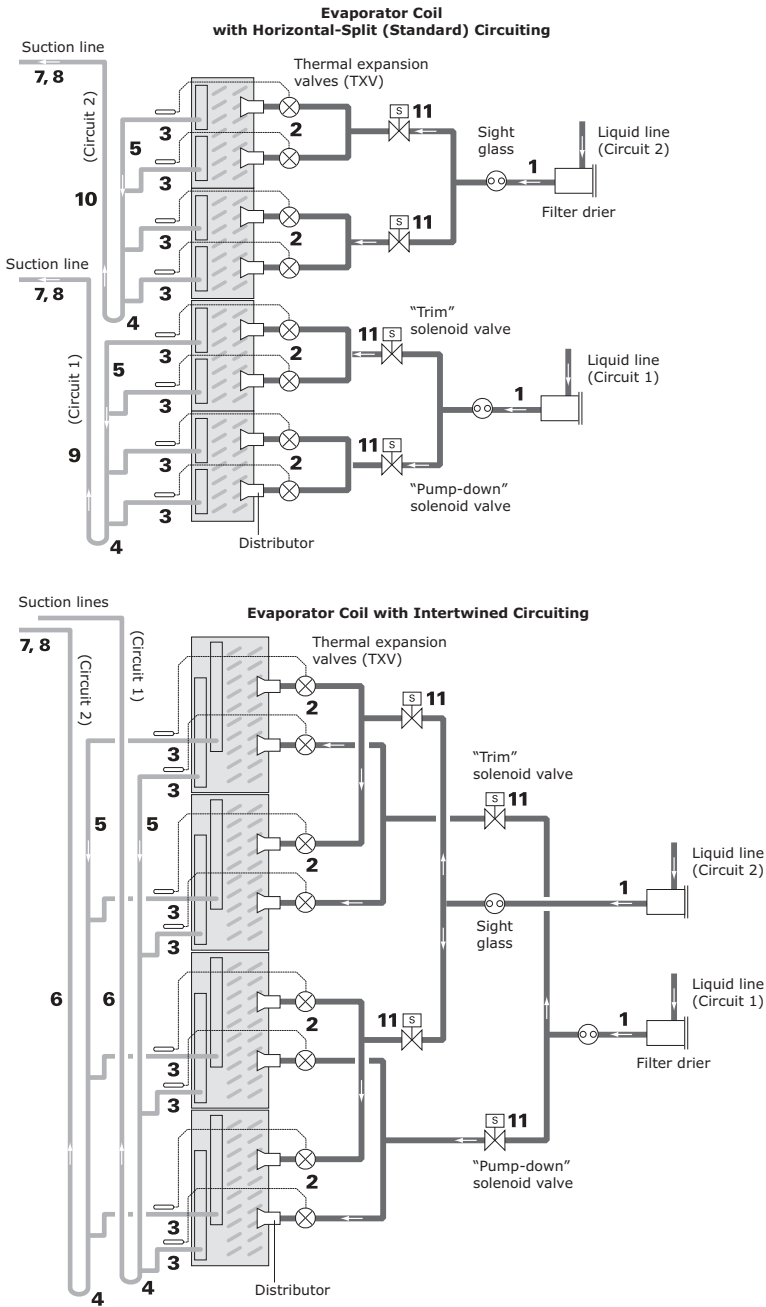

1. Pitch the liquid line slightly—1 inch/10 feet—so that the refrigerant drains toward the evaporator.
2. Provide one expansion valve per distributor.
3. Slightly pitch the outlet line from the suction header toward the suction riser— 1 inch/10 feet in the direction of flow. Use the tube diameter that matches the suction-header connection.
4. This looks like a trap, but is actually due to the requirement that the refrigerant gas leaving the coil flows downward, past the lowest suction-header outlet, before turning upward. Use the double-elbow configuration to isolate the TXV bulb from other suction headers.
5. Use the “horizontal” tube diameter as specified in the condensing unit application manual.
6. Use the tube diameter recommended for a vertical rise as specified in the condensing unit application manual. Ensure that the top of the riser is higher than the evaporator coil.
7. Pitch the suction line slightly—1 inch/10 feet—so that the refrigerant drains toward the evaporator.
8. Insulate the suction line.
9. The top of the Circuit 1 suction riser must be higher than the bottom evaporator coil. Use the tube diameter recommended for a vertical rise as specified in the condensing unit application manual.
10. The top of the Circuit 2 suction riser must be higher than the top evaporator coil. Use the tube diameter recommended for a vertical rise as specified in the condensing unit application manual.
11. Only use a “trim” solenoid valve for constant-volume, humidity-sensitive applications. For all other applications, install a single solenoid valve (the “pumpdown” solenoid valve) between the liquid-line filter drier and the sight glass.

Note: Due to reduced coil volume in condensing units with microchannel heat exchanger condenser, do not use trim solenoid valves for these units.

Humidifier Piping and Connections

These instructions cover the piping installation for Trane's building steam humidifier panel and atmospheric steam humidifier panel. The humidifier panel shall arrive installed in the unit air cabinet.

Units with a humidifier panel to be used with building (boiler) steam will also receive the following piping accessories shipped direct from the humidifier vendor to the jobsite address.

- Inverted bucket steam trap (to be used to drip steam supply to control valve)
- Control valve
- In-line Y strainer (to be used prior to the control valve)
- Float and thermostatic steam trap (for condensate drainage of header, two required)

Units with a humidifier panel to be used with atmospheric distribution of steam generated by electric or steam-to-steam humidifiers (steam generating) are not supplied with piping accessories unless the factory provides the steam generator installed inside the unit. Piping will be determined by requirement of field-provided steam generator.

All accessories listed above will be on the packing slip. Report any shortages immediately. If accessories have been damaged in transit, notify Trane and file claim with the transportation company. If your order covers more than one package, segregate complete assembly. Equipment tagging will be the same as shown on the packing list.

All piping accessories should be installed in accordance with all applicable building, plumbing, and electrical codes.

Condensate discharged from the humidifier separator/header is essentially atmospheric pressure. Thus condensate must be discharged to a drain or pumped. On many applications, an attempt to lift condensate even a few inches will lead to potential flooding or spitting problems from the multiple tube bank. Avoid combined trapping two connections into one steam trap. If traps discharge into a common return, install check valves (low opening pressure) on the outlet of each trap.

Supplying quality steam (not wet) to the humidifier panel is an important component for proper operation. Care must be taken that the main supply header is dripped sufficiently as well as the runout piping to the control valve and header. The entire system must be designed and hooked up to prevent accumulation of condensate at any point. The following recommendations will help to ensure this.

Use drip legs and traps at all low spots or natural drainage points such as:

- Ahead of risers
- End of mains
- Ahead of expansion joints or bends
- Ahead of valves or regulators

Install drip legs and drain traps even where there are no natural drainage points.

Figure 59. Building (boiler) steam panel piping

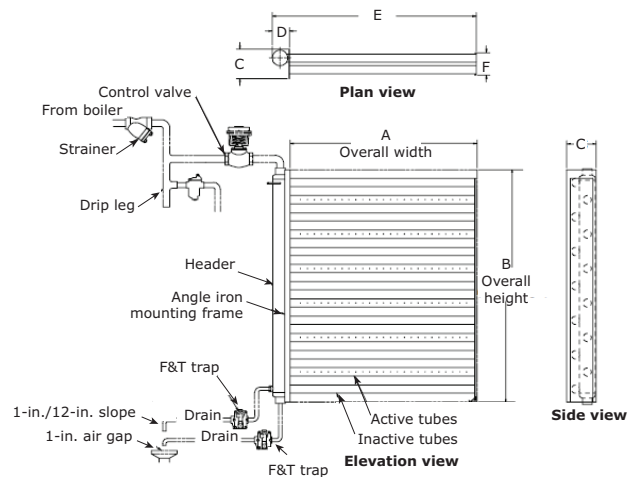



Installation - Electrical

⚠ WARNING

Hazardous Voltage w/Capacitors!

Failure to disconnect power and discharge capacitors before servicing could result in death or serious injury.

Disconnect all electric power, including remote disconnects and discharge all motor start/run capacitors before servicing. Follow proper lockout/tagout procedures to ensure the power cannot be inadvertently energized. For variable frequency drives or other energy storing components provided by Trane or others, refer to the appropriate manufacturer's literature for allowable waiting periods for discharge of capacitors. Verify with a CAT III or IV voltmeter rated per NFPA 70E that all capacitors have discharged.

NOTICE

Use Copper Conductors Only!

Failure to use copper conductors could result in equipment damage as the equipment was not designed or qualified to accept other types of conductors.

If the unit does not include a factory-mounted starter, wiring to the unit fan motor must be provided by the installer and must comply with all national and local electrical codes. The installer must also furnish a service disconnect switch in compliance with national and local electrical codes.

Fan motors require motor overload protective devices that are rated or selected in compliance with the National Electric Code (NEC) or Canadian Electric Code. Specific unit and motor connection diagrams are provided on the starter/VFD if Trane-provided, or refer to the motor nameplate.

If wiring directly to the motor, a flexible connection at the motor to permit fan belt adjustment should be provided. Fractional horsepower motors may be factory connected to a terminal box on the unit. If this construction is provided, the installer should complete field wiring to this connection box. For a typical high voltage wiring schematic, see unit submittal.

All conduit penetrations need to be sealed between the conduit and unit casing with caulk. Between the conductors in the conduit, seal with dust seal, such as Appleton DUC-1, Duct Seal.

On electrical drawings, solid lines indicate factory-installation provided. Dotted lines indicate field-installation.

NOTICE

Leakage!

Failure to follow instructions below could result in equipment damage.

Properly seal all penetrations in unit casing from inner to outer panel in order to prevent unconditioned air from entering the module, as well as prevent water from infiltrating the insulation.

All units with starters or variable-frequency drives (VFDs) that have direct-digital controllers (DDCs) are provided with line voltage to 120 Vac power transformers with power 120 Vac to 24 Vac control transformers. [Figure 60](#) shows a typical VFD power box.

Figure 60. Variable-frequency drive (VFD)



A motor driven by a VFD may operate over 60HZ. Please refer to Job Submittal.

To provide field-wiring to units with DDC or low limit controls:

- If VFD or starter is not factory-mounted, provide 120 Vac power to a transformer in the valve jack when a separate circuit is recommended.
- Install outside-air sensor and space sensor, if ordered.



Start-Up

Pre-Startup Checklist

Once the air handler has been assembled and installed, attention must be directed to individual components for proper operation. Before operating the unit, complete the pre-startup checklist.

⚠ WARNING

Hazardous Voltage w/Capacitors!

Failure to disconnect power and discharge capacitors before servicing could result in death or serious injury.

Disconnect all electric power, including remote disconnects and discharge all motor start/run capacitors before servicing. Follow proper lockout/tagout procedures to ensure the power cannot be inadvertently energized. For variable frequency drives or other energy storing components provided by Trane or others, refer to the appropriate manufacturer's literature for allowable waiting periods for discharge of capacitors. Verify with a CAT III or IV voltmeter rated per NFPA 70E that all capacitors have discharged.

General Checks

- Ensure the unit has been installed level.
- Ensure supply-air and return-air ducts have been connected.
- Ensure damper-operator motors and connecting linkage have been installed.

Note: *Dampers to be secured open. Sudden damper movement may affect air movement and damage dampers, inner walls, and or unit casing.*

- Verify damper operation and linkage alignment.
- Check that air filters are in place and positioned properly.
- Remove any debris from the unit interior.
- Remove all foreign material from the drain pan and check drain pan opening and condensate line for obstructions.
- Close and secure all unit access doors.
- If differential pressure switch is provided on filter rack, adjust per system requirements.
- Inspect electrical connections to the unit and unit controllers.
 - Connections should be clean and secure.
 - Compare the actual wiring with the unit diagrams.
 - Reference the appropriate controller manual for more details about starting units with factory-mounted controls.
- Check piping and valves for leaks. Open or close the valves to check for proper operation. Drain lines should be open.

- Leave this manual with the unit.

Fan-Related Checks

- Verify isolator shipping blocks have been removed.
- Verify fan isolators are adjusted properly.
- If the unit is *not* externally isolated, ensure that the fan isolator tie-down bolts have been removed. See [“Fan Isolation,” p. 30](#) for more information.
- Identify and verify correct fan rotation.
- Rotate all fan wheels manually to confirm they turn freely in the proper direction.
- Check fan shaft bearings, fan wheel, and drive sheave set screws for proper torque settings (see [Table 3 on page 57](#).
 - Fan sheaves should be tight and aligned.
- Check fan drive belt tension. See [section on page 55](#).
- Inspect fan motor and bearings for proper lubrication, if necessary. See [“Fan Bearing Lubrication,” p. 77](#).

Coil-Related Checks

NOTICE

Proper Water Treatment Required!

The use of untreated or improperly treated water could result in scaling, erosion, corrosion, algae or slime. Use the services of a qualified water treatment specialist to determine what water treatment, if any, is required. Trane assumes no responsibility for equipment failures which result from untreated or improperly treated water, or saline or brackish water.

- Ensure coil and condensate drain piping connections are complete.
- Check the piping and valves for leaks.
 - Open or close the valves to check operation.
 - The drain lines should be open.
- If unit has a refrigerant coil, ensure that it has been charged and leak-tested according to the instructions provided with the condenser equipment. Adjust the superheat setting.
- Remove all foreign material from the drain pan and check the pan opening and condensate line for obstructions.
- For steam coils, slowly turn the steam on full for at least 10 minutes before opening the fresh air intake on units with fresh air dampers.

Motor-Related Checks

- Locate installation manual from the motor manufacturer for the specific motor installed. This can be found by contacting the motor manufacturer's representative. The motor manufacturer's recommendations take precedence for all matters related to the start-up and routine maintenance of the motor.
- Check the motor lubrication for moisture and rust.
 - Remove and clean grease plugs to inspect.
 - If moisture is present, consult an authorized repair shop for bearing inspection/replacement. This may require removal and transport of motor.
 - If no moisture is present, refer to the motor manufacturer's lubrication recommendations for proper lubrication.
 - The motor manufacturer may recommend lubricating the motor as part of their routine start-up instructions.
- Check motor winding. An acceptable winding resistance reading is from 6 meg-ohms to infinity. If reading is less than 5 mega-ohms, the winding should be dried out in an oven or by a blower.
- Inspect the entire motor for rust and corrosion.
- Bump-start the unit and confirm the fan wheel rotates properly, as indicated by the rotation arrow located on the fan housing.

Note: For motor warranty needs, contact your local Trane sales office.

Unit Operation

⚠ WARNING

Rotating Components!

Failure to disconnect power before servicing could result in rotating components cutting and slashing technician which could result in death or serious injury. Disconnect all electric power, including remote disconnects before servicing. Follow proper lockout/tagout procedures to ensure the power can not be inadvertently energized.

⚠ WARNING

Live Electrical Components!

Failure to follow all electrical safety precautions when exposed to live electrical components could result in death or serious injury.

When it is necessary to work with live electrical components, have a qualified licensed electrician or other individual who has been properly trained in handling live electrical components perform these tasks.

Before complete start-up, bump-start the unit and confirm the fan wheel rotates properly, as indicated by the rotation arrow located on the fan housing.

After initial startup:

- Calculate the motor voltage imbalance, notifying the power company to correct unacceptable imbalances.
- Periodically check the fan belt tension.

Calculate Motor Voltage Imbalance

After startup, measure the motor voltage and amperage on all phases to ensure proper operation. The readings should fall within the range given on the motor nameplate. The maximum allowable voltage imbalance is 2 percent.

Voltage imbalance is defined as 100 times the sum of the deviation of the three voltages from the average, divided by twice the average voltage. For example, if the three measured voltages are 221, 230 and 227, the average voltage would be 226 volts. The percent of voltage imbalance is then calculated.

$$\text{Voltage imbalance} = \frac{100A}{2 \times \text{AvgVoltage}}$$

where:

$$A = (226-221) + (230-226) + (227-226)$$

$$\text{Voltage imbalance} = 2.2\% \text{ (not acceptable)}$$

In the example, 2.2 percent imbalance is not acceptable and the power company should be notified to correct it.

Tension the Fan Belt

NOTICE

Belt Tension!

Do not over-tension belts. Excessive belt tension will reduce fan and motor bearing life, accelerate belt wear and possibly cause shaft failure. Under tensioning belts is the primary cause of premature belt failure. Belts should not squeal at startup. Recheck belt tension after 8 hours, 24 hours, and 100 hours of operation and monthly thereafter.

Proper belt tension is required to ensure maximum bearing and drive component life and is based on motor horsepower requirement. A label located on the bearing support on the drive side of the unit lists all drive parts, the proper belt tension, and deflection for that tension for the specific drive.

Figure 61. Tension drive belt label

Browning	V-BELT DRIVE KIT	1627373
	MODULE 0400	
PURCHASE ORD. NUMBER B24597-061 H5D073B A		
CUSTOMER'S KIT # H5D073B A-012-0400		
MTR HP.= 10.0		
FAN RPM = 1458 CD = 9.4 AT 3.00 TRN OPN		
TENSION INFO - 3.86 LB., 0.14 IN.		
DRIVE'S BELTS - B40		
MOTOR SHEAVE - 2VP75X 1 3/8		
MOTOR BUSHING - NONE REQUIRED		
FAN SHEAVE - 2B5V80		
FAN BUSHING - B 1 7/16		

If the drive is changed from the original, proper belt tension can be estimated using [Table 2](#).

The correct operation tension for a V-belt drive is the lowest tension at which the belts will not slip under the peak load conditions. It may be necessary, however, to increase the tension of some drives to reduce excessive belt flopping or to reduce excessive startup squealing.

Check the fan belt tension at least three times during the first days of operation because there is a rapid decrease in tension until the belt settles in. To measure belt tension, use a belt tensiometer (see [Figure 62](#)).

Figure 62. Belt tensiometer

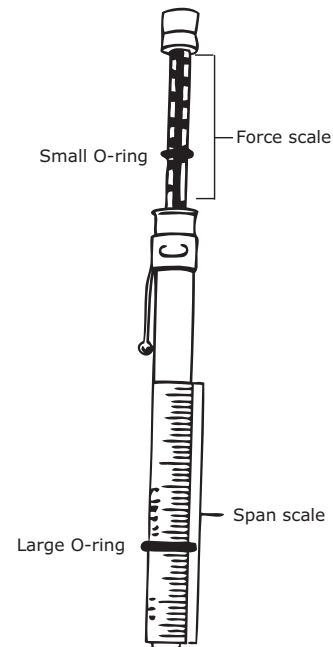

Determine actual deflection by depressing one belt with the belt tensiometer and measuring the deflection relative to the other belts or to belt line (see [Figure 63](#)). Adjust the belt tension to the correct pounds force and tighten all bolts to the proper torque. See [Table 8, p. 77](#).

Figure 63. Belt tension measurement

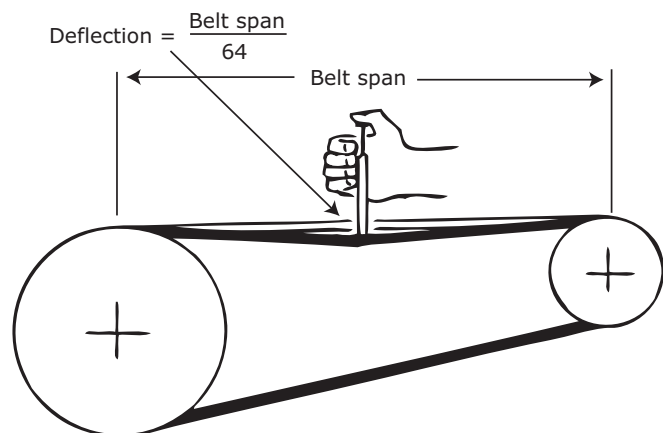

Table 2. Typical sheave diameter and deflection force

Cross section	Smallest sheave diameter range (in.)	Speed (rpm) range	Belt Deflection Force (lbs)			
			Super gripbelts and unnotched gripbands		Gripnotch belts and notched gripbands	
			Used belt	New belt	Used belt	New belt
A, AX	3.0–3.6	1,000–2,500	3.70	5.50	4.10	6.40
		2,501–4,000	2.80	4.20	3.40	5.00
	3.8–4.8	1,000–2,500	4.50	6.80	5.00	7.40
		2,501–4,000	3.80	5.70	4.30	6.40
	5.0–7.0	1,000–2,500	5.40	8.00	5.70	9.40
		2,501–4,000	4.70	7.00	5.10	7.60
B, BX	3.4–4.2	860–2,500	n/a	n/a	4.90	7.20
		2,501–4,000	n/a	n/a	4.20	6.20
	4.4–5.6	860–2,500	5.30	7.90	7.10	10.50
		2,501–4,000	4.50	6.70	7.10	9.10
	5.8–8.6	860–2,500	6.30	9.40	8.50	12.60
		2,501–4,000	6.00	8.90	7.30	10.90
C, CX	7.0–9.0	500–1,740	11.50	17.00	14.70	21.80
		1,741–3,000	9.40	13.80	11.90	17.50
	9.5–16.0	500–1,740	14.10	21.00	15.90	23.50
		1,741–3,000	12.50	18.50	14.60	21.60
D	12.0–16.0	200–850	24.90	37.00	n/a	n/a
		851–1,500	21.20	31.30	n/a	n/a
	18.0–20.0	200–850	30.40	45.20	n/a	n/a
		851–1,500	25.60	38.00	n/a	n/a
3V, 3VX	2.2–2.4	1,000–2,500	n/a	n/a	3.30	4.90
		2,501–4,000	n/a	n/a	2.90	4.30
	2.65–3.65	1,000–2,500	3.60	5.10	4.20	6.20
		2,501–4,000	3.00	4.40	3.80	5.60
	4.12–6.90	1,000–2,500	4.90	7.30	5.30	7.90
		2,501–4,000	4.40	6.60	4.90	7.30
5V, 5VX	4.4–6.7	500–1,749	n/a	n/a	10.20	15.20
		1,750–3,000	n/a	n/a	8.80	13.20
		3,001–4,000	n/a	n/a	5.60	8.50
	7.1–10.9	500–1,749	12.70	18.90	14.80	22.10
		1,750–3,000	11.20	16.70	13.70	20.10
	11.8–16.0	500–1,749	15.50	23.40	17.10	25.50
1,750–3,000		14.60	21.80	16.80	25.00	
8V	12.5–17.0	200–850	33.00	49.30	n/a	n/a
		851–1,500	26.80	39.90	n/a	n/a
	18.0–22.4	200–850	39.60	59.20	n/a	n/a
		851–1,500	35.30	52.70	n/a	n/a

Determine Fan Speed

⚠ WARNING

Live Electrical Components!

Failure to follow all electrical safety precautions when exposed to live electrical components could result in death or serious injury.

When it is necessary to work with live electrical components, have a qualified licensed electrician or other individual who has been properly trained in handling live electrical components perform these tasks.

Fan speed can be determined using a strobe-type tachometer, or revolution counter.

Check unit vibration if the fan speed is changed more than five percent from the original designed speed, or if parts such as shafts, fan wheels, bearings, or other drive components are replaced. Do not exceed the maximum fan speed.

Pay particular attention to any vibration, noise, or overheating of the motor and fan bearings; however, note that bearings may run warm during break in.

Align Fan and Motor Sheaves

Align the fan and motor sheaves using a straightedge. The straightedge must be long enough to span the distance between the outside edges of the sheaves. When the sheaves are aligned, the straightedge will touch both sheaves at points **A** through **D** (see [Figure 64](#)) to confirm the shaft is parallel. For uneven width sheaves, place a string in the center groove of both sheaves and pull tight. Adjust the sheaves and tighten the sheave set screws to the proper torque given in [Table 3](#).

Check Multiple Belts

Tighten the belts slightly and rotate the drive several times.

On multiple belt drives, ensure the force of deflection is approximately the same on each belt by pushing each belt in an equal distance at a point halfway from each sheave (see [Figure 64](#)). If this force is not the same for each belt, the motor and fan shaft are not parallel. Realign as required. After realignment, tighten the belts again to the standard belt tensioning specifications. If the force is still not the same for all belts, the belts or sheaves are worn and must be replaced.

Figure 64. Proper drive alignment

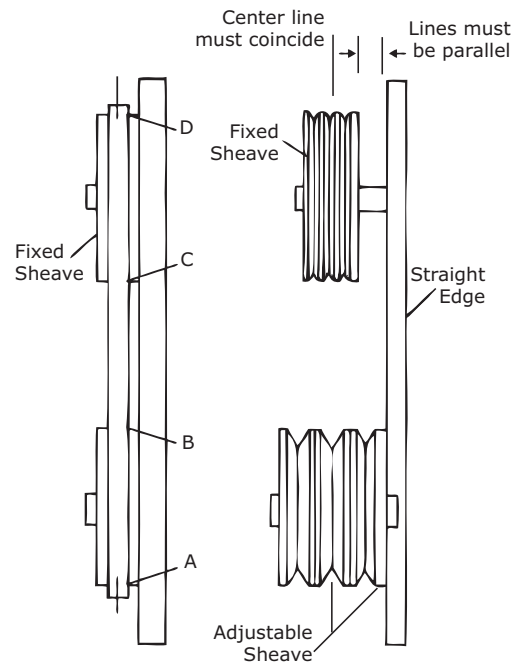

Table 3. Set screw torque settings (inches)

Screw Size	Hex Key	Square Head	Hex Head	Torque (in.-lb.)	Torque (ft.-lb.)
1/4	1/8	3/8	7/16	66-90	5.5-7.5
5/16	5/32	1/2	1/2	126-164	10.5-13.7
3/8	3/16	9/16	9/16	228-300	19.0-25.0
7/16	7/32	5/8	5/8	348-450	29.0-37.5
1/2	1/4	3/4	3/4	504-650	42.0-54.2
5/8	5/16	15/16	15/16	1290-1390	107.0-116.0
#10	3/32	-	-	28-40	2.3-3.3

Airflow Measuring Systems

Traq™ Dampers

Traq dampers are low-leak dampers that modulate and measure airflow. Each Traq damper section is supplied with a factory-mounted ventilation control module (VCM) on the interior of the mixing box section. The VCM has an input terminal for power and an output terminal for air velocity (see [Figure 65](#)). A direct-digital controller controls the factory-mounted and wired actuators.

Figure 65. Traq damper terminal connections

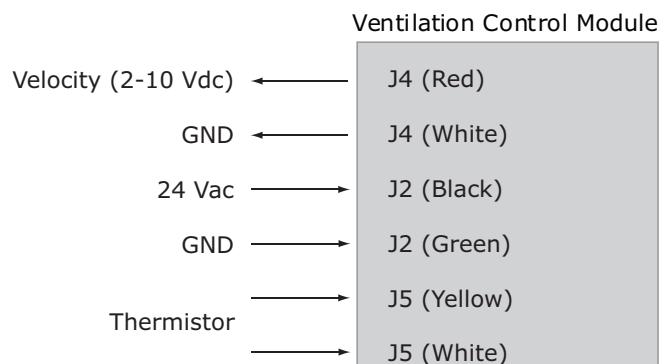
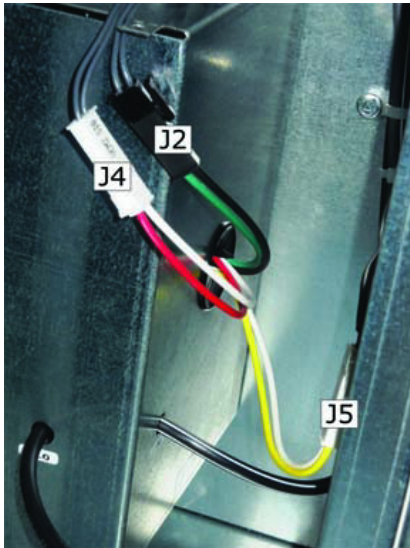

Figure 66. Traq damper terminal connections



VCM (Transducer) Calibration. The VCM has an auto-zero function that recalibrates the transducer once every minute. When troubleshooting, allow for the recalibration time before making any measurements.

Input Power: The only input the VCM needs is the 24 Vac power connected to the J2 plug (green and black wires).

Output Velocity Signal: The 2 to 10 Vdc linear output signal from the VCM represents air velocity. This voltage can be converted to represent airflow (cfm or L/s) using this formula and [Table 4](#).

$$\text{Airflow} = k \text{ (cfm @ 10V)} \left[\frac{(\text{volts} - 2)}{8} \right]$$

or

$$\text{Airflow} = k \text{ (L/s @ 10V)} \left[\frac{(\text{volts} - 2)}{8} \right]$$

For example, if the VCM on a size 30 air handler at sea level (k=1) has a 10-volt signal, it would represent 24,492 cfm (11,559 L/s) through the Traq damper. If the voltage were 6 volts, airflow through the Traq damper would be 12,246 cfm (5779 L/s).

Table 4. Altitude adjustment factors

Sea level = 1.0	
Elevation (feet)	k
1000	0.982
2000	0.964
3000	0.949
4000	0.930
5000	0.914
6000	0.897
7000	0.876
8000	0.860
9000	0.846
10,000	0.825

In [Table 5](#), the cfm at 10Vdc is a calculated value based on area and peak velocity. In certain situations, it can be advantageous to raise the velocity of air through the remaining Traq dampers by closing off one or more dampers in the unit. The cfm at 10Vdc can be recalculated based on the proportion of remaining Traq dampers or by multiplying the remaining area of dampers by peak velocity. Calculations are based on VCM voltage versus airflow at sea level.

Table 5. Back or top inlet Traq dampers - air-mixing and economizer section - VCM voltage versus airflow at sea level

Part Number	Traq Damper Size (inches)	Quantity	Total Area (ft ²)	Peak Velocity (fpm)	CFM @ 10VDC Peak Velocity	L/S @ 10VDC
DMP01123	13	1	0.9213	2500	2303	1087
DMP01124	16	1	1.3956	2650	3698	1745
DMP01663	20	1	2.1806	2650	5779	2727
DMP01125	24	1	3.1400	2700	8478	4001
DMP01126	28	1	4.2739	2700	11540	5446

Fan Inlet Airflow Measuring System

A fan inlet airflow measuring system is available on many centrifugal and plenum fans. Trane's system determines airflow using a static pressure differential.

Note: *This type of system is different than a total pressure or thermal dispersion system. As such, the calculations will be different.*

Each system comes with a differential pressure transmitter. The minimum diameter is connected to the LO port of the transmitter and the reference pressure point is connected to (or actually is) the HI port of the transmitter.

Figure 67. Fan inlet airflow measuring system



Wiring

The transmitter requires 24VDC power on terminals 1 (+) and 2 (ground) of the transmitter. When the airflow measurement system is ordered with a factory-mounted UC600 controller, the 24 VDC power will be supplied.

In the absence of a factory-provided UC600 controller, the installing contractor must ensure the transmitter has 24VDC power.

Transmitter Sizing

Trane specification requires that the flow meter option have a total accuracy of 5 percent. The total accuracy is a combination of:

- how accurately the flow meter is in sensing airflow
- how accurately the transmitter senses the differential pressure
- how accurately the controller translates the signal from the transmitter to a differential pressure.

Selecting the proper transmitter is critical in order to get accurate airflow measurements. How accurately the transmitter senses the differential pressure is dependent on:

- the pressure range selected
- the accuracy of the selected transmitter

Trane air handlers use a 0-5 inch, 0-20 inch, or 0-30 inch w.g. range transmitter as standard. To sufficiently cover VAV turndown on the smallest fans with the above range, a transmitter with an accuracy of 0.25 percent (full scale) is used as standard. If a field-provided transmitter with a lower accuracy is selected, the range should be chosen closer to the actual, maximum pressure differential expected for the application.

The transmitter outputs a signal that represents the differential pressure which is used to calculate airflow. To adequately calculate and display the airflow for the smaller fans, ensure that the analog input is programmed with enough decimal places to sufficiently represent the pressure differential being measured.

The transmitter is factory-calibrated to the range selected and cannot be significantly adjusted to "tighten" the range closer to the pressure being read for the given application.

Transmitter Calibration

The transmitter is factory-calibrated to a specific pressure range with a 0-5 inch, 0-20 inch, or 0-30 inch w.g. range being used in most cases. To check calibration and to adjust if necessary, consult the transmitter manufacturer or the factory for specific procedures.

The transmitter outputs a linear, 2-10 VDC signal representing a differential pressure measurement. With this measurement, the airflow through the fan can be calculated using the following equation:

$$CFM = K * \text{SQRT}(DP)$$

Where:

CFM = Airflow (ft³/min.) assuming a standard air density of 0.075 lbm/ft³.

K = A constant factor that is unique for each fan. See [section on page 59](#) for more information.

DP = Differential pressure (inches w.g.) being measured by the transmitter.

Significant differences in elevation and/or temperature will affect the density of air. For air at a constant, non-standard density, a field-obtained K factor can be used. Alternatively, the following equation can be used to continuously correct the equation above:

$$ACFM = CFM * \text{SQRT}(0.075/\rho)$$

Where:

ACFM = Actual airflow (ft³/min.) corrected for non-standard air density.

ρ = Density (lbm/ft³) of the air at the inlet to the fan.

Note: *Alternative units, including SI, can be used in place of the IP units above although the K-factor must be converted appropriately.*



Constant K-Factors

The constant factor K is unique for each fan and is primarily a function of the area and other geometric properties of the fan

inlet. Pre-engineered factors are available from the factory for fan types where the airflow measurement system is available.

Refer to unit submittals or [Table 6](#) and [Table 7](#) for piezometer K-Factors for our most commonly used fans.

Table 6. Constant K-Factor for twin city fans

Size	Model EPF/EPQ Arrangement 1	Model EPFN/EPQN Arrangement 4	Model BAE DWDI	Model MPQN
122	911.46	944.92		793.96
150	1163.68	1206.40		1189.43
165	1464.80	1518.58		1439.60
182	1757.39	1821.92	3793.22	1821.92
200	2108.38	2185.80	4550.82	2185.80
222	2617.81	2713.93	5650.38	2713.93
245	3168.67	3285.02	6839.38	3285.02
270	3856.03	3997.61	8322.99	3997.61
300	4770.07	4945.21	10,295.89	4945.21
330	5757.23	5968.62	12,426.62	5968.62
365	7032.01	7290.21	15,178.15	7290.21
402	8555.41	8869.55	18,466.31	8869.55
445	10,444.42	10,827.92	22,543.63	10,827.92
490	12,669.80	13,135.01	27,346.98	13,135.01
542	15,541.11	16,111.75	33,544.50	
600	19,004.71	19,702.52	41,020.47	
660	22,994.79	23,839.12	49,632.82	
730	28,128.04	29,160.84	60,712.61	
807			74,233.52	
890			90,279.75	
982			110,113.94	

Table 7. Constant K-Factors for Trane DDP™ fans

Fan Size (inches)/Type	K Factor
10.50 AF direct -drive plenum	576.00
12 AF direct -drive plenum	1238.30
13.50 AF direct -drive plenum	965.00
15 AF direct -drive plenum	1844.50
16 AF direct -drive plenum	2217.30
18 AF direct -drive plenum	1822.00
20 AF direct -drive plenum	2186.00
22 AF direct -drive plenum	2714.00
24 AF direct -drive plenum	3285.00
27 AF direct -drive plenum	3998.00
30 AF direct -drive plenum	4945.00

When a single transmitter is supplied in a multiple fan system, one or more fans will be brought back to the transmitter as a

manifold and the airflow will represent the total airflow for the system. As a result, the factor should be adjusted as follows:

$$K = N * \text{K-Factor from Table 6 and Table 7.}$$

Where:

K = The final factor to be used for controller programming.

N = The number of active* fans in the system.

*If a fan fails in a multiple fan system where only one transmitter is being supplied, and if the remaining fans will continue to be used, the factor should be reduced accordingly. Additionally, if the inactive fan was included in the manifold back to the transmitter, the tubes from the inactive fan should be temporarily removed and replaced with tubes from an active fan (or simply plugged).

When a transmitter is supplied for each fan, the factor does not need to be adjusted. The resulting airflow will represent single-fan airflow. At the controller level, the individual airflows should be summed to get the total airflow. If a field-provided K-factor is to be used (see below), the measured airflow for the system should be divided by the number of active fans to get a single-fan K-factor.

Field-obtained factors can provide maximum accuracy. To obtain the factor in the field, measure the differential pressure output from the transmitter while measuring the airflow through the system. Once these two values have been measured, simply solve for K using the following equation:

$$K = \text{ACFM} / \text{SQRT}(\text{DP})$$

Where:

K = Field-provided constant factor.

ACFM = Actual airflow (ft³/min) being measured at the air density being measured.

DP = Differential pressure (inches w.g.) being measured by the transmitter.

Maintenance

For a typical HVAC environment - especially with upstream filtration - there should be little to no required maintenance. In extreme cases or for mishaps (bearing grease in the taps for example), the flow meter is easily cleanable. The fan inlet airflow measuring system is extremely simple: a few pressure taps, a few fittings, and some tubing. Although unlikely, if any tap were to get clogged, simply disconnect each side of the transmitter and blast air in a reverse direction through the system.

Energy Wheel Startup

⚠ WARNING

Toxic Hazards with Exhaust Air!

Failure to follow this instruction could result in death or serious injury.

Do not use an energy wheel in an application where the exhaust air is contaminated with harmful toxins or biohazards. Using an energy wheel could displace vast quantity of contaminated air which could result in asphyxiation and poisoning.

⚠ WARNING

Hazardous Voltage w/Capacitors!

Failure to disconnect power and discharge capacitors before servicing could result in death or serious injury.

Disconnect all electric power, including remote disconnects and discharge all motor start/run capacitors before servicing. Follow proper lockout/tagout procedures to ensure the power cannot be inadvertently energized. For variable frequency drives or other energy storing components provided by Trane or others, refer to the appropriate manufacturer's literature for allowable waiting periods for discharge of capacitors. Verify with a CAT III or IV voltmeter rated per NFPA 70E that all capacitors have discharged.

NOTICE

Equipment Damage!

Exceeding the recommended airflow can result in damage to equipment. Trane is not responsible for equipment damage resulting from exceeding recommendations.

Do not exceed the maximum rated airflow for the wheel. The pressure drop across the wheel is not to exceed 1.25 inches w.g.

1. Set diameter seals. See ["Energy Wheel Seal Adjustment," p. 76.](#)
2. Turn the energy wheel clockwise (as viewed from the pulley side) by hand to verify that the wheel turns freely through its full rotation.
3. Confirm that all wheel segments are fully engaged in the wheel frame and that segment retainers are completely fastened.

Figure 68. Completely fasten segment retainers

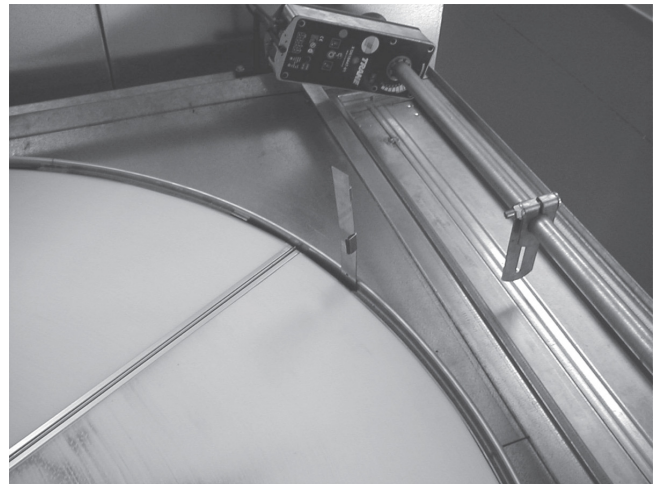

4. With hands and objects away from moving parts, activate the wheel and confirm the wheel rotation. The correct rotation direction is clockwise as viewed from the pulley side.
5. Start and stop the wheel several times to confirm seal adjustment and proper belt tracking on the wheel rim. The correct belt tracking is approximately a quarter inch from the outer edge of the rim.

Figure 69. Confirm proper belt tracking on the wheel rim



6. If the wheel has difficulty starting, turn off the power and inspect for excessive interference between the wheel surface and the four diameter seals. To correct, loosen the diameter seal adjusting screws and back the diameter seals away from the surface of the wheel. Apply power to confirm that the wheel rotates freely. Readjust and tighten the seals according to instructions in [“Energy Wheel Seal Adjustment,”](#) p. 76.
7. Damper actuators (if so equipped): Stroke the actuators to observe full open and full closure of dampers. Adjust the actuator and/or linkage to prevent “over-stroking” so excessive pressure is not placed on the damper at the full open or full closed position.

CDQ Wheel Startup

1. Set seals. See [“CDQ Seal Adjustment,”](#) p. 74.
2. With hands and objects away from moving parts, activate the wheel and confirm the wheel rotation. The correct rotation direction is counter-clockwise as viewed from the pulley side.
3. Verify rotational speed 8-10 rotations per hour. The wheel should be a 1/4 turn in 100-150 seconds.
4. If the wheel has difficulty starting, confirm seals adjustment and belt tension. If belt slips, see [“CDQ Drive Belt Adjustment/Replacement,”](#) p. 73.
5. Start and stop the wheel several times to confirm seal adjustment and proper belt tracking on the wheel rim.

⚠ WARNING

Hazardous Voltage!

Failure to disconnect power before servicing could result in death or serious injury. Disconnect all electric power, including remote disconnects before servicing. Follow proper lockout/tagout procedures to ensure the power can not be inadvertently energized.

6. If the wheel has difficulty starting, turn off the power and inspect for excessive interference between the wheel surface and the four diameter seals. To correct, loosen the diameter seal adjusting screws and back the diameter seals away from the surface of the wheel. Apply power to confirm that the wheel rotates freely. Readjust and tighten the seals according to instructions in [“Energy Wheel Seal Adjustment,”](#) p. 76.
7. Damper actuators (if so equipped): Stroke the actuators to observe full open and full closure of dampers. Adjust the actuator and/or linkage to prevent “over-stroking” so excessive pressure is not placed on the damper at the full open or full closed position.

Note: Do not exceed the maximum rated airflow for the wheel. The pressure drop across the wheel is not to exceed 1.5 inches w.g.

External Insulating Requirements

The following areas should be specifically addressed, as applicable:

- Supply and return water piping connections
- Supply and return refrigerant piping connections
- Condensate drain lines and connections
- Outdoor-air-intake duct connections
- Discharge duct connections
- Special requirements for low-temperature-air systems



Routine Maintenance

⚠ WARNING

Hazardous Service Procedures!

Failure to follow all precautions in this manual and on the tags, stickers, and labels could result in death or serious injury.

Technicians, in order to protect themselves from potential electrical, mechanical, and chemical hazards, **MUST** follow precautions in this manual and on the tags, stickers, and labels, as well as the following instructions: Unless specified otherwise, disconnect all electrical power including remote disconnect and discharge all energy storing devices such as capacitors before servicing. Follow proper lockout/tagout procedures to ensure the power can not be inadvertently energized. When necessary to work with live electrical components, have a qualified licensed electrician or other individual who has been trained in handling live electrical components perform these tasks.

⚠ WARNING

Rotating Components!

Failure to disconnect power before servicing could result in rotating components cutting and slashing technician which could result in death or serious injury. Disconnect all electric power, including remote disconnects before servicing. Follow proper lockout/tagout procedures to ensure the power can not be inadvertently energized.

Maintenance Checklist

Frequency	Maintenance
After 48 hours of operation	For belt-drive fans, the belts have acquired their permanent set. Readjust but do not overtighten. See "Tension the Fan Belt," p. 55 for more information.
Every week	Observe unit weekly for any change in running condition and unusual noise.
Every month	<ul style="list-style-type: none"> • Clean or replace air filters if clogged or dirty; coat permanent filters with oil after cleaning; change bag filters when pressure drop is 1 in. w.g. See the "Filters" section on page 78 for more information. • Belt-drive fans - relubricate fan bearings if necessary. See the "Fan Bearing Lubrication" section on page 77 for more information. Belt-drive fans - check and adjust fan belt tension. See "Tension the Fan Belt," p. 55 for more information.
Every three to six months	<ul style="list-style-type: none"> • Belt-drive fans - check fan bearing grease line connections. Lines should be tight to the bearings. • Check motor bracket torque. See Table 8, p. 77 for torque requirements. • Belt-drive fans - check bearing bolt torque and bearing setscrew torque. See Table 8, p. 77 for torque requirements. • Belt-drive fans - align fan and motor sheaves. Tighten sheave set screws to the proper torque. See "Align Fan and Motor Sheaves," p. 57 for more information. • Inspect and clean drain pans. See the "Drain Pans" section on page 67 for more information. • Tighten electrical connections. • Inspect coils for dirt build-up. See the "Coils" section on page 64 for more information.
Every year	<ul style="list-style-type: none"> • Inspect the unit casing for corrosion. If damage is found, clean and repaint. • Clean the fan wheels and shaft. See the "Fans" section on page 77 for more information. • Inspect and clean drain pans. • Check damper linkages, set screws, and blade adjustment. Clean, but do not lubricate, the nylon damper rod bushings. • Clean damper operators. • Inspect electrical components and insulation. • Inspect wiring for damage. • Rotate the fan wheel and check for obstructions. The wheel should not rub. Adjust the center if necessary. • Lubricate motor bearings in accordance with motor manufacturer's recommendations (see the "Motor Bearing Lubrication" section on page 78 for more information). • Check condition of gasketing and insulation around unit, door and dampers. • Examine flex connections for cracks or leaks. Repair or replace damaged material.

Air-to-Air Plate Heat Exchangers

⚠ WARNING

Hazardous Voltage!

Failure to disconnect power before servicing could result in death or serious injury. Disconnect all electric power, including remote disconnects before servicing. Follow proper lockout/tagout procedures to ensure the power can not be inadvertently energized.

⚠ WARNING

Hazardous Chemicals!

Failure to follow all safety instructions could result in death or serious injury. Coil cleaning agents can be either acidic or highly alkaline and can burn severely if contact with skin occurs. Handle chemical carefully and avoid contact with skin. ALWAYS wear Personal Protective Equipment (PPE) including goggles or face shield, chemical resistant gloves, boots, apron or suit as required. For personal safety refer to the cleaning agent manufacturer's Materials Safety Data Sheet and follow all recommended safe handling practices.

To clean air-to-air heat plate exchangers:

1. Disconnect all electrical power to the unit.
2. Wearing the appropriate personal protective equipment, use a soft brush to remove loose debris from the faces of the exchanger.
3. Install a block-off to prevent spray from going through the exchanger and into a dry section of the unit and/or system ductwork.
4. Mix a high-quality coil cleaning detergent with water according to the manufacturer's instructions.

Note: *If the detergent is strongly alkaline after mixing (PH 8.5 or higher), it must contain an inhibitor. Follow the cleaning solution manufacturer's instructions regarding the use of the product.*

5. Place the mixed solution in a garden pump-up sprayer or high-pressure sprayer. If a high pressure sprayer is used:
 - a. Maintain minimum nozzle spray angle of 15 degrees.
 - b. Spray perpendicular to the exchanger face.
 - c. Use a 40 degree nozzle at least 6 inches from the face.
 - d. Do *not* exceed 1450 psi.
6. Spray the lower sides of the exchanger first, then the upper sides.
7. Thoroughly rinse both sides of the exchanger and the drain pan with cool, clean water.
8. Repeat steps 6 and 7 as necessary.
9. Straighten any plate fins that may have been damaged during the cleaning process.

10. Confirm the drain line is open following the cleaning process.
11. Allow the unit to dry thoroughly before putting it back into service.
12. Replace all panels and parts and restore electrical power to the unit.
13. Be careful any contaminated material does not contact other areas of the unit or building. Properly dispose of all contaminated materials.

Coils

All coils should be kept clean to maintain maximum performance.

Steam and Water Coils

⚠ WARNING

Hazardous Voltage!

Failure to disconnect power before servicing could result in death or serious injury. Disconnect all electric power, including remote disconnects before servicing. Follow proper lockout/tagout procedures to ensure the power can not be inadvertently energized.

⚠ WARNING

Hazardous Chemicals!

Failure to follow all safety instructions could result in death or serious injury. Coil cleaning agents can be either acidic or highly alkaline and can burn severely if contact with skin occurs. Handle chemical carefully and avoid contact with skin. ALWAYS wear Personal Protective Equipment (PPE) including goggles or face shield, chemical resistant gloves, boots, apron or suit as required. For personal safety refer to the cleaning agent manufacturer's Materials Safety Data Sheet and follow all recommended safe handling practices.

To clean steam and water coils:

1. Disconnect all electrical power to the unit.
2. Wearing the appropriate personal protective equipment, use a soft brush to remove loose debris from both sides of the coil.
3. Install a block-off to prevent spray from going through the coil and into a dry section of the unit and/or system ductwork.
4. Mix a high-quality coil cleaning detergent with water according to the manufacturer's instructions.

Note: *If the detergent is strongly alkaline after mixing (PH 8.5 or higher), it must contain an inhibitor. Follow the cleaning solution manufacturer's instructions regarding the use of the product.*

5. Place the mixed solution in a garden pump-up sprayer or high-pressure sprayer. If a high pressure sprayer is to be used:
 - Maintain minimum nozzle spray angle of 15 degrees.
 - Spray perpendicular to the coil face.
 - Keep the nozzle at least 6 inches from the coil.
 - Do *not* exceed 600 psi.
6. Spray the leaving air side of the coil first, then the entering air side.
7. Thoroughly rinse both sides of the coil and the drain pan with cool, clean water.
8. Repeat steps 6 and 7 as necessary.
9. Straighten any coil fins that may have been damaged during the cleaning process.
10. Confirm the drain line is open following the cleaning process.
11. Allow the unit to dry thoroughly before putting it back into service.
12. Replace all panels and parts and restore electrical power to the unit.
13. Be careful any contaminated material does not contact other areas of the unit or building. Properly dispose of all contaminated materials.

Refrigerant Coils

WARNING

Hazardous Pressures!

Failure to follow these safety precautions could result in coil bursting, which could result in death or serious injury.

Coils contain refrigerant under pressure. When cleaning coils, maintain coil cleaning solution temperature under 150°F to avoid excessive pressure in the coil.

WARNING

Hazardous Voltage!

Failure to disconnect power before servicing could result in death or serious injury.

Disconnect all electric power, including remote disconnects before servicing. Follow proper lockout/tagout procedures to ensure the power can not be inadvertently energized.

WARNING

Hazardous Chemicals!

Failure to follow all safety instructions could result in death or serious injury.

Coil cleaning agents can be either acidic or highly alkaline and can burn severely if contact with skin occurs. Handle chemical carefully and avoid contact with skin. ALWAYS wear Personal Protective Equipment (PPE) including goggles or face shield, chemical resistant gloves, boots, apron or suit as required. For personal safety refer to the cleaning agent manufacturer's Materials Safety Data Sheet and follow all recommended safe handling practices.

To clean refrigerant coils:

1. Disconnect all electrical power to the unit.
2. Wearing the appropriate personal protective equipment, use a soft brush to remove loose debris from both sides of the coil.
3. Install a block-off to prevent spray from going through the coil and into a dry section of the unit and/or system ductwork.
4. Mix a high-quality coil cleaning detergent with water according to the manufacturer's instructions.

Note: *If the detergent is strongly alkaline after mixing (PH 8.5 or higher), it must contain an inhibitor. Follow the cleaning solution manufacturer's instructions regarding the use of the product.*

5. Place the mixed solution in a garden pump-up sprayer or high-pressure sprayer. If a high pressure sprayer is to be used:
 - Maintain minimum nozzle spray angle of 15 degrees.
 - Spray perpendicular to the coil face.
 - Keep the nozzle at least 6 inches from the coil.
 - Do *not* exceed 600 psi.
6. Spray the leaving air side of the coil first, then the entering air side.
7. Thoroughly rinse both sides of the coil and the drain pan with cool, clean water.
8. Repeat steps 6 and 7 as necessary.
9. Straighten any coil fins damaged during the cleaning process.
10. Confirm the drain line is open following the cleaning process.
11. Allow the unit to dry thoroughly before putting it back into service.
12. Replace all panels and parts and restore electrical power to the unit.
13. Be careful any contaminated material does not contact other areas of the unit or building. Properly dispose of all contaminated materials and cleaning solution.



Routine Maintenance

Coil Winterization

Water coil winterization procedures consist primarily of draining water from the coil before the heating season. Trane recommends flushing the coil with glycol if coils will be exposed to temperatures below 35 degrees.

NOTICE

Coil Freeze-up!

Failure to do so could result in equipment damage. Drain and vent coils when not in use. Trane recommends glycol protection in all possible freezing applications. Use a glycol approved for use with commercial cooling and heating systems and copper tube coils.

Install field-fitted drains and vents to permit winterization of coils not in use and to assist in evacuating air from the water system during startup. If draining is questionable because of dirt or scale deposits inside the coil, fill the coil with glycol before the heating season begins.

Individual coil types determine how to properly winterize the coil. To determine the coil type find the "Service Model No of Coil" on the coil section nameplate. The coil type is designated by the second and third digits on that model number. For example, if the model number begins with "DUWB," the coil type is UW; if the model number begins with "DW0B," the coil type is W.

Note: *On many unit sizes, there are multiple coils in the coil section. Be sure to winterize all coils in a given coil section.*

To winterize type D1, D2, WL, LL, UA, UW, UU, W, P2, P4, P8, WD, 5D, and 5W coils:

1. Remove the vent and drain plugs.
2. Blow the coil out as completely as possible with compressed air.
3. Fill and drain the coil several times with full strength glycol so that it mixes thoroughly with the water retained in the coil.
4. Drain the coil out as completely as possible.
5. To ensure no water remains in the coil, do not replace the vent and drain plugs until the coils are put back into service.

Note: *Use care in removing header plugs from Type P2, P4, and P8 coils. Over-torquing may result in twisted tubes.*

Moisture Purge Cycle

By its very nature, any HVAC unit with a cooling coil serves as a dehumidifier, reducing the surrounding air's ability to hold water vapor as its temperature falls. This normally doesn't present a problem when the unit is running. However, when the fan stops, water vapor condenses on the cold metal surfaces inside the air handler and remains there until the air warms sufficiently to re-evaporate it. This damp, dark environment—though temporary—can encourage the growth of mold, mildew, and other microbial contaminants.

Providing a moisture purge cycle 15 to 30 minutes after shutdown disperses the cold, humid air inside the air-handling system more evenly throughout the building. This four-step cycle:

- Closes the outdoor air dampers.
- Turns off the cooling coil.
- Opens any variable-air-volume terminals connected to the air handler.
- Operates the supply fan for 10 to 15 minutes.

Air movement discourages water condensation and hastens re-evaporation of any condensate that does happen to form. This simple preventative measure effectively combats microbial growth and curbs moisture-related deterioration of air-handling components.

Cleaning Non-Porous Surfaces

⚠ WARNING

Hazardous Voltage!

Failure to disconnect power before servicing could result in death or serious injury. Disconnect all electric power, including remote disconnects before servicing. Follow proper lockout/tagout procedures to ensure the power can not be inadvertently energized.

If microbial growth on a non-porous insulating surface (closed cell insulation or sheet metal surface) is observed:

1. Disconnect all electrical power to the unit.
2. Wearing the appropriate personal protective equipment, use a brush for sheet metal surfaces or a soft sponge on a foil face or closed cell foam surface to mechanically remove the microbial growth.

Note: *Be careful not to damage the non-porous surface of the insulation.*

3. Install a block-off to prevent spray from going into a dry section of the unit and/or system ductwork.
4. Thoroughly clean the contaminated area(s) with an EPA-approved sanitizer specifically designed for HVAC use.
5. Rinse the affected surfaces thoroughly with fresh water and a fresh sponge to prevent potential corrosion of the drain pan and drain line

- Repeat steps 4 and 5 as necessary.
- Confirm the drain line is open following the cleaning process.
- Allow the unit to dry thoroughly before putting it back into service.
- Replace all panels and parts and restore electrical power to the unit.
- Be careful any contaminated material does not contact other areas of the unit or building. Properly dispose of all contaminated materials and cleaning solution.

Cleaning Porous Surfaces

⚠ WARNING

Hazardous Voltage!

Failure to disconnect power before servicing could result in death or serious injury.

Disconnect all electric power, including remote disconnects before servicing. Follow proper lockout/tagout procedures to ensure the power can not be inadvertently energized.

To clean a porous insulating surface (fiberglass insulation):

- Disconnect all electrical power to the unit.
- Wearing the appropriate personal protective equipment, use a vacuum device with a HEPA filter (99.97 percent efficient at 0.3 micron particles) to remove the accumulated dirt and organic matter.
Note: *Be careful not to tear the insulation surface or edges.*
- Confirm the drain line is open following the cleaning process.
- Allow the unit to dry thoroughly before putting it back into service.
- Replace all panels and parts and restore electrical power to the unit.
- Be careful any contaminated material does not contact other areas of the unit or building. Properly dispose of all contaminated materials and cleaning solution.

Drain Pans

⚠ WARNING

Hazardous Chemicals!

Failure to follow all safety instructions could result in death or serious injury.

Coil cleaning agents can be either acidic or highly alkaline and can burn severely if contact with skin occurs. Handle chemical carefully and avoid contact with skin. ALWAYS wear Personal Protective Equipment (PPE) including goggles or face shield, chemical resistant gloves, boots, apron or suit as required. For personal safety refer to the cleaning agent manufacturer's Materials Safety Data Sheet and follow all recommended safe handling practices.

⚠ WARNING

No Step Surface!

Failure to follow this recommendation could result in death or serious injury.

Do not walk on the sheet metal drain pan. Walking on the drain pan could cause the supporting metal to collapse, resulting in the operator/technician to fall.

The condensate drain pan and drain line must be checked to assure the condensate drains as designed. This inspection should occur a minimum of every six months or more often as dictated by operating experience.

If evidence of standing water or condensate overflow exists, identify and remedy the cause immediately. Refer to ["Troubleshooting," p. 81](#) for possible causes and solutions.

To clean drain pans:

- Disconnect all electrical power to the unit.
- Wearing the appropriate personal protective equipment, remove any standing water.
- Scrape solid matter off of the drain pan.
- Vacuum the drain pan with a vacuum device that uses high-efficiency particulate arrestance (HEPA) filters with a minimum efficiency of 99.97 percent at 0.3 micron particle size.
- Thoroughly clean any contaminated area(s) with a mild bleach and water solution or an EPA-approved sanitizer specifically designed for HVAC use.
- Immediately rinse the affected surfaces thoroughly with fresh water and a fresh sponge to prevent potential corrosion of metal surfaces.
- Allow the unit to dry completely before putting it back into service.
- Be careful any contaminated material does not contact other areas of the unit or building. Properly dispose of all contaminated materials and cleaning solution.
- Check filters. Dirty filters will raise static pressure and may affect the operation of the drain pan p-trap.

CDQ Desiccant Dehumidification Wheel

Cleaning the CDQ Section

If there is dirt or dust buildup in the wheel, clean the wheel using the following procedure:

Vacuuming the wheel

1. Disconnect all power.
2. Using a standard shop vacuum, vacuum any debris from both faces of the wheel. Slowly work around the entire face of the wheel to complete the procedure. Do not damage wheel face by excessive pressure of the vacuum nozzle on the wheel face.
3. Using 20 psig clean dry air, and a small air nozzle, blow air through one face of the wheel. At a similar location on the opposite side of the wheel, gently apply a shop vacuum to "receive" any remaining debris exiting the wheel.

In most instances this should adequately clean the wheel. In the event the wheel is subject to an aerosol, smoke or other material that coats the wheel, it can be washed with water and/or a mild detergent. The desiccant wheel can be washed thoroughly without affecting the performance of the wheel. The wheel will simply dry out following a washing procedure and resume dehumidification without any deviation in performance.

If the desiccant wheel can be easily removed from the cassette or unit, it is recommended to do so to facilitate the washing process. However, in most cases, it is impractical to remove larger wheels and therefore, the washing procedure must take place within the air handling unit and provisions need to be made to collect the runoff water from the bottom of the unit.

Washing the wheel

1. Disconnect all power.
2. Shield or remove all electrical components with plastic sheeting. Shield the bearing with plastic sheeting. Precautions should be taken to ensure the motor windings and capacitor do not get wet.
3. Ensure that an adequate drainage system exists to collect runoff water from the bottom of the unit.
4. Using standard pressure water (do not use a high pressure washer) and working from the lower half of the wheel, wash the wheel with a standard "garden" nozzle to flush any debris trapped within the flutes of the wheel. Minimize water contact with the seals. Wash from one side and vacuum up water from the other side with a wet vacuum.
5. Once the entire process side is adequately washed, rotate the wheel one half turn and wash the section that was at the top.
6. After washing, there will be a temporary derate in performance as the wheel dries out. To expedite the dry out time, regeneration preheat should be activated if it was provided.

Cleaning the Motor

⚠ WARNING

Hazardous Voltage!

Failure to disconnect power before servicing could result in death or serious injury. Disconnect all electric power, including remote disconnects before servicing. Follow proper lockout/tagout procedures to ensure the power can not be inadvertently energized.

Disconnect all electrical power, then use a vacuum cleaner and brush to remove accumulated material from the CDQ wheel motor. The use of spray aerosol cleaners is not recommended. Examine the motor monthly for debris accumulation.

Cleaning the Module

1. Disconnect all electrical power.
2. Use a vacuum cleaner to remove dust and debris from the module surfaces.
3. If needed, use a detergent solution to remove grease, oil, or other stubborn deposits from module surfaces. Follow the manufacturer's instructions regarding use of the product.
4. Rinse any cleaning product thoroughly from the module walls. The use of a water stream from a garden hose or high pressure washer is *not* recommended. Saturation of the wall panel insulation could result in potential microbial growth.
5. Examine the module monthly for material build-up on the wall surfaces.

CDQ Service and Repair

CDQ Bearing and Motor Lubrication

The wheel gear motor bearings are pre-lubricated at the manufacturer and do not require re-lubrication. Wheels smaller than 8500 cfm, 66-inches in diameter, have a permanently sealed inboard bearing and need no maintenance. Larger wheels come equipped with an external flanged bearing that should be greased annually.

CDQ Drive Belt Tension

The drive belt is a link stretch belt designed to provide tension throughout the life of the belt. Inspect the belt annually for proper tracking and tension. A properly tensioned belt will turn the wheel immediately, with no visible slippage, when power is applied. If belt needs tensioning, see "[CDQ Drive Belt Adjustment/Replacement](#)" on page 73.

CDQ Bearing Replacement

⚠ WARNING

Hazardous Voltage!

Failure to disconnect power before servicing could result in death or serious injury. Disconnect all electric power, including remote disconnects before servicing. Follow proper lockout/tagout procedures to ensure the power can not be inadvertently energized.

CDQ Internal Bearing Replacement

Prepare wheel for removal of old bearing and installation of new bearing.

1. Remove belt from motor and wheel.
2. Support wheel with wooden blocks on both sides of the wheel.

Figure 70. Wooden blocks support wheel

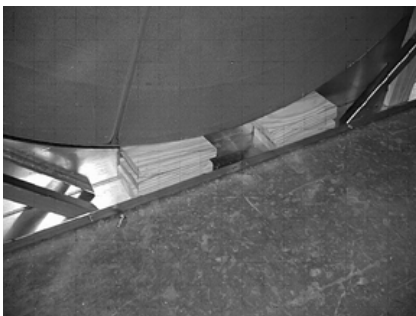

3. Make sure the wheel is secure. The short posts are removed first.

Figure 71. Remove short posts first

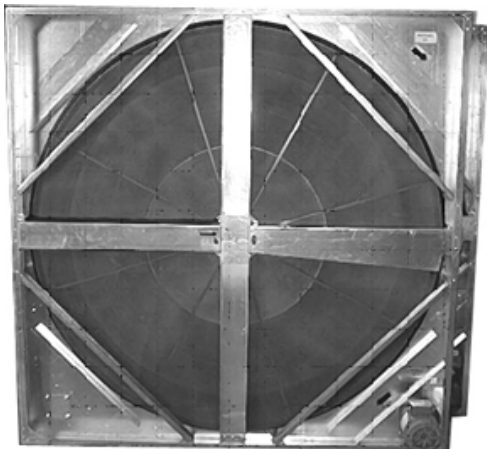

4. To prevent wheel from flipping out, cut two 1-inch x 4-inch boards for placement across the face and behind the lip and corner braces on the cassette.

Figure 72. Prevent wheel from flipping out with boards

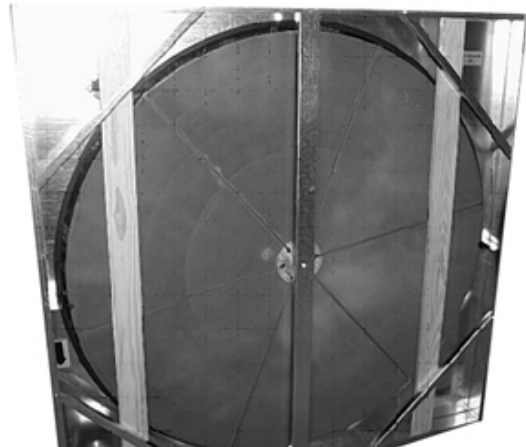

5. Remove the post mounting screws or bolts at both ends of the long post.

Figure 73. Remove post mounting screws



6. Remove the shaft bolt.

Figure 74. Remove shaft bolt

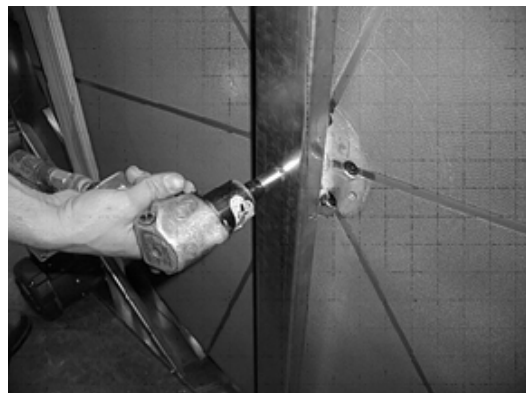

7. Remove the post.

Figure 75. Remove post

8. Remove the snap ring from the shaft.

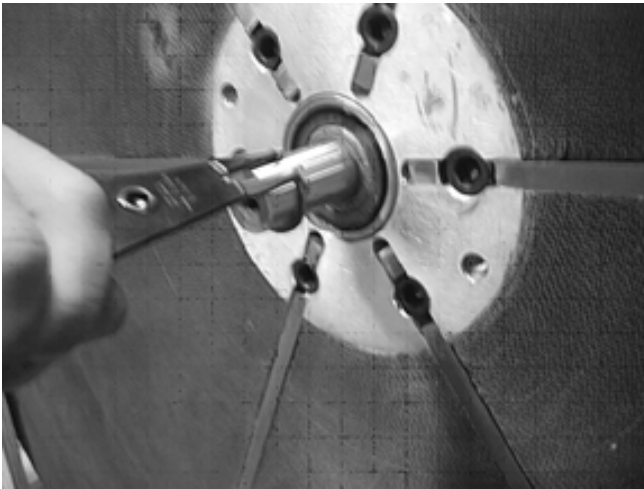
Figure 76. Remove snap ring

9. Remove shaft bolt, post and snap ring from opposite side using the same procedure. Remove shaft, being careful not to damage it. You may want to install a short bolt in the end of the shaft and tap the bolt to remove shaft.
10. The old bearing is removed by tapping it from the back using a rod or punch passed through the other bearing. It is best to use brass or other soft metal, but if bearing is being replaced, it is okay to use a steel rod. Gently work around the race with a series of gentle taps. Using excessive force can cock the bearing and make removal difficult and/or damage the aluminum hub. Once one bearing is out, go to the other side and repeat procedure to remove the other bearing.

Figure 77. Remove old bearing by tapping from the back. Gently tap around the race. Repeat on opposite side.

Figure 77. Remove old bearing by tapping from the back. Gently tap around the race. Repeat on opposite side.

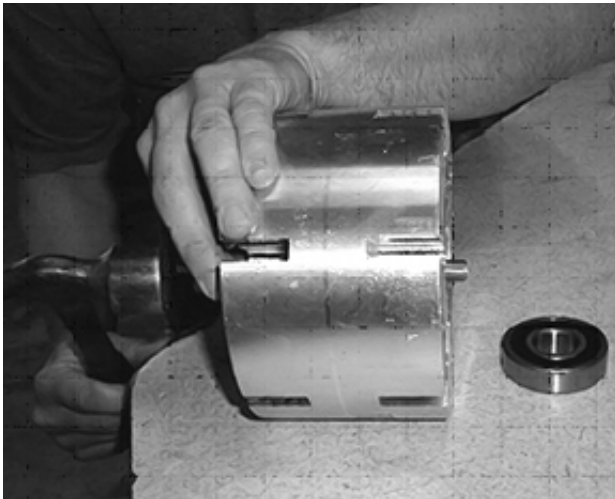

Figure 78. Tap outer race of new bearing, alternating sides



11. Clean the hub and new bearing races before installing
12. Gently tap the outer race of the new bearings into the hub using a hammer, making sure that the bearing is not cocked. It is best to alternate to opposite sides of the race as shown in the two pictures at right. Do not strike the inner race of the bearing or it may be damaged.

13. Repeat the procedure for the other bearing.
14. Install one snap ring on the shaft and gently slide the shaft through the bearings. It may be necessary to tap it gently with a hammer.
15. After the shaft is through the bearings and snap ring is against the inner race, install the other snap ring.
16. Install the long post on one side and re-install the shaft bolt.
17. Install the long post on the other side and re-install the shaft bolt.
18. Install the short posts.
19. Check the wheel for rotation and insure that is centered in the cassette. It may be necessary to loosen the shaft bolts and adjust the wheel so that it is equidistant from posts on both sides.

Figure 79. Exploded view of internal bearing and shaft assembly (no hub shown)

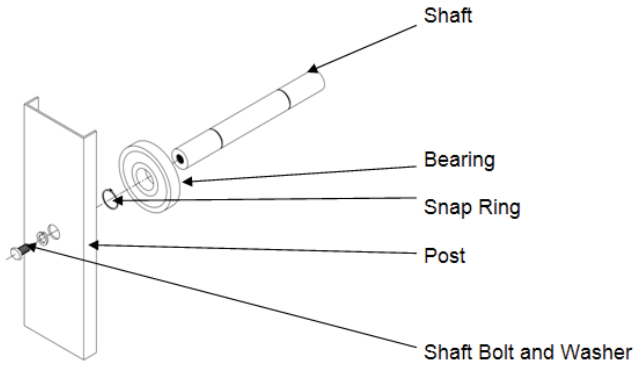

20. Install the belt.
21. Start up unit and check wheel for clearance. Seals on the short posts may have to be adjusted for proper sealing.

CDQ External Bearing Replacement

Prepare wheel for removal of old bearing and installation of new bearing.

1. Remove belt from motor and wheel.
2. Support wheel with wooden blocks on both sides of the wheel.

Figure 80. Wooden blocks support wheel

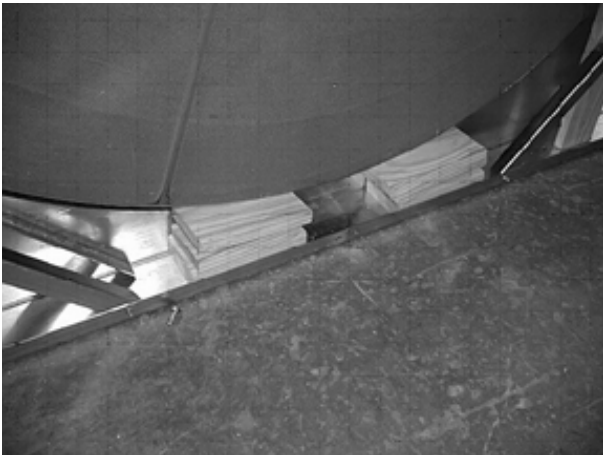

3. Remove cover plate from bearing housing if present.

Figure 81. Remove cover plate

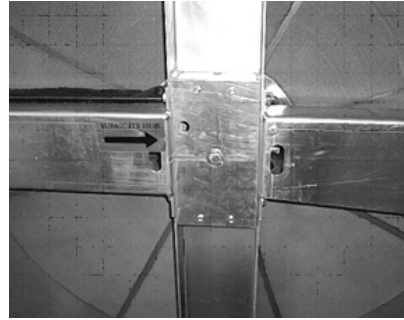

4. Remove the bolt and washer from the end of the shaft.

Figure 82. Remove bolt and washer from shaft.

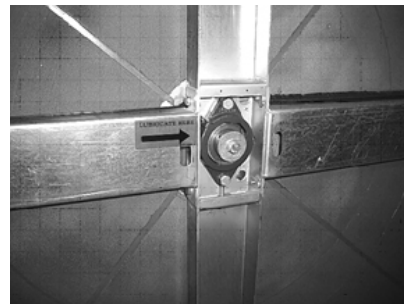

5. Loosen the set screws in the bearing inner race.

Figure 83. Loosen set screws



- Remove the bolts securing the bearing to the cassette.

Figure 84. Remove bolts securing bearing

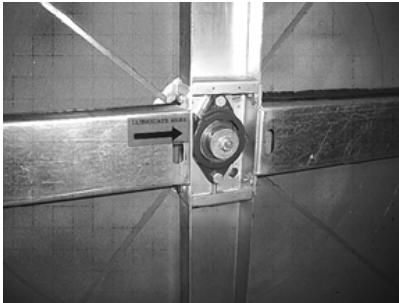

- Remove the bearing. Use a bearing puller if necessary.
- Clean shaft and install new bearing on shaft, insuring that set screws line up with flats on the shaft.
- Install bearing mounting bolts. It may be necessary to move wheel up or down to align bolts. The easiest method is to apply pressure at the top of the wheel. Using a 1-foot by 1-foot square of 1/2-inch thick plywood on the face will spread the force enough to prevent damage to the media face while pushing on the top of the wheel. The other method of lifting the wheel is to use a pry bar at the bottom, taking care to only apply force at a spoke to prevent bending the band.

Figure 85. Install bearing mounting bolts

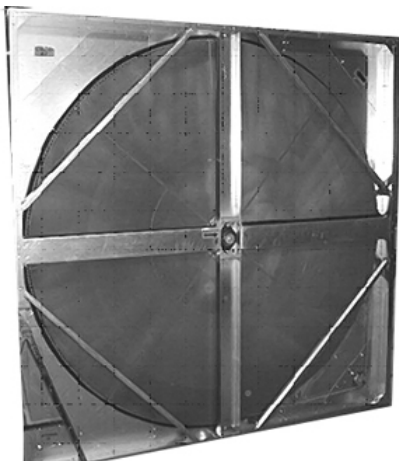

- Tighten the bearing mounting bolts.
- Check alignment of the set screws and tighten to the specifications provided in the literature with the bearing.
- Rotate the wheel and make sure that it is aligned in the cassette so that the face is equidistant from each post. If not, loosen the bearing mounting bolts and adjust as necessary. Flange bearing units have jack bolts. See [Figure 86](#).

Figure 86. Typical flange bearing, shaft and hub assembly

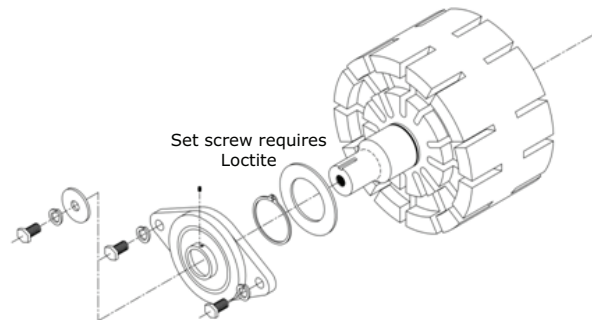

- Pillow block bearing units require shims to adjust the bearing up or down. See [Figure 87](#). Retighten bearing mounting bolts once alignment is correct.
- Install bearing cover plates. Remove blocks supporting wheel. Install belts.

Figure 87. Typical pillow block bearing, shaft and hub assembly

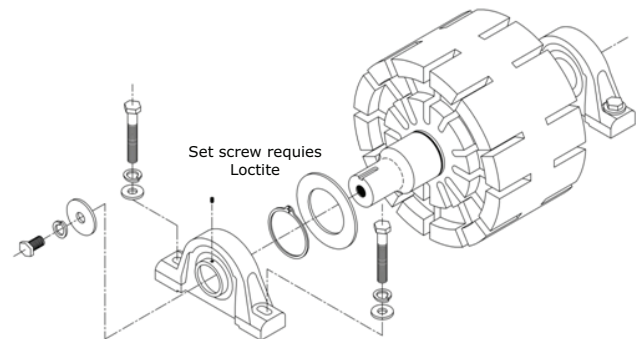

CDQ Drive Belt Adjustment/Replacement

The CDQ wheel uses a link belt that has no tension devices that need adjustment. Tension the belt by adjusting the number to links in the belt. If the belt becomes too loose it can be tighten by removing a link from the belt.

⚠ WARNING

Hazardous Voltage!

Failure to disconnect power before servicing could result in death or serious injury. Disconnect all electric power, including remote disconnects before servicing. Follow proper lockout/tagout procedures to ensure the power can not be inadvertently energized.

CDQ Belt Tension

1. Disconnect all power to the desiccant wheel.
2. Slip belt off of drive pulley.
3. Hold the belt with tabs facing outward as shown in [Figure 88](#), twist tab and push through one link.

Figure 88. Hold belt with tabs facing outward



4. Twist the next tab and push through the two links as shown in [Figure 89](#).

Figure 89. Twist and push through links



5. Remove one link.
6. Reconnect the belt as shown in [Figure 90](#).

- a. Push tab through
- b. Align belt
- c. Flex second tab through

Figure 90. Reconnect the belt

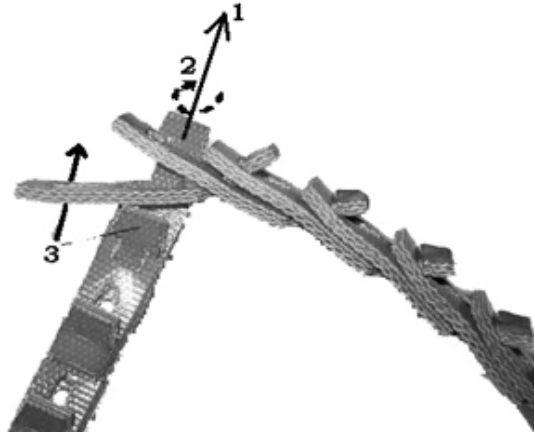

CDQ Seal Adjustment

Neoprene brush seals are located on both sides of the cassette around the wheel perimeter and the center diameter posts. The seals are designed to come in contact with the wheel and require no maintenance other than adjustment. The seals consist of a metal and neoprene clip that grips to the metal posts or panels. These clips can be manually adjusted.

Figure 91. Seals are located around wheel perimeter and center of diameter posts

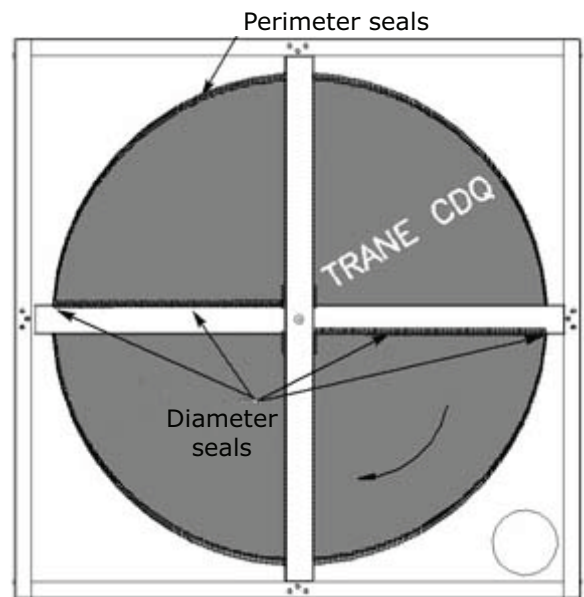

To minimize air that bypasses the wheel the perimeter seals should be adjusted such that air gaps are not visible around the wheel. Do not over compress the seal against the perimeter as this may cause the wheel not to turn or overload the motor. To minimize air the leaks from one side to the next the diameter

seals should be adjusted to come in full contact with the wheel face.

Figure 92. Adjust seals to fully contact wheel face to minimize leaks

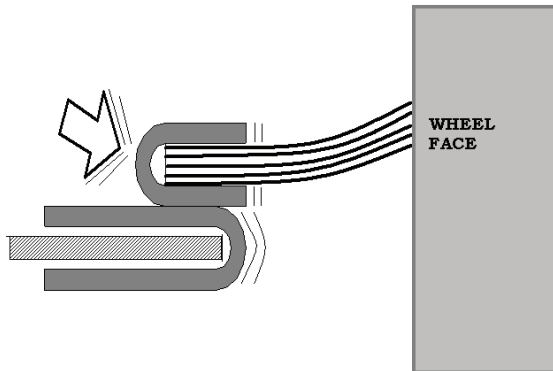

CDQ Drive Motor and Pulley Replacement

1. Disconnect all electrical power.
2. Remove the belt from the pulley and temporarily position it around the wheel rim.
3. Measure and record the distance from the inner edge of the pulley to the mounting wall.
4. Loosen the set screw in the wheel drive pulley using an Allen wrench and remove the pulley from the motor drive shaft.
5. While supporting the weight of the drive motor in one hand, loosen and remove the four mounting bolts.
6. Install a replacement motor with the hardware kit supplied.
7. Install the pulley and adjust it to the distance recorded in the previous step.
8. Tighten the set screw to the drive shaft.
9. Stretch the belt over the pulley and engage it in the groove.

Energy Wheels

⚠ WARNING

Hazardous Voltage!

Failure to disconnect power before servicing could result in death or serious injury. Disconnect all electric power, including remote disconnects before servicing. Follow proper lockout/tagout procedures to ensure the power can not be inadvertently energized.

NOTICE

Equipment Damage!

Failure to follow instructions below could result in wheel damage. Do not use acid based cleaners, aromatic solvents, steam, or temperatures in excess of 170°F to clean the wheel. Do not use a pressure washer to clean energy wheel segments.

NOTICE

Reduced Airflow!

Accumulated dirt and debris may result in reduced airflow and/or increased pressure drop across the energy wheel. Increased pressure drop can result in permanent damage to the energy wheel. Trane is not responsible for equipment-only-damage caused by debris.

Cleaning the Energy Wheel

Disconnect all electrical power, then use a vacuum or brush to remove accumulated material from the face of the wheel. Examine the energy wheel monthly for material build-up on the wheel.

If more aggressive cleaning is needed, consult manufacturer's instructions.

Cleaning Frequency

In reasonably clean office or school buildings, cleaning with a solution may not be required for several years. If the energy wheel is exposed to air streams containing, for example, high levels of occupant tobacco smoke, cooking facility exhaust air, or oil-based aerosols found in machine shop areas, annual cleaning may be required to remove these contaminants and restore performance.

Energy Wheel Bearing and Motor Lubrication

The wheel drive motor and wheel support shaft bearings are permanently lubricated and no further lubrication is necessary.

Energy Wheel Drive Belt Adjustment

The drive belt is a urethane stretch belt designed to provide constant tension throughout the life of the belt. No periodic adjustment is required. Inspect the belt annually for proper tracking and tension. A properly tensioned belt will turn the wheel immediately, with no visible slippage, when power is applied.

⚠ CAUTION

Sharp Edges!

Failure to follow recommendations could result in minor to moderate injury.

The service procedure described in this document involves working around sharp edges. To avoid being cut, technicians **MUST** put on all necessary Personal Protective Equipment (PPE), including gloves and arm guards.

Energy Wheel Seal Adjustment

1. Loosen the diameter seal adjustment screws and back the seals away from the wheel surface.

Figure 93. To adjust seal, loosen screws, back seals away from wheel surface. Seal seen from bottom section.

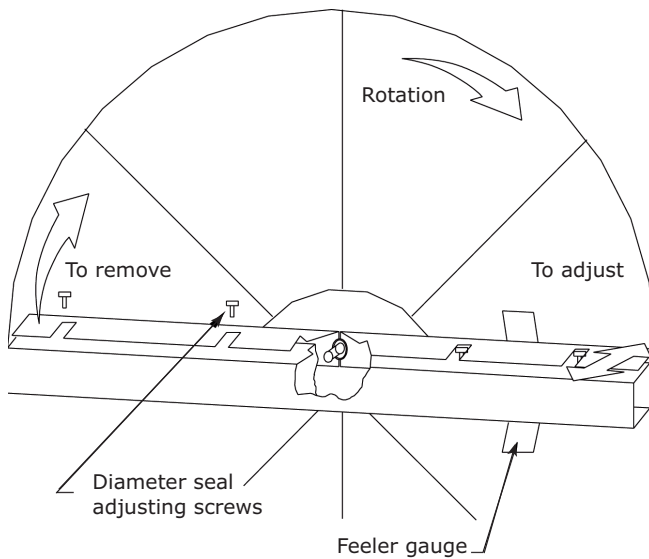

1. Rotate the wheel clockwise until two opposing spokes are hidden behind the bearing support beam.
2. Using a folded piece of paper as a feeler gauge, position the paper between the wheel surface and the diameter seals.
3. Adjust the seals toward the wheel surface until slight friction on the paper feeler gauge is felt when the gauge is moved along the length of the spoke.
4. Check the adjustment through a full rotation of the wheel.
5. Retighten the adjusting screws and recheck the clearance with the paper feeler gauge.

Energy Wheel Drive Motor and Pulley Replacement

⚠ WARNING

Hazardous Voltage!

Failure to disconnect power before servicing could result in death or serious injury. Disconnect all electric power, including remote disconnects before servicing. Follow proper lockout/tagout procedures to ensure the power can not be inadvertently energized.

1. Disconnect all electrical power.
2. Remove the belt from the pulley and temporarily position it around the wheel rim.
3. Measure and record the distance from the inner edge of the pulley to the mounting wall.
4. Loosen the set screw in the wheel drive pulley using an Allen wrench and remove the pulley from the motor drive shaft.
5. While supporting the weight of the drive motor in one hand, loosen and remove the four mounting bolts.
6. Install a replacement motor with the hardware kit supplied.
7. Install the pulley and adjust it to the distance recorded in the previous step.
8. Tighten the set screw to the drive shaft.
9. Stretch the belt over the pulley and engage it in the groove.

Fans

⚠ WARNING

Rotating Components!

Failure to disconnect power before servicing could result in rotating components cutting and slashing technician which could result in death or serious injury. Disconnect all electric power, including remote disconnects before servicing. Follow proper lockout/tagout procedures to ensure the power can not be inadvertently energized.

Inspecting and Cleaning Fans

Fan sections of air handlers should be inspected every six months at a minimum or more frequently if operating experience dictates. If evidence of microbial growth (mold) is found, identify and remedy the cause immediately. Refer to "Troubleshooting," p. 81 for possible causes and solutions. To clean the fan section:

1. Disconnect all electrical power to the unit.
2. Wearing the appropriate personal protective equipment, remove any contamination.
3. Vacuum the section with a vacuum device that uses high-efficiency particulate arrestance (HEPA) filters with a minimum efficiency of 99.97 percent at 0.3 micron particle size.
4. Thoroughly clean any contaminated area(s) with a mild bleach and water solution or an EPA-approved sanitizer specifically designed for HVAC use.
5. Immediately rinse the affected surfaces thoroughly with fresh water and a fresh sponge to prevent potential corrosion of metal surfaces.
6. Allow the unit to dry completely before putting it back into service.
7. Be careful any contaminated material does not contact other areas of the unit or building. Properly dispose of all contaminated materials and cleaning solution.

Bearing Set Screw Alignment

Align bearing set screws for belt-drive fans. See Table 2, p. 56 for set screw torque measurements.

Figure 94. Alignment

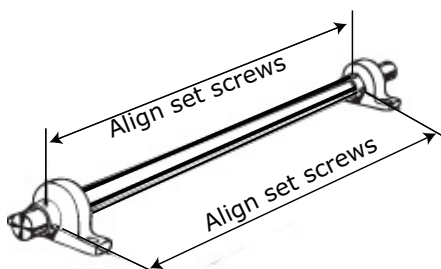

Torque Requirements

Refer to Table 8 for minimum torque of motor mounting and bearings bolts. Refer to Table 2, p. 56 for minimum setscrew torque.

Table 8. Minimum hex head bolt torque in lb.-ft. (Grade 5 bolts)

Size (inches)	Thread Designation	Minimum Torque
1/4-20	UNC	6
1/4-28	UNF	7
65/16-18	UNC	14
5/16-24	UNF	16
3/8-16	UNC	24
3/8-24	UNF	28
7/16-14	UNC	42
7/16-20	UNF	45
1/2-13	UNC	69
1/2-20	UNF	83
9/16-12	UNC	99
9/16-18	UNF	118
5/8-11	UNC	150
5/8-18	UNF	176
3/4-10	UNC	254
3/4-16	UNF	301
7/8-9	UNC	358
7/8-14	UNF	422
1-8	UNC	500
1-14	UNF	602

Note: Soft metric conversions are not acceptable for screw and hex sizes.

Fan Bearing Lubrication

NOTICE

Bearing Failure!

Do not mix greases with different bases within the bearing as it could result in premature bearing failure.

For belt-drive fans, the grease used in electric motor bearings is usually not compatible with the grease used in fan bearings. Never mix the two grease types! See Table 9 for compatible greases and Table 10 for maximum grease capacity.

Note: Lubricate the motor bearing according to the motor manufacturer's recommendations and use the manufacturer-recommended grease. See the "Motor Bearing Lubrication" section on page 78.

Table 9. Compatible greases

Type
Texaco Multi Fak 2
Shell Alvania 2
Mobil 532
Chevron Dura-Lith 2
Exxon Beacon
Keystone 84H

Table 10. Fan bearing maximum grease capacity

Shaft size (inches)	Capacity (fluid ounce)
1/2 - 3/4	1/7
7/8 - 1 3/16	3/8
1 1/4 - 1 1/2	5/8



Routine Maintenance

1 11/16 - 1 15/16	7/8
2 - 2 7/16	1 1/4
2 1/2 - 2 15/16	2

- Fan bearings without lubrication lines are sealed bearings. Re-lubrication is not required.
- Fan bearings equipped with lubrication lines should be lubricated with a lithium-based grease that conforms to NLGI No. 2 for consistency.

Motor Bearing Lubrication

Obtain an operation and maintenance manual from the motor manufacturer for the specific motor installed. The motor manufacturer's recommendations take precedence for all matters related to the start-up and routine maintenance of the motor.

Motor grease fittings have been removed from factory-installed motors in compliance with UL regulations. Motor bearings require periodic maintenance throughout their life. Many different styles of motors come as standard selections, so please obtain the motor IOM and use the manufacturer-recommended grease.

Fan Motor Inspection

Inspect fan motors periodically for excessive vibration or temperature. Operating conditions will vary the frequency of inspection and lubrication. Motor lubrication instructions are on the motor tag or nameplate. If for some reason these instructions are not available, contact the motor manufacturer. Some motor manufacturers may not provide oil tubes on motors with permanently sealed bearings.

Filters

⚠ WARNING

Rotating Components!

Failure to disconnect power before servicing could result in rotating components cutting and slashing technician which could result in death or serious injury. Disconnect all electric power, including remote disconnects before servicing. Follow proper lockout/tagout procedures to ensure the power can not be inadvertently energized.

Note: *Dirty filters will increase static pressure. The increase may effect operation of p-trap drain lines.*

Throwaway Filters

To replace throwaway filters, install new filters with the directional arrows pointing in the direction of airflow.

Bag and cartridge filters must have an airtight seal to prevent air bypass. If using other than Trane-supplied filters, apply foam gasketing to the vertical edges of the filter.

Permanent Filters

To clean permanent filters:

1. Disconnect all electrical power to the unit.
2. Wash the filter under a stream of water to remove dirt and lint.
3. Remove oil from the filter with a wash of mild alkali solution.
4. Rinse the filter in clean, hot water and allow to dry.
5. Coat both sides of the filter by immersing or spraying it with Air Maze Filter Kote W or an equivalent.
6. Allow to drain and dry for about 12 hours.
7. Reinstall the filter.

Note: *It may be preferable to keep extra, clean filters to replace the dirty filters to minimize unit downtime for filter maintenance.*

Front Load Filters

Most filters in custom units are installed in unitary sheet metal frames. Filters are secured with a metal clip. There are several different styles.

To install filters:

1. Disconnect power to the unit.
2. Open or remove the filter clip.
3. Remove the filter from the rack.
4. Install new filters with the directional arrows pointing in the direction of airflow.
5. Secure the filter using the appropriate clip for each filter.

The filters are often installed in a pre/post filter configuration. Be sure to note the order of installation.

Note: *Filters must have an airtight seal to prevent air bypass.*

Side Load Filters

Most filters in custom units are installed in unitary sheet metal frames. If unit is provided with side access rack, do the following for installation:

2-inch or 4-inch Flat Side-Load Filters

1. Disconnect the power to the unit.
2. Open the filter section access door and remove the filters and block-offs from their installed position.
3. Slide the filter into the rack.
4. Some side load racks will be provided with block-off plates. Install them into the rack last before closing the door.
5. Close and secure the door, making certain the door closes snug against the block-off.

Cartridge or Bag Side-Load Filters

To replace cartridge or bag filters:

1. Disconnect all electrical power to the unit.
2. Remove the dirty filters and block-offs from their installed position.
3. Keeping the new bag filters folded, slide each filter into the filter rack, pushing them tightly against the unit.

Note: *The pleats on bag filters should be in the vertical position.*

4. If using the optional pre-filters, replace them on the appropriate filter rack.
5. If fixed and adjustable block-offs are provided with the unit, slide the fixed block-offs into the filter track before the adjustable block-off.

Note: *The adjustable block-off should always be installed last, next to the access door.*

6. Close and secure the access door. If the door can be closed without compressing the filter, adjust the block-off by loosening its screws and position it to provide an airtight seal.

Ultraviolet (UV) Light Maintenance

The intensity of the ultraviolet energy emitted from the ultraviolet bulbs is dependent on the cleanliness and age of the bulb. The surface of the bulb should be kept as clean as possible for optimum intensity. Depending on the filtration level of the HVAC system and the general hygiene of the building, periodic cleaning may be necessary. Before attempting any maintenance procedures, always follow all warnings and cautions as detailed in this maintenance section.

⚠ WARNING

Hazardous Voltage and Exposure to Ultraviolet Radiation!

This product contains components that emit high-intensity ultraviolet (UV-C) radiation which can be harmful to unprotected eyes and skin, and cause serious damage to the equipment.

Failure to disconnect power before servicing could result in burns or electrocution which could result in death or serious injury.

Disconnect all electrical power, including remote disconnects, and make sure the UV lights are off before servicing. Follow proper lockout/tagout procedures to ensure the power cannot be inadvertently energized.

Trane does not recommend field installation of ultraviolet lights in its equipment for the intended purpose of improving indoor air quality. Trane accepts no responsibility for the performance or operation of our equipment in which ultraviolet devices were installed outside of the Trane factory or its approved suppliers.

⚠ WARNING

Hazardous Mercury Vapors!

If large numbers of UV bulbs are broken, an appropriate respirator, as described in OSHA 1910.134, MUST be worn to prevent inhalation of mercury vapors. Mercury vapors are toxic and inhaling them could result in poisoning and suffocation. Failure to follow this recommendation could result in death or serious injury.

Cleaning the Bulbs

Note: *If bulbs are found to be broken, see the proper warning and cautions below regarding broken bulbs and hazardous vapors.*

1. Disconnect all electrical power to the unit and the ultraviolet bulbs.
2. Wearing soft cloth gloves and safety glasses, use two hands and firmly grasp the bulb at each end.
3. Rotate the bulb 90 degrees in either direction and move bulb away from the fixture and out of unit.
4. Wipe down each bulb with a clean cloth and alcohol. Avoid touching the bulb with bare hands as skin oils can



Routine Maintenance

accelerate future glass soiling and degrade the bulb performance.

5. Wearing soft cloth gloves and safety glasses, install lamp by grasping each non-glass end with the thumb and index fingers. Carefully push lamp ends into previously mounted lamp clamps.
6. Attach the loom to the lamp by firmly pushing the four-port connector onto the four pins on the lamp end.

Note: *Connection must be snug to avoid potential arcing.*

Replacing the Bulbs

Ultraviolet bulbs should be replaced annually if operated continuously or after 9,000 hours of use if operated intermittently. Replacement bulbs must be the specific size and wattage as originally supplied from the factory.

Note: *Although the lights may continue to generate a characteristic blue glow beyond 9,000 operating hours, the ultraviolet radiation emitted by the bulbs degrades over time and will no longer provide the intended benefit.*

1. Disconnect power to the HVAC unit and the ultraviolet bulbs. SEE WARNING ABOVE.
2. Before installation, lamps should be cleaned using 99 percent isopropyl alcohol and a lint free cloth.

Note: *Note: If Teflon coated 'EncapsuLamp™' is used, it is not necessary to clean the surface.*

3. Wearing soft cloth gloves and safety glasses, install lamp by grasping each non-glass end with the thumb and index fingers. Carefully push lamp ends into previously mounted lamp clamps.
4. Attach the loom to the lamp by firmly pushing the four-port connector onto the four pins on the lamp end.

Note: *Connection must be snug to avoid potential arcing.*

5. If broken bulbs are found or if you are required to dispose of used bulbs, the proper warning and cautions must be followed.

CAUTION

Broken Glass!

Failure to handle bulbs properly could result in minor to moderate injury. Bulbs are fragile and can be easily broken. To avoid getting cut, always use cloth gloves and eye protection when handling, cleaning or replacing these bulbs. Bulbs may break if dropped or handled improperly. Refer to the MSDS sheet from the bulb manufacturer for additional safety information.

Disposal of Bulbs

UV bulbs, like fluorescent bulbs, contain mercury, which is a regulated hazardous waste. The disposal requirements for hazardous wastes are determined by local, state and federal guidelines. Check all regulations before disposing of bulbs to assure you have met all requirements.

Refer to the MSDS sheet from the bulb manufacturer for additional disposal, handling and safety information.

After replacing bulbs, close and latch all unit panels and reenergize power to the lights.



Troubleshooting

This section is intended to be used as a diagnostic aid only. For detailed repair procedures, contact your local Trane service representative.

⚠ WARNING

Hazardous Service Procedures!

Failure to follow all precautions in this manual and on the tags, stickers, and labels could result in death or serious injury.

Technicians, in order to protect themselves from potential electrical, mechanical, and chemical hazards, **MUST** follow precautions in this manual and on the tags, stickers, and labels, as well as the following instructions: Unless specified otherwise, disconnect all electrical power including remote disconnect and discharge all energy storing devices such as capacitors before servicing. Follow proper lockout/ tagout procedures to ensure the power can not be inadvertently energized. When necessary to work with live electrical components, have a qualified licensed electrician or other individual who has been trained in handling live electrical components perform these tasks.

Table 11. Air handler troubleshooting recommendations

Symptom	Probable Cause	Recommended Action
Bearing is excessively hot	First start after relubrication (Grease distribution)	Allow machine to cool down and restart.
	Over-lubrication	Clean surface of grease and purge.
	Over tensioned belts	Adjust belt tension.
	No lubricant	Apply lubricant. Check bearings for damage.
Motor fails to start	Misaligned bearing	Correct alignment. Check shaft level.
	Blown fuse or open circuit breaker	Replace fuse or reset circuit breaker.
	Overload trip	Check and reset overload.
	Improper wiring or connections	Check wiring with diagram supplied on unit.
Motor stalls	Improper current supply	Compare actual supply power with motor nameplate recommendations. Contact power company for adjustments.
	Mechanical failure	Check that motor and drive rotate freely. Check bearing lubricant.
	Open phase	Check line for an open phase.
	Overloaded motor	Reduce load or replace with larger motor.
Excessive vibration	Low line voltage	Check across AC line. Correct voltage if possible.
	Poor alignment	Align bearing set screws (see Table 3, p. 57). Loosen and retighten bearing set screws.
	Shipping spacers not removed	Remove shipping spacers and/or bolts (see "Fan Isolation," p. 30).
	Over tensioned belts	Adjust belt tension.
Motor runs and then dies down	Misaligned drive	Align drive.
	Partial loss of line voltage	Check for loose connections. Determine adequacy of main power supply.
	Starter shorts when motor warms up	Replace starter.
	Motor does not come up to speed	Check across AC line and correct voltage loss if possible.
Motor overheats	Line wiring to motor too small	Replace with larger sized wiring.
	Overloaded motor	Reduce load or replace with a larger motor.
	Motor fan is clogged with dirt preventing proper ventilation	Remove fan cover, clean fan and replace cover.
	Excessive motor noise	Motor mounting bolts loose
Rigid coupling connections		Replace with flexible connections.
Worn motor bearings		Replace bearings and seals.
Fan rubbing on fan cover		Remove interference in motor fan housing.
Rapid motor bearing wear	Excessive overhung load due to overtensioned drive	Check belt tension and overhung load.
	Excessive overhung load due to a small diameter motor sheave	Replace sheave with larger one.
Loose fan belt	Motor is poorly positioned	Adjust belt tension.
	Worn or damaged belt	Replace belt or belt set. Check sheave alignment.
	Worn sheaves	Replace sheaves.
Short belt life	Worn sheaves	Replace sheaves.
	Misaligned belt	Realign drive with MVP sheave set at mean pitch diameter.
	Grease or oil on belts	Check for leaky bearings. Clean belts and sheaves.
	Belt slipping	Improper belt tension. Adjust tension.
	Belts rubbing	Remove obstruction or realign drive for clearance.

Troubleshooting

Table 11. Air handler troubleshooting recommendations (continued)

Symptom	Probable Cause	Recommended Action
Bearing noise	Poor alignment	Loosen bearing set screws and realign (see "Align Fan and Motor Sheaves," p. 57)
	Failed bearing	Replace bearing.
	Inadequate lubrication	Replace bearing.
Low water coil capacity	Incorrect airflow	Check fan operating condition.
	Incorrect water flow	Inspect the water pumps and valves for proper operation and check the lines for obstructions.
	Incorrect water temperature	Adjust the chiller or boiler to provide the proper water temperature.
	Coil is piped incorrectly	Verify coil piping (see "Piping and Connections," p. 37).
	Dirty fin surface	Clean the fin surface (see "Coils" on page 64).
Incorrect glycol mixture	Verify glycol mixture and adjust if necessary.	
Low refrigerant coil capacity	Incorrect airflow	Check fan operating condition.
	Expansion valve is not operating properly or is sized incorrectly	Check sensing bulb temperature. Verify valve operation. Verify proper valve size.
	Incorrect refrigerant charge	Verify refrigerant charge and adjust if necessary.
	Condensing unit failure	Verify condensing unit operation.
	Coil is piped incorrectly	Verify coil piping (see "Piping and Connections," p. 37.)
	Clogged refrigerant line filter	Change filter core.
	Failure of suction/liquid line components	Verify component operation
	Dirty fin surface	Clean the fin surface (see "Coils," p. 64). Do not use steam to clean refrigerant coils.
Fin frosting	Verify defrost cycle operation. Verify frostat operation. Verify refrigerant charge.	
Low steam coil capacity	Incorrect airflow	Check fan operating condition.
	Coil is piped incorrectly	Verify coil piping (see "Piping and Connections," p. 37).
	Incorrect steam pressure	Verify steam pressure and adjust if necessary.
	Excessive steam superheat	Check steam superheat. Steam superheat should not exceed 50°F.
	Failure of steam line/condensate return components	Verify component operation
	Boiler failure	Verify boiler operation
Dirty fin surface	Clean the fin surface (see "Coils," p. 64).	
Drain pan is overflowing	Plugged Drain Line	Clean drain line
	Unit not level	Level unit
	Improper trap design	Design trap per unit installation instructions
Standing water in drain pan	Improper trap design	Design trap per unit installation instructions
	Unit not level	Level unit
	Plugged drain line	Clean drain line
Wet interior	Coil face velocity too high	Reduce fan speed
	Improper trap design	Design trap per unit installation instructions
	Drain pan leaks/overflows	Repair leaks
	Condensation on surfaces	Insulate surfaces
Excess dirt in unit	Missing filters	Replace filters
	Filter bypass	Reduce filter bypass by ensuring all blockoffs are in place.
Microbial growth (mold) inside air handler	Standing water in drain pan	See "Standing water in drain pan" above

Table 11. Air handler troubleshooting recommendations (continued)

Symptom	Probable Cause	Recommended Action
Energy wheel will not rotate	Motor is not running	The fuse or circuit breaker may be blown or open. Check the breaker/fuse box and replace.
		There may be a loss of incoming power. Attempt to trace the power loss back to its source and correct.
		The motor may have failed. Check for power at the motor terminals. If present, disconnect the belt from the motor pulley and see if the motor runs without a load. If it still doesn't run, replace the motor.
		The motor may have failed because it is connected to a variable frequency drive. Disconnect the VFD and run the motor on 60 Hz power only.
	Excessive friction at the seals	Re-adjust the diameter seals. See "Energy Wheel Seal Adjustment," p. 76.
	Energy wheel frame or spokes are bent or warped	Inspect the wheel, locate the bent section, and straighten the section or replace the frame.
Loss of energy wheel capacity	During winter operation, excessive frost/ice forms in the heat transfer media	Disconnect power to the wheel motor, adjust outside air dampers shut and let the wheel thaw. After the initial section thaws, rotate the wheel 90 degrees by hand until the "new" section rotates into the warm exhaust air stream. Continue this procedure until the wheel is completely thawed.
	Drive belt is broken	Inspect visually. Replace the drive belt.
	Wheel main shaft bearing is seized	Replace the seized bearing.
	Wheel is not rotating	See above
	Wheel is rotating too slowly	Belt is stretched, slipping. Replace the belt.
		Ice forms on the wheel; thaw per above.
Seized bearing on the main shaft; replace the bearing.		
Excessive friction in seals; adjust.		
Energy transfer surface is contaminated	Clean the energy transfer surfaces. Consider purchasing a second set of energy transfer segments for continuous operation while cleaning. Replace the energy transfer segments if they are severely contaminated and cannot be cleaned. Consider adding a contaminate filter before (upstream) the energy wheel.	
Frost/ice forms on heat transfer surfaces	Thaw the wheel surfaces per procedure above. Consider adding outside air preheat.	
Worn diameter seals in energy wheel	Maximum wheel pressure drop exceeded	Adjust wheel airflow so that the pressure drop across the wheel is less than 1.25 inches wg.
	Seal adjusted too tight	Adjust seals. See "Energy Wheel Seal Adjustment," p. 76.
UV light fails	Ballast fails to energize light.	Disconnect high voltage leads (green, white, and black connectors) from the ballast enclosure. Wait for three minutes, this will reset the end-of-light circuitry and then reconnect.
	End of life.	Replace bulb. See "Replacing the Bulbs," p. 80.

Trane - by Trane Technologies (NYSE: TT), a global climate innovator - creates comfortable, energy efficient indoor environments for commercial and residential applications. For more information, please visit trane.com or tranetechnologies.com.

Trane has a policy of continuous product and product data improvement and reserves the right to change design and specifications without notice. We are committed to using environmentally conscious print practices.