



Installation, Operation, and Maintenance

Trane Rental Services

Temporary Cooling - Flexible Water Hose



⚠ SAFETY WARNING

Only qualified personnel should install and service the equipment. The installation, starting up, and servicing of heating, ventilating, and air-conditioning equipment can be hazardous and requires specific knowledge and training. Improperly installed, adjusted or altered equipment by an unqualified person could result in death or serious injury. When working on the equipment, observe all precautions in the literature and on the tags, stickers, and labels that are attached to the equipment.



Introduction

Read this manual thoroughly before operating or servicing this unit.

Warnings, Cautions, and Notices

Safety advisories appear throughout this manual as required. Your personal safety and the proper operation of this machine depend upon the strict observance of these precautions.

The three types of advisories are defined as follows:

- ⚠ WARNING** Indicates a potentially hazardous situation which, if not avoided, could result in death or serious injury.
- ⚠ CAUTION** Indicates a potentially hazardous situation which, if not avoided, could result in minor or moderate injury. It could also be used to alert against unsafe practices.
- NOTICE** Indicates a situation that could result in equipment or property-damage only accidents.

Important Environmental Concerns

Scientific research has shown that certain man-made chemicals can affect the earth's naturally occurring stratospheric ozone layer when released to the atmosphere. In particular, several of the identified chemicals that may affect the ozone layer are refrigerants that contain Chlorine, Fluorine and Carbon (CFCs) and those containing Hydrogen, Chlorine, Fluorine and Carbon (HCFCs). Not all refrigerants containing these compounds have the same potential impact to the environment. Trane advocates the responsible handling of all refrigerants.

Important Responsible Refrigerant Practices

Trane believes that responsible refrigerant practices are important to the environment, our customers, and the air conditioning industry. All technicians who handle refrigerants must be certified according to local rules. For the USA, the Federal Clean Air Act (Section 608) sets forth the requirements for handling, reclaiming, recovering and recycling of certain refrigerants and the equipment that is used in these service procedures. In addition, some states or municipalities may have additional requirements that must also be adhered to for responsible management of refrigerants. Know the applicable laws and follow them.

⚠ WARNING

Proper Field Wiring and Grounding Required!

Failure to follow code could result in death or serious injury. All field wiring **MUST** be performed by qualified personnel. Improperly installed and grounded field wiring poses **FIRE** and **ELECTROCUTION** hazards. To avoid these hazards, you **MUST** follow requirements for field wiring installation and grounding as described in **NEC** and your local/state/national electrical codes.

⚠ WARNING

Personal Protective Equipment (PPE) Required!

Failure to wear proper PPE for the job being undertaken could result in death or serious injury. Technicians, in order to protect themselves from potential electrical, mechanical, and chemical hazards, **MUST** follow precautions in this manual and on the tags, stickers, and labels, as well as the instructions below:

- Before installing/servicing this unit, technicians **MUST** put on all PPE required for the work being undertaken (Examples; cut resistant gloves/sleeves, butyl gloves, safety glasses, hard hat/bump cap, fall protection, electrical PPE and arc flash clothing). **ALWAYS** refer to appropriate Safety Data Sheets (SDS) and OSHA guidelines for proper PPE.
- When working with or around hazardous chemicals, **ALWAYS** refer to the appropriate SDS and OSHA/GHS (Global Harmonized System of Classification and Labeling of Chemicals) guidelines for information on allowable personal exposure levels, proper respiratory protection and handling instructions.
- If there is a risk of energized electrical contact, arc, or flash, technicians **MUST** put on all PPE in accordance with OSHA, NFPA 70E, or other country-specific requirements for arc flash protection, **PRIOR** to servicing the unit. **NEVER PERFORM ANY SWITCHING, DISCONNECTING, OR VOLTAGE TESTING WITHOUT PROPER ELECTRICAL PPE AND ARC FLASH CLOTHING. ENSURE ELECTRICAL METERS AND EQUIPMENT ARE PROPERLY RATED FOR INTENDED VOLTAGE.**

⚠ WARNING**Follow EHS Policies!**

Failure to follow instructions below could result in death or serious injury.

- **All Trane personnel must follow the company's Environmental, Health and Safety (EHS) policies when performing work such as hot work, electrical, fall protection, lockout/tagout, refrigerant handling, etc. Where local regulations are more stringent than these policies, those regulations supersede these policies.**
- **Non-Trane personnel should always follow local regulations.**

Copyright

This document and the information in it are the property of Trane, and may not be used or reproduced in whole or in part without written permission. Trane reserves the right to revise this publication at any time, and to make changes to its content without obligation to notify any person of such revision or change.

Trademarks

All trademarks referenced in this document are the trademarks of their respective owners.

Revision History

- Updated Component Specification section in General Information chapter.
- Revised hose kit contents in Unit Dimensions and Weights chapter.
- Added individual component weights in Unit Dimensions and Weights chapter.
- Updated Horizontal Hose Installation, Vertical Hose Installation, Horizontal to Vertical Installation sections, and hose installation figures in Installation chapter.



Table of Contents

Model Number Description	5
Water Hose Box	5
General Information	6
Overview	6
Exceptions	6
Component Specification	6
All Hose Sizes	6
Unit Dimensions and Weights	7
Pressure Loss of Flex Hose	8
Installation	10
Victaulic Coupling Installation	10
Tools Required	10
Coupling Installation Procedure	11
Proper Hose Installation Guidelines	14
Flexible Hose used in Suction-Side Piping	14
Horizontal Hose Installation	14
Vertical Hose Installation	14
Horizontal to Vertical Installation	15
Material Disposition	15
Hard Pipe Installation	15



Model Number Description

Water Hose Box

Digit 1, 2 — Rental Services

CS

Digit 3, 4 — Water Hose

CH

Digit 5, 6, 7 — Total Linear Feet and Diameter Hose

1** = Hose - 100 Total Linear Feet

0** = Hose - 200 Total Linear Feet

*02 = Hose - 2.5-inch Diameter

*04 = Hose - 4-inch Diameter

*06 = Hose - 6-inch Diameter

*10 = Hose - 10-inch Diameter

Digit 9, 10, 11— Unique Asset Identifier for Rental Services

A

B

A



General Information

Overview

This IOM covers the flexible water hose available to rent for temporary cooling solutions, including box contents, technical information on each component, and proper flexible water hose installation.

Trane Rental Services offers several sizes of flexible water hose to rent for customers who have temporary cooling needs. The hose is proof tested to 150 psig. Trane provides a system of Victaulic® couplings, fittings, and various lengths of hose to provide consistent, rapid deployment of water chillers for temporary applications. The flexible water hose is intended for outdoor, horizontal runs connecting the inlet and outlet of the chiller and pumps to the existing chilled water system. Contact Trane Rental Services 24/7 with specific questions.

Exceptions

Any exceptions to the guidelines established in this document must be authorized in writing by Trane Rental Services.

Component Specification

All Hose Sizes

Hose Material

- Premium quality, through-the-weave extruded potable water transport hose
- Rated NSF61 for transport of potable water
- Exterior jacket is polyurethane
- Rated for -36°F to 122°F working temperature range
- Maximum safe working pressure is 150 psig
- Ozone resistant

Hose End Fittings

Victaulic® type couplings of anodized aluminum

Couplings

- Victaulic couplings may be Style 07 Zero-Flex®, Style 107H, 107N, and 107V QuickVic®. See "Installation," p. 10 for further details.
- Grooved pipe couplings designed to join with plastic or steel pipe prepared to Victaulic groove specifications.

- Couplings can be joined with other Victaulic grooved end fittings, valves, and related grooved end components.
- They are not intended for use with plain end pipe and/or fittings.

Coupling Gaskets

- For proper assembly, use a lubricated Victaulic gasket when joining parts. Trane Rental Services gaskets are EPDM (material).
- Do not use hydrocarbon-based lubricants to avoid degrading gasket material. See Table 1, p. 6.

Notes:

- Gaskets for style 107H, 107N, and 107V couplings should remain inside the metal housing during installation. See "Installation," p. 10 section for details.
- Silicone based lubricant should be used.
- The following recommendations are for the gasket materials listed. Refer to the manufacturer's recommendations for material compatibility.

Fittings

- Each box is equipped with painted Ductile Iron Victaulic to Victaulic fittings in both 90° and 45° styles.
- Fittings are compatible with standard HVAC fluids (ethylene and propylene glycol mixtures, calcium chloride and typical scale and corrosion inhibitors).

Miscellaneous

Limited quantities of other style fittings, reducers, and non-standard size couplings are available upon request from Trane Rental Services.

Vic-Flange® Adapters

- Each box comes with two Victaulic to Flange adapters and gaskets.
- Adapters are designed to join to ANSI Class 125 or 150 flange bolt patterns.
The gasket provided will seal on both the vertical flange face and horizontal pipe surface when installed properly. The gasket profile is a C.

Flange Bolts and Nuts

The hex cap bolts and nuts provided are grade 5 zinc plated.

Table 1. Lubricant compatibility for gaskets

	Victaulic Lubricant	Soap-Based Solutions	Glycerin	Silicone Grease	Silicone Spray	Corn Oil	Soybean Oil	Hydrocarbon-Based Oils	Petroleum-Based Greases
Compatible with EPDM Gaskets?	Yes	Yes	Yes	Yes	Not Recommended	Not Recommended	Not Recommended	Not Recommended	Not Recommended



Unit Dimensions and Weights

⚠ WARNING

Heavy Objects!

Failure to properly lift unit could result in death or serious injury or possible equipment or property-only damage. Use a forklift of suitable capacity to move the unit.

Table 2. Approximate weights and dimensions for hose kits

Hose Size (in)	Total Liner Feet of Hose in Each Kit	Weight of Box (lbs)	Length	Width	Height
2.5	100	300	4 ft 1-inch	4 ft	2 ft 10-inch
2.5	200	330			
4	100	410			
4	200	470			
6	100	650	4 ft 9-inch	3 ft 11-inch	4 ft 4-inch
6	200	900			
10	200	2150	7 ft 11-inch	3 ft 11-inch	4 ft 4-inch

- Each box is labeled with a placard or stencil with a unique inventory number (including the hose size).
- Contents are displayed on the inside of the box.
- Each box is designed for easy shipping and handling to be moved with a fork or pallet truck.
- Painted steel boxes with a hinged lid may be used instead of the plastic box.
- Contents can be unloaded from the front of larger, aluminum boxes.
- To avoid potential charges for missing parts when returned, each box should be inspected upon receipt. If parts are missing, notify Trane Rental Services immediately.

Table 3. Hose kit contents

Hose Kit Type	Component Description	Component Weight (lbs)	Quantity per Kit
2.5-Inch, 100 ft Kit	90° Elbows	3.2	4
	45° Elbows	2.2	4
	Victaulic to Flange Adapters	4.8	2
	Victaulic Couplings	3.0	18
	5/8-inch x 2 1/4-inch Bolts and Nuts	0.1	8
	10 ft Hose Section	7.0	2
	15 ft Hose Section	9.5	2
	25 ft Hose Section	14.0	2
	Plastic Hose Box	140.0	1
Vacuum Formed Box Lid	27.0	1	

Table 3. Hose kit contents (continued)

Hose Kit Type	Component Description	Component Weight (lbs)	Quantity per Kit
2.5-Inch, 200 ft Kit	90° Elbows	3.2	2
	45° Elbows	2.2	2
	Victaulic to Flange Adapters	4.8	2
	Victaulic Couplings	3.0	16
	5/8-inch x 2 1/4-inch Bolts and Nuts	0.1	8
	10 ft Hose Section	7.0	1
	15 ft Hose Section	9.5	1
	25 ft Hose Section	14.0	1
	50 ft Hose Section	25.0	3
Plastic Hose Box	140.0	1	
Vacuum Formed Box Lid	27.0	1	
4-Inch, 100 ft Kit	90° Elbows	7.1	4
	45° Elbows	5.6	4
	Victaulic to Flange Adapters	7.4	2
	Victaulic Couplings	5.1	18
	5/8-inch x 2 1/2-inch Bolts and Nuts	0.1	8
	10 ft Hose Section	15.3	2
	15 ft Hose Section	20.35	2
	25 ft Hose Section	30.45	2
	Plastic Hose Box	140.0	1
Vacuum Formed Box Lid	27.0	1	
4-Inch, 200 ft Kit	90° Elbows	7.1	2
	45° Elbows	5.6	2
	Victaulic to Flange Adapters	7.4	2
	Victaulic Couplings	5.1	16
	5/8-inch x 2 1/2-inch Bolts and Nuts	0.1	16
	10 ft Hose Section	15.3	1
	15 ft Hose Section	20.35	1
	25 ft Hose Section	30.45	1
	50 ft Hose Section	55.7	3
Plastic Hose Box	140.0	1	
Vacuum Formed Box Lid	27.0	1	
6-Inch, 100 ft Kit	90° Elbows	17.2	4
	45° Elbows	10.8	4
	Victaulic to Flange Adapters	9.9	2
	Victaulic Couplings	8.2	18
	3/4-inch x 3-inch Bolts and Nuts	0.1	16
	10 ft Hose Section	31.9	2
	15 ft Hose Section	40.0	2
	25 ft Hose Section	56.0	2
	Plastic Hose Box	140.0	1
Vacuum Formed Box Lid	27.0	1	



Unit Dimensions and Weights

Table 3. Hose kit contents (continued)

Hose Kit Type	Component Description	Component Weight (lbs)	Quantity per Kit
6-Inch, 200 ft Kit	90° Elbows	17.2	2
	45° Elbows	10.8	2
	Victaulic to Flange Adapters	9.9	2
	Victaulic Couplings	8.2	15
	3/4-inch x 3-inch Bolts and Nuts	0.1	16
	10 ft Hose Section	31.9	1
	15 ft Hose Section	40.0	1
	25 ft Hose Section	56.0	7
	Plastic Hose Box	140.0	1
	Vacuum Formed Box Lid	27.0	1
10-Inch, 200 ft Kit	90° Elbows	63.3	2
	45° Elbows	37.5	2
	Victaulic to Flange Adapters	24.2	2
	Victaulic Couplings	23.6	16
	7/8-inch x 3 1/2-inch Bolts and Nuts	0.2	24
	10 ft Hose Section	66.1	1
	15 ft Hose Section	80.5	1
	25 ft Hose Section	109.2	7
	Aluminum Hose Box	800.0	1

Note: Kit contents subject to change, Trane reserves the right to make substitutions of multiple lengths to make up for longer hose sections.

Pressure Loss of Flex Hose

Chiller nominal, minimum, and maximum flow rates are recorded in CHS-SVN06*-EN.

Table 4. Pressure loss (in psi) per 100 ft of flexible water hose

Flow (GPM)	Hose Diameter			
	2.5-inch	4-inch	6-inch	10-inch
25	0.45	0.02	-	-
50	1.61	0.06	-	-
75	3.42	0.12	-	-
100	5.82	0.21	-	-
150	12.34	0.45	-	-
175	16.42	0.60	-	-
200	21.02	0.76	-	-
225	26.15	0.95	-	-
250	31.78	1.16	-	-
275	37.92	1.38	-	-
300	44.55	1.62	0.25	-
325	51.67	1.88	0.29	-
350	-	2.16	0.33	-
375	-	2.45	0.38	-

Table 4. Pressure loss (in psi) per 100 ft of flexible water hose (continued)

Flow (GPM)	Hose Diameter			
	2.5-inch	4-inch	6-inch	10-inch
400	-	2.76	0.42	-
425	-	3.09	0.47	-
450	-	3.43	0.53	-
500	-	4.17	0.64	-
550	-	4.98	0.76	-
600	-	5.85	0.90	0.08
650	-	6.78	1.04	0.09
700	-	7.78	1.19	0.11
750	-	8.84	1.36	0.12
800	-	9.96	1.53	0.13
900	-	12.39	1.90	0.17
1000	-	15.06	2.31	0.20
1100	-	17.97	2.76	0.24
1200	-	21.11	3.24	0.29
1300	-	24.48	3.76	0.33
1400	-	28.08	4.31	0.38
1500	-	31.91	4.90	0.43
2000	-	54.37	8.35	0.74
2500	-	-	12.62	1.11
3000	-	-	17.68	1.56
3500	-	-	23.53	2.07
4000	-	-	30.13	2.65
5000	-	-	45.54	4.01
5500	-	-	54.34	4.79
6000	-	-	63.84	5.62
6500	-	-	-	6.52
7000	-	-	-	7.48
7500	-	-	-	8.50
8000	-	-	-	9.58
9000	-	-	-	11.92
9500	-	-	-	13.17
10000	-	-	-	14.48
10500	-	-	-	15.85
11000	-	-	-	17.28
11500	-	-	-	18.76
12000	-	-	-	20.30
12500	-	-	-	21.90
13000	-	-	-	23.55
13500	-	-	-	25.25
14000	-	-	-	27.01

Figure 1. Pressure drop vs. flow for Trane rental services hose

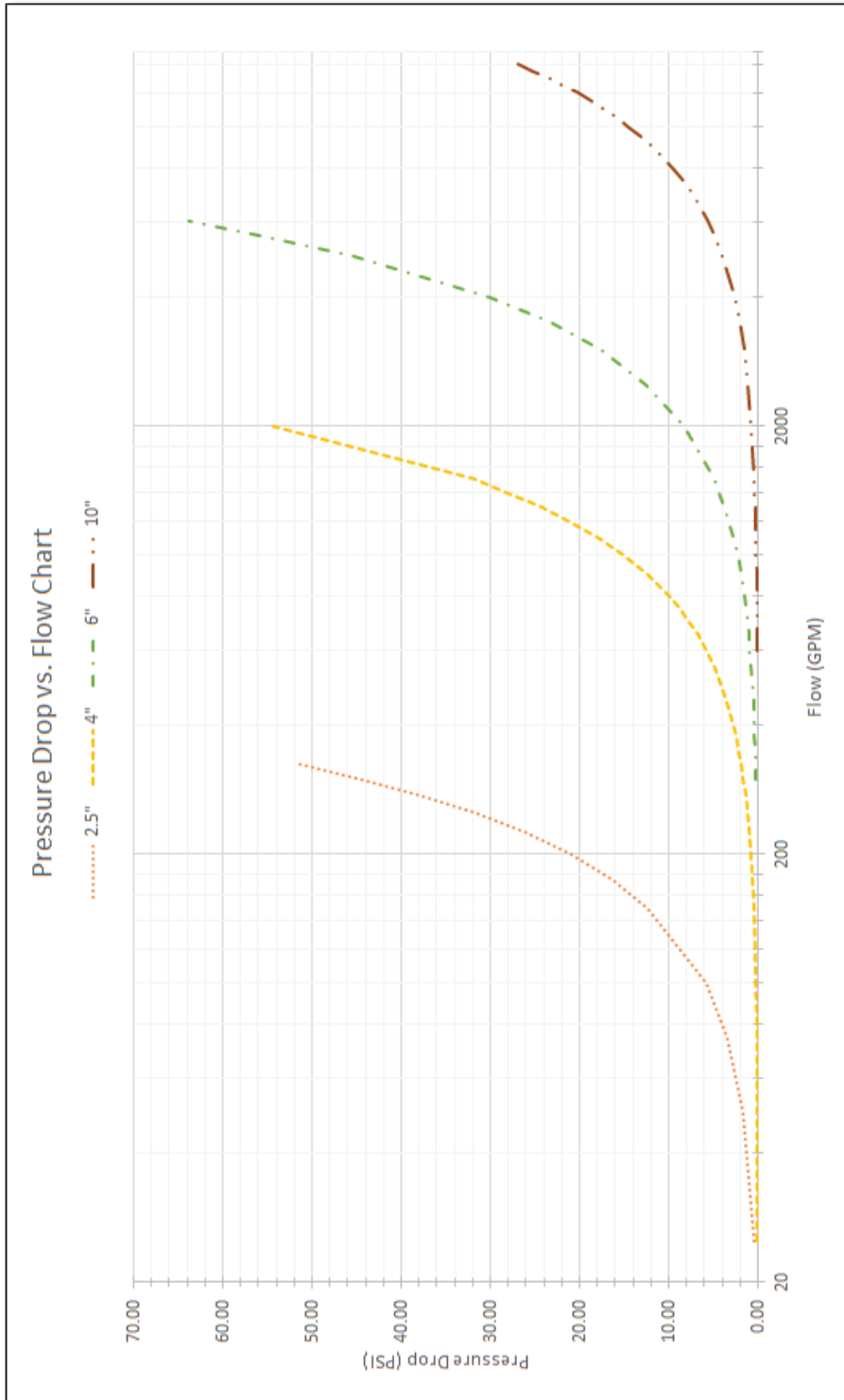



Installation

This section advises Trane service or contractors to the proper installation of flexible hose provided as part of a Trane Rental Services rental project.

Trane disclaims liability for damages and costs resulting from any failure to follow the instructions in this manual.

⚠ WARNING

Hose Failure!

Failure to comply with installation instructions that follow could result in death or serious injury or equipment damage.

NOTICE

Water Damage!

Flexible hose can burst. Flexible hose should never be used for an indoor installation. Failure to follow this recommendation could lead to equipment or property-only-damage.

NOTICE

Hose Damage!

Failure to follow instructions may lead to hose damage. Hose must never be pressurized over 150 psi. If higher pressures are required, "hard" suction pipe must be utilized.

NOTICE

Hose Damage!

Failure to follow instructions may lead to hose collapse and total system failure. Hose must always be used in pressurized application. If a negative pressure application is required, "hard" suction pipe must be used.

NOTICE

- **Hard pipe is recommended for indoor installations. Flexible hose can burst. Failure to follow this could lead to equipment or property damage.**
- **Do not support the hose ONLY by its couplings, support over half of the hose's length by ground or other supporting surface otherwise coupling clamps may fail.**
- **Do not run hose vertically more than 7 feet coupling clamps may fail.**
- **Do not cut hose to custom fit pieces. This will affect the integrity of the hose.**
- **Bleed all air from the system prior to pressurizing hose to avoid couplings separating from the hose.**
- **Install elbows for a smooth hose transition on all vertical hose installations, see [Figure 4, p. 14](#).**
- **Never pressurize hose above 150 psig.**

Victaulic Coupling Installation

Tools Required

Style 07/107H/107N/107V (Zero-Flex or QuickVic)

- Lube for gaskets (non-petroleum)
- Socket wrench or impact driver

Table 5. Maximum allowable bolt torque for 07 and 107 style couplings

Size	Max Torque
2.5-inch	135 ft-lbs
4-inch	135 ft-lbs
6-inch	235 ft-lbs
10-inch	675 ft-lbs

Coupling Installation Procedure

See proper hose installation guidelines section for how to layout the path for the flexible hose.

Style 07 (Zero-Flex) Installation

1. Perform work area inspection and identify proper PPE.
2. Confirm clearances needed for installation.
3. Open coupling and remove gasket.
4. Loosen both bolts, but only completely remove the bolt on one side of the housing, and confirm the ability to rotate the housing open in order to swing it back over the pipe later in the installation.
5. Perform inspection
 - a. Inspect coupling gaskets for tears or worn areas, replace as necessary.
 - b. Inspect coupling for proper mechanical operation (i.e. frozen bolts/nuts).
 - c. Inspect the grooved hose end (or customer pipe if making connection to an existing pipe) for damage, indentations, or projections. Pipe surface must be free of oil, grease, dirt, and cutting particles.

NOTICE

Water or Contaminant Leak!

Failure to properly lubricate and prevent gasket pinching may result in a leak which could result in damage to equipment and property.

6. Lubricate gasket surfaces. See [Table 1, p. 6](#).
7. Place gasket over one pipe end. Confirm it does not overhang.



8. Align and join the other pipe end then slide the gasket to the center of the joint. Confirm the gasket does not extend into the groove on either pipe end.



9. Install the coupling housing.
 - a. Place one half of the housing over/under the pipe and swing the other half over the pipe and into place on the opposite side.
 - b. Squeeze the housing together. Confirm the housing engages the grooves on the pipe ends and center the gasket in the housing.
 - c. Loosely install bolt to secure housing.

Important: Before tightening the bolts, confirm gasket is not pinched in the housing.

10. Tighten bolts.

⚠ CAUTION

Pinch Hazard!

Failure to keep fingers and other body parts clear of the locking mechanism could result in minor to moderate personal injury.

- a. Tighten the bolts by alternating sides to ensure gasket does not become pinched on one side.
- b. When tightening, confirm housing continues to fully seat inside pipe grooves.
- c. Tighten until metal to metal contact is achieved on the angled, metal pads on each side of the housing.

⚠ WARNING

Over Torque!

Do not continue to torque past the visual criteria for a properly secured joint. Continuing to torque past this point may result in gasket or housing damage which may cause the joint to burst apart under pressure, which could result in death or serious personal injury.

Note: There is no minimum torque specification. A proper joint has been achieved once there is metal to metal contact on both sides of the housing. Refer to [Table 5, p. 10](#) for maximum allowable bolt torque for 07 and 107 style couplings.

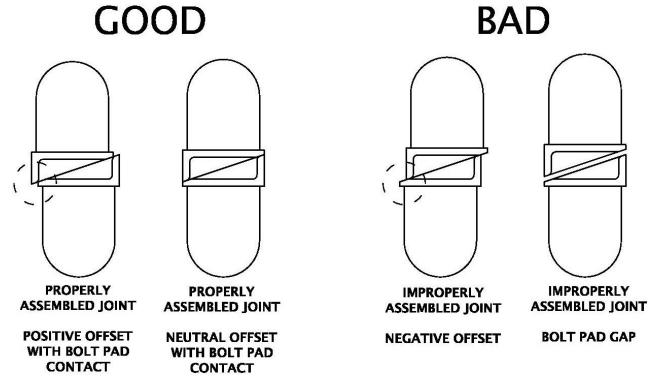

WARNING

Hose Under Pressure!

Failure to properly depressurize flexible hose before servicing could result in the coupling bursting apart, which could result in death or serious injury.

11. Decommission / Reinstall

- a. Open drain valve and release pressure from the hose.
- b. Press on flexible hose to confirm pressure is released.
- c. Use tool to loosen housing bolts.
- d. Remove housing.
- e. Separate pipe ends.
- f. Remove gasket.
- g. Repeat inspections described in [Step 5](#).
- h. Reinstall per [Step 6](#) through [Step 11](#).

Note: If decommissioning, replace the gasket into the housing and install both bolts in the coupling before placing in Rental hose box.

Style 107H/107N/107V (QuickVic) Installation

1. Perform work area inspection and identify proper PPE.
2. Confirm clearances needed for installation.
3. DO NOT remove either bolt, loosen them only.
This coupling is designed to be installed without removing the gasket or the bolts.
4. Perform inspection.
 - a. Inspect coupling gaskets for tears or worn areas, replace as necessary.
 - b. Inspect coupling for proper mechanical operation (i.e. frozen bolts/nuts).
 - c. Inspect the grooved hose end (or customer pipe if making connection to an existing pipe) for damage, indentations or projections. Pipe surface must be free of oil, grease, dirt and cutting particles.

NOTICE

Water or Contaminant Leak!

Failure to properly lubricate and prevent gasket pinching may result in a leak which could result in damage to equipment and property.

5. Lubricate gasket surfaces. See [Table 1, p. 6](#).
6. Push the coupling onto the first pipe end until the pipe makes contact with the middle leg of the gasket. Repeat for the other pipe end.

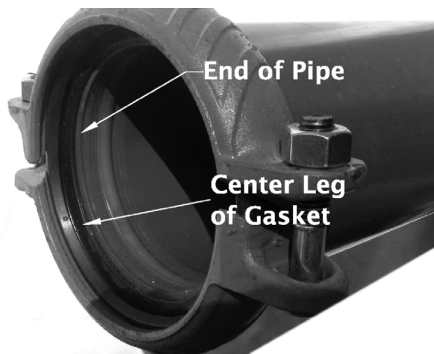

7. When tightening, confirm housing will fully seat into the pipe grooves.
8. Tighten bolts.



CAUTION

Pinch Hazard!

Failure to keep fingers and other body parts clear of the locking mechanism could result in minor to moderate personal injury.

- a. Tighten the bolts by alternating sides to ensure gasket does not become pinched on one side.
- b. When tightening, confirm housing continues to fully seat inside pipe grooves.
- c. Tighten until metal to metal contact is achieved on the angled, metal pads on each side of the housing.

WARNING

Over Torque!

Do not continue to torque past the visual criteria for a properly secured joint. Continuing to torque past this point may result in gasket or housing damage which may cause the joint to burst apart under pressure, which could result in death or serious personal injury.

Note: There is no minimum torque specification. A proper joint has been achieved once there is metal to metal contact on both sides of the housing. Refer to [Table 5, p. 10](#) for maximum allowable bolt torque for 07 and 107 style couplings.

GOOD

BAD

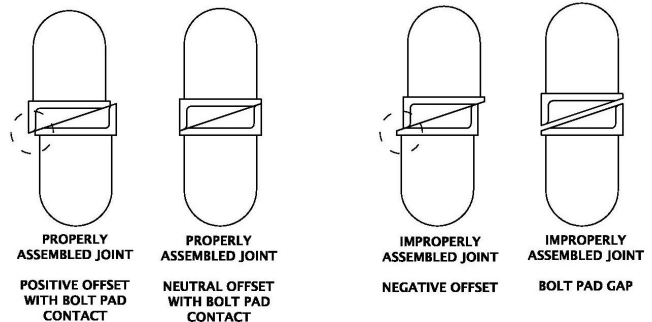

WARNING

Hose Under Pressure!

Failure to properly depressurize flexible hose before servicing could result in the coupling bursting apart, which could result in death or serious injury.

9. Decommission / Reinstall.
 - a. Open drain valve and release pressure from the hose.
 - b. Press on flexible hose to confirm pressure is released.
 - c. Use tool to loosen housing bolts.
 - d. Separate pipe ends to retrieve coupling.

Important: Do not completely remove the bolts from the housing.

- e. Repeat inspections described in [Step 4](#).
- f. Reinstall per [Step 5](#) through [Step 9](#).

Note: If decommissioning, hand tighten the bolts on the coupling (confirm the gasket is still inside) before placing into Rental hose box.

Proper Hose Installation Guidelines

Flexible Hose used in Suction-Side Piping

Flexible hose may collapse if internal pressure is negative (such as on the suction side of a pump).

In an open loop system (such as a cooling tower loop) hard piping (steel/PVC/other) is required on the suction side of pumps.

In a closed loop system, there is usually sufficient back-pressure to prevent the hose from collapsing, but hard piping is still recommended on the suction side of any pumps.

Horizontal Hose Installation

Figure 2. Correct horizontal hose installation

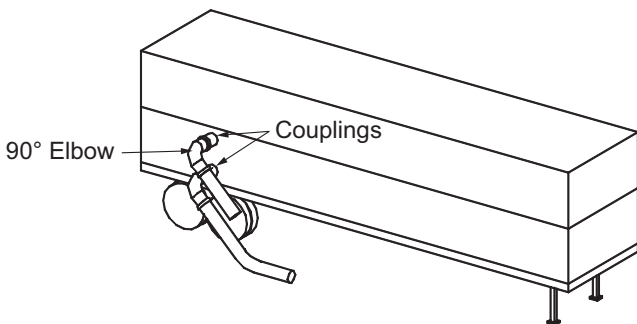

[Figure 2, p. 14](#) shows a **correct** hose installation. In this configuration either a 45° or 90° elbow can be installed. This elbow prevents stretching and crimping of the hose at the hose coupling connection. This elbow also directs the hose to the ground at an appropriate angle to minimize the crimping of the hose at the ground or supporting surfaces.

Figure 3. Incorrect horizontal hose installation

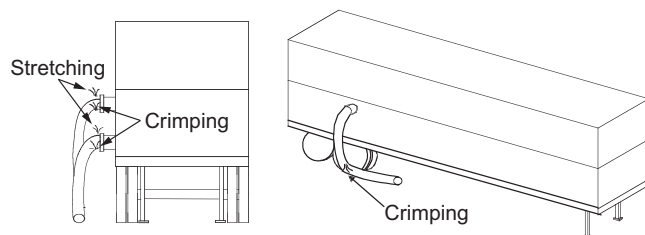

[Figure 3, p. 14](#) shows an **incorrect** hose installation. Elbows are **not** installed. This causes the top of the hose to be in tension, which stretches the hose out of the coupling, and the bottom of the hose to be in compression, which causes it to crimp. It also causes the hose to crimp at the ground.

Vertical Hose Installation

Figure 4. Correct vertical hose installation

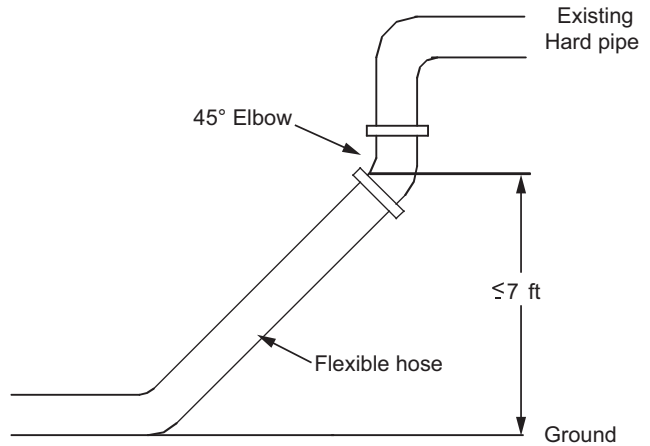

[Figure 4, p. 14](#) shows a **correct** vertical hose installation. In this configuration, the hose is installed with an elevation less than 7 feet off the ground. A 45° elbow is installed to reduce the stress in the hose coupling connection. This elbow also directs the hose to the ground at an appropriate angle to minimize the crimping of the hose at the ground or supporting surface.

[Figure 5, p. 14](#) shows an **incorrect** hose installation. In this configuration the hose is installed without an elbow and with an elevation greater than 7 feet off the ground. This creates excessive stress at the hose coupling connection, causing the hose to stretch and separate from the coupling. It also causes the hose to crimp at the ground.

Figure 5. Incorrect vertical hose installation

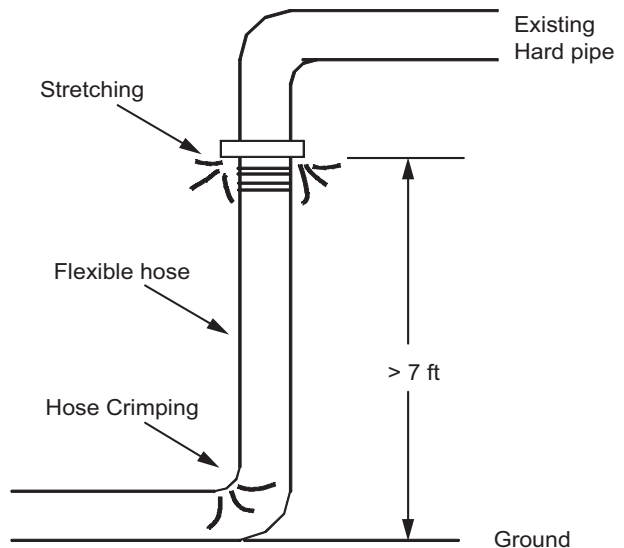

Horizontal to Vertical Installation

Figure 6, p. 15 shows a **correct** vertical/horizontal hose installation. In this configuration, correct installation techniques followed are:

- Hose is installed with elbows at both connection ends.
- Vertical run of hose is less than 7 feet.
- Hose is adequately supported by more than half its total length on the ground.

These items minimize the stretching and separation at the hose-coupling interface and also the crimping of the hose at the ground.

Figure 6. Correct horizontal/vertical installation

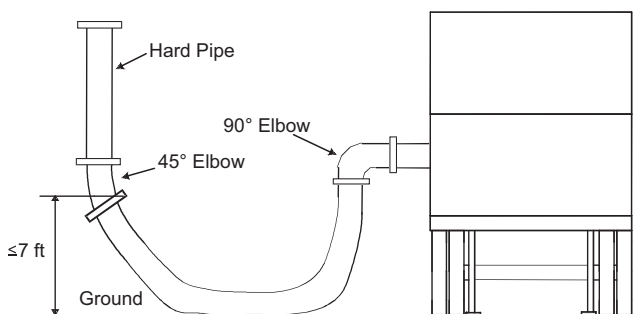

Figure 7, p. 15 shows an **incorrect** vertical/horizontal hose installation. In this configuration, a number of improper installation techniques can be noted:

- Elbows are not installed.
- Hose is completely supported by the couplings.
- Vertical run of hose is greater than 7 feet.
- Hose is not adequately supported by the ground.

These items cause excessive stress to be generated at the hose-coupling interface, causing the hose to stretch and separate from the coupling.

Figure 7. Incorrect horizontal/vertical installation

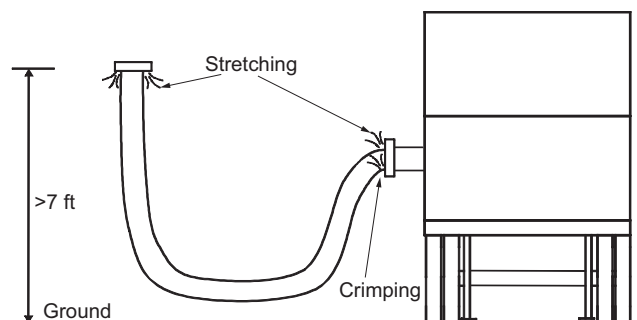
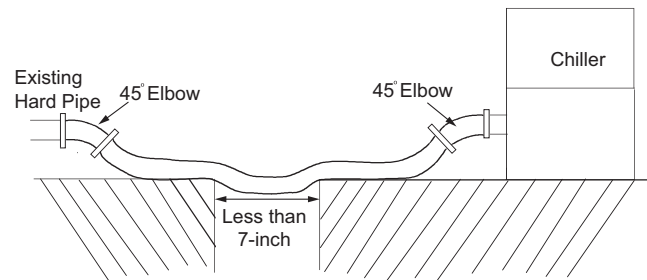

Figure 8, p. 15 illustrates a **correct** horizontal hose installation where there is a section of unsupported hose. The length of unsupported hose should be less than 7-inch. Also, the hose must be adequately supported by having more than half its total length on the ground.

Figure 8. Correct unsupported horizontal installation



Material Disposition

In the event the hose fails or leaks, contact Trane Rental Services. Mark the problem area and tag the hose **BAD** and place it back in the shipping box.

Hard Pipe Installation

Certain installations may require the use of hard pipe (steel or PVC). Hard pipe is typically recommended for the following installations:

- Indoor installations
- Vertical installations greater than 7 feet
- Installations on the suction side of a pump where negative pressure may cause the flexible hose to collapse and restrict flow.
- Semi-permanent installations (three months or more) and/or
- Installations with space limitations

When installing hard pipe:

- Construct and install the piping according to the local and national codes.
- Isolate and support the piping as required to prevent stress on the unit and vibration to building piping.

For water installation piping questions, contact Trane Rental Services.

Trane - by Trane Technologies (NYSE: TT), a global climate innovator - creates comfortable, energy efficient indoor environments for commercial and residential applications. For more information, please visit trane.com or tranetechnologies.com.

Trane has a policy of continuous product and product data improvement and reserves the right to change design and specifications without notice. We are committed to using environmentally conscious print practices.