



Installation, Operation, and Maintenance

Air-Cooled Scroll Chillers

Model CGAM

with Symbio™ Controls
20 to 130 Nominal Tons (60 Hz)



⚠ SAFETY WARNING

Only qualified personnel should install and service the equipment. The installation, starting up, and servicing of heating, ventilating, and air-conditioning equipment can be hazardous and requires specific knowledge and training. Improperly installed, adjusted or altered equipment by an unqualified person could result in death or serious injury. When working on the equipment, observe all precautions in the literature and on the tags, stickers, and labels that are attached to the equipment.



Introduction

Read this manual thoroughly before operating or servicing this unit.

Warnings, Cautions, and Notices

Safety advisories appear throughout this manual as required. Your personal safety and the proper operation of this machine depend upon the strict observance of these precautions.

The three types of advisories are defined as follows:



Indicates a potentially hazardous situation which, if not avoided, could result in death or serious injury.



Indicates a potentially hazardous situation which, if not avoided, could result in minor or moderate injury. It could also be used to alert against unsafe practices.



Indicates a situation that could result in equipment or property-damage only accidents.

Important Environmental Concerns

Scientific research has shown that certain man-made chemicals can affect the earth's naturally occurring stratospheric ozone layer when released to the atmosphere. In particular, several of the identified chemicals that may affect the ozone layer are refrigerants that contain Chlorine, Fluorine and Carbon (CFCs) and those containing Hydrogen, Chlorine, Fluorine and Carbon (HCFCs). Not all refrigerants containing these compounds have the same potential impact to the environment. Trane advocates the responsible handling of all refrigerants.

Important Responsible Refrigerant Practices

Trane believes that responsible refrigerant practices are important to the environment, our customers, and the air conditioning industry. All technicians who handle refrigerants must be certified according to local rules. For the USA, the Federal Clean Air Act (Section 608) sets forth the requirements for handling, reclaiming, recovering and recycling of certain refrigerants and the equipment that is used in these service procedures. In addition, some states or municipalities may have additional requirements that must also be adhered to for responsible management of refrigerants. Know the applicable laws and follow them.

⚠ WARNING

Proper Field Wiring and Grounding Required!

Failure to follow code could result in death or serious injury.

All field wiring **MUST** be performed by qualified personnel. Improperly installed and grounded field wiring poses **FIRE** and **ELECTROCUTION** hazards. To avoid these hazards, you **MUST** follow requirements for field wiring installation and grounding as described in **NEC** and your local/state/national electrical codes.

⚠ WARNING

Personal Protective Equipment (PPE) Required!

Failure to wear proper PPE for the job being undertaken could result in death or serious injury.

Technicians, in order to protect themselves from potential electrical, mechanical, and chemical hazards, **MUST** follow precautions in this manual and on the tags, stickers, and labels, as well as the instructions below:

- **Before installing/servicing this unit, technicians MUST put on all PPE required for the work being undertaken (Examples; cut resistant gloves/sleeves, butyl gloves, safety glasses, hard hat/bump cap, fall protection, electrical PPE and arc flash clothing). ALWAYS refer to appropriate Safety Data Sheets (SDS) and OSHA guidelines for proper PPE.**
- **When working with or around hazardous chemicals, ALWAYS refer to the appropriate SDS and OSHA/GHS (Global Harmonized System of Classification and Labelling of Chemicals) guidelines for information on allowable personal exposure levels, proper respiratory protection and handling instructions.**
- **If there is a risk of energized electrical contact, arc, or flash, technicians MUST put on all PPE in accordance with OSHA, NFPA 70E, or other country-specific requirements for arc flash protection, PRIOR to servicing the unit. NEVER PERFORM ANY SWITCHING, DISCONNECTING, OR VOLTAGE TESTING WITHOUT PROPER ELECTRICAL PPE AND ARC FLASH CLOTHING. ENSURE ELECTRICAL METERS AND EQUIPMENT ARE PROPERLY RATED FOR INTENDED VOLTAGE.**

⚠ WARNING**Follow EHS Policies!**

Failure to follow instructions below could result in death or serious injury.

- All Trane personnel must follow the company's Environmental, Health and Safety (EHS) policies when performing work such as hot work, electrical, fall protection, lockout/tagout, refrigerant handling, etc. Where local regulations are more stringent than these policies, those regulations supersede these policies.
- Non-Trane personnel should always follow local regulations.

⚠ WARNING**R-454B Flammable A2L Refrigerant!**

Failure to use proper equipment or components as described below could result in equipment failure, and possibly fire, which could result in death, serious injury, or equipment damage.

The equipment described in this manual uses R-454B refrigerant which is flammable (A2L). Use ONLY R-454B rated service equipment and components. For specific handling concerns with R-454B, contact your local representative.

⚠ WARNING**Hazardous Service Procedures!**

Failure to follow all precautions in this manual and on the tags, stickers, and labels could result in death or serious injury.

Technicians, in order to protect themselves from potential electrical, mechanical, and chemical hazards, MUST follow precautions in this manual and on the tags, stickers, and labels, as well as the following instructions: Unless specified otherwise, disconnect all electrical power including remote disconnect and discharge all energy storing devices such as capacitors before servicing. Follow proper lockout/tagout procedures to ensure the power can not be inadvertently energized. When necessary to work with live electrical components, have a qualified licensed electrician or other individual who has been trained in handling live electrical components perform these tasks.

Copyright

This document and the information in it are the property of Trane, and may not be used or reproduced in whole or in part without written permission. Trane reserves the right to

revise this publication at any time, and to make changes to its content without obligation to notify any person of such revision or change.

Trademarks

All trademarks referenced in this document are the trademarks of their respective owners.

Factory Training

Factory training is available through Trane University™ to help you learn more about the operation and maintenance of your equipment. To learn about available training opportunities contact Trane University™.

Online: www.trane.com/traneuniversity

Email: traneuniversity@trane.com

Factory Warranty Information

Compliance with the following is required to preserve the factory warranty:

All Unit Installations

Start-up MUST be performed by Trane, or an authorized agent of Trane, to VALIDATE this WARRANTY. Contractor must provide a two-week start-up notification to Trane (or an agent).

Product Safety Information

This appliance is not intended for use by persons (including children) with reduced physical, sensory or mental capabilities, or lack of experience and knowledge, unless they have been given supervision or instruction concerning use of the appliance by a person responsible for their safety. Children should be supervised to ensure that they do not play with the appliance.

Maximum altitude of use 3000 meters.

This appliance incorporates an earth connection for functional purposes only.

Revision History

- Updated Digit 17 – Structural Options and Digit 39 – Installation Accessories in Model Number Description chapter.
- Updated the Accessory/Options Information section in General Information chapter.
- Added a note to Mounting locations, 130 tons figure in Dimensions chapter.
- Added Elastomeric pads section to the Installation - Mechanical chapter.
- Updated Unit wiring table in Unit Wiring chapter.



Table of Contents

Model Number Information	6	Location Requirements	33
Nameplates	6	Sound Considerations	33
Unit Nameplate	6	Foundation	33
Model Number Coding System	6	Clearances	33
Compressor Nameplate	6	Rigging	33
Model Number Description	7	Lifting Procedure	33
Unit Model Number	7	Unit Isolation and Leveling	34
Compressor Model Number Description	9	General	34
General Information	10	Isolator Options	34
Unit Description	10	Isolator Selection and Placement	36
Accessory/Options Information	10	Evaporator Piping	40
General Data	13	Drainage	40
Pre-Installation	15	Evaporator Piping Components	40
Inspection Checklist	15	Entering Chilled Water Piping	41
Unit Storage	15	Leaving Chilled Water Piping	41
Installation Requirements	15	Water Strainer	41
Dimensions	17	Flow Switch	41
Unit Dimensions	17	Evaporator Label	43
Unit Without Options	17	Pressure Drop Curves	43
Unit With Options Pump Package, Buffer Tank	19	Ambient Freeze Avoidance	44
Service Clearances	23	Low Evap Refrigerant Cutout/ Percent Glycol Recommendations	45
Mounting Locations	24	Performance Adjustment Factors	49
Weights	29	Dual High Head Pump Package	49
Base Units	29	Pressure Drop Information - Units with Optional Pump Package	51
A2L Work Procedures	30	Pump Package Requirements	54
Servicing	30	Expansion Tank - Maximum Loop Volume	55
Ignition Source Mitigation	30	Installation Electrical	57
Ventilation	30	General Recommendations	57
Refrigerating Equipment	30	Installer-Supplied Components	57
Electrical Devices	30	Power Supply Wiring	58
Leak Detection	31	Control Power Supply	58
Refrigerant Removal and Evacuation	31	Heater Power Supply	58
Refrigerant Charging	32	Partial Heat Recovery Power Supply	59
Decommissioning	32	Water Pump Power Supply	59
Installation - Mechanical	33	Interconnecting Wiring	59
		Chilled Water Flow (Pump) Interlock	59
		Chilled Water Pump Control	59
		Chilled Water Pump Control — Field Supplied Dual Pumps	60

Chilled Water Pump Control — Optional Pump Package	60	Start-Up	76
Alarm and Status Relay Outputs (Programmable Relays)	60	Seasonal Unit Start-Up Procedure	76
Relay Assignments Using Tracer® TU	62	Seasonal Unit Shutdown	76
Low Voltage Wiring	62	Sequence of Operation	77
Emergency Stop	62	Software Operation Overview	77
External Auto/Stop	62	Power Up Diagram	78
Ice Building Option	62	Power Up to Starting	78
External Chilled Water Setpoint (ECWS) Option	63	Stopped to Starting	79
External Demand Limit Setpoint (EDLS) Option	63	Normal Shutdown to Stopped or Run Inhibit	79
ECWS and EDLS Analog Input Signal Wiring Details	64	Maintenance	81
Chilled Water Reset (CWR)	64	Recommended Maintenance	81
Percent Capacity Output Option	65	Weekly	81
Communications Interface	65	Monthly	81
LonTalk Interface (LCI-C)	65	Annual	81
BACnet Interface (BCI-C)	65	Refrigerant and Oil Charge Management	82
Modbus® Remote Terminal Unit Interface	65	Lubrication System	82
Operating Principles	66	Oil Level	82
General	66	Oil Testing	82
Base Units	66	Condenser Maintenance	83
Pump Package Components - Optional	69	Round Tube Plate Fin Condensers	83
Refrigerant Cycle	72	Evaporator Maintenance	83
Refrigerant Cycle Description	72	Water Strainer Maintenance	83
Oil System Operation (CGAM)	73	Pump Package Maintenance	84
Sensor Requirements	73	Rust Prevention	84
Controls	74	Diagnostics	85
Overview	74	General Diagnostics Information	85
Symbio 800	74	Main Processor Diagnostics	85
AdaptiView Display	74	Sensor Failure Diagnostic	90
Tracer TU	74	Communication Diagnostics	91
Pre-Start Checkout	75	Unit Wiring	95
Start-Up and Shutdown	76	Log and Check Sheet	96
		CGAM Air-Cooled Scroll Chiller Installation Completion Check Sheet and Request for Trane Service	97



Model Number Information

Nameplates

Unit nameplates are located as follows:

- 20 to 70 ton units: exterior surface of control panel door
- 80 to 120 ton units: support beam to the right of the starter panel

A compressor nameplate is located on each compressor.

Unit Nameplate

The unit nameplate provides the following information:

- Model
- Serial Number
- Electrical requirements
- Operating charges of refrigerant and oil
- Design pressures
- Installation, operation, and maintenance and service literature
- Drawing numbers for unit wiring diagrams

Model Number Coding System

The model numbers are composed of numbers and letter which represent features of the equipment.

Each position, or group of positions, in a model number or letter is used to represent a feature. Unit model number digits are selected and assigned as listed in the Model Number Descriptions chapter.

Compressor Nameplate

The compressor nameplate provides the following information:

- Compressor model number
- Compressor serial number
- Compressor electrical characteristics
- Utilization Range
- Recommended refrigerant



Model Number Description

Unit Model Number

Digit 1, 2, 3, 4 – Unit Model

CGAM = Air-Cooled Scroll Packaged Chiller

Digit 5, 6, 7 – Nominal Tonnage

020 = 20 Tons
026 = 26 Tons
030 = 30 Tons
035 = 35 Tons
040 = 40 Tons
052 = 52 Tons
060 = 60 Tons
070 = 70 Tons
080 = 80 Tons
090 = 90 Tons
100 = 100 Tons
110 = 110 Tons
120 = 120 Tons
130 = 130 Tons

Digit 8 – Unit Voltage

A = 200V/60Hz/3 phase
B = 230V/60Hz/3 phase
D = 380V/60Hz/3 phase
F = 460V/60Hz/3 phase
G = 575V/60Hz/3 phase

Digit 9 – Manufacturing Location

2 = Trane Commercial Systems, Pueblo, CO USA

Digits 10, 11 – Design Sequence

** = Factory assigned

Digit 12 – Unit Type

2 = High Efficiency
3 = Extra Efficiency

Digit 13 – Agency Listing

X = No Agency Listing
E = ETL Listed/Certified to CSA/Conforms to UL

Digit 14 – Pressure Vessel Code

X = Not Applicable
1 = CRN or Canada Equivalent

Digit 15 – Unit Application

B = High Ambient (32-125°F/0-52°C)
D = Wide Ambient (0-125°F/-18-52°C)
J = Extreme Low Ambient — down to -20°F (-28.9°C)

Digit 16 – Refrigerant Isolation Valves

2 = Refrigerant Isolation Valves (Discharge)

Digit 17 – Structural Options

A = Standard Unit Structure
B = Seismic to International Building Code (IBC)
C = California Office of Statewide Health Planning and Development (OSHPD)
D = Wind Load for Florida Hurricane

Digit 18 – Freeze Protection (Factor-Installed Only)

X = Without Freeze Protection
1 = With Freeze Protection (External T-Stat control)

Digit 19 – Insulation

A = Factory Insulation - All Cold Parts
B = Insulation for High Humidity/Low Evap Temp

Digit 20 – Factory Charge

3 = Full Factory Refrigerant Charge R-454B
4 = Nitrogen Charge — R-454B Field Supplied

Digit 21 – Evaporator Application

A = Standard Cooling (40 to 65°F/4.4 to 18°C)
B = Low Temperature Process (10 to 40°F/-12.2 to 4.4°C)
C = Ice-Making - Hardwired Interface (20 to 65°F/-7 to 18°C)
D = Low Leaving Water (Below 10°F/-12.2°C)

Digit 22 – Water Connections

1 = Grooved Pipe Connection

Digit 23 – Condenser Fin Material

A = Lanced Aluminum Fins
D = Lanced Aluminum Fins with CompleteCoat™

Digit 24 – Condenser Heat Recovery

X = No Heat Recovery

Digit 25 – Not Used

Digit 26 – Starter Type

A = Across the Line Starter/Direct On Line

Digit 27 – Incoming Power Line Connection

1 = Single Point Power Connect

Digit 28 – Power Line Connection Type

A = Terminal Block
C = Circuit Breaker Standard Fault
D = Circuit Breaker with High Fault Rated Control Panel
E = Circuit Breaker with High Fault Rated Control Panel with Energy Meter

Digit 29 – Enclosure Type

2 = Enclosure type UL 60335 Rated for Outdoor Applications

Digit 30 – Unit Operator Interface

B = Tracer® AdaptiView™ TD-7

Digit 31 – Remote Interface (Digital Comm)

X = No Remote Digital Communication
2 = LonTalk®/Tracer® Summit Interface
4 = BACNet® Interface

Digit 32 – External Chilled/Hot Water and Current Demand Limit Setpoint

X = No External Chilled Water Setpoint
A = External Chilled Water and Demand Limit Setpoint 4-20 mA
B = External Chilled Water and Demand Limit Setpoint 2-10 Vdc

Digit 33 – Percent Capacity

X = Without Percent Capacity
1 = With Percent Capacity

Digit 34 – Programmable Relays

X = No Programmable Relays
A = With Programmable Relays

Digit 35 – Pump Type

X = No Pumps and No Contactors
8 = Dual High Head Pump



Model Number Description

Digit 36 – Pump Flow Control

X = No Pump Control
B = Pump Flow Controlled by the Variable Speed Drive

Digit 37 – Buffer Tank

X = No Buffer Tank
1 = Buffer Tank

Digit 38 – Short Circuit Rating

X = No Short Circuit Rating
A = Default A Short Circuit Rating
B = High A Short Circuit Rating

Digit 39 – Installation Accessories

X = No Installation Accessories
1 = Elastomeric Isolators
3 = Seismic Neoprene Pads
5 = Elastomeric Pads

Digit 40 – Water Strainer

A = With Water Strainer Factory Installed

Digit 41 – Sound Attenuator Package

3 = Super Quiet
5 = Comprehensive Acoustic Package

Digit 42 – Appearance Options

X = No Appearance Options
A = Architectural Louvered Panels
B = Half Louvers

Digit 43 – Exterior Finish

1 = Standard Paint

Digit 44 – Label, Literature Language

B = Spanish and English
D = English
E = French and English

Digit 45 – Phase Reversal Protection

1 = Phase Reversal Protection
2 = Convenience Outlet and Phase Reversal Protection

Digit 46 – Shipping Package

X = No Skid (Standard)
A = Unit Containerization Package
B = Shipped with tarp Covering Full Unit
C = Unit Containerization Package and Tarp

Digit 47 – Performance Test Options

X = No Performance Test
1 = Customer Inspection
2 = One-Point Test with Report
3 = Witness One-Point Test with Report
4 = Operational Test with Water

Digit 48 – Flow Switch Setpoint

C = Flow Switch Setpoint 15
F = Flow Switch Setpoint 35
H = Flow Switch Setpoint 45
L = Flow Switch Setpoint 60

Digit 49 – Wireless Connectivity Options

X = None
A = Wi-Fi®
B = LTE Modem
C = Air-Fi™
D = Wi-Fi and LTE Modem
E = Wi-Fi and Air-Fi
F = LTE Modem and Air-Fi
G = Wi-Fi, LTE Modem and Air-Fi

Digit 50 – Specials

X = None
S = Special

Note: If a digit is not defined, it may be held for future use.

Compressor Model Number Description

Digit 1, 2, 3, 4 — Compressor Model

CSHE = Light Commercial Scroll with Intermediate Discharge Port

CSHP = Commercial Scroll with Intermediate Discharge Port

Digit 5, 6, 7 — Capacity

117 = CSHE 10T

152 = CSHE 13T

177 = CSHE 15T

237 = CSHP 20T

297 = CSHP 25T

346 = CSHP 30T

Digit 8 — Voltage

J = 200–230V/60Hz/3 phase

K = 460V/60Hz/3 phase – 400/50/3 phase

F = 230V/50Hz/3 phase

D = 575V/60Hz/3 phase

X = 380V/60Hz/3 phase

Digit 9 — Unloading

0 = No Unloading

Digits 10 — Design Sequence

Factory assigned

Digit 11 — Protection Module Voltage

0 = Internal Line Break

A = 115 Vac

B = 230 Vac

H = 24 Vac

K = 115/230 Vac

Digit 12 — Basic Compressor Variation

C = Suction and Discharge Tube, Oil Equalizer with Seal Nut, Grade 32 POE oil

D = Suction and Discharge Tube, Oil Equalizer with Seal Nut, Oil Dip Tube, Grade 32 POE oil



General Information

Unit Description

The CGAM units are scroll type, air-cooled, liquid chillers, designed for installation outdoors. The 20 to 35 ton units have a single independent refrigerant circuit, with two compressors per circuit. The 40 ton and larger units have 2 independent refrigerant circuits, with two compressors per circuit. The CGAM units are packaged with an evaporator and condenser.

Note: Each factory-charged CGAM unit (model number digit 20 = 3), is a completely assembled, hermetic-compressors packaged unit that is factory-piped, wired, leak-tested, dehydrated, charged and tested for proper control operations prior to shipment. The chilled water inlet and outlet openings are covered for shipment.

The CGAM series features Trane's exclusive Adaptive Control logic with Symbio™ 800 controls. It monitors the control variables that govern the operation of the chiller unit. Adaptive Control logic can correct these variables, when necessary, to optimize operational efficiencies, avoid chiller shutdown, and keep producing chilled water.

Each refrigerant circuit is provided with filter, sight glass, electronic expansion valve, and charging valves on the CGAM.

The evaporator is a brazed plate heat exchanger which is equipped with a water drain and vent connections in the water piping. The condenser is an air-cooled slit or serpentine fin coil.

The condensers are available in three configurations depending on the tonnage of the unit. Units may be referred to the size by the condenser configuration. The three configurations are slant, V and W.

Figure 1. CGAM slant 20 to 35 ton configuration

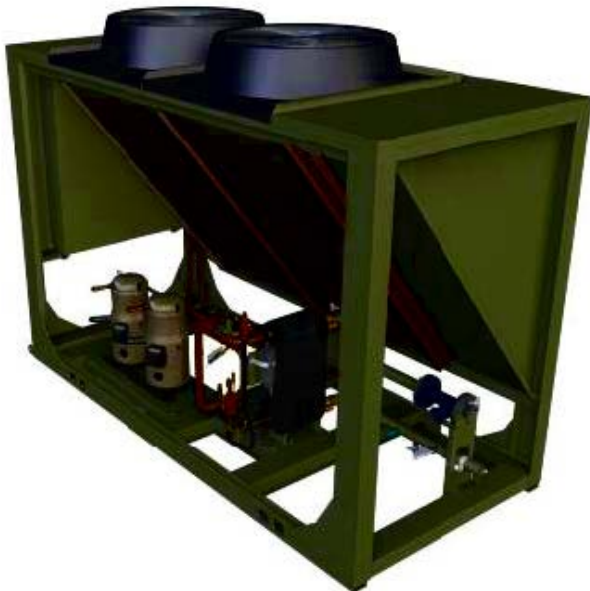

Figure 2. CGAM “V” 40 to 70 ton configuration

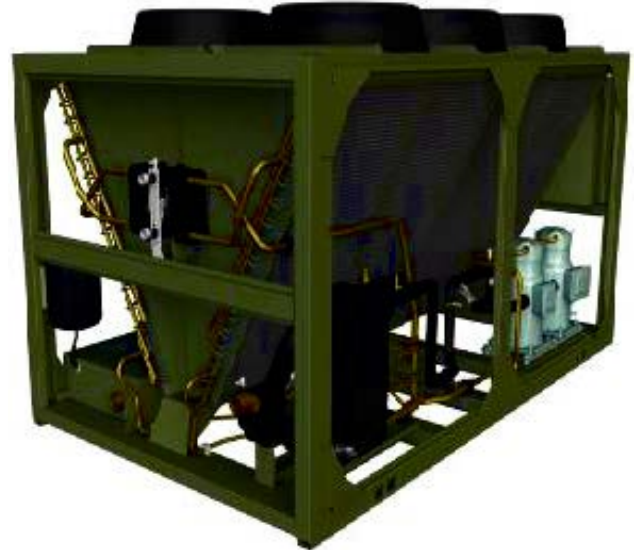

Figure 3. CGAM “W” 80 to 130 ton configuration



Accessory/Options Information

Check all the accessories and loose parts which are shipped with the unit against the original order. Included in these items will be rigging diagrams, electrical diagrams, and service literature, which are placed inside the control panel and/or starter panel for shipment. Also check for optional components, such as isolators.

The unit elastomeric Isolators and fan prop rod ship on brackets attached to the frame of the unit. The location varies by unit tonnage. The following figures show the location of these ship-with items for the various unit sizes.

Elastomeric pads required for units with seismic and/or wind load rating ship inside the control panel.

Figure 4. Ship with location — elastomeric isolators and prop rod 20 to 35 ton units

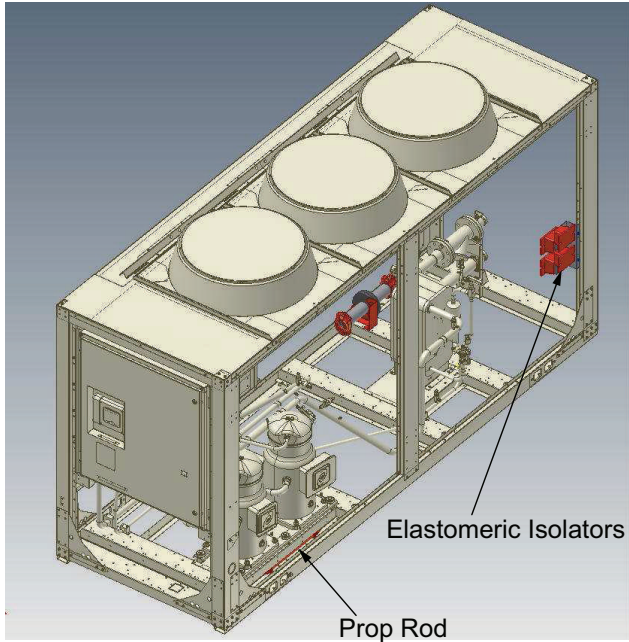

Figure 5. Ship with location — elastomeric isolators and prop rod 40 to 70 ton units

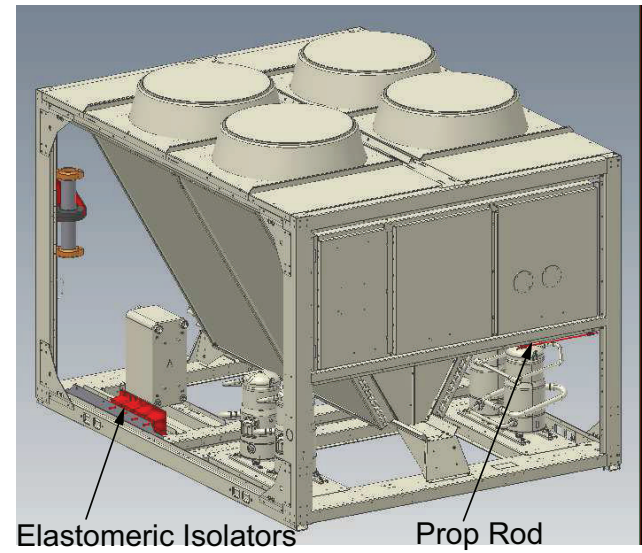
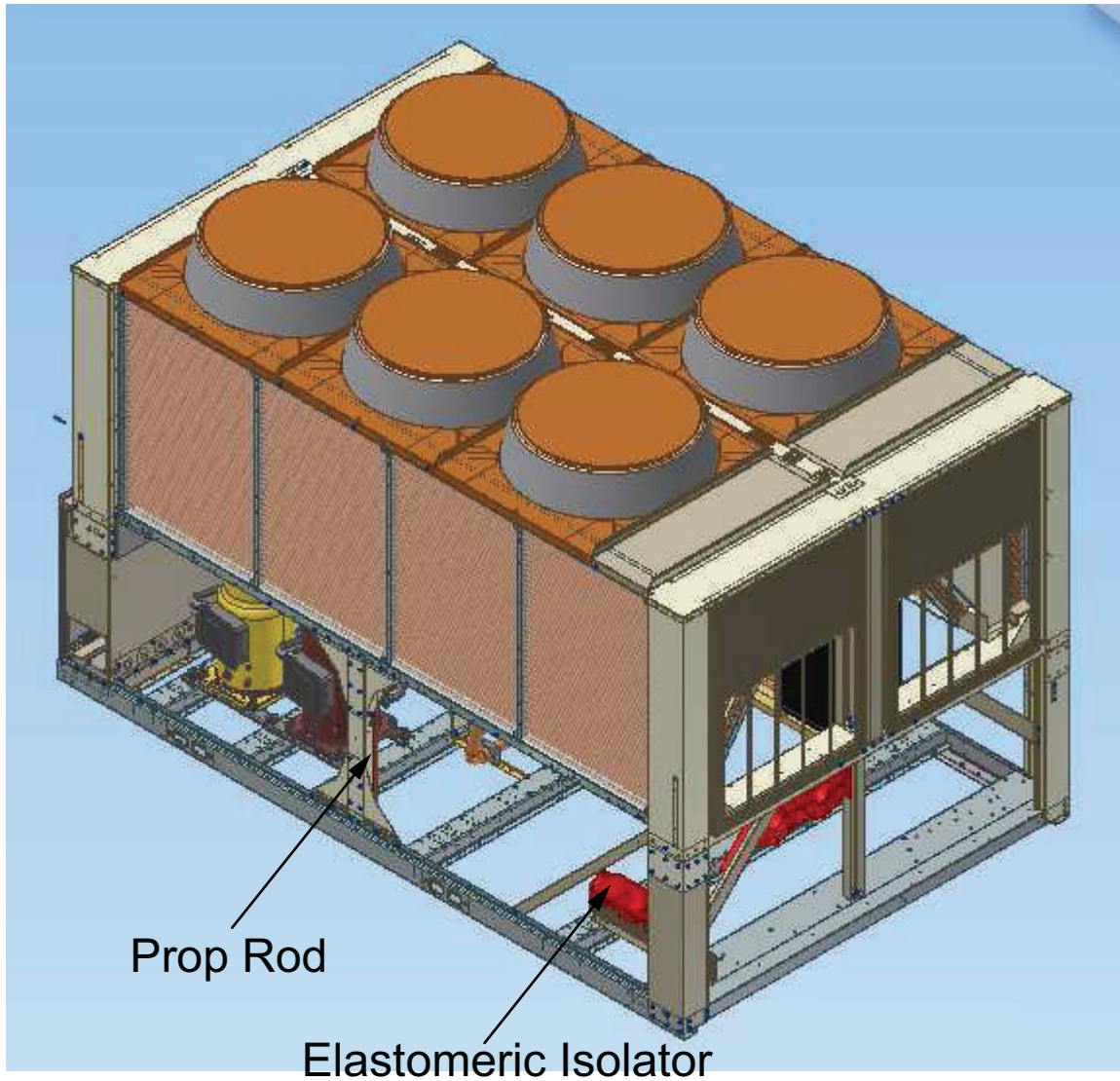

Figure 6. Ship with location — elastomeric isolator and prop rod 80 to 130 ton units



General Data

Table 1. General data, 60 Hz (I-P)

Size	Unit	20	26	30	35	40	52	60	70	80	90	100	110	120	130
Compressor															
Number	#	2	2	2	2	4	4	4	4	4	4	4	4	4	6
Tonnage/ckt		10+10	13+13	15+15	15+20	10+10	13+13	15+15	15+20	20+20	20+25	25+25	25+30	30+30	20+20 +25
Evaporator															
Water storage	gal	1.4	2.2	2.2	2.8	3.4	4.1	5	6.3	7	8.6	10.3	10.3	11.5	11.5
Min. flow ^(a) (LWT ≥42°F)	gpm	23.2	29.8	33.1	38.5	45	58.8	67.1	79.5	91.8	102.6	115.5	125.2	135.9	146.9
Min. flow ^(a) (LWT 40 to 41.9°F)	gpm	29.1	37.2	41.8	48.2	56.3	73.5	83.9	99.4	114.7	128.3	144.4	156.5	169.9	183.7
Max. flow ^(a)	gpm	69	89	100	115	134.8	176	201	238	275	307	346	375	407	440
Water connection	in.	2.0	2.5	2.5	2.5	3.0	3.0	3.0	3.0	4.0	4.0	4.0	4.0	4.0	4.0
Max. Water Temperature	°F	105	105	105	105	105	105	105	105	105	105	105	105	105	105
Min. Water Pressure	psig	0	0	0	0	0	0	0	0	0	0	0	0	0	0
Max. Water Pressure	psig	150	150	150	150	150	150	150	150	150	150	150	150	150	150
Condenser															
Quantity of coils	#	1	1	1	1	2	2	2	2	4	4	4	4	4	4
Coil length	in.	91	91	127	127	91	91	127	127	121	121	144	144	144	180
Coil height	in.	68	68	68	68	68	68	68	68	42	42	42	42	42	42
Number of rows	#	3	3	3	3	3	3	3	3	3	3	3	3	3	3
Fins per foot	fpf	192	192	192	192	192	192	192	192	192	192	192	192	192	192
Fan															
Quantity	#	2	2	3	3	4	4	6	6	6	6	8	8	8	10
Diameter	in.	28.8	28.8	28.8	28.8	28.8	28.8	28.8	28.8	28.8	28.8	28.8	28.8	28.8	28.8
Airflow per fan	cfm	9413	9420	9168	9173	9413	9420	9168	9173	9470	9472	9094	9096	9098	9094
Power per motor	HP	1.3	1.3	1.3	1.3	1.3	1.3	1.3	1.3	1.3	1.3	1.3	1.3	1.3	1.3
Motor RPM	rpm	840	840	840	840	840	840	840	840	840	840	840	840	840	840
Tip speed	ft/min	6333	6333	6333	6333	6333	6333	6333	6333	6333	6333	6333	6333	6333	6333
General Unit															
Refrig circuits	#	1	1	1	1	2	2	2	2	2	2	2	2	2	2
Capacity steps	%	50-100	50-100	50-100	43-100	25-50- 75-100	25-50- 75-100	25-50- 75-100	21-43- 71-100	25-50- 75-100	22-44- 72-100	25-50- 75-100	23-45- 73-100	25-50- 75-100	15-31- 46-62- 81-100
Min ambient - wide	°F	0	0	0	0	0	0	0	0	0	0	0	0	0	0
Min ambient - high	°F	32	32	32	32	32	32	32	32	32	32	32	32	32	32
Min ambient - extreme low	°F	-20	-20	-20	-20	-20	-20	-20	-20	-20	-20	-20	-20	-20	-20
Refrig charge/ckt ^(b)	lbs	35	37	48	51	34	38	51	52	67	69	81	74	77	93
Oil charge/ckt ^(b)	gal	1.9	1.9	2.1	2.7	1.9	1.9	2.1	2.7	3.9	3.9	3.8	4.1	4.2	7.2
Pump Package															
Avail head pressure ^(c)	ft H2O	78.2	77.7	71.1	67.6	67.1	58.6	76.7	63.5	82	78.1	69	61.9	71.3	62.2
Power	HP	5.0	5.0	5.0	5.0	5.0	5.0	7.5	7.5	10.0	10.0	10.0	10.0	15.0	15.0
Expansion tank volume	gal	5	5	5	5	5	5	5	5	6	6	6	6	6	6
Buffer tank volume	gal	140	140	140	140	140	140	140	140	152	152	195	195	195	195

^(a) Minimum and maximum flow rates apply to constant-flow chilled water system running at AHRI conditions, without freeze inhibitors added to the water loop.

^(b) Data shown for one circuit only. The second circuit always matches.

^(c) Pump available head pressure is based on 44/54°F evaporator with water, .0001 hr-ft²-°F/Btu, 95°F ambient and 0 ft elevation.



General Information

Table 2. General data, 60 Hz (SI)

Size	Unit	20	26	30	35	40	52	60	70	80	90	100	110	120	130
Compressor															
Number	#	2	2	2	2	4	4	4	4	4	4	4	4	4	6
Tonnage/ckt		10+10	13+13	15+15	15+20	10+10	13+13	15+15	15+20	20+20	20+25	25+25	25+30	30+30	20+20 +25
Evaporator															
Water storage	L	5.3	8.3	8.3	10.6	12.9	15.5	18.9	23.8	26.5	32.6	39.0	39.0	43.5	43.5
Min. flow ^(a) (LWT ≥5.56°C)	L/s	1.5	1.9	2.1	2.4	2.8	3.7	4.2	5.0	5.8	6.5	7.3	7.9	8.6	9.3
Min. flow ^(a) (LWT 4.44 to 5.55°C)	L/s	1.8	2.3	2.6	3.0	3.6	4.6	5.3	6.3	7.2	8.1	9.1	9.9	10.7	11.6
Max. flow ^(a)	L/s	4.4	5.6	6.3	7.3	8.5	11.1	12.7	15.0	17.3	19.4	21.8	23.7	25.7	27.8
Water connection	mm	50.8	63.5	63.5	63.5	76.2	76.2	76.2	76.2	101.6	101.6	101.6	101.6	101.6	101.6
Max. Water Temperature	°C	40.5	40.5	40.5	40.5	40.5	40.5	40.5	40.5	40.5	40.5	40.5	40.5	40.5	40.5
Min. Water Pressure	kPa	0	0	0	0	0	0	0	0	0	0	0	0	0	0
Max. Water Pressure	kPa	1034	1034	1034	1034	1034	1034	1034	1034	1034	1034	1034	1034	1034	1034
Condenser															
Qty of coils	#	1	1	1	1	2	2	2	2	4	4	4	4	4	4
Coil length	mm	2311	2311	3226	3226	2311	2311	3226	3226	3073	3073	3658	3658	3658	4572
Coil height	mm	1727	1727	1727	1727	1727	1727	1727	1727	1067	1067	1067	1067	1067	1067
Number of rows	#	2	2	2	2	2	2	2	2	3	3	3	3	3	3
Fins per foot	fpf	192	192	192	192	192	192	192	192	192	192	192	192	192	192
Fan															
Quantity	#	2	2	3	3	4	4	6	6	6	6	8	8	8	10
Diameter	mm	732	732	732	732	732	732	732	732	732	732	732	732	732	732
Airflow per fan	m³/h	15993	16005	15577	15585	15993	16005	15577	15585	16090	16093	15451	15454	15458	15451
Power per motor	HP	1.3	1.3	1.3	1.3	1.3	1.3	1.3	1.3	1.3	1.3	1.3	1.3	1.3	1.3
Motor RPM	rpm	840	840	840	840	840	840	840	840	840	840	840	840	840	840
Tip speed	m/s	32	32	32	32	32	32	32	32	32	32	32	32	32	32
General Unit															
Refrig circuits	#	1	1	1	1	2	2	2	2	2	2	2	2	2	2
Capacity steps	%	50-100	50-100	50-100	43-100	25-50- 75-100	25-50- 75-100	25-50- 75-100	21-43- 71-100	25-50- 75-100	22-44- 72-100	25-50- 75-100	23-45- 73-100	25-50- 75-100	15-31- 46-62- 81-100
Min ambient - wide	°C	-18	-18	-18	-18	-18	-18	-18	-18	-18	-18	-18	-18	-18	-18
Min ambient - high	°C	0	0	0	0	0	0	0	0	0	0	0	0	0	0
Min ambient - extreme low	°C	-28.9	-28.9	-28.9	-28.9	-28.9	-28.9	-28.9	-28.9	-28.9	-28.9	-28.9	-28.9	-28.9	-28.9
Refrig charge/ckt ^(b)	kg	15.9	16.8	21.8	23.1	15.4	17.2	23.1	23.6	30.4	31.3	36.7	33.6	34.9	42.2
Oil charge /ckt ^(b)	L	7.2	7.2	7.9	10.2	7.2	7.2	7.9	10.2	14.8	14.8	14.4	15.5	15.9	27.3
Pump Package															
Avail head pressure ^(c)	kPa	233.7	232.2	212.5	202.1	200.6	175.2	229.3	189.8	245.1	233.4	206.2	185.0	213.1	185.9
Power	HP	5	5	5	5	5	5	7.5	7.5	10	10	10	10	15	15
Expansion tank volume	L	18.9	18.9	18.9	18.9	18.9	18.9	18.9	18.9	22.7	22.7	22.7	22.7	22.7	22.7
Buffer tank volume	L	530	530	530	530	530	530	530	530	575	575	738	738	738	738

(a) Minimum and maximum flow rates apply to constant-flow chilled water system running at AHRI conditions, without freeze inhibitors added to the water loop.

(b) Data shown for one circuit only. The second circuit always matches.

(c) Pump available head pressure is based on 6.7/12.2°C evaporator with water, .01761 m³/C/kW, 35°C ambient and 0 m elevation.



Pre-Installation

Inspection Checklist

When the unit is delivered, verify that it is the correct unit and that it is properly equipped. Compare the information which appears on the unit nameplate with the ordering and submittal information.

Inspect all exterior components for visible damage. Report any apparent damage or material shortage to the carrier and make a unit damage notation on the carriers delivery receipt. Specify the extent and type of damage found and notify the appropriate Trane Sales Office.

Do not proceed with installation of a damaged unit without sales office approval.

To protect against loss due to damage incurred in transit, complete the following checklist upon receipt of the unit.

- Inspect the individual pieces of the shipment before accepting the unit. Check for obvious damage to the unit or packing material.
- Inspect the unit for concealed damage as soon as possible after delivery and before it is stored. Concealed damage must be reported within 15 days.
- If concealed damage is discovered, stop unpacking the shipment. Do not remove damaged material from the receiving location. Take photos of the damage, if possible. The owner must provide reasonable evidence that the damage did not occur after delivery.
- Notify the carriers terminal of the damage immediately, by phone and by mail. Request an immediate, joint inspection of the damage with the carrier and the consignee.

- Notify the Trane sales representative and arrange for repair. Do not repair the unit, however, until damage is inspected by the carriers representative.

Unit Storage

If the chiller is to be stored in ambients of 32°F or less, evaporator should be blown out to remove any liquid and refrigerant isolation valves should be closed.

If the chiller is to be stored for more than one month prior to installation, observe the following precautions:

- Do not remove the protective coverings from the electrical panel.
- Store the chiller in a secure area.
- Units charged with refrigerant should not be stored where temperatures exceed 140°F.
- At least every three months, attach a gauge and manually check the pressure in the refrigerant circuit. If the refrigerant pressure is below 200 psig at 70° F (or 145 psig at 50° F), call a qualified service organization and the appropriate Trane sales office.

Note: Pressure will be approximately 20 psig if shipped with the optional nitrogen charge.

Installation Requirements

A list of the contractor responsibilities typically associated with the unit installation process is provided.

Type	Trane Supplied		Field Supplied Field Installed
	Trane Installed	Field Installed	
Foundation			<ul style="list-style-type: none"> • Meet foundation requirements
Rigging			<ul style="list-style-type: none"> • Safety chains • Clevis connectors • Lifting beam
Isolation		<ul style="list-style-type: none"> • Elastomeric isolators (optional) 	<ul style="list-style-type: none"> • Elastomeric isolators (optional)
Electrical	<ul style="list-style-type: none"> • Circuit breakers (optional) • Unit mounted starter 		<ul style="list-style-type: none"> • Circuit breakers (optional) • Electrical connections to unit mounted starter • Wiring sizes per submittal and NEC • Terminal lugs • Ground connection(s) • BAS wiring (optional) • Control voltage wiring • Chilled water pump contactor and wiring including interlock • Option relays and wiring



Pre-Installation

Type	Trane Supplied		Field Supplied Field Installed
	Trane Installed	Field Installed	
Water Piping	<ul style="list-style-type: none"> Flow switch Water strainer 		<ul style="list-style-type: none"> Taps for thermometers and gauges Thermometers Water flow pressure gauges Isolation and balancing valves in water piping Vents and drain Pressure relief valves
Insulation	<ul style="list-style-type: none"> Insulation High humidity insulation (optional) 		<ul style="list-style-type: none"> Insulation
Water Piping Connection Components	<ul style="list-style-type: none"> Grooved pipe 		
Other Materials	<ul style="list-style-type: none"> R-454B refrigerant (1 lb. max per machine as needed) Dry nitrogen (20 psig max per machine as needed) 		

Dimensions

Unit Dimensions

Unit Without Options

Note: The number of fans shown does not represent the number of fans installed.

Figure 7. Dimensions, 20 to 35 ton units, no options

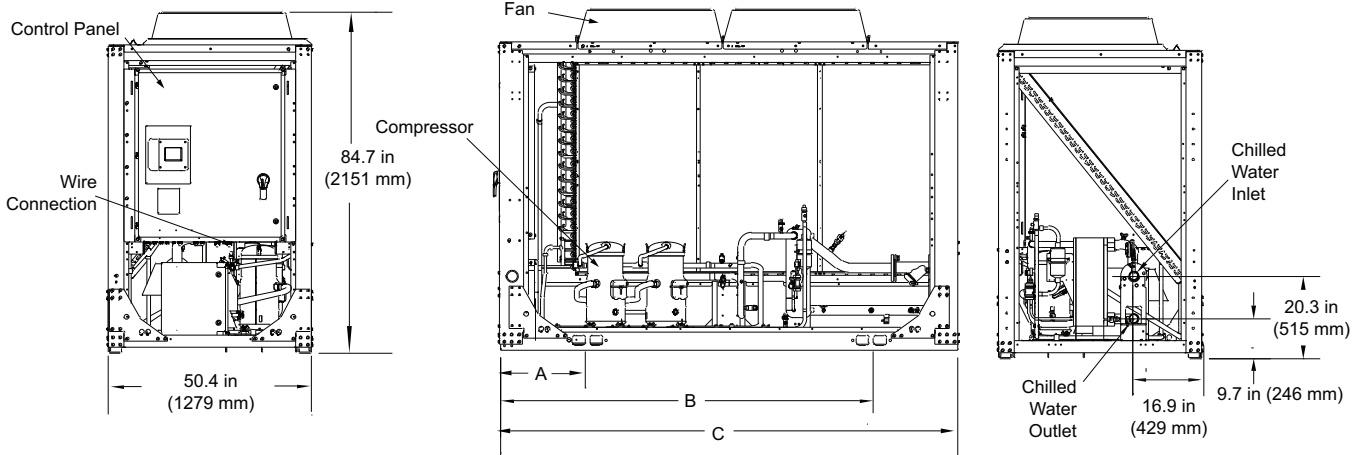
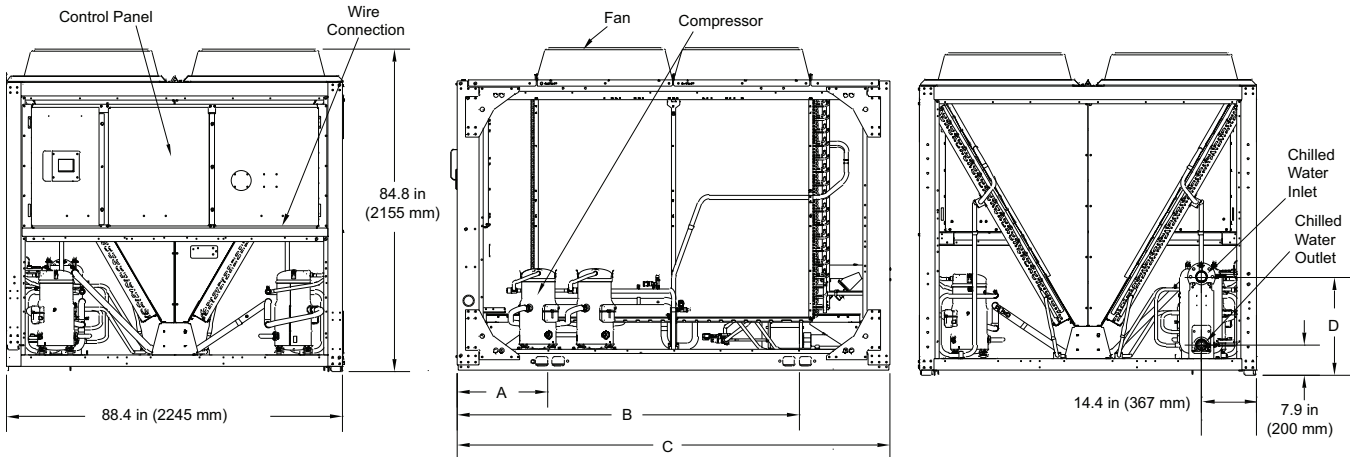

Table 3. Dimensions, 20 to 35 ton units, no options

Unit Size (tons)	A		B		C		Water Connection (from end of chiller)	
	in.	mm	in.	mm	in.	mm	in.	mm
20, 26	21.2	535	92.7	2354	113.8	2890	1.7	44
30, 35	21.3	541	128.4	3263	149.8	3804	1.6	40

Figure 8. Dimensions, 40 to 70 ton units, no options





Dimensions

Table 4. Dimensions, 40 to 70 ton units, no options

Unit Size (tons)	A		B		C		D		Water Connection (from end of chiller)
	in.	mm	in.	mm	in.	mm	in.	mm	
40	23.8	603	89.9	2282	113.8	2890	31.1	790	Even with unit end
52	23.8	603	89.9	2282	113.8	2890	31.1	790	Even with unit end
60, 70	23.8	603	125.8	3196	149.8	3804	31.1	790	Even with unit end

Figure 9. Dimensions, 80 to 120 ton units, no options

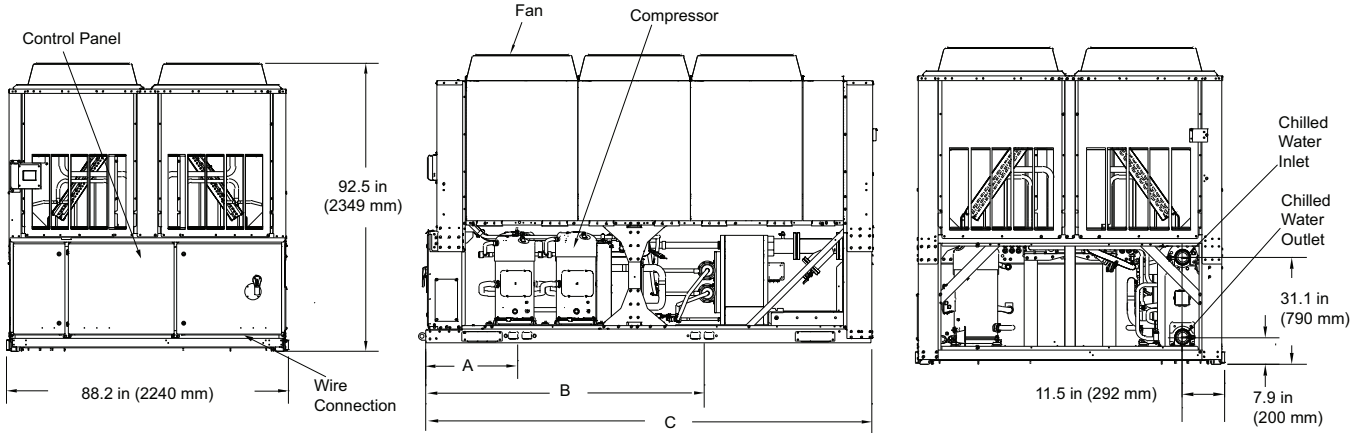
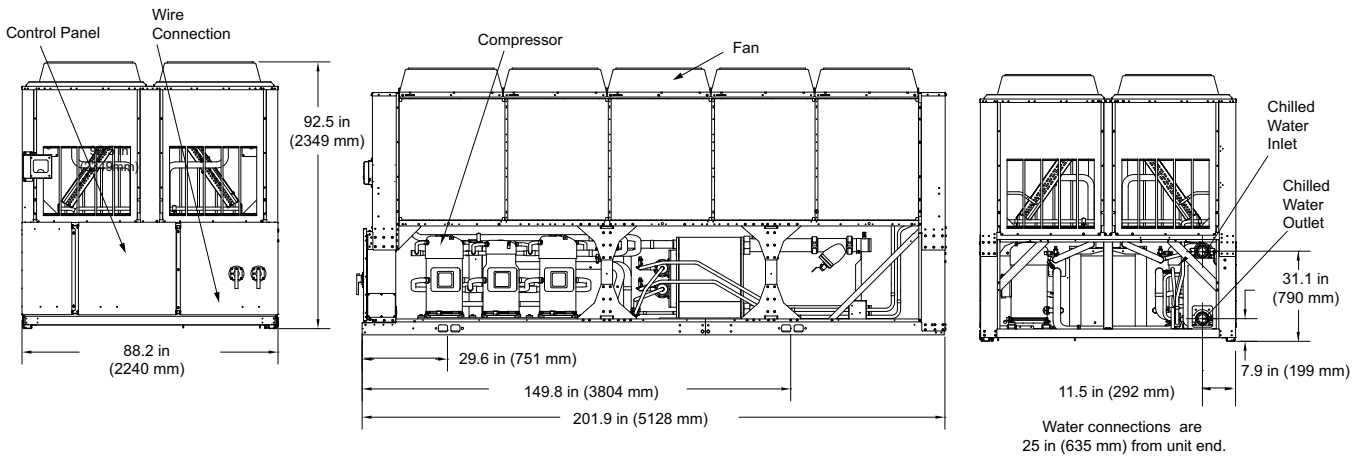

Table 5. Dimensions, 80 to 120 ton units, no options

Unit Size (tons)	A		B		C		Water Connection (from end of chiller)	
	in.	mm	in.	mm	in.	mm	in.	mm
80, 90	29.6	751	89.2	2265	143.1	3634	5.5	139
100, 110, 120	29.6	751	111.7	2837	165.9	4214	5.5	139

Figure 10. Dimensions, 130 ton unit, no options



Unit With Options Pump Package, Buffer Tank

General Dimensions and Components

Notes:

- Graphics in this section, use the following acronyms: PP — Pump Package, BT — Buffer Tank
- See [Table 11, p. 23](#), for dimensions of water connections for various options.

Figure 11. Dimensions, 20 to 35 ton units with options

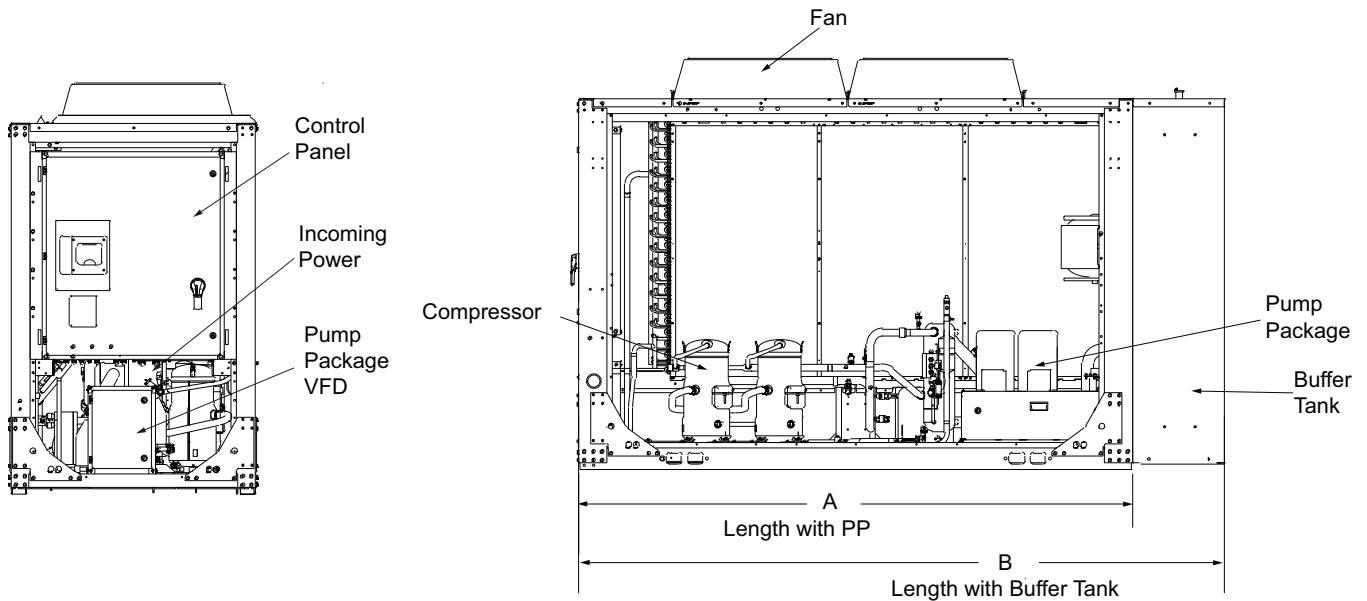

Table 6. Dimensions, 20 to 35 ton units with options

Unit Size (tons)	A		B	
	in.	mm	in.	mm
20, 26	113.8	2890	134	3404
30, 35	149.8	3804	170.1	4320



Dimensions

Figure 12. Dimensions, 40 to 70 ton units with options

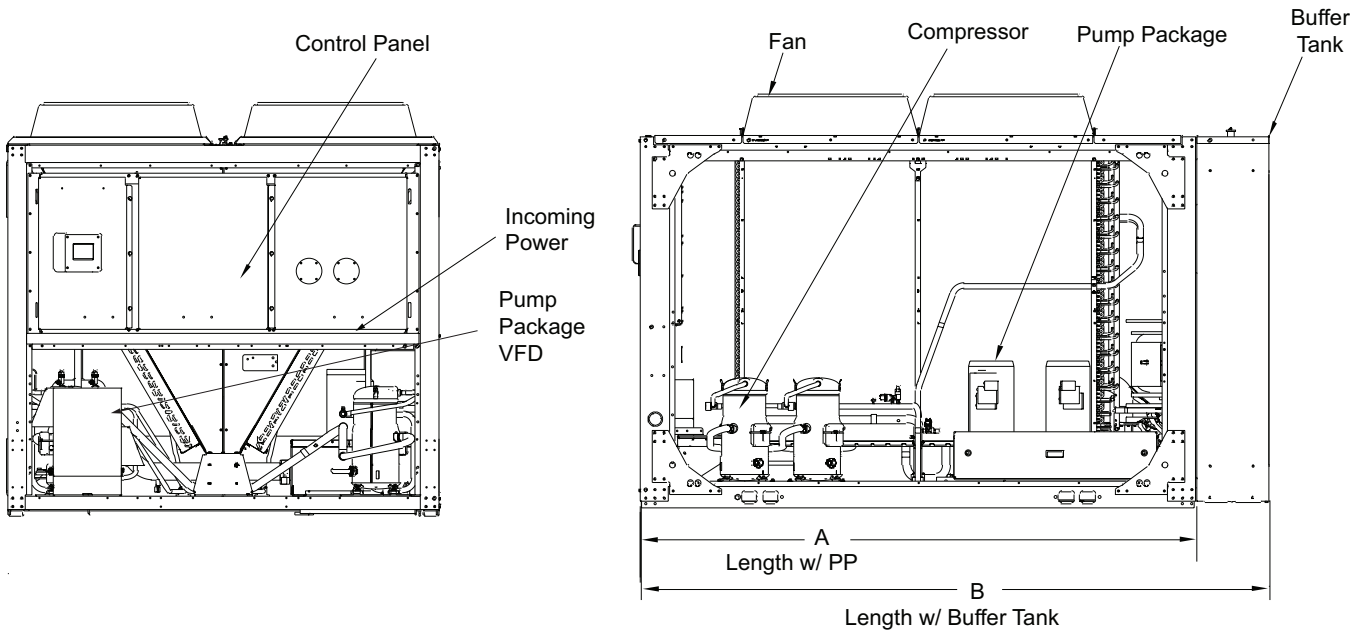

Table 7. Dimensions, 40 to 70 ton units with options

Unit Size (tons)	A		B	
	in.	mm	in.	mm
40, 52	113.8	2890	134.2	3409
60, 70	149.8	3804	170	4318

Figure 13. Dimensions, 80 to 120 ton units with options

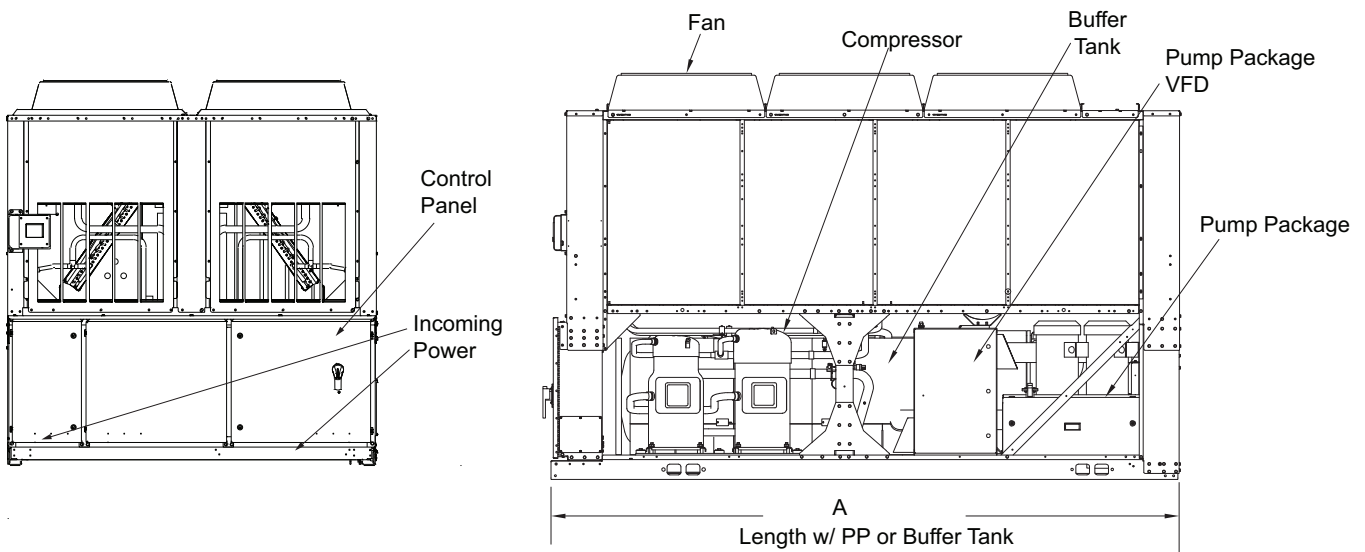
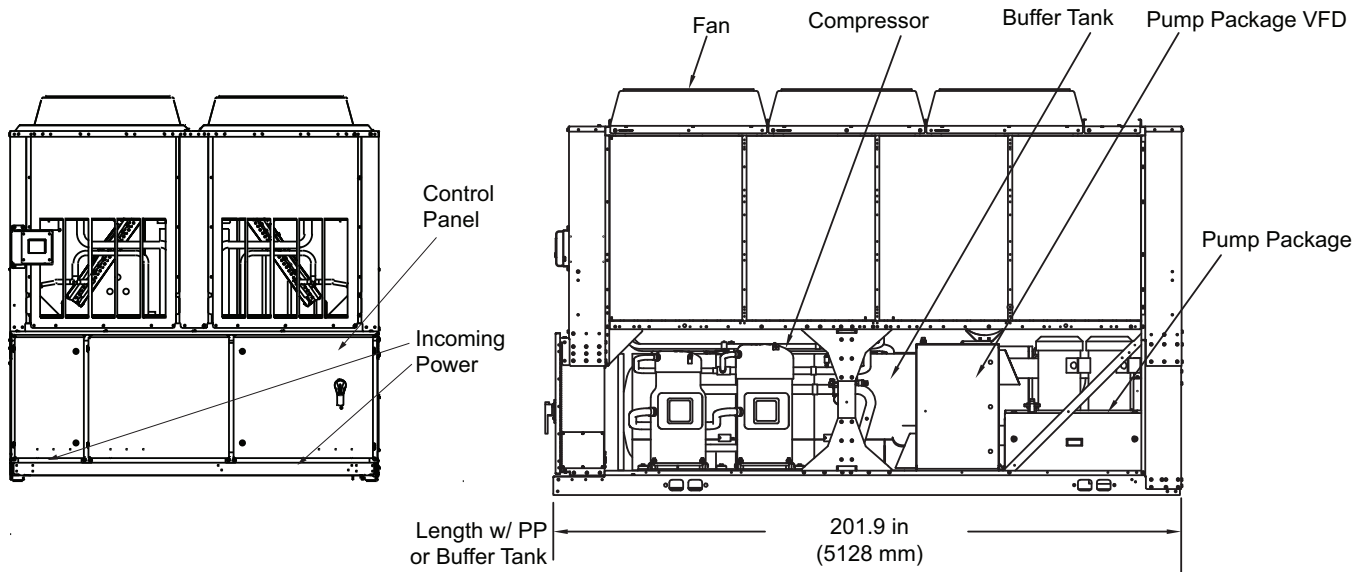

Table 8. Dimensions, 80 to 120 ton units with options

Unit Size (tons)	A	
	in.	mm
80, 90, 100	143.1	3634
110, 120	165.9	4214

Figure 14. CGAM 130 ton, with options



Water Connections

Figure 15. Water connection dimensions, 20 to 35 ton units with options

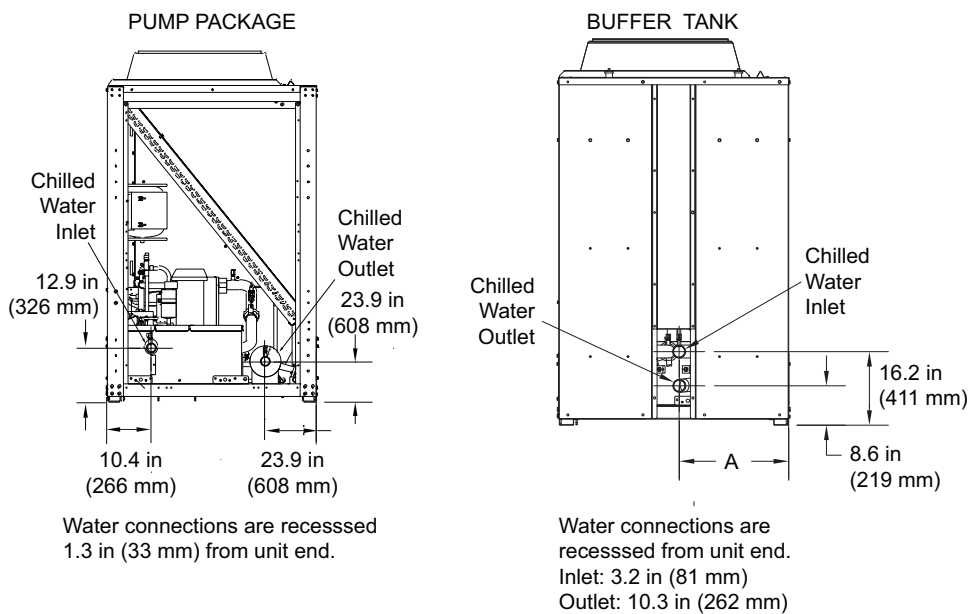

Dimensions

Table 9. Water connection dimensions, 20 to 35 ton units with options

Unit Size (tons)	A		B	
	in.	mm	in.	mm
20, 26	24.1	613	70.3	1784
30, 35	23.9	608	67.4	1712

Figure 16. Water connection dimensions, 40 to 70 ton units with options

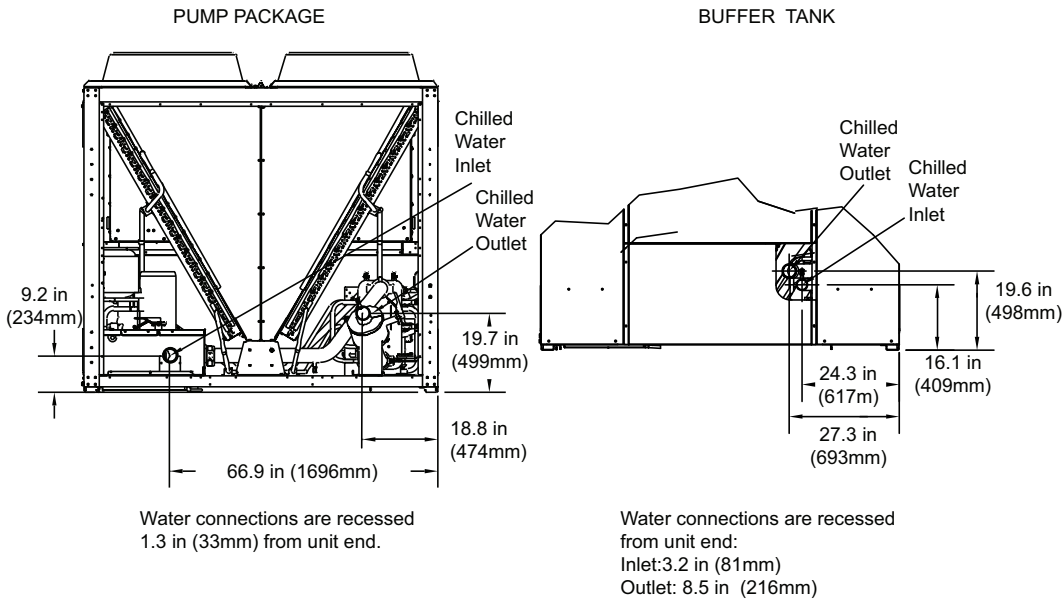

Table 10. Water connection dimensions, 40 to 70 ton units with options

Unit Size (tons)	A		B		C	
	in.	mm	in.	mm	in.	mm
40, 52	24.3	617	45.3	1149	54.8	1392
60, 70	24.2	615	45.6	1158	55.2	1401

Figure 17. Water connection dimensions, 80 to 130 ton units with options

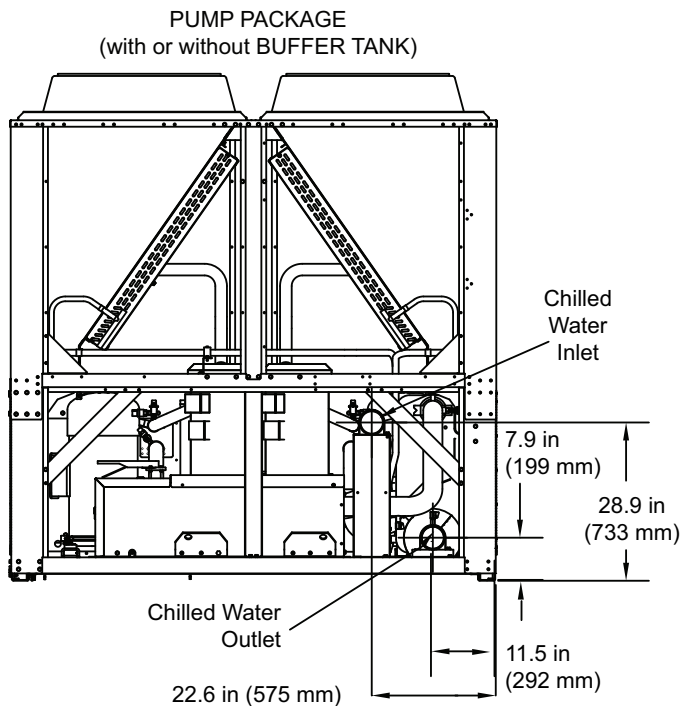

Table 11. Water connection dimensions, 80 to 130 ton units with options

Unit Size (tons)	Pump Package ^(a)				Buffer Tank			
	Inlet		Outlet		Inlet		Outlet	
	in.	mm	in.	mm	in.	mm	in.	mm
80, 90	5.9	151	5.9	151	6.2	158	6.2	158
100, 110, 120	5.9	151	5.9	151	6	153	6	153
130	6.3	159	25	635	5.9	150	27.7	703

^(a) Distance from end of unit.

Service Clearances

Figure 18. CGAM service clearances

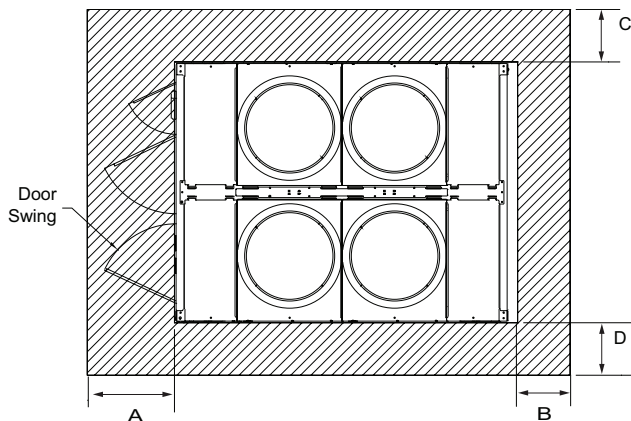

Unit Size (Tons)	A		B		C		D	
	in.	mm	in.	mm	in.	mm	in.	mm
20 to 35	47.2	1200	31.5	800	23.6	600	39.4	1000
40 to 70	47.2	1200	31.5	800	39.4	1000	39.4	1000
80 to 130	47.2	1200	39.4	1000	39.4	1000	39.4	1000

Notes:

- Number of fans and panel doors shown does not represent the number of fans installed.
- More clearance may be needed for airflow, depending on installation.

Mounting Locations

Note: All mounting holes are 0.75 in. (19 mm) in diameter.

Figure 19. Mounting locations, 20 to 35 tons

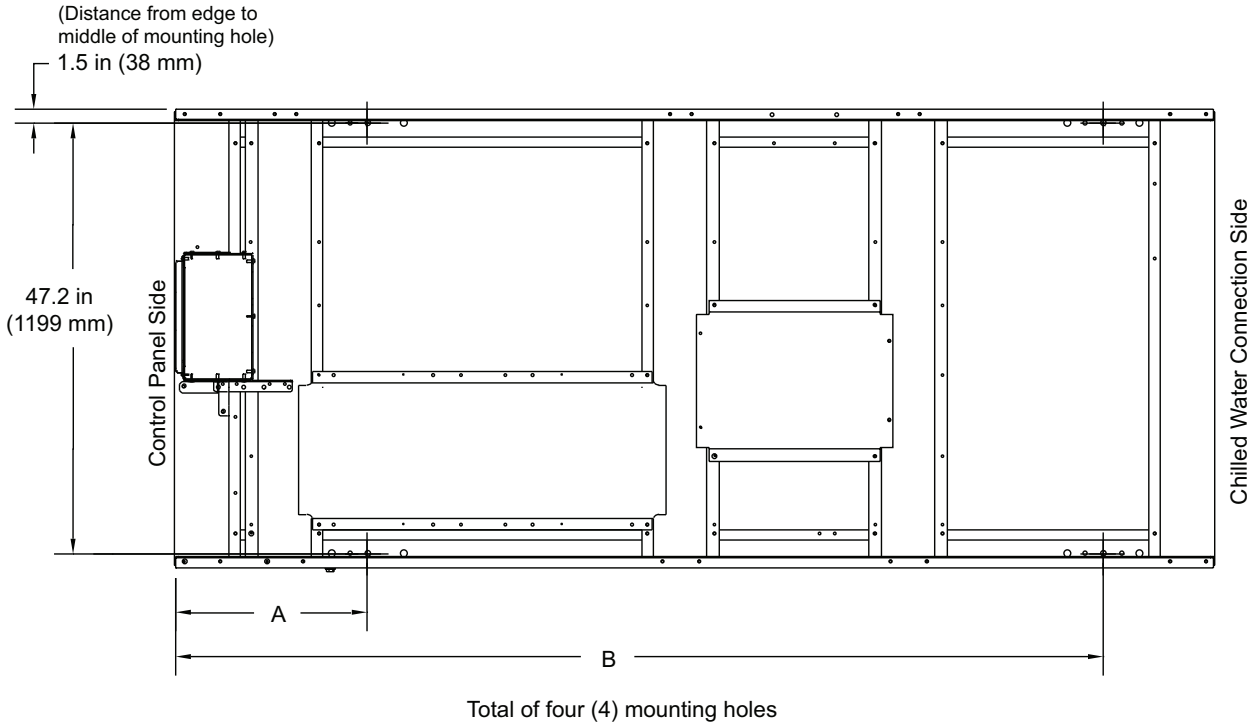
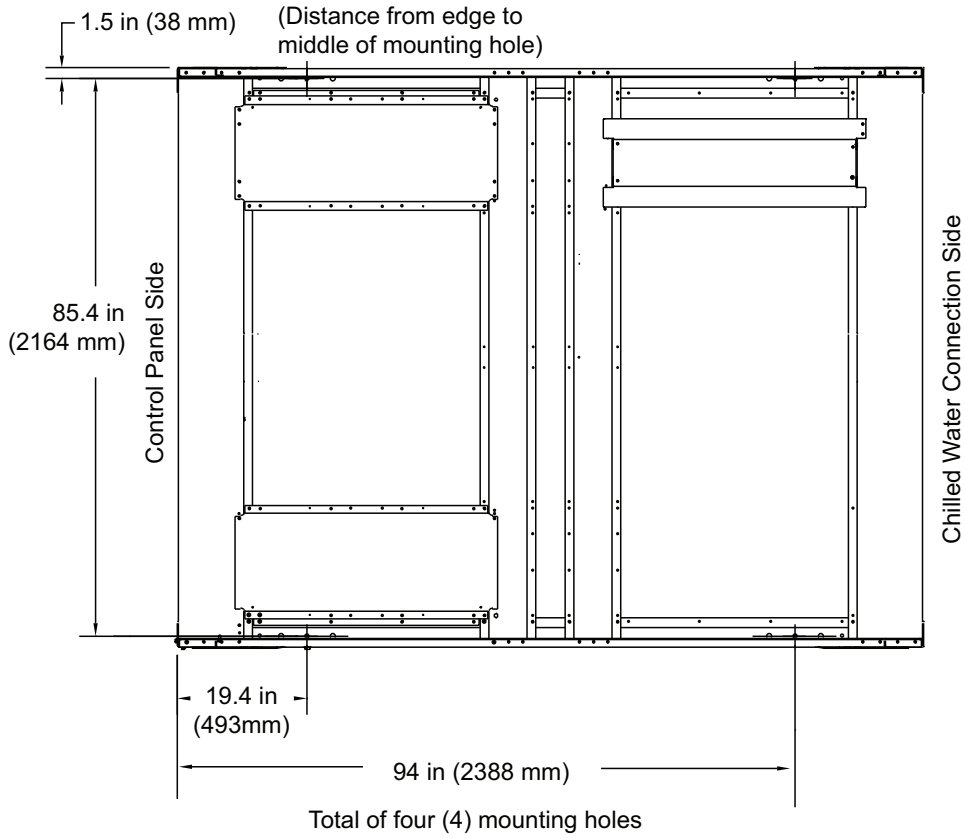

Table 12. Mounting locations, 20 to 35 ton units

Unit Size (tons)	A		B	
	in.	mm	in.	mm
20, 26	21	533	101.2	2570
30, 35	21.9	556	132.2	3358

Figure 20. Mounting locations, 40 and 52 tons





Dimensions

Figure 21. Mounting locations, 60 and 70 tons

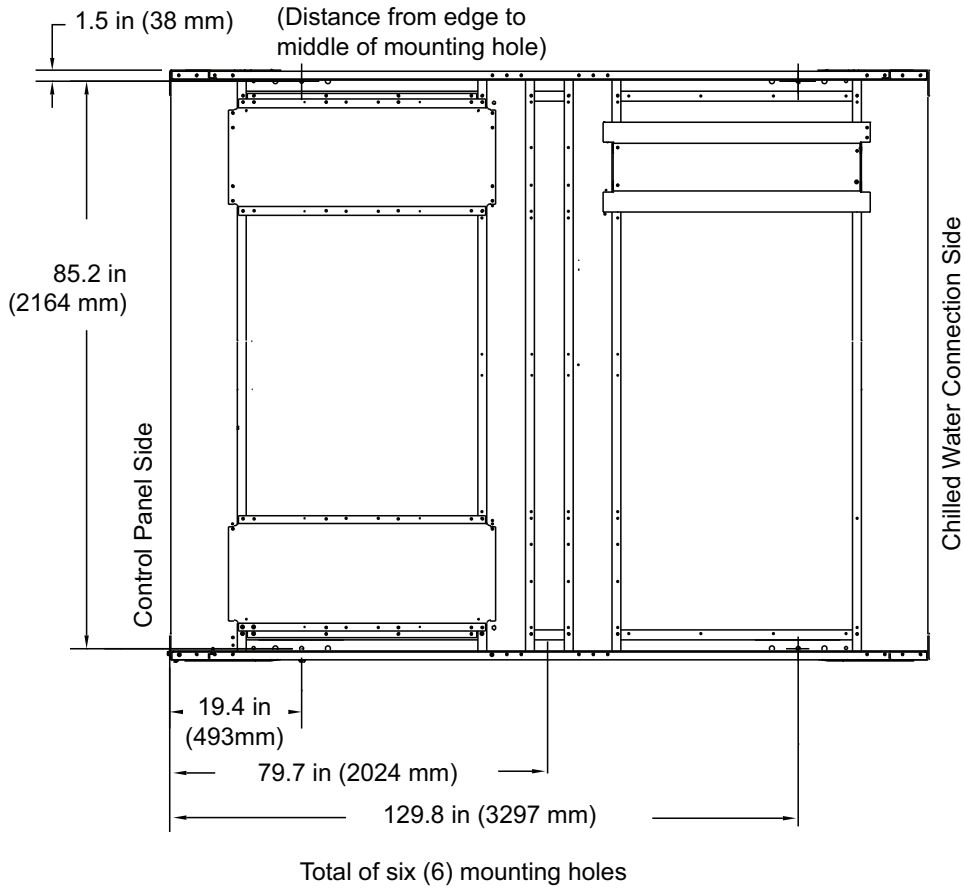
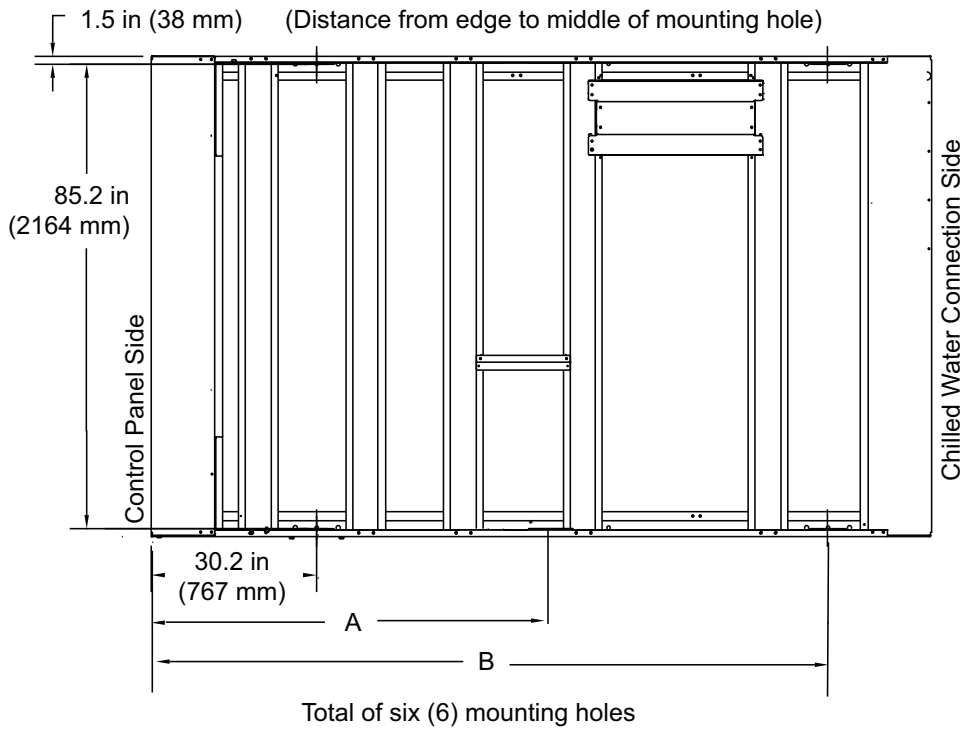

Figure 22. Mounting locations, 80 to 120 tons

Note: For seismic applications, neoprene pads need to be glued down on the mounting surface at the four corner locations of the unit.

Table 13. Mounting locations, 80 to 120 ton units

Unit Size (tons)	A		B	
	in.	mm	in.	mm
80, 90	83.7	2126	123.9	3147
100, 110, 120	89.2	2266	146.9	3731



Dimensions

Figure 23. Mounting locations, 130 tons

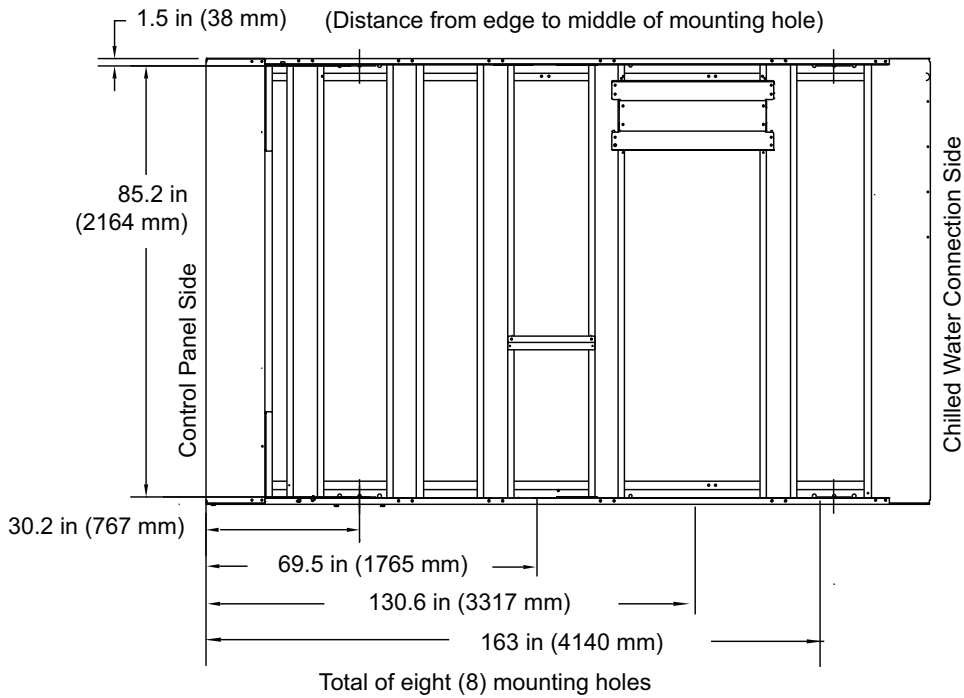

Note: For 130 ton units with seismic option, seismically rated isolator must be glued to the bottom of the unit at each of the four corners for installation.



Weights

Base Units

Note: Weights are applicable to units with seismic or wind load options.

Table 14. Base unit weights — I-P (lb)

Unit Size (Tons)	Base Unit		Base Unit with Pump Package		Base Unit with Pump Package and Buffer Tank	
	Shipping	Operating	Shipping	Operating	Shipping	Operating
20	2258	2281	2798	2887	3325	4564
26	2322	2351	2863	2964	3389	4634
30	2945	2979	3487	3596	4014	5262
35	3023	3065	3565	3691	4092	5349
40	3812	3843	4431	4529	5022	6262
52	3959	4004	4578	4705	5169	6423
60	5177	5232	6013	6184	6604	7893
70	5118	5194	5954	6166	6545	7855
80	5607	5692	6486	6790	7077	8561
90	5859	5961	6738	7075	7329	8830
100	6646	6759	7549	7909	8265	10136
110	6724	6846	7627	8005	8343	10223
120	6762	6884	8018	8396	8733	10614
130	7753	7900	9006	9430	9722	11623

Note: All weights $\pm 3\%$.

Table 15. Base unit weights — SI (kg)

Unit Size (Tons)	Base Unit		Base Unit with Pump Package		Base Unit with Pump Package and Buffer Tank	
	Shipping	Operating	Shipping	Operating	Shipping	Operating
20	1024	1035	1269	1310	1508	2070
26	1053	1066	1298	1344	1537	2102
30	1336	1351	1582	1631	1821	2387
35	1371	1390	1617	1674	1856	2426
40	1729	1743	2010	2054	2278	2840
52	1796	1816	2077	2134	2345	2914
60	2348	2373	2727	2805	2996	3580
70	2322	2356	2701	2797	2969	3563
80	2543	2582	2942	3080	3210	3883
90	2658	2704	3056	3209	3324	4005
100	3015	3066	3424	3587	3749	4598
110	3050	3105	3460	3631	3784	4637
120	3067	3122	3637	3808	3961	4814
130	3517	3583	4085	4277	4410	5272

Note: All weights $\pm 3\%$.



A2L Work Procedures

⚠ WARNING

Risk of Fire — Flammable Refrigerant!

Failure to follow instructions below could result in death or serious injury, and equipment damage.

- To be repaired only by trained service personnel.
- Do not puncture refrigerant tubing.
- Dispose of properly in accordance with federal or local regulations.

⚠ WARNING

Refrigerant under High Pressure!

Failure to follow instructions below could result in an explosion which could result in death or serious injury or equipment damage.

System contains refrigerant under high pressure. Recover refrigerant to relieve pressure before opening the system. See unit nameplate for refrigerant type. Do not use non-approved refrigerants, refrigerant substitutes, or refrigerant additives.

⚠ WARNING

Hazardous Voltage!

Failure to disconnect power before servicing could result in death or serious injury.

Disconnect all electric power, including remote disconnects before servicing. Follow proper lockout/tagout procedures to ensure the power can not be inadvertently energized. Verify that no power is present with a voltmeter.

The units described in this manual use R-454B refrigerant. Use ONLY R-454B rated service equipment or components with these units. For specific handling concerns with R-454B, contact your local Trane representative.

Installation, repair, removal, or disposal should be performed by trained service personnel.

At all times, Trane's maintenance and service guidelines shall be followed. If in doubt, contact Trane technical support for assistance.

Serviceing

Prior to initiating work on equipment, check the area with an appropriate refrigerant detector. Ensure the service personnel are properly trained regarding work in potentially toxic or flammable atmospheres. Ensure that the leak detection equipment being used is suitable for use with all applicable refrigerants, i.e. non-sparking, adequately

sealed, or intrinsically safe. Be aware that the refrigerant does not contain an odor.

If any hot work is to be conducted on the refrigerating equipment or any associated parts, appropriate fire extinguishing equipment shall be available on hand. A dry powder or CO₂ fire extinguisher should be located adjacent to the charging area.

At all times, Trane's maintenance and service guidelines shall be followed. If in doubt, contact Trane technical support for assistance.

All maintenance staff and others working in the local area shall be instructed on the nature of the work being carried out. Work in confined spaces shall be avoided.

Ignition Source Mitigation

Do not use any sources of ignition when working on the refrigeration system.

Keep all ignition sources, including cigarette smoking, away from the site of installation, repair, removal or disposal, during which refrigerant can potentially be released to the surrounding space.

Survey the area around the equipment before initiating work to ensure no flammable hazards or ignition risks are present.

"No Smoking" signs shall be displayed.

Do not use devices that can be a source of ignition to accelerate defrosting of components. Use only defrost and cleaning procedures recommended by Trane. Do not pierce or burn.

Ventilation

Ensure that the area is in the open or that it is adequately ventilated before breaking into the system or conducting any hot work. A degree of ventilation shall continue during the period that the work is carried out. The ventilation should safely disperse any released refrigerant and preferably expel it externally into the atmosphere. If present, check that the ventilation system, including outlets, are operating adequately and are not obstructed.

Refrigerating Equipment

Refrigerant piping or components should not be installed in locations where substances which may corrode them are present.

Check that equipment hazard markings are visible and legible. Replace them if they are not.

For equipment using secondary fluids, like water or glycol, check that refrigerant is not present in the secondary fluid loop before conducting any hot work.

Electrical Devices

Do not apply power to the circuit if a fault exists which compromises safety. If the fault cannot be corrected

immediately, but it is necessary to continue operation, an adequate temporary solution shall be used. This shall be reported to the owner of the equipment, so all parties are advised.

Initial safety checks shall include:

- Cabling is not subject to wear, corrosion, excessive pressure, vibration, sharp edges, or any other adverse environmental effects. Account for the effects of aging or continual vibration from sources such as compressors or fans.
- Capacitors are discharged. This shall be done in a safe manner to avoid possibility of sparking.
- No live electrical components and wiring are exposed while charging, recovering, or purging the system.
- Verify continuity of earth bonding.
- Replace electrical components with Trane replacement parts, or those meeting the same ratings and qualified for flame arrest protection, UL LZGH2 category.

Leak Detection

Never use an open flame to detect leaks. A halide torch should not be used. Use only approved leak detection methods per this instruction manual.

The following leak detection methods are deemed acceptable for all refrigerant systems.

Electronic leak detectors may be used to detect refrigerant leaks but, in the case of flammable refrigerants, the sensitivity may not be adequate, or may need re-calibration. (Detection equipment shall be calibrated in a refrigerant-free area.) Ensure that the detector is not a potential source of ignition and is suitable for the refrigerant used. Leak detection equipment shall be set at a percentage of the LFL gas (25% maximum) is confirmed.

Leak detection fluids are also suitable for use with most refrigerants but the use of detergents containing chlorine shall be avoided as the chlorine may react with the refrigerant and corrode the copper pipe-work.

Examples of leak detection fluids are:

- Bubble method
- Fluorescent method agents

If a leak is suspected, all naked flames shall be removed/ extinguished.

If a refrigerant leak is found which requires brazing, all refrigerant shall be recovered from the system, or isolated (by means of shut off valves) in a part of the system remote from the leak.

Refrigerant Removal and Evacuation

Ensure that the correct number of cylinders for holding the total system charge is available. All cylinders to be used are designated for the recovered refrigerant and labeled for

that refrigerant (special cylinders for the recovery of refrigerant, for example). Cylinders shall be complete with pressure-relief valve and associated shut-off valves in good working order. Empty recovery cylinders are evacuated and, if possible, cooled before recovery occurs.

When breaking into the refrigerant circuit to make repairs – or for any other purpose – conventional procedures shall be used. However, for flammable refrigerants it is important that best practice be followed, since flammability is a consideration.

The following procedure shall be adhered to:

1. Safely remove refrigerant following local and national regulations.
2. Evacuate.
3. Purge the circuit with inert gas.
4. Evacuate (optional for A2L).
5. Continuously flush or purge with inert gas when using flame to open circuit.
6. Open the circuit.

Prior to refrigerant removal, open all appropriate valves, including solenoid and electronic expansion valves (EXVs). Use control settings, where available. When not available, manually open all electronically controlled valves using acceptable service procedures.

The recovery equipment shall be in good working order with instructions available. Equipment shall be suitable for the recovery of the flammable refrigerant. For specific handling concerns, contact the manufacturer. Ensure all hose connections are checked for tightness to avoid refrigerant leaks.

The refrigerant shall be recovered into the correct recovery cylinders if venting is not allowed by local and national codes. Do not mix refrigerants in recovery unit and especially not in cylinders.

Refrigerant recovery unit should be purged with an inert gas after each use or before using with a different refrigerant Class – for example, A2L to A1.

If compressors or compressor oils are to be removed, ensure that they have been evacuated to an acceptable level to make certain that flammable refrigerant does not remain within the lubricant. The compressor body shall not be heated by an open flame or other ignition sources to accelerate this process. When oil is drained from a system, it shall be carried out safely.

The system shall be purged with oxygen-free nitrogen to render the appliance safe for flammable refrigerants. This process might need to be repeated several times. Compressed air or oxygen shall not be used for purging refrigerant systems.

The system shall be vented down to atmospheric pressure to enable work to take place.

The outlet for the vacuum pump shall not be close to any potential ignition sources, and ventilation shall be available.

Refrigerant Charging

In addition to conventional charging procedures, the following requirements shall be followed.

- Ensure that contamination of different refrigerants does not occur when using charging equipment.
- Hoses or lines shall be as short as possible to minimize the amount of refrigerant contained in them.
- Cylinders shall be kept in an appropriate position according to the instructions.
- Ensure that the refrigerating system is earthed prior to charging the system with refrigerant.
- Label the system when charging is complete (if not already).
- Extreme care shall be taken not to overfill the refrigerating system.

Prior to recharging the system, it shall be pressure-tested with the appropriate purging gas. The system shall be leak-tested on completion of charging but prior to commissioning. A follow up leak test shall be carried out prior to leaving the site.

Prior to refrigerant charging, open all appropriate valves, including solenoid and electronic expansion valves (EXVs). Use control settings, where available. When not available, manually open all electronically controlled valves using acceptable service procedures.

Decommissioning

Before carrying out the decommissioning procedure, it is essential that the trained service personnel is completely familiar with the equipment and all its details. It is recommended good practice that all refrigerants are recovered safely. Prior to the task being carried out, an oil and refrigerant sample shall be taken in case analysis is required prior to re-use of recovered refrigerant. It is essential that electrical power is available before the task is commenced.

1. Become familiar with the equipment and its operation.
2. Isolate system electrically.
3. Before attempting the procedure, ensure that:
 - a. Mechanical handling equipment is available, if required, for handling refrigerant cylinders.
 - b. All personal protective equipment is available and being used correctly.
 - c. The recovery process is supervised at all times by a competent person.
 - d. Recovery equipment and cylinders conform to the appropriate standards.
4. Pump down refrigerant system, if possible.
5. If a vacuum is not possible, make a manifold so that refrigerant can be removed from various parts of the system.
6. Make sure that cylinder is situated on the scales before recovery takes place.
7. Start the recovery machine and operate in accordance with instructions.
8. Do not overfill cylinders (no more than 80% volume liquid charge).
9. Do not exceed the maximum working pressure of the cylinder, even temporarily.
10. When the cylinders have been filled correctly and the process completed, make sure that the cylinders and the equipment are removed from site promptly and all isolation valves on the equipment are closed off.
11. Recovered refrigerant shall not be charged into another refrigerating system unless it has been cleaned and checked.
12. When equipment has been decommissioned, attach a signed label which includes the date of decommissioning.



Installation - Mechanical

Location Requirements

Sound Considerations

- Refer to *Chiller Sound Ratings and Installation Guide Engineering Bulletin* (CG-PRB010*-EN) for sound consideration applications.
- Locate the unit away from sound-sensitive areas.
- Install the optional elastomeric isolators under the unit. See “[Unit Isolation and Leveling](#),” p. 34.
- Chilled water piping should not be supported by chiller frame.
- Install rubber vibration isolators in all water piping.
- Seal all wall penetrations.

Note: Consult an acoustical engineer for critical applications.

Foundation

Provide rigid, non-warping mounting pads or a concrete foundation of sufficient strength and mass to support the applicable operating weight (i.e. including completed piping, and full operating charges of refrigerant, oil and water). The expectation for our equipment is that attached piping is fully supported by an independent structure/system, without being connected to the braze plate heat exchanger. Once in place, the unit must be level within 1/2 inch (12.7 mm) across the length and width of the unit. Trane is not responsible for equipment problems resulting from an improperly designed or constructed foundation.

Clearances

Provide enough space around the unit to allow the installation and maintenance personnel unrestricted access to all service points. Refer to submittal drawings for the unit dimensions, to provide sufficient clearance for the opening of control panel doors and unit service. See “[Service Clearances](#),” p. 23 for minimum clearances. In all cases, local codes which require additional clearances will take precedence over these recommendations.

Rigging

See “[Weights](#),” p. 29 for typical unit lifting weights. Refer to the rigging label attached to the unit for further details.

Lifting Procedure

⚠ WARNING

Heavy Object!

Failure to follow instructions below could result in unit dropping which could result in death or serious injury, and equipment or property-only damage. Ensure that all the lifting equipment used is properly rated for the weight of the unit being lifted. Each of the cables (chains or slings), hooks, and shackles used to lift the unit must be capable of supporting the entire weight of the unit. Lifting cables (chains or slings) may not be of the same length. Adjust as necessary for even unit lift.

⚠ WARNING

Improper Unit Lift!

Failure to properly lift unit in a LEVEL position could result in unit dropping and possibly crushing operator/technician which could result in death or serious injury, and equipment or property-only damage. Test lift unit approximately 24 inches (61 cm) to verify proper center of gravity lift point. To avoid dropping of unit, reposition lifting point if unit is not level.

NOTICE

Equipment Damage!

To prevent damage to unit, do not fork lift or allow lifting cables to contact unit during lift.

Lifting using either a single spreader bar or an H-type spreader is acceptable. Attach chains or cables to lifting beam. Lifting beam crossbars **MUST** be positioned so lifting cables do not contact the sides of the unit.

Important: The center of gravity (CG) is never at the midpoint of the base rail lifting strap holes. A level unit lift is required for a safe lift and to prevent unit damage.

Lifting a unit with equal length straps will NOT produce a level unit during the lift because the CG will not be at the midpoint between the base lifting holes. The following adjustments must be made to produce a level lift:

- Single spreader bar lifting method
 - If the unit CG is closer to the control panel, the straps on the control panel side of the spreader bar must be adjusted to be shorter than those on the opposite side of the spreader bar, allowing the spreader bar to move toward the control panel and over the unit CG. Several adjustments of the strap length may be required to produce a level unit during lift.
- H-type spreader bar lifting method

- If the straps from the H bar to the unit base are the same length, the crane lifting point on the center web of the H bar must be adjusted to produce a level unit lift. See following figure for illustration.

Figure 24. H-type spreader bar adjustment for level unit lift

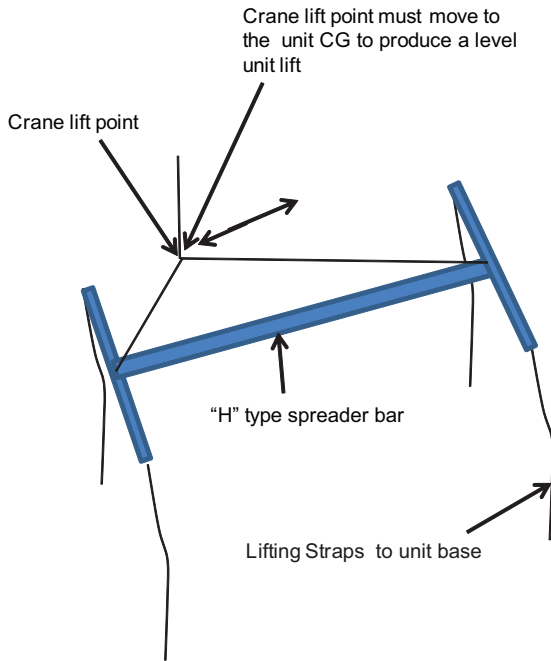

Figure 25. CGAM slant 20 to 35 ton unit rigging

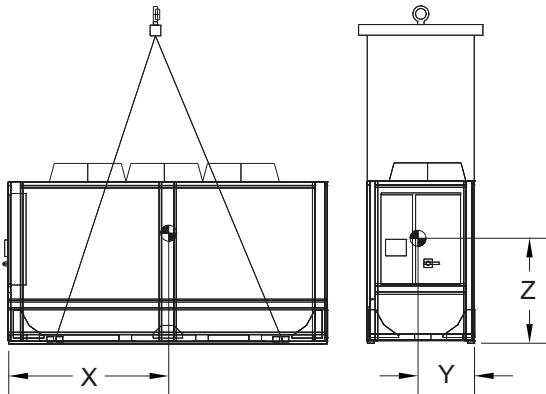

Figure 26. CGAM V 40 to 70 ton unit rigging

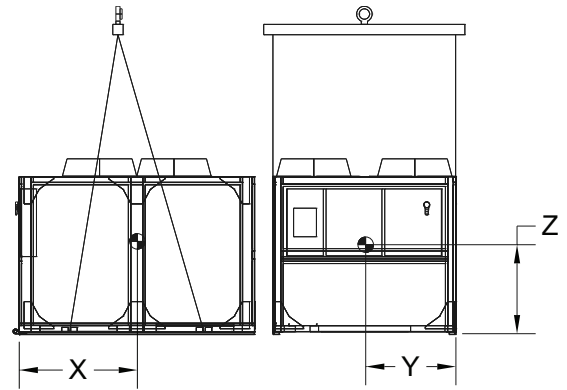
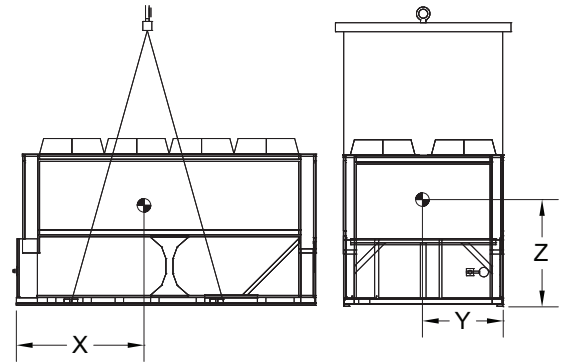

Figure 27. CGAM W 80 to 130 ton unit rigging



Unit Isolation and Leveling

General

Construct an isolated concrete pad for the unit or provide concrete footings at each of the unit mounting points. Mount the unit directly to the concrete pads or footings.

Level the unit using the base rail as a reference. The unit must be level within 1/4 inch over the entire length (end-to-end as well as side-to-side). Use shims as necessary to level the unit.

Isolator Options

Elastomeric Isolators

1. Install the optional neoprene isolators at each mounting location. Isolators are identified by part number and color.
2. Secure the isolators to the mounting surface, using the mounting slots in the isolator base plate, as shown in [Figure 28, p. 35](#). Do not fully tighten the isolator mounting bolts at this time.
3. Align the mounting holes in the base of the unit, with the threaded positioning pins on the top of isolators.
4. Lower the unit on to the isolators and secure the isolator to the unit with a nut. Level the unit carefully. Refer to [“Unit Isolation and Leveling,” p. 34](#). Fully tighten the isolator mounting bolts.

Figure 28. CGAM elastomeric isolator

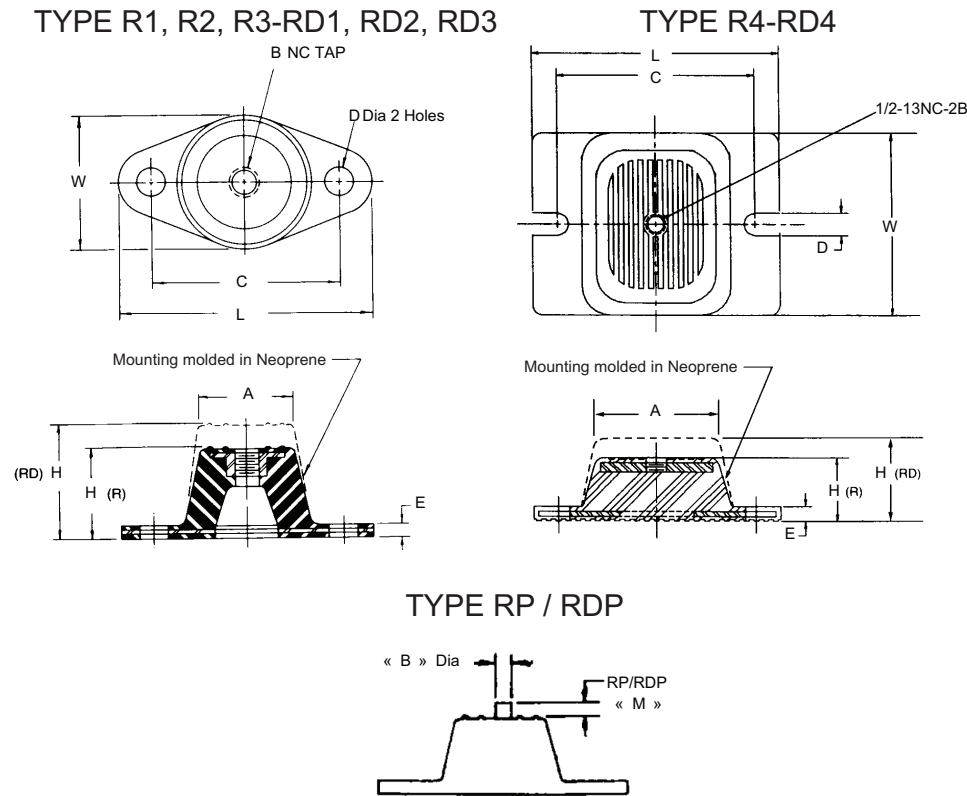

Table 16. CGAM elastomeric rated isolator

Ext	Max Load (lbs)		Color		Maximum Deflection (in)			Type	
57	250		Black		0.50			RDP3-WR	
58	525		Red						
59	750		Green						
60	1100		Gray						
61	1500		Brown		0.50			RDP4-WR	
62	2250		Red						
63	3000		Green						
64	4000		Gray						
Ext	A	B	C	D	E	H	L	M	W
57	2.5	0.5	4.12	0.56	0.25	2.88	5.5	1.13	3.38
58									
59									
60									
61	3.0	0.5	5.0	0.56	0.38	2.75	6.25	1.60±0.25	4.63
62									
63									
64									

Elastomeric Pads

Elastomeric pads are required for units with wind load rating option (model number digit 17 = D).

Elastomeric pads ship inside the unit control panel. They are provided with an isolation washer and 3/4" free hole in the center of the plate.

Figure 29. Isolation pad — installed

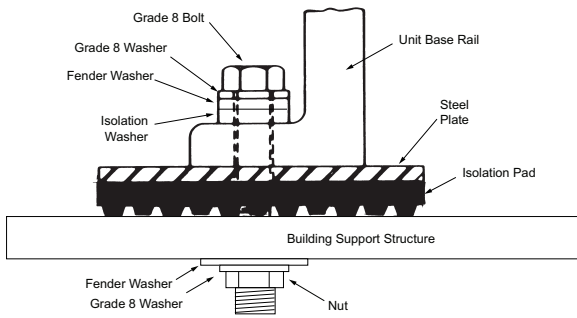

(Washers under support structure recommended if job site has an I-beam or C-channel.)

Table 17. Seismically rated elastomeric isolation pad

Model	Max Load	Dimension (in.)		
		Length	Width	Height
B-36	2520	6	6	625

Isolator Selection and Placement

Isolator Selection

Non-Seismic Units

Table 18. Elastomeric isolator selections — base unit (with or without partial heat recovery)

Unit Size (tons)	Location							
	1	2	3	4	5	6	7	8
20, 26	RDP-3 Grey 60	RDP-3 Grey 60	RDP-3 Grey 60	RDP-3 Grey 60	-	-	-	-
30, 35	RDP-4 Brown 61	RDP-4 Brown 61	RDP-3 Grey 60	RDP-3 Grey 60	-	-	-	-
40, 52	RDP-4 Red 62	RDP-4 Red 62	RDP-4 Red 62	RDP-4 Red 62	-	-	-	-
60, 70	RDP-4 Red 62	RDP-4 Red 62	RDP-3 Gray 60	RDP-4 Brown 61	RDP-3 Gray 60	RDP-3 Gray 60	-	-
80 to 90	RDP-4 Green 63	RDP-4 Green 63	RDP-4 Red 62	RDP-4 Red 62	RDP-3 Gray 60	RDP-3 Gray 60	-	-
100 to 120	RDP-4 Red 62	RDP-4 Green 63	RDP-4 Red 62	RDP-4 Red 62	RDP-3 Gray 60	RDP-3 Brown 61	-	-
130	RDP-4 Red 62	RDP-4 Red 62	RDP-4 Red 62	RDP-4 Red 62	RDP-4 Red 62	RDP-4 Red 62	RDP-3 Brown 61	RDP-3 Grey 60

Table 19. Elastomeric isolator selections — with pump package (with or without partial heat recovery)

Unit Size (tons)	Location							
	1	2	3	4	5	6	7	8
20, 26	RDP-4 Grey 60	RDP-3 Grey 60	RDP-3 Grey 60	RDP-3 Grey 60	-	-	-	-
30, 35	RDP-4 Brown 61	RDP-4 Brown 61	RDP-4 Brown 61	RDP-4 Brown 61	-	-	-	-
40, 52	RDP-4 Red 62	RDP-4 Red 62	RDP-4 Red 62	RDP-4 Red 62	-	-	-	-
60, 70	RDP-4 Red 62	RDP-4 Red 62	RDP-4 Red 62	RDP-4 Red 62	RDP-4 Red 62	RDP-4 Red 62	-	-
80 to 90	RDP-4 Red 62	RDP-4 Green 63	RDP-4 Red 62	RDP-4 Red 62	RDP-3 Red 62	RDP-3 Red 62	-	-

Table 19. Elastomeric isolator selections — with pump package (with or without partial heat recovery) (continued)

Unit Size (tons)	Location							
	1	2	3	4	5	6	7	8
100 to 120	RDP-4 Green 63	RDP-4 Green 63	RDP-4 Green 63	RDP-4 Green 63	RDP-4 Green 63	RDP-4 Green 63	-	-
130	RDP-4 Red 62	RDP-4 Red 62	RDP-4 Red 62	RDP-4 Red 62	RDP-4 Red 62	RDP-4 Red 62	RDP-4 Red 62	RDP-4 Red 62

Table 20. Elastomeric isolator selections — with pump package and buffer tank option (with or without partial heat recovery)

Unit Size (tons)	Location							
	1	2	3	4	5	6	7	8
20, 26	RDP-3 Grey 60	RDP-3 Grey 60	RDP-4 Green 63	RDP-4 Green 63	-	-	-	-
30, 35	RDP-3 Grey 60	RDP-3 Grey 60	RDP-4 Green 63	RDP-4 Green 63	-	-	-	-
40, 52	RDP-4 Brown 61	RDP-4 Brown 61	RDP-4 Grey 64	RDP-4 Grey 64	-	-	-	-
60, 70	RDP-4 Brown 61	RDP-4 Brown 61	RDP-4 Green 63	RDP-4 Green 63	RDP-4 Green 63	RDP-4 Green 63	-	-
80 to 90	RDP-4 Green 63	RDP-4 Green 63	RDP-4 Red 62	RDP-4 Red 62	RDP-4 Red 62	RDP-4 Red 62	-	-
100 to 120	RDP-4 Grey 64	RDP-4 Grey 64	RDP-4 Green 63	RDP-4 Green 63	RDP-4 Green 63	RDP-4 Green 63	-	-
130	RDP-4 Green 63	RDP-4 Green 63	RDP-4 Green 63	RDP-4 Green 63	RDP-4 Green 63	RDP-4 Green 63	RDP-4 Green 63	RDP-4 Green 63

Mounting Point Weights

Units with Round Tube, Plate Fin (RTPF) Condensers

Table 21. Point weights (lbs) — RTPF condensers, 60 Hz, high efficiency— base unit

Unit Size (tons)	Isolator Location							
	1	2	3	4	5	6	7	8
Units without Partial Heat Recovery								
20	724	663	426	383	-	-	-	-
26	810	632	387	439	-	-	-	-
30	800	830	620	456	-	-	-	-
35	919	886	669	460	-	-	-	-
40	1188	1073	647	848	-	-	-	-
52	1117	1192	750	805	-	-	-	-
60	1005	1137	663	795	635	525	-	-
70	1150	1243	814	882	544	591	-	-
80	1435	1662	774	885	396	449	-	-
90	1507	1763	802	927	406	466	-	-
100	1640	1587	847	1120	608	866	-	-
110	1673	1634	850	1134	602	863	-	-
120	1690	1651	853	1138	600	861	-	-
130	1284	1272	910	1229	861	852	569	826
Units with Partial Heat Recovery								



Installation - Mechanical

Table 21. Point weights (lbs) — RTPF condensers, 60 Hz, high efficiency— base unit (continued)

Unit Size (tons)	Isolator Location							
	1	2	3	4	5	6	7	8
20	726	679	433	400	-	-	-	-
26	811	648	393	456	-	-	-	-
30	861	798	569	527	-	-	-	-
35	980	854	618	532	-	-	-	-
40	1098	1147	785	821	-	-	-	-
52	1110	1184	806	861	-	-	-	-
60	965	1022	860	917	537	576	-	-
70	1131	1223	845	913	591	637	-	-
80	1528	1756	780	891	384	437	-	-
90	1602	1858	807	932	394	454	-	-
100	1732	1680	860	1138	596	848	-	-
110	1765	1726	864	1152	589	845	-	-
120	1783	1744	867	1156	587	843	-	-
130	1129	1587	1144	1072	855	803	589	812

Table 22. Point weights (lbs) — RTPF condensers, 60 Hz, high efficiency — with pump package (no buffer tank)

Unit Size (tons)	Isolator Location							
	1	2	3	4	5	6	7	8
Units without Partial Heat Recovery								
20	893	630	621	637	-	-	-	-
26	928	649	632	642	-	-	-	-
30	856	860	929	644	-	-	-	-
35	971	921	983	644	-	-	-	-
40	1250	1145	1046	969	-	-	-	-
52	1262	1182	1066	1008	-	-	-	-
60	1237	976	835	895	767	827	-	-
70	1294	1259	899	874	851	825	-	-
80	1296	1663	922	1070	901	763	-	-
90	1556	1616	816	1152	857	886	-	-
100	1278	1684	1330	1175	1013	1226	-	-
110	1305	1733	1339	1189	1006	1221	-	-
120	1276	1623	1280	1629	1284	1091	-	-
130	835	1195	1150	1206	1167	1223	1177	1233
Units with Partial Heat Recovery								
20	895	644	627	655	-	-	-	-
26	870	724	699	599	-	-	-	-
30	862	884	934	660	-	-	-	-
35	1050	871	913	734	-	-	-	-
40	1154	1227	1190	936	-	-	-	-
52	1164	1265	1213	974	-	-	-	-
60	1219	962	857	916	819	878	-	-
70	1278	1242	922	896	902	876	-	-

Table 22. Point weights (lbs) — RTPF condensers, 60 Hz, high efficiency — with pump package (no buffer tank) (continued)

Unit Size (tons)	Isolator Location							
	1	2	3	4	5	6	7	8
80	1569	1609	804	1123	832	851	-	-
90	1648	1707	826	1166	842	870	-	-
100	1584	1635	1178	1212	951	1331	-	-
110	1616	1680	1183	1226	943	1329	-	-
120	1586	1561	1136	1679	1212	1196	-	-
130	1066	1198	1089	1221	1124	1256	1143	1275

Table 23. Point weights (lbs) — RTPF condensers, 60 Hz, high efficiency — with pump package and buffer tank

Unit Size (tons)	Isolator Location							
	1	2	3	4	5	6	7	8
Units without Partial Heat Recovery								
20	635	432	1746	1668	-	-	-	-
26	668	453	1759	1671	-	-	-	-
30	688	610	1964	1728	-	-	-	-
35	893	580	1927	1818	-	-	-	-
40	874	827	2302	2172	-	-	-	-
52	892	857	2315	2218	-	-	-	-
60	712	689	1270	1224	1737	1669	-	-
70	909	890	1217	1192	1798	1760	-	-
80	1868	2086	1234	1379	898	1005	-	-
90	1873	2145	1281	1657	957	828	-	-
100	1681	2251	1788	1796	1262	1267	-	-
110	1710	2298	1797	1810	1254	1263	-	-
120	1861	2235	1856	1671	1234	1666	-	-
130	1209	1222	1148	1741	1579	1599	1504	1523
Units with Partial Heat Recovery								
20	642	441	1747	1690	-	-	-	-
26	604	534	1831	1622	-	-	-	-
30	699	628	1963	1749	-	-	-	-
35	905	597	1925	1841	-	-	-	-
40	867	819	2358	2227	-	-	-	-
52	885	849	2372	2274	-	-	-	-
60	701	678	1281	1235	1795	1726	-	-
70	897	878	1231	1205	1855	1816	-	-
80	1823	2357	1284	1248	980	953	-	-
90	1959	2242	1296	1666	944	809	-	-
100	1762	2347	1816	1814	1246	1245	-	-
110	1791	2394	1825	1829	1238	1241	-	-
120	1941	2333	1885	1694	1220	1639	-	-
130	1157	1611	1132	1573	1638	1513	1607	1482

Evaporator Piping

Evaporator water connections are grooved.

Thoroughly flush all water piping to the CGAM unit before making the final piping connections to the unit.

Components and layout will vary slightly, depending on the location of connections and the water source.

NOTICE

Pump Damage!

Failure to follow instruction could result in pump damage.

If using any commercial flushing/cleaning solution, construct a temporary bypass around the unit to prevent damage to internal components of the evaporator/condenser. Trane assumes no responsibility for equipment damage caused by flushing/cleaning solutions or water-borne debris.

NOTICE

Proper Water Treatment Required!

The use of untreated or improperly treated water could result in scaling, erosion, corrosion, algae or slime.

Use the services of a qualified water treatment specialist to determine what water treatment, if any, is required. Trane assumes no responsibility for equipment failures which result from untreated or improperly treated water, or saline or brackish water.

Drainage

Locate the unit near a large capacity drain for water vessel drain-down during shutdown or repair. Drain connections are provided in the chilled water outlet line of evaporator. All local and national codes apply.

A vent is provided on the chilled water inlet line to the evaporator. Additional vents at high points in the piping must be provided to bleed air from the chilled water system. Install necessary pressure gauges to monitor the entering and leaving chilled water pressures.

Provide shutoff valves in lines to the gauges to isolate them from the system when they are not in use. Use rubber vibration eliminators to prevent vibration transmission through the water lines.

If desired, install thermometers in the lines to monitor entering and leaving water temperatures. Install a balancing valve in the leaving water line to control water flow balance. Install shutoff valves on both the entering and leaving water lines so that the evaporator can be isolated for service.

Evaporator Piping Components

Piping components include all devices and controls used to provide proper water system operation and unit operating safety. See Figure 30, p. 40. These components are listed below.

Figure 30. Water piping components

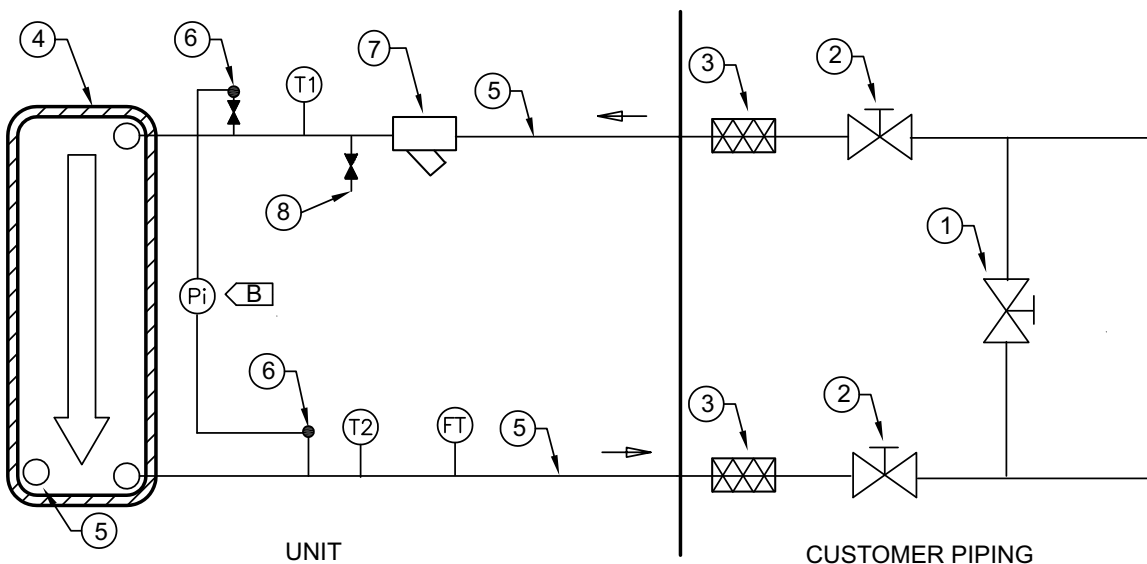

Table 24. Water piping components

Item	Description	Item	Description
1	Bypass Valve	Pi	Gauge
2	Isolation Valves	FT	Water Flow Switch
3	Vibration Eliminators	T1	Evap Water Inlet Temp Sensor
4	Evaporator Heat Exchanger	T2	Evap Water Outlet Temp Sensor
5	Water Heaters	B	Brazed plate differential pressure gauge and piping not supplied. Must account for water head height difference when calculating brazed plate pressure differential.
6	Valve for Pressure Point		
7	Strainer		
8	Water Heater (slant 20-35T units only)		

Entering Chilled Water Piping

- Air vents (to bleed air from system)
- Water pressure gauges with shutoff valves
- Vibration eliminators
- Shutoff (isolation) valves
- Thermometers (if desired)
- Relief valve

Leaving Chilled Water Piping

- Air vents (to bleed air from system)
- Water pressure gauges with shutoff valves
- Vibration eliminators
- Shutoff (isolation) valves
- Thermometers (if desired)
- Balancing valve

NOTICE

Water Damage!

Failure to follow instructions could result in water spray which could cause equipment and/or property damage.

Drain the system prior to releasing the pressure.

Standard pressure is 72.5 Psig for all factory installed components on the suction side of water pump. Standard pressure of components on the discharge side of water pump is 145 Psig. You **MUST** drain the system **FIRST** before releasing the pressure.

Water Strainer

The water strainer is factory-installed with taps for the pressure gauges on the inlet and outlet. Install pressure gauges in order to measure differential pressure across the filter. This will help to determine when it is necessary to clean the water strainer.

Flow Switch

NOTICE

Flow Switch Damage!

Incorrect voltage application could cause damage to the flow switch.

Flow switch is on a 24V circuit. Do NOT apply 120V to the flow switch.

The flow switch is factory-installed and programmed based on the operating conditions submitted with the order. The leaving evaporator temperature, fluid type and fluid concentration affect the selected flow switch. If the operating conditions on the job site change, the flow switch may need to be replaced.

The sensor head includes 3 LEDs, two yellow and one green. Wait 15 seconds after power is applied to the sensor before evaluating LEDs for flow status. When wired correctly and flow is established, only the green LED should be lit. Following are the LED indicators:

- Green ON, both yellow OFF — Flow
- Green and outside yellow ON — No Flow
- Center yellow ON continuously — Miswire

Factory installed jumper wire W9 must be removed if using auxiliary contacts and/or additional proof of flow. See schematics in *Air-Cooled Scroll Chillers Model CGAM 20 to 130 Tons, Wiring Manual* (CGAM-SVE01*-EN) for more details.

Note: Use caution when connecting the auxiliary contacts. Terminals 1X5-3 and 1X5-9 are to be used for field connections of auxiliary contacts. Inadvertent use of 1X5-4 and 1X5-9 will result in a FALSE FLOW indication.

NOTICE

Equipment Damage!

Incorrect wiring of auxiliary contacts could cause equipment damage.

See schematics for proper wiring.

If using auxiliary flow sensing, both yellow LEDs come on initially when flow is stopped. The center yellow LED will turn off after approximately 7 seconds. The LED indicators are otherwise the same as indicated above.

Indexing Flow Switch

To properly index the flow switch, the following requirements must be met:

- The dot/dimple must be at a position no greater than 90° off Index.
- The torque must be between 22 ft-lb minimum and 74 ft-lb maximum.
- A minimum distance of 5x pipe diameter must be maintained between flow switch and any bends, valves, changes in cross sections, etc.

Figure 31. Proper flow switch indexing

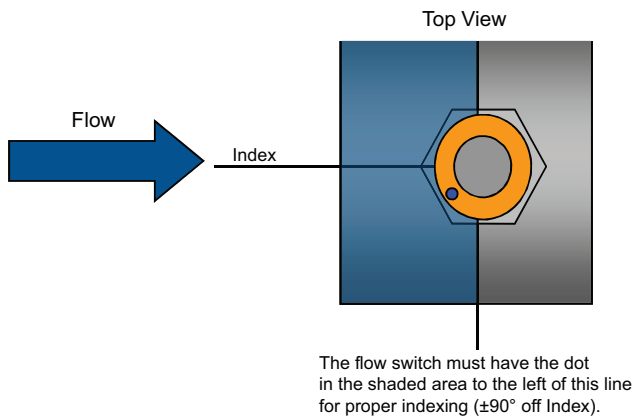

Evaporator Label

The BPHE evaporator label, including barcode, is located under the insulation, in the locations shown in following

Figure 32. BPHE label locations

20T BPHE - P80

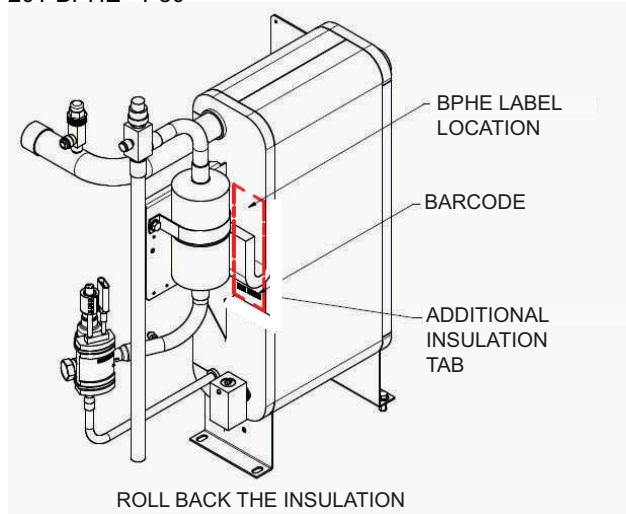

40T BPHE - DP200

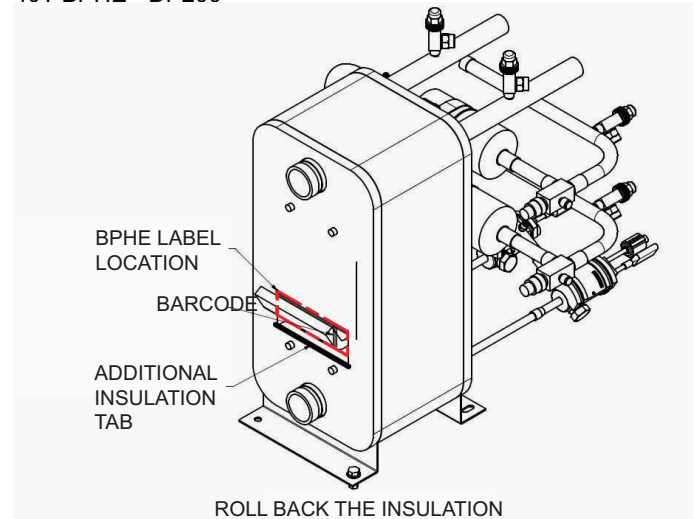

26/30/36T BPHE - P120

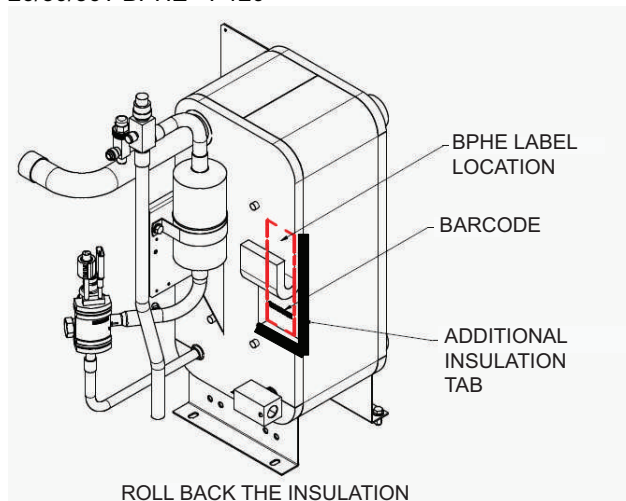

52-130T BPHE - DP400

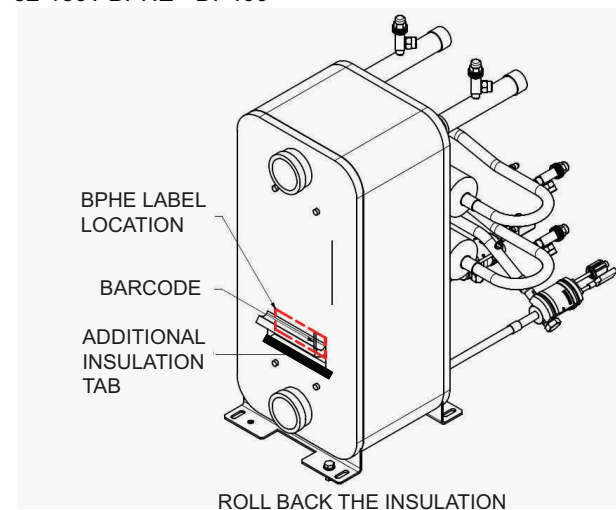

figure. Insulation backing over this area has not been removed, so that it can be rolled back to access BPHE label.

Pressure Drop Curves

Notes: See tables in "General Information," p. 10 for the following:

- Limit values for overlapping curves.
- Higher minimum flow rates required for units with evaporator leaving water temperature between 40°F and 41.9°F.

Figure 33. Total unit pressure drop curves (60 Hz)

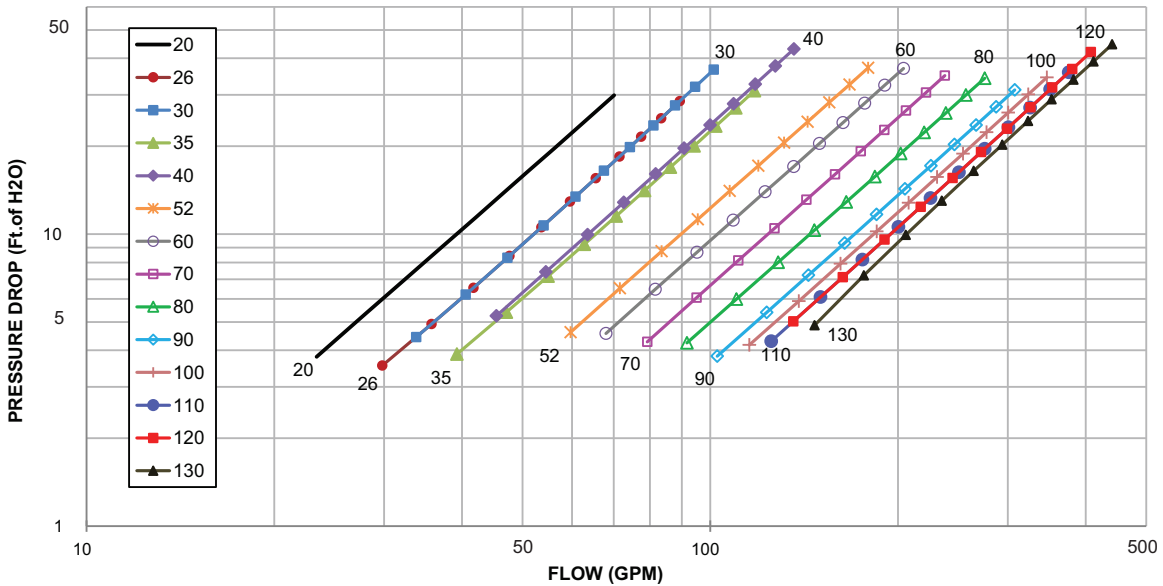
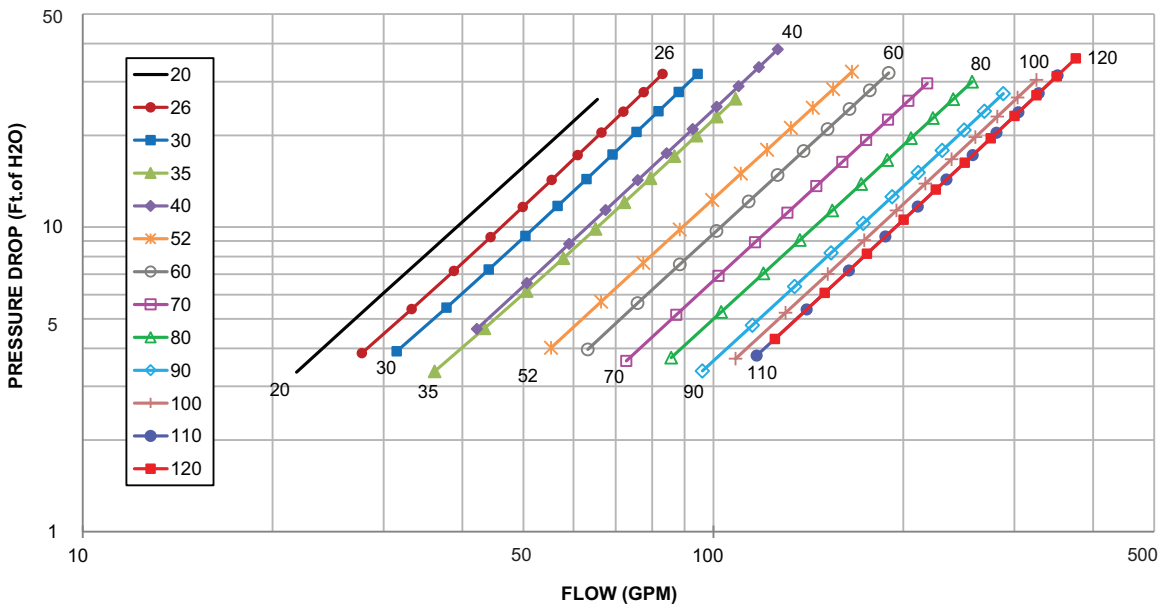

Figure 34. Total unit pressure drop curves (50 Hz)



Ambient Freeze Avoidance

Note: CGAM chillers use brazed plate heat exchangers, which are NOT at risk for refrigerant migration freeze. Chiller must only be protected from freeze due to low ambient conditions.

One or more of the ambient freeze avoidance methods in [Table 25, p. 45](#) must be used to protect the CGAM chiller from ambient freeze damage.

Table 25. CGAM ambient freeze avoidance methods

Method	Protects To Ambient Temperature	Notes
Water Pump Control	Down to 0°F	<ul style="list-style-type: none"> Symbio™ 800 controller can start the pump when the ambient temperatures drops to prevent freezing. For this option the pump must to be controlled by the CGAM unit and this function must be validated. Water circuit valves need to stay open at all times. If dual high head pump package option is selected, the chiller MUST control the pumps.
Heaters	Down to -20°F	<ul style="list-style-type: none"> This option is not applicable for units ordered with “No Freeze Protection” (model number digit 18 = X). Factory mounted heaters are NOT installed on these units, and one of the other forms of freeze protection must be used. For units with freeze protection selected (model number digit 18 is “1”), heaters are factory-installed on the evaporator and water piping and will protect them from freezing in ambient temperatures down to -20°F (-29°C). Install heat tape on all water piping, pumps, and other components that may be damaged if exposed to freezing temperatures. Heat tape must be designed for low ambient temperature applications. Heat tape selection should be based on the lowest expected ambient temperature. See NOTICE below for important information.
Freeze Inhibitor	Varies. See “Low Evap Refrigerant Cutout/ Percent Glycol Recommendations,” p. 45.	<ul style="list-style-type: none"> Freeze protection can be accomplished by adding sufficient glycol to protect against freezing below the lowest ambient expected.
Drain Water Circuit	Below -20°F	<ul style="list-style-type: none"> Shut off the power supply to the unit and to all heaters. Purge the water circuit. Blow out the evaporator to ensure no liquid is left in the evaporator. By default the Symbio 800 freeze protection control is enabled and will request the start of the chilled water pump with ambient temperatures less than the evaporator low leaving water temperature setpoint. The pump remains ON until the minimum evaporator water temperature is greater than low leaving water temperature setpoint plus 7°C. The minimum on time for the pump is 5 minutes. If you do NOT want the Symbio 800 to start the pump when the ambient temperature drops to freezing, disable this freeze protection control.

NOTICE

Equipment Damage!

Failure to follow these instructions could result in equipment damage.

All heaters have separate power from the unit. All heaters must be energized or the unit controller must control the pumps when the unit is off (unless the water circuit is drained or sufficient glycol is used). In the event of prolonged power loss, neither heaters nor unit control of the pumps will protect the evaporator from catastrophic damage. In order to provide freeze protection in the event of a power loss you MUST drain the evaporator, use sufficient freeze inhibitor in the evaporator or provide back-up power for pump and/or heaters.

Low Evap Refrigerant Cutout/ Percent Glycol Recommendations

The table below shows the low evaporator temperature cutout for different glycol levels.

Additional glycol beyond the recommendations will adversely effect unit performance. The unit efficiency will be reduced and the saturated evaporator temperature will be reduced. For some operating conditions this effect can be significant.

If additional glycol is used, then use the actual percent glycol to establish the low refrigerant cutout setpoint.



Installation - Mechanical

Table 26. Low evap refrigerant temp cutout and low water temp cutout — ethylene glycol

% Glycol	Solution Freeze Point (°F)	Low Refrig Temp Cutout (°F)	Low Water Temp Cutout (°F)	FLOW >= 1.2 GPM/TON			FLOW >= 1.5 GPM/TON		
				Min Chilled Water Setpoint (°F)			Min Chilled Water Setpoint(°F)		
				Number of compressors			Number of compressors		
				2	4	6	2	4	6
0	32	22	36	42	42	42	41	40	40
1	31.6	21.6	35.6	42	40.1	39.2	40.6	39.1	38.6
2	31.0	21.0	35.0	42	39.5	38.6	40.0	38.5	38.0
3	30.3	20.3	34.3	41.3	38.8	38.0	39.3	37.8	37.3
4	29.7	19.7	33.7	40.7	38.2	37.3	38.7	37.2	36.7
5	29.0	19.0	33.0	40.0	37.5	36.7	38.0	36.5	36.0
6	28.3	18.3	32.3	39.3	36.8	36.0	37.3	35.8	35.3
7	27.6	17.6	31.6	38.6	36.1	35.3	36.6	35.1	34.6
8	26.9	16.9	30.9	37.9	35.4	34.6	35.9	34.4	33.9
9	26.2	16.2	30.2	37.2	34.7	33.9	35.2	33.7	33.2
10	25.5	15.5	29.5	36.5	34.0	33.1	34.5	33.0	32.5
11	24.7	14.7	28.7	35.7	33.2	32.4	33.7	32.2	31.7
12	23.9	13.9	27.9	34.9	32.4	31.6	32.9	31.4	30.9
13	23.1	13.1	27.1	34.1	31.6	30.8	32.1	30.6	30.1
14	22.3	12.3	26.3	33.3	30.8	30.0	31.3	29.8	29.3
15	21.5	11.5	25.5	32.5	30.0	29.1	30.5	29.0	28.5
16	20.6	10.6	24.6	31.6	29.1	28.2	29.6	28.1	27.6
17	19.7	9.7	23.7	30.7	28.2	27.3	28.7	27.2	26.7
18	18.7	8.7	22.7	29.7	27.2	26.4	27.7	26.2	25.7
19	17.8	7.8	21.8	28.8	26.3	25.5	26.8	25.3	24.8
20	16.8	6.8	20.8	27.8	25.3	24.5	25.8	24.3	23.8
21	15.8	5.8	19.8	26.8	24.3	23.5	24.8	23.3	22.8
22	14.7	4.7	18.7	25.7	23.2	22.4	23.7	22.2	21.7
23	13.7	3.7	17.7	24.7	22.2	21.3	22.7	21.2	20.7
24	12.5	2.5	16.5	23.5	21.0	20.2	21.5	20.0	19.5
25	11.4	1.4	15.4	22.4	19.9	19.1	20.4	18.9	18.4
26	10.2	0.2	14.2	21.2	18.7	17.9	19.2	17.7	17.2
27	9.0	-1.0	13.0	20.0	17.5	16.7	18.0	16.5	16.0
28	7.7	-2.3	11.7	18.7	16.2	15.4	16.7	15.2	14.7
29	6.4	-3.6	10.4	17.4	14.9	14.1	15.4	13.9	13.4
30	5.1	-4.9	9.1	16.1	13.6	12.8	14.1	12.6	12.1
31	3.7	-6.3	7.7	14.7	12.2	11.4	12.7	11.2	10.7
32	2.3	-7.7	6.3	13.3	10.8	9.9	11.3	9.8	9.3
33	0.8	-9.2	4.8	11.8	9.3	8.5	9.8	8.3	7.8
34	-0.7	-10.7	3.3	10.3	7.8	7.0	8.3	6.8	6.3
35	-2.3	-12.3	1.7	8.7	6.2	5.4	6.7	5.2	4.7
36	-3.9	-13.9	0.1	7.1	4.6	3.8	5.1	3.6	3.1
37	-5.6	-15.6	-1.6	5.4	2.9	2.1	3.4	1.9	1.4
38	-7.3	-17.3	-3.3	3.7	1.2	0.4	1.7	0.2	0.0
39	-9.0	-19.0	-5.0	2.0	0.0	0.0	0.0	0.0	0.0
40	-10.8	-20.8	-6.8	0.2	0.0	0.0	0.0	0.0	0.0
41	-12.7	-21.0	-7.0	0.0	0.0	0.0	0.0	0.0	0.0
42	-14.6	-21.0	-7.0	0.0	0.0	0.0	0.0	0.0	0.0
43	-16.6	-21.0	-7.0	0.0	0.0	0.0	0.0	0.0	0.0

Table 26. Low evap refrigerant temp cutout and low water temp cutout — ethylene glycol (continued)

% Glycol	Solution Freeze Point (°F)	Low Refrig Temp Cutout (°F)	Low Water Temp Cutout (°F)	FLOW >= 1.2 GPM/TON			FLOW >= 1.5 GPM/TON		
				Min Chilled Water Setpoint (°F)			Min Chilled Water Setpoint(°F)		
				Number of compressors			Number of compressors		
				2	4	6	2	4	6
44	-18.6	-21.0	-7.0	0.0	0.0	0.0	0.0	0.0	0.0
45	-20.7	-21.0	-7.0	0.0	0.0	0.0	0.0	0.0	0.0
46	-22.9	-21.0	-7.0	0.0	0.0	0.0	0.0	0.0	0.0
47	-25.1	-21.0	-7.0	0.0	0.0	0.0	0.0	0.0	0.0
48	-27.3	-21.0	-7.0	0.0	0.0	0.0	0.0	0.0	0.0
49	-29.7	-21.0	-7.0	0.0	0.0	0.0	0.0	0.0	0.0
50	-32.1	-21.0	-7.0	0.0	0.0	0.0	0.0	0.0	0.0
51	-34.5	-21.0	-7.0	0.0	0.0	0.0	0.0	0.0	0.0
52	-37.1	-21.0	-7.0	0.0	0.0	0.0	0.0	0.0	0.0
53	-39.7	-21.0	-7.0	0.0	0.0	0.0	0.0	0.0	0.0
54	-42.3	-21.0	-7.0	0.0	0.0	0.0	0.0	0.0	0.0
55	-45.0	-21.0	-7.0	0.0	0.0	0.0	0.0	0.0	0.0

Table 27. Low evap refrigerant temp cutout and low water temp cutout — propylene glycol

% Glycol	Solution Freeze Point (°F)	Low Refrig Temp Cutout (°F)	Low Water Temp Cutout (°F)	FLOW >= 1.2 GPM/TON			FLOW >= 1.5 GPM/TON		
				Min Chilled Water Setpoint (°F)			Min Chilled Water Setpoint(°F)		
				Number of compressors			Number of compressors		
				2	4	6	2	4	6
0	32	22	36	42	42	42	41	40	40
1	31.6	21.6	35.6	42	40.1	39.2	40.6	39.1	38.6
2	31.0	21.0	35.0	42	39.5	38.7	40.0	38.5	38.0
3	30.4	20.4	34.4	41.4	38.9	38.1	39.4	37.9	37.4
4	29.9	19.9	33.9	40.9	38.4	37.5	38.9	37.4	36.9
5	29.3	19.3	33.3	40.3	37.8	37.0	38.3	36.8	36.3
6	28.7	18.7	32.7	39.7	37.2	36.4	37.7	36.2	35.7
7	28.1	18.1	32.1	39.1	36.6	35.8	37.1	35.6	35.1
8	27.6	17.6	31.6	38.6	36.1	35.2	36.6	35.1	34.6
9	27.0	17.0	31.0	38.0	35.5	34.6	36.0	34.5	34.0
10	26.4	16.4	30.4	37.4	34.9	34.0	35.4	33.9	33.4
11	25.7	15.7	29.7	36.7	34.2	33.4	34.7	33.2	32.7
12	25.1	15.1	29.1	36.1	33.6	32.8	34.1	32.6	32.1
13	24.4	14.4	28.4	35.4	32.9	32.1	33.4	31.9	31.4
14	23.8	13.8	27.8	34.8	32.3	31.4	32.8	31.3	30.8
15	23.1	13.1	27.1	34.1	31.6	30.7	32.1	30.6	30.1
16	22.4	12.4	26.4	33.4	30.9	30.0	31.4	29.9	29.4
17	21.6	11.6	25.6	32.6	30.1	29.3	30.6	29.1	28.6
18	20.9	10.9	24.9	31.9	29.4	28.5	29.9	28.4	27.9
19	20.1	10.1	24.1	31.1	28.6	27.8	29.1	27.6	27.1
20	19.3	9.3	23.3	30.3	27.8	26.9	28.3	26.8	26.3
21	18.4	8.4	22.4	29.4	26.9	26.1	27.4	25.9	25.4
22	17.6	7.6	21.6	28.6	26.1	25.2	26.6	25.1	24.6
23	16.7	6.7	20.7	27.7	25.2	24.3	25.7	24.2	23.7
24	15.7	5.7	19.7	26.7	24.2	23.4	24.7	23.2	22.7
25	14.8	4.8	18.8	25.8	23.3	22.4	23.8	22.3	21.8



Installation - Mechanical

Table 27. Low evap refrigerant temp cutout and low water temp cutout — propylene glycol (continued)

% Glycol	Solution Freeze Point (°F)	Low Refrig Temp Cutout (°F)	Low Water Temp Cutout (°F)	FLOW >= 1.2 GPM/TON			FLOW >= 1.5 GPM/TON		
				Min Chilled Water Setpoint (°F)			Min Chilled Water Setpoint(°F)		
				Number of compressors			Number of compressors		
				2	4	6	2	4	6
26	13.8	3.8	17.8	24.8	22.3	21.4	22.8	21.3	20.8
27	12.7	2.7	16.7	23.7	21.2	20.4	21.7	20.2	19.7
28	11.6	1.6	15.6	22.6	20.1	19.3	20.6	19.1	18.6
29	10.5	0.5	14.5	21.5	19.0	18.2	19.5	18.0	17.5
30	9.3	-0.7	13.3	20.3	17.8	17.0	18.3	16.8	16.3
31	8.1	-1.9	12.1	19.1	16.6	15.8	17.1	15.6	15.1
32	6.8	-3.2	10.8	17.8	15.3	14.5	15.8	14.3	13.8
33	5.5	-4.5	9.5	16.5	14.0	13.2	14.5	13.0	12.5
34	4.1	-5.9	8.1	15.1	12.6	11.8	13.1	11.6	11.1
35	2.7	-7.3	6.7	13.7	11.2	10.4	11.7	10.2	9.7
36	1.3	-8.7	5.3	12.3	9.8	8.9	10.3	8.8	8.3
37	-0.3	-10.3	3.7	10.7	8.2	7.4	8.7	7.2	6.7
38	-1.8	-11.8	2.2	9.2	6.7	5.8	7.2	5.7	5.2
39	-3.5	-13.5	0.5	7.5	5.0	4.2	5.5	4.0	3.5
40	-5.2	-15.2	-1.2	5.8	3.3	2.5	3.8	2.3	1.8
41	-6.9	-16.9	-2.9	4.1	1.6	0.7	2.1	0.6	0.1
42	-8.8	-18.8	-4.8	2.2	0.0	0.0	0.2	0.0	0.0
43	-10.7	-20.7	-6.7	0.3	0.0	0.0	0.0	0.0	0.0
44	-12.6	-21.0	-7.0	0.0	0.0	0.0	0.0	0.0	0.0
45	-14.6	-21.0	-7.0	0.0	0.0	0.0	0.0	0.0	0.0
46	-16.7	-21.0	-7.0	0.0	0.0	0.0	0.0	0.0	0.0
47	-18.9	-21.0	-7.0	0.0	0.0	0.0	0.0	0.0	0.0
48	-21.1	-21.0	-7.0	0.0	0.0	0.0	0.0	0.0	0.0
49	-23.4	-21.0	-7.0	0.0	0.0	0.0	0.0	0.0	0.0
50	-25.8	-21.0	-7.0	0.0	0.0	0.0	0.0	0.0	0.0
51	-28.3	-21.0	-7.0	0.0	0.0	0.0	0.0	0.0	0.0
52	-30.8	-21.0	-7.0	0.0	0.0	0.0	0.0	0.0	0.0
53	-33.4	-21.0	-7.0	0.0	0.0	0.0	0.0	0.0	0.0
54	-36.1	-21.0	-7.0	0.0	0.0	0.0	0.0	0.0	0.0
55	-38.9	-21.0	-7.0	0.0	0.0	0.0	0.0	0.0	0.0

Performance Adjustment Factors

Concentration and type of glycol used will affect unit performance. If operating conditions, including concentration of freeze inhibitor, have changed since the unit was ordered, contact sales representative to rerun selection. See following figures for approximate adjustment factors.

Figure 35. Ethylene - compressor power adjustment

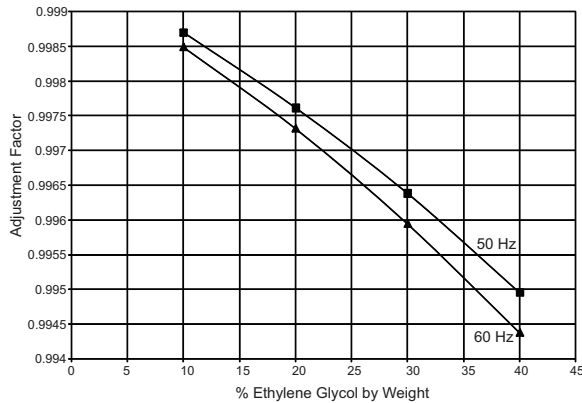

Figure 36. Propylene - compressor power adjustment

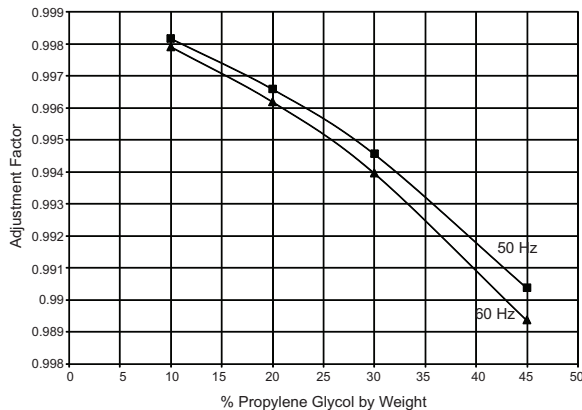

Figure 37. Ethylene - GPM adjustment

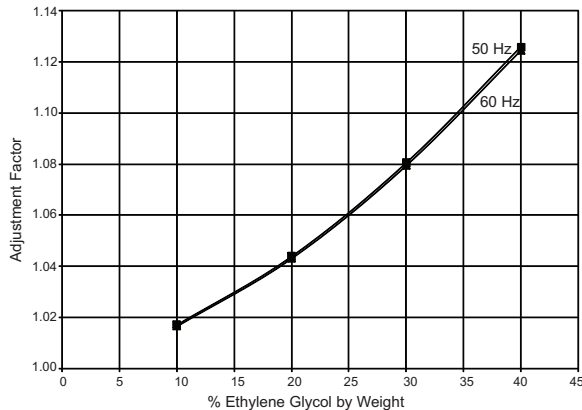

Figure 38. Propylene - GPM adjustment

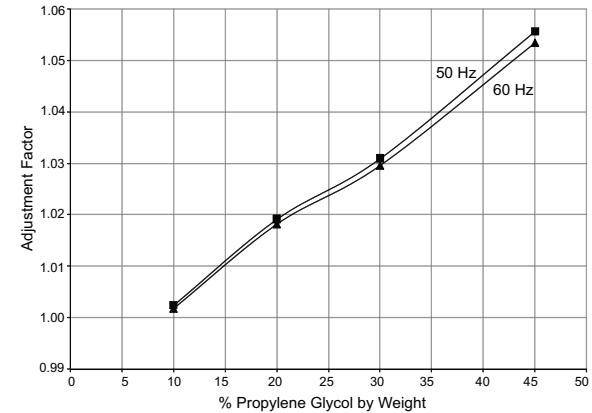

Figure 39. Ethylene - capacity adjustment

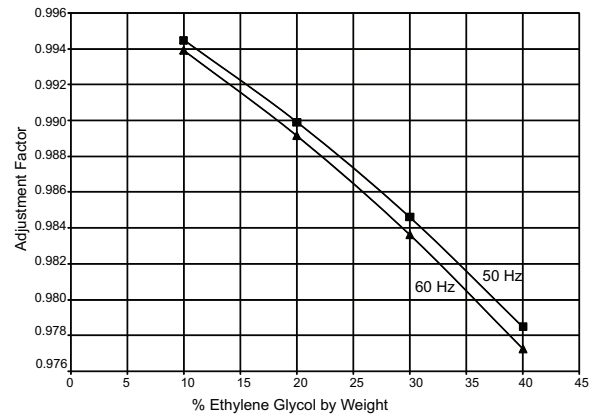
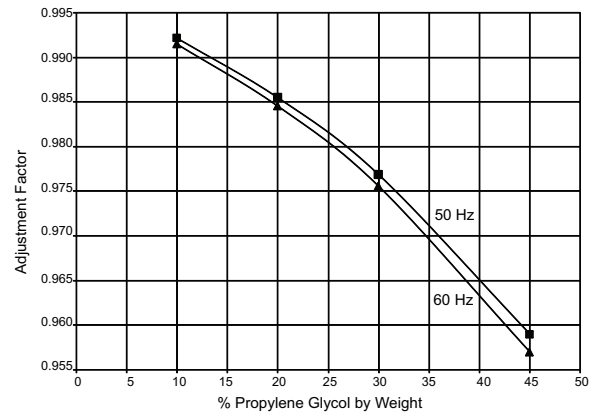

Figure 40. Propylene - capacity adjustment



Dual High Head Pump Package

Pump package includes: two high head pumps, VFD, expansion vessels, drainage valves, shut-off valves at entering and leaving connections. See [Figure 42, p. 50](#).

The pump package is single point power integrated into the chiller unit power with a separate factory wired control panel. The control of the pump is integrated into the chiller controller.

Important: When pump package is selected, the chiller **MUST** control the pumps.

The Symbio™ 800 displays evaporator pump starts and run-times. Freeze protection down to an ambient of -20°F (-29°C) is included as standard. The cold parts of the pump package will also be insulated. Designed with one redundant pump, the chiller controls both pumps through a lead/lag and failure/recovery functionality.

A variable speed drive is installed in an additional panel to control the pump. The inverter should be adjusted by the customer upon start-up to balance the system flow and head requirements. The purpose is to save on wasted pump energy caused by a traditional balancing valve.

Note: Speed command is also available for customer provided variable flow input.

Figure 41. Field water piping pump package unit

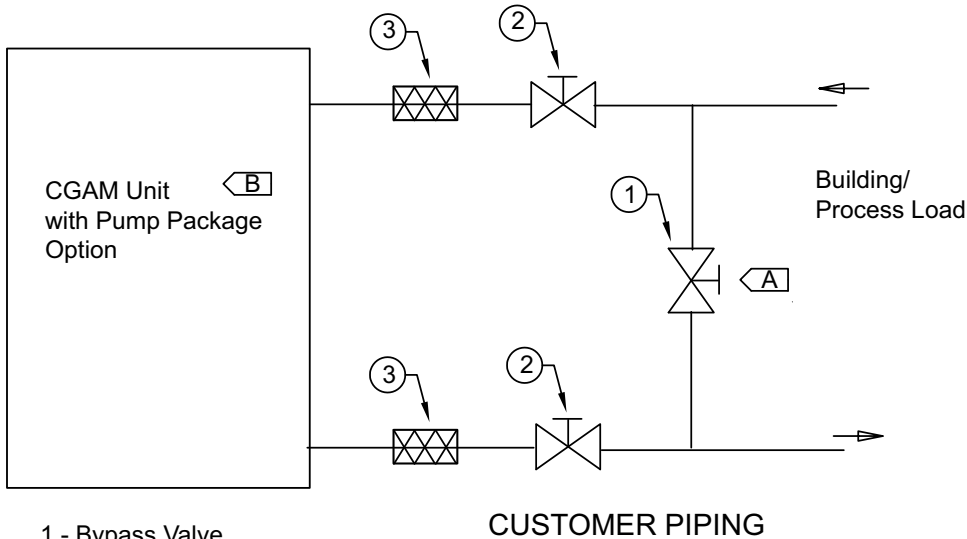

- 1 - Bypass Valve
- 2 - Isolation Valve
- 3 - Vibration Eliminators
- A - Isolate unit for initial water loop cleaning

Table 28. Field water piping pump package unit

Item	Description
1	Bypass Valve
2	Isolator Valve
3	Vibration Eliminator

Table 28. Field water piping pump package unit (continued)

Item	Description
A	Isolate unit for initial water loop cleaning
B	See Figure 42, p. 50 for CGAM pump package unit schematic.

Figure 42. Pump package unit schematic

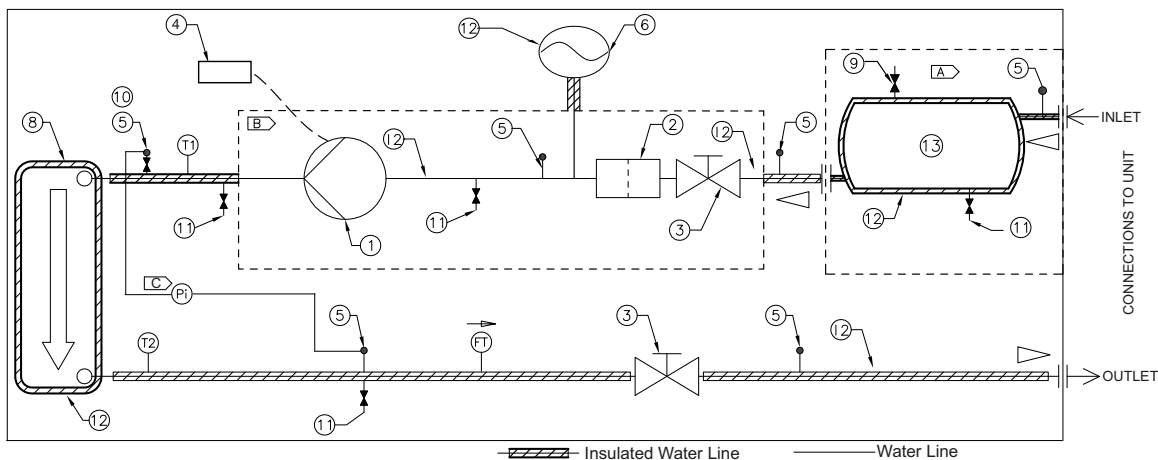

Table 29. Pump package components

Item	Description	Item	Description	Item	Description
1	Centrifugal Pump (Dual Pumps Std)	8	Evaporator Heat Exchanger	Pi	Gauge
2	Water Strainer	9	Automatic Air Vent	FT	Water Flow Switch
3	Butterfly Valve	10	Manual Air Bleed	T1	Evap Water Inlet Temp Sensor
4	Inverter	11	Drain Valve	T2	Evap Water Outlet Temp Sensor
5	Valve for Pressure Point	12	Water Heater	A	Optional Buffer Tank
6	Expansion Tank	13	Buffer Tank (Optional)	B	Insulated Pump Box
7	N/A			C	Brazed plate differential pressure gauge and piping not supplied. Must account for water head height difference when calculating brazed plate pressure differential.

Pressure Drop Information - Units with Optional Pump Package

Water only

Factory Installed Pump Package - Pump Curves

Figure 43, p. 51 through Figure 46, p. 53 show manufacturer pump curves for factory-installed pump package.

Figure 43. Pump curve, 20 to 52 ton units, water only

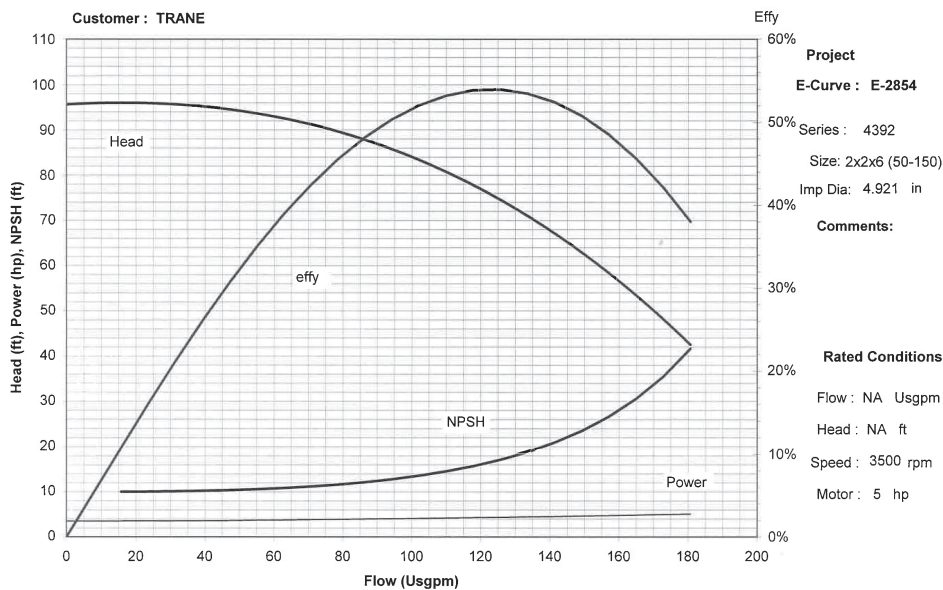



Installation - Mechanical

Figure 44. Pump curve, 60 to 70 ton units, water only

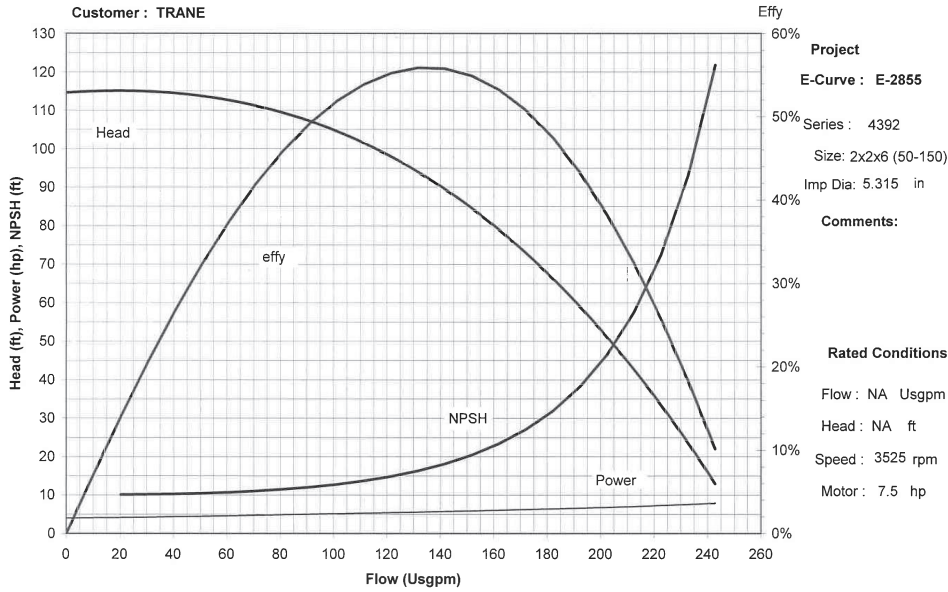

Figure 45. Pump curve, 80 to 110 ton units, water only

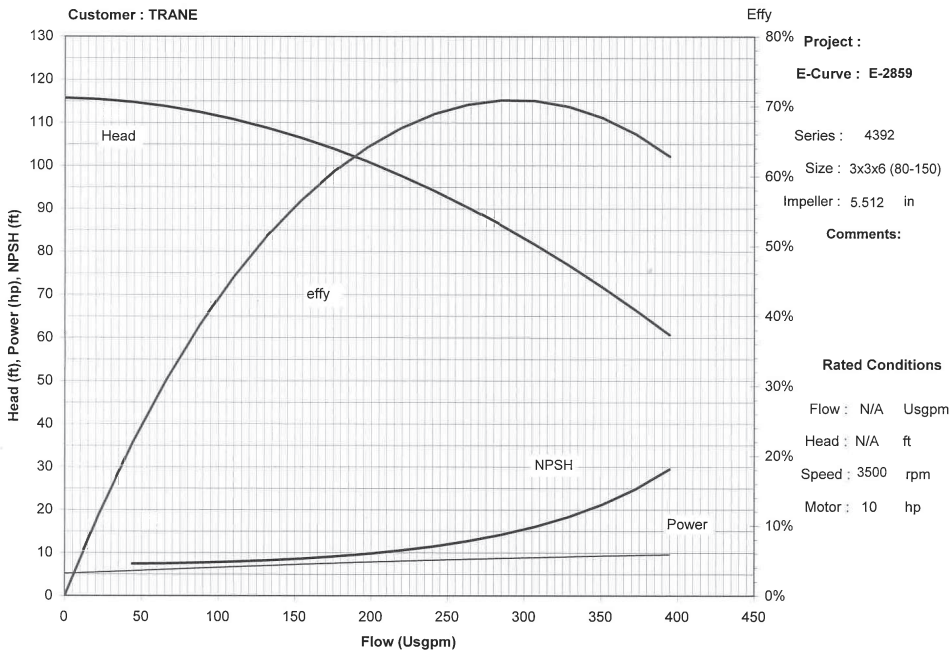
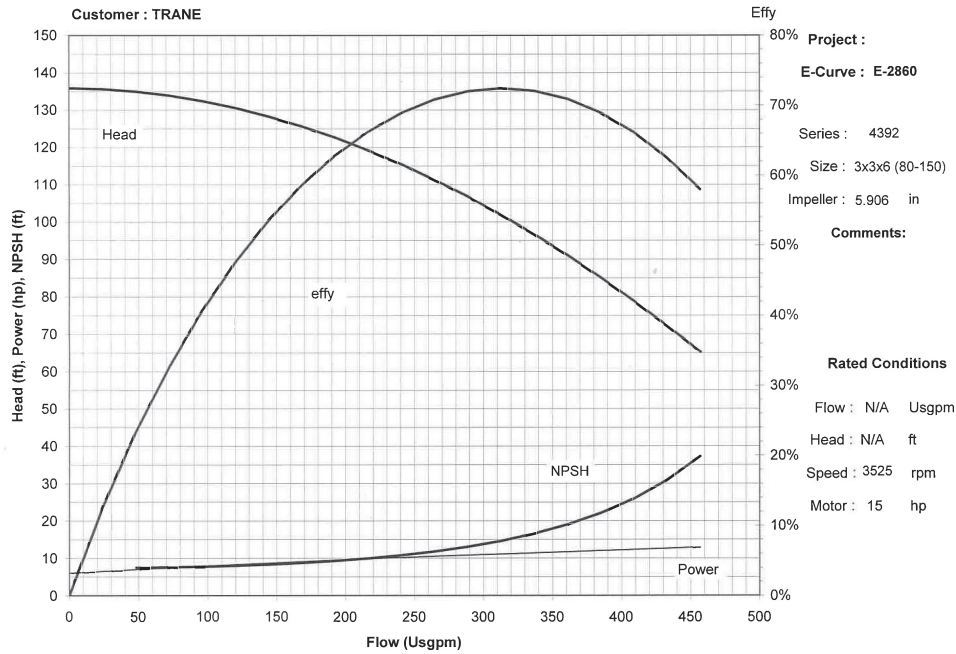

Figure 46. Pump curve, 120 to 130 ton units, water only



Unit Component Pressure Drop

Figure 47, p. 53 shows the pressure drop values for unit components, including evaporator, strainer, piping and valves.

Figure 47. Unit component pressure drop, water only

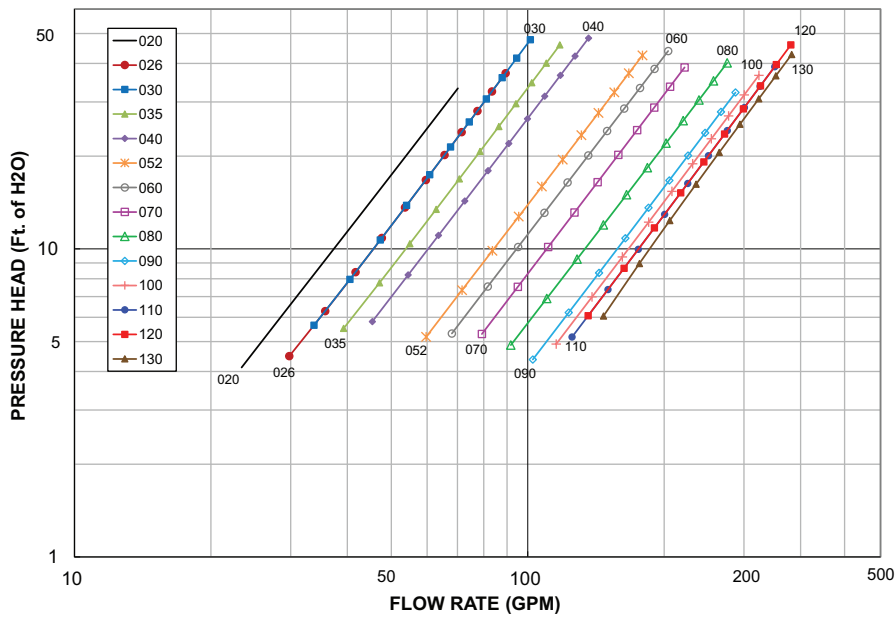



Installation - Mechanical

System Head Pressure

See Figure 48, p. 54 for the system head pressure available.

Note: System Head Pressure = Pump Pressure - Component Pressure

Figure 48. CGAM pump package available head pressure, water only

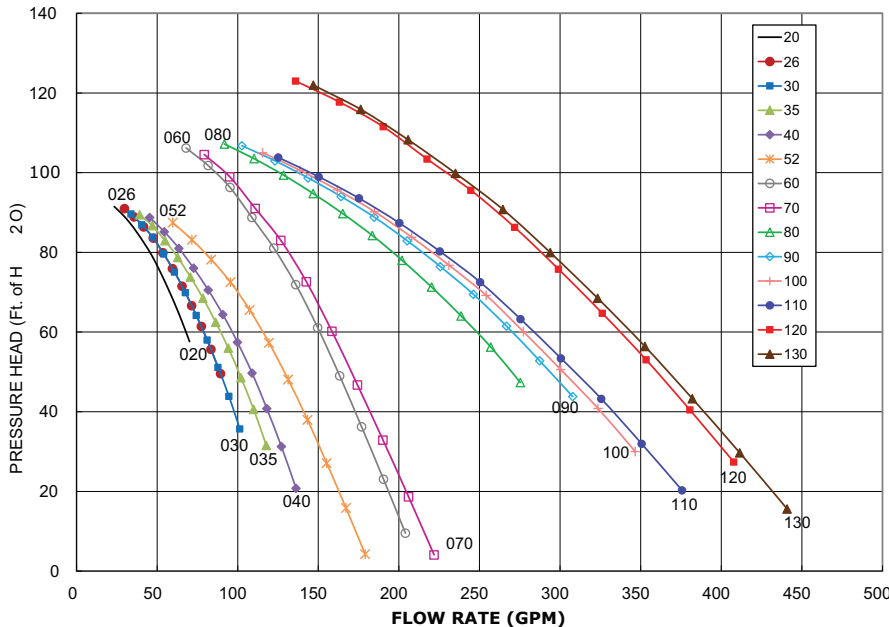

Unit with Optional Pump Package Systems - Glycol

If using glycol in system, apply adjustment factors to pressure drops per the following formulas:

- Glycol Pump Head = Water Pump Head x Pump Adjustment Factor
- Glycol Component Pressure Drop = Components Pressure Drop x Component Adjustment Factor

Notes:

- For Water Pump Head, see Figure 43, p. 51 through Figure 46, p. 53.
- For Component Pressure Drop, see Figure 47, p. 53.
- For Pump and Component Adjustment Factors, see Table 30, p. 54.

Table 30. Brine adjustment factors

Percentage Glycol	Ethylene Glycol		Propylene Glycol	
	Adjustment for		Adjustment for	
	Pump	Components	Pump	Components
5%	1.004	1.085	1.004	1.165
10%	1.009	1.120	1.009	1.200
15%	1.015	1.155	1.015	1.235
20%	1.021	1.190	1.021	1.270

Table 30. Brine adjustment factors (continued)

Percentage Glycol	Ethylene Glycol		Propylene Glycol	
	Adjustment for		Adjustment for	
	Pump	Components	Pump	Components
25%	1.028	1.235	1.028	1.300
30%	1.034	1.280	1.034	1.330
35%	1.040	1.345	1.040	1.365
40%	1.046	1.410	1.046	1.400
45%	-	-	1.051	1.460

Pump Package Requirements

The following requirements must be met for proper operation of pump package:

- Maximum working pressure 150 psig
- Fluid type shown in Table 31, p. 54.

Table 31. Working fluid

Fluid Type	Fluid Percent (of weight)
Water	100%
Ethylene Glycol	0-40%
Propylene Glycol	0-45%

- Customer pressure drop must not exceed pump package head pressures found in “General Information,” p. 10.
- If buffer tank option is selected, customer water volume must not exceed the values in Table 32, p. 55 and Table 33, p. 56. User volume expansion capacity is defined as the additional expansion volume usable for the customer if the chiller is installed with pump package and buffer tank options.

for maximum loop volumes shown in Table 32, p. 55 and Table 33, p. 56.

Note: Negative values indicate that a field-installed tank is required to cover the expansion due to ambient fluctuations of the fluid in the chiller.

Important: Chilled waterside pressure relief valve is designed to open at 226 ft. If relief valve is opening at lower pressures, verify system has sufficient expansion tank volume for the water and/or glycol solution used.

Expansion Tank - Maximum Loop Volume

Expansion tanks supplied as part of the pump package option will allow loop expansion due to ambient fluctuations

Table 32. Maximum loop volume — gallons (external to the chiller)

Size	Maximum Ambient = 100°F										Maximum Ambient = 115°F											
	Water	% Ethylene Glycol					% Propylene Glycol					Water	% Ethylene Glycol					% Propylene Glycol				
		10	20	30	40	10	20	30	40	45	10		20	30	40	10	20	30	40	45		
Without Buffer Tank																						
20	479	433	296	199	148	292	198	139	108	98	317	293	216	155	120	222	155	112	87	80		
26	479	433	296	199	148	292	198	139	108	98	317	293	216	155	120	222	155	112	87	80		
30	479	433	296	199	148	292	198	139	108	98	317	293	216	155	120	222	155	112	87	80		
35	479	433	296	199	148	292	198	139	108	98	317	293	216	155	120	222	155	112	87	80		
40	474	428	291	194	143	286	193	134	102	93	312	287	211	150	114	216	149	106	82	75		
52	474	428	291	194	143	286	193	134	102	93	312	287	211	150	114	216	149	106	82	75		
60	474	428	291	194	143	286	193	134	102	93	312	287	211	150	114	216	149	106	82	75		
70	474	428	291	194	143	286	193	134	102	93	312	287	211	150	114	216	149	106	82	75		
80	626	565	383	253	185	377	252	174	131	119	411	378	276	194	147	283	194	136	104	95		
90	626	565	383	253	185	377	252	174	131	119	411	378	276	194	147	283	194	136	104	95		
100	626	565	383	253	185	377	252	174	131	119	411	378	276	194	147	283	194	136	104	95		
110	626	565	383	253	185	377	252	174	131	119	411	378	276	194	147	283	194	136	104	95		
120	626	565	383	253	185	377	252	174	131	119	411	378	276	194	147	283	194	136	104	95		
130	626	565	383	253	185	377	252	174	131	119	411	378	276	194	147	283	194	136	104	95		
With Buffer Tank																						
20	335	289	152	55	4	148	54	-5	-36	-46	173	149	72	11	-24	78	11	-32	-57	-64		
26	335	289	152	55	4	148	54	-5	-36	-46	173	149	72	11	-24	78	11	-32	-57	-64		
30	335	289	152	55	4	148	54	-5	-36	-46	173	149	72	11	-24	78	11	-32	-57	-64		
35	335	289	152	55	4	148	54	-5	-36	-46	173	149	72	11	-24	78	11	-32	-57	-64		
40	338	292	155	58	7	150	57	-2	-34	-43	176	151	75	14	-22	80	13	-30	-54	-61		
52	338	292	155	58	7	150	57	-2	-34	-43	176	151	75	14	-22	80	13	-30	-54	-61		
60	338	292	155	58	7	150	57	-2	-34	-43	176	151	75	14	-22	80	13	-30	-54	-61		
70	338	292	155	58	7	150	57	-2	-34	-43	176	151	75	14	-22	80	13	-30	-54	-61		
80	470	409	226	97	29	220	96	17	-25	-38	254	221	119	38	-9	127	38	-20	-52	-62		
90	470	409	226	97	29	220	96	17	-25	-38	254	221	119	38	-9	127	38	-20	-52	-62		
100	425	364	181	52	-16	175	51	-28	-70	-83	210	177	74	-7	-54	82	-7	-65	-97	-107		
110	425	364	181	52	-16	175	51	-28	-70	-83	210	177	74	-7	-54	82	-7	-65	-97	-107		
120	425	364	181	52	-16	175	51	-28	-70	-83	210	177	74	-7	-54	82	-7	-65	-97	-107		
130	425	364	181	52	-16	175	51	-28	-70	-83	210	177	74	-7	-54	82	-7	-65	-97	-107		



Installation - Mechanical

Table 33. Maximum loop volume — liters (external to the chiller)

Size	Maximum Ambient = 100°F										Maximum Ambient = 115°F											
	Water	% Ethylene Glycol					% Propylene Glycol					Water	% Ethylene Glycol					% Propylene Glycol				
		10	20	30	40	10	20	30	40	45	10		20	30	40	10	20	30	40	45		
Without Buffer Tank																						
20	1813	1639	1121	754	561	1104	751	528	407	372	1201	1108	818	587	453	839	586	422	331	303		
26	1813	1639	1121	754	561	1104	751	528	407	372	1201	1108	818	587	453	839	586	422	331	303		
30	1813	1639	1121	754	561	1104	751	528	407	372	1201	1108	818	587	453	839	586	422	331	303		
35	1813	1639	1121	754	561	1104	751	528	407	372	1201	1108	818	587	453	839	586	422	331	303		
40	1793	1619	1101	734	541	1084	731	508	387	352	1181	1088	798	567	433	819	566	402	311	283		
52	1793	1619	1101	734	541	1084	731	508	387	352	1181	1088	798	567	433	819	566	402	311	283		
60	1793	1619	1101	734	541	1084	731	508	387	352	1181	1088	798	567	433	819	566	402	311	283		
70	1793	1619	1101	734	541	1084	731	508	387	352	1181	1088	798	567	433	819	566	402	311	283		
80	2370	2139	1448	958	701	1426	955	657	496	449	1555	1430	1044	736	558	1072	735	516	394	358		
90	2370	2139	1448	958	701	1426	955	657	496	449	1555	1430	1044	736	558	1072	735	516	394	358		
100	2370	2139	1448	958	701	1426	955	657	496	449	1555	1430	1044	736	558	1072	735	516	394	358		
110	2370	2139	1448	958	701	1426	955	657	496	449	1555	1430	1044	736	558	1072	735	516	394	358		
120	2370	2139	1448	958	701	1426	955	657	496	449	1555	1430	1044	736	558	1072	735	516	394	358		
130	2370	2139	1448	958	701	1426	955	657	496	449	1555	1430	1044	736	558	1072	735	516	394	358		
With Buffer Tank																						
20	1268	1094	576	209	16	559	206	-17	-138	-173	656	563	273	42	-92	294	41	-123	-214	-242		
26	1268	1094	576	209	16	559	206	-17	-138	-173	656	563	273	42	-92	294	41	-123	-214	-242		
30	1268	1094	576	209	16	559	206	-17	-138	-173	656	563	273	42	-92	294	41	-123	-214	-242		
35	1268	1094	576	209	16	559	206	-17	-138	-173	656	563	273	42	-92	294	41	-123	-214	-242		
40	1278	1104	586	219	26	569	216	-7	-128	-163	666	573	283	52	-82	304	51	-113	-204	-232		
52	1278	1104	586	219	26	569	216	-7	-128	-163	666	573	283	52	-82	304	51	-113	-204	-232		
60	1278	1104	586	219	26	569	216	-7	-128	-163	666	573	283	52	-82	304	51	-113	-204	-232		
70	1278	1104	586	219	26	569	216	-7	-128	-163	666	573	283	52	-82	304	51	-113	-204	-232		
80	1778	1547	856	366	109	834	363	65	-96	-143	963	838	452	144	-34	480	143	-76	-198	-234		
90	1778	1547	856	366	109	834	363	65	-96	-143	963	838	452	144	-34	480	143	-76	-198	-234		
100	1608	1377	686	196	-61	664	193	-105	-266	-313	793	668	282	-26	-204	310	-27	-246	-368	-404		
110	1608	1377	686	196	-61	664	193	-105	-266	-313	793	668	282	-26	-204	310	-27	-246	-368	-404		
120	1608	1377	686	196	-61	664	193	-105	-266	-313	793	668	282	-26	-204	310	-27	-246	-368	-404		
130	1608	1377	686	196	-61	664	193	-105	-266	-313	793	668	282	-26	-204	310	-27	-246	-368	-404		



Installation Electrical

General Recommendations

As you review this manual, keep in mind that:

- All field-installed wiring must conform to National Electric Code (NEC) guidelines, and any applicable state and local codes. Be sure to satisfy proper equipment grounding requirements per NEC.
- Compressor motor and unit electrical data (including motor kW, voltage utilization range, rated load amps) is listed on the chiller nameplate.
- All field-installed wiring must be checked for proper terminations, and for possible shorts or grounds.

Note: Always refer to wiring diagrams shipped with chiller or unit submittal for specific electrical schematic and connection information.

⚠ WARNING

Hazardous Voltage - Pressurized Flammable Fluid!

Failure to follow all electrical safety precautions could result in death or serious injury.

Do not operate compressor without terminal box cover in place.

The motors in the compressors have strong permanent magnet motors and have the capability to generate voltage during situations when the refrigerant charge is being migrated. This potential will be present at the motor terminals and at the output of the variable speed drives in the power panel.

Before removing compressor terminal box cover for servicing, or servicing power side of control panel, **CLOSE COMPRESSOR DISCHARGE SERVICE VALVE** and disconnect all electric power including remote disconnects. Discharge all motor start/run capacitors. Follow lockout/tagout procedures to ensure the power cannot be inadvertently energized. Verify with an appropriate voltmeter that all capacitors have discharged.

The compressor contains hot, pressurized refrigerant. Motor terminals act as a seal against this refrigerant. Care should be taken when servicing **NOT** to damage or loosen motor terminals.

⚠ WARNING

Hazardous Voltage!

Failure to disconnect power before servicing could result in death or serious injury.

Disconnect all electric power, including remote disconnects before servicing. Follow proper lockout/tagout procedures to ensure the power can not be inadvertently energized. Verify that no power is present with a voltmeter.

⚠ WARNING

Proper Field Wiring and Grounding Required!

Failure to follow code could result in death or serious injury.

All field wiring **MUST** be performed by qualified personnel. Improperly installed and grounded field wiring poses **FIRE** and **ELECTROCUTION** hazards. To avoid these hazards, you **MUST** follow requirements for field wiring installation and grounding as described in NEC and your local/state/national electrical codes.

NOTICE

Use Copper Conductors Only!

Failure to use copper conductors could result in equipment damage as the equipment was not designed or qualified to accept other types of conductors.

NOTICE

Equipment Damage!

Failure to follow these instructions could result in equipment damage.

The motor harness attached to the single plug to which the motor mates contains the 115V motor voltage jumper. The motor harness should always be present for 115V units and should not be modified or substituted.

Installer-Supplied Components

Customer wiring interface connections are shown in the electrical schematics and connection diagrams that are shipped with the unit. The installer must provide the following components if not ordered with the unit:

- Power supply wiring (in conduit) for all field-wired connections.
- All control (interconnecting) wiring (in conduit) for field supplied devices.
- Circuit breakers.



Power Supply Wiring

⚠ WARNING

Proper Field Wiring and Grounding Required!

Failure to follow code could result in death or serious injury.

All field wiring **MUST** be performed by qualified personnel. Improperly installed and grounded field wiring poses **FIRE** and **ELECTROCUTION** hazards. To avoid these hazards, you **MUST** follow requirements for field wiring installation and grounding as described in **NEC** and your local/state/national electrical codes.

All power supply wiring must be sized and selected accordingly by the project engineer in accordance with NEC Table 310-16.

⚠ WARNING

Hazardous Voltage!

Failure to disconnect power before servicing could result in death or serious injury.

Disconnect all electric power, including remote disconnects before servicing. Follow proper lockout/tagout procedures to ensure the power can not be inadvertently energized. Verify that no power is present with a voltmeter.

All wiring must comply with local codes and the National Electrical Code. The installing (or electrical) contractor must provide and install the system interconnecting wiring, as well as the power supply wiring. It must be properly sized and equipped with the appropriate fused disconnect switches.

The type and installation location(s) of the fused disconnects must comply with all applicable codes.

NOTICE

Use Copper Conductors Only!

Failure to use copper conductors could result in equipment damage as the equipment was not designed or qualified to accept other types of conductors.

Knock-outs for wiring are located on the bottom right side of the control panel. The wiring is passed through these conduits and connected to the terminal blocks or HACR type breakers. See [Figure 49, p. 59](#).

To provide proper phasing of 3-phase input, make connections as shown in field wiring diagrams and as

stated on the **WARNING** label in the starter panel. Proper equipment ground must be provided to each ground connection in the panel (one for each customer-supplied conductor per phase).

The high voltage field-provided connections are made through knockouts on the right side of the panel. The low voltage connections are made through the left side of the panel ([Figure 49, p. 59](#)). Additional grounds may be required for each 115 volt power supply to the unit. Green lugs are provided for 115V customer wiring.

Control Power Supply

The unit is equipped with a control power transformer. It is not necessary to provide additional control power voltage to the unit. No other loads should be connected to the control power transformer.

All units are factory-connected for appropriate labeled voltages.

NOTICE

Evaporator Damage!

Failure to follow instructions below could result in evaporator damage.

A qualified technician must frequently verify power to the heat tape and confirm operation of the heat tape thermostat. Control panel main processor does not check for loss of power to the heat tape, nor does it verify thermostat operation.

Heater Power Supply

For units with freeze protection selected (model number digit 18 is "1"), the evaporator shell is insulated from ambient air and protected from freezing temperatures by a thermostatically-controlled immersion heaters. When the ambient temperature drops to approximately 37°F (2.8°C) the thermostat energizes the heaters. The heaters will provide protection from ambient temperatures down to -20°F (-29°C).

It is required to provide an independent power source (115V 60-Hz-20 amp, 50Hz-15 amp), with a fused-disconnect to the heaters. The heaters are factory-wired back to the unit control panel.

Note: *If evaporator is drained, the heaters must be turned off to avoid damage to the heaters or heating elements. Damaged heaters could cause risk of evaporator damage once it is back in operation. The heater should only be on when the evaporator has water (or other solution) in it.*

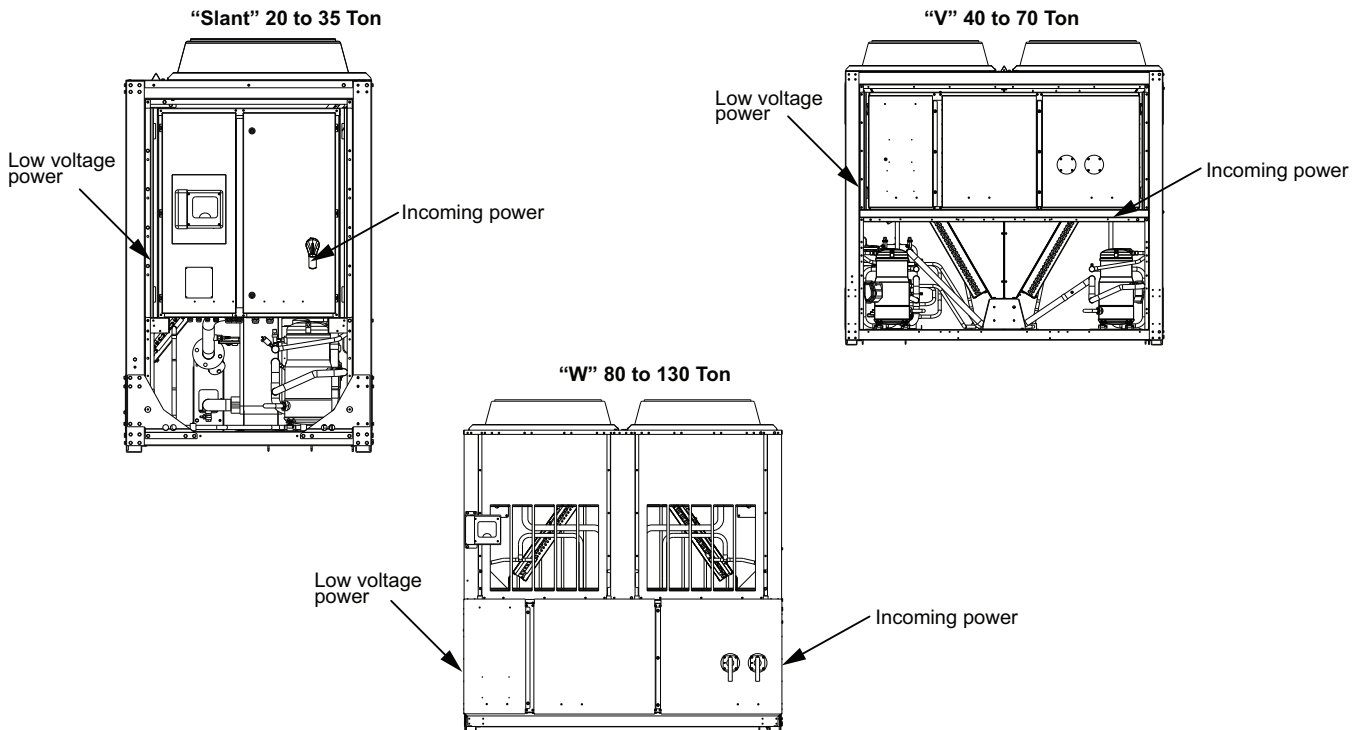
Figure 49. Power entrance

Partial Heat Recovery Power Supply

The partial heat recover heat exchanger is insulated from ambient air and protected from freezing temperatures by an immersion heater. When the ambient air temperature drops to approximately 37°F (2.8°C) the thermostat energizes the heaters. The heaters will provide protection from ambient temperatures down to -20°F (-29°C).

It is required to provide an independent power source (115V 60-Hz-20 amp, 50Hz-15 amp), with a fused-disconnect to the heater. The heaters are factory-wired back to the unit control panel.

Note: *If partial heat recovery heat exchanger is drained, the heater must be turned off in order to avoid damaging the partial heat recovery heat exchanger. The heater should only be on when the heat recovery heat exchanger has water in it.*

Water Pump Power Supply

For units without the optional pump package, provide power supply wiring with disconnect for the chilled water pump(s).

For units with the optional pump package, power is provided through a separate factory-wired control panel, integrated into the chiller unit power.

Interconnecting Wiring

Chilled Water Flow (Pump) Interlock

All CGAM model chillers have a factory-installed flow switch. In addition, it is recommended to use an additional fieldsupplied control voltage contact input through an auxiliary contact to prove flow. Connect the auxiliary contact to 1X5-3 and 1X5-9. Refer to the field wiring for details. The auxiliary contact can be a BAS signal, starter contactor auxiliary or any signal which indicates the pump is running.

Chilled Water Pump Control

An evaporator water pump output relay closes when the chiller is given a signal to go into the Auto mode of operation from any source. The contact is opened to turn off the pump in the event of most machine level diagnostics to prevent the build up of pump heat.

The relay output from 1A9 is required to operate the Evaporator Water Pump (EWP) contactor. Contacts should be compatible with 115/240 Vac control circuit. Normally, the EWP relay follows the AUTO mode of the chiller. Whenever the chiller has no diagnostics and is in the AUTO mode, regardless of where the auto command is coming from, the normally open relay is energized. When the chiller exits the AUTO mode, the relay is timed to open in an adjustable (using Tracer® TU or TD-7) 0 to 30 minutes. The non-AUTO modes in which the pump is stopped, include Stopped, Start Inhibited by External Source, Start Inhibited by BAS, Start Inhibited by Low Ambient Temp, and Ice Building complete.



NOTICE

Evaporator Damage!

If the microprocessor calls for a pump to start and water does not flow, the evaporator may be damaged catastrophically.

It is the responsibility of the installing contractor and/or the customer to ensure that a pump will always be running when called upon by the chiller controls.

Table 34. Pump relay operation

Chiller Mode	Relay Operation
Auto	Instant close
Ice Building	Instant close
Tracer® Override	Close
Stop	Timed to Open
Ice Complete	Instant Open
Diagnostics	Instant Open

When going from Stop to Auto, the EWP relay is energized immediately. If evaporator water flow is not established in 4 minutes and 15 seconds, the Symbio 800 de-energizes the EWP relay and generates a non-latching diagnostic. If flow returns (e.g. someone else is controlling the pump), the diagnostic is cleared, the EWP relay is re-energized, and normal control resumed.

If evaporator water flow is lost once it has been established, the EWP relay remains energized and a non-latching diagnostic is generated. If flow returns, the diagnostic is cleared and the chiller returns to normal operation.

NOTICE

Equipment Damage!

Failure to follow instructions below could cause equipment damage.

Do NOT enable/disable the chiller by removing water flow.

In general, when there is either a non-latching or latching diagnostic, the EWP relay is turned off as though there was a zero time delay. The relay continues to be energized with:

A Low Chilled Water Temperature diagnostic (non-latching) unless also accompanied by an Evap Leaving Water Temperature Sensor Diagnostic.

or

A Loss of Evaporator Water Flow diagnostic (non-latching) and the unit is in the AUTO mode, after initially having proven evaporator water flow.

Note: If pump control is used for freeze protection then the pump MUST be controlled by the CGAM Symbio 800 control. If another method of freeze protection is used (i.e. glycol, heaters, purge, etc) then the pump may be controlled by another system.

Chilled Water Pump Control — Field Supplied Dual Pumps

If the unit is configured for dual pump, fixed-speed operations (two Symbio 800-controlled pumps), Symbio 800 provides two normally open relay outputs (1A9), one for each pump, to command pump operation via a contactor. The control alternates pump operation for each new request for water flow. Restart during the pump off delay does not cause pump switch.

If evaporator water pump fault inputs are installed/used (1A12), Symbio 800 provides two low-voltage binary fault inputs, one for each pump. A pump fault causes the respective pump relay to de-energize. A pump fault causes a **evaporator pump X fault** diagnostic and an automatic, immediate switch to the idle pump if the idle pump does not already have an active pump fault diagnostic. If both pumps have an active pump fault diagnostic, unit operation will be prevented by a run inhibit. The run inhibit will be removed if either pumps fault diagnostic clears. A **no evap water pumps available** submode is displayed when the run inhibit is active.

In this situation, the unit will leave the factory with Evaporator Pump Control (EVPC) = No Pump Control (Pump Request Relay) (NPMP) and Evaporator Pump Fault Input (EVFI) = Installed (INST). When the contactors and pumps are set up in the field, the Tracer TU Service Tool must be used to reconfigure to Evaporator Pump Control = Dual Pump Fixed Speed and Evaporator Pump Fault Input = Not Installed or Installed depending on how the fault feedback wire is connected. It is strongly recommended to install the Fault Input if possible as the controls will hot-swap the pumps upon detection of a fault, and may avoid the inevitable Flow Loss diagnostic (and unit shutdown) that will result if there is no fault feedback.

When configured for Dual Pump Fixed Speed, the Symbio 800 will swap pumps on detection of a fault (if installed), or when a flow loss or overdue event occurs. It will also switch pumps each time the overall pump request is removed and re-engaged, unless a fault is detected on one of the pumps. If faults are detected on both pumps, the unit will be shutdown.

In addition to the factory installed flow switch, a field-supplied auxiliary contact is required, so that the chiller will only detect flow if a pump is running and the flow switch says flow is present.

Chilled Water Pump Control — Optional Pump Package

When factory installed pump package option is selected, the chiller MUST control the pumps. See "Chilled Water Pump Control," p. 59.

Alarm and Status Relay Outputs (Programmable Relays)

A programmable relay concept provides for enunciation of certain events or states of the chiller, selected from a list of

likely needs, while only using four physical output relays, as shown in the field wiring diagram. The four relays are provided (generally with a Quad Relay Output LLID) as part of the Alarm Relay Output Option. The relay's contacts are isolated Form C (SPDT), suitable for use with 120 Vac circuits drawing up to 2.8 amps inductive, 7.2 amps

resistive, or 1/3 HP and for 240 Vac circuits drawing up to 0.5 amp resistive.

The list of events/states that can be assigned to the programmable relays can be found in [Table 35, p. 61](#). The relay will be energized when the event/state occurs.

Table 35. Alarm and status relay output configuration

	Description
Alarm - Latching	This output is true whenever there is any active diagnostic that requires a manual reset to clear, that affects either the Chiller, the Circuit, or any of the Compressors on a circuit. This classification does not include informational diagnostics.
Alarm - Non-Latching	This output is true whenever there is any active diagnostic that could automatically clear, that affects either the Chiller, the Circuit, or any of the Compressors on a circuit. This classification does not include informational diagnostics.
Alarm	This output is true whenever there is any diagnostic affecting any component, whether latching or automatically clearing. This classification does not include informational diagnostics.
Maximum Capacity	This output is true whenever the chiller has all compressors on for 20 continuous minutes. This output is false once one compressor is shut off for 20 continuous minutes.
Chiller Limit Mode	This output is true whenever the chiller has been running in one of the Unloading types of limit modes (Demand Limit, Low Evaporator Pressure Limit, Condenser Pressure Limit, or Compressor Involute Pressure Limit) continuously for the last 20 minutes.
Hot Water Control	This output is true if capacity control is in Hot Water Control mode (the water temperature is being controlled to the Active Hot Water Setpoint). The output is false in any other capacity control mode (Chilled Water Control, Ice Building, etc.).
Ice Building Status	The output is true if the unit is configured for ice building, the ice building feature is enabled, there are no ice building diagnostics, and ice building has been commanded. If the unit is not running and is then commanded into ice mode, the output should turn on before the first compressor starts. The output should turn false when the ice building cycle is complete. This output may be used to interlock with valves, etc. that need to be switched over to do the ice building cycle.
Compressor Running	This output is true whenever any compressor is running (or commanded to be running) on the chiller and false when no compressors are commanded to be running on the chiller.
Evaporator Freeze Avoidance Request	This relay is true any time the Low Evaporator Water Temp (Unit Off) diagnostic is active. This relay is intended for use as an external interlock for a field engineered and provided solution to mitigate the freeze danger implied by this diagnostic.
Warning	This output is true whenever there is an active latching or non-latching informational diagnostic that targets the chiller, circuit, or any of the compressors on a circuit.
Alarm Circuit 1	This output is true whenever there is any diagnostic affecting Refrigerant Circuit 1, whether latching or automatically clearing, including diagnostics affecting the entire chiller. This classification does not include informational diagnostics.
Alarm Circuit 2	This output is true whenever there is any diagnostic affecting Refrigerant Circuit 2 whether latching or automatically clearing, including diagnostics affecting the entire chiller. This classification does not include informational diagnostics.



Installation Electrical

Table 35. Alarm and status relay output configuration (continued)

	Description
Circuit 1 Running	This output is true whenever any compressor is running (or commanded to be running) on Refrigerant Circuit 1, and false when no compressors are commanded to be running on that circuit.
Circuit 2 Running	This output is true whenever any compressor is running (or commanded to be running) on Refrigerant Circuit 2, and false when no compressors are commanded to be running on that circuit.

Relay Assignments Using Tracer® TU

Tracer TU Service Tool is used to install the Alarm and Status Relay Option package and assign any of the above list of events or status to each of the four relays provided with the option. The relays to be programmed are referred to by the relays terminal numbers on the LLID board 1A18.

The default assignments for the four available relays of the CGAM Alarm and Status Package Option are:

Table 36. Default relay assignments

Relay	
Relay 1 Terminals J2 - 12,11,10:	Compressor Running
Relay 2 Terminals J2 - 9,8,7:	Latching Alarm
Relay 3 Terminals J2-6,5,4:	Chiller Limit Mode
Relay 4 Terminals J2-3,2,1:	Warning

If any of the Alarm/Status relays are used, provide electrical power, 115 Vac with fused-disconnect to the panel and wire through the appropriate relays (terminals on 1A13. Provide wiring (switched hot, neutral, and ground connections) to the remote annunciation devices. Do not use power from the chiller's control panel transformer to power these remote devices. Refer to the field diagrams which are shipped with the unit.

Low Voltage Wiring

⚠ WARNING

Proper Field Wiring and Grounding Required!

Failure to follow code could result in death or serious injury.

All field wiring **MUST** be performed by qualified personnel. Improperly installed and grounded field wiring poses **FIRE** and **ELECTROCUTION** hazards. To avoid these hazards, you **MUST** follow requirements for field wiring installation and grounding as described in **NEC** and your local/state/national electrical codes.

The remote devices described below require low voltage wiring. All wiring to and from these remote input devices to the Control Panel must be made with shielded, twisted pair conductors. Be sure to ground the shielding only at the panel.

Note: To prevent control malfunctions, do not run low voltage wiring (<30 V) in conduit with conductors carrying more than 30 volts.

Emergency Stop

Symbio 800 provides auxiliary control for a customer specified/ installed latching trip out. When this customer-furnished remote contact 6K5 is provided, the chiller will run normally when the contact is closed. When the contact opens, the unit will trip on a manually resettable diagnostic. This condition requires manual reset at the chiller switch on the front of the control panel.

Connect low voltage leads to terminal strip locations on 1A13, J2-3 and 4. Refer to the field diagrams that are shipped with the unit.

Silver or gold-plated contacts are recommended. These customer-furnished contacts must be compatible with 24 Vdc, 12 mA resistive load.

External Auto/Stop

If the unit requires the external Auto/Stop function, the installer must provide leads from the remote contact 6K4 to the proper terminals on 1A13, J2-1 and 2.

The chiller will run normally when the contact is closed. When the contact opens, the compressor(s), if operating, will go to the RUN:UNLOAD operating mode and cycle off. Unit operation will be inhibited. Closure of the contact will permit the unit to return to normal operation.

Field-supplied contacts for all low voltage connections must be compatible with dry circuit 24 Vdc for a 12 mA resistive load. See the field diagrams that are shipped with the unit.

NOTICE

Equipment Damage!

Failure to follow instructions below could cause equipment damage.

Do NOT enable/disable the chiller by removing water flow.

Ice Building Option

Symbio 800 provides auxiliary control for a customer specified/ installed contact closure for ice building if so configured and enabled. This output is known as the Ice Building Status Relay. The normally open contact will be closed when ice building is in progress and open when ice building has been normally terminated either through Ice

Termination setpoint being reached or removal of the Ice Building command. When contact 6K6 is provided, the chiller will run normally when the contact is open.

Symbio 800 will accept either an isolated contact closure (External Ice Building command) or a Remote Communicated input (Tracer®) to initiate and command the Ice Building mode.

Symbio 800 also provides a “Ice Termination Setpoint”, settable through Tracer TU or TD-7, and adjustable from 20 to 31°F (-6.7 to -0.5°C) in at least 1°F (1°C) increments.

When in the Ice Building mode, and the evaporator entering water temperature drops below the ice termination setpoint, the chiller terminates the Ice Building mode and changes to the Ice Building Complete mode.

NOTICE

Equipment Damage!

Failure to follow instructions could result in damage to system components.

Freeze inhibitor must be adequate for the leaving water temperature.

Tracer TU or TD-7 may also be used to enable or disable Ice Building Control. This setting does not prevent the Tracer from commanding Ice Building mode.

Upon contact closure, the Symbio 800 will initiate an ice building mode, in which the unit runs fully loaded at all times. Ice building shall be terminated either by opening the contact or based on the entering evaporator water temperature. Symbio 800 will not permit the ice building mode to be reentered until the unit has been switched out of ice building mode (open 5K20 contacts) and then switched back into ice building mode (close 5K20 contacts.)

In ice building, all limits (freeze avoidance, evaporator, condenser, current) will be ignored. All safeties will be enforced.

If, while in ice building mode, the unit gets down to the freeze stat setting (water or refrigerant), the unit will shutdown on a manually resettable diagnostic, just as in normal operation.

Connect leads from 6K6 to the proper terminals of 1A16. Refer to the field diagrams which are shipped with the unit.

Silver or gold-plated contacts are recommended. These customer furnished contacts must be compatible with 24 Vdc, 12 mA resistive load.

External Chilled Water Setpoint (ECWS) Option

The Symbio 800 provides inputs that accept either 4-20 mA or 2-10 Vdc signals to set the external chilled water setpoint (ECWS). **This is not a reset function.** The input defines the set point. This input is primarily used with generic BAS (building automation systems). The chilled water setpoint set via the Tracer TU or TD-7 or through digital communication with Tracer®.

The chilled water setpoint may be changed from a remote location by sending either a 2-10 Vdc or 4-20 mA signal to the 1A14, J2-1 and 2. The 2-10 Vdc and 4-20 mA each correspond to a 10 to 65°F (-12 to 18°C) external chilled water setpoint.

The following equations apply:

Voltage Signal

Vdc =

$$(8 * ECWS_{\circ F} + 2 * ECWS_{max} - 10 * ECWS_{min}) / (ECWS_{max} - ECWS_{min})$$

Current Signal

mA =

$$(16 * ECWS_{\circ F} + 4 * ECWS_{max} - 20 * ECWS_{min}) / (ECWS_{max} - ECWS_{min})$$

Note: To convert ECWS values to °F, use the following formula: °F = 1.8*(°C) + 32

If the ECWS input develops an open or short, the LLID will report either a very high or very low value back to the main processor. This will generate an informational diagnostic and the unit will default to using the Front Panel (TD-7) Chilled Water Setpoint.

Tracer TU Service Tool is used to set the input signal type from the factory default of 2-10 Vdc to that of 4-20 mA.

Tracer TU is also used to install or remove the External Chilled Water Setpoint option as well as a means to enable and disable ECWS.

External Demand Limit Setpoint (EDLS) Option

Symbio 800 provide a means to limit the capacity of the chiller by limiting the number of compressors or stages that are allowed to run. The maximum number of compressor or stages allowed to run can vary from one to the number of stages on the unit. The staging algorithm is free to decide which compressor or stage shall be turned off or prevented from running to meet this requirement.

Symbio 800 shall accept either a 2-10 Vdc or 4-20 mA analog input suitable for customer connection to set the unit external demand limit setpoint (EDLS).

2-10 Vdc and 4-20 mA shall each correspond to an EDLS range with a minimum of 0 percent and a maximum of 100 percent. The following equations exist.

	Voltage Signal	Current Signal
As generated from external source	Vdc = 8*(EDLS) + 2	mA = 16*(EDLS) + 4
As processed by Symbio 800	EDLS = (Vdc - 2)/8	EDLS = (mA - 4)/16

The minimum EDLS will be clamped at the front panel based on 100% / Total number of Compressors. For input signals beyond the 2-10 Vdc or 4-20 mA range, the end of range value shall be used. For example, if the customer

inputs 21 mA, the EDLS shall limit it self to the corresponding 20 mA EDLS.

ECWS and EDLS Analog Input Signal Wiring Details

Both the ESWS and EDLS can be connected and setup as either a 2-10 Vdc (factory default), 4-20 mA, or resistance input (also a form of 4-20 mA) as indicated below. Depending on the type to be used, the Tracer TU Service Tool must be used to configure the LLID and the MP for the proper input type that is being used. This is accomplished by a setting change on the Custom Tab of the Configuration View within Tracer TU.

The J2-3 and J2-6 terminal is chassis grounded and terminal J2-1 and J2-4 can be used to source 12 Vdc. The ECLS uses terminals J2-2 and J2-3. EDLS uses terminals J2-5 and J2-6. Both inputs are only compatible with high-side current sources.

Figure 50. Wiring examples for ECLS and EDLS

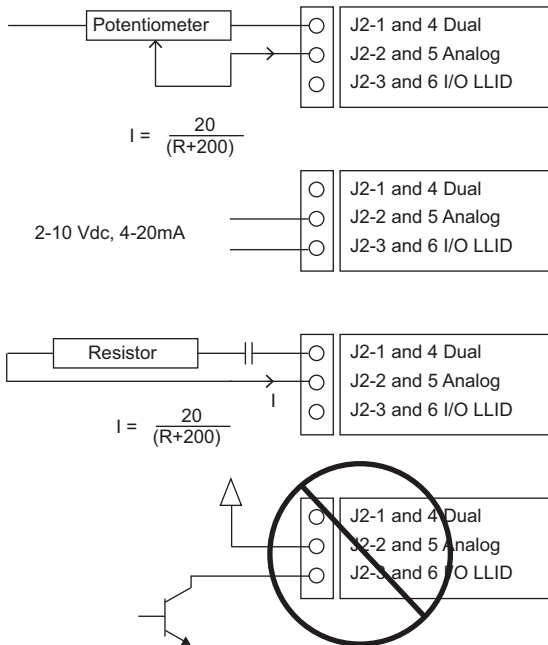

Chilled Water Reset (CWR)

Symbio 800 resets the chilled water temperature setpoint based on either return water temperature, or outdoor air temperature.

The following shall be selectable:

- One of three Reset types: None, Return Water Temperature Reset, Outdoor Air Temperature Reset, or Constant Return Water Temperature Reset.
- Reset Ratio setpoints.
- For outdoor air temperature reset there shall be both positive and negative reset ratios.
- Start Reset Setpoints.

- Maximum Reset setpoints.

The equations for each type of reset are as follows:

Return

$CWS' = CWS + RATIO (START\ RESET - (TWE - TWL))$

and $CWS' > or = CWS$

and $CWS' - CWS < or = Maximum\ Reset$

Outdoor

$CWS' = CWS + RATIO * (START\ RESET - TOD)$

and $CWS' > or = CWS$

and $CWS' - CWS < or = Maximum\ Reset$

where

CWS' is the new chilled water set point or the "reset CWS"

CWS is the active chilled water set point before any reset has occurred, e.g. normally Front Panel, Tracer®, or ECWS

RESET RATIO is a user adjustable gain

START RESET is a user adjustable reference

TOD is the outdoor temperature

TWE is entering evap. water temperature

TWL is leaving evap. water temperature

MAXIMUM RESET is a user adjustable limit providing the maximum amount of reset. For all types of reset,

$CWS' - CWS < or = Maximum\ Reset.$

Reset Type	Reset Ratio Range	Start Reset Range	Maximum Reset Range	Increment		Factory Default Value
				IP	SI	
Return	10-120%	4-30°F	0-20°F	1%	1%	50%
		(2.2-16.7°C)	(0.0-11.1°C)			
Outdoor	80--80%	50 - 130°F	0 - 20°F	1%	1%	50%
		(10-54.4°C)	(0.0-11.1°C)			

In addition to Return and Outdoor Reset, the MP provides a menu item for the operator to select a Constant Return Reset. Constant Return Reset will reset the leaving water temperature set point so as to provide a constant entering water temperature. The Constant Return Reset equation is the same as the Return Reset equation except on selection of Constant Return Reset, the MP will automatically set Ratio, Start Reset, and Maximum Reset to the following.

RATIO = 100%

START RESET = Design Delta Temp.

MAXIMUM RESET = Design Delta Temp.

The equation for Constant Return is then as follows:

$CWS' = CWS + 100% (Design\ Delta\ Temp. - (TWE - TWL))$

and $CWS' > or = CWS$

and CWS' - CWS < or = Maximum Reset

When any type of CWR is enabled, the MP will step the Active CWS toward the desired CWS' (based on the above equations and setup parameters) at a rate of 1 degree F every 5 minutes until the Active CWS equals the desired CWS'. This applies when the chiller is running.

When the chiller is not running the CWS is reset immediately (within one minute) for Return Reset and at a rate of 1 degree F every 5 minutes for Outdoor Reset. The chiller will start at the Differential to Start value above a fully reset CWS or CWS' for both Return and Outdoor Reset.

Percent Capacity Output Option

Symbio 800 provides an optional percent capacity output for those customers without a communicating BAS interface. The active unit capacity (AUC) is provided through a 2-10 Vdc analog output at 1A25 terminals J2-4 and J2-6 (GND). The active unit capacity value (in%) can be derived from the 2-10 Vdc output voltage (OV) using the following calculation:

$$AUC = 100 * (OV - 2.0V) / (10.0V - 2.0V)$$

Note: *The percent capacity output is based on the number and size of compressors energized, and is not adjusted for operating conditions. This value cannot be used as an accurate measure of total unit current, power or cooling capacity.*

Communications Interface

LonTalk Interface (LCI-C)

The LonTalk communication protocol for the Symbio 800 controller expands communications from the unit UCM

network to a Tracer Ensemble™ building automation system or third party building automation system. Utilizing LonTalk, the BAS allows external setpoint and configuration adjustment and monitoring of status and diagnostics. The Symbio 800 utilizes an FTT-10A free topology transceiver, which supports non-polarity sensitive, free topology wiring – which in turn allows the system installer to utilize star, bus, and loop architectures. This controller works in standalone mode, peer-to-peer with one or more other units, or when connected to a Tracer Ensemble, Tracer SC+, or a third party building automation system that supports LonTalk.

BACnet Interface (BCI-C)

The BACnet control network for Symbio 800 expands communications from the unit UCM network to the Tracer Ensemble or Tracer SC+ building automation system or third party building automation system. Utilizing BACnet, the BAS allows external setpoint and configuration adjustment and monitoring of status and diagnostics. The Symbio 800 utilizes the BACnet defined MS/TP protocol as defined in ASHRAE standard 135-2004. This controller works in standalone mode, with Tracer Ensemble, Tracer SC+ or when connected to a third party building automation system that supports BACnet.

Modbus® Remote Terminal Unit Interface

Allows the user to easily interface with Modbus RTU communication protocol via a single twisted pair wiring from the Symbio 800 controller to a factory installed device.



Operating Principles

This section contains an overview of the operation of CGAM air-cooled liquid chiller equipped with microcomputer-based control systems. It describes the overall operating principles of the CGAM water chiller.

Note: To ensure proper diagnosis and repair, contact a qualified service organization if a problem could occur.

General

The Model CGAM units are scroll compressor air-cooled liquid chillers. These units are equipped with unit-mounted starter/ control panels and operates with R-410A or R-454B refrigerant.

The basic components of an CGAM unit are:

- Unit-mounted panel containing starter and Tracer Symbio 800 controller , TD-7 Display, and Input/Output LLIDS
- Scroll compressors
- Brazed plate evaporator
- Air-cooled condenser with subcooler
- Electronic Expansion Valve
- Optional partial heat recovery
- Relating interconnecting piping

Components of a typical CGAM unit are identified in the following diagrams.

Base Units

Figure 51. Slant 20 to 35 ton component location

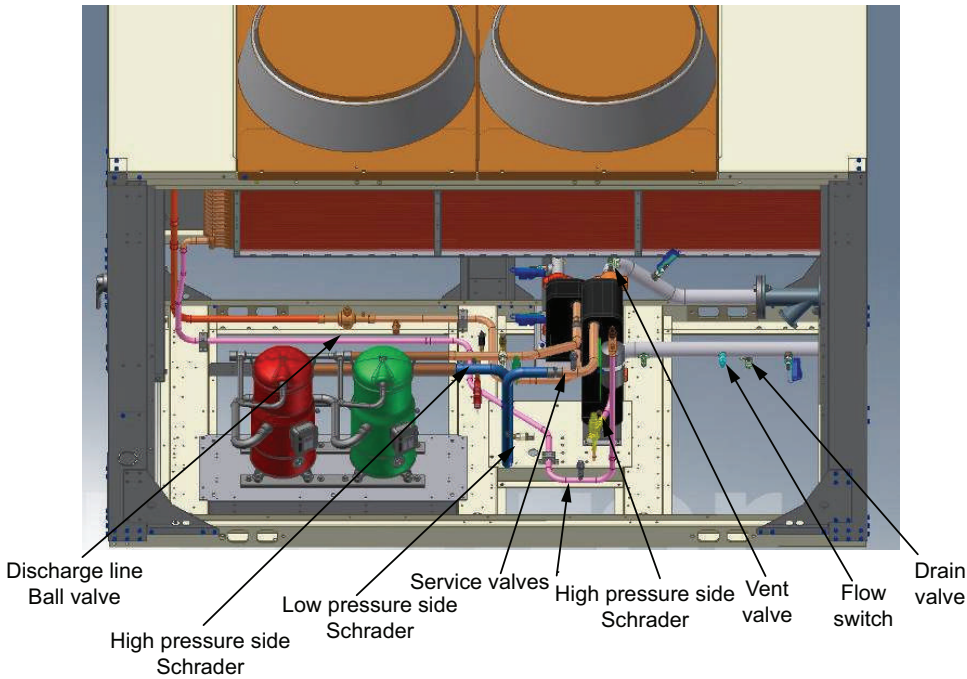

Figure 52. V 40 to 70 ton component location, circuit 1

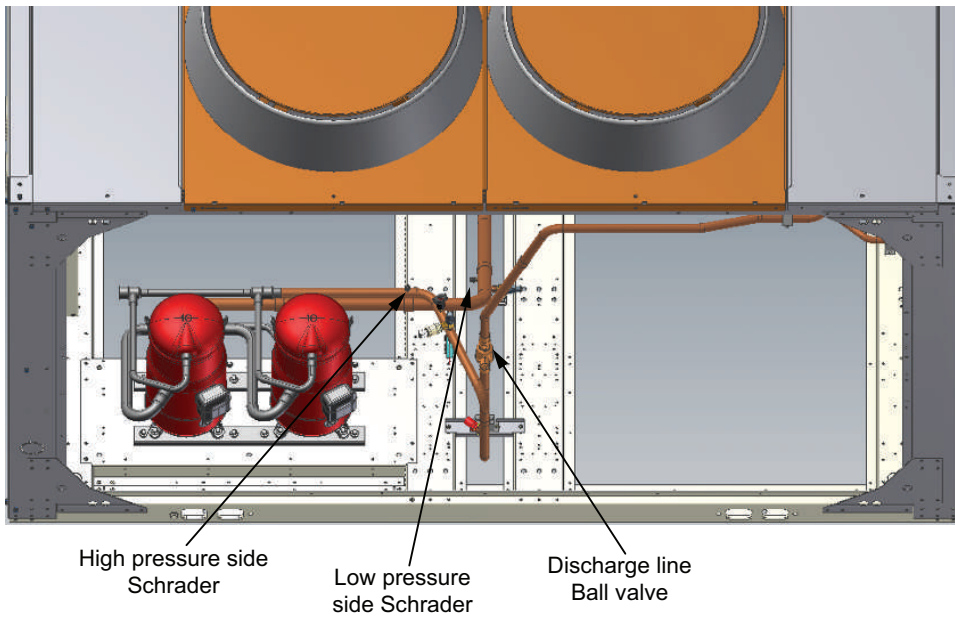

Figure 53. V 40 to 70 ton component location, circuit 2

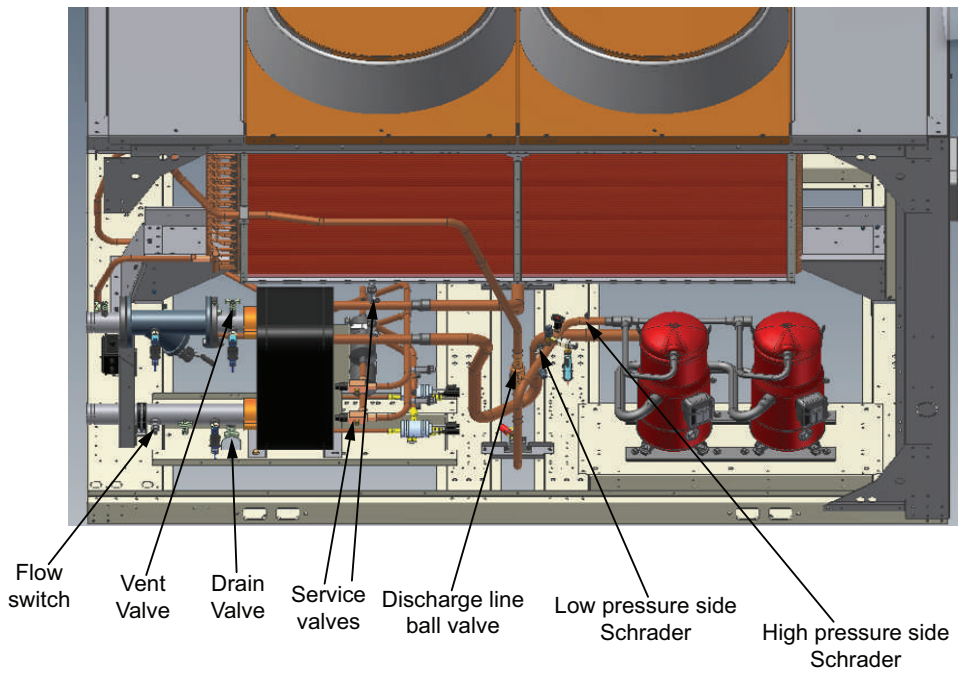

Figure 54. W 80 to 130 ton component location, compressor view

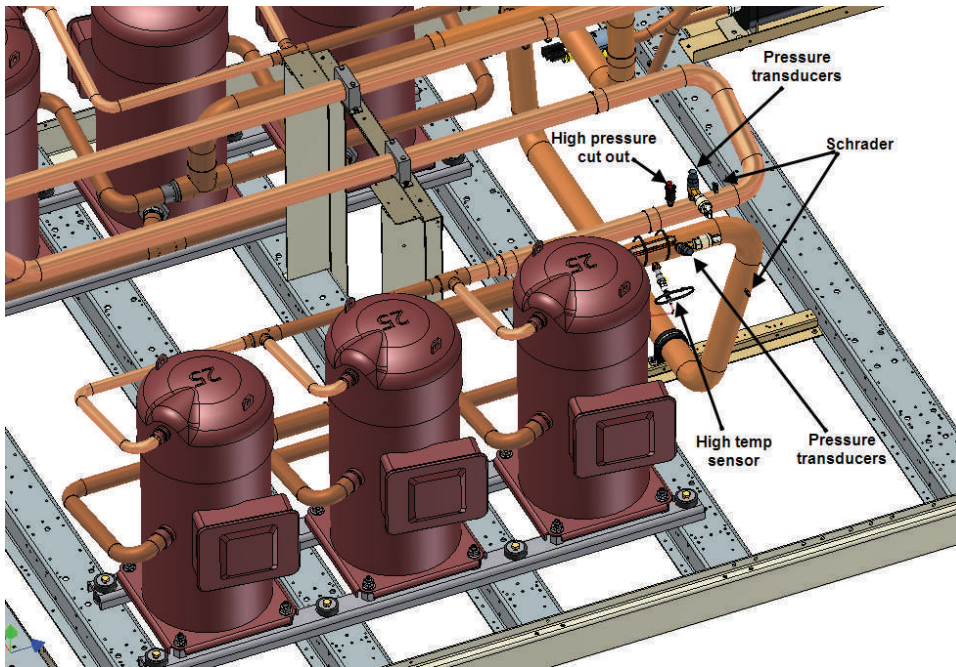
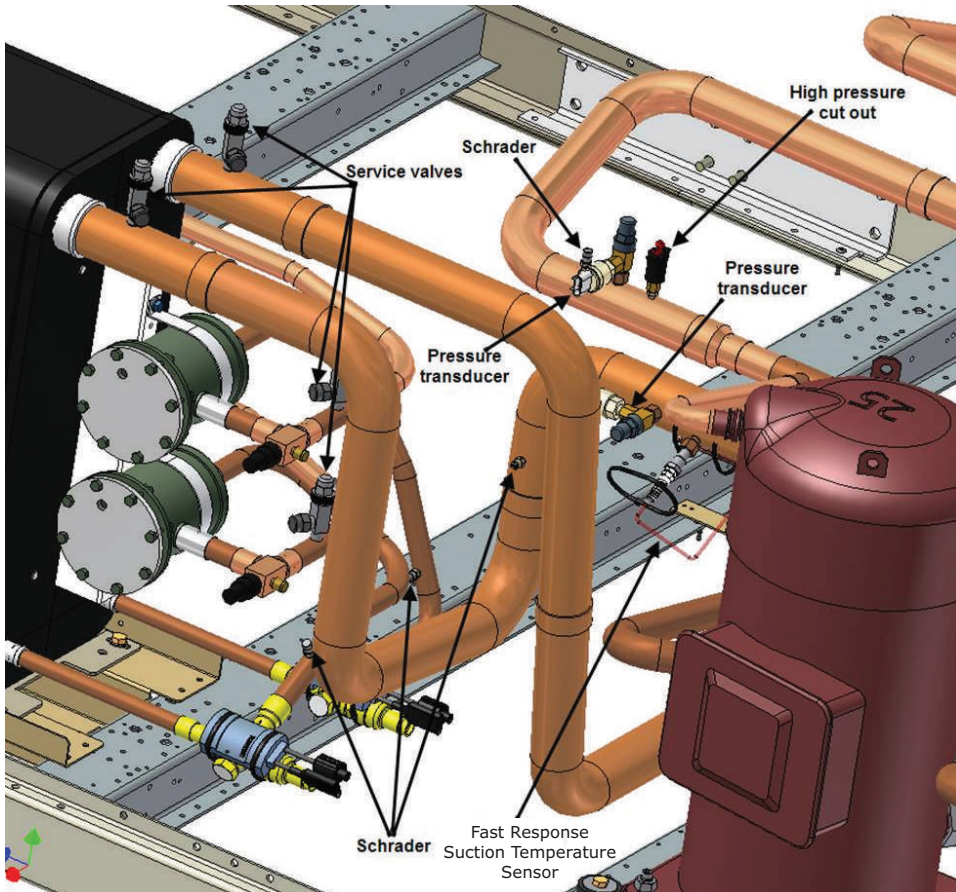

Figure 55. W 80 to 130 ton component location, evaporator side



Pump Package Components - Optional

Figure 56. Pump package components, slant 20 to 35 ton, view 1

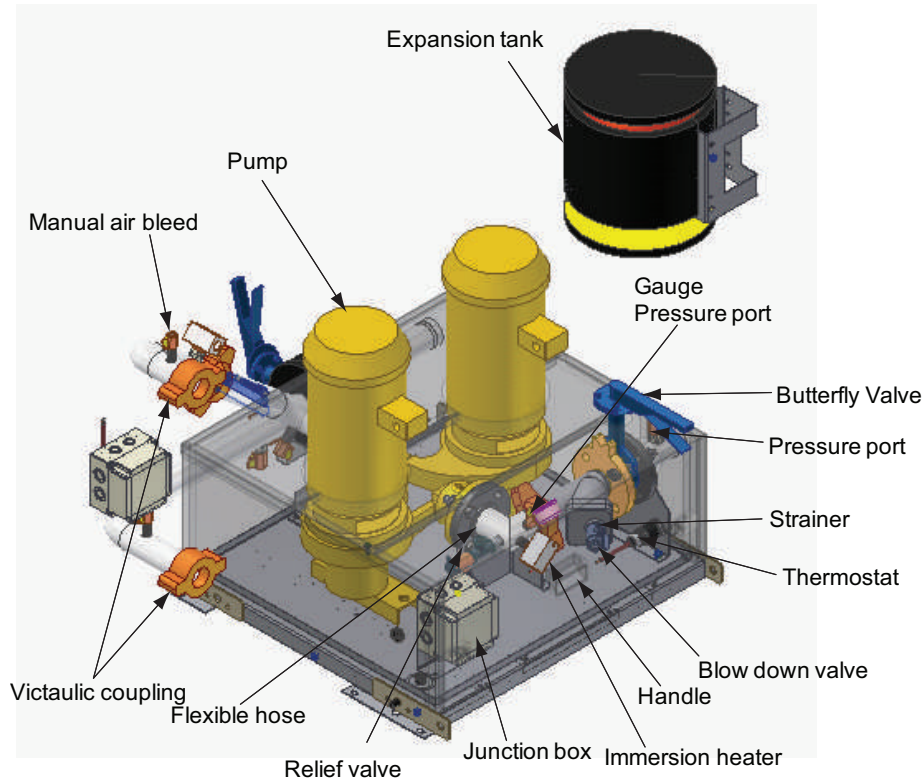

Figure 57. Pump package components, slant 20 to 35 ton, view 2

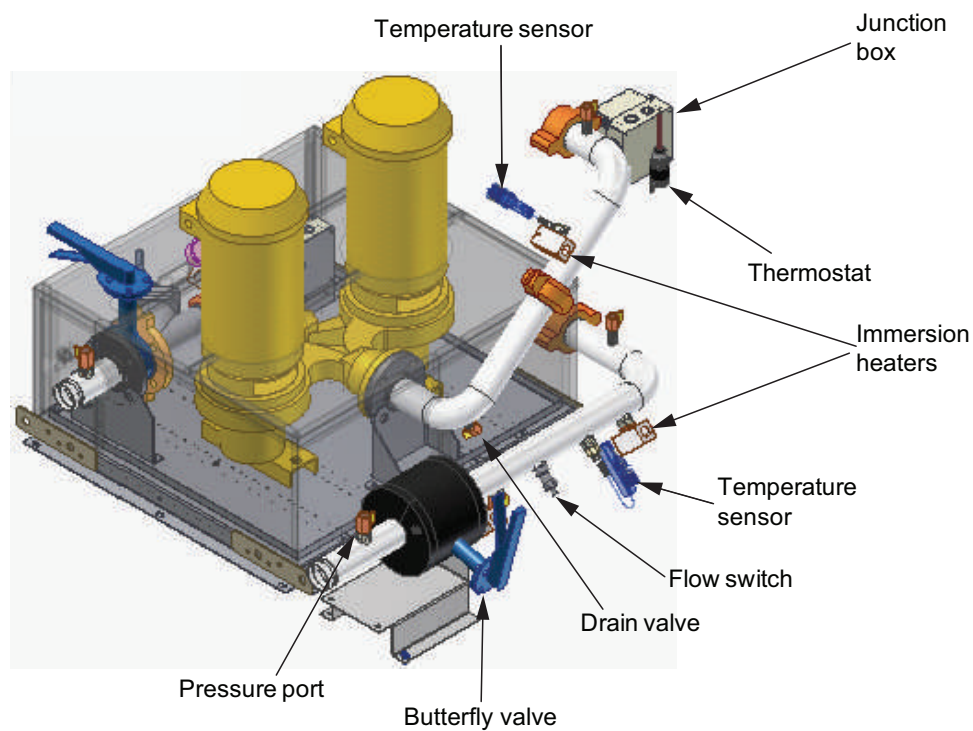

Figure 58. Pump package components, V 40 to 70 ton, view 1

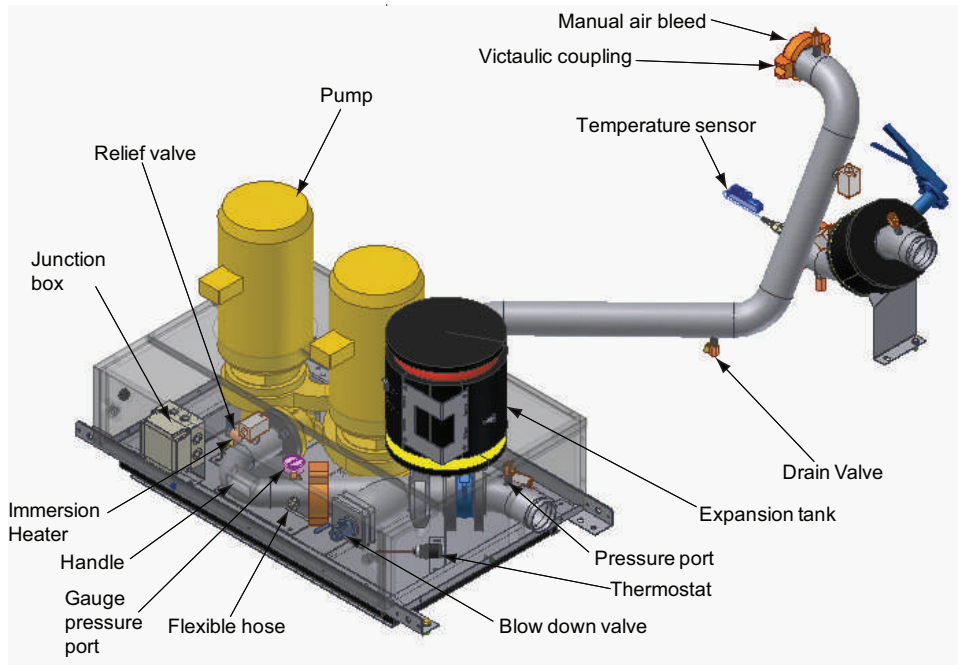

Figure 59. Pump package components, V 40 to 70 ton, view 2

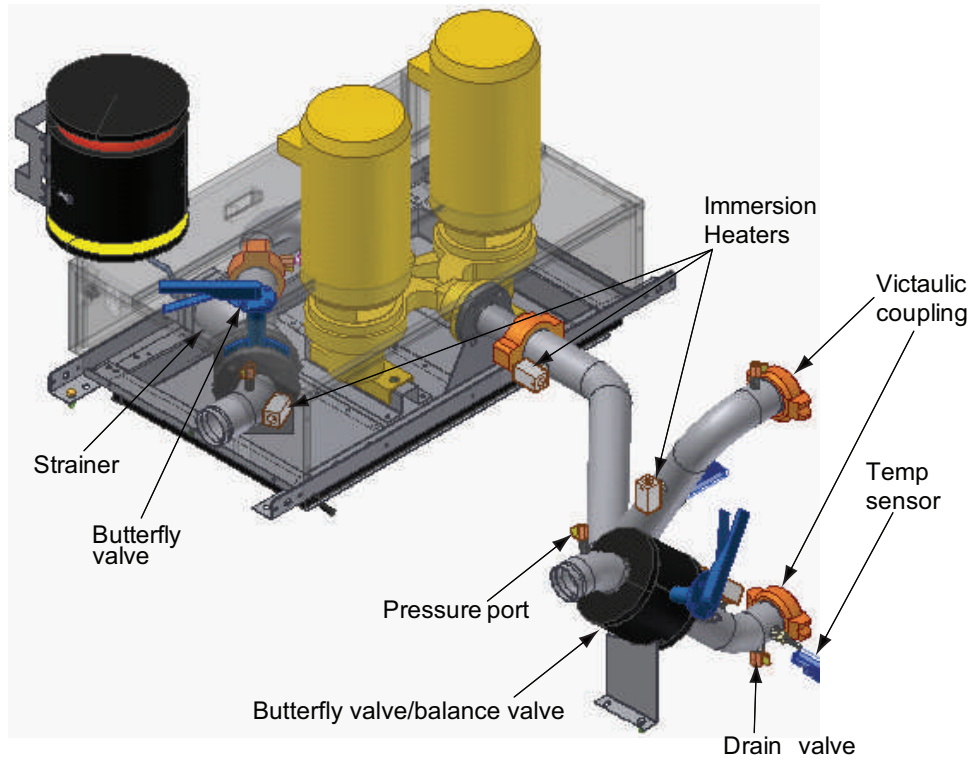

Figure 60. Pump package components, V 40 to 70 ton, view 3

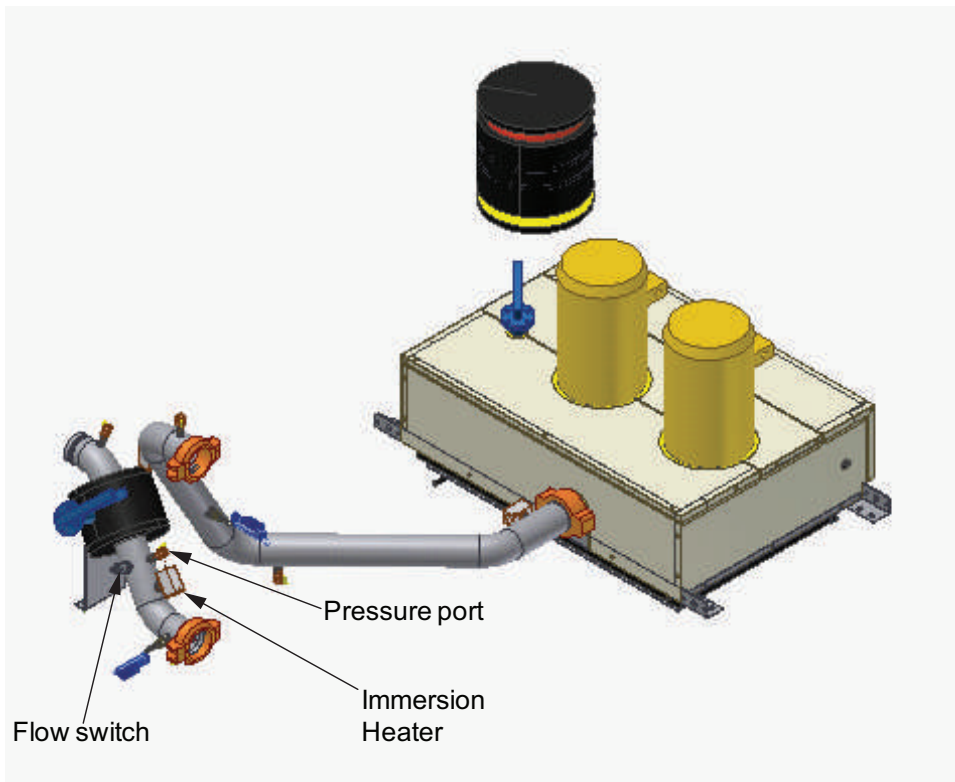

Figure 61. Pump package components, W 80 to 130 ton, view 1

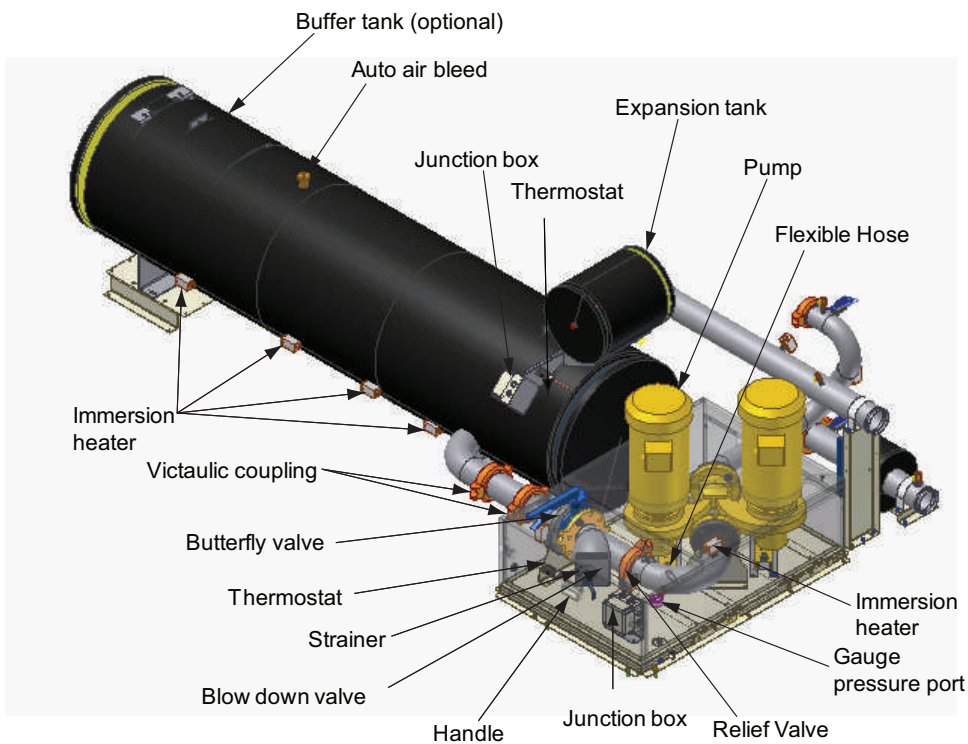
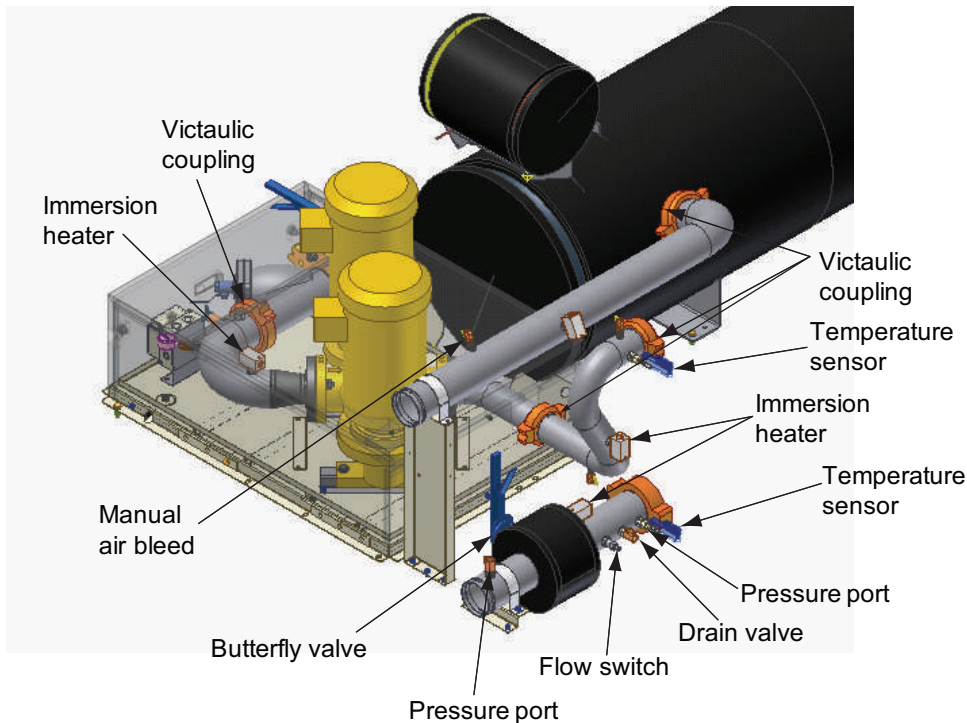

Figure 62. Pump package components, W 80 to 130 ton, view 2

Refrigerant Cycle

The refrigeration cycle of the Model CGAM chiller is conceptually similar to other Trane air-cooled chiller products. The CGAM chiller uses a brazed plate evaporator and an aircooled condenser. The compressors use suction gas cooled motors and an oil management system to provide almost oilfree refrigerant to the condenser and evaporator for maximum heat transfer while lubricating and sealing compressor bearings. The lubrication system helps to assure long compressor life and contributes to quiet operation.

Refrigerant condensers in the air-cooled heat exchanger which is available in three configurations—slant, V and W — based on the CGAM nominal tonnage cooling capacity. Liquid refrigerant is metered into the brazed plate evaporator using an electronic expansion valve to maximize chiller efficiency at full and part load operation.

The CGAM chiller is equipped with a unit-mounted starter and control panel. Microprocessor-based unit control modules (Trane Tracer® Symbio 800) provide accurate chilled water control and provide monitoring, protection and adaptive limit functions. The adaptive nature of the controls intelligently prevent the chiller from operating outside of its limits, or compensates for unusual operating conditions while keeping the chiller running rather than simply shutting off the chiller. If problems do occur, the Symbio 800 controls provide diagnostic messages to help the operator in troubleshooting.

Refrigerant Cycle Description

The CGAM refrigeration cycle is described using the pressure enthalpy chart shown in [Figure 63, p. 73](#). Key State Points 1 through 5 are indicated on the chart. A schematic showing refrigerant components throughout the system is shown in [Figure 63, p. 73](#).

Refrigerant evaporation occurs in the brazed plate evaporator. Metered refrigerant vaporizes as it cools the chilled water or liquid flowing through the evaporator passages. The refrigerant vapor leaves the evaporator as superheated gas. State Point 1.

Refrigerant vapor generated in the evaporator flows to the compressor suction manifold where it enters and flows across the compressor motor windings to provide cooling. The vapor is then compressed in the compressor scroll chambers and discharged. Oil from the compressor sump lubricates the bearings and seals the small clearances between the compressor scrolls. Refrigerant vapor is discharged to the aircooled condenser at State Point 2.

After the refrigerant vapor condenses into liquid (State Points 3 and 4) it is returned to the evaporator (State Point 5) where the refrigerant again flashes into vapor and the refrigeration cycle repeats.

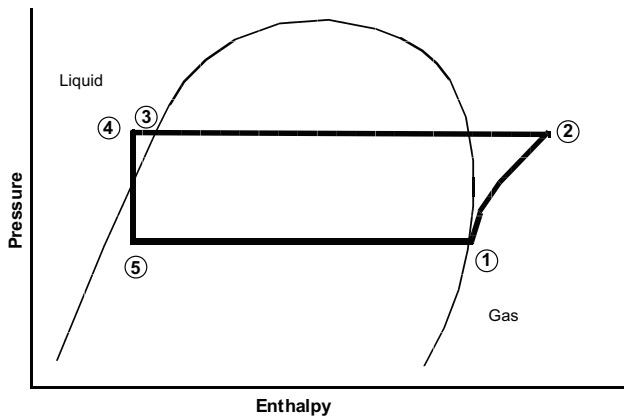
Figure 63. Pressure/enthalpy curve

Oil System Operation (CGAM)

The oil is efficiently separated inside the scroll compressor and will remain in the scroll compressor during all run cycles. Between 1-2% of the oil circulates around with the refrigerant.

Sensor Requirements

Discharge temperature sensor is required for units with the following options:

- Low Temperature Process (model number digit 21 = B)
- Ice-Making (model number digit 21 = C)
- Low Leaving Water (model number digit 21 = D)
- Heat Pump (applicable only to units built in Epinal)



Controls

Overview

CGAM units use the following control/ interface components:

- Symbio™ 800 Controller
- Tracer® AdaptiView™ TD-7 Operator Interface

Symbio 800

The Symbio 800 controller is a factory-installed, application specific and programmable controller designed to control chillers and large packaged HVAC equipment. A 7 inch user interface features a touch-sensitive color screen that provides facility managers at-a-glance operating status, performance monitoring, scheduling changes, and operating adjustments. Other advanced features include automated controller back-up, and optional features such as secure remote connectivity, wireless building communications, mobile device connectivity, and custom programming with an expandable I/O.

For more information, see *Symbio™ 800 Controller Installation, Operation, and Maintenance Manual* (BAS-SVX080*-EN).

AdaptiView Display

Information is tailored to operators, service technicians, and owners. When operating a chiller, specific information is needed on a day-to-day basis-setpoints, limits, diagnostic information, and reports. This information is provided through the AdaptiView display. Logically organized groups of information- chiller modes of operation, active diagnostics, settings and reports put information conveniently at your fingertips.

For more information, see *Adaptiview™ Display with Symbio Controls Air-Cooled CGAM Scroll Chillers User Guide* (CG-SVU011*-EN).

Tracer TU

The AdaptiView TD-7 operator interface allows for daily operational tasks and setpoint changes. However, to adequately service chillers, Tracer TU service tool is required. (Non-Trane personnel, contact your local Trane office for software purchase information.) Tracer TU adds a level of sophistication that improves service technician effectiveness and minimizes chiller downtime. This portable PC-based service-tool software supports service and maintenance tasks, and is required for software upgrades, configuration changes and major service tasks.

Tracer TU serves as a common interface to all Trane chillers, and will customize itself based on the properties of the chiller with which it is communicating. Thus, the service technician learns only one service interface.

The panel bus is easy to troubleshoot using LED sensor verification. Only the defective device is replaced. Tracer TU can communicate with individual devices or groups of devices.

All chiller status, machine configuration settings, customizable limits, and up to 100 active or historic diagnostics are displayed through the service-tool software interface.

LEDs and their respective Tracer TU indicators visually confirm the availability of each connected sensor, relay, and actuator.

Tracer TU is designed to run on a customer's laptop, connected to the Symbio 800 control panel with a USB cable. Your laptop must meet the following hardware and software requirements:

- 1 GB RAM (minimum)
- 1024 x 768 screen resolution
- CD-ROM drive
- Ethernet 10/100 LAN card
- An available USB 2.0 port
- Windows 7 Enterprise or Professional operating system (32-bit or 64-bit)

Note: *Tracer TU versions 8.6 and earlier will also support Microsoft® Windows® XP Professional operation system with Service Pack 3 (SP3) .*

- Microsoft .NET Framework 4.0 or later

Notes:

- *Tracer TU is designed and validated for this minimum laptop configuration. Any variation from this configuration may have different results. Therefore, support for Tracer TU is limited to only those laptops with the configuration previously specified.*
- *For more information, see Tracer TU Getting Started Guide (TTU-SVN01*-EN).*

Figure 64. Tracer TU

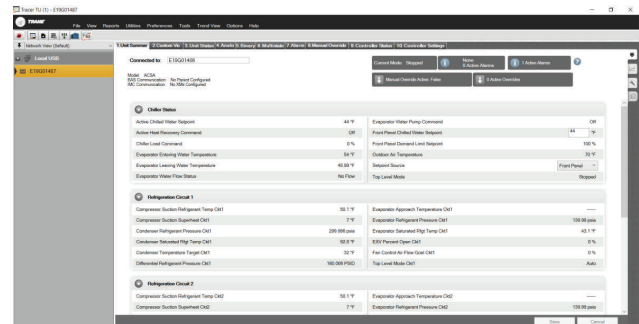



Pre-Start Checkout

Upon completion of installation, complete the CGAM Installation Completion Check Sheet and Request for Trane Service checklist in chapter “[Log and Check Sheet](#),” p. 96.

Important: *Start-up must be performed by Trane or an agent of Trane specifically authorized to perform start-up and warranty of Trane products. Contractor shall provide Trane (or an agent of Trane specifically authorized to perform start-up) with notice of the scheduled start-up at least two weeks prior to the scheduled start-up.*



Start-Up and Shutdown

Important: Initial unit commissioning start-up must be performed by Trane or an agent of Trane specifically authorized to perform start-up and warranty of Trane products. Contractor shall provide Trane (or an agent of Trane specifically authorized to perform start-up) with notice of the scheduled start-up at least two weeks prior to the scheduled start-up.

Start-Up

NOTICE

Equipment Damage!

Failure to follow instructions could result in equipment damage.

Ensure that the compressor and oil sump heaters have been operating properly for a minimum of 24 hours before starting.

NOTICE

Equipment Damage!

Snow, ice, or debris build up on fans could cause excessive imbalance and equipment damage.

Clear fans of build up prior to machine start-up.

If required, once the system has been operating for approximately 30 minutes and has become stabilized, complete the remaining start-up procedures, as follows:

1. Check the evaporator refrigerant pressure and the condenser refrigerant pressure under Refrigerant Report on the Tracer TU.
Note: The pressures are referenced to sea level (14.6960 psia). This value is adjustable in Tracer TU.
2. Check the EXV sight glasses after sufficient time has elapsed to stabilize the chiller. The refrigerant flow past the sight glasses should be clear. Bubbles in the refrigerant indicate either low refrigerant charge or excessive pressure drop in the liquid line or a stuck open expansion valve. A restriction in the line can sometimes be identified by a noticeable temperature differential between the two sides of the restriction. Frost will often form on the line at this point. Proper refrigerant charges are shown in General Data tables.

Important: A clear sight glass alone does not mean that the system is properly charged. Also check system subcooling, liquid level control and unit operating pressures.

If chiller is limited by any limiting conditions, contact local Trane service organization for more information.

Seasonal Unit Start-Up Procedure

1. Verify/close all drain valves.
2. Service the auxiliary equipment according to the start-up/ maintenance instructions provided by the respective equipment manufacturers.
3. Remove all air from the system (including each pass). Close the vents in the evaporator chilled water circuits.
4. Open all valves in evaporator chilled water circuits.
5. If evaporator was previously drained, vent and fill evaporator and chilled water circuit. When all air is removed (including each pass), install vent plugs in evaporator water boxes.

NOTICE

Equipment Damage!

Failure to follow instructions could result in equipment damage.

Ensure that the compressor and oil sump heaters have been operating properly for a minimum of 24 hours before starting.

Seasonal Unit Shutdown

1. Perform normal unit stop sequence using <Stop> key.
Note: Starter disconnect switch must remain closed to provide power to compressor oil sump heaters.
2. Verify that compressor oil sump heaters are installed tightly around compressor. Energize and verify heaters are operational using a temperature probe. See [Table 37, p. 77](#). Install jumper across thermostat and verify current flow.

NOTICE

Heater Damage!

Failure to follow instructions below could cause equipment damage.

De-energize evaporator immersion heater and/or any associated evaporator water piping immersion heaters when draining evaporator or evaporator water piping.

Table 37. Freeze protection heater summary

Heater	Thermostat	Jumper	Heater Description	Heaters
Evap and Water Pipe Heaters	5S1	5X1-2 to 5X1-3	Evaporator	5E1
			Evap Entering Water	5E4, 5E18
			Evap Leaving Water	5E5, 5E19
			Water Pump Piping	5E6, 5E14
			Partial Heat Recovery (optional)	5E10, 5E11, 5E16, 5E17
			Expansion Tank (included with optional pump package)	5E7
Pump Package (optional)	5S2	5X2-1 to 5X2-2	Water Pump Piping	5E13, 5E15
Buffer Tank (optional)	5S3	Across thermostat	Buffer Tank	5E2, 5E8, 5E12, 5E13

Note: Not all heaters are present on all unit configurations. See schematics and component locations in CGAM-SVE01*-EN.

Note: See “Ambient Freeze Avoidance,” p. 44 for more information.

- Once the unit is secured, perform maintenance identified in “Maintenance,” p. 81.

Sequence of Operation

This section provides basic information on chiller operation for common events. Adaptive control algorithms are used on these chillers. This section illustrates common control sequences.

Software Operation Overview

The following figure is a diagram of the five possible software states. This diagram can be thought of as a state chart, with the arrows and arrow text, depicting the transitions between states:

- The text in the circles is the internal software designations for each state.
- The shading of each software state circle corresponds to the shading on the time lines that show the chiller’s state.

There are five generic states that the software can be in:

- Power Up
- Stopped
- Starting
- Running
- Stopping

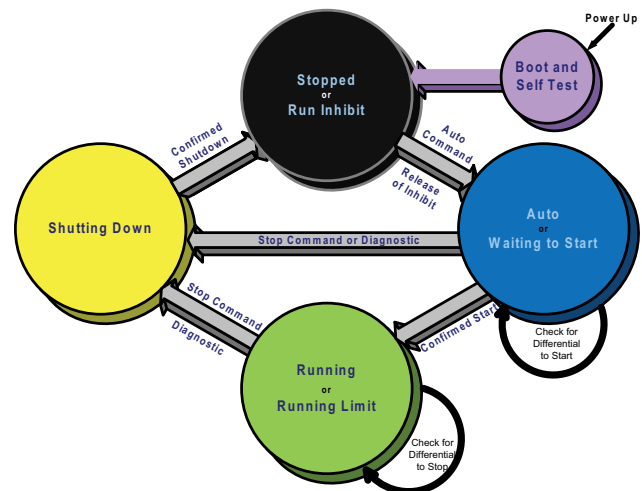

In the following diagrams:

- The time line indicates the upper level operating mode, as it would be viewed in the Tracer® AdaptiView™.
- The shading color of the cylinder indicates the software state.
- Text in parentheses indicates sub-mode text as viewed in the Tracer AdaptiView.
- Text above the time line cylinder is used to illustrate inputs to the Symbio 800. This may include user input to the Tracer AdaptiView touch screen, control inputs from sensors, or control inputs from a generic BAS.
- Boxes indicate control actions such as turning on relays, or pulsing compressor load or unload solenoids.
- Smaller cylinders under the main cylinder indicate diagnostic checks.
- Text outside a box or cylinder indicates time-based functions.
- Solid double arrows indicate fixed timers.
- Dashed double arrows indicate variable timers.

Power Up Diagram

The following diagram shows the respective TD-7 AdaptiView™ screens during a power up of the Symbio 800 and display. This process takes 15 seconds for the Symbio 800 and 105 seconds for the display. On all power

ups, the software model always will transition through the **Stopped** Software state independent of the last mode. If the last mode before power down was **Auto**, the transition from **Stopped** to **Starting** occurs, but it is not apparent to the user.

Figure 65. Sequence of operation: power up diagram

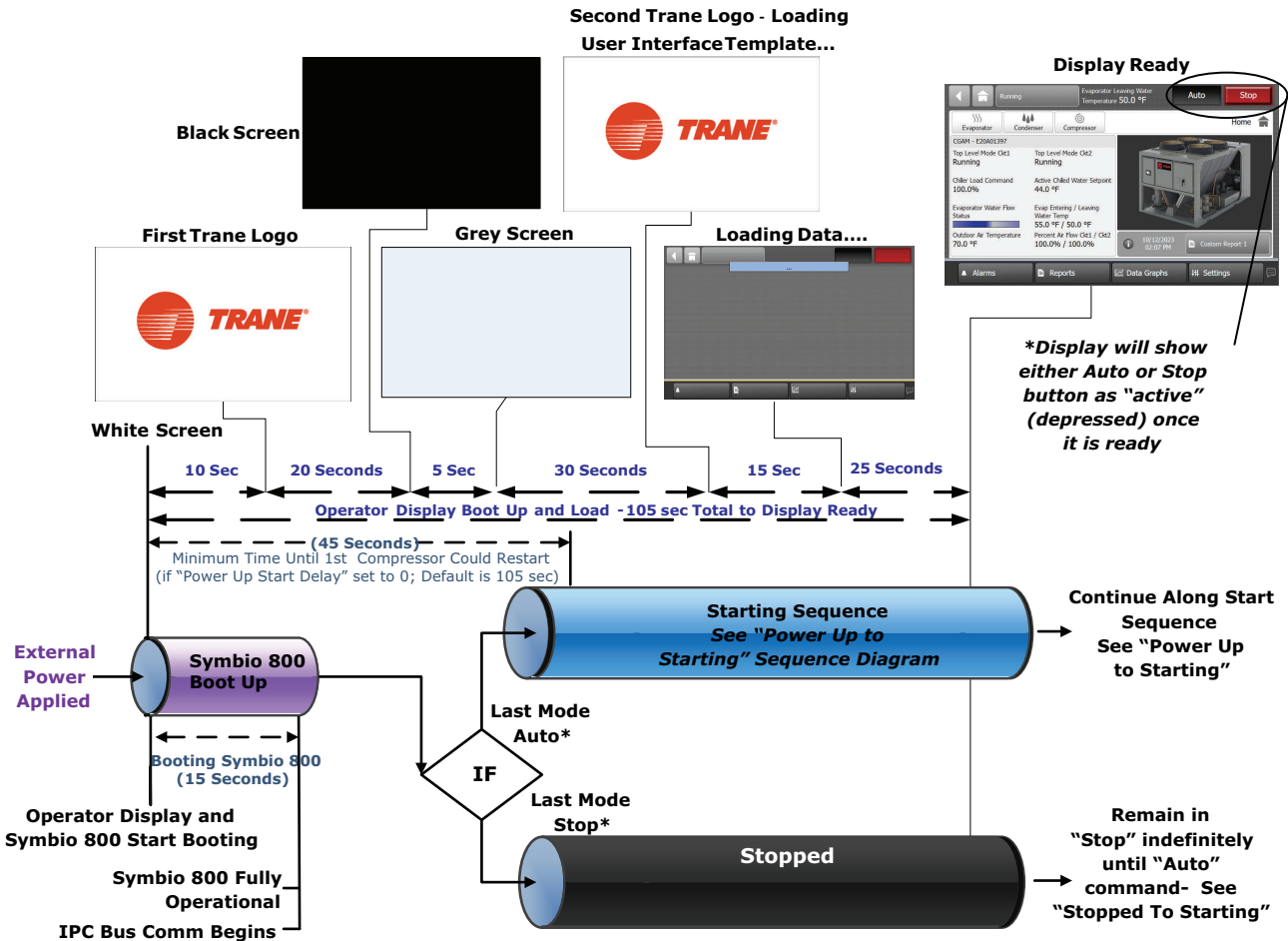

Power Up to Starting

The following diagram shows the timing from a power up event to energizing the first compressor. The shortest allowable time would be under the following conditions:

- No motor restart inhibit time left from subsequent starts
- Evaporator Water flow occurs quickly with pump on command
- Power up Start Delay set to 0 minutes

- Need to cool (differential to start) already exists
- Oil level is detected immediately

The above conditions would allow for a minimum power up to starting the first compressor time of about 45 seconds (variations may exist due to options installed). Note that it is not advisable to start a chiller "cold", the oil heaters should be in operation for a sufficient length of time prior to first start.

Figure 66. Sequence of operation: power up to starting

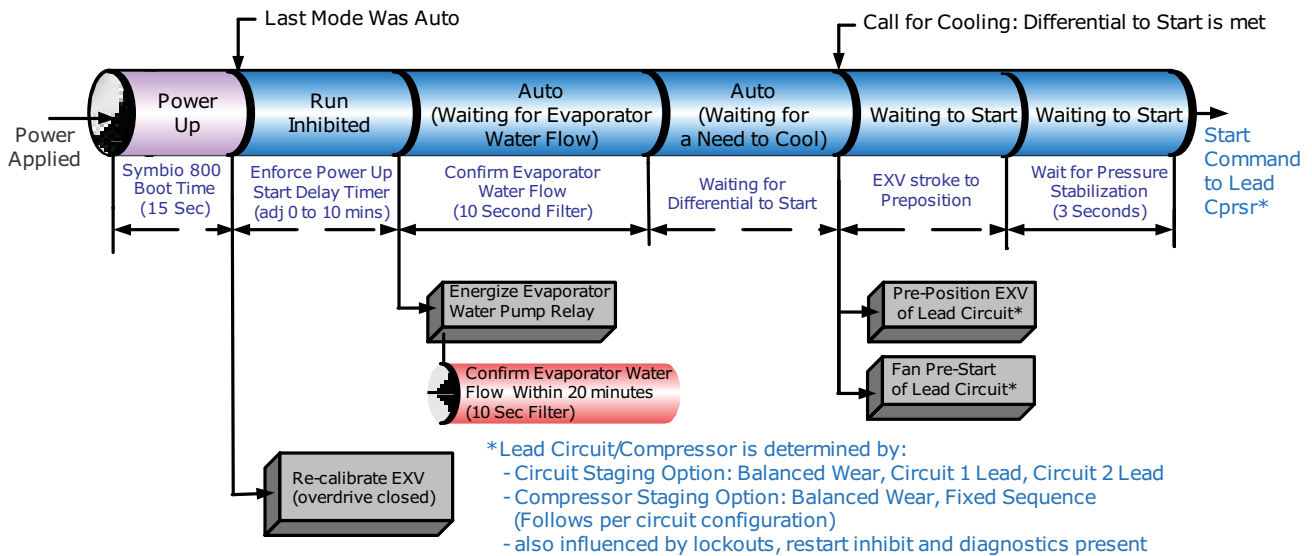

Stopped to Starting

The following diagram shows the timing from a stopped mode to energizing the first compressor. The shortest allowable time would be under the following conditions:

- No motor restart inhibit time left from subsequent starts

- Evaporator water flow occurs quickly with pump on command
- Need to cool (differential to start) already exists
- The above conditions would allow a compressor to start in about 20 seconds.

Figure 67. Sequence of operation: stopped to starting

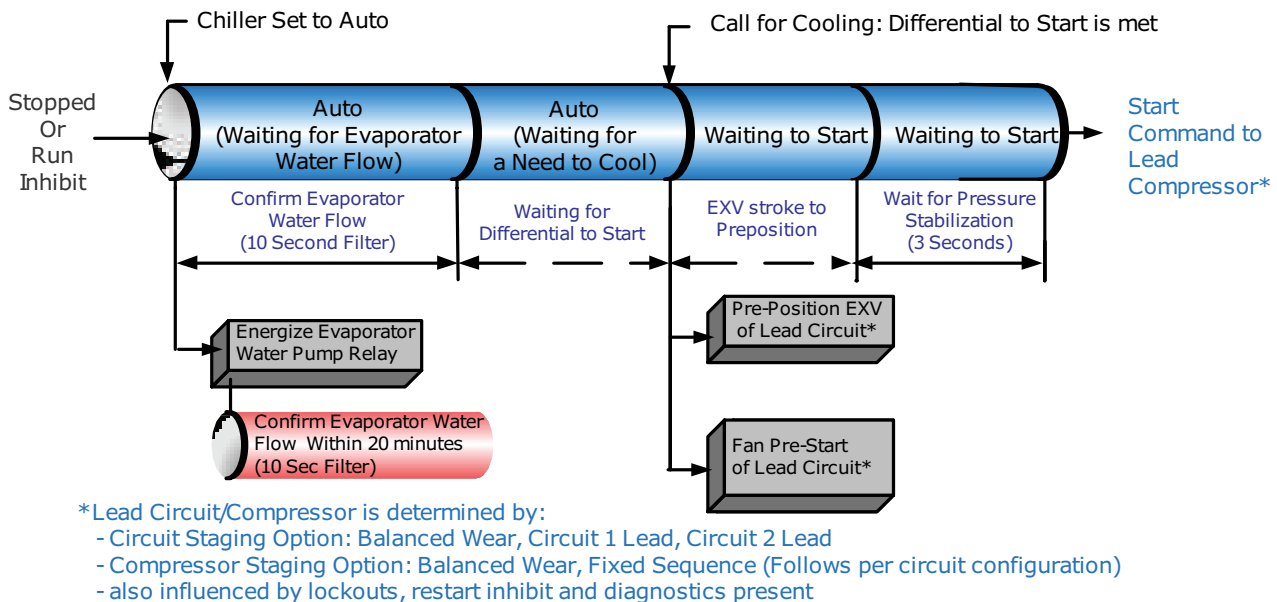

Normal Shutdown to Stopped or Run Inhibit

The following diagram shows the Transition from Running through a Normal (friendly) Shutdown. The dashed lines on

the top attempt to show the final mode if stop is selected via various inputs.

Start-Up and Shutdown

Figure 68. Sequence of operation: normal shutdown to stopped or run inhibit

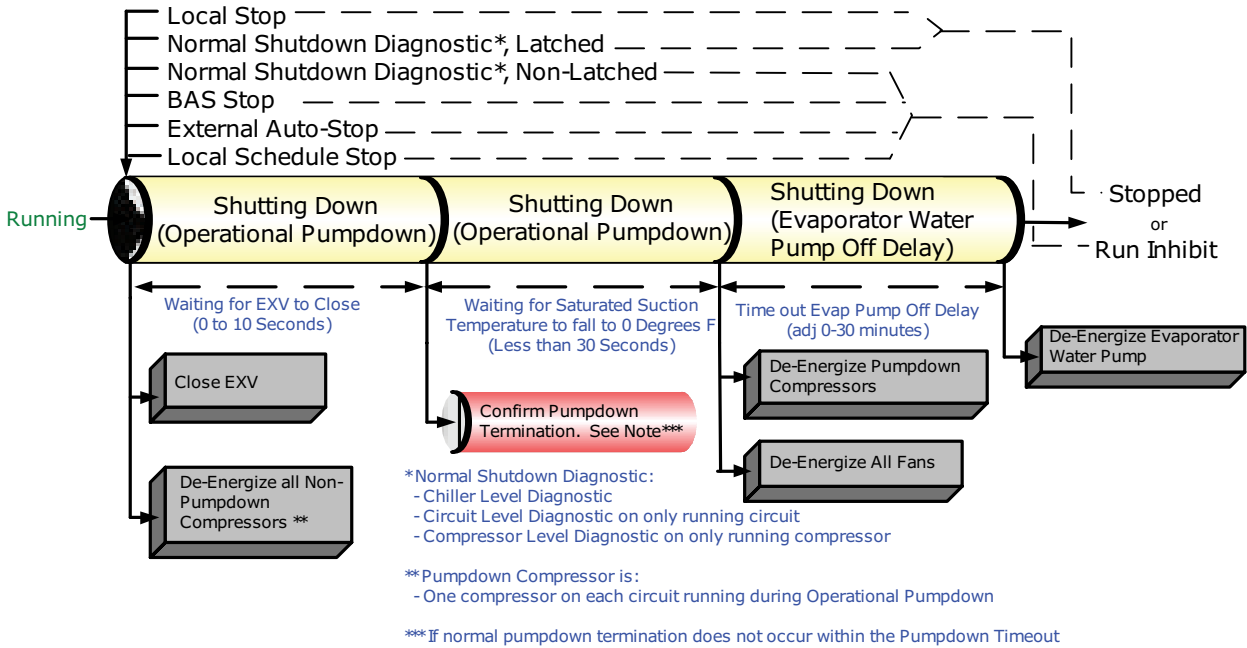



Maintenance

⚠ WARNING

Hazardous Voltage - Pressurized Flammable Fluid!

Failure to follow all electrical safety precautions could result in death or serious injury.

Do not operate compressor without terminal box cover in place.

The motors in the compressors have strong permanent magnet motors and have the capability to generate voltage during situations when the refrigerant charge is being migrated. This potential will be present at the motor terminals and at the output of the variable speed drives in the power panel.

Before removing compressor terminal box cover for servicing, or servicing power side of control panel, **CLOSE COMPRESSOR DISCHARGE SERVICE VALVE** and disconnect all electric power including remote disconnects. Discharge all motor start/run capacitors. Follow lockout/tagout procedures to ensure the power cannot be inadvertently energized. Verify with an appropriate voltmeter that all capacitors have discharged.

The compressor contains hot, pressurized refrigerant. Motor terminals act as a seal against this refrigerant. Care should be taken when servicing **NOT** to damage or loosen motor terminals.

⚠ WARNING

Hazardous Voltage!

Failure to disconnect power before servicing could result in death or serious injury.

Disconnect all electric power, including remote disconnects before servicing. Follow proper lockout/tagout procedures to ensure the power can not be inadvertently energized. Verify that no power is present with a voltmeter.

Perform all maintenance procedures and inspection at the recommended intervals. This will prolong the life of the chiller and minimize the possibility of malfunctions.

Use an **Operators Log** to record the units operating history. The log serves as a valuable diagnostic tool for service personnel. By observing trends in operating conditions, an operator can anticipate and prevent problem situations before they occur.

If the unit is not operating properly during maintenance inspections, see [“Diagnostics,”](#) p. 85.

Recommended Maintenance

Weekly

Verify that compressor oil sump heaters are connected tightly around the compressor.

After the chiller has been operating for approximately 30 minutes and the system has stabilized, check the operating pressures and temperatures and complete the following checks:

Check the evaporator and condenser refrigerant pressures in the Status Report menu of the Tracer TU or TD-7 display. Pressures are referenced at sea level (14.6960 psia).

Check the electronic expansion valve sight glasses.

Note: *The electronic expansion valve is commanded closed at unit shutdown and if the unit is off, there will be no refrigerant flow through the sight glasses. Only when a circuit is running will refrigerant flow be present.*

The refrigerant flow through the sight glasses should be clear. Bubbles in the refrigerant indicate either low refrigerant charge or excessive pressure drop in the liquid line. A restriction in the line can sometimes be identified by a noticeable temperature differential between the two sides of the restriction. Frost may often form on the liquid line at this point. Correct refrigerant charges are shown in the General Data Tables.

Important: *A clear sight glass alone does not mean that the system is properly charged. Also check the system superheat, subcooling and unit operating pressures.*

For more information, see [“Refrigerant and Oil Charge Management,”](#) p. 82.

Monthly

1. Complete all weekly maintenance procedures.
2. Measure and record the evaporator superheat.
3. Measure and record the system subcooling.

Annual

1. Complete all weekly and monthly maintenance checks.
2. Check the oil level and refrigerant charge. Routine changing of oil is not required.
3. Have a qualified laboratory perform a compressor oil analysis to determine system moisture content and acid level. This analysis is a valuable diagnostic tool.
4. Contact a qualified service provider to leak test the chiller, check operating and safety controls, and to inspect electrical components for proper operation. Leak testing may be accomplished using soap solution or with electronic or ultrasonic leak detectors.
5. Inspect all piping components for leaks and damage. Clean all water strainers.

NOTICE

Heater Damage!

Failure to follow instructions below could cause equipment damage.
De-energize evaporator immersion heater and/or any associated evaporator water piping immersion heaters when draining evaporator or evaporator water piping.

6. Clean and repaint any components that show corrosion.
7. Clean the condenser coils per “[Condenser Maintenance](#),” p. 83.

⚠ WARNING

Rotating Components!

Failure to disconnect power before servicing could result in rotating components cutting and slashing technician which could result in death or serious injury.
Disconnect all electric power, including remote disconnects before servicing. Follow proper lockout/tagout procedures to ensure the power can not be inadvertently energized.

8. Clean the condenser fans. Check the fan assemblies for proper clearance in the fan shroud openings and for motor shaft misalignment or abnormal end-play, vibration and noise.
9. Manually rotate the condenser fans to ensure that there is proper clearance on the fan shroud openings. Inspect the entire system for unusual conditions.

Refrigerant and Oil Charge Management

Proper oil and refrigerant charge is essential for proper unit operation, unit performance, and environmental protection. Only trained and licensed service personnel should service the chiller.

[Table 38, p. 82](#) lists baseline measurements for CGAM units running at AHRI standard operating conditions. If chiller measurements vary significantly from values listed below, problems may exist with refrigerant and oil charge levels. Contact your local Trane office.

Note: *Low temperature applications units will have values that vary from [Table 38, p. 82](#). Contact your local Trane office for more information.*

Table 38. Typical CGAM baselines (AHRI conditions)

Measurement	Baseline
Evaporator Pressure	120 psig
Evaporator Approach	5-10°F
EXV Position	40-50% open

Table 38. Typical CGAM baselines (AHRI conditions) (continued)

Measurement	Baseline
Evaporator delta T	10°F
Evaporator Superheat	12°F
Condenser Pressure	420-440 psia
Condensing Approach Temperature	25°F
Subcooling	15-20°F
Compressor Discharge Temperature	63° or more
Compressor Suction Temperature	20° or more
Compressor RLA	100%

Lubrication System

Oil Level

Oil should also be visible in the sight glass when the compressor is running. When operating, each compressor in a tandem or trio set may have a different oil level.

To check compressor oil level, refer to the label near the compressor sight glass. The compressor(s) must be off. Wait three minutes. With tandem or triple compressors the oil level will equalize after shutdown. Compressor oil level should be clearly visible within the sight glass when the compressors are off.

Important: *If oil level is low, contact your local Trane office. Verify that ONLY Trane OIL00080 is used.*

Oil Testing

Use Trane Oil Testing Kit KIT06815 only for testing lubricating oil in the Model CGAM chiller. Note that the POE oil used in this product is very hygroscopic and easily absorbs and retains moisture. The acceptable moisture content is less than 100 ppm and acceptable acid level is less than 0.5 TAN. Note that refrigerant and moisture is very difficult to remove from this oil using vacuum. Also note that once the seal on a container of POE oil is opened, the oil must be used.

In the event of a compressor failure, always test the oil with an acid test kit to determine whether the compressor failure was mechanical or electrical. This is important because it dictates correct cleanup procedure.

Condenser Maintenance

Round Tube Plate Fin Condensers

RTPF Condenser Coil Cleaning

⚠ WARNING

Hazardous Chemicals!

Failure to follow this safety precaution could result in death or serious injury. Coil cleaning agents can be either acidic or highly alkaline and can burn severely if contact with skin or eyes occurs.

Handle chemical carefully and avoid contact with skin. **ALWAYS** wear Personal Protective Equipment (PPE) including goggles or face shield, chemical resistant gloves, boots, apron or suit as required. For personal safety refer to the cleaning agent manufacturer's Materials Safety Data Sheet and follow all recommended safe handling practices.

Clean the condenser coils at least once a year or more frequently if the unit is in a dirty environment. A clean condenser coil will help to maintain chiller operating efficiency.

Follow the detergent manufacturers instructions to avoid damaging the condenser coils.

To clean the condenser coils use a soft brush and a sprayer such as a garden pump type or a high-pressure type. A high quality detergent such as Trane Coil Cleaner (Part No. CHM- 00255) is recommended.

See RTAC-SVG01*-EN for maintenance and cleaning procedures.

Note: If detergent mixture is strongly alkaline (pH value greater than 8.5, an inhibitor must be added).

Evaporator Maintenance

NOTICE

Heater Damage!

Failure to follow instructions below could cause equipment damage.

De-energize evaporator immersion heater and/or any associated evaporator water piping immersion heaters when draining evaporator or evaporator water piping.

The Trane Model CGAM liquid chiller uses a brazed plate heat exchanger (BPHE) evaporator with factory-installed electronic flow switch (IFM efector) that is positioned in the evaporator water pipe. The evaporator inlet also includes a factory-installed immersion heater for freeze protection and a water strainer that must be kept in place to keep debris out of the evaporator.

Note: Strainer maintenance is critical to proper operation and reliability. Any particles larger than 1mm entering the BPHE evaporator may cause the evaporator to fail, requiring replacement.

Acceptable BPHE evaporator water flow rate is 1.5 to 3.6 GPM per nominal unit ton capacity. To maintain 54-44°F in/out chilled water temperatures, the nominal water flow rate is 2.4 GPM/ton.

Minimum water flow rate must be maintained to avoid laminar flow, potential evaporator freezing, scaling and poor temperature control. The microprocessor and capacity control algorithms are designed to take a 10 percent change in water flow rate per minute while maintaining a $\pm 2^\circ\text{F}$ (1.1°C) leaving water temperature control accuracy. The chiller tolerates up to 30 percent per minute water flow variation as long as the flow is equal to or greater than minimum flow requirements.

Maximum water flow is 18 feet per second. Flow rates greater than this will cause excessive erosion.

The BPHE evaporator is difficult to clean should it become plugged with debris. Indications of a plugged BPHE evaporator include wet suction due to lack of heat exchange, loss of superheat control, depressed discharge superheat, compressor oil dilution and/or starvation and premature compressor failure.

Water Strainer Maintenance

For units with optional pump package, the factory-installed water strainer is a Y-type design with a cylindrical sieve.

Figure 69. Y type strainer — units with optional pump package

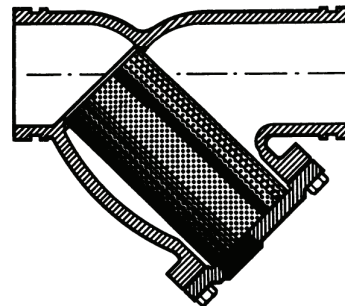

An in-line strainer with a V-shaped sieve is used for units that do not have factory-installed pump package option.

Figure 70. In-line strainer — units without optional pump package

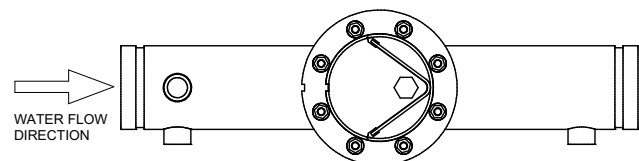

The strainer is equipped with a blow-down port. The strainer is a 16 mesh (approximately 1 mm) material.

For maximum efficiency, a differential pressure gauge installed across the inlet and outlet will indicate pressure loss due to clogging and may be used as a guide to



Maintenance

determine when cleaning is required. The taps for the pressure gauges are included as standard from the factory.

Normally when differential pressure reaches 5-10psi, the screen must be cleaned. The strainer is equipped with a blowdown port on the cover plate. To clean open and flush out until any sediment is removed.

Pump Package Maintenance

Rust Prevention

Pumps not immediately placed into service, or removed from service and stored, must be properly prepared to prevent excessive rusting.

- Pump port protection plates must not be removed until the pump is ready to connect to the piping.
- Rotate the shaft periodically (at least monthly) to keep rotating element free and bearings fully functional.

- For long term storage (3 months or longer), prevent internal rust buildup and possibility of freezing by performing the following steps:
 - Remove the plugs at the top and bottom of the casing.
 - If water is to be drained:
 - Disconnect evaporator and piping heaters.
 - Drain or blow out all water.
 - As an optional step, it is acceptable to rustproof or pack the casing with moisture absorbing material and cover the flanges.

When returning pumps to service

- Remove drying agent from the pump, if used.
- Reinstall plugs at the top and bottom of the casing.
- If water had been drained:
 - Refill water.
 - Reconnect evaporator and piping heaters.



Diagnostics

General Diagnostics Information

Diagnostic Name and Source: Diagnostics may be shown in the spec with a source of "xy". In this case, letter "x" can be either "1" or "2" (signifying which circuit) and letter "y" can be "A", "B" or "C" (signifying which compressor on that circuit). Some circuit diagnostics don't have 'x' letter to indicate which circuit is failing. Refer to TD-7 alarm display for this information.

Affects Target: Defines the "target" or what is affected by the diagnostic. Usually either the entire Chiller, or a particular Circuit or Compressor is affected by the diagnostic (the same one as the source), but in special cases functions are modified or disabled by the diagnostic. "None" implies that there is no direct affect to the chiller, sub components or functional operation.

Design Note: Functions that are affected by a diagnostic are simply reported as "chiller or circuit x" targets in Tracer® TU and on the Alarms page of the AdaptiView™ display, even though only a specific function and not the entire circuit or chiller would be effected.

Severity: Defines the severity of the above effect. Immediate means immediate shutdown of the affected portion, Normal means normal or friendly shutdown of the affected portion, Special Action means a special action or mode of operation (limp along) is invoked, but without shutdown, and Info means an Informational Note or Warning is generated. Design Note: Tracer TU does not support display of "Special Action", on its Diagnostics pages, so that if a diagnostic has a special action defined in

the table below, it will be displayed only as "Informational Warning" as long as no circuit or chiller shutdown results. If there is a shutdown and special action defined in the table, then the Tracer TU Diagnostics Page display will indicate the shutdown type only.

Persistence: Defines whether or not the diagnostic and its effects are to be manually reset (Latched), or can be either manually or automatically reset when and if the condition returns to normal (Nonlatched).

Active Modes [Inactive Modes]: States the modes or periods of operation that the diagnostic is active in and, as necessary, those modes or periods that it is specifically "not active" in as an exception to the active modes. The inactive modes are enclosed in brackets, []. Note that the modes used in this column are internal and not generally announced to any of the formal mode displays.

Criteria: Quantitatively defines the criteria used in generating the diagnostic and, if nonlatching, the criteria for auto reset.

Reset Level: Defines the lowest level of manual diagnostic reset command which can clear the diagnostic. The manual diagnostic reset levels in order of priority are: Local or Remote. For example, a diagnostic that has a reset level of Remote, can be reset by either a remote diagnostic reset command or by a local diagnostic reset command.

Main Processor Diagnostics

Table 39. Main processor diagnostics

Diagnostic Name	Affects	Severity	Persistence	Active Modes [Inactive Modes]	Criteria	Reset Level
Compressor X Fault	Cprsr	Immediate	NonLatch	All	The compressor fault switch input is open.	Local
Compressor Fault Lockout	Cprsr	Immediate	Latch	All	The compressor fault switch input remained open for more than 35 minutes. Five compressor fault diagnostics have occurred within the last 210 minutes.	Local
Condenser Fan Fault - CktX	Circuit	Warning	Latch	All	The fan deck is indicating a fault on the associated circuit.	Remote
Emergency Stop Feedback Input	Chiller	Immediate	Latch	All	Emergency Stop input is open.	Local
Energy Meter Write Value Failure	Chiller	Warning	Latch	All	Loss of communication to the Energy Meter during write command process (Controller writes to Energy Meter). Only applies to Veris Energy Meter.	Remote
Evaporator Pump 1 Starts/Hours Modified	Chiller	Warning	NonLatch	All	A counter for evaporator pump 1 starts or hours has been modified by the service tool. This diagnostic is immediately and automatically cleared and thus can only be seen in the historic diagnostic list.	NA
Evaporator Pump 2 Starts/Hours Modified	Chiller	Warning	NonLatch	All	A counter for evaporator pump 2 starts or hours has been modified by the service tool. This diagnostic is immediately and automatically cleared and thus can only be seen in the historic diagnostic list.	NA

Table 39. Main processor diagnostics (continued)

Diagnostic Name	Affects	Severity	Persistence	Active Modes [Inactive Modes]	Criteria	Reset Level
Evaporator Water Flow Lost	Chiller	Immediate and Special Action	NonLatch	All	After the pump request was activated, water flow was established and then lost. Special action is to keep the evap pump request active in a diagnostic override mode.	Remote
Evaporator Water Flow Lost – Pump 1	Chiller	Warning and Special Action	NonLatch	All	For dual evaporator pump configurations only. Evaporator Water Flow Lost diagnostic occurred while Pump 1 was the selected pump.	Remote
Evaporator Water Flow Lost – Pump 2	Chiller	Warning and Special Action	NonLatch	All	For dual evaporator pump configurations only. Evaporator Water Flow Lost diagnostic occurred while Pump 2 was the selected pump.	Remote
Evaporator Water Flow Lost Lockout	Chiller	Immediate	Latch	All	After the pump request was activated, water flow was established and then lost. Special action is to keep the evap pump request active in a diagnostic override mode.	Remote
Evaporator Water Flow Lost Lockout	Chiller	Immediate	Latch	All	Four (4) water flow loss events occurred in a moving 4 day time window. Corrective action is needed to identify and eliminate the cause.	Local
Evaporator Water Flow Overdue	Chiller	Immediate and Special Action	NonLatch	All	After the pump request was activated, the evaporator water flow overdue wait time elapsed before water flow was established. Special action is to keep the evap pump request active in a diagnostic override mode.	Remote
Evaporator Water Flow Overdue – Pump 1	Chiller	Warning and Special Action	NonLatch	All	For dual evaporator pump configurations only. Evaporator Water Flow Overdue diagnostic occurred while Pump 1 was the selected pump.	Remote
Evaporator Water Flow Overdue – Pump 2	Chiller	Warning and Special Action	NonLatch	All	For dual evaporator pump configurations only. Evaporator Water Flow Overdue diagnostic occurred while Pump 2 was the selected pump.	Remote
Evaporator Water Flow Too Low	Chiller	Immediate	Latch	Cooling Mode [Not Cooling Mode]	Refrigerant side to water side heat balance indicates that water flow has dropped below allowable manufacturer limits.	Local
External Chilled/Hot Water Setpoint	Chiller	Warning	NonLatch	All	a. Function Not “Enabled”: no diagnostics. b. “Enabled “: Out-Of-Range Low or Hi or bad LLID, set diagnostic, default CWS/HWS to next level of priority (e.g. Front Panel Setpoint). This Warning diagnostic will automatically reset if the input returns to the normal range.	Remote
External Demand Limit Setpoint	Chiller	Warning	NonLatch	All	a. Function Not “Enabled”: no diagnostics. b. “Enabled “: Out-Of-Range Low or Hi or bad LLID, set diagnostic, default DLS to next level of priority (e.g. Front Panel Setpoint). This Warning diagnostic will automatically reset if the input returns to the normal range.	Remote
Evaporator Pump 1 Fault	Chiller	Immediate or Warning and Special Action	NonLatch	All	For systems with no evaporator pump, a single evaporator pump, or a single inverter driving dual evaporator pumps, an immediate shutdown shall be performed. For multiple pump systems, detection of a pump fault will generally cause pump control to switch to the redundant pump. For single inverter, dual pump configuration, switching to the redundant pump can only happen after the fault is cleared.	Remote
Evaporator Pump 2 Fault	Chiller	Immediate or Warning and Special Action	NonLatch	All	For systems with no evaporator pump, a single evaporator pump, or a single inverter driving dual evaporator pumps, an immediate shutdown shall be performed. For multiple pump systems, detection of a pump fault will generally cause pump control to switch to the redundant pump. For single inverter, dual pump configuration, switching to the redundant pump can only happen after the fault is cleared.	Remote
Fan Inverter Fault	Circuit	Warning	NonLatch	Ckt Energized [Ckt Not Energized] All	The fan inverter fault input is ignored for the first 5 seconds of start-up to allow variable speed drives to power up.	Remote

Table 39. Main processor diagnostics (continued)

Diagnostic Name	Affects	Severity	Persistence	Active Modes [Inactive Modes]	Criteria	Reset Level
High Compressor Pressure Differential	Circuit	Immediate	Latch	Ckt Energized [Ckt Not Energized or Operational Pumpdown]	Compressor involute pressure differential exceeded allowable limits.	Local
High Discharge Refrigerant Pressure	Circuit	Immediate	Latch	All	Discharge pressure exceeded the high pressure cutout setpoint + 100 kPa. Likely cause: failed or incorrectly set high pressure cutout switch. Prevents release of refrigerant through relief valve.	Local
High Discharge Temperature	Circuit	Immediate	NonLatch	Ckt Energized [Ckt Not Energized]	The discharge temperature exceeded the limits for the compressor.	Local
High Discharge Temperature Lockout	Circuit	Immediate	Latch	All	5 high discharge temperature diagnostics occurred over 210 minutes.	Local
High Evaporator Water Temperature	Chiller	Info and Special Action	NonLatch	Only effective if either 1) Evaporator Water Flow Overdue, 2) Evaporator Water Flow Lost, 3) Low Evap Water Temp: Unit Off, diagnostic is active.	The leaving water temperature exceeded the high evap water temp setting (TV service menu settable– default 55.0°C (131°F)) for 15 continuous seconds. The evaporator water pump relay will be de-energized to stop the pump, but only if it is running due to one of the diagnostics listed on the left. The diagnostic will auto reset and the pump will return to normal control when the temperature falls 2.778°C (5°F) below the trip setting. The primary purpose is to stop the evaporator water pump and its associated pump heat from causing excessive water-side temperatures and water-side pressures when the unit is not running but the evap pump is on due to either Evaporator Water Flow Overdue, Evaporator Water Flow Lost, or Low Evap Water Temp – Unit Off diagnostics. This diagnostic will not auto clear solely due to the clearing of the enabling diagnostic. *at unit installation, especially reversible units, high evap water temp setting will need to be written. The value should be approximately 65.556°C (150°F) for heat pumps.	Remote
High Pressure Cutout	Circuit	Immediate	Latch	All	The high pressure cutout switch recognized a high pressure.	Local
High Suction Refrigerant Pressure	Chiller	Immediate	NonLatch	All	Any circuit's suction pressure has risen above 95% of the high pressure cutout setting. The evaporator water pump relay will be de-energized to stop the pump regardless of why the pump is running. The diagnostic will auto reset and the pump will return to normal control when all circuits' suction pressures fall below 85% of the high pressure cutout setting. The primary purpose is to stop the evaporator water pump and its associated pump heat from causing refrigerant side pressures close to the relief valve setting when the chiller is not running, such as could occur with Evaporator Water Flow Overdue, Evaporator Water Flow Lost, or Low Evap Water Temp – Unit Off diagnostics. This condition is unlikely unless a discharge isolation valve is installed and closed.	Remote
Inverted Evaporator Water Temperature	Chiller	Warning or Normal	NonLatch or Latch	Any Ckt(s) Energized [No Ckt(s) Energized]	The entering evaporator water temp fell below the leaving evaporator water temperature by more than 3°F for 100°F-sec while at least one compressor was running. Severity and Persistence depends on the Inverted Water Temp Diagnostic Severity setpoint (Default = Warning/ NonLatching).	Remote

Diagnostics
Table 39. Main processor diagnostics (continued)

Diagnostic Name	Affects	Severity	Persistence	Active Modes [Inactive Modes]	Criteria	Reset Level
Inverted Water Temp (Heating)	Chiller	Warning or Normal	NonLatch or Latch	Unit energized and all ckt's reversing valves in heating direction [Unit deenergized or any ckt's reversing valve in cooling direction]	The leaving evaporator water temp fell below the entering evaporator water temperature by more than 3°F for 100°F-sec. Severity and Persistence depends on the Inverted Water Temp Diagnostic Severity setpoint (Default = Warning/NonLatching). There is a 60 second ignore time after the condition to enable the diagnostic is met. During the ignore time, the temperature error is not integrated.	Remote
Loss of Charge	Circuit	Immediate	Latch	Ckt Energized [Ckt Not Energized]	This feature is active on cooling-only units, and heat pumps when in cooling mode. The circuit must have EXV superheat control.	Local
Low Differential Refrigerant Pressure	Circuit	Normal	Latch	Ckt Energized [Ckt Not Energized]	The system differential pressure for the respective circuit was below 90 psid for more than 4000 psidsec, with a 2.5 minute ignore time from the start of the circuit.	Local
Low Discharge Saturated Temperature	Circuit	Normal	Latch	Ckt Energized [Ckt Not Energized]	The discharge saturated temperature for the respective circuit was below 20 °C for more than 3750 °C-sec, with a 10 minute ignore time from the start of the circuit. Integration starts after the ignore time is completed.	Local
Low Evaporator Water Temp (Unit Off)	Chiller or Circuit	Warning and Special Action	NonLatch	Unit in Stop Mode, or in Auto Mode and No Ckt(s) Energized [Any Ckt Energized]	The leaving chilled water temperature fell below the leaving water temp cutout setting for 30 degree F seconds while the Chiller is in the Stop mode, or in Auto mode with no compressors running. Energize Evap Water pump Relay until diagnostic auto resets, then return to normal evap pump control. Automatic reset occurs when the temp rises 2°F above the cutout setting for 30 minutes. When this diagnostic is active AND Leaving Water Temperature sensor diagnostic (loss of comm or out of range) the Evap Water pump relay shall be de-energized. If evaporator protection temperature sensors are installed, the effect is on the appropriate circuit. Else, the effect is on the chiller.	Remote
Low Evaporator Water Temp (Unit On)	Chiller or Circuit	Immediate and Special Action	NonLatch	Any Ckt(s) Energized [No Ckt(s) Energized]	The evap entering or leaving water temperature fell below the cutout setpoint for 30 degree F Seconds while a compressor was running. Automatic reset occurs when the temperature rises 2 °F above the cutout setting for 2 minutes. This diagnostic shall not deenergize the Evaporator Water Pump Output. If this diagnostic is active the Low Evap Leaving Water Temp: Unit Off diagnostic shall be suppressed. If evaporator protection temperature sensors are installed, the effect is on the appropriate circuit. Else, the effect is on the chiller.	Remote
Low Suction Refrigerant Pressure	Circuit	Immediate	Latch	All	The suction refrigerant pressure fell below the low pressure cutout trip point.	Local
Low Refrigerant Temperature	Circuit	Immediate	Latch	Circuit Energized [Service Pumpdown, Operational Pumpdown]	The suction saturated refrigerant temperature dropped below the Low Refrigerant Temperature Cutout Setpoint for 16.67°C-seconds (30°Fseconds).	Local
Low Suction Superheat	Circuit	Immediate	Latch	Ckt Energized [Ckt Not Energized]	Measured suction superheat stays below 2.22 °C for one continuous minute, with a 1 minute ignore time from the start of the circuit. Suction Superheat = suction temp – sat. suction temp.	Local

Table 39. Main processor diagnostics (continued)

Diagnostic Name	Affects	Severity	Persistence	Active Modes [Inactive Modes]	Criteria	Reset Level
MP: Reset Has Occurred	Chiller	Warning	NonLatch	All	The main processor has successfully come out of a reset and built its application. A reset may have been due to a power up, installing new software or configuration. This diagnostic is immediately and automatically cleared and thus can only be seen in the historic diagnostic list.	NA
No Partial Heat Recovery	Circuit	Warning	NonLatch	Ckt Energized [Ckt Not Energized]]	PHR entering water temperature is greater than the discharge temperature by 1.11 °C for 30 continuous minutes.	Remote
No Total Heat Recovery	Heat Recovery	Warning	NonLatch	Unit energized and THR control enabled [Unit deenergized or THR disabled]	This diagnostic is only effective if all the following requirements are met: 1) Unit is running. 2) THR Control is enabled. 3) THR entering water temperature is less than 4° C, or discharge temperature integral is greater than Discharge Temperature Integral Limit in all the energized circuits. It shall be de-activated when any one of the following requirement is met: 1) THR entering water temperature is greater than 5°C., and the discharge saturated temperature is greater than minimum discharge saturated temperature in at least one energized circuit, see Total Heat Recovery Control Algorithm specification for details. 2) THR entering water temperature is invalid (comm loss or sensor diagnostic). 3) Total Heat Recovery Control disabled. 4) No compressor energized.	Remote
Phase Protection Fault	Chiller	Immediate	NonLatch	All	Phase protection module recognized a phase loss or phase reversal of the line power. Reset automatically after module recognizes good power for 30 continuous seconds.	Local
Power Factor Correction Fault	Chiller	Warning	Latch	All	Power Factor Correction module has signaled a fault condition.	Remote
Pumpdown Terminated By Time	Circuit	Warning	Latching	Operational/ Service Pumpdown [All Except Operational and Service Pumpdown]	Operational Pumpdown or Service Pumpdown procedure did not terminate normally by reaching the termination pressure within the allotted time.	Remote
Software Error 1001: Call Trane Service	All functions	Immediate	Latch	All	A software monitor has detected a condition in which there was a continuous 1 minute period of compressor operation, with no Evaporator water flow. The presence of this software error message suggests an internal software problem has been detected. The events that led up to this failure, if known, should be recorded and transmitted to Trane Controls Engineering.	Local
Software Error 1002: Call Trane Service	All functions	Immediate	Latch	All	A software monitor has detected a condition in which there was a continuous 1 minute period of compressor operation, with a misaligned statemachine. Reported if state chart misalignment occurred inferred from the Capacity Control, Circuit, or Compressor State Machines being in Stopped state or Inactive state while a compressor was operating and this condition existed for at least 1 minute. The presence of this software error message suggests an internal software problem has been detected. The events that led up to this failure, if known, should be recorded and transmitted to Trane Controls Engineering.	Local



Diagnostics

Table 39. Main processor diagnostics (continued)

Diagnostic Name	Affects	Severity	Persistence	Active Modes [Inactive Modes]	Criteria	Reset Level
Software Error 1003: Call Trane Service	All functions	Immediate	Latch	All	A software monitor has detected a condition in which there was a continuous 1 minute period of compressor operation, with a misaligned state machine. Reported if state chart misalignment occurred inferred from the Capacity Control, Circuit, or Compressor State Machines remaining in the Stopping state for more than 4 minutes with operating compressors. The presence of this software error message suggests an internal software problem has been detected. The events that led up to this failure, if known, should be recorded and transmitted to Trane Controls Engineering.	Local
Starts/Hr Modified - CprsrXY	Cprsr	Warning	NonLatch	All	A counter for compressor starts or hours has been modified by TechView. This diagnostic is immediately and automatically cleared and thus can only be seen in the historic diagnostic list.	NA
Suction Temperature Too High	Circuit	Immediate	Latch	Ckt Energized [Ckt Not Energized]	The suction temperature measurement is larger than the entering temperature by more than a threshold value for 5 continuous minutes. The threshold value is 3°C (5.4°F) for cooling-only units, and 5°C (9°F) for heat pumps. The entering temperature is the evaporator entering water temperature when the reversing valve is in the cooling direction, and the ambient air temperature when the reversing valve is in the heating direction. There is an ignore time of 2 minutes following circuit startup. The trip criteria is not evaluated (and time above the threshold is not counted) until the ignore time passes.	Local
Very Low Suction Pressure – Circuit 1	Chiller	Immediate	Latch	All [circuit in manual lockout]	The circuit's suction pressure dropped below (Low Pressure Cutout Setpoint (kPa absolute) * 0.5) regardless of whether or not compressors are running on that circuit. This diagnostic was created to prevent compressor failures due to crossbinding by forcing an entire chiller shutdown.	Local
Very Low Suction Pressure – Circuit 2	Chiller	Immediate	Latch	All [circuit in manual lockout]	The circuit's suction pressure dropped below (Low Pressure Cutout Setpoint (kPa absolute) * 0.5) regardless of whether or not compressors are running on that circuit. This diagnostic was created to prevent compressor failures due to crossbinding by forcing an entire chiller shutdown.	Local

Sensor Failure Diagnostic

Notes:

1. *The following sensor failure diagnostics will not occur unless that input or output is required to be present by the particular configuration and installed options for the unit.*
2. *Sensor diagnostics are named by the Functional Name of the input or output that is no longer sending a valid value to the Main Processor, indicating a sensor failure. Some LLIDs may have more than one functional output associated with it. Refer to the unit's wiring diagrams to relate the occurrence of such sensor failure diagnostics back to the physical LLID boards that they have been assigned to (bound).*

Table 40. Sensor failure diagnostics

Diagnostic Name	Affects	Severity	Persistence	Active Modes [Inactive Modes]	Criteria	Reset Level
Discharge Pressure Transducer	Circuit	Immediate	Latch	All	Bad Sensor or LLID	Remote
Discharge Temperature Sensor	Circuit	Immediate	Latch	All	Bad Sensor or LLID	Remote
Evaporator Entering Water Temp Sensor	Chiller	Normal	Latch	All	Bad Sensor or LLID	Remote
Evaporator Leaving Water Temp Sensor	Chiller	Normal	Latch	All	Bad Sensor or LLID	Remote
Heat Recovery Entering Water Temp Sensor	Heat Recovery	Warning or Normal	Latch	All	Bad Sensor or LLID. Warning for Partial Heat Recovery. Normal shutdown for Total Heat Recovery.	Remote
Heat Recovery Leaving Water Temp Sensor	Heat Recovery	Warning	Latch	All	Bad Sensor or LLID	Remote
Outdoor Air Temp Sensor	Chiller	Normal	Latch	All	Bad Sensor or LLID	Remote
Suction Pressure Transducer	Circuit	Immediate	Latch	All	Bad Sensor or LLID	Remote
Suction Temperature Sensor	Circuit	Immediate	Latch	All	Bad Sensor or LLID	Remote

Communication Diagnostics

Note: The following communication loss diagnostics will not occur unless that input or output is required to be present by the particular configuration and installed options for the chiller. Communication diagnostics are named by the Functional Name of the input or output that is no longer being heard from by the Main Processor. Many LLIDs, such as the Quad Relay LLID, have more than one functional output associated with it. A comm loss with such a multiple function board, will generate multiple diagnostics. Refer to the Chiller's wiring diagrams to relate the occurrence of multiple communication diagnostics back to the physical LLID boards that they have been assigned to (bound).

Table 41. Communication diagnostics

Diagnostic Name	Affects	Severity	Persistence	Active Modes [Inactive Modes]	Criteria	Reset Level
Comm Loss: Auxiliary Setpoint Command	Chiller	Warning and Special Action	Latch	All	Continual loss of communication between the MP and the Functional ID has occurred for a 35-40 second period. Chiller shall discontinue use of the Auxiliary Setpoint and revert to the Chilled Water Setpoint based on setpoint arbitration.	Remote
Comm Loss: Compressor Fault Input	Cprsr	Immediate	Latch	All	Continual loss of communication between the MP and the Functional ID has occurred for a 35-40 second period.	Remote
Comm Loss: Condenser Fan Enable	Circuit	Immediate	Latch	All	Continual loss of communication between the MP and the Functional ID has occurred for a 35-40 second period.	Remote

Table 41. Communication diagnostics (continued)

Diagnostic Name	Affects	Severity	Persistence	Active Modes [Inactive Modes]	Criteria	Reset Level
Comm Loss: Condenser Fan Fault - CktX	Circuit	Warning	Latch	All	Continual loss of communication between the MP and the Functional ID has occurred for a 35-40 second period.	Remote
Comm Loss: Cooling EXV	Circuit	Immediate	Latch	All	Continual loss of communication between the MP and the Functional ID has occurred for a 35-40 second period.	Remote
Comm Loss: Discharge Pressure Transducer	Circuit	Immediate	Latch	All	Continual loss of communication between the MP and the Functional ID has occurred for a 35-40 second period.	Remote
Comm Loss: Discharge Temperature Sensor	Circuit	Immediate	Latch	All	Continual loss of communication between the MP and the Functional ID has occurred for a 35-40 second period.	Remote
Comm Loss: Electronic Expansion Valve	Circuit	Immediate	Latch	All	Continual loss of communication between the MP and the Functional ID has occurred for a 35-40 second period.	Remote
Comm Loss: Emergency Stop Feedback Input	Chiller	Normal	Latch	All	Continual loss of communication between the MP and the Functional ID has occurred for a 35-40 second period.	Remote
Comm Loss: Energy Meter	Chiller	Warning	Latch	All	Continual loss of communication between the MP and the Functional ID has occurred for a 35-40 second period.	Remote
Comm Loss: Evaporator Antifreeze Heater	Chiller	Warning and Special Action	Latch	All	Continual loss of communication between the MP and the Functional ID has occurred for a 35-40 second period.	Remote
Comm Loss: Evap Entering Water Temp	Chiller	Normal	Latch	All	Continual loss of communication between the MP and the Functional ID has occurred for a 35-40 second period.	Remote
Comm Loss: Evap Leaving Water Temp	Chiller	Normal	Latch	All	Continual loss of communication between the MP and the Functional ID has occurred for a 35-40 second period.	Remote
Comm Loss: Evap Pump Inverter 1 Fault Input	Chiller	Normal	Latch	All	Continual loss of communication between the MP and the Functional ID has occurred for a 35-40 second period.	Remote
Comm Loss: Evap Pump Inverter 1 Frequency Feedback	Chiller	Normal	Latch	All	Continual loss of communication between the MP and the Functional ID has occurred for a 35-40 second period.	Remote
Comm Loss: Evap Pump Inverter 1 Run Command	Chiller	Normal	Latch	All	Continual loss of communication between the MP and the Functional ID has occurred for a 35-40 second period.	Remote
Comm Loss: Evaporator Pump 1 Fault Input	Chiller	Normal	Latch	All	Continual loss of communication between the MP and the Functional ID has occurred for a 35-40 second period.	Remote
Comm Loss: Evaporator Pump 2 Fault Input	Chiller	Normal	Latch	All	Continual loss of communication between the MP and the Functional ID has occurred for a 35-40 second period.	Remote
Comm Loss: Evaporator Water Flow Switch	Chiller	Immediate	Latch	All	Continual loss of communication between the MP and the Functional ID has occurred for a 35-40 second period.	Remote
Comm Loss: Evaporator Water Pump 1 Relay	Chiller	Normal	Latch	All	Continual loss of communication between the MP and the Functional ID has occurred for a 35-40 second period.	Remote
Comm Loss: Evaporator Water Pump 2 Relay	Chiller	Normal	Latch	All	Continual loss of communication between the MP and the Functional ID has occurred for a 35-40 second period.	Remote
Comm Loss: External Auto/Stop	Chiller	Normal	Latch	All	Continual loss of communication between the MP and the Functional ID has occurred for a 35-40 second period.	Remote
Comm Loss: Ext Chilled/Hot Water Setpoint	Chiller	Warning and Special Action	Latch	All	Continual loss of communication between the MP and the Functional ID has occurred for a 35-40 second period. Chiller shall discontinue use of the External Chilled/Hot Water Setpoint source and revert to the next higher priority for setpoint arbitration.	Remote

Table 41. Communication diagnostics (continued)

Diagnostic Name	Affects	Severity	Persistence	Active Modes [Inactive Modes]	Criteria	Reset Level
Comm Loss: External Circuit Lockout	Circuit	Warning and Special Action	Latch	All	Continual loss of communication between the MP and the Functional ID has occurred for a 35-40 second period. MP will nonvolatily hold the lockout state that was in effect at the time of comm loss.	Remote
Comm Loss: Ext Demand Limit Setpoint	Chiller	Warning and Special Action	Latch	All	Continual loss of communication between the MP and the Functional ID has occurred for a 35-40 second period. Chiller shall discontinue use of the External Demand Limit Setpoint source and revert to the next higher priority for setpoint arbitration.	Remote
Comm Loss: External Heat Recovery Command	Heat Recovery	Warning and Special Action	Latch	All	Continual loss of communication between the MP and the Functional ID has occurred for a 35-40 second period. External input is excluded from arbitration logic per standard arbitration rules.	Remote
Comm Loss: External Hot Water Command	Chiller	Normal	Latch	All	Continual loss of communication between the MP and the Functional ID has occurred for a 35-40 second period.	Remote
Comm Loss: External Ice Building Command	Chiller	Warning	Latch	All	Continual loss of communication between the MP and the Functional ID has occurred for a 35-40 second period. Chiller shall revert to normal (non-ice building) mode regardless of last state.	Remote
Comm Loss: External Noise Reduction Request	Chiller	Warning and Special Action	Latch	All	Continual loss of communication between the MP and the Functional ID has occurred for a 35-40 second period. External input is excluded from arbitration logic per standard arbitration rules.	Remote
Comm Loss: Fan Inverter Fault	Circuit	Warning and Special Action	Latch	All	Continual loss of communication between the MP and the Functional ID has occurred for a 35-40 second period. Revert to fixed-speed fan algorithm using remaining fans.	Remote
Comm Loss: Fan Inverter Speed Command	Circuit	Warning and Special Action	NonLatch	All	Continual loss of communication between the MP and the Functional ID has occurred for a 35-40 second period. Revert to fixed-speed fan algorithm using remaining fans.	Remote
Comm Loss: Heat Recovery Entering Water Temperature Sensor	Heat Recovery	Warning or Normal	Latch	All	Continual loss of communication between the MP and the Functional ID has occurred for a 35-40 second period. Warning for Partial Heat Recovery. Normal shutdown for Total Heat Recovery.	Remote
Comm Loss: Heat Recovery Leaving Water Temperature Sensor	Heat Recovery	Warning	Latch	All	Continual loss of communication between the MP and the Functional ID has occurred for a 35-40 second period.	Remote
Comm Loss: Heat Recovery Three Way Valve	Heat Recovery	Normal	Latch	All	Continual loss of communication between the MP and the Functional ID has occurred for a 35-40 second period.	Remote
Comm Loss: Heating EXV	Circuit	Immediate	Latch	All	Continual loss of communication between the MP and the Functional ID has occurred for a 35-40 second period.	Remote
Comm Loss: High Pressure Cutout Switch	Circuit	Immediate	Latch	All	Continual loss of communication between the MP and the Functional ID has occurred for a 35-40 second period.	Remote
Comm Loss: Noise Reduction Request Relay	Chiller	Normal	Latch	All	Continual loss of communication between the MP and the Functional ID has occurred for a 35-40 second period.	Remote
Comm Loss: Outdoor Air Temperature	Chiller	Normal	Latch	All	Continual loss of communication between the MP and the Functional ID has occurred for a 35-40 second period.	Remote
Comm Loss: Percent Capacity Output	Chiller	Warning	Latch	All	Continual loss of communication between the MP and the Functional ID has occurred for a 35-40 second period.	Remote

Table 41. Communication diagnostics (continued)

Diagnostic Name	Affects	Severity	Persistence	Active Modes [Inactive Modes]	Criteria	Reset Level
Comm Loss: Phase Protection Fault Input	Chiller	Normal	Latch	All	Continual loss of communication between the MP and the Functional ID has occurred for a 35-40 second period.	Remote
Comm Loss: Power Factor Correction Fault Input	Chiller	Warning	Latch	All	Continual loss of communication between the MP and the Functional ID has occurred for a 35-40 second period.	Remote
Comm Loss: Programmable Relay Board 1	Chiller	Warning	Latch	All	Continual loss of communication between the MP and the Functional ID has occurred for a 35-40 second period.	Remote
Comm Loss: Receiver Fill Valve Relay	Circuit	Normal	Latch	All	Continual loss of communication between the MP and the Functional ID has occurred for a 35-40 second period.	Remote
Comm Loss: Reversing Valve	Circuit	Normal	Latch	All	Continual loss of communication between the MP and the Functional ID has occurred for a 35-40 sec period.	Remote
Comm Loss: Run Command Compressor X	Cprsr	Immediate	Latch	All	Continual loss of communication between the MP and the Functional ID has occurred for a 35-40 second period.	Remote
Comm Loss: Subcooler Shutoff Valve Relay	Circuit	Normal	Latch	All	Continual loss of communication between the MP and the Functional ID has occurred for a 35-40 sec period.	Remote
Comm Loss: Suction Pressure Transducer	Circuit	Immediate	Latch	All	Continual loss of communication between the MP and the Functional ID has occurred for a 35-40 second period.	Remote
Comm Loss: Suction Temperature	Circuit	Immediate	Latch	All	Continual loss of communication between the MP and the Functional ID has occurred for a 35-40 second period.	Remote
Comm Loss: Supplemental Heater Relay 1	Chiller	Warning	Latch	All	Continual loss of communication between the MP and the Functional ID for relay 1 has occurred for a 35-40 second period.	Remote
Comm Loss: Supplemental Heater Relay 2	Chiller	Warning	Latch	All	Continual loss of communication between the MP and the Functional ID for relay 2 has occurred for a 35-40 second period.	Remote
Comm Loss: Supplemental Heater Relay 3	Chiller	Warning	Latch	All	Continual loss of communication between the MP and the Functional ID for relay 3 has occurred for a 35-40 second period.	Remote
Comm Loss: Supplemental Heater Relay 4	Chiller	Warning	Latch	All	Continual loss of communication between the MP and the Functional ID for relay 4 has occurred for a 35-40 second period.	Remote



Unit Wiring

Table below provides a list of 20 to 130 tons CGAM electrical schematics, field wiring and connection diagrams.

Wiring diagrams can be accessed via e-Library. A laminated wiring diagram kit is also shipped with each unit.

Description	Unit Frame	Document Number
Schematic	Slant S	2311-6150
	V	2311-6102
	W	2311-6020
Field Wiring	All	2311-6021
Field Layout	Slant S	5719-3885
	V	5719-3840
	W	5719-3609
Component Location (Panel)	Slant S	5719-3886
	V	5719-3841
	W	5719-3235
Component Location (Unit)	Slant s	5720-6497
	V	5720-6498
	W	5720-6499
Component Location (VSD Pump)	All	5722-4410



Log and Check Sheet

The check sheet is included for use as appropriate, for installation completion verification before Trane start-up is scheduled, and for reference during the Trane start-up.

Where the check sheet also exists outside of this publication as standalone literature, the literature order number is also listed.

CGAM Installation Completion Check Sheet and Request for Trane Service (CG-ADF011-EN).*

CGAM Air-Cooled Scroll Chiller Installation Completion Check Sheet and Request for Trane Service

Important: A copy of this completed form must be submitted to the Trane service agency that will be responsible for the start-up of the chiller. Start-up will NOT proceed unless applicable items listed in this form have been satisfactorily completed.

To: _____

Trane Service Office: _____

S.O. Number: _____

Serial Numbers: _____

Job/Project Name: _____

Address: _____

- Check this box if this unit contains an A2L refrigerant. Only an A2L Certified Technician can start this unit.

The following items are being installed and will be completed by: _____

Important:

- Start-up must be performed by Trane or an agent of Trane specifically authorized to perform start-up and warranty of Trane® products. Contractor shall provide Trane (or an agent of Trane specifically authorized to perform start-up) with notice of the scheduled start-up at least two weeks prior to the scheduled start-up.
- It is required that heaters are energized for a minimum of 24 hours prior to start-up. Therefore, chiller should have power for this amount of time before Trane Service arrives to do start-up.
- Review A2L Work Procedures chapter of Air-Cooled Scroll Chillers Model CGAM with Symbio™ Controls 20 to 130 Nominal Tons (60 Hz) Installation, Operation, and Maintenance (CG-SVX063*-EN) prior to initiating work.

Check boxes if the task is complete or if the answer is "yes".

1. CGAM Chiller

- Installation meets foundation requirements
- In place and piped.
- Isolation pads or neoprene pads installed

(optional).

- Magnetic green diamonds removed (if shipped with N2).

2. Piping

- Chilled water piping connected to:
 - Evaporator.
 - Heat recovery (if applicable).
 - Air handling units.
 - Pumps (no piping to pump required if optional pump package is installed).
 - Secondary flow proving device installed (recommended).
 - Strainer installed and cleaned.
 - Verify chilled water inlet vents and chilled water outlet drains are closed.

- Water supply connected to filling system.

- Does unit have freeze inhibitor? If unit has freeze inhibitor:

- Verify type and concentration correct per unit submittal.

- Calculate and record freeze point of the solution: _____

- Systems filled.

- Pumps run, air bled from system.

- Strainer cleaned.

Note: Do not remove strainer mesh to clean the system.

- Relief valve ventilation piping installed (if applicable).

- Flow balancing valves installed on:

- Leaving chilled water.

- Optional heat recovery (if applicable).

- Gauges, thermometers, and air vents installed on:

- Both sides of evaporator.

- Optional heat recovery (if applicable).

3. Wiring

- Wire size per submittal and NEC 310-16.

- Unit is properly grounded.

- Wiring connects are tight.

Note: Do not overtorque.

- Full power available, and within utilization range.

- Interconnecting wiring to control panel (as required).

- External interlocks (secondary proof of flow, pumps auxiliary, etc).

- Chilled water pump connected and tested (not required if optional pump package is installed).



Log and Check Sheet

- Heat recovery condenser water pump (as applicable).
- 115 Vac power available for service tools.
- All controls installed and connected.

4. Testing

- Trace gas amounts of R-454B available for leak testing, if necessary.

5. Refrigerant on job site, if unit shipped with nitrogen charge

- Dry nitrogen available for pressure testing.

6. Systems can be operated under load conditions

Important: Start-up cannot be completed without ability to fully load the unit.

7. Heaters

- Verify that the compressor oil sump heaters are installed tightly around the compressor. Energize and verify heaters are operational using a temperature probe.
- If unit was factory charged (model number digit 20 = 3), **energize heaters for 24 hours prior to start-up.**

Important: It is required that chiller heaters are energized for a minimum of 24 hours prior to start-up. Therefore, chiller should have power for this amount of time before Trane Service arrives to do start-up.

- If unit has nitrogen charge (model number digit 20 = 4), contact Trane Service for unit charging prior to start-up.

8. Owner awareness

- Does the owner have a copy of the MSDS for refrigerant?

Note: Additional time required to properly complete the start-up and commissioning, due to any incompleteness of the installation, will be invoiced at prevailing rates.

This is to certify that the Trane® equipment has been properly and completely installed, and that the applicable items listed above have been satisfactorily completed.

Important: It is required that the chiller heaters are energized for a minimum of 24 hours prior to start-up. Therefore, the chiller should have power for this amount of time before Trane Service arrives to do start-up of the equipment.

Checklist completed by: _____

Signed: _____

Date: _____

In accordance with your quotation and our purchase order number _____, we will therefore require the presence of Trane service on this site, for the purpose of start-up and commissioning, by _____ (date).

Note: Minimum two-week advance notification is required to allow scheduling of the chiller start-up.

Additional Comments/Instructions:

Note: A copy of this completed form must be submitted to the Trane Service Office that will be responsible for start-up of chiller.

Trane - by Trane Technologies (NYSE: TT), a global innovator - creates comfortable, energy efficient indoor environments for commercial and residential applications. For more information, please visit trane.com or tranetechnologies.com.

Trane has a policy of continuous product and product data improvements and reserves the right to change design and specifications without notice. We are committed to using environmentally conscious print practices.

CG-SVX063B-EN 17 Jan 2025
Supersedes CG-SVX063A-EN (November 2023)

©2025 Trane