



Installation, Operation, and Maintenance

Cold Generator™ Compact Chiller

Series

20 to 85 Tons (60 Hz)

R-410A



Model CICD

SAFETY WARNING

Only qualified personnel should install and service the equipment. The installation, starting up, and servicing of heating, ventilating, and air-conditioning equipment can be hazardous and requires specific knowledge and training. Improperly installed, adjusted or altered equipment by an unqualified person could result in death or serious injury. When working on the equipment, observe all precautions in the literature and on the tags, stickers, and labels that are attached to the equipment.

June 2022

CG-SVX044F-EN

TRANE
TECHNOLOGIES



Introduction

Read this manual thoroughly before operating or servicing this unit.

Warnings, Cautions, and Notices

Safety advisories appear throughout this manual as required. Your personal safety and the proper operation of this machine depend upon the strict observance of these precautions.

The three types of advisories are defined as follows:

- ⚠ WARNING** Indicates a potentially hazardous situation which, if not avoided, could result in death or serious injury.
- ⚠ CAUTION** Indicates a potentially hazardous situation which, if not avoided, could result in minor or moderate injury. It could also be used to alert against unsafe practices.
- NOTICE** Indicates a situation that could result in equipment or property-damage only accidents.

Important Environmental Concerns

Scientific research has shown that certain man-made chemicals can affect the earth's naturally occurring stratospheric ozone layer when released to the atmosphere. In particular, several of the identified chemicals that may affect the ozone layer are refrigerants that contain Chlorine, Fluorine and Carbon (CFCs) and those containing Hydrogen, Chlorine, Fluorine and Carbon (HCFCs). Not all refrigerants containing these compounds have the same potential impact to the environment. Trane advocates the responsible handling of all refrigerants-including industry replacements for CFCs and HCFCs such as saturated or unsaturated HFCs and HCFCs.

Important Responsible Refrigerant Practices

Trane believes that responsible refrigerant practices are important to the environment, our customers, and the air conditioning industry. All technicians who handle refrigerants must be certified according to local rules. For the USA, the Federal Clean Air Act (Section 608) sets forth the requirements for handling, reclaiming, recovering and recycling of certain refrigerants and the equipment that is used in these service procedures. In addition, some states or municipalities may have additional requirements that must also be adhered to for responsible management of refrigerants. Know the applicable laws and follow them.

⚠ WARNING

Proper Field Wiring and Grounding Required!

Failure to follow code could result in death or serious injury. All field wiring **MUST** be performed by qualified personnel. Improperly installed and grounded field wiring poses **FIRE** and **ELECTROCUTION** hazards. To avoid these hazards, you **MUST** follow requirements for field wiring installation and grounding as described in NEC and your local/state/national electrical codes.

⚠ WARNING

Personal Protective Equipment (PPE) Required!

Failure to wear proper PPE for the job being undertaken could result in death or serious injury. Technicians, in order to protect themselves from potential electrical, mechanical, and chemical hazards, **MUST** follow precautions in this manual and on the tags, stickers, and labels, as well as the instructions below:

- Before installing/servicing this unit, technicians **MUST** put on all PPE required for the work being undertaken (Examples; cut resistant gloves/sleeves, butyl gloves, safety glasses, hard hat/bump cap, fall protection, electrical PPE and arc flash clothing). **ALWAYS** refer to appropriate Safety Data Sheets (SDS) and OSHA guidelines for proper PPE.
- When working with or around hazardous chemicals, **ALWAYS** refer to the appropriate SDS and OSHA/GHS (Global Harmonized System of Classification and Labeling of Chemicals) guidelines for information on allowable personal exposure levels, proper respiratory protection and handling instructions.
- If there is a risk of energized electrical contact, arc, or flash, technicians **MUST** put on all PPE in accordance with OSHA, NFPA 70E, or other country-specific requirements for arc flash protection, **PRIOR** to servicing the unit. **NEVER PERFORM ANY SWITCHING, DISCONNECTING, OR VOLTAGE TESTING WITHOUT PROPER ELECTRICAL PPE AND ARC FLASH CLOTHING. ENSURE ELECTRICAL METERS AND EQUIPMENT ARE PROPERLY RATED FOR INTENDED VOLTAGE.**

⚠ WARNING**Follow EHS Policies!**

Failure to follow instructions below could result in death or serious injury.

- All Trane personnel must follow the company's Environmental, Health and Safety (EHS) policies when performing work such as hot work, electrical, fall protection, lockout/tagout, refrigerant handling, etc. Where local regulations are more stringent than these policies, those regulations supersede these policies.
- Non-Trane personnel should always follow local regulations.

Copyright

This document and the information in it are the property of Trane, and may not be used or reproduced in whole or in part without written permission. Trane reserves the right to revise this publication at any time, and to make changes to its content without obligation to notify any person of such revision or change.

Trademarks

All trademarks referenced in this document are the trademarks of their respective owners.

Revision History

- Updated Model Number Description chapter.
- Updated table values in the General Data, Electrical Data, Dimensions and Weights and Installation Mechanical chapters.
- Minor updates to document.



Table of Contents

Model Number Descriptions	5	Unit Start-Up Procedures	35
General Information	7	Pre-Start	35
Unit Description	7	Sequence of Operation	35
General Data	7	Checking Operating Conditions	36
Pre-Installation	9	System Superheat	36
Electrical Data	10	System Subcooling	36
Dimensions and Weights	11	Shut Down	37
Dimensions	11	Normal Unit Shutdown	37
Clearances	17	Extended Shutdown Procedure	37
Weights	20	Unit Restart	38
Installation Mechanical	21	Maintenance	39
General Installation Information	21	Periodic Maintenance	39
Storage	21	Compressor Maintenance	39
Noise Considerations	21	Heat Exchanger Maintenance	40
Foundation	21	Wiring	42
Clearances	22	Appendix A	53
Ventilation	22	Warranty	53
Drainage	22	Appendix B	55
Handling	22	Piping System Flushing Procedure	55
Access Restrictions	23	Water Treatment Requirements	55
Compressor Mounting	23		
Direct Mounting	23		
Unit Leveling	23		
Typical Water Piping	23		
Avoidance of Short Water Loops	23		
Minimum Water Volume for a Process Application	24		
Unit Piping	24		
Installation Electrical	30		
General Recommendations	30		
Equipment Grounding	31		
Unit Power Wiring	31		
Control Power Supply	32		
External Contacts and Peripherals	32		
Controls Interface	33		
Unit Controller — General	33		
Unit Controller			
Software Installation and Setup	33		



Model Number Descriptions

Digits 1 to 4 — Model

CICD= Compact Indoor Chiller

Digits 5 to 7 — Nominal Capacity

020 = 20 Nominal Tons
030 = 30 Nominal Tons
045 = 45 Nominal Tons
055 = 55 Nominal Tons
065 = 65 Nominal Tons
075 = 75 Nominal Tons
085 = 85 Nominal Tons

Digit 8 — Unit Voltage

A = 208 V/60 Hz/3 Phase
B = 230 V/60 Hz/3 Phase
F = 460 V/60 Hz/3 Phase
G = 575 V/60 Hz/3 Phase

Digits 9 — Unit Application

A = Water-Cooled Chiller
B = Compressor Chiller with Remote Condenser (40°F to 115°F)
D = Compressor Chiller with Remote Condenser (20°F)

Digit 10 — Refrigeration Style

A = R-410A Scroll

Digit 11 — Number of Circuits

1 = Single Circuit
2 = Dual Circuit

Digit 12 — Efficiency/Capacity

1 = Standard Efficiency
2 = High Capacity Evaporator (Allows 40°F leaving water)

Digit 13 — Design Sequence

0 = Factory Assigned

Digit 14 — Array System

0 = Non-Array System
1 = Array System

Digit 15 — Evaporator Heat

Exchanger Type

0 = Brazed Plate

Digit 16 — Evaporator Fluid Type

0 = Water
2 = Ethylene Glycol
3 = Propylene Glycol

Digit 17 — Evaporator Flow

0 = Constant Flow Primary
1 = Variable Flow Primary

Digit 18 — Evaporator Temperature Range

0 = Standard Cooling 40 to 65°F [5.5 to 18.3°C]
1 = Standard Cooling/Ice Making 20 to 65°F [-6.7 to 18.3°C]
2 = Low Temperature Glycol Process (10 to 42°F) [-12.2 to 5.5°C]

Digit 19 — Evaporator Control Valves

0 = Manual Balancing Isolating Valves
1 = Motorized Chilled Water Isolating Valve

Digit 20 — Condenser Heat

Exchanger Type

0 = Brazed Plate
1 = Shell and Tube
5 = Remote Condenser

Digit 21— Condenser Fluid Type

0 = Water
2 = Ethylene Glycol
3 = Propylene Glycol
9 = Not Applicable — Compressor-Chiller

Digit 22 — Condenser Heat Recovery

0 = No Heat Recovery
1 = Full Heat Recovery with Auto Changeover

Digit 23 — Condenser Corrosion Resistance

0 = Standard
1 = Cupro-Nickel (Avail. Shell and Tube Only)

Digit 24 — Condenser Control Valves

1 = Manual Valve
2 = Motorized Head Pressure Control Valve

Digit 25 — Power Feed

0 = Single Point Power (5 kA Rating)
A = Single Point Power (5 kA Rating) + Phase and Voltage Monitor
B = Single Point Power (100 kA Rating)
C = Single Point Power (100 kA Rating) + Phase and Voltage Monitor
D = Power Feed to Each Unit (5 kA Rating)
E = Power Feed to Each Unit (5 kA Rating) + Phase and Voltage Monitor
F = Power Feed to Each Unit (100 kA Rating)
G = Power Feed to Each Unit (100 kA Rating) + Phase and Voltage Monitor

Digit 26 — Power Connection

0 = Terminal Block
A = Non-Fused Disconnect Switch
B = Fused Disconnect Switch
C = High SCCR Fuse Block
D = Distribution Panel Connection = Terminal Block; Module Power Connection = Circuit Breaker

Digit 27 — Service Options

0 = None
A = LED Lighted Control Cabinet

Digit 28 — Panel Ampere Rating

0 = None
D = 250 Amp
E = 400 Amp
F = 600 Amp
G = 800 Amp
H = 1200 Amp

Digit 29 — Control Style

0 = Manager Subordinate Controller with Single Controller per Array
A = Supervisory Array Controller with Controller per Module
B = Non-Array, Single Unit Controller

Digit 30 — Local Unit Controller Interface

0 = Keypad with Dot Pixel Display
B = 15.4-in. Color Touchscreen

Digit 31 — Remote BMS Interface (Digital Comm)

0 = None
2 = Lon Talk®
4 = BACnet® MS/TP
5 = BACnet® IP
6 = MODBUS®
8 = Johnson N2

Digit 32 — Blank

0 = Blank

Digit 33 — Blank

0 = Blank

Digit 34 — Refrigeration Options

1 = Active Freeze Protection (All Circuits)
2 = Hot Gas Bypass (All Circuits)

Digit 35 — Refrigeration Accessories

0 = Moisture Indicating Sight Glass
A = Moisture Indicating Sight Glass + Compressor Isolation Valves
B = Moisture Indicating Sight Glass + Replaceable Core Filter Driers
C = Moisture Indicating Sight Glass + Replaceable Core Filter Driers + Compressor Isolation Valves

Digit 36 — Water Connection

0 = Grooved Pipe Connection, Standard Header Length
A = Grooved Pipe Connection, Extended Header Length
D = No Header Piping (Heat Exchangers Only)

Digit 37 — Water Side Pressure

0 = 150 psi
A = 300 psi



Model Number Descriptions

Digit 38 — Water Strainer(s)

- 0 = None
- A = Chilled Water Flow Wye Strainer
- B = Chilled Water Wye Strainer with Installation Kit
- C = Condenser Water Flow Wye Strainer
- D = Condenser Water Wye Strainer with Installation Kit
- E = Chilled and Condenser Water Nominal Flow Wye Strainer
- F = Chilled and Condenser Water Wye Strainer with Installation Kit

Digit 39 — Water Accessories

- 0 = Chilled Water Flow Switch
- A = Condenser Water Flow Switch
- B = Analog Water Temperature Gauge
- C = Analog Water Pressure Gauge
- D = Chilled Water Flow Switch + Condenser Water Flow Switch
- E = Chilled Water Flow Switch + Analog Water Temperature Gauge
- F = Chilled Water Flow Switch + Analog Water Pressure Gauge
- G = Chilled Water Flow Switch + Condenser Water Flow Switch + Analog Water Temperature Gauge
- H = Chilled Water Flow Switch + Condenser Water Flow Switch + Analog Water Pressure Gauge
- J = Chilled Water Flow Switch + Analog Water Temperature Gauge + Analog Water Pressure Gauge
- K = Chilled Water Flow Switch + Condenser Water Flow Switch + Analog Water Temperature Gauge + Analog Water Pressure Gauge

Digit 40 — Blank

- 0 = Blank

Digit 41 — Sound Attenuator

- 0 = None
- A = Compressor Sound Blankets
- B = Factory Sound Enclosure Cabinet
- C = Compressor Sound Blankets + Factory Sound Enclosure Cabinet

Digit 42 — Unit Mounting

- 0 = None
- A = Neoprene Pads
- B = Leveling Kit
- C = Casters/Wheels
- D = Neoprene Pads and Casters
Wheels
- E = Neoprene Pads and Leveling Kit

Digit 43 — Exterior Finish and Shipping Splits

- 0 = Standard Paint, Each Module
Packaged Separately
- B = Custom Paint, Each Module
Packaged Separately

Digit 44 — Shipping Options

- A = Framed Crate with Plastic Wrap
(Non-Shrink)
- D = Fully Enclosed Crate

Digit 45 — Warranty

- 0 = Standard Warranty

Digit 46 — Special Options

- 0 = None
- X = With Specials



General Information

Unit Description

Model CICD Cold Generator™ Compact Series water-cooled chillers are designed for installation on a prepared surface in a suitable, weatherproof location above freezing (32°F). Each unit consists of one or two independent refrigerant circuits, two scroll compressors, a single or dual circuited brazed plate evaporator, a single or dual circuited brazed plate or shell-and-tube condenser and control box with integral control panel—all mounted on a common frame.

Each unit is a completely assembled package that is factory-piped, wired, leak-tested, dehydrated, charged and run-tested for proper control operation before shipment. Water inlet and outlet openings are covered before shipment. CICD units are shipped with an operating charge of refrigerant and oil.

General Data

Table 1. General data

Size			20	30	45	55	65	75	85
Compressor									
	Quantity		2	2	2	2	2	2	2
	Nominal Tons @ 60 Hz	tons	10/10	15/15	20/20	25/25	30/30	30/40	40/40
	Compressor Sound Data	dbA	81	84	89	89	92	93.1	94
	Compressor Sound Data with Sound Blankets Only ^(a)	dbA	75	78	85	85	88	89.1	90
Evaporator									
	Water Storage	gal	9	10	11	12	13	14	14
	Minimum Flow	gpm	30	30	40	45	55	60	75
	Maximum Flow	gpm	150	150	245	245	250	275	275
Brazed Plate Condenser									
	Water Storage	gal	10	11	11	12	13	14	14
	Minimum Flow	gpm	50	50	70	85	105	115	135
	Maximum Flow	gpm	150	150	245	245	250	275	275
Shell and Tube Condenser									
	Water Storage	gal	9	9	9	9	10	10	12
	Minimum Flow	gpm	35	35	60	60	85	85	105
	Maximum Flow	gpm	150	150	245	245	250	250	250

(a) Compressor manufacturer sound power is given at rated compressor AHRI conditions measured in free space for tandem compressor sets.

Unit Components

Figure 1. Unit components

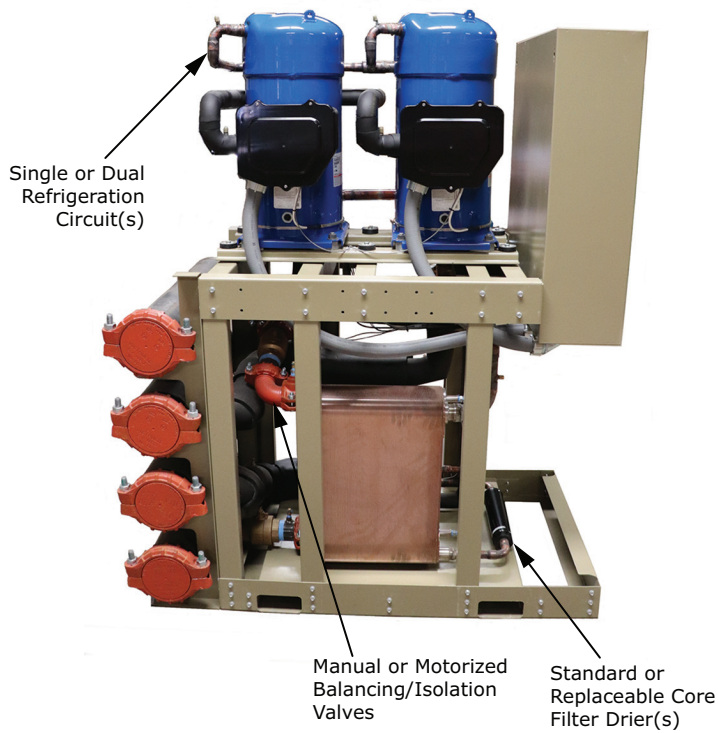
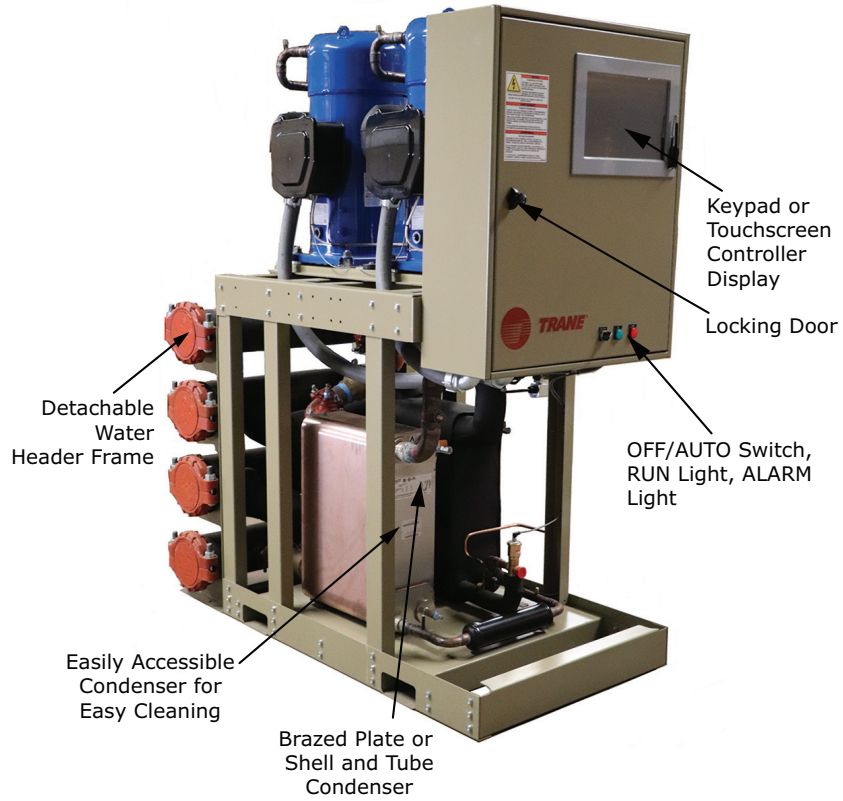



Pre-Installation

To protect against loss due to damage incurred in transit, complete the following checklist upon receipt of the unit. A more in depth list is included with the packing list adhered to the side of the shipping crate.

- Inspect the individual pieces of the shipment before accepting the unit. Check for obvious damage to the unit or packing material.
- Inspect the unit for concealed damage as soon as possible after delivery and before it is stored. Concealed damage must be reported within 15 days.
- If concealed damage is discovered, stop unpacking the shipment. Do not remove damaged material from the receiving location. Take photos of the damage, if possible. The owner must provide reasonable evidence that the damage did not occur after delivery.
- Notify the carrier's terminal of the damage immediately, by phone and by mail. Request an immediate, joint inspection of the damage with the carrier and the consignee.
- Notify the Trane sales representative and arrange for repair. However, do not repair the unit until damage is inspected by the carrier's representative.

After completing the inspection checklist, identify the unit with the unit nameplate, packing list and ordering information. The unit nameplate is mounted inside the control box.

See "[Model Number Descriptions](#)," p. 5 for additional data that can be found on the nameplate.

Check all items against the shipping list. Verify that it is the correct unit and that it is properly equipped. If optional neoprene pads (or other ship-loose items) are ordered, they are secured in place on the shipping skid or inside the unit control box.

This Installation, Operation and Maintenance manual, the Controls IOM, checklists and other pertinent documents can also be found in the unit control box. Be sure to read all of this literature before installing and operating the unit.



Electrical Data

Table 2. Electrical data

Size	Rated Voltage	Compressor					Wiring		
		Qty	# of Refrigerant Circuits	Nominal Tons	RLA (each)	LRA (each)	Minimum Circuit Ampacity	Max Fuse Size	Recommended Dual Element Fuse Size
20	200-230/60/3	2	1 or 2	10/10	39	267	88	125	100
	460/60/3				19	142	42	60	50
	575/60/3				15	103	35	50	40
30	200-230/60/3	2	1 or 2	15/15	48	351	108	150	125
	460/60/3				25	197	56	80	60
	575/60/3				22	135	50	70	60
45	200-230/60/3	2	1 or 2	20/20	67	485	151	200	175
	460/60/3				33	215	74	100	80
	575/60/3				26	175	59	80	70
55	200-230/60/3	2	1 or 2	25/25	82	560	185	250	225
	460/60/3				40	260	89	125	100
	575/60/3				29	210	65	90	70
65	200-230/60/3	2	1 or 2	30/30	109	717	245	350	250
	460/60/3				51	320	114	150	125
	575/60/3				38	235	87	125	100
75	200-230/60/3	2	1 or 2	30/40	109/122	717/1010	261	300	300
	460/60/3				51/68	320/344	136	200	150
	575/60/3				38/46	235/327	95	125	110
85	200-230/60/3	2	1 or 2	40/40	122	1010	274	350	300
	460/60/3				68	344	153	200	175
	575/60/3				46	327	102	125	125

Notes:

1. Use copper conductors only.
2. Local codes may take precedence.
3. Voltage Utilization Range: ± 10% of rated voltage. Rated voltage (use range): 200-230/60/3 (180-253), 460/60/3 (414-506), 575/60/3 (517-632).



Dimensions and Weights

Dimensions

Figure 2. CICD unit dimensions, brazed plate condenser

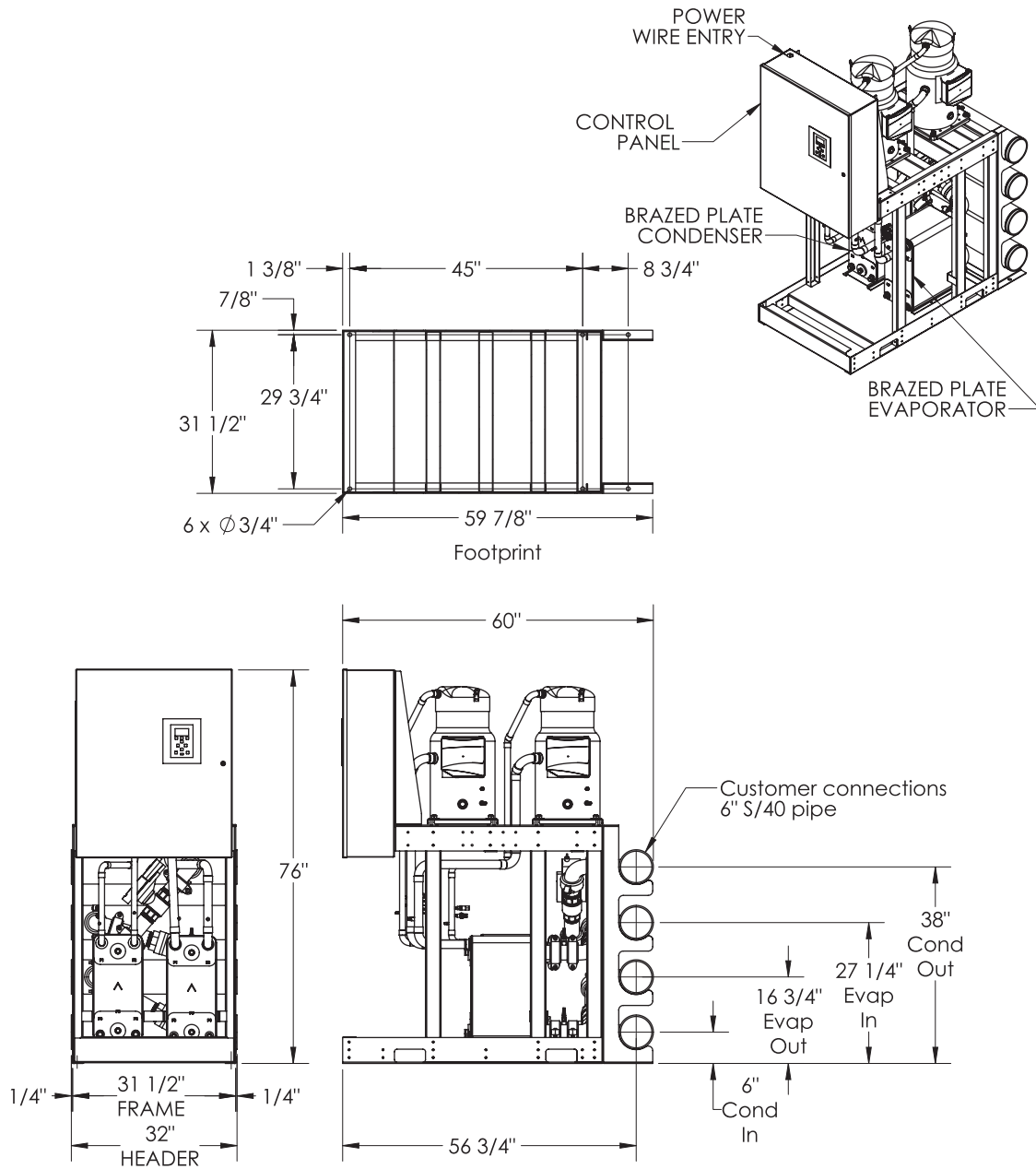



Dimensions and Weights

Figure 3. CICD unit array dimensions, brazed plate condenser

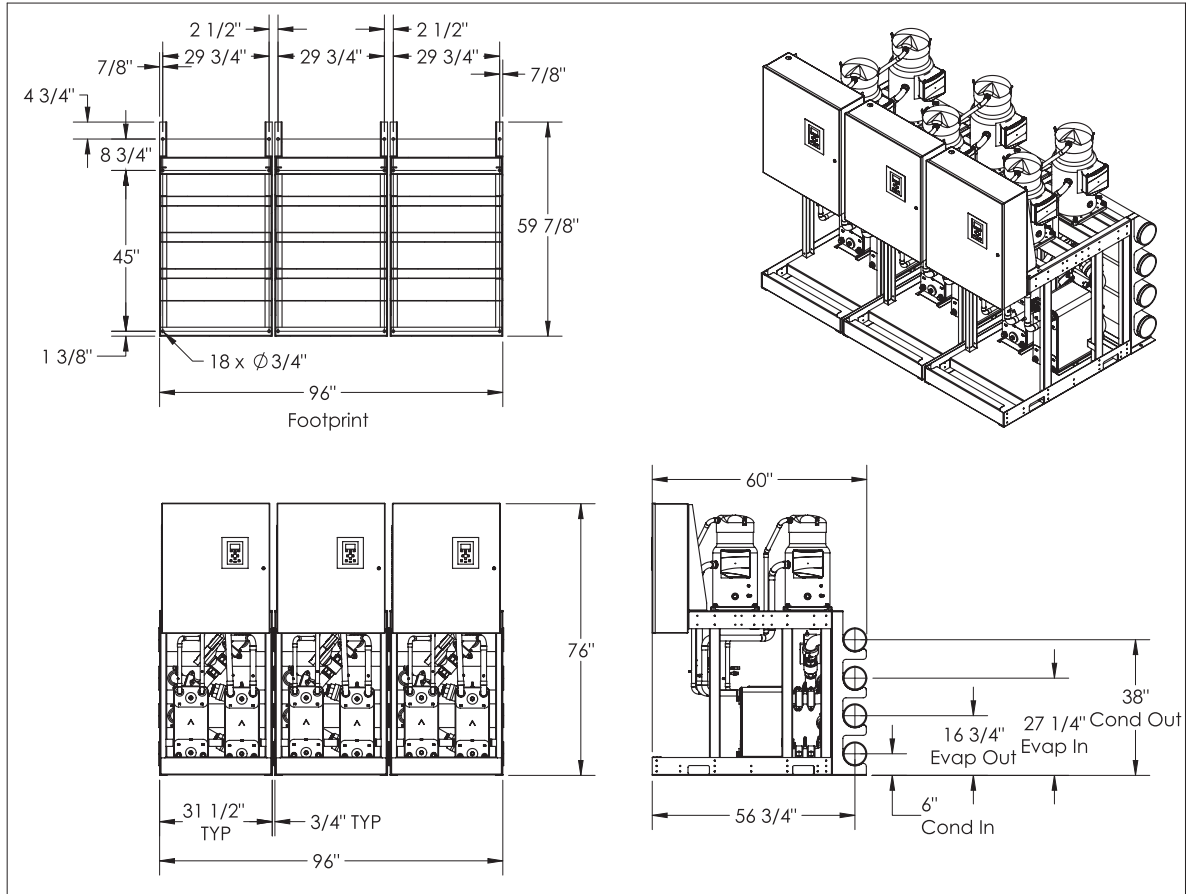
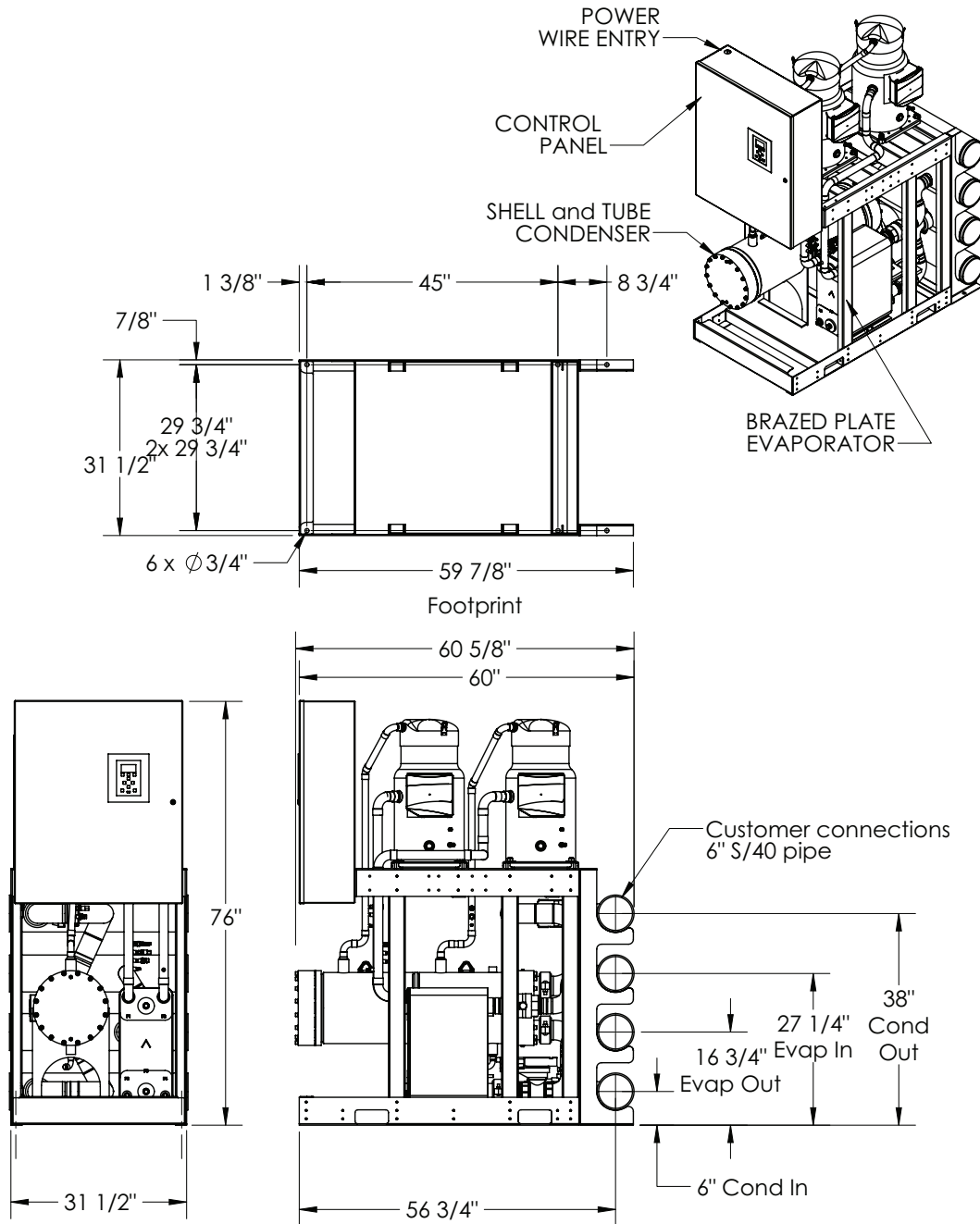

Figure 4. CICD unit dimensions, shell and tube condenser



Dimensions and Weights

Figure 5. CICD unit array dimensions, shell and tube condenser

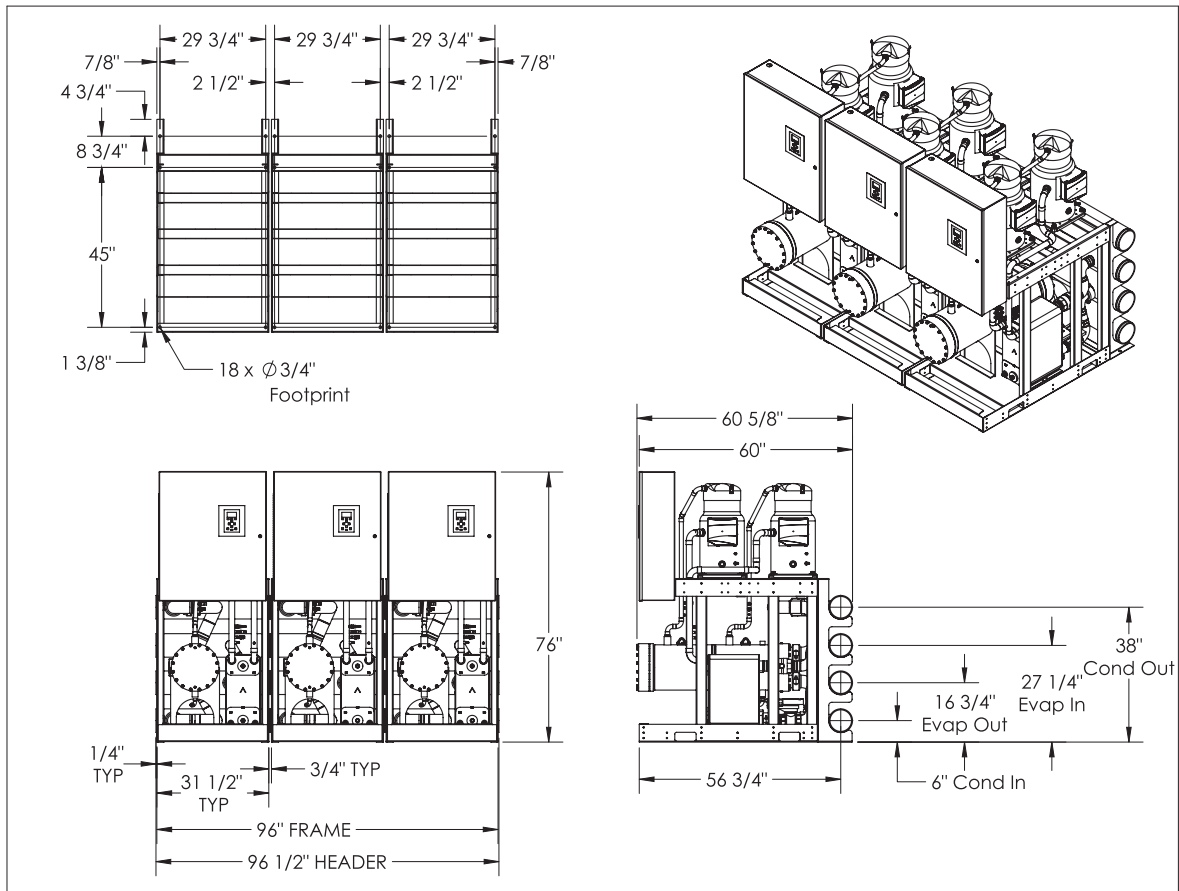
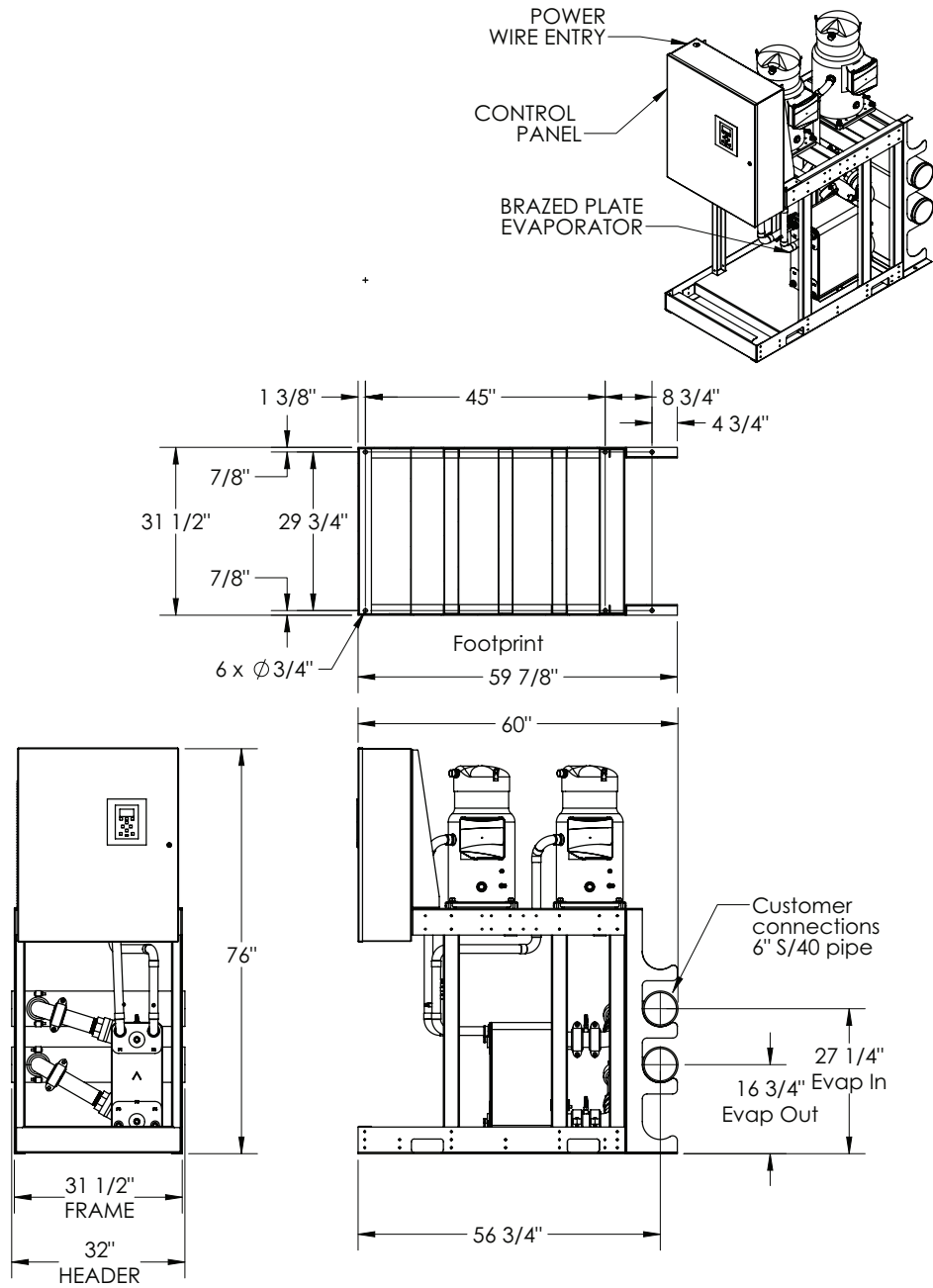

Figure 6. CICD unit dimensions, remote condenser





Dimensions and Weights

Figure 7. CICD unit array dimensions, remote condenser

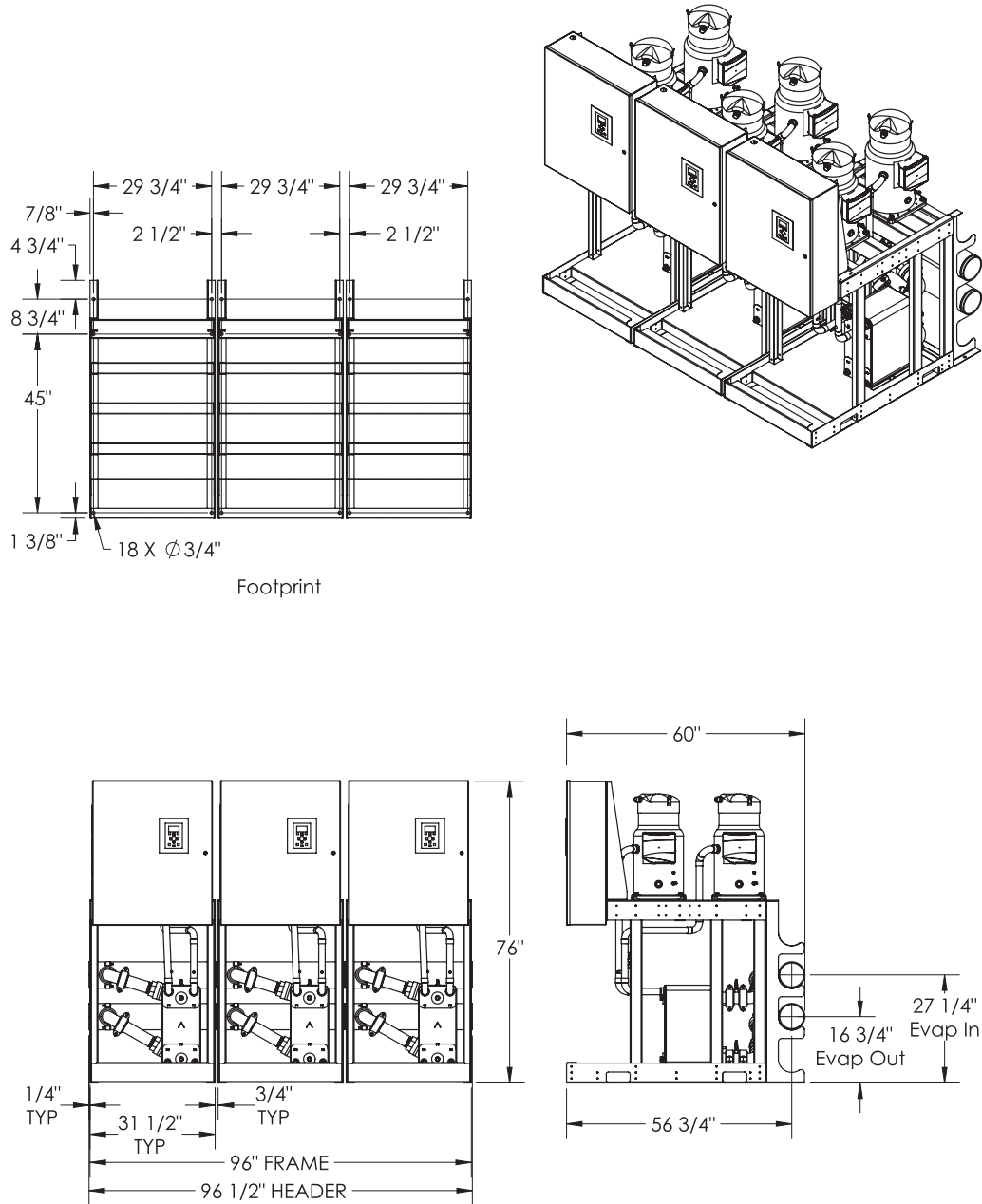

Clearances

Notes:

- Clearance of 42 inch is required in front of chiller to other electrically grounded parts.

- Two units facing each other or other live parts require a clearance of 48 inch.
- 36 inch clearance is recommended above the chiller.
- See [Figure 9](#) and [Figure 10, p. 18](#) for recommended clearance requirements for array installations.

Figure 8. Clearance — CICD single chiller application (all condenser options)

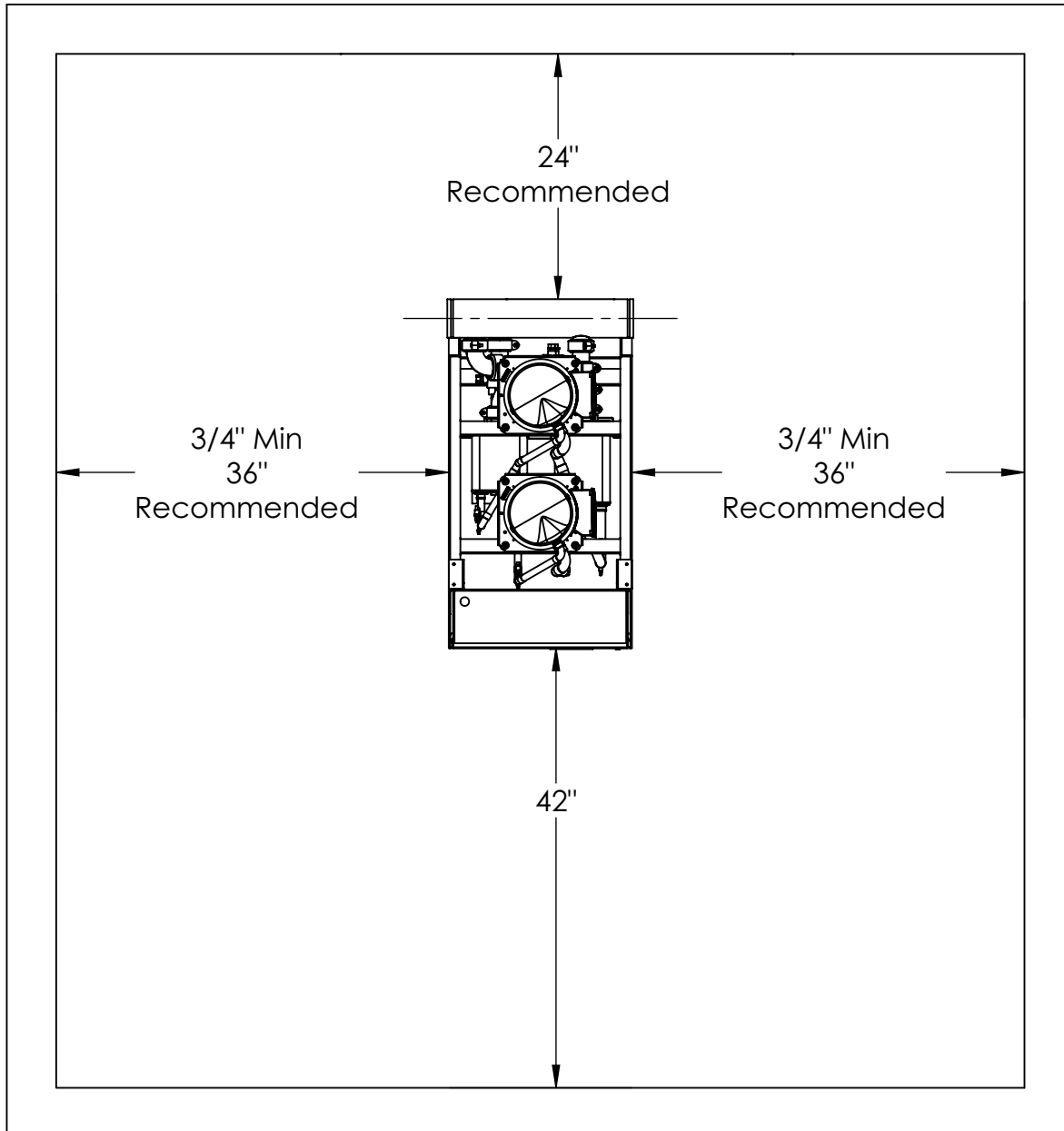

Dimensions and Weights

Figure 9. Clearance — CICD array chiller application (all condenser options)

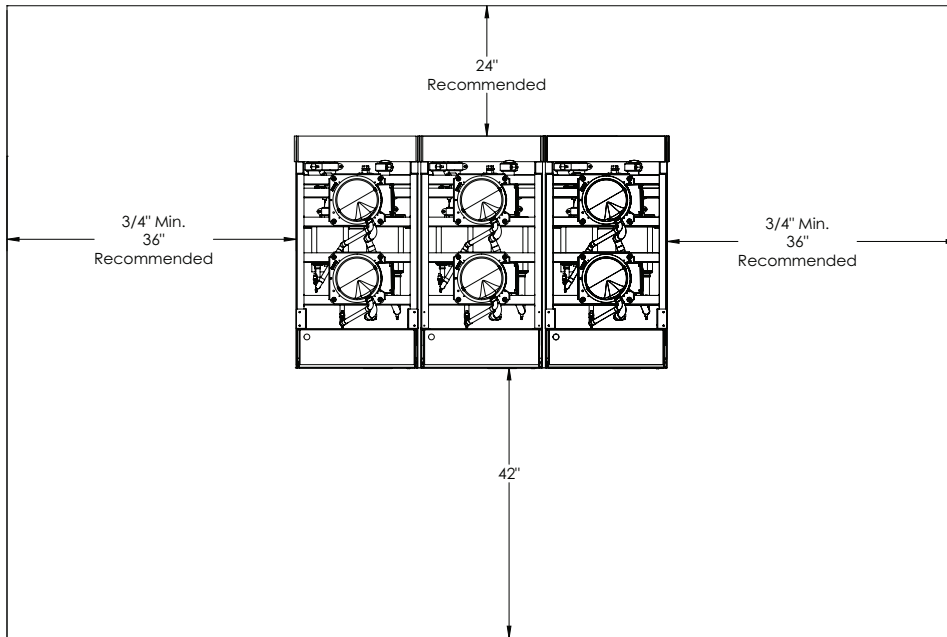

**Figure 10. Clearance needed to remove chiller from array—
CICD array chiller application (all condenser options)**

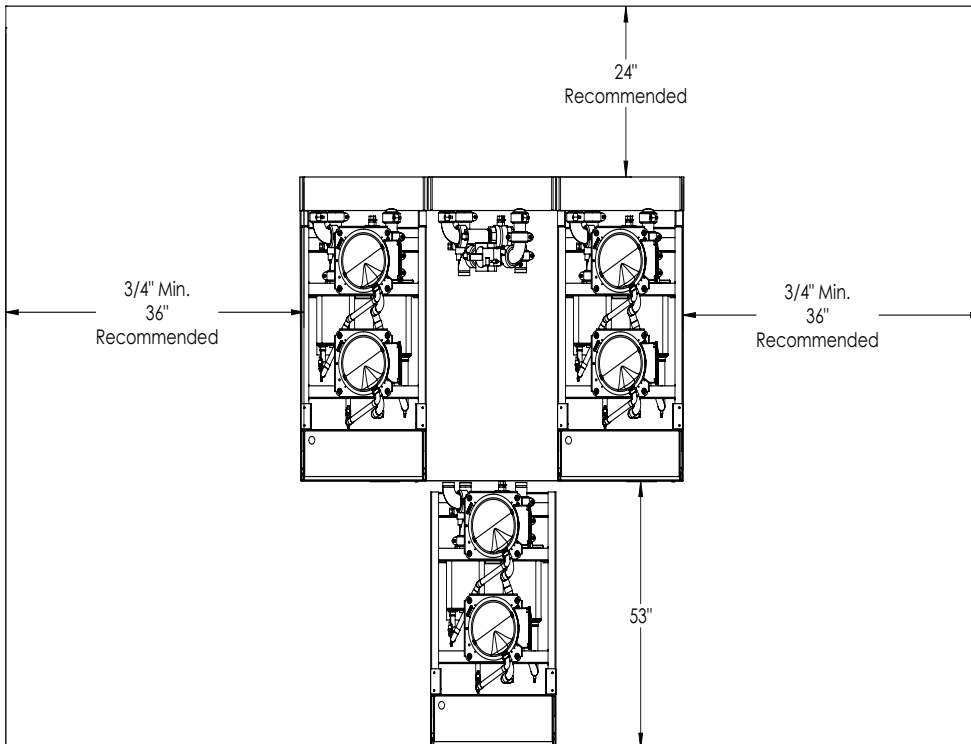
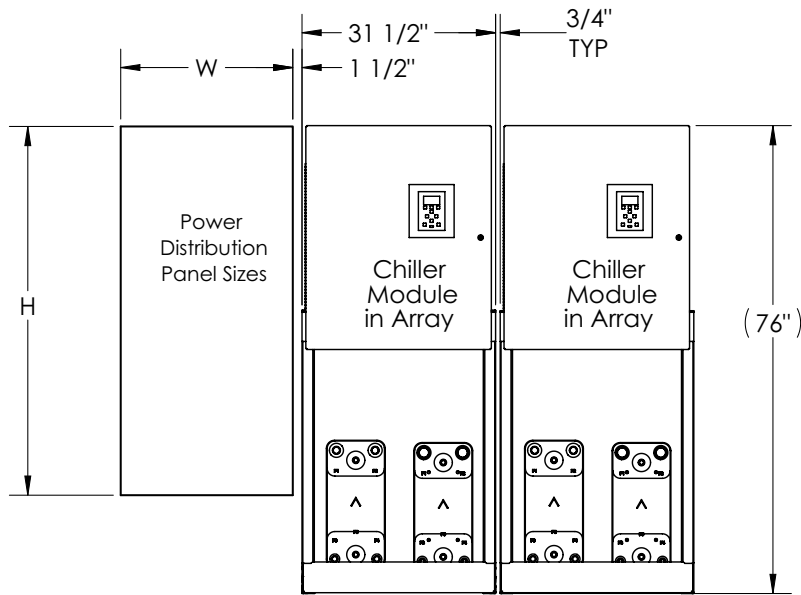

Figure 11. Single point power distribution panel dimensions

Array Single Point Power



Use chart below to determine panel size

Model	Electrical Power	2 Modules			3 Modules			4 Modules			5 Modules			6 Modules			7 Modules			8 Modules		
		H	W	D	H	W	D	H	W	D	H	W	D	H	W	D	H	W	D	H	W	D
CICD030	200-230/3/60	48.0	20.0	5.75	60.0	20.0	5.75	60.0	20.0	5.75	60.0	20.0	5.75	57.0	24.0	10.40	57.0	24.0	10.40	73.5	36.0	10.40
	460/3/60	36.0	20.0	5.75	36.0	20.0	5.75	36.0	20.0	5.75	48.0	20.0	5.75	48.0	20.0	5.75	48.0	20.0	5.75	48.0	20.0	5.75
	575/3/60	36.0	20.0	5.75	36.0	20.0	5.75	36.0	20.0	5.75	48.0	20.0	5.75	48.0	20.0	5.75	48.0	20.0	5.75	48.0	20.0	5.75
CICD045	200-230/3/60	60.0	20.0	5.75	60.0	20.0	5.75	72.0	28.0	5.75	72.0	28.0	5.75	73.5	36.0	10.40	73.5	36.0	10.40	N/A	N/A	N/A
	460/3/60	36.0	20.0	5.75	36.0	20.0	5.75	36.0	20.0	5.75	48.0	20.0	5.75	48.0	20.0	5.75	48.0	20.0	5.75	48.0	20.0	5.75
	575/3/60	36.0	20.0	5.75	36.0	20.0	5.75	36.0	20.0	5.75	48.0	20.0	5.75	48.0	20.0	5.75	48.0	20.0	5.75	48.0	20.0	5.75
CICD055	200-230/3/60	48.0	20.0	5.75	60.0	20.0	5.75	72.0	28.0	5.75	73.5	36.0	10.40	73.5	36.0	10.40	N/A	N/A	N/A	N/A	N/A	N/A
	460/3/60	36.0	20.0	5.75	36.0	20.0	5.75	36.0	20.0	5.75	48.0	20.0	5.75	48.0	20.0	5.75	48.0	20.0	5.75	48.0	20.0	5.75
	575/3/60	36.0	20.0	5.75	36.0	20.0	5.75	36.0	20.0	5.75	48.0	20.0	5.75	48.0	20.0	5.75	48.0	20.0	5.75	48.0	20.0	5.75
CICD065	200-230/3/60	73.5	36.0	10.40	73.5	36.0	10.40	73.5	36.0	10.40	73.5	36.0	10.40	N/A	N/A	N/A	N/A	N/A	N/A	N/A	N/A	N/A
	460/3/60	36.0	20.0	5.75	48.0	20.0	5.75	48.0	20.0	5.75	48.0	20.0	5.75	57.0	24.0	10.40	73.5	36.0	10.40	73.5	36.0	10.40
	575/3/60	36.0	20.0	5.75	36.0	20.0	5.75	36.0	20.0	5.75	48.0	20.0	5.75	48.0	20.0	5.75	57.0	24.0	10.40	57.0	24.0	10.40
CICD075	200-230/3/60	73.5	36.0	10.40	73.5	36.0	10.40	73.5	36.0	10.40	73.5	36.0	10.40	N/A	N/A	N/A	N/A	N/A	N/A	N/A	N/A	N/A
	460/3/60	36.0	20.0	5.75	48.0	20.0	5.75	48.0	20.0	5.75	48.0	20.0	5.75	57.0	24.0	10.40	73.5	36.0	10.40	73.5	36.0	10.40
	575/3/60	36.0	20.0	5.75	36.0	20.0	5.75	36.0	20.0	5.75	48.0	20.0	5.75	48.0	20.0	5.75	57.0	24.0	10.40	57.0	24.0	10.40

Note

Contact your local Trane representative if array total amps exceeds 1200 amps.



Dimensions and Weights

Weights

Table 3. CICD unit weights

Size	Shipping Weight						Operating Weight					
	Braze Plate Condenser		Shell-and-Tube Condenser		Remote Condenser		Braze Plate Condenser		Shell-and-Tube Condenser		Remote Condenser	
	lbs	kg	lbs	kg	lbs	kg	lbs	kg	lbs	kg	lbs	kg
20	1326	601	1467	665	1069	485	1525	692	1688	766	1168	530
30	1495	678	1760	798	1205	547	1720	780	2025	919	1320	599
45	1775	805	1970	894	1420	644	2040	925	2265	1027	1550	703
55	1795	814	1970	894	1410	639	2065	937	2265	1027	1545	701
65	2230	1012	2640	1197	1770	803	2565	1163	3035	1377	1940	880
75	2235	1014	2640	1197	1775	805	2570	1166	3035	1377	1945	882
85	2487	1128	2925	1327	1963	890	2860	1297	3362	1525	2152	976



Installation Mechanical

General Installation Information

- Please read and take heed of the water piping system flushing procedure and water treatment requirements found in “Appendix B,” p. 55 that are necessary to prepare and maintain an efficient and healthy chiller system that utilizes brazed plate heat exchangers.
 - Valves in the water piping upstream and downstream of the evaporator and condenser are installed on each CICD chiller to isolate the heat exchangers for maintenance and to balance/trim the system.
 - Supply and install condenser water control valve(s). See also Trane publication RLC-PRB021-EN, available from Trane Sales Offices, for additional technical assistance. Provisions must be made for the control of condenser water that results in stable saturated condensing temperature between 80°F and 145°F through all steady state, part load and transient operating conditions. Trane recommends the optional factory-installed integral water regulating valve controlled by the unit controller.
 - Supply and install flow switch or other approved flow proving device in the chilled water piping. Interlock this switch with the controller to ensure that the unit can only operate when water flow is established. See wiring diagram for connection point. A switch may be ordered with the unit if desired. It will be shipped loose for field installation.
 - When appropriate and needed, supply and install drain valves and vent cocks in the water system piping. Evaporator vent cocks are factory-installed on all CICD chillers.
 - Where specified, supply and install strainers ahead of all pumps and control valves.
- Note:** *CICD chillers may be ordered with cleanable, factory-selected wye-strainers to be installed in the field by others for protection of the brazed plate evaporators.*
- Supply and install suitable refrigerant pressure relief piping to the atmosphere if required. Follow ANSI/ASHRAE 15 guidelines, relief manufacturer’s guidelines, and industry standards when working with relief valve, fusible plugs and/or piping.
 - Start the unit under supervision of a qualified service technician.
 - Where specified, supply and insulate the chilled water piping as required, to prevent sweating under normal operating conditions. Trane provides factory insulation on evaporator and related components.

Storage

NOTICE

Store Units Above Freezing!

Store these units in a protected area above freezing (32°F) only. Do not store outdoors with a protective covering such as a plastic shroud. This can result in excessive water condensation that could damage controls and other components.

Noise Considerations

Locate the unit away from sound-sensitive areas. If necessary, install isolators under the unit. Install vibration isolators in all piping and use flexible electrical conduit. Consult an acoustical engineer for critical applications.

Foundation

A base or foundation is recommended for most installations. Provide a level surface strong enough to support the unit. See Dimension and Weights chapter for dimensions and weights. A flexible (isolated) concrete foundation or footings at each loading point will reduce transmission of vibration. Install anchor bolts in the concrete to secure the unit.

Note: *Use only anchor bolts that are flush with the top of the foundation, not a drive in stud type. An example of an acceptable anchor bolt is Red Head – Multi-Set II Drop In Shell Type. Using a flush type anchor bolt will make removal of a unit easier if required.*

If the floor is warped, uneven or in poor condition, make necessary repairs before positioning the unit. Once the unit is in place, it should be level within 1/8 inch side-to-side (width) and 1/8 inch front-to-back (depth).

Clearances

Provide adequate space around each unit for unrestricted access for installation and maintenance. Unit dimensions are given in the Dimensions and Weights chapter. It is critical that adequate space is provided for service and maintenance of evaporator, condenser and compressor. A minimum of 36 inches above the unit is recommended for effective compressor service. A minimum clearance of 3 ft.-6 inches is required to open the control panel door.

Important: *In all cases, local codes will take precedence over these recommendations.*

Ventilation

Provisions must be made to remove heat generated by unit operation from the equipment room. Ventilation must be adequate to maintain an ambient temperature lower than 125°F.

Drainage

Locate the unit near a large capacity drain for drain-down during shutdown or repair.

Handling

CICD units are shipped stretch-wrapped and bolted to a shipping skid unless special packaging is arranged.

The skidded unit can be moved by using a fork truck of suitable capacity. See Dimensions and Weights chapter for unit weights.

When moving the unit, the lifting forks must be positioned under the shipping skid as wide as possible. Lift the unit and move it to the desired location.

Once the unit is at the installation location, remove the stretch wrap. Inspect the unit for damage and report if damage is found.

Optional “ship loose” items may be inside the control box, attached to the skid or shipped separately depending on options selected.

Figure 12. CICD rigging, fork lift pockets

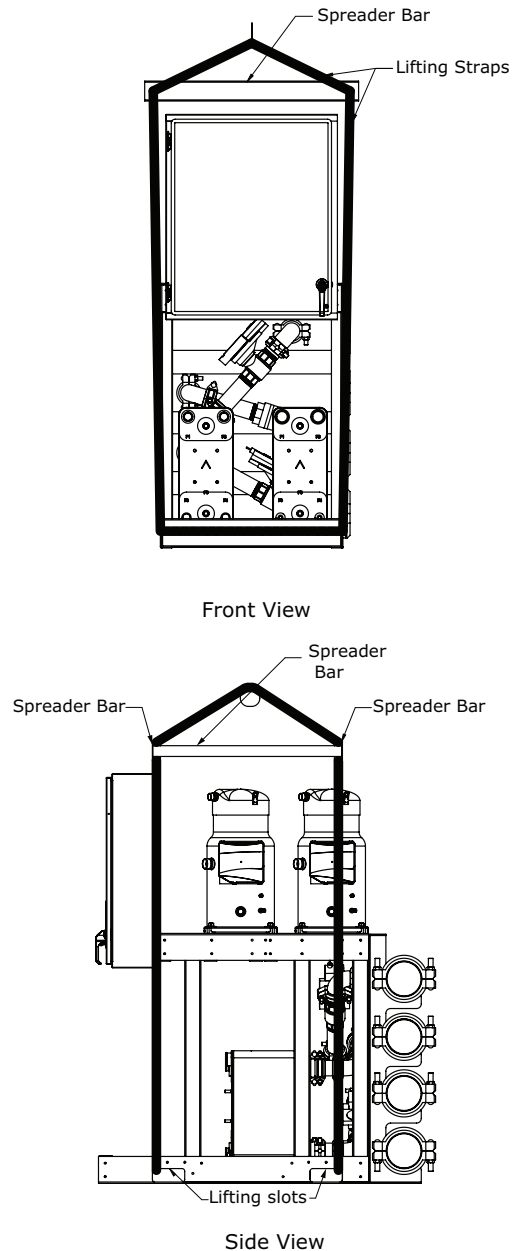

Forklifting Procedure

Important: *Step 1 through Step 4 must be followed to lift unit using a forklift.*

Steps to be taken when forklift is used:

1. Remove the stretch wrap from the unit as described previously, leaving the unit mounted to the skid.
2. Remove the bolts that secure the unit to the shipping skid.
3. Using a forklift, raise the unit enough to slightly clear the skid, making sure the unit is level when lifting.
4. If the unit is level, lift the unit off of the skid and place in the installation location.

Rigging Procedure

⚠ WARNING

Heavy Objects!

Failure to follow instructions below or properly lift unit could result in unit dropping and possibly crushing operator/technician which could result in death or serious injury, and equipment or property-only damage. Ensure that all the lifting equipment used is properly rated for the weight of the unit being lifted. Each of the cables (chains or slings), hooks, and shackles used to lift the unit must be capable of supporting the entire weight of the unit. Lifting cables (chains or slings) may not be of the same length. Adjust as necessary for even unit lift.

⚠ WARNING

Improper Unit Lift!

Failure to properly lift unit could result in unit dropping and possibly crushing operator/technician which could result in death or serious injury, and equipment or property-only damage. Test lift unit approximately 24 inches to verify proper center of gravity lift point. To avoid dropping of unit, reposition lifting point if unit is not level.

Note: *Do not lift unit from above unless spreader bars are used.*

Each module should be lifted using lift straps threaded through the steel base cutouts and a spreader bar.

Note: *If no, or improperly sized, spreader bar is used, damage to the unit may occur.*

NOTICE

Equipment Damage!

To prevent damage, position the spreader bar and straps so that they do not contact unit piping or control panel.

Access Restrictions

All CICD units are designed to pass through a standard 36 inch doorway. See outline drawings for other important dimensions.

Compressor Mounting

All compressors are rigidly bolted with compressor isolation mounts to the same compressor mounting frame (rails). No additional isolation or leveling is required. Inspect prior to start up to ensure bolts are present and tight, and that no shipping damage has occurred.

Direct Mounting

The unit can be installed directly on an isolated, rigid mounting surface as long as the surface is level and will

support the weight of the unit. A mounting hole is provided at each of the unit mounting locations. See "[Foundation](#)," p. 21 for more details. Provide a means of securely anchoring the unit to the mounting surface. Level the unit carefully.

Unit Leveling

Before tightening the mounting bolts, level the unit. Check unit level front-to-back (depth) by using a level, or by placing a level on the top surface of the unit frame. Unit should be level within 1/8 inch front-to-back (depth). Place the level on the unit frame and check side to side level. Adjust to within 1/8 inch of level side-to-side. Use shims as required to properly level the unit.

The serial number information is also on record at the factory.

Typical Water Piping

All building water piping must be flushed prior to making final connections to the chiller. To reduce heat loss and prevent condensation, insulation should be applied. Expansion tanks are also usually required so that chilled water volume changes can be accommodated.

Avoidance of Short Water Loops

Adequate water volume is an important system design parameter because it provides for stable chilled water temperature control and helps limit unacceptable short cycling of chiller compressors.

The chiller's temperature control sensor is located in the supply (outlet) water connection or pipe. This location allows the building to act as a buffer to slow the rate of change of the system water temperature. If there is not sufficient water volume in the system to provide an adequate buffer, temperature control can suffer, resulting in erratic system operation and excessive compressor cycling.

Typically, a three-minute water loop circulation time is sufficient to prevent short water loop issues. Therefore, as a guideline, ensure the volume of water in the chilled water loop is greater than or equal to three times the evaporator flow rate. For



Installation Mechanical

systems with a rapidly changing load profile the volume should be increased.

If the installed system volume does not meet the above recommendations, the following items should be given careful consideration to increase the volume of water in the system and, therefore, reduce the rate of change of the return water temperature.

- A volume buffer tank located in the return water piping.
- Larger system supply and return header piping (which also reduces system pressure drop and pump energy use).

Minimum Water Volume for a Process Application

If a chiller is attached to an on/off load such as a process load, it may be difficult for the controller to respond quickly enough to the very rapid change in return solution temperature if the system has only the minimum water volume recommended. Such systems may cause chiller low temperature safety trips or in the extreme case evaporator freezing. In this case, it may be necessary to add or increase the size of the mixing tank in the return line.

Unit Piping

See “Piping System Flushing Procedure,” p. 55 for information on piping system flushing procedure, and water treatment requirements.

Exchanger Water Pressures

NOTICE

Vessel Damage!

To prevent pressure vessel damage, do not exceed unit nameplate water-side pressures.

If field installed gauges are used, provide shutoff valves in the line(s) to the gauge(s) to isolate the gauges when not in use.

Flow Sensing Devices

NOTICE

Unexpected Chiller Start!

Failure to follow instructions could cause the chiller to start unexpectedly which could result in equipment or property damage. An external source (EMS, time clock or any other means) should not be allowed to bring on a pump that would trigger the flow switch to start the chiller. The flow switch is meant to act as a safety switch and not a start/stop mechanism.

Chilled water flow switch, or other factory approved flow proving device is mandatory; field installation by contractor is required. Flow switch is to be installed and maintained per manufacturer’s recommendations and interconnected to the control panel as described on the wiring diagram. To provide

additional chiller protection, install and wire the flow switch in series with chilled water pump interlock for the chilled water circuits. See “Required Chilled Water Flow Switch,” p. 32. Specific connection and schematic wiring diagrams ship with the unit inside the control box and in this IOM notebook.

Water Piping Recommendations

All water piping must be cleaned and flushed according to “Piping System Flushing Procedure,” p. 55 prior to circulating any water through unit.

Make sure water piping connections to the evaporator and condenser are isolated, and confirm that all piping to unit is supported independently to prevent any load being transferred to the unit. Use unions, flanges or grooved lock type fittings to facilitate service procedures. Use a pipe sealant such as Teflon® tape on all threaded water connections. Use vibration eliminators to prevent transmitting vibrations through the water lines. Construct and install piping in accordance with all local, state and national codes.

Supply and insulate the chilled water piping as required, to prevent sweating and minimize heat gain under normal operating conditions. Chilled water piping must rise above the chiller to ensure the evaporator is full of water and void of air at all times. Install thermometers in the lines to monitor evaporator entering and leaving water temperatures.

CICD chillers have manual balancing ball-valves in the entering water lines. They may be used to establish a balanced water flow. Both the entering and leaving water lines have valves that can be used to shutoff/isolate the evaporator and condenser for service.

NOTICE

Equipment Damage!

To prevent equipment damage, you MUST follow instructions below:

- Bypass unit when using a flushing agent.
- Chilled water piping must rise above the chiller to ensure the evaporator is full of water and void of air at all times.
- Do not over tighten connections.

Water Flow Rates

Establish balanced water flow through both the evaporator and condenser. Flow rates should fall between the minimum and maximum values given in General Data Table 1, p. 7. Flow rates above or below these values can cause equipment damage or improper unit operation. The evaporator and condenser water pressure drop can be read manually using the factory-installed condenser inlet and outlet pressure gauge service ports. Readings should approximate those shown by the pressure drop charts for the individual chillers (Figure 13, p. 25 and Figure 15, p. 26).

Note: Pressure drop is an approximation and is to be used as a tool to estimate flow rate and as an aid to waterside system piping design. If an accurate measurement of

flow rate is required, an accurate flow meter must be installed in the system.

Chilled Water System Volume

Minimum system volume requirements are indicated in [Figure 4, p. 25](#). Special applications may deviate from these numbers as directed by Trane engineering. Operation below these volumes will cause unacceptable system control problems and the potential for evaporator failure.

Table 4. Minimum required system volumes

Unit Size (tons)	Volume (gal)
20	144
30	216
45	324
55	396
65	468
75	540
85	612

Pressure Drop Curves

Figure 13. Evaporator pressure drop

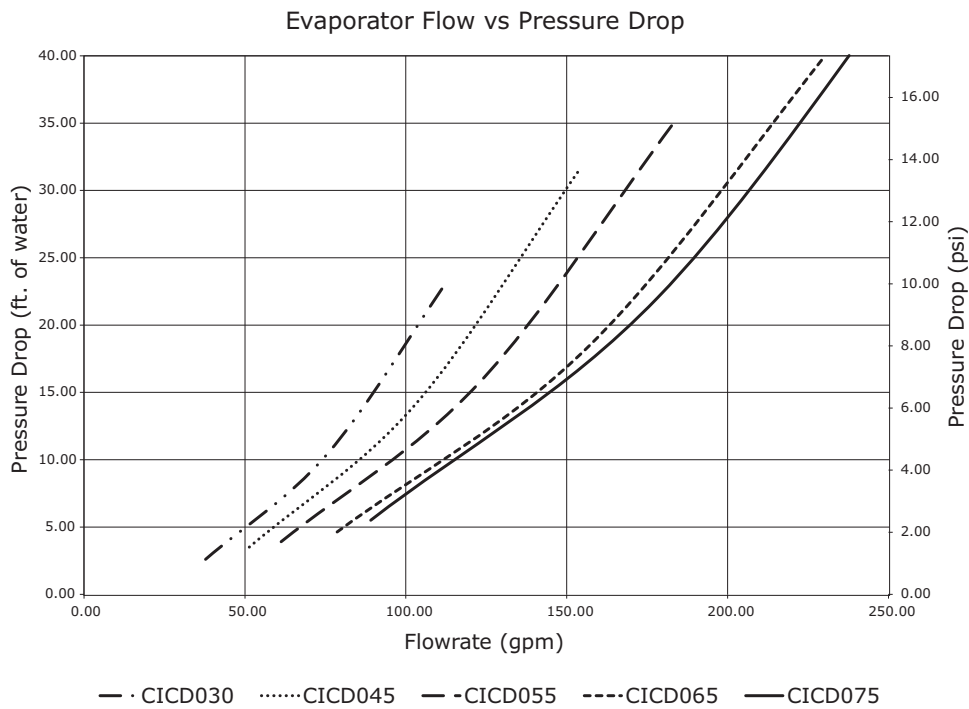
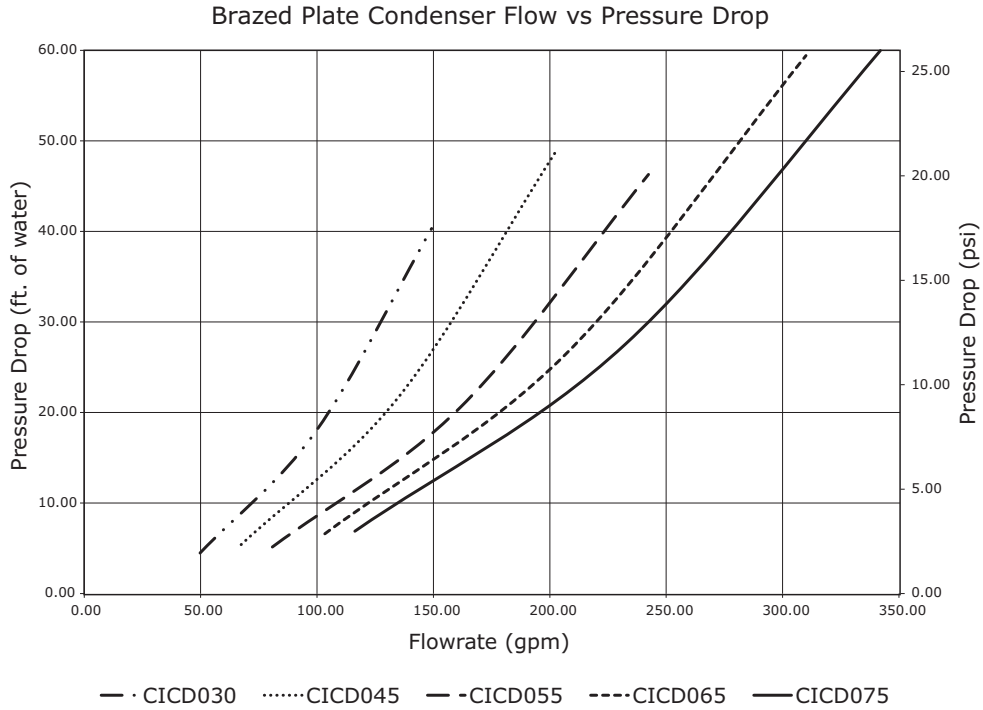
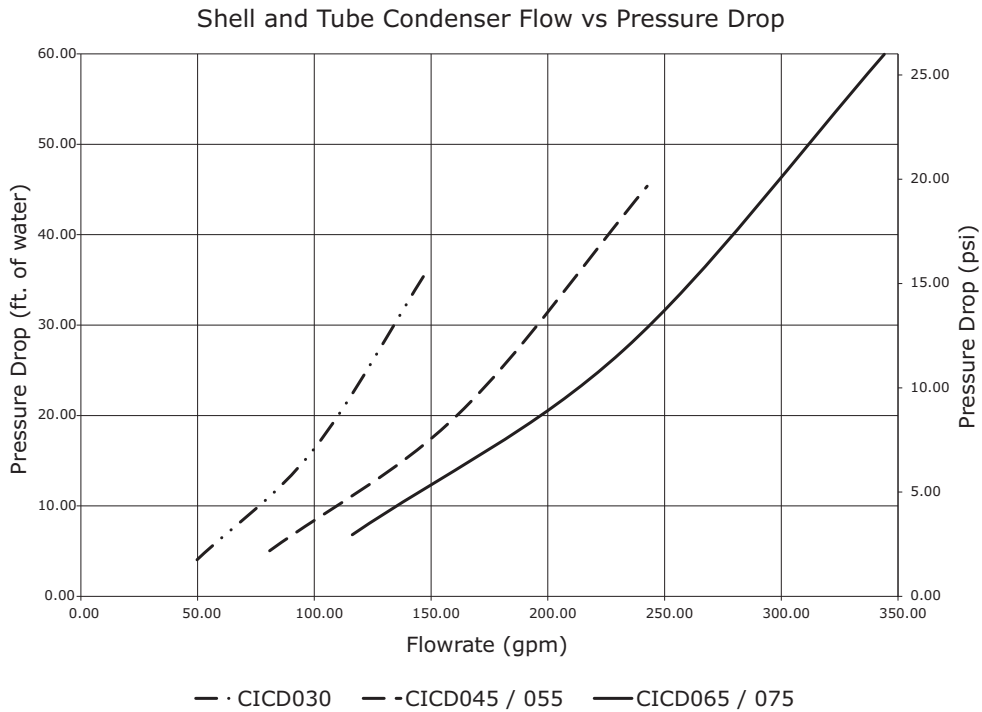

Figure 14. Condenser pressure drop

Figure 15. Shell and tube condenser pressure drop

Water Treatment

NOTICE

Proper Water Treatment!

The use of untreated or improperly treated water could result in scaling, erosion, corrosion, algae or slime. It is recommended that the services of a qualified water treatment specialist be engaged to determine what water treatment, if any, is required. Trane assumes no responsibility for equipment failures which result from untreated or improperly treated water, or saline or brackish water.

Using untreated or improperly treated water in these units may result in inefficient operation and possible heat exchanger damage. Consult a qualified water treatment specialist to determine if treatment is needed. See [“Appendix B,” p. 55](#) for water treatment requirements.

Evaporator and Water Piping

NOTICE

Water Born Debris!

To prevent evaporator or condenser damage, pipe strainers must be installed in the water supplies to protect components from waterborne debris. Trane is not responsible for equipment-only-damage caused by water born debris. Failure to install the shipped-loose supplied Y-strainers or screens will void the warranty on the brazed plate evaporator and condenser.

CICD chillers are equipped with brazed plate heat exchangers made of stamped stainless steel plates, furnace brazed together with copper based joints. Because of the small complex geometry of the flow passages, it is imperative customers take all precautions to ensure these evaporators are not fouled by large particles or mineral deposits. Chillers must have a factory provided, or field provided, 20-mesh evaporator inlet wye strainer that must be field installed. The screen may be removed for cleaning. Operation of chiller without screen in place will void warranty. Chemical treatment of the chilled water loop is required and must be performed by a qualified water treatment specialist.

Chilled water inlets and outlets are grooved-type with the locations provided in Dimension and Weights chapter. Under full-load standard AHRI conditions, the chilled water temperature change should be approximately 10°F, producing a flow rate in the range of 2.4 gpm/ton. Minimum outlet water is 42°F, with standard evaporator and without freeze inhibitor. Minimum outlet water temperature is 40° F with high capacity evaporator and without freeze inhibitor.

Chilled water piping must be in accordance with all local, state and national codes.

Figure 16. Chilled water piping

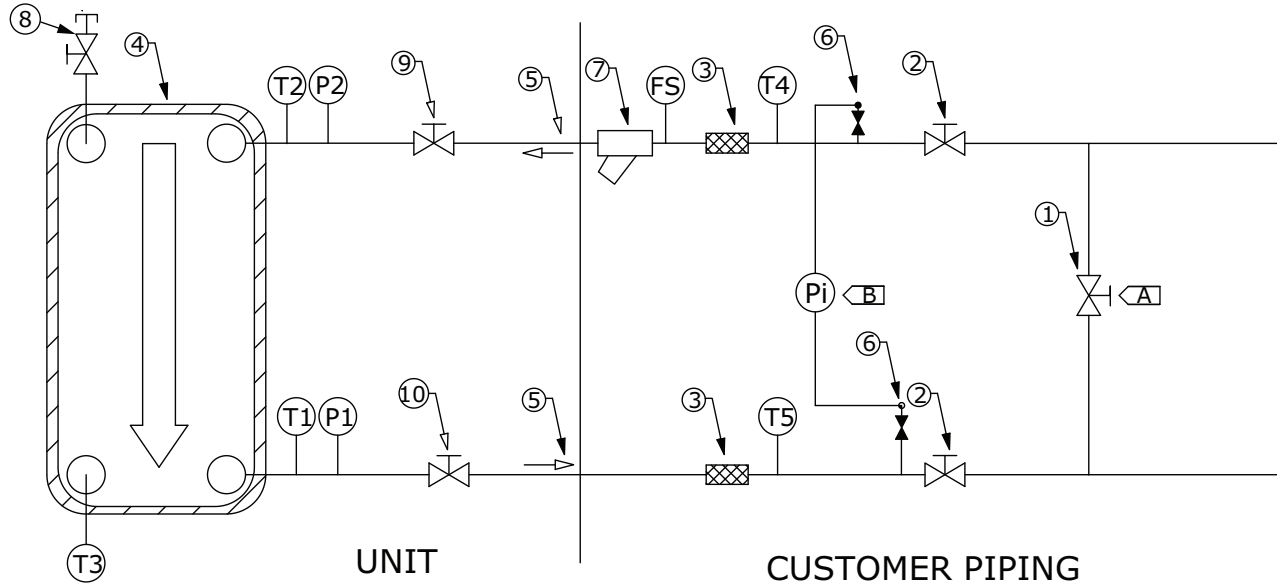

Table 5. Chilled water piping components

Item	Description	Item	Description
1	Bypass Valve	A	Isolator Unit for initial water loop cleaning
2	Isolation Valves	B ^(a)	Arrangement for Measuring Differential Pressure
3	Vibration Eliminators	FS ^(b)	Water Flow Switch
4	Evaporator Heat Exchanger	Pi	Pressure Gauge
5	Inlet & Outlet Chilled Water Lines	T1	Evaporator Outlet Temperature Sensor
6	Valves for Pressure Measurement	T2	Evaporator Inlet Temperature Sensor
7 ^(c)	Strainer with 20 Mesh Screen	T3	Evaporator Core Temperature Sensor
8	Evaporator Manual Air Vent Valve w/ Plug	T4	Chiller Inlet Temperature Gauge
9	Evaporator Manual Ball Valve	T5	Chiller Outlet Temperature Gauge
10	Evaporator Manual Ball Valve (Motorized On/Off Valve, optional)	P1	Evaporator Outlet Pressure Sensor
		P2	Evaporator Inlet Pressure Sensor

(a) Must account for water head difference when calculating total unit pressure differential.

(b) Chilled water flow-proving device is required.

(c) Strainer is factory supplied and field installed.

Condenser Piping

NOTICE

Waterborne Debris!

To prevent condenser damage, pipe strainers must be installed in the water supplies to protect components from waterborne debris. Trane is not responsible for equipment-only-damage caused by water born debris. Failure to install the shipped-loose supplied Y-strainers or screens will void the warranty on the brazed plate evaporator and condenser.

Condenser piping components and layout vary depending on the water source and connection locations, however a means of maintaining stable discharge pressure through full-, part-load, and transient conditions is required. Saturated discharge temperature must be maintained between 80°F and 145°F. Trane offers an optional factory installed water regulating valve that is controlled by unit controller. The optional water regulating valve maintains condensing pressure and temperature by throttling water flow leaving the condenser in response to compressor discharge pressure. Field supplied water regulating valves must be adjusted for proper operation during start-up. Under full load “standard AHRI conditions” the water temperature rise should be 10° F, producing a flow rate in the range of 3 gpm per ton. Minimum inlet condenser water

temperature is 65°F. Condenser piping must be in accordance with all local and national codes. Condenser piping components generally function identically to those in the evaporator piping system. In addition, cooling tower systems may include a manual or automatic bypass valve that can alter water flow rate to maintain condensing pressure. Well (city) water condensing systems should include a pressure reducing valve and water regulating valve. A pressure reducing valve should be installed to reduce water pressure entering the condenser. This is required only if water pressure exceeds nameplate maximums. This is also necessary to prevent damage to the disc and seat of the water regulating valve that can be caused by excessive pressure drop through the valve.



Installation Electrical

⚠ WARNING

Proper Field Wiring and Grounding Required!

Failure to follow code could result in death or serious injury. All field wiring **MUST** be performed by qualified personnel. Improperly installed and grounded field wiring poses **FIRE** and **ELECTROCUTION** hazards. To avoid these hazards, you **MUST** follow requirements for field wiring installation and grounding as described in **NEC** and your local/state electrical codes.

General Recommendations

⚠ WARNING

Hazardous Service Procedures!

Failure to follow all precautions in this manual and on the tags, stickers, and labels could result in death or serious injury. Technicians, in order to protect themselves from potential electrical, mechanical, and chemical hazards, **MUST** follow precautions in this manual and on the tags, stickers, and labels, as well as the following instructions: **Unless specified otherwise, disconnect all electrical power including remote disconnect and discharge all energy storing devices such as capacitors before servicing. Follow proper lockout/tagout procedures to ensure the power can not be inadvertently energized. When necessary to work with live electrical components, have a qualified licensed electrician or other individual who has been trained in handling live electrical components perform these tasks.**

NOTICE

Use Copper Conductors Only!

Failure to use copper conductors could result in equipment damage as unit terminals are not designed to accept other types of conductors.

The wiring procedures, as described in this portion of the manual, must be accomplished to obtain proper operation of the unit.

All wiring must comply with National Electrical Code (NEC) and state and local requirements. Outside the United States, the national and/or local electrical requirements of other countries shall apply. The installer must provide properly sized system interconnecting and power supply wiring with appropriate fused disconnect switches. Type and locations of disconnects must comply with all applicable codes.

Minimum circuit ampacity, recommended fuse sizes and other unit electrical data are provided "[Electrical Data](#)," p. 10 and on the unit nameplate.

Checking the Power Supply

Electrical power to the unit must meet stringent requirements for the unit to operate properly. Total voltage supply and voltage imbalance between phases should be within the tolerances listed in this manual.

Total Supply Voltage

⚠ WARNING

Live Electrical Components!

Failure to follow all electrical safety precautions when exposed to live electrical components could result in death or serious injury. When necessary to work with live electrical components, have a qualified licensed electrician or other individual who has been properly trained in handling live electrical components perform these tasks.

Measure each leg of the supply voltage at the line voltage disconnect switches. For units with a nameplate voltage of 208/230 volt, the readings must fall within the range of 180-253 volts. For units with a nameplate voltage of 460 volts, the readings must fall within the range of 414-506 volts. If voltage on any leg does not fall within tolerance, notify the power company and request correction of this situation before connecting to or operating the unit. Inadequate voltage to the unit will shorten the life of relay contacts and compressor motors.

Voltage Imbalance Between Phases

Excessive voltage imbalance between phases in a three-phase system will cause motors to overheat and eventually fail. Maximum allowable imbalance is 2 percent. Voltage imbalance is defined as 100 times the maximum deviation of the three voltages (three phases) subtracted from the average (without regard to sign), divided by the average voltage.

EXAMPLE:

If the three voltages measured at the line voltage fused disconnect are 221 volts, 230 volts and 227 volts, the average would be:

$$\frac{221 + 230 + 227}{3} = 226 \text{ volts}$$

The percentage of imbalance is then:

$$\frac{100 (226 - 221)}{226} = 2.2\%$$

In the preceding example, 221 is used because it is the farthest from the average. The 2.2 percent imbalance that exists exceeds maximum allowable imbalance by 0.2 percent. This much imbalance between phases can equal as much as 20 percent current imbalance with a resulting increase in winding temperature that will decrease compressor motor life.

Equipment Grounding

NOTICE

Use Copper Conductors Only!

Failure to use copper conductors could result in equipment damage as unit terminals are not designed to accept other types of conductors.

Provide proper grounding at the connection point provided in the unit control panel.

Unit Power Wiring

⚠ WARNING

Hazardous Voltage!

Failure to disconnect power before servicing could result in death or serious injury. Disconnect all electric power, including remote disconnects before servicing. Follow proper lockout/tagout procedures to ensure the power can not be inadvertently energized.

The installing contractor must connect appropriate power wiring (with fused disconnects) to the unit-mounted, non-fused disconnect in the power section of the unit control panel. Electrical schematics and component location drawings are also mounted on the inside of the control panel door.

The unit power fused disconnect switch should be located in the general area of the unit, to comply with NEC or local codes. Some codes require line-of-sight disconnect locations. The unit mounted non-fused disconnect can be used as an emergency shutdown device.

Scroll Compressor Electrical Phasing

NOTICE

Compressor Damage!

Operating compressors in reverse rotation will cause damage or failure of the compressor.

It is critical that proper rotation of the scroll compressors be established before the machine is started. Proper motor rotation requires confirmation of the electrical phase sequence of the power supply. The motor is internally connected for clockwise rotation with the inlet power supply phased "ABC" or "L1, L2, L3".

The order in which the three voltage waveforms of a three-phase system succeed one another is called phase sequence or phase rotation. When rotation is clockwise, phase sequence is usually called "ABC" and when counterclockwise, "CBA".

This direction may be reversed by interchanging any two of the line wires. The possibility of interchanging the wiring makes a phase sequence indicator necessary to quickly determine the proper phase rotation.

Setting the Proper Electrical Phase Sequence

Proper compressor motor electrical phasing can be quickly determined and, if necessary, corrected before starting the unit. Use a quality instrument, such as an Associated Research Model 45 Phase Sequence indicator or equivalent and follow this procedure:

1. Verify that all operating controls for the unit are in the "Off" position.
2. Turn power to CICD unit "Off" using supply power disconnect to the unit. Verify that power to CICD unit is "Off" and that there is no voltage on "Line" or entering side of the CICD panel mounted unit disconnect.
3. Connect the phase sequence indicator leads to the "Load" or leaving side of the CICD unit panel mounted disconnect as follows:

Phase Sequence Lead	Terminal ID
Black (Phase A)	L1
Red (Phase B)	L2
Yellow (Phase C)	L3

4. Turn power to CICD unit "On" using the supply power disconnect to the unit
5. Read the phase sequence displayed on the indicator. The "ABC" LED on the face of the phase indicator will glow if phase sequence is ABC.
6. If the "CBA" indicator glows instead, turn power to CICD unit "Off" using the supply power disconnect to the unit, then verify that the power to the CICD unit is "Off" and that there is no voltage on the "Line" side of the CICD panel mounted unit disconnect. Reverse two wires on the "Line" or entering side of the CICD panel mounted disconnect switch. Turn power to CICD unit "On" and recheck phase sequence ([Step 5](#) above).
7. If phase sequence is correct, turn power to CICD unit "Off" using the supply power disconnect to the unit. Verify that power to the CICD unit is "Off" and that there is no voltage on "Line" or entering side of the CICD panel mounted unit disconnect. Remove the phase indicator and restore power to the CICD unit.



Control Power Supply

A fused, panel-mounted control power transformer is standard. Replacement fuse information is listed on the “Fuse Schedule” decal located adjacent to the transformer inside the control box.

External Contacts and Peripherals

The following peripheral control features and program logic come standard on all CICD compact chillers. Designated terminals on the field connection terminal strip in the control panel are provided for field connection of each. Consult the field wiring diagram and wiring schematic diagram provided in this manual for the connection points. The wiring schematic diagram is also attached to the inside of the control panel door.

Required Chilled Water Flow Switch

⚠ WARNING

Unexpected Chiller Start!

Failure to follow instructions could cause the chiller to start unexpectedly which could result in equipment or property damage. An external source (EMS, time clock or any other means) should not be allowed to bring on a pump that would trigger the flow switch to start the chiller. The flow switch is meant to act as a safety switch and not a start/stop mechanism.

The CICD controller has a required input that accepts a contact closure from a proof-of-flow device such as a flow switch or other factory approved flow proving device. When this input does not prove flow within a fixed time relative to transition from enabled to run modes of the chiller, or if the flow is lost while the chiller is in the running mode of operation, the chiller will be prohibited from running. The installer must provide and install this flow proving device. Failure to provide this flow proving device voids unit warranty.

Condenser Water Loss of Flow Protection

The CICD controller logic will sense a loss of flow through the condenser. No condenser water flow switches are necessary with the standard standalone CICD controller configuration.

Required Pump Control

CICD units have one dry contact relay which is required to start the chilled water pump. These chillers also have one dry contact relay to start a condenser pump. These features are standard but only the chilled water pump control is required.

Remote Off/Auto

The CICD controller has an input that accepts a contact closure from a remote device such as a toggle switch that can enable or disable the chiller to run. It would be wired in series with the Off/Auto switch located on the control panel door. This feature is standard but not required.

Remote Alarm

CICD units have one dry contact relay to indicate with a remote light or bell or other device that at least one compressor in the unit has been locked out for whatever reason and needs attention. This feature is standard but not required.



Controls Interface

Unit Controller — General

The CICD controller is a rugged microprocessor-based controller designed for the hostile environment of the HVAC/R industry. It is designed to be the primary manager of the CICD product.

The controller provides flexibility with setpoints and control options that can be selected prior to commissioning a system or when the unit is live and functioning. Unit display presents pressure, temperature and alarm information with history in a clear and simple language format, informing the user of the chiller status. See wiring diagram in the wiring section of this manual (“Wiring,” p. 42) and attached to the inside of the control panel door.

A password is required to access chiller setpoints. Use password code 2112 to access many of these features. A factory code may be required to allow access to critical areas, and can only be entered by a factory representative.

An RS-485 port is provided for communication with other manufacturers’ systems.

Additionally, a built-in RS-485 to RS-232 converter allows communication over the RS-485 network via the RS-232 port.

Other features include the integration of BACnet IP® and MODBUS® into the unit controller. Optional communication cards are available for communication via LONWORKS®, Johnson N2 and BACnet MS/TP®. This should be ordered with the chiller if required. An ethernet connection is also provided on each unit. While field changes can be made, please ensure that the unit is ordered set up for required communications to ensure that factory testing includes end user configuration.

A complete software support package is available for your PC allowing for system configuration, dynamic on-line display screens, remote communication, graphing and more. Downloads for the MCS-Connect software are available at www.mcscontrols.com at no charge. See “[Downloading and Installing Unit Controller \(MCS-Connect\) Software](#),” p. 33 for download instructions. All information needed to run the unit is available from the unit display; however, a laptop computer is invaluable for ease of use of diagnosing or changing the unit setpoints.

Note: *Not all setpoints can be changed with MCS-Connect; some require a configuration change.*

A serial cable is included in each shipment for the convenience of the field technician. If you do not have a laptop with a serial port, you will require a converter such as a Black Box item number #IC199A-R3 serial-to-USB adaptor.

The CICD standard configuration allows for the unit to start at the lowest stage possible, and then add compressors as needed to meet demand.

Important: *All configuration changes need to be done by factory representatives to ensure proper operation of the unit within design parameters. See CG-SVX030*-EN controller manual for sequence of operation and additional details.*

Unit Controller Software Installation and Setup

Downloading and Installing Unit Controller (MCS-Connect) Software

Go to www.mcscontrols.com.

Go to the software page and select MCS-CONNECT. Select SAVE. After downloading, open and select RUN. Follow prompts and software will be installed on your computer.

If your computer does not have a serial port, you will need to purchase a USB to Serial adapter. (Computer stores should have this.) Install the software for the adapter. If your computer has a serial port, you will not need an adapter.

Start the MCS-CONNECT software. Select SETUP>COMMUNICATIONS and then change LOCAL COM PORT to match your computer. Select SAVE and then OK.

Connecting to the Chiller

Connect the supplied NULL MODEM cable between your USB adapter or serial port to the chiller. A standard serial cable will not work.

Connection directly through the 100 MBPS Ethernet port on the CICD unit controller or array controller to a PC requires a crossover Ethernet cable. If all controllers in the array are connected to an Ethernet switch, then an Ethernet patch (straight) cable will be used to connect the PC to the Ethernet switch.

Start the MCS-CONNECT software and select LOCAL SERIAL. The site info page will appear. The software should scan and find the chiller. (If you see a Failed to open comm port error, or it scans and does not find the chiller, your comm port settings are not correct.) Click the tab next to the “Site Info” tab. The screen shows real time data.

Setpoint Changes

Click the VIEW ONLY button. Enter the password code 2112. Select OK. Button should say SERVICE. Go to setpoints and double-click on a value. Change and select OK.

Viewing and Troubleshooting ALARMS

The unit controller will record and store 120 seconds of sensor input data prior to and up to any LOCKOUT ALARM. Select the ALARM tab, then INFO next to the alarm you want to analyze. This will pop up a screen that shows operating conditions just prior to the trip allowing the user to determine if the fault was caused by a sudden or gradual change. For instance, a sudden increase in discharge pressure might suggest a condenser pump or fan failure etc. (This data can also be viewed from the chiller LCD screen. Select LOCKOUT ALARMS.)



Downloading and Viewing Graphs

The unit controller continuously records and stores sensor input and relay/analog output data. This data is collected in 10-second (default) intervals. The controller stores 1008 packets of data replacing the oldest with the newest. With the time interval set at 10 seconds, graph data can be downloaded with a time span of 168 minutes. The time interval is adjustable.

In the MCS-CONNECT software, select GRAPH. Data will be downloaded and then a graph setup page will appear. Select the input and output data to be viewed. Type in Y-axis parameters and select OK. Use the scroll bar at the bottom of the graph to view. Return to the setup page at any time to change selections. The graph may be saved. The saved graph will be located in a folder called GRAPH inside another folder called MCS on the C: drive.

To change the default 10-second interval, make changes and select SAVE and then OK on the setup page. The controller will now record data at this new interval.

To view a saved graph, select LOAD A GRAPH FILE. These files can be e-mailed for analysis if needed.

Updating Chiller Software and Configuration Files

CICD chillers are programmed, set up, and tested prior to shipment. Sometimes after a unit arrives at the jobsite, the customer may want to enable an option such as 0–5 Vdc target reset, etc. These options require a configuration change. The configuration file must be downloaded and electronically sent to the factory for the changes to be made or the factory may modify a default configuration file and electronically send the modified default configuration to the customer. Modifying a configuration file will save any setpoint changes that have been made on site. Otherwise, the controller will be set back to default factory settings.

To e-mail a copy of the chiller's configuration file, in the MCS-CONNECT software, establish communication with the chiller and select RECEIVE CFG.

Name it "Unit (*serial number*)" and e-mail to engineering@nappstech.com.

To load a configuration file, turn off circuit enable switches and select TRANSMIT CFG. Locate the new file and press OPEN. The file will be uploaded to the controller. The controller will reboot itself.

Routine software (HEX FILE) updates are NOT necessary. However, if a software update is necessary to resolve an operating issue, a hex file in a zipped folder will be provided. Save the zipped folder to the computer's desktop. Right click folder and select EXTRACT ALL. This will create another folder by the same name on the computer's desktop. Inside this folder will be the hex file. It should be about 2300 KB. In the MCS-CONNECT software, select TRANSMIT SW. Locate the extracted hex file and select Transmit. Watch the chiller LCD screen. After the file is uploaded, the CICD unit controller will verify that it's a valid file and then erase the flash memory. Next, it will write the new hex to memory. When completed, the controller will reboot itself. This process may take 15 or 20

minutes. After the reboot is completed, close and restart the MCS-CONNECT software to reestablish communication with the chiller.



Unit Start-Up Procedures

Prior to calling for start-up services or commissioning, *CICD Compact Chiller Installation Completion Check List and Request for Trane Service, CG-ADF003*-EN*, must be completed and submitted. Once that has been completed and submitted, *CICD Compact Chiller Start-up Check List, CG-ADF004*-EN*, must be followed and submitted. A hard copy of each document is sent with the chiller in the IOM notebook.

Start-up and commissioning must be performed by a factory authorized Trane service technician.

Pre-Start

Complete each step in the "Pre-Start Up Procedures" included in the *CICD Individual Chiller Start-up Check List* and check off each step as completed.

⚠ WARNING

Hazardous Voltage!

Failure to disconnect power before servicing could result in death or serious injury. Disconnect all electric power, including remote disconnects before servicing. Follow proper lockout/tagout procedures to ensure the power can not be inadvertently energized.

NOTICE

Equipment Damage!

- To prevent overheating at connections and under-voltage conditions at the compressor motor, check tightness of all connections in the compressor power circuit.
- To prevent compressor damage, do not operate the unit with discharge or liquid line service valves closed.
- The use of untreated or improperly treated water in a Chiller may result in scaling, erosion, corrosion, algae or slime. It is recommended that the services of a qualified water treatment specialist be engaged to determine what water treatment, if any, is required. Trane assumes no responsibility for equipment failures which result from untreated or improperly treated water, or saline or brackish water.
- To prevent evaporator or condenser damage, pipe strainers must be installed in the water supplies to protect components from water born debris. Trane is not responsible for equipment damage caused by water born debris.

Sequence of Operation

Figure 17. Unit power-up

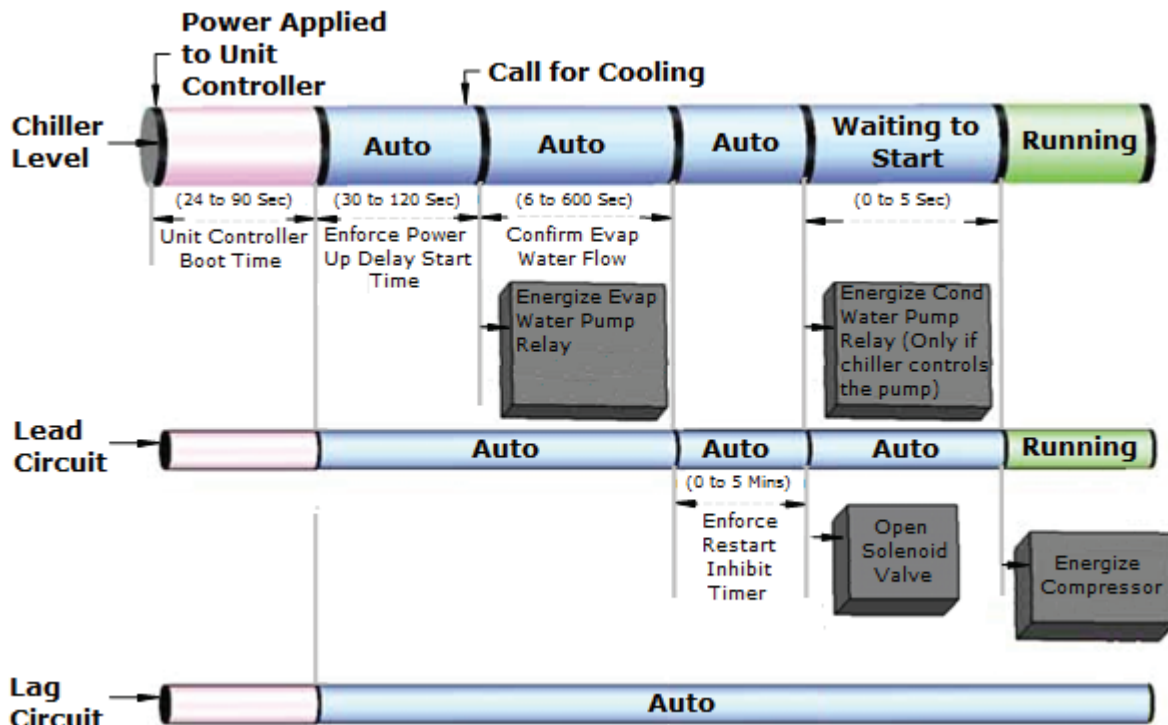



Checking Operating Conditions

NOTICE

Evaporator/Condenser Damage!

Water (fluid) flow must be established in evaporator and condenser before adding refrigerant, removing refrigerant, or pulling vacuum to protect heat exchangers from freezing.

NOTICE

Compressor Damage!

Do not allow liquid refrigerant to enter the suction line as excessive liquid accumulation in the liquid lines could result in compressor damage.

To prevent compressor damage and ensure full cooling capacity, only use refrigerant specified on unit nameplate.

- If operating conditions indicate an overcharge, slowly (to minimize oil loss) remove refrigerant at the liquid line Schrader fitting. Do not discharge refrigerant into the atmosphere.
- Once proper unit operation is confirmed, inspect for debris, misplaced tools, etc. Secure control panel doors in place.

Once the unit has been operating for about 10 minutes and the system has stabilized, check operating conditions and complete the checkout procedures that follow.

- Recheck evaporator water and condenser water flows and pressure drops. These readings should be stable at proper levels.
- Check suction pressure and discharge pressure.
 - **Discharge pressure:** Take at Schrader fitting provided on the discharge line. Normal discharge pressures are:
 - 90°F to 120°F Condenser LWT: 275 to 430 psig
 - 120°F to 140°F Condenser LWT: 430 to 560 psig
 - **Suction pressure:** Take at Schrader fitting provided on the suction line. Normal suction pressures are:
 - 42°F to 60°F LWT: 104 to 155 psig
 - 15°F to 39°F LWT: 60 to 103 psig
- Check compressor oil level. At full load, oil level should be visible in the oil level sight glass on the compressor. If it is not, add or remove oil as required.
- Check the liquid line sight glass. Refrigerant flow past the sight glass should be clear. Bubbles in the liquid line indicate either low refrigerant charge or excessive pressure drop in the liquid line. Such a restriction can often be identified by a noticeable temperature differential on either side of the restricted area. Frost often forms on the outside of the liquid line at this point also.

Important: *The system may not be properly charged although the sight glass is clear. Also consider*

superheat, sub-cooling and operating pressure.

- Once oil level, amp draw and operating pressures have stabilized, measure system suction superheat.
- Measure system liquid line sub-cooling.
- If operating pressure, sight glass, superheat and sub-cooling readings indicate refrigerant shortage, charge refrigerant into each circuit. Refrigerant shortage is indicated if operating pressures are low and sub-cooling is also low.

Important: *If suction and discharge pressures are low but subcooling is normal, no refrigerant shortage exists. Adding refrigerant, will result in overcharging.*

- Add refrigerant with the unit running by metering liquid refrigerant through the Schrader valve between the expansion valve and the evaporator refrigerant inlet until operating conditions are normal.

System Superheat

Normal superheat is 10°F to 16°F at full load. Expansion valve superheat is factory set. Contact factory before making any adjustment.

System Subcooling

Normal subcooling is 5°F to 10°F at full load where saturated discharge pressure and liquid line temperature are measured at chiller liquid line.

Shut Down

Normal Unit Shutdown

Figure 18. Normal unit shutdown

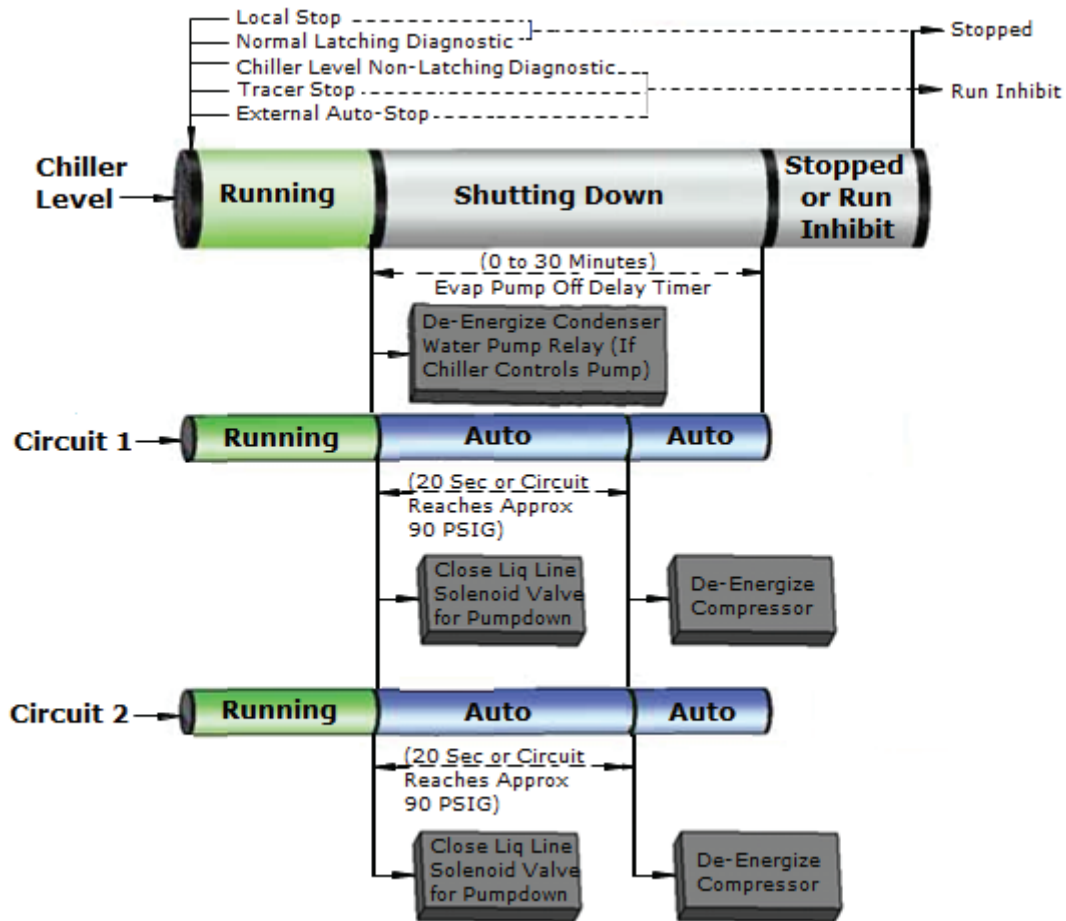

Extended Shutdown Procedure

If the system is taken out of operation for long periods of time, use this procedure to prepare the system for shutdown.

1. Test condenser and high side piping for refrigerant leakage.
2. Open electrical disconnect switches for evaporator water pump. Lock the disconnect in an open position.
3. Open the unit main electrical disconnect and unit-mounted disconnect and lock in open position.



Unit Restart

Unit Restart After Extended Shutdown

Use this procedure to prepare the system for restart after an extended shutdown.

NOTICE

Compressor Failure!

To protect compressors from premature failure the unit must be powered and crankcase heaters energized at least 24 hours BEFORE compressors are started.

NOTICE

Compressor Damage!

To prevent compressor damage, be certain that all refrigerant valves are open before starting the unit.

1. Close the unit main disconnect(s) and the unit- mounted disconnect.
2. Check compressor crankcase oil levels. Oil should be visible in the compressor oil level sight glass
3. Fill the chilled water circuit if drained during shutdown. Vent the system while filling it.
4. Close the fused disconnect switches for the water pumps.
5. Start the water pumps. With water pumps running, inspect all piping connections for leakage. Make any necessary repairs.
6. With water pumps running, adjust chilled water flow and check water pressure drop through the evaporator.
7. Check the flow switch on the evaporator outlet piping for proper operation.
8. Stop the water pumps.
9. Complete each step in CICD Individual Chiller Start-up Check List CG-ADF004*-EN.
10. Energize crankcase heaters. (Heaters must be energized a minimum of 24 hours before startup.)



Maintenance

⚠ WARNING

Hazardous Service Procedures!

Failure to follow all precautions in this manual and on the tags, stickers, and labels could result in death or serious injury.

Technicians, in order to protect themselves from potential electrical, mechanical, and chemical hazards, **MUST** follow precautions in this manual and on the tags, stickers, and labels, as well as the following instructions: Unless specified otherwise, disconnect all electrical power including remote disconnect and discharge all energy storing devices such as capacitors before servicing. Follow proper lockout/tagout procedures to ensure the power can not be inadvertently energized. When necessary to work with live electrical components, have a qualified licensed electrician or other individual who has been trained in handling live electrical components perform these tasks.

Periodic Maintenance

Perform all of the indicated maintenance procedures at the intervals scheduled. This will prolong the life of the unit and reduce the possibility of costly equipment failure. All maintenance tasks other than recording data must be performed by a qualified service technician.

Weekly Maintenance

Ensure the unit has been operating for about 10 minutes and the system has stabilized, check operating conditions and complete the checkout procedures that follow.

- Check compressor oil levels. Oil should be visible in the sight glass when the compressor is running. Operate the compressors for a minimum of three to four hours when checking oil level, and check level every 30 minutes. If oil is not at proper level after this period, have a qualified service technician add or remove oil as required.
- Check suction pressure and discharge pressure.
- Check the liquid line sight glasses.
- If operating pressures and sight glass conditions seem to indicate refrigerant shortage, measure system superheat and system sub-cooling.
- If operating conditions indicate an overcharge, slowly (to minimize oil loss) remove refrigerant at the liquid line service valve. Do not release refrigerant to the atmosphere.
- Inspect the entire system for unusual conditions. Use an operating log to record weekly operating conditions history for the unit. A complete operating log is a valuable diagnostic tool for service personnel.

Monthly Maintenance

Ensure the unit has been operating for about 10 minutes and the system has stabilized, check operating conditions and complete the checkout procedures that follow.

- Check compressor oil levels. Oil should be visible in the sight glass when the compressor is running. Operate the compressors for a minimum of three to four hours when checking the oil level, and check level every 30 minutes. If oil is not at proper level after this period, have a qualified service technician add or remove oil as required.
- Check refrigerant superheat at the compressor suction line. Superheat should be in the range of 10°F–20°F.
Note: A superheat calculated value is incorporated into the unit controller.
- Check the liquid line sight glasses.
- If operating pressures and sight glass conditions seem to indicate refrigerant shortage, measure system superheat and system sub-cooling.
- If operating conditions indicate an overcharge, slowly (to minimize oil loss) remove refrigerant at the liquid line service valve. Do not release refrigerant to the atmosphere.
- Inspect the entire system for unusual conditions. Review the weekly operating log for conditions history for the unit and take note of any unusual trends in performance. Take appropriate preventative actions if necessary.

Annually

Perform all weekly and monthly maintenance procedures.

- Have a qualified service technician check the setting and function of each control and inspect the condition of and replace compressor and control contacts if needed.
- If chiller is not piped to drain facilities, make sure drain is clear to carry away system water.
- Drain water from condenser and evaporator and associated piping systems. Inspect all piping components for leakage, damage, etc. Clean out evaporator and condenser supply strainers.
- Clean and repaint any corroded surface.

Compressor Maintenance

Compressor Oil

The R-410A scroll compressor uses POE oil as required by the manufacturer of the compressor. Refer to compressor manufacturer for exact type and amount of oil in the specific model in question.

Oil Level

While the compressor is running, the oil level may be below the sight glass but still visible through the sight glass. The oil level should NEVER be above the sight glass!

Oil Appearance

If the oil is dark and smells burnt, it was overheated because of compressor operation at extremely high condensing temperatures, a compressor mechanical failure, or occurrence of a motor burnout. If the oil is black and contains metal flakes, a mechanical failure has occurred. This symptom is often accompanied by a high amperage draw at the compressor motor.

Notes:

- *If a motor burnout is suspected, use an acid test kit to check the condition of the oil. If a burnout has occurred, test results will indicate an acid level exceeding 0.05 mg KOH/g.*
- *The use of commercially available oil additives is not recommended. Liability for any detrimental effects that the use of non-approved products may have on equipment performance or longevity must be assumed by the equipment owner, equipment service technician, or the oil additive manufacturer.*

Scroll Compressor Functional Test

Since the scroll compressor does not use discharge or suction valves, it is not necessary to perform a pump-down capability test, i.e. a test where the liquid line valve is closed and the compressor is pumped in a vacuum to see if it will pump-down and hold. In fact, this kind of test may actually damage the scroll compressor.

NOTICE

Compressor Damage!

Do not pump the scroll compressor into a vacuum. Scroll compressors can pull internal low vacuums when the suction side is closed or restricted. This, in turn, can lead to compressor failure due to internal arcing and instability in the scroll wraps.

The proper procedure for checking scroll compressor operation is outlined below:

1. Verify that the compressor is receiving supply power of the proper voltage.
2. With the compressor running, check suction pressure and discharge pressure.

Discharge pressure: Take at Schrader fitting provided on the discharge line. Normal discharge pressures are:

- 90°F to 120°F Condenser LWT: 275 to 430 psig
- 120°F to 140°F Condenser LWT: 430 to 560 psig

Suction pressure: Take at Schrader fitting provided on the suction line. Normal suction pressures are:

- 42°F to 60°F LWT: 104 to 155 psig
- 15°F to 39°F LWT: 60 to 103 psig

Compressor Operational Noises

At low ambient startup: When the compressor starts up under low ambient conditions, the initial flow rate of the compressor is low. Under these conditions, it is not unusual to hear the compressor rattle until the suction pressure climbs and the flow rate increases. These sounds are normal and do NOT affect the operation or reliability of the compressor.

Excessive Amp Draw

Excessive Amp Draw occurs either because the compressor is operating at an abnormally high condensing temperature OR because of low voltage at the compressor motor.

Motor amp draw may also be excessive if the compressor has internal mechanical damage. In this situation, vibration and discolored oil can also be observed.

Low Suctions

Continuous low suction pressures are most likely caused by low evaporator load coupled with a system anomaly such as low chilled water flow.

Note: *Operation of the chiller with saturated suction temperatures below freezing will cause damage to the evaporator. If this occurs immediately stop the machine, diagnose and correct the problem.*

Heat Exchanger Maintenance

When to Clean a Brazed Plate Heat Exchanger (BPHE)

A temperature difference, less than specified, indicates a sign of scaling because fouling of the channel plate surface decreases the heat transfer. Hence the inlet and outlet temperatures of the BPHE should be measured continuously. Pressure drops larger than specified indicate scaling since it restricts the channel passage and thus increases velocity. Make sure that readings follow water flow rate corresponding to the specification, since changes in flow rate effect temperatures and pressure drops. By removing the scale build-ups, the operating efficiencies of the equipment and heat transfer surfaces are restored. Other benefits from removing the scale are that it lowers the pressure drops, reduces the power consumption and extends the lifetime of the equipment.

How to Clean a Brazed Plate Heat Exchanger (BPHE)

CICD chiller BPHEs are cleaned quickly and easily with Cleaning in Place (CIP), a method used for the interior surfaces of closed systems, such as pipes, vessels, process equipment, and filters. A chemical fluid is circulated through the BPHE, without the need for disassembly. The chemicals dissolve or loosen deposits from process equipment and piping, giving uniform removal and lower overall operating costs. Following is a general description of the system setup, the CIP procedure, and the various cleaning fluids.

Cleaning in Place (CIP) Procedure

Start

1. Shut off relevant pumps
2. Shut off the primary side's valves
3. Shut off the secondary side's valves
4. Empty the BPHE
5. Wash it with water to remove loose contamination
6. Connect the machine via inlet/outlet at front or backside
7. Mix chemical and water according to instructions such as for Scale 132 Copper
8. Heat the solution to 120-140°F, make use of primary side heat if possible
9. Pump the solution in the BPHE using the lower opening to ventilate air. A flow rate corresponding to 1.5 times the normal flow rate is suitable. Reverse the flow direction every 30 min if possible. Monitor the pressure differential. A pressure differential equal to design criteria indicates a clean BPHE. Alternatively, monitor pH. Constant pH value for 30 minutes indicates a clean BPHE. For Scale 132 Copper pH of 3 indicates the need to renew the cleaning solution, then empty the BPHE and restart at point 5. The cleaning time varies, but is estimated to 4-8 hours.

Stop

10. Flush from the lower opening for 5 minutes before changing direction. Repeat this operation until no more dirt is flushed out
11. Empty the BPHE and the machine, handle the used solution properly
12. Flush the BPHE with water starting from the lower opening until pH 7
13. To pickle and passivate steel use 2% phosphoric acid at 50°C (120°F) for 4-6 h.
14. Flush the BPHE with water starting from the lower opening until pH 7

CIP Fluids

Bio Gen Active – Scale 132 Copper

Commercially available Scale 132 Copper removes lime scale and other carbonates as well as rust and other metal oxides without the risk of corrosion.

Organic Acids

Organic acids are less hazardous than mineral acids, which makes them a good choice for BPHE cleaning. Organic acids include formic, acetic, and citric acids, among others, and are commonly applied at concentrations between 1 and 5 volume percent.

Formic Acid

Formic acid alone is unable to remove iron oxide why it's used as a mixture with citric acid or HCl. Formic acid can be used on

stainless steels, it's relatively inexpensive and can be disposed by incineration.

Acetic Acid

Dissolves lime scale, but doesn't remove iron oxide deposits. Since it's weaker than formic acid, it is preferred where long contact times are necessary.

Citric Acid

Mild iron contamination can be removed by using a mixture of 1% each of citric acid and HNO₃. For more persistent contaminations, stronger solutions must be used.

Bases

Bases have the ability of removing oil, grease and biological deposits from the heat exchanger surface and may be applied as a complement during cleaning. They may also be added at the end of the cleaning procedure, before the last rinse with water, to neutralize any acid content left in the system. A solution of 1-2% sodium hydroxide (NaOH) or sodium bicarbonate (NaHCO₃) before the last rinse ensures that all acid is neutralized.

CIP Pumps

Important features:

- The reservoir should be made in acid- and alkali-resistant material.
- The hoses should be made in PVC.
- A reverse flow device enables attack of lime scale from both directions.
- A heating device enables the CIP solution to reach much better effect.
- The flow rate capacity depends on the size of the BPHE.

COMMERCIALLY AVAILABLE CIP FLUIDS

Bio Gen Active – Scale 132 Copper

Description: Scale 132 effectively removes lime scale and metal oxides (e.g. rust) without etching the material. It's used for reconditioning of waterborne systems. The product is mild to user, material and the environment.

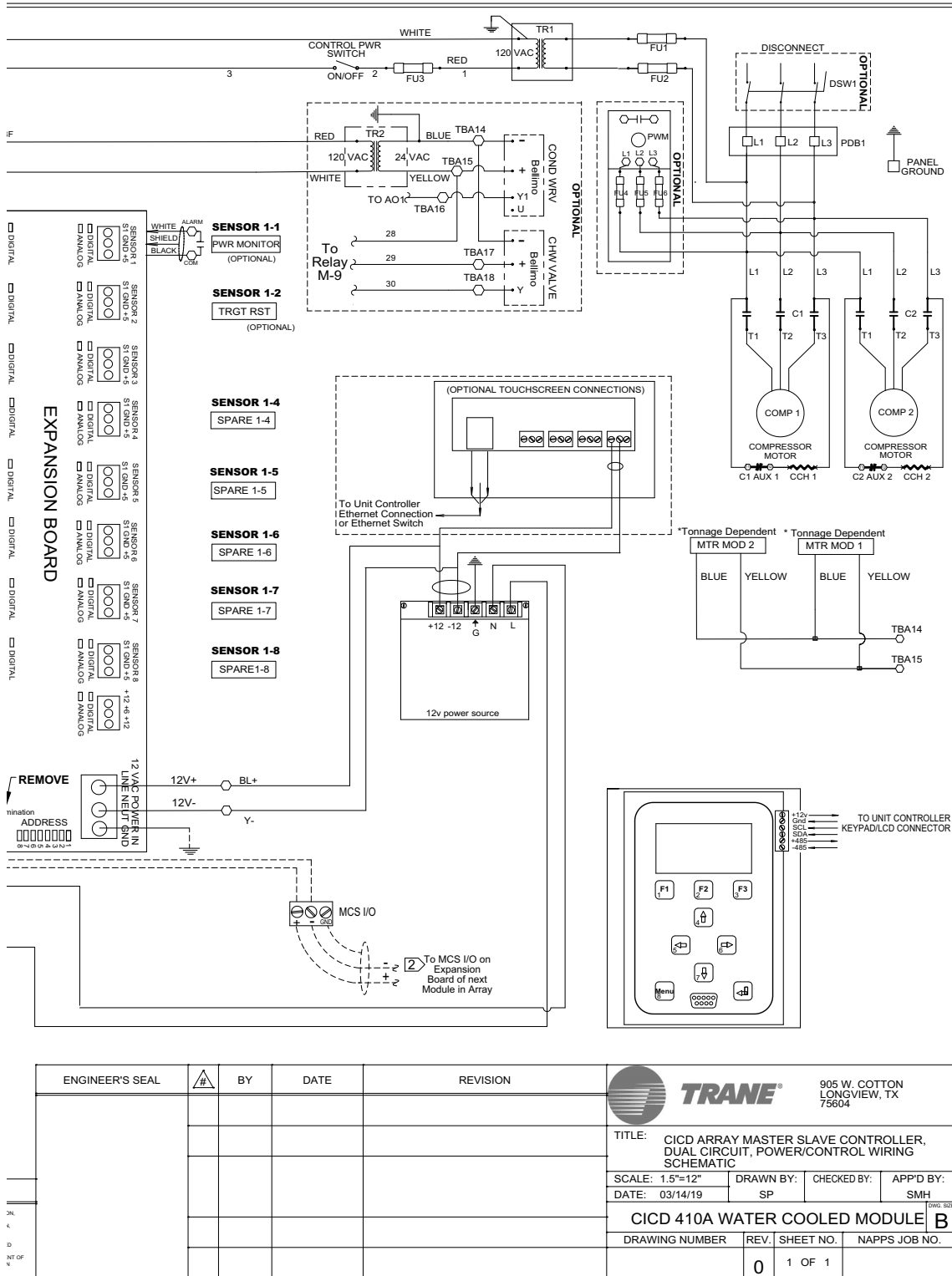
Figure 20. CIDC wiring schematic (continued)



ENGINEER'S SEAL	BY	DATE	REVISION	 905 W. COTTON LONGVIEW, TX 75604	
				TITLE: CIDC ARRAY MASTER SLAVE CONTROLLER, DUAL CIRCUIT, POWER/CONTROL WIRING SCHEMATIC	
				SCALE: 1.5"=12"	DRAWN BY: SMH
				DATE: 03/14/19	CHECKED BY: SP
				CIDC 410A WATER COOLED MODULE B	
				DRAWING NUMBER	REV. SHEET NO. NAPPS JOB NO.
				0	1 OF 1

Figure 21. CICD dual circuit secondary unit wiring schematic

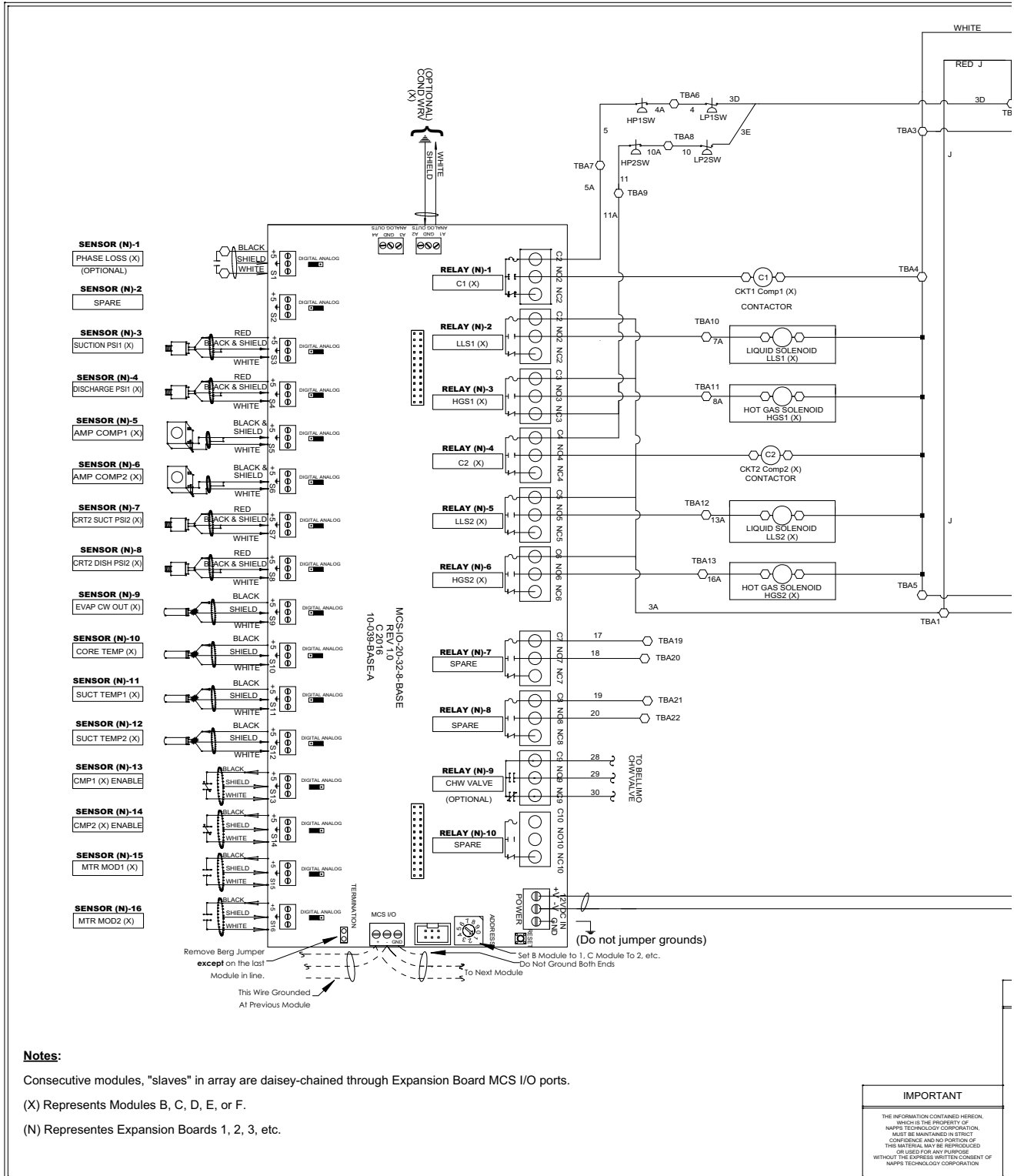
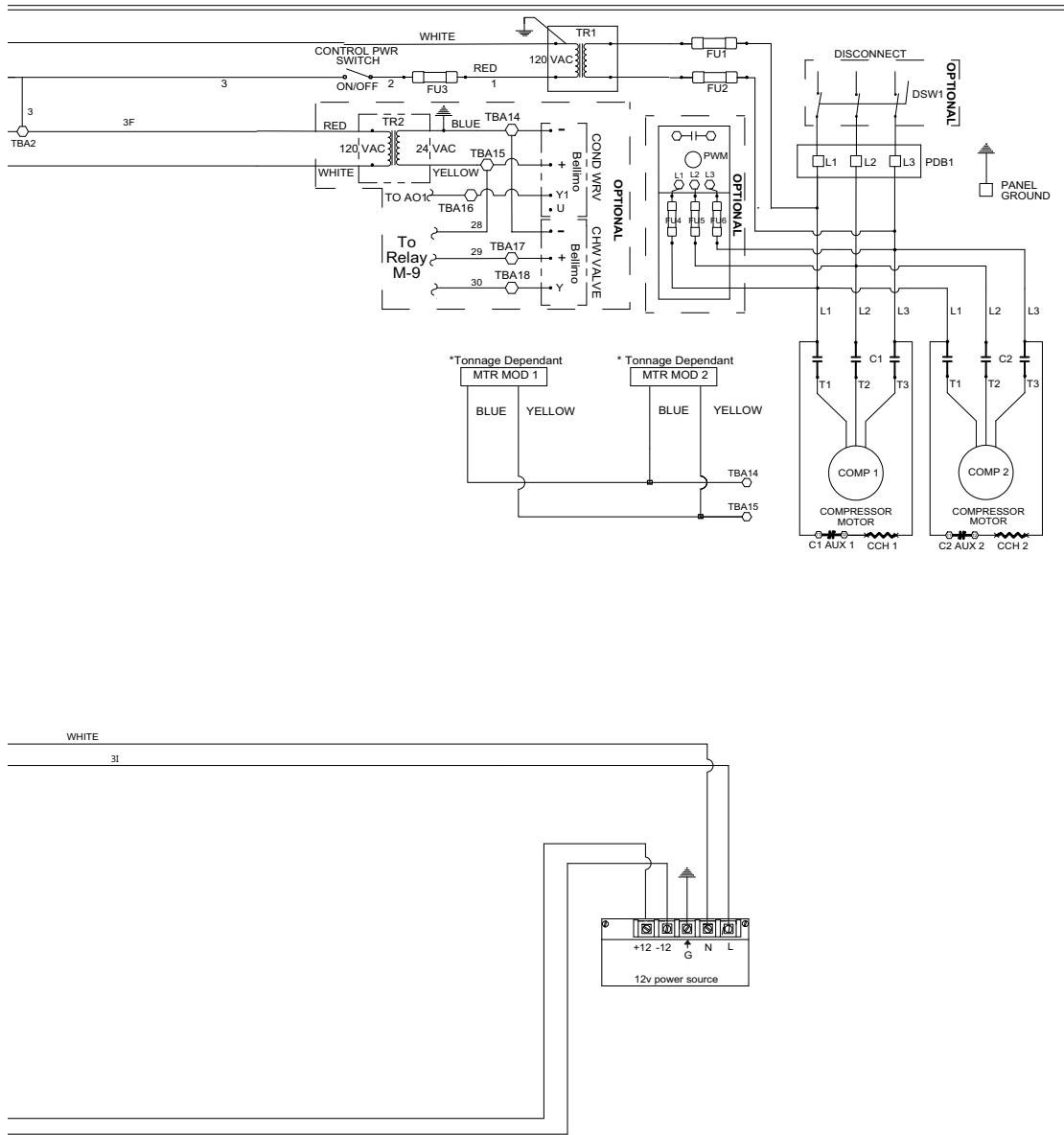

Figure 22. CICD dual circuit secondary unit wiring schematic (continued)



ENGINEER'S SEAL	BY	DATE	REVISION	905 W. COTTON LONGVIEW, TX 75604				
				TITLE: CICD DUAL CIRCUIT POWER/CONTROL WIRING SCHEMATIC - SLAVE MODULE				
				SCALE: 1.5"=12"	DRAWN BY: SP	CHECKED BY: BAR		
				DATE: 08/14/19		APP'D BY:		
				CICD 410A WATER COOLED MODULE DWG. SIZE				
				DRAWING NUMBER	REV.	SHEET NO.	NAPPS JOB NO.	
					0	1 OF 1		

Figure 23. Field wiring — CICD single unit, single circuit

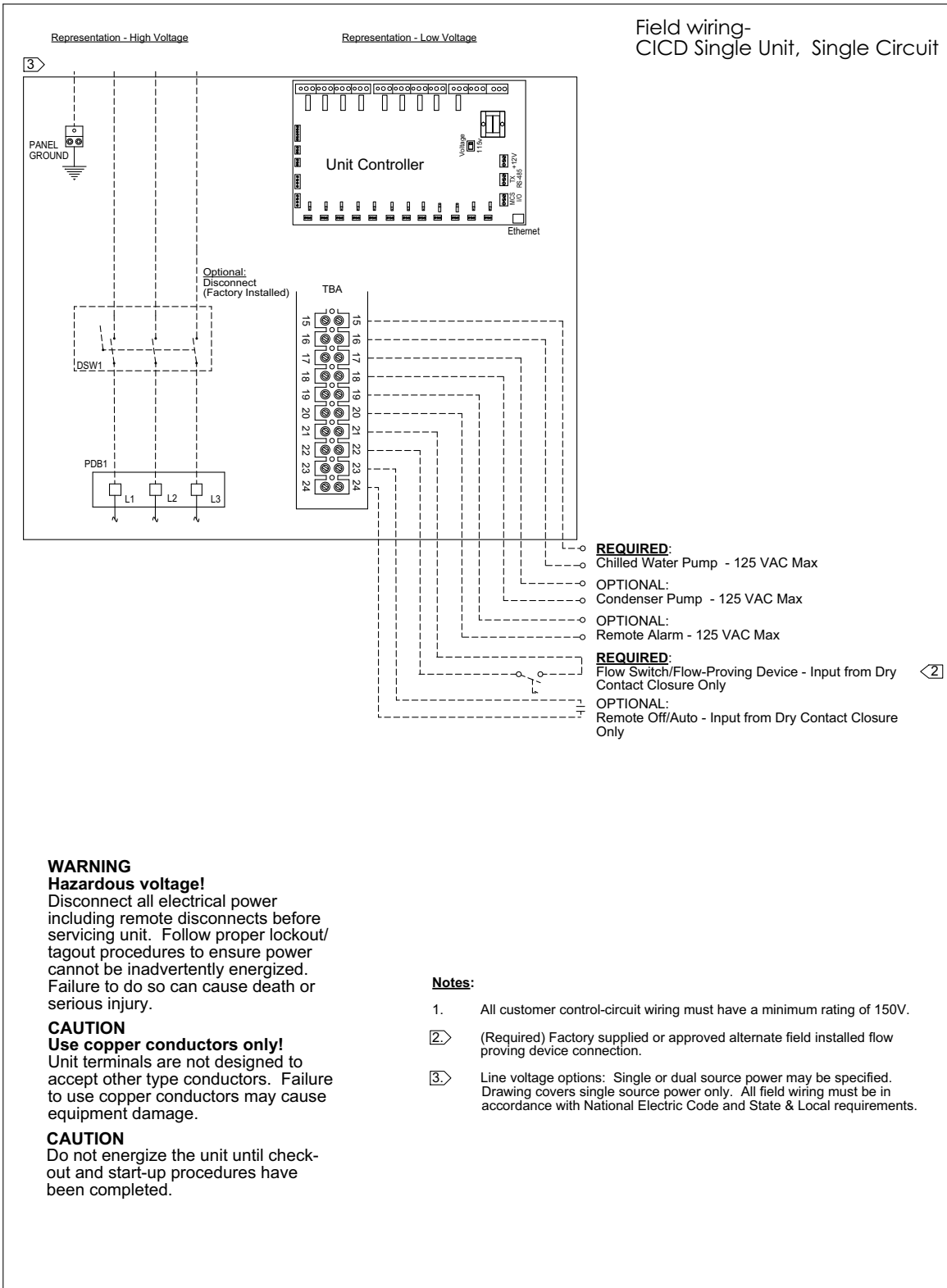

Figure 24. Field wiring — CICD single unit, dual circuit

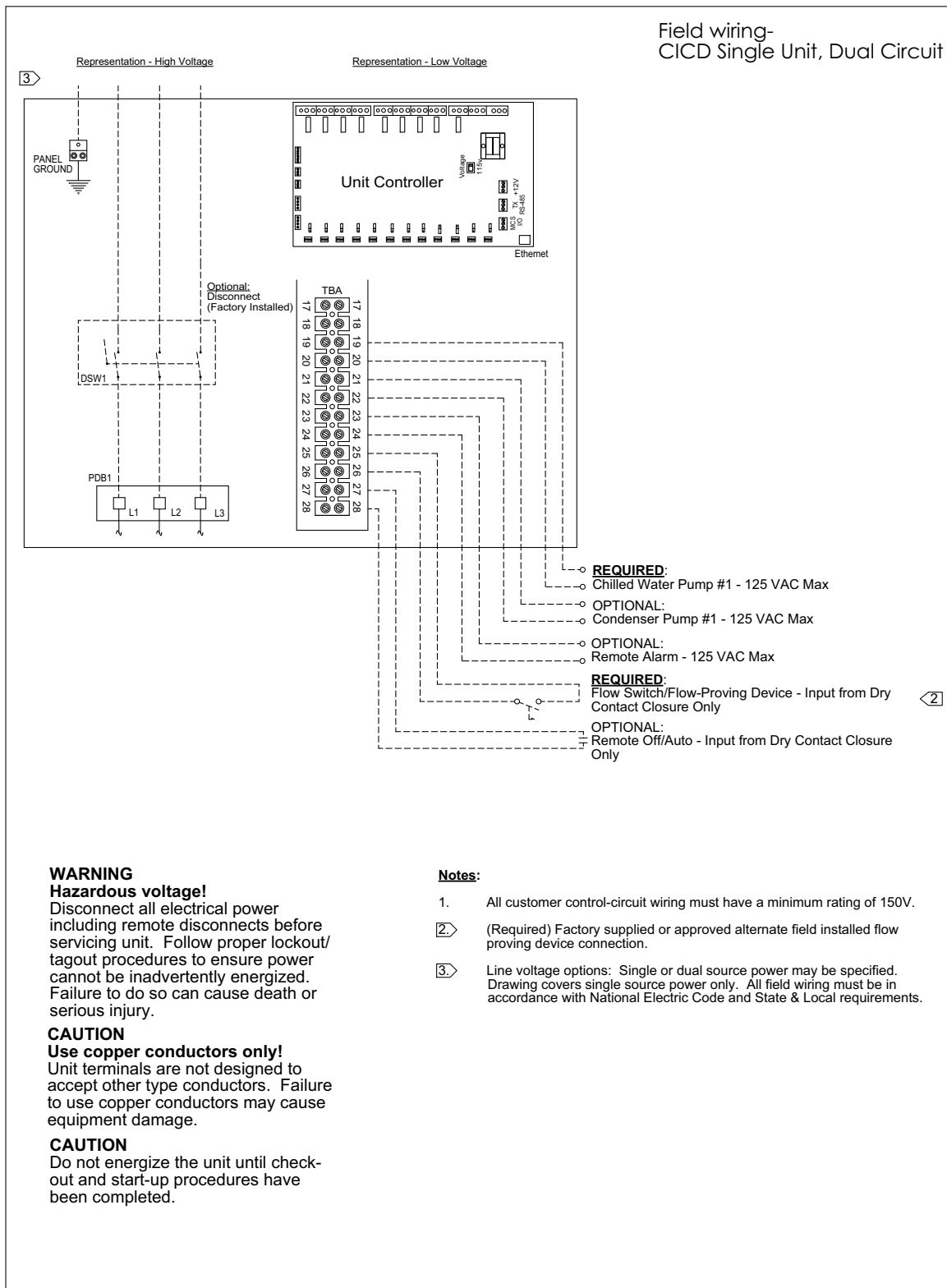

Figure 25. Field wiring — CICD array with manager/subordinate controller, single circuit modules

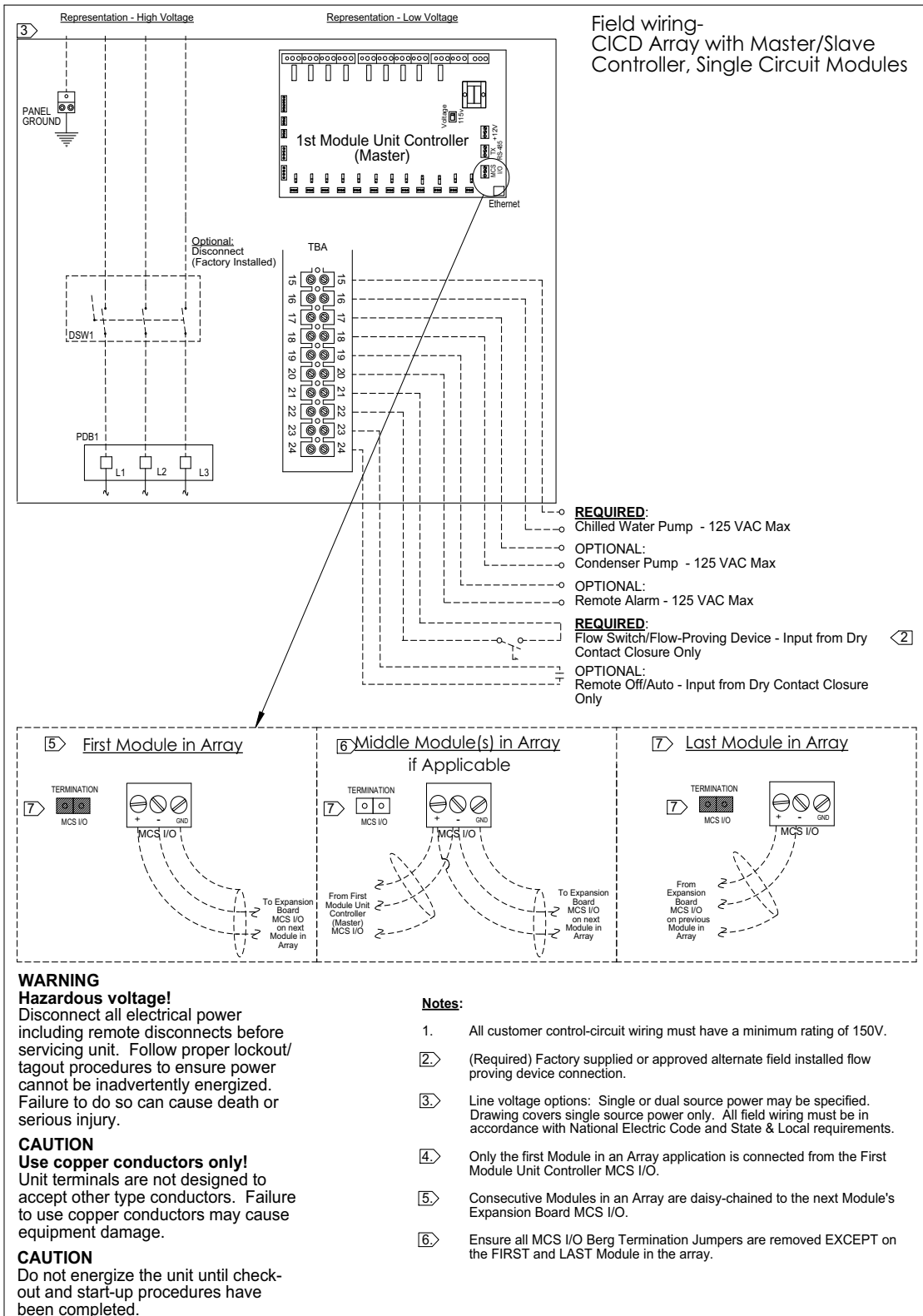

Figure 26. Field wiring — CICD array with manager/subordinate controller, dual circuit modules

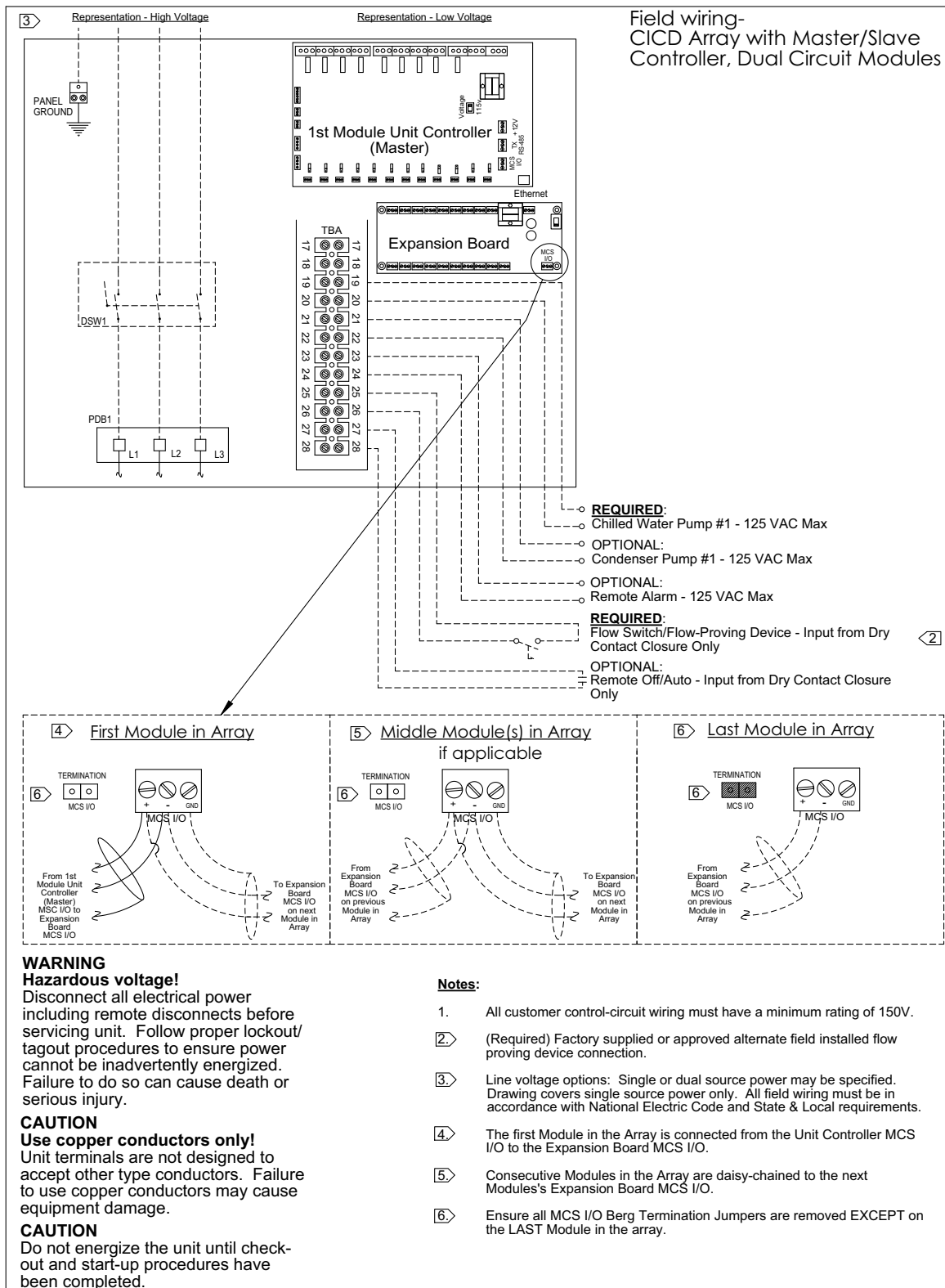

Figure 27. Field wiring — CICD array with supervisory controller, single circuit modules

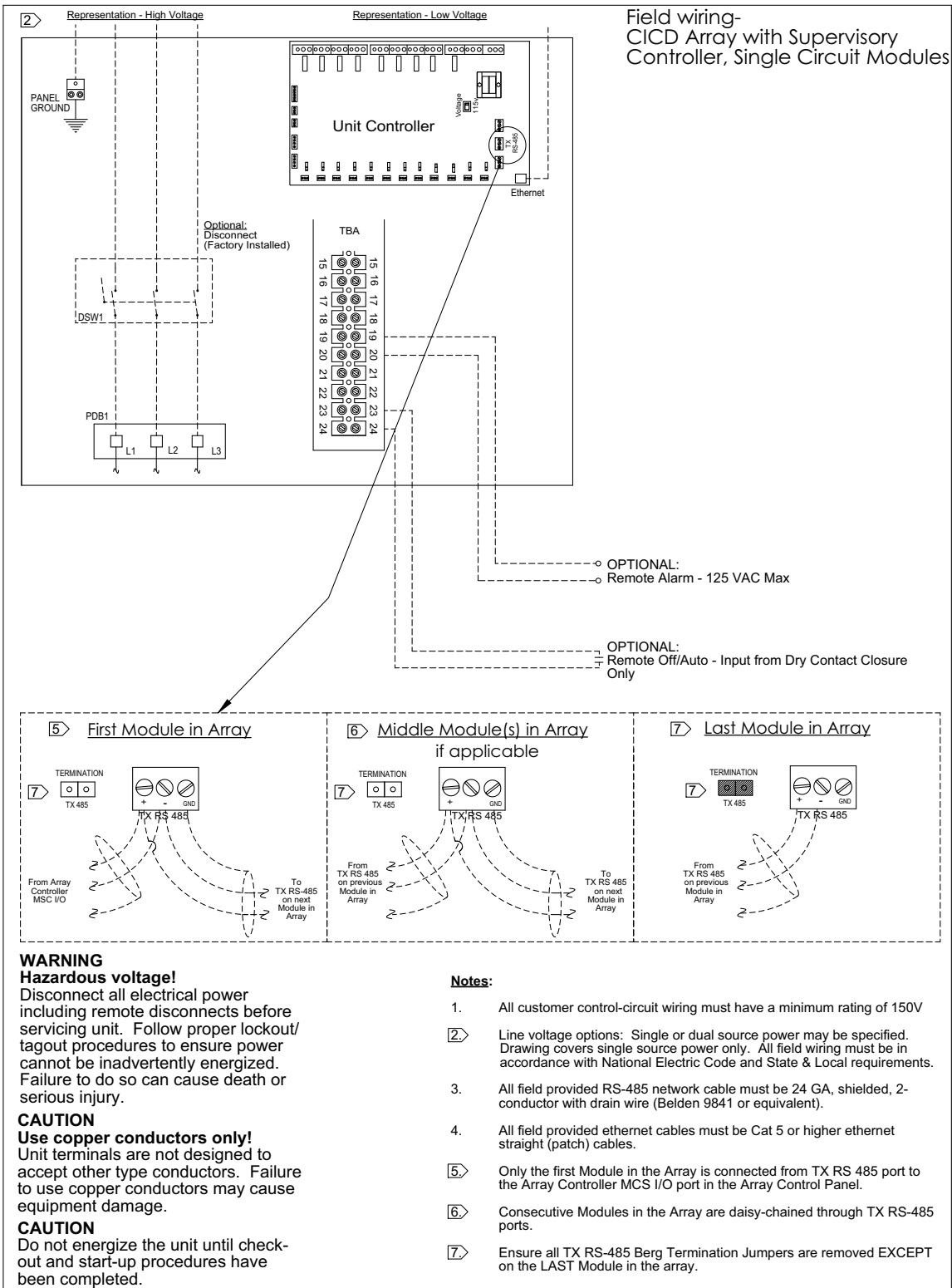

Figure 28. Field wiring — CICD array with supervisory controller, dual circuit modules

Figure 29. Field wiring — CICD array control panel



WARNING
Hazardous voltage!

Disconnect all electrical power including remote disconnects before servicing unit. Follow proper lockout/tagout procedures to ensure power cannot be inadvertently energized. Failure to do so cause death or serious injury.

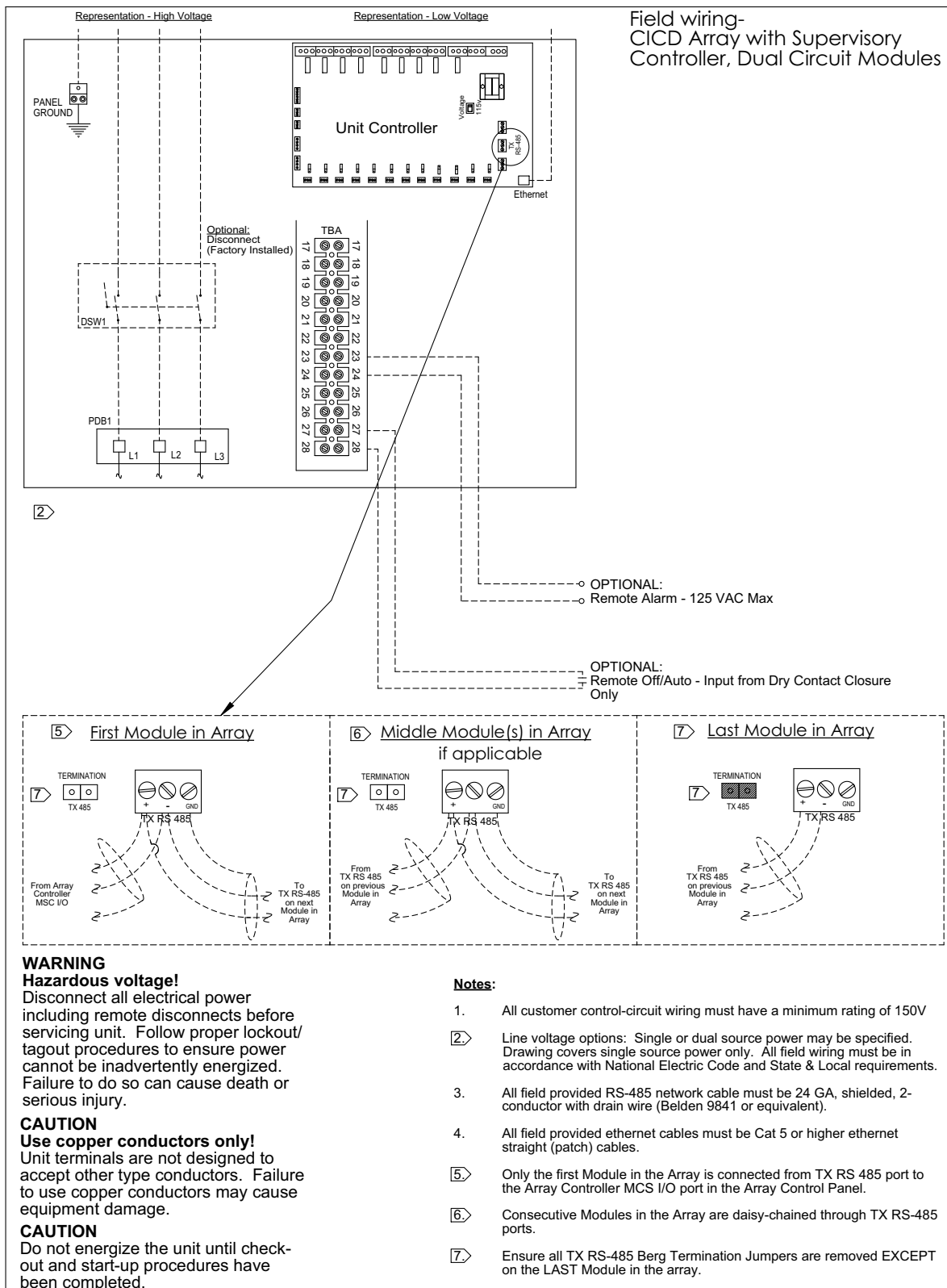
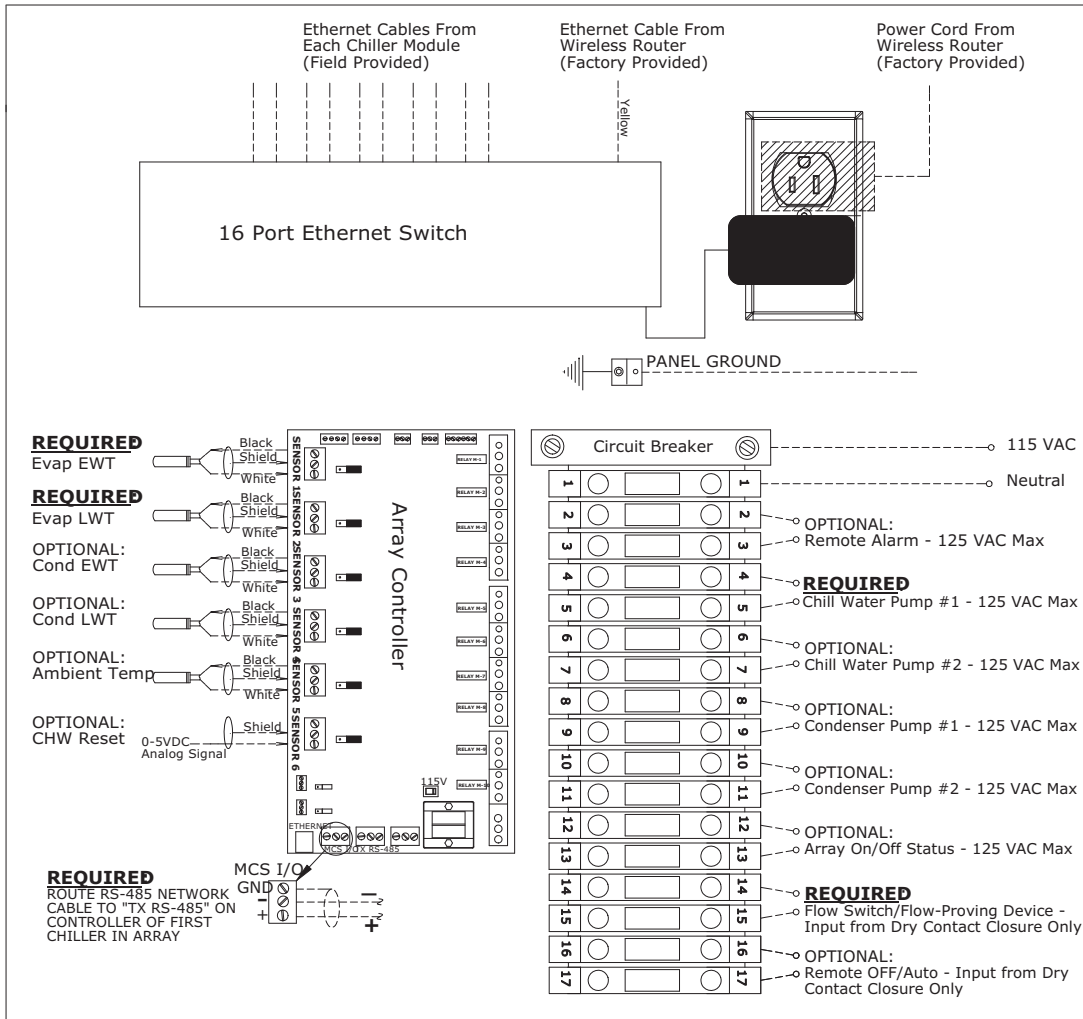
CAUTION
Use copper conductors only!

Unit terminals are not designed to accept other type conductors. Failure to use copper conductors may cause equipment damage.

CAUTION
Do not energize the unit until check-out and start-up procedures have been completed.

NOTES:

1. All field provided control-circuit wiring must have a minimum rating of 150V.
2. All wiring must be in accordance with NEC, State & Local requirements.
3. All field provided ethernet cables must be Cat 5 or higher ethernet straight (patch) cables.
4. All field provided RS-485 network cable must be 24 GA, shielded, 2-conductor with drain wire (Belden 9841 or equivalent)



Appendix A

Warranty

I. LIMITED PRODUCT WARRANTY & SERVICE POLICY

Napps Technology Corporation (NAPPS) warrants for a period of twelve (12) months from date of original shipment that all products, manufactured by NAPPS, with the exception of packaged refrigeration products, are free from defects of material and workmanship when used within the service, range, and purpose for which they were manufactured.

Packaged refrigeration products shall be so warranted for a period of twelve (12) months from date of start-up or eighteen (18) months from date of original shipment, whichever may first occur. Service Parts shall be so warranted for a period of ninety (90) days from date of installation, or twelve (12) months from date of original shipment, whichever may first occur.

In case material is rejected on inspection by the buyer as defective, NAPPS shall be notified in writing within ten (10) days from receipt of said material. NAPPS will then have the option of re-inspection at the buyer's plant or its own plant before allowing or rejecting the buyer's claim. Expenses incurred in connection with claims for which NAPPS is not liable may be charged back to the buyer. No claim for correction will be allowed for work done in the field except with the written consent of NAPPS. Defects that do not impair service shall not be cause for rejection. NAPPS assumes no liability in any event for consequential damages. No claim will be allowed for material damaged by the buyer or in transit. Defective equipment or parts shall be returned to NAPPS freight prepaid.

NAPPS will, at its option, repair, replace or refund the purchase price of products found by NAPPS to be defective in material or workmanship provided that written notice of such defect requesting instruction for repair, replacement or refund is received by NAPPS within ten (10) days of determination of said defect, but not more than one (1) year after the date of shipment, and provided that any instructions given thereafter by NAPPS are complied with.

Any products covered by this order found to NAPPS' satisfaction to be defective upon examination at NAPPS' factory will, at NAPPS' option, be repaired or replaced and returned to Buyer via lowest cost common carrier, or NAPPS may, at its option, grant Buyer a credit for the purchase price of the defective article.

This warranty does not cover and does not apply to:

- Fuses, refrigerant, fluids, oil.
- Products relocated after initial installation.
- Any portion or component of the system that is not supplied by NAPPS, regardless of the cause of the failure of such portion or component.
- Products on which the units identification tags or labels have been removed or defaced.
- Products on which payment to NAPPS is or has been in default.

- Products which have defects or damage which result from improper installation, wiring, electrical imbalance characteristics or maintenance (including, without limitation, defects or damages caused by voltage surges, inadequate voltage conditions, phase imbalance, any form of electrical disturbances, inadequate or improper electrical circuit installation or protection, failure to perform common maintenance, etc.); or are caused by accident, misuse or abuse, fire, the elements, shock, vibration, flood, alteration, misapplication of the product or to any other service, range or environment of greater severity than that for which the products were designed
- Products which have defects or damage which result from a contaminated or corrosive air or liquid supply, operation at abnormal temperatures, or unauthorized opening of refrigerant circuit.
- Products subjected to corrosion or abrasion or chemicals.
- Mold, fungus or bacteria damage.
- Products manufactured or supplied by others.
- Products which have been subjected to misuse, negligence, vandalism or accidents.
- Products which have been operated in a manner contrary to NAPPS' printed instructions.
- Products which have defects, damage or insufficient performance as a result of insufficient or incorrect system design or the improper application of NAPPS' products.
- Products which have defects or damages due to freezing of the water supply, an inadequate or interrupted water supply, corrosives or abrasives in the water supply, or improper or inadequate filtration or treatment of the water or air supply.
- water-to-refrigerant heat exchanger for any damage resulting from freezing, fouling, corrosion or clogging.

NAPPS is not responsible for:

- The costs of any fluids, oils refrigerant or other system components, or the associated labor to repair or replace the same, which is incurred as a result of a defective part covered by NAPPS' Limited Product Warranty.
- The costs of labor, refrigerant, materials or service incurred in removal of the defective part, or in obtaining and replacing the new or repaired part; or,
- Transportation costs of the defective part from the installation site to NAPPS or the return of any part not covered by NAPPS' Limited Product Warranty.

Additional charges, which may be incurred through the substitution of other than identical replacements, are not covered by this warranty. Evaporator failure due to fluid freezing that is the result of low fluid flow or inadequate fluid freeze protection, for applications with leaving fluid temperatures below 40° F, is not covered by this warranty

THE WARRANTY PROVIDED ABOVE IS THE ONLY WARRANTY MADE BY NAPPS WITH RESPECT TO ITS



Appendix A

PRODUCTS OR ANY PARTS THEREFORE AND IS MADE EXPRESSLY IN LIEU OF ANY OTHER WARRANTIES, BY COURSE OF DEALING, USAGES OF TRADE OR OTHERWISE, EXPRESSED OR IMPLIED, INCLUDING BUT NOT LIMITED TO ANY IMPLIED WARRANTIES OF FITNESS FOR ANY PARTICULAR PURPOSE OR OF MERCHANTABILITY UNDER THE UNIFORM COMMERCIAL CODE. IT IS AGREED THAT THIS WARRANTY IS IN LIEU OF AND BUYER HEREBY WAIVES ALL OTHER WARRANTIES, GUARANTEES OR LIABILITIES ARISING BY LAW OR OTHERWISE. NAPPS SHALL NOT INCUR ANY OTHER, OBLIGATIONS OR LIABILITIES OR BE LIABLE TO BUYER OR ANY CUSTOMER OF BUYER FOR ANY ANTICIPATED OR LOST PROFITS, INCIDENTAL OR CONSEQUENTIAL DAMAGES, OR ANY OTHER LOSSES OR EXPENSES INCURRED BY REASON OF THE PURCHASE, INSTALLATION, REPAIR, USE OR MISUSE BY BUYER OR THIRD PARTIES OF ITS PRODUCTS (INCLUDING ANY PARTS REPAIRED OR REPLACED); AND NAPPS DOES NOT AUTHORIZE ANY PERSON TO ASSUME FOR NAPPS ANY OTHER LIABILITY IN CONNECTION WITH THE PRODUCTS OR PARTS THEREFORE. NAPPS SHALL NOT BE RESPONSIBLE FOR THE LOSS OR REPLACEMENT OF OR THE ADDITION OF COMPRESSOR OIL, OR REFRIGERANT. THIS WARRANTY CANNOT BE EXTENDED, ALTERED OR VARIED EXCEPT BY A WRITTEN INSTRUMENT SIGNED BY NAPPS AND BUYER.

II. LIMITATION OF LIABILITY

NAPPS shall not be liable, in contract or in tort, for any special, indirect, incidental or consequential damages, such as, but not limited to, loss of profits, or injury or damage caused to property, products, or persons by reason of the installation, modification, use, repair, maintenance or mechanical failure of any NAPPS product.



Appendix B

Piping System Flushing Procedure

Prior to connecting the chiller to the condenser and chilled water loop, the piping loops shall be flushed with a detergent and hot water (110-130°F) mixture to remove previously accumulated dirt and other organics. In old piping systems with heavy encrustation of inorganic materials consult a water treatment specialist for proper passivation and/or removal of these contaminants.

During the flushing, 30 mesh (max.) Y-strainers (or acceptable equivalent) shall be in place in the system piping and examined periodically as necessary to remove collected residue. The use of on-board chiller strainers shall not be acceptable. The flushing process shall take no less than 6 hours or until the strainers when examined after each flushing are clean. Old systems with heavy encrustation shall be flushed for a minimum of 24 hours and may take as long as 48 hours before the filters run clean. Detergent and acid concentrations shall be used in strict accordance with the respective chemical manufacturer's instructions. After flushing with the detergent and/or dilute acid concentrations the system loop shall be purged with clean water for at least one (1) hour to ensure that all residual cleaning chemicals have been flushed out.

Prior to supplying water to the chiller the Water Treatment Specification shall be consulted for requirements regarding the water quality during chiller operation. The appropriate chiller manufacturer's service literature shall be available to the operator and/or service contractor and consulted for guidelines concerning preventative maintenance and off-season shutdown procedures.

Water Treatment Requirements

Supply water for both the chilled water and condenser water circuits shall be analyzed and treated by a professional water treatment specialist who is familiar with the operating conditions and materials of construction specified for the chiller's heat exchangers, headers and associated piping. Cycles of concentration shall be controlled such that recirculated water quality for compact chillers using 316 stainless steel brazed plate heat exchangers and carbon steel headers is maintained within the following parameters.

Table 6. Water property limits

Water Property	Concentration Limits
Alkalinity (HCO ₃ ⁻)	70-300 ppm
Sulfate (SO ₄ ²⁻)	Less than 70 ppm
HCO ₃ ⁻ / SO ₄ ²⁻	Greater than 1.0
Electrical Conductivity	10 - 500 μS/cm
pH	7.5 – 9.0
Ammonia (NH ₃)	Less than 2 ppm
Chlorides (Cl ⁻)	Less than 300 ppm
Free Chlorine (Cl ₂)	Less than 1 ppm
Hydrogen Sulfide (H ₂ S)	Less than 0.05 ppm
Free (aggressive) Carbon Dioxide (CO ₂)	Less than 5 ppm
Total Hardness (°dH)	4.0 - 8.5
Nitrate (NO ₃)	Less than 100 ppm
Iron (Fe)	Less than 0.2 ppm
Aluminum (Al)	Less than 0.2 ppm
Manganese (Mn)	Less than 0.1 ppm

Trane - by Trane Technologies (NYSE: TT), a global climate innovator - creates comfortable, energy efficient indoor environments for commercial and residential applications. For more information, please visit trane.com or tranetechnologies.com.

Trane has a policy of continuous product and product data improvement and reserves the right to change design and specifications without notice. We are committed to using environmentally conscious print practices.