



Installation, Operation, and Maintenance

Cold Generator™ Scroll Liquid Chillers Model CGWR and CCAR

20 to 75 Tons (60 Hz)
Water-Cooled and Compressor Chillers



SAFETY WARNING

Only qualified personnel should install and service the equipment. The installation, starting up, and servicing of heating, ventilating, and air-conditioning equipment can be hazardous and requires specific knowledge and training. Improperly installed, adjusted or altered equipment by an unqualified person could result in death or serious injury. When working on the equipment, observe all precautions in the literature and on the tags, stickers, and labels that are attached to the equipment.



Introduction

Read this manual thoroughly before operating or servicing this unit.

Warnings, Cautions, and Notices

Safety advisories appear throughout this manual as required. Your personal safety and the proper operation of this machine depend upon the strict observance of these precautions.

The three types of advisories are defined as follows:

- WARNING** Indicates a potentially hazardous situation which, if not avoided, could result in death or serious injury.
- CAUTION** Indicates a potentially hazardous situation which, if not avoided, could result in minor or moderate injury. It could also be used to alert against unsafe practices.
- NOTICE** Indicates a situation that could result in equipment or property-damage only accidents.

Important Environmental Concerns

Scientific research has shown that certain man-made chemicals can affect the earth's naturally occurring stratospheric ozone layer when released to the atmosphere. In particular, several of the identified chemicals that may affect the ozone layer are refrigerants that contain Chlorine, Fluorine and Carbon (CFCs) and those containing Hydrogen, Chlorine, Fluorine and Carbon (HCFCs). Not all refrigerants containing these compounds have the same potential impact to the environment. Trane advocates the responsible handling of all refrigerants.

Important Responsible Refrigerant Practices

Trane believes that responsible refrigerant practices are important to the environment, our customers, and the air conditioning industry. All technicians who handle refrigerants must be certified according to local rules. For the USA, the Federal Clean Air Act (Section 608) sets forth the requirements for handling, reclaiming, recovering and recycling of certain refrigerants and the equipment that is used in these service procedures. In addition, some states or municipalities may have additional requirements that must also be adhered to for responsible management of refrigerants. Know the applicable laws and follow them.

WARNING

Proper Field Wiring and Grounding Required!

Failure to follow code could result in death or serious injury. All field wiring **MUST** be performed by qualified personnel. Improperly installed and grounded field wiring poses **FIRE** and **ELECTROCUTION** hazards. To avoid these hazards, you **MUST** follow requirements for field wiring installation and grounding as described in **NEC** and your local/state/national electrical codes.

WARNING

Personal Protective Equipment (PPE) Required!

Failure to wear proper PPE for the job being undertaken could result in death or serious injury. Technicians, in order to protect themselves from potential electrical, mechanical, and chemical hazards, **MUST** follow precautions in this manual and on the tags, stickers, and labels, as well as the instructions below:

- Before installing/servicing this unit, technicians **MUST** put on all PPE required for the work being undertaken (Examples; cut resistant gloves/sleeves, butyl gloves, safety glasses, hard hat/bump cap, fall protection, electrical PPE and arc flash clothing). **ALWAYS** refer to appropriate Safety Data Sheets (SDS) and OSHA guidelines for proper PPE.
- When working with or around hazardous chemicals, **ALWAYS** refer to the appropriate SDS and OSHA/GHS (Global Harmonized System of Classification and Labeling of Chemicals) guidelines for information on allowable personal exposure levels, proper respiratory protection and handling instructions.
- If there is a risk of energized electrical contact, arc, or flash, technicians **MUST** put on all PPE in accordance with OSHA, NFPA 70E, or other country-specific requirements for arc flash protection, **PRIOR** to servicing the unit. **NEVER PERFORM ANY SWITCHING, DISCONNECTING, OR VOLTAGE TESTING WITHOUT PROPER ELECTRICAL PPE AND ARC FLASH CLOTHING. ENSURE ELECTRICAL METERS AND EQUIPMENT ARE PROPERLY RATED FOR INTENDED VOLTAGE.**

⚠ WARNING**Follow EHS Policies!**

Failure to follow instructions below could result in death or serious injury.

- All Trane personnel must follow the company's Environmental, Health and Safety (EHS) policies when performing work such as hot work, electrical, fall protection, lockout/tagout, refrigerant handling, etc. Where local regulations are more stringent than these policies, those regulations supersede these policies.
- Non-Trane personnel should always follow local regulations.

Copyright

This document and the information in it are the property of Trane, and may not be used or reproduced in whole or in part without written permission. Trane reserves the right to revise this publication at any time, and to make changes to its content without obligation to notify any person of such revision or change.

Trademarks

All trademarks referenced in this document are the trademarks of their respective owners.

Revision History

Updated Unit Controller section in Electrical Wiring chapter.



Table of Contents

Model Number Descriptions	6	Flow Proving Device — Required	21
Unit Components	7	Chilled Water System Volume	21
General Data	8	Condenser Water Piping	21
Ambient Limits — CCAR/CAUJ Combination	9	Discharge Pressure Control/Optional Factory- Installed Water Regulating Valve	21
Minimum Ambient Temperature Limit	9	Water Pressure Drop Curves	24
Maximum Ambient Temperature Limit	9	Low Suction Temperature and Pressure Cutouts/ Percent Glycol Recommendations	25
Inspection Check List and Unit Identification	10	Refrigerant Piping (CCAR only)	26
Unit Description	10	General Guidelines	26
Electrical Data	11	Liquid Line	26
Dimensions and Weights	12	Discharge (Hot Gas) Line	26
Dimensions	12	Initial Leak Test	27
Weights	16	Refrigerant Piping Sizes	27
Installation	17	Final Leak Test	27
General Installation Information	17	System Evacuation	27
Storage	17	Refrigerant Charging	27
Noise Considerations	17	Electrical Wiring	28
Foundation	17	General Recommendations	28
Clearances	17	Power and Control Wiring	28
Ventilation	18	Unit Power Wiring	28
Drainage	18	Scroll Compressor Electrical Phasing	28
Handling	18	Setting Proper Electrical Phase Sequence	28
Rigging/Lifting Procedure	18	Unit Voltage	29
Access Restrictions	19	Voltage Supply	29
Direct Mounting	19	Voltage Imbalance	29
Neoprene Isolator Pad Mounting (Optional)	19	Control Power Supply	29
Compressor Mounting	19	External Contacts	29
Unit Leveling	19	Chilled Water Flow Switch	29
Compressor Nameplate	19	CCAR Condenser Fan Staging or VFD Control	30
Evaporator Nameplate	19	CGWR Condenser Water Loss of Flow Protection	30
Condenser Nameplate	19	CGWR Condenser Control	30
Unit Piping	20	Equipment Grounds	30
Water Piping — General	20	Unit Controller	30
Water Flow Rates	20	Unit Controller — Software Installation and Setup	32
Water Treatment	20	Downloading and Installing Unit Controller (MCS-Connect) Software	32
Chilled Water Piping	20		
Braze Plate Evaporator	20		
Wye Strainer — Required	21		

Connecting to the Chiller	32	I. Limited Product Warranty and Service	
Set Point Changes	32	Policy	67
Viewing and Troubleshooting ALARMS	32	II. Limitation Of Liability	68
Downloading and Viewing Graphs	32		
Updating Chiller Software and Configuration			
Files	32		
Unit Start-Up Procedures	34		
Pre-Start Up Procedures Check List	34		
Sequence of Operation	34		
Checking Operating Conditions	35		
Unit Shutdown	36		
Normal Unit Shutdown	36		
Extended Shutdown Procedure	36		
Unit Restart	37		
Unit Restart After Extended Shutdown	37		
Maintenance	38		
Compressor Oil	38		
Scroll Compressor Functional Test	38		
Compressor Operational Noises	39		
Excessive Amp Draw	39		
Low Suctions	39		
Periodic Maintenance	39		
Weekly Maintenance	39		
Monthly Maintenance	40		
Annually	40		
Electrical Schematics	41		
CGWR Water-Cooled Chillers	41		
CGWR Field Wiring	41		
CGWR Power/Control Wiring	42		
CCAR Compressor Chillers	50		
CCAR Field Wiring	50		
CCAR Power/Control Wiring	52		
Appendix	64		
Vendor Data Sheet	64		
MCS-CT300 Current Transducer Data			
Sheet	64		
MCS-667C Pressure Transducer Data			
Sheet	65		
The MCS-T100 Specifications and			
Description	66		
Warranty	67		



Model Number Descriptions

Digit 1, 2, 3, 4 — Unit Type

CGWR = Water-cooled chiller
CCAR = Compressor chiller

Digit 5, 6, 7 — Unit Nominal

Tonnage

020 = 20 Nominal tons
030 = 30 Nominal tons
040 = 40 Nominal tons
050 = 50 Nominal tons
065 = 65 Nominal tons
075 = 75 Nominal tons

Digit 8 — Unit Voltage

A = 208V/60/3
B = 230V/60/3
F = 460V/60/3
G = 575V/60/3

Digit 9, 10 — Design Sequence

A0 = Factory assigned

Digit 11 — Agency Listing

N = None
E = ETL/ETL-C Listed to meet U.S. and Canadian safety standards

Digit 12 — Condenser Water Regulating Valve

0 = None
1 = With

Digit 13 — Evaporator Wye Strainer

0 = None
1 = Nominal flow wye strainer
2 = Nominal flow wye strainer with installation kit¹

Digit 14 — Evaporator Temp Range

0 = Standard cooling
42 to 60°F [4.4 to 5.5°C]
1 = Standard cooling/ice making
20 to 60°F [-6.7 to 15.6°C]

Digit 15 — Power Connection

T = Terminal block
D = Non-fused disconnect switch
F = Fused disconnect switch

Digit 16 — Short Circuit Rating (SCCR)

0 = Standard 5 kA rating
1 = Optional 100 kA rating

Digit 17 — Sound Attenuator

0 = No sound attenuation
3 = Compressor sound blanket(s)
9 = Factory sound enclosure cabinet(s)

Digit 18 — Local Unit Controller Interface

0 = Keypad with dot pixel display
1 = Color touchscreen

Digit 19 — Remote BMS Interface (Digital Comm)

0 = None
2 = LonTalk®
4 = BACnet® Ms/TP
5 = BACnet IP
6 = MODBUS®
8 = Johnson N2

Digit 20 — Power Monitor

0 = None
1 = With

Digit 21 — Neoprene Isolator Pads

0 = None
1 = With

Digit 22 — Flow Switch

0 = None
1 = With

Digit 23 — Evaporator Fluid Type

0 = Water
2 = Ethylene glycol
3 = Propylene glycol

Digit 24 — Condenser Fluid Type

0 = Water
2 = Ethylene glycol
3 = Propylene glycol
9 = Not applicable — compressor-chiller

Digit 25 — Special Options

0 = None
1 = With

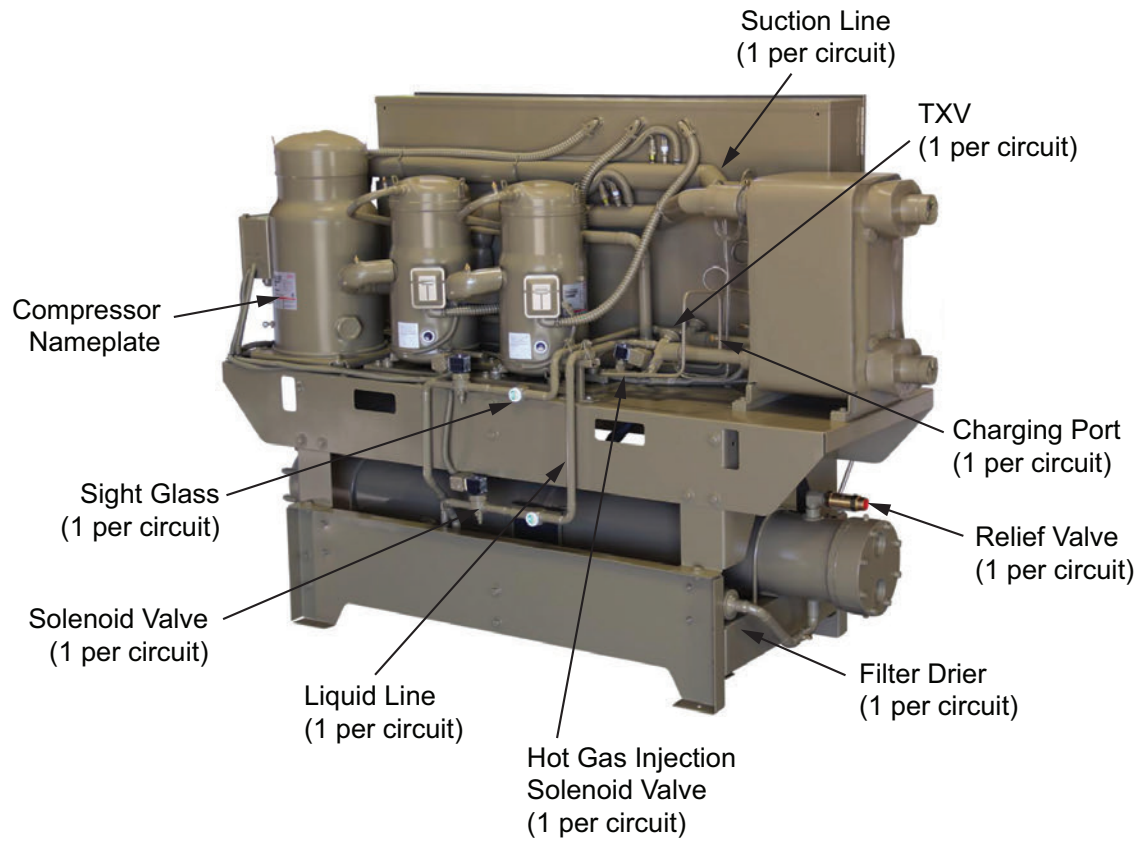
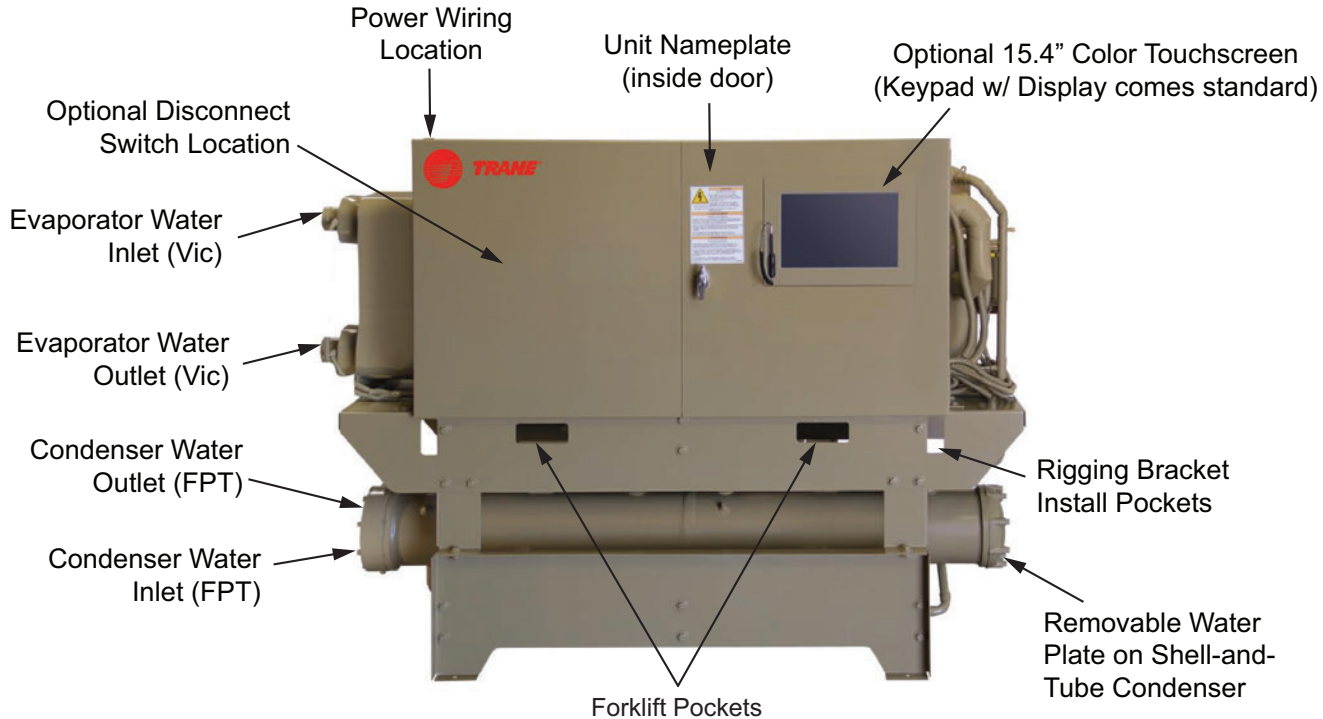
Digit 26 — Heat Recovery

0 = No heat recovery
1 = Full heat recovery with auto changeover

¹ Nominal flow wye strainer installation kit includes pipe adaptors and blowdown valve.



Unit Components





General Data

Table 1. General data for CGWR water-cooled chillers

Unit Size			20	30	40	50	65	75
Compressor								
Quantity	each		2	2	3	3	3	3
Nominal Tons @ 60 Hz	tons		10/10	15/15	10/10, 20	12/12, 25	15/15, 30	15/15, 40
Steps of Unloading	%		100-50	100-50	100-75-50-25	100-75-50-25	100-75-50-25	100-79-57-21
Compressor Sound Power Data ^(a)	dBA		81.0	84.0	87.2	87.5	90.2	91.8
Compressor Sound Data with Sound Blankets Only ^(a)	dBA		75.0	78.0	82.8	83.0	85.8	87.5
Evaporator								
Water Storage	gal		2.1	3.0	3.1	3.7	4.6	6.6
Minimum Flow	gpm		30	45	66	82	104	75
Maximum Flow	gpm		104	151	207	237	295	264
Shell and Tube Condenser								
Water Storage	gal		3.0	4.5	5.5	7.4	9.2	9.2
Minimum Flow	gpm		28	39	49	65	84	84
Maximum Flow	gpm		119	167	207	271	342	342
General Unit								
Refrigerant			R-410A	R-410A	R-410A	R-410A	R-410A	R-410A
Number of Independent Refrigerant Circuits			1	1	2	2	2	2
Refrigerant Charge Per Circuit (approximately)	lb		25	37	24, 24	26, 26	31, 31	33, 33
Oil Type			POE 160SZ	POE 160SZ	POE 160SZ	POE 160SZ	POE 160SZ	POE 160SZ
Oil Charge (each compressor)	oz		112/112	113/113	112/112, 227	112/112, 227	112/112, 227	112/112, 227

Notes:

1. Data containing information on two circuits formatted as follows: Circuit 1, Circuit 2.
2. Nominal compressor sizes based on 60 Hz.

(a) Compressor manufacturer sound power is given at rated compressor AHRI conditions measured in free space for tandem compressor sets.

Table 2. General data for CCAR compressor chillers

Unit Size			20	30	40	50	65	75
Compressor								
Quantity	each		2	2	3	3	3	3
Nominal Tons @ 60 Hz	tons		10/10	15/15	10/10, 20	12/12, 25	15/15, 30	15/15, 40
Steps of Unloading	%		100-50	100-50	100-75-50-25	100-75-50-25	100-75-50-25	100-79-57-21
Compressor Sound Power Data ^(a)	dBA		81.0	84.0	87.2	87.5	90.2	91.8
Compressor Sound Data with Sound Blankets Only ^(a)	dBA		75.0	78.0	82.8	83.0	85.8	87.5
Evaporator								
Water Storage	gal		2.1	3.0	3.1	3.7	4.6	6.6
Minimum Flow	gpm		30	45	66	82	104	75
Maximum Flow	gpm		104	151	207	237	295	264
General Unit								
Refrigerant			R-410A	R-410A	R-410A	R-410A	R-410A	R-410A
Number of Independent Refrigerant Circuits			1	1	2	2	2	2
Refrigerant Charge Per Circuit (approximately)	lb		16	19	12, 12	13, 13	16, 16	17, 17
Oil Type			POE 160SZ	POE 160SZ	POE 160SZ	POE 160SZ	POE 160SZ	POE 160SZ
Oil Charge (each compressor)	oz		112/112	113/113	112/112, 227	112/112, 227	112/112, 227	112/112, 227

Notes:

1. Data containing information on two circuits formatted as follows: Circuit 1, Circuit 2.
2. Nominal compressor sizes based on 60 Hz.

(a) Compressor manufacturer sound power is given at rated compressor AHRI conditions measured in free space for tandem compressor sets.

Ambient Limits — CCAR/CAUJ Combination

Minimum Ambient Temperature Limit

Refer to *Pairing Trane CCAR Compressor Chillers (20 to 75 tons) with Trane CAUJ Air-Cooled Condensers (20 to 80 tons) Application Guide (SS-APG014*-EN)*.

In general, the minimum outdoor ambient temperature for operation of CCAR compressor chiller in combination with a CAUJ air cooled condenser is 40°F. In some cases, with factory application approval, the CCAR/CAUJ combination can be operated down to the 20°F ambient.

This minimum is primarily driven by compressor chiller starting considerations and not by effectiveness of condenser ambient controls once the system is up and running. Fan cycling and optimal low ambient dampers do *not* mitigate the low ambient starting challenge. On a cold day with outdoor ambient temperature below 40°F, the liquid line pressure at the expansion valve inlet, in most circumstances, is extremely low. On start, the suction pressure tends to plunge into the freezing range potentially causing a nuisance fault.

Contact the factory to request application approval for applications where CCAR/CAUJ combination is intended for operation with ambient temperature below 40°F.

Maximum Ambient Temperature Limit

The maximum ambient temperature limit for the CCAR/CAUJ operation is 110°F.



Inspection Check List and Unit Identification

To protect against loss due to damage incurred in transit, complete the following checklist upon receipt of the unit.

- Inspect the individual pieces of the shipment before accepting the unit. Check for obvious damage to the unit or packing material.
- Inspect the unit for concealed damage as soon as possible after delivery and before it is stored. Concealed damage must be reported within 15 days.
- If concealed damage is discovered, stop unpacking the shipment. Do not remove damaged material from the receiving location. Take photos of the damage, if possible. The owner must provide reasonable evidence that the damage did not occur after delivery.
- Notify the carrier's terminal of the damage immediately, by phone and by mail. Request an immediate, joint inspection of the damage with the carrier and the consignee.
- Notify the Trane sales representative and arrange for repair. Do not repair the unit, however, until damage is inspected by the carrier's representative.

After completing the inspection checklist, identify the unit with the unit nameplate, packing list and ordering information. The unit nameplate is mounted inside the control box.

Refer to "[Model Number Descriptions](#)," p. 6 for additional data that can be found on the nameplate.

Check all items against the shipping list. Verify that it is the correct unit and that it is properly equipped. If optional neoprene or spring isolators (or other ship-loose items) are ordered, they are secured in place on the shipping skid or inside the unit control box.

The Installation, Operation, and Maintenance manual can also be found in the unit control box. Be sure to read all of this literature before installing and operating the unit.

Unit Description

Trane CGWR water-cooled chillers and CCAR compressor chillers (condenserless chillers) are designed for installation on a prepared surface in a suitable, weatherproof location above freezing (32°F).

- CGWR/CCAR 20 and 30 ton chiller units have one refrigerant circuit fitted with a manifolded scroll compressor set piped in parallel.
- CGWR/CCAR 40, 50, 65 and 75 ton chiller units have two refrigerant circuits. One refrigerant circuit is fitted with a manifolded scroll compressor set piped in parallel, and the other refrigerant circuit has a single scroll compressor.

Units also have brazed plate evaporator, shell-and-tube condenser (CGWR only) and control box with integral control panel, all mounted on a common frame.

Each unit is completely assembled with refrigerant piping, power and control wiring, and top coated with executive beige paint. Refrigeration circuits are leak-tested and dehydrated prior to introduction of refrigerant. CGWR and CCAR units are

then fully charged with compressor oil and refrigerant, and run tested prior to shipment.

- CGWR units are shipped with full operating charge of compressor oil and refrigerant.
- CCAR units are shipped with a nominal charge of compressor oil and a holding charge of dry nitrogen. CCAR units are to be field piped to condenser, dehydrated and charged with refrigerant by others. Note that compressor oil charge may have to be adjusted. See *Pairing Trane CCAR Compressor Chillers (20 to 75 tons) with Trane CAUJ Air-Cooled Condensers (20 to 80 tons) Application Guide (SS-APG014*-EN)* for application guidelines.



Electrical Data

Table 3. Electrical data — CGWR water cooled chillers and CCAR compressor chillers

Unit Size	Compressors						Unit Wiring Data		
	Rated Voltage	Quantity	Number of Refrigerant Circuits	Nominal Tons	RLA (each)	LRA (each)	Minimum Circuit Ampacity	Maximum Fuse Size	Recommended Dual Element Fuse Size
20	208-230/60/3	2	1	10/10	39/39	267/267	88	125	100
	460/60/3				19/19	142/142	42	60	50
	575/60/3				15/15	103/103	35	50	40
30	208-230/60/3	2	1	15/15	48/48	351/351	108	150	125
	460/60/3				25/25	197/197	56	80	60
	575/60/3				22/22	135/135	50	70	60
40	208-230/60/3	3	2	10/10, 20	39/39, 67	267/267, 485	162	225	175
	460/60/3				19/19, 33	142/142, 215	78	110	90
	575/60/3				15/15, 26	103/103, 175	64	80	70
50	208-230/60/3	3	2	12/12, 25	41/41, 82	304/304, 560	185	250	225
	460/60/3				19/19, 40	147/147, 260	88	125	100
	575/60/3				17/17, 29	122/122, 210	69	90	80
65	208-230/60/3	3	2	15/15, 30	48/48, 109	351/351, 717	232	300	250
	460/60/3				25/25, 51	197/197, 320	113	150	125
	575/60/3				22/22, 38	135/135, 235	93	125	110
75	208-230/60/3	3	2	15/15, 40	48/48, 122	351/351, 1010	248	350	300
	460/60/3				25/25, 68	197/197, 344	134	200	150
	575/60/3				22/22, 46	135/135, 327	102	125	110

Notes:

1. Use copper conductors only. Use copper conductors only.
2. Local codes may take precedence.
3. Data containing information on two circuits formatted as follows: Circuit 1, Circuit 2.
4. Voltage Utilization Range: ± 10% of rated voltage. Rated voltage (use range): 208-230/60/3 (187-253), 460/60/3 (414-506), 575/60/3 (518-632).



Dimensions and Weights

Dimensions

The Trane application manual and/or project submittals contain dimensional data, application data, and electrical data as required.

Refer to name plate on control box door (inside) for specific unit electrical data.

These documents can be forwarded for specific jobs as part of a job submittal package upon request.

Figure 1. CGWR/CCAR 20 to 30 ton mechanical drawing

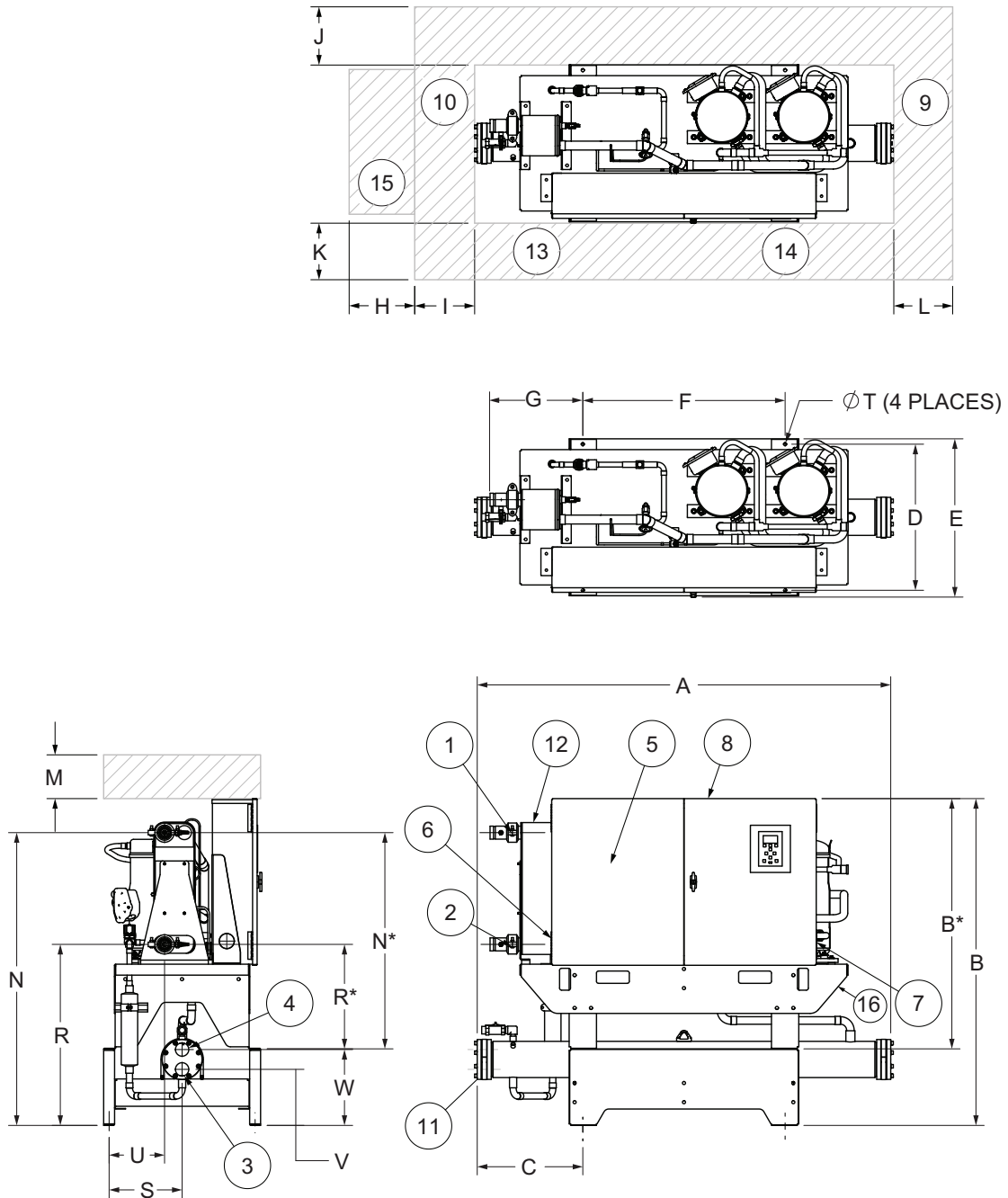


Table 4. CGWR/CCAR 20 to 30 ton — in (mm)

Dimension	CGWR 20	CGWR30	CCAR 20	CCAR 30
A ^(a)	76.6 (1946)	77.5 (1969)	70.4 (1788)	70.4 (1788)
B	59.8 (1519)	59.8 (1519)	45.8 (1163)*	45.8 (1163)*
C	19.3 (490)	20.1 (511)	N/A	N/A
D	26.7 (678)	26.7 (678)	26.7 (678)	26.7 (678)
E	28.9 (734)	28.9 (734)	28.9 (734)	28.9 (734)
F	37.0 (940)	37.0 (940)	37.0 (940)	37.0 (940)
G	17.0 (432)	17.0 (432)	17.0 (432)	17.0 (432)
H	20 (508)	20 (508)	N/A	N/A
I	36 (914)	36 (914)	36 (914)	36 (914)
J ^(b)	36 (914)	36 (914)	36 (914)	36 (914)
K ^(b)	36 (914)	36 (914)	36 (914)	36 (914)
L	24 (610)	24 (610)	24 (610)	24 (610)
M	36 (914)	36 (914)	36 (914)	36 (914)
N	53.5 (1359)	53.5 (1359)	39.5 (1003)*	39.5 (1003)*
R	33.1 (841)	33.1 (841)	19.1 (485)*	19.1 (485)*
S	13.4 (240)	13.4 (240)	N/A	N/A
T	0.6 (15)	0.6 (15)	0.6 (15)	0.6 (15)
U	10.2 (259)	10.2 (259)	10.2 (259)	10.2 (259)
V	10.3 (262)	10.4 (264)	N/A	N/A
W	13.9 (353)	15.3 (389)	N/A	N/A
1	2 (51) VIC	2.5 (64) VIC	2 (51) VIC	2.5 (64) VIC
2	2 (51) VIC	2.5 (64) VIC	2 (51) VIC	2.5 (64) VIC
3	2 (51) FPT	2.5 (64) FPT	N/A	N/A
4	2 (51) FPT	2.5 (64) FPT	N/A	N/A

Reference	Description	Reference	Description
1	Evaporator Water Inlet	9	Condenser Return Waterbox End (CGWR only)- minimum clearance (for maintenance)
2	Evaporator Water Outlet	10	Condenser Inlet/Outlet End (CGWR only) - minimum clearance (for maintenance)
3	Condenser Water Inlet (CGWR only)	11	Condenser (CGWR only)
4	Condenser Water Outlet (CGWR only)	12	Evaporator
5	Power Disconnect (Optional)	13	Panel Power Section — door swing 24 in (610 mm)
6	Power Wire Entry	14	Panel Control Section — door swing 24 in (610 mm)
7	Control Wire Entry	15	Additional minimum clearance needed for units with water regulating valve option
8	Control Panel	16	Location of CCAR refrigerant line connections, 7/8 in liquid line and 1-3/8 in discharge lines

(a) For CGWR020 and 030: If water regulating valve option is ordered, the overall length is 90.9 in and 93.1 in, respectively.

(b) Exceptions:

1. A minimum clearance of 42 in (1067mm) is required to other electrically grounded parts.
2. A minimum clearance of 48 in (1220mm) is required between two units opposite each other (front-to-front or back-to-back) or to other electrically live parts. See Section 110.26 of National Electrical code (NEC).

Figure 2. CGWR/CCAR 40 to 75 ton mechanical drawing

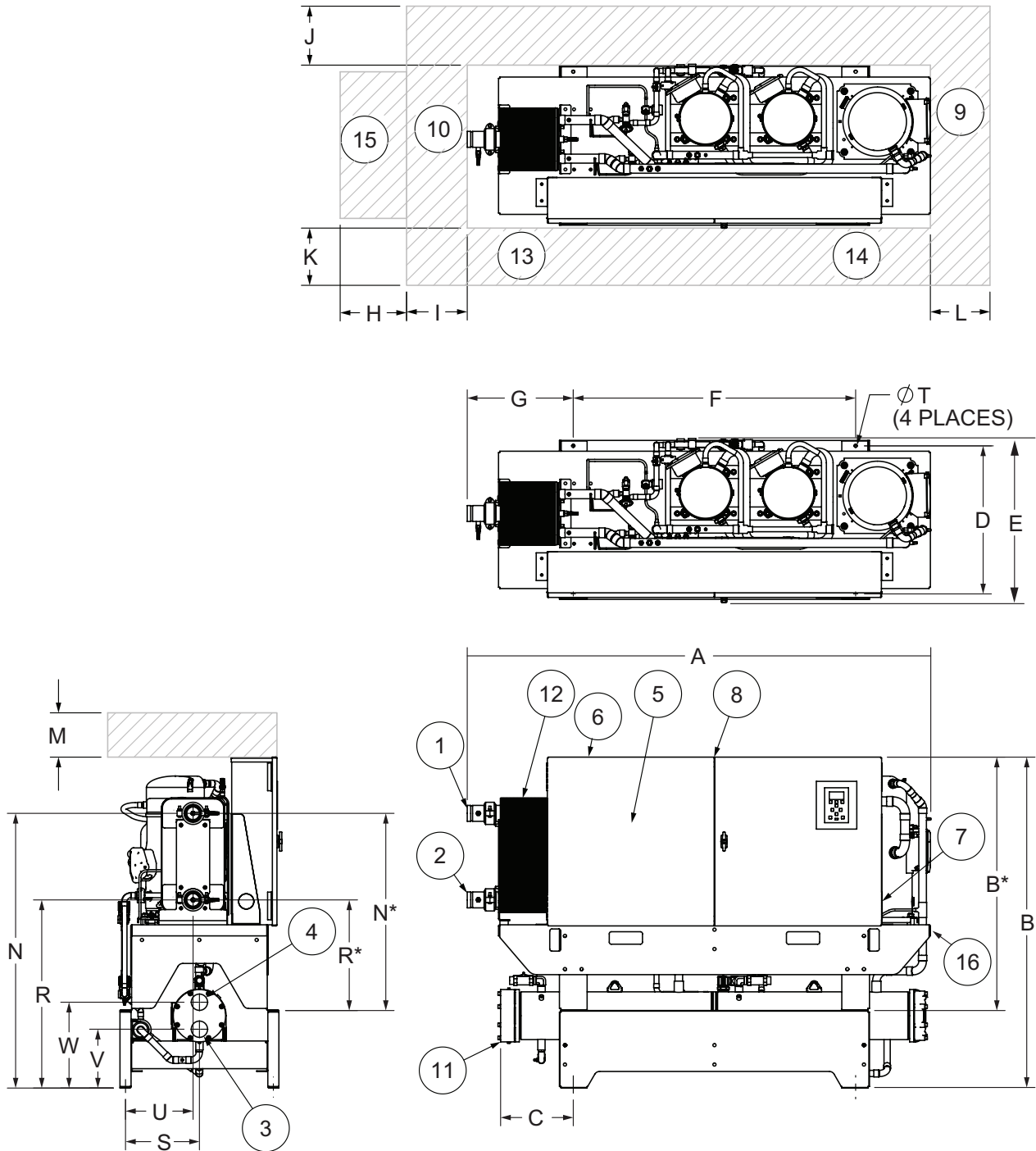


Table 5. CGWR/CCAR 40 to 75 ton — in (mm)

Dimension	CGWR 40	CGWR 50	CGWR 65	CGWR 75	CCAR 40	CCAR 50	CCAR 65	CCAR 75
A ^(a)	83.8 (2128)	83.8 (2128)	83.8 (2128)	83.8 (2128)	87.6 (2225)	87.6 (2225)	87.6 (2225)	87.6 (2225)
B	59.8 (1519)	59.8 (1519)	59.8 (1519)	59.8 (1519)	45.8 (1163)*	45.8 (1163)*	45.8 (1163)*	45.8 (1163)*
C	13.1 (333)	13.6 (345)	13.6 (345)	13.6 (345)	N/A	N/A	N/A	N/A
D	26.7 (678)	26.7 (678)	26.7 (678)	26.7 (678)	26.7 (678)	26.7 (678)	26.7 (678)	26.7 (678)
E	29.6 (752)	29.9 (759)	29.9 (759)	29.9 (759)	29.0 (737)	29.0 (737)	29.0 (737)	29.0 (737)
F	51.0 (1295)	51.0 (1295)	51.0 (1295)	51.0 (1295)	51.0 (1295)	51.0 (1295)	51.0 (1295)	51.0 (1295)
G	19.2 (488)	19.2 (488)	19.2 (488)	19.2 (488)	19.2 (488)	19.2 (488)	19.2 (488)	19.2 (488)
H	20 (508)	20 (508)	20 (508)	20 (508)	N/A	N/A	N/A	N/A
I	36 (914)	36 (914)	36 (914)	36 (914)	36 (914)	36 (914)	36 (914)	36 (914)
J ^(b)	36 (914)	36 (914)	36 (914)	36 (914)	36 (914)	36 (914)	36 (914)	36 (914)
K ^(b)	36 (914)	36 (914)	36 (914)	36 (914)	36 (914)	36 (914)	36 (914)	36 (914)
L	24 (610)	24 (610)	24 (610)	24 (610)	24 (610)	24 (610)	24 (610)	24 (610)
M	36 (914)	36 (914)	36 (914)	36 (914)	36 (914)	36 (914)	36 (914)	36 (914)
N	49.6 (1260)	49.6 (1260)	49.6 (1260)	48.3 (1227)	35.6 (904)*	35.6 (904)*	35.6 (904)*	34.3 (871)*
R	34.0 (864)	34.0 (864)	34.0 (864)	33 (838)	20.0 (508)*	20.0 (508)*	20.0 (508)*	19 (483)*
S	13.4 (340)	13.4 (340)	13.4 (340)	13.4 (340)	N/A	N/A	N/A	N/A
T	0.6 (15)	0.6 (15)	0.6 (15)	0.6 (15)	0.6 (15)	0.6 (15)	0.6 (15)	0.6 (15)
U	12.2 (310)	12.2 (310)	12.2 (310)	12.2 (310)	12.2 (310)	12.2 (310)	12.2 (310)	12.2 (310)
V	10.6 (269)	11.0 (279)	11.0 (279)	11.0 (279)	N/A	N/A	N/A	N/A
W	15.5 (394)	16.8 (427)	16.8 (427)	16.8 (427)	N/A	N/A	N/A	N/A
1	3.0 (76) VIC	3.0 (76) VIC	3.0 (76) VIC	2.5 (64) VIC	3.0 (76) VIC	3.0 (76) VIC	3.0 (76) VIC	2.5 (64) VIC
2	3.0 (76) VIC	3.0 (76) VIC	3.0 (76) VIC	2.5 (64) VIC	3.0 (76) VIC	3.0 (76) VIC	3.0 (76) VIC	2.5 (64) VIC
3	2.5 (64) FPT	3.0 (76) FPT	4.0 (102) FPT	4.0 (102) FPT	N/A	N/A	N/A	N/A
4	2.5 (64) FPT	3.0 (76) FPT	4.0 (102) FPT	4.0 (102) FPT	N/A	N/A	N/A	N/A

Reference	Description	Reference	Description
1	Evaporator Water Inlet	9	Condenser Opposite Inlet/Outlet End (CGWR only) — minimum clearance (for maintenance)
2	Evaporator Water Outlet	10	Condenser Inlet/Outlet End (CGWR only) — minimum clearance (for maintenance)
3	Condenser Water Inlet (CGWR only)	11	Condenser (CGWR only)
4	Condenser Water Outlet (CGWR only)	12	Evaporator
5	Power Disconnect (Optional)	13	Panel Power Section — door swing 31.3 in (795 mm)
6	Power Wire Entry	14	Panel Control Section — door swing 31.3 in (795 mm)
7	Control Wire Entry	15	Additional minimum clearance needed for units with water regulating valve option
8	Control Panel	16	Location of CCAR refrigerant line connections, (2) 1-1/8 in liquid line and (2) 1-3/8 in discharge lines

(a) For CGWR040, 050, 065 and 075: If water regulating valve option is ordered, the overall length is 90.8 in, 92.4 in, 93.6 in and 93.6 in respectively.

(b) Exceptions:

1. A minimum clearance of 42 in (1067mm) is required to other electrically grounded parts.

2. A minimum clearance of 48 in (1220mm) is required between two units opposite each other (front-to-front or back-to-back), or to other electrically live parts. See Section 110.26 of National Electrical code (NEC).



Dimensions and Weights

Weights

Table 6. Weights

Unit	Size	Shipping		Operating	
		lbs	kg	lbs	kg
CGWR	20	1475	669	1116	506
	30	1745	792	1252	568
	40	2150	975	1659	753
	50	2336	1060	1847	838
	65	2554	1158	2039	925
	75	2888	1310	2326	1055
CCAR	20	1077	489	846	384
	30	1205	547	909	412
	40	1626	738	1265	574
	50	1778	806	1304	591
	65	1898	861	1484	673
	75	2187	992	1672	758



Installation

General Installation Information

- Where specified, supply and install valves in the water piping upstream and downstream of the evaporator and condenser, to isolate the heat exchangers for maintenance and to balance/trim the system.
- Supply and install condenser water control valve. Refer also to Trane publication *Condenser Water Temperature Control Engineering Bulletin* (RLC-PRB021*-EN) available from Trane Sales Offices for additional technical assistance. Provisions must be made for the control of condenser water that results in stable Saturated Discharge Pressure between 75°F and 145°F through all steady state, part load and transient operating conditions. Trane recommends optional factory installed integral Water Regulating Valve operated by on-board controller.
- Optional Water Regulating Valve — Trane offers a fully installed and integrated water regulating valve designed to stabilize discharge pressure at all full and part load conditions. Factory installed water regulating valve is controlled by the chillers unit controller and is available on all models.
- Supply and install an approved flow switch, or suitable flow proving device, in the chilled water line as shown in [Figure 3, p. 22](#). Flow switch must be interlocked with chillers unit controller to ensure the unit cannot operate when chilled water flow through the unit is below the minimum chilled water flow limit. See field-wiring diagram for flow proving device connection points. A factory approved flow switch may be ordered with the unit as a shipped-loose option, for field installation by others.
- Supply and install drain vent points with valves on both chilled and condenser water line to vent air and drain lines and equipment for service.
- Install a wye strainer ahead of all system pumps and control valves.

Note: *A wye strainer with twenty mesh screen must be installed in the chilled water pipe immediately adjacent to the evaporator inlet. See [Figure 3, p. 22](#). A factory approved wye strainer may be ordered with the unit as a shipped-loose option, for field installation by others.*

- Supply and install suitable refrigerant pressure relief piping from the pressure relief to the atmosphere if required. Follow ANSI/ASHRAE 15-2007 guidelines, relief manufacturers guidelines, and industry standards when working with relief piping.
- If necessary, supply enough refrigerant and dry nitrogen (150 psig) for pressure testing (CCAR).
- Start the unit under supervision of a qualified service technician.
- Where specified, supply and insulate the chilled water piping as required, to prevent sweating under normal operating conditions. Trane provides factory insulation on evaporator and related components.

Storage

NOTICE

Store Units Above Freezing!

Store these units in a protected area above freezing (32°F) only. Do not store outdoors with a protective covering such as a plastic shroud. This can result in excessive water condensation that could damage controls and other components.

These units are designed for indoor installation above freezing (32°F) only. Store the unit in a suitable weatherproof location above 32°F, vibration free, and secure area. Periodically check the pressure in each refrigerant circuit to verify that the refrigerant charge is intact. If it is not, contact a qualified service organization and the appropriate sales office. If the unit is still under factory warranty, you must follow warranty procedure prior to calling for service.

Noise Considerations

Locate the unit away from sound-sensitive areas. If necessary, install the optional isolators under the unit and/or the optional factory sound attenuation compressor blankets or attenuation cabinet. Install vibration isolators in all piping and use flexible electrical conduit. Consult an acoustical engineer for critical applications.

Foundation

A base or foundation is recommended for most installations. Provide a level surface strong enough to support the unit. Refer to "[Dimensions and Weights](#)," [p. 12](#) for dimensions and weights. A flexible (isolated) concrete foundation or footings at each loading point will reduce transmission of vibration. Install anchor bolts in the concrete to secure the unit. If the floor is warped, uneven or in poor condition, make necessary repairs before positioning the unit. Once the unit is in place, it should be level, within 1/4 inch over its entire length and width.

Clearances

Provide enough space around the unit to allow the installation and maintenance personnel unrestricted access to all service points. Unit dimensions are given in "[Dimensions and Weights](#)," [p. 12](#). There should be adequate clearance for condenser and compressor servicing. A minimum of three feet is recommended for effective compressor service. A minimum clearance of 3 ft.-6 inches is required to open the control panel doors.

A minimum clearance of 42 in (2067 mm) is required to other electrically grounded parts. A minimum clearance of 48 in (1220 mm) is required between two units opposite each other (front-to-front or back-to-back) or to other electrically live parts. See Section 110.26 of National Electrical Code (NEC).



Installation

Important: In all cases, local codes will take precedence over these recommendations.

Ventilation

Provisions must be made to remove heat generated by unit operation from the equipment room. Ventilation must be adequate to maintain an ambient temperature lower than 125°F.

The condenser relief valve on these units must be vented in accordance with all local and national codes.

Drainage

Locate the unit near a large capacity drain for condenser drain-down during shutdown or repair.

Handling

⚠ WARNING

Heavy Objects!

Failure to follow instructions below could result in unit dropping which could result in death or serious injury, and equipment or property-only damage.

Ensure that all the lifting equipment used is properly rated for the weight of the unit being lifted. Each of the cables (chains or slings), hooks, and shackles used to lift the unit must be capable of supporting the entire weight of the unit. Lifting cables (chains or slings) may not be of the same length. Adjust as necessary for even unit lift.

CCAR and CGWR units are shipped stretch-wrapped and bolted to a shipping skid (unless other than standard shipping is selected).

The skidded unit can be moved by using a fork truck of suitable capacity. Refer to "Dimensions and Weights," p. 12 for unit weights.

When moving the unit, the lifting forks must be positioned under the shipping skid as wide as possible where labeled. Lift the unit and move it to the desired location.

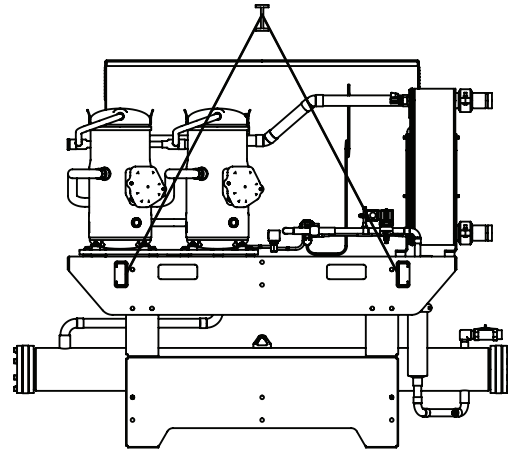
Once the unit is at the installation location, remove the stretch wrap. Inspect the unit for damage and report if damage is found.

The optional unit isolators (if ordered) are secured to the shipping skid or in the unit control panel. Other optional ship loose items may be attached to the skid or shipped separately depending on options selected.

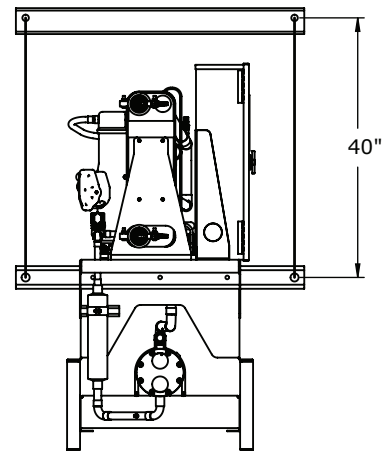
Rigging/Lifting Procedure

If the CGWR/CCAR is not moved using a forklift and the forklift pockets provided as part of the chillers frame, then the chiller should be lifted and moved by using the lifting rails as outlined in [Step 1](#) through [Step 8](#).

Install the lifting rails and lift as shown below:



BACK VIEW



LEFT END VIEW

⚠ WARNING

Heavy Objects!

Failure to follow instructions below could result in unit dropping which could result in death or serious injury, and equipment or property-only damage.

Ensure that all the lifting equipment used is properly rated for the weight of the unit being lifted. Each of the cables (chains or slings), hooks, and shackles used to lift the unit must be capable of supporting the entire weight of the unit. Lifting cables (chains or slings) may not be of the same length. Adjust as necessary for even unit lift.

1. Remove the stretch wrap from the unit as described in the "Handling," p. 18, leaving the unit mounted to the skid.
2. Insert the lifting rails as shown in the preceding figure. Secure the lifting rails to the unit frame by torquing the 1/2-inch bolts to 70 ft-lbs.
3. Install clevis connectors or equivalent in the 1-1/4-inch lifting holes provided at each end of the lifting rails.

4. Attach certified lifting chains (cables) to these points. Each chain (cable) alone must be strong enough to lift the unit.
5. Attach chains (or cables) to a lifting beam. Position the chains (cables) so that they do not contact the unit piping or the unit control panel. Use a suitable spreader bar to insure proper weight distribution.

NOTICE

Equipment Damage!

To prevent damage to the unit, position the lifting beam and chains (cables) so that they do not contact the unit piping or the unit control panel.

6. Remove the bolts that secure the unit to the shipping skid.
7. Raise the unit just off the skid to make sure that the unit is level when lifted. Adjust chain (cable) lengths as required for level lifting.
8. Lift the unit off of the skid and place in the installation location.

Access Restrictions

All CCAR/CGWR units are designed to pass through a standard 36-inch doorway. Refer to outline drawings for other important dimensions.

Trane does not recommend disassembling a CGWR/CCAR to gain access through challenging rigging paths and installation locations. If disassembly/reassembly of a chiller does take place, please note the following:

1. A qualified Trane technician must perform the task
2. Use technical support for any questions that may arise during the task
3. Be aware that disassembly/reassembly could possibly affect warranty status of the chiller, especially if failure/issues occur that point toward improper reassembly and installation
4. All required installation and start-up checklists are still required to be completed and promptly returned for review, including the required running data log as instructed in the start-up checklist

Direct Mounting

The unit can be installed directly on an isolated, rigid mounting surface as long as the surface is level and will support the weight of the unit. A mounting hole is provided at each of the unit mounting locations. Provide a means of securely anchoring the unit to the mounting surface. Level the unit carefully.

Neoprene Isolator Pad Mounting (Optional)

The optional neoprene isolator pads are to be placed between the direct mounting surface and each of the chillers mounting locations. To help distribute the chiller's load to the neoprene pads, place the 6 in. x 6 in. mounting plates between each pad and the chiller. Provide a means of securely anchoring the chiller to the mounting surface.

Level the unit carefully as instructed in "Unit Leveling," p. 19.

Compressor Mounting

All compressors are rigidly bolted with compressor isolation mounts to compressor mounting rails (tandem compressor sets) or directly to the unit base. No additional isolation or leveling is required. Inspect prior to start up to insure bolts are present and tight, and that no shipping damage has occurred.

Unit Leveling

Before tightening the mounting bolts, level the unit front-to-back and end-to-end. Unit must be level within 1/4 inch from front-to-back and within 1/4 inch over the length of the unit. The units base deck can be used for leveling. Use shims as required to properly level unit base.

Compressor Nameplate

The nameplate for the hermetic scroll compressor is mounted on the compressor housing, near the motor terminal junction box.

Evaporator Nameplate

The evaporator nameplate is mounted on evaporator under the insulation. To view the evaporator nameplate, remove the insulation over the area if covered and spread the insulation. The serial number information is also on record at the factory.

Condenser Nameplate

The condenser ASME nameplate is mounted on the side of the condenser.



Unit Piping

Water Piping — General

Make water piping connections to the evaporator and condenser (CGWR only). Isolate and support piping to prevent stress on the unit. Use unions, flanges or grooved lock type fittings to simplify disassembly and facilitate service procedures. Use vibration eliminators to prevent transmitting vibrations to the water lines. Install thermometers in the lines to monitor evaporator and condenser water temperatures. Install balancing cocks in both the leaving chilled water and condenser water lines. These valves can be used to establish a balanced water flow. Entering and leaving chilled and condenser water lines should have shutoff valves installed to isolate the heat exchanger for service. See [Figure 3, p. 22](#) for chilled water piping schematic and [Figure 4, p. 23](#) for condenser water piping schematic.

Do not overtighten connections. Use a pipe sealant such as Teflon® tape on all threaded water connections. Flush all piping before attaching to the unit. Unit **MUST** be bypassed if using a flushing agent.

NOTICE

Equipment Damage!

To prevent equipment damage, you **MUST** follow instructions below:

- **Bypass unit if using a flushing agent.**
- **Chilled water piping must rise above the chiller to insure the evaporator is full of water and void of air at all times.**
- **Do not overtighten connections.**

Piping and specialties must be installed in accordance with national and local codes.

Water Flow Rates

Establish balanced water flow through both the evaporator and condenser. Flow rates should fall between the minimum and maximum values given in General Data [Table 1, p. 8](#) and [Table 2, p. 8](#). Flow rates above or below these values can cause equipment damage or improper unit operation. Measure the evaporator and condenser water pressure drop at the gauge ports located adjacent to the heat exchanger, *before* any piping specialty components, such as wye strainer. Evaporator water pressure drop curves are shown in [Table 5, p. 24](#). Condenser pressure drop curves are shown in [Table 6, p. 24](#).

Optional inlet wye strainer has an outlet port that can be used for measuring inlet evaporator water pressure, *if* it is installed immediately adjacent to the evaporator inlet.

Note: *Evaporator and condenser pressure drop measurement is for an approximation and is to be used as a tool to estimate flow rate and as an aid in waterside system design. If an accurate measurement of flow*

rate is required, an accurate flow measurement device must be installed in the water line.

Water Treatment

NOTICE

Proper Water Treatment Required

The use of untreated or improperly treated water could result in scaling, erosion, corrosion, algae or slime. Use the services of a qualified water treatment specialist to determine what water treatment, if any, is required. Trane assumes no responsibility for equipment failures which result from untreated or improperly treated water, or saline or brackish water.

Using untreated or improperly treated water in these units may result in inefficient operation and possible tube and/or brazed plate damage. Consult a qualified water treatment specialist to determine if treatment is needed.

NOTICE

Water Borne Debris!

To prevent components damage, pipe strainers must be installed in the water supplies to protect components from water borne debris. Trane is not responsible for equipment-only-damage caused by water borne debris.

Chilled Water Piping

Chilled water piping and associated components shall be installed in accordance with [Figure 3, p. 22](#). Chilled water inlet and outlet types, sizes and locations are provided in [Table 4, p. 13](#) and [Table 5, p. 15](#). Chilled water piping must rise above the chiller to ensure the evaporator is full of water and void of air at all times. All chilled water lines must be insulated to minimize heat gain and prevent condensation.

Brazed Plate Evaporator

Trane CGWR/CCAR chillers are equipped with brazed plate evaporators made of stamped stainless steel plates, furnace brazed together with copper to form a durable high efficiency heat exchanger. Because of the small complex geometry of the flow passages, it is imperative customers take all precautions to ensure these evaporators are not fouled by large particles or internal mineral deposits. For this reason, a 20 mesh wye strainer is required in the inlet chilled water line. Operation of the chiller without this wye strainer or the wye strainer 20 mesh screen will void the chiller warranty. Chemical treatment of the chilled water loop is required and must be performed by a qualified water specialist.

NOTICE

Proper Water Treatment Required!!

The use of untreated or improperly treated water could result in scaling, erosion, corrosion, algae or slime. Use the services of a qualified water treatment specialist to determine what water treatment, if any, is required. Trane assumes no responsibility for equipment failures which result from untreated or improperly treated water, or saline or brackish water.

Wye Strainer — Required

A wye strainer with 20 mesh screen must be installed immediately adjacent to the inlet water connection to the evaporator.

Important: Operation of the chiller without this wye strainer AND 20 mesh screen in place will void the unit warranty.

Flow Proving Device — Required

NOTICE

Unexpected Chiller Start!

Failure to follow instructions could cause the chiller to start unexpectedly which could result in equipment or property damage. An external source (EMS, time clock or any other means) should not be allowed to bring on a pump that would trigger the flow switch to start the chiller. The flow switch is meant to act as a safety switch and not a start/stop mechanism.

Optional chilled water flow switch or other factory approved flow proving device is mandatory. It is field-installed by others. Flow switch is to be installed and maintained in accordance with manufacturers recommendations and interconnected to the unit control panel as described in the field-wiring diagram. To provide additional chiller protection, wire the flow proving device control circuit in series with a chilled water pump starter normally open auxiliary contact to create a chilled water pump interlock. See “Chilled Water Flow Switch,” p. 29.

Chilled Water System Volume

Trane requires minimum system volumes as indicated in Table 7, p. 21. Special applications may allow deviation from these volumes, but only with approval of Trane engineering. Operation below these volumes will cause unacceptable system control problems and the potential for evaporator failure.

Table 7. Minimum system volumes

CGWR/CCAR Unit Size (tons)	Minimum System Volume (gal)
20	157
30	226
40	311

Table 7. Minimum system volumes (continued)

CGWR/CCAR Unit Size (tons)	Minimum System Volume (gal)
50	355
65	442
75	513

Condenser Water Piping

Condenser water piping and associated components shall be installed in accordance with condenser water piping schematic Figure 4, p. 23. Condenser water inlet and outlet types, sizes, and locations are provided in Table 4, p. 13 and Table 5, p. 15.

NOTICE

Excessive Water Pressure!

To prevent condenser or regulating valve damage, do not exceed nameplate condenser water pressure.

Discharge Pressure Control/Optional Factory-Installed Water Regulating Valve

A means of maintaining stable discharge pressure during full-load, part-load and transient conditions is required. Saturated discharge temperature must be maintained between 75°F and 145°F. Trane offers an optional factory installed water regulating valve that is controlled by the unit controller. The optional water regulating valve maintains condensing pressure and temperature by throttling water flow leaving the condenser in response to compressor discharge pressure. Field-supplied water regulating valves must be adjusted for proper operation during full-load, part-load and transient conditions. Field-supplied water regulating valves must also be adjusted for proper positioning when unit is off.

Alternative field-supplied methods for condensing pressure/temperature control include the use of cooling tower control strategies. Cooling tower systems may include a manual or automatic bypass valve that can alter water flow rate and basin temperature to maintain stable condensing temperature at the chiller.

Well or city water condensing systems should include a water regulating valve and potentially a pressure reducing valve. A pressure reducing valve should be installed to reduce water pressure entering the condenser if water pressure can exceed tube-side maximum allowable working pressure as indicated on the condenser nameplate. This is also necessary to prevent damage to disc and seat type water regulating valves caused by excessive pressure drops through the valve.

Under full load AHRI standard conditions, and with approximately 3 gpm/ton cooling water flow through the condenser, the temperature rise across the condenser will be approximately 10°F. In all cases, the minimum inlet condenser water temperature is 65°F.

Figure 3. Chilled water piping schematic

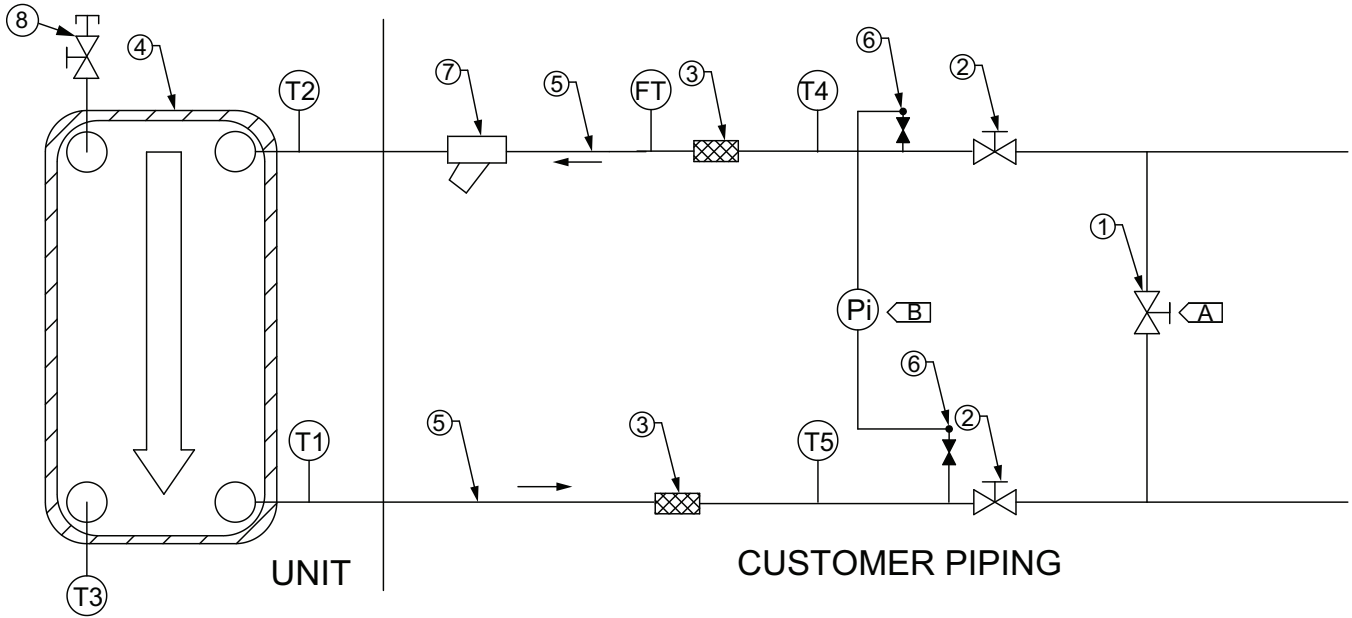


Table 8. Reference numbers

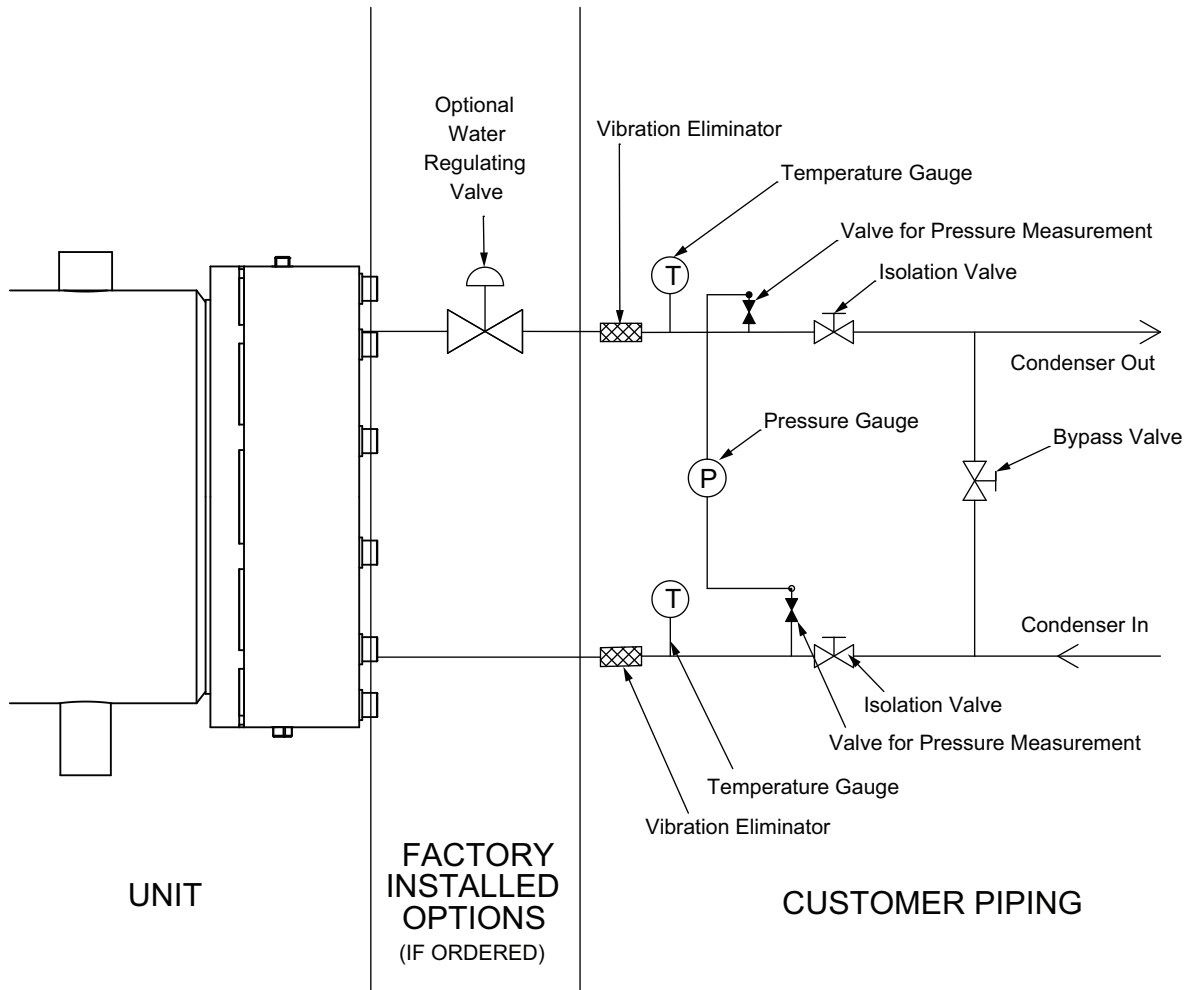
Item	Description
1	Bypass valve
2	Isolation valves
3	Vibration eliminators
4	Evaporator heat exchangers
5	Inlet and outlet chilled water lines
6	Valves for pressure measurement
7 ^(a)	Strainer with 20 mesh screen
8	Evaporator manual air vent valve w/plug
A	Isolator unit for initial water loop cleaning
B ^(b)	Arrangement for measuring differential pressure
FT ^(c)	Water flow switch
Pi	Pressure Gauge
T1	Evaporator outlet temperature sensor
T2	Evaporator inlet temperature sensor
T3	Evaporator core temperature sensor
T4	Chiller inlet temperature gauge
T5	Chiller outlet temperature gauge

(a) Strainer with 20 mesh screen is required.

(b) Must account for water head difference when calculating total unit pressure differential.

(c) Chilled water flow-proving device is required.

Figure 4. Condenser piping schematic





Water Pressure Drop Curves

Figure 5. Evaporator water pressure drop

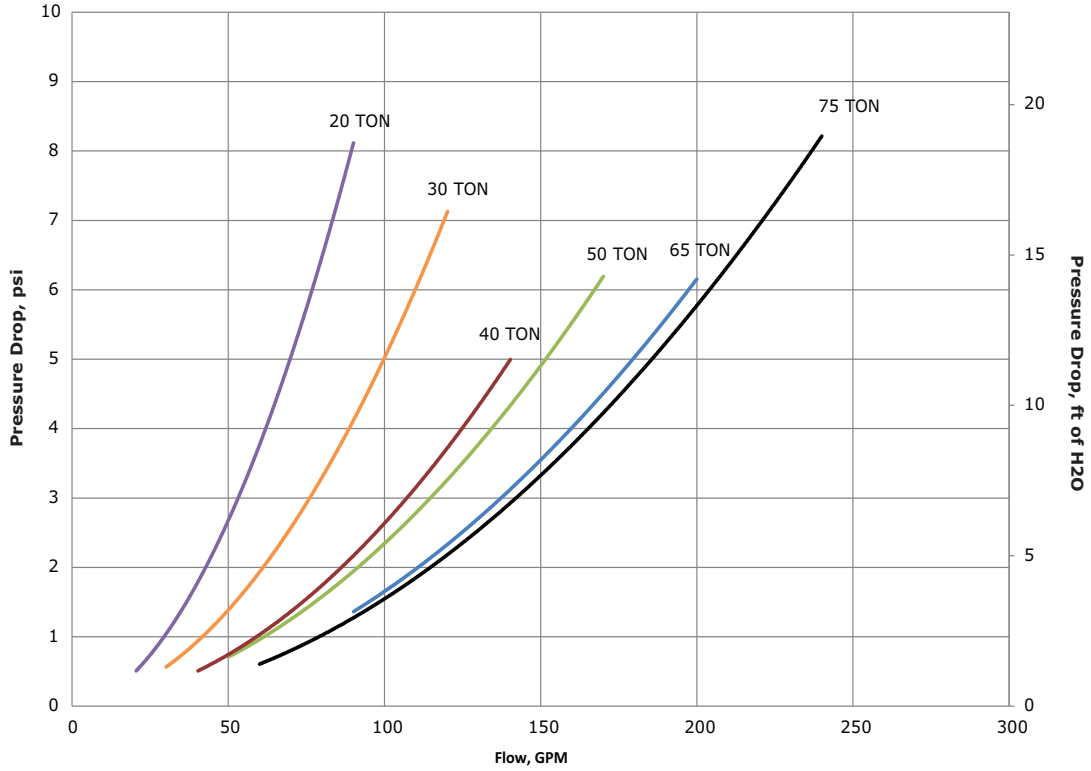
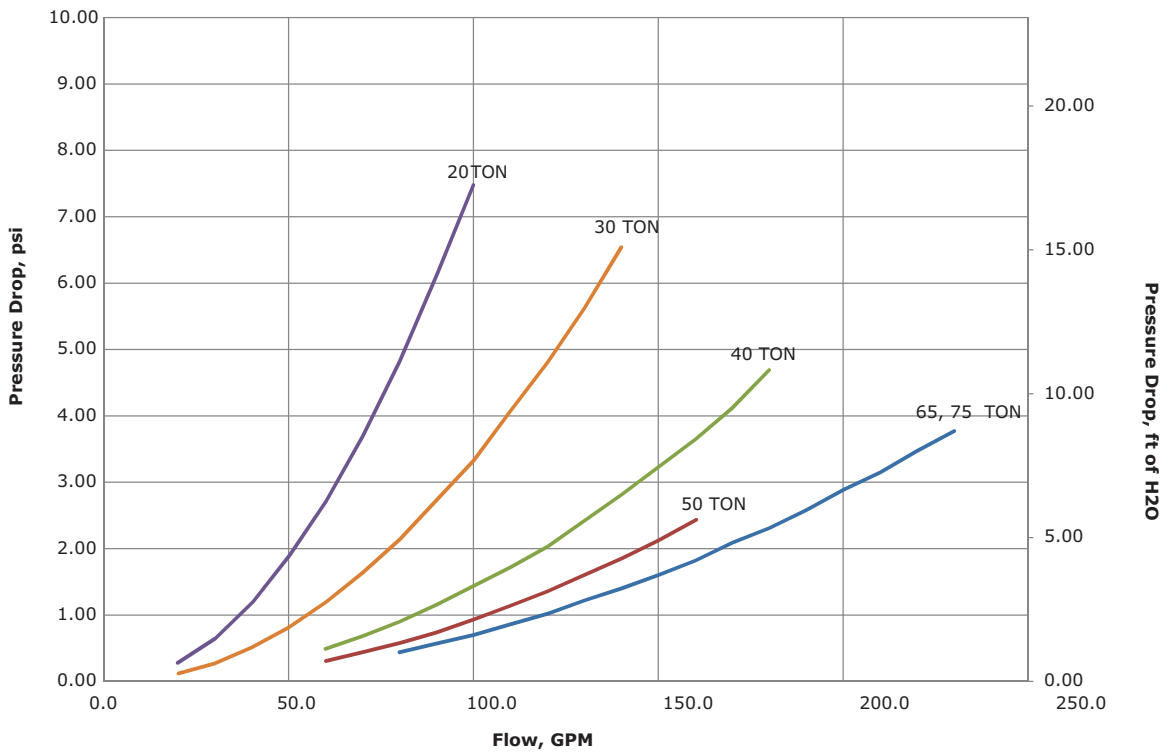


Figure 6. Condenser water pressure drop



Low Suction Temperature and Pressure Cutouts/Percent Glycol Recommendations

Table 9, p. 25 shows the low suction temperature and pressure cutouts for different glycol levels.

Additional glycol beyond the recommendations will adversely affect unit performance. The unit efficiency will be reduced and the saturated evaporator temperature will be reduced.

For some operating conditions this effect can be significant.

If additional glycol is used, then use the actual percent glycol to establish the Low and Unsafe refrigerant suction pressure cutout set points.

Table 9. Minimum recommended setpoints

Ethylene Glycol/Water					Propylene Glycol/Water				
Glycol % (By Mass)	Solution Freeze Point (°F)	LOW SUCTION ^(a) (psig)	UNSAFE SUCT ^(b) (psig)	FREEZE ^{(c)(d)} (°F) CORE FREEZE ^(e) (°F)	Glycol % (By Mass)	Solution Freeze Point (°F)	LOW SUCTION ^(a) (psig)	UNSAFE SUCT ^(b) (psig)	FREEZE ^{(c)(d)} (°F) CORE FREEZE ^(e) (°F)
0	32.0	101.12	71.58	38.0	0	32.0	101.12	71.58	38.0
2	30.9	98.87	69.79	36.9	2	30.9	98.87	69.79	36.9
4	29.9	96.86	68.18	35.9	4	29.7	96.46	67.86	35.7
5	29.4	95.86	67.39	35.4	5	29.1	95.26	66.91	35.1
6	28.8	94.67	66.44	34.8	6	28.5	94.08	65.97	34.5
8	27.5	92.13	64.42	33.5	8	27.3	91.75	64.12	33.3
10	26.2	89.64	62.44	32.2	10	26.1	89.45	62.29	32.1
12	24.6	86.63	60.06	30.6	12	24.8	87.00	60.35	30.8
14	23.0	83.69	57.73	29.0	14	23.6	84.78	58.60	29.6
15	22.2	82.24	56.59	28.2	15	22.9	83.51	57.59	28.9
16	21.3	80.63	55.32	27.3	16	22.1	82.06	56.45	28.1
18	19.6	77.65	52.98	25.6	18	20.7	79.57	54.49	26.7
20	17.9	74.75	50.69	23.9	20	19.2	76.96	52.43	25.2
22	15.9	71.42	48.08	21.9	22	17.5	74.07	50.16	23.5
24	13.7	67.86	45.30	19.7	24	15.6	70.92	47.69	21.6
25	12.7	66.28	44.07	18.7	25	14.6	69.30	46.42	20.6
26	11.4	64.27	42.50	17.4	26	13.7	67.86	45.30	19.7
28	9.2	60.95	39.91	15.2	28	11.5	64.42	42.62	17.5
30	6.7	60.65	39.68	15.0	30	9.2	60.95	39.91	15.2
32	4.2	60.65	39.68	15.0	32	6.6	60.65	39.68	15.0
34	1.4	60.65	39.68	15.0	34	3.9	60.65	39.68	15.0
35	-0.2	60.65	39.68	15.0	35	2.5	60.65	39.68	15.0
36	-1.5	60.65	39.68	15.0	36	0.8	60.65	39.68	15.0
38	-4.6	60.65	39.68	15.0	38	-2.5	60.65	39.68	15.0
40	-8.1	60.65	39.68	15.0	40	-6.0	60.65	39.68	15.0
42	-11.7	60.65	39.68	15.0	42	-9.8	60.65	39.68	15.0
44	-15.5	60.65	39.68	15.0	44	-14.0	60.65	39.68	15.0
45	-17.6	60.65	39.68	15.0	45	-16.1	60.65	39.68	15.0
46	-19.7	60.65	39.68	15.0	46	-18.3	60.65	39.68	15.0
48	-24.0	60.65	39.68	15.0	48	-23.1	60.65	39.68	15.0
50	-28.9	60.65	39.68	15.0	50	-28.3	60.65	39.68	15.0

(a) LOW SUCTION refers to the low suction pressure cutout.

(b) UNSAFE SUCT refers to the unsafe suction pressure cutout.

(c) FREEZE refers to the low leaving fluid temperature cutout.

(d) The minimum leaving fluid temperature set point, CW OUT TRGT, should not be less than 5°F above the low fluid temperature cutout, FREEZE, and the core fluid temperature cutout, CORE FREEZE.

(e) CORE FREEZE refers to the evaporator core fluid temperature cutout.



Refrigerant Piping (CCAR only)

Note: *If using a Trane CAUJ air-cooled condenser with a Trane CCAR compressor chiller, please refer to the Pairing Trane CCAR Compressor Chillers (20 to 75 tons) with Trane CAUJ Air-Cooled Condensers (20 to 80 tons) Application Guide (SS-APG014*-EN). This guide provides line sizing, field-component selection, application considerations and more. If not using a Trane CAUJ air-cooled condenser, please consider the following general guidelines and recommendations when designing your split system.*

Refer to the industry standards for refrigerant piping selection information; contact the factory if you do not have access to this data. Refrigerant pipe size selected must be within the velocity and pressure drop limitations required for proper system operation. It is essential that refrigerant piping be properly sized and applied since these factors have a significant effect on performance.

Note: *Use Type K refrigerant-grade copper tubing only. The use of a lower grade tubing can cause operating problems.*

General Guidelines

Keep these general guidelines in mind as you review the recommendations specific to field piping refrigerant lines:

- Limit overall line length. Enough sub-cooling may be lost as refrigerant travels up the liquid riser to cause flashing. Review any questionable applications with the factory.
- Pipe sizing software such as Trane Engineering Toolbox can help to quickly determine proper sizes for refrigerant lines based on current engineering data.

Liquid Line

Sufficient sub-cooling must be maintained at the expansion valve. To provide proper operation throughout the range of operating conditions, the liquid-line pressure drop should not exceed the units minimum sub-cooling value less 5°F. To achieve this objective, keep these liquid-line considerations in mind:

1. Select the smallest, practical line size for the application. Limiting the refrigerant charge improves compressor reliability.
2. When designing the liquid line for a typical air-conditioning application (i.e., one with an operating range of 40°F to 110°F), remember that every 10 feet of vertical rise will reduce sub-cooling by 2.8°F, while every 10 feet of vertical drop will add 1.1°F of sub-cooling.
3. Provide a 1-inch pitch toward the evaporator for every 10 feet of run.
4. If the liquid line must be routed through an area warmer than outdoor air temperature, insulate the line to prevent the refrigerant from flashing.
5. A replaceable core liquid line filter drier must be installed as close as possible to the compressor chiller. The core

should be changed whenever the system is opened for service. Trane compressor chillers do not include a filter-drier as standard, but one may be ordered if the installing contractor desires a factory type.

6. A moisture-indicating sight glass permits a visual check of the liquid column for bubbles. Sight glasses are included on the Trane compressor-chiller. However, never use the sight glass to determine whether the system is properly charged! Instead, either charge the system based on the required sub-cooling or calculate the amount of refrigerant needed and add it based on weight.

Discharge (Hot Gas) Line

Limit the pressure drop in the discharge line to 6 psid whenever possible to minimize the adverse effect on unit capacity and efficiency. While a pressure drop of as much as 10 psid is usually permissible, note that a 6-psid pressure drop reduces unit capacity by 0.9 percent and efficiency by 3 percent.

Pitch discharge lines in the direction of hot gas flow at the rate of 1/2-inch per each 10 feet of horizontal run. Discharge line sizing is based on required velocity to provide good oil movement. Basic discharge line parameters are:

- Max allowable pressure drop 6 psig (1F)
- Maximum Velocity 3500 fpm
- Minimum Velocity (at minimum load)
 - Horizontal lines 500 fpm
 - Vertical lines (up flow) 1000 fpm

To design the discharge line properly, follow the recommended guidelines:

- Choose the shortest route from the compressor to the condenser.
- Use different pipe sizes for horizontal and vertical lines to make it easier to match line pressure drop and refrigerant velocity to discharge-line requirements.
- To assure proper oil entrainment and avoid annoying sound levels, size the discharge line so refrigerant velocity equals or exceeds the minimum velocity in [Table 10, p. 27](#) and remains below 3,500 fpm.
- Prevent oil and condensed refrigerant from flowing back into the compressor during off cycles by:
 - a. Pitching the discharge line toward the condenser, and
 - b. Routing the discharge line so that it rises to the top of the condenser, then drops to the level of the condenser inlet, creating an inverted trap.
- Double risers are generally unnecessary. The scroll compressors in Trane units unload to the extent that a single, properly sized riser can transport oil at any load condition.

Table 10. Minimum discharge-line velocities for oil entrainment

Nom. Pipe Size, in.	Riser	Refrigerant Velocity, fpm	
		Horizontal	
7/8	375	285	
1-1/8	430	325	
1-3/8	480	360	
1-5/8	520	390	
2-1/8	600	450	

- Riser traps are also unnecessary. Avoid using riser traps. If the discharge riser is sized to maintain the proper refrigerant velocity, adding a trap will only increase the pressure drop.

Reliability determines the success of a split air-conditioning system. Interconnecting refrigerant lines play an instrumental role in that success. It is up to us to ensure that our system design practices evolve with equipment technologies.

This can be summarized as five fundamental rules:

1. Choose the right system (i.e., do not specify split-system equipment when a packaged chiller is best suited for the job).
2. Size the interconnecting lines to avoid the use of traps and double risers.
3. Slope the liquid lines toward the evaporator.
4. Minimize the length of the interconnecting tubing.
5. Keep the system clean.

Initial Leak Test

As shipped, Trane compressor-chillers contain a holding charge of nitrogen only. Before connecting refrigerant piping, momentarily crack open a Schraeder valve on the liquid line to insure that the unit is still pressurized. If no gas escapes thru the valve, leak test the unit to determine the source of the refrigerant leak prior to installation and repair any leaks located.

Refrigerant Piping Sizes

Refer to the Trane guide *Air Conditioning Clinic* (TRG-TRC006-EN) and/or ASHRAE publications to determine piping selection information. Refrigerant pipe sizes selected must be within the velocity and pressure drop limitations required for proper system operations. It is essential that refrigerant piping be properly sized and applied since these factors have a significant effect on system performance and reliability.

Final Leak Test

⚠ WARNING

Explosion Hazard!

Failure to follow these instructions could result in death or serious injury or equipment or property-only damage.

Use only dry nitrogen with a pressure regulator for pressurizing unit. Do not use acetylene, oxygen or compressed air or mixtures containing them for pressure testing. Do not use hydrogen mixtures containing refrigerant and air above atmospheric pressure for pressure testing as they may become flammable and could result in an explosion.

Refrigerant, when used as a trace gas should only be mixed with dry nitrogen for pressurizing units.

Once refrigerant piping is completed, thoroughly test the system for leaks.

System Evacuation

⚠ WARNING

Risk of Internal Arc Flash!

Failure to follow instructions could result in death, serious injury and compressor damage.

Do not use a megohmmeter or apply power to compressor windings under vacuum as it could result in an arc flash inside the compressor.

For field evacuation after leak checking, use a vacuum pump capable of pulling a vacuum of 100 microns or less. Follow the pump manufacturers instructions for proper use of the pump. Insure that all sections of the system are properly evacuated before proceeding.

Refrigerant Charging

NOTICE

Equipment Damage!

To prevent damage to the evaporator and condenser, never charge liquid refrigerant into either of these vessels without adequate flow to prevent the temperature/pressure relationship to fall below 35°F.

Once the system is properly installed, leak tested and evacuated, refrigerant charging can begin. Liquid refrigerant must be charged into each circuit through the liquid line access with the compressor(s) off.

Charge refrigerant into the system by weight. Use an accurate scale or charging cylinder to determine the exact charge entering the system. Failure to charge the system accurately can lead to under or over-charging and result in unreliable operation.

If system pressure equalize before the full charge enters the system, close the charging port and proceed to start-up procedure.



Electrical Wiring

⚠ WARNING

Proper Field Wiring and Grounding Required!

Failure to follow code could result in death or serious injury.

All field wiring **MUST** be performed by qualified personnel. Improperly installed and grounded field wiring poses **FIRE** and **ELECTROCUTION** hazards. To avoid these hazards, you **MUST** follow requirements for field wiring installation and grounding as described in **NEC** and your local/state/national electrical codes.

General Recommendations

⚠ WARNING

Hazardous Service Procedures!

Failure to follow all precautions in this manual and on the tags, stickers, and labels could result in death or serious injury.

Technicians, in order to protect themselves from potential electrical, mechanical, and chemical hazards, **MUST** follow precautions in this manual and on the tags, stickers, and labels, as well as the following instructions: Unless specified otherwise, disconnect all electrical power including remote disconnect and discharge all energy storing devices such as capacitors before servicing. Follow proper lockout/tagout procedures to ensure the power can not be inadvertently energized. When necessary to work with live electrical components, have a qualified licensed electrician or other individual who has been trained in handling live electrical components perform these tasks.

NOTICE

Use Copper Conductors Only!

Failure to use copper conductors could result in equipment damage as the equipment was not designed or qualified to accept other types of conductors.

The wiring procedures, as described in this portion of the manual, must be accomplished to obtain proper operation of the unit.

All wiring must comply with National Electrical Code (NEC) and state and local requirements. Outside the United States, the national and/or local electrical requirements of other countries shall apply. The installer must provide properly sized system interconnecting and power supply wiring with appropriate fused disconnect switches. Type and locations of disconnects must comply with all applicable codes.

Minimum circuit ampacities, recommended fuse sizes and other unit electrical data are provided on the unit nameplate.

Power and Control Wiring

Unit Power Wiring

The installing contractor must connect appropriate power wiring (with fused disconnects) to the terminal block or non-fused, unit-mounted disconnect in the power section of the unit control panel. Electrical schematics and component location drawings are also mounted on the inside of the control panel door.

The unit power fused disconnect switch should be located in the general area of the unit, to comply with NEC or local codes. Some codes require line-of-sight disconnect locations. The optional unit unfused disconnect can be used as an emergency shutdown device.

Scroll Compressor Electrical Phasing

General

⚠ WARNING

Hazardous Voltage!

Failure to disconnect power before servicing could result in death or serious injury.

Disconnect all electric power, including remote disconnects before servicing. Follow proper lockout/tagout procedures to ensure the power can not be inadvertently energized. Verify that no power is present with a voltmeter.

NOTICE

Compressor Damage!

Operating compressors in reverse rotation will cause damage or failure of the compressor.

It is critical that proper rotation of the scroll compressors be established before the machine is started. Proper motor rotation requires confirmation of the electrical phase sequence of the power supply. The motor is internally connected for clockwise rotation with the inlet power supply phased ABC or L1, L2, L3.

The order in which the three voltages of a three-phase system succeed one another is called phase sequence or phase rotation. When rotation is clockwise, phase sequence is usually called ABC and when counterclockwise, CBA.

This direction may be reversed by interchanging any two of the line wires. It is this possible interchange of wiring that makes a phase sequence indicator necessary, if the operator is to quickly determine the phase rotation of the motor.

Setting Proper Electrical Phase Sequence

Proper compressor motor electrical phasing can be quickly determined and, if necessary, corrected before starting the unit. Use a quality instrument, such as an Associated

Research Model 45 Phase Sequence indicator or equivalent and follow this procedure.

1. Verify that all operating controls for the unit are in the Off position.
2. Disconnect power to the power distribution block in the unit control panel
3. Connect the phase sequence indicator leads to the power distribution block as follows:

Phase Seq. Lead	Terminal ID
Black (Phase A)	L1
Red (Phase B)	L2
Yellow (Phase C)	L3

4. Turn power on by closing the unit supply power fused disconnect switch.
5. Read the phase sequence displayed on the indicator. The ABC LED on the face of the phase indicator will glow if phase sequence is ABC.
6. If the CBA indicator glows instead, open the unit main power disconnect and switch two line leads on the power distribution block in the unit control panel. Close the main power disconnect and recheck phasing.
7. Open the unit disconnect and remove the phase indicator.

Unit Voltage

Electrical power to the unit must meet stringent requirements for the unit to operate properly. Total voltage supply and voltage imbalance between phases should be within the tolerances discussed below.

Voltage Supply

⚠ WARNING

Live Electrical Components!

Failure to follow all electrical safety precautions when exposed to live electrical components could result in death or serious injury.

When it is necessary to work with live electrical components, have a qualified licensed electrician or other individual who has been properly trained in handling live electrical components perform these tasks.

Measure each leg of supply voltage at the line voltage disconnect switches. Readings must fall within the range of 187 to 254 volts for units with a nameplate voltage of 208/230 volt and 414 to 508 volts for units with a nameplate voltage of 460 volts. If voltage on any leg does not fall within tolerance, notify the power company and request correction of this situation before operating the unit. Inadequate voltage to the unit will shorten the life of relay contacts and compressor motors.

Voltage Imbalance

Excessive voltage imbalance between phases in a three-phase system will cause motors to overheat and eventually fail. Maximum allowable imbalance is 2 percent. Voltage imbalance is defined as 100 times the maximum deviation of the three voltages (three phases) subtracted from the average (without regard to sign), divided by the average voltage.

Example:

If the three voltages measured at the line voltage fused disconnect are 221 volts, 230 volts and 227 volts, the average would be:

$$\frac{221 + 230 + 227}{3} = 226 \text{ volts}$$

The percentage of imbalance is then:

$$\frac{100 (226 - 221)}{226} = 2.2\%$$

In the preceding example, 221 is used because it is the farthest from the average. The 2.2 percent imbalance that exists exceeds maximum allowable imbalance by 0.2 percent. This much imbalance between phases can equal as much as 20 percent current imbalance with a resulting increase in winding temperature that will decrease compressor motor life.

Control Power Supply

A fused, panel-mounted control power transformer is standard on all units. Replacement fuses are listed on the Fuse Schedule decal located adjacent to the transformer inside the control box.

External Contacts

Chilled Water Flow Switch

The unit controller has an input that accepts a contact closure from a proof-of-flow device such as a flow switch or other factory approved flow proving device. When this input does not prove flow within a fixed time relative to transition from enabled to run modes of the chiller, or if the flow is lost while the chiller is in the running mode of operation, the chiller will be prohibited from running. The installer must provide and install this flow proving device. See also wiring diagrams attached to the inside of the control panel door. Failure to provide this flow proving device voids unit warranty.

NOTICE

Unexpected Chiller Start!

Failure to follow instructions could cause the chiller to start unexpectedly which could result in equipment or property damage. An external source (EMS, time clock or any other means) should not be allowed to bring on a pump that would trigger the flow switch to start the chiller. The flow switch is meant to act as a safety switch and not a start/stop mechanism.



CCAR Condenser Fan Staging or VFD Control

The CCAR compressor chiller unit controller has the ability to control fan staging, fan VFDs and damper control in order to improve the stability of discharge pressure at various ambient conditions.

Unit controller capability single circuit compressor chillers (CCAR 20, and 30) have three dry contact relays to cycle condenser fan motors to control discharge pressure, as well as one 0 to 10 Vdc analog output to control a VFD or fan damper. Dual circuit compressor chillers (CCAR 40, 50, 65 and 75) have six dry contact relays to cycle condenser fan motors to control discharge pressure, as well as two 0 to 10 Vdc analog output to control a VFD or fan damper.

CCAR unit controller must control condenser ambient control devices such as fan cycling and optional low ambient dampers. As a result the interconnecting field wiring must be done by others. For pairing CCAR compressor chiller with CAUJ air cooled condenser, the following field wiring is to be done by others.

- **Fan cycling control**
 - One control wire for each condenser fan plus a common must be run between CCAR compressor chiller and CAUJ condenser.
 - Required fan control wiring for CCAR compressor chillers matched with CAUJ condensers utilizing fan control are covered by schematic, instructions, and associated footnotes on [Figure 21, p. 54](#) and [Figure 22, p. 55](#).
- **Low Ambient Dampers (when applicable)**
 - One shielded pair for each condenser damper assembly must be run between CCAR compressor chiller and CAUJ air cooled condenser.
 - Required damper control wiring for CCAR compressor chillers matched with CAUJ condensers utilizing low ambient control damper assembly are covered by schematic, instructions and associated footnotes on [Figure 23, p. 56](#) and [Figure 24, p. 57](#).

CGWR Condenser Water Loss of Flow Protection

The controller logic will sense a loss of flow through the condenser. No flow switches are necessary with the standard unit controller configuration.

CGWR Condenser Control

CGWR units have one dry contact relay to start a condenser pump. These chillers also have one 0 to 10 Vdc analog output to control a head pressure control valve.

Consult wiring diagram located inside the control box door for connection point(s).

Equipment Grounds

NOTICE

Use Copper Conductors Only!

Failure to use copper conductors could result in equipment damage as the equipment was not designed or qualified to accept other types of conductors.

Provide proper grounding at the connection point provided in the unit control panel.

Unit Controller

Note: *The unit controller section in this IOM contains only a brief overview of the unit controller. Please consult the Unit Controller Version 17 Manual Rev. 3.0 for Cold Generator™ Chillers Installation, Operation, and Maintenance (CG-SVX030*-EN) which documents the function of the unit controller including setpoint definitions, points lists and much more.*

The unit controller is a rugged microprocessor based controller designed for the hostile environment of the HVAC/R industry. It is designed to be the primary manager of the CCAR/CGWR product.

The unit controller provides flexibility with setpoints and control options that can be selected prior to commissioning a system or when the unit is live and functioning. Displays, pressures, temps, alarms and other interfaces are accomplished in a clear and simple language that informs the user as to the status of the controller. Refer also to the wiring diagram attached to the inside of the control panel door.

A password is required to access controller setpoints. Use password code 2112 to access many of these features. A factory code may be required to allow access to critical areas, and can only be entered by a factory representative.

A RS-485 port is provided for communication with other manufacturers systems. Additionally, a built-in RS-485 to RS-232 converter allows communication over the RS-485 port via the RS-232 port. Other features include the integration of BACnet® IP and MODBUS® into the unit controller. An optional gateway card allows communication via BACnet® MSTP, Johnson N2, and LONWORKS®, and this should be ordered with the chiller if required. An ethernet connection is also provided on each unit. While field changes can be made, please insure that the unit is ordered set up for required communications to insure that factory testing includes end user configuration.

A complete software support package is available for your PC allowing for system configuration, dynamic on-line display screens, remote communication, graphing and more. See ["Downloading and Installing Unit Controller \(MCS-Connect\) Software," p. 32](#) for download instructions. All information needed to run the unit is available from the unit display; however, a laptop computer is invaluable for ease of use of diagnosing or changing the unit setpoints.

Note: *Not all setpoints can be changed with MCS-Connect; some require a configuration change.*

For units that have a keypad as a controller interface, a serial cable is included. If you do not have a laptop with a serial port, you will require a converter such as a Black Box item number #IC199A-R3 serial-to-USB adaptor.

The standard configuration allows for unit to start at lowest stage possible, then add compressors as needed to meet demand.

Important: *All configuration changes need to be done by factory representatives to ensure proper operation of the unit within design parameters. Refer to MCS unit controller manual for sequence of operation and additional details.*



Unit Controller — Software Installation and Setup

Downloading and Installing Unit Controller (MCS-Connect) Software

Go to www.nappstech.com. Click on Downloads in the grey bar and select **MCS-CONNECT**. Select **SAVE**. After downloading, open and select **RUN**. Follow prompts and software will be installed on your computer.

If your computer does not have a serial port, you will need to purchase a USB to Serial adapter. (Computer stores should have this.) Install the software for the adapter. If your computer has a serial port, you will not need an adapter.

You will need to know which Port your computer uses as the **COM PORT**. In Microsoft® Vista, go to the **CONTROL PANEL** and select **DEVICE MANAGER**. Look for **PORTS (COM and LPT)**, expand and you should see a **COM PORT** number. Windows® 7 is similar.

Start the MCS-CONNECT software. Select **SETUP>COMMUNICATIONS** and then change **LOCAL COM PORT** to match your computer. Select **SAVE** and then **OK**.

Connecting to the Chiller

Connect the supplied NULL MODEM cable between your USB adapter or serial port to the chiller. A standard serial cable will not work. Start the MCS-CONNECT software and select **LOCAL SERIAL**. You will see the site info page. The software should scan and find the chiller. (If you see a Failed to open comm port error, or it scans and does not find the chiller, your comm port settings are not correct.) Click the **1-CCAR/CGWR** tab. The screen shows real time data.

Set Point Changes

Click the **VIEW ONLY** button. Enter the password code **2112**. Select **OK**. Button should say **SERVICE**. Go to set points and double-click on a value. Change and select **OK**.

Viewing and Troubleshooting ALARMS

The unit controller will record and store 30-second sensor input data prior to and up to any **LOCKOUT ALARM**. Select the **ALARM** tab, then **INFO** next to the alarm you want to analyze. This will pop up a screen that shows operating conditions just prior to the trip. You can easily determine if the fault was caused by a sudden or gradual change. For instance, a sudden increase in discharge pressure might suggest a condenser pump or fan failure etc. (This data can also be viewed from the chiller **LCD** screen. Select **LOCKOUT ALARMS**.)

Downloading and Viewing Graphs

The unit controller continuously records and stores sensor input and relay/analog output data. This data is collected in 10-second (default) intervals. The controller stores 1008 packets of data replacing the oldest with the newest. With the time interval set at 10 seconds, you can download graph

data with a time span of 168 minutes. The time interval is adjustable.

In the MCS-CONNECT software, select **GRAPH**. Data will be downloaded and then a graph setup page will appear. Select the input and output data you want to look at. Type in Y-axis parameters and select **OK**. Use the scroll bar at the bottom of the graph to view. You can go back to the setup page at any time to change selections. You may save the graph to view later. You do not have to be connected to view a saved graph file. Your saved graph will be located in a folder called **GRAPH** inside another folder called **MCS** on your **C:** drive.

To change the default 10-second interval, make changes and select **SAVE** and then **OK** on the setup page. The controller will now record data at this new interval.

To view a saved graph, select **LOAD A GRAPH FILE**. These files can be e-mailed to us for analysis if needed.

Updating Chiller Software and Configuration Files

Trane chillers are programmed, set up, and tested prior to shipment. Sometimes after a unit arrives at the jobsite, the customer may want to enable an option such as 0 to 5 Vdc target reset or chilled water pump control etc. These options require a configuration change. We will either have you download the configuration file from the chiller and e-mail it to us where we will modify it and return it to you, or we will modify a default configuration file we have here at the factory and send it to you. Modifying a configuration file you send us will save any setpoint changes that have been made on site. Otherwise, the controller will be set back to default factory settings.

To e-mail us a copy of your chillers configuration file, in the MCS-CONNECT software, establish communication with the chiller and select **RECEIVE CFG**. Name it something and e-mail it to engineering@nappstech.com.

To load a configuration file, turn off circuit enable switches and select **TRANSMIT CFG**. Locate the new file and press **OPEN**. The file will be uploaded to the controller. The controller will reboot itself.

Routine software (HEX FILE) updates are NOT necessary. However, if we think a software update is necessary to resolve an operating issue you may be having, we will e-mail the hex file in a zipped folder. Save the zipped folder to your desktop. Right click folder and select **EXTRACT ALL**. This will create another folder by the same name on your desktop. Inside this folder you will find the hex file. It should be about 2300 KB large.

In the MCS-CONNECT software, select **TRANSMIT SW**. Locate the *extracted* hex file and select **Transmit**. Watch the chiller LCD screen. After the file is uploaded, the Trane MCS Digital Controller will verify that it is a valid file and then erase the flash memory. Next, it will write the new hex to memory. When completed, the controller will reboot itself. This process may take 15 or 20 minutes. After the reboot is completed, close

and restart the MCS-CONNECT software to reestablish communication with the chiller.



Unit Start-Up Procedures

NOTICE

Compressor Failure!

Failure to follow instructions could result in compressor damage. Keep crankcase heaters on whenever refrigerant is in the system. If crankcase heaters have not been on with refrigerant in the system, turn the crankcase heaters on for a minimum of 24 hours before starting compressors.

Prior to calling for start-up services or commissioning, *CGWR Installation Completion Check List and Request for Trane Service (CG-ADF005*-EN)* or *CCAR Installation Completion Check List and Request for Trane Service (CG-ADF006*-EN)*, as appropriate, must be completed and submitted. Once *CG-ADF005*-EN* or *CG-ADF006*-EN* has been submitted, *Start-up Check List for CGWR and CCAR Chillers (CG-ADF007*-EN)* must be followed and submitted.

Pre-Start Up Procedures Check List

Complete each step in the Pre-Start Up Procedures check list included in *Start-up Check List for CGWR and CCAR Chillers (CG-ADF007*-EN)* and check off each step as completed.

NOTICE

Equipment Damage!

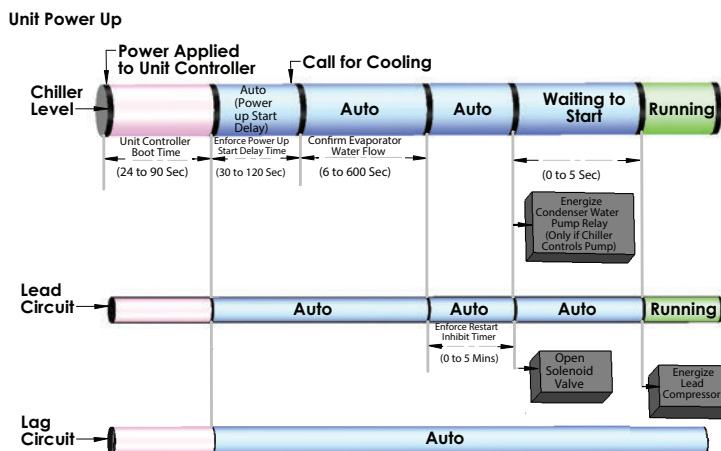
- To prevent overheating at connections and under-voltage conditions at the compressor motor, check tightness of all connections in the compressor power circuit.
- Failure to follow instructions below could result in compressor failure due to lack of refrigerant and/or oil flow. Fully open all compressor service valves (suction, discharge, liquid line, and oil line) prior to start-up.
- The use of untreated or improperly treated water in a Chiller may result in scaling, erosion, corrosion, algae or slime. Use the services of a qualified water treatment specialist to determine what water treatment, if any, is required. Trane assumes no responsibility for equipment failures which result from untreated or improperly treated water, or saline or brackish water.
- To prevent components damage, pipe strainers must be installed in the water supplies to protect components from water borne debris. Trane is not responsible for equipment-only-damage caused by water borne debris.

⚠ WARNING

Hazardous Voltage!

Failure to disconnect power before servicing could result in death or serious injury. Disconnect all electric power, including remote disconnects before servicing. Follow proper lockout/tagout procedures to ensure the power can not be inadvertently energized. Verify that no power is present with a voltmeter.

Sequence of Operation



Checking Operating Conditions

NOTICE

Evaporator/Condenser Damage!

Water (fluid) flow must be established in evaporator and condenser before adding refrigerate, removing refrigerate, or pulling vacuum, to protect heat exchangers from freezing.

NOTICE

Compressor Damage!

Do not allow liquid refrigerant to enter the suction line as excessive liquid accumulation in the liquid lines could result in compressor damage.

To prevent compressor damage and ensure full cooling capacity, use refrigerants specified on the unit nameplate only.

- If operating conditions indicate an overcharge, slowly (to minimize oil loss) remove refrigerant at the liquid line Schrader fitting. Do not discharge refrigerant into the atmosphere.
- If the remote condenser (CCAR) is equipped with low ambient dampers, check for proper actuator and blade travel in relation to condensing pressure.
- Once proper unit operation is confirmed, inspect for debris, misplaced tools., etc. Secure control panel doors in place.

Once the unit has been operating for about 10 minutes and the system has stabilized, check operating conditions and complete the checkout procedures that follow.

- Recheck evaporator water and condenser (CGWR) water flows and pressure drops. These readings should be stable at proper levels.
- Check suction pressure and discharge pressure of the unit.

Discharge pressures—take at Schrader fitting provided on the discharge line. Normal discharge pressures are:

CCAR units: 315 psig to 500 psig

CGWR units: 275 psig to 430 psig

Suction pressures— take at Schrader fitting provided on the suction line. Normal suction pressures are:

42°F to 60°F LWT: 104 to 155 psig

15°F to 39°F LWT: 60 to 103 psig

- Check compressor oil levels. At full load, oil level should be visible in the oil level sight glass on the compressor. If it is not, add or remove oil as required.
- Check the liquid line sight glasses. Refrigerant flow past the sight glasses should be clear. Bubbles in the liquid line indicate either low refrigerant charge or excessive pressure drop in the liquid line. Such a restriction can often be identified by a noticeable temperature differential on

either side of the restricted area. Frost often forms on the outside of the liquid line at this point also.

The system may not be properly charged although the sight glass is clear. Also consider superheat, sub-cooling and operating pressure.

- Once oil level, amp draw and operating pressures have stabilized, measure system suction superheat.
- Measure system liquid line sub-cooling.
- If operating pressure, sight glass, superheat and sub-cooling readings indicate refrigerant shortage, charge refrigerant into each circuit. Refrigerant shortage is indicated if operating pressures are low and sub-cooling is also low.

If suction and discharge pressures are low but sub-cooling is normal, no refrigerant shortage exists. Adding refrigerant, will result in overcharging.

Add refrigerant with the unit running by metering liquid refrigerant through the Schrader valve between the expansion valve and the evaporator refrigerant inlet until operating conditions are normal.

System Superheat

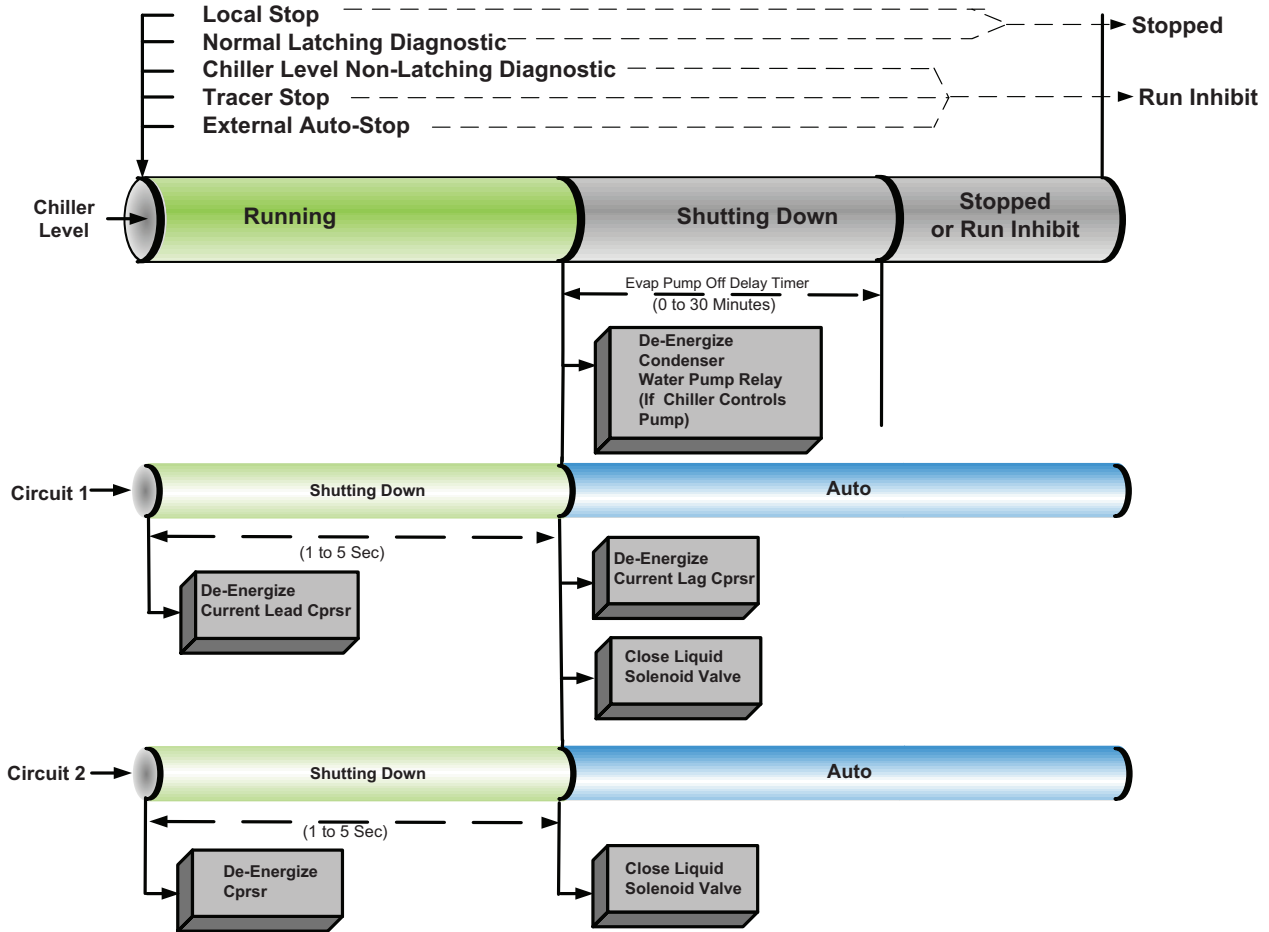
Normal superheat for each circuit is 10°F to 16°F at full load. If superheat is not within this range, adjust expansion valve superheat setting. Allow 5 to 10 minutes between adjustments for the expansion valve to stabilize on each new setting.

System Sub-cooling

Normal sub-cooling for each circuit is 5°F to 10°F at full load where saturated discharge pressure and liquid line temperature are measured at chiller liquid line.

Unit Shutdown

Normal Unit Shutdown



Extended Shutdown Procedure

If the system is taken out of operation for long periods of time, use this procedure to prepare the system for shutdown.

1. Test condenser and high side piping for refrigerant leakage.
2. Open electrical disconnect switches for evaporator water pump. Lock the disconnect in an open position.
3. Open the unit main electrical disconnect and unit-mounted disconnect (if used) and lock in open position.



Unit Restart

Unit Restart After Extended Shutdown

Use this procedure to prepare the system for restart after an extended shutdown.

NOTICE

Compressor Failure!

Failure to follow instructions could result in compressor damage.

Keep crankcase heaters on whenever refrigerant is in the system. If crankcase heaters have not been on with refrigerant in the system, turn the crankcase heaters on for a minimum of 24 hours before starting compressors.

NOTICE

Compressor Damage!

To prevent compressor damage, be certain that all refrigerant valves are open before starting the unit.

1. Close the unit main disconnect(s) and the unit-mounted disconnect (if used).
2. Check compressor crankcase oil levels. Oil should be visible in the compressor oil level sight glass.
3. Fill the chilled water circuit(s) if drained during shutdown. Vent the system while filling it.
4. Close the fused disconnect switch(es) for the water pumps.
5. Start the water pump(s). With water pumps running, inspect all piping connections for leakage. Make any necessary repairs.
6. With water pump(s) running, adjust chilled water flow and check water pressure drop through the evaporator.
7. Check the flow switch on the evaporator outlet piping for proper operation.
8. Stop the water pump(s).
9. Complete each step in Trane literature *Start-up Check List for CGWR and CCAR Chillers* (CGWR-ADF002*-EN).
10. Energize Crankcase Heaters (Must be energized 24 hours before start-up).



Maintenance

⚠ WARNING

Hazardous Service Procedures!

Failure to follow all precautions in this manual and on the tags, stickers, and labels could result in death or serious injury.

Technicians, in order to protect themselves from potential electrical, mechanical, and chemical hazards, **MUST** follow precautions in this manual and on the tags, stickers, and labels, as well as the following instructions: Unless specified otherwise, disconnect all electrical power including remote disconnect and discharge all energy storing devices such as capacitors before servicing. Follow proper lockout/tagout procedures to ensure the power can not be inadvertently energized. When necessary to work with live electrical components, have a qualified licensed electrician or other individual who has been trained in handling live electrical components perform these tasks.

Because scroll compressors are a uniquely different design from traditional reciprocating compressors, their operating characteristics and requirements are a departure from the reciprocating compressor technology.

Compressor Oil

The R-410A scroll compressor uses POE oil as required by the manufacturer of the compressor. Refer to compressor manufacturer for exact type and amount of oil in the specific model in question.

Oil Level: While the compressor is running, the oil level may be below the sight glass but still visible through the sight glass. The oil level should never be above the sight glass!

Oil Appearance: If the oil is dark and smells burnt, it was overheated because of compressor operation at extremely high condensing temperatures, a compressor mechanical failure, or occurrence of a motor burnout. If the oil is black and contains metal flakes, a mechanical failure has occurred. This symptom is often accompanied by a high amperage draw at the compressor motor.

Notes:

- *If a motor burnout is suspected, use an acid test kit to check the condition of the oil. If a burnout has occurred, test results will indicate an acid level exceeding 0.05 mg KOH/g.*
- *The use of commercially available oil additives is not recommended. Liability for any detrimental effects that the use of non-approved products may have on equipment performance or longevity must be assumed by the equipment owner, equipment servicer, or the oil additive manufacturer.*

Scroll Compressor Functional Test

Since the scroll compressor does not use discharge or suction valves, it is not necessary to perform a pump-down capability test, i.e. a test where the liquid line valve is closed and the compressor is pumped in a vacuum to see if it will pump-down and hold. If fact, this kind of test may actually damage the scroll compressor!

NOTICE

Compressor Damage!

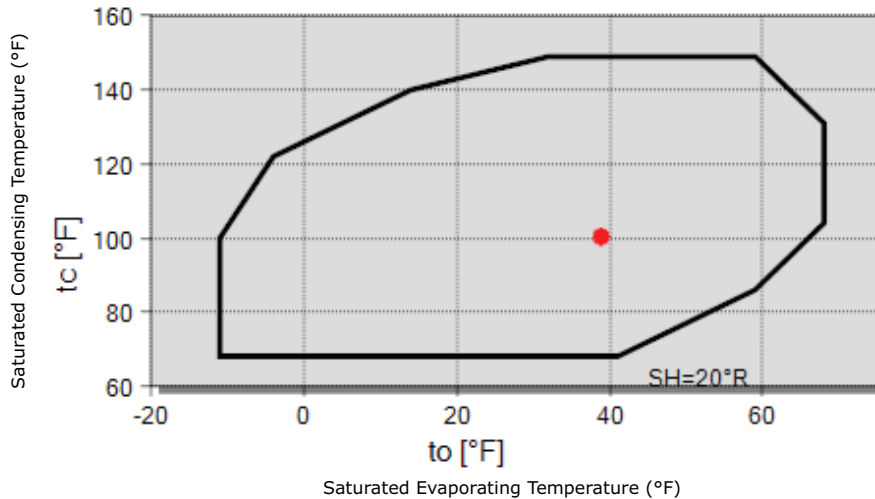
Do not pump the scroll compressor into a vacuum. Scroll compressors can pull internal low vacuums when the suction side is closed or restricted. This, in turn, may cause the internal Fusite[®] terminal to arc, resulting in compressor damage or failure. It may also trip the circuit breakers, blow fuses, or trip the discharge thermostat.

The proper procedure for checking scroll compressor operation is outlined below:

1. Verify that the compressor is receiving supply power of the proper voltage.
2. With the compressor running, measure the suction and discharge pressures/temperatures to determine whether or not they fall within the compressor operating map shown in figure below.

See "[Checking Operating Conditions](#)," p. 35 for normal operating pressure ranges for the unit.

Figure 7. Compressor operating map



Compressor Operational Noises

Because the scroll compressor is designed to accommodate liquids (both oil and refrigerant) and solid particles without causing compressor damage, there are some characteristic sounds that differentiate it from those typically associated with a reciprocating compressor. These sounds, which are described below, are normal and do not indicate that the compressor is defective.

At low ambient start-up: When the compressor starts up under low ambient conditions, the initial flow rate of the compressor is low. Under these conditions, it is not unusual to hear the compressor rattle until the suction pressure climbs and the flow rate increases. These sounds are *normal* and do not affect the operation or reliability of the compressor.

Excessive Amp Draw

Excessive Amp Draw occurs either because the compressor is operating at an abnormally high condensing temperature OR because of low voltage at the compressor motor.

Motor amp draw may also be excessive if the compressor has internal mechanical damage. In this situation, vibration and discolored oil can also be observed.

Low Suctions

Continuous low suction pressures are most likely caused by low evaporator load coupled with a system anomaly. Symptoms that may accompany low suction include a rattling sound emitted from the compressor or an open motor winding thermostat or discharge thermostat.

Note: *Operation of the chiller with saturated suction temperatures below freezing will cause damage to the evaporator. If this occurs immediately stop the machine, diagnose and correct the problem.*

Periodic Maintenance

Perform all of the indicated maintenance procedures at the intervals scheduled. This will prolong the life of the unit and reduce the possibility of costly equipment failure.

Weekly Maintenance

Once the unit has been operating for about 10 minutes and the system has stabilized, check operating conditions and complete the checkout procedures that follow.

1. Check compressor oil levels. Oil should be visible in the sight glass when the compressor is running. Operate the compressors for a minimum of three to four hours when checking oil level, and check level every 30 minutes. If oil is not at proper level after this period, have a qualified service representative add or remove oil as required.
2. Check suction pressure and discharge pressure.
3. Check the liquid line sight glasses.
4. If operating pressures and sight glass conditions seem to indicate refrigerant shortage, measure system superheat and system sub-cooling.
5. If operating conditions indicate an overcharge, slowly (to minimize oil loss) remove refrigerant at the liquid line service valve.
6. Inspect remote condenser coils for cleanliness (CCAR only) and clean if required. Refer to the condenser manufacturers recommendations.
7. Inspect the entire system for unusual conditions. Use an operating log to record a weekly operating conditions history for the unit. A complete operating log is a valuable diagnostic tool for service personnel.



Maintenance

Monthly Maintenance

Once the unit has been operating for about 10 minutes and the system has stabilized, check operating conditions and complete the checkout procedures that follow.

1. Perform all weekly maintenance procedures.
2. Check refrigerant superheat at the compressor suction line. Superheat should be in the range of 10°F to 20°F.

Note: *A superheat calculated value is incorporated into the unit controller.*

3. Inspect the entire system for unusual conditions. Review the weekly operating log for conditions history for the unit and take note of any unusual trends in performance. Take appropriate preventative actions if necessary.

Annually

Perform all weekly and monthly maintenance procedures.

1. Have a qualified service technician check the setting and function of each control and inspect the condition of and replace compressor and control contacts if needed.
2. If chiller is not piped to drain facilities, make sure drain is clear to carry away system water.
3. Drain water from condenser (CGWR only) and evaporator and associated piping systems. Inspect all piping components for leakage, damage, etc. Clean out required evaporator strainer.
4. Inspect condenser tubes and clean, if needed.
5. Clean and repaint any corroded surface.
6. Clean remote condenser coils (CCAR only). Refer to the condenser manufacturers recommendations.



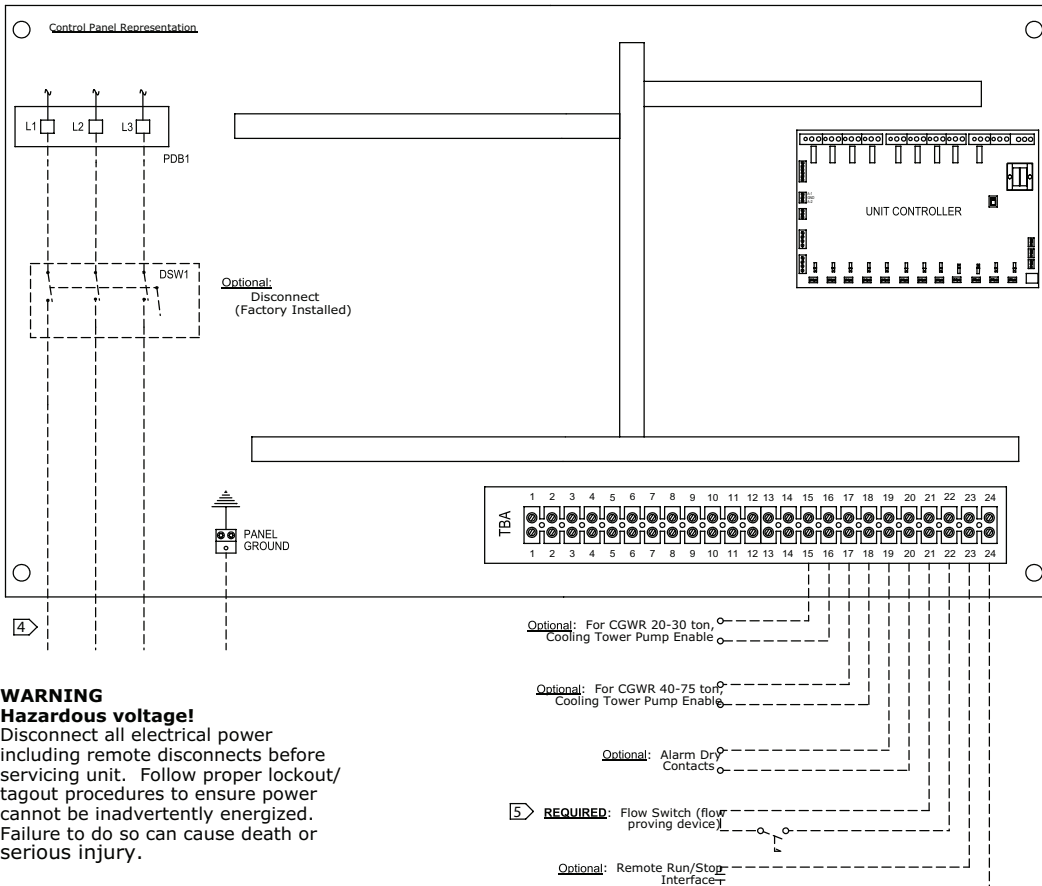
Electrical Schematics

CGWR Water-Cooled Chillers

CGWR Field Wiring

Figure 8. Field wiring for 20 to 75 ton, R-410A CGWR water-cooled chillers

Field Wiring - CGWR Scroll Water Chillers



WARNING
Hazardous voltage!
 Disconnect all electrical power including remote disconnects before servicing unit. Follow proper lockout/tagout procedures to ensure power cannot be inadvertently energized. Failure to do so can cause death or serious injury.

CAUTION
 Use copper conductors only!
 Unit terminals are not designed to accept other type conductors. Failure to use copper conductors may cause equipment damage.

CAUTION
 Do not energize the unit until check-out and start-up procedures have been completed.

Notes:

1. All three-phase motors supplied with the unit are protected under primary single-phase failure conditions.
2. All customer control-circuit wiring must have a minimum rating of 150V.
3. All field wiring must be in accordance with applicable local codes. Line voltage options. Single or dual source power may be specified. Drawing covers single source power only. All field wiring must be in accordance with National Electric Code and State & Local requirements.
4. (Required) Factory supplied or approved alternate field installed flow proving device connection.

NAME	DATE	TRANE	
DRAWN	SMH	3/22/17	CGWR Field Wiring Diagram
CHECKED	BAR	3/22/17	
ENG APPR.			
MFG APPR.			
G.A.			
COMMENTS: Revised to add 75 ton. 10-18-19			SIZE DWG. NO. A CGWR Field Wiring
SCALE: 1:5		WEIGHT:	REV. 1 SHEET 1 OF 1



Electrical Schematics

CGWR Power/Control Wiring

Refer to name plate on control box door (inside) for electrical data and wiring diagram.

Figure 9. Power/control wiring schematic for 20 to 30 ton, R-410A CGWR water-cooled chillers

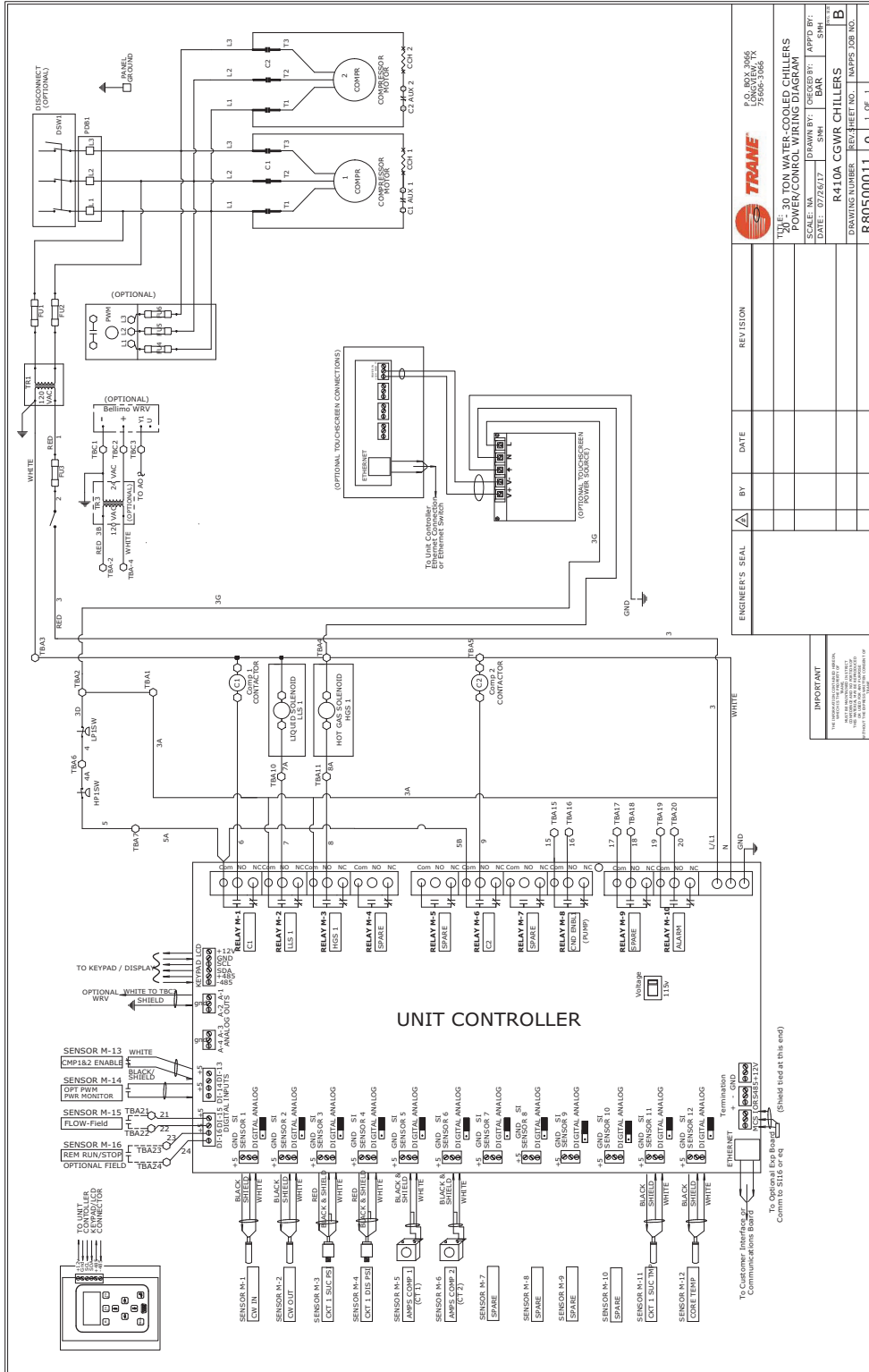


Figure 10. Power/control wiring schematic for 40 to 75 ton, R-410A CGWR water-cooled chillers

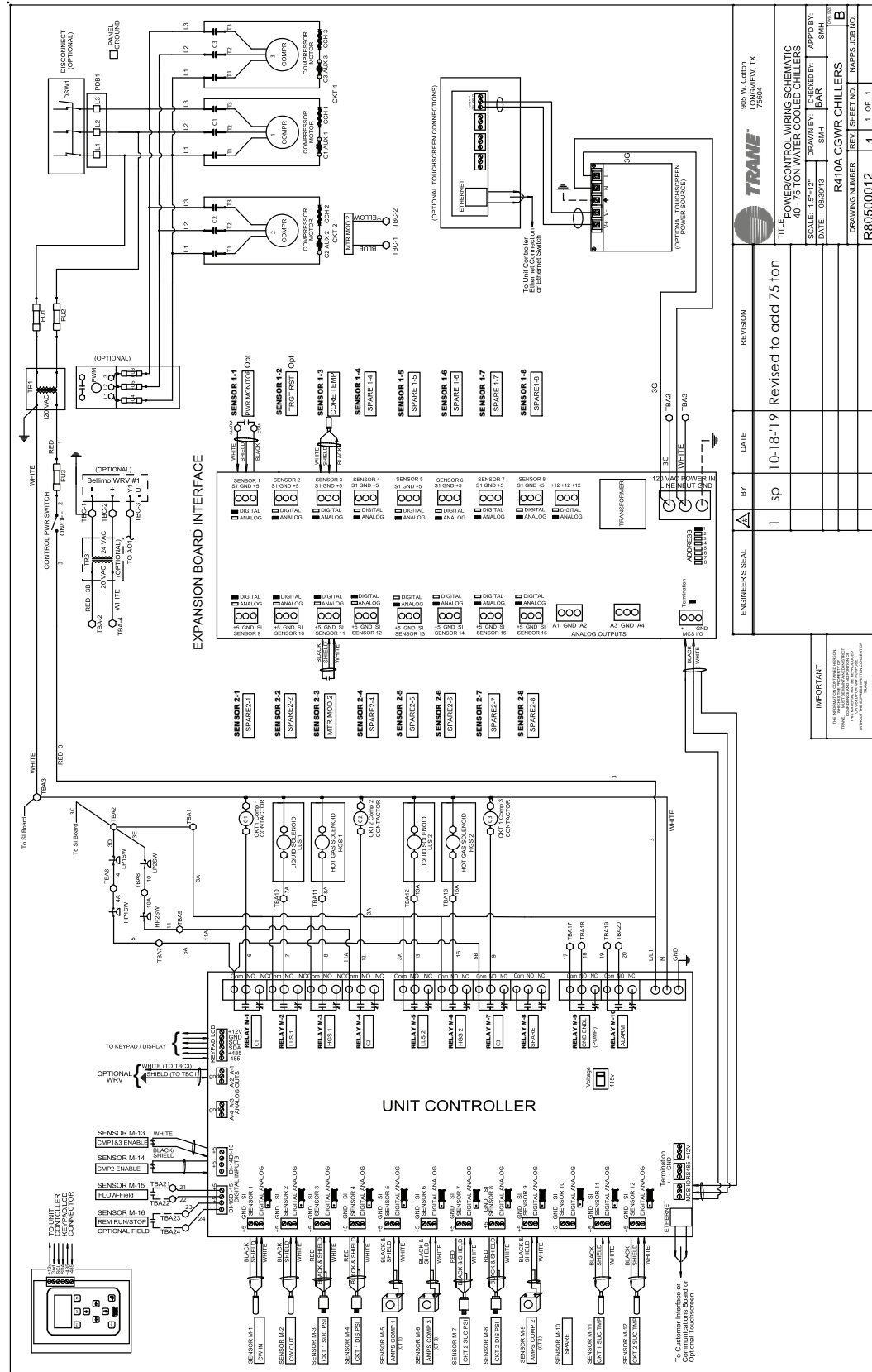


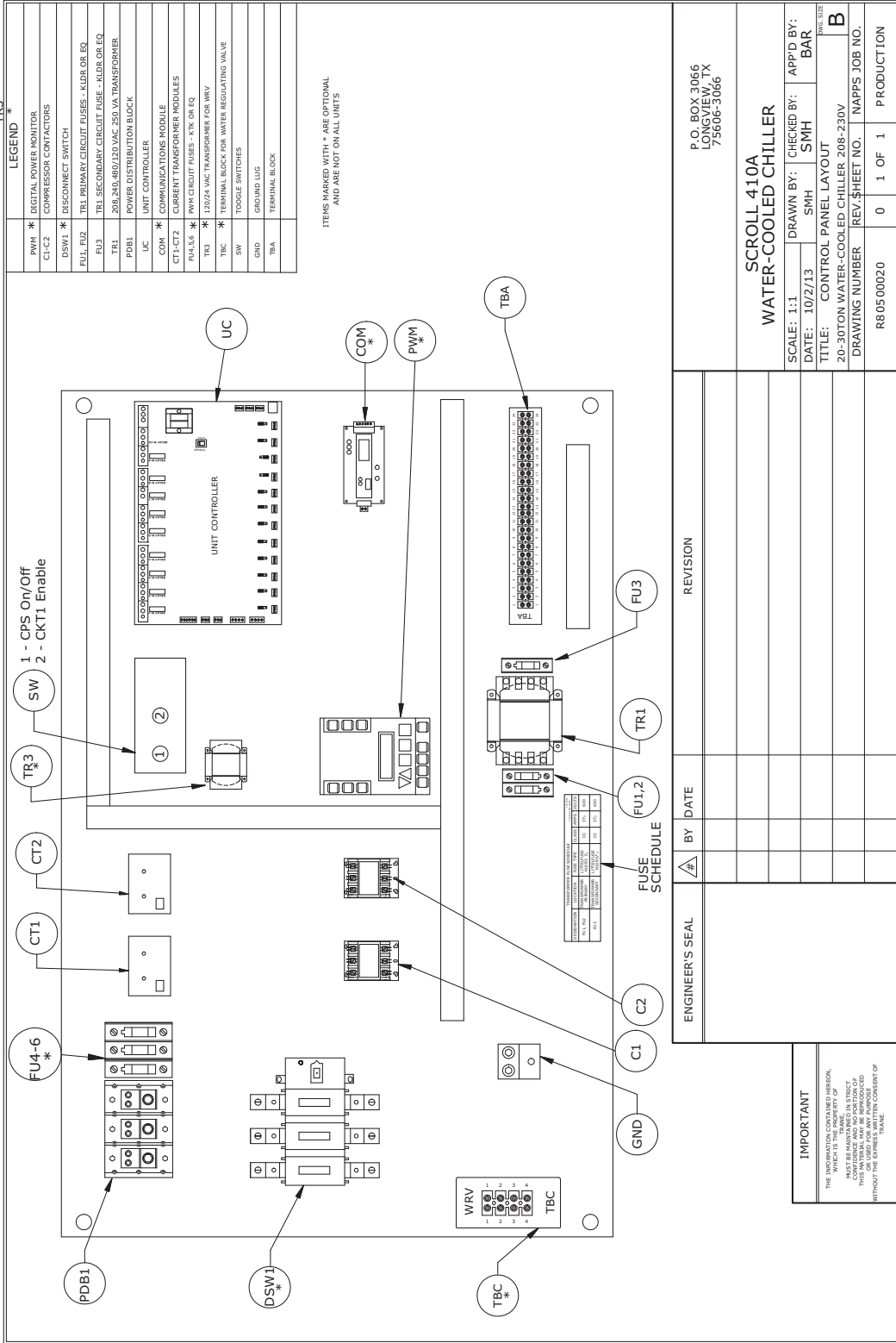
Figure 11. Control panel layout for 20 to 30 ton, 208V, R-410A CGWR water-cooled chillers

Figure 12. Control panel layout for 20 to 30 ton, 460V, R-410A CGWR water-cooled chillers

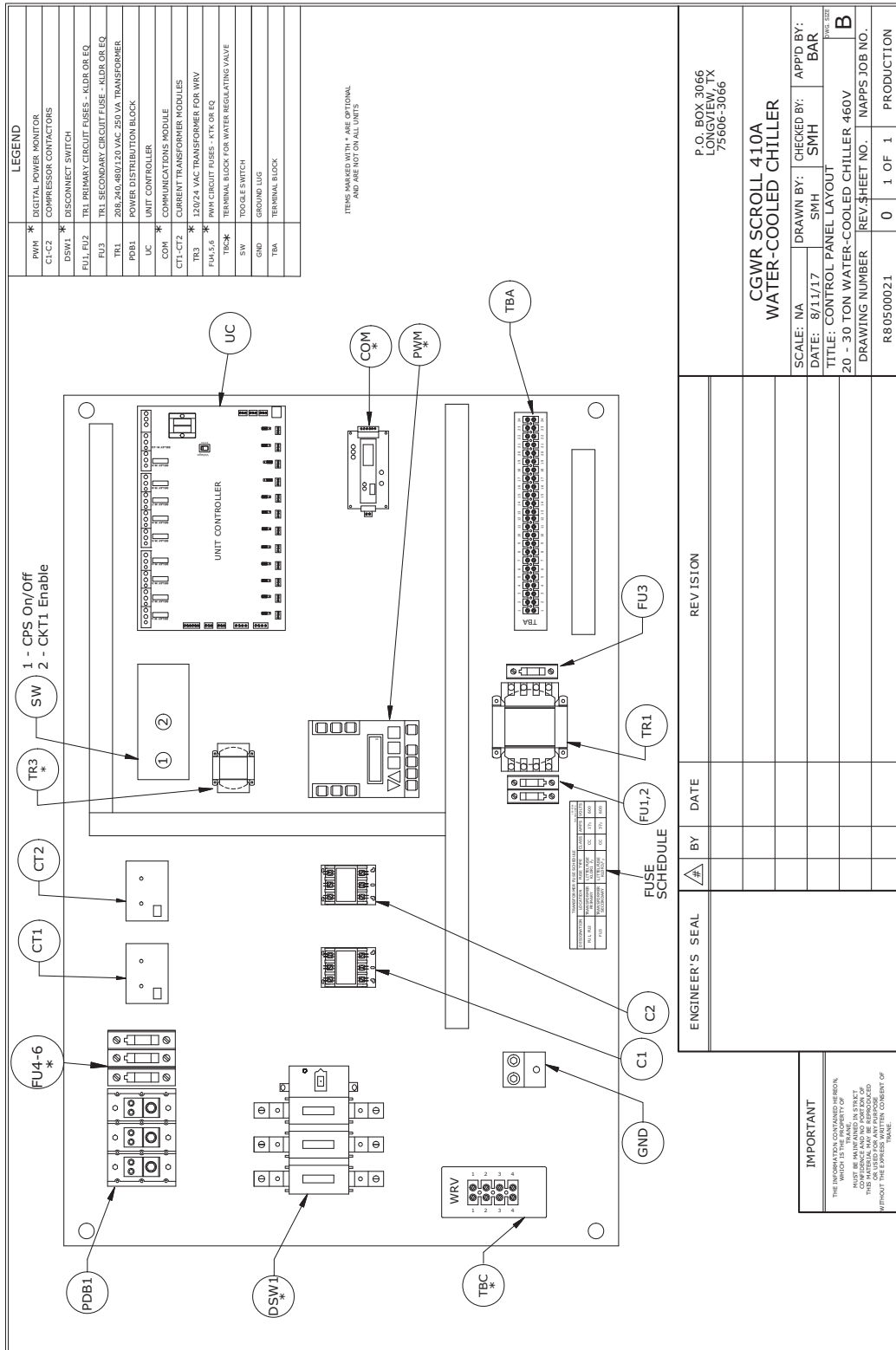
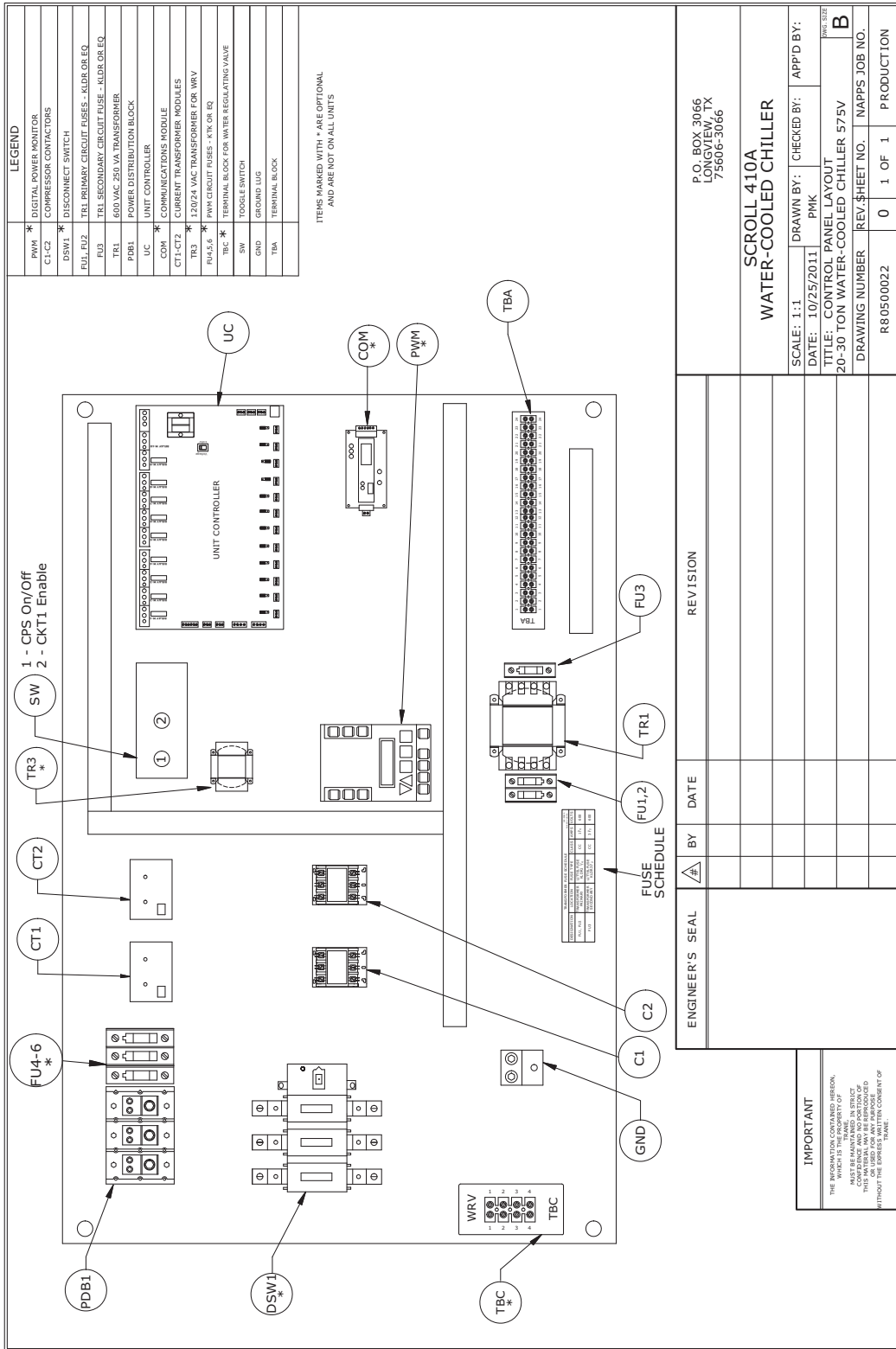


Figure 13. Control panel layout for 20 to 30 ton, 575V, R-410A CGWR water-cooled chillers



LEGEND	
PWM *	DIGITAL POWER MONITOR
CT1-CT2	COMPRESSOR CONTACTORS
DSW1 *	DISCONNECT SWITCH
FU1, FU2	TBL PRIMARY CIRCUIT FUSES - KLDK OR EQ.
FU3	TBL SECONDARY CIRCUIT FUSE - KLDK OR EQ.
TR3	600 VAC 250 VA TRANSFORMER
PDB1	POWER DISTRIBUTION BLOCK
UC	UNIT CONTROLLER
COM *	COMMUNICATIONS MODULE
CT1-CT2	CURRENT TRANSFORMER MODULES
TR3	120/24 VAC TRANSFORMER FOR WRV
PA-5,6	PWM CIRCUIT FUSES - KTK OR EQ.
TBC *	TERMINAL BLOCK FOR WATER REGULATING VALVE
SW	TOGGLE SWITCH
GND	GROUND LUG
TBA	TERMINAL BLOCK

ITEMS MARKED WITH * ARE OPTIONAL AND ARE NOT ON ALL UNITS

ENGINEER'S SEAL		BY	DATE	REVISION

SCROLL 410A WATER-COOLED CHILLER

P.O. BOX 3066
LONGVIEW, TX
75606-3066

SCALE: 1:1 DRAWN BY: PMK CHECKED BY: APP'D BY: REV. 002

DATE: 10/25/2011

TITLE: CONTROL PANEL LAYOUT

20-30 TON WATER-COOLED CHILLER 575V

DRAWING NUMBER: REV. SHEET NO. NAPPS JOB NO. PRODUCTION

R80500022 0 1 OF 1 1 PRODUCTION

IMPORTANT

THE INFORMATION CONTAINED HEREON, WHICH IS THE PROPERTY OF TRANE, IS TO BE USED IN CONFIDENCE AND NO PART OF IT IS TO BE REPRODUCED OR USED FOR ANY PURPOSE WITHOUT THE EXPRESS CONSENT OF TRANE.

Figure 14. Control panel layout for 40 to 75 ton, 208V, R-410A CGWR water-cooled chillers

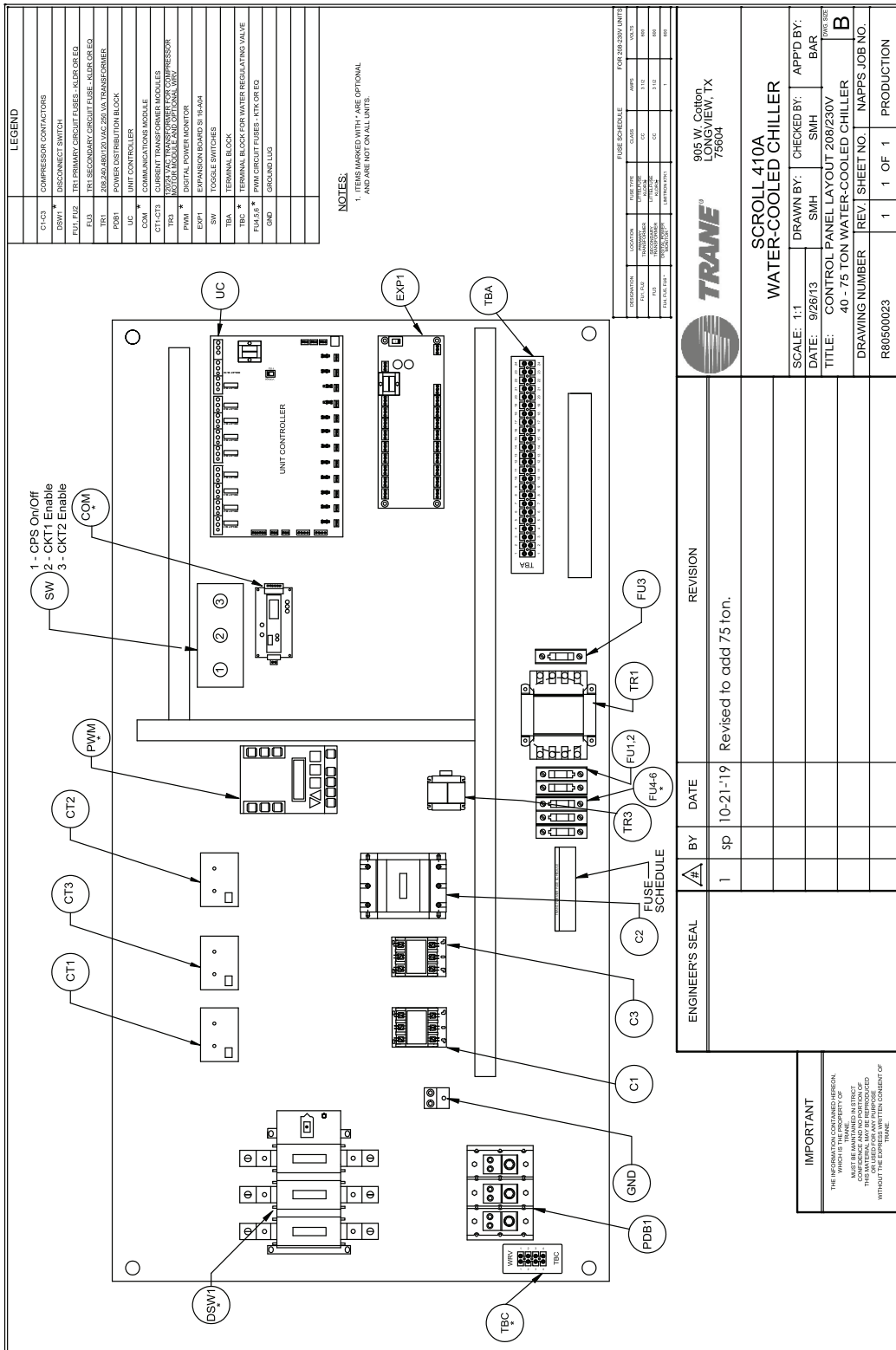


Figure 15. Control panel layout for 40 to 75 ton, 460V, R-410A CGWR water-cooled chillers

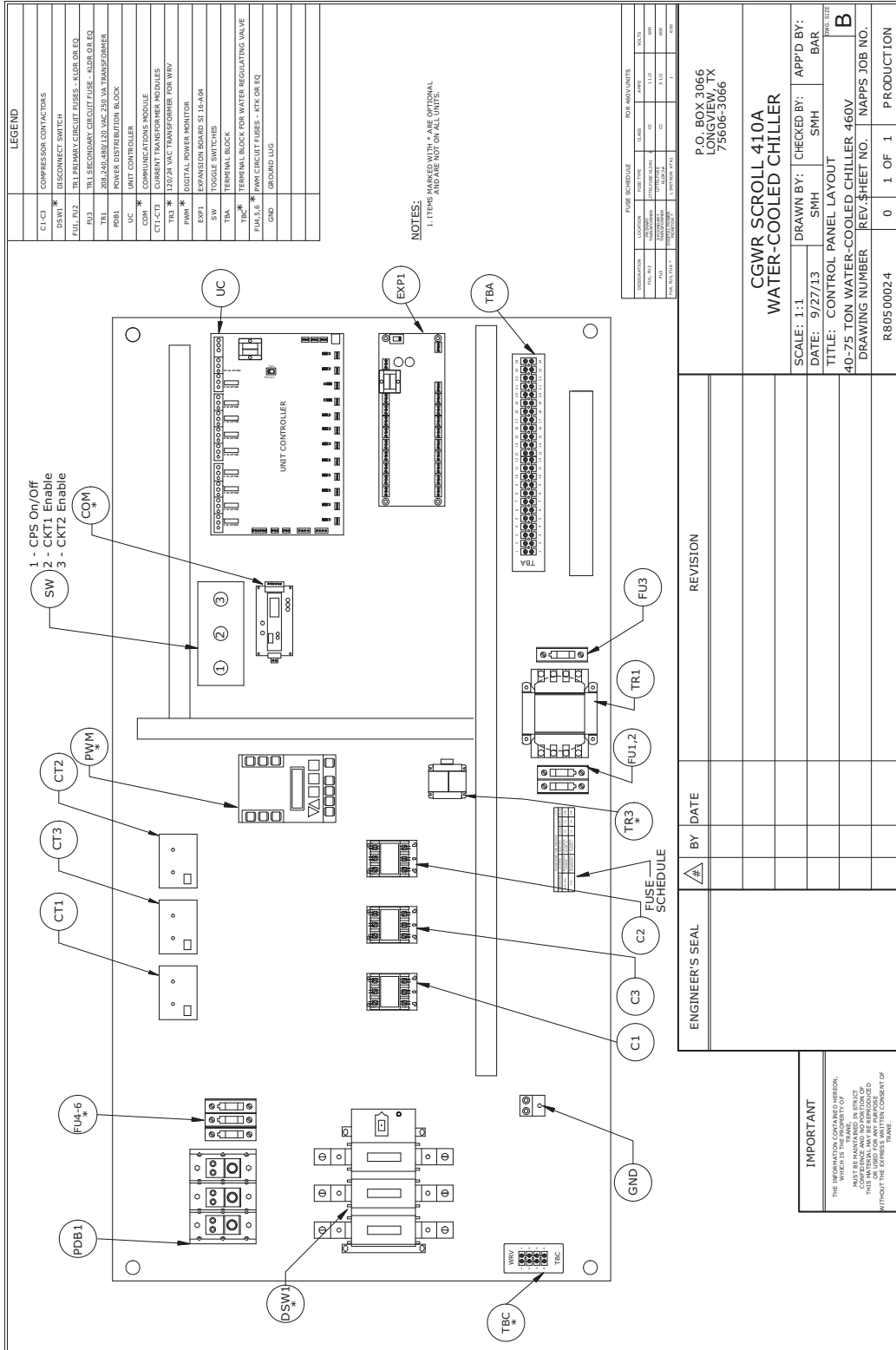
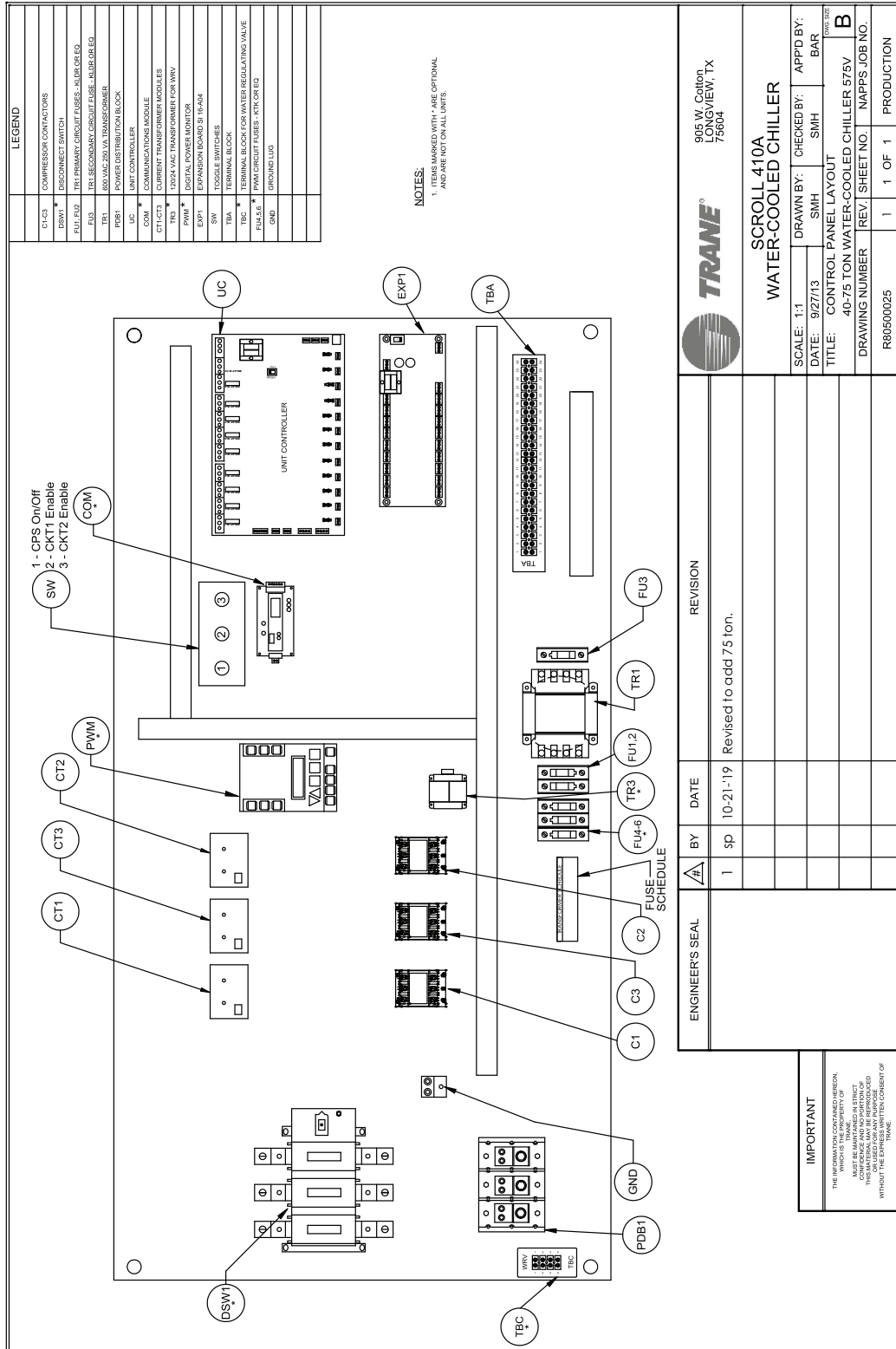


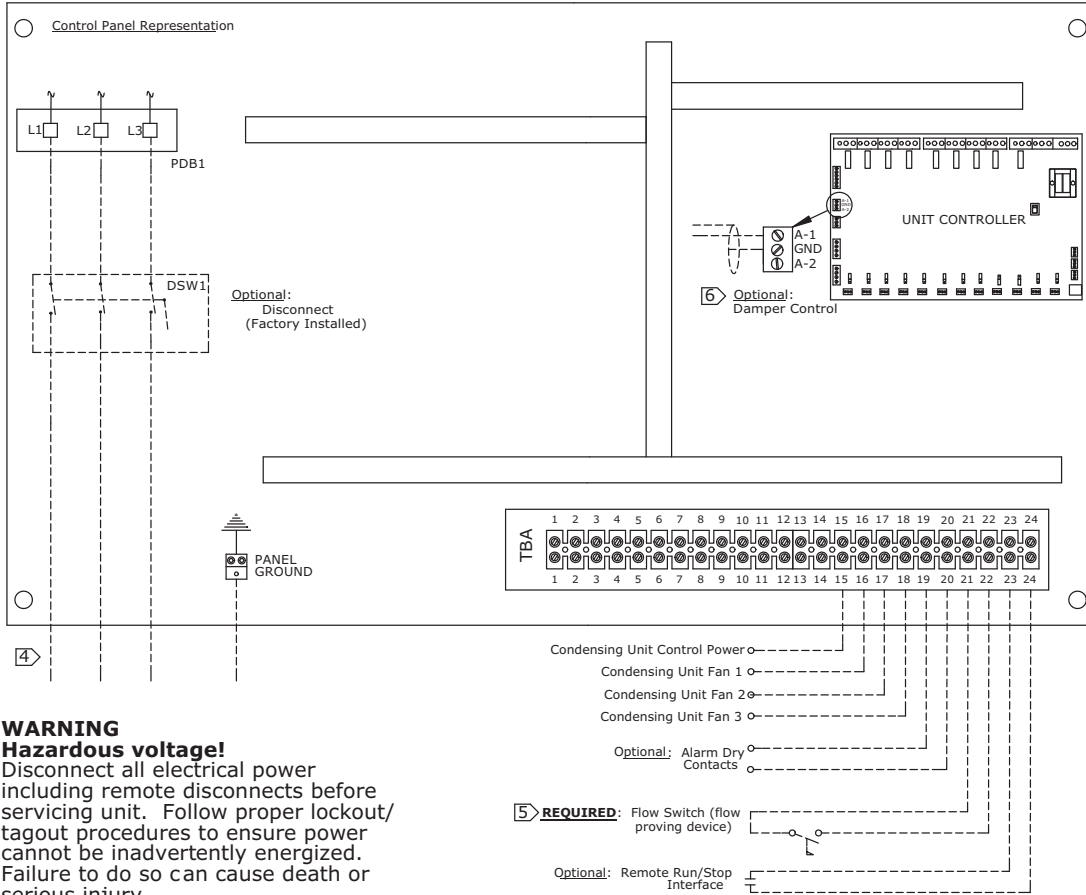
Figure 16. Control panel layout for 40 to 75 ton, 575V, R-410A CGWR water-cooled chillers



CCAR Compressor Chillers

CCAR Field Wiring

Figure 17. Field wiring diagram for 20 to 30 ton, R-410A CCAR compressor chillers



WARNING

Hazardous voltage!

Disconnect all electrical power including remote disconnects before servicing unit. Follow proper lockout/tagout procedures to ensure power cannot be inadvertently energized. Failure to do so can cause death or serious injury.

CAUTION

Use copper conductors only!

Unit terminals are not designed to accept other type conductors. Failure to use copper conductors may cause equipment damage.

CAUTION

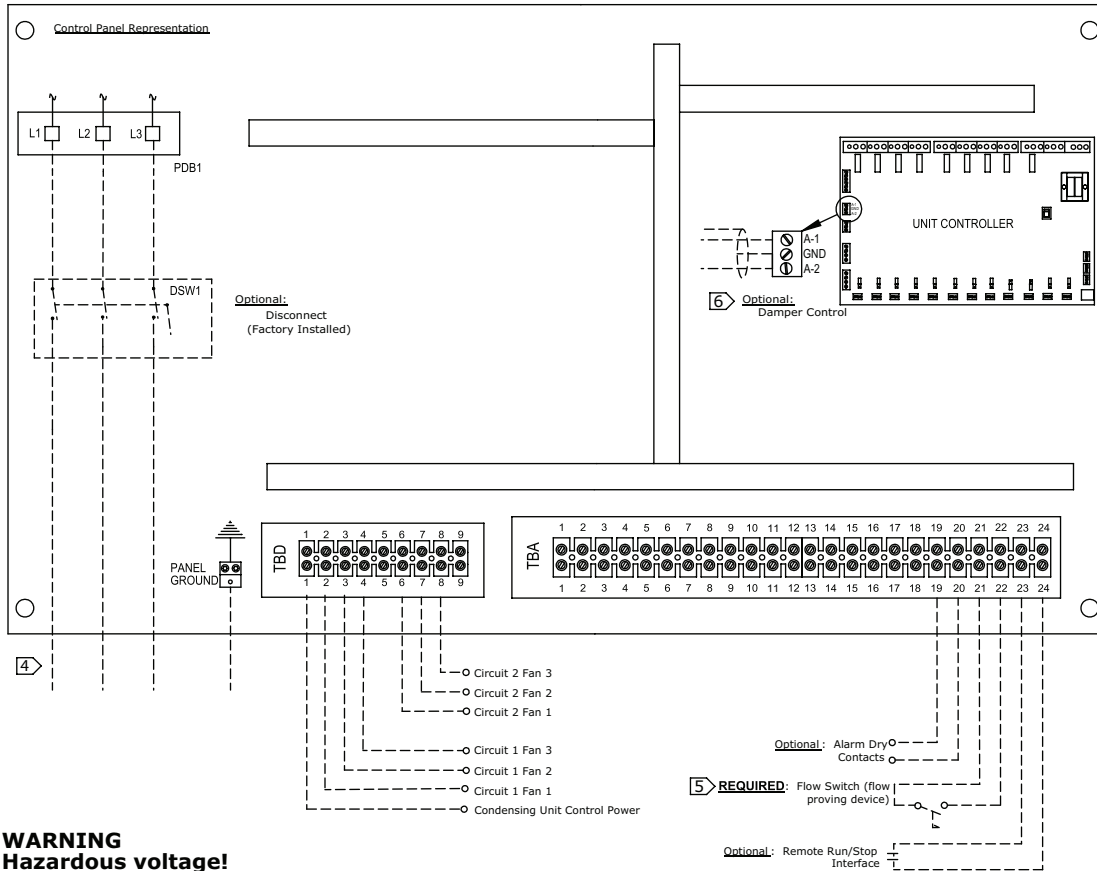
Do not energize the unit until check-out and start-up procedures have been completed.

Notes:

1. All three-phase motors supplied with the unit are protected under primary single-phase failure conditions.
2. All customer control-circuit wiring must have a minimum rating of 150V.
3. All field wiring must be in accordance with applicable local codes. Line voltage options. Single or dual source power may be specified.
4. Drawing covers single source power only. All field wiring must be in accordance with National Electric Code and State & Local requirements.
5. (Required) Factory supplied or approved alternate field installed flow proving device connection.
6. (Optional) Damper control option. Refer to operation and maintenance manual for additional information. This point intended to operate a low ambient damper on a remote air-cooled condenser. Wiring to be 2-wire shielded cable between outdoor unit and Trane indoor chiller.
7. If installing with a Trane CAUJ air-cooled condenser, more specific field wiring instructions can be found in the operations and maintenance manual.

NAME	DATE		
DRAWN SMH	3/22/17	<h3>CCAR 20-30 Ton Field Wiring Diagram</h3>	
CHECKED BAR	3/22/17		
ENG APPR.			
MFG APPR.			
Q.A.			
COMMENTS:		SIZE A DWG. NO. Field Wiring Single Circuit CCAR SCALE: 1:5 WEIGHT: REV. 0	
		SHEET 1 OF 1	

Figure 18. Field wiring diagram for 40 to 75 ton, R-410A CCAR compressor chillers



WARNING
Hazardous voltage!

Disconnect all electrical power including remote disconnects before servicing. Follow proper lockout/tagout procedures to ensure power cannot be inadvertently energized. Failure to do so can cause death or serious injury.

CAUTION

Use copper conductors only! Unit terminals are not designed to accept other type conductors. Failure to use copper conductors may cause equipment damage.

CAUTION

Do not energize the unit until check-out and start-up procedures have been completed.

Notes:

1. All three-phase motors supplied with the unit are protected under primary single-phase failure conditions.
2. All customer control-circuit wiring must have a minimum rating of 150V.
3. All field wiring must be in accordance with applicable local codes.
4. Line voltage options. Single or dual source power may be specified. Drawing covers single source power only. All field wiring must be in accordance with National Electric Code and State & Local requirements.
5. (Required) Factory supplied or approved alternate field installed flow proving device connection.
6. (Optional) Damper control option. Refer to operation and maintenance manual for additional information. This point intended to operate low ambient dampers on a remote air-cooled condenser, (1) damper per AO. Wiring to be 2-wire shielded cable between outdoor unit and Trane indoor chiller.
7. If installing with a Trane CAUJ air-cooled condenser, more specific field wiring instructions can be found in the operations and maintenance manual.

	NAME	DATE	 CCAR 40-75 Ton Field Wiring Diagram	REV.	
DRAWN	SMH	3/23/17			1
CHECKED	BAR	3/23/17			
ENG APPR.					
MFG APPR.					
COMMENTS: Revised to add 75 ton. 10-18-19			SIZE A	DWG. NO. Dual Circuit CCAR Field Wiring	
			SCALE: 1:5	WEIGHT:	
			SHEET 1 OF 1		



Electrical Schematics

CCAR Power/Control Wiring

Refer to name plate on control box door (inside) for electrical data and wiring diagram.

Figure 19. Power/control wiring schematic for 20 to 30 ton, R-410A CCAR compressor chillers

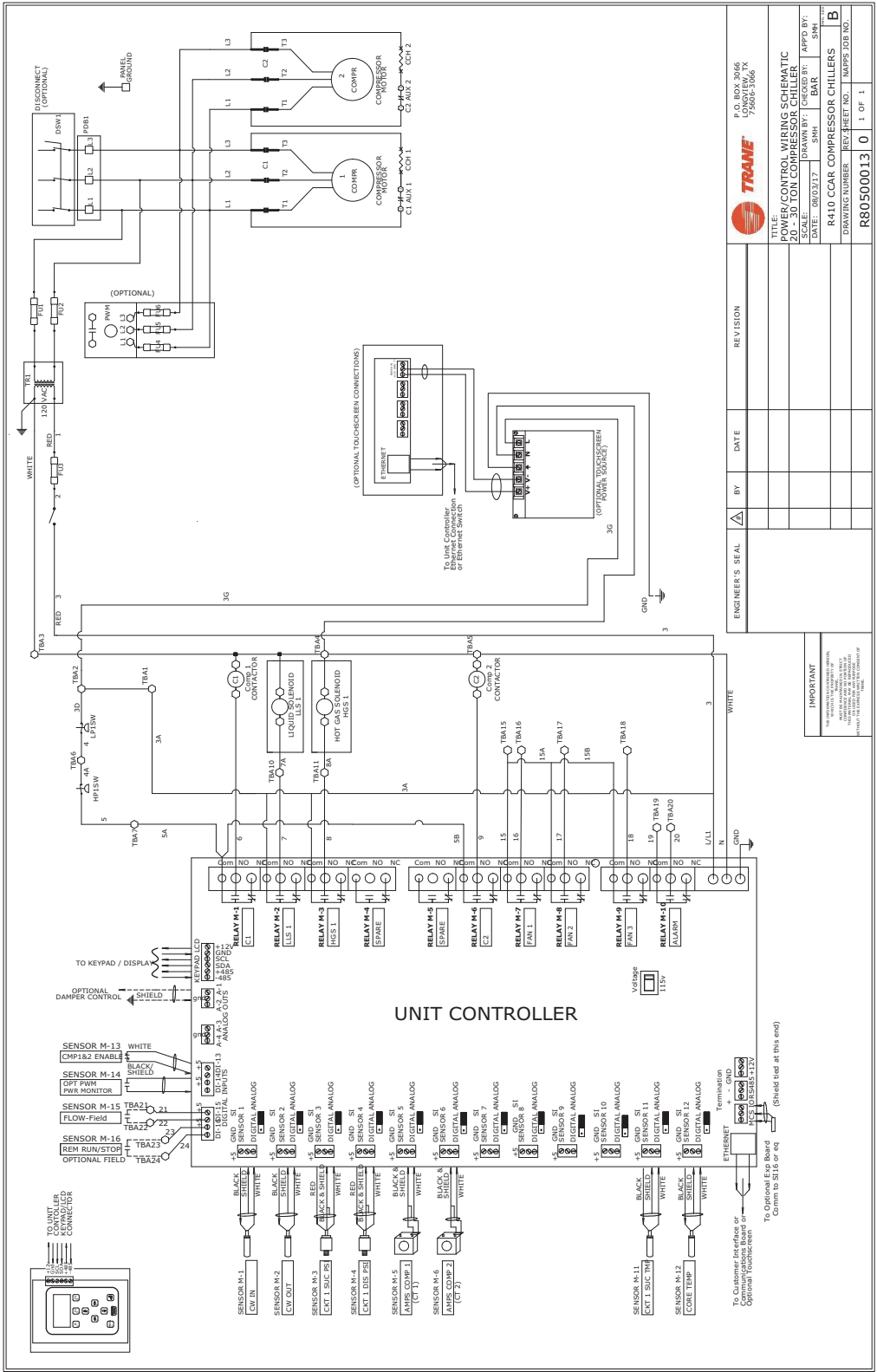
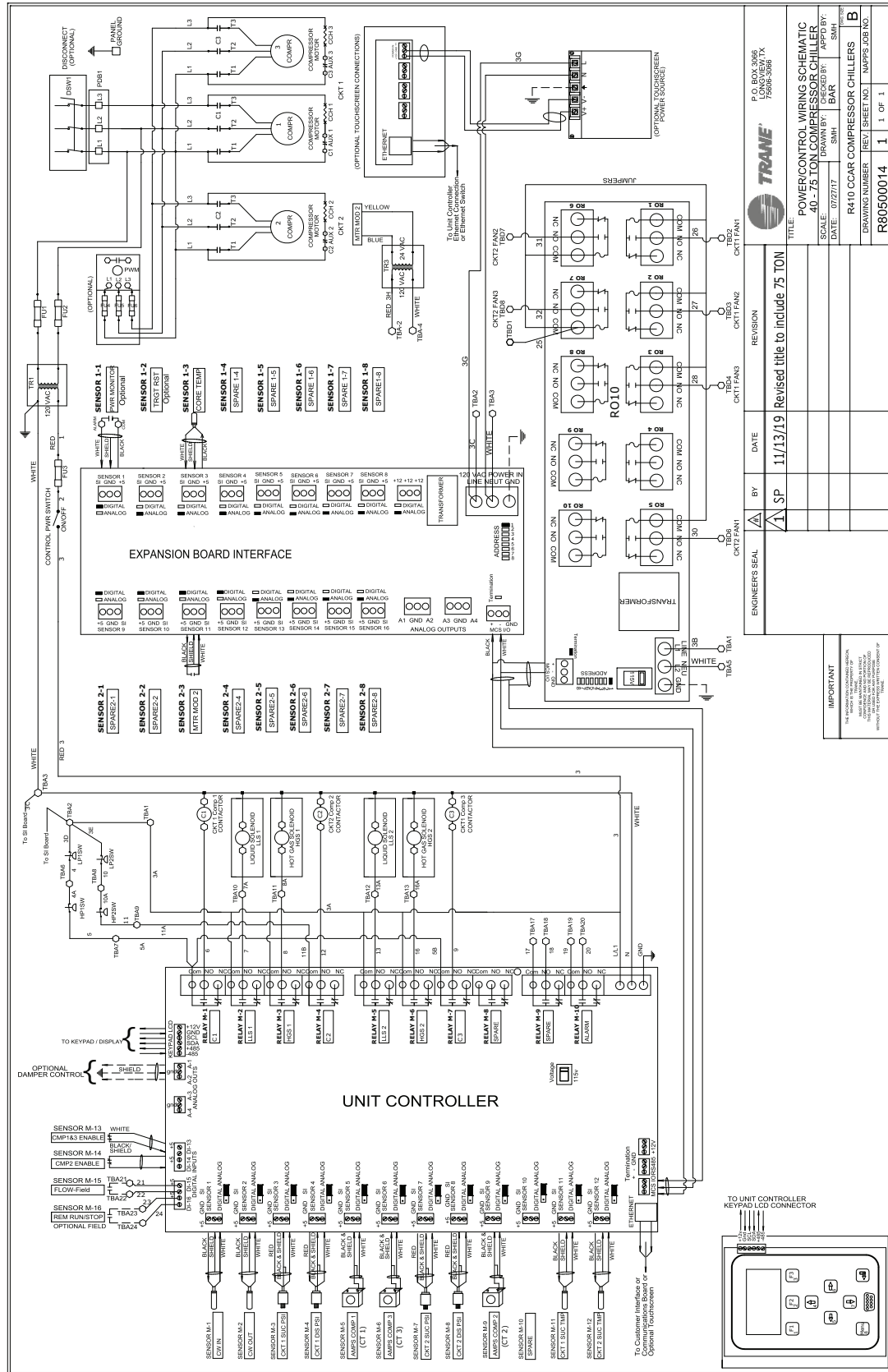


Figure 20. Power/control wiring schematic for 40 to 75 ton, R-410A CCAR compressor chillers



ENGINEER'S SEAL	DATE	BY	REVISION
	11/13/19	SP	Revised title to include 75 TON

P.O. BOX 3066 75066-3066	
TRANE	
TITLE: POWER/CONTROL WIRING SCHEMATIC 40- 75 TON CCAR COMPRESSOR CHILLERS	
SCALE:	DRAWN BY: SMH
DATE: 07/27/17	CHECKED BY: SMH
R410 CCAR COMPRESSOR CHILLERS	
DRAWING NUMBER:	REV: SHEET NO: MAPPS JOB NO:
R80500014	1 1 OF 1



Figure 21. Power schematic, CAUJ condenser control circuit modification: fan cycling control by CCAR compressor chillers

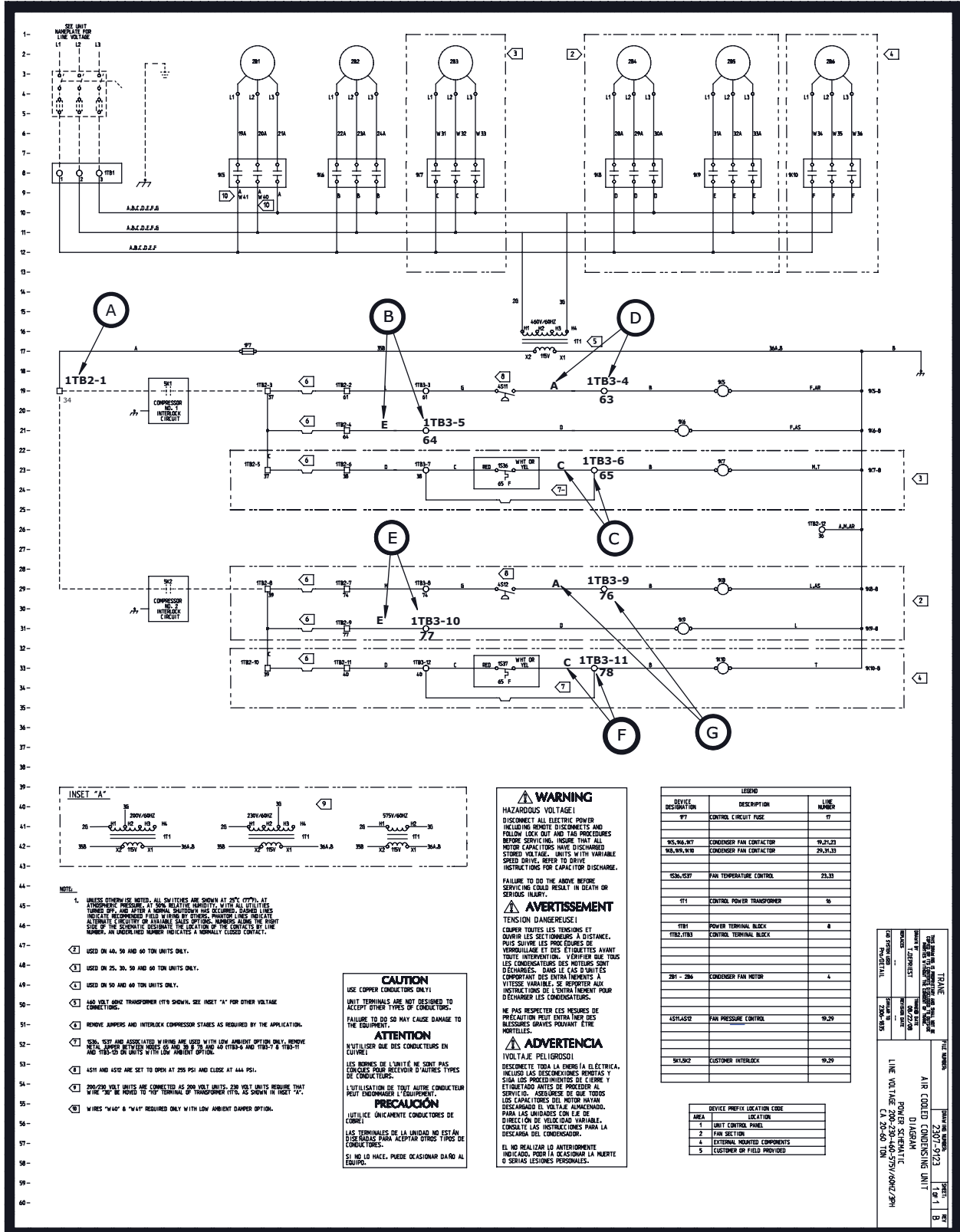


Figure 22. Instructions — CAUJ condenser control circuit modification: fan cycling control by CCAR compressor chillers

Trane CAUJ Condenser Control Wiring Modification Fan Cycling Control by Trane CCAR Compressor Chillers

FOR CONTROL OF 2 FAN CONDENSER:

Step	Reference Circle	Instructions	COMPLETE Initial/Date
1	(A)	Connect 1TB2-1 to TBA 15 at Trane Chiller.	
2	(B)	Remove wire 64E. Connect 1TB3-5 to TBA 16 at Trane Chiller. This is the first fan on and last fan off.	
3	(D)	Remove wire 63A. Connect 1TB3-4 to TBA 17 at Trane Chiller. This is the second fan on and first fan off. The installed pressure switch will not be used.	

FOR CONTROL OF 3 FAN CONDENSER:

Step	Reference Circle	Instructions	COMPLETE Initial/Date
1	(A)	Connect 1TB2-1 to TBA 15 at Trane Chiller.	
2	(B)	Remove wire 64E. Connect 1TB3-5 to TBA 16 at Trane Chiller. This is the first fan on and last fan off.	
3	(C)	Remove wire 65C and/or the jumper installed. Connect 1TB3-6 to TBA 17 at Trane Chiller. Ambient t-stat will not be used. This is the second fan on and second fan off.	
4	(D)	Remove wire 63A. Connect 1TB3-4 to TBA 18 at Trane Chiller. This is the last fan on and first fan off. The installed pressure switch will not be used.	

FOR CONTROL OF 4 FAN CONDENSER:

Step	Reference Circle	Instructions	COMPLETE Initial/Date
1	(A)	Connect 1TB2-1 to TBD 1 at Trane Chiller.	
2	(B)	Remove wire 64E. Connect 1TB3-5 to TBD 2 at Trane Chiller. This is the first fan on and last fan off.	
3	(D)	Remove wire 63A. Connect 1TB3-4 to TBD 3 at Trane Chiller. This is the last fan on and first fan off. The installed pressure switch will not be used.	
4	(E)	Remove wire 77E. Connect 1TB3-10 to TBD 6 at Trane Chiller. This is the first fan on and last fan off.	
5	(G)	Remove wire 76A. Connect 1TB3-9 to TBD 7 at Trane Chiller. This is the last fan on and first fan off. The installed pressure switch will not be used.	

FOR CONTROL OF 6 FAN CONDENSER:

Step	Reference Circle	Instructions	COMPLETE Initial/Date
1	(A)	Connect 1TB2-1 to TBD 1 at Trane Chiller.	
2	(B)	Remove wire 64E. Connect 1TB3-5 to TBD 2 at Trane Chiller. This is the first fan on and last fan off.	
3	(C)	Remove wire 65C and/or the jumper installed. Connect 1TB3-6 to TBD 3 at Trane Chiller. Ambient t-stat will not be used. This is the second fan on and second fan off.	
4	(D)	Remove wire 63A. Connect 1TB3-4 to TBD 4 at Trane Chiller. This is the last fan on and first fan off. The installed pressure switch will not be used.	
5	(E)	Remove wire 77E. Connect 1TB3-10 to TBD 6 at Trane Chiller. This is the first fan on and last fan off.	
6	(F)	Remove wire 78C and/or the jumper installed. Connect 1TB3-11 to TBD 7 at Trane Chiller. Ambient t-stat will not be used. This is the second fan on and second fan off.	
7	(G)	Remove wire 76A. Connect 1TB3-9 to TBD 8 at Trane Chiller. This is the last fan on and first fan off. The installed pressure switch will not be used.	

NOTES: All CCAR/CAUJ applications require that the CCAR Compressor Chiller control the condenser fan cycling. For Fan Cycling Control - One control wire for each condenser fan plus a common must be run from the CCAR Compressor Chiller to the CAUJ condenser. CCAR units are designed for operation down to a minimum of 40°F ambient.

PROPRIETARY AND CONFIDENTIAL
THE INFORMATION CONTAINED IN THIS DRAWING IS THE SOLE PROPERTY OF TRANE. ANY REPRODUCTION IN PART OR AS A WHOLE WITHOUT THE WRITTEN PERMISSION OF TRANE IS PROHIBITED.

DIMENSIONS ARE IN INCHES TOLERANCES: FRACTIONAL ± ANGULAR: MACH ± BEND ± TWO PLACE DECIMAL ± THREE PLACE DECIMAL ±	DRAWN: LAH 09/19/13 CHECKED: SMH 09/19/13 ENG APPR: EGN 09/19/13 MFG APPR: BAR 09/19/13	NAME: _____ DATE: _____ Q.A. _____ COMMENTS: _____
---	--	--

P.O. BOX 3066
LONGVIEW, TX
75606-3066

CAUJ Condenser Control
Wiring Modification:
Fan Cycling Control by CCAR
Compressor Chillers

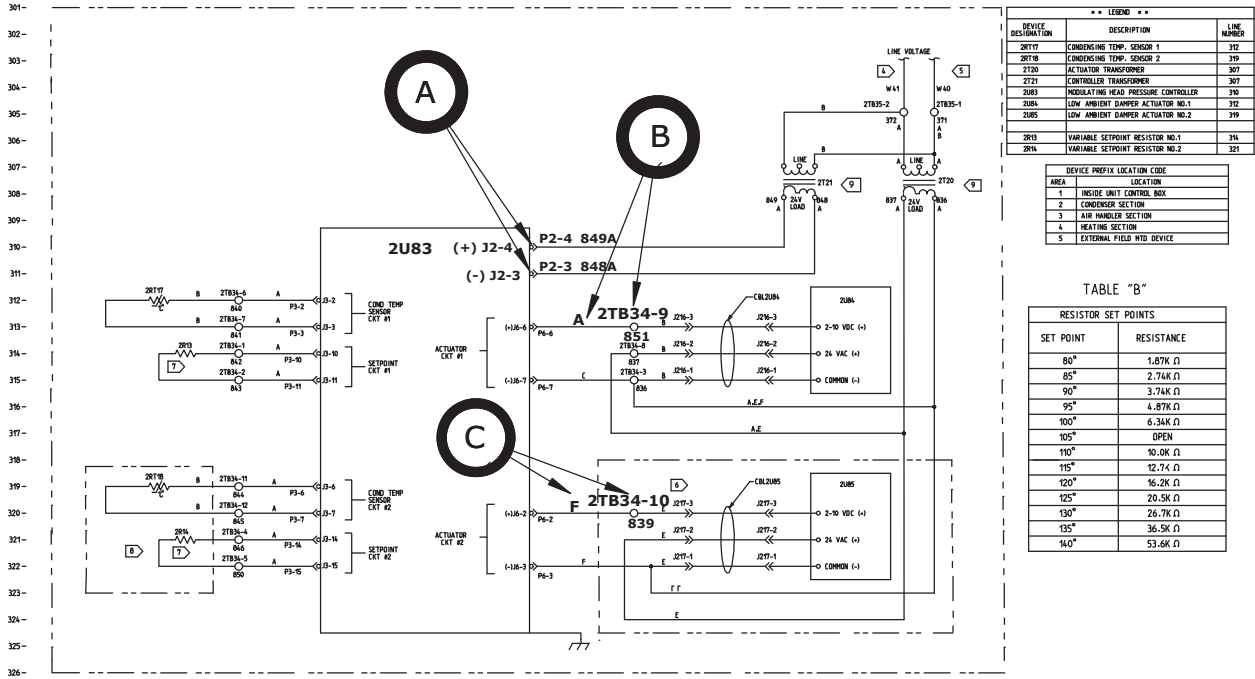
SIZE: A	DWG. NO.: R80500015B	REV.:
SCALE: 1:1	JOB #:	SHEET 1 OF 1

CG-SVX038E-EN

55

Figure 23. Low ambient damper schematic wiring and connections diagrams — CAUJ condenser control circuit modification: low ambient damper control by CCAR compressor chillers

Low Ambient Schematic Wiring Diagram



Low Ambient Connections Diagram

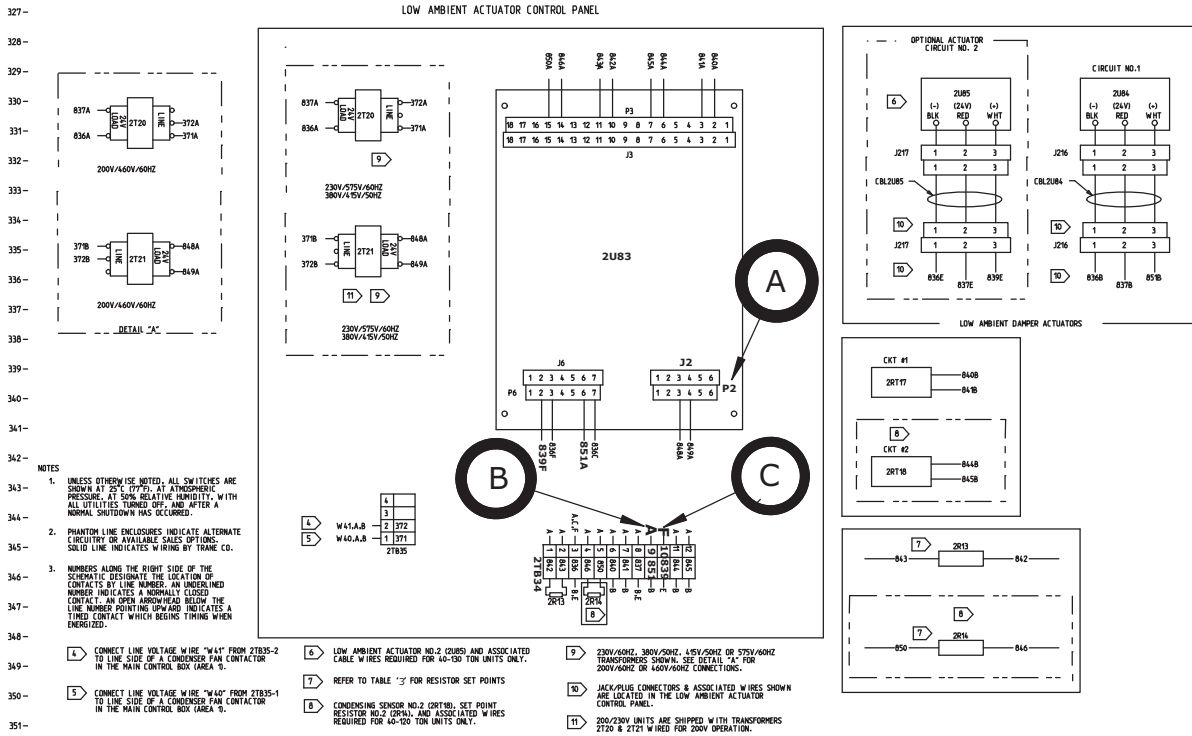
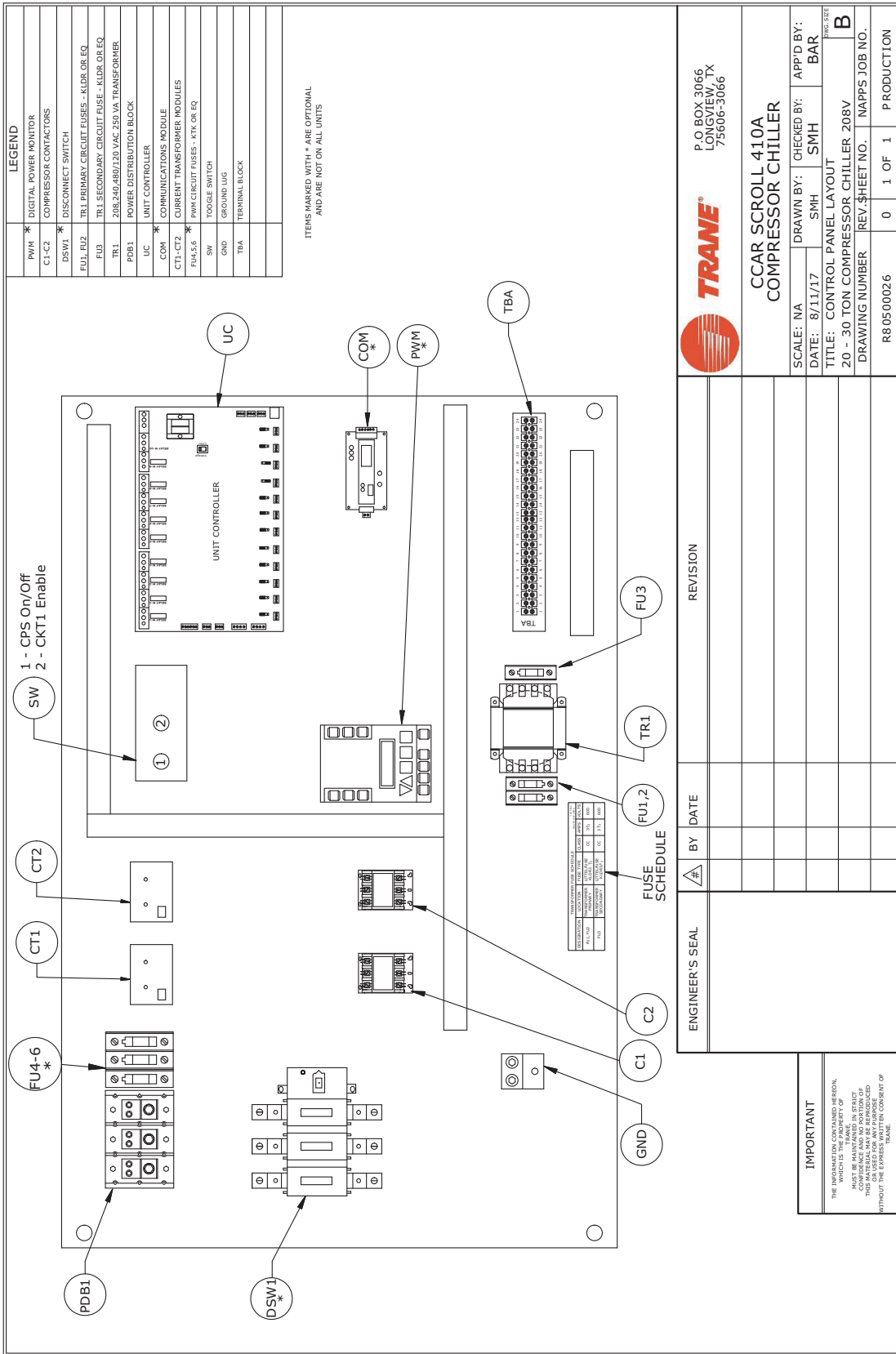


Figure 24. Instructions — CAUJ condenser control circuit modification: low ambient damper control by CCAR compressor chillers

Trane CAUJ Condenser Control Circuit Modification																																				
Ambient Damper Control by Trane CCAR Compressor Chiller																																				
FOR ONE DAMPER ASSEMBLY:																																				
Step	Reference Circle	Instructions	COMPLETE Initial/Date																																	
1	Ⓐ	Disconnect plug 2U83P2 from the existing damper control board. (Leave the remaining plugs connected to the board for grounding.)																																		
2	Ⓑ	Disconnect and tape wire 851A from 2TB34-9. Connect 0-10VDC signal from Trane chiller main board Analog Out (A-1) to 2TB34-9.																																		
FOR TWO DAMPER ASSEMBLIES:																																				
Step	Reference Circle	Instructions	COMPLETE Initial/Date																																	
1	Ⓐ	Disconnect plug 2U83P2 from the damper control box. (Leave the remaining plugs connected to the board for grounding.)																																		
2	Ⓑ	Disconnect and tape wire 851A from 2TB34-9. Connect 0-10VDC signal from Trane chiller main board Analog Out (A-1) to 2TB34-9.																																		
3	Ⓒ	Disconnect and tape wire 839F at 2TB34-10. Connect 0-10VDC signal from Trane chiller main board Analog Out (A-2) to 2TB34-10																																		
<p>NOTES: All CCAR/CAUJ applications require that the CCAR Compressor Chiller control the condenser ambient dampers (when applicable). For Ambient Control Dampers when applicable - One shielded pair for each damper assembly must be run from the CCAR Compressor Chiller to the CAUJ condenser. CCAR units are designed for operation down to a minimum of 40°F ambient.</p>																																				
<table border="1" style="width: 100%; border-collapse: collapse;"> <tr> <td rowspan="5" style="width: 20%; vertical-align: top;"> <p style="text-align: center; font-weight: bold; font-size: small;">PROPRIETARY AND CONFIDENTIAL</p> <p style="font-size: x-small;">THE INFORMATION CONTAINED IN THIS DRAWING IS THE SOLE PROPERTY OF TRANE. ANY REPRODUCTION IN PART OR AS A WHOLE WITHOUT THE WRITTEN PERMISSION OF TRANE IS PROHIBITED.</p> </td> <td style="width: 30%; font-size: x-small;"> DIMENSIONS ARE IN INCHES TOLERANCES: FRACTIONAL ± ANGULAR: MACH ± BEND ± TWO PLACE DECIMAL ± THREE PLACE DECIMAL ± </td> <td style="width: 20%; font-size: x-small;"> <table border="1" style="width: 100%; border-collapse: collapse;"> <tr> <th style="width: 10%;">NAME</th> <th style="width: 10%;">DATE</th> </tr> <tr> <td>DRAWN LAH</td> <td>09/19/13</td> </tr> <tr> <td>CHECKED SMH</td> <td>09/19/13</td> </tr> <tr> <td>ENG APPR. EGN</td> <td>09/19/13</td> </tr> <tr> <td>MFG APPR. BAR</td> <td>09/19/13</td> </tr> <tr> <td>Q.A.</td> <td></td> </tr> </table> </td> <td style="width: 20%; text-align: center; vertical-align: middle;"> </td> <td style="width: 30%; font-size: x-small;"> P.O. BOX 3066 LONGVIEW, TX 75606-3066 </td> </tr> <tr> <td style="font-size: x-small;">MATERIAL</td> <td style="font-size: x-small;">COMMENTS:</td> <td colspan="2" style="font-size: x-small;"> Trane CAUJ Condenser Control Circuit Modification: Ambient Damper Control by Trane CCAR Compressor Chiller </td> </tr> <tr> <td style="font-size: x-small;">FINISH</td> <td></td> <td style="font-size: x-small;"> SIZE A DWG. NO. R80500016B </td> <td style="font-size: x-small;">REV.</td> </tr> <tr> <td style="font-size: x-small;">DO NOT SCALE DRAWING</td> <td></td> <td style="font-size: x-small;">SCALE:1:1</td> <td style="font-size: x-small;">JOB #:</td> </tr> <tr> <td></td> <td></td> <td colspan="2" style="font-size: x-small;">SHEET 1 OF 1</td> </tr> </table>				<p style="text-align: center; font-weight: bold; font-size: small;">PROPRIETARY AND CONFIDENTIAL</p> <p style="font-size: x-small;">THE INFORMATION CONTAINED IN THIS DRAWING IS THE SOLE PROPERTY OF TRANE. ANY REPRODUCTION IN PART OR AS A WHOLE WITHOUT THE WRITTEN PERMISSION OF TRANE IS PROHIBITED.</p>	DIMENSIONS ARE IN INCHES TOLERANCES: FRACTIONAL ± ANGULAR: MACH ± BEND ± TWO PLACE DECIMAL ± THREE PLACE DECIMAL ±	<table border="1" style="width: 100%; border-collapse: collapse;"> <tr> <th style="width: 10%;">NAME</th> <th style="width: 10%;">DATE</th> </tr> <tr> <td>DRAWN LAH</td> <td>09/19/13</td> </tr> <tr> <td>CHECKED SMH</td> <td>09/19/13</td> </tr> <tr> <td>ENG APPR. EGN</td> <td>09/19/13</td> </tr> <tr> <td>MFG APPR. BAR</td> <td>09/19/13</td> </tr> <tr> <td>Q.A.</td> <td></td> </tr> </table>	NAME	DATE	DRAWN LAH	09/19/13	CHECKED SMH	09/19/13	ENG APPR. EGN	09/19/13	MFG APPR. BAR	09/19/13	Q.A.			P.O. BOX 3066 LONGVIEW, TX 75606-3066	MATERIAL	COMMENTS:	Trane CAUJ Condenser Control Circuit Modification: Ambient Damper Control by Trane CCAR Compressor Chiller		FINISH		SIZE A DWG. NO. R80500016B	REV.	DO NOT SCALE DRAWING		SCALE:1:1	JOB #:			SHEET 1 OF 1	
<p style="text-align: center; font-weight: bold; font-size: small;">PROPRIETARY AND CONFIDENTIAL</p> <p style="font-size: x-small;">THE INFORMATION CONTAINED IN THIS DRAWING IS THE SOLE PROPERTY OF TRANE. ANY REPRODUCTION IN PART OR AS A WHOLE WITHOUT THE WRITTEN PERMISSION OF TRANE IS PROHIBITED.</p>	DIMENSIONS ARE IN INCHES TOLERANCES: FRACTIONAL ± ANGULAR: MACH ± BEND ± TWO PLACE DECIMAL ± THREE PLACE DECIMAL ±	<table border="1" style="width: 100%; border-collapse: collapse;"> <tr> <th style="width: 10%;">NAME</th> <th style="width: 10%;">DATE</th> </tr> <tr> <td>DRAWN LAH</td> <td>09/19/13</td> </tr> <tr> <td>CHECKED SMH</td> <td>09/19/13</td> </tr> <tr> <td>ENG APPR. EGN</td> <td>09/19/13</td> </tr> <tr> <td>MFG APPR. BAR</td> <td>09/19/13</td> </tr> <tr> <td>Q.A.</td> <td></td> </tr> </table>	NAME		DATE	DRAWN LAH	09/19/13	CHECKED SMH	09/19/13	ENG APPR. EGN	09/19/13	MFG APPR. BAR	09/19/13	Q.A.			P.O. BOX 3066 LONGVIEW, TX 75606-3066																			
	NAME	DATE																																		
	DRAWN LAH	09/19/13																																		
	CHECKED SMH	09/19/13																																		
	ENG APPR. EGN	09/19/13																																		
MFG APPR. BAR	09/19/13																																			
Q.A.																																				
MATERIAL	COMMENTS:	Trane CAUJ Condenser Control Circuit Modification: Ambient Damper Control by Trane CCAR Compressor Chiller																																		
FINISH		SIZE A DWG. NO. R80500016B	REV.																																	
DO NOT SCALE DRAWING		SCALE:1:1	JOB #:																																	
		SHEET 1 OF 1																																		

Figure 25. Control panel layout for 20 to 30 ton, 208V, R-410A CCAR compressor chillers



TRANE

P.O. BOX 3066
LONGVIEW, TX
75606-3066

**CCAR SCROLL 410A
COMPRESSOR CHILLER**

SCALE: NA DRAWN BY: SMH CHECKED BY: SMH APP'D BY: BAR
DATE: 8/11/17 REV. SHEET NO.: B
DRAWING NUMBER: R8 05 00026 REV. SHEET NO.: 0 1 OF 1 PRODUCTION

ENGINEER'S SEAL	BY	DATE	REVISION

IMPORTANT

THE INFORMATION CONTAINED HEREIN,
WHICH IS THE PROPERTY OF
TRANE, IS UNCLASSIFIED
EXCEPT WHERE SHOWN
OTHERWISE. THIS MATERIAL
MAY BE REPRODUCED
WITHOUT THE EXPRESS WRITTEN CONSENT OF
TRANE.

Figure 26. Control panel layout for 20 to 30 ton, 460V, R-410A CCAR compressor chillers

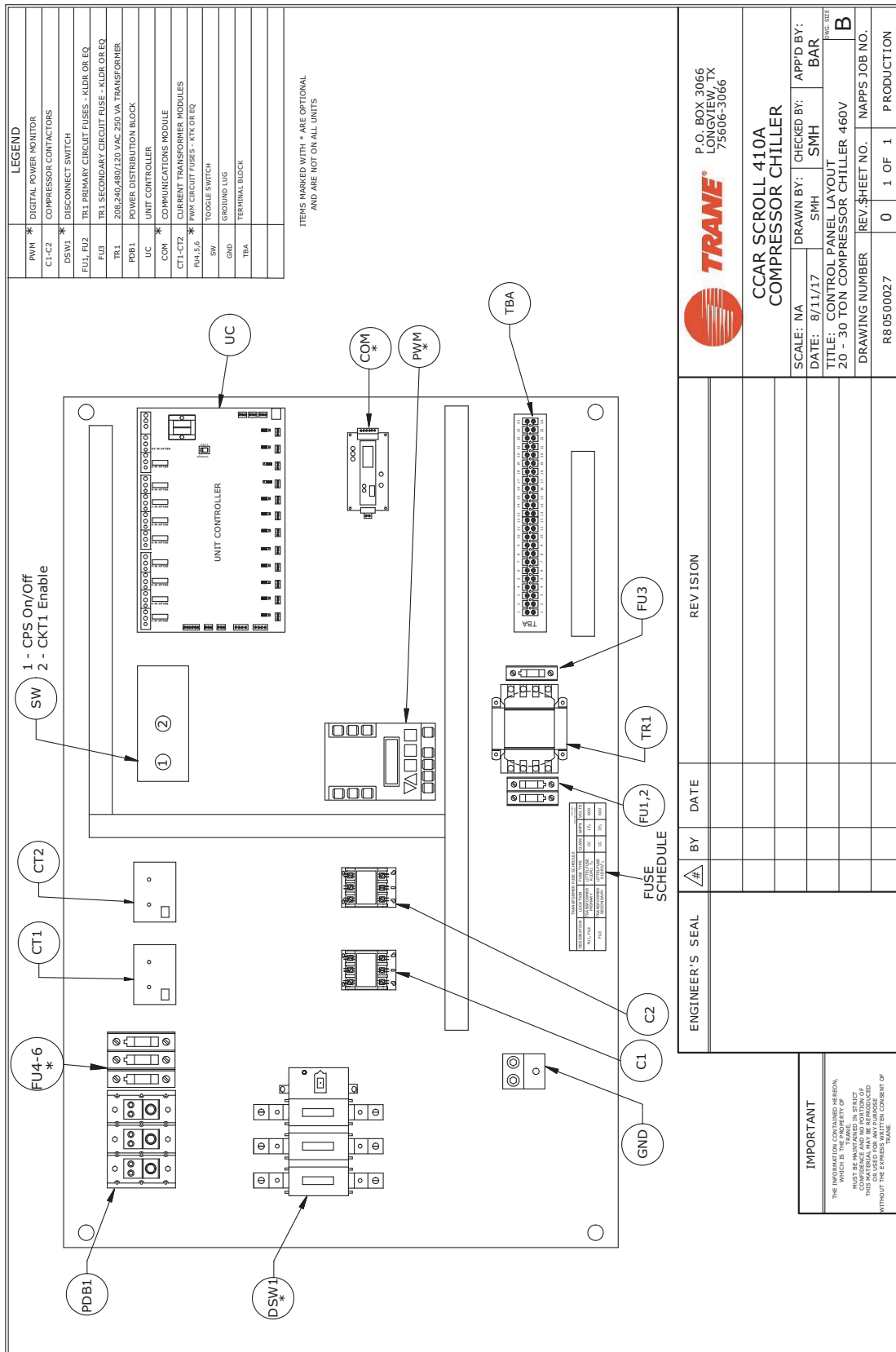


Figure 27. Control panel layout for 20 to 30 ton, 575V, R-410A CCAR compressor chillers

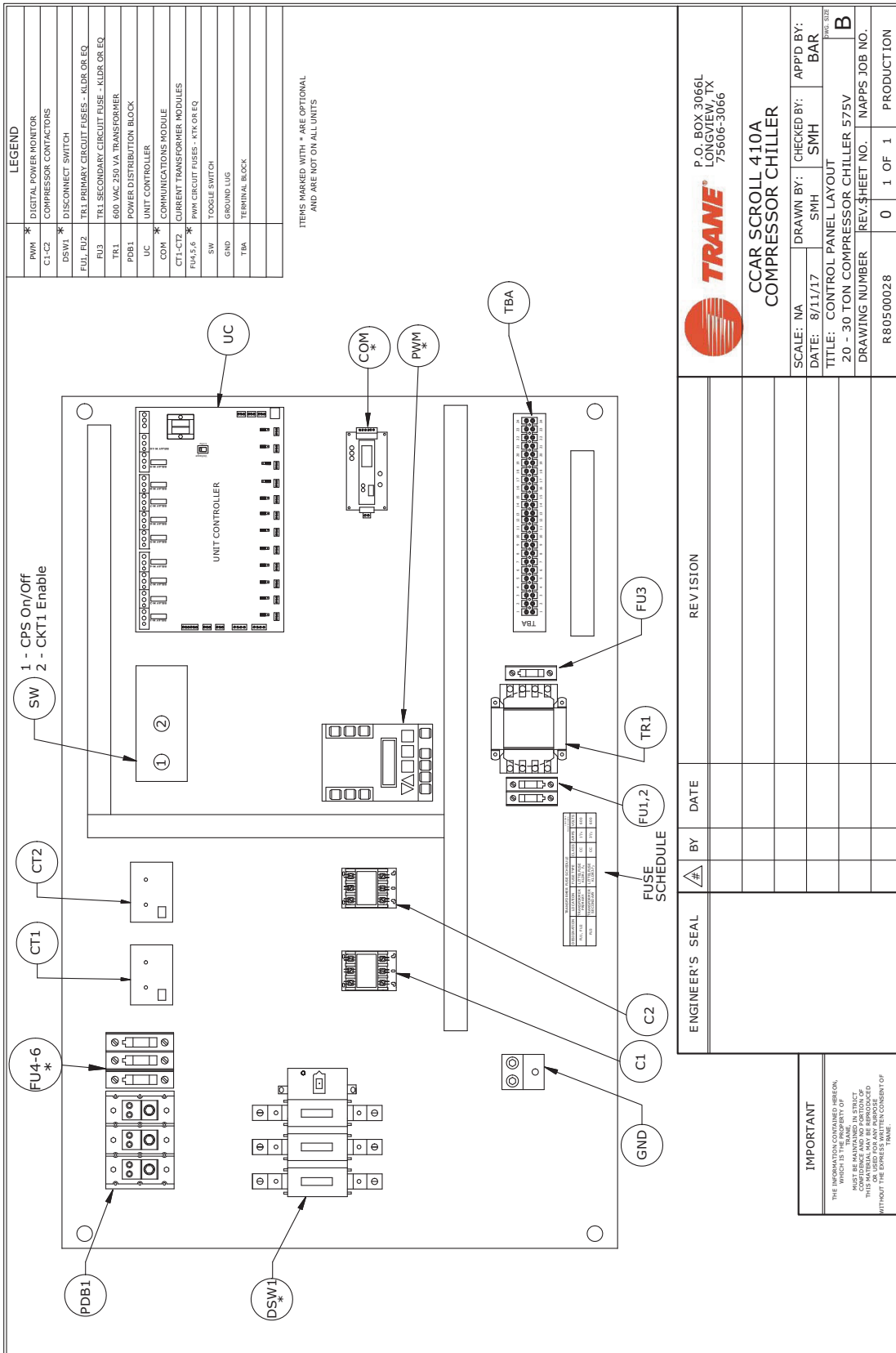


Figure 28. Control panel layout for 40 to 75 ton, 208V, R-410A CCAR compressor chillers

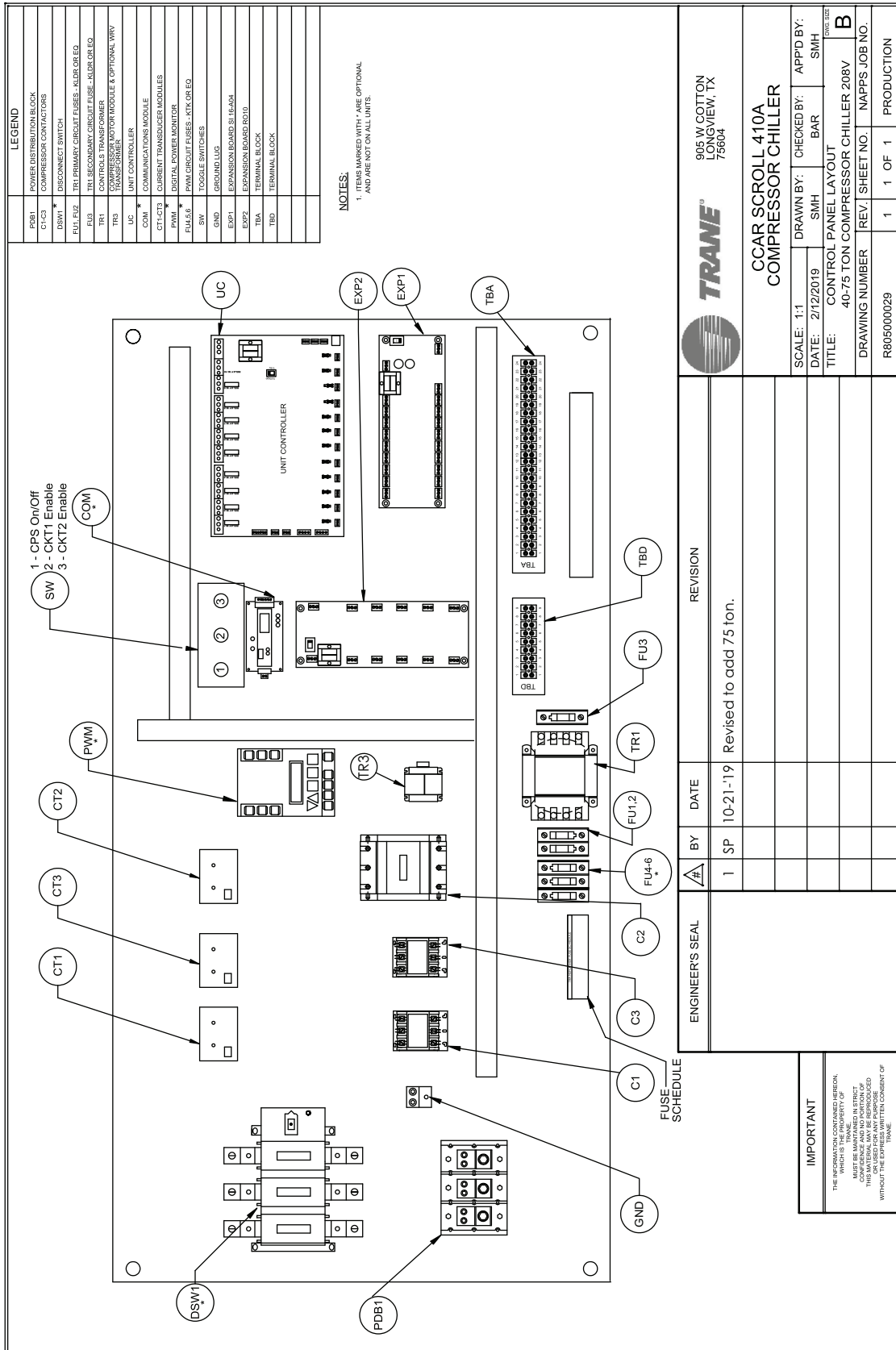


Figure 29. Control panel layout for 40 to 75 ton, 460V, R-410A CCAR compressor chillers

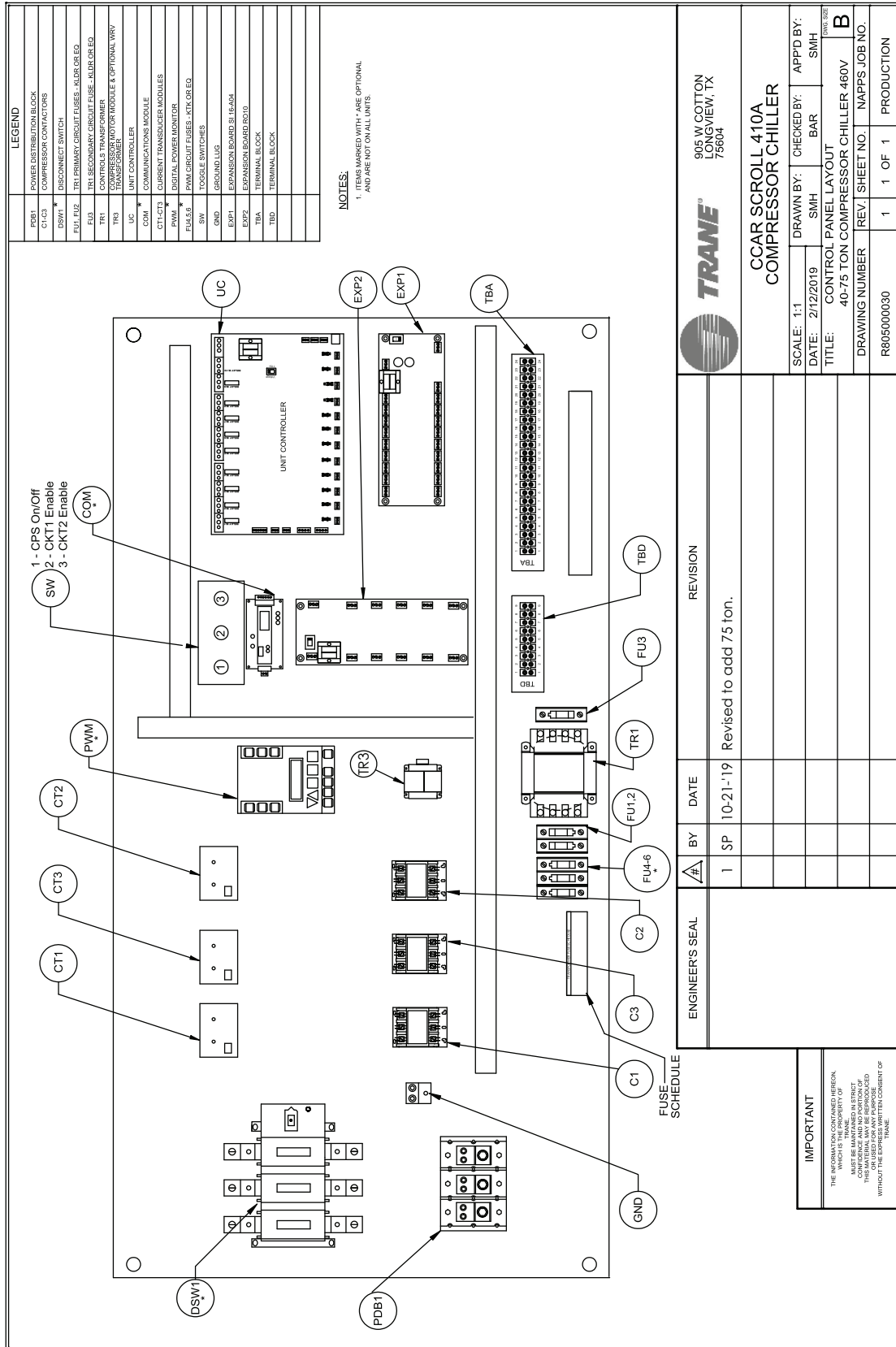
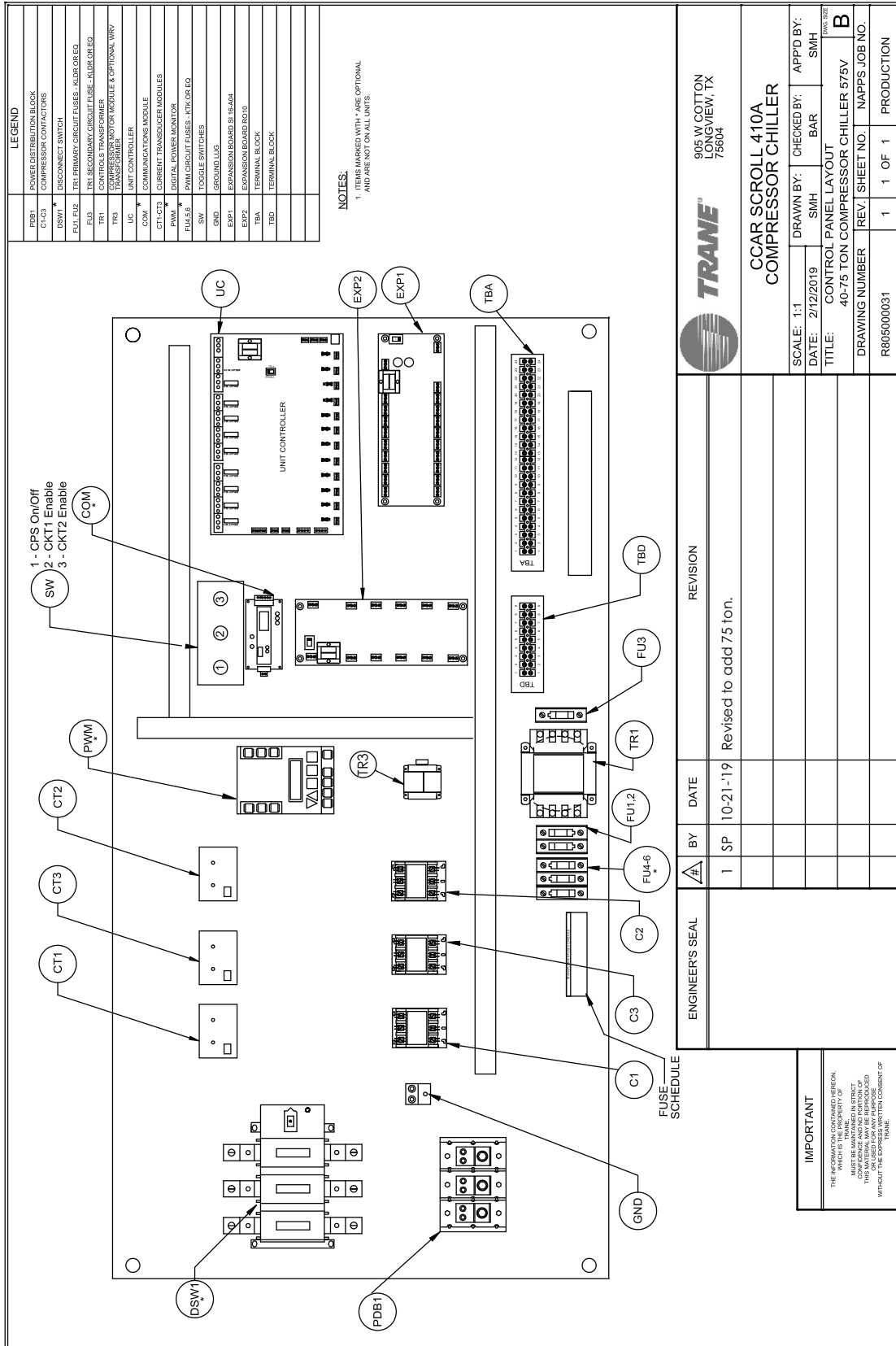


Figure 30. Control panel layout for 40 to 75 ton, 575V, R-410A CCAR compressor chillers



Appendix

Vendor Data Sheet

MCS-CT300 Current Transducer Data Sheet



MCS-CT300

Description & Specifications



Part # **MCS-CT300**



Specifications

Dimensions:

Height	4.00"
Width	2.38"
Depth	1.56"
Wire Hole	1.00"

Amperage Rating.....	0-300A
Accuracy.....	± 3 amps
Sensor Output Voltage	0-5vdc
Supply Voltage.....	Induced

Operating Temperature	-40°F to +158°F (-40°C to +70°C)
Storage Temperature.....	-40°F to +158°F (-40°C to +70°C)

Description

The **MCS-CT300** current sensor monitors current flowing to electrical equipment. The magnitude of the current is converted to a linear 0 to 5vdc output signal which can be read as a standard analog input signal. The signal is used by MCS micro controllers for the following:

1. For slide valve positioning on screw machines
2. For high amp motor overload protection
3. For verification of device on / off
4. Used in kw calculations

The MCS-CT300 is a solid-core version, so the conductor runs through the sensor. No cutting, taping or rerouting is required. It is accurate, reliable, easy to install and requires no service.

The MCS-CT300 has an accuracy of ± 3 amps in the frequency range from 50-60Hz. The sensor outputs a 0 to 5vdc signal. The sensor power is induced from the current being monitored.

On the printed circuit board, a resistor is mounted across the CT terminals, which eliminates danger from induced current. A removable three-position terminal block is provided for easy wiring.

A two-conductor shielded cable must be used. The shield must be cut at the MCS-CT300 end and tied to ground at the MCS micro controller terminal block.

Amps	Volts dc
10	0.13
20	0.30
30	0.48
40	0.65
50	0.82
60	0.99
70	1.16
80	1.34
90	1.51
100	1.68
110	1.85
120	2.02
130	2.19
140	2.36
150	2.53

Amps	Volts dc
160	2.71
170	2.88
180	3.05
190	3.22
200	3.39
210	3.56
220	3.73
230	3.91
240	4.06
250	4.23
260	4.40
270	4.58
280	4.74
290	4.91
300	5.08

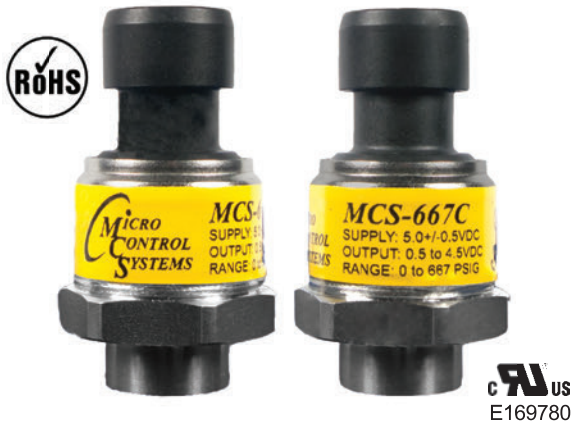
Revision 2015-08-07

5580 Enterprise Pkwy., Fort Myers, FL 33905
Office: 239-694-0089 • Fax: 239-694-0031 www.mcscontrols.com

MCS-667C Pressure Transducer Data Sheet


MCS-667C-xx*

Description & Specifications



Part # **MCS-667C-xx***

Description

The **MCS-667C** pressure transducer is specially designed for use in HVAC/refrigeration applications, in the most demanding environments, where low cost is needed yet maintaining high accuracy, long term reliability, and long life.

Features include, high accuracy, wide temperature range, refrigerant media compatibility and rugged design for outdoor use.

The MCS-667C pressure transducer is UL and RoHS compliant. It is capable of surviving high vibration. MCS-667C is a sealed gage pressure transducer with a cavity built out of stainless steel with a rugged sealing material for outdoor environments, 1/4" SAE Female Flare fitting & Schrader valve; 7/16-20 UNF pipe thread which creates a leak-proof, all metal sealed system that makes the MCS-667C ideal for use with rugged HVAC environments using refrigerant Media.

Specifications

- Pressure Range.....0 to 667 psi (sealed gauge)
- Housing304L stainless steel
- Sealing Material.....Rugged seal ideal for outdoor environments
- Electrical Connection.....IP67
- Operating Temperature....-40°C to 125°C (-40°F to 257°F)
- Storage Temperature.....-40°C to 150°C (-40°F to 302°F)
- Accuracy.....± 1% F.S. typical over -25°C to 125°C (-13°F to 257°F)
- Agency Approvals.....UL873, ROHS compliant
- Proof Pressure.....1000 psi, 6.9 MPa
- Burst Pressure.....3600 psi, 24.8 MPa
- Vibration11 g (50 to 2000 Hz)
- Supply Voltage5.0Vdc +/-0.5, max 10 mA
- Output Voltage0.5 VDC to 4.5 VDC typical
- Supply Current.....8 mA max @ 5 VDC with no load
- Output Current.....2.5 mA max sink or source
- Connection1/4" SAE Female Flare fitting & Schrader valve; 7/16-20 UNF thread

*Optional Cable:

MCS-667C Transducer is available with an optional cable as shown below, please specify the length needed:

Replace -xx with: 20' 40' or 60' wire length.



NOTE: IF -XX IS OMITTED, MCS-667C TRANSDUCER IS SHIPPED WITHOUT THE OPTIONAL CABLE.

The cable has a removable Packard connector to provide easy serviceability. The wire is sealed and crimped to the Packard connector providing a liquid tight environment and strain relief.



- Connector.....Packard with Silicone seal
- Length.....20', 40' or 60' feet
- Type.....3-conductor, 20 awg stranded
- Shield.....Foil shield with 25% overlap
- Drain.....Stranded tinned copper drain

PSI to VDC

PSI	SI (vdc)	PSI	SI (vdc)	PSI	SI (vdc)	PSI	SI (vdc)	PSI	SI (vdc)	PSI	SI (vdc)	PSI	SI (vdc)
0	0.50	100	1.10	200	1.70	300	2.30	400	2.90	500	3.50	600	4.10
10	0.56	110	1.16	210	1.76	310	2.36	410	2.96	510	3.56	610	4.16
20	0.62	120	1.22	220	1.82	320	2.42	420	3.02	520	3.62	620	4.22
30	0.68	130	1.28	230	1.88	330	2.48	430	3.08	530	3.68	630	4.28
40	0.74	140	1.34	240	1.94	340	2.54	440	3.14	540	3.74	640	4.34
50	0.80	150	1.40	250	2.00	350	2.60	450	3.20	550	3.80	650	4.40
60	0.86	160	1.46	260	2.06	360	2.66	460	3.26	560	3.86	660	4.46
70	0.92	170	1.52	270	2.12	370	2.72	470	3.32	570	3.92	667	4.50
80	0.98	180	1.58	280	2.18	380	2.78	480	3.38	580	3.98		
90	1.04	190	1.64	290	2.24	390	2.84	490	3.44	590	4.04		

Revision - 2019-07-02

5880 Enterprise Pkwy., Fort Myers, FL 33905
Office: 239-694-0089 • Fax: 239-694-0031 www.mcscontrols.com

The MCS-T100 Specifications and Description



MCS-T100 Description & Specifications



Part # MCS-T100



Description

The MCS-T100 is an extremely fast acting temperature sensor built for demanding environments. It is ideal for high moisture locations with continuous freeze and thaw cycles. The sensor is potted with a thermally conductive RTV Cure Silicon Adhesive to guarantee durability and response. Its high accuracy allows for interchangeability in the field. The large resistance range allows the use of over 1000' of cable with no noticeable effect. By placing a 100,000 ohm resistor between signal and ground the sensor may be used in a three wire input mode. The table below provides a cross reference between °F / °C, ohms, and vdc at a sensor input pin (S1) of a MCS micro controller.

Specifications

Standard Temperature Range.....+32°F to +158°F (0°C to +70°C)
 Standard Temperature Accuracy .. ±0.36°F (±0.2°C)
 Extended Temperature Range..... -40°F to +248°F
 (-40°C to 120°C)
 Extended Temperature Accuracy.. ±1.5°F (±0.8°C)
 Resistance Range 4 Megohms to 3K ohms
 Response Time (32 to 212°F)..... 22 sec (in liquid)
 Response Time (212 to 32°F)..... 30 sec (in liquid)
 Input Voltage..... 5vdc
 Sensor Resistance 100,000 ohms @ 77°F (25°C)

Housing Specifications:

Dimensions..... 0.187"OD x 1.5"L
 Material..... Stainless Steel
 Environmental rating..... Waterproof to IP68
 Testing 10,000 freeze/thaw thermal cycles

Cable:

Length..... 20', 40', 60', 100' and 150'
 Wire 2 conductor 22 awg stranded
 Shield..... Foil shield with 25% overlap
 Drain Stranded tinned copper drain

Part number description when ordering (MCS-T100-xx)

xx..... 20', 40', 60', 100' or 150'
 wire length

Temperature to Resistance to VDC Chart

Temp (°F / °C)	Resist (ohms)	S1 (vdc)	Temp (°F / °C)	Resist (ohms)	S1 (vdc)	Temp (°F / °C)	Resist (ohms)	S1 (vdc)	Temp (°F / °C)	Resist (ohms)	S1 (vdc)	Temp (°F / °C)	Resist (ohms)	S1 (vdc)
-40/-40	4,015,500	0.121	32/0	351,020	1.109	95/35	63,480	3.058	158/70	15,500	4.329	208/97.7	5,981	4.718
-35/-37.2	3,324,096	0.146	35/1.6	320,976	1.188	100/37.7	56,200	3.201	160/71.1	14,881	4.352	210/98.8	5,773	4.727
-30/-34.4	2,760,524	0.175	38/3.3	293,758	1.270	104/40	51,050	3.310	165/73.8	13,456	4.407	212/100	5,573	4.736
-25/-31.6	2,299,670	0.208	40/4.4	277,040	1.326	105/40.5	49,846	3.337	167/75	12,930	4.428	215/101.6	5,289	4.749
-20/-28.9	1,921,640	0.247	45/7.2	239,686	1.472	110/43.3	44,287	3.465	170/76.6	12,185	4.457	218/103.3	5,020	4.761
-15/-26.1	1,610,592	0.292	50/10	207,850	1.624	113/45	41,290	3.539	175/79.4	11,052	4.502	220/104.4	4,849	4.769
-10/-23.3	1,353,866	0.344	55/12.7	180,647	1.782	115/46.1	39,420	3.586	180/82.2	10,033	4.544	223/106.1	4,605	4.780
-5/-20.6	1,141,345	0.403	58/14.4	166,243	1.878	120/48.8	35,149	3.697	183/83.8	9,474	4.567	225/107.2	4,449	4.787
0 /-17.7	964,963	0.470	60/15.5	157,353	1.943	125/51.6	31,399	3.805	185/85	9,121	4.582	227/108.3	4,299	4.794
5/-15.0	818,070	0.545	65/18.3	137,363	2.106	130/54.4	28,093	3.903	190/87.7	8,303	4.617	230/110	4,085	4.804
10/-12.2	695,433	0.629	70/21.1	120,169	2.271	135/57.2	25,173	3.994	195/90.5	7,567	4.648	233/111.6	3,886	4.813
15 /-9.4	592,755	0.722	75/23.9	105,347	2.435	140/60	22,590	4.079	198/92.2	7,162	4.666	235/112.7	3,760	4.819
20/-6.6	506,560	0.824	80/26.7	92,541	2.597	145/62.8	20,309	4.156	200/93.3	6,906	4.677	240/115.5	3,463	4.833
25/-3.8	434,007	0.936	85/29.4	81,454	2.756	150/65.5	18,284	4.227	203/95	6,541	4.693	245/118.3	3,191	4.845
30/-1.1	372,778	1.058	90/32.2	71,838	2.910	155/68.3	16,484	4.292	205/96.1	6,310	4.703	248/120	3,040	4.852

5580 Enterprise Pkwy., Fort Myers, FL 33905
 Office: 239-694-0089 • Fax: 239-694-0031 www.mcscontrols.com

Warranty

I. Limited Product Warranty and Service Policy

Napps Technology Corporation (NTC) warrants for a period of twelve (12) months from date of original shipment that all products, manufactured by NTC, with the exception of packaged refrigeration products, are free from defects of material and workmanship when used within the service, range, and purpose for which they were manufactured. Packaged refrigeration products shall be so warranted for a period of twelve (12) months from date of start-up or eighteen (18) months from date of original shipment, whichever may first occur. Service Parts shall be so warranted for a period of ninety (90) days from date of installation, or twelve (12) months from date of original shipment, whichever may first occur.

In case material is rejected on inspection by the buyer as defective, NTC shall be notified in writing within ten (10) days from receipt of said material. NTC will then have the option of re-inspection at the buyer's plant or its own plant before allowing or rejecting the buyer's claim. Expenses incurred in connection with claims for which NTC is not liable may be charged back to the buyer. No claim for correction will be allowed for work done in the field except with the written consent of NTC. Defects that do not impair service shall not be cause for rejection. NTC assumes no liability in any event for consequential damages. No claim will be allowed for material damaged by the buyer or in transit. Defective equipment or parts shall be returned to NTC freight prepaid.

NTC will, at its option, repair, replace or refund the purchase price of products found by NTC to be defective in material or workmanship provided that written notice of such defect requesting instruction for repair, replacement or refund is received by NTC within ten (10) days of determination of said defect, but not more than one (1) year after the date of shipment, and provided that any instructions given thereafter by NTC are followed.

Any products covered by this order found to NTC satisfaction to be defective upon examination at NTC factory will, at NTC option, be repaired or replaced and returned to Buyer via lowest cost common carrier, or NTC may, at its option, grant Buyer a credit for the purchase price of the defective article.

This warranty does not cover and does not apply to:

1. Fuses, refrigerant, fluids, oil;
2. Products relocated after initial installation;
3. Any portion or component of the system that is not supplied by NTC, regardless of the cause of the failure of such portion or component;
4. Products on which the units identification tags or labels have been removed or defaced;
5. Products on which payment to NTC is or has been in default;
6. Products which have defects or damage which result from improper installation, wiring, electrical imbalance characteristics or maintenance (including, without

limitation, defects or damages caused by voltage surges, inadequate voltage conditions, phase imbalance, any form of electrical disturbances, inadequate or improper electrical circuit installation or protection, failure to perform common maintenance, etc.); or are caused by accident, misuse or abuse, fire, the elements, shock, vibration, flood, alteration, misapplication of the product or to any other service, range or environment of greater severity than that for which the products were designed;

7. Products which have defects or damage which result from a contaminated or corrosive air or liquid supply, operation at abnormal temperatures, or unauthorized opening of refrigerant circuit;
8. Products subjected to corrosion or abrasion or chemicals;
9. Mold, fungus or bacteria damage;
10. Products manufactured or supplied by others;
11. Products which have been subjected to misuse, negligence, vandalism or accidents;
12. Products which have been operated in a manner contrary to NTC printed instructions;
13. Products which have defects, damage or insufficient performance as a result of insufficient or incorrect system design or the improper application of NTC products;
14. Products which have defects or damages due to freezing of the water supply, an inadequate or interrupted water supply, corrosives or abrasives in the water supply, or improper or inadequate filtration or treatment of the water or air supply.
15. Water-to-refrigerant heat exchanger for any damage resulting from freezing, fouling, corrosion or clogging.

NTC is not responsible for:

1. The costs of any fluids, oils refrigerant or other system components, or the associated labor to repair or replace the same, which is incurred as a result of a defective part covered by NTC Limited Product Warranty;
2. The costs of labor, refrigerant, materials or service incurred in removal of the defective part, or in obtaining and replacing the new or repaired part; or,
3. Transportation costs of the defective part from the installation site to NTC or the return of any part not covered by NTC Limited Product Warranty.



Appendix

THE WARRANTY PROVIDED ABOVE IS THE ONLY WARRANTY MADE BY NTC WITH RESPECT TO ITS PRODUCTS OR ANY PARTS THEREFORE AND IS MADE EXPRESSLY IN LIEU OF ANY OTHER WARRANTIES, BY COURSE OF DEALING, USAGES OF TRADE OR OTHERWISE, EXPRESSED OR IMPLIED, INCLUDING BUT NOT LIMITED TO ANY IMPLIED WARRANTIES OF FITNESS FOR ANY PARTICULAR PURPOSE OR OF MERCHANTABILITY UNDER THE UNIFORM COMMERCIAL CODE. IT IS AGREED THAT THIS WARRANTY IS IN LIEU OF AND BUYER HEREBY WAIVES ALL OTHER WARRANTIES, GUARANTEES OR LIABILITIES ARISING BY LAW OR OTHERWISE. NTC SHALL NOT INCUR ANY OTHER, OBLIGATIONS OR LIABILITIES OR BE LIABLE TO BUYER OR ANY CUSTOMER OF BUYER FOR ANY ANTICIPATED OR LOST PROFITS, INCIDENTAL OR CONSEQUENTIAL DAMAGES, OR ANY OTHER LOSSES OR EXPENSES INCURRED BY REASON OF THE PURCHASE, INSTALLATION, REPAIR, USE OR MISUSE BY BUYER OR THIRD PARTIES OF ITS PRODUCTS (INCLUDING ANY PARTS REPAIRED OR REPLACED); AND NTC DOES NOT AUTHORIZE ANY PERSON TO ASSUME FOR NTC ANY OTHER LIABILITY IN CONNECTION WITH THE PRODUCTS OR PARTS THEREFORE. NTC SHALL NOT BE RESPONSIBLE FOR THE LOSS OR REPLACEMENT OF OR THE ADDITION OF COMPRESSOR OIL, OR REFRIGERANT. THIS WARRANTY CANNOT BE EXTENDED, ALTERED OR VARIED EXCEPT BY A WRITTEN INSTRUMENT SIGNED BY NTC AND BUYER.

II. Limitation Of Liability

NTC shall not be liable, in contract or in tort, for any special, indirect, incidental or consequential damages, such as, but not limited to, loss of profits, or injury or damage caused to property, products, or persons by reason of the installation, modification, use, repair, maintenance or mechanical failure of any NTC product.



Notes

Trane - by Trane Technologies (NYSE: TT), a global climate innovator - creates comfortable, energy efficient indoor environments for commercial and residential applications. For more information, please visit trane.com or tranetechnologies.com.

Trane has a policy of continuous product and product data improvement and reserves the right to change design and specifications without notice. We are committed to using environmentally conscious print practices.