



Installation, Operation, and Maintenance

IntelliCore™ Split System

Air-Cooled Condensers — 20 to 120 Tons



Model Numbers: CAUK-C20 CAUK-C60
CAUK-C25 CAUK-C80
CAUK-C30 CAUK-D10
CAUK-C40 CAUK-D12
CAUK-C50

▲ SAFETY WARNING

Only qualified personnel should install and service the equipment. The installation, starting up, and servicing of heating, ventilating, and air-conditioning equipment can be hazardous and requires specific knowledge and training. Improperly installed, adjusted or altered equipment by an unqualified person could result in death or serious injury. When working on the equipment, observe all precautions in the literature and on the tags, stickers, and labels that are attached to the equipment.



Introduction

Read this manual thoroughly before operating or servicing this unit.

Warnings, Cautions, and Notices

Safety advisories appear throughout this manual as required. Your personal safety and the proper operation of this machine depend upon the strict observance of these precautions.

The three types of advisories are defined as follows:



Indicates a potentially hazardous situation which, if not avoided, could result in death or serious injury.



Indicates a potentially hazardous situation which, if not avoided, could result in minor or moderate injury. It could also be used to alert against unsafe practices.



Indicates a situation that could result in equipment or property-damage only accidents.

Important Environmental Concerns

Scientific research has shown that certain man-made chemicals can affect the earth's naturally occurring stratospheric ozone layer when released to the atmosphere. In particular, several of the identified chemicals that may affect the ozone layer are refrigerants that contain Chlorine, Fluorine and Carbon (CFCs) and those containing Hydrogen, Chlorine, Fluorine and Carbon (HCFCs). Not all refrigerants containing these compounds have the same potential impact to the environment. Trane advocates the responsible handling of all refrigerants.

Important Responsible Refrigerant Practices

Trane believes that responsible refrigerant practices are important to the environment, our customers, and the air conditioning industry. All technicians who handle refrigerants must be certified according to local rules. For the USA, the Federal Clean Air Act (Section 608) sets forth the requirements for handling, reclaiming, recovering and recycling of certain refrigerants and the equipment that is used in these service procedures. In addition, some states or municipalities may have additional requirements that must also be adhered to for responsible management of refrigerants. Know the applicable laws and follow them.

⚠ WARNING

Proper Field Wiring and Grounding Required!

Failure to follow code could result in death or serious injury.

All field wiring **MUST** be performed by qualified personnel. Improperly installed and grounded field wiring poses **FIRE** and **ELECTROCUTION** hazards. To avoid these hazards, you **MUST** follow requirements for field wiring installation and grounding as described in **NEC** and your local/state/national electrical codes.

⚠ WARNING

Personal Protective Equipment (PPE) Required!

Failure to wear proper PPE for the job being undertaken could result in death or serious injury.

Technicians, in order to protect themselves from potential electrical, mechanical, and chemical hazards, **MUST** follow precautions in this manual and on the tags, stickers, and labels, as well as the instructions below:

- **Before installing/servicing this unit, technicians MUST put on all PPE required for the work being undertaken (Examples; cut resistant gloves/sleeves, butyl gloves, safety glasses, hard hat/bump cap, fall protection, electrical PPE and arc flash clothing). ALWAYS refer to appropriate Safety Data Sheets (SDS) and OSHA guidelines for proper PPE.**
- **When working with or around hazardous chemicals, ALWAYS refer to the appropriate SDS and OSHA/GHS (Global Harmonized System of Classification and Labelling of Chemicals) guidelines for information on allowable personal exposure levels, proper respiratory protection and handling instructions.**
- **If there is a risk of energized electrical contact, arc, or flash, technicians MUST put on all PPE in accordance with OSHA, NFPA 70E, or other country-specific requirements for arc flash protection, PRIOR to servicing the unit. NEVER PERFORM ANY SWITCHING, DISCONNECTING, OR VOLTAGE TESTING WITHOUT PROPER ELECTRICAL PPE AND ARC FLASH CLOTHING. ENSURE ELECTRICAL METERS AND EQUIPMENT ARE PROPERLY RATED FOR INTENDED VOLTAGE.**

⚠ WARNING**Follow EHS Policies!**

Failure to follow instructions below could result in death or serious injury.

- All Trane personnel must follow the company's Environmental, Health and Safety (EHS) policies when performing work such as hot work, electrical, fall protection, lockout/tagout, refrigerant handling, etc. Where local regulations are more stringent than these policies, those regulations supersede these policies.
- Non-Trane personnel should always follow local regulations.

⚠ WARNING**R-454B Flammable A2L Refrigerant!**

Failure to use proper equipment or components as described below could result in equipment failure, and possibly fire, which could result in death, serious injury, or equipment damage.

The equipment described in this manual uses R-454B refrigerant which is flammable (A2L). Use **ONLY** R-454B rated service equipment and components. For specific handling concerns with R-454B, contact your local representative.

⚠ WARNING**Cancer and Reproductive Harm!**

This product can expose you to chemicals including lead and bisphenol A (BPA), which are known to the State of California to cause cancer and birth defects or other reproductive harm. For more information go to www.P65Warnings.ca.gov.

⚠ WARNING**Refrigerant under High Pressure!**

Failure to follow instructions below could result in an explosion which could result in death or serious injury or equipment damage.

System contains refrigerant under high pressure. Recover refrigerant to relieve pressure before opening the system. See unit nameplate for refrigerant type. Do not use non-approved refrigerants, refrigerant substitutes, or refrigerant additives.

⚠ WARNING**Explosion Hazard!**

Failure to follow instructions below could result in an explosion which could result in death or serious injury, and equipment damage.

NEVER bypass system safeties in order to pump down the unit component's refrigerant into the microchannel heat exchanger (MCHE) coil. Do **NOT** depress the compressor contactor since it effectively bypasses the high-pressure control.

Copyright

This document and the information in it are the property of Trane, and may not be used or reproduced in whole or in part without written permission. Trane reserves the right to revise this publication at any time, and to make changes to its content without obligation to notify any person of such revision or change.

Trademarks

All trademarks referenced in this document are the trademarks of their respective owners.

Revision History

- Added Digit 27 — Refrigerant Type to Model Number Description chapter.
- Added R-410A values to the General Data table.
- Updated R-410A values in CAUK air-cooled condenser weights table in Unit weights section in the Dimensions and Weights chapter.
- Added CAUK spring isolator selection table for R-410A in Unit Isolation section in the Installation Mechanical chapter.
- Added Expansion valve selection tables for R-410A in Thermostatic Expansion Valve (TXV) section in the Installation Mechanical chapter.
- Added Recommended refrigerant capacities table and Minimum starting ambient temperatures table in Charging the System section in the Start-Up chapter.



Table of Contents

Model Number Description	5	Final Refrigerant Pipe Connections.....	37
General Information	6	Brazing Procedures	37
Unit Inspection	6	Leak Testing Procedure	38
Exterior Inspection	6	Installation Electrical	39
Inspection for Concealed Damage.....	6	Electrical	39
Repair.....	6	Wiring Requirements	40
Nameplates.....	6	Main Unit Power Wiring	40
Unit Nameplate	6	Controls Wiring	41
Unit Description	6	Operating Principles	42
General Data	7	Component Locations	42
A2L Information	8	Condenser Fans	42
A2L Work Procedures	8	Unit Operation	42
Servicing	8	Condenser Fans	43
Leak Detection	9	Low Ambient Control	43
Refrigerant Removal and Evacuation.....	9	Pre-Start	44
Refrigerant Charging	10	System Evacuation Procedures.....	44
Decommissioning	10	Standing Vacuum Test	45
Dimensions and Weights.....	11	Voltage Imbalance	45
Unit Clearances	11	Electrical Phasing	46
Unit Dimensions.....	13	Start-Up.....	47
Unit Weights	27	Verifying Proper Condenser Fan Rotation.....	47
Installation Mechanical.....	28	Charging the System.....	47
Location Requirements.....	28	Maintenance	51
Isolation	28	Monthly Maintenance	51
Foundation.....	28	Air Handling Equipment.....	51
Leveling the Unit	28	Condensing Unit	51
Rigging and Lifting	28	Coil Cleaning.....	51
Unit Mounting	30	Microchannel Condenser Coil Repair and Replacement	52
Unit Isolation	31	Fall Restraint — Condenser Roof	52
Neoprene Isolators (20 to 60 Ton units).....	31	Warranty and Liability Clause.....	54
Spring Isolators (20 to 120 Ton units).....	32	Commercial Equipment Rated 20 Tons and Larger and Related Accessories	54
Installation.....	33	Products Covered.....	54
General Unit Requirements.....	33	Wiring Diagrams.....	55
Refrigerant Piping Requirements.....	33		
Refrigerant Piping Components	33		
Refrigerant Piping.....	36		



Model Number Description

Digit 1 — Unit Type

C = Condenser

Digit 2 — Condenser

A = Air-Cooled

Digit 3 — System Type

U = Upflow

Digit 4 — Development Sequence

K = Fourth

Digit 5, 6, 7 — Nominal Capacity

C20 = 20 Tons
C25 = 25 Tons
C30 = 30 Tons
C40 = 40 Tons
C50 = 50 Tons
C60 = 60 Tons
C80 = 80 Tons
D10 = 100 Tons
D12 = 120 Tons

Digit 8 — Voltage and Start Characteristics

E = 200/60/3
F = 230/60/3
4 = 460/60/3
5 = 575/60/3
* = 380/50/3
* = 415/50/3

Digit 9 — Condenser Circuit

1 = Single
2 = Dual

Digit 10 — Design Sequence

Factory Assigned

Digit 11 — Ambient Control

0 = Standard
1 = 0°F (Low Ambient Option)

Digit 12 — Agency Approval

0 = None
3 = cULus (60 Hz only)

Digit 13 — Not used

0 = Not used

Digit 14 — Not used

0 = Not used

Digit 15 — Not used

0 = Not used

Digit 16 — Not used

0 = Not used

Digit 17 — Not used

0 = Not used

Digit 18 — Corrosion Protected Condenser Coil

0 = None
J = Corrosion Protected Condenser Coil

Digit 19 — Not used

0 = Not used

Digit 20 — Isolators

0 = None
1 = Spring Isolator
2 = Neoprene Isolators

Digit 21 — Unpowered Convenience Outlet

0 = None
2 = Unpowered 20A Convenience Outlet

Digit 22 — Not used

0 = Not used

Digit 23 — Not used

0 = Not used

Digit 24 — Not used

0 = Not used

Digit 25 — Not used

0 = Not used

Digit 26 — Not used

0 = Not used

Digit 27 — Refrigerant Type

A = R-410A
B = R-454B

Notes:

1. The service digit for each model number contains 26 digits. All 26 digits must be referenced.
2. * = Design special.



General Information

Unit Inspection

To protect against loss due to damage incurred in transit, perform inspection immediately upon receipt of the unit.

Exterior Inspection

If the job site inspection reveals damage or material shortages, file a claim with the carrier immediately. Specify the type and extent of the damage on the bill of lading before signing. Notify the appropriate sales representative.

Important: Do not proceed with installation of a damaged unit without sales representative's approval.

- Visually inspect the complete exterior for signs of shipping damages to unit or packing material.
- Verify that the nameplate data matches the sales order and bill of lading.
- Verify that the unit is properly equipped and there are no material shortages.
- Verify that the power supply complies with the unit nameplate specifications.

Inspection for Concealed Damage

Visually inspect the components for concealed damage as soon as possible after delivery and before it is stored.

Do NOT walk on the sheet metal base pans. Bridging between the unit's main supports may consist of multiple 2 by 12 boards or sheet metal grating.

⚠ WARNING

No Step Surface!

Failure to follow instruction below could result in death or serious injury.

Do not walk on the sheet metal drain pan. Walking on the drain pan could cause the supporting metal to collapse and result in the operator/technician falling.

If concealed damage is discovered:

- Notify the carrier's terminal of the damage immediately by phone and by mail.
- Concealed damage must be reported within 15 days.
- Request an immediate, joint inspection of the damage with the carrier and consignee.
- Stop unpacking the unit.
- Do not remove damaged material from receiving location.
- Take photos of the damage, if possible.

- The owner must provide reasonable evidence that the damage did not occur after delivery.

Repair

Notify the appropriate sales representative before arranging unit installation or repair.

Important: Do not repair unit until the damage has been inspected by the carrier's representative.

Nameplates

Unit Nameplate

One Mylar unit nameplate is located on the outside upper right corner of the control panel door. It includes the unit model number, serial number, electrical characteristics, weight, refrigerant charge, as well as other pertinent unit data. A small metal nameplate with model number, serial number, and unit weight is located just above the Mylar nameplate, and a third nameplate is located on the inside of the control panel door.

When ordering replacement parts or requesting service, be sure to refer to the specific model number, serial number, and DL number (if applicable) stamped on the unit nameplate.

Unit Description

All air cooled condensing units are designed for outdoor installations with vertical air discharge. These units may be installed on a flat roof or placed on a concrete slab at ground level.

Before shipment, each unit is leak-tested, evacuated, a nitrogen holding charge is added, and the controls are tested for proper operation.

The condenser coils are all-aluminum microchannel design. Corrosion protected condenser coils are a standard option. Louvered condenser grilles for coil protection are standard. Direct-drive, vertical discharge condenser fans are provided with built-in current and overload protection.

If low ambient operation is required, low ambient outdoor fan control kits are available as a field or factory installed option.

The unit control panel contains all required fan cycling controls, compressor interlocks, and a 115 volt control power transformer. Electrical schematics and device location diagrams are located inside the control panel access door.

General Data

Table 1. General data — CAUK condensers

Unit Size (tons)		20	25	30	40	50	60	80	100	120
Condenser Fan Data										
Type/Drive Type		Prop/Direct								
Qty		2	3	3	4	6	6	8	12	12
Diameter	in	26	26	26	26	26	26	26	26	26
Power/motor	hp	1	1	1	1	1	1	1	1	1
Nominal Total Airflow	cfm	14600	20700	20700	26790	36890	40490	56490	73890	76280
Condenser Coil Data										
Type		Microchannel								
Number of Coils		2	2	2	2	2	2	4	4	4
Size	in	42x71	42x71	42x71	59x71	51x96	51x96	59x71	51x96	64x96
Face Area	ft ²	41.4	41.4	41.4	58.2	68	68	116.4	136	170.7
Rows/Fin Per Ft.		1/240	1/240	1/240	1/240	1/240	1/240	1/240	1/240	1/240
Storage Capacity R-410A ^(a)	lbs	18.7	18.7	18.7	23.5	25	25	47.1	50	62.9
Storage Capacity R-454B ^(a)	lbs	11.5	11.5	11.5	22.9	23.9	23.9	45.7	47.8	60.2
Refrigerant Data^(b)										
Type										
Operating Charge R-410A ^(c)	lbs	11.9	11.8	11.8	22.7	23.4	23.8	57.1	59.1	65.3
Operating Charge R-454B ^(c)	lbs	6.8	6.7	8	13.8	14	14.7	38.2	38.2	41.1
Outdoor Air Temperature for Mechanical Cooling										
Standard Ambient Operating Range	°F	40-115	40-115	40-115	40-115	40-115	40-115	40-115	40-115	40-115
Low Ambient Option	°F	0-115	0-115	0-115	0-115	0-115	0-115	0-115	0-115	0-115

^(a) Condenser storage capacity is given at conditions of 95°F outdoor temperature, and 95% full.

^(b) Refer to Refrigerant Piping in the Application Considerations section. Condensing units are shipped with nitrogen holding charge only.

^(c) Operating charge is approximate for condensing unit only, and does not include charge for low side or interconnecting lines. Condensing units are shipped with a nitrogen holding charge only.



A2L Information

A2L Work Procedures

⚠ WARNING

Risk of Fire — Flammable Refrigerant!

Failure to follow instructions below could result in death or serious injury, and equipment damage.

- To be repaired only by trained service personnel.
- Do not puncture refrigerant tubing.
- Dispose of properly in accordance with federal or local regulations.
- The equipment shall be stored in a room without continuously operating ignition sources.

⚠ WARNING

Refrigerant under High Pressure!

Failure to follow instructions below could result in an explosion which could result in death or serious injury or equipment damage.

System contains refrigerant under high pressure. Recover refrigerant to relieve pressure before opening the system. See unit nameplate for refrigerant type. Do not use non-approved refrigerants, refrigerant substitutes, or refrigerant additives.

⚠ WARNING

Hazardous Voltage!

Failure to disconnect power before servicing could result in death or serious injury.

Disconnect all electric power, including remote disconnects before servicing. Follow proper lockout/tagout procedures to ensure the power can not be inadvertently energized. Verify that no power is present with a voltmeter.

The units described in this manual use R-454B refrigerant. Use ONLY R-454B rated service equipment or components with these units. For specific handling concerns with R-454B, contact your local Trane representative.

Installation, repair, removal, or disposal should be performed by trained service personnel.

At all times, Trane's maintenance and service guidelines shall be followed. If in doubt, contact Trane technical support for assistance.

Servicing

Prior to initiating work on equipment, check the area with an appropriate refrigerant detector. Ensure the service personnel are properly trained regarding work in potentially toxic or flammable atmospheres. Ensure that the leak

detection equipment being used is suitable for use with all applicable refrigerants, i.e. non-sparking, adequately sealed, or intrinsically safe. Be aware that the refrigerant does not contain an odor.

If any hot work is to be conducted on the refrigerating equipment or any associated parts, appropriate fire extinguishing equipment shall be available on hand. A dry powder or CO₂ fire extinguisher should be located adjacent to the charging area.

At all times, Trane's maintenance and service guidelines shall be followed. If in doubt, contact Trane technical support for assistance.

All maintenance staff and others working in the local area shall be instructed on the nature of the work being carried out. Work in confined spaces shall be avoided.

Ignition Source Mitigation

Do not use any sources of ignition when working on the refrigeration system.

Keep all ignition sources, including cigarette smoking, away from the site of installation, repair, removal or disposal, during which refrigerant can potentially be released to the surrounding space.

Survey the area around the equipment before initiating work to ensure no flammable hazards or ignition risks are present.

"No Smoking" signs shall be displayed.

Do not use devices that can be a source of ignition to accelerate defrosting of components. Use only defrost and cleaning procedures recommended by Trane. Do not pierce or burn.

Ventilation

Ensure that the area is in the open or that it is adequately ventilated before breaking into the system or conducting any hot work. A degree of ventilation shall continue during the period that the work is carried out. The ventilation should safely disperse any released refrigerant and preferably expel it externally into the atmosphere. If present, check that the ventilation system, including outlets, are operating adequately and are not obstructed.

Refrigerating Equipment

Refrigerant piping or components should not be installed in locations where substances which may corrode them are present.

Check that equipment hazard markings are visible and legible. Replace them if they are not.

For equipment using secondary fluids, like water or glycol, check that refrigerant is not present in the secondary fluid loop before conducting any hot work.

Electrical Devices

Do not apply power to the circuit if a fault exists which compromises safety. If the fault cannot be corrected immediately, but it is necessary to continue operation, an adequate temporary solution shall be used. This shall be reported to the owner of the equipment, so all parties are advised.

Initial safety checks shall include:

- Cabling is not subject to wear, corrosion, excessive pressure, vibration, sharp edges, or any other adverse environmental effects. Account for the effects of aging or continual vibration from sources such as compressors or fans.
- Capacitors are discharged. This shall be done in a safe manner to avoid possibility of sparking.
- No live electrical components and wiring are exposed while charging, recovering, or purging the system.
- Verify continuity of earth bonding.
- Replace electrical components with Trane replacement parts, or those meeting the same ratings and qualified for flame arrest protection, UL LZGH2 category.

Leak Detection

Never use an open flame to detect leaks. A halide torch should not be used. Use only approved leak detection methods per this instruction manual.

The following leak detection methods are deemed acceptable for all refrigerant systems.

Electronic leak detectors may be used to detect refrigerant leaks but, in the case of flammable refrigerants, the sensitivity may not be adequate, or may need re-calibration. (Detection equipment shall be calibrated in a refrigerant-free area.) Verify the detector is not a potential source of ignition and is suitable for the refrigerant used. Leak detection equipment shall be set at a percentage of the LFL gas (25% maximum) is confirmed.

Leak detection fluids are also suitable for use with most refrigerants but the use of detergents containing chlorine shall be avoided as the chlorine may react with the refrigerant and corrode the copper pipe-work.

Examples of leak detection fluids are:

- Bubble method
- Fluorescent method agents

If a leak is suspected, all naked flames shall be removed/extinguished.

If a refrigerant leak is found which requires brazing, all refrigerant shall be recovered from the system, or isolated (by means of shut-off valves) in a part of the system remote from the leak.

Refrigerant Removal and Evacuation

Ensure that the correct number of cylinders for holding the total system charge is available. All cylinders to be used are designated for the recovered refrigerant and labeled for

that refrigerant (special cylinders for the recovery of refrigerant, for example). Cylinders shall be complete with pressure-relief valve and associated shut-off valves in good working order. Empty recovery cylinders are evacuated and, if possible, cooled before recovery occurs.

When breaking into the refrigerant circuit to make repairs – or for any other purpose – conventional procedures shall be used. However, for flammable refrigerants it is important that best practice be followed, since flammability is a consideration.

The following procedure shall be adhered to:

1. Safely remove refrigerant following local and national regulations.
2. Evacuate.
3. Purge the circuit with inert gas.
4. Evacuate (optional for A2L).
5. Continuously flush or purge with inert gas when using flame to open circuit.
6. Open the circuit.

Prior to refrigerant removal, open all appropriate valves, including solenoid and electronic expansion valves (EXVs). Use control settings, where available. When not available, manually open all electronically controlled valves using acceptable service procedures.

The recovery equipment shall be in good working order with instructions available. Equipment shall be suitable for the recovery of the flammable refrigerant. For specific handling concerns, contact the manufacturer. Ensure all hose connections are checked for tightness to avoid refrigerant leaks.

In addition, a set of calibrated weighing scales shall be available and in good working order.

The refrigerant shall be recovered into the correct recovery cylinders if venting is not allowed by local and national codes. Do not mix refrigerants in recovery unit and especially not in cylinders.

Refrigerant recovery unit should be purged with an inert gas after each use or before using with a different refrigerant Class – for example, A2L to A1.

If compressors or compressor oils are to be removed, ensure that they have been evacuated to an acceptable level to make certain that flammable refrigerant does not remain within the lubricant. The compressor body shall not be heated by an open flame or other ignition sources to accelerate this process. When oil is drained from a system, it shall be carried out safely.

The system shall be purged with oxygen-free nitrogen to render the appliance safe for flammable refrigerants. This process might need to be repeated several times. Compressed air or oxygen shall not be used for purging refrigerant systems.

The system shall be vented down to atmospheric pressure to enable work to take place.

The outlet for the vacuum pump shall not be close to any potential ignition sources, and ventilation shall be available.

Refrigerant Charging

In addition to conventional charging procedures, the following requirements shall be followed.

- Ensure that contamination of different refrigerants does not occur when using charging equipment.
- Hoses or lines shall be as short as possible to minimize the amount of refrigerant contained in them.
- Cylinders shall be kept in an appropriate position according to the instructions.
- Ensure that the refrigerating system is earthed prior to charging the system with refrigerant.
- Label the system when charging is complete (if not already).
- Extreme care shall be taken not to overfill the refrigerating system.

Prior to recharging the system, it shall be pressure-tested with the appropriate purging gas. The system shall be leak-tested on completion of charging but prior to commissioning. A follow up leak test shall be carried out prior to leaving the site.

Prior to refrigerant charging, open all appropriate valves, including solenoid and electronic expansion valves (EXVs). Use control settings, where available. When not available, manually open all electronically controlled valves using acceptable service procedures.

Verify the equipment refrigerant charge is in accordance with the room area limitation as described in Minimum Room Area Limits section.

Decommissioning

Before carrying out the decommissioning procedure, it is essential that the trained service personnel is completely familiar with the equipment and all its details. It is recommended good practice that all refrigerants are recovered safely. Prior to the task being carried out, an oil and refrigerant sample shall be taken in case analysis is required prior to re-use of recovered refrigerant. It is essential that electrical power is available before the task is commenced.

1. Become familiar with the equipment and its operation.
2. Isolate system electrically.
3. Before attempting the procedure, ensure that:
 - a. Mechanical handling equipment is available, if required, for handling refrigerant cylinders.
 - b. All personal protective equipment is available and being used correctly.
 - c. The recovery process is supervised at all times by a competent person.
 - d. Recovery equipment and cylinders conform to the appropriate standards.

4. Pump down refrigerant system, if possible.
5. If a vacuum is not possible, make a manifold so that refrigerant can be removed from various parts of the system.
6. Make sure that cylinder is situated on the scales before recovery takes place.
7. Start the recovery machine and operate in accordance with instructions.
8. Do not overfill cylinders (no more than 80% volume liquid charge).
9. Do not exceed the maximum working pressure of the cylinder, even temporarily.
10. When the cylinders have been filled correctly and the process completed, make sure that the cylinders and the equipment are removed from site promptly and all isolation valves on the equipment are closed off.
11. Recovered refrigerant shall not be charged into another refrigerating system unless it has been cleaned and checked.
12. When equipment has been decommissioned, attach a signed and dated label stating it has been decommissioned and emptied of refrigerant.
13. Ensure that there are labels on the equipment stating it contains flammable refrigerant.

Dimensions and Weights

Unit Clearances

The figure below illustrates the minimum operating and service clearances for either a single, multiple, or pit application. These clearances are the minimum distances necessary to assure adequate serviceability, cataloged unit capacity, and peak operating efficiency.

Important: *Providing less than the recommended clearances could result in condenser coil starvation or recirculation of hot condenser air.*

Locate the unit as close to the applicable system support equipment as possible to minimize refrigerant piping lengths.

Allow adequate clearance for water and refrigerant piping connections, space to perform service procedures, i.e. read gauges, thermometers, and operate water system valves.

Figure 1. Unit clearances

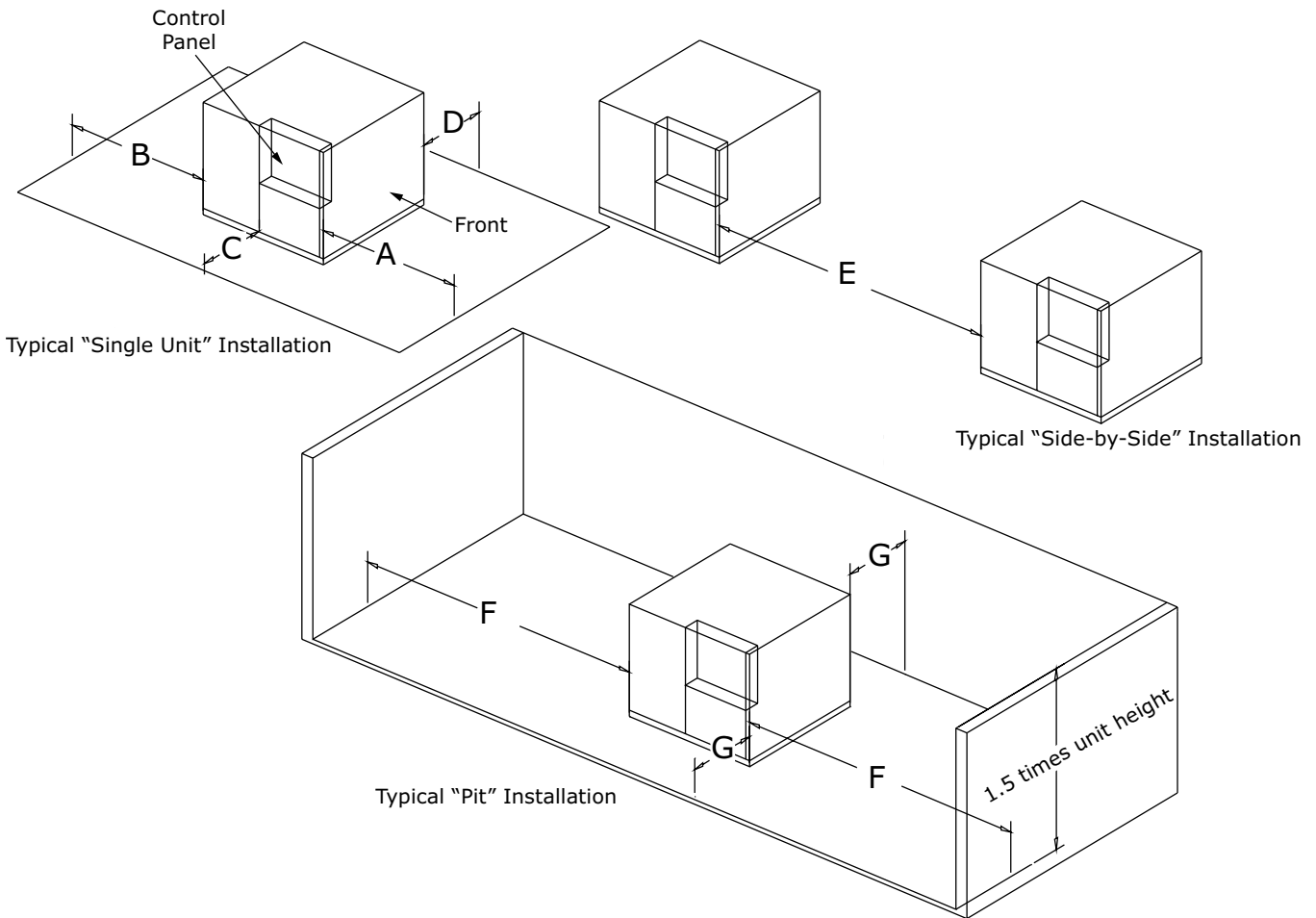



Dimensions and Weights

Table 2. Unit clearances

Dimension	Location	Clearance (in)	
		20 to 60 tons	80 to 120 tons
A	Front	72	96
B	Back	72	96
C	Left (control panel side)	48	48
D	Right	42	48
E	Distance between units (side-by-side)	192	192
F	Pit installation - front and back	192	192
G	Pit installation - sides	48	48

Unit Dimensions

Figure 2. Air-cooled condenser — 20 ton

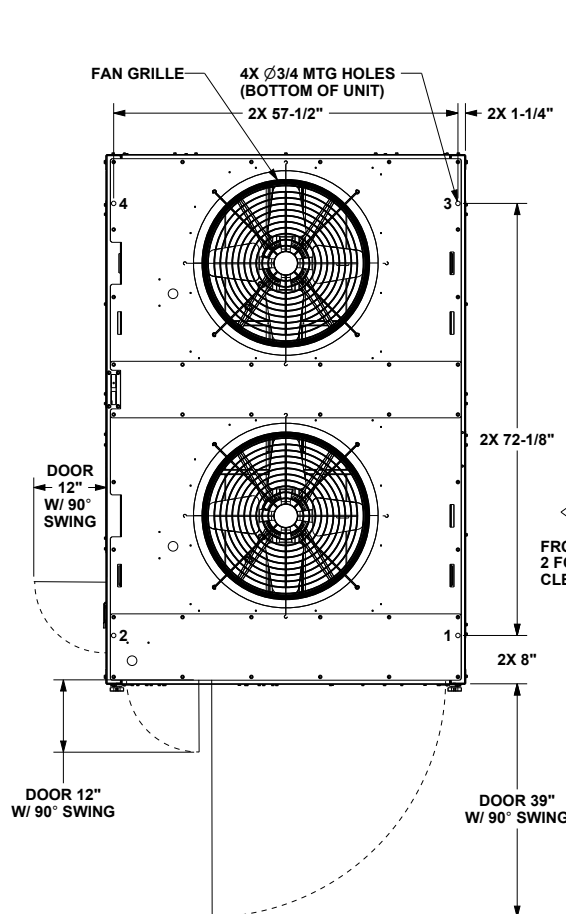

NOTES:

1. SEE CONNECTION DRAWING FOR CONNECTION LOCATION AND SIZES.
2. FRONT OF UNIT CLEARANCE 72" . BACK OF UNIT CLEARANCE 72" . LEFT AND RIGHT SIDE OF UNIT CLEARANCE 48".
3. VOLTAGE ACCESS HOLES IN OUTER PANEL MUST BE COVERED AFTER UNIT INSTALLATION.

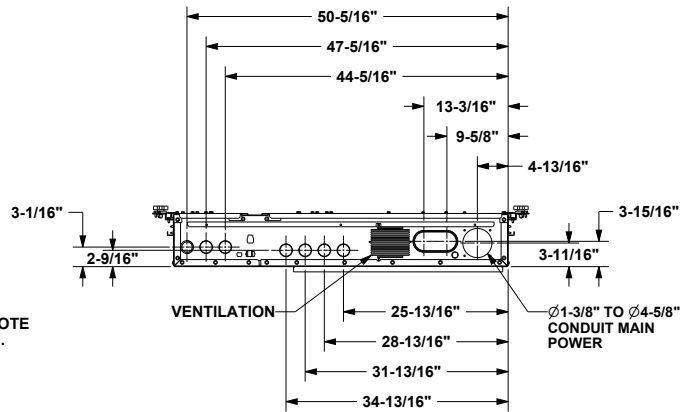

DETAIL A

CONTROL BOX BOTTOM

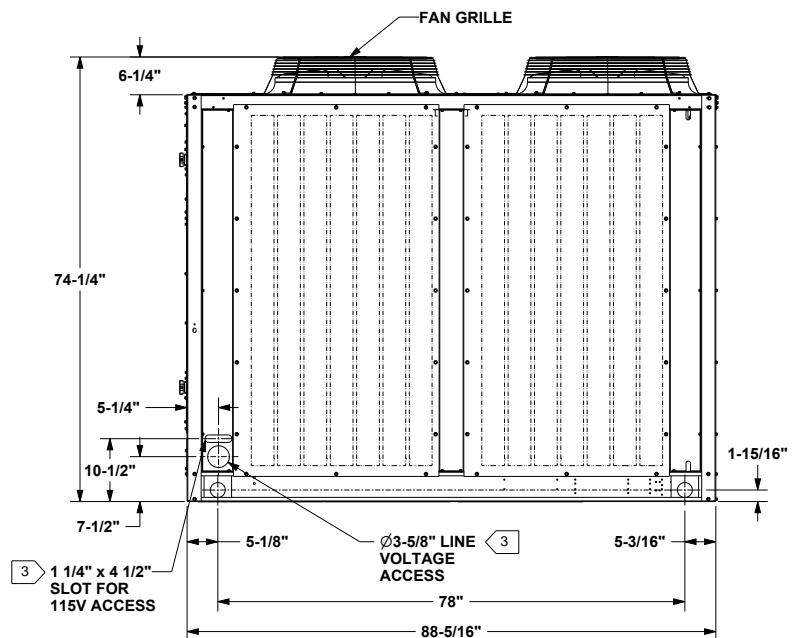
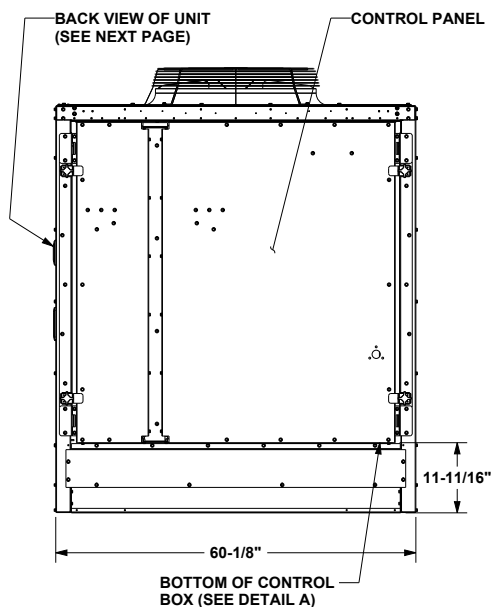



Dimensions and Weights

Figure 3. Air-cooled condenser connections — 20 ton

CONTROL PANEL SIDE

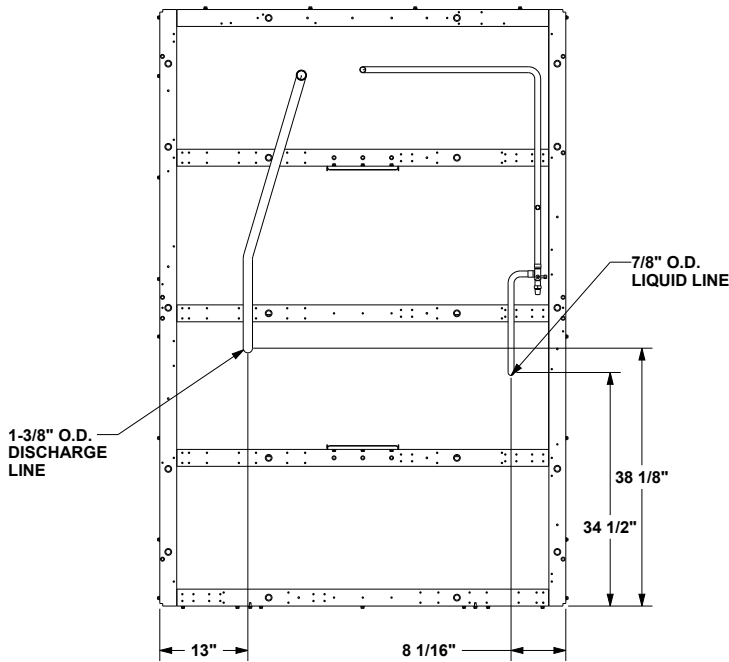

PLAN VIEW OF UNIT
CONNECTION DRAWING

NOTES:

1. VERIFY WEIGHT, CONNECTION, AND ALL DIMENSIONS WITH INSTALLER DOCUMENTS BEFORE INSTALLATION.
2. OPTIONS ONLY COME ON SELECTED UNITS.

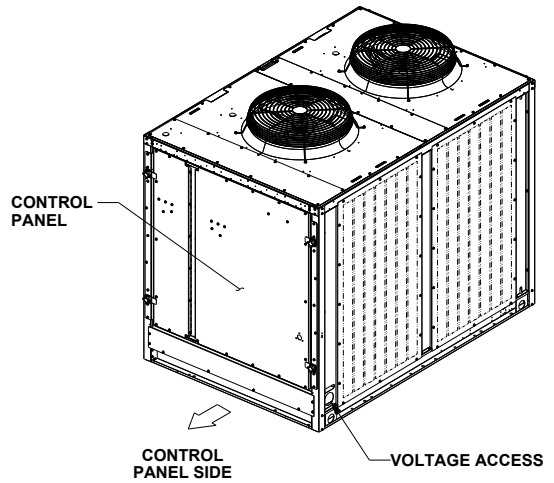

ORIENTATION VIEW OF UNIT
ISOMETRIC DRAWING

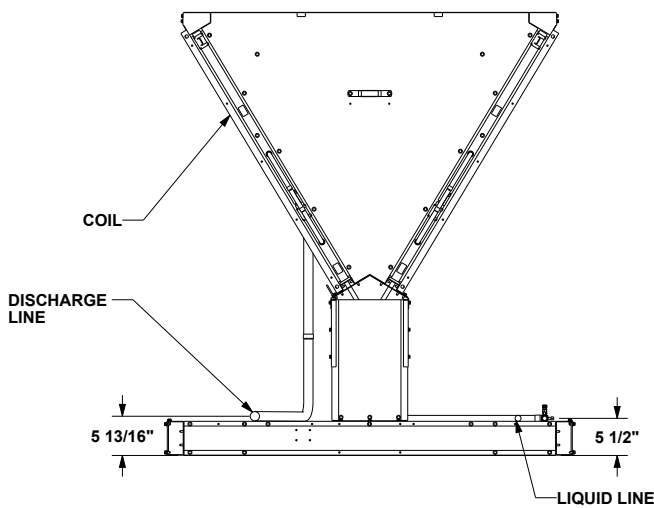

VIEW OPPOSITE OF CONTROL PANEL
CONNECTION DRAWING

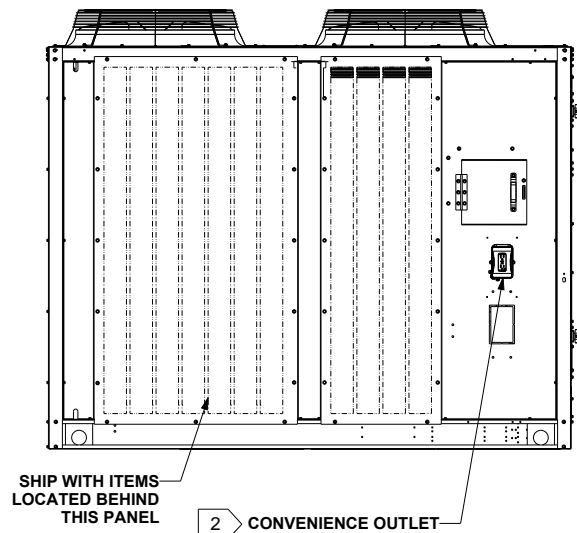

BACK VIEW OF UNIT

20 TON UNIT
DIMENSION CONNECTION DRAWING

Figure 4. Air-cooled condenser — 25 and 30 tons

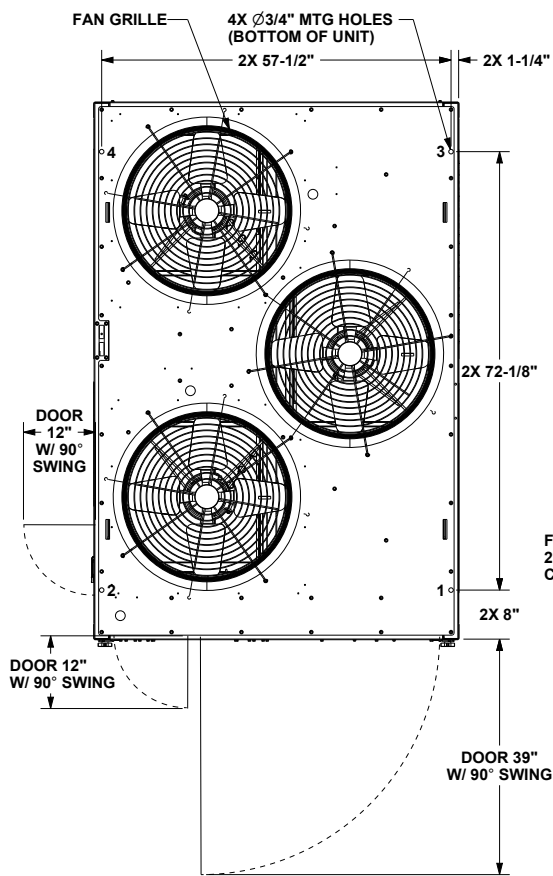

NOTES:

1. SEE CONNECTION DRAWING FOR CONNECTION LOCATION AND SIZES.
2. FRONT OF 25 AND 30 UNIT CLEARANCE 72". BACK OF UNIT CLEARANCE 72". LEFT AND RIGHT SIDE OF 25 AND 30 UNIT CLEARANCE 48"
3. VOLTAGE ACCESS HOLES IN OUTER PANEL MUST BE COVERED AFTER UNIT INSTALLATION

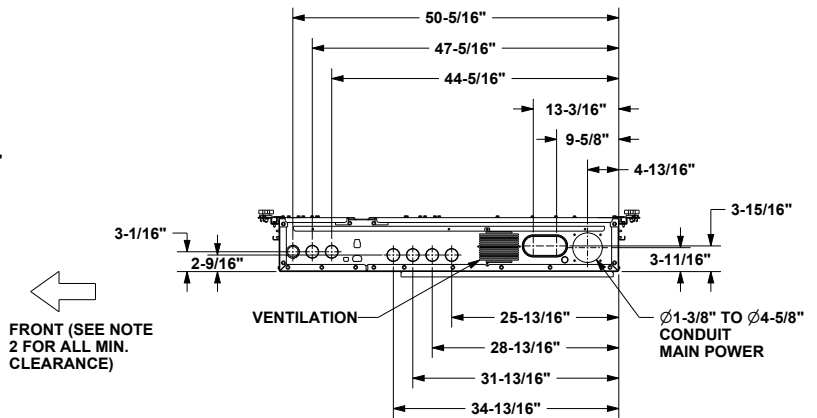

DETAIL A

CONTROL BOX BOTTOM

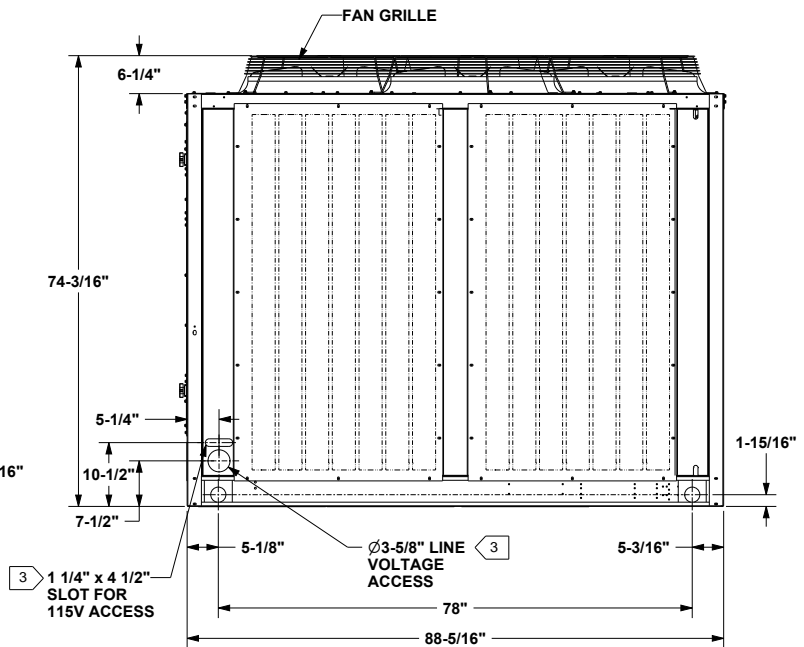
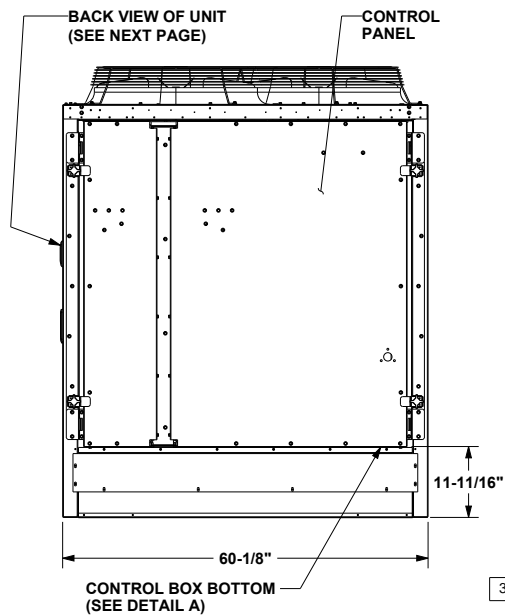

Dimensions and Weights

Figure 5. Air-cooled condenser connections — 25 and 30 tons

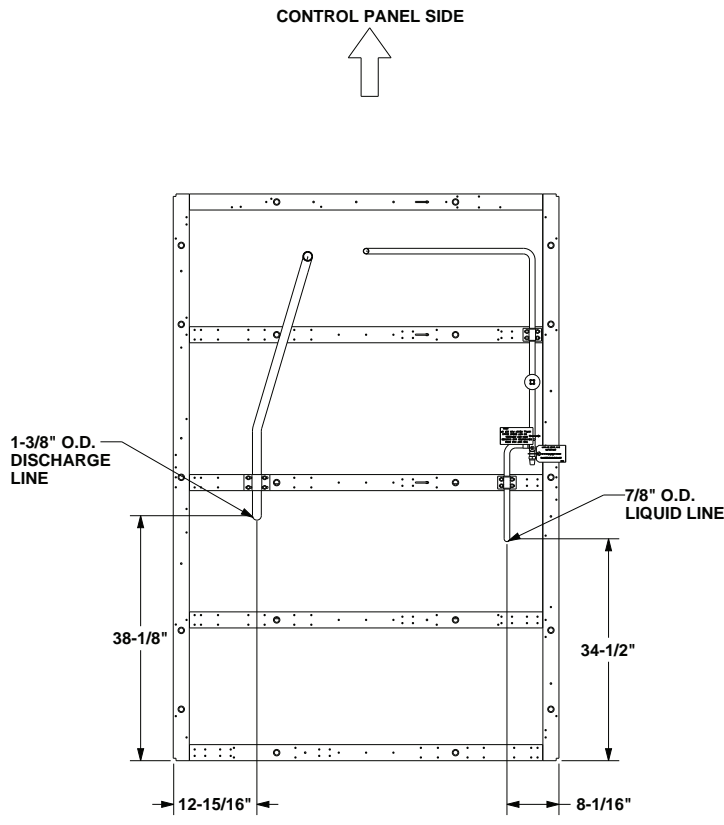

PLAN VIEW OF UNIT
CONNECTION DRAWING

NOTES:

1. VERIFY WEIGHT, CONNECTION, AND ALL DIMENSIONS WITH INSTALLER DOCUMENTS BEFORE INSTALLATION.
2. OPTIONS ONLY COME ON SELECTED UNITS.

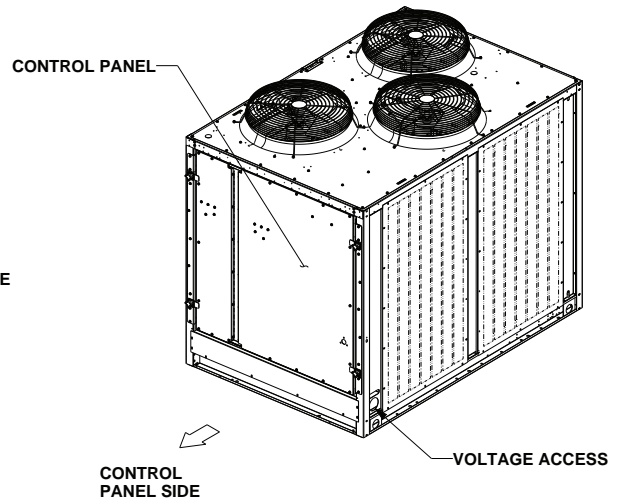

ORIENTATION VIEW OF UNIT
ISOMETRIC DRAWING

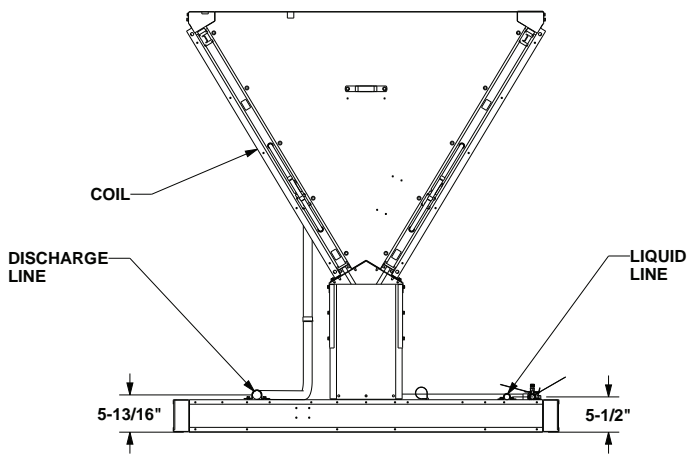

VIEW OPPOSITE OF CONTROL PANEL
CONNECTION DRAWING

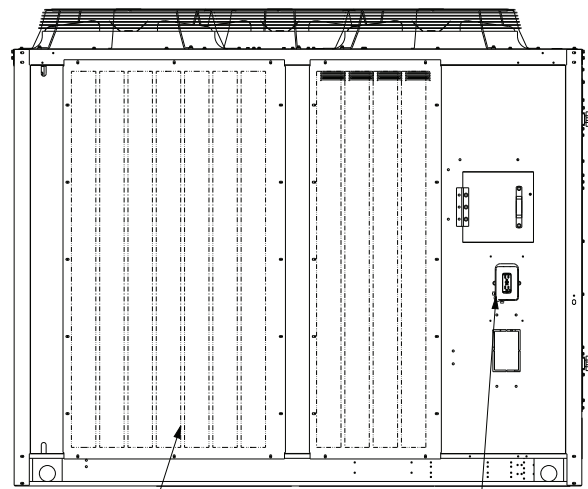

BACK VIEW OF UNIT

Figure 6. Air-cooled condenser — 40 ton

NOTES:

1. SEE CONNECTION DRAWING FOR CONNECTION LOCATION AND SIZES.
2. OPTIONS ONLY COME ON SELECTED UNITS.
3. FRONT AND BACK OF UNIT CLEARANCE 72" . LEFT AND RIGHT SIDE OF UNIT CLEARANCE 48"
4. VOLTAGE ACCESS HOLES IN OUTER PANEL MUST BE COVERED AFTER UNIT INSTALLATION

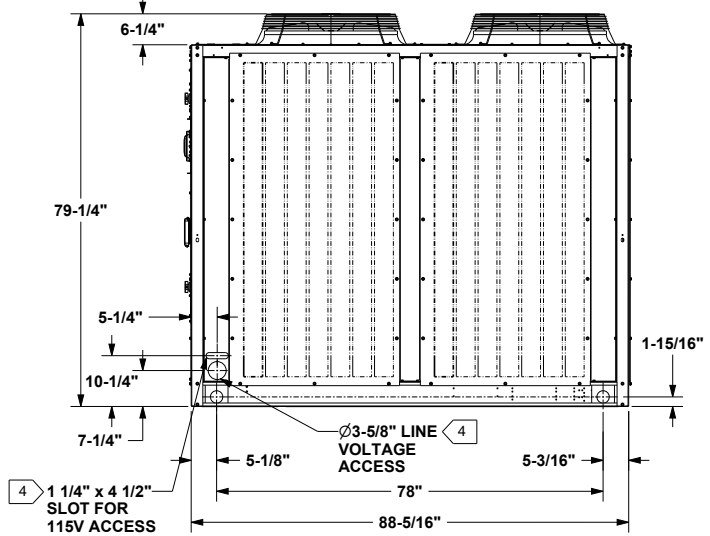
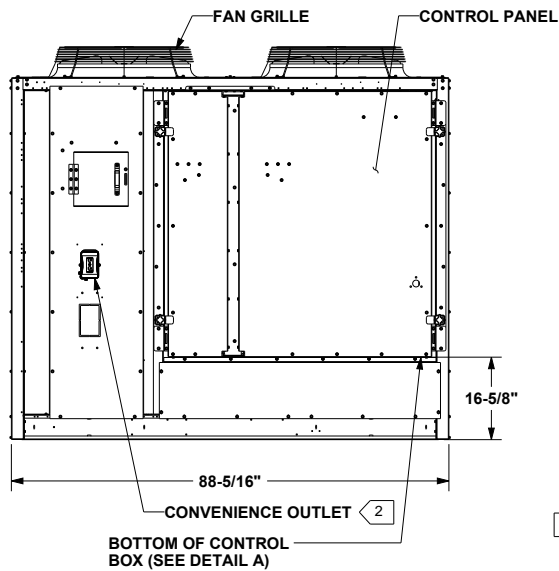
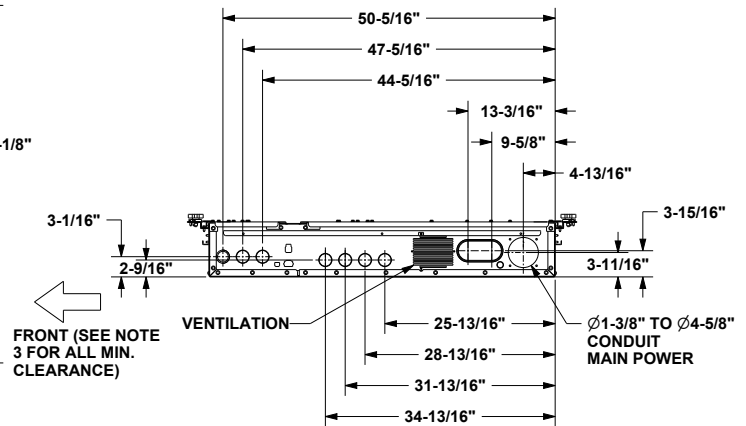
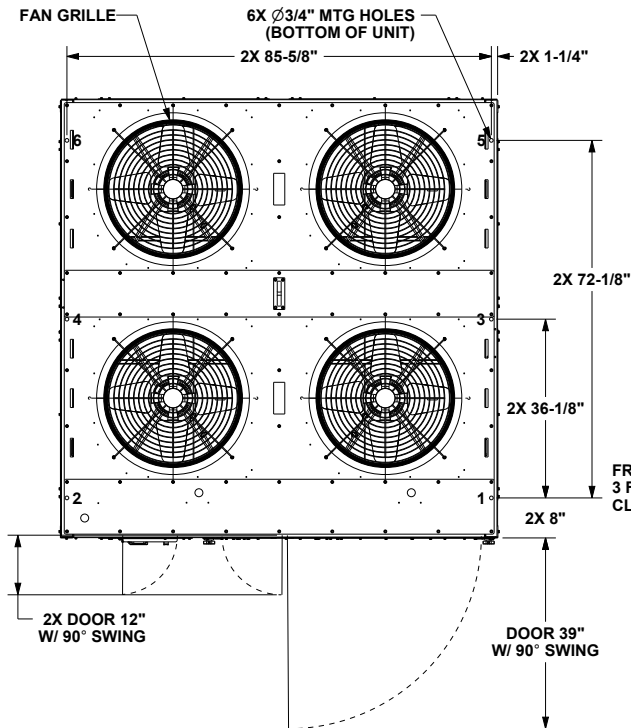

Dimensions and Weights

Figure 7. Air-cooled condenser connections — 40 ton

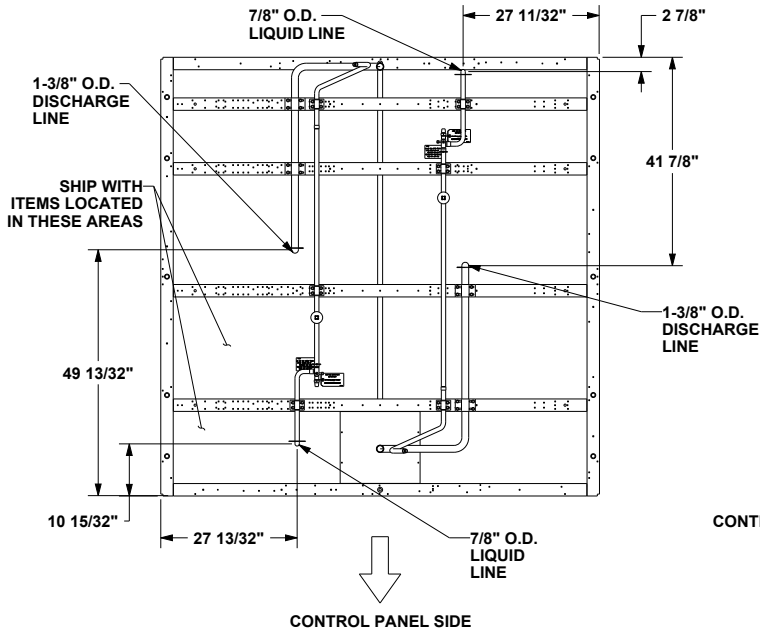

PLAN VIEW OF UNIT
CONNECTION DRAWING

NOTES:

1. VERIFY WEIGHT, CONNECTION, AND ALL DIMENSIONS WITH INSTALLER DOCUMENTS BEFORE INSTALLATION.
2. DUAL CIRCUIT UNIT REQUIRES TWO SEPARATE LINES SETS (TWO SUCTION) LINES AND TWO LIQUID LINES).

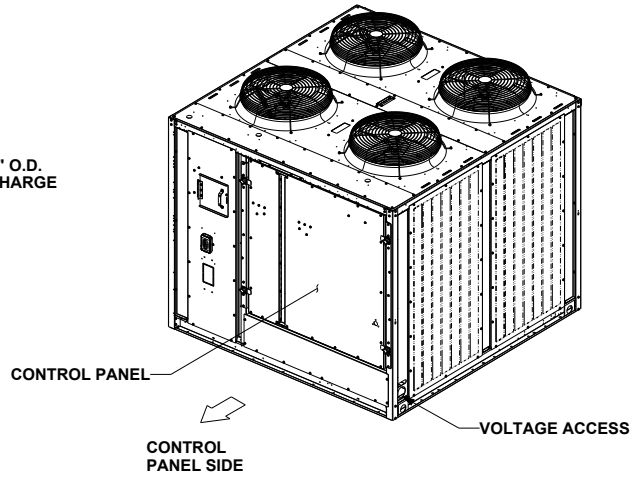

ORIENTATION VIEW OF UNIT
ISOMETRIC DRAWING

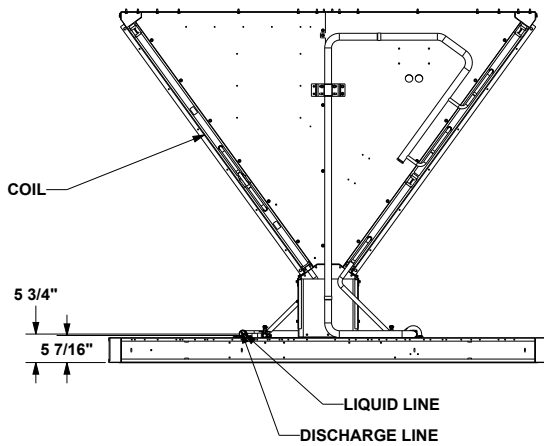

CONTROL PANEL SIDE VIEW OF UNIT
CONNECTION DRAWING

40 TON UNIT
DIMENSION CONNECTION DRAWING

Figure 8. Air-cooled condenser — 50 ton

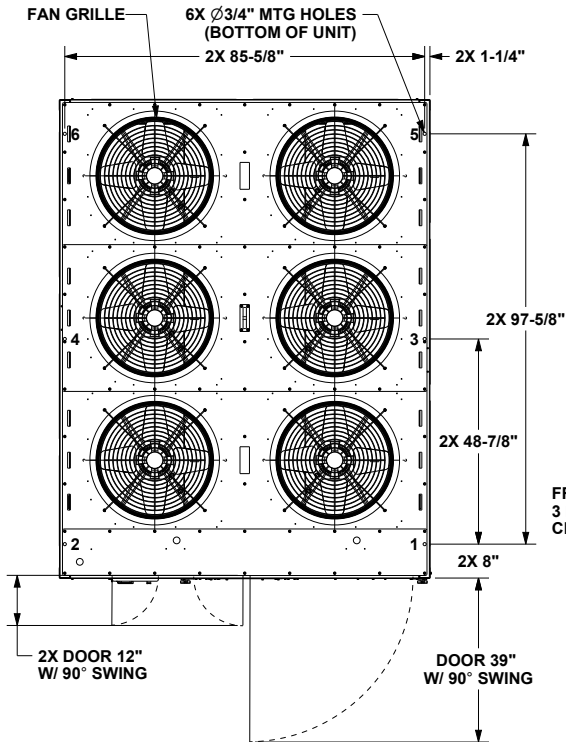

NOTES:

1. SEE CONNECTION DRAWING FOR CONNECTION LOCATION AND SIZES.
2. OPTIONS ONLY COME ON SELECTED UNITS.
3. FRONT AND BACK OF UNIT CLEARANCE 72" . LEFT AND RIGHT SIDE OF UNIT CLEARANCE 48"
4. VOLTAGE ACCESS HOLES IN OUTER PANEL MUST BE COVERED AFTER UNIT INSTALLATION

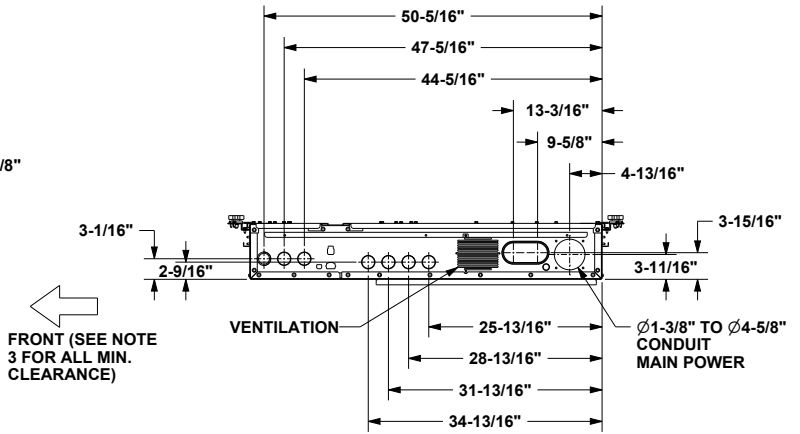

DETAIL A
CONTROL BOX BOTTOM

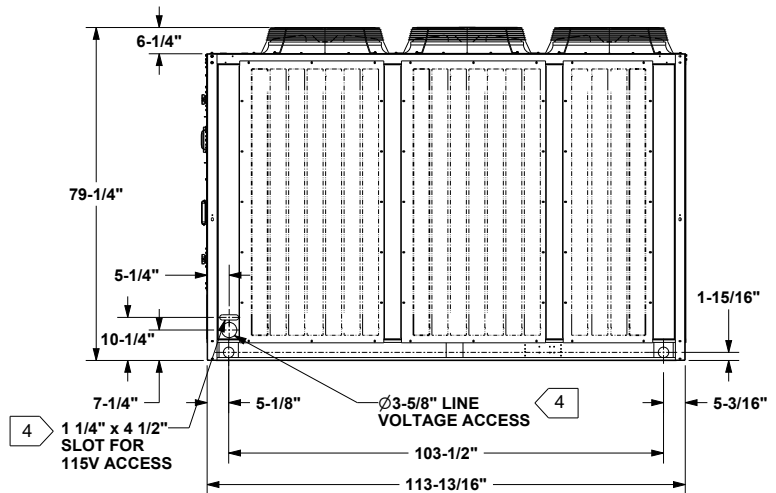
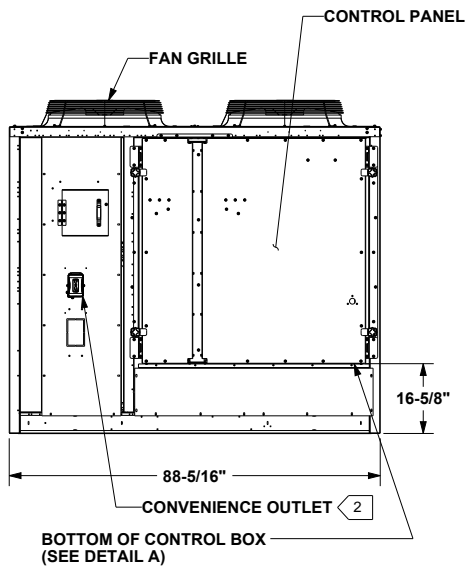
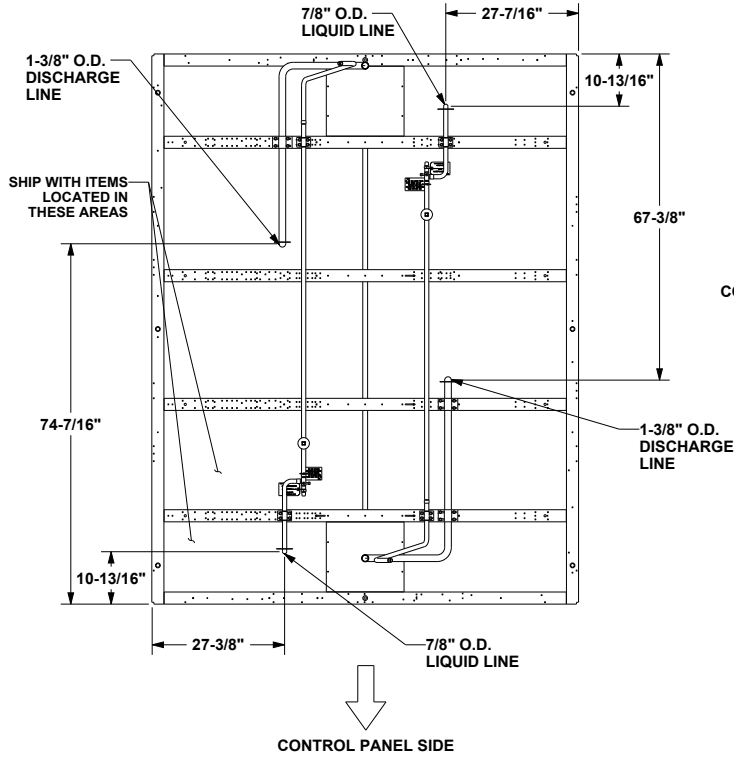
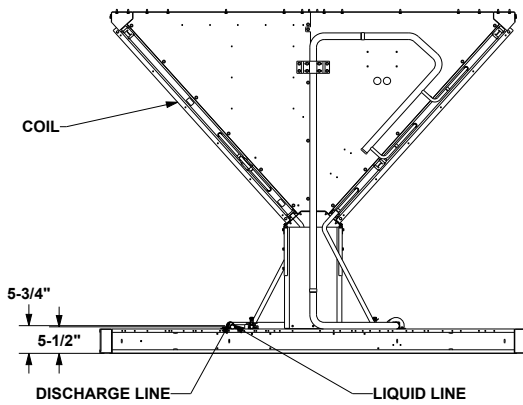

Figure 9. Air-cooled condenser connections — 50 ton



PLAN VIEW OF UNIT
CONNECTION DRAWING



CONTROL PANEL SIDE VIEW OF UNIT
CONNECTION DRAWING

NOTES:

1. VERIFY WEIGHT, CONNECTION, AND ALL DIMENSIONS WITH INSTALLER DOCUMENTS BEFORE INSTALLATION.
2. DUAL CIRCUIT UNIT REQUIRES TWO SEPARATE LINES SETS (TWO SUCTION) LINES AND TWO LIQUID LINES).

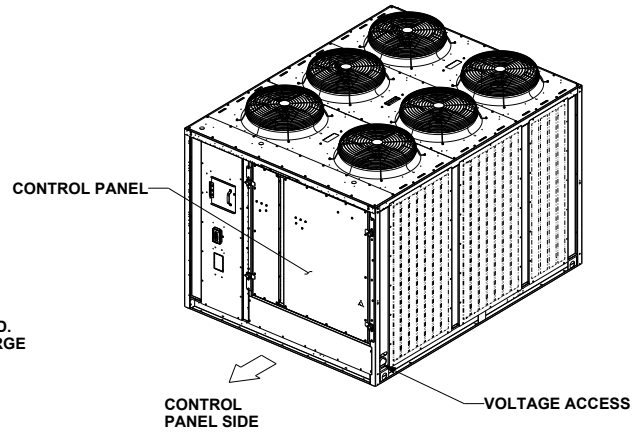

ORIENTATION VIEW OF UNIT
ISOMETRIC DRAWING

50 TON UNIT
DIMENSION CONNECTION DRAWING

Figure 10. Air-cooled condenser — 60 ton

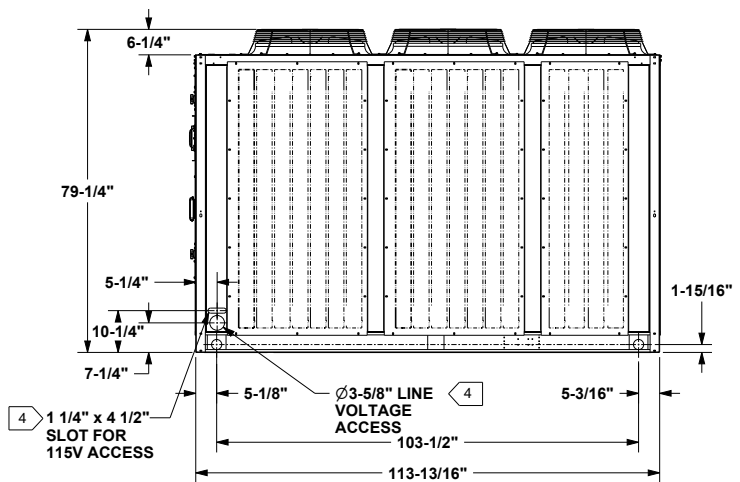
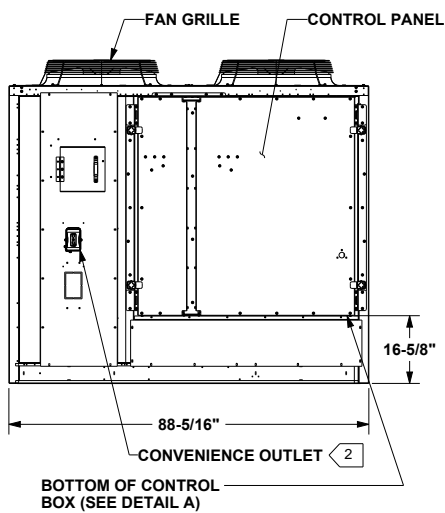
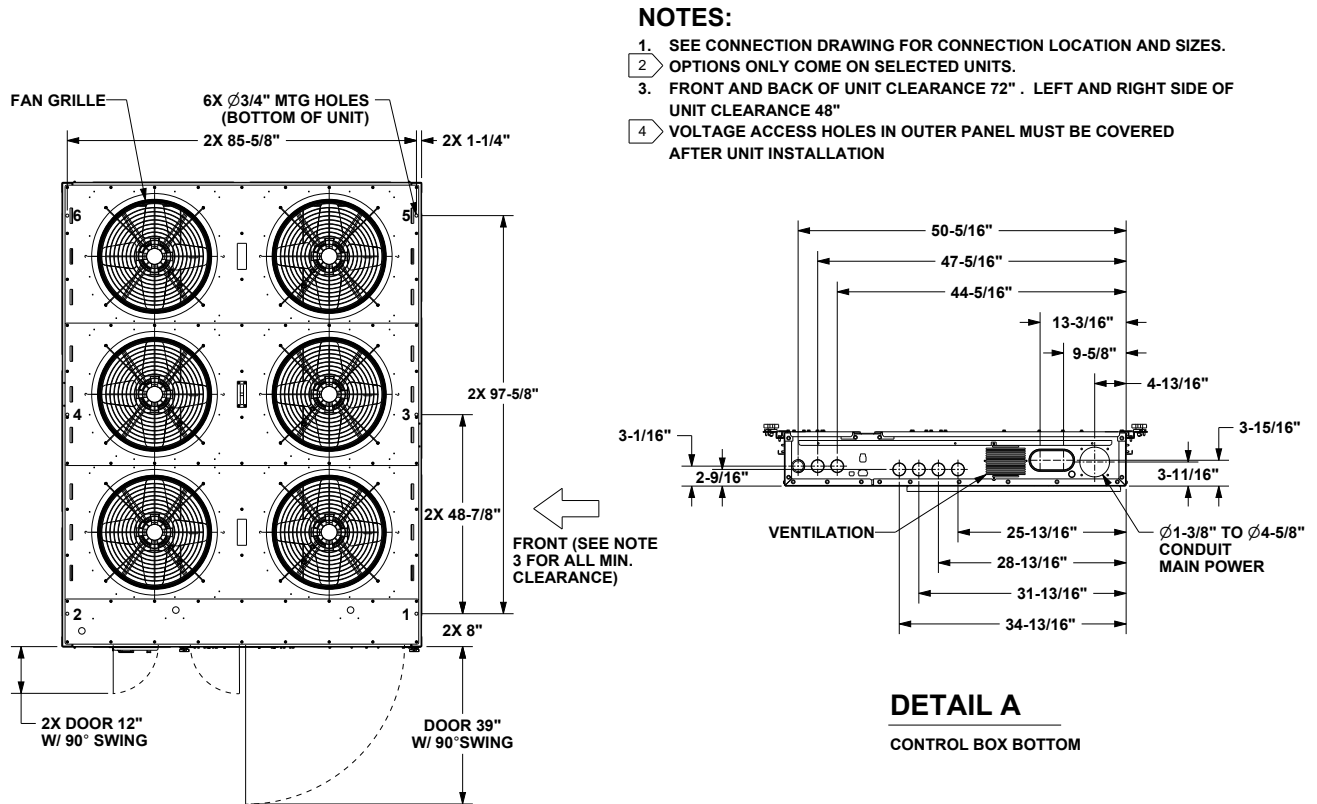

Dimensions and Weights

Figure 11. Air-cooled condenser connections — 60 ton

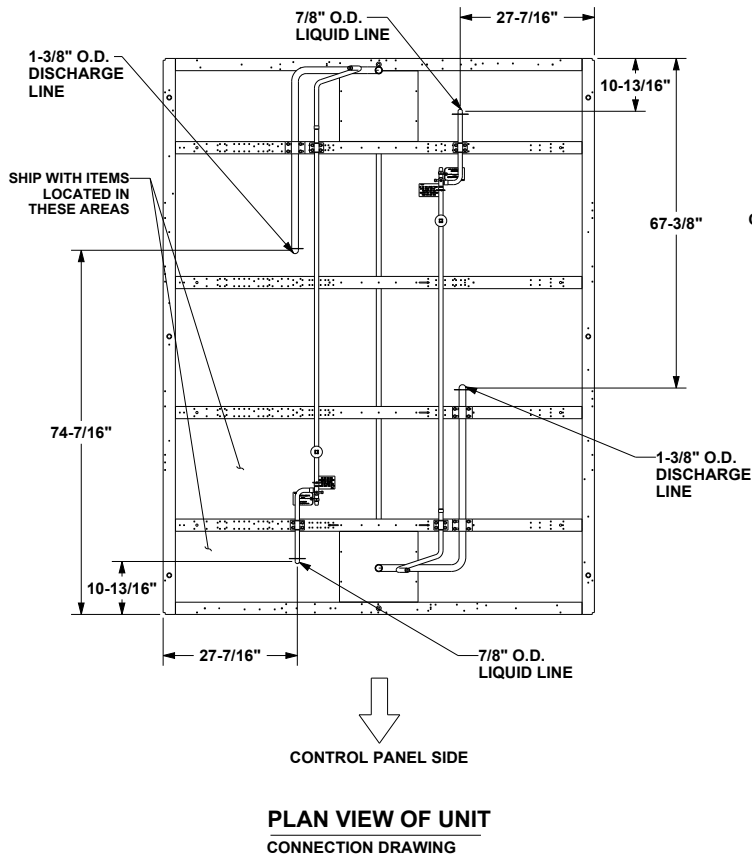

NOTES:

1. VERIFY WEIGHT, CONNECTION, AND ALL DIMENSIONS WITH INSTALLER DOCUMENTS BEFORE INSTALLATION.
2. DUAL CIRCUIT UNIT REQUIRES TWO SEPARATE LINES SETS (TWO SUCTION) LINES AND TWO LIQUID LINES).

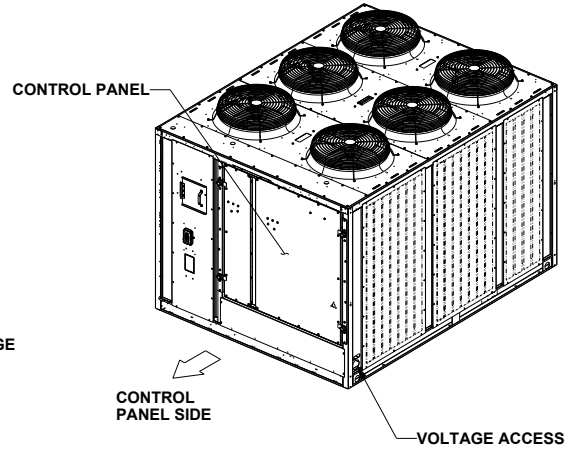

ORIENTATION VIEW OF UNIT
ISOMETRIC DRAWING

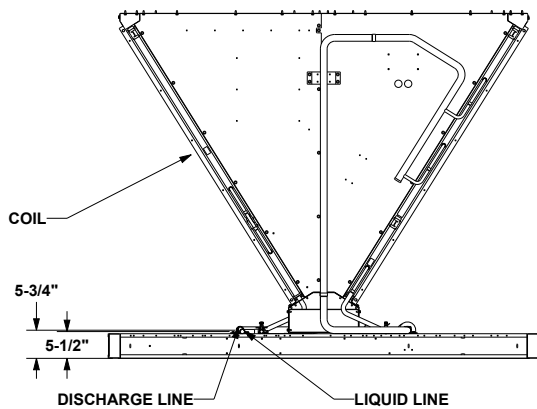

CONTROL PANEL SIDE VIEW OF UNIT
CONNECTION DRAWING

60 TON UNIT
DIMENSION CONNECTION DRAWING

Figure 12. Air-cooled condenser — 80 ton

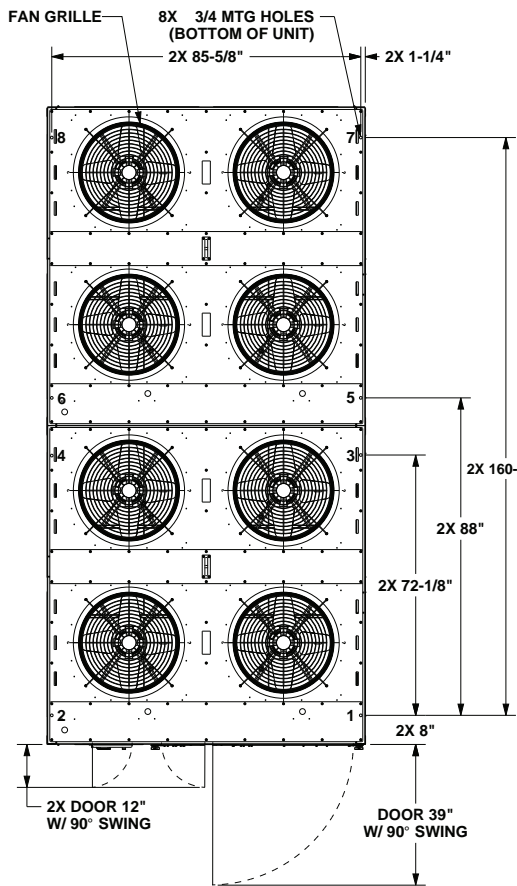

NOTES:

1. SEE CONNECTION DRAWING FOR CONNECTION LOCATION AND SIZES.
2. OPTIONS ONLY COME ON SELECTED UNITS.
3. FRONT AND BACK OF UNIT CLEARANCE 72" . LEFT AND RIGHT SIDE OF UNIT CLEARANCE 48"
4. VOLTAGE ACCESS HOLES IN OUTER PANEL MUST BE COVERED AFTER UNIT INSTALLATION

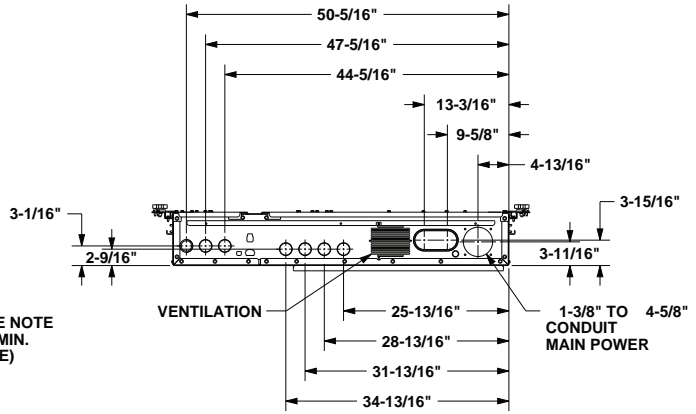

DETAIL A

CONTROL BOX BOTTOM

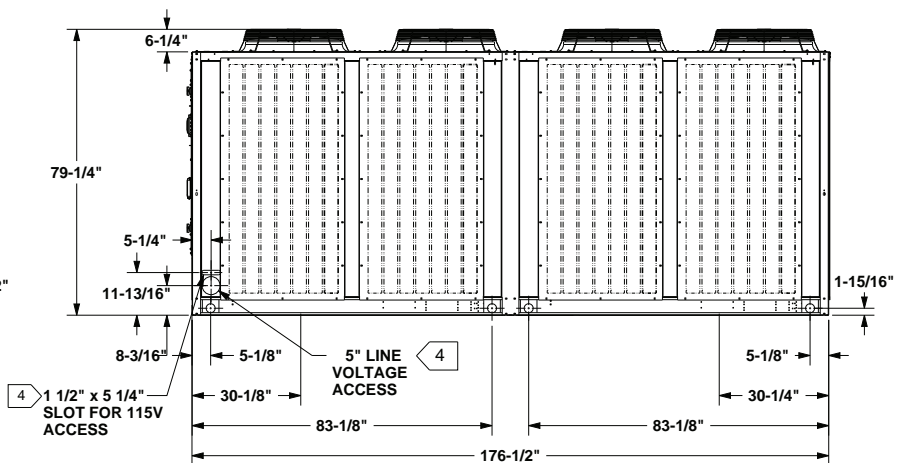
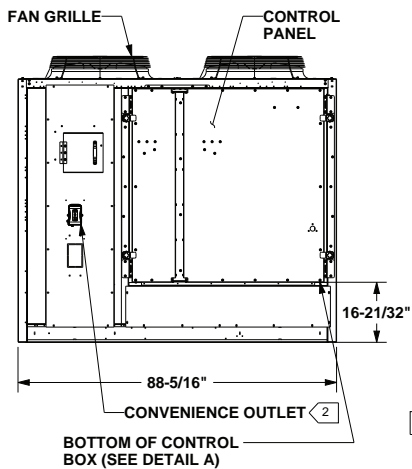



Dimensions and Weights

Figure 13. Air-cooled condenser connections — 80 ton

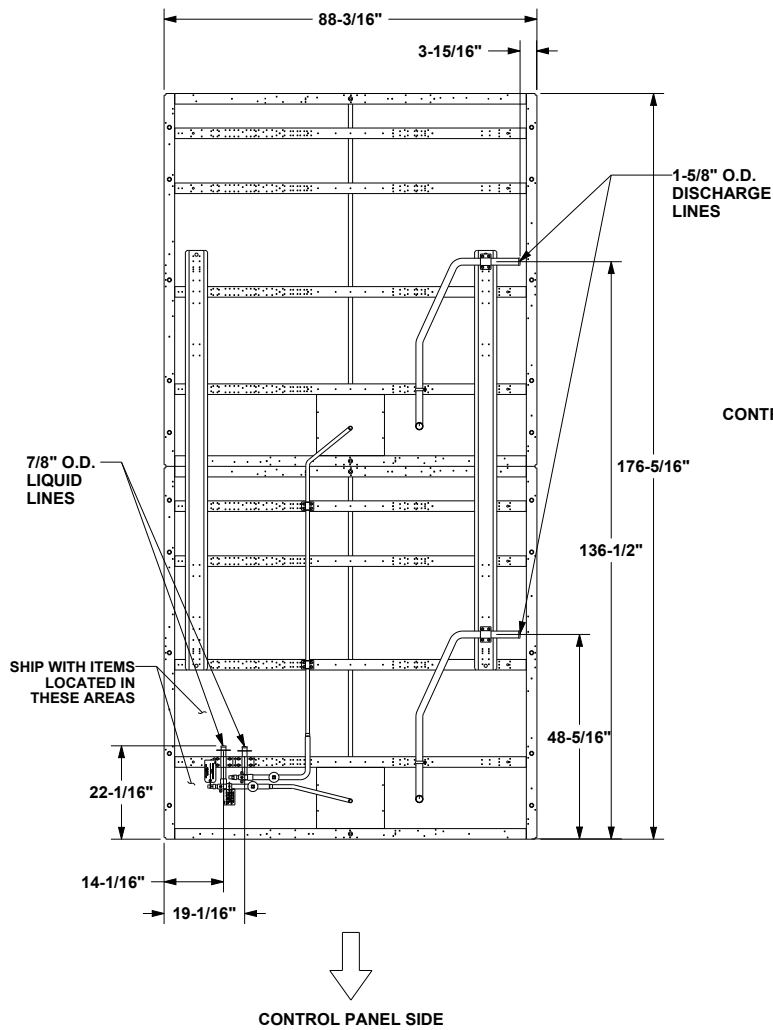

PLAN VIEW OF UNIT
CONNECTION DRAWING

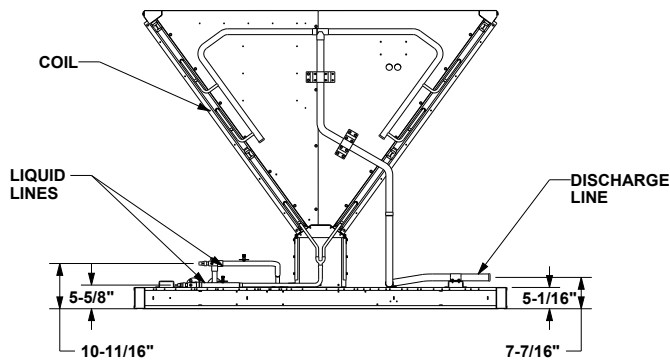

CONTROL PANEL SIDE VIEW OF UNIT
CONNECTION DRAWING

NOTES:

1. VERIFY WEIGHT, CONNECTION, AND ALL DIMENSIONS WITH INSTALLER DOCUMENTS BEFORE INSTALLATION.
2. DUAL CIRCUIT UNIT REQUIRES TWO SEPARATE LINES SETS (TWO SUCTION) LINES AND TWO LIQUID LINES).

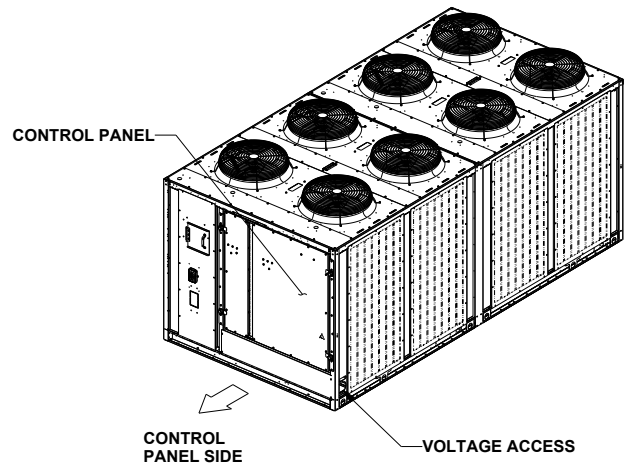

ORIENTATION VIEW OF UNIT
ISOMETRIC DRAWING

Figure 14. Air-cooled condenser — 100 and 120 tons

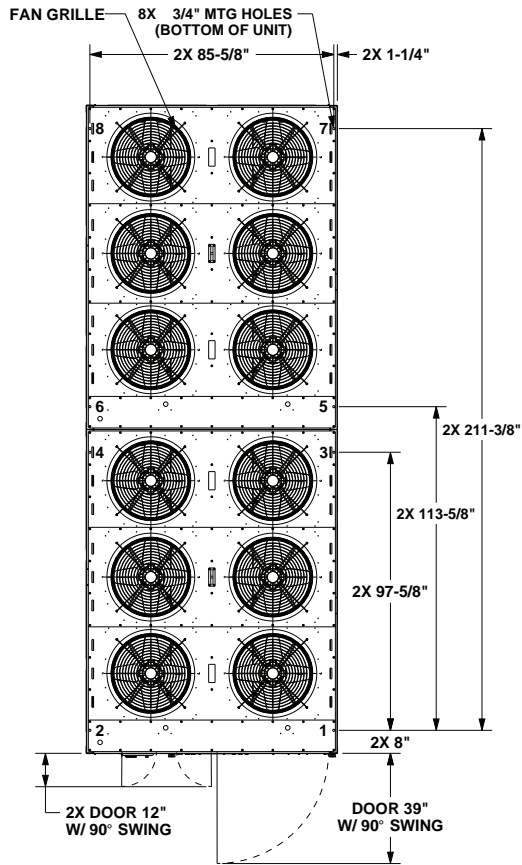

NOTES:

1. SEE CONNECTION DRAWING FOR CONNECTION LOCATION AND SIZES.
2. OPTIONS ONLY COME ON SELECTED UNITS.
3. FRONT AND BACK OF UNIT CLEARANCE 72" . LEFT AND RIGHT SIDE OF UNIT CLEARANCE 48"
4. VOLTAGE ACCESS HOLES IN OUTER PANEL MUST BE COVERED AFTER UNIT INSTALLATION

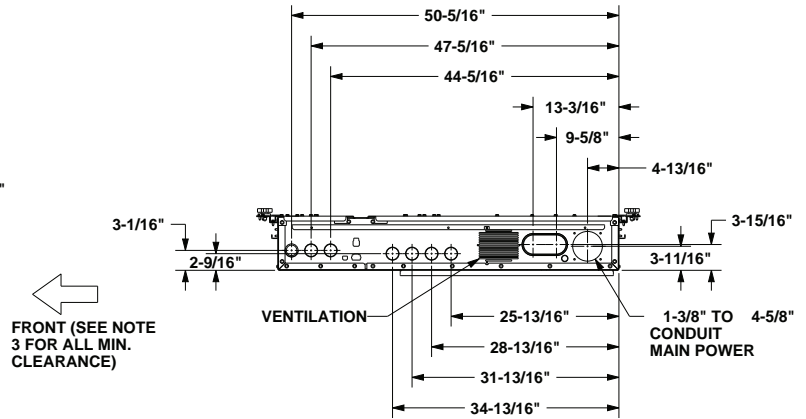

DETAIL A

CONTROL BOX BOTTOM

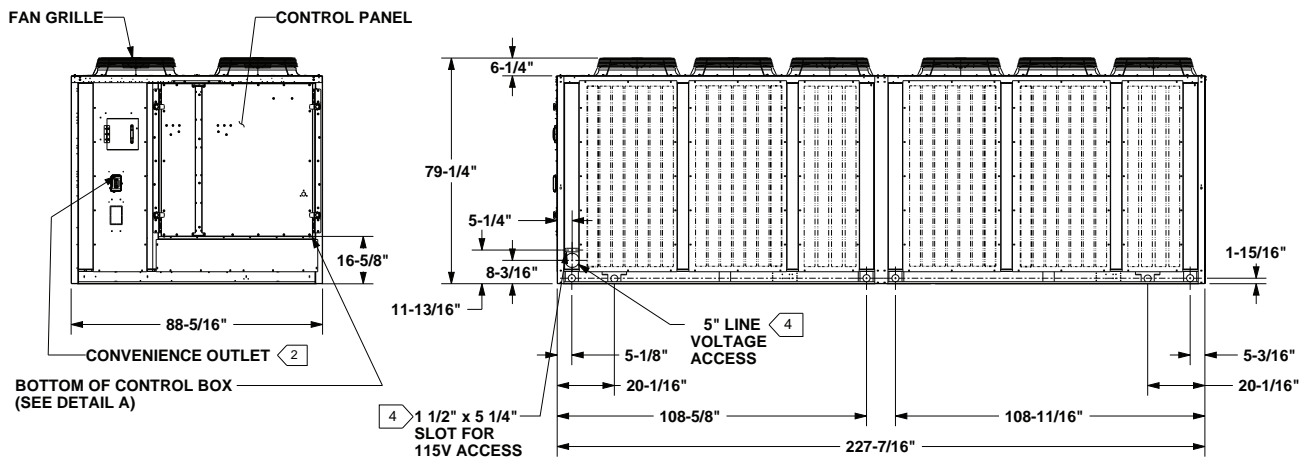



Dimensions and Weights

Figure 15. Air-cooled condenser connections — 100 and 120 tons

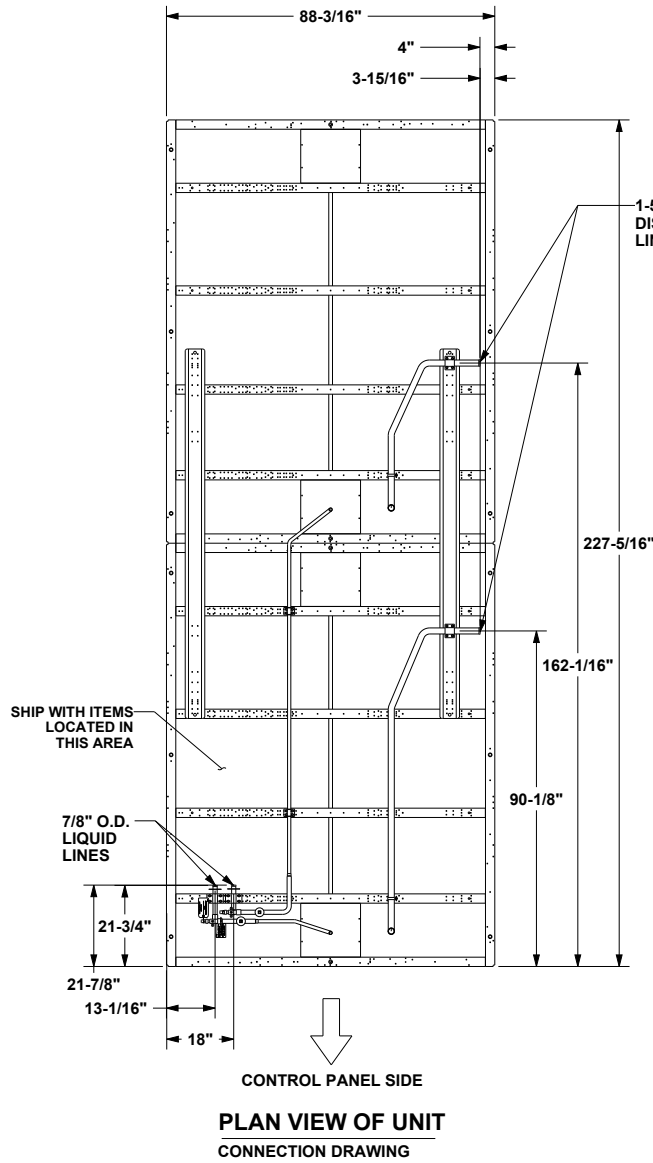

NOTES:

- 1. VERIFY WEIGHT, CONNECTION, AND ALL DIMENSIONS WITH INSTALLER DOCUMENTS BEFORE INSTALLATION.
- 2. DUAL CIRCUIT UNIT REQUIRES TWO SEPARATE LINES SETS (TWO SUCTION) LINES AND TWO LIQUID LINES).

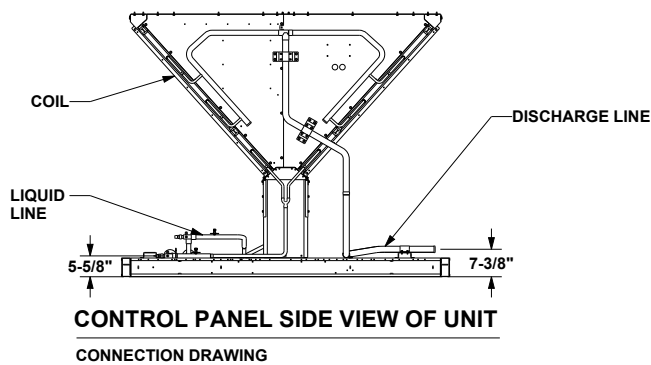
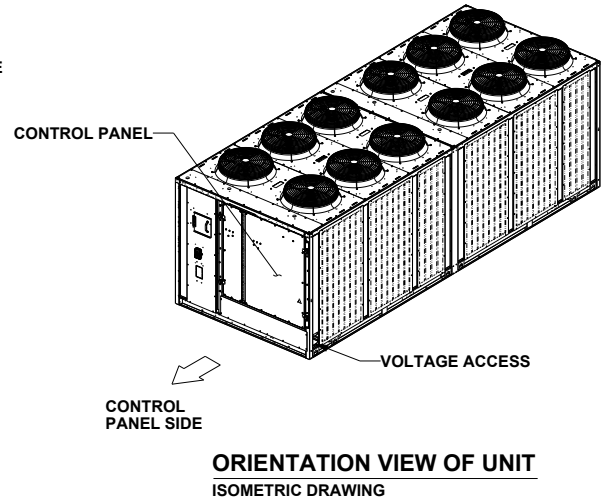

100 AND 120 TON UNITS
DIMENSION CONNECTION DRAWING

Unit Weights

Table 3. CAUK air-cooled condenser weights

Unit Size (tons)	R-454B
20	1389
25	1439
30	1437
40	1964
50	2276
60	2292
80	3319
100	4067
120	4558



Installation Mechanical

Location Requirements

Isolation

To minimize unit sound and vibration transmission, one of the following installation methods should be used:

- Install the unit directly on an isolated (detached) concrete pad or on isolated concrete footings located at each unit load point. OR
- Install the optional neoprene or spring isolators at each mounting location. See “Unit Isolation,” p. 31.

Foundation

Ground Level Installation

- If the unit is installed at ground level, elevate it above the snow line.
- Provide concrete footings at each support location or a slab foundation for support.
- See in Dimensions and Weights chapter for the unit operating weights.
- See “Unit Mounting,” p. 30 for mounting locations and point loading weights when constructing the footing foundation.
- Anchor the unit to the footings or slab using hold down bolts or isolators.
- Isolators should be installed to minimize the transmission of vibrations into the building. See “Unit Isolation,” p. 31.

Rooftop Applications

For rooftop applications, ensure the roof is strong enough to support the unit. See in Dimensions and Weights chapter for the unit operating weights.

Anchor the unit to the roof with hold-down bolts or isolators. Follow the instructions in “Unit Isolation,” p. 31 for proper isolator placement and installation.

Check with a roofing contractor for proper waterproofing procedures.

Leveling the Unit

Before tightening the mounting bolts, level the unit carefully. Use the unit base rail as a reference. Level the unit to within 1/4 inch over its entire length. Use shims if non-adjustable isolators (neoprene) are used.

If adjustable isolators (spring) are used, ensure that the proper isolator housing clearance is maintained while leveling the unit. Isolators are identified by color and/or an isolator part number. Shims under the isolators may be required if the unit cannot be leveled using the isolator leveling bolt.

Rigging and Lifting

⚠ WARNING

Heavy Object!

Failure to follow instructions below could result in unit dropping which could result in death or serious injury, and equipment or property-only damage. Ensure that all the lifting equipment used is properly rated for the weight of the unit being lifted. Each of the cables (chains or slings), hooks, and shackles used to lift the unit must be capable of supporting the entire weight of the unit. Lifting cables (chains or slings) may not be of the same length. Adjust as necessary for even unit lift.

⚠ WARNING

Improper Unit Lift!

Failure to properly lift unit in a LEVEL position could result in unit dropping and possibly crushing operator/technician which could result in death or serious injury, and equipment or property-only damage. Test lift unit approximately 24 inches (61 cm) to verify proper center of gravity lift point. To avoid dropping of unit, reposition lifting point if unit is not level.

See in Dimensions and Weights chapter for unit weights. See for center-of-gravity information.

1. Rig condensing unit as shown in Figure 16, p. 29 and Figure 17, p. 29. Attach adequate strength lifting slings to all four lifting brackets. Do not use cables, chains, or slings except as shown.
2. Install spreader bars as shown in Figure 16, p. 29 to protect the unit and to facilitate a uniform lift. Minimum distance between lifting hook and top of unit is 7 feet.
3. Test-lift the unit to ensure it is properly rigged and balanced. Make any necessary rigging adjustments.
4. Lift the unit and position into place.

Figure 16. Rigging and center-of-gravity data

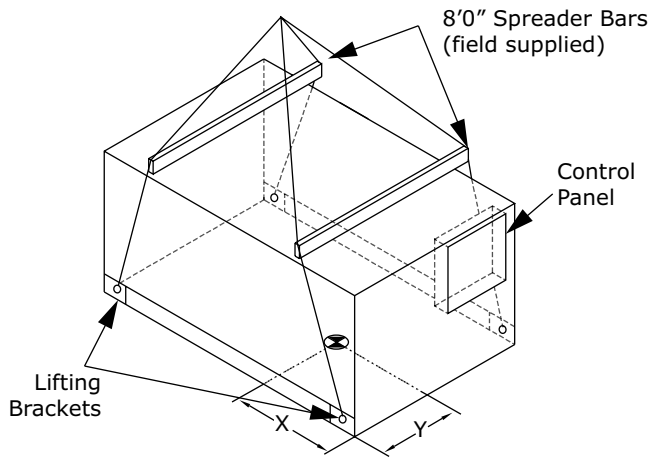

Note: See lifting bracket location figure for more detail.

Figure 17. Lifting bracket locations

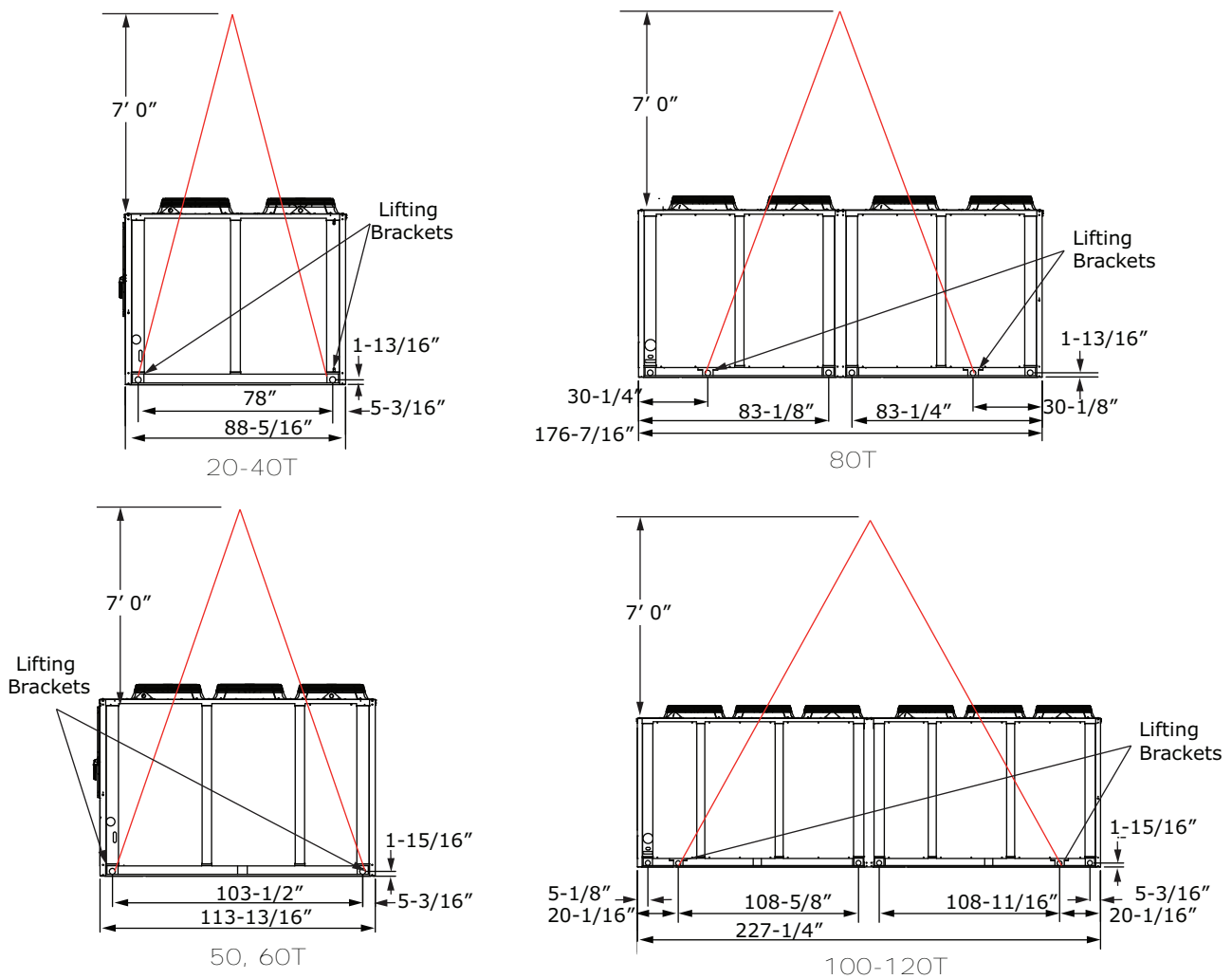

Table 4. CAUK center-of-gravity

Tons	CG Locations	
	X	Y
20	36.3	32.1
25	36.8	31.9
30	36.4	32
40	40.8	47.1
50	49.5	46.6
60	49.7	46.6
80	82.7	54.4
100	108.6	54
120	109.7	52.7

Unit Mounting

Figure 18. Mounting location

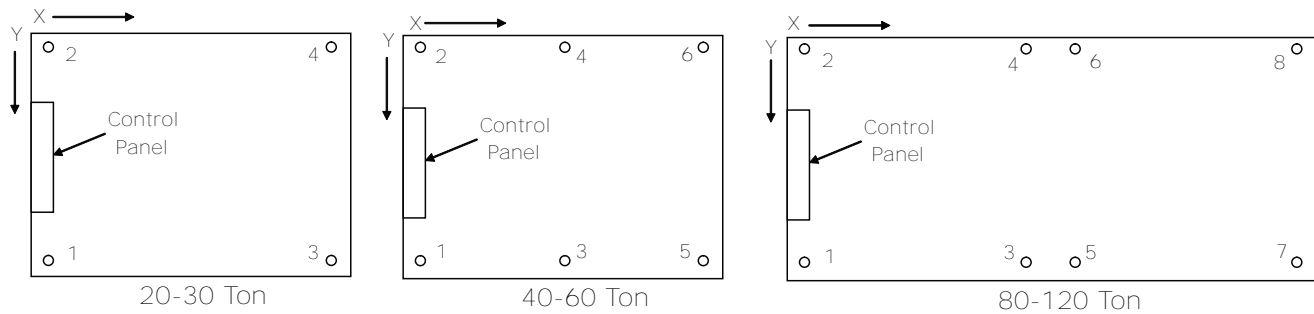

Table 5. Isolator mounting locations (in)

Unit Size (tons)		Mounting Location							
		1	2	3	4	5	6	7	8
20/25/30	X	8.00	8.00	80.125	80.125	-	-	-	-
	Y	58.75	1.25	58.75	1.25	-	-	-	-
40	X	8.00	8.00	44.125	44.125	80.25	80.25	-	-
	Y	87.125	1.25	87.125	1.25	87.125	1.25	-	-
50/60	X	8.00	8.00	56.875	56.875	105.75	105.75	-	-
	Y	87.125	1.25	87.125	1.25	87.125	1.25	-	-
80	X	8.00	8.00	80.125	80.125	108.125	108.125	168.25	168.25
	Y	87.125	1.25	87.125	1.25	87.125	1.25	87.125	1.25
100/120	X	8.00	8.00	105.625	105.625	121.625	121.625	219.25	219.25
	Y	87.125	1.25	87.125	1.25	87.125	1.25	87.125	1.25

Table 6. CAUK point loading weights (lbs)

Unit Size (tons)	Mounting Location							
	1	2	3	4	5	6	7	8
20	448.3	396.6	297.9	246.2	-	-	-	-
25	456.1	408.7	310.8	263.4	-	-	-	-
30	460.1	410.6	307.9	258.4	-	-	-	-
40	394.0	350.2	349.2	305.4	304.4	260.6	-	-
50	486.5	443.0	401.1	357.6	315.7	272.2	-	-

Table 6. CAUK point loading weights (lbs) (continued)

Unit Size (tons)	Mounting Location							
	1	2	3	4	5	6	7	8
60	487.4	443.7	403.8	360.2	320.3	276.6	-	-
80	601.2	403.4	525.4	327.5	495.9	298.1	432.7	234.9
100	672.7	440.0	628.3	395.7	621.1	388.4	576.7	344.0
120	725.3	498.6	686.3	459.6	679.9	453.2	640.9	414.2

Unit Isolation

Neoprene Isolators (20 to 60 Ton units)

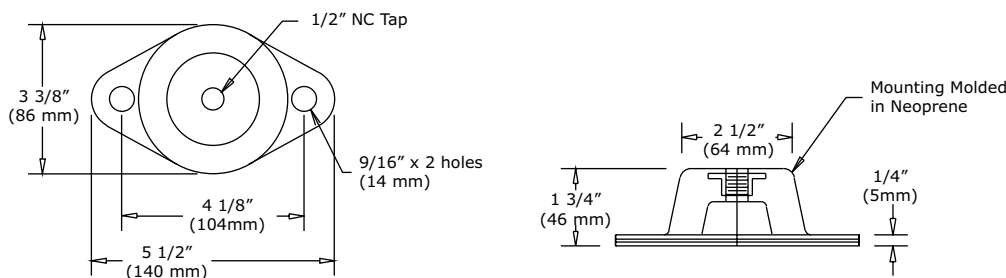
Figure 19. Neoprene isolators (20 to 60 ton units only)

Table 7. CAUK neoprene isolator selection (20 to 60 ton units only)

Unit Size (tons)	Mounting Location					
	1	2	3	4	5	6
20	R-3-RED	R-3-RED	R-3-RED	R-3-RED	—	—
25	R-3-RED	R-3-RED	R-3-RED	R-3-RED	—	—
30	R-3-RED	R-3-RED	R-3-RED	R-3-RED	—	—
40	R-3-RED	R-3-RED	R-3-RED	R-3-RED	R-3-RED	R-3-RED
50	R-3-RED	R-3-RED	R-3-RED	R-3-RED	R-3-RED	R-3-RED
60	R-3-RED	R-3-RED	R-3-RED	R-3-RED	R-3-RED	R-3-RED

⚠ WARNING

Heavy Object!

Failure to follow instructions could result in death or serious injury.

Use solid type blocks, such as 4 X 4 inch wood blocks or similar material, to prevent collapsing. Keep hands and other body limbs clear of elevated base rail while installing isolators.

Install the neoprene isolators at each unit mounting (load) point, using the following procedure:

- Elevate the unit (one side at a time) to allow access to the base rail mounting holes.
- Align the mounting holes in the base rail of the unit with the holes in the top of the appropriate isolator.
- Install a 1/2-inch NC bolt (field supplied) through the base rail of the unit into the threaded bolt hole of the isolator. Position the isolator to allow access to the mounting holes in the base of the isolator, then tighten securely.
- Lower the unit and isolator onto the mounting surface. The maximum isolator deflection should be approximately 1/4-inch.
- Secure the isolator to the mounting surface using the base holes in the isolator.
- Level the unit carefully. See the “Leveling the Unit,” p. 28.
- After the unit is level, tighten the isolator base mounting bolts to secure them to the mounting surface.

Spring Isolators (20 to 120 Ton units)

Figure 20. Spring isolators

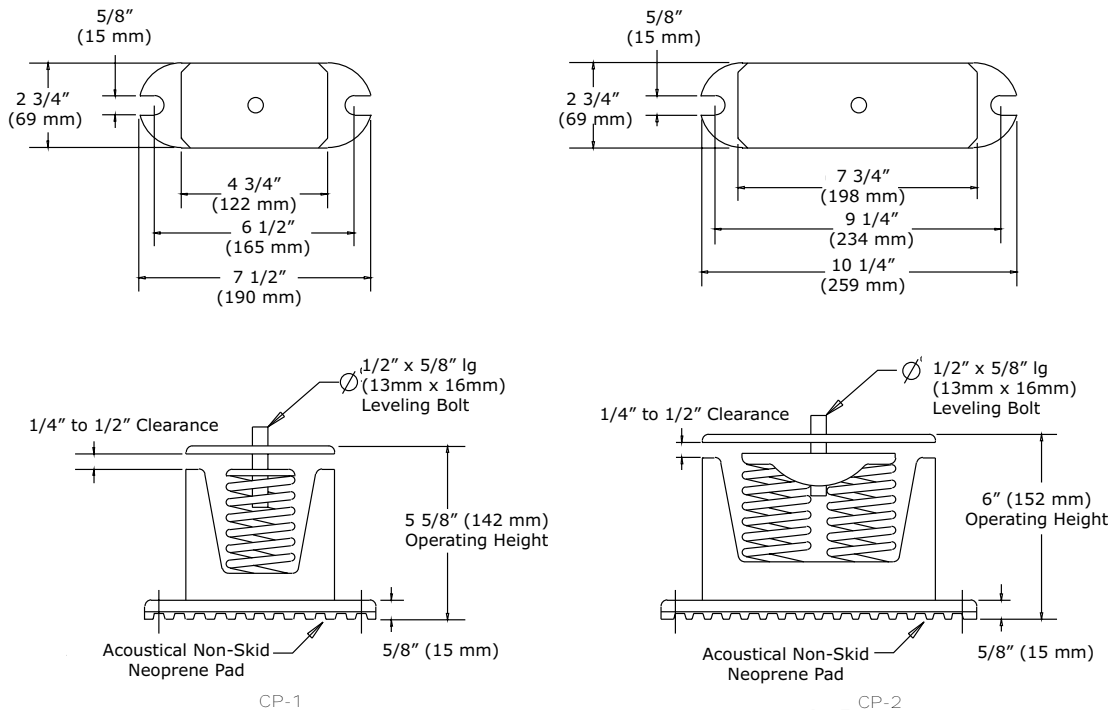

Table 8. CAUK spring isolator selection

Unit Size (tons)	Mounting Location							
	1	2	3	4	5	6	7	8
20	CP-1D-510	CP-1D-510	CP-1D-340	CP-1D-340	—	—	—	—
25	CP-1D-510	CP-1D-510	CP-1D-340	CP-1D-340	—	—	—	—
30	CP-1D-510	CP-1D-510	CP-1D-340	CP-1D-340	—	—	—	—
40	CP-1D-510	CP-1D-510	CP-1D-510	CP-1D-340	CP-1D-340	CP-1D-340	—	—
50	CP-1D-510	CP-1D-510	CP-1D-510	CP-1D-510	CP-1D-340	CP-1D-340	—	—
60	CP-1D-510	CP-1D-510	CP-1D-510	CP-1D-510	CP-1D-340	CP-1D-340	—	—
80	CP-1D-675	CP-1D-510	CP-1D-675	CP-1D-340	CP-1D-510	CP-1D-340	CP-1D-510	CP-1D-340
100	CP-1D-900	CP-1D-510	CP-1D-675	CP-1D-510	CP-1D-675	CP-1D-510	CP-1D-675	CP-1D-510
120	CP-1D-900	CP-1D-510	CP-1D-900	CP-1D-510	CP-1D-900	CP-1D-510	CP-1D-675	CP-1D-510

⚠ WARNING
Heavy Object!
 Failure to follow instructions could result in death or serious injury.
 Use solid type blocks, such as 4 X 4 inch wood blocks or similar material, to prevent collapsing. Keep hands and other body limbs clear of elevated base rail while installing isolators.

Install the spring isolators at each unit mounting (load) point, using the following procedure:

1. Elevate the unit (one side at a time) to allow access to the base rail mounting holes.

2. Align the mounting holes in the base rail of the unit with the positioning pin in the top of the appropriate isolator.
3. Position the isolator to allow access to the mounting holes in the base of the isolator.
4. Lower the unit onto the isolator. The positioning pin on the isolator must engage into the hole of the base rail. The clearance between the upper and lower isolator housings should be approximately 1/4 to 1/2-inch. A clearance greater than 1/2-inch indicates that shims are required to level the unit. See [“Leveling the Unit,” p. 28.](#)
5. Make minor clearance adjustments by turning the isolator leveling bolt clockwise to increase the clearance and counterclockwise to decrease the

clearance. If proper isolator clearance cannot be obtained by turning the leveling bolt, level the isolators themselves. A 1/4-inch variance in elevation is acceptable.

6. Secure the isolator to the mounting surface using the base holes in the isolator.
7. After unit is level, tighten isolator base mounting bolts to secure them to the mounting surface.

Installation

General Unit Requirements

The checklist listed below is a summary of the steps required to successfully install a commercial air cooled condenser. This checklist is intended to acquaint the installing personnel with what is required in the installation process. It does not replace the detailed instruction called out in the applicable sections of this manual.

- Verify that the power supply complies with the unit nameplate specifications.
- Check the unit for shipping damage and material shortage. If damage or shortage is found, file a freight claim and notify Trane office.
- Verify installation location of the unit will provide the required clearance for proper operation.
- Install appropriate isolators, if required.

Refrigerant Piping Requirements

Note: See *“Refrigerant Piping Components,” p. 33* and *“Refrigerant Piping,” p. 36* for recommended line components and guidelines.

- Install properly sized liquid line(s) between the liquid line connections on the unit and the evaporator.
- Install refrigerant rated shutoff valves in the liquid line (s) to isolate the filter drier(s) for service.
- Install a properly sized filter drier in each liquid line.
- Install properly sized discharge (hot gas) line(s) between the discharge line connections on the unit and the compressor unit.
- Leak test the system per *“Leak Testing Procedure,” p. 38*.

Refrigerant Piping Components

For recommended components, see *RAUJ Split Systems (20 to 120Tons) R-410A Refrigerant Microchannel Condensers Application Guide (SS-APG012*-EN)* and *R-454B Refrigerant Microchannel Condensers Application Guide (SS-APG018*-EN)*.

Liquid Line Components

Filter driers and valves (expansion valves, charging valves, etc.) should be provided in the liquid lines just before the evaporator. Minimize the use of valves, reducers and tube bends as much as possible to avoid excessive pressure drop before the expansion valve.

Liquid Line Filter/Filter Drier (Field Supplied)

Install the filter drier in the liquid line as close as possible to the expansion valve. Locate them upstream of the moisture indicator and solenoid valve (if applicable).

Liquid Line Moisture Indicator

To aid in troubleshooting, charging and servicing the system, install moisture indicators in the liquid lines near the evaporator, down stream of the liquid line drier between the solenoid valve (if applicable) and the expansion valve.

Liquid Line Solenoid Valves

NOTICE
Equipment Damage!
Do not use solenoid valve as a pumpdown device as it could result in equipment damage.

Liquid line solenoid valves are not recommended on units when they are connected to DX coils. Liquid line solenoid valves are recommended for refrigerant migration control when they are connected to an EVP chiller and should be connected as described in the *“Electrical,” p. 39*.

Thermostatic Expansion Valve (TXV)

Trane recommends a balance-ported externally equalized valve in order to maintain satisfactory superheat control down to lower valve loading conditions and to compensate for pressure drops between the expansion valve and superheat control point (evaporator refrigerant outlet).

In order to get proper refrigerant distribution into the coil, an expansion valve is required for each coil distributor.

Table 9. Expansion valve selection, any BPHE R-410A

Min Tonnage	Max Tonnage	Selection(a)	Alternate(a)
1.5	2	BBIZE-1-1/2-GA	ERZE-1-1/2-GA
2	3	BBIZE-2-GA	ERZE-2-GA
2.5	4	BBIZE-3-GA	ERZE-3-GA
3.5	5.5	BBIZE-4-GA	ERZE-4-GA
4.5	6.5	BBIZE-5-GA	ERZE-5-GA
5.5	7.5	BBIZE-6-GA	ERZE-6-GA
6.5	10.5	BBIZE-8-GA	ERZE-8-GA



Installation Mechanical

Table 9. Expansion valve selection, any BPHE R-410A (continued)

Min Tonnage	Max Tonnage	Selection(a)	Alternate(a)
8.5	13.5	BBIZE-12-1/2-GA	ERZE-12-1/2-GA
11	16.5	BBIZE-15-GA	ERZE-15-GA
13	22	OZE-20-GA	—
17	26	OZE-25-GA	—
20.5	39	OZE-35-GA	—
30.5	59	OZE-50-GA	—
45.5	70	OZE-60-GA	—

Table 10. Expansion valve selection, any BPHE R-454B

Min Tonnage	Max Tonnage	Manufacturer	Selection(a)	Trane Part
13.0	22.0	Sporlan	OYE 20-CP	VAL21152
17.0	26.0	Sporlan	OYE 25-CP	VAL21153
20.5	39.0	Sporlan	OYE 35-CP	VAL21805
30.5	59.0	Sporlan	OYE 55-CP	VAL21806

(a) Valve part numbers with "-ZGA" in place of "-GA", may be used interchangeably.

Table 11. Expansion valve selection, 20 to 60 ton MCHE (30% bleed) R-410A

Min Tonnage	Max Tonnage	Manufacturer	Selection(a)	Trane Part
2	3	Sporlan	ERZE-1-1/2-ZGA (BP/15)	VAL10487
2.5	3.5	Sporlan	ERZE-2-ZGA (BP/30)	VAL10488
3.5	5	Sporlan	ERZE-3-ZGA (BP/30)	VAL10489
4.5	7	Sporlan	ERZE-4-ZGA (BP/30)	VAL10490
6	8.5	Sporlan	ERZE-5-ZGA (BP/30)	VAL10491
7	10	Sporlan	ERZE-6-ZGA (BP/30)	VAL10492
8	13.5	Sporlan	ERZE-8-ZGA (BP/30)	VAL10493
11	17.5	Sporlan	ERZE-12-1/2-ZGA (BP/30)	VAL10494
14	21.5	Sporlan	ERZE-15-ZGA (BP/30)	VAL10495
17	28.5	Sporlan	OZE-20-ZGA (BP/30)	VAL10496
22	30	Sporlan	OZE-25-ZGA (BP/30)	VAL10497

Table 12. Expansion valve selection, 20 to 60 ton MCHE (30% bleed) R-454B

Min Tonnage	Max Tonnage	Manufacturer	Selection(a)	Trane Part
2.5	3.0	Sporlan	BBIYE 2.5-CP (BP/30)	VAL21648
3.5	5.0	Sporlan	BBIYE 3-CP (BP/30)	VAL21649
4.5	7.0	Sporlan	BBIYE 4.5-CP (BP/30)	VAL21650
6.0	8.5	Sporlan	BBIYE 6-CP (BP/30)	VAL 21651
7.0	10.0	Sporlan	BBIYE 7-CP (BP/30)	VAL21652
8.0	13.5	Sporlan	BBIYE 8.5-CP (BP/30)	VAL21653
11.0	17.5	Sporlan	BBIYE 11.5-CP (BP/30)	VAL21654
12.5	19.0	Sporlan	BBIYE 15.5-CP (BP/30)	VAL21655
14.0	21.5	Sporlan	BBIYE 18-CP (BP/30)	VAL21656
17.0	28.5	Sporlan	OYE 20-CP (BP/30)	VAL21657
22.0	30.0	Sporlan	OYE 25-CP (BP/30)	VAL21658

(a) Valve part numbers with "-ZGA" in place of "-GA", may be used interchangeably.

Table 13. Expansion valve selection, 80 to 120 ton MCHE (15% bleed) R-410A

Min Tonnage	Max Tonnage	Manufacturer	Selection(a)	Trane Part
2	2.5	Sporlan	ERZE-1-1/2-ZGA (BP/15)	—
2.5	3	Sporlan	ERZE-2-ZGA (BP/15)	—
3	4.5	Sporlan	ERZE-3-ZGA (BP/15)	—
4	6	Sporlan	ERZE-4-ZGA (BP/15)	—
5	7.5	Sporlan	ERZE-5-ZGA (BP/15)	VAL10579
6	9	Sporlan	ERZE-6-ZGA (BP/15)	VAL10580
7	12	Sporlan	ERZE-8-ZGA (BP/15)	VAL10581
9.5	15.5	Sporlan	ERZE-12-1/2-ZGA (BP/15)	VAL10582
12.5	19	Sporlan	ERZE-15-ZGA (BP/15)	VAL10583
15	25	Sporlan	OZE-20-ZGA (BP/15)	VAL10584
19.5	30	Sporlan	OZE-25-ZGA (BP/15)	VAL10585
23.5	45	Sporlan	OZE-35-ZGA (BP/15)	VAL10586
35	68	Sporlan	OZE-50-ZGA (BP/15)	VAL10587
52.5	70	Sporlan	OZE-60-ZGA (BP/15)	VAL10588

Table 14. Expansion valve selection, 80 to 120 ton MCHE (15% bleed) R-454B

Min Tonnage	Max Tonnage	Manufacturer	Selection(a)	Trane Part
2.5	3.0	Sporlan	BBIYE 2.5-CP (BP/15)	VAL21660
3.0	4.5	Sporlan	BBIYE 3-CP (BP/15)	VAL21661
4.0	6.0	Sporlan	BBIYE 4.5-CP (BP/15)	VAL21662
5.0	7.5	Sporlan	BBIYE 6-CP (BP/15)	VAL21663
6.0	9.0	Sporlan	BBIYE 7-CP (BP/15)	VAL21664
7.0	12.0	Sporlan	BBIYE 8.5-CP (BP/15)	VAL21665
9.5	15.5	Sporlan	BBIYE 11.5-CP (BP/15)	VAL21666
12.5	19.0	Sporlan	BBIYE 15.5-CP (BP/15)	VAL21667
14.0	21.5	Sporlan	BBIYE 18-CP (BP/15)	VAL21668
15.0	25.0	Sporlan	OYE-20-CP (BP/15)	VAL21669
19.5	30.0	Sporlan	OYE-25-CP (BP/15)	VAL21670
23.5	45.0	Sporlan	OYE-35-CP (BP/15)	VAL21671
35.0	68.0	Sporlan	OYE-55-CP (BP/15)	VAL21672

(a) Valve part numbers with "-ZGA" in place of "-GA", may be used interchangeably.

Ball Shutoff Valves

The ball shutoff valve allows for isolation of the filter/filter drier for easier core replacement.

Two ball shutoff valves equal to the OD tubing size for liquid line are required.

Discharge Line Components

Field supplied hot gas mufflers, pipe anchors, single or double risers, oil traps, etc. as applicable, should be provide to prevent excessive line vibration and assure proper oil return to the compressor for proper system operation.

A field supplied discharge "shutoff" valve in each hot gas line near the condenser is recommended to facilitate

refrigerant storage in the condenser during service procedures.

A "constant drain" oil trap is illustrated below and can be used as an alternative to a double riser application. The constant drain oil trap assures adequate oil return to the suction line even at part load conditions.

Figure 21. Hot gas line components

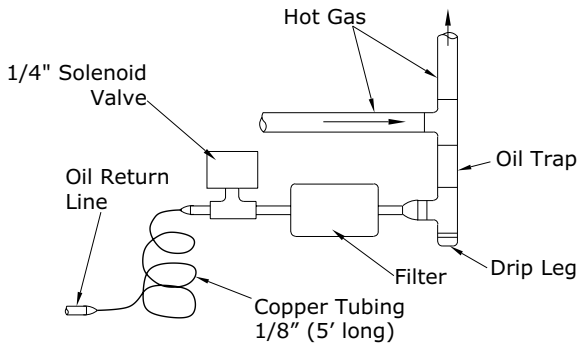

Refrigerant Piping

NOTICE

Compressor Damage!

POE oil is hygroscopic – it absorbs water directly from the air. This water is nearly impossible to remove from the compressor oil and can result in compressor failures.

To prevent POE oil from absorbing water, the system should not remain open for longer than necessary. When open, dry nitrogen should flow through the piping. Only new oil containers should be used for service and maintenance. Always use the smallest container size required for the job requirements. Always leave the oil container tightly sealed until time of use. Do not reuse oil that has been opened.

Refrigerant piping must be properly sized and applied. These two factors have a very significant effect on both system performance and reliability.

Note: Use Type “L” refrigerant grade copper tubing only.

Refrigerant Piping should be sized and laid out according to the job plans and specifications. This should be done when the system components are selected.

The primary objective when sizing refrigerant piping for this unit is to make refrigerant line sizes as small as possible while avoiding excessive refrigerant pressure drops.

Sizing refrigerant lines as small as possible minimizes the required refrigerant charge and maximizes compressor life.

See *Tube Size and Component Selection RAUJ Split Systems (20 to 120Tons) R-410A Refrigerant Microchannel Condensers Application Guide (SS-APG012*-EN)* and *R-454B Refrigerant Microchannel Condensers Application Guide (SS-APG018*-EN)*.

Liquid Line Piping

Basic sizing parameters with the system operating at full load for liquid lines are:

- Maximum Liquid velocity: 600 fpm
- Maximum allowable pressure drop: 7 psig (1°F)

As the pressure drop in the liquid line increases, the potential for liquid flashing, due to reduced refrigerant

pressure corresponding to a reduced liquid temperature (subcooling), increases. Under these conditions, liquid lines exposed to high surrounding ambient temperatures must be insulated.

Note: Adding refrigerant to a system with improperly sized refrigerant lines will only decrease system performance and reliability and accentuate poor operating condition.

Isolate all refrigerant lines from the building. This prevents transferring line vibration to the structure. Do not secure the lines rigidly to the building at any point since this will defeat the isolation system of the unit.

See connection drawings in Dimension and Weights chapter for refrigerant line size connections and locations. Connect the liquid line piping to the stubs provided at the liquid line shutoff valves.

Note: The installer must cut an appropriately-sized opening in the unit sheet metal for the refrigerant piping entrance into the unit.

Discharge (Hot Gas) Lines

Discharge lines should be pitched downward 1/2 inch for each 10 feet of horizontal run in the direction of hot gas flow and away from the compressor. Insulate any portion of the discharge piping that is exposed to outdoor ambient temperature.

Discharge line sizing is based on minimum velocity required for good oil movement in system.

Basic discharge line parameters are:

- Maximum allowable pressure drop: 6 psig
- Maximum velocity: 3500 fpm

Minimum velocities at Minimum Load:

- Horizontal Lines: 500 fpm
- Vertical Lines: See Table 15, p. 36.

A double riser system may be necessary to meet the discharge line velocity requirements.

When either a single or double discharge riser is used, the line should drop well below the discharge outlet of the compressor before starting the vertical rise to prevent the possibility of refrigerant draining back to the compressor during the “Off” cycle.

Table 15. Minimum vertical line velocities

Line Dia.	Minimum Velocity (fpm)	Line Dia.	Minimum Velocity (fpm)
7/8"	470	2-1/8"	750
1-1/8"	540	2-5/8"	825
1-3/8"	600	3-1/8"	915
1-5/8"	650	3-5/8"	975

Final Refrigerant Pipe Connections

To access the refrigerant pipe connections, remove the louvered side grills. See connection drawings in “Unit Dimensions,” p. 13.

These condensing units are shipped with a Nitrogen holding charge. Install pressure gauges to the appropriate access valve(s) and take a reading.

- If no pressure is present, see “Leak Testing Procedure,” p. 38.
- If pressure is present, relieve the pressure before attempting to unsweat the “seal” caps.
- If refrigerant connections are not capped, but are “spun-end” tubes, use a tubing cutter to remove the end from the pipe.

NOTICE

Equipment Damage!

Drilling or sawing pipe stubs could introduce copper chips into the system and cause equipment damage. Do not drill a hole in the seal caps or saw the ends of pipe stubs.

Brazing Procedures

⚠ WARNING

Explosion Hazard and Deadly Gases!

Failure to follow all proper safe refrigerant handling practices could result in death or serious injury. Never solder, braze or weld on refrigerant lines or any unit components that are above atmospheric pressure or where refrigerant may be present. Always remove refrigerant by following the guidelines established by the EPA Federal Clean Air Act or other state or local codes as appropriate. After refrigerant removal, use dry nitrogen to bring system back to atmospheric pressure before opening system for repairs. Mixtures of refrigerants and air under pressure may become combustible in the presence of an ignition source leading to an explosion. Excessive heat from soldering, brazing or welding with refrigerant vapors present can form highly toxic gases and extremely corrosive acids.

⚠ WARNING

Explosion Hazard!

Failure to follow these instructions could result in death or serious injury or equipment or property-only damage.

Use only dry nitrogen with a pressure regulator for pressurizing unit. Do not use acetylene, oxygen or compressed air or mixtures containing them for pressure testing. Do not use hydrogen mixtures containing refrigerant and air above atmospheric pressure for pressure testing as they may become flammable and could result in an explosion. Refrigerant, when used as a trace gas should only be mixed with dry nitrogen for pressurizing units.

Proper brazing techniques are essential when installing refrigerant piping. The following factors should be kept in mind when forming sweat connections.

- When copper is heated in the presence of air, copper oxide forms. To prevent copper oxide from forming inside the tubing during brazing, sweep an inert gas, such as dry nitrogen, through the tubing. Nitrogen displaces air in the tubing and prevents oxidation of the interior surfaces. A nitrogen flow of one to three cubic feet per minute is sufficient to displace the air. Use a pressure regulating valve or flow meter to control the flow.
- Ensure that the tubing surfaces to be brazed are clean, and that the ends of the tubes have been carefully reamed to remove any burrs.
- Make sure the inner and outer tubes of the joint are symmetrical and have a close clearance, providing an easy slip fit. If the joint is too loose, the tensile strength of the connection will be significantly reduced. The overlap distance should be equal to the diameter of the inner tube.
- Wrap the body of each refrigerant line component with a wet cloth to keep it cool during brazing. Move any tube entrance grommets away for the brazing area.
Note: Use 40 to 45% silver brazing alloy (BAG-7 or BAG-28) on dissimilar metals. Use BCup-6 brazing alloy on copper to copper joints.
- If flux is used, apply it sparingly to the joint. Excessive flux can enter the system which will contaminate the refrigerant system.
- Apply heat evenly over the length and circumference of the joint to draw the brazing material into the joint by capillary action. Remove the brazing rod and flame from the joint as soon as a complete fillet is formed to avoid possible restriction in the line.
- Visually inspect the connection after brazing to locate any pin holes or crevices in the joint. The use of a mirror may be required, depending on the joint location.

Leak Testing Procedure

⚠ WARNING

Explosion Hazard!

Failure to follow these instructions could result in death or serious injury or equipment or property-only damage.

Use only dry nitrogen with a pressure regulator for pressurizing unit. Do not use acetylene, oxygen or compressed air or mixtures containing them for pressure testing. Do not use hydrogen mixtures containing refrigerant and air above atmospheric pressure for pressure testing as they may become flammable and could result in an explosion. Refrigerant, when used as a trace gas should only be mixed with dry nitrogen for pressurizing units.

⚠ WARNING

Explosion Hazard!

Failure to follow safe leak test procedures below could result in death or serious injury or equipment or property-only-damage.

Never use an open flame to detect gas leaks. Use a leak test solution for leak testing.

When leak testing a refrigerant system, observe all safety precautions.

Trane condensing units are shipped with a nitrogen holding charge. If there is no pressure, the unit must be leak tested to determine the location of leak.

Note: *These service procedures require working with refrigerant, Do NOT release refrigerant to the atmosphere! The service technician must comply with all federal, state, and local laws.*

Use refrigerant gas as a tracer for leak detection and use oil-pumped dry nitrogen to develop the required test pressure. Test the high and low side of the system at pressures dictated by local codes.

1. Close the field supplied liquid line service valve(s) installed near the evaporator and the compressor discharge service valve to isolate the system's high side from the low side. Pressure test the liquid line, discharge line, and condenser coils at pressures dictated by local codes. Do not exceed 10# above the pressure control settings.
2. Connect a refrigerant cylinder to the charging port of the liquid line service valve. Use the refrigerant to raise the high side pressure to 12 to 15 psig.
3. Disconnect the refrigerant cylinder. Connect a dry nitrogen cylinder to the charging port and increase the high side pressure. Do not exceed the condenser maximum working pressure listed on the unit nameplate.
4. Use a leak detector or soap bubbles to check for leaks. Check all piping joints, valves, etc.
5. If a leak is located, use proper procedures to remove the refrigerant/nitrogen mixture, break the connection and remake as a new joint. Retest for leaks after making repairs.
6. Repeat the test procedure for the low side of the system, charging through the suction pressure gauge port or through an access provided on the suction line by the installer. Increase the system pressure to 100 psig.
7. If a leak is located, use proper procedures to remove the refrigerant/nitrogen mixture, break the connection and remake as a new joint. Retest for leaks after making repairs.
8. Open the liquid line service valve and the compressor discharge service valve.



Installation Electrical

Electrical

Note: Local codes may take precedence.

Table 16. CAUK electrical data

Unit Size (Ton)	Rated Voltage ^(a)	Condenser Fan Motor ^(b)		CPT Amps	Unit Characteristics	
		Qty	FLA		MCA ^(c)	MOP ^(d)
20	200/60/3	2	4.1	1	11	15
	230/60/3	2	4.1	1	11	15
	460/60/3	2	1.8	1	6	15
	575/60/3	2	1.4	1	5	15
25	200/60/3	3	4.1	1	15	15
	230/60/3	3	4.1	1	15	15
	460/60/3	3	1.8	1	7	15
	575/60/3	3	1.4	1	6	15
30	200/60/3	3	4.1	1	15	15
	230/60/3	3	4.1	1	15	15
	460/60/3	3	1.8	1	7	15
	575/60/3	3	1.4	1	6	15
40	200/60/3	4	4.1	1	19	20
	230/60/3	4	4.1	1	19	20
	460/60/3	4	1.8	1	9	15
	575/60/3	4	1.4	1	7	15
50	200/60/3	6	4.1	1	27	30
	230/60/3	6	4.1	1	27	30
	460/60/3	6	1.8	1	13	15
	575/60/3	6	1.4	1	10	15
60	200/60/3	6	4.1	1	27	30
	230/60/3	6	4.1	1	27	30
	460/60/3	6	1.8	1	13	15
	575/60/3	6	1.4	1	10	15
80	200/60/3	8	4.1	1	35	35
	230/60/3	8	4.1	1	35	35
	460/60/3	8	1.8	1	16	20
	575/60/3	8	1.4	1	13	15
100	200/60/3	12	4.1	1	52	60
	230/60/3	12	4.1	1	52	60
	460/60/3	12	1.8	1	24	25
	575/60/3	12	1.4	1	19	20



Installation Electrical

Table 16. CAUK electrical data (continued)

Unit Size (Ton)	Rated Voltage ^(a)	Condenser Fan Motor ^(b)		CPT Amps	Unit Characteristics	
		Qty	FLA		MCA ^(c)	MOP ^(d)
120	200/60/3	12	4.1	1	52	60
	230/60/3	12	4.1	1	52	60
	460/60/3	12	1.8	1	24	25
	575/60/3	12	1.4	1	19	20

- (a) Voltage Utilization Range is +/- 10% of Rated voltage (use range): 200/60/3 (180-220), 230/60/3 (207-253), 460/60/3 (414-506), 575/60/3 (518-633).
 (b) Electrical information is for each individual motor.
 (c) Minimum circuit ampacity (MCA) is 125 percent of the FLA of one motor plus the total FLA of the remaining motors and CPT amps.
 (d) Maximum Overcurrent Protection Device permitted by NEC 440-22 is 225 percent of the FLA of one motor plus the total FLA of the remaining motors and CPT amps.

Wiring Requirements

Main Unit Power Wiring

⚠ WARNING

Hazardous Voltage!

Failure to disconnect power before servicing could result in death or serious injury.

Disconnect all electric power, including remote disconnects before servicing. Follow proper lockout/tagout procedures to ensure the power can not be inadvertently energized. Verify that no power is present with a voltmeter.

⚠ WARNING

Proper Field Wiring and Grounding Required!

Failure to follow code could result in death or serious injury.

All field wiring **MUST** be performed by qualified personnel. Improperly installed and grounded field wiring poses **FIRE** and **ELECTROCUTION** hazards. To avoid these hazards, you **MUST** follow requirements for field wiring installation and grounding as described in NEC and your local/state/national electrical codes.

⚠ WARNING

Electrical Shock Hazard!

Failure to follow instructions below could result in death or serious injury.

Properly connect the system's oversized protective earthing (grounding) terminal(s).

NOTICE

Use Copper Conductors Only!

Failure to use copper conductors could result in equipment damage as the equipment was not designed or qualified to accept other types of conductors.

- Inspect all control panel components. Tighten any loose connections.
- Confirm the unit control circuit switch (1S1) is in the "OFF" position.
- Verify that the power supply to the unit complies with the unit nameplate specification.
- See "Unit Dimensions," p. 13 for electrical wire entry details.
- Table 17, p. 40 lists the field connection wire ranges for the unit terminal block and ground lug.
- Connect properly sized and protected power supply wiring to the unit terminal block (1XD1).
- Confirm that phasing to the unit is correct (See "Electrical Phasing," p. 46).
- Confirm the voltage supply is within 10% of the rated voltage on the unit nameplate (See "Voltage Imbalance," p. 45).
- Connect properly sized ground wires from the unit ground terminal to an earth ground.
- Confirm the holes provided in the outer panels for electrical wiring entry are closed after installation is complete.
- Refer to the unit diagrams for wiring details, if necessary.

Table 17. Field connection wire range

Component type/size	Wire Qty per phase	Wire size range
175A Terminal Block	1	14 AWG - 2/0 AWG
Ground lug	1	14 AWG - 2 AWG ^(a)

(a) Ground lug torque = 35 in-lbs for 14-10 AWG, 40 in-lbs for 8 AWG, 45 in-lbs for 6-4 AWG, 50 in-lbs for 3-2/0 AWG

Controls Wiring

⚠ WARNING

Hazardous Voltage!

Failure to disconnect power before servicing could result in death or serious injury.

Disconnect all electric power, including remote disconnects before servicing. Follow proper lockout/tagout procedures to ensure the power can not be inadvertently energized. Verify that no power is present with a voltmeter.

⚠ WARNING

Proper Field Wiring and Grounding Required!

Failure to follow code could result in death or serious injury.

All field wiring **MUST** be performed by qualified personnel. Improperly installed and grounded field wiring poses **FIRE** and **ELECTROCUTION** hazards. To avoid these hazards, you **MUST** follow requirements for field wiring installation and grounding as described in NEC and your local/state/national electrical codes.

NOTICE

Use Copper Conductors Only!

Failure to use copper conductors could result in equipment damage as the equipment was not designed or qualified to accept other types of conductors.

NOTICE

Component Failure!

Resistance in excess of 3 ohms per conductor could result in component failure due to insufficient AC voltage supply.

Do not exceed three (3) ohms per conductor for the length of the run.

- Inspect all control panel components. Tighten any loose connections.
- Confirm the unit control circuit switch (1S1) is in the OFF position.
- See [“Unit Dimensions,” p. 13](#) for electrical wire entry details.
- Connect the Compressor Interlock switches
- Confirm the holes provided in the outer panels for electrical wiring entry are closed after installation is complete.
- Refer to the unit diagrams for wiring details, if necessary.

Table 18. Control wire selections

Wire Gauge	Ohms per 1000 feet	Max Wire Length (ft)
18	8	500
16	5	1000
14	3	2000
12	2	3000

Operating Principles

Component Locations

Condenser Fans

Figure 22. Condenser fan locations: 20 to 60 ton units

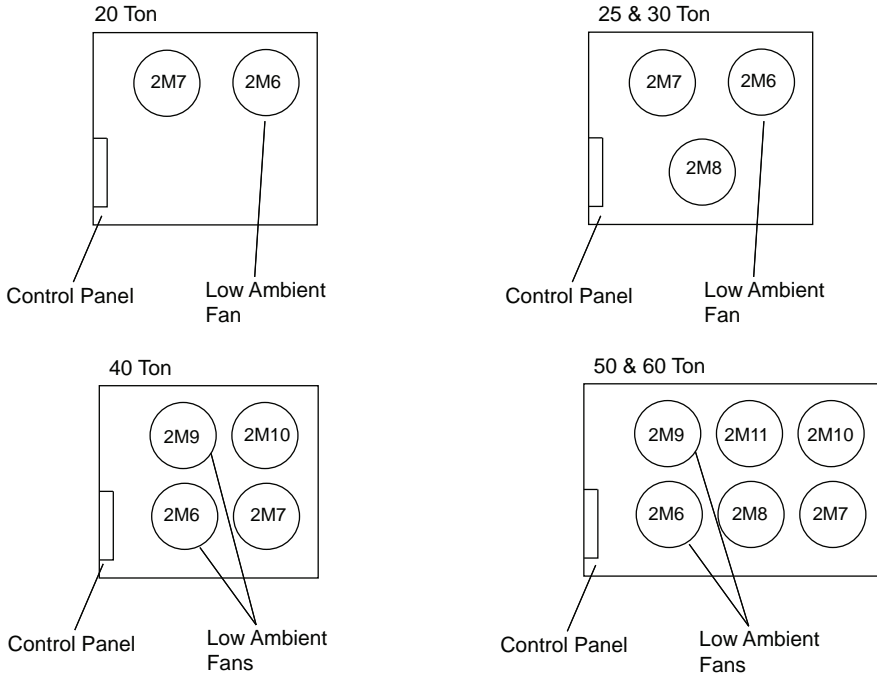
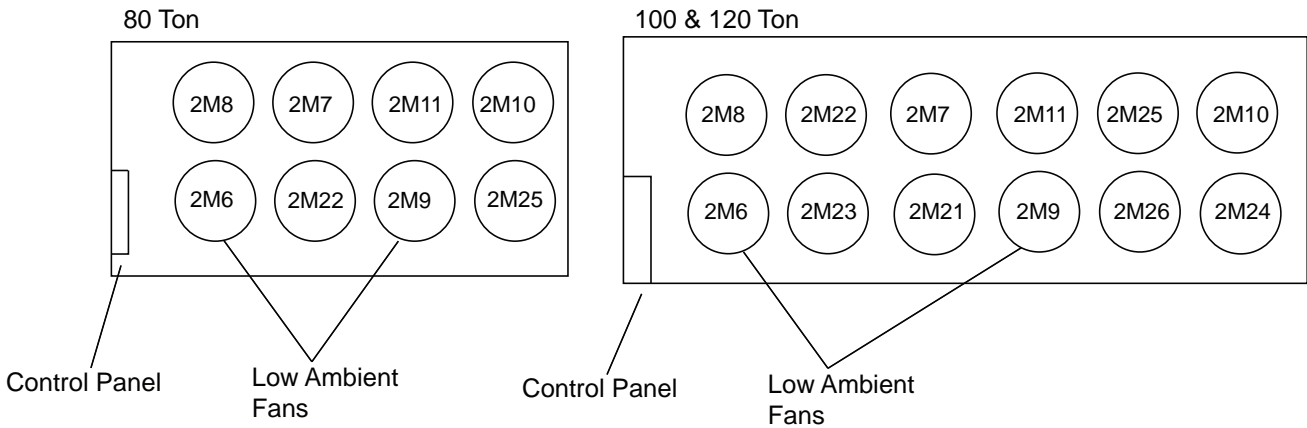

Figure 23. Condenser fan locations: 80 to 120 ton units



Unit Operation

Standard air cooled condensers function as the outdoor condensing units for appropriately sized split refrigeration systems. These units, operating in conjunction with a matched indoor compressor/evaporator configuration, provide refrigerant condensing for these systems down to a normal ambient temperature of 40° F. Operation to 0° F ambient is possible with the addition of head pressure controllers and associated wiring.

All condenser fans are direct drive, 26 inch propeller type. They are driven by 1 HP thermally protected motors.

When wired properly, the unit will start and operate satisfactorily as long as the operating temperature is above the minimum operating temperature shown in .

The condensing unit operation starts and stops automatically when the cooling demand is initiated and terminated by the cooling circuit interlock relays.

Condenser Fans

20 to 60 Ton Condenser Fans

Condenser fan cycling is accomplished through interlocking the fan operation with remote compressor operation and liquid line pressure switches (2S32 and 2S33). When the low ambient option is applied, ambient temperature thermostats (1S30 and 1S31) are used to provide additional fan cycling control. See “[Condenser Fans](#),” p. 42 for condenser fan locations and designations. Refer to the unit wiring diagrams for details, if necessary.

80 to 120 Ton Condenser Fans

Condenser fan cycling is accomplished through interlocking the fan operation with remote compressor operation and ambient temperature thermostats (1S28 and 1S29). See “[Condenser Fans](#),” p. 42 for condenser fan locations and designations. Refer to the unit wiring diagrams for details, if necessary.

Low Ambient Control

Low Ambient control is available as a factory installed option or can be field installed. Head pressure controllers are used to extend the operation of these units from the standard operational temperatures to a minimum of 0°F without hot gas bypass or 10°F with hot gas bypass. These values apply when wind speed across the condenser coil is less than 5 mph. If typical wind speeds are higher than 5 mph, a wind screen around the unit may be required. By restricting the airflow across the condenser coils, saturated condensing temperatures can be maintained as the ambient temperature changes.

Each refrigerant circuit requires one head pressure controller, ambient thermistor, discharge pressure transducer, and associated wiring. Additionally, all low ambient units require a 24V transformer. Each head pressure controller controls power to one condenser fan motor for each refrigerant circuit in response to the outdoor ambient temperature and the discharge line pressure. The pressure setpoint should be adjusted to 230 psig initially. When the ambient temperature is above 50°F, the condenser fan motor will be energized continuously. When the ambient temperature is below 50°F, the pressure sensor measurement is used to switch the condenser fan motor on or off. When the measured pressure is 15 psi below the set pressure the condenser fan motor will be turned off. When the measured pressure is 15 psi above the set pressure, the condenser fan motor will be turned on.

Notes:

- The pressure setting is adjustable from 35-465psig
- The “Heat Pump” jumper should be placed in the N.O. position

Figure 24. Head pressure controller

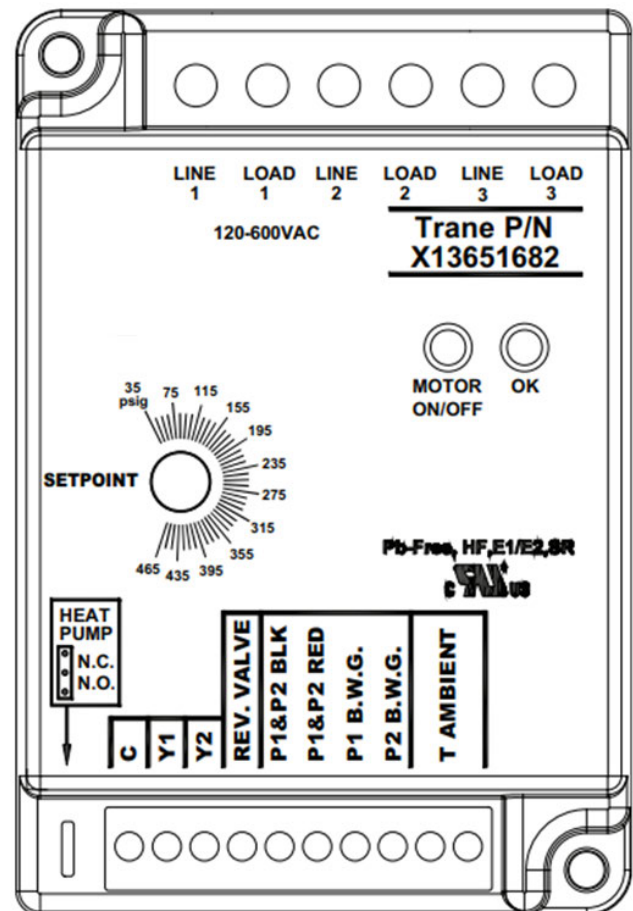



Pre-Start

Use the checklist provided below in conjunction with the “General Unit Requirements,” p. 33 to ensure that the unit is properly installed and ready for operation. Be sure to complete all of the procedures described in this section before starting the unit for the first time.

⚠ WARNING

Hazardous Voltage!

Failure to disconnect power before servicing could result in death or serious injury.

Disconnect all electric power, including remote disconnects before servicing. Follow proper lockout/tagout procedures to ensure the power can not be inadvertently energized. Verify that no power is present with a voltmeter.

- Turn the field supplied disconnect switch, located upstream of the unit, to the “Off” position.
- Check all electrical connections for tightness and “point of termination” accuracy.
- Verify that the condenser airflow will be unobstructed.
- Check the condenser fan blades. Ensure they rotate freely within the fan orifices and are securely fastened to the fan motor shaft.

NOTICE

Compressor Damage!

Excessive liquid accumulation in the suction lines could result in compressor damage.

Do not allow liquid refrigerant to enter the suction line.

- Verify that all compressor service valves, discharge service valves, and liquid line service valves are back seated on each circuit.
Important: After liquid line service valves are fully opened (back seated), close just 1/4 turn to allow for fan pressure control (4S7, 4S8) operation.
- Check the condenser coils. They should be clean and the fins should be straight. Straighten any bent coil fins with an appropriate sized fin comb.
- Inspect the interior of the unit for tools and debris.

System Evacuation Procedures

NOTICE

Operating Under Vacuum!

Failure to follow these instructions will result in compressor failure.

Do not operate or apply power to the compressor while under a vacuum.

Each refrigeration circuit for split system applications must be evacuated before the unit can be started. Use a rotary type vacuum pump capable of pulling a vacuum of 100 microns or less. Verify that the unit disconnect switch and the system control circuit switches are “OFF”.

The oil in the vacuum pump should be changed each time the pump is used with a high quality vacuum pump oil. Before using any oil, check the oil container for discoloration which usually indicates moisture in the oil and/or water droplets. Moisture in the oil adds to what the pump has to remove from the system, making the pump inefficient.

When connecting the vacuum pump to a refrigeration system, it is important to manifold the vacuum pump to both the high and low side of the system (liquid line access valve and suction line access valve). Follow pump manufacturer’s directions for proper methods of using vacuum pump.

The lines used to connect pump to the system should be copper and the largest diameter that can practically be used. Using larger line sizes with minimum flow resistance can significantly reduce evacuation time. Rubber or synthetic hoses are not recommended for system evacuation. They have moisture absorbing characteristics which result in excessive rates of evaporation, causing pressure rise during standing vacuum test. This makes it impossible to determine if system has a leak, excessive residual moisture, or a continual or high rate of pressure increase due to hoses.

An electronic micron vacuum gauge should be installed in the common line ahead of the vacuum pump shutoff valve, as shown in [Figure 25, p. 45](#). Close Valves B and C, and open Valve A.

Start vacuum pump. After several minutes, the gauge reading will indicate the maximum vacuum the pump is capable of pulling. Rotary pumps should produce vacuums of 100 microns or less.

Open Valves B and C. Evacuate the system to a pressure of 300 microns or less. As vacuum is being pulled on the system, it may appear that no further vacuum is being obtained, yet the pressure is high. To facilitate the evacuation process, it is recommended that the vacuum be “Broken”.

To break the vacuum, close valves A, B, and C and connect a refrigerant cylinder to the charging port on the manifold. Purge the air from the hose. Raise the standing vacuum pressure in the system to “zero” (0 psig) gauge pressure. Repeat this process two or three times during evacuation.

Note: It is unlawful to release refrigerant into the atmosphere. When service procedures require working with refrigerants, the service technician must comply with all Federal, State, and local laws.

Standing Vacuum Test

Once 300 microns or less is obtained, close Valve A and leave valves B and C open. This will allow the vacuum gauge to read the actual system pressure. Let the system equalize for approximately 15 minutes. This is referred to as a “standing vacuum test” where, time versus pressure rise. The maximum allowable rise over a 15 minute period is 200 microns. If the pressure rise is greater than 200 microns but levels off to a constant value, excessive moisture is present. If the pressure steadily continues to rise, a leak is indicated. Figure 26, p. 45 illustrates three possible results of the “standing vacuum test”.

If a leak is encountered, repair the system and repeat the evacuation process until the recommended vacuum is obtained. Once the system has been evacuated, break the vacuum with refrigerant, and complete the remaining “Pre-Start Procedures” before starting the unit.

Figure 25. Typical vacuum pump hookup

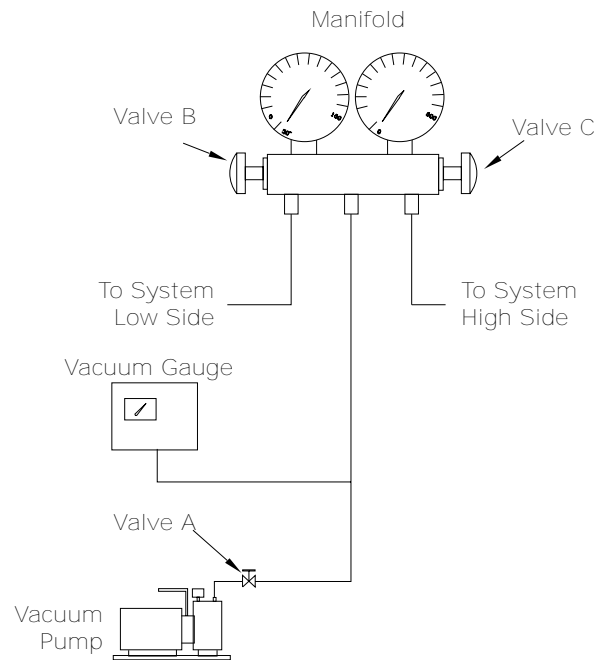
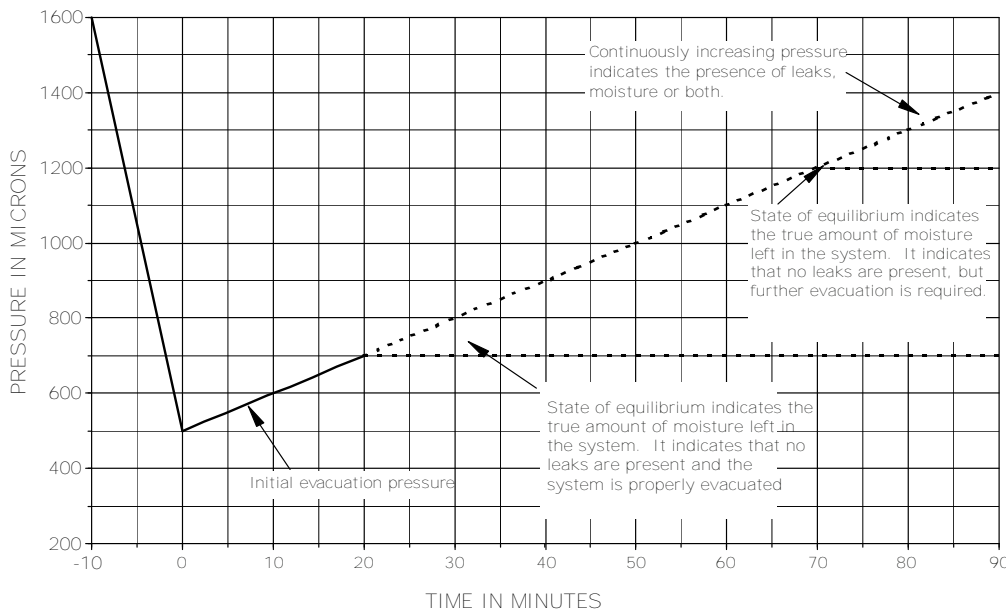

Figure 26. Evacuation time vs. pressure rise



Voltage Imbalance

Excessive three phase voltage imbalance between phases will cause motors to overheat and eventually fail. The maximum allowable voltage imbalance is 2%. Measure and record the voltage between phases 1, 2, and 3 and calculate the amount of imbalance as follows:

% Voltage Imbalance = $100 \times [(AV - VD)/(AV)]$ where:

- AV (Average Voltage) = $(\text{Volt 1} + \text{Volt 2} + \text{Volt 3})/3$
- V1, V2, V3 = Line Voltage Readings

- VD = Line Voltage reading that deviates the farthest from the average voltage.

Example:

If voltage readings of supply power measured 221, 230, and 227, average volts would be:

- $AV = (221 + 230 + 227)/3 = 226 \text{ Avg.}$
- $VD = 221$

The percentage of imbalance is calculated as follows:

- $100 \times [(226 - 221)/226] = 2.2\%$

The 2.2% imbalance in this example exceeds the maximum allowable imbalance of 2.0%. This much imbalance between phases can equal as much as a 20% current imbalance with a resulting increase in motor winding temperatures that will decrease motor life. If the voltage imbalance is over 2%, notify the proper agencies to correct the voltage problem before operating this equipment.

- Restore the main electrical power and recheck the phasing.
- If the phasing is correct, open the main power disconnect switch or circuit protection switch and remove the phase sequence indicator.

Electrical Phasing

⚠ WARNING

Hazardous Voltage!

Failure to disconnect power before servicing could result in death or serious injury.

Disconnect all electric power, including remote disconnects before servicing. Follow proper lockout/tagout procedures to ensure the power can not be inadvertently energized. Verify that no power is present with a voltmeter.

⚠ WARNING

Live Electrical Components!

Failure to follow all electrical safety precautions when exposed to live electrical components could result in death or serious injury.

When it is necessary to work with live electrical components, have a qualified licensed electrician or other individual who has been properly trained in handling live electrical components perform these tasks.

Proper electrical phasing can be quickly determined and corrected before starting unit by using an instrument such as Associated Research Model 45 Phase Sequence Indicator, following steps below

- Turn field supplied disconnect switch that provides power to the condensing unit to "Off" position
- Verify that the 115 volt control switch (1S1) in the unit control box is in the Off position.
- Connect the phase sequence indicator leads to the terminal block or to the "Line" side of the optional factory mounted disconnect switch as follows:
 - Black (phase A) to L1
 - Red (phase B) to L2
 - Yellow (phase C) to L3
- Close the main power disconnect switch or circuit protector switch that provides the supply power to the condensing unit.
- Observe the ABC and CBA phase indicator lights on the face of the sequencer. The ABC indicator light will glow if the phase is ABC. If the CBA indicator light glows, open the disconnect switch or circuit protection switch and reverse any two power wires.



Start-Up

Verifying Proper Condenser Fan Rotation

⚠ WARNING

Rotating Components!

Failure to disconnect power before servicing could result in rotating components cutting and slashing technician which could result in death or serious injury.

Disconnect all electric power, including remote disconnects before servicing. Follow proper lockout/tagout procedures to ensure the power can not be inadvertently energized.

⚠ WARNING

Hazardous Voltage!

Failure to disconnect power before servicing could result in death or serious injury.

Disconnect all electric power, including remote disconnects before servicing. Follow proper lockout/tagout procedures to ensure the power can not be inadvertently energized. Verify that no power is present with a voltmeter.

1. Open the field supplied disconnect switch or circuit protector switch that provides power to the compressor unit and lock it in the OFF position.
2. Open the field supplied disconnect switch or circuit protector switch that provides power to the condensing unit.
3. To install temporary jumpers (refer to unit schematics):
 - a. For 20-60 ton units: install temporary jumpers across pressure switches 2S32 and 2S33
 - b. For 25, 30, 50, and 60 ton units with low ambient option: install temporary jumpers across temperature switches 1S30 and 1S31
 - c. For 80-120 ton units: install temporary jumpers across temperature switches 1S28 and 1S29
4. Close the field supplied disconnect switch or circuit protector switch that provides power to the condensing unit. Turn the control circuit switch (1S1) to the ON position.
5. Close field supplied switches/contacts to apply 115Vac to each of the contactor coils. The fans will start when power is applied.
6. Check the condenser fans for proper rotation. The direction of rotation is clockwise when viewed from the top of the unit.
7. If the condenser fans are rotating in the correct direction, skip to step 9.
8. If the condenser fans are rotating backwards:

- a. Turn the field supplied disconnect switch or circuit protector switch that provides power to the condensing unit to the "OFF" position.
 - b. Interchange any two of the field connected main power wires at the unit terminal block (1XD1) in the unit control panel.
 - c. Repeat steps 4-6 to verify proper rotation.
9. Remove all temporary jumpers previously installed in step 3.

Note: Interchanging "Load" side power wires at the fan contactors will only affect the individual fan rotation. Ensure that the voltage phase sequence at the main terminal block 1XD1 is ABC as outlined in "Electrical Phasing," p. 46.

Charging the System

1. Verify that all discharge service valves and liquid line service valves for each circuit is back seated.
2. Attach a set of service gauges onto the liquid line and discharge line gauge ports for each circuit.
3. Charge liquid refrigerant into the liquid line of each refrigerant circuit with the required amount of R-410A/R-454B refrigerant should be charged into the system by weight.

Use an accurate scale or a charging cylinder to monitor the amount of refrigerant entering the system. See [Table 20, p. 48](#) for the recommended refrigerant capacities for the condensing unit. The weight of refrigerant required for the liquid line and liquid line driers are listed in [Table 21, p. 48](#).

If the pressure within the system equalizes with the pressure in the charging cylinder before charging is completed, complete the process by vapor charging into the suction (low) side of the system after the system has been started.

gives the minimum starting temperatures for both "Standard" and "Low" Ambient units.

Do not attempt to charge the system with the low ambient dampers and/or hot gas bypass operating (if applicable). Disable the low ambient dampers in the "Open" position and de-energize the hot gas bypass solenoid valves before proceeding.

4. On units with dual circuits, start only one circuit at a time. To disable the second circuit compressors, refer to the compressor sequencing information that shipped with the compressor unit.
5. With the compressors operating, slowly open the "Low Side" valve on the manifold gauge set. The remainder of the refrigerant will be drawn into the system.
6. Once the charging for the operating circuit has been completed, check and record the:



Start-Up

- ambient temperature;
- compressor oil level (each circuit); compressor suction and discharge pressures (each circuit);
- superheat and subcooling (each circuit);

Record this data on an "operator's maintenance log" like the one shown in [Table 24, p. 50](#). If the operating pressures indicate a refrigerant shortage, measure the system superheat and system subcooling. Repeat steps 1 through 6 for the second refrigeration circuit, if applicable.

Table 19. Recommended refrigerant capacities R-410A

Unit Size	Operating Charge per Circuit ^(a)	Condenser Storage Capacity ^(b)
C20	12	19
C25	12	19
C30	12	19
C40	11	24
C50	12	25
C60	13	32
C80	29	47
D10	30	50
D12	33	63

^(a) CAUJ-C20 through C30 are single circuit units. CAUJ C40 through D12 are dual circuit units.

^(b) Pounds R-410A per circuit at 95°F ambient, 95% full.

Table 20. Recommended refrigerant capacities R-454B

Liquid Line O.D.	Liquid Line Charge	Sporlan Part No	Drier Refrigerant Charge
5/8"	1.827	C-305-S	1 lb. - 1 oz.
3/4"	2.728	C-307-S	1 lb. - 1 oz.
		C-417-S	1 lb. - 8 oz.
7/8"	3.790	C-307-S	1 lb. - 1 oz.
		C-417-S	1 lb. - 8 oz.
1-1/8"	6.461	C-419-S	1 lb. - 8 oz.

Note: Refrigerant charge given in ounces per foot.

Table 21. Liquid line and drier refrigerant requirements

Liquid Line O.D.	Liquid Line Charge	Sporlan Part No	Drier Refrigerant Charge
5/8"	1.827	C-305-S	1 lb. - 1 oz.
3/4"	2.728	C-307-S	1 lb. - 1 oz.
		C-417-S	1 lb. - 8 oz.
7/8"	3.790	C-307-S	1 lb. - 1 oz.
		C-417-S	1 lb. - 8 oz.
1-1/8"	6.461	C-419-S	1 lb. - 8 oz.

Note: Refrigerant charge given in ounces per foot.

Table 22. Minimum starting ambient temperatures R-410A

Unit Size (tons)	Standard Units		Low Ambient Units	
	With HGBP	No HGBP	With HGBP (2)	No HGBP (2)
20-60	40	30	10	0
80-120	—	10	0	0

Note: Minimum starting ambients in degrees F, based on unit at minimum step of unloading and 5 mph wind across condenser.

Table 23. Minimum starting ambient temperatures R-454B

Unit Size (tons)	Standard Units		Low Ambient Units	
	With HGBP	No HGBP	With HGBP	No HGBP
20 to 120	50	40	10	0

Note: Minimum starting ambients in degrees F, based on unit at minimum step of unloading and 5 mph wind across condenser.

Table 24. Sample maintenance log

Date	Current Ambient Temp. (°F)	Refrigerant Circuit #1						Refrigerant Circuit #2					
		Compr. Oil level	Suct. Press. (Psig)	Disch. Press. (Psig)	Liquid Press. (Psig)	Superheat (°F)	Subcool (°F)	Compr. Oil level	Suct. Press. (Psig)	Disch. Press. (Psig)	Liquid Press. (Psig)	Superheat (°F)	Subcool (°F)
		- ok- Low						- ok- Low					
		- ok- Low						- ok- Low					
		- ok- Low						- ok- Low					
		- ok- Low						- ok- Low					
		- ok- Low						- ok- Low					
		- ok- Low						- ok- Low					
		- ok- Low						- ok- Low					
		- ok- Low						- ok- Low					

Note: Check and record the data requested above each month during the cooling season with the unit running



Maintenance

Monthly Maintenance

Air Handling Equipment

⚠ WARNING

Hazardous Voltage!

Failure to disconnect power before servicing could result in death or serious injury.

Disconnect all electric power, including remote disconnects before servicing. Follow proper lockout/tagout procedures to ensure the power can not be inadvertently energized. Verify that no power is present with a voltmeter.

Before completing the following checks, turn the system control circuit switch 1S1 to the "Off" position. Open the main power disconnect switch for the Condensing Unit and Air Handling Unit and "lock it" in the "Off" position before removing any access panels.

- Inspect the return air filters. Clean or replace them if necessary.
- Check the evaporator drain pan and condensate piping to ensure that there are no blockages.
- Inspect the evaporator coils for dirt. If the coils appear dirty, clean them according to the instructions described in "Coil Cleaning," p. 51.
- Inspect the economizer damper hinges and pins (if applicable) to ensure that all moving parts are securely mounted. Clean the blades as necessary.
- Verify that all damper linkages move freely. Lubricate with white grease, if necessary.
- Check Supply Fan motor bearings. Repair or replace the motor as necessary.
- Check the fan shaft bearings for wear. Replace the bearings as necessary.
- Lubricate supply fan bearings. Contact equipment manufacturer for recommended greases.

NOTICE

Bearing Damage!

Over lubrication could result in as much damage to fan bearings as not enough grease.

To prevent damage to fan bearings, do not over lubricate.

Important: Use a hand grease gun to lubricate bearings. Add grease until a light bead appears all around the seal.

After greasing the bearings, check the setscrews to ensure that the shaft is held securely to the bearings and fan wheels. Make sure that all bearing supports are tight.

- Check the supply fan belt(s). If the belts are frayed or worn, replace them.
- Verify that all wire terminal connections are tight.
- Inspect unit for unusual conditions (e.g., loose access panels, leaking piping connections, etc.)
- When checks are complete, verify all retaining screws are reinstalled in unit access panels.

Condensing Unit

⚠ WARNING

Rotating Components!

Failure to disconnect power before servicing could result in rotating components cutting and slashing technician which could result in death or serious injury.

Disconnect all electric power, including remote disconnects before servicing. Follow proper lockout/tagout procedures to ensure the power can not be inadvertently energized.

- Manually rotate the condenser fans to ensure free movement and check motor bearings for wear. Verify that all of the fan mounting hardware is tight.
- Verify that all wire terminal connections are tight.
- Inspect the condenser coils for dirt and foreign debris. If the coils appear dirty, clean them according to the instructions described in "Coil Cleaning," p. 51.
- Inspect the compressor and condenser fan motor contactors. If the contacts appear severely burned or pitted, replace the contactor. Do not clean the contacts.
- Check the compressor oil level. (Compressors "Off")

Coil Cleaning

NOTICE

Damaging Coil Cleaners!

Coil cleaners can damage roofs, surrounding buildings, vehicles, etc.

Cleaning substances should be checked to ensure that they will not cause damage to surroundings.

Coils and roof (if applicable) should be rinsed thoroughly. Do not spray coil cleaners in windy conditions.

Regular coil maintenance, including annual cleaning, enhances unit's operating efficiency by minimizing:

- compressor head pressure and amperage draw;
- water carryover;
- fan brake horsepower; and,
- static pressure losses.

At least once each year – or more often if the unit is located in a "dirty" environment – clean the microchannel

condenser using the instructions outlined below. Be sure to follow these instructions as closely as possible to avoid damaging the coils.

To clean refrigerant coils, use a soft brush and a sprayer.

Note: *DO NOT use any detergents with microchannel condenser coils. Pressurized water or air ONLY.*

1. Remove enough panels from the unit to gain safe access to coils.

⚠ WARNING

No Step Surface!

Failure to follow instruction below could result in death or serious injury.

Do not walk on the sheet metal drain pan. Walking on the drain pan could cause the supporting metal to collapse and result in the operator/technician falling.

Important: *Bridging between the main supports required before attempting to enter into the unit. Bridging may consist of multiple 2 by 12 boards or sheet metal grating.*

2. Straighten any bent coil fins with a fin comb.
3. For accessible areas, remove loose dirt and debris from both sides of the coil. For dual row microchannel condenser coil applications, seek pressure coil wand extension through the local Trane Parts Center.

Note: *DO NOT use any detergents with microchannel coils. Pressurized water or air ONLY.*
4. Pour the cleaning solution into the sprayer. If a high-pressure sprayer is used:
 - a. The minimum nozzle spray angle is 15 degrees.
 - b. Do not allow sprayer pressure to exceed 600 psi.
 - c. Spray the solution perpendicular (at 90 degrees) to the coil face.
5. Spray the leaving-airflow side of the coil first; then spray the opposite side of the coil. For evaporator and reheat coils, allow the cleaning solution to stand on the coil for five minutes.
6. Rinse both sides of the coil with cool, clean water.
7. Inspect both sides of the coil; if it still appears to be dirty, repeat [Step 6](#) and [Step 7](#).

8. Reinstall all of the components and panels removed in [Step 1](#); then restore power to the unit.

Microchannel Condenser Coil Repair and Replacement

If microchannel condenser coil repair or replacement is required, see *Unitary Light and Large Commercial Units General Service Bulletin* (RT-SVB83*-EN) for further details.

Fall Restraint — Condenser Roof

⚠ WARNING

Falling Off Equipment!

Failure to follow instructions below could result in death or serious injury.

This unit is built with fall restraint slots located on unit top that MUST be used during servicing. These slots are to be used with fall restraint equipment that will not allow an individual to reach the unit edge. However such equipment will NOT prevent falling to the ground, as they are NOT designed to withstand the force of a falling individual.

This unit is built with fall restraint slots located on unit top that must be used during servicing. See following figures.

Figure 27. Fall restraint slot

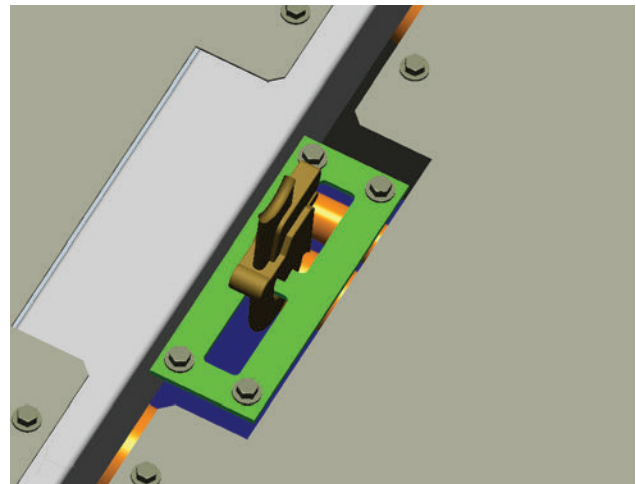
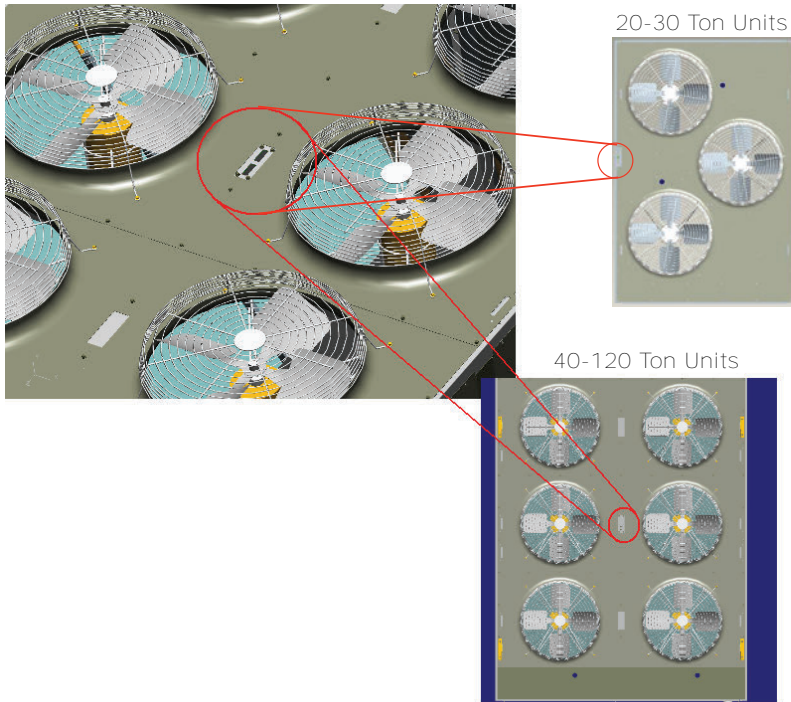

Figure 28. Fall restraint slot location





Warranty and Liability Clause

Commercial Equipment Rated 20 Tons and Larger and Related Accessories

*Optional Extended Warranties are available for compressors and heat exchangers of Combination Gas-Electric Air Conditioning Units.

Products Covered

This warranty* is extended by Trane Inc. and applies only to commercial equipment rated 20 Tons and larger and related accessories.

The Company warrants for a period of 12 months from initial start-up or 18 months from date of shipment, whichever is less, that the Company products covered by this order (1) are free from defects in material and workmanship and (2) have the capacities and ratings set forth in the Company's catalogs and bulletins, provided that no warranty is made against corrosion, erosion or deterioration. The Company's obligations and liabilities under this warranty are limited to furnishing f.o.b. factory or warehouse at Company designated shipping point, freight allowed to Buyer's city (or port of export for shipment outside the conterminous United States) replacement equipment (or at the option of the Company parts therefore) for all Company products not conforming to this warranty and which have been returned to the manufacturer. The Company shall not be obligated to pay for the cost of lost refrigerant. No liability whatever shall attach to the Company until said products have been paid for and then said liability shall be limited to the purchase price of the equipment shown to be defective.

The Company makes certain further warranty protection available on an optional extra-cost basis. Any further warranty must be in writing, signed by an officer of the Company.

The warranty and liability set forth herein are in lieu of all other warranties and liabilities, whether in contract or in negligence, express or implied, in law or in fact, including implied warranties of merchantability and fitness for particular use. In no event shall the Company be liable for any incidental or consequential damages.

THE WARRANTY AND LIABILITY SET FORTH HEREIN ARE IN LIEU OF ALL OTHER WARRANTIES AND LIABILITIES, WHETHER IN CONTRACT OR IN NEGLIGENCE, EXPRESS OR IMPLIED, IN LAW OR IN FACT, INCLUDING IMPLIED WARRANTIES OF MERCHANTABILITY AND FITNESS FOR PARTICULAR USE, IN NO EVENT SHALL WARRANTOR BE LIABLE FOR ANY INCIDENTAL OR CONSEQUENTIAL DAMAGES.

Manager - Product Service

Trane Inc.

Clarksville, Tn 37040-1008

PW-215-2688



Wiring Diagrams

Note: Published unit wiring diagrams (individual, separate diagrams for unitary product lines) are available via e-Library.

Drawing Number	Description
121348760001	SCHEMATIC; SHEET 1, POWER, CA, 80-120T
121348770001	SCHEMATIC; SHEET 1, POWER, CA, 20-60T
121348780001	SCHEMATIC; SHEET 2, CONTROLS, CA, 80-120T
121348790001	SCHEMATIC; SHEET 2, CONTROLS, CA, 20-60T
121348800001	SCHEMATIC; SHEET 3, CONTROLS, CA, LOW AMBIENT
121348810001	DIAGRAM; SHEET 4, COMPONENT LOCATION, CA, 80-120T
2307-9123	Power Schematic Diagram — Air-Cooled Condensing Unit - Line Voltage 200–230–460–575/60HZ/3PH — CA 20–60 Ton
2307-9124	Unit and Field Connection Wiring Diagram — Air-Cooled Condensing Unit — Line Voltage 200, 230, 460, 575/60HZ/3PH — CA 20–60 Ton
2307-9125	Power Schematic Diagram — Split System Condensing Unit — Duplex Condensing Units — CA 80–120 Ton
2307-9126	Unit and Field Connection Wiring Diagram — Air-Cooled Condensing Unit — Duplex Condensing Unit — CA 80–120 Ton

Trane - by Trane Technologies (NYSE: TT), a global innovator - creates comfortable, energy efficient indoor environments for commercial and residential applications. For more information, please visit trane.com or tranetechnologies.com.

Trane has a policy of continuous product and product data improvements and reserves the right to change design and specifications without notice. We are committed to using environmentally conscious print practices.

CAUK-SVX001C-EN 17 Jul 2026
Supersedes CAUK-SVX001B-EN (May 2025)

©2026 Trane