



Installation, Operation, and Maintenance Tracer XM30, XM32, XM70, and XM90 Expansion Modules



⚠ SAFETY WARNING

Only qualified personnel should install and service the equipment. The installation, starting up, and servicing of heating, ventilating, and air-conditioning equipment can be hazardous and requires specific knowledge and training. Improperly installed, adjusted or altered equipment by an unqualified person could result in death or serious injury. When working on the equipment, observe all precautions in the literature and on the tags, stickers, and labels that are attached to the equipment.



Introduction

This guide provides installation, operation, and maintenance information for the following:

- Tracer® XM30 Expansion Module (Orderable part number: X13651537010)
- Tracer® XM32 Expansion Module (Orderable part number: X13651563010)
- Tracer® XM70 Expansion Module (Orderable part number: X13651568010)
- Tracer® XM90 Expansion Module (Orderable part number: X13651701002)

Expansion modules provide additional hardware terminations when needed for Tracer SC+, Tracer UC400/UC600 and Symbio 210/210e/400B/500/800 applications. Each of the expansion modules listed above vary in the type and capability of expansion. In some cases, additional Tracer PM014 DC power supply modules are required.

Warnings, Cautions, and Notices

Safety advisories appear throughout this manual as required. Your personal safety and the proper operation of this machine depend upon the strict observance of these precautions.

The three types of advisories are defined as follows:



Indicates a potentially hazardous situation which, if not avoided, could result in death or serious injury.



Indicates a potentially hazardous situation which, if not avoided, could result in minor or moderate injury. It could also be used to alert against unsafe practices.

NOTICE

Indicates a situation that could result in equipment or property-damage only accidents.

⚠ WARNING

Proper Field Wiring and Grounding Required!

Failure to follow code could result in death or serious injury.

All field wiring **MUST** be performed by qualified personnel. Improperly installed and grounded field wiring poses **FIRE** and **ELECTROCUTION** hazards. To avoid these hazards, you **MUST** follow requirements for field wiring installation and grounding as described in NEC and your local/state/national electrical codes.

⚠ WARNING

Personal Protective Equipment (PPE) Required!

Failure to wear proper PPE for the job being undertaken could result in death or serious injury.

Technicians, in order to protect themselves from potential electrical, mechanical, and chemical hazards, **MUST** follow precautions in this manual and on the tags, stickers, and labels, as well as the instructions below:

- Before installing/servicing this unit, technicians **MUST** put on all PPE required for the work being undertaken (Examples; cut resistant gloves/sleeves, butyl gloves, safety glasses, hard hat/bump cap, fall protection, electrical PPE and arc flash clothing). **ALWAYS** refer to appropriate Safety Data Sheets (SDS) and OSHA guidelines for proper PPE.
- When working with or around hazardous chemicals, **ALWAYS** refer to the appropriate SDS and OSHA/GHS (Global Harmonized System of Classification and Labelling of Chemicals) guidelines for information on allowable personal exposure levels, proper respiratory protection and handling instructions.
- If there is a risk of energized electrical contact, arc, or flash, technicians **MUST** put on all PPE in accordance with OSHA, NFPA 70E, or other country-specific requirements for arc flash protection, **PRIOR** to servicing the unit. **NEVER PERFORM ANY SWITCHING, DISCONNECTING, OR VOLTAGE TESTING WITHOUT PROPER ELECTRICAL PPE AND ARC FLASH CLOTHING. ENSURE ELECTRICAL METERS AND EQUIPMENT ARE PROPERLY RATED FOR INTENDED VOLTAGE.**

⚠ WARNING**Follow EHS Policies!**

Failure to follow instructions below could result in death or serious injury.

- All Trane personnel must follow the company's Environmental, Health and Safety (EHS) policies when performing work such as hot work, electrical, fall protection, lockout/tagout, refrigerant handling, etc. Where local regulations are more stringent than these policies, those regulations supersede these policies.
- Non-Trane personnel should always follow local regulations.

Copyright

This document and the information in it are the property of Trane, and may not be used or reproduced in whole or in part without written permission. Trane reserves the right to revise this publication at any time, and to make changes to its content without obligation to notify any person of such revision or change.

Trademarks

All trademarks referenced in this document are the trademarks of their respective owners.

Revision History

- Updated Tracer UC400 and Tracer UC600 to Tracer SC+, Tracer UC400/UC600 and Symbio 210/210e/400B/500/800 throughout the document.
- Updated Storage and operating environment specifications table in the Overview chapter.
- Updated Installing the Tracer Expansion Modules chapter.



Table of Contents

Overview	5
Specifications	5
Configurable Connections	5
Required Tools for Mounting and Wiring	8
Dimensions	8
Power Budget	11
Calculating DC Power Consumption	11
Symbio™ 500 and Tracer UC400 Power Budget	11
Tracer UC600 Power Budget	11
Expansion Module Power Requirements	11
XM70/XM90 Module Power Requirements	11
XM30 and XM32 Module Power Requirements	12
Installing the Tracer Expansion Modules	13
Mounting and Removing Tracer Devices	13
Setting Rotary Switch Addresses	14
IMC Communication and Power Wiring	14
IMC Harness Pins	15
Communication Wiring Examples	15
Remote Mounting	18
AC Power Warnings and Notices	20
Terminal Wiring Requirements	21
Transformer Requirements	21
Wiring AC Power to the XM70/90	21
Configuring the Expansion Modules	22
Expansion Module Operation	24
Troubleshooting	24
Communication	24
Status Errors	24
Commissioning and Troubleshooting in a Powered State	26
Resistive Inputs	26
Voltage Inputs	27
Current Inputs	27
Method 1	27
Method 2	28
Binary Inputs: 24 Vac Detect (Methods 1 or 2)	28
Binary Inputs: Based on Analog Output Connection	29
Voltage Analog Output	29
Current Analog Output (Methods 1 or 2)	30



Overview

This guide provides installation, operation, and maintenance information for Tracer XM30, XM32, XM70, and XM90 expansion modules.

Expansion modules provide additional hardware terminations when needed for Tracer SC+, Tracer UC400/UC600 and Symbio 210/210e/400B/500/800 applications. Commissioning and troubleshooting is covered in a later section.

Specifications

The following table provides storage and operation specifications for the expansion modules.

Table 1. Storage and operating environment specifications

Storage	
Temperature:	-67°F to 185°F (-55°C to 85°C)
Relative humidity:	5% to 95% (non-condensing)
Operating	
Temperature:	-40°F to 158°F (-40°C to 70°C)
Humidity:	5% to 95% (non-condensing)
Power:	<p>XM30 Input: 24 Vdc \pm10%, 120 mA XM32 Input: 24 Vdc \pm10%, 100 mA XM70 Input: 20.4–27.6 Vac (24 Vac, \pm15% nominal) 50 or 60 Hz, 26 VA, (26 VA plus a maximum of 12 VA for each binary output) Output: 24 Vdc \pm10%, device max load 600 mA XM90 Input: 18–30 Vac (24 Vac nominal) 50 or 60 Hz, 50 VA, 2.08A max @ 500mA load (on 24 Vdc output terminals), plus a maximum of 12 VA for each binary output up to 8 total Output: 24 Vdc \pm10%, device max load 500 mA dc Class 2</p>
Communication:	IMC, 5 Vdc, Class 2, IMC terminals
Mounting weight of controller:	<p>XM30 Mounting surface must support .27 lb. (0.122 kg) with terminal connectors: must support .31 lb. (0.142 kg) XM32 Mounting surface must support .43 lb. (0.195 kg) with terminal connectors: must support .47 lb. (0.213 kg) XM70/XM90 Mounting surface must support 1.3 lb. (0.6 kg) with terminal connectors: must support 1.53 lb. (0.69 kg)</p>
Environmental rating (enclosure):	NEMA 1
Installation:	UL 840:Category 3
Pollution:	UL 840:Degree 2
Agency Compliance	
<ul style="list-style-type: none"> UL916 PAZX- Open Energy Management Equipment UL864/UUKL Smoke Control (when installed and programmed in accordance with the <i>Engineered Smoke Control System - Application Guide</i> (BAS-APG040*-EN)) UL94-5V Flammability CE Marked FCC Part 15, Subpart B, Class B Limit 	

Configurable Connections

The following tables provide input and output connection information.



Overview

Table 2. XM30 device connections

Connection	Quantity	Types	Range
Inputs	4 total Can be configured using any combination of analog or binary inputs/analog outputs	Thermistor	2252Ω, 10k, 20k, 100kΩ
		Resistive (Setpoint)	100Ω to 1 MΩ
		RTD	1 kΩ; platinum, Balco™ or nickel
		Current	0 to 20 mA (linear)
		Voltage	0 to 10 Vdc (linear)
		Binary	Dry Contact
		Pulse Accumulator	Minimum 20 milliseconds open or closed
Outputs		Current	0 to 20 mA @ 16V
		Voltage	0 to 16 Vdc @ 20mA

Table 3. XM32 device connections

Connection	Quantity	Types	Range	Notes
Binary output (BO1 to BO4)	4	General purpose	10 A; up to 277 Vac	Power must be wired to the binary output. All outputs are isolated from each other, and from ground or power. Ranges given are per contact
		Motor	1/3 hp@125 Vac or 1/2 hp@277	
		Pilot duty (inductive load)	2 A; up to 125 Vac	
		Resistive load	8 A; up to 250 Vac or 10 A; up to 30 Vac or 10 A; up to 30 Vdc	

Table 4. XM70 device connections

Input/Output type	Quantity	Types	Range	Notes
Universal input	8	Thermistor	10kΩ – Type II, 10kΩ – Type III, 2252Ω – Type II, 20kΩ to – Type IV, 100 kΩ	The XM70 is limited to 10 combined 0 to 20 mA current inputs/outputs when powering up to two expansion modules (XM30/32).
		Resistive (Setpoint)	100Ω to 1MΩ	
		RTD	1kW; 385, 375 platinum, Balco™ or 672 nickel	
		Current	0 to 20 mA (linear)	
		Voltage	0 to 20 Vdc (linear)	
		Binary	Dry contact	
		Pulse Accumulator	Minimum 20 ms, opened or closed	Universal inputs require the following to meet the 25Hz requirement: duty cycle between 30% to 70% relay output - no load present when open.
Universal Input/ Analog Output	Configure using any combination of analog or binary inputs/analog outputs			The XM70 is limited to 10 combined 0 to 20 mA current inputs/outputs when powering up to two expansion modules (XM30/32). Universal inputs require the following to meet the 25Hz requirement: duty cycle between 30% to 70% relay output - no load present when open.
Inputs	6	Thermistor	10kΩ – Type II, 10kΩ –Type III, 2252Ω – Type II, 20kΩ – Type IV, 100 kΩ	
		Resistive (Setpoint)	100Ω to 1MΩ	
		RTD	1kΩ; 385, 375 platinum, Balco™ or 672 nickel	
		Current	0 to 20 mA (linear)	
		Voltage	0 to 20 Vdc (linear)	
		Binary	Dry contact	
Outputs		Pulse Accumulator	Minimum 20 ms, opened or closed	
		Current	0 to 20 mA @16 V	—
		Voltage	0 to 10 Vdc @20 mA	Limited to 0-10 Vdc by software. The XM70 is limited to 10 combined 0-20 mA current inputs/outputs when powering up to two expansion modules (XM30/32).
		Pulse	12.5ms to 1 second (12.5ms resolution), 1 second to 60 seconds (0.5 second resolution)	Limited to 0 to 10 Vdc by software.
Binary output	4	Relay – SPST (form A) Wet contact	24 Vac, 0.5A maximum	Ranges are given per contact.
Pressure input	1	3-wire	0 to 5 inH ₂ O	Pressure input supplied with 5 Vdc. Designed for Kavlico™ pressure transducers.
Total terminations	19	—		



Overview

Table 5. XM90 device connections

Input/Output type	Quantity	Types	Range	Notes	
Universal input	16	Thermistor	10kΩ – Type II, 10kΩ –Type III, 2252Ω – Type II, 20kΩ – Type IV, 100 kΩ	The XM90 is limited to 10 combined 0 to 20 mA current inputs/outputs when powering up to two expansion modules (XM30/32).	
		Resistive (Setpoint)	100Ω to 1MΩ		
		RTD	1kΩ; 385, 375 platinum, Balco™ or 672 nickel		
		Current	0 to 20 mA (linear)		
		Voltage	0 to 20 Vdc (linear)		
		Binary	Dry contact		
		Pulse Accumulator	Minimum 20 ms, opened or closed	Universal inputs require the following to meet the 25Hz requirement: duty cycle between 30% to 70% relay output - no load present when open.	
Universal Input/ Analog Output	Configure using any combination of analog or binary inputs/analog outputs			The XM90 is limited to 10 combined 0 to 20 mA current inputs/outputs when powering up to two expansion modules (XM30/32). Universal inputs require the following to meet the 25Hz requirement: duty cycle between 30% to 70% relay output - no load present when open.	
Inputs	8	Thermistor	10kΩ – Type II, 10kΩ –Type III, 2252Ω – Type II, 20kΩ – Type IV, 100 kΩ		
		Resistive (Setpoint)	100Ω to 1MΩ		
		RTD	1kΩ; 385, 375 platinum, Balco™ or 672 nickel		
		Current	0 to 20 mA (linear)		
		Voltage	0 to 20 Vdc (linear)		
		Binary	Dry contact		
Outputs		Pulse Accumulator	Minimum 20 ms, opened or closed		
		Current	0 to 20 mA @16 Vdc, Class 2		AO1/UI17 to AO8/UI24
		Voltage	0 to 10 Vdc @20 mA, Class 2 80 Hz < 15V, Class 2		Limited to 0 to 10 Vdc by software. The XM90 is limited to 10 combined 0 to 20 mA current inputs/outputs when powering up to two expansion modules (XM30/32). AO1/UI17 to AO8/UI24.
		Pulse	12.5ms to 1 second (12.5ms resolution), 1 second to 60 seconds (0.5 second resolution)	Limited to 0 to 10 Vdc by software. AO1/UI17 to AO8/UI24.	
Binary output	8	Relay – SPST (form A) Wet contact	24 Vac, 0.5A maximum each, Class 2	Ranges are given per contact. BO1 to BO8.	
Total terminations	32	—	—	—	

Required Tools for Mounting and Wiring

A 1/8 in. (3 mm), flat-bladed screwdriver is required to perform functions such as setting rotary addressing switches, tightening or loosening screw terminals, and removing or repositioning the controller on DIN rail.

Dimensions

The following figures illustrate dimensions for the expansion modules. DIN width measurements help determine how many modules can be installed on a DIN rail; use the following standard:

DIN Standard 43 880 standard profile, Built-in Equipment for Electrical Installations, Overall Dimensions and Related Mounting Dimensions.

*One DIN unit = 18 mm.

Figure 1. XM30 dimensions

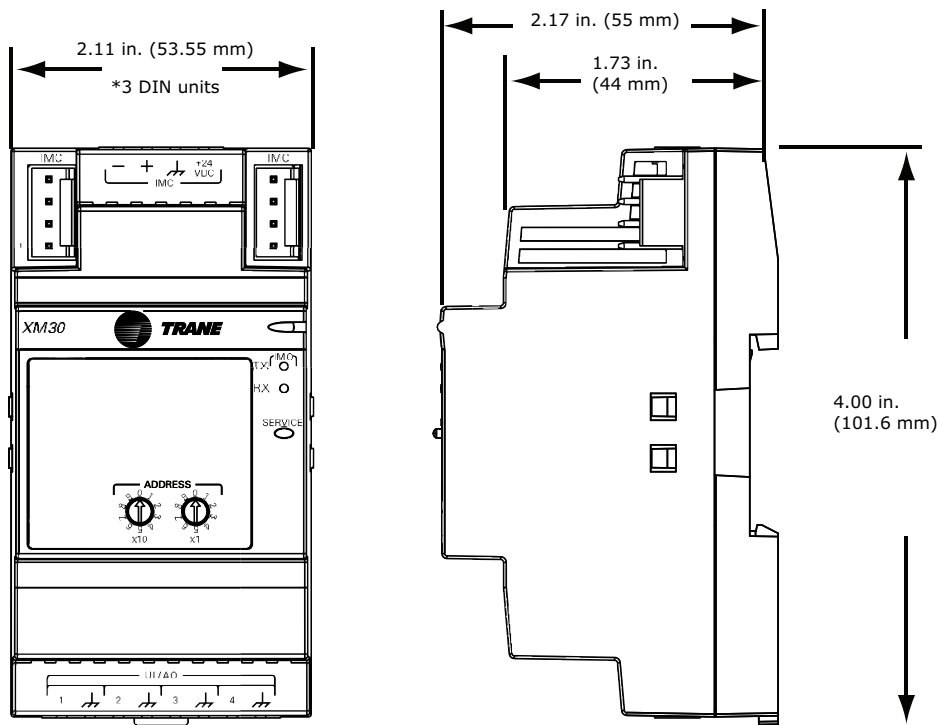

Figure 2. XM32 dimensions

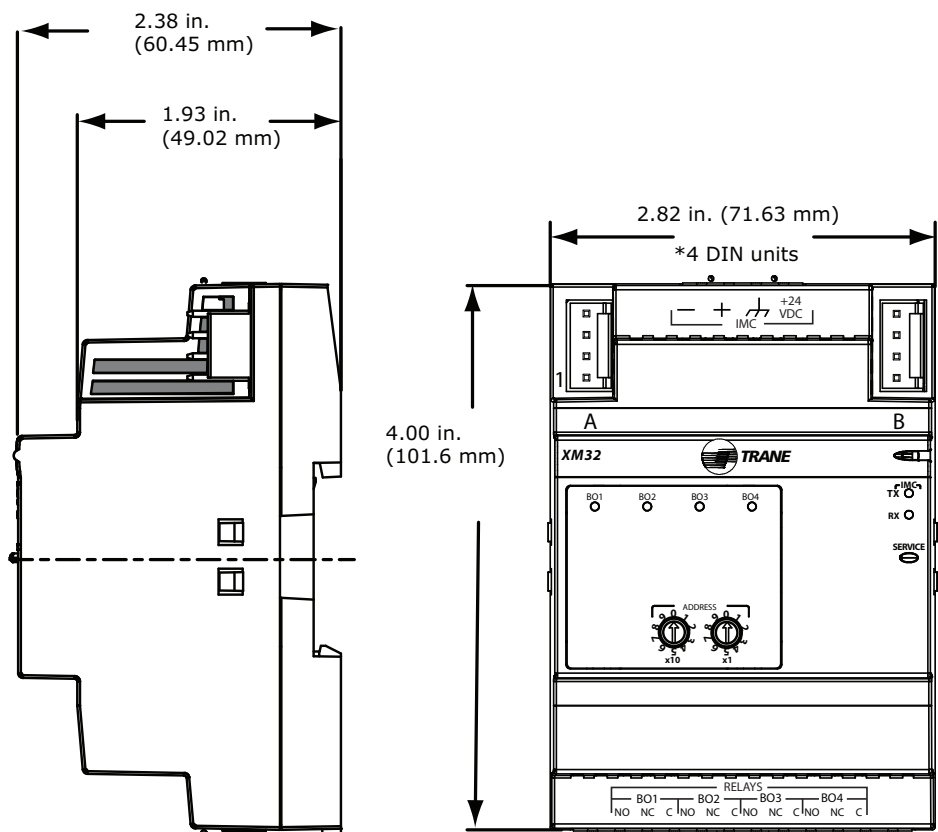
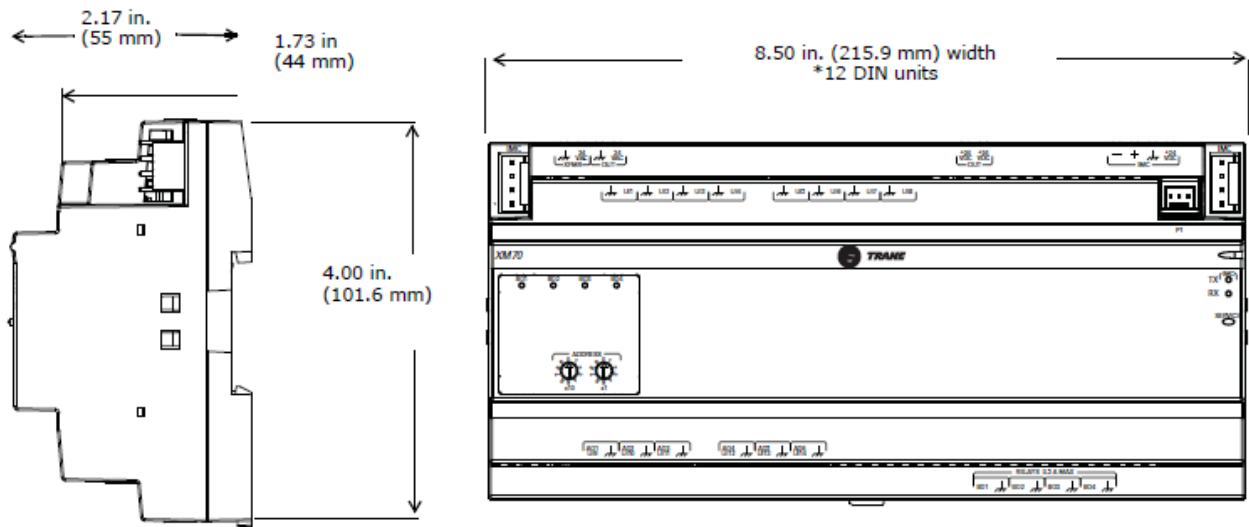

Figure 3. XM70/XM90 dimensions



Power Budget

This section provides information about power budget consumption for the UC400, UC600, and XM70/XM90 when using XM30 and XM32 expansions modules.

Calculating DC Power Consumption

Symbio™ 500 and Tracer UC400 Power Budget

Symbio 500 and Tracer UC400 are capable of providing up to 200 mA of DC power dedicated to the IMC link. Considering the following when budgeting DC power:

- In most applications the Symbio 500 and Tracer UC 400 can support a maximum of two expansion modules without any issues, provided that all terminations are NOT configured for 0 to 20mA.
- Symbio 500 and Tracer UC 400 can support a maximum of two XM30 modules with seven terminations configured for 0 to 20mA, running continuously at 20 mA.
 - If all 0 to 20 mA terminations are expected to run continuously at 20mA, a PM014 power supply module should be used instead of the IMC link to power both modules.

Note: For more details, see *Symbio™ 500 Programmable Controller - Installation, Operation, and Maintenance (BAS-SVX090*-EN)* and *Tracer® UC400 Programmable Controller - Installation, Operation, and Maintenance (BAS-SVX20*-EN)*.

Tracer UC600 Power Budget

The Tracer UC600 controller is capable of providing 600 mA of power. Observe the following rules when budgeting for DC power:

- The UC600/XM70/XM90 can power a maximum of two small expansion modules.
- Each UC600/XM70/XM90 can power up to 10 points configured as 4 to 20 mA In/Out (loop powered).
- Include any additional devices where Tracer UC600 is providing 24 Vdc.

Use the following table to help determine your UC600/XM70/XM90 DC power supply needs.

Table 6. Tracer UC600/XM70/XM90 DC power budget worksheet

Component	No. of terminations	mA power draw	Total mA
Base electronics plus binary outputs	1	x 146	146
0 to 20 mA Universal inputs/outputs	—	x 20	—
XM30 expansion module	—	x 120	—
XM32 expansion module	—	x 100	—
Additional DC powered devices	—	—	—
Total DC power draw must be less than 600 mA for UC600/XM70, less than 800 mA for the XM90			Total

Expansion Module Power Requirements

XM70/XM90 Module Power Requirements

To ensure proper operation of the XM70/XM90, install the power supply circuit in accordance with the following guidelines:

- The XM70/XM90 must receive AC power from a dedicated power circuit; failure to comply may cause the controller to malfunction.
- A dedicated power circuit disconnect-switch must be near the XM70/XM90, easily accessible by the operator, and marked as the *disconnecting device* for the controller.
- **DO NOT** run AC power wires in the same wire bundle with input/output wires; failure to comply may cause the expansion module to malfunction due to electrical noise.
- 18 AWG copper wire is recommended for the circuit between the transformer and the expansion module.



Power Budget

XM30 and XM32 Module Power Requirements

The XM30 and XM32 expansion modules are DC powered, typically through the use of an IMC link. The XM70/XM90 is AC powered and can power up to two additional devices (see ["Communication Wiring Examples,"](#) p. 15.)

Table 7. Expansion module power input and power draw

Module	Power Input	Power Draw (mA)
XM30 expansion module	24 Vdc	120
XM32 expansion module	24 Vdc	100
XM70 expansion module	24 Vac	26 VA plus a maximum of 12 VA for each binary output
XM90 expansion module	24 Vac	50 VA plus a maximum of 12 VA for each binary output



Installing the Tracer Expansion Modules

This section provides installation information for the following:

- Tracer XM30 Expansion Module
- Tracer XM32 Expansion Module
- Tracer XM70 Expansion Module
- Tracer XM90 Expansion Module

Expansion modules provide additional hardware terminations when needed for Tracer UC400, Tracer UC600, Symbio 210/210e, Symbio 500, and Symbio 800 applications. Each of the expansion modules listed above vary in the type and capability of expansion; In some cases, additional Tracer PM014 DC power supply modules are required (part number: X13651538010).

Mounting and Removing Tracer Devices

Tracer unit controllers and expansion modules should be properly mounted on a DIN rail. Control cabinets that include DIN rails are available from Trane.

To mount or remove the controller from the DIN rail, follow the illustrated instructions. If using a DIN rail from another manufacturer, follow the recommended installation procedures that accompany it.

Important: *When mounting the controller in a control cabinet, provide adequate spacing between modules to allow for ventilation and heat dissipation.*

NOTICE

Enclosure Damage!

Failure to follow instructions below could result in damage to the plastic enclosure.

Do not use excessive force to install the controller on the DIN rail. If using another manufacturer's DIN rail, follow their recommended installation.

To mount the device:

1. Hook device over top of DIN rail.
2. Gently push on lower half of device in the direction of arrow until the release clip clicks into place.

To remove/reposition the device:

3. Disconnect all connectors before removing or repositioning.
4. Insert screwdriver into slotted release clip and gently pry upward with the screwdriver to disengage the clip.
5. While holding tension on the clip, lift device upward to remove or reposition.

If repositioned, push on the device until the release clip clicks back into place to secure the device on the DIN rail.



Installing the Tracer Expansion Modules

Figure 4. Mounting and removing the device

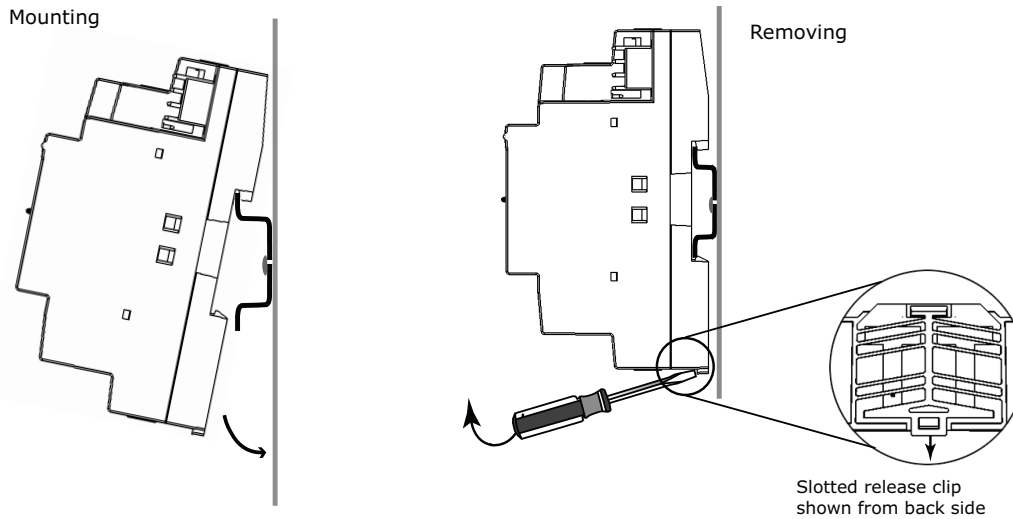

Setting Rotary Switch Addresses

All Tracer expansion modules are required to have unique rotary switch addresses, which can range from 01–99.

It is best practice to develop an addressing scheme before setting rotary switches. This not only prevents address duplication, but decreases the time spent on configuration.

Note: Duplicated addresses will not cause communication problems with remaining modules.

Disconnect power from the unit controller before addressing rotary switches.

Set the two rotary dials on the front of the expansion modules using a 1/8 in. (3 mm) flathead screwdriver. Valid address are 01–99.

Figure 5. Setting rotary switches

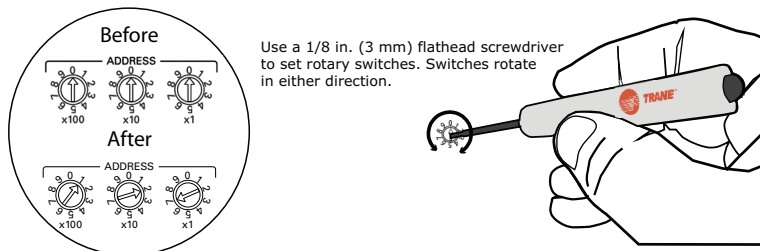

IMC Communication and Power Wiring

This section describes how to connect communication and power wiring for expansion modules. The methods range from basic to complex, depending on the type and number of expansion modules that are used. Communication between modules also depends on the available DC power supplied by the unit controller or the PM014 power supply module.

Observe the following when connecting communication wiring:

- 24 Vdc power is supplied by the UC400, UC600, Symbio210/210e, Symbio 500 for up to two XM30/XM32 expansion modules.
- A PM014 power supply module is required for applications that require more than two XM30/XM32 expansion modules.

IMC Harness Pins

The IMC harness connector provides communication and power among devices on a link. It is important to know the function for each of the IMC pins. In some cases, the red +24 Vdc wire that provides power may need to be removed.

Figure 6. IMC Harness Pins

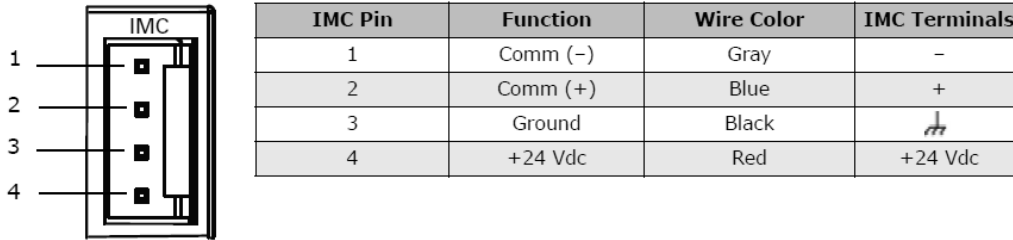

Table 8. IMC harness part numbers

Part Number	Description
X19070636020	Cable, wire harness double housing 3 cond., 18 AWG
X19070636010	Cable, wire harness double housing 4 cond., 18 AWG

Communication Wiring Examples

Figure 7, p. 15 illustrates an example of a typical installation where the IMC harness/IMC terminals provide both 24 Vdc power and IMC communications.

- The Symbio 500 is powered by the 24 Vac input (provided by the UL-listed transformer).
- The XM30 and XM32 are powered by 24 Vdc through the IMC link that is connected to the Tracer UC400/UC600, Symbio 210/210e/500.

Figure 7. Example of a typical installation: two expansion modules and one Symbio 500 programmable controller

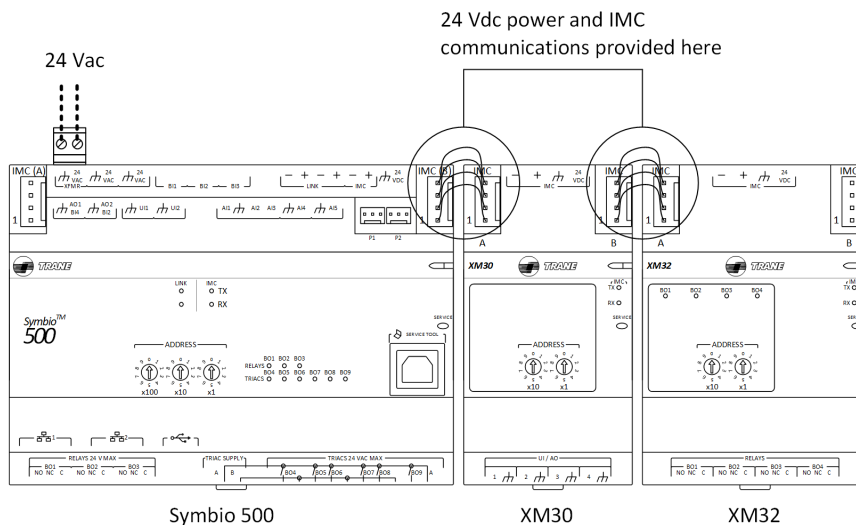

Notes:

- *Comm links are supervised and all circuits are power limited.*
- *Refer to for wiring best practices and constraints.*

Installing the Tracer Expansion Modules

Figure 8, p. 16 illustrates an application with more than two expansion modules, which requires the use of a PM014 power supply module. In this scenario, the Symbio 500 only provides power and IMC communications for the first two expansion modules.

Observe the following when using this method:

- The IMC harness/IMC terminals that connect the second expansion module to the PM014 must not transmit 24 Vdc. Remove the bottom (red) wire from the IMC cable harness.
- The PM014 can provide power for an additional 11 expansion modules.
- The Symbio 500 provides 24 Vdc power for the first two expansion modules that are positioned on the left side as shown in the figure below.
- The PM014 provides power for the two expansion modules that are on positioned on the right side of the PM014 in the figure below.
- The transformer provides 24 Vac input power for the Symbio 500 and the PM014.

Note: The above guidelines also apply when using a Tracer UC400/UC600, Symbio 210/210e controller.

Figure 8. Applications requiring more than two expansion modules

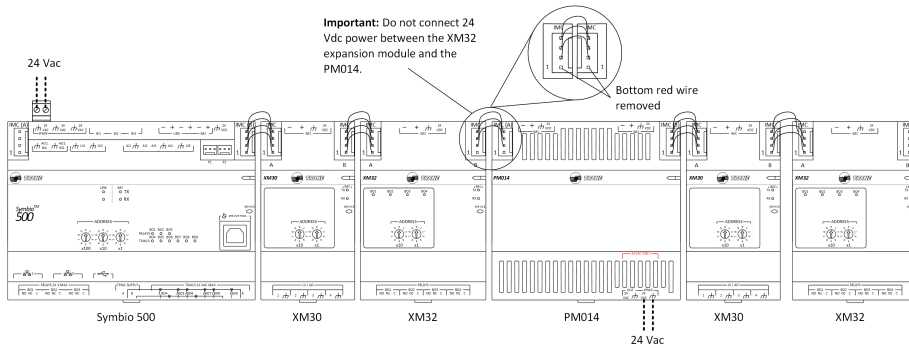

Notes:

- Comm links are supervised and all circuits are power limited.
- Refer to for wiring best practices and constraints.

Figure 9, p. 16 illustrates an application where an XM70/XM90 is used to provide power for two additional expansion modules. On this link a total of four expansion modules can be added.

- Vac input power is provided by the transformer (for Symbio 500 and XM70/XM90)
- Maximum of two expansion modules can be powered by the Symbio 500 24 Vdc through the IMC cable.
- Maximum of two expansion modules can be powered by the XM70/XM90 through the IMC cable.
- The IMC cable between the expansion module powered by the Symbio 500 DC power and the XM70/XM90 must have the 24 Vdc wire removed.
- Connect the modified IMC cable between the XM30 that is powered from the Symbio 500 and the XM70/XM90.
- The XM70/XM90 can power up to two XM30 or XM32 expansion modules.

Figure 9. Symbio 500 application with an XM70/XM90 and multiple expansion modules

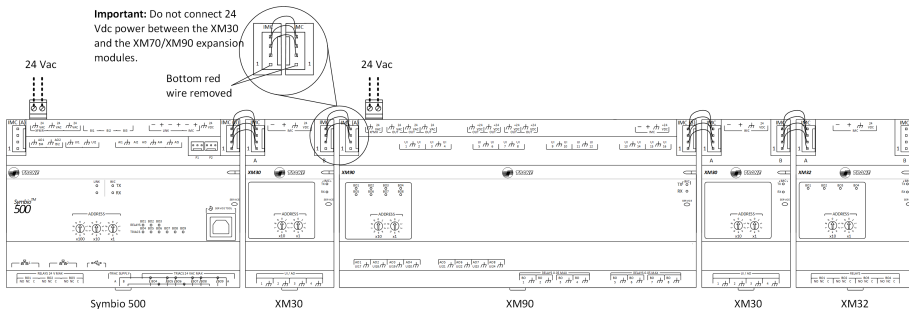

Notes:

- *Comm links are supervised and all circuits are power limited.*
- *Refer to for wiring best practices and constraints.*

Figure 10, p. 17 illustrates an application with two XM70/XM90 expansion modules. When connecting multiple XM70/XM90 modules, the +24 Vdc must be removed between each Tracer UC400/UC600, Symbio 210/210e/500/800 and each XM70/XM90.

- Vac input power is provided by the transformer (for Symbio 500 and each XM70/XM90 module)
- Maximum of two expansion modules can be powered by the XM70/XM90 through the IMC cable.
- The IMC cable between the Symbio 500 and the XM70 must have the 24 Vdc wire removed
- The IMC cable between the two XM70/XM90 modules must have the 24 Vdc wire removed.

Figure 10. Symbio 500 application with two XM70/XM90 modules

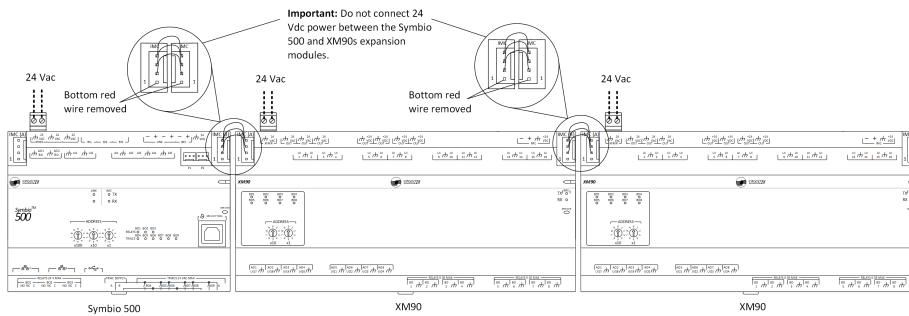

Notes:

- *Comm links are supervised and all circuits are power limited.*
- *Refer to for wiring best practices and constraints.*

Figure 11, p. 17 illustrates a Symbio 500 application with an XM70/XM90, XM32, and an XM30 expansion module.

- The Symbio 500 is powered by the 24 Vac input (provided by the UL-listed transformer).
- The IMC cable between the the XM70 and the Tracer UC400/600, Symbio 210/210e/500/800.
- The XM70/XM90 can power up to two XM30 or XM32 expansion modules.

Figure 11. Symbio 500 application with XM70/XM90, XM32, and XM30 modules

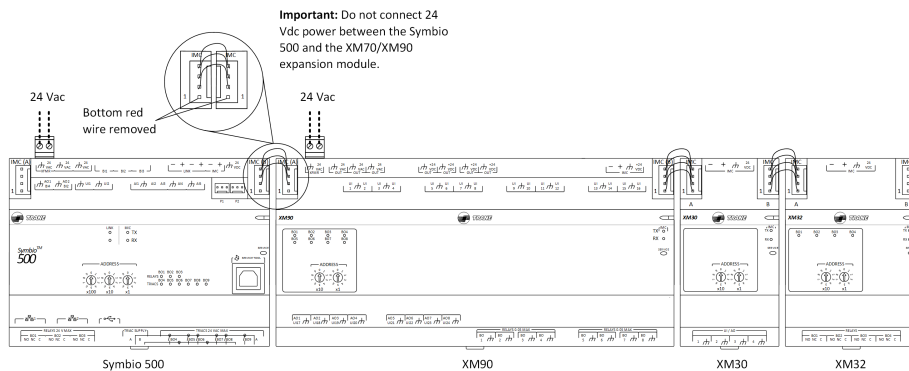

Notes:

- *Comm links are supervised and all circuits are power limited.*
- *Refer to for wiring best practices and constraints.*

Figure 12, p. 18 illustrates a Symbio 800 application with two XM30 and two XM32, where the IMC harness/IMC terminals provide both 24 Vdc and IMC communications. For Symbio 800 applications, a PM014 power supply module is always required to provide 24 Vdc power supply to the controller.

- The PM014 is powered by the 24 Vac input (provided by the UL-listed transformer).

Installing the Tracer Expansion Modules

- The Symbio 800 is powered by 24 Vdc provided by the PM014 power supply module.
- The XM30 and XM32 expansion modules are powered by 24 Vdc through the IMC link that is connected to the Symbio 800.

Figure 12. Symbio 800 application example with four expansion modules

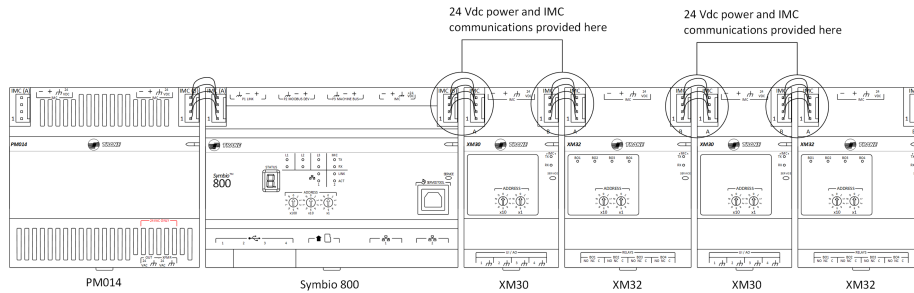

Notes:

- *Comm links are supervised and all circuits are power limited.*
- *Refer to for wiring best practices and constraints.*

Figure 13, p. 18 illustrates a Symbio 800 application example with an XM70/90 and two XM30/XM32 modules. In this case the PM014 will provide 24 Vdc power to the Symbio 800 and the two XM30/XM32 expansion modules through the IMC harness/terminals. The XM70/90 are powered by 24 Vac transformer.

- The PM014 and the XM70/XM90 is powered by the 24 Vac input (provided by the UL-listed transformer).
- The Symbio 800 is powered by 24 Vdc provided by the PM014 power supply module.
- The XM30 and XM32 expansion modules are powered by 24 Vdc through the IMC link that is connected to the Symbio 800.
- The IMC cable between the expansion module, powered by the PM014, and the XM70/XM90 must have the 24 Vdc wire removed.
- Connect the modified IMC cable between the XM32 and the XM70.

Figure 13. Symbio 800 application with XM70/XM90 expansion modules

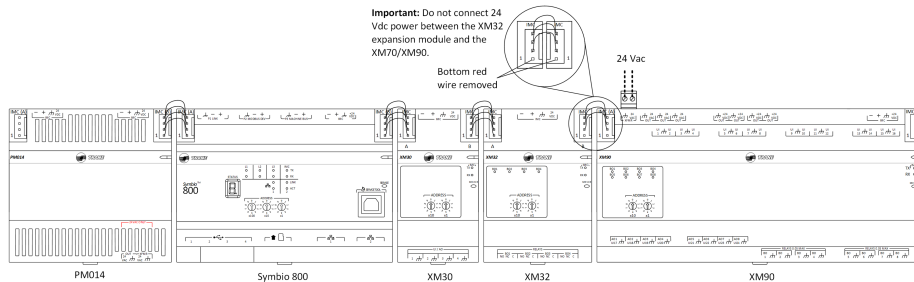

Notes:

- *Comm links are supervised and all circuits are power limited.*
- *Refer to for wiring best practices and constraints.*

Remote Mounting

Expansion modules can be mounted remotely by extending the communication and power wiring from the IMC terminals.

Observe the following when mounting remotely:

- Maximum length of communication wiring cannot exceed 656 ft. (200 m).
Note: *All modules must be wired using a daisy-chain configuration. See BACnet Wiring Best Practices, (BAS-SVX51*-EN) for more information.*
- Twisted pair 18 gauge wiring is required for IMC communication.
- A maximum of 2 expansion modules can be powered from a Tracer UC400/UC600, Symbio 210/210e/500.

Installing the Tracer Expansion Modules

- The Tracer UC400/UC600, Symbio 210/210e/500 can power up to two XM30/32 modules without requiring the addition of a PM014 Power Supply Module.

Figure 14, p. 19 illustrates a basic example of remote mounting where expansion modules are locally powered [power is supplied off of a Tracer UC400/UC600, Symbio 210/210e/500 (when using a Symbio 800 a PM014 must be used)]. A maximum of two expansion modules can be powered locally.

Additional expansion modules require the use of a PM014 power supply module.

Figure 14. Mounting expansion modules remotely

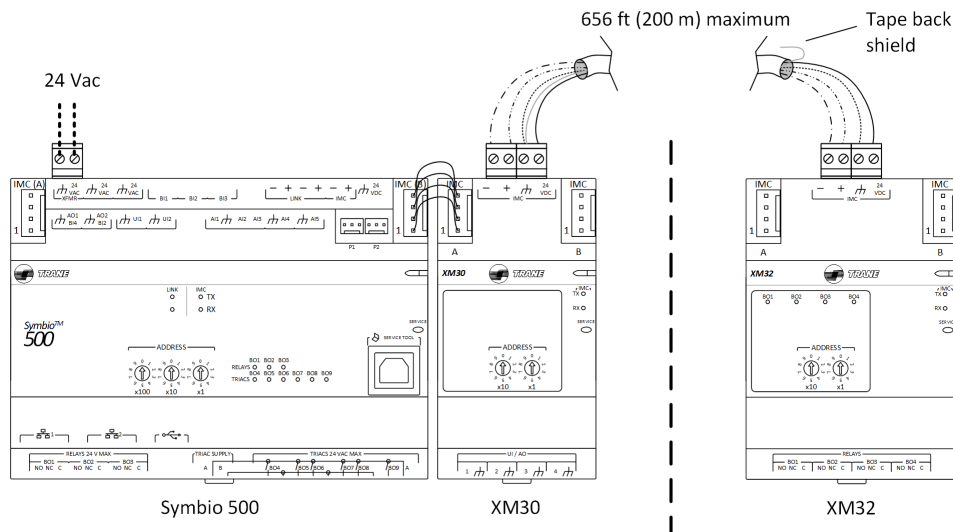

Notes:

- Comm links are supervised and power limited.
- Refer to for wiring best practices and constraints.

Figure 15, p. 20 illustrates an advanced example of remote wiring, which includes a PM014 power supply module. This method is required if more than two expansion modules are powered from a Tracer UC400/UC600, Symbio 210/210e/500 (when using a Symbio 800 a PM014 must be used).

Do the following if using this method:

- Remove the +24 Vdc wire from both the expansion module and the PM014 power supply module.
- Run both IMC and 24 Vdc.
- Remotely mounted expansion modules must have a common ground plane:
 - Ensure that the chassis ground wire is connected between modules that mounted remotely.



Installing the Tracer Expansion Modules

Figure 15. Remote mounting with the use of a PM014 power supply

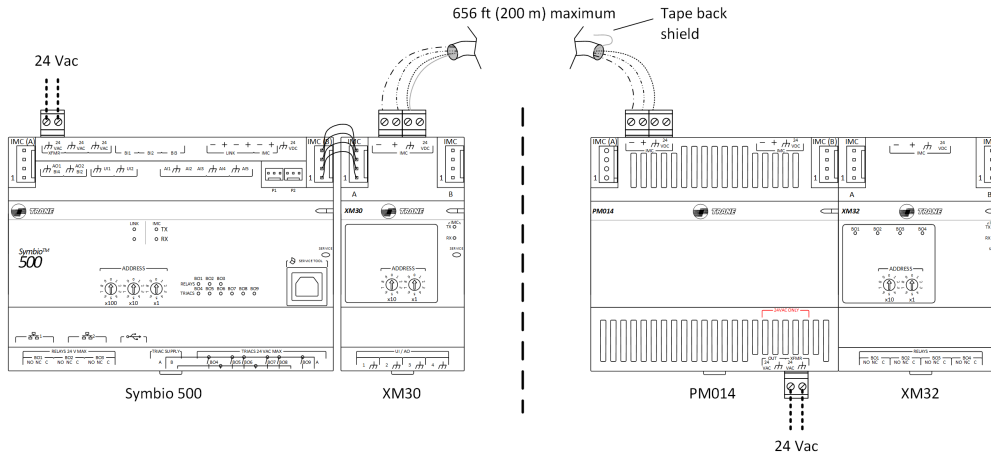

Notes:

- Comm links are supervised and power limited.
- Refer to for wiring best practices and constraints.

AC Power Warnings and Notices

⚠ WARNING

Hazardous Voltage!

Failure to disconnect power before servicing could result in death or serious injury.

Disconnect all electric power, including remote disconnects before servicing. Follow proper lockout/tagout procedures to ensure the power can not be inadvertently energized. Verify that no power is present with a voltmeter.

⚠ WARNING

Proper Ground Connection Required!

Failure to follow instructions below could result in death or serious injury.

After installation, ensure that the 24 Vac transformer is grounded through the controller. Measure the voltage between chassis ground and any ground terminal on the controller. Expected result: Vac <4.0 volt.

NOTICE

Equipment Damage!

Failure to follow instructions below could result in damage to the controller, power transformer, or input/output devices due to inadvertent connections to power circuits.

Remove power to the controller before making input/output connections.

Important: AC wiring must be in conformance with the specifications for each device and comply with National Electrical Code and local electrical code.

Terminal Wiring Requirements

Table 9. Maximum wire lengths

Type	Inputs	Outputs
Binary	1,000 ft (300 m)	1,000 ft (300 m)
0 to 20 mA	1,000 ft (300 m)	1,000 ft (300 m)
0 to 10 Vdc	300 ft (100 m)	300 ft (100 m)
Thermistor/Resistive	300 ft (100 m)	Not Applicable

Notes:

1. All wiring must be in accordance with the NEC and local codes.
2. Use only 18 to 22 AWG (1.02 mm to 0.65 mm diameter), stranded, tinned-copper, shielded, twisted-pair wire.
3. Analog and 24 Vdc output wiring distances are dependent on the receiving unit specifications.
4. DO NOT run input/output wires or communication wires in the same wire bundle with AC power wires.

Transformer Requirements

- AC transformer requirements: UL listed, Class 2 power transformer, 24 Vac \pm 10%, device max load 26 VA. The transformer must be sized to provide adequate power to the XM70 expansion module (26 VA), XM90 (30 VA) and outputs (maximum 12 VA per binary output).
- CE-compliant installations: The transformer must be CE marked and SELV compliant per IEC standards.

NOTICE

Equipment Damage!

Sharing 24 Vac power between controllers could result in equipment damage.

A separate transformer is recommended for each controller. The line input to the transformer must be equipped with a circuit breaker sized to manage the maximum transformer line current.

If a single transformer is shared by multiple XM70/XM90 and the main controller devices:

- The transformer must have sufficient capacity.
- Polarity must be maintained for every device powered by the transformer.

Important: *If polarity is inadvertently reversed between controllers that are powered by the same transformer, a difference of 24 Vac will occur between the grounds of each controller. The following symptoms could result:*

- *Partial or full loss of communication on the entire BACnet MS/TP link*
- *Improper function of XM70/90 expansion module outputs*
- *Damage to the transformer or a blown transformer fuse*

Wiring AC Power to the XM70/90

1. Disconnect all power including remote connections.
2. Connect one secondary wire from the 24 VAC transformer to the chassis ground terminal 
3. Connect the other secondary wire to the 24 Vac terminal.

Note: *A pigtail connection is necessary between the earth ground and chassis ground if the device is not earth-grounded through one leg of the transformer wiring. The XM70/90 expansion module is not earth-grounded through the enclosure.*

Note: *The XM70 is shown in the following figure. The XM90 is similar.*

Installing the Tracer Expansion Modules

Figure 16. Wiring AC power

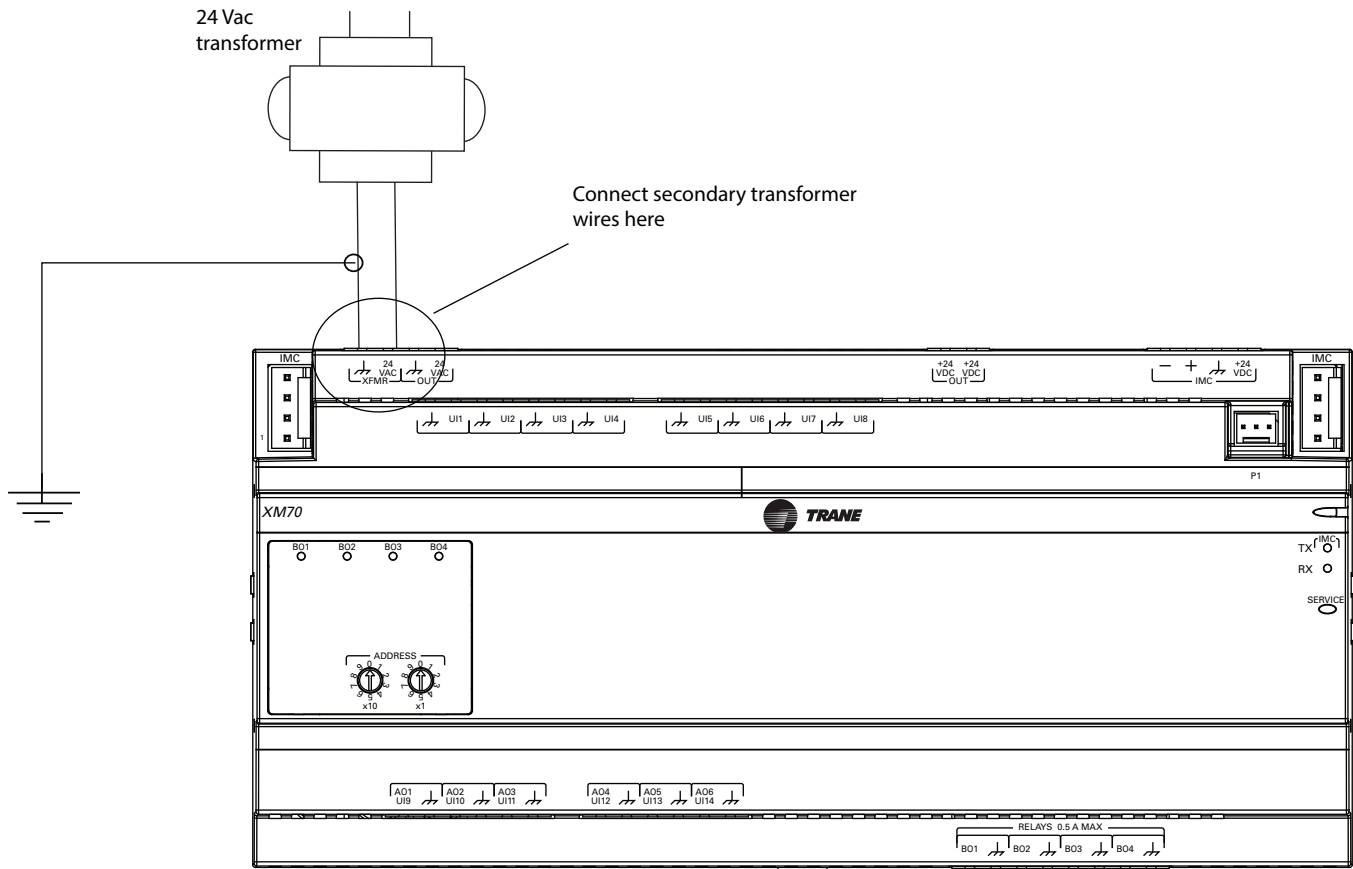

Configuring the Expansion Modules

Ensure that the following tasks have been completed before applying power to the expansion modules:

- Carefully review all IMC communication and power wire guidelines as described in “[IMC Communication and Power Wiring](#),” p. 14.
- Set a unique and valid rotary switch address for each device (“[Setting Rotary Switch Addresses](#),” p. 14).

To configure the expansion modules:

- Apply power to the controller, the expansion modules, and the PM014 power supply module (if applicable).
- Verify that all expansion modules are powered up by observing the (RX) LEDs, which blink when communication occurs between the devices. See [Table 10](#), p. 24.
- Open the Tracer TU™ service tool and establish a direction connection to the controller by using a USB cable or a BACnet link discovery.
- From the Utilities menu, click Utilities/Status/Controller settings.
- Open the Expansion Module group box.
- From the **Add drop-down** list, select the module you want to add and then click Go. Only one module can be selected at a time. This populates a table containing the modules ([Figure 17](#), p. 23).
- Verify that the correct address is displayed for each module in the **Address** field. If not, set the appropriate rotary addresses. A rotary dial setting of **01 equals 1** in the **Address** field. For help see “[Troubleshooting](#),” p. 25.
- Click the **Send to Device** button.
- This action saves the configuration to the controller and initiates discovery on the IMC link. The TX/RX LEDs on the expansion module will blink when the IMC communication to the expansion module is configured. Tracer TU displays **Device Discovery Complete** when the discovery process is complete.

Note: You can continue to add additional modules as described in the above procedure. The total number of terminations on a Symbio 500 link cannot exceed 133. For example, if you reached 132 terminations, additional modules cannot be added because expansion modules have four or more terminations (all terminations on a module are accounted for).

Figure 17. Expansion modules group box (Tracer TU)

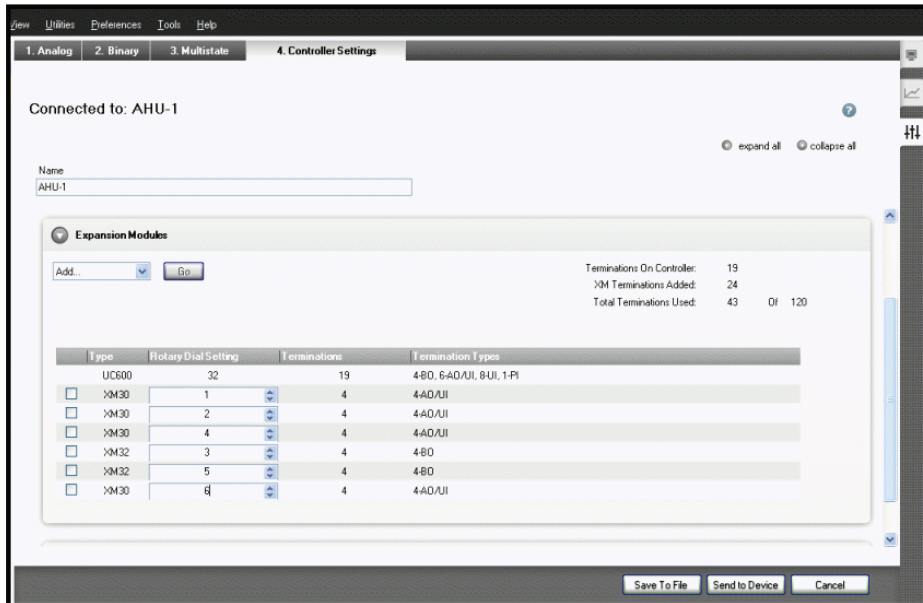



Expansion Module Operation

After applying power to the expansion modules, the transmitting (TX) and receiving (RX) LEDs blink when communication occurs between devices. The following table describes LED activity and indicators.

Table 10. LED identification and interpretation

LED type	LED activity	Indicates...	Troubleshooting/Notes
Power	Solid green	Normal operation	Sequence on power-up: Illuminates red, then green.
	Solid red	Low voltage or malfunction	
Service	Solid green	LED has been pressed and remains on until powered down	Sequence on power-up: One short blink upon power-up or during memory test; will remain green if memory test fails. When the service LED is pressed, the module will continue to use its normal node number for communication. However, it will communicate node 0 if possible (this does not affect operation).
	LED not illuminated	Normal operation	
Binary outputs (BO1 through BO8)	Solid yellow	Binary output is On/Energized.	—
	LED not illuminated	Binary output is Off/De-energized.	—

Troubleshooting

This section describes possible solutions for communication and status errors that may occur after the modules have been configured (see “[Configuring the Expansion Modules](#),” p. 22).

Note: By clicking the *Discover Modules* button, you can locate addresses of modules without defining them.

Communication

Problem:

Points that are referencing expansion modules are in fault or not controlling.

Solution:

1. Verify that the expansion modules are powered.
2. Visually verify that all modules are communicating (both the TX and RX lights are blinking).
3. In Tracer TU, navigate to the **Utilities/Controller/Controller Status** screen.
4. In the Expansion Module Status section, confirm that all modules are communicating. After clicking **Send to Device**, if errors appear in the Errors column see Status Errors below.

Status Errors

Error messages that appear in the Tracer TU Expansion Module Status screen are explained here.

Figure 18. Possible expansion module errors (Tracer TU)

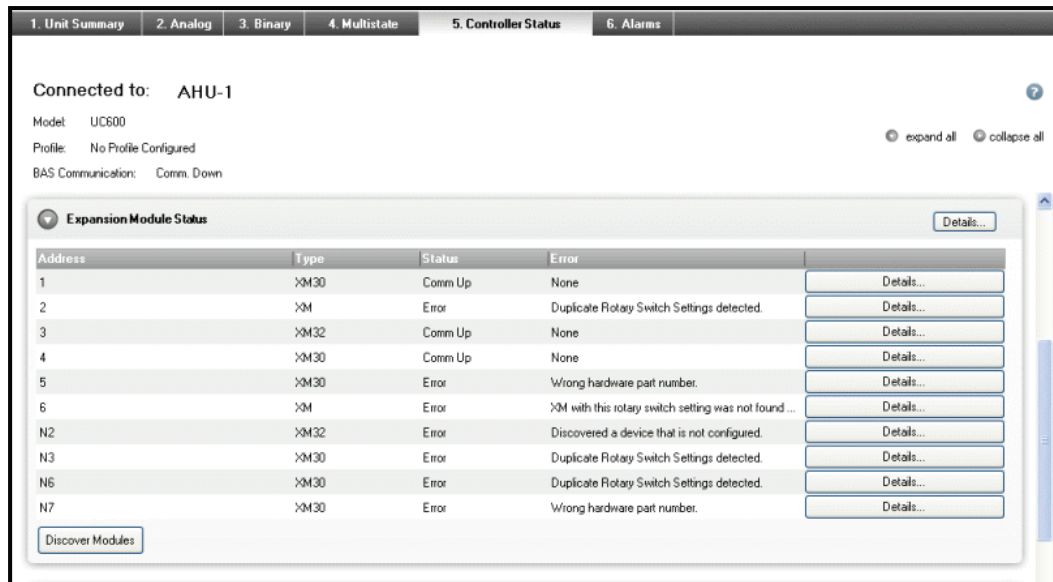

Address	Type	Status	Error	Details...
1	XM30	Comm Up	None	Details...
2	XM	Error	Duplicate Rotary Switch Settings detected.	Details...
3	XM32	Comm Up	None	Details...
4	XM30	Comm Up	None	Details...
5	XM30	Error	Wrong hardware part number.	Details...
6	XM	Error	XM with this rotary switch setting was not found ...	Details...
N2	XM32	Error	Discovered a device that is not configured.	Details...
N3	XM30	Error	Duplicate Rotary Switch Settings detected.	Details...
N6	XM30	Error	Duplicate Rotary Switch Settings detected.	Details...
N7	XM30	Error	Wrong hardware part number.	Details...

Error: Duplicate rotary switch settings detected

Another expansion module with the same rotary switch setting is present on the IMC link.

Solution: Change the incorrectly addressed module to match its configuration.

1. Navigate to the **Utilities/Controller/Controller Settings** screen.
2. Using the configurations shown in the Expansion Module Status frame, visually verify that all modules have been addressed correctly. When the improperly addressed module is found, readdress the module to match the configured address.
3. Navigate to the **Utilities/Status/Controller Settings** screen; click **Send to Device**.
4. Verify that Error has cleared from list.

Error: Discovered a device that is not configured

Problem: An expansion module was discovered on the IMC link that was not configured.

Solution: configure the module (see “Configuring the Expansion Modules,” p. 22).

Note: An un-configured module will not cause communication issues; however, it will not have referencing capability.

Error: Wrong hardware part number

Problem: An expansion module was discovered on the IMC link that was not configured.

Solution: Reconfigure the module in the Utilities/Status/Controller Settings screen to match the hardware configuration or replace the device with the correct hardware (XM module).

Error: XM with this rotary switch setting was not found

Problem: A configured module was not found on the IMC link. This could be caused by one of the following:

- Module is now powered.
- The remote mounted communication link is not connected.
- The rotary address on the expansion module was incorrectly set.

Solution: Apply power to the module (if applicable), correct the remote communication on the link, or re-address the module to match the configuration.

Commissioning and Troubleshooting in a Powered State

This section provides instructions for testing the expansion module points after establishing a connection and applying power. The step numbers or method numbers in each figure correspond to the information in each table.

The following equipment is required in order to test inputs and outputs:

- Digital multimeter (DMM)
- Small flat-bladed screwdriver

Resistive Inputs

Table 11. Resistive inputs

Checkout Procedure	Measurement	Expected Value
Step 1	Measure AC voltage across the resistive termination	Vac ≈ 0.0 V AC voltage will affect further measurement
Step 2	Measure DC voltage across the resistive termination	See the charts below

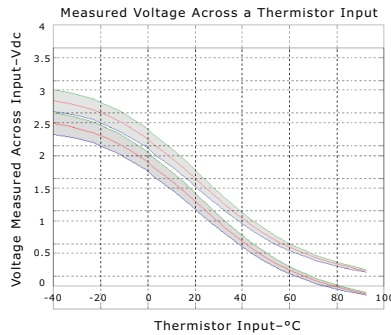
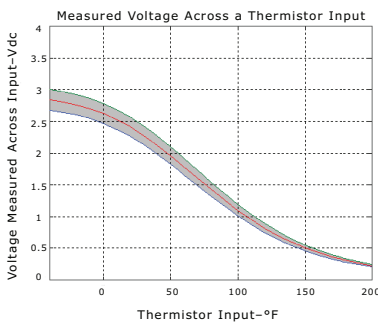
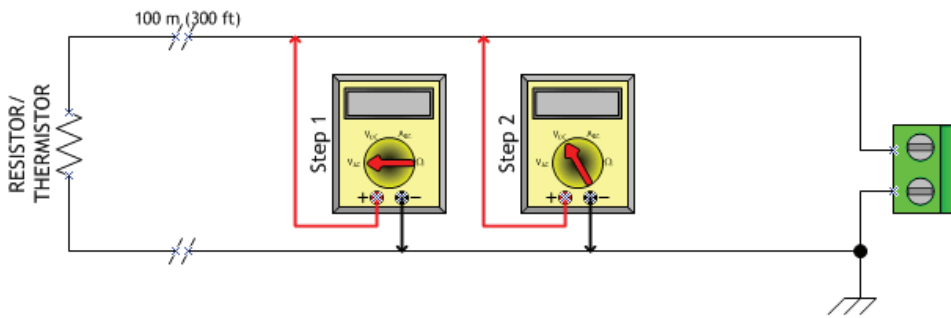

Charts show measurements across thermistor input (Fahrenheit and Celsius) and resistive input.

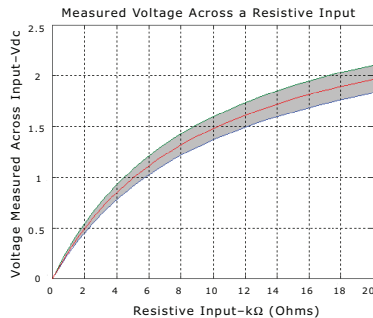

Voltage Inputs

Table 12. Voltage inputs

Checkout Procedure	Measurement	Expected Value
Step 1	Measure AC voltage across the voltage termination	$V_{ac} \approx 0.0\text{ V}$ AC voltage will affect further measurement
Step 2	Measure DC voltage across the voltage termination	Compare to input status in Tracer TU

Figure 19. Voltage input

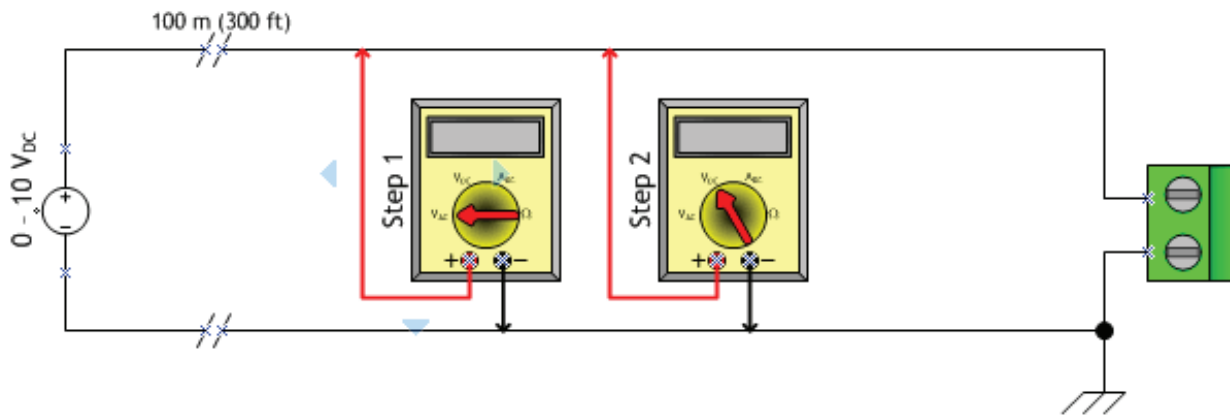

Current Inputs

Method 1

Table 13. Method 1

General Information	Checkout Procedure	Measurement	Expected Value
Method 1 capitalizes on the very low input resistance of a DMM in current measurement mode. However, this method affects the value that the expansion module will use while controlling outputs. When the meter is set to current mode, the current flowing into the expansion module circuit will drop to zero or near zero.	Step 1	Measure AC voltage across the current input	$V_{ac} \approx 0.0\text{ V}$ AC voltage will affect further measurement
	Step 2	Measure DC current across the current input	Compare to input status in Tracer TU

Figure 20. Method 1

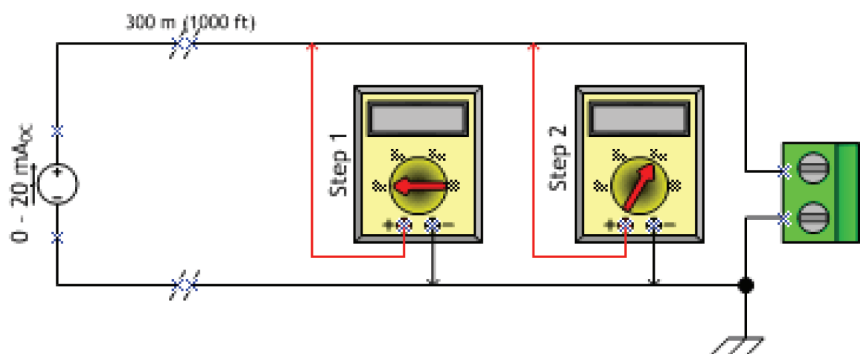

Method 2

Table 14. Method 2

General Information	Checkout Procedure	Measurement	Expected Value
Method 2 is less disruptive to the system. In voltage mode, the DMM affects the circuit less. Additional information is needed to translate the voltage measured to current flowing through the circuit.	Step 1	Measure AC voltage across the voltage input	Vac ≈ 0.0 V AC voltage will affect further measurement
	Step 2	Measure DC voltage across the voltage termination	Refer to the chart below

Figure 21. Method 2

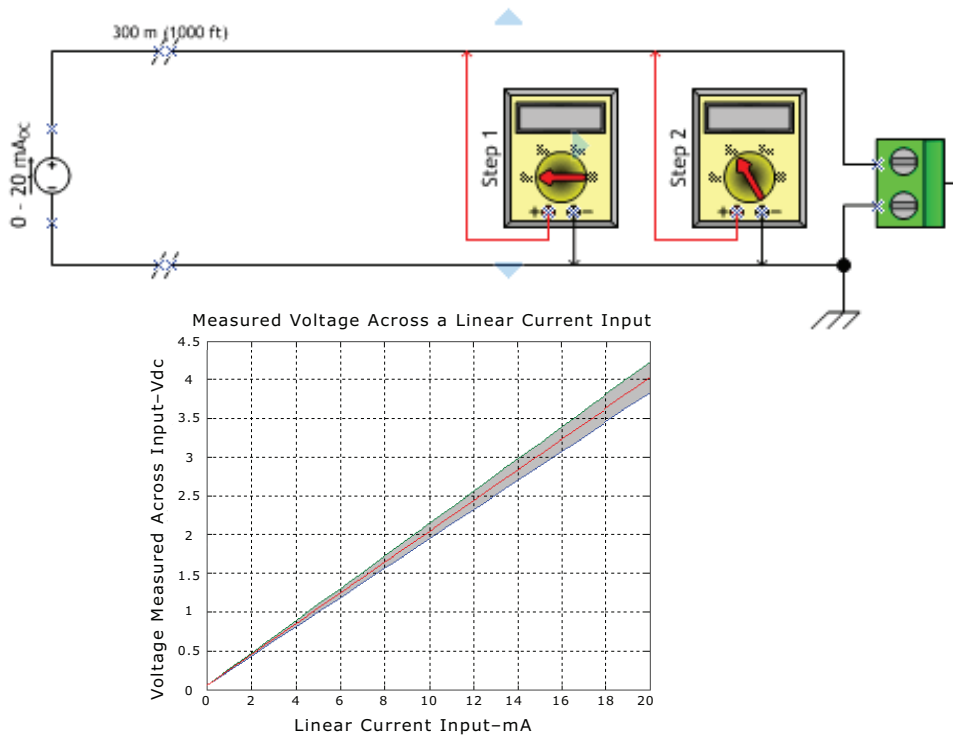

Binary Inputs: 24 Vac Detect (Methods 1 or 2)

Table 15. Methods 1 or 2

General Information and Checkout Procedure	Measurement	Expected Value
Method 1: Voltage across binary input measured without reference to chassis ground.	Measure AC voltage across the binary input	Vac ≈ 0.0 V (state = ON) Vac ≈ 24.0 V (state = OFF)
Method 2: Voltage across binary input measured with reference to chassis ground. Any connection with chassis ground symbol can serve as a ground reference for this method.	Measure DC voltage across the binary input	Vac ≈ 0.0 V (state = OFF) Vac ≈ 24.0 V (state = ON)

Figure 22. Methods 1 or 2

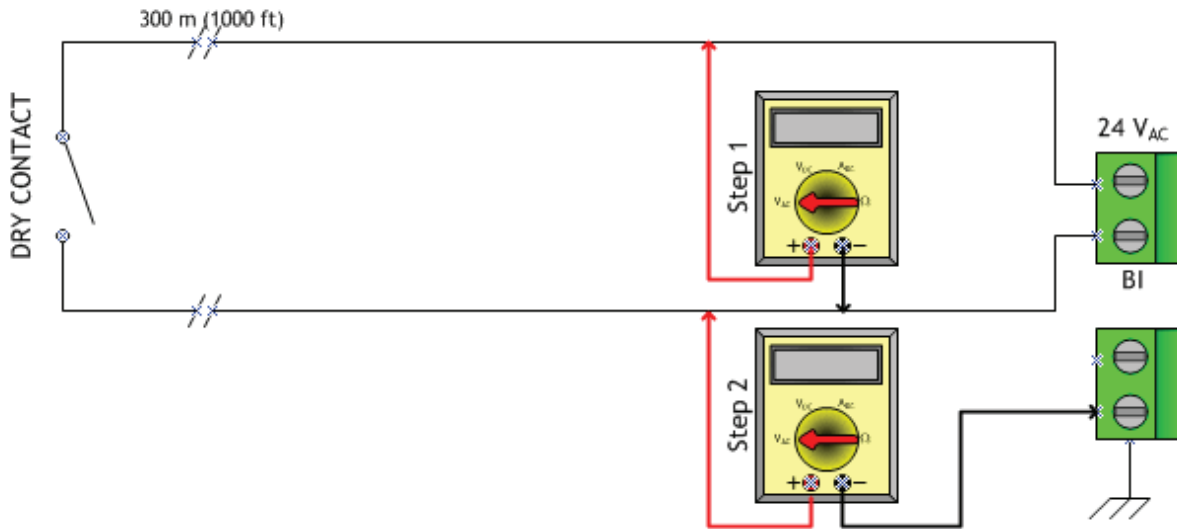

Binary Inputs: Based on Analog Output Connection

Table 16. Binary input

General Information	Checkout Procedure	Measurement	Expected Value
The UC600 module analog output connections can be configured as binary inputs. This can be used only with dry contact or open collector-type sensors.	Step 1	Measure AC voltage across the binary input	$V_{ac} \approx 0.0 \text{ V}$ AC voltage will affect further measurement
	Step 2	Measure DC voltage across the binary input	$V_{dc} \leq 2.0 \text{ V}$ (state = ON) $V_{dc} \geq 2.0 \text{ V}$ (state = OFF)

Figure 23. Binary input

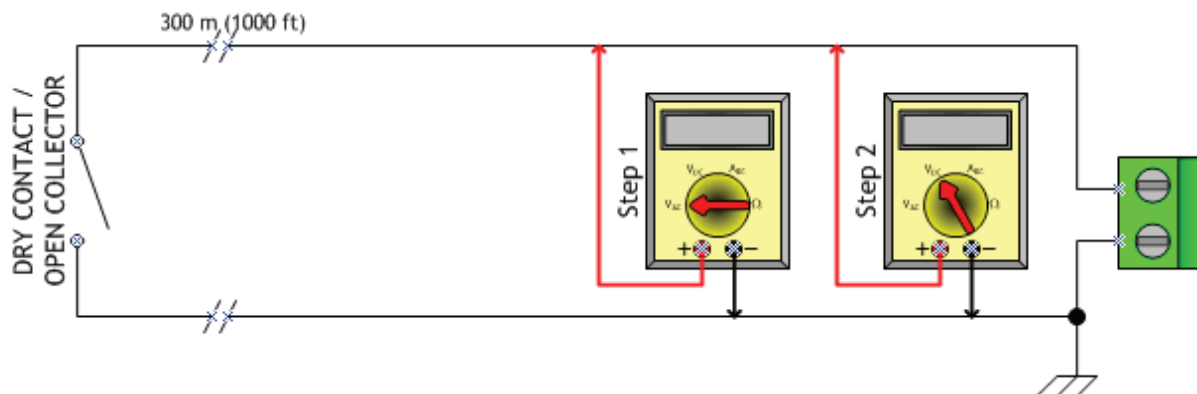

Voltage Analog Output

Table 17. Voltage analog output

Measurement Procedure	Expected Value
Measure DC voltage across the voltage termination	Compare to the expected value based on request from controller. This request may be based on an override of the output value.

Figure 24. Voltage analog output

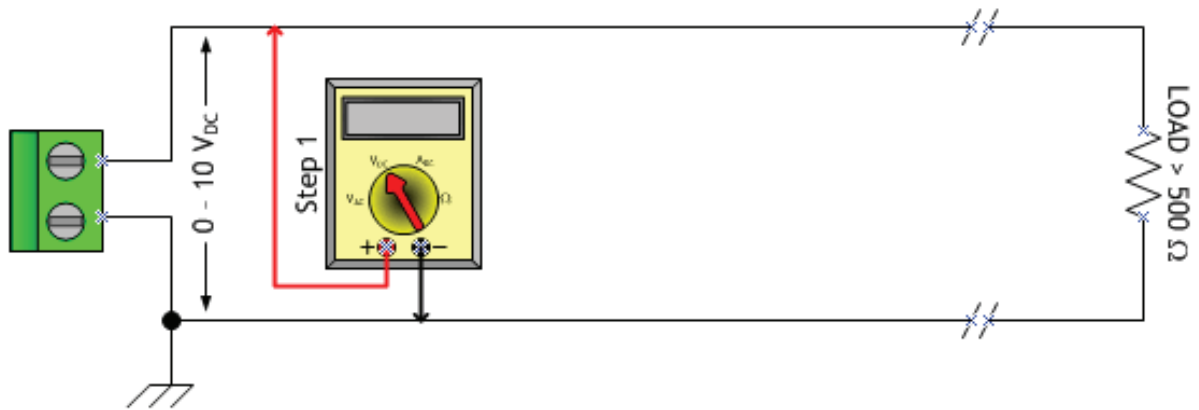

Current Analog Output (Methods 1 or 2)

Table 18. Methods 1 or 2

General Information and Checkout Procedure	Measurement	Expected Value
Method 1: Shorting the current output- this method leaves the circuit intact, however, it will cause the vast majority of the current to flow through the meter instead of the load (NOTE LOAD RESISTANCE).	Measure DC current across the current termination	Compare expected value based on request from controller. This request may be based on an override of the output value.
Method 2: Measuring current directly- this method is most the typical way to measure current and has the advantage of leaving the load in the loop. However, the circuit must be broken when using this method.	Measure DC current across the current termination	Compare expected value based on request from controller. This request may be based on an override of the output value.

Figure 25. Methods 1 or 2

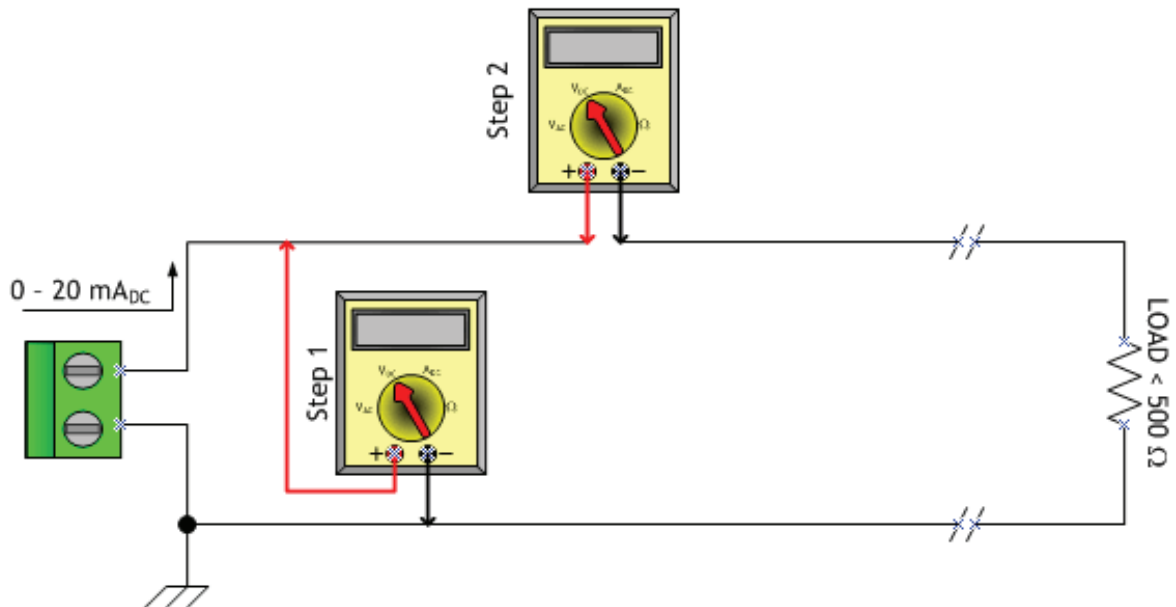

Trane - by Trane Technologies (NYSE: TT), a global innovator - creates comfortable, energy efficient indoor environments for commercial and residential applications. For more information, please visit trane.com or tranetechnologies.com.

Trane has a policy of continuous product and product data improvements and reserves the right to change design and specifications without notice. We are committed to using environmentally conscious print practices.

BAS-SVX46F-EN 30 Jun 2026
Supersedes BAS-SVX46E-EN (March 2020)

©2026 Trane