

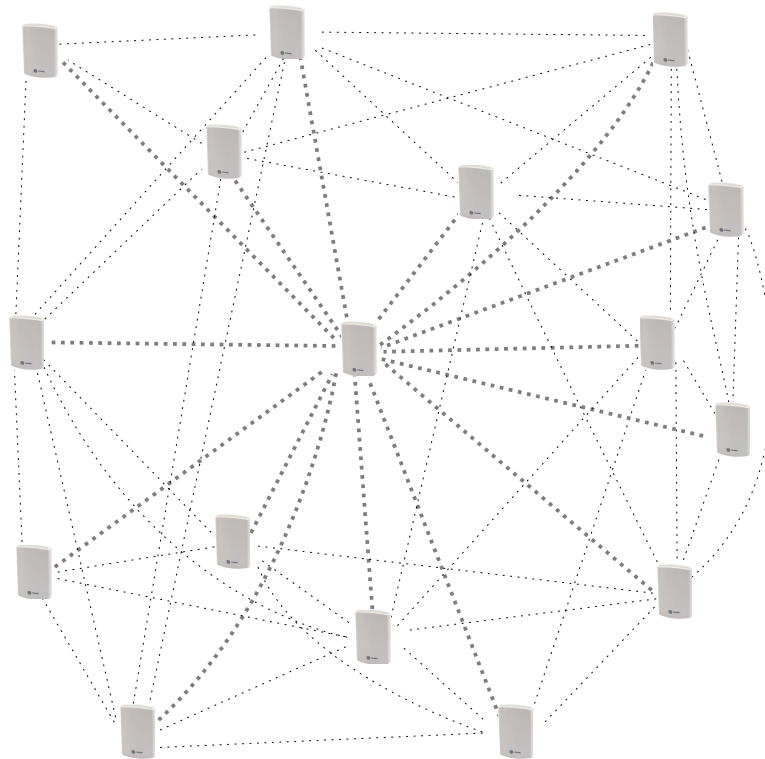

Installation, Operation, and Maintenance **Air-Fi® Wireless System**



⚠ SAFETY WARNING

Only qualified personnel should install and service the equipment. The installation, starting up, and servicing of heating, ventilating, and air-conditioning equipment can be hazardous and requires specific knowledge and training. Improperly installed, adjusted or altered equipment by an unqualified person could result in death or serious injury. When working on the equipment, observe all precautions in the literature and on the tags, stickers, and labels that are attached to the equipment.



Introduction

Read this manual thoroughly before operating or servicing this unit.

Warnings, Cautions, and Notices

Safety advisories appear throughout this manual as required. Your personal safety and the proper operation of this machine depend upon the strict observance of these precautions.

The three types of advisories are defined as follows:



Indicates a potentially hazardous situation which, if not avoided, could result in death or serious injury.



Indicates a potentially hazardous situation which, if not avoided, could result in minor or moderate injury. It could also be used to alert against unsafe practices.



Indicates a situation that could result in equipment or property-damage only accidents.

Important Environmental Concerns

Scientific research has shown that certain man-made chemicals can affect the earth's naturally occurring stratospheric ozone layer when released to the atmosphere. In particular, several of the identified chemicals that may affect the ozone layer are refrigerants that contain Chlorine, Fluorine and Carbon (CFCs) and those containing Hydrogen, Chlorine, Fluorine and Carbon (HCFCs). Not all refrigerants containing these compounds have the same potential impact to the environment. Trane advocates the responsible handling of all refrigerants.

Important Responsible Refrigerant Practices

Trane believes that responsible refrigerant practices are important to the environment, our customers, and the air conditioning industry. All technicians who handle refrigerants must be certified according to local rules. For the USA, the Federal Clean Air Act (Section 608) sets forth the requirements for handling, reclaiming, recovering and recycling of certain refrigerants and the equipment that is used in these service procedures. In addition, some states or municipalities may have additional requirements that must also be adhered to for responsible management of refrigerants. Know the applicable laws and follow them.

⚠ WARNING

Proper Field Wiring and Grounding Required!

Failure to follow code could result in death or serious injury.

All field wiring MUST be performed by qualified personnel. Improperly installed and grounded field wiring poses FIRE and ELECTROCUTION hazards. To avoid these hazards, you MUST follow requirements for field wiring installation and grounding as described in NEC and your local/state/national electrical codes.

⚠ WARNING**Personal Protective Equipment (PPE) Required!**

Failure to wear proper PPE for the job being undertaken could result in death or serious injury. Technicians, in order to protect themselves from potential electrical, mechanical, and chemical hazards, **MUST** follow precautions in this manual and on the tags, stickers, and labels, as well as the instructions below:

- Before installing/servicing this unit, technicians **MUST** put on all PPE required for the work being undertaken (Examples; cut resistant gloves/sleeves, butyl gloves, safety glasses, hard hat/bump cap, fall protection, electrical PPE and arc flash clothing). **ALWAYS** refer to appropriate Safety Data Sheets (SDS) and OSHA guidelines for proper PPE.
- When working with or around hazardous chemicals, **ALWAYS** refer to the appropriate SDS and OSHA/GHS (Global Harmonized System of Classification and Labelling of Chemicals) guidelines for information on allowable personal exposure levels, proper respiratory protection and handling instructions.
- If there is a risk of energized electrical contact, arc, or flash, technicians **MUST** put on all PPE in accordance with OSHA, NFPA 70E, or other country-specific requirements for arc flash protection, **PRIOR** to servicing the unit. **NEVER PERFORM ANY SWITCHING, DISCONNECTING, OR VOLTAGE TESTING WITHOUT PROPER ELECTRICAL PPE AND ARC FLASH CLOTHING. ENSURE ELECTRICAL METERS AND EQUIPMENT ARE PROPERLY RATED FOR INTENDED VOLTAGE.**

⚠ WARNING**Follow EHS Policies!**

Failure to follow instructions below could result in death or serious injury.

- All Trane personnel must follow the company's Environmental, Health and Safety (EHS) policies when performing work such as hot work, electrical, fall protection, lockout/tagout, refrigerant handling, etc. Where local regulations are more stringent than these policies, those regulations supersede these policies.
- Non-Trane personnel should always follow local regulations.

Copyright

This document and the information in it are the property of Trane, and may not be used or reproduced in whole or in part without written permission. Trane reserves the right to revise this publication at any time, and to make changes to its content without obligation to notify any person of such revision or change.

Trademarks

All trademarks referenced in this document are the trademarks of their respective owners.

Revision History

- Updated Air-Fi® Wireless Communications Interface (WCI) section in Overview chapter.
- Updated Maximum Number of Air-Fi® Devices and Networks Allowed section in Overview chapter.
- Updated Specifications section in Overview chapter.
- Updated Agency Compliance section in Overview chapter.
- Updated Design Consideration for BCI-I, BCI-R, BC12-I, BC12-R and Symbio 700 section in Pre-Installation chapter.
- Updated Line of Sight Placement section in Pre-Installation chapter.



Table of Contents

Overview	8
Air-Fi® Wireless Communications Interface (WCI).....	8
Air-Fi® Wireless Communications Sensor (WCS)	8
Compatibility with Previous Generation Wireless Zone Products.....	8
Wired Zone Sensors	8
Devices Supported by Air-Fi® Wireless Systems	8
Maximum Number of Air-Fi® Devices and Networks Allowed.....	9
Automatic Network Formation and Sensor Association	10
Network Security	10
Air-Fi® Device Part Numbers	11
Firmware Requirements for Devices on an Air-Fi® Network.....	11
WCI Dimensions.....	13
WCS-SB/SD Dimensions	14
WCS-SO/SCO2 Dimensions (WCS-SB/R Similar).....	15
Specifications	16
Agency Compliance.....	20
Pre-Installation	21
Location Considerations	21
WCI Positioning	21
Line of Sight Placement	21
WCI Maximum Wire Length	21
WCI Installation Locations	21
WCS Installation Locations.....	22
WCS Height Requirements.....	22
WCS Mounting Surfaces.....	23
Design Consideration for BCI-I, BCI-R, BCI2-I, BCI2-R and Symbio 700.....	23
WCI Installation.....	24
WCI Addressing	24
WCI Mounting and Wiring	25
Controller Applications	25
Repeater Applications	33
Changing a WCI from Device Association to Repeater	34
WCS-SB/SD Installation.....	35
Powering the WCS.....	35
WCS Addressing	35
WCS: Network Joining and Controller Association	39

2% Relative Humidity Sensor Module.....	39
WCS : Points and Referencers	39
Mounting the Sensor Back Plate	40
WCS–SO/SCO ₂ and –SB/R Installation	41
Powering the WCS-SO, -SCO ₂ , -SB/R Sensor	41
Addressing the WCS-SO, -SCO ₂ , -SB/R Sensor	41
WCS-SO, -SCO ₂ , -SB/R Network Joining and Controller Association	44
WCS : Points and Referencers	44
Mounting the WCS-SO, -SCO ₂ , -SB/R Sensor Back Plate	44
Wiring an External Sensor Probe to WCS-SB/R	45
WCS-SO, -SCO ₂ , -SB/R Display Sequence	48
RH Sensor Module Installation.....	50
Replacing the Sensor Cover.....	51
WCS-SO, -SCO ₂ , -SB/R Error Codes.....	51
Testing WCS-to-WCI Signal Strength and Battery Life.....	52
WCS-SB/SD Configuration	53
Configuration Procedure.....	53
Example of a Configured WCS-SD Display	56
Optional Features.....	56
Displaying Setpoint or Temperature	56
Locking or Unlocking Settings	57
Star (*)/Double Star (**) Function	58
Replacing the Sensor Cover.....	58
Viewing Unit Controller Operating Status	59
Establishing an Air-Fi® Network	60
WCI LEDs and Buttons	60
Three Ways to Establish an Air-Fi® Network	62
Establishing the Network After Tracer SC+ Installation	63
Establishing the Network Prior to Tracer SC+ Installation or Without Tracer SC+ Installation	63
Task 1: Activate Communication Among Existing WCIs	63
Task 2: Installing a Tracer SC+ After Network Formation	64
Installing Air-Fi Wireless Sensors with BACnet MS/TP or BACnet/IP	64
Using Tracer TU with Air-Fi® Wireless Sensors and BACnet MS/TP or BACnet/ IP.....	66
Modifying an Air-Fi® Network.....	68
Adding WCIs to an Existing Network Using Tracer TU.....	68

Adding WCIs to an Existing Network Using a WCI	68
Adding Coordinators to a Tracer SC+	68
Removing a WCI from a Network	68
Replacing a WCI on a Network	69
Moving a WCI From One Device to Another	69
Changing the ZigBee® Channel of the Wireless Network	69
Closing the Network	69
Disbanding a Network	69
Troubleshooting and Maintenance	70
WCI Does Not Join Network	70
Tracer SC+ Does Not Communicate with WCI	70
Sensor Does Not Communicate with WCI	71
No Communication	71
Slow Communication	71
ZigBee® and Wi-Fi Channel Information	72
Replacing a Failed WCI	72
Task 1: Remove the failed WCI	73
Task 2: Install the new WCI	73
Testing WCS Signal Quality and Battery Life	74
Checking Signal Quality on a Site	74
Battery Information	75
Manual Association Process	76
Disassociation	76
Replacing a Failed WCS	76
Sensor Output Power Level	77
Cleaning the Sensor	77
Using the Tracer® TU Service Tool with a Wireless Network	78
Requirements for Joining a Wireless Network	78
Joining Tracer TU to a Wireless Network	78
Managing a Wireless Network and Devices	80
Connecting to a Device	80
The Wireless Menu	81
Wireless Sensor Setup	88
Default Sensor Values for Trane® Standard Programs	89
Referencing Individual Sensors	89
BCI/BCI2 Point and Reference Limitations	91
WCS-SB/R Refrigerator Temperature Sensor Setup	93
WCS-SB/R Refrigerator Sensor plus Two Averaged Space Temp Sensors Setup Instructions	94
Setting Up Wireless Battery Monitoring	98

How to Connect Air-Fi® Wireless Sensors Directly to SC+	100
How to Set-up Air-Fi Network on Tracer Synchrony	100
How to Configure Air-Fi Sensors Connected Directly to Tracer SC+ without a Unit Controller	101
Opening Air-Fi Network from Synchrony	102
Configuring WCS Sensor	102
Creating Points to the Sensor	102
Communication History	104
Overview	104
User Interface	105
Channel Quality Scan Tool	106
Channel Quality Scan Tool	107
Overview	107
Changing a Zigbee channel	108
Multiple Uses	109
Scanning and Exporting (saving) scan data	109
Hover Information	110



Overview

This section provides an overview of Trane Air-Fi® wireless systems and the two Trane Air-Fi® wireless devices.

Air-Fi® Wireless Communications Interface (WCI)

The Air-Fi Wireless Communications Interface (WCI) enables wireless communications between system controls, unit controls, and wireless sensors for Trane® control products that use the BACnet® protocol. The WCI replaces the need for communications wire in all system applications.

The WCI is available in three configurations:

- Universal Model (most common) - installs the same as a wired zone sensor in indoor applications and suitable for plenum use.
- Outdoor Model - housed in an enclosure suitable for outdoor environments. It is usually used on equipment above the roof deck.
- Flush Mount Model - used on fan coils, blower coils, and unit ventilators and suitable for plenum use.

Air-Fi® Wireless Communications Sensor (WCS)

The Air-Fi® Wireless Communications Sensor (WCS) is compatible with any Trane controller that uses a WCI. The WCS provides the same functions as many currently available Trane wired sensors. No further software or hardware is necessary for site evaluation, installation, or maintenance. Space temperature is standard on all models. (A service tool cannot be connected to a Trane wireless sensor.)

Six WCS models are available:

- WCS-SB: Base model, has no exposed display or user interface
- WCS-SD: Digital display
- WCS-SCO₂: CO₂ with occupancy
- WCS-SO: Occupancy
- WCS-SB/R: Refrigeration and freezer monitoring sensor
- WCS-SH: 2% relative humidity sensor module, can be field installed inside either the WCS-SD, WCS-SB, WCS-SO, WCS-SCO₂, WCS-SB/R

In most applications, one WCS sensor will be used per WCI acting as a router. However, up to 6 WCS sensors can be associated to a single equipment controller or BCI/BCI2.

See [“Wireless Sensor Setup,” p. 88](#) for details on how to set this up.

Compatibility with Previous Generation Wireless Zone Products

Our previous line of wireless zone sensors (WZS, WTS, and WDS) are not compatible with the Air-Fi Wireless Communications Interface (WCI).

The new Air-Fi Wireless Communications Sensor (WCS) are compatible with old WCIs that have updated firmware.

WCS-SO and WCS-SCO₂ require minimum unit controller firmware as described in [“Firmware Requirements for Devices on an Air-Fi® Network,” p. 11](#).

Wired Zone Sensors

Wired zone sensors can be used with Air-Fi wireless systems.

Devices Supported by Air-Fi® Wireless Systems

- Tracer® SC/SC+ system controller
- Tracer® UC210 programmable controller

- Tracer® UC400 programmable controller
- Tracer® UC600 programmable controller
- BCI-I/BCI2-I: BACnet Communications Interface for IntelliPak™ systems

Notes:

- *While BCI-I/BCI2-I is compatible with WCS-SB and WCS-SD sensors, it does not support WCS-SO or WCS-SCO₂.*
- *BCI/BCI2 does not support WCS-SB/R refrigeration and freezer monitoring sensors.*

- BCI-R/BCI2-R: BACnet Communications Interface for ReliaTel™ systems

Note: *It is not possible to create any points or references on BCI-I/BCI2-I/BCI-R/BCI2-R. See “BCI/BCI2 Point and Reference Limitations,” p. 91 for more information.*

- Tracer® TU service tool
- Symbio™ 210/210e programmable controller
- Symbio™ 400-B/500 programmable controller
- Symbio™ 700 controller
- Symbio™ 800 programmable controller

Maximum Number of Air-Fi® Devices and Networks Allowed

There are limits to the number of devices in an Air-Fi network. Following are some definitions and a table describing the limit of the number of devices in an Air-Fi wireless network. The best practice is to design the network well below these limits to provide room for future expansion as well as getting the most efficient wireless performance.

Notes:

- *The number of WCIs that can be installed at a site is determined by the applicable Tracer SC license, which specifies the total number of controllers.*
- *For instructions on installing a WCI on a Tracer SC, see “WCI Installation,” p. 24.*
- *Always consider leaving room on the network for additional WCIs or WCSs for future expansion.*
- *Generally, about 20 WCIs on a network is the optimum number to achieve an adequately dense mesh network for multiple communication paths as well as the fastest communication speed with minimum hops.*

Terms:

- **Router**— A WCI wired to a UC controller
- **Repeater**— A WCI that is stand alone. Its only job is to pass on information received from other WCI routers and sensors near it. It is set up with the same Group and Network number as the rest of the network, but it is not wired to a UC controller.
- **Coordinator**— A WCI coordinator establishes the Zigbee® mesh network with surrounding WCI routers. Most of the time this will be the WCI that is wired to the Tracer SC+. However, there are instances where the network is formed without the Tracer SC+. In this case the Coordinator is wired to a UC controller.
- **Devices**— WCI Routers, WCI Coordinators, WCI Repeaters, and WCS Sensors
- **WCS**— Wireless Communicating Sensor (WCS-SB, WCS-SD, WCS-SO, WCS-SB/R, and WCS-SCO₂)
- **SC**—Can be either Tracer SC or SC+

¹ ZigBee is a registered trademark of the ZigBee Alliance.

Table 1. Maximum Air-Fi networks and devices allowed

Max	Equipment	Usage Level	Notes
6	WCS	Per unit controller	A total of six (6) Air-Fi sensors can be associated to a unit controller in any combination (WCS-SB, WCS-SD, WCS-SO, WCS-SB/R, and WCS-SCO ₂).
6	WCS	Per Air-Fi wireless network when associated directly to the Tracer SC+.	A total of six (6) Air-Fi wireless sensors can be directly associated to the SC+ in any combination (WCS-SB, WCS-SD, WCS-SO, WCS-SB/R, and WCS-SCO ₂). Sensors associated directly to the SC+ counts against the Devices maximum of 61.
8	Networks	Per Tracer SC	App and/or Base
8	Coordinator WCI	Per Tracer SC	1 Tracer SC coordinator WCI per network.
30	UC/Symbio™ controllers	Per network	30 is the maximum limit, 20 is recommended.
31	WCIs	Per network	1 Tracer SC coordinator WCI + up to 30 UC router WCIs + WCI Repeater(s).
48	WCS	Per Tracer SC+	Each SC+ Air-Fi Wireless network can have up to 6 sensors directly associated. An SC+ would have to have 8 wireless networks in order to have 48 sensors associated (6 sensors per network x 8 networks = 48). Sensors associated directly to the SC+ count against the Devices maximum of 61.
61	Devices	Per network ^(a) / ^(b)	1 Tracer SC coordinator WCI + up to 30 UC router WCIs + WCSs + WCI Repeater(s).
120	UC/Symbio controllers	Per Tracer SC ^(c)	Applies to both App and Base SC(s).
240	UC/Symbio controllers	Per App SC plus Base SC(s)	See note ^(d) below for examples.

^(a) A WCI on a single UC/Symbio controller may have up to 6 WCS sensors associated. Count each WCS sensor as part of the device total.

^(b) Example 1: 30 UCs each with 1 WCS sensor associated (30 UCs + 30 sensors + 1 coordinator = 61 devices). Example 2: 20 UCs each with 2 WCS sensors associated (20 UCs + 40 WCS + 1 coordinator = 61 devices). Example 3: 8 UCs each with 6 WCS sensors associated (8 UCs + 48 WCS + 1 coordinator = 57 devices).

^(c) This would require a minimum of four (4) networks with 30 unit controllers on each network.

^(d) Example 1: 120 UC controllers on App SC + 120 UC controllers on Base SC. Example 2: 120 UC controllers on App SC + 60 UC controllers on Base SC1 + 60 UC Controllers on Base SC2. Example 3: 60 UC controllers on App SC + 60 UC controllers on Base SC1 + 60 UC controllers on Base SC2 + 60 UC controllers on Base SC3. Example 4: 0 UC controllers on App SC + 120 UC controllers on Base SC1 + 120 UC controllers on Base SC2.

Automatic Network Formation and Sensor Association

A WCI that is connected to a Tracer SC+ is auto-assigned as the network coordinator. The coordinator WCI allows all WCIs and WCSs having matching addresses to automatically join the network. (For more details about the process of network establishment, see [“Establishing an Air-Fi® Network,” p. 60.](#)

If no Tracer SC+ is present, a centrally located WCI connected to a programmable or unit controller or a BCI/BCI2 must be designated as the coordinator. You can designate a WCI to be a coordinator either manually on the WCI or by using Tracer TU. See [“Establishing the Network Prior to Tracer SC+ Installation or Without Tracer SC+ Installation,” p. 63.](#) This scenario includes the application of Air-Fi Wireless sensors with BACnet MS/TP and BACnet/IP (hardwired or Wi-Fi).

After the network is formed, WCSs automatically associate with their designated controllers.

Notes:

- When a WCS is first powered up, it **joins** the network using any WCI within range including the coordinator, and repeaters. The WCI becomes the **parent** for that WCS. As long as there is adequate signal level the WCS will stay with this parent WCI indefinitely. The parent WCI passes any WCS messages over the network to the associated unit controller.
- The network must be open for a WCS to join the network, but does not need to be open for the WCS to be manually assigned to a controller.

Network Security

Air-Fi® Wireless is secured using Advanced Encryption Standard AES-128 (FIPS Pub 197) and HMAC (FIPS Pub 198). The Trane WCI operating as a Trust Center will create a randomly generated 128-bit

network security key for each ZigBee® network. This network security key is required to decrypt communications from the network. In order to join the secured Air-Fi network, the network must first be opened to allow devices to join. To open the network, a technician must plug into a controller on the network from inside a building. This adds another level of security. A device requesting to join the network is given a transport key which must be decrypted by the joining device before it can communicate on the Air-Fi network. The Air-Fi network will automatically close or prevent new devices from joining the network one hour after it was opened.

Air-Fi® Device Part Numbers

The following table lists the Air-Fi® devices with their part numbers and indicates application conditions and availability.

Table 2. Device application, availability, and part numbers

Air-Fi® device	Application	Availability	Part number	BAYSENS	Global part
Wireless communications interface (WCI)	Indoor	Field installed or service	X13790901030	BAYWCII189A	MOD02969
	Outdoor		X13790941030	BAYWCII187A	MOD02971
	Indoor—BAA ^(a)		X13790963030	N/A	MOD03069
	Outdoor—BAA		X13790964030	N/A	MOD03070
	Indoor flush	Service part only	X13790902030	N/A	MOD02970
	Indoor	Factory only	X13790903030	BAYWCII188A	N/A
	Indoor flush		X13790904030	N/A	N/A
Wireless communications sensor—Digital display (WCS-SD)	Universal ^(b)	Field, factory, or service	X13790955010	N/A	SEN02362
	FC BC UV ^(c) and RTU WSHP offerings are factory or service only (not field applied)		X13790955040	N/A	SEN02394
	RTU WSHP ^(d)		X13790955050	BAYSENS202A	SEN02263
	Universal—BAA ^(a)		X13790968010	BAYSENS212A	SEN02265
Wireless communications sensor—Base model (WCS-SB)	Universal		X13790956010	BAYSENS203A	SEN02264
	Universal—BAA ^(a)		X13790969010	BAYSENS213A	SEN02266
Wireless communications sensor accessory—2% relative humidity sensor module (WCS-SH)			X13790973030	BAYSENS230A	SEN02638
Wireless communications sensor— with Occupancy sensor (WCS-SO)	Universal—BAA ^(a)		X13790986001	BAYSENS154A	SEN2502
Wireless communications sensor— with CO ₂ and Occupancy sensors (WCS-SO/SCO ₂)	Universal—BAA ^(a)		X13790987001	BAYCO2K200A	SEN2503
Wireless communications sensor - Base model with external Refrigeration input (WCS-SB/R)	Universal—BAA ^(a)		X13791004001	N/A	SEN02773

^(a) BAA (Buy American Act)

^(b) 1 setpoint, timed override, */**

^(c) 1 setpoint, all Fan options, */**

^(d) 2 setpoints, 2 Fan options (On-Auto), all System options (Off, Auto, Cool, Heat, Emergency Heat)

Firmware Requirements for Devices on an Air-Fi® Network

The following table lists the minimum firmware levels required to allow devices to participate on an Air-Fi network:

² ZigBee is a registered trademark of the ZigBee Alliance.



Overview

Table 3. Minimum firmware level required for devices on an Air-Fi network

Device	One or no WCSs	Multiple WCS-SB, or -SD and/ or an RH sensor module (WCS-SH)	WCS-SO/SCO ₂	WCS-SB/R
Tracer SC	V3.6.xxx	N/A	N/A	N/A
UC210	All versions	V2.00.xxx.mod	V3.0	V3.0
UC400	V6.00.xxx.mod	V8.00.xxx.mod	V9.0	V9.0
UC600	V4.00.xxx.mod	V5.00.xxx.mod	V6.0	V6.0
BCI-I	V25.00.xxx.mod	V28.00.xxx.mod	Not supported ^(a)	Not supported
BCI-R	V5.02.xxx.mod	V6.00.xxx.mod	V7.0	Not supported
RTRM	V12 or higher (requires physical board replacement)	N/A	N/A	N/A
Tracer TU	V8.2	V8.6	V9.3	V9.3
TU Adapter	V1.00.xxx.mod	N/A	N/A	N/A
WCI	V1.00.000.mod	V2.00.000.mod	V2.01.004.mod	V2.01.004.mod
Tracer SC+	V5.1	V5.1	V5.1	V5.1
BCI2-I	All versions	All versions	Not supported ^(a)	Not supported
BCI2-R	All versions	All versions	All versions	Not supported
BCI2-C	N/A	N/A	N/A	N/A
Symbio™ 210/210e	All versions	All versions	All versions	All versions
Symbio™ 400-B/500	All versions	All versions	All versions	All versions
Symbio™ 700	All versions	All versions	All versions	All versions
Symbio™ 800	All versions	All versions	All versions	All versions

^(a) The WCS-SO/SCO₂ sensor can be installed in another controller in the building and referenced by the BCI-I/BCI2-I.

WCI Dimensions

The following figure shows front, side, and bottom views of a WCI with dimensions.

Figure 1. Three views of WCI with dimensions

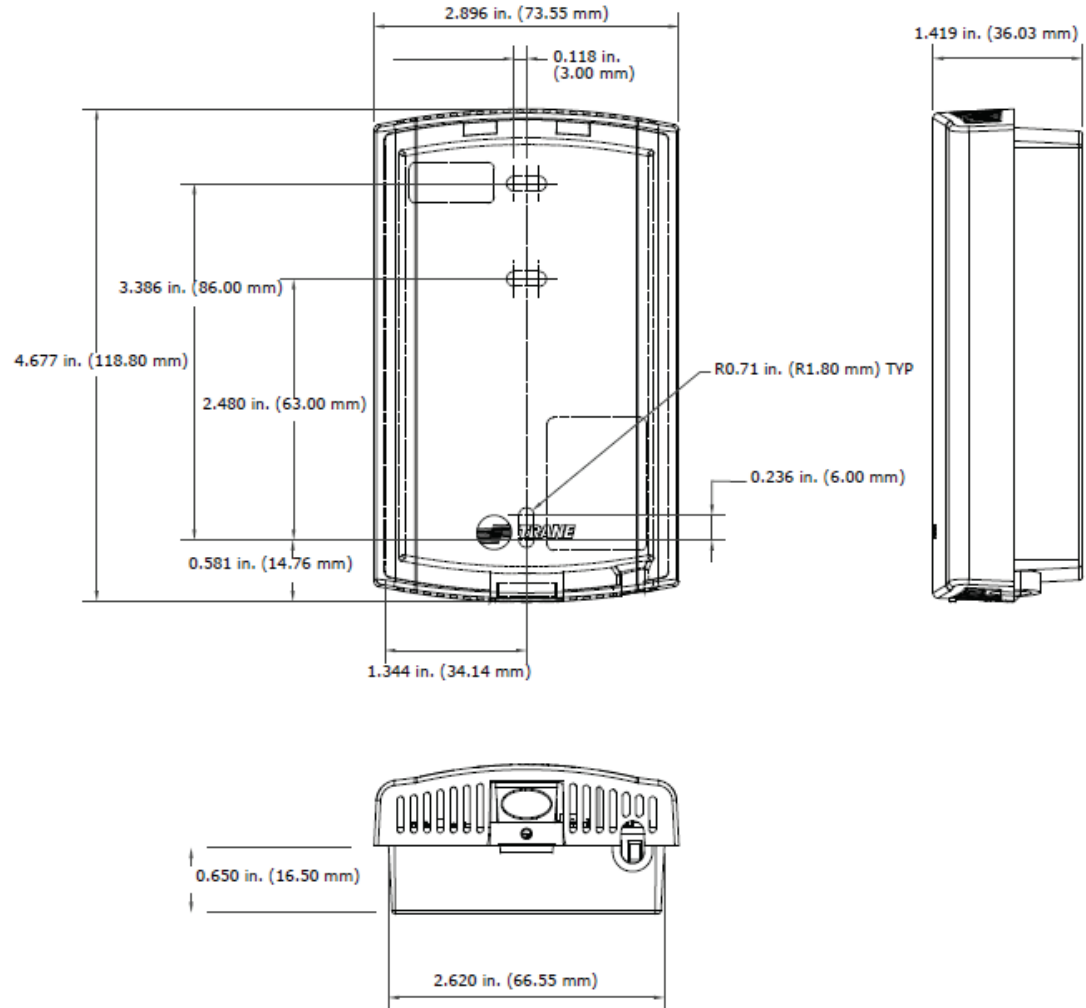

WCS-SB/SD Dimensions

The dimensions are the same for all WCS-SB/SD models. The following illustration shows three views of a SD (display model) which contains an LCD display and a keypad.

Figure 2. Three views of a WCS with dimensions

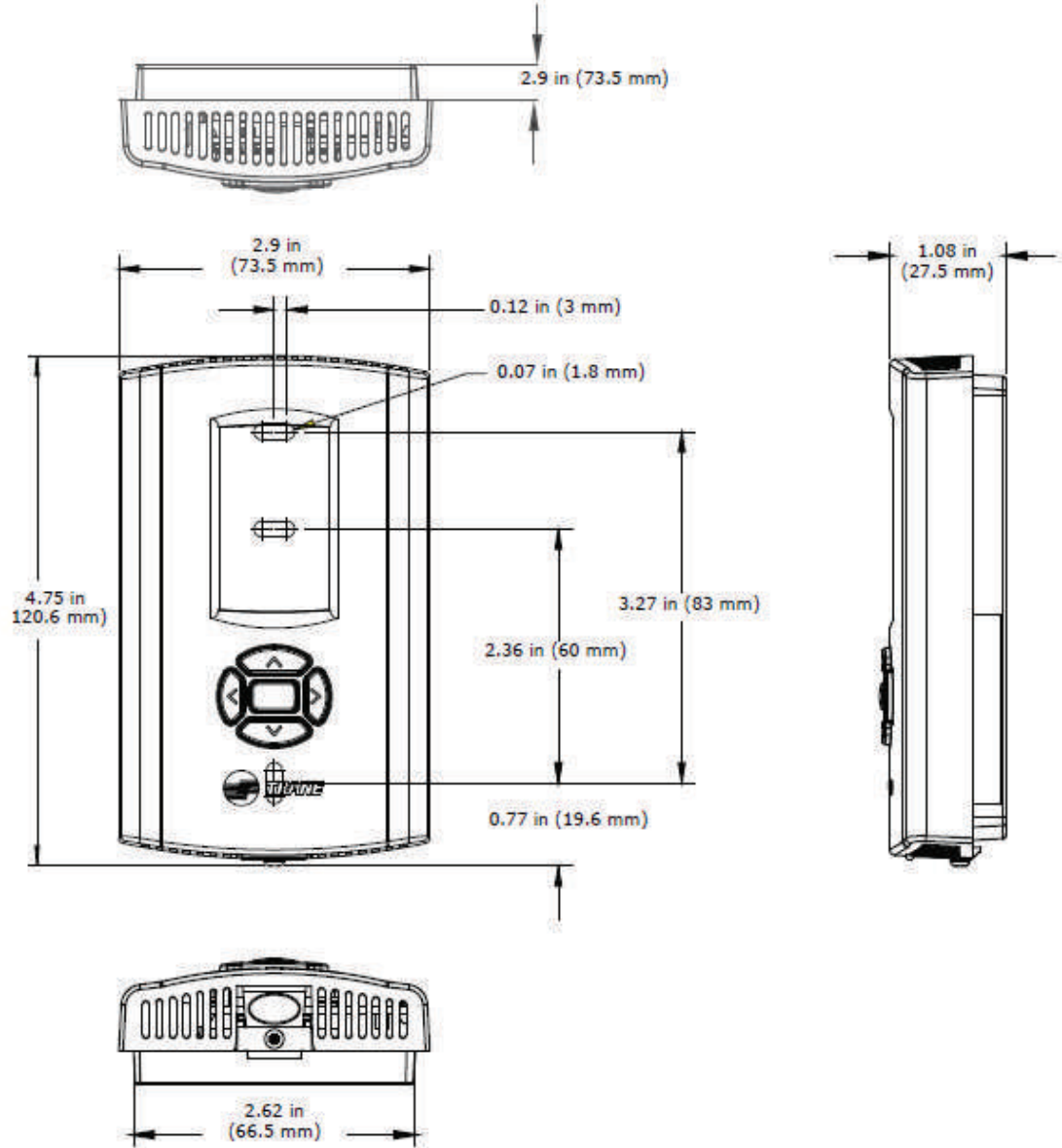

WCS-SO/SCO₂ Dimensions (WCS-SB/R Similar)

The WCS-SO/SCO₂ and WCS-SB/R dimensions are almost the same as the other WCS models, except for total depth.

Figure 3. Three views of an WCS-SO/SCO₂ sensor with dimensions

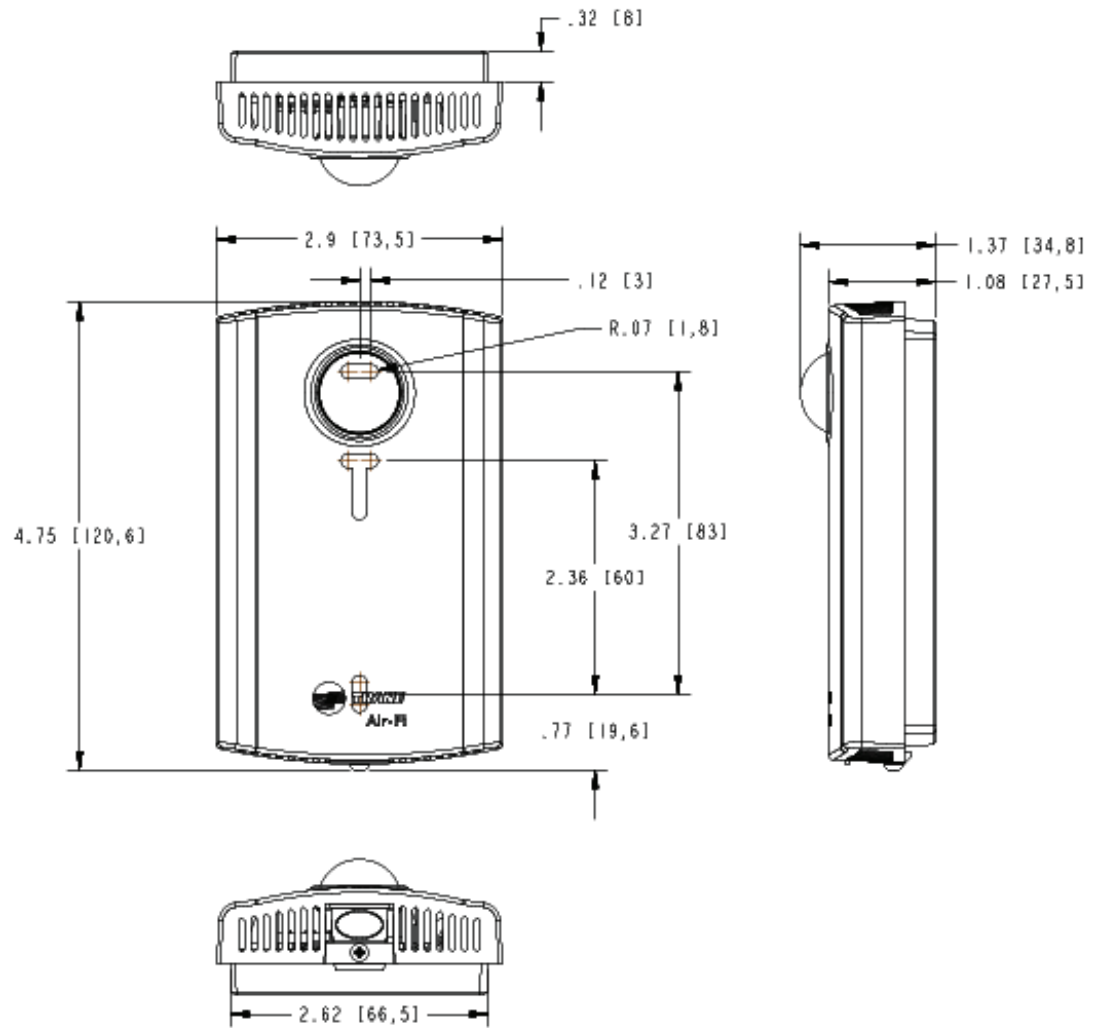



Overview

Specifications

Table 4. WCI and WCS specifications

General Specifications	
Operating Temperature	WCI -40 to 158 degrees °F (-40 to 70 degrees °C) WCS-SB, SD, SO, SCO ₂ and SB/R internal sensor 32 to 122 °F (0 to 50 degrees °C) WCS-SB/R remote sensor -58 to 122 degrees °F (-50 to 50 degrees °C)
Storage Temperature	-40 to 185° F (-40 to 85° C)
Storage and Operating Humidity Range	5% to 95% relative humidity (RH), non-condensing
Housing Material	Polycarbonate/ABS (suitable for plenum mounting), UV protected, UL 94: 5 VA flammability rating. Outdoor WCI unit is Acrylonitrile -Styrene- Acrylate (ASA) resin with HB flame rating. Note: These ratings are for the indoor WCI and sensor models. Only WCI Indoor models are plenum rated.
Range ^(a)	Open range: 2,500 ft (762 m) with packet error rate of 2%. Indoor: Typical range is 200 ft (61 m); actual range is dependent on the environment. See BAS-SVX55* for more detail.
Output Power	100 mW
Radio Frequency	2.4 GHz (IEEE Std 802.15.4-2003 compliant) (2405–2480 MHz, 5 MHz spacing)
Radio Channels	16
FCC ID#	W7Z-ZICM357SP2
IC ID#	8254A-ZICM357SP-1
Wireless Communications Interface (WCI) Specifications	
Voltage	24 Vac/Vdc nominal ±10%. If using 24 Vdc, polarity must be maintained.
Power Consumption	<1.0 VA
Indoor Mounting	Fits a standard 2 in. by 4 in. junction box (vertical mount only). Mounting holes are spaced 3.2 in. (83 mm) apart on vertical center line. Includes mounting screws for junction box or wall anchors for sheet-rock walls. Overall dimensions: 2.9 in. (74 mm) by 4.7 in. (119 mm). Suitable for plenum use.
Outdoor Mounting	Position enclosure in desired flat mounting location and mount using four (4) #8 sheet metal screws with the conduit connection pointing down. If not mounted to the HVAC equipment exterior wall, the conduit connection on the bottom of the enclosure is also available. Please note that the supplied plug must be installed into the unused conduit connection. Overall dimensions: 3.9 in. (98 mm) by 6.4 in. (163 mm) by 1.7 in. (42 mm).
Wireless Protocol	ANSI/ASHRAE Standard 135-2016 (BACnet® / Zigbee®) BACnet® is a registered trademark of American Society of Heating, Refrigerating and Air-Conditioning Engineers (ASHRAE) ZigBee® is a registered trademark of the ZigBee Alliance
Wireless Communications Sensor (WCS) General Specifications	
Accuracy	0.5°F for a range of 55 to 85°F (12.8 to 29.4°C)
Resolution	+0.125°F over a range of 60°F to 80°F (15.56°C to 26.67°C)±0.25°F outside this range
Sampling Rate (Temperature)	30 seconds
Setpoint Functional Range	45°F to 95°F (7.22°C to 35°C)
Transmit Trigger	0.2°F change or once every 15 minutes
Sensor Battery (Energizer® L91)	Two (2) AA lithium 1.5 V batteries, 2800 mAh with an expected life of 15 years under typical operating conditions for non-CO ₂ WCS. For WCS-SCO ₂ , expected battery life is 15 years for commercial buildings occupied 10 hours a day, five days per week. For buildings occupied 24 hours a day/seven days a week, the expected battery life is 10 years.
Address Range	001 to 999 for UC controllers, 001 to 996 for Symbio™ controllers.
Maximum Time Between Transmissions	15 minutes
Minimum Time Between Transmissions	10 seconds. Time between transmissions can be shorter during user interaction.

Table 4. WCI and WCS specifications (continued)

Mounting	Fits a standard 2 in. by 4 in. junction box (vertical mount only). Mounting holes are spaced 3.2 in. (83 mm) apart on vertical center line. Includes mounting screws for junction box and wall anchors for sheet-rock walls. Overall dimensions: 2.9 in. (74 mm) by 4.7 in. (119 mm)
WCS-SO Sensor Specifications	
Coverage Patterns	(See the figure "WCS-SO sensor coverage patterns," which follows this table.)
Sampling Rate	Continuous
Occupied Timeout Delay (delay before going unoccupied)	Average 5–10 minutes after last motion is detected (Not adjustable)
Transmit Trigger	After 10 minutes without motion or once every 15 minutes.
Maximum Detection Range	32 feet (10 m)
Life Expectancy	10 years
Operating Temperature	From 32°F to 122°F (0°C to 50°C)
Occupancy Sensor Type	PIR Passive infrared
Storage Temperature	From —40°F to 158°F (-40°C to 70°C)
Humidity Range	20% to 60% RH
Warm-up Time	≤ 1 min @ full spec ≤ 15 min
Housing Material	Polycarbonate/ABS blend (wall)
WCS-SCO₂ Sensor General Specifications	
CO ₂ Range	0 — 10,000 ppm CO ₂
Sampling Rate	Every 5 minutes when sensor sees motion Every 15 minutes when sensor does not see motion
Accuracy at 25°C	±40 ppm CO ₂ + 3% of reading (includes repeatability)
Transmit Trigger	50 ppm change or once every 15 minutes
Pressure Dependence of Output	Built-in pressure sensor eliminates inaccuracy due to altitude
Recommended Calibration Interval	None (auto-calibrated)
Response Resolution	50 ppm change or 15 minute heartbeat
Life Expectancy	10 years
Operating Temperature	From 32°F to 122°F (0°C to 50°C)
Storage Temperature	From —40°F to 158°F (-40°C to 70°C)
Humidity Range	20% to 60% RH
Warm-up Time	≤ 1 min @ full spec ≤ 15 min
Housing Material	Polycarbonate/ABS blend (wall)
CO ₂ Sensor Type	NDIR Non-dispersive infrared
WCS-SB/R Sensor Specification	
Accuracy (internal thermistor) ^(b)	0.5°F for a range of 55 to 85°F (12.8 to 29.4°C)
Resolution (internal thermistor) ^(c)	+0.125°F over a range of 60°F to 80°F (15.56°C to 26.67°C)/+/- 0.25°F outside this range
Input Resolution (external thermistor)	See Table 5, p. 18



Overview

Table 4. WCI and WCS specifications (continued)

Sampling Rate	30 seconds
Life Expectancy	15 years
Operating Temperature	32°F to 122°F (0°C to 50°C) Internal thermistor. -25°F to 122°F (-32°C to 50°C) External thermistor
2% Relative Humidity (RH) Sensor Module	
Accuracy	±1.8% (typical)
Hysteresis	±1% (typical)
Sampling Rate	30 seconds
Response Time	8 seconds
Long-term Drift	<0.5%RH/year
Transmit Trigger	Change of 1% or every 15 minutes
Life Expectancy	15 years

- (a) Range values are estimated transmission distances for satisfactory operation. Actual distance is job specific and must be determined during site evaluation. Placement of the WCI is critical to proper system operation. In most general office space installations, distance is not the limiting factor for proper signal quality. Signal quality is more greatly affected by walls, barriers, and general clutter. Note that sheetrock walls and ceiling tiles offer little restriction to the propagation of the radio signal throughout the building as opposed to concrete or metal barriers. More details information, including wiring schematics, are available at <http://www.trane.com>.
- (b) Accuracy and Resolution for a remote thermistor will depend on the thermistor that is used.
- (c) Accuracy and Resolution for a remote thermistor will depend on the thermistor that is used.

Table 5. WCS-SB/R remote sensor input resolution

Temperature Input Range	Resolution ^(a)
-10°F to 80°F	≤ 0.2°F
-11°F to -30°F and 81°F to 100°F	≤ 0.3°F
-31°F to -40°F and 101°F to 122°F	≤ 0.4°F
-41°F to -58°F	≥ 0.4°F

- (a) Resolution does not include field supplied 10K Type 2 thermistor tolerance.

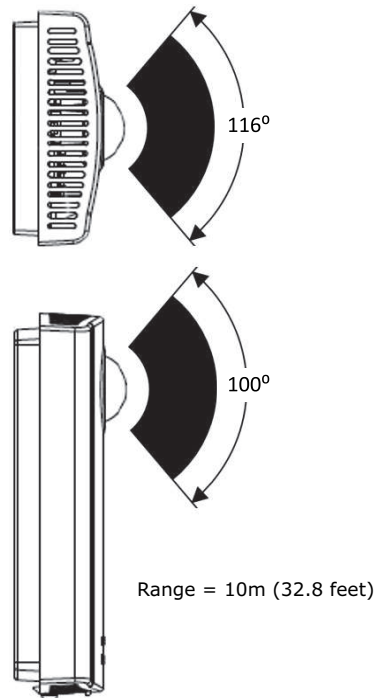
Figure 4. WCS-SO sensor coverage patterns

Table 6. Wireless sensing specifications

Sensor Type	Sampling Rate	Change of Value Trigger/Delay	Heartbeat
Temperature	30 seconds	0.2°F	15 minutes
Relative Humidity	30 seconds	1% RH	
CO ₂	Occupied — 5 minutes Unoccupied — 15 minutes	50 ppm	
Occupancy	Continuous	Unoccupied to Occupied: <ul style="list-style-type: none"> Transmits change of state within 30 seconds. Occupied to Unoccupied: <ul style="list-style-type: none"> 5–10 minutes delay (not adjustable). Sends unoccupied message after 5–10 minutes without motion. 	



Agency Compliance

<p>United States</p>	<p>UL listed: UL 94, 5 VA flammability rating and UL60730-1. Energy Management Equipment FCC CFR47, Sec. 15.247, Digital Modulation Transmission with no SAR (FCC ID: TPF-251701) and (FCC ID: W7Z-ZICM357SP2). This device complies with part 15 of the FCC Rules. Operation is subject to the following two conditions: (1) This device may not cause harmful interference, and (2) this device must accept any interference received, including interference that may cause undesired operation. Changes or modifications not expressly approved by the manufacturer for compliance could void the user's authority to operate the equipment.</p> <p>Note: <i>This equipment has been tested and found to comply with the limits for a Class B digital device, pursuant to part 15 of the FCC Rules. These limits are designed to provide reasonable protection against harmful interference in a residential installation. This equipment generates, uses and can radiate radio frequency energy and, if not installed and used in accordance with the instructions, may cause harmful interference to radio communications. However, there is no guarantee that interference will not occur in a particular installation. If this equipment does cause harmful interference to radio or television reception, which can be determined by turning the equipment off and on, the user is encouraged to try to correct the interference by one or more of the following measures:</i></p> <ul style="list-style-type: none"> • Reorient or relocate the receiving antenna. • Increase the separation between the equipment and receiver. • Connect the equipment into an outlet on a circuit different from that to which the receiver is connected. • Consult the dealer or an experienced radio/TV technician for help. <p>Models X13790901, X13790902, X13790903, X13790904, and X13790963 only (Indoor mounting enclosures) - these units are intended to be installed in accordance with the manufacturer's installation instructions, the National Electrical Code or Canadian Electrical Code, Part 1, and in a manner acceptable to the local authority having jurisdiction. Sensor is Listed for installation in air handling spaces as referenced in the Standard for the Installation of Air Conditioning and Ventilating Systems, NFPA 90A, and installation in plenums as referenced in the International Mechanical Code.</p>
<p>Canada</p>	<p>CSA-C22.2 No. 205-M1983 Signal Equipment Industry Canada (IC: 8254A-ZICM357SP2) This Class B digital apparatus meets all requirements of the Canadian Interference-Causing Equipment Regulations. Cet appareil numérique de la classe B respecte toutes les exigences du Règlement Canadien sur le matériel brouilleur. This device complies with Industry Canada license-exempt RSS standard(s). The operation is permitted for the following two conditions:</p> <ol style="list-style-type: none"> 1. The device may not cause interference. 2. This device must accept any interference, including interference that may cause undesired operation of the device. <p>Le présent appareil est conforme aux CNR d'Industrie Canada applicables aux appareils radio exempts de licence. L'exploitation est autorisée aux deux conditions suivantes:</p> <ol style="list-style-type: none"> 1. L'appareil ne doit pas produire de brouillage. 2. L'appareil doit accepter tout brouillage radioélectrique subi, même si le brouillage est susceptible d'en compromettre le fonctionnement.
<p>IEEE/radio frequency range</p>	<p>IEEE 802.15.4-2003, IEEE Standard for Information Technology – Telecommunications and information exchange between systems – Local and metropolitan area networks – Specific requirements, Part 15.4: Wireless Medium Access Control (MAC) and Physical Layer (PHY) Specifications for Low Rate Wireless Personal Area Networks (LR-WPANs)</p>



Pre-Installation

Designing an Air-Fi® wireless system with robust performance and reliability is relatively easy. However, the design of a wireless network has a direct impact on performance and reliability. For example, performance can be improved by locating the coordinator near the center of the network. Reliability can be enhanced by avoiding wireless signal obstructions.

Note: Always check for pre-existing Air-Fi networks using Tracer TU and the Wireless Adapter. If a network already exists you won't be allowed to create another network using the same address.

Location Considerations

For most installations, barriers limit proper radio signal quality more than distance. To provide the best signal quality between wireless devices and to reduce the number of WCIs needed for an application, mount WCIs and WCSs in direct, unobstructed, line-of-sight paths. Where this is not possible, try to minimize the number of barriers between a WCI and a WCS or coordinator. In general, sheetrock (drywall) walls and ceiling tiles offer little range reduction to the transmission of the radio signal throughout the building. Do not design networks to span more than one floor.

For more detailed information about WCI placement, see the *Air-Fi® Network Design Installation, Operation, and Maintenance manual* (BAS-SVX55*-EN).

WCI Positioning

It makes no difference whether the WCI is positioned horizontally or vertically. It will work in any position. However it is good to know that the antenna is located within the top 1" of the WCI. The antenna radiates in all directions, generally in the shape of a sphere. The position of the WCI, either horizontal or vertical, does not change the radiation pattern. However, the surface where the WCI is mounted can change the radiation pattern. If mounted to a sheet metal box like on a VAV, the sheet metal will reflect much of the radiated signal, in effect blocking the signal from going to the other side of the VAV box. Once the radio signal leaves the antenna it bounces around off hard surfaces in all directions which tends to alleviate some of the blocking effects of the sheet metal box. Most of the time this blocking effect will not be a concern because the bouncing radio signals tend to fill in the entire area. However, in cases where too much signal level is blocked by a sheet metal box or object, and there is not enough signal bouncing back, it may be necessary to reposition the WCI or insure at least the top 1 inch of the WCI is cleared of any metal objects so the radio signal is free to radiate in the direction it needs to go.

Line of Sight Placement

When mounting WCIs, always be cognizant of where the coordinator and other WCIs are located. You do not need to physically see the coordinator or other WCIs from each WCI, but you should at least be aware of any obstruction between them. Remember that the radio signal will penetrate three drywall walls or one cinder block wall and still have about 200 feet of range, so these obstructions should not cause concern. An obstruction like large duct work, sheet metal boxes, large steel electrical panels, solid concrete walls, or elevator shafts may cause signal degradation. If you encounter these obstructions you can extend the IMC cable and mount the WCI in a better location to create an unobstructed signal path to the coordinator or other WCIs. where multiple networks are used to avoid obstructions.

The IMC and power cable can be extended up to 656 feet using methods described in "[WCI Mounting and Wiring](#)," p. 25.

WCI Maximum Wire Length

The maximum wire length between the WCI and its power / communication source is 656 ft (200 m).

Note: The connector that comes with the WCI is one meter in length.

WCI Installation Locations

Note: To comply with FCC regulations, do not mount this WCI within 20 cm (8 inches) of any other radio device including other WCI or wireless sensors. or other wireless devices.

Unit controller

For a unit controller installation, the most typical WCI mounting location is on the sheet metal enclosure of the unit controller or HVAC equipment housing.

Coordinator location

For optimum network performance and reliability, the coordinator WCI should be centrally located within the network. See the *Air-Fi® Network Design Best Practices Guide (BAS-SVX55)* for more detail.

Repeater location

A WCI acting as a repeater can be installed to route messages between a network and WCIs and WCSs that would otherwise be out of range of the network. When choosing a location for a repeater WCI, consider the availability of a 24 Vac/Vdc power source to meet its power requirement. (See “[Repeater Applications](#),” p. 33 for installation information.)

Table 7. WCI location recommendation for RTU installations

RTU Application	Recommended WCI Location	Notes
RTU/VAV	Factory or field install in RTU return section directly above roof opening	Design radius reduced from 200 ft to 100 ft. Lowest cost, serviceable, and proven reliability due to proximity of VAV boxes.
RTU only	Install WCI below roof deck within 200' of network coordinator WCI	Maintains 200 ft design radius and provides reliable communication, but increases cost. Ensure WCI is in a serviceable location. Use wired sensors if located below top floor.
RTU on grade/ducted (RTU/VAV or RTU only)	Install WCI inside building within 200' of network coordinator WCI	Maintains 200 ft design radius and provides reliable communication, but increases cost. Use wired sensors above first floor.

WCS Installation Locations

Note: To comply with FCC regulations, do not mount this sensor within 20 cm (8 inches) of any other radio device including other WCS sensors or other wireless devices.

When selecting a WCS location, avoid the following:

- Areas of direct sunlight
- Areas in the direct airstream of air diffusers
- Exterior walls and other walls that have a temperature differential between the two sides
- Areas that are close to heat sources such as sunlight, appliances, concealed pipes, chimneys, or other heat-generating equipment
- Drafty areas
- Dead spots behind doors, projection screens, or corners

Note: A corner mount is acceptable with the use of the corner mount bracket for CO₂ and occupancy installations.

- Walls that are subject to high vibration
- Areas with high humidity
- High traffic areas (to reduce accidental damage or tampering)
- Placing the sensor inside metal enclosures

WCS Height Requirements

The recommended maximum mounting height is 54 inches from the bottom of the back plate to the floor. If a parallel approach by a person in a wheelchair is required, reduce the maximum height to 48 inches.

Notes:

- Consult section 4.27.3 of the 2002 ADA (Americans with Disability Act) guideline, and local building codes, for further details regarding wheelchair requirements.
- Sensors with Occupancy and/or CO₂ may need to be mounted higher.

WCS Mounting Surfaces

Using the hardware provided, mount the back plate of the sensor to a flat surface such as sheetrock or plaster, or to an electrical junction box. The sensor must be mounted plumb for accurate temperature control and to ensure proper air movement through the sensor.

- If mounting onto sheetrock or plaster, use the plastic threaded anchors (pre-drilling holes is not usually necessary) and the two M3.5 x 20 mm mounting screws.
- For mounting onto an electrical junction box, use the two 6-32 x 3/4 in. screws.

Design Consideration for BCI-I, BCI-R, BCI2-I, BCI2-R and Symbio 700

A best practice when designing Air-Fi® networks used on BCI-I, BCI-R, BCI2-I, BCI2-R and Symbio™ 700 controllers is to always provide a wired sensor in the unit's return section as a backup in case wireless BACnet communication is lost. The Air-Fi temperature sensor information is mapped to the Symbio 700, ReliaTel or IPak controller like a BAS point. If the WCI coordinator fails and the network goes down, the unit thinks it has lost the local space temperature, so it shuts down in response. Having a wired sensor in the return section for the unit to default to in case the wireless network fails is inexpensive insurance against this type of unit shutdown.

While Air-Fi® Wireless sensors may be applied with BACnet MS/TP and BACnet/IP (both hardwired and Wi-Fi), such applications specifically exclude all forms of BCI, since the BCI communication selections for Air-Fi® and BACnet are mutually exclusive and cannot exist at the same time.

WCI Installation

WCI installation includes addressing, mounting, and wiring. Follow the instructions given in the following sections.

WCI Addressing

This section describes the addressing scheme and procedure for the Air-Fi® Wireless Communications Interface (WCI). WCIs can be ordered either pre-addressed or without addresses. Verify pre-addressed WCI prior to installation.

Note: The default address is 1,1.

The following figure illustrates the addressing scheme used for WCIs. Four networks and two Tracer SC+ controllers are shown, with each Tracer SC+ communicating on two networks. Follow this procedure to set the WCI address for network communication. The table that follows in this subsection provides address setting details.

Important: Addresses must be set on WCIs before applying power to them.

1. Set the left (**GRP**) rotary address switch for each WCI that is in the same Tracer SC+ group to an identical number. (A Tracer SC+ group refers to all of the networks that communicate with the same Tracer SC+.)
2. Set the right (**NET**) rotary address switch for each WCI that is to be on the same network to an identical number. If there are multiple networks in a Tracer SC+ group, each network in that group must have a unique number.

Note: The NET address (ranging from 1–8) must match the wireless link on Tracer SC+.

Figure 5. Addressing example: two groups with two networks

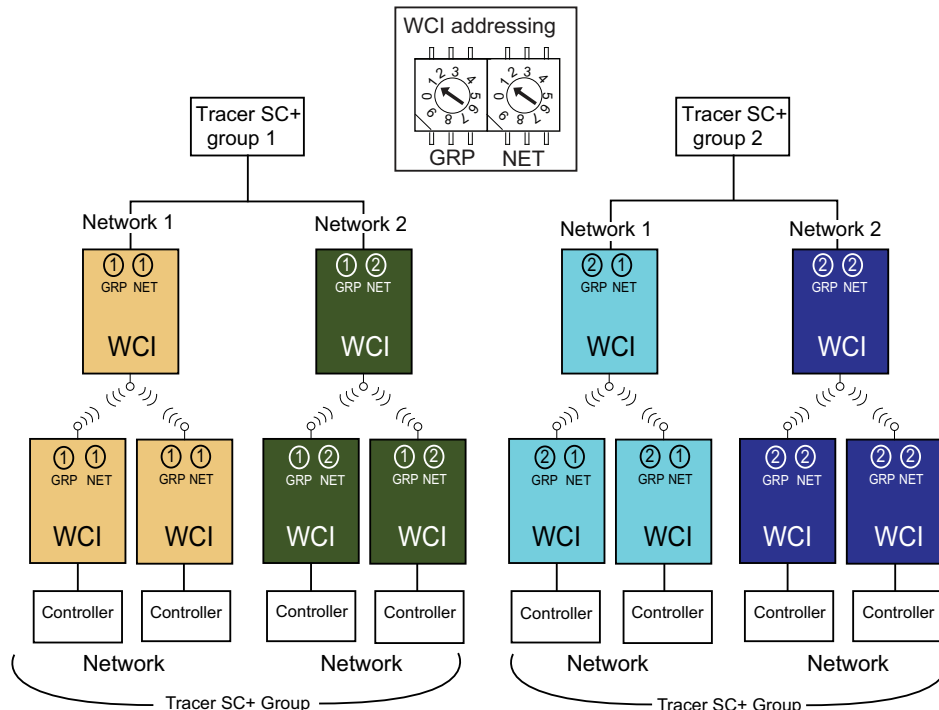

Notes:

- Refer to the Air-Fi® Network Design Installation, Operation, and Maintenance manual (BAS-SVX55*-EN) to see an example of network addressing from a floor plan perspective.
- Controllers can be UC, Symbio™, BCI-I/R or BCI2-I/R.

Table 8. Address settings

Function/Purpose	GRP	NET
Trane BACnet communications	0–8	1–8 ^(a)
Return to default configuration (reset the WCI)	0	0
GRP 9 is reserved for future use when integrating with other BACnet over Zigbee compliant devices. Do not use.	9	N/A
Future use	N/A	9

^(a) Must match the Air-Fi Wireless network number. (See “Tracer SC Addressing” in the *Air-Fi Wireless Network Installation, Operation, and Maintenance manual* (BAS-SVX55*-EN).)

WCI Mounting and Wiring

Mounting and wiring instructions for controller applications and repeater applications are given in this section.

⚠ WARNING

Hazardous Service Procedures!

Failure to follow all precautions in this manual and on the tags, stickers, and labels could result in death or serious injury.

Technicians, in order to protect themselves from potential electrical, mechanical, and chemical hazards, **MUST** follow precautions in this manual and on the tags, stickers, and labels, as well as the following instructions: Unless specified otherwise, disconnect all electrical power including remote disconnect and discharge all energy storing devices such as capacitors before servicing. Follow proper lockout/tagout procedures to ensure the power can not be inadvertently energized. When necessary to work with live electrical components, have a qualified licensed electrician or other individual who has been trained in handling live electrical components perform these tasks.

Important: To comply with FCC and IC regulations, do not mount the WCI within 20 cm (8 inches) of any other radio device.

Controller Applications

1. Remove power from the controller that is to have the WCI wired to it.
2. Remove the WCI cover by firmly pressing the thumb tab at the bottom of the cover and pulling the cover away from the back plate as shown in the following figure.

Note: If present, remove the security screw before removing the cover.

Figure 6. Removing the cover

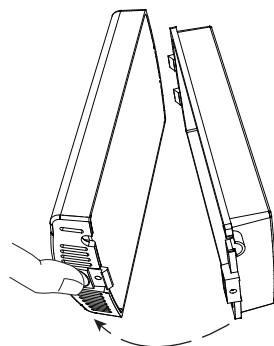

3. Secure the backplate to the mounting surface using appropriate hardware. (M3.5 x 20 mm self-drilling screws are provided.)
4. Attach the 4-conductor screw terminal block on the wiring harness to the receptacle on the WCI as

shown in the following figure.

Figure 7. Connecting wiring harness

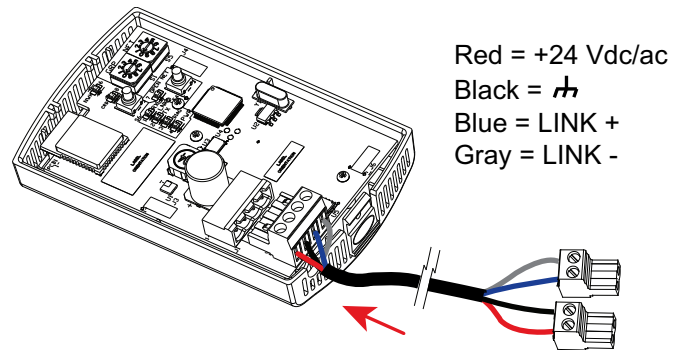

5. Route the wires from the WCI through either:
 - a. The opening in the back plate (part a of the following figure).
 - b. The bottom exit port (part b of the following figure).

Figure 8. Routing the wires through the WCI backplate or the WCI bottom exit port

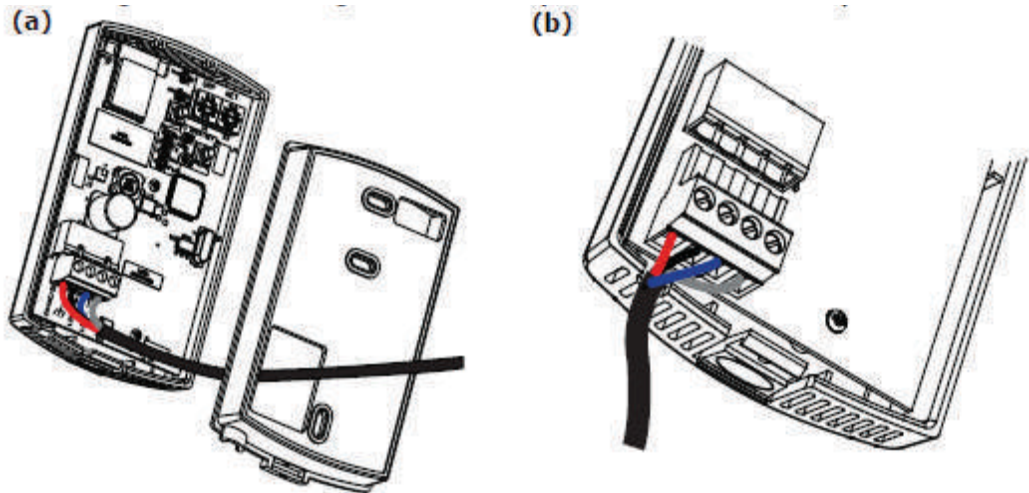

6. Connect the wiring harness according to the illustration that is appropriate for your application.

Notes:

- *If the wiring harness does not provide enough length for a proper mounting location of the WCI, use Trane communication cable as a substitute. Trane “purple wire”, is 2-conductor, 18 AWG stranded, 25pF/ft. cable with braided shielding. The Trane purple cable is required for the communication link, and a separate shielded or unshielded two conductor 18 - 22 AWG cable is required for 24V AC/DC power. (It’s not necessary to use Trane purple wire for the power. It is required only for communication.) Using separate cables for power and communication is desirable to reduce interference, which can cause intermittent communication over long wire runs. The cable length between the WCI and a controller cannot exceed 656 feet (200 m).*

When Trane purple shielded cable is used for communication, the braided shielding wire must be grounded on the UC, BCI-I, PM014, or BCI-R end only. On UC, BCI-I, or PM014 use a chassis ground termination (⌚) on the controller. However, on a BCI-R, BCI2-R, BCI2-I, UC210 factory mount, Symbio 210/210e factory mount or UC400-B you will have to ground the braided shielding wire to the machine chassis, possibly under a board mounting screw head, since the controller has no chassis ground termination available. The WCI end of the cable will have the shielding braid unconnected and taped back.

If shielded cable is used for power, it is optional whether to ground the shielding braid or just tape it back. If you choose to ground the shielding braid, it will be grounded at the controller end at the same point where the Trane purple communication shielding was terminated. The WCI end of the power cable will have the shielding braid unconnected and taped back.

- *Avoid running the communication cable parallel and up against any high voltage wiring or electric motors in the machine or building as this causes noise to be induced into the communication wire and can cause intermittent communication of the WCI. Try to keep the communication cable as far away from high voltage wiring or electric motors as possible. It is acceptable to run the communication cable perpendicular to high voltage wires as this will not induce noise into the communication cable.*
- *When wiring a WCI, always power the WCI from the controller if possible. If it is not possible to power the WCI from the controller, then remote powering of the WCI is permissible. A case where it is permissible to use remote powering might be when trying to re-use an existing 2 conductor cable. In this case the existing cable will be used for communication and the WCI would need to have 24V AC/DC power supplied remotely.*
- *To save on installation labor, we recommend Windy City Wire MegaPack, part number TRNMEGAPAC, for installation of Air-Fi® Wireless Coordinator WCIs (Wireless Communication Interfaces). It includes 18/2 Shielded Low-capacitance Comm (BACnet) cable (052003) + 18/2 Shielded Plenum (power) cable (002320) in a single carton. Minimum cable length is 1000”.*

To wire the WCI to UC, BCI, BCI2, Symbio™ or SC+ follow diagrams on the following pages.

For detailed information, refer to the *BACnet MS/TP Wiring and Link Performance Best Practices and Troubleshooting Guide (BAS-SVX51*-EN)*.

7. Restore power to the controller.

The network is ready to be formed. Refer to “[Establishing an Air-Fi® Network](#),” p. 60.

Important: *The WCI must be wired to the controller prior to power up in order to establish network communication. If you cannot apply power to the WCI and the controller at the same time, apply power to the WCI first by using a remote power source.*

Figure 9. Wiring the WCI to a Tracer SC

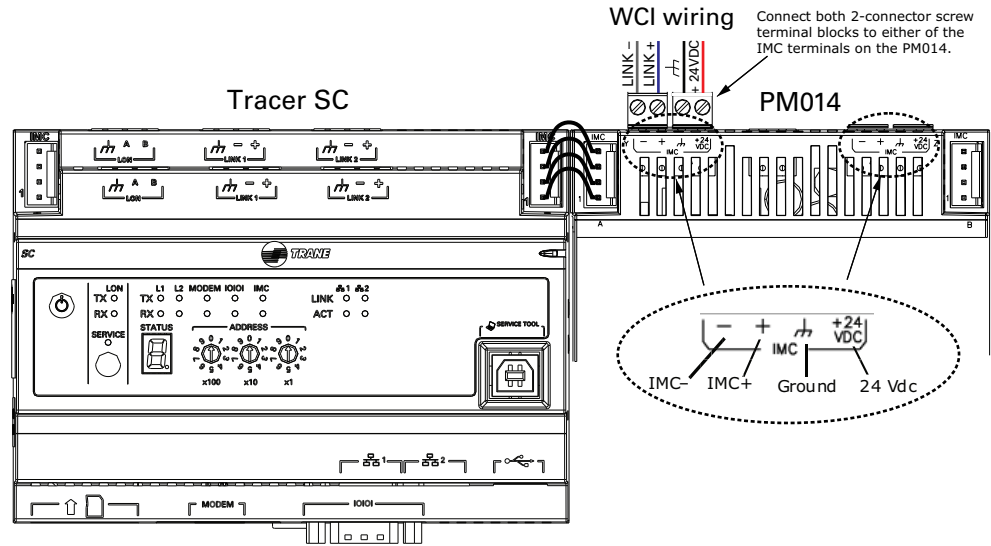

Figure 10. Wiring multiple coordinator WCIs to a Tracer SC

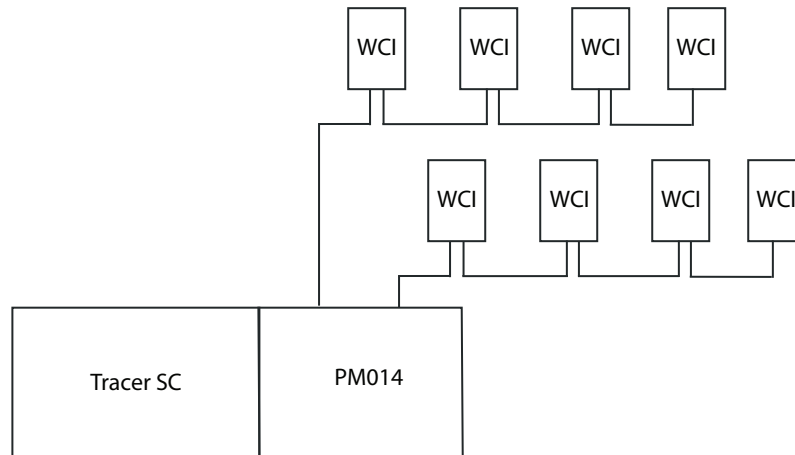

Figure 11. Wiring the WCI to a Tracer SC+ with PM014

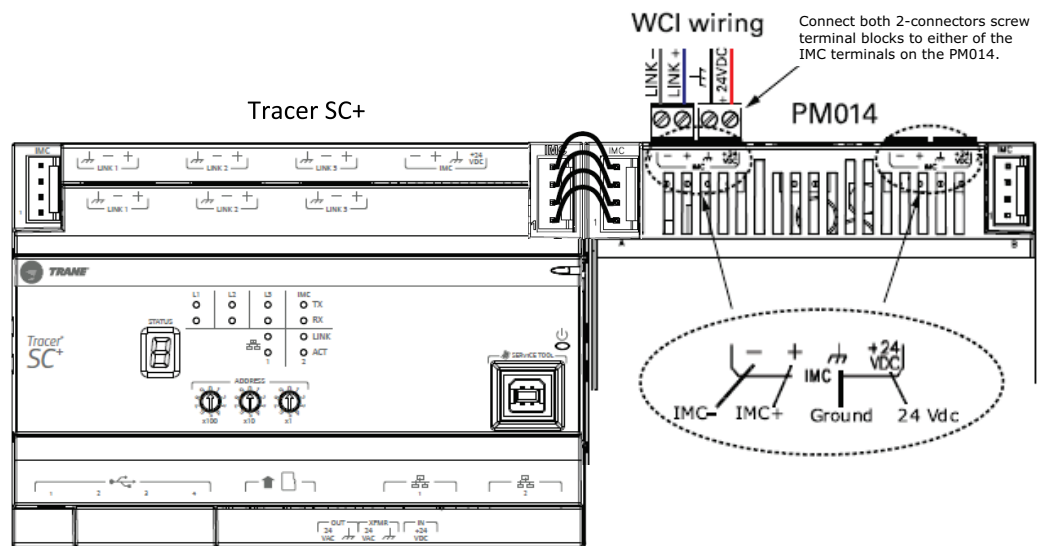

Figure 12. Wiring SC+ WCI coordinators using PM014

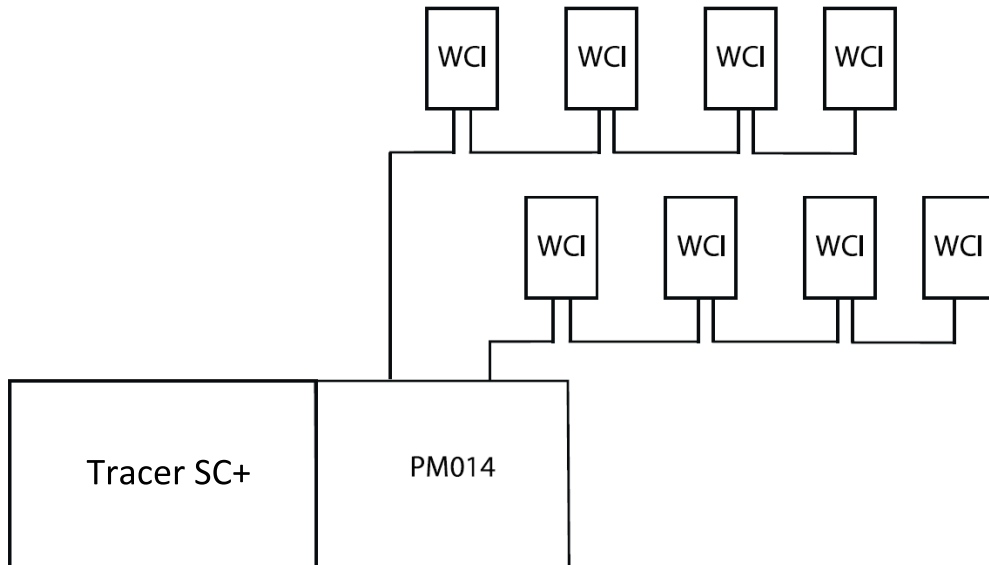

Figure 13. Wiring the WCI coordinator to a Tracer SC+ when IMC power budget allows (wiring a WCI to Symbio™ 800 similar)

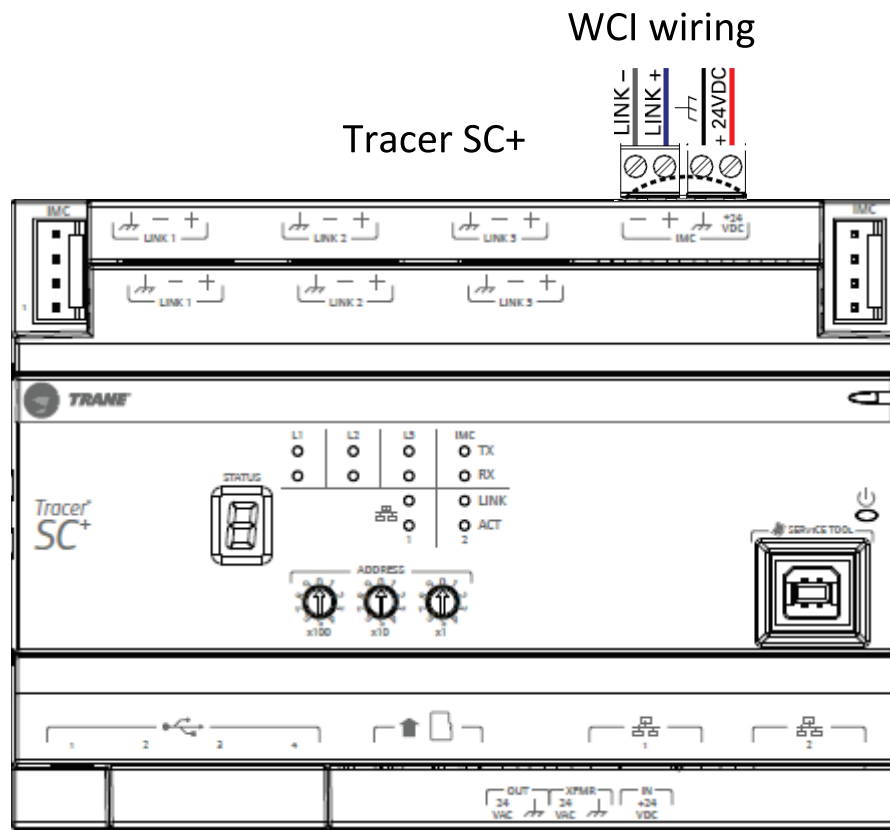
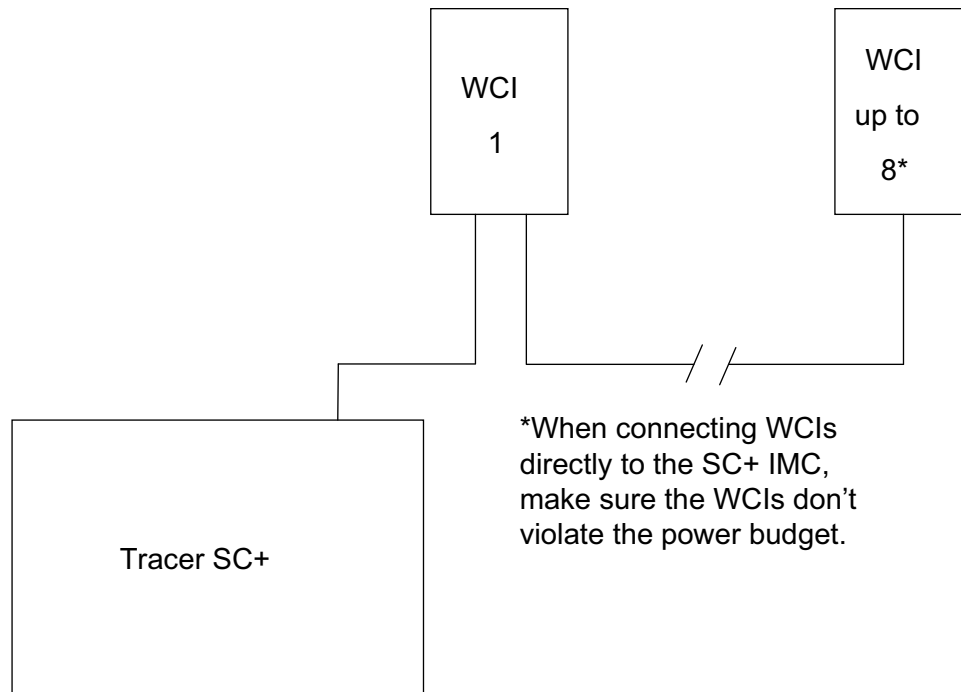

Figure 14. Wiring the WCI coordinator to the SC+ when power budget allows



Notes:

- A maximum of eight coordinator WCIs are allowed to be connected to the Tracer SC and SC + wired as a daisy chain. No “star” type wiring is allowed. See diagrams above.
- Use both IMC terminals on the PM014 for wiring multiple WCIs (see the detail in [Figure 9, p. 28](#)).
- The total combined length of both IMC links must not exceed 656 feet (200 meters).
- Exceeding 656 feet (200 meters) will cause the IMC communication signal to degrade.
- Use Trane purple communication cable (2 conductor, 18 AWG stranded, 25pF/ft. with braided shield) for the communication link.
- Use a separate 2 conductor 18 — 22 AWG stranded, optionally shielded cable for the power.
- On SC, all coordinators should be powered by the PM014. On SC+, coordinators can be powered directly from the SC+ IMC port as long as it stays within the power budget. On SC+, if power budget is exceeded when wiring directly to the SC+, then a PM014 should be used and all coordinators powered from the PM014.
- The braided shielding wires for communication should run continuously from the WCI at the end of the link, all the way back to the PM014 and then be connected to the chassis ground termination on the PM014. At the last WCI on the opposite end of the link, the shielding braid is not connected and is taped back.

Figure 15. Wiring the WCI to a UC210, UC400, UC400-B*, UC600, Symbio™ 210/210e, and Symbio™ 400-B*/500

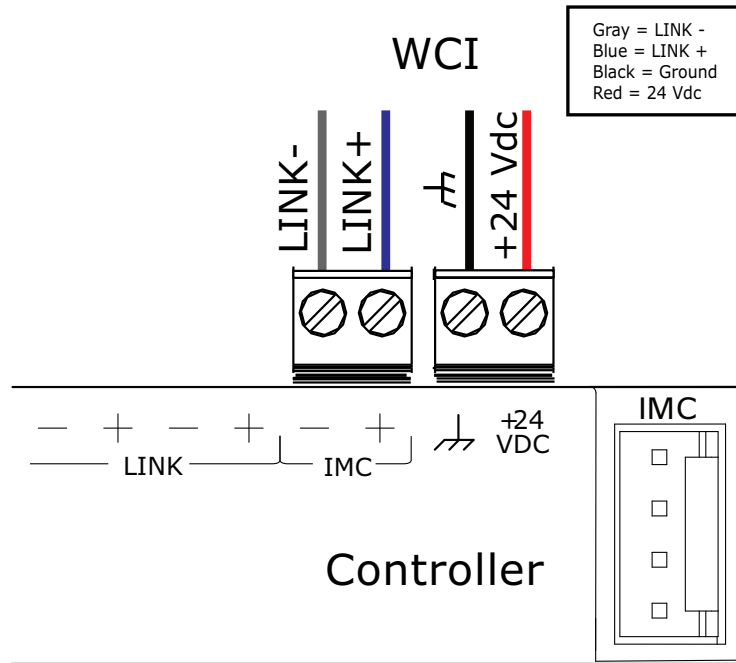

Note: * For UC400-B and Symbio 400-B use J13.

Figure 16. Wiring the WCI to a BCI-I

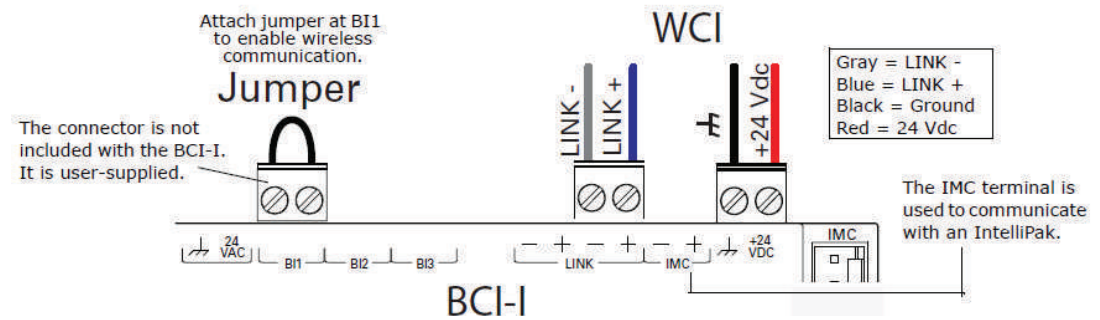

Figure 17. Wiring the WCI to a BCI-R

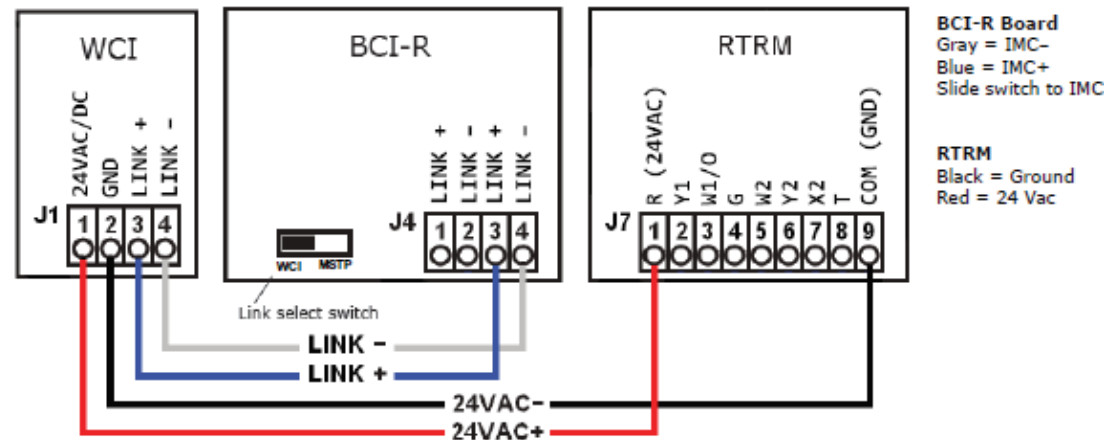

Figure 18. Wiring a WCI to Odyssey™ with Symbio™ 700

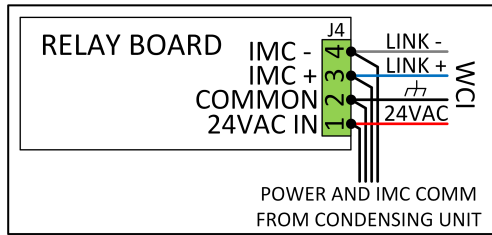

Figure 19. Symbio™ 700 Precedent™/Voyager™ 3

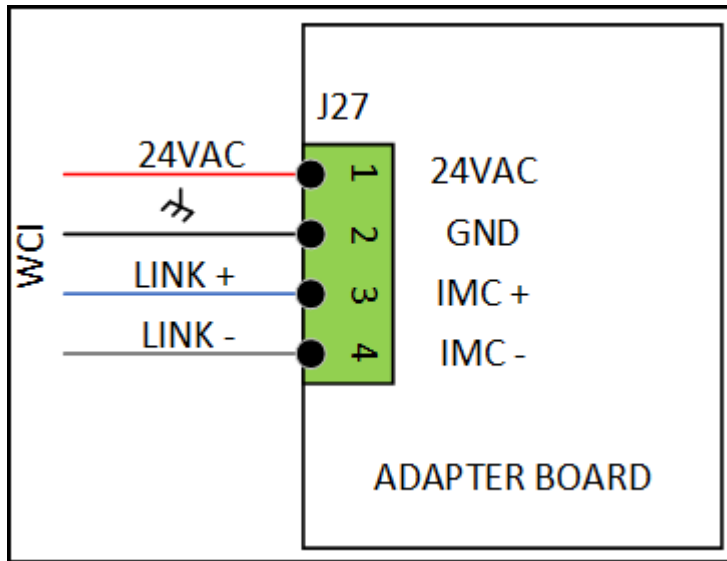

Figure 20. Wiring a WCI to BC12-R

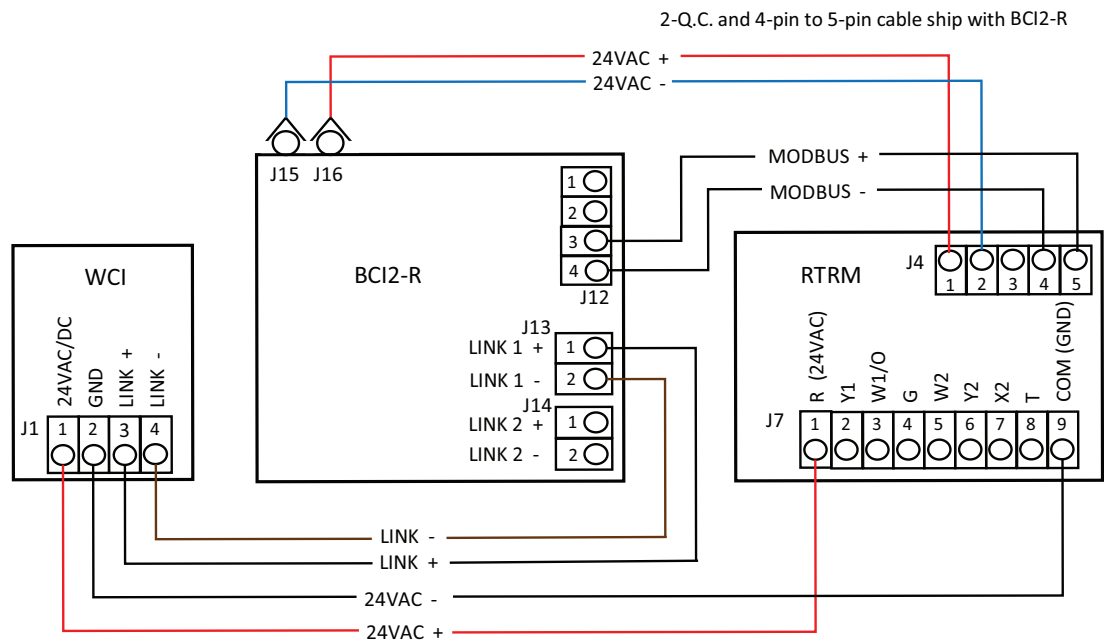
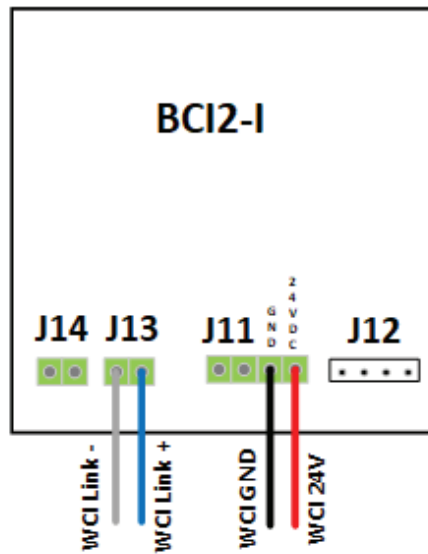

Figure 21. Wiring a WCI to BCI2-I



Repeater Applications

The following procedures describe how to:

- Install a WCI as a repeater.
- Change a WCI from device association to repeater.

For more information about the use of repeaters with Air-Fi Wireless, see *Air-Fi® Network Design Installation, Operation, and Maintenance manual* (BAS-SVX55*-EN).

Installation Procedure

Note: Consult the figures shown in the previous “Controller Applications,” p. 25 subsection as you perform the steps in the following procedure.

1. Remove the WCI cover by firmly pressing the thumb tab at the bottom of the cover and pulling the cover away from the back plate.

Note: If present, remove the security screw before removing the cover.

2. Secure the backplate to the mounting surface using appropriate hardware. (M3.5 x 20 mm self-drilling screws are provided.)
3. Address the unit by setting the GRP and NET rotary dials the same as the rest of the network.
4. Attach the 4-connector screw terminal block on the wiring harness to the receptacle on the WCI.
5. Remove the blue (IMC+) and gray (IMC-) wires from the wiring harness.
6. Connect the red (24 Vdc/Vac) wire and black (ground) wire through the opening in the backplate (a) or the bottom exit port (b) to a 24 V power source (AC or DC). See [Figure 8, p. 26](#).
7. Apply power to the WCI.

Figure 22. Wiring a WCI as a repeater

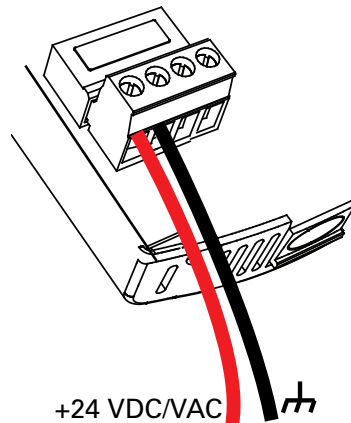

8. You are now ready to add the repeater to an existing network (refer to [“Adding WCIs to an Existing Network Using Tracer TU,”](#) p. 68 or [“Adding WCIs to an Existing Network Using a WCI,”](#) p. 68. To proceed with establishing a new network refer to [“Establishing an Air-Fi® Network,”](#) p. 60 .

Note: *When the repeater is added, its DIAG LED blinks constantly. This behavior is normal.*

Changing a WCI from Device Association to Repeater

If the WCI communication wire was previously connected to a controller, return the WCI to its default configuration as follows:

1. Set its rotary address switch to 0,0 (the WCI must be powered).
2. Observe its LEDs blink On briefly (<1 second). (It takes about 10 seconds for the blink to occur.)

You are now ready to add the repeater to an existing network (refer to [“Adding WCIs to an Existing Network Using Tracer TU,”](#) p. 68 or [“Adding WCIs to an Existing Network Using a WCI,”](#) p. 68. To proceed with establishing a new network (refer to)[“Establishing an Air-Fi® Network,”](#) p. 60 .

Note: *When the repeater is added, its DIAG LED blinks constantly. This behavior is normal.*

WCS-SB/SD Installation

A WCI, in addition to providing wireless communications between controllers, can provide wireless communication to Air-Fi® Wireless Communications Sensors (WCSs). A WCI can receive the signal of a WCS when the WCS has been powered up and addresses have been set up on it. Use the following procedures.

Powering the WCS

Complete the following steps to power up the WCS:

1. Remove the WCS cover by firmly pressing the thumb tab at the bottom of the cover and pulling the cover away from the back plate.
2. Power the sensor by removing the insulation strip from between the two batteries.

Figure 23. Pulling the insulation strip from between batteries

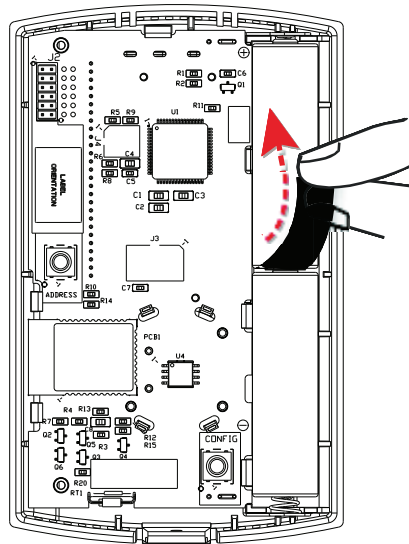

WCS Addressing

Prior to setting addresses on the WCS, you need to know the group and network address (2 digits), the network address (2 digits), and the unit controller address (3 digits).

Notes:

- A Tracer SC group refers to all of the networks that communicate with the same Tracer SC.
- Unit controller addresses above 127 may be used for Air-Fi Wireless systems. (Previously, with hardwired MS/TP communication, no addresses higher than 127 were allowed.)

1. Remove the cover of the sensor.

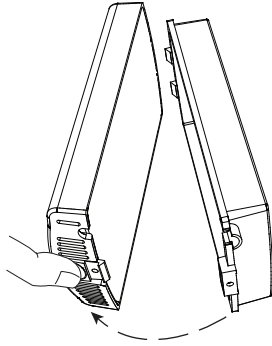
Figure 24. Removing the sensor cover

2. Press and hold the Address button located on the back of the sensor until two numbers appear at the top of the display, with the left number flashing. At the bottom of the display, the letters **g n** appear.

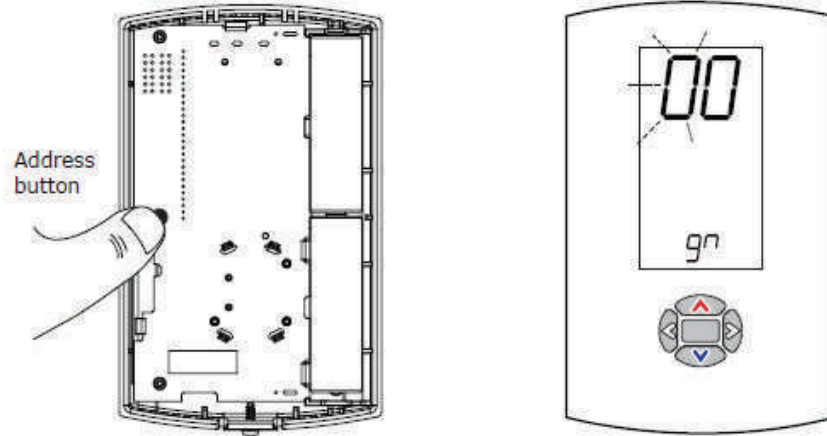
Figure 25. Pressing the address button

The **g** corresponds to the Tracer SC group (GRP) and the **n** corresponds to the network (NET).

Notes:

- Use the up/down arrow buttons to change the value of the number that is flashing.
 - Use the left/right arrow buttons to scroll to the other address settings.
 - If no button is pressed, the display will return to the normal screen after several seconds.
3. Press the up/down arrow buttons on the front of the sensor to set the left number to match the corresponding group (GRP).



4. Press the right arrow button to make the right number flash.

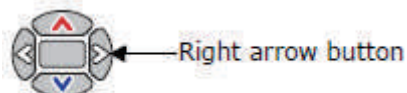

5. Press the up/down arrow buttons to set the right number to match the corresponding network (NET).
6. Press the right arrow button to proceed to the next address setting. Three numbers appear at the top of the display, with the left number flashing. At the bottom of the display, the letters **U C** indicate that the three numbers correspond to the three-digit address of the unit controller.

Figure 26. Setting the UC rotary address

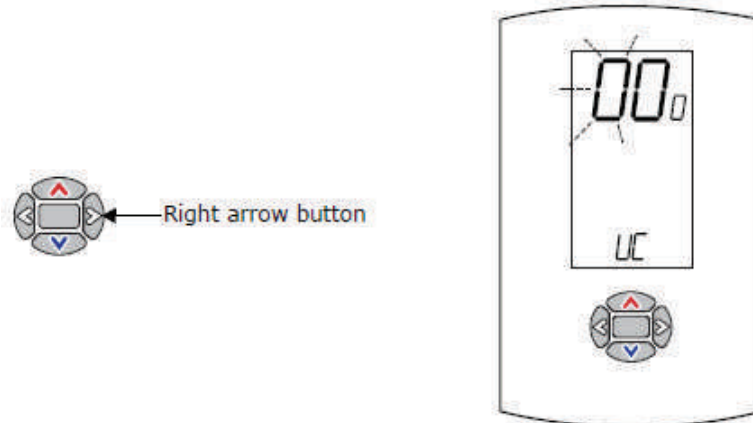

7. Press the up/down arrow buttons to set the flashing number to match the first number of the rotary address setting of the associated unit controller.
8. Press the right arrow button to make the second number flash.
9. Set the second number as for the first. Repeat the same procedure for the third number.
10. If only one WCS is associated with a WCI, proceed to the last step.

If multiple WCSs (maximum of 6) are associated with the same WCI, each WCS must have a unique sensor address. WCS address numbers must be consecutive.

Note: *The total number of associated sensors affects the total number of WCIs that can communicate on the network. Refer to "Maximum Number of Air-Fi® Devices and Networks Allowed," p. 9.*

For multiple WCS installations, press the right arrow button to proceed to the WCS address setting. One number (default is "1") will appear at the top of the display. At the bottom of the display, the letters **S n** indicate that the top number corresponds to a sensor address.

Note: *Additional setup is required in Tracer TU for multiple WCS installations. For details, see "Using the Tracer® TU Service Tool with a Wireless Network," p. 78.*

Figure 27. Setting a unique sensor address

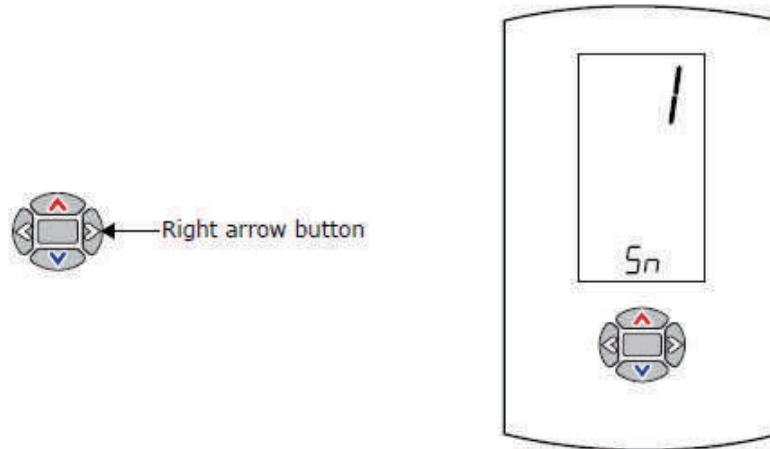

11. Press the up/down arrow button to set a unique sensor address (1 through 6) for the WCS.
12. Addressing is finished. Press the center button to return to the normal display.

Note: To verify addressing, press and hold the Address button until the display changes to addressing mode. Then use the right arrow button to scroll through the settings.

The following figure shows the same Air-Fi Wireless figure shown in “WCI Addressing,” p. 24, but with WCSs added.

Figure 28. Air-Fi addressing example: WCIs and WCSs

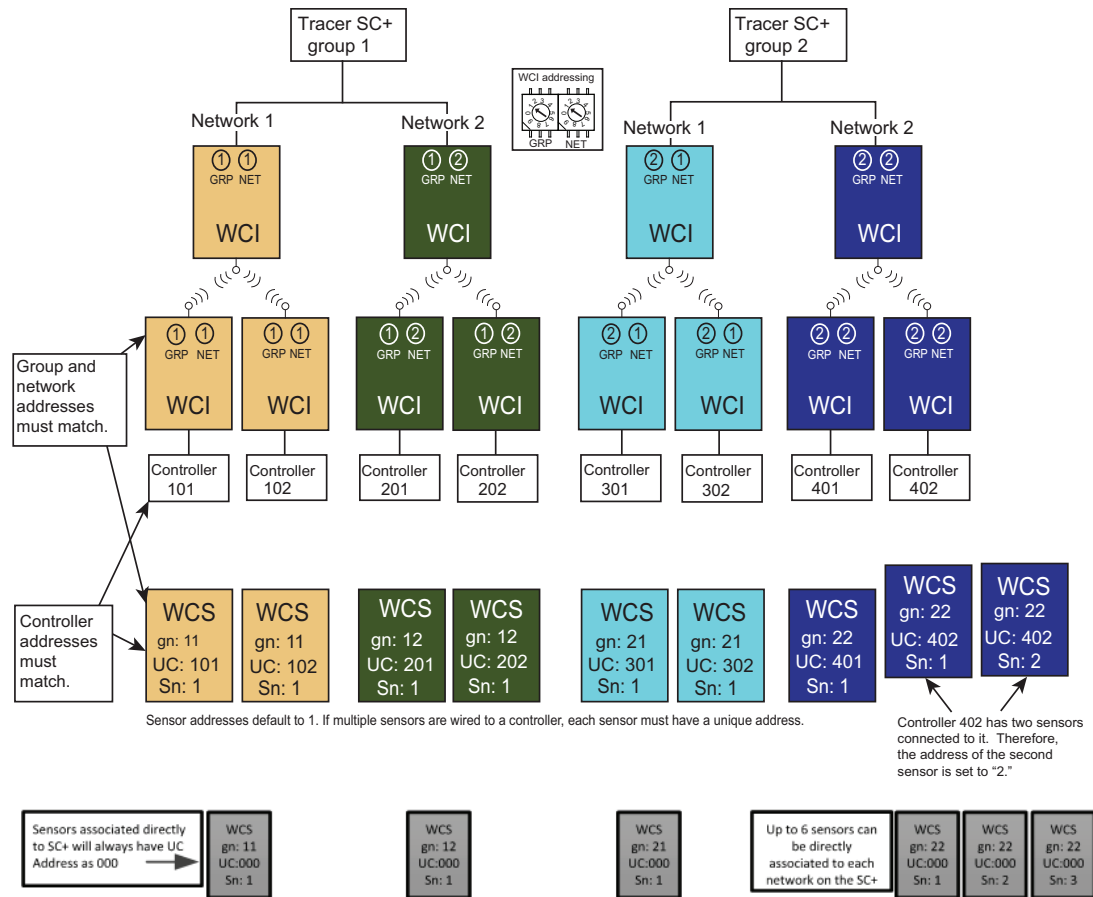

Starting with SC+ v5.10 it is possible to associate WCS sensors directly to the SC+. Sensor configuration and point creation is done using Synchrony.

WCS: Network Joining and Controller Association

After addresses are set, insure the network is open, press the center button twice. You will see rotating segments on the display while the sensor attempts to join the network and associate to the unit controller. If successful, you will see a signal strength icon.

- Error code **E2** will appear on the sensor display until the WCS successfully joins the network. Until network joining is successful, the WCS will repeat its attempt to join every 60 minutes .
- Association between the WCS and the controller will automatically be initiated. The WCS will repeat its attempt to associate every 15 minutes until successful. Error code **E1** will be displayed until association is successful .
- You can press the center button twice at any time to cause the WCS to re-attempt to join the network and to associate with the controller.
- To verify the strength of the network signal quality and of the WCS battery charge, refer to “Testing WCS Signal Quality and Battery Life,” p. 74.

2% Relative Humidity Sensor Module

A 2% relative humidity (RH) sensor module, available as a separate part (X13790973030; model WCS-SH), can be installed on a WCS either before or after the WCS is powered up (see below). If the RH sensor module is installed on the WCS after power-up, the WCS will detect it the next time its backlight turns on. (The backlight turns on whenever a keypad button is pressed.)

Figure 29. RH sensor module (WCS-SH)

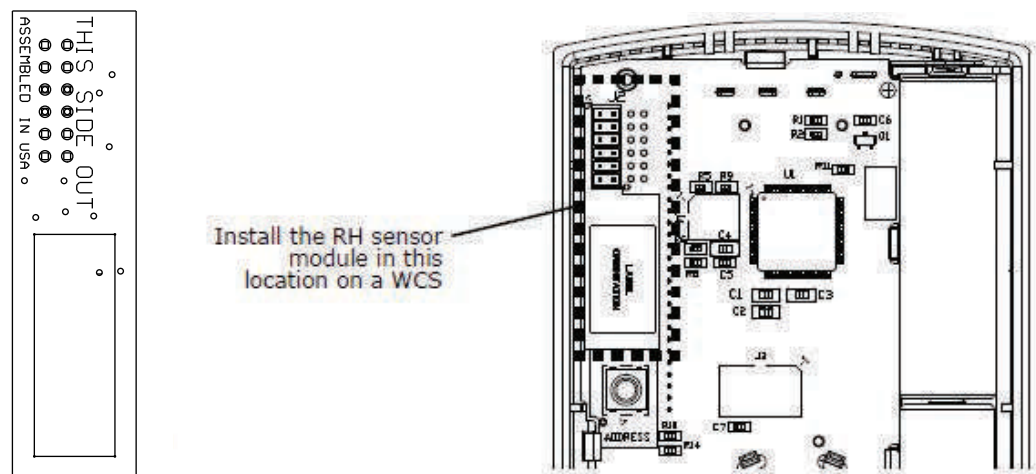

RH Sensor Module

A WCS with an RH sensor module installed on it will display the humidity measurement icon at the bottom center of the display as shown in the following figure. The humidity measurement icon alternates with error codes, if any exist.

Figure 30. Display screen of a WCS with an RH sensor module



WCS : Points and Referencers

If you have added an optional Relative Humidity module or have multiple sensors associated to a single controller, you may need to add points to be able to see these values in TU or SC. See "Referencing Individual Sensors" section for more information.

Mounting the Sensor Back Plate

To mount the sensor back plate:

1. Hold the back plate against the mounting surface and mark the screw locations.
2. Secure the back plate against the mounting surface using included hardware.

The figure shows an example of mounting the back plate of the sensor into sheetrock or plaster.

Figure 31. Mounting the sensor back plate into sheetrock

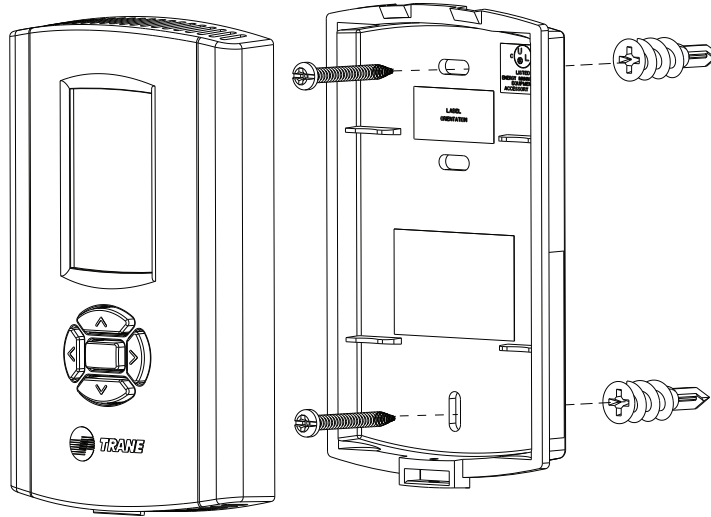

Important: To comply with FCC and IC regulations, do not mount this sensor within 20 cm of any other radio device including other WCS sensors.



WCS–SO/SCO₂ and –SB/R Installation

Note: WCS-SO/SCO₂ and SB/R sensors have limited functionality when used with any BCI. See “BCI/BCI2 Point and Reference Limitations,” p. 91 for more information.

A WCI, in addition to providing wireless communications between controllers, can provide wireless communication to Air-Fi® Wireless Communications Sensors (WCSs). A WCI can receive the signal of a WCS when the WCS has been powered up and addresses have been set up on it. Use the following procedures.

Powering the WCS-SO, -SCO₂, -SB/R Sensor

Complete the following steps to power up the WCS-SO, SCO₂, SB/R sensor:

1. Remove the cover by firmly pressing the thumb tab at the bottom of the cover and pulling the cover away from the back plate.
2. Power the sensor by removing the insulation strip from between the two batteries.

Figure 32. Pulling the insulated strip from between the batteries

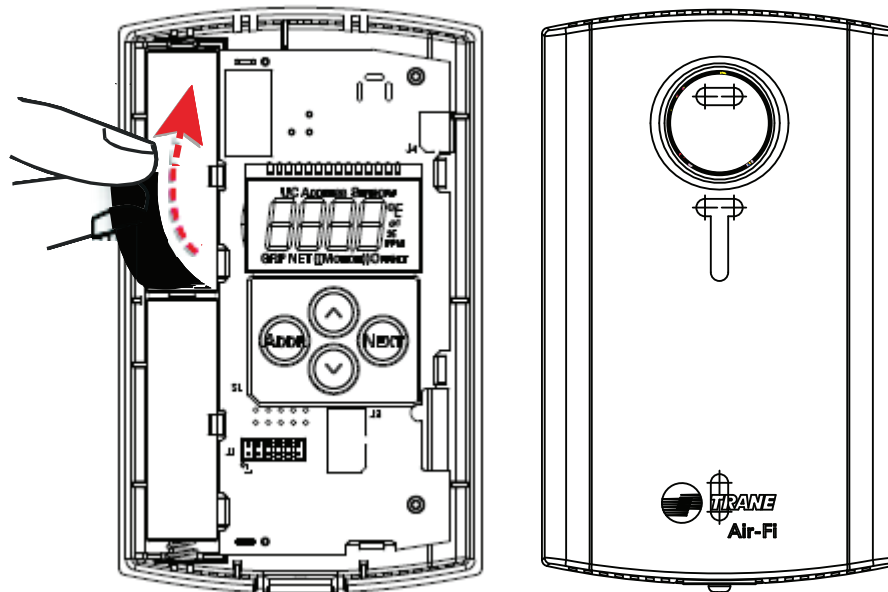

Addressing the WCS-SO, -SCO₂, -SB/R Sensor

Prior to setting addresses on the WCS, you need to know the group address (1 digit), the network address (1 digit), the unit controller address (3 digits), and sensor number (1 digit).

Notes:

- A Tracer SC group refers to all of the networks that communicate with the same Tracer SC.
- Unit controller addresses above 127 may be used for Air-Fi® Wireless systems. (Previously, with hardwired MS/TP communication, no addresses higher than 127 were allowed.)

1. Remove the cover of the sensor.

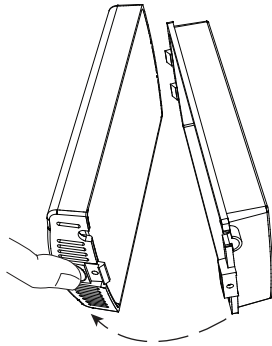
Figure 33. Removing the sensor cover

- Starting from any screen, press and hold the ADDR button for 3 seconds to put the sensor into addressing mode. The GRP icon will illuminate and the corresponding number will flash. Press the UP or DOWN arrows to set the proper Group address number.

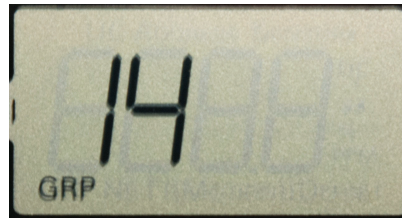

- Press the NEXT button. The NET icon will illuminate and the corresponding number will flash. Press the UP or DOWN arrows to set the proper network address number.

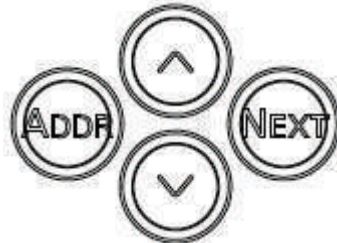

- Press the NEXT button. The UC ADDRESS icon will illuminate and the corresponding numbers will flash. Press the UP or DOWN arrows to set the proper UC address number starting with the hundreds digit. Push NEXT to set the tens digit. Finally, push NEXT again to set the ones digit..

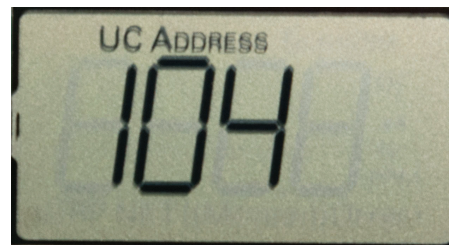

- Press the NEXT button. The SENSOR icon will illuminate and the corresponding number will flash. Press the UP or DOWN buttons to set the proper sensor number. If only one sensor is to be used, then leave the sensor number at 1. If multiple sensors are to be used, then use the UP or DOWN arrows to set the number of sensors (maximum of 6).

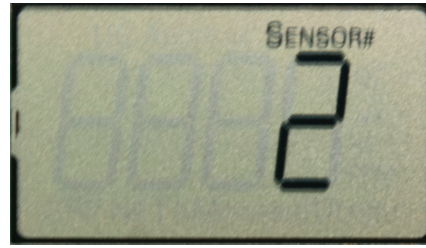

Notes:

- The total number of associated sensors affects the total number of WCIs that can communicate on the network. Refer to “Maximum Number of Air-Fi® Devices and Networks Allowed,” p. 9.
- Additional setup is required in Tracer TU for multiple sensor installations. For details, see “Using the Tracer® TU Service Tool with a Wireless Network,” p. 78.

6. Press and hold the ADDR button for 3 seconds to exit the addressing mode.

You can verify your address settings by once again pressing and holding the ADDR button for 3 seconds to return to addressing mode. Use the NEXT button to scroll through the settings.

The following figure shows the Air-Fi Wireless network example with sensors added.

Figure 34. Air-Fi Wireless network with sensors added

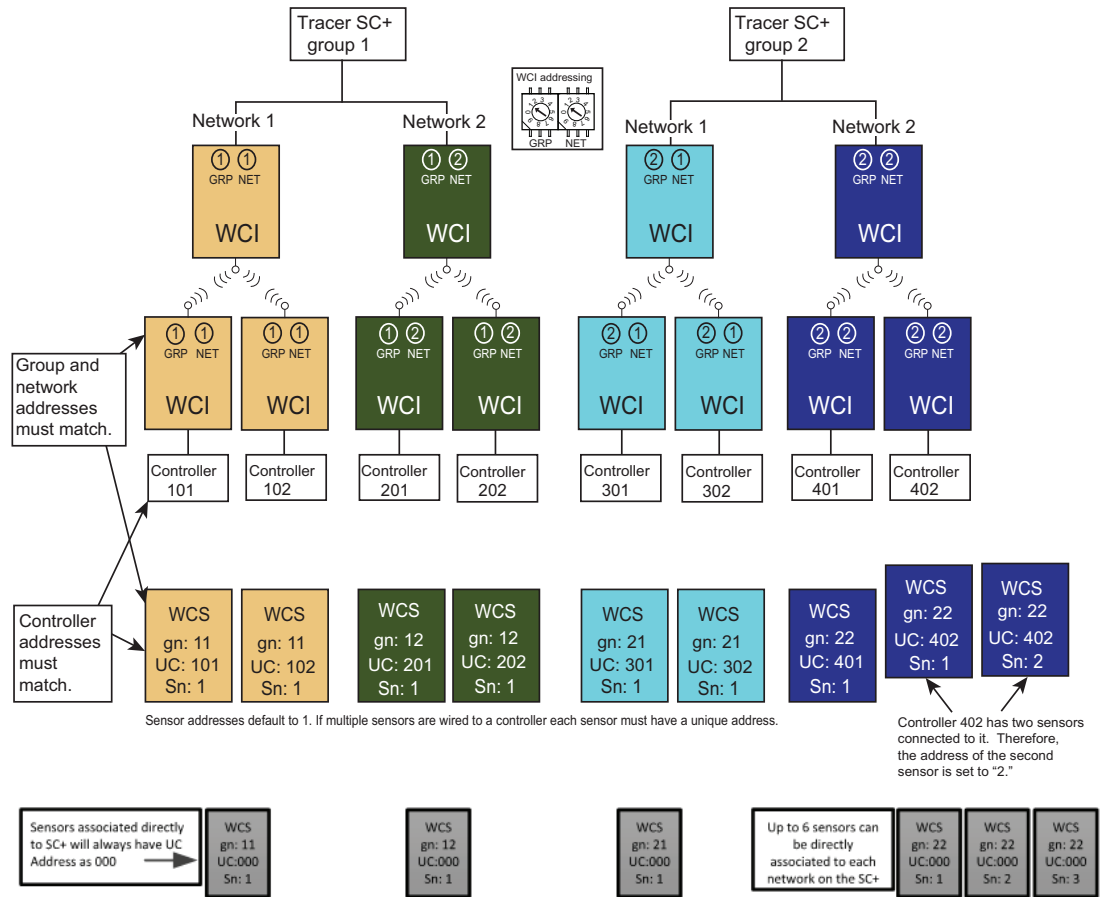

Starting with SC+ v5.10 it is possible to associate WCS sensors directly to the SC+. Sensor configuration and point creation is done using Synchrony.



WCS-SO, -SCO₂, -SB/R Network Joining and Controller Association

After addresses are set, insure the network is open, then press the UP arrow once. You will see rotating segments on the display while the sensor attempts to join the network and associate to the controller. If successful you will see signal strength displayed.

- Error code **E2** will appear on the sensor display until the WCS successfully joins the network. Until network joining is successful, the WCS will repeat its attempt to join every 60 minutes .
- Association between the WCS and the controller will automatically be initiated if not done manually. The WCS will repeat its attempt to associate every 15 minutes until successful. Error code **E1** will be displayed until association is successful.
- You can press the UP arrow at any time an error is displayed or a blank display occurs to cause the sensor to re-attempt to join the network and to associate with the WCI.

Rotating segments are displayed while the sensor attempts to join or associate. Signal strength is displayed immediately afterwards.

To verify the strength of the network signal quality and of the WCS battery charge, refer to "[Testing WCS-to-WCI Signal Strength and Battery Life](#)," p. 52.

WCS : Points and Referencers

If you have added an optional Relative Humidity module or have multiple sensors associated to a single controller, you may need to add points to be able to see these values in TU or SC. See "Referencing Individual Sensors" section for more information.

Mounting the WCS-SO, -SCO₂, -SB/R Sensor Back Plate

Important: Do not mount WCS-SO or WCS-SCO₂ sensors behind glass, clear plastic, or Plexiglas. The passive infra-red motion sensor cannot "see" through these materials and will not be able to detect motion.

To mount the sensor back plate:

1. Hold the back plate against the mounting surface and mark the screw locations.
2. Secure the back plate against the mounting surface using included hardware.

The following figure shows an example of mounting the back plate of the sensor into sheetrock or plaster.

Figure 35. Mounting the sensor backplate into sheetrock or plaster

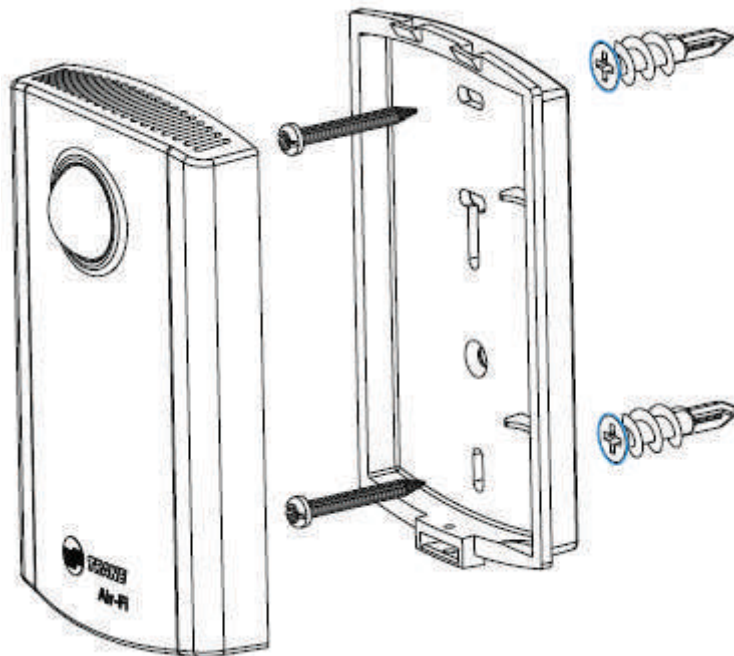

Note: WCS-SO shown. WCS-SCO₂ and -SB/R similar.

Important: To comply with FCC and IC regulations, do not mount this sensor within 20cm of any other radio device including other WCS sensors.

Wiring an External Sensor Probe to WCS-SB/R

An external temperature probe can be used by wiring it into the two position connector at the bottom of the sensor.

Recommended External Sensor: Installer supplied. Any sensor or probe that has a 10K Type 2 thermistor.

Note: This sensor also has an internal space temperature sensor which it will use in the absence of an external sensor. This allows you to use the wireless sensor as a base model space temperature sensor. To be clear, you can only use the internal temperature sensor or hook up an external temperature probe. You cannot use both at the same time.

Wire Size recommendation: For best results use solid or stranded 22 AWG. However, solid and stranded 18 to 24 AWG will also work.

Note: 18 AWG will be difficult to remove from the connector.

1. Strip insulation back 5/16 in. (8 to 9 mm). The stripped back section of wire should be straight without any kinks for best results when inserting into the connector.

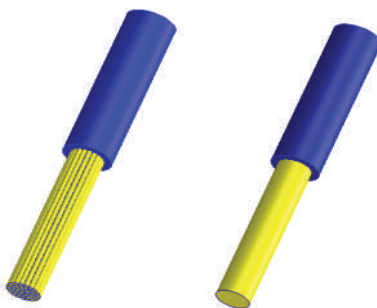
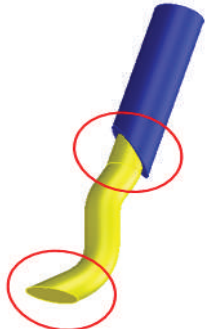

[Conductor : Bare Copper /Strand wire]

Acceptable	Non-Acceptable
 <p data-bbox="462 966 576 997">Strand Wire</p> <p data-bbox="682 966 787 997">Solid Wire</p>	 <p data-bbox="982 955 1315 1008">The insulation, conductor not be damaged in any way.</p>

2. Insert the stripped wire into the connector until you hear a faint click. Gently pull on the wire as a test to insure the wire is seated properly.

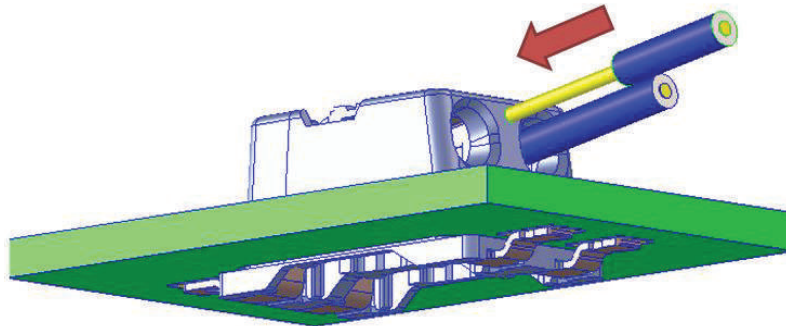

3. To remove the wire from the connector: First, push the wire into the connector slightly, then using a small screwdriver push down on the connector release tab, then pull the wire out of the connector.

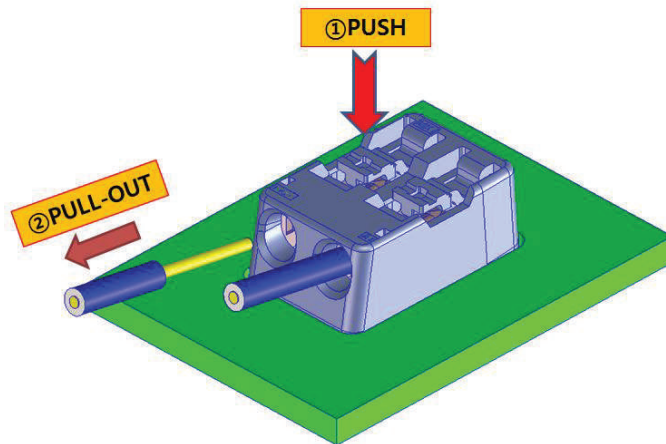

Important: The maximum wire length for the external sensor should be limited to 100 feet low capacity cable (25pf/ft or less).

Note: If you have more than one sensor associated to the same unit controller, by default the temperatures will average. This is undesirable if using the external sensor for refrigeration or freezer monitoring. Some work will be required in Tracer TU to create a new point and remove the refrigeration temperature from space temperature averaging. See “WCS-SB/R Refrigerator Temperature Sensor Setup,” p. 93 section in the Using the Tracer® TU Service Tool with a Wireless Network chapter.

Figure 36. Sensor cable routing

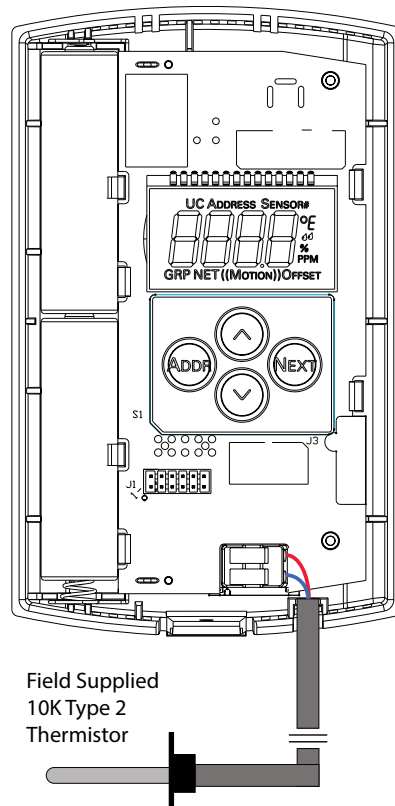

Note: When installing the WCS-SB/R sensor in a refrigerator or freezer where the temperature may fluctuate, we recommend using a Thermobuffer to slow down the temperature change. This will help preserve the battery life of the sensor.

WCS-SO, -SCO₂, -SB/R Display Sequence

Note: WCS-SO/SCO₂ sensors do not have set point, timed override, fan mode or system mode. If you need these features you will have to add a WCS-SD display sensor.

Use the NEXT and Address (ADDR) buttons to move forward or back through the sensor display sequence. Use the UP and DOWN arrows to toggle between units and increase or decrease values in their given increments.

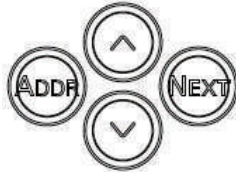

Pressing the NEXT button repeatedly displays the following conditions in this order:

1. Blank Screen or Errors
2. CO₂ (optional)
3. Temperature
4. Temperature offset
5. Humidity (optional)
6. Humidity Offset (optional)
7. Motion Test (optional)
8. Back to top

Note: Pressing the ADDR button will act like a BACK button, so you can go through the options in reverse.

Blank Screen or Errors

This screen is blank if there are no errors present. If an error is present, it will be displayed until the error condition is resolved, then the screen will be blank.



CO₂

Displays the CO₂ level in parts per million (ppm).



Note: It takes eight (8) days for a newly installed CO₂ sensor to acclimate to the environment and complete a calibration cycle.

Temperature

Use the UP or DOWN arrows to toggle between degrees F and degrees C.

**Temperature Offset**

The temperature calibration offset is adjustable in increments of 0.1 degrees F or 0.1 degrees C to a maximum of +/- 3.6 degrees F or +/- 2.0 degrees C.

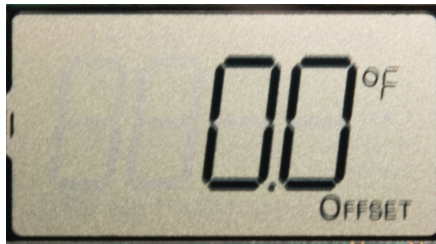
**Relative Humidity**

Displays relative humidity in 0.1% increments. See “RH Sensor Module” that follows in this subsection for more information about the RH Humidity sensor module.

**Relative Humidity Calibration Offset**

Use UP and DOWN arrows to adjust the RH humidity calibration offset in increments of +/- 0.1% RH to a maximum of +/- 5.0% RH.

**Motion Test**

In this mode, the display will count down from 120 seconds giving the installer 2 minutes to adjust the sensor position for proper range for the area. When motion is detected within the range of the beam, the sensor eye will glow red briefly.

Figure 37. Sensor eye turns red when motion is detected



This adjustment is necessary for both WCS-SO and WCS-SCO₂ versions. The WCS-SCO₂ version has a built-in occupancy sensor. It is used to reduce the number of CO₂ samplings when the space is unoccupied to conserve battery life.

It is assumed the sensor has been mounted in a position where occupancy or CO₂ will be monitored. The maximum range for the occupancy sensor is 32 feet (10 meters). Set the sensor in Motion Test mode and wait for the red light to go off. Walk through the area and watch the sensor eye illuminate red indicating your presence is sensed. Make any mounting adjustments to achieve the best overall position of the sensor where it will detect human traffic.

Reference the occupancy sensor coverage pattern below to help determine the best mounting position.

Figure 38. WCS-SO sensor coverage patterns

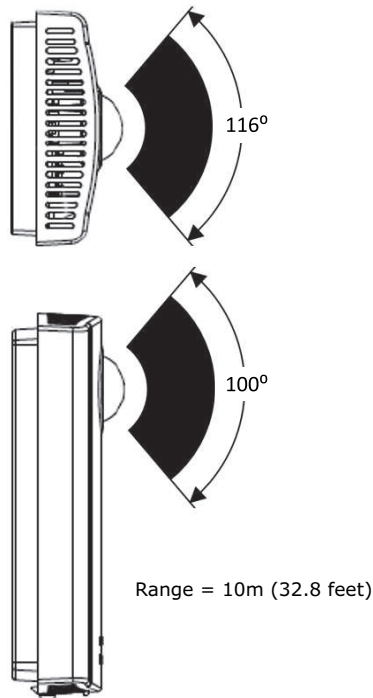

If more time is needed than the default 120 seconds, you can press the UP arrow to add time in 30 second increments to a maximum of 600 seconds.

RH Sensor Module Installation

A 2% relative humidity (RH) sensor module, available as a separate part (X13790973030; model WCS-SH), can be installed on a WCS either before or after the WCS is powered up as shown in the following figure. If the RH sensor module is installed on the WCS after power-up, the WCS will detect it when you pull out the battery to shut off the sensor, then put the battery back in to turn the sensor on.

Figure 39. Relative humidity sensor module installation

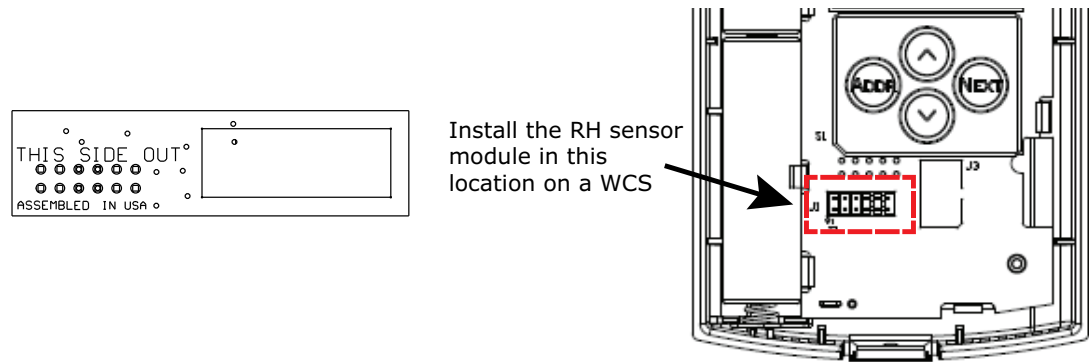

A WCS with an RH sensor module installed on it displays the RH humidity measurement when you scroll through the display sequence.

Note: If using a WCS-SB/R with a humidity sensor module, humidity reading will come from the location of the mounted sensor, not the external probe location.

Replacing the Sensor Cover

To replace the cover, hook the cover over the top of the back plate. Apply light pressure to the bottom of the cover until it snaps in place.

WCS-SO, -SCO₂, -SB/R Error Codes

Each error code is described in the following table.

Possible Cause	Explanation/Resolution
Sensor is not associated with UC (E1)	<ul style="list-style-type: none"> Verify that the unit controller and WCI firmware are up to date. The configured address in the sensor does not match the dials of a UC for any WCI in the same wireless network. Re-associate the sensor with the WCI by correcting the UC address in the sensor. <div style="text-align: center;"> <p>Match to UC</p> </div> <p>Refer to "WCS-SO, -SCO₂, -SB/R Network Joining and Controller Association," p. 44 for information about E1 and E2 errors.</p>
Sensor has not joined the network. (E2)	<ul style="list-style-type: none"> Verify that the network is open. Normal for sensor configured with GRP-NET 0-0. Verify that the sensor has the correct group (GRP) and network (NET) addresses. Verify that the sensor is within radio range. If the sensor has previously joined the network, verify that WCIs in range are powered up. From the blank screen or error screen, press the UP arrow to force manual association. Otherwise, set the correct GRP and NET addresses and open the wireless network to allow the sensor to join. <p>Refer to "WCS-SO, -SCO₂, -SB/R Network Joining and Controller Association," p. 44 for information about E1 and E2 errors.</p>

WCS–SO/SCO₂ and –SB/R Installation

Possible Cause	Explanation/Resolution
Sensor drains battery current during sleep (E3)	If the error persists and batteries drain prematurely, the sensor may have defective components and need to be replaced.
Internal failure (E7)	Replace the sensor.
Wrong sensor address (E8)	The configured sensor address does not match the sensor address that is expected by the UC. Use Tracer TU to configure the UC for the quantity of sensors it should accept, if more than one.
Duplicate sensor (E9)	Another sensor with the same configured UC address and sensor address is already associated with the UC. Resolve the duplication. This may involve waiting (up to 34 minutes) for the UC to forget the address of a failed sensor.



Testing WCS-to-WCI Signal Strength and Battery Life

The WCS-SO, -SCO₂, -SB/R sensors display the following symbols for signal and battery:

- **S**—Indicates signal strength (from Home screen press UP arrow once).
- **b**—indicates battery life (from Home screen press DOWN arrow once)

The following symbols are appended to the S or b:

Table 9. Signal strength and battery life symbols

	<ul style="list-style-type: none"> • Excellent signal quality (Equals green link on the Tracer TU network health map.) • 100 — 50% battery life remaining
	<ul style="list-style-type: none"> • Satisfactory signal quality (Equals yellow link on the Tracer TU network health map.) • 50 — 3% battery life remaining
	<ul style="list-style-type: none"> • Poor signal quality resulting in unreliable communication (Move sensor or WCI to a better location, if necessary.) • Less than 3% battery life remaining

The following display indicates excellent signal quality::

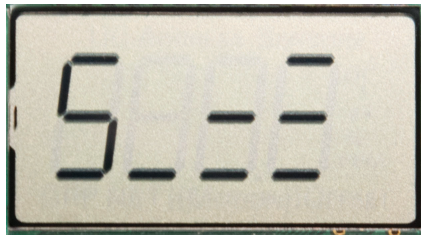

The following display indicates 100% – 50% battery life:

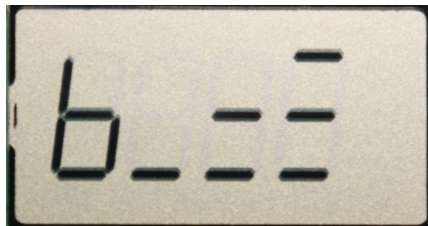



WCS-SB/SD Configuration

The configuration of the WCS-SB/SD determines which system features can be accessed and changes can be made by the tenant (for example, changes to cooling/heating mode, setpoint, or fan speed). Verify system and associated unit features before configuring the sensor.

The building owner or operator may choose to limit tenant access to certain features. This can be done through configuration. Or, if a sensor is configured to match all controllable features of the associated equipment, the locking feature can be used to restrict the tenant from making changes.

Configuration Procedure

To configure the features of the WCS-SB/SD, follow this procedure in the order presented.

1. Remove the cover of the WCS-SB/SD.
2. Press the configuration button for 3 seconds

Figure 40. Pressing the configuration button to enter configuration mode

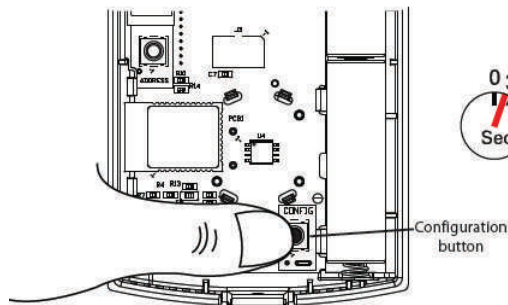

The display will change to configuration mode. In configuration mode, a wrench symbol appears on the display and the menus are separated by lines, as illustrated below.

Note: To view the display on the base model of the sensor (WCS-SB), turn the sensor over to the back.

Figure 41. Wrench symbol signifying configuration mode



3. Press the center button on the keypad one time to begin the configuration process.

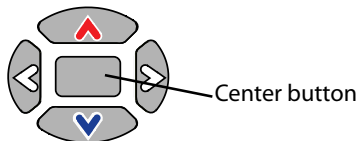

WCS-SB/SD Configuration

4. Configure the sensor options in the order shown in the table.

- Press or to scroll to the next selection (as illustrated).
- Press or to move to the next menu (as illustrated).

Table 10. WCS—SB/SD configuration options

Setting	Configuration options
Temperature <ul style="list-style-type: none"> • Choose Fahrenheit or Celsius • Choose the degree resolution (whole degrees, half degrees, or tenths of degrees). 	
Setpoint	
Deadband (available for dual setpoint system only) <i>Note: Deadband refers to the minimum difference between the heating and cooling setpoints.</i>	
System a) Single setpoint	
System (continued) b) Dual setpoint	
System (continued) c) No setpoint	

Table 10. WCS—SB/SD configuration options (continued)

Setting	Configuration options
Fan <i>Note: Not all fan options are available for all systems.</i>	<p> auto/off auto/off/low/high auto/off/low/med/high auto/high (on) off/high (on) off/low/high off/low/med/high no fan options enabled </p>
Occupancy (timed override)	<p> occupancy enabled occupancy disabled </p>
Temperature calibration offset	<p>The reported temperature can be adjusted in increments of 0.1°F or 0.1°C, depending on unit configuration, to a maximum of ±3.6°F (±2°C).</p> <p>Adjustable in increments of 0.1°F or 0.1°C to a maximum of ±3.6°F or ±2°C</p>
Humidity calibration offset <i>Note: Available if the RH module is installed on the WCS.</i>	<p>The reported humidity can be adjusted in increments of 0.1% RH to a maximum of ±5%RH.</p> <p>Adjustable in increments of 0.1%RH to a maximum of 5.0%RH</p>

5. Review the display to ensure that you have selected the correct configuration options.

The example shows a display that has been configured for:

- Dual setpoint
- Temperature units (Fahrenheit)
- Temperature resolution to tenths of a degree
- System settings: Emergency Heat, Heat, Cool, Off
- Fan settings: Auto or On
- Occupied/unoccupied option enabled

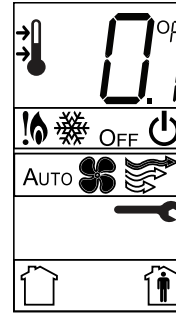

- To return the display to operating mode, press the configuration button, press the center button on the keypad once.

Note: The sensor will revert to operating mode if no buttons are pressed for 10 minutes.

Example of a Configured WCS-SD Display

The following example shows a configured display in operating mode.



Display shows the following:

- Temperature units (Fahrenheit)
- Temperature resolution to tenths of a degree
- System setting: Cooling
- Fan setting: Auto
- Occupied/Unoccupied option enabled

If an error code exists, it appears at the bottom center of the display, as shown below. View definitions on the inside of the back plate or see “Sensor does not communicate with WCI.” under “[Troubleshooting and Maintenance](#),” p. 70.

Error Codes

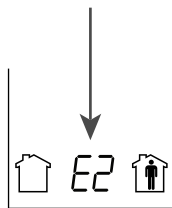

Optional Features

Perform the following procedures as needed.

Displaying Setpoint or Temperature

You can configure the sensor to display either the temperature (default) or the setpoint. To select either option:

1. Verify that the sensor is in operating mode and that the home screen is displayed.
2. Toggle between the temperature and setpoint screens by pressing the up and down arrows for 3 seconds. The arrow to the left of the temperature indicates that it is the setpoint.

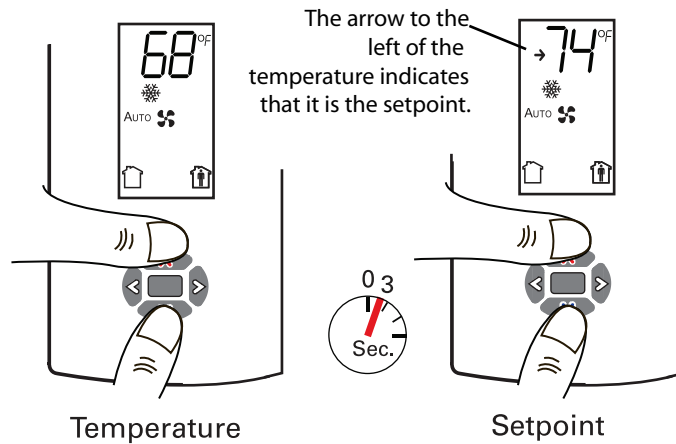

Locking or Unlocking Settings

You can lock or unlock the setpoint, system, or fan setting to prevent changes.

To lock or unlock a setting:

1. Verify that the sensor is in operating mode and at the home screen.
2. Choose a setting to lock or unlock:
 - Select the setpoint by pressing the up or down arrow.

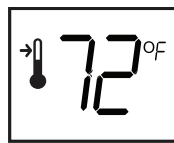

Setpoint

- Select the system menu by pressing the center button. Use the left or right arrow to choose the setting.



System menu

- From the system menu press the down arrow to select the fan menu. Use the left or right arrow to choose the setting.

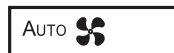

Fan menu

3. Press the left and right arrows for 4 seconds.

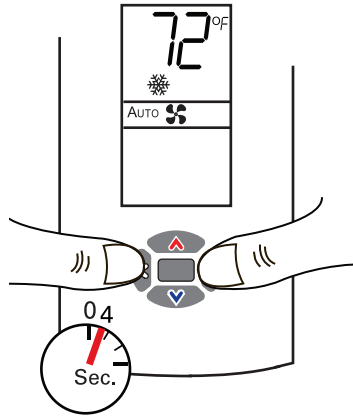

Note: If you try to access a feature that is locked, the locked symbol will appear on the display. The locked symbol will flash if you press a keypad button to try change the setting of a locked feature.

Star (*)/Double Star (**) Function

Star/Double Star function is available on sensor models WCS-SD and WCS-SB if the sensor is configured for single setpoint operation. Press and hold the UP or DOWN arrow to display the Star (*) or Double Star (**) respectively, on the sensor display.

Figure 42. Star/double star function on sensor models

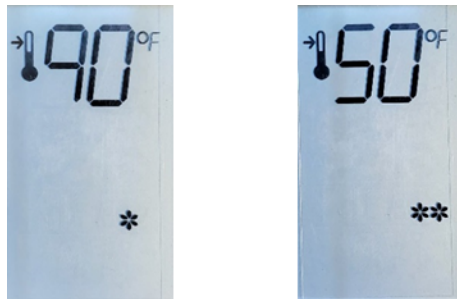

- If the setpoint is increased to the top of the range, 90 and * appear on the display. The * indicates the Unit Controller is requested to be in Air Flow Override mode where the damper will be driven to maximum position.
- If the setpoint is decreased to the bottom of the range, 50 and ** appear on the display. The ** indicates the Unit Controller is requested to be in Air Flow Override mode where the damper will be driven to minimum position.
- When the setpoint is adjusted for Star or Double Star mode, the communicated setpoint remains at the last value, not 90 or 50 as the display may lead you to believe. To change this behavior view HUB document 201364 "Space temperature setpoint active does not change when adjusting the Air-Fi sensor to 50** °F or 90* °F.

Note: Air Flow Override is a multistate input point that is put out of service by default. Air Flow Override is only used on VAV units.

Replacing the Sensor Cover

To replace the cover:

1. Hook the cover over the top of the back plate. Apply light pressure to the bottom of the cover until it snaps in place.
2. Install the security screw into the bottom of the cover (if desired).

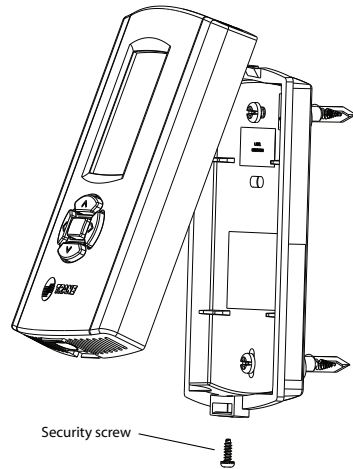

Viewing Unit Controller Operating Status

To view unit controller operating data on the WCS-SB/SD display, press the center button twice. This data will appear in addition to the signal test report and battery status (see [“Testing WCS Signal Quality and Battery Life,” p. 74](#)) if the WCS-SB/SD is associated with a unit controller that provides this additional information. The data may include the active setpoint (displayed in the top digits area), the system mode (displayed in the heat/cool/auto/off icon area), and the system fan status (on/off displayed in the fan speed area). If there is an error, the error code will be displayed instead of the unit controller data. Areas for which no data is provided by the unit controller remain blank. (Unit controllers with old firmware are compatible with the WCS-SB/SD, but they do not provide additional data for the WCS-SB/SD to display.)

Establishing an Air-Fi® Network

When all aspects of hardware installation are complete, you are ready to power up the system and establish the wireless network. Before powering up, ensure that all of the procedures described in “WCI Installation,” p. 24 and “WCS-SB/SD Installation,” p. 35 have been completed.

Best Practice: Set rotary dial addresses on each controller before applying power.

Note: BCI2-I and BCI2-R do not have rotary dials; a default address is set at the factory, which is printed on a label. If that address does not work, either Tracer TU or the embedded BCI2 service tool must be used to set the address.

Power up all devices in the network at the same time. If you are unable to do this, power them up in the following order:

1. All WCIs.
2. All unit controllers: UC210, UC400, UC600, BCI-I, BCI-R, BCI2-I, BCI2-R, Symbio™ 210/210e, Symbio™ 400-B/500, Symbio™ 700, Symbio™ 800.
3. The Tracer SC+ (always set rotary address before applying power).
4. WCSs, if present.

Note: If the coordinator WCI is powered up 1 hour or more before the other devices on the network, then you must open the network manually or with Tracer TU.

When applying Air-Fi® Wireless sensors with hardwired BACnet network communication (BACnet MS/TP or BACnet/IP), refer to “Installing Air-Fi Wireless Sensors with BACnet MS/TP or BACnet/IP,” p. 64 section.

WCI LEDs and Buttons

Before establishing a network, you should be familiar with the layout of the WCI board, the behavior of its LEDs, and the function of its buttons. The WCI board contains two buttons and several LEDs. The LEDs relevant to network formation are shown in the following figures.

Figure 43. LEDs and buttons related to network formation (WCI version 1 and 2 built prior to 2019)

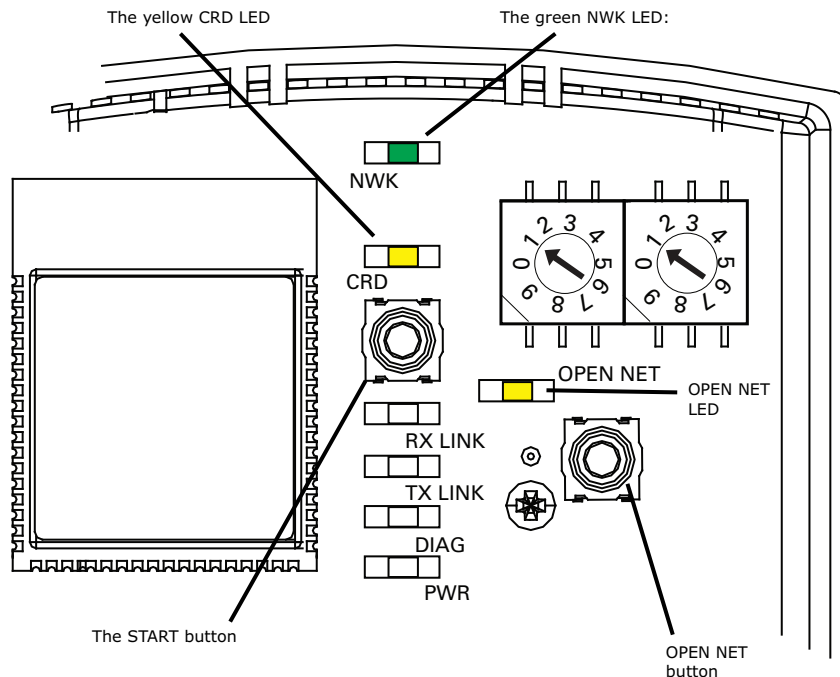
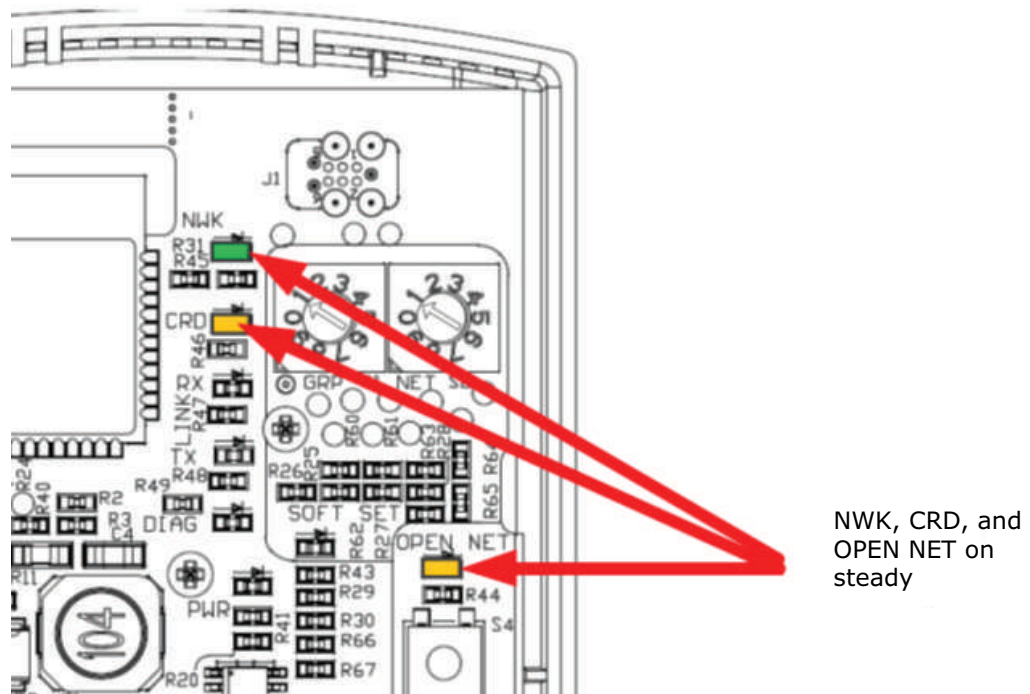

Figure 44. Identifying network coordinator on version 3 WCI built 2019 and after



NWK, CRD, and OPEN NET on steady

Table 11. Description and behavior of the WCI LEDs and buttons

LED or Button	Description and Behaviors
The green NWK LED	<ul style="list-style-type: none"> • Illuminates on every WCI that has joined the network. • Flashes for 10 seconds every 2.5 minutes if the WCI is not a member of the network.
The yellow CRD LED	Illuminates on the coordinator WCI.
The OPEN NET LED	This LED is illuminated if the network is open for new devices to join.
The START button	<ul style="list-style-type: none"> • On a network without a Tracer SC, designates a WCI as the network coordinator and opens the network for new devices to join. (See “Establishing the Network Prior to Tracer SC+ Installation or Without Tracer SC+ Installation,” p. 63.) • Removes a member WCI from the network. (See “Removing a WCI from a Network,” p. 68.) • Disbands the network. (See “Disbanding a Network,” p. 69.)
Pressing the OPEN NET button:	<ul style="list-style-type: none"> • On a coordinator WCI, opens or closes all devices for at least one hour. (Time may be extended if devices are joining.) • On other WCIs, opens or closes only that WCI for 10 minutes.

On power-up, the WCI goes through a check list and updates LED activity according to the type of device associated with the WCI and the status of the WCI in the network. The LED flash patterns vary depending on current conditions. LED behavior is described in the following table.



Establishing an Air-Fi® Network

Table 12. LED identification and interpretation

LED	LED activity	Indicates...
Network LED (green) NWK	On solid	WCI is a network member.
	Flashes for 10 seconds every 2.5 minutes.	WCI is not a member of a network. The WCI will join a network when the NWK LED is flashing. If there is an open network nearby with the same rotary settings and the WCI joins the network, the NWK LED turns on solid and then the OPEN LED turns on solid.
	Double Flash Pattern	Router WCI searching for coordinator after losing communication with coordinator.
Coordinator LED (yellow) CRD	On solid	WCI is network coordinator.
Open Net LED (yellow) OPEN NET	On solid	Network is open for joining.
	Off	Network is closed for joining.
Reception LED (yellow) RX LINK	Flashing ^(a) On ^(b) Off ^(c)	Data received. Data received No data received
Transmission LED (green) TX LINK	Flashing ^(d) On ^(e) Off ^(f)	Data transmitted Data transmitted No data transmitted
Diagnostic LED (red) DIAG^(g)	Off	Normal operation
	Flashes (1/2 second on, 1/2 second off repeating)	Hardware failure or failed re-flash of a radio. Corrective action: Replace the WCI
	Triple flash pattern.	Failed to join network. Occurs for 30 seconds after failing to join a network. Will continue this pattern until successful join. Corrective action: Insure network is formed and open, then allow time for WCI to join on its own.
Power LED (green) PWR	On solid	WCI has power.
	Off	WCI does not have power. Corrective action: Check WCI power wiring for 24v DC or AC.

^(a) LED will flash steady (about 3 flashes per second) on WCI that was built prior to 2019.

^(b) LED will appear to be on steady for WCI built 2019 and after. Will appear dim and flicker occasionally according to how much data is passing.

^(c) LED is off for all WCI.

^(d) LED will flash steady (about 3 flashes per second) on WCI that was built prior to 2019.

^(e) LED will appear to be on steady for WCI built 2019 and after. Will appear dim and flicker occasionally according to how much data is passing.

^(f) LED is off for all WCI.

^(g) If more than one condition is present, the priority is in the order listed.

Three Ways to Establish an Air-Fi® Network

An Air-Fi network can be established in the following situations:

- After a Tracer SC+ has been installed.
- Prior to Tracer SC+ installation.
- On a network that will not have a Tracer SC+ installed on it. This scenario includes applications that combine Air-Fi Wireless sensors with hardwired BACnet network communication, both BACnet MS/TP and BACnet/IP.

Establishing the Network After Tracer SC+ Installation

If a Tracer SC+ is installed prior to establishing the Air-Fi network, the WCI that is installed on a Tracer SC+ automatically becomes the network coordinator after power is applied to the Tracer SC. If multiple WCIs are installed on a Tracer SC+, each WCI forms an independent network for which it is the coordinator.

Follow this procedure:

1. Observe the yellow CRD LED on the WCI illuminate to identify the WCI wired to the Tracer SC as the network coordinator (see “WCI LEDs and Buttons,” p. 60.)
2. Observe the yellow OPEN_NET LED illuminate on the coordinator WCI. This LED remains lit for 1 hour, indicating that the network is open to allow WCIs with matching addresses to join the network for that duration. After each WCI joins, the 1 hour timer starts over.

Note: *If the network closes because the timer has expired, you can open the network for an additional hour by pressing the OPEN_NET button on the network coordinator WCI. To extend time on a network that has not yet closed, press the OPEN_NET button on the coordinator to close the network, then press it again to open the network for an additional hour. As an alternative, you can use Tracer TU to open the network.*

3. Observe the green NWK LED illuminate:
 - On the coordinator WCI, indicating that it is a member of its own network.
 - On each additional WCI as it joins the network.

Note: *Typically, it takes about 10 minutes for a WCI to join the network. However, the time is dependent on the distance between the WCIs in network as well as the size and type of structures that may exist between them.*

4. After the network is formed, press the OPEN_NET button on the coordinator to close the network if it is still open (indicated by an illuminated OPEN_NET LED).
5. To enable and configure Tracer SC+ for the new wireless network, see Tracer SC+ Online Help and the current edition of the *Tracer® SC System Controller - Installation, Operation, and Maintenance* (BAS-SVX31*-EN).

Establishing the Network Prior to Tracer SC+ Installation or Without Tracer SC+ Installation

If a Tracer SC+ has not been installed at the time that you are ready to establish the network or will never be installed on the network, follow this procedure to establish the network.

Task 1: Activate Communication Among Existing WCIs

1. Choose a centrally located WCI that has been wired to a unit controller to become the network coordinator.

Note: *Record the location of this WCI if the network is to have a Tracer SC+ installed on it at a later time. In that case, you will have to disband the network from the coordinator WCI so that the WCI that has been installed on the Tracer SC+ can become the network coordinator and establish a new network, as explained in detail in Task 2.*

2. Press the START button for 5 seconds to establish the WCI as the coordinator and to open the network for joining. The yellow CRD LED on the WCI illuminates to identify the WCI as the network coordinator. (See “WCI LEDs and Buttons,” p. 60.)
3. Observe the yellow OPEN_NET LED illuminate on the coordinator WCI. This LED remains lit for 1 hour, indicating that the network is open to allow WCIs with matching addresses to join the network for that duration. After each WCI joins, the 1 hour timer starts over.

Note: *If the network closes because the timer has expired, you can open the network for an additional hour by pressing the OPEN_NET button on the network coordinator WCI. To extend time on a network that has not yet closed, press the OPEN_NET button on the coordinator to close the network, then press it again to open the network for an additional hour.*

4. Observe the green NWK LED illuminate:

Establishing an Air-Fi® Network

- On the coordinator WCI, indicating that it has joined its own network.
- On each additional WCI as it joins the network.

Note: Typically, it takes about 10 minutes for a WCI to join the network. However, the time is dependent on the distance between the WCIs in network as well as the size and type of structures that may exist between them.

5. After the network is formed, press the OPEN_NET button on the coordinator to close the network if it is still open (indicated by an illuminated OPEN_NET LED).

Task 2: Installing a Tracer SC+ After Network Formation

Before a Tracer SC+ is installed on a previously established network, the network must be disbanded and then re-established. Follow this procedure:

1. On the WCI that is currently the network coordinator, press the START button for 10 seconds. The network will disband.
2. Install an addressed WCI on the Tracer SC+ following addressing and wiring instructions (see “WCI Installation,” p. 24).

After power is restored to the Tracer SC+, the WCI that is installed on the Tracer SC automatically becomes the network coordinator and a new network is established.

3. Observe the yellow OPEN_NET LED illuminate on the coordinator WCI. This LED remains lit for 1 hour, indicating that the network is open to allow WCIs with matching addresses to join the network for that duration. After each WCI joins, the 1 hour timer starts over.

Note: If the network closes because the timer has expired, you can open the network for an additional hour by pressing the OPEN_NET button on the network coordinator WCI. To extend time on a network that has not yet closed, press the OPEN_NET button on the coordinator to close the network, then press it again to open the network for an additional hour.

4. Observe the green NWK LED illuminate:
 - On the coordinator WCI, indicating that it has joined its own network.
 - On each additional WCI as it joins the network.

Notes:

- Typically, it takes about 10 minutes for a WCI to join the network. However, the time is dependent on the distance between the WCIs in network as well as the size and type of structures that may exist between them.
 - Sensors do not immediately figure out that the old network has been disbanded. They are asleep to conserve battery power, and they do not display an E2 right away. It can take up to five minutes for a sensor to detect that the old network is gone, but then they will display an E2 until they join the new network.
 - The fastest way to get the sensor to join the newly formed network is to Open the network using TU or pressing the Open Net button on the coordinator, then go to each sensor and force the sensor to join by pressing the center button twice on WCS-SB/SD sensors, or pressing the UP arrow once on the WCS-SO, -SCO2, -SB/R sensor. You may have to repeat the button press a few times before the sensor joins.
5. After the network is formed, press the OPEN_NET button on the coordinator to close the network if it is still open (indicated by an illuminated OPEN_NET LED).
 6. To enable and configure Tracer SC+ for the new wireless network, see Tracer SC Online Help and the current edition of the *Tracer® SC System Controller - Installation, Operation, and Maintenance* (BAS-SVX31*-EN).

Installing Air-Fi Wireless Sensors with BACnet MS/TP or BACnet/IP

Air-Fi Wireless networks normally include network and sensor communication between all WCIs and WCSs. Other applications include Air-Fi Wireless sensors with BACnet MS/TP or BACnet/IP (hardwired or Wi-Fi). In those cases, network communication between the Tracer SC+ and unit controllers may be BACnet MS/TP (hardwired) or BACnet/IP (hardwired or Wi-Fi). With the addition of WCIs on each unit

controller, Air-Fi wireless capability enables connectivity to the wireless sensors.

For these applications with BACnet MS/TP or BACnet/IP network communication and wireless sensors, a WCI coordinator at the Tracer SC+ is NOT required. Instead, one unit controller WCI is designated as a coordinator – exactly one coordinator for each network. Refer to the instructions below for proper installation.

To begin, configure the unit controllers, WCIs, and sensors as if the network configuration was Air-Fi Wireless. Once the Air-Fi Wireless operation is confirmed, change the network communication protocol from Air-Fi Wireless (BACnet over Zigbee) to BACnet MS/TP or BACnet/IP. By first establishing the Air-Fi Wireless connections, the controller automatically sets up the sensor reference(s) for the WCI.

Important: *Concurrent Air-Fi Wireless (BACnet over Zigbee) and BACnet MS/TP or BACnet/IP communication is **NOT supported on any of the BACnet Communication Interfaces (BCI/BCI2)**. For those devices, apply and configure each as either wireless or wired.*

1. With power removed, use the rotary settings to uniquely address each controller on the network. This setting establishes the BACnet MS/TP address, if applicable, and determines the Device ID for each controller for both BACnet MS/TP and BACnet/IP.
2. **For Symbio™ 210e only**, connect with Tracer TU via USB and change the communication protocol from BACnet IP to BACnet Air-Fi prior to applying power to the controller. All other controllers will automatically detect the presence of the WCI on power up and automatically change the protocol to BACnet Air-Fi.
3. Choose a WCI on a unit controller that is centrally located within the other unit controllers that will be on the same network to become the network coordinator. One coordinator is required for each wireless network.
4. Set the GRP and NET rotaries on each WCI based on their network affiliation, noting that more than one network may be required for a particular application. Each network should be limited to about 20 WCIs for best performance.
5. Apply power to the unit/controller. Confirm that the Rx and Tx LEDs are on solid on the WCI, proving the unit controller and WCI are communicating.

Note: *The Rx and Tx LED's will flash on older V1 and V2 WCI's (pre-2019).*

6. On the WCI chosen as the coordinator, press the START button for 5 seconds to establish the WCI as the coordinator and to open the network for joining. The yellow CRD LED on the WCI illuminates to identify the WCI as the network coordinator. The NWK LED will also illuminate. (See “WCI LEDs and Buttons,” p. 60.)
7. Observe the yellow OPEN_NET LED illuminate on the coordinator WCI. This LED remains lit for 1 hour, indicating that the network is open to allow WCIs with matching addresses to join the network for that duration. After each WCI joins, the 1-hour timer starts over.

Note: *If the network closes because the timer has expired, you can open the network for an additional hour by pressing the OPEN_NET button on the network coordinator WCI. To extend time on a network that has not yet closed, press the OPEN_NET button on the coordinator to close the network, then press it again to open the network for an additional hour.*

8. The green NWK LED will illuminate on each additional WCI as it joins the network.
Note: *Typically, it takes about 10 minutes for a WCI to join the network. However, the time is dependent on the distance between the WCIs in network as well as the size and type of structures that may exist between them.*
9. Once all the WCIs have joined, address and associate the wireless communicating sensors (WCS) to each associated unit controller. (Observe the maximum of 6 wireless sensors per unit controller, as long the maximum wireless device count for the network is not exceeded).
10. After the network is formed, press the OPEN_NET button on the coordinator to close the network if it is still open (indicated by an illuminated OPEN_NET LED).
11. Using Tracer TU, connect directly to each unit controller. From the Controller Settings page, confirm the Protocol as “BACnet Air-Fi” (BACnet/Zigbee).
12. Cycle power to the controller with BACnet/Zigbee selected. This will automatically reference the applicable analog information from the WCI/WCS to the associated unit controller.

Establishing an Air-Fi® Network

13. From the Analog tab, confirm the reference source for each applicable input as “wci”. While some sensors commonly share the Space Temperature Local and Space Temperature Setpoint Local, other value may also be passed for the optional sensor features such as occupancy and CO₂.

Instance	Name	Value	Units	Reference
Analog Input Create New...				
<input type="checkbox"/> 1	Space Temperature Local	71.7	'F	wci.spaceTemp
<input type="checkbox"/> 2	Space Temperature Setpoint Local	74	'F	wci.coolSetpt

14. Remove power from each unit/controller. Connect the network wiring, either BACnet MS/TP or BACnet/IP. Reapply power to each unit/controller.
15. Using Tracer TU, connect directly to each unit controller. From the Controller Settings page, adjust the Protocol by selecting “Enable BACnet MS/TP Communication” or “BACnet/IP”.

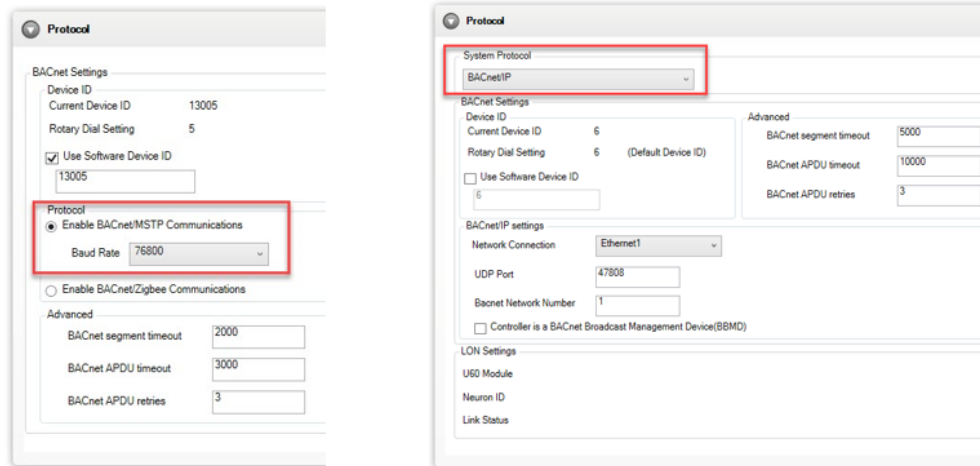

16. Unless DHCP is used to determine the unique IP address for each controller, use Tracer TU to uniquely configure each IP address (BACnet/IP only).
17. Consider naming each unit controller with WCI coordinator in a way that easily identifies it as such. (Example: VAV 08-03 Sensor Coordinator 1-4).
18. Proceed with device discovery and installation in Tracer Synchrony for all BACnet MS/TP or BACnet/IP devices.

Using Tracer TU with Air-Fi® Wireless Sensors and BACnet MS/TP or BACnet/IP

The existing Air-Fi® Wireless functionality in Tracer TU has been optimized for fully Air-Fi Wireless systems, both network and sensor communication. As such, some of the functionality in Tracer TU behaves differently for applications with Air-Fi® Wireless and BACnet MS/TP or BACnet/IP network communications.

The following items summarize the Tracer TU differences between Air-Fi® Wireless networks (BACnet over Zigbee) and Air-Fi® Wireless sensors applied with BACnet MS/TP or BACnet/IP network communication.

Note: Connecting with the Tracer TU wireless adapter is recommended only for wireless troubleshooting or testing. All other Tracer TU tasks should be accomplished with a direct USB connection or connection through the Tracer SC/SC+.

- For wireless troubleshooting tasks, use the Tracer TU adapter to attach with the unit controller acting as the coordinator. This provides the most functionality.
- Use one of the two options to open the network, a prerequisite to joining wirelessly:
 1. Press the ‘Open Net’ button on the coordinator WCI.
 2. Using Tracer TU, connect directly to any UC in the network and click ‘Open Network’ under the Wireless menu.

- When directly connected to Tracer SC+ the 'Open Network' button appears to be available under the wireless menu but does not currently work. Instead, connect directly with one of the unit controllers in the network.
- The functionality of the left-hand navigation (LHN) may be compromised depending on your circumstances. For example, the tree may not consistently show the device name as expected. To refresh, select the Wireless menu and List Devices. Use this list to Attach to a device that is not showing up as expected. Alternately, try Device Discovery to repopulate the LHN.
- Some of the functionality under Network Health may also behave differently.
 - Unit name may display as a "short Address".
 - BACnet Message column may show unreliable information at times, depending on the circumstances.
- Channel Quality Scan may not scan as fast as expected.
- Communication History is not available.
- Under the Wireless menu, Advanced is not a valid option when not connected to a Tracer SC/SC+ coordinated network. As such, you will not be able to change the Zigbee channel using Tracer TU. To change the channel, manually disband the network, change each WCI NET rotary dial to a new channel, then change each sensor address to match.
- Under Wireless menu, Network Details may show incomplete information. The GRP-NET may show as 0-0 and the coordinator rotary address may not be shown.
- Facility View may not show all the devices in the network. You may have to refresh the navigation tree with Device Discovery. The user experience with Facility View improves by directly connecting to a unit controller with a USB cable, followed by a Device Discovery.
- None of the functions under the Wireless menu work when direct connected to the SC+. If you need any functions from the Wireless menu, connect directly to the unit controller acting as the network coordinator.



Modifying an Air-Fi® Network

This section describes how to modify an established Air-Fi network. Most modifications can be made by using either the Tracer® TU service tool or the WCI.

To use Tracer TU, you must establish communication with a wireless network and attach to a wireless device. For instructions, see [“Using the Tracer® TU Service Tool with a Wireless Network,” p. 78.](#)

Adding WCIs to an Existing Network Using Tracer TU

1. After attaching Tracer TU to a wireless device, select **Open Network** from the Wireless menu.
Every member WCI will indicate that the network is open. Any WCI with a correct rotary address setting that is located within radio range of a network member, will join the network.
2. Observe the green NWK LED illuminate on a WCI that joins the network.

Adding WCIs to an Existing Network Using a WCI

1. Press the OPEN_NET button on the network coordinator WCI to open the network for joining for one hour. Every member WCI will indicate that the network is open. Any WCI with a correct rotary address setting that is located within radio range of a network member, will join the network.
Note: Pressing the OPEN_NET button on a member WCI will open only that one WCI.
2. Observe the green NWK LED illuminate on a WCI that joins the network.

Adding Coordinators to a Tracer SC+

A Tracer SC+ can have a total of eight WCIs installed on it. Each WCI installed on a Tracer SC+ becomes the coordinator of a separate network. If additional coordinator WCIs/networks are needed on a Tracer SC+ after the network has been formed, follow these steps.

1. Address the new WCI(s) according to the scheme explained in [“WCI Installation,” p. 24,](#) making sure the addresses do not conflict with existing WCIs.
2. Install the WCI(s) on the Tracer SC+ as described in [“WCI Installation”.](#) Use a daisy-chain configuration to install multiple WCIs.
3. Use the Tracer SC+ UI/Synchrony to enable the proper wireless networks.
4. A new network will be created for each newly installed WCI, with each WCI as coordinator of the newly created network. Allow sufficient time for all member WCIs to join the new network.
5. Start Tracer SC+ Device discovery. (Refer to Tracer SC+ Online Help for the discovery procedure.) Devices that previously existed on the wireless network do not need to be rediscovered.

A WCI has to be a network member before Tracer SC+ can discover the controller associated with the WCI. Tracer SC+ does not discover repeater WCIs.

Removing a WCI from a Network

If the other WCIs that were members of the disbanded network find an open network within radio range, they will try to join that network. To prevent that from occurring, you can remove WCIs from the network until the coordinator WCI is replaced.

Using Tracer TU

After attaching Tracer TU to a wireless device, select **Remove from Network** from the Wireless menu.

Using the WCI

To remove a member (non-coordinator) WCI from a network, do either of the following:

- Press the **WCI START** button (10–15 seconds) until the green NWK LED turns off.
Note: The same action performed on the coordinator WCI will disband the network.
- Change the rotary address on the WCI.

After the WCI is dropped from the network, the equipment managed by the associated unit controller is under the direct, local control of the unit controller.

Replacing a WCI on a Network

See "Replacing a Failed WCI," p. 72.

Moving a WCI From One Device to Another

Any time a WCI is moved from one UC to another or from a UC to a repeater, or from a repeater to a UC, the WCI should be cleared first. Before moving the WCI, set both the GRP and NET rotary addresses to 0,0 while the WCI is powered. Wait about 10 seconds for all the LEDs to flash simultaneously. This will clear any UC and network information from the WCI and allow the WCI take on a new identity.

Changing the ZigBee® Channel of the Wireless Network

If interference is suspected on an established network, the ZigBee³ channel that the WCIs are using can be changed. This change is possible without having to physically change the rotary address switches on each WCI in the network. This is done in Tracer TU under Wireless >Advanced. For information on how to do this please see the Help topic in Tracer TU titled "Changing the Channel of a Wireless Network".

Please note that most of the time interference is not the cause of poor network performance. What appears to be symptoms of interference is more often a network layout issue. It is highly recommended before changing the network channel, to inspect the network layout to make sure the coordinators are centrally located, there are no obstructions that could block the radio signal, and the WCIs are all within design limit range.

Closing the Network

To prevent WCIs from joining an open network (indicated by an illuminated OPEN_NET LED), you can close the network by using Tracer TU or the coordinator WCI.

Using Tracer TU

After attaching Tracer TU to a wireless device, select **Close Network** from the Wireless menu.

Using a WCI

To close an open network (indicated by an illuminated OPEN NET LED) so that other WCIs cannot join, push the **OPEN NET** button on the network coordinator WCI. (Pushing the OPEN NET button on an open member WCI closes just that one WCI.)

Disbanding a Network

Some rare circumstances may require disbanding the network.

Using Tracer TU

After attaching Tracer TU to the network coordinator, select **Disband Network** from the Wireless menu. As the network disbands, the NWK LEDs on all WCIs on the network respond by turning Off.

Using a WCI

Press the **START** button (for approximately 10-15 seconds) on the coordinator WCI until the yellow CRD LED and the green NWK LED turn Off. As the network disbands, the NWK LEDs on all WCIs on the network respond by turning Off.

³ ZigBee is a registered trademark of the ZigBee Alliance.



Troubleshooting and Maintenance

This section lists some common problems and their causes, lists network health indicators, and describes procedures used to maintain a facility.

WCI Does Not Join Network

Problem	Explanation/Resolution
Network closed / Not enough time allowed for joining	Give the WCI more time to join. If the network closes before the WCI has joined, re-open if necessary by pressing the OPEN NET button on another member WCI.
Wrong address	For factory addressed WCIs, verify address is correct. Verify each WCI address after installation. If sensor is installed, check for error code at sensor. Initiate network formation and resolve by exception.
No power	Ensure that: <ul style="list-style-type: none"> • The WCI is wired correctly. • The corresponding controller is wired to equipment correctly and is powered On.
Too much traffic	Try a different channel by selecting a different net address or by using Tracer TU. A better channel may be found by trial and error or by using a purchased tool such as WiSpy.
Outside of radio range or too many obstacles	Relocate WCI or add a repeater.
Defective WCI	Replace

Tracer SC+ Does Not Communicate with WCI

Problem	Explanation/Resolution
No power to the WCI	Ensure that the WCI is wired properly to the Tracer SC+
Wireless link on the Tracer SC+ not enabled	Ensure that the wireless link on the Tracer SC+ is enabled and configured to match the WCI address, and is unique within the building.
One of the devices is outside of radio range	Move network components to within radio range or break up networks to make them smaller so that all components are within radio range. Alternatively, you can add a repeater to extend the radio range.

Sensor Does Not Communicate with WCI

Problem and Code	Explanation/Resolution
Sensor is not associated with UC (E1)	<ul style="list-style-type: none"> Verify that the unit controller and WCI firmware are up to date. The configured address in the sensor does not match the dials of a UC for any WCI in the same wireless network. Re-associate the sensor with the WCI by correcting the UC address in the sensor.
Sensor has not joined the network(E2)	<ul style="list-style-type: none"> Verify that the network is open. Normal for sensor configured with GRP-NET 0-0. Verify that the sensor has the correct group (GRP) and network (NET) addresses. Verify that the sensor is within radio range. If the sensor has previously joined the network, verify that WCIs in range are powered up. Force the sensor to associate by pressing the UP arrow on WCS-SO/SCO₂ sensors, or by pressing the center button twice on all other WCSs. Otherwise, set the correct GRP and NET addresses and open the wireless network to allow the sensor to join.
Sensor drains battery current during sleep (E3)	If the error persists and batteries drain prematurely, the sensor may have defective components and need to be replaced.
Internal failure (E7)	Sensor display fails to communicate with the radio. Replace the sensor.
Wrong sensor address (E8)	The configured sensor address does not match the sensor address that is expected by the UC. Use Tracer TU to configure the UC for the quantity of sensors it should accept, if more than one. Incorrect number of sensors configured in the UC. Use Tracer TU to correct.
Duplicate sensor (E9)	Another sensor with the same configured UC address and sensor address is already associated with the UC. Resolve the duplication. This may involve waiting (up to 34 minutes) for the UC to forget the address of a failed sensor.

No Communication

Problem	Explanation/Resolution
Power loss	Communication will automatically be restored when power is restored.
Signal obstruction	Routes in the mesh network are updated every 10–30 seconds.
One of the devices is outside of radio range	Move network components to within radio range or break up networks to make smaller networks so that all components are within radio range. Alternatively, you can add a repeater to extend the radio range.
Incorrect power-up sequence	Cycle power on the controller or Tracer SC connected to the WCI.

Slow Communication

Problem	Explanation/Resolution
Duplicate unit controller BACnet Device IDs.	Make sure that every device on the network has a unique BACnet Device ID. Refer to the current version of BAS-SVX51*-EN, <i>BACnet MS/TP Wiring and Link Performance Best Practices and Troubleshooting Guide</i> .

ZigBee® and Wi-Fi Channel Information

Use the following information to help decide which ZigBee® channels to use to avoid Wi-Fi interference. Note on the diagram below that ZigBee channels 15 and 20 fit perfectly between the commonly used Wi-Fi channels 1, 6, and 11. Other ZigBee channels are also shown and their relation to Wi-Fi channels 1, 6, and 11. Also note that ZigBee channel 25 is outside of any possible Wi-Fi interference.

Note: Tracer TU now has two tools to help identify channels that may have excessive traffic. Please see *Communication History* and *Channel Quality Scan Tool* sections in this document for more information.

Figure 45. Zigbee and Wi-Fi channels alignment

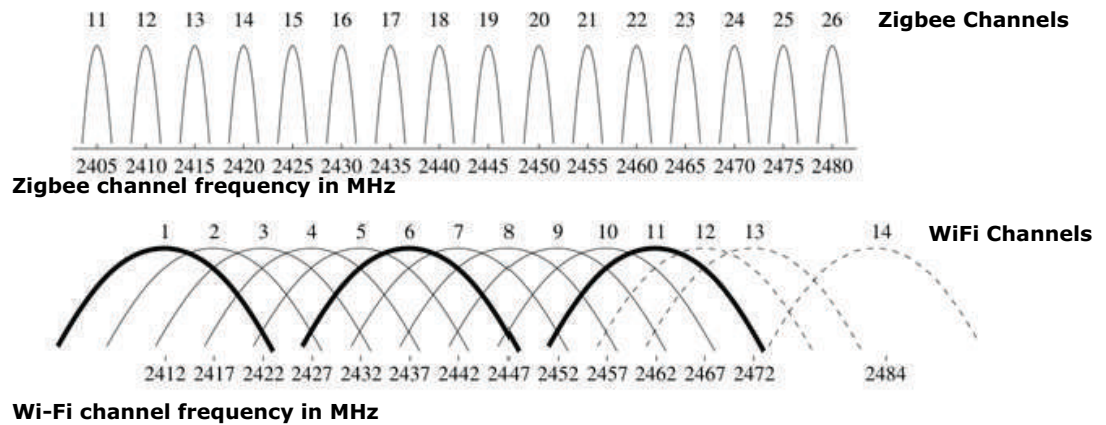

Air-Fi networks will automatically form on a channel according to their WCI NET rotary switch as show in the table below:

WCI NET rotary setting	Zigbee Channel
1	15
2	20
3	14
4	19
5	16
6	21
7	11
8	25

Other Zigbee channels not listed in table above can be selected using Tracer TU (Wireless tab > Advanced). See Tracer TU Help “Changing the Channel of a Wireless Network” for more information on how to accomplish this.

- Zigbee Channels 11-24 are 100mW. Typically about 200 feet of range.
- Zigbee Channel 25 is 50mW. Typically about 150 feet of range.
- Zigbee Channel 26 is not used by Air-Fi.

Replacing a Failed WCI

Complete the following tasks to replace a failed WCI.

⁴ ZigBee is a registered trademark of the ZigBee Alliance.

Task 1: Remove the failed WCI

Complete the following tasks to replace a failed WCI.

⚠ WARNING

Hazardous Voltage!

Failure to disconnect power before servicing could result in death or serious injury.

Disconnect all electric power, including remote disconnects before servicing. Follow proper lockout/tagout procedures to ensure the power can not be inadvertently energized. Verify that no power is present with a voltmeter.

1. Remove power from the controller that has the failed WCI wired to it.
2. Remove the WCI cover by firmly pressing the thumb tab at the bottom of the cover and pulling the cover away from the back plate.
Note: If present, remove the security screw before removing the cover.
3. Detach the 4-connector screw terminal block on the wiring harness from the receptacle on the WCI and remove the WCI.

Task 2: Install the new WCI

⚠ WARNING

Hazardous Voltage!

Failure to disconnect power before servicing could result in death or serious injury.

Disconnect all electric power, including remote disconnects before servicing. Follow proper lockout/tagout procedures to ensure the power can not be inadvertently energized. Verify that no power is present with a voltmeter.

Note: If a diagnostic occurs, an error code appears at the bottom center of the WCS display. For an explanation of error codes, see [“Sensor Does Not Communicate with WCI,” p. 71.](#)

New member (non-coordinator) WCI

1. Set (or verify if pre-addressed) the rotary address switches on the new WCI.
2. Attach the terminal block on the wiring harness to the receptacle on the new WCI and route the wires as before (through either the back plate or the bottom exit port).
3. Restore power to the controller that the WCI is installed on. Use Tracer TU to open the network (**Tools >Wireless>Open Network**) or press the OPEN NET button when connected to the coordinator or to a WCI that is already a member of the network. The new WCI should find the network and join it.

New coordinator WCI when Tracer SC is present

1. Set (or verify if pre-addressed) the rotary address switches on the new WCI.
2. Attach the terminal block on the wiring harness to the receptacle on the new WCI and route the wires as before (through either the back plate or the bottom exit port).
3. Using a USB cable, connect Tracer TU to another WCI on the network and disband the network. (See [“Disbanding a Network,” p. 69.](#))
4. If a Tracer SC is present on the network, restore power to the Tracer SC. The network will re-form itself.

New coordinator WCI when no Tracer SC is present

1. Set (or verify if pre-addressed) the rotary address switches on the new WCI.
2. Attach the terminal block on the wiring harness to the receptacle on the new WCI and route the wires as before (through either the back plate or the bottom exit port).
3. Using a USB cable, connect Tracer TU to another WCI on the network and disband the network. (See [“Disbanding a Network,” p. 69.](#))
4. Restore power to the controller on which the WCI is installed.

5. Push the START button for 5 seconds or use Tracer TU to re-form the network.

Testing WCS Signal Quality and Battery Life







To test the radio signal quality between the WCS and the WCI, and WCS battery life:

1. Press the WCS center keypad button twice.
2. Observe the radio signal quality symbol on the display and refer to “Viewing Unit Controller Operating Status,” p. 59.

Note: Additional unit controller operating status data may appear on the display. For more information, see “Viewing Unit Controller Operating Status,” p. 59.

3. Record the results in your commissioning statement.

Table 13. Testing radio signal quality between the WCS and the WCI, and WCS battery life

User action	Symbol on WCS display	Indicates...
Press the WCS center keypad button twice.		Associated but no communication with the WCI. In this situation, only the battery level and error code will appear.
		Excellent signal quality <ul style="list-style-type: none"> • Good signal margin for reliable communication. • Corresponds to a green link on the Tracer TU network health map.
		Satisfactory signal quality: <ul style="list-style-type: none"> • Adequate signal quality for reliable communication. • Corresponds to a yellow link on the Tracer TU network health map.
		Poor signal quality: <ul style="list-style-type: none"> • Unreliable communication. • Recommend moving the sensor or the WCI to a better location if the quality remains low for repeated signal tests. • Corresponds to a red link on the Tracer TU network health map.
		100–50% battery life remaining.
		50–3% battery life remaining.
		Less than 3% battery life remaining. When the remaining battery power is approximately 1%, the battery symbol will flash on the main display screen. In the test mode display screen, the empty battery symbol will not flash.

Checking Signal Quality on a Site

Follow these steps to check the signal quality on a site:

1. Power up a WCI with a 24 V transformer (user supplied).
2. Associate the WCS to a WCI of the same model that is intended for the job.

3. Place the WCI at the desired location.
4. Place or hold the WCS at the desired location.
5. Press the WCS center keypad button and observe the test symbols on the WCS display. (See “Testing WCS Signal Quality and Battery Life,” p. 74.)

Battery Information

Sensor battery type, length of life, and installation are addressed in this section.

Sensor Battery Type

NOTICE

Battery Damage!

Failure to follow instructions below could result in battery leakage and, in some cases, cause the safety release vent to open.

Do NOT attempt to recharge the batteries. The batteries are manufactured in a ready-to-use state and are NOT designed for recharging.

NOTICE

Sensor Damage!

Do not hook up the sensor to a power supply as it could result in sensor damage.

It is unlikely that you will have to replace the battery. If replacement becomes necessary, use only an Energizer L91 Ultimate Lithium AA battery or equivalent.

Sensor Battery Life

Battery life for WCS-SD, -SB, -SB/R is 15 years under normal conditions. Battery life for WCS-SO and WCS-SCO₂ is 10 years under normal conditions. If the sensor is not used for an extended period of time, do one of the following:

- Set the group and net addresses to 0,0 to place the sensor into a low-power hibernation mode.
- Remove the batteries or place an insulator between the batteries.

Notes:

- *If lithium batteries are temporarily unavailable, alkaline batteries can be used. However, alkaline battery life is very short by comparison.*
- *The battery life for a model WDS may decrease with extended LCD display activity.*

Battery Installation

⚠ WARNING

Risk of Injury with Batteries!

Failure to follow handling instructions below could result in severe injury.

- **Do NOT install batteries backwards.**
- **Do NOT disassemble, charge, or expose batteries to water, fire, or high temperature.**
- **Keep batteries away from children. If swallowed, contact your local poison control center immediately.**

1. Observe the polarity indicators that are molded into the cover.
2. Install two batteries (of the type specified in “Sensor Battery Type,” p. 75) in the battery-holding slot that is molded into the sensor cover.

The sensor has been designed to prevent damage if the batteries are installed backwards, to reduce the potential for injury.

Manual Association Process

If an association was previously established between a WCI and a sensor and needs to be re-established, the manual association process may be used. The process for the WCS-SO/SCO₂ differs slightly from other sensors.

WCS-SO, -SCO₂, -SB/R

To activate this process from a blank screen or an error screen, push the UP arrow on the WCS keypad. The association process will be repeated as the display shows rotating segments.

Note: *Pressing the UP arrow will repeat the joining/associating process from the last point of failure. In other words, if there is an E2 (not in a network), the sensor will start by looking for an open network to join. If there is an E1, the sensor will look for a unit. If there is an E8 or E9, the sensor will request association with the unit. The process continues until a step fails or the unit provides system data to display.*

WCS-SB/SD

To activate this process, push the center button twice on the WCS keypad. The association process will be repeated.

Note: *Pressing the center button twice will repeat the joining/associating process from the last point of failure. In other words, if there is an E2 (not in a network), the sensor will start by looking for an open network to join. If there is an E1, the sensor will look for a unit. If there is an E8 or E9, the sensor will request association with the unit. The process continues until a step fails or the unit provides system data to display.*

Disassociation

If any address—group/net, unit controller, or sensor # — is changed in a sensor that is associated with a controller, the sensor will transmit a request for the controller to disassociate the sensor immediately.

If a controller does not receive any messages from a sensor for 34 minutes, it will disassociate that sensor. Only after a sensor has been disassociated can the controller accept association from a replacement sensor.

Replacing a Failed WCS

To replace a failed WCS:

1. Remove failed sensor from the wall.
2. Disassociate the sensor from the unit controller by using one of the three methods described below. (A. is the recommended way to disassociate the sensor when possible)
 - a. If the sensor is still communicating with the unit controller, change any part of the sensor address (GRP, NET, UC, SENSOR#). The sensor will immediately send a request to the unit controller to disassociate, and it will display E1. Proceed to [Step 3](#). (If in doubt that this method worked, or the sensor is not communicating with the unit controller use method B).
 - b. Remove the batteries from the failed sensor and let the association between old unit controller and sensor expire on it's own. Proceed to [Step 3](#).

Note: *If you use this method to disassociate the old sensor, an E9 error code may display on the new sensor. This error code will be displayed for 34 minutes. After 34 minutes, the error code will clear and the new sensor will automatically associate to the unit controller.*
 - c. An alternative method to [Step 2b](#) will speed up the disassociating process.
 1. Set the UC rotary address to 000 and wait 30 seconds.
 2. Power down UC and set UC address to correct setting.
 3. Restore power to UC. Wait for one minute before attempting to associate the sensor.
 4. Confirm network is open.
 5. Confirm WCS address settings are correct (GRP, NET, UC, Sensor#).
 6. Press center button on sensor twice to force transmission. Sensor should join the network and associate with the UC.
3. On the new sensor, set the address and configuration to match the original sensor.

4. Open the network using Tracer TU or by pressing the Open Net button on the WCI coordinator.
5. For WCS-SB/SD sensors, press the center button twice to force the sensor to join the network and associate to the unit controller. For WCS-SO, -SCO₂, -SB/R sensors, press the UP arrow once to force the sensor to join the network and associate to the unit controller. This process may need to be repeated a few times.

Sensor Output Power Level

The maximum output power level of a wireless sensor set is controlled by software and restricted by channel of operation and agency requirements per country or region. The sensor has a default maximum power level of 10 mW, but the WCI determines the ultimate output power level of the sensor.

In North and South America the sensor will change to 100 mW after joining the network.

Cleaning the Sensor

You can clean the sensor by applying glass cleaner to a soft, non-abrasive cloth, and gently wiping the face, including the buttons and LCD display. Use of a pre-moistened towelette designed for lens or screen cleaning is also acceptable.

NOTICE

Sensor Damage!

Do not spray glass cleaner or any other solution directly on the sensor as it could damage it.

While you clean it, avoid inadvertent pressing of the keypad buttons on the sensor, as this may result in an unwanted timed override or settings change.



Using the Tracer® TU Service Tool with a Wireless Network

To monitor, troubleshoot, or make modifications to devices on a wireless network, the Tracer TU service tool must be connected to a device that is a member of that network. This appendix describes that process and how to access wireless network management information and functions.

For instructions on using Tracer TU to make changes to a wireless network. (See “[Modifying an Air-Fi® Network](#),” p. 68.)

Requirements for Joining a Wireless Network

The requirements for joining Tracer TU to a wireless network are:

- Tracer TU version V8.2 or higher
- The Tracer TU Communications Adapter (wireless) connected to the service tool laptop.

Note: For instructions on Tracer TU Communications Adapter Wired/Wireless installation and best practices, see the current version of X39641157.

- A user ID and password, if the network includes a Tracer SC.

Note: All wireless features are available through all connection types as of Tracer TU V8.3.

Joining Tracer TU to a Wireless Network

Use the Wireless Network Utilities dialog box to initiate a wireless connection to a network and then connect to a specific device in the selected network.

1. Locate the TU Adapter within radio range of any WCI that is a network member.
2. Launch Tracer TU with the Tracer TU Wireless Communication Adapter connected to your laptop.

The Startup Task Panel appears as shown in the following figure.

Figure 46. Tracer TU startup task panel

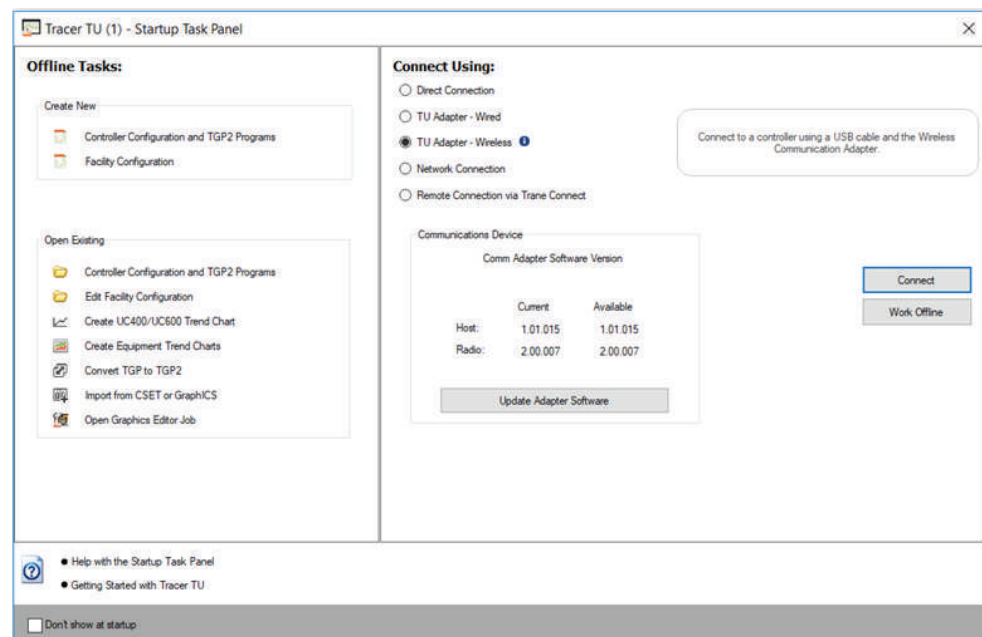

3. Select **TU Adapter - Wireless** and then click **Connect**.

The Wireless Network Utilities dialog box appears as shown in the following figure. It shows the group and subnetwork numbers (which correspond to WCI address settings) and the signal strength

for all existing wireless networks within radio range of Tracer TU. A closed padlock icon indicates that a Tracer SC login is required. An open padlock icon indicates that no Tracer SC login is required.

Figure 47. Initial network utilities dialog box

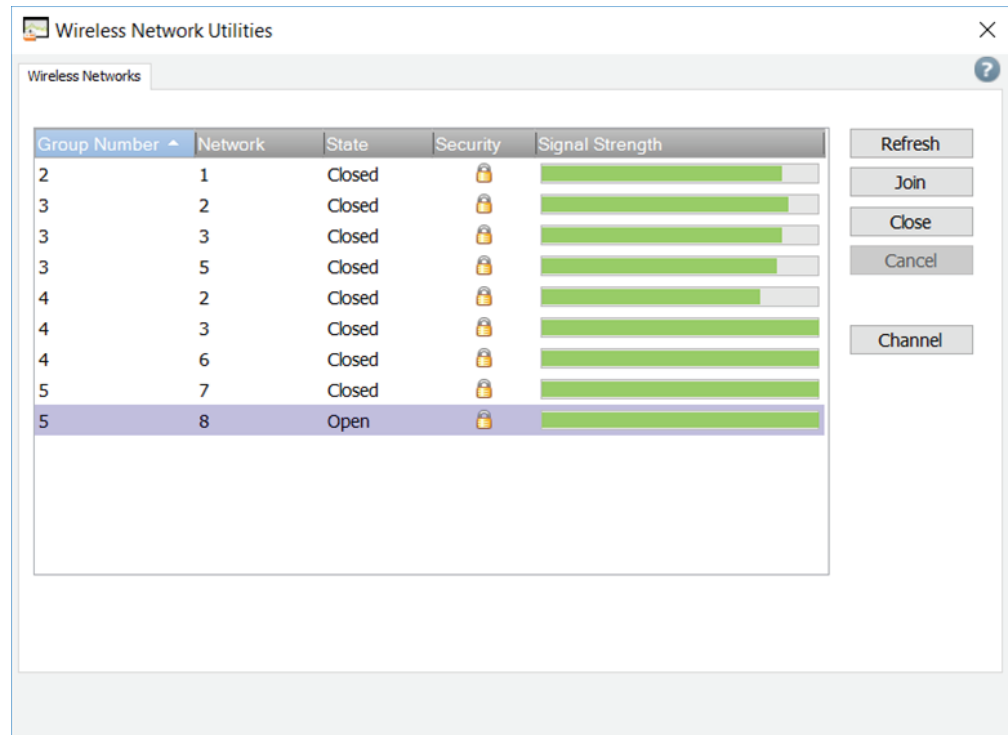

4. Select the network you want Tracer TU to join and click **Join**.

Note: Starting with Tracer TU version 11.0 you will be required to open the Air-Fi® network before joining. The State column shows which networks are open.

Note: Tracer TU can join only one network at a time.

- If a Tracer SC is present on the network, a log-in prompt appears. Enter your Tracer SC user-ID and password. After log-in, the **Wireless Network Utilities** dialog box appears as shown in the next figure.
- If no Tracer SC is present on the network, the dialog box shown in the next figure appears without the need to log in.

In the Security column, the lock icon is replaced by a key icon to identify the network that Tracer TU has joined, and two additional tabs appear on the screen.

Figure 48. Wireless network utilities dialog box after joining the network

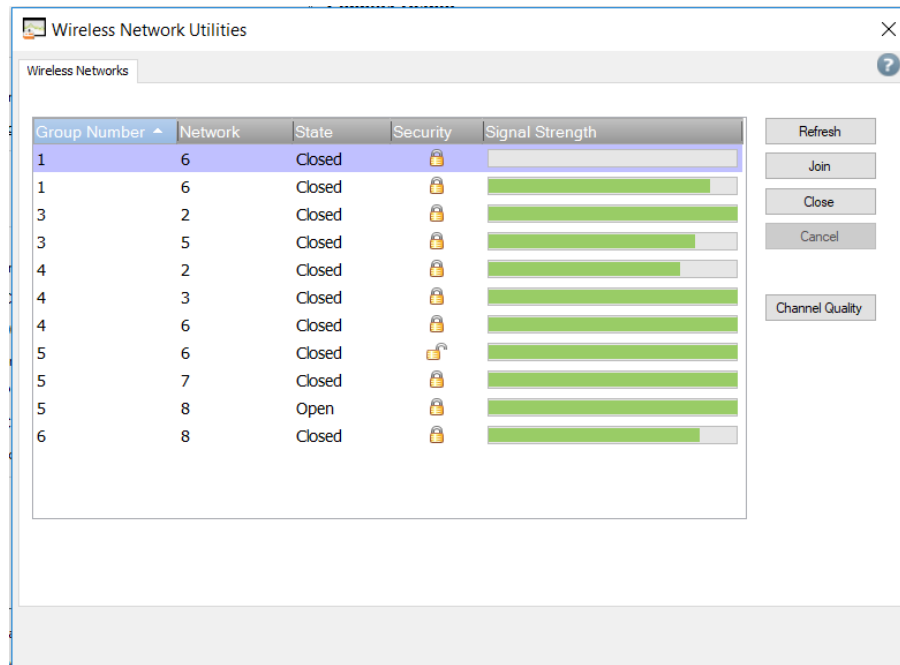

Managing a Wireless Network and Devices

After communication has been established between Tracer TU and a wireless network, you can manage the network and the devices on it by connecting to a device on the network.

Connecting to a Device

To connect to a device:

1. From the Wireless Network Utilities screen, select the **Network Devices** tab as shown in the following figure.

Figure 49. Network Devices tab

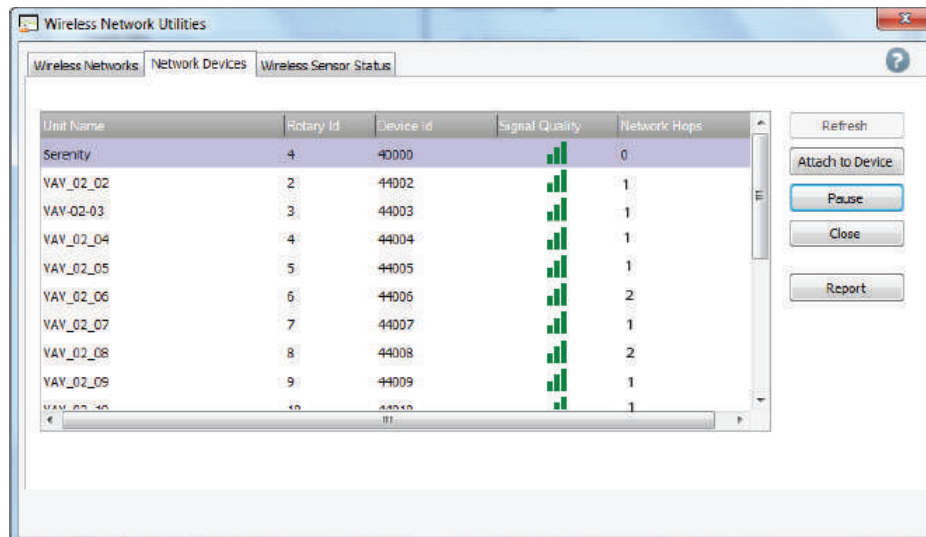

2. Select a device from the list of network devices and click **Attach to Device**. The Unit Summary

screen for the selected device appears and Tracer TU capabilities are available.

Figure 50. Connected device: Unit Summary screen

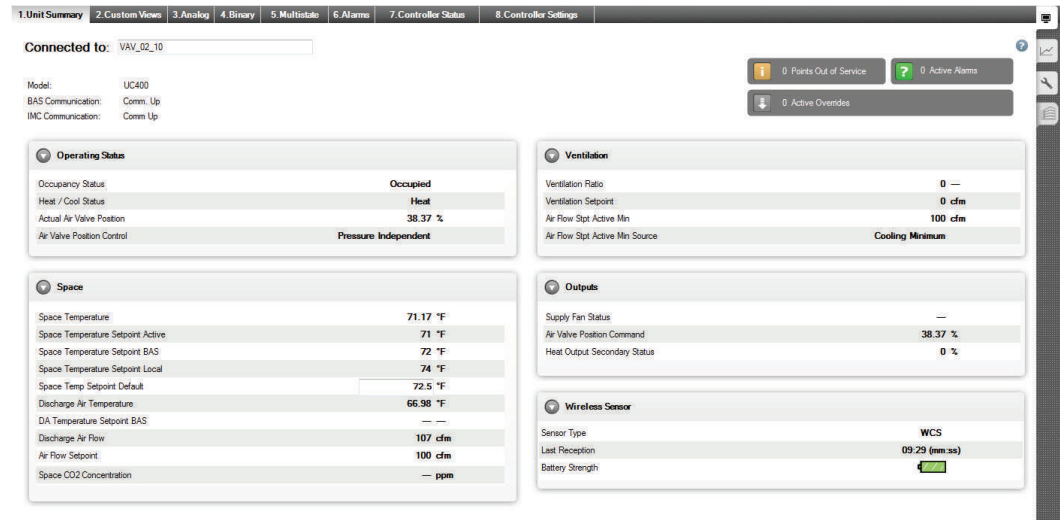

The Wireless Menu

After Tracer TU is connected to a device, a Wireless submenu becomes available for wireless network management. To access the menu, select **Wireless** from the toolbar.

The Wireless submenu options depend on the type of connection, as shown in the following figures. Each of the options are described in this section.

Figure 51. Wireless connection to a Tracer SC/SC+ through a TU Adapter

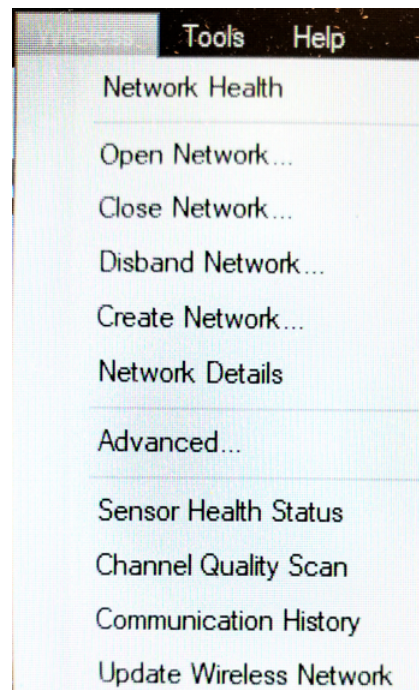
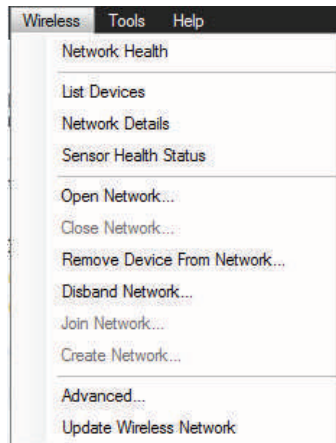
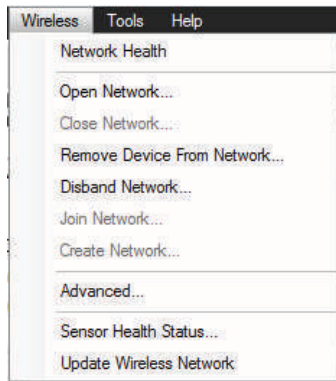

Figure 52. Wireless connection to a UC through a TU Adapter

Figure 53. Connection to a UC through a connection type other than TU Adapter

Network Health

Displays the Wireless Network Summary Report, shown in the following figure, which presents unit activity information including:

- The number of times Tracer SC has attempted to communicate with each device
- The failure rate
- Link status and signal quality
- The amount of time it took for Tracer SC to get a response to a comm request from each device

Note: You can also access the **Wireless Network Summary Report** by clicking **Report** on the **Network Devices** tab.

Figure 54. Wireless Network Summary Report

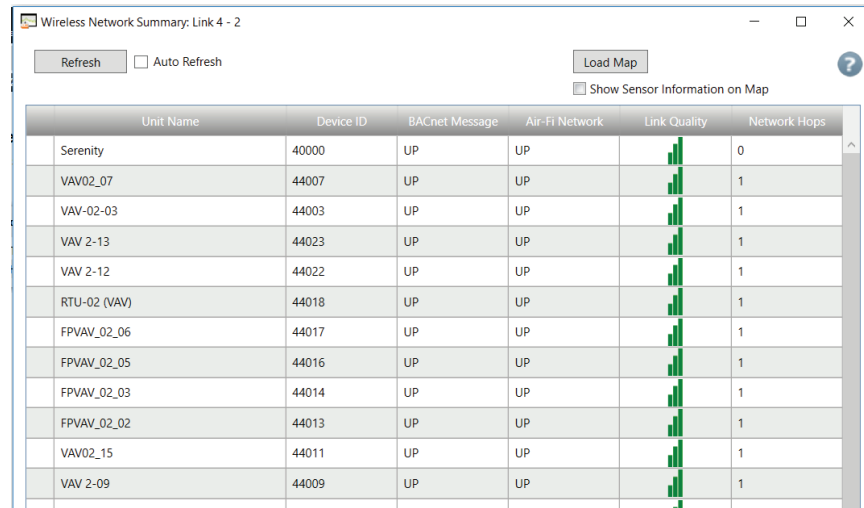

Unit Name	Device ID	BACnet Message	Air-Fi Network	Link Quality	Network Hops
Serenity	40000	UP	UP		0
VAV02_07	44007	UP	UP		1
VAV-02-03	44003	UP	UP		1
VAV 2-13	44023	UP	UP		1
VAV 2-12	44022	UP	UP		1
RTU-02 (VAV)	44018	UP	UP		1
FPVAV_02_06	44017	UP	UP		1
FPVAV_02_05	44016	UP	UP		1
FPVAV_02_03	44014	UP	UP		1
FPVAV_02_02	44013	UP	UP		1
VAV02_15	44011	UP	UP		1
VAV 2-09	44009	UP	UP		1

Click **Load Map** to view a graphical representation or "map" of the network showing its structure and signal quality. The following figure shows an example of a network map.

Figure 55. Graphical network map

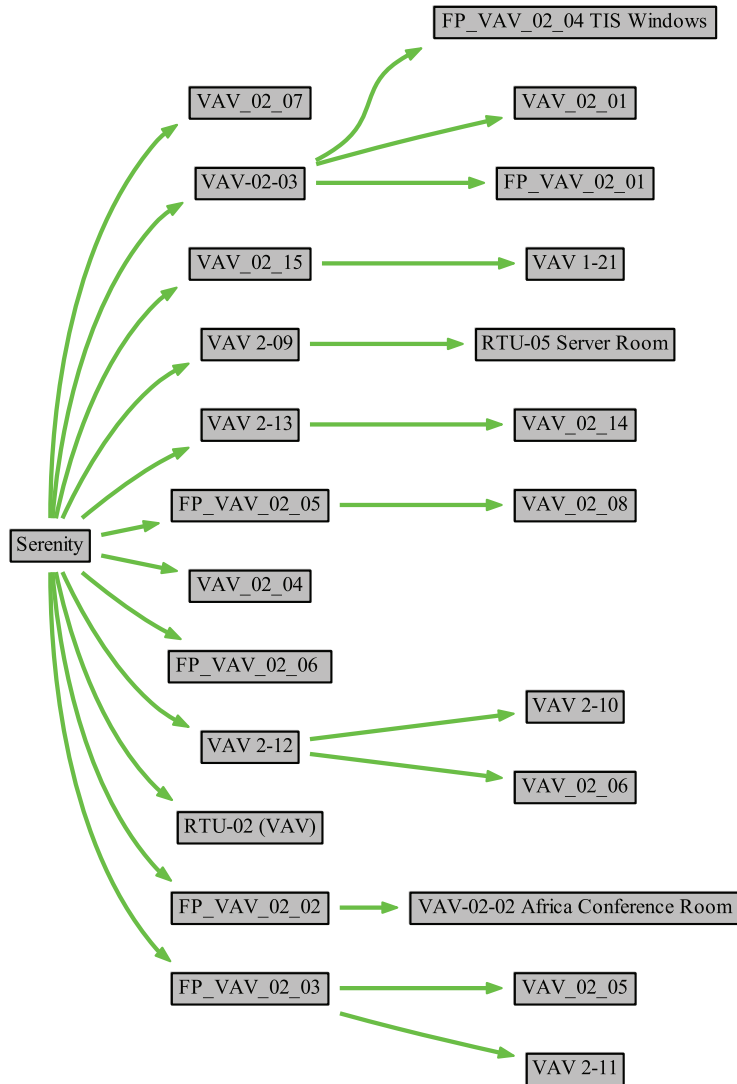

In addition, if you select the **Show Sensor Information on Map** check box, sensor details are included in the map as shown here (see "Wireless Network Map Diagram" in Tracer TU Help):

Figure 56. Sensor information displayed on the network map

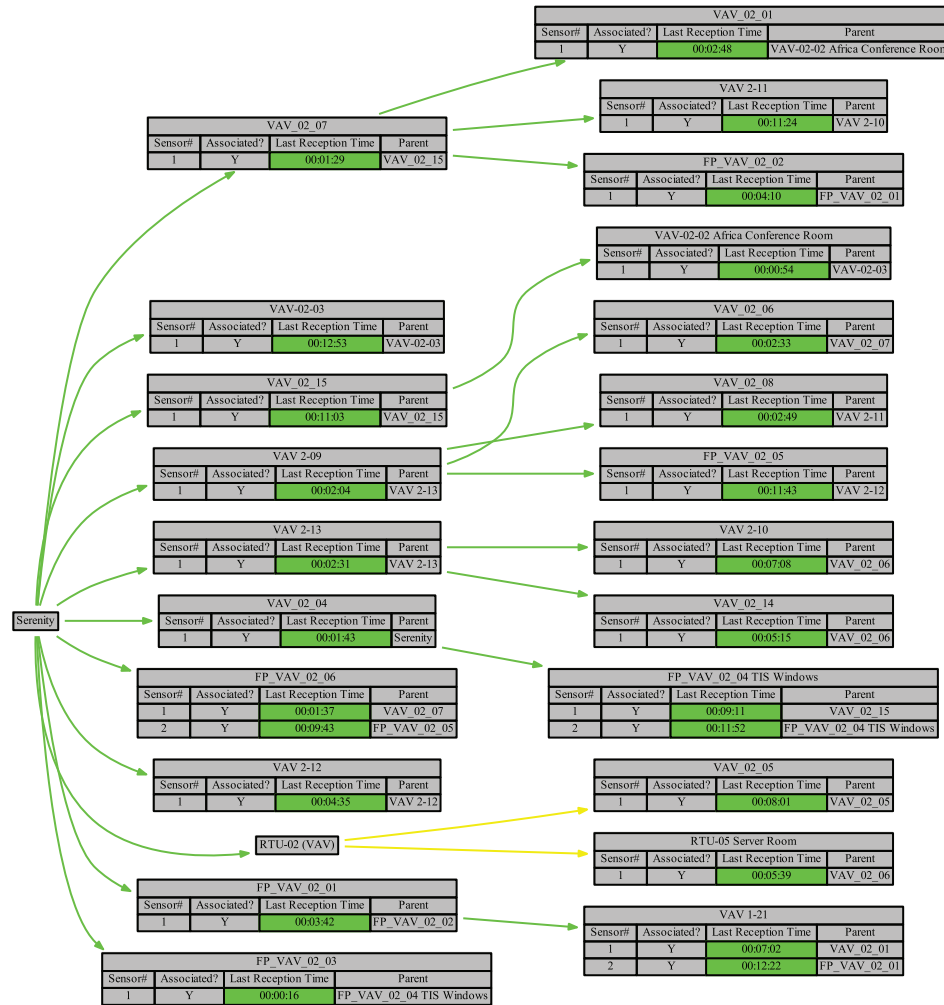

List Devices

This Tools menu option provides an alternate way to view the Network Devices tab (see Figure 4). (This option is available only when you connect to the network through the Tracer TU Wireless Adapter.)

Network Details

This option opens the Network Details tab on the Wireless Network Utilities dialog box. As its name suggests, it provides Tracer SC information if a Tracer SC is present and network status, the channel used, and the PAN ID.

Figure 57. The Network Details tab

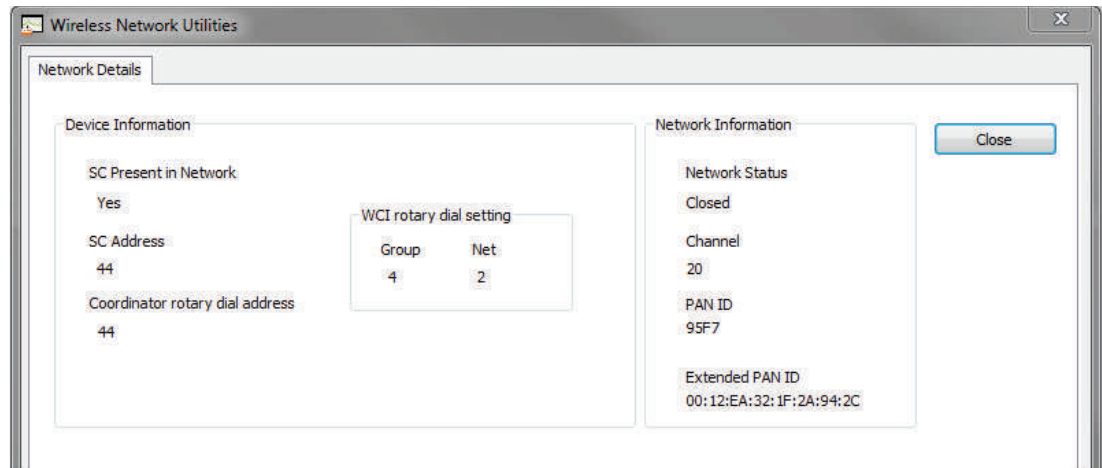

Sensor Health Status

This Tools menu option provides an alternate way to view the Wireless Sensor Status tab shown in the following figure.

Figure 58. Wireless Sensor Status tab

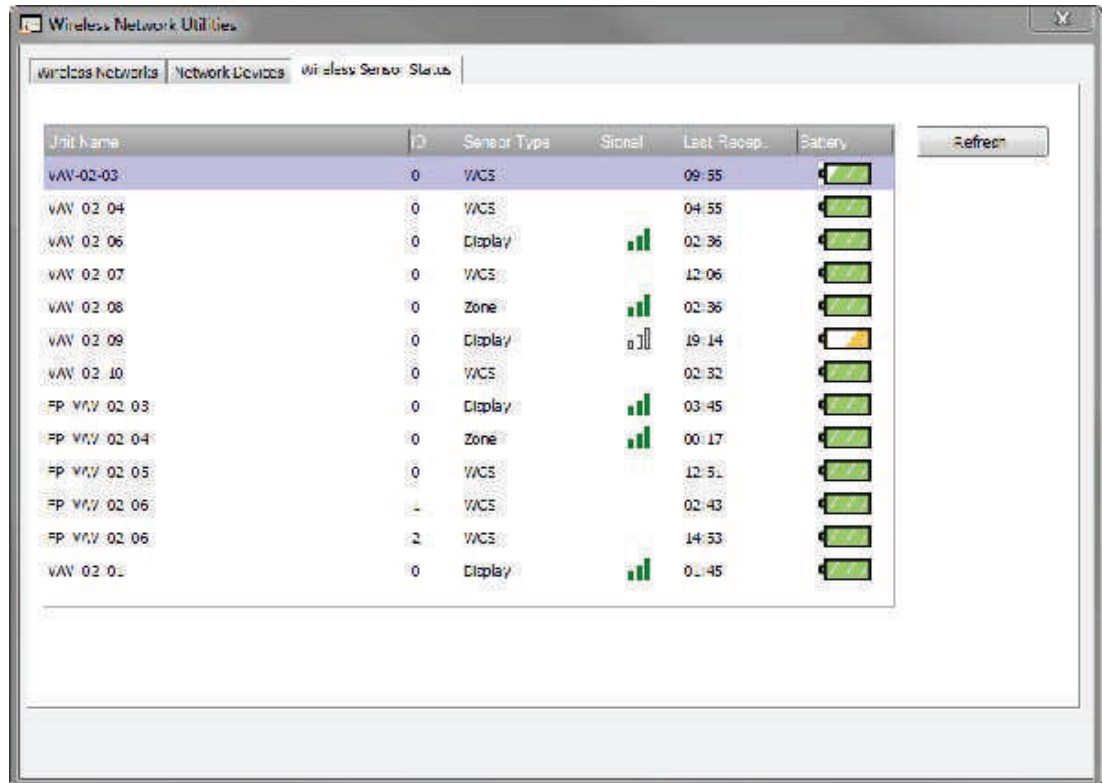

Open Network

Select this Tools menu option to allow a new member to join. Any WCI with a correct rotary address setting that is located within radio range of the open network will join the network. (Similar to OPEN_NET button on WCI.)

Close Network

Select this Tools menu option to prevent new members from joining the network.

Remove Device From Network

Select this Tools menu option to remove the WCI and its associated unit controller to which Tracer TU is currently connected from the wireless network.

Disband Network

Select this Tools menu option to disband the network. Tracer TU must be attached to the network coordinator.

Join Network

Select this Tools menu option to allow the WCI to join the network. (Appears when you are connecting to a member WCI. It is grayed out if you have already joined the network.)

Create Network

Select this Tools menu option to create a new network in which the attached device will be network coordinator. Typically, used for a unit controller that will be network coordinator when no Tracer SC is present.

Advanced

Select this Tools menu option to display the Advanced tab. Examples are shown in the next two figures.

Figure 59. Advanced tab: When connected to a unit controller with associated sensors

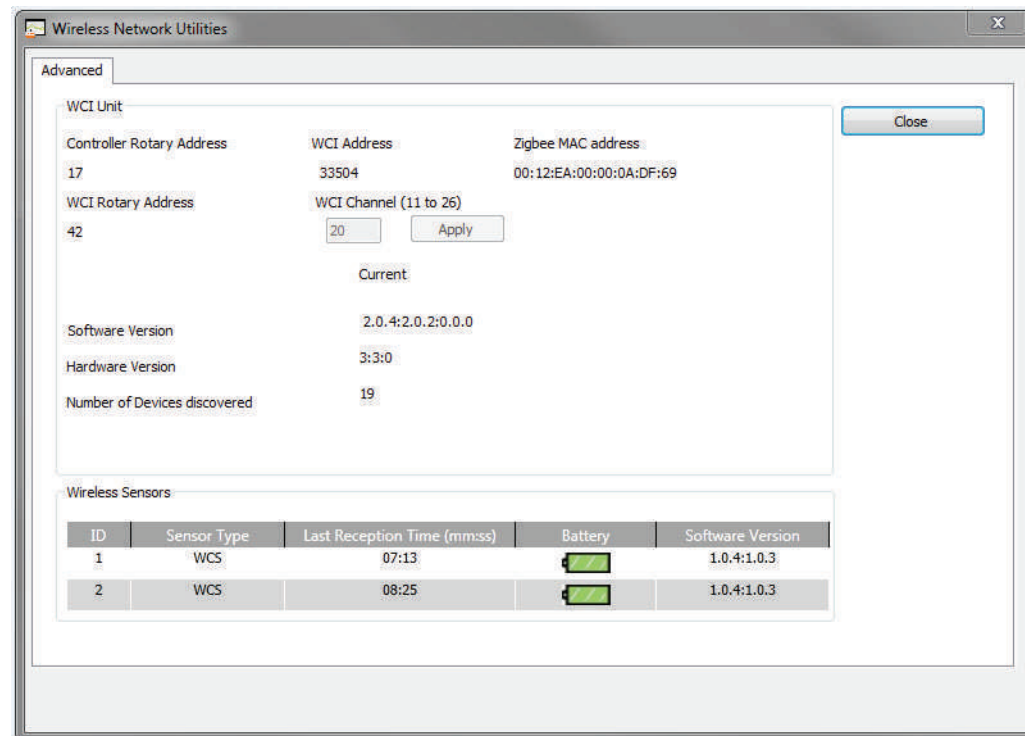

Use the following Advanced tab to change the network channel on all WCI and sensors in the network. This feature is useful when changing the network channel to avoid interference with Wi-Fi or other Zigbee devices. See **“Changing the Channel of a Wireless Network”** in the *Tracer TU Help for Programmable Controllers* for the correct procedure.

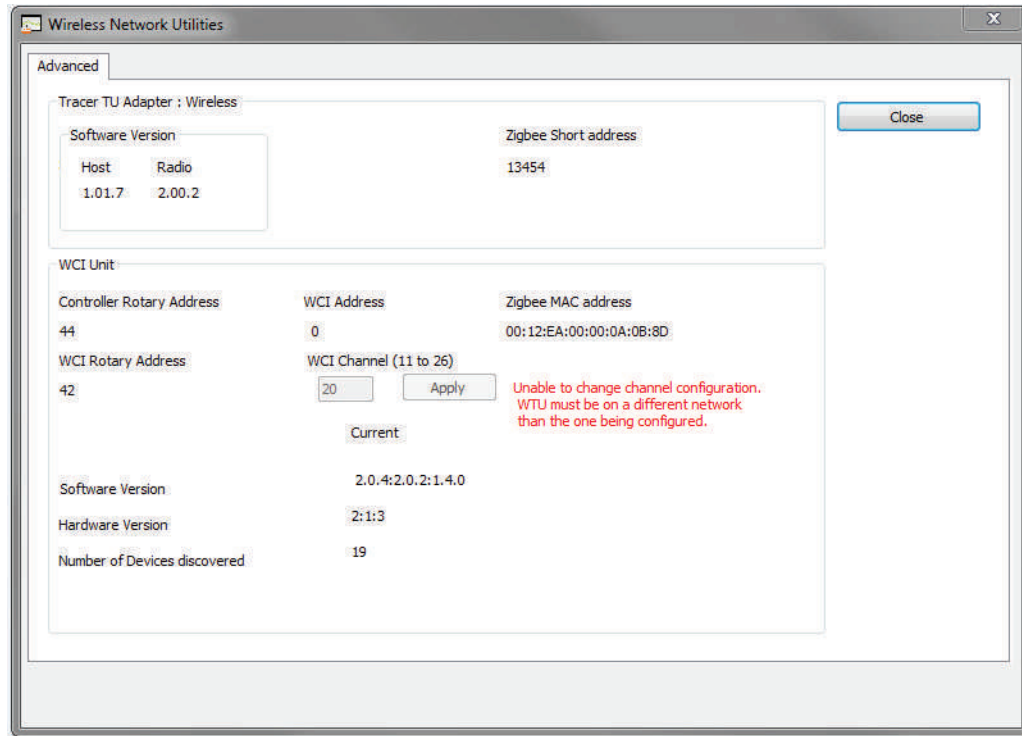
Figure 60. Advanced tab: Connected to a Tracer SC

Update Wireless Networks

Select this tool to update firmware on all devices on a wireless network. All WCIs and/or wireless sensors will be updated with an automated process.

Note: If you have repeaters that are version 1, see HUB article #110060 “How do you update firmware on a WCI repeater?”

Wireless Sensor Setup

This subsection explains two common situations you may encounter during wireless sensor setup.

Disabling a Wireless Sensor when a Wired Sensor is Connected to the Unit Controller

If a unit controller’s WCI is a sensor receiver, the wireless sensor is detected and the necessary references are created automatically. The Enable Wireless Space Sensor setting in the Wireless Sensor Configuration group box on the Controller Settings screen is enabled (selected) by default.

However, if a wired sensor is connected to the unit controller, and a wireless sensor is within range, the wireless sensor has priority and the unit controller may use the wireless sensor even though a sensor is wired to the unit controller. In such a case, you must de-select the Enable Wireless Space Sensor setting in the Wireless Sensor Configuration group box on the Controller Settings screen so that the wireless sensor is disabled from use by the unit controller and wired sensor is used instead. (Also see “**Disassociating a Wireless Sensor From a Controller**” in the *Tracer TU for Programmable Controllers Help*.)

It is also possible to disable only the wireless humidity sensor. This option would be chosen in cases where a wireless space sensor is used in conjunction with a wired humidity sensor. To disable the wireless humidity sensor de-select the Enable Wireless Humidity Sensor setting in the Wireless Sensor Configuration group box on the Controller Settings screen.

Multiple WCS Installation Setup

Setup is required in Tracer TU if multiple wireless sensors are installed on a controller. To set up a controller for multiple sensors, connect to TU and navigate to the Wireless Sensor Configuration box on

the Controller Settings screen. Using the drop-down menu, select the number of sensors that are to be associated with the controller.

Figure 61. Setting up Tracer TU for multiple wireless sensors

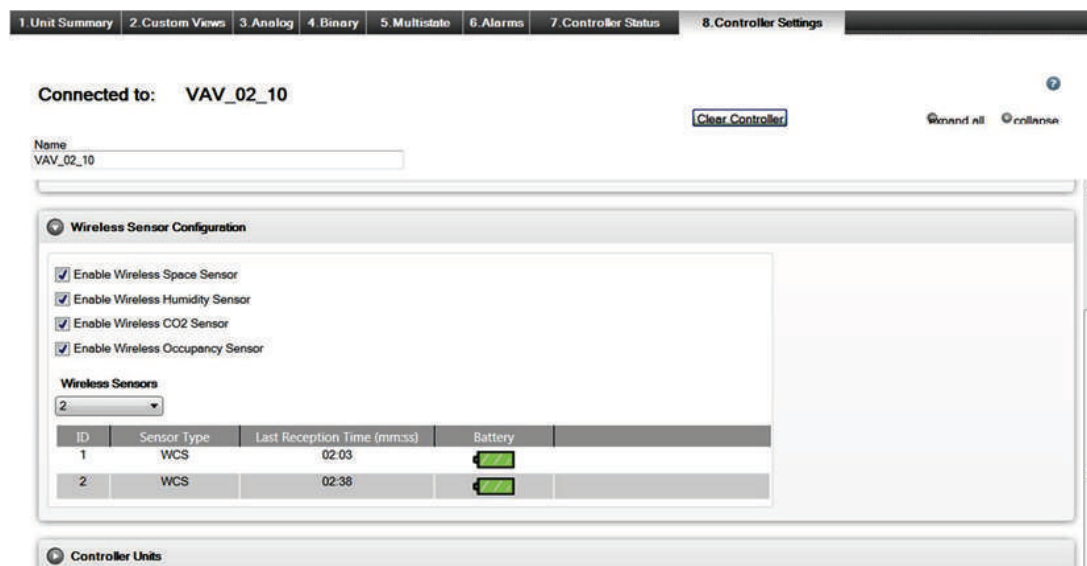

Default Sensor Values for Trane® Standard Programs

If multiple sensors are associated with a controller that has a Trane® standard program, the controller will automatically use the following values:

- **Space Temperature Local:** This point will automatically use the average space temperature value from all associated sensors.
- **Space Humidity Local:** This point will automatically use the average humidity value from all associated sensors.

Note: If a sensor value does not exist or is not valid, it will not be included in the average calculation.

- **Space CO₂ Concentration Level:** This point will automatically use the maximum CO₂ value from all associated sensors.
- **Occupancy input:** This point will show occupied if any associated sensor detects motion.
- **Cool Setpoint, Heat Setpoint, System Mode, Fan Mode, Timed Override Mode, Air Flow Override, and Battery Strength:**

All user inputs from multiple associated sensors automatically follow a round-robin sequence where the controller uses the value from the sensor that has transmitted most recently.

Referencing Individual Sensors

On the Controller Settings tab, under Wireless Sensor Configuration as shown in figure below, when multiple sensors are desired and the Enable Wireless Space Sensor box is checked, the Analog Input point Space Temperature Local will automatically use the reference wci.spaceTemp. The reference wci.spaceTemp will always average all wireless space sensors that are associated to the controller and display the average value in Space Temperature Local.

However, if using multiple sensors and the Enable Wireless Space Sensor box is unchecked, you can reference an individual sensor to Space Temperature Local by changing the reference from wci.spaceTemp to the new sensor's reference, such as wci.sensors.1.spaceTemp. This allows for the individual values to be displayed on graphics or used in custom TGP2 programs.

Note: If you have multiple sensors and are creating points and references to see the individual values, you must uncheck the Enable Wireless Space Sensor box. If you don't uncheck this box, the newly created references will be replaced by default references when the UC cycles power.

Using the Tracer® TU Service Tool with a Wireless Network

Note: If using BACnet references to share Space Temp Local or Space Temperature Setpoint Local, the Enable Wireless Space Sensors box must be unchecked or the reference will revert to wci.spaceTemp or wci.coolSetpoint on a power cycle or reboot. The same applies to humidity, CO₂ and Occupancy.

Other types of sensors can be set up in a similar manner:

- The Enable Wireless Humidity Sensor check box works the same as the Enable Wireless Space Sensors box described above. Selecting the check box provides the average humidity of all associated humidity sensors, which is displayed in Space Humidity Local. If the box is not selected, you can reference an individual sensor.
- Selecting the Enable Wireless CO₂ Sensor check box gives the maximum value of all associated wireless CO₂ sensors, which is displayed in Space CO₂ Concentration Local. If the box is not checked, you can reference an individual CO₂ sensor.
- If the Enable Wireless Occupancy Sensor check box is checked, the controller will go occupied when any occupancy sensor detects motion. The binary value is displayed in Occupancy Input on the Binary screen. If the box is unchecked, individual sensors can be referenced.

When using multiple sensors, you must create additional points in the UC to see these values in both Tracer TU and the Tracer SC. To reference individual values, navigate to the Point Configuration tab of an existing or newly created point (see the “Creating a New Point” topic in the “Configuring and Managing Points” section of the *Tracer TU Help for Programmable Controllers*). Use the Point Configuration tab shown in [Figure 62, p. 90](#) and the Reference dialog box drop-down as shown in [Figure 63, p. 91](#) to create the references.

Figure 62. Point Configuration Tab — Analog Input Properties dialog box

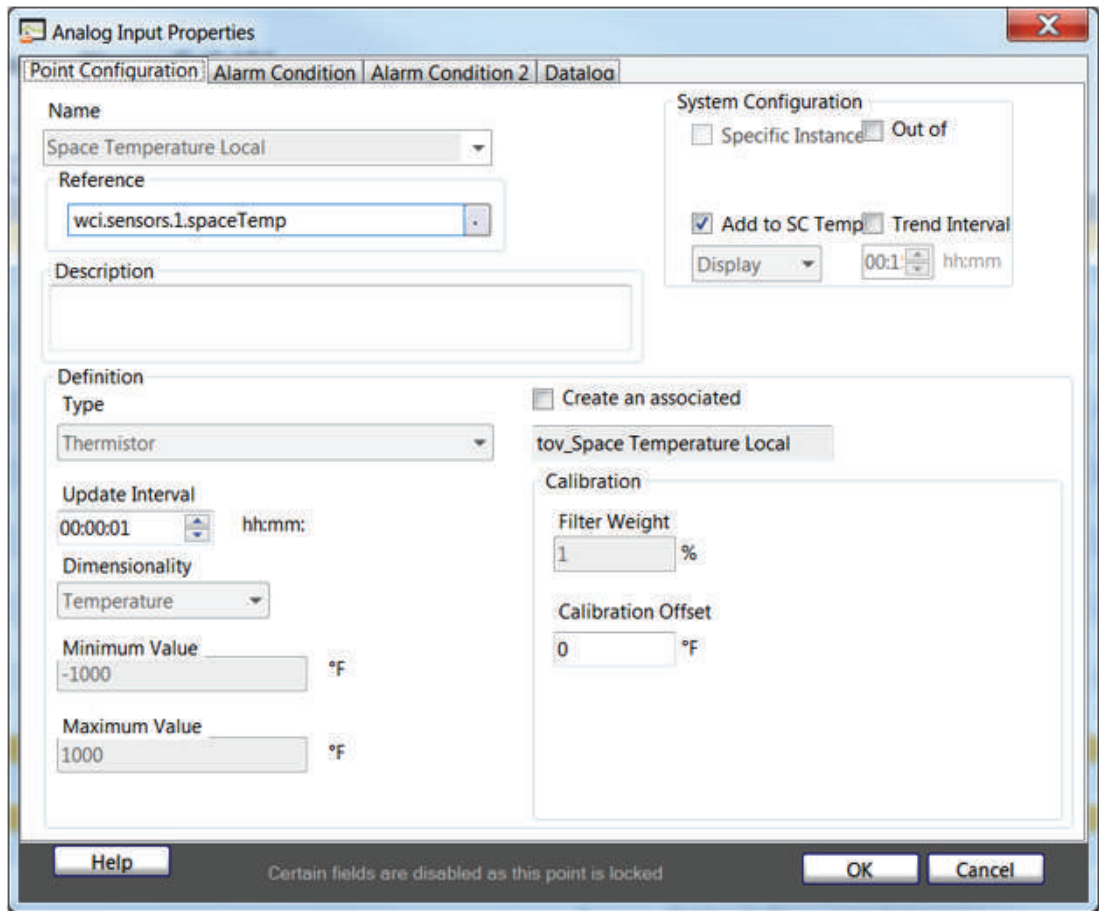

The screenshot shows the 'Analog Input Properties' dialog box with the 'Point Configuration' tab selected. The 'Name' field is set to 'Space Temperature Local' and the 'Reference' field is 'wci.sensors.1.spaceTemp'. The 'Definition' section shows 'Type' as 'Thermistor', 'Update Interval' as '00:00:01', and 'Dimensionality' as 'Temperature'. The 'Minimum Value' is '-1000 °F' and the 'Maximum Value' is '1000 °F'. The 'System Configuration' section has 'Add to SC Temp' checked and 'Trend Interval' set to '00:1'. The 'Calibration' section shows 'Filter Weight' as '1 %' and 'Calibration Offset' as '0 °F'. At the bottom, there are 'Help', 'OK', and 'Cancel' buttons. A status bar at the bottom indicates 'Certain fields are disabled as this point is locked'.

Figure 63. Reference dialog box

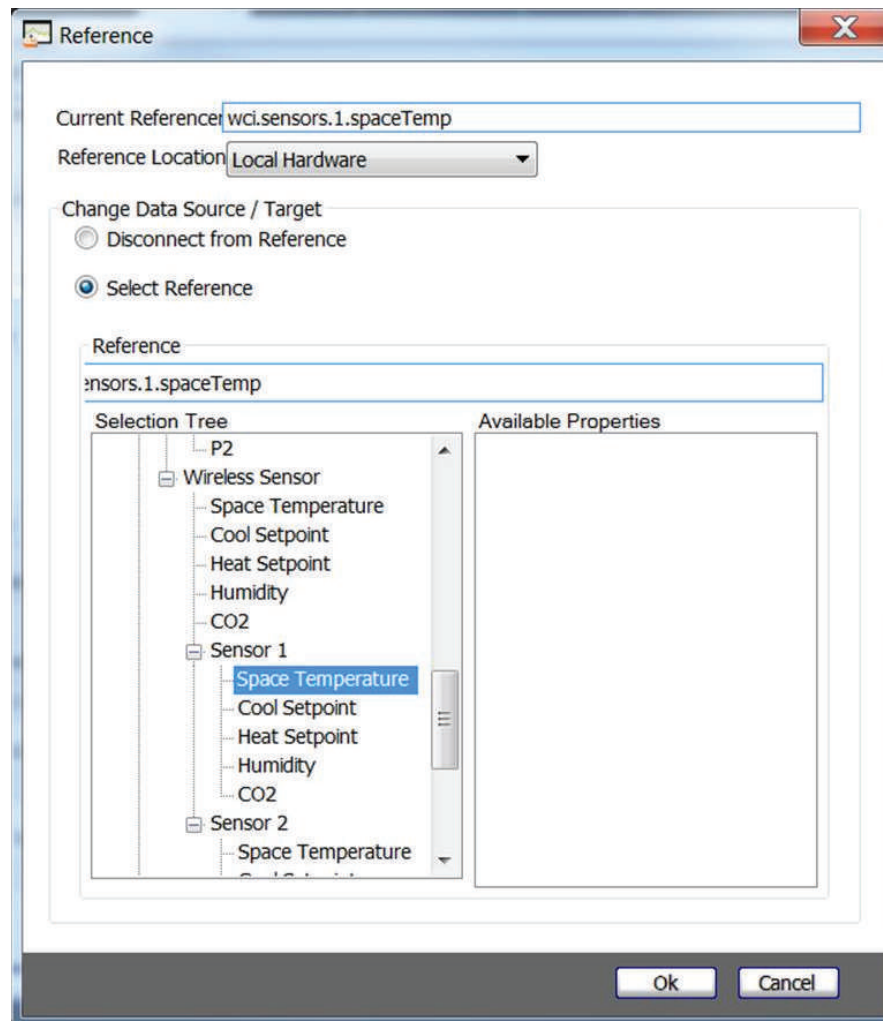

BCI/BCI2 Point and Reference Limitations

It is not possible to create points or references in any BCI/BCI2. This section explains considerations to keep in mind about the following points:

- **Space Temperature**

If using a BCI/BCI2 with multiple sensors, you will not be able to see the individual temperature values from the WCS. You will only see the average Space Temperature reported as the Space Temperature Active. BCI/BCI2s do not allow additional points to be created to read the individual sensor values.

- **Space Temperature Setpoint**

- In both BCI-R/BCI2-Rs and BCI-I/BCI2s, the space setpoint is the value of the last change in setpoint if more than one WCS is used.
- If you do not wish a WCS to provide a setpoint change, do not configure the sensor for setpoint control.
- The BCI-R/BCI2-R will only use Air-Fi sensor values if in BAS Control. To put BCI-R/BCI2-R in BAS Control you put BO-1 System Control Command point into BAS Control and In Service.
 - BCI-R/BCI2-R
 - Space Setpoints BCI-R/BCI2-R using Air-Fi with Occupied Offset in Service
 - Cooling Setpoint Active = Last change in setpoint from Air-Fi sensor + Offset



Using the Tracer® TU Service Tool with a Wireless Network

- Heating Setpoint = Cooling Setpoint Active - 2°F (1.11°C)
- Space Setpoints BCI-R/BCI2-R using Air-Fi with Occupied Offset out of service
 - Cooling Setpoint Active = Last change in setpoint from Air-Fi sensor
 - Heating Setpoint = Cooling Setpoint Active - 2°F (1.11°C)
- BCI-I/BCI2-I
 - Space Setpoints BCI-I/BCI2-I using Air-Fi with Occupied Offset in service:
 - Cooling Setpoint Active = Last change in setpoint from Air-Fi sensor + offset
 - Heating Setpoint = Last change in setpoint from Air-Fi sensor + offset
 - Space Setpoints BCI-I/BCI2-I using Air-Fi with Occupied Offset out of service
 - Cooling Setpoint Active = Last change in setpoint from Air-Fi sensor
 - Heating Setpoint = Local Keypad Setpoint.
- **Space Humidity**
 - BCI-R/BCI2-R

To see humidity, the unit must have the ability to dehumidify. Only units that support dehumidification can support the wireless humidity module or a BCI-R/BCI2-R with firmware version 7.0 and above automatically creates a humidity point. See the *BACnet Communications Interface (BCI-R) Integration Guide* (BAS-SVP09*-EN), to determine if the unit will support the humidity module and populate Space Humidity Active AI-16 with the value.
 - BCI-I/BCI2-I

All IntelliPak units support the humidity module.
- **Space CO₂**
 - BCI-R/BCI2-R are capable of supporting the WCS-SCO₂ sensor, but you must have Demand Control Ventilation enabled in order for the value to be displayed. Space CO₂ concentration level will be reported via AI-32, Space CO₂ Concentration Active. If multiple sensors are associated to a UC only the highest CO₂ value will be used.
 - To enable Demand Control Ventillation the following needs to be set up:
 1. RTEM economizer module installed.
 2. The front end cannot be controlling the OA damper.
 3. AO1 put out of service.
 4. B07 put out of service.
 5. AO16 put out of service.
 6. There must be a valid CO₂ reading.
 - BCI-I/BCI2-I does not support the WCS-SCO₂ sensor. However, you can create a CO₂ Global Reference in SC from another unit controller that is using WCS-SCO₂. The Global Reference must write the CO₂ value into Analog Output instance 18 "Space CO₂ Concentration BAS" on the BCI-I/BCI2-I. The point is then taken out of service.
- **Motion Sensor (Occupancy)**
 - BCI-R/BCI2-R (both CV and VAV types) supports WCS-SO and WCS-SCO₂ sensors with some limitations (See following table). If multiple sensors are used the space will go occupied when any associated sensor detects motion.
 - With the introduction of the Air-Fi CO₂/Occupancy sensor, the BCI-R/BCI2-R controller now supports 3 sources for Occupancy (See [Table 14, p. 93](#)):
 - Occupancy Request (MO-7)
 - Air-Fi Occupancy Sensor (wci.occupancyInput)
 - Local Occupancy Input (RTRM J6-12 signal, J6-11 common)

Above is the priority order that is used by the controller in case multiple sources are active. The BCI-R/BCI2-R arbitrates the multiple sources and then communicates the appropriate

occupancy value to the ReliaTel controller. The appropriate setpoints and fan mode are then used for the equipment control.

- To enable Air-Fi wireless occupancy in BCI-R/BCI2-R, you must put “Occupancy Request, MO-7” out of service. See the BCI-R/BCI2-R Occupancy Arbitration table, which follows in this section for more information.
- Occupancy Status MI-20 will show the current state.
- BCI-I/BCI2-I does not support the WCS-SO or WCS-SCO₂ sensors.
- **WCS-SB/R Remote Sensor**
 - WCS-SB/R remote sensor is not supported by BCI/BCI2 as a refrigeration or freezer temperature sensor.

Table 14. BCI-R/BCI2-R occupancy arbitration table

Occupancy Request Service MO-7	Occupancy Request Present— Value MO-7	Air-Fi Wireless Occupancy Motion Sensor ^(a)	RTRM Occupancy Input J6–11,12 ^(b)	Local Occupancy Input TOV Zone Sensor	Resultant Occupancy Status MI-20
Out of Service	*(c)	Occupied	*	*	Occupied
Out of Service	*	Unoccupied	*	Not active	Unoccupied
Out of Service	*	Unoccupied	*	Active	Occupied
Out of Service	*	*	Occupied	*	Occupied
Out of Service	*	*	Unoccupied	Not active	Unoccupied
Out of Service	*	*	Unoccupied	Active	Occupied
In Service	Occupied	*	*	*	Occupied
In Service	Unoccupied	*	*	Not active	Unoccupied
In Service	Unoccupied	*	*	Active	Occupied
In Service	Occupied Bypass	*	*	*	Occupied
In Service	Occupied Standby	*	*	*	Occupied

^(a) This value cannot be viewed from the BCI-R/BCI2-R.

^(b) Occupied = open terminals, unoccupied = closed terminals.

^(c) * = Do not care.

WCS-SB/R Refrigerator Temperature Sensor Setup

Note: The following setup is not possible with BCI/BCI2. Only to UC210, UC400, UC400-B, UC600, Symbio™ 210/210e, Symbio™ 400-B/500, Symbio™ 700/800.

When using WCS-SB/R sensors with an external 10K Type II sensor probe for refrigerator/freezer monitoring, some setup will be required using Tracer TU. If there are two sensors associated to a UC, the refrigerator/freezer temperature reading will automatically average with the Space Temperature sensor if the following steps are not taken. This example assumes there is one space temperature sensor that is addressed as 1, and one refrigerator/freezer sensor that is addressed as 2. Both sensors are associated to the same unit controller.

1. Connect Tracer TU to the unit controller using any method. Navigate to the unit controller.
2. Using Tracer TU, go to the Controller Settings tab. Under the Wireless Sensor Configuration pane, uncheck the *Enable Wireless Space Sensor* box. Unchecking this box will prevent newly created references from being replaced with default references if the unit controller is power cycled.
3. Select the number of wireless sensors under the Wireless Sensors drop down. In this case it is 2.
4. Click Send to Device.
5. Go to the Analog tab.
6. Select and open analog input “**Space Temperature Local**” for editing.
7. Change the reference to Sensor 1 > Space Temperature. This will create a reference of “**wci.sensors.1.spaceTemp**”. You need to do this to remove “**Space Temperature Local**” from the

default averaging behavior.

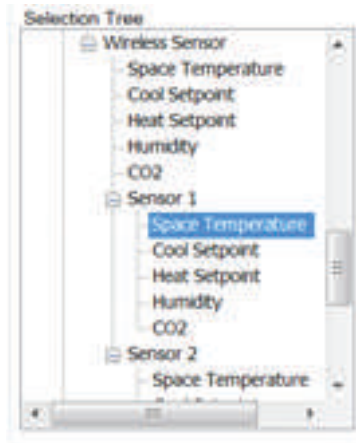

8. Hit *OK*, then *OK* again, then *Send to Device*.
9. Create a refrigeration monitoring point for sensor 2 by clicking “**Create**”.
10. Name the point, then select the reference as *Sensor 2 > Space Temperature*. This creates the point reference “**wci.sensors.2.spaceTemp**” and it will not be part of default averaging behavior.

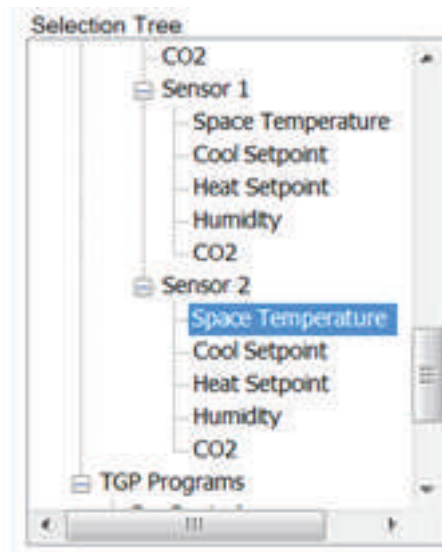

11. Check the *Add to SC Temp* box if the refrigerator temperature point is desired to be viewed at the SC level.
12. On the Alarm Conditions tab set up the conditions and actions as needed.
13. Hit *OK*, then *OK* again, then *Send to Device*.
14. Done.

WCS-SB/R Refrigerator Sensor plus Two Averaged Space Temp Sensors Setup Instructions

Note: The following setup is not possible with BCI/BCI2. Only in UC210, UC400, UC400-B, UC600, Symbio™ 210/210e, Symbio™ 400-B/500, Symbio™ 700/800.

When using a WCS-SB/R sensor with an external 10K Type II sensor probe for refrigerator/freezer monitoring, some setup will be required using Tracer TU. The WCS-SB/R sensor will be brought in as a space temperature. If there are also space sensors associated to a UC, the refrigerator/freezer temperature reading will automatically average with the space temperature sensors if the following

steps are not taken.

In this example there are three sensors; two space temperature sensors and one refrigerator sensor. The two Space Temperature sensors will be addressed as Sensor 1 and Sensor 2. The refrigerator/freezer sensor will be addressed as Sensor 3. All sensors are associated to the same unit controller, and the desire is to have the two space sensors averaging, and the refrigerator sensor not part of the averaging.

1. Connect Tracer TU to the unit controller using any connection method.
2. Using Tracer TU, go to the Controller Settings tab. Under the *Wireless Sensor Configuration* pane, uncheck the *Enable Wireless Space Sensor* box. Unchecking this box will prevent newly created references from being replaced with default averaging references if the unit controller is power cycled.
3. Select the number of wireless sensors under the *Wireless Sensors* drop down. In this example it is 3.
4. Click *Send to Device*.
5. Go to the Analog tab.
6. **Create a new analog input point called Space Temperature 1.**
7. For the reference select Sensor 1 > Space Temperature. This will create a reference of “**wci.sensors.1.spaceTemp**”. You will use this point in TGP2 to create a space temp averaging program.

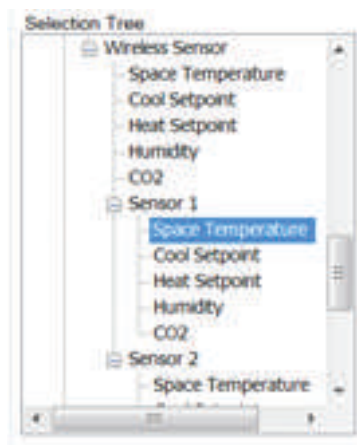

8. Hit *OK*, then *OK* again, then *Send to Device*.
9. **Create a second analog input point called Space Temperature 2.**
10. For the reference select Sensor 2 > Space Temperature. This creates the point reference “**wci.sensors.2.spaceTemp**”. You will use this point in TGP2 to create a space temp averaging program.

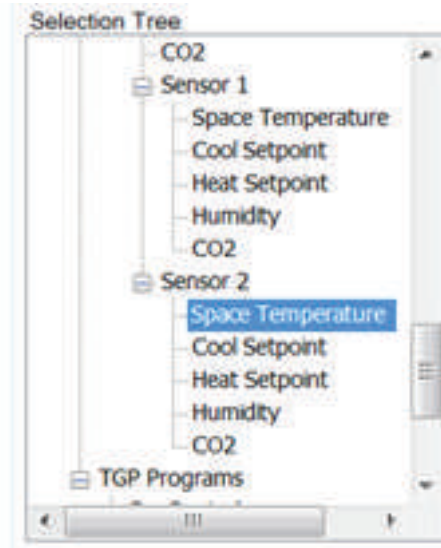

11. **Create an analog output point called *Space Temp Average***. This point will store the average temperature value for the two space sensors just created. Select Temperature under Dimensionality. No reference is needed. This point will be needed when writing the TGP2 averaging program in Step 17.
12. **Create a refrigeration monitoring analog input point** by clicking *Create*.
13. Name the point, then select the reference as Sensor 3 > Space Temperature. This creates the point reference "**wci.sensors.3.spaceTemp**". This point will not be part of the TGP2 averaging program. It will display individually.

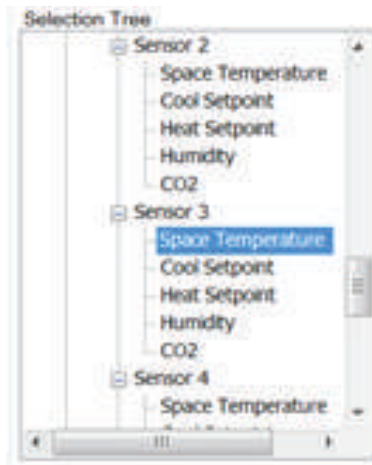

14. Check the *Add to SC Temp* box if the refrigerator temperature point is desired to be viewed at the SC level.

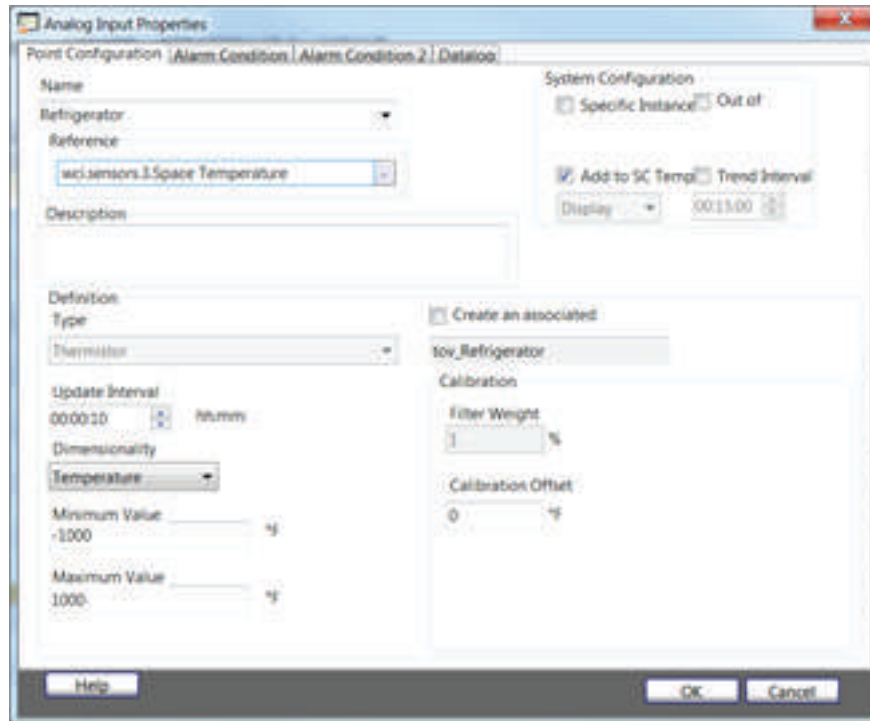

15. On the *Alarm Conditions* tab set up the conditions and actions as needed.

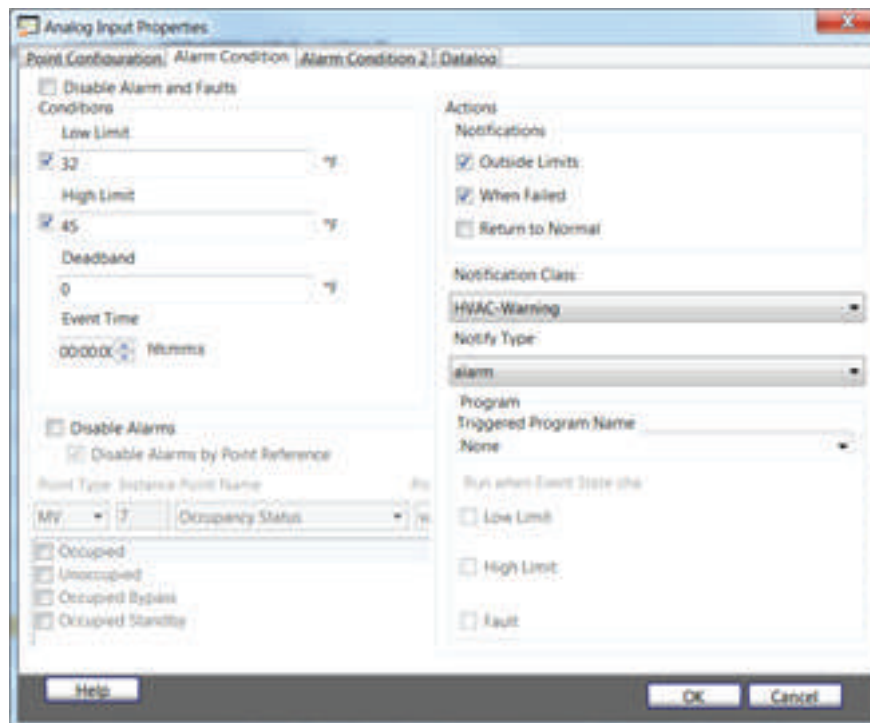

16. Hit *OK*, then *OK* again, then *Send to Device*.

17. **Create a TGP2 program to average Sensor 1 and Sensor 2**, but not Sensor 3. The result will be in Analog Output “*Space Temp Average*”, which was created in Step 11. Name the program, then *Send to Controller*.

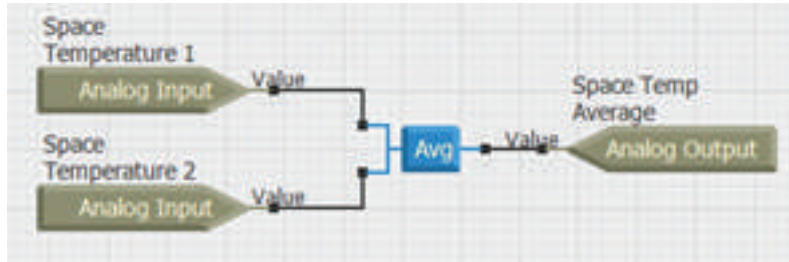

18. **Edit Space Temperature Local** to reference the new averaging analog output point in TGP2 program created in Step 17 (*Space Temp Average*). In this case it is *Analog Output Instance 4*. For the Reference Location choose Local Software, fill out Point Type, Instance Number, Display Name and Property. Send to Device.

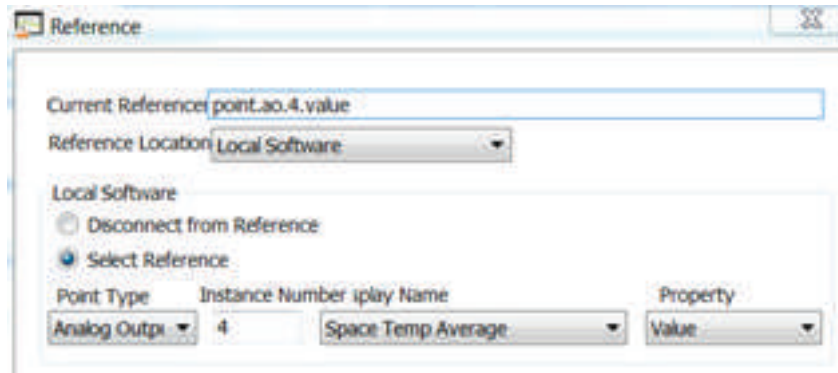
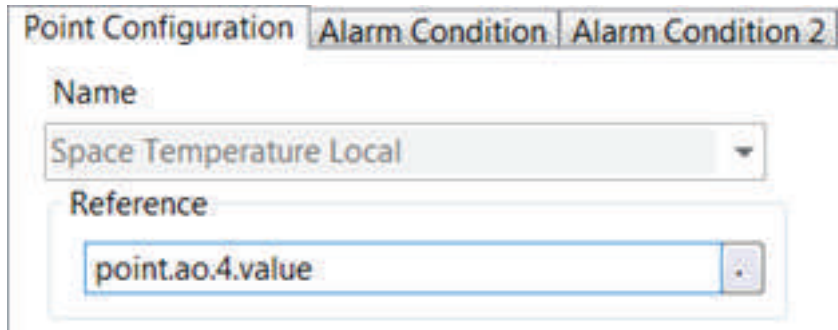



19. *Space Temperature Local* will now display the average of Sensor 1 and Sensor 2.
 20. Finished.

Setting Up Wireless Battery Monitoring

A multistate input point called *Wireless Sensor Battery Level* is automatically set up for many types of controllers. This point will auto-install into the SC so that alarming is set up. However, if you have UC600 or field installed unit controllers you will be required to manually set up this point using Tracer TU, and then install the point in SC. Below are the steps to manually set up the *Wireless Sensor Battery Level* alarming in the unit controller. Additional steps not shown here may be needed to activate the alarming in SC.

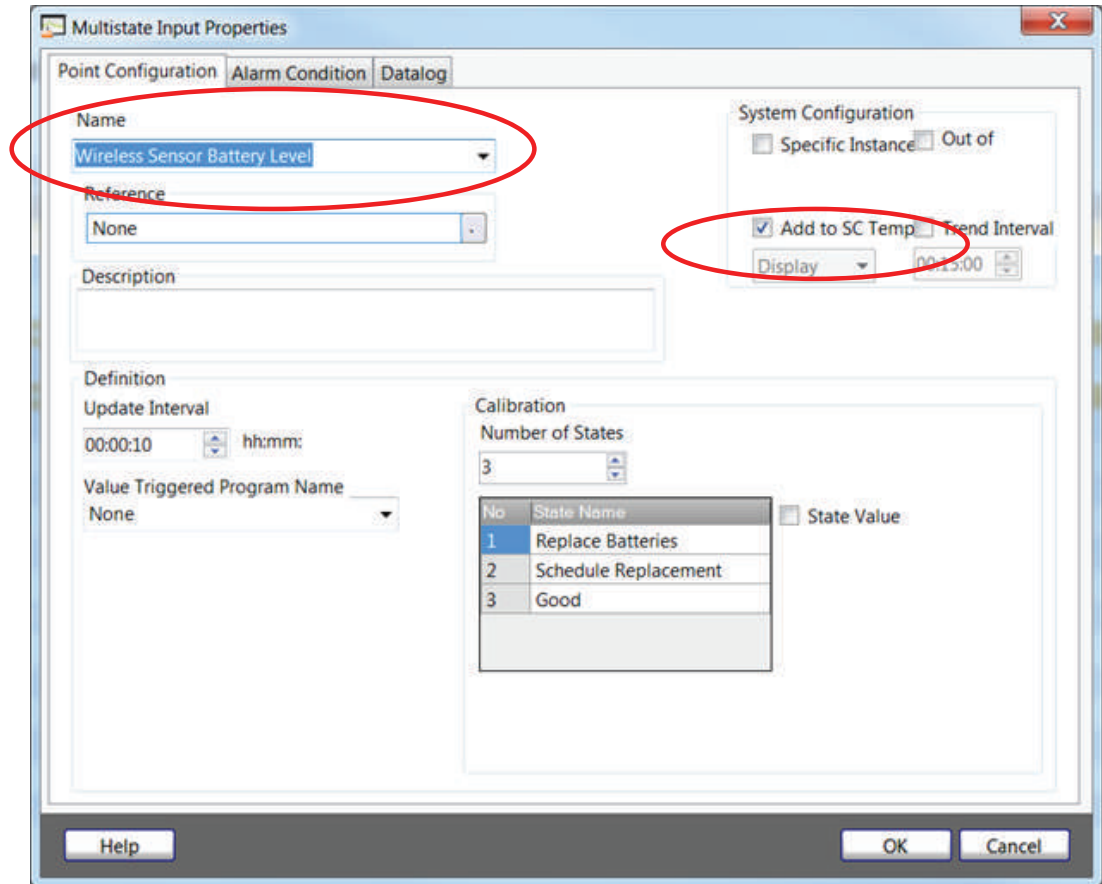
1. Go to Multistate Input tab. Click on Create.
2. Name the new point "Wireless Sensor Battery Level". (This will auto fill)
3. Insure the *Add to SC Temp* checkbox is checked.



4. Click on the Reference drop down box.
5. Change the reference from *None* to *Wireless Sensor > Battery Strength* by selecting from the tree. This will create a reference of *wci.battery*.

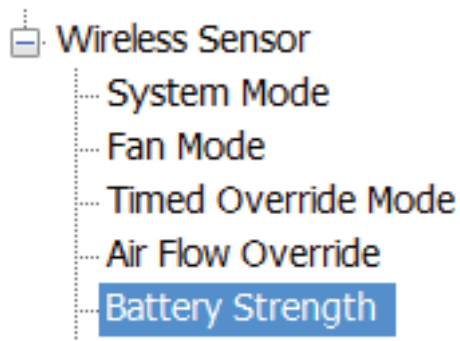

6. Click OK.
7. On the Alarm Conditions tab, make the selections as shown below.

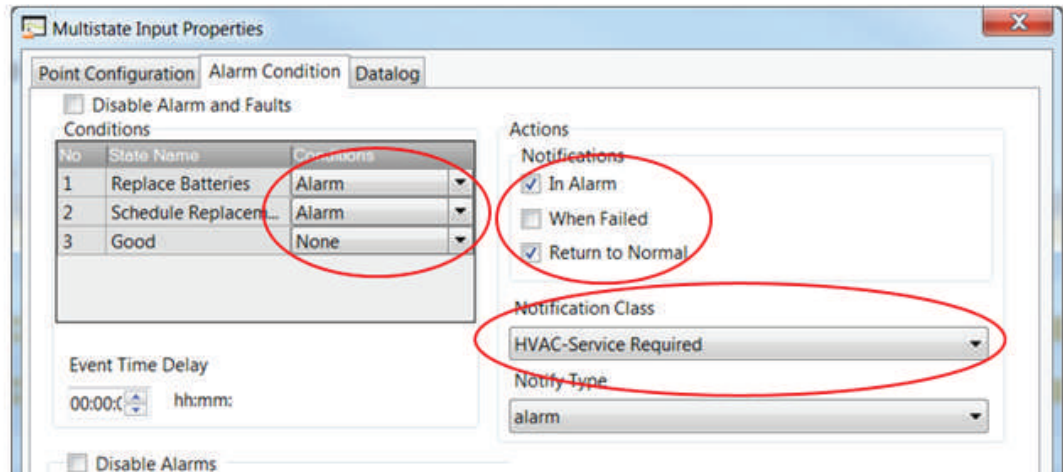

8. Hit OK, then *Send to Device* at the bottom of the MI page. The new point will be sent to SC so it is available for alarming.

How to Connect Air-Fi® Wireless Sensors Directly to SC+

Tracer SC+ supports sensors connected directly to it since version 5.1. Tracer SC+ supports up to 8 networks with six sensors maximum per network allowing a total number of 48 sensors.

Some applications include:

- Refrigerator/Freezer monitoring sensor
- Monitoring sensor for remote area
- Direct connection to devices that cannot be connected to unit controllers. For example VRF.

Notes:

- *This application only configures sensors directly connected to the SC+. Any Air-Fi sensor connected to a unit controller must be configured using the Tracer® TU service Tool.*
- *Sensor 1 for each network is default enabled.*
- *More than 1 sensor per network requires SC+ Configuration.*

How to Set-up Air-Fi Network on Tracer Synchrony

1. Address, mount and wire the Air-Fi® Wireless Communications Interface (WCI) and Air-Fi® Wireless Communications Sensors (WCSs) according to instructions on the *Air-Fi® Wireless Communication Interface (WCI) Installation Instructions (BAS-SVN038*-EN)*.
2. Open Synchrony and navigate to the Installation menu on the left hand navigator.
3. Select Air-Fi Networks and Sensors link.
4. Select the Create Network button. A new network will be displayed.
5. Edit the BACnet® Network Number, Network Name, and Network Description if needed. The BACnet® network numbers is provided by default but can be edited using the pencil icon. BACnet® network numbers should not be duplicated.
6. Click the check icon when finished.
7. Click the trash can icon to delete a network. All sensors in the network will be deleted when the network is deleted.

Note: *Networks reflected here are all the Air-Fi networks on the SC+ including the WCIs connected to unit controllers.*

Figure 64. Air-Fi networks and sensors

Air-Fi Networks and Sensors Outdoor Conditions
--- / --- RH

< Installation

Create Network Open/Close Networks

Address (NET)	Network Name	Description	BACnet Network Number	Open/Closed	Open Time Remaining	Status	Actions
▶ 1	Air-Fi Network 1	My Air-Fi Network 1	1003	Closed	---		✓ ✕
▶ 8	Air-Fi Network 8		1000	Closed	---		✎

How to Configure Air-Fi Sensors Connected Directly to Tracer SC+ without a Unit Controller

1. Select the network to add sensors and expand it (you may want to add click on the tiny arrow to the right of the network name. It may not be obvious how to expand it).
2. Select the Add sensor button.

Figure 65. Add sensor button

Air-Fi Networks and Sensors Outdoor Conditi
--- / --- RH

< Installation

Create Network Open/Close Networks

Address (NET)	Network Name	Description	BACnet Network Number	Open/Closed	Open Time Remaining	Status	Actions					
▼ 1	Air-Fi Network 1	My Air-Fi Network 1	1003	Closed	---		✓ ✕					
Add Sensor												
ID	Sensor Name	Sensor Use	Device	Heat SetPoint	Cool SetPoint	Space Temperature	Humidity	CO2	Occupancy Input	Last Reception Time	Battery	Actions
1	Sensor 1	Monitoring	---	---	---	---	---	---	---	---	---	✓ ✕
▶ 8	Air-Fi Network 8											✎

3. Select the Sensor Use.

There are two possible uses/selections:

- Monitoring
 - Device
- a. **Monitoring:** This application refers to sensors that will be used to monitor such as a freezer sensor. If Monitoring is selected, the table will auto populate with the values from the sensor.
 - b. **Device:** This application refers to sensors that are directly connected to Tracer SC+ but that will be matched with a piece of equipment. For example, for a VRF Indoor Unit. The installed device does not use a unit controller to communicate to the Air-Fi sensor.

If the Device is Use selected for sensor set use, click on the referencer icon of the Device column to choose the Family Type of an installed device.

Figure 66. Select data destination

Select Data Destination

Family Type

Equipment

Cancel **Apply**

Using the Tracer® TU Service Tool with a Wireless Network

Tracer SC+ automatically proposes points on that device to send the sensor data. Notice that the rest of the table is populated with points names from the selected device. Hover over the point name to see the values from the sensor.

To change the selection of points, click on the referencer icons.

4. Click the check mark when finished configuring that sensor.
5. Click the trash can icon to delete a sensor.
6. Click the pencil icon to edit the sensor configuration.

Note: Up to 6 sensors can be directly connected to the SC+ for each network.

Opening Air-Fi Network from Synchrony

1. Navigate to Air-Fi Networks and Sensor page.
2. Click “**Open/Close Networks**” tab.
3. Toggle the network to Open or Closed. The network will stay open for up to 90 minutes.

Figure 67. Network open close dialog



Open/Close Networks		
Air-Fi Networks		
Address (NET) ▲	Network Name	Open
8	Air-Fi Network 8	<input type="checkbox"/>

Configuring WCS Sensor

1. On the sensor, hold the Addr button for 3 seconds
2. Set to Group/Net using the up down and next buttons
3. Set the UC Address for 000, not the rotary address of the SC+
4. Select next to set the Sensor# (1-6)
5. Hold the Addr button for 3 seconds to exit addressing mode
6. From a blank display press the up arrow to force the WCS to join the network

Creating Points to the Sensor

1. In Tracer SC+, navigate to “**Points**”, then “**Create Points**” from the top of the Page.
2. Select the point type that is needed for the value, typically “**Analog Input**”.

Figure 68. Creating points in Tracer SC+

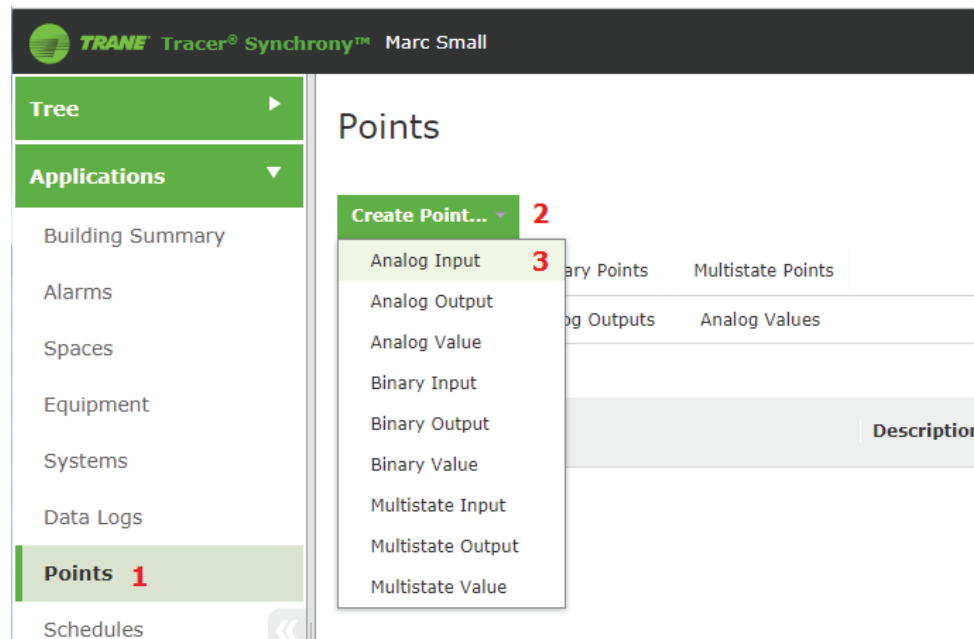

3. Define the Name, Units and select the Referencer.

Figure 69. Define name, unit, and referencer

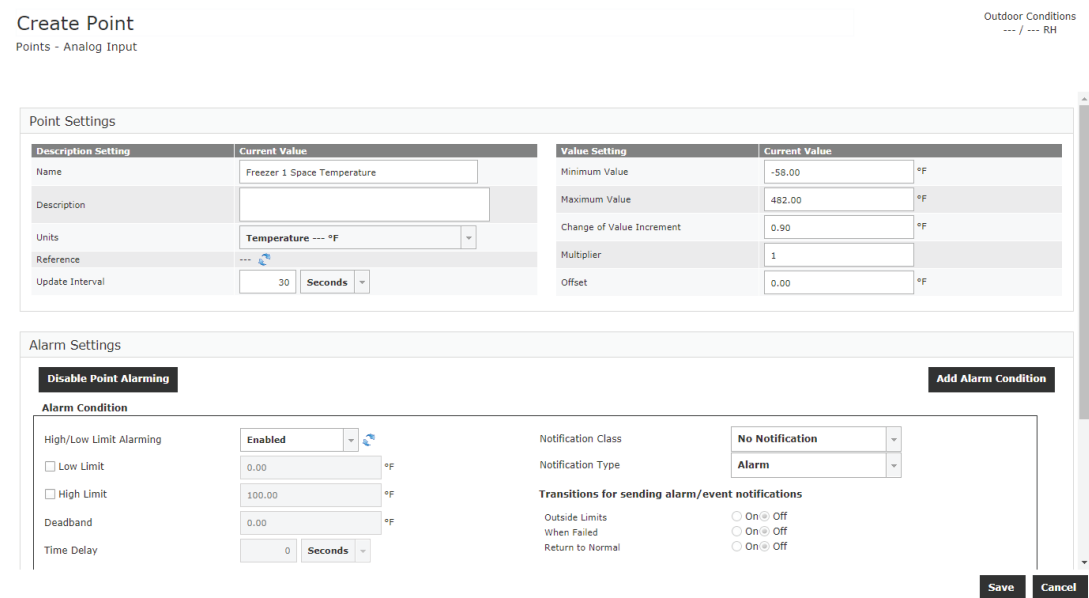

4. Select “Other Referencer”, then “air-fi” / “air-fi network” / “ sensors”, then select the desired property of the sensor.

5. Click on “Apply”.

Figure 70. Other referencer

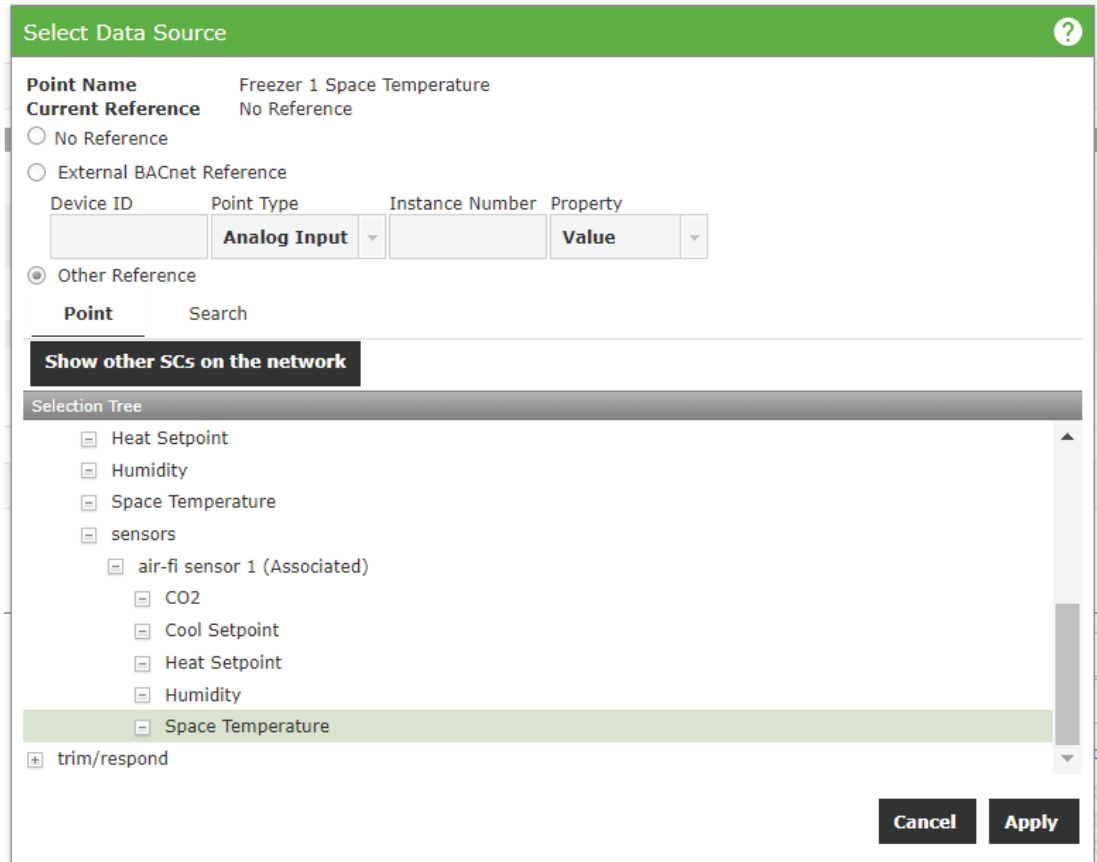

6. Make any other changes that are required such as alarm or limits settings and save the point.
7. The value of the sensor can now be used in TGP2, graphics or Data Logs

Figure 71. New point

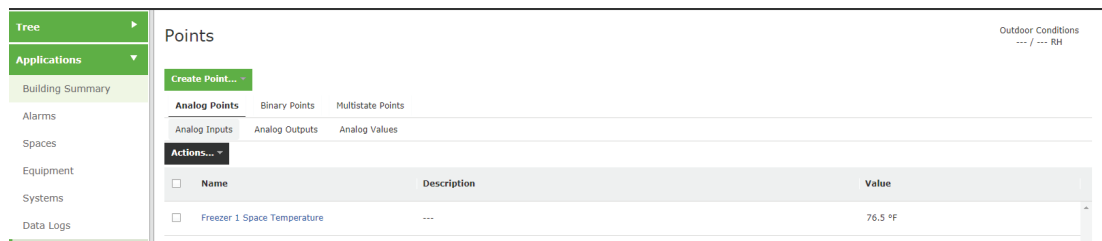

Communication History

Overview

Communication History is a tool that will help a technician pinpoint when intermittent communication and/or interference is occurring. This tool is only available when there is an SC+. Communication History can be found under the Wireless drop down menu. The tool takes logged controller communication information from the SC+ and arranges it so the technician will be able to see at-a-glance when communication is failing. The technician can look back several days or weeks to see if there is any pattern which can help in trouble shooting by showing the time the communication fails each day.

Only controllers experiencing communication failures will be shown. [Figure 72, p. 105](#) shows 9 controllers having issues.

Figure 72. Communication history tab with reported issues

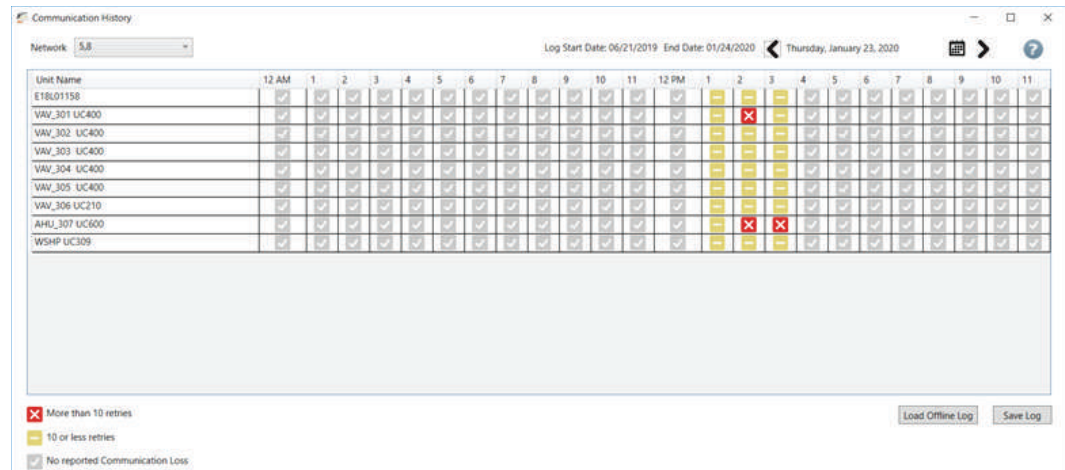

If no controllers are experiencing interference or communication loss, a message on the screen will display “No reported communication loss during selected date” as shown in Figure 73, p. 105.

Figure 73. Communication history tab without reported issues

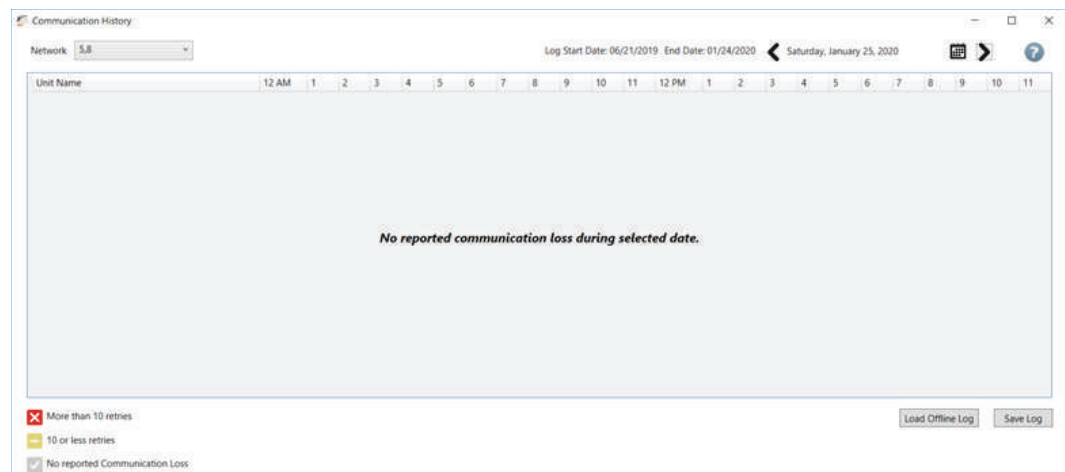

User Interface

- If you have multiple wireless networks on the SC+, this drop down menu box will allow you to change the wireless network you are viewing.

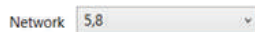

- The log start and end date are displayed. Communication logs are available within these dates for viewing.

Log Start Date: 06/21/2019 End Date: 12/26/2019

- You can navigate to a different date within the range of dates by using the back and forward arrows.



- To quickly find dates that have communication issues you can open the calendar and it will show you the dates in red that have either BACnet retries or communication loss. In this case, many days in January have communication loss logged. Clicking on the date will bring up the Communication History log for that day showing any controllers that lost communication.

Figure 74. Red highlighted dates in calendar

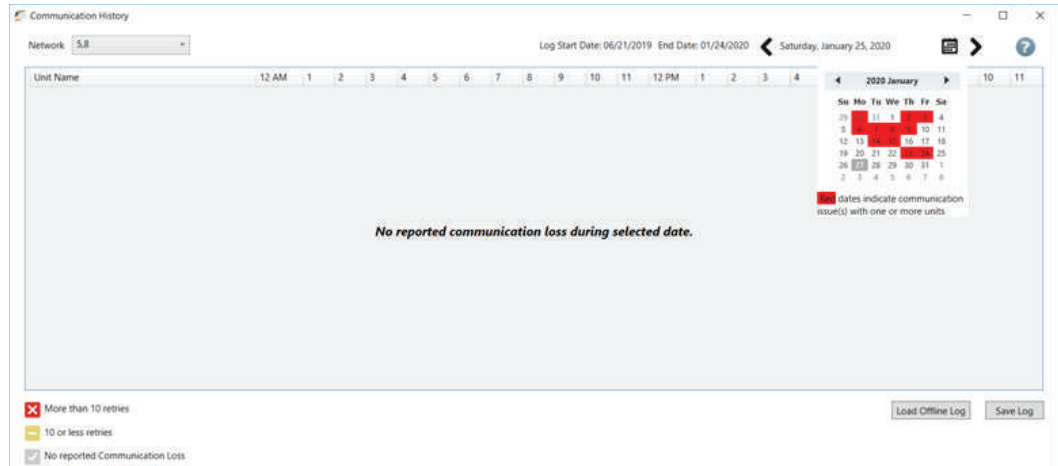

- Save Log allows the technician to save the current view to a file on the PC. The tool stores many weeks' worth of data, but eventually the older logs will be overwritten. So if it is desired to have a log saved for future viewing, the technician should save it manually using Save Log.

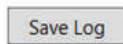

- Load Offline Log will allow the technician to view a previously saved log. This can be used while connected to a network or when working offline.

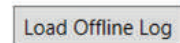

- Means controller has had more than 10 BACnet retries. More than 10 retries indicates severe communication trouble.
- Means 10 or less BACnet retries have taken place. Retries are where a Zigbee packet is attempted to be sent but is not successful. The WCI will attempt to send it a short while later. Each attempt to send is a retry. Communication is likely continuing but performance will suffer.
- Means there is no reported communication loss. It does not necessarily mean we have good communication. This tool is logging changes in BACnet retries and communication loss from the previous hour, not good communication. So if there is a gray check mark we only know there is no change in BACnet retries or communication loss from the previous hour.

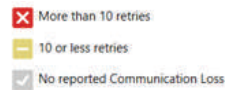

- The red X in Figure 4 shows a possible communication loss between 8am and 9am for six unit controllers. At 9am it appears communication was back to normal, but we do not actually know this for sure. This tool logs changes in communication. It is possible that at 9am, all the controllers shown are still having the exact same trouble as they did at 8am, but since there is no change, the tool shows a gray check mark "No reported communication loss."

Unit Name	12 AM	1	2	3	4	5	6	7	8	9	10	11	12 PM	1	2	3	4	5	6	7	8	9	10	11
WAV_301 UC400	✓	✓	✓	✓	✓	✓	✓	✓	✗	✓	✓	✓	✓	✓	✓	✓	✓	✓	✓	✓	✓	✓	✓	✓
WAV_302 UC400	✓	✓	✓	✓	✓	✓	✓	✓	✗	✓	✓	✓	✓	✓	✓	✓	✓	✓	✓	✓	✓	✓	✓	✓
WAV_303 UC400	✓	✓	✓	✓	✓	✓	✓	✓	✗	✓	✓	✓	✓	✓	✓	✓	✓	✓	✓	✓	✓	✓	✓	✓
WAV_304 UC400	✓	✓	✓	✓	✓	✓	✓	✓	✗	✓	✓	✓	✓	✓	✓	✓	✓	✓	✓	✓	✓	✓	✓	✓
WAV_306 UC210	✓	✓	✓	✓	✓	✓	✓	✓	✗	✓	✓	✓	✓	✓	✓	✓	✓	✓	✓	✓	✓	✓	✓	✓
WSHP_309 UC400	✓	✓	✓	✓	✓	✓	✓	✓	✗	✓	✓	✓	✓	✓	✓	✓	✓	✓	✓	✓	✓	✓	✓	✓

Channel Quality Scan Tool

When a pattern of interference or communication loss is established by using the Communication History tool, the next step should be to use the Channel Quality Scan tool to further troubleshoot. For example, if it appears that each day around 8am communication is lost, then the technician should be on site at 8am with the Channel Quality Scan tool scanning the suspected area for potential interference. If interference is found then try to determine what is causing it, or change the channel as

needed. If no interference or communication loss is indicated in Communication History, but there are still performance problems, then look for network design issues or obstructions.

Channel Quality Scan Tool

Overview

Air-Fi uses Zigbee radios and channels to pass BACnet messages from controller to controller. Channel Quality Scan is a tool which enables a technician to view available Zigbee channel bandwidth in the 2.4 GHz radio spectrum. Channel Quality Scan tool can be found under the Wireless drop down menu. Shown on this screen are the 15 Zigbee channels that Air-Fi uses. See [Figure 75, p. 107](#). These are labeled Channel 11 through 25. The green bars indicate available bandwidth for each Zigbee channel. The taller the green bar, the more bandwidth that is available and more likely the Air-Fi wireless BACnet messages will get through over the Zigbee channel. If a channel falls below the 30% threshold, it turns red and is not recommended to be used because it does not have enough bandwidth to support transmitting BACnet messages over that Zigbee channel. See [Figure 76, p. 107](#) which shows channels 17 and 18 below the 30% threshold.

Figure 75. Typical Channel Quality Scan screen where all channels will support Air-Fi communication



Figure 76. Channel Quality Scan screen showing channels 17 and 18 with heavy traffic that will not support Air-Fi communication



Points to remember:

- The bars do not indicate signal strength.
- The taller green bars indicate quieter channels which have more available bandwidth and are more likely to get BACnet messages through.
- Channels above 30% will have enough available bandwidth to support sending and receiving BACnet messages over the Zigbee channel.
- Buildings typically use Wi-Fi channels 1, 6 and 11 for their wireless networks. See [Figure 77, p. 108](#) below which shows how Wi-Fi and Zigbee channels relate to each other in the 2.4 GHz spectrum.
 - Wi-Fi channel 1 broadcasts in the space where Zigbee channels 11 through 14 are located.
 - Wi-Fi channel 6 broadcasts in the space where Zigbee channels 16 through 19 are located.
 - Wi-Fi channel 11 broadcasts in the space where Zigbee channels 21 through 24 are located.
- Wi-Fi channels are about 20 MHz wide, but they seldom use all of that bandwidth. See [Figure 77, p. 108](#). Zigbee channels that are situated near the edges of the Wi-Fi channels are able to communicate without problem because Wi-Fi is not always using the entire channel. For instance, Zigbee channel 11 and 14 are at the edge of Wi-Fi channel 1, but are able to communicate without trouble as long as Wi-Fi channel 1 is not using the entire channel.
- Other Zigbee channels like 12 and 13 are near the center of Wi-Fi channel 1, but if Wi-Fi channel 1 is not being used, or does not have a lot of traffic, Zigbee channels 12 and 13 will work fine.
- Wi-Fi and Zigbee channels are designed to coexist with each other under typical conditions. However, sometimes Wi-Fi channels have extraordinary traffic on them and can use up much of the available bandwidth.
- Note channels 15, 20 and 25 are not affected by Wi-Fi channels 1, 6 and 11. Channel 26 is not used by Air-Fi.
- In the [Figure 76, p. 107](#) above, Wi-Fi channel 6 (which uses the space where Zigbee channels 16 through 19 are located) has heavy traffic and is taking up most of the bandwidth to a point where Zigbee channels 17 and 18 are red and don't have enough bandwidth to support good Air-Fi communication.

Figure 77. The relationship between Wi-Fi and Zigbee channels in the 2.4 GHz spectrum

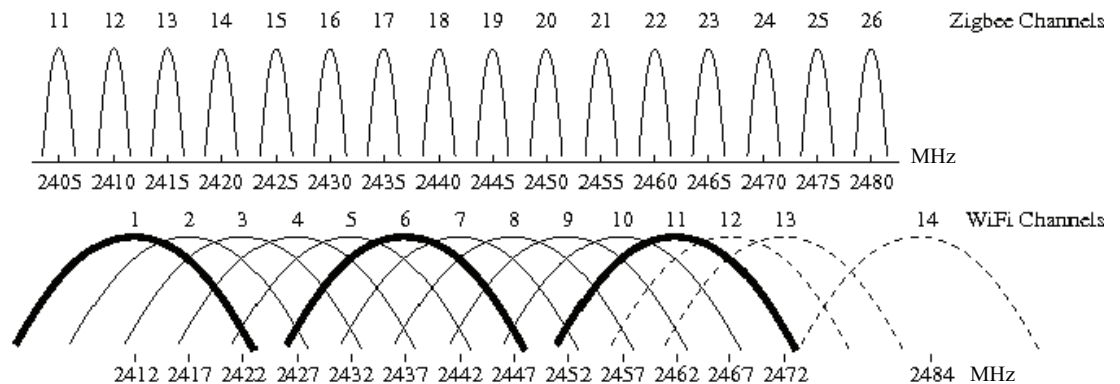

Changing a Zigbee channel

Before changing a channel, make sure the Air-Fi network is properly designed with centrally located coordinator and all devices within range and awareness of any obstacles that may affect the signal. Most often, a poor performing network can be traced back to a network that violates some of the network design rules. If a channel change is necessary, there are two ways to accomplish this. The first way is physically changing the NET address on each WCI and sensor in the network. The second way is by using Tracer TU to send a channel change request.

- Physically changing the NET rotary address on each WCI and sensor in the network should be started by disbanding the network. After the network is disbanded the NET addresses of the WCI and sensors can be changed. You may want to consult with Technical Support before using this method.

Using the Tracer® TU Service Tool with a Wireless Network

- The best way to change a Zigbee channel is using Tracer TU. Any of the 15 Zigbee channels can be selected under (Wireless tab > Advanced). See Tracer TU Help topic “Changing the Channel of a Wireless Network” for more information on how to accomplish this.

Note: This method does not require touching any WCI, but will require touching each sensor in the network after the channel is changed.

Also, it is strongly recommended you use a Direct Connection via USB cable to the SC/SC+ to make this channel change. This is explained in “Changing the Channel of a Wireless Network.”

- The WCI NET rotary address 1 to 8 correspond to default Zigbee channels. Table 15, p. 109 below shows the default channels used. Knowing which Zigbee channels are used by the corresponding WCI NET rotary setting is helpful when selecting a channel that has available bandwidth as indicated on the Channel Quality Scan tool.

Table 15. WCI NET rotary address and corresponding default zigbee channel

WCI NET rotary setting	Zigbee Channel
1	15
2	20
3	14
4	19
5	16
6	21
7	11
8	25

Multiple Uses

This tool was primarily designed to be used for troubleshooting possible interference issues that can cause Air-Fi performance to suffer. The Channel Quality Scan tool can be used along with the Communication History tool, when interference is suspected. The Communication History tool will show date and time when there is possible interference so the technician will know the best time to use the Channel Quality Scan Tool to scan the area and look for channels that may have high traffic causing interference and lost communication.

Note: Communication History Tool is only available for SC+, not SC.

The Channel Quality Scan tool can also be used as a site survey tool where a technician can go into a building and find the best channel to use before creating the Air-fi network. And finally, it can be used as a commissioning tool where after the installation is finished the scan data can be saved for future reference.

Scanning and Exporting (saving) scan data

Scanning automatically starts when the Channel Quality Scan tool is opened. As the tool runs, it is caching the data in the background to your hard drive. The Recording Data button will be red and the timer will be counting up as an indication that it is storing the data. If it is desired to save this data, pressing the Export button will save the data in the form of a .csv file to the hard drive. See Figure 78, p. 109. The data will be saved to this path; Documents > Tracer TU > ChannelQualityScan. The saved .csv file can be sent to Technical Support for evaluation.

Figure 78. Recording information and buttons



- Pressing the Export button will save all cached data from the time the scan started until the Export button is pressed.
- Pressing Stop will halt the scanning and allow you to Export the .csv file.

Using the Tracer® TU Service Tool with a Wireless Network

- Pressing Start after the Stop button is pressed will initiate a new set of scan data. The previous data will be lost.
- The scan data cache will be flushed when the tool is closed, so export it before closing if the data is to be saved.

Hover Information

On the Channel Quality Scan screen, if you hover over one of the bars a pop up will show additional information about the channel. See [Figure 79, p. 110](#) and [Figure 80, p. 110](#).

- Shows the Zigbee Channel.
- Shows the center frequency of the channel in MHz (Note: 2425 MHz = 2.425 GHz)
- Shows % Available Bandwidth.
- May also show the Default Channel, NET#. The NET# corresponds to the NET rotary setting 1 through 8 on the WCI. [Figure 79, p. 110](#) shows NET 1, which corresponds to NET Rotary address 1 on the WCI. This is the same information found in [Table 15, p. 109](#) above. Only eight of the channels will show a NET#. The other seven channels do not have a corresponding NET rotary number. But you can reference to see where these channels line up in the spectrum using [Figure 77, p. 108](#).

Figure 79. Hover pop-up information

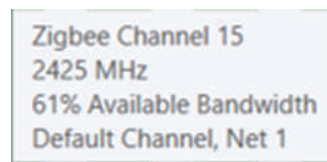

Figure 80. Hovering over channel 15 with cursor



Trane - by Trane Technologies (NYSE: TT), a global innovator - creates comfortable, energy efficient indoor environments for commercial and residential applications. For more information, please visit trane.com or tranetechnologies.com.

Trane has a policy of continuous product and product data improvements and reserves the right to change design and specifications without notice. We are committed to using environmentally conscious print practices.

BAS-SVX40N-EN 15 Sep 2024
Supersedes BAS-SVX40M-EN (May 2023)

©2024 Trane