



Installation, Operation, and Maintenance

Symbio™ 500 Programmable Controller



⚠ SAFETY WARNING

Only qualified personnel should install and service the equipment. The installation, starting up, and servicing of heating, ventilating, and air-conditioning equipment can be hazardous and requires specific knowledge and training. Improperly installed, adjusted or altered equipment by an unqualified person could result in death or serious injury. When working on the equipment, observe all precautions in the literature and on the tags, stickers, and labels that are attached to the equipment.



Introduction

The Symbio Symbio 500 programmable controller is a multi-purpose, programmable controller. Programming is done through the Tracer Graphical Programming (TGP2) Editor. This field-installed device is designed to control the following types of equipment:

- Single- and dual-duct variable-air-volume (VAV) units
- Fan coils
- Unit ventilators
- Blower coils
- Water-source heat pumps (WSHP)
- Small air handlers

This guide provides information on installing, operating, and maintaining the controller.

Warnings, Cautions, and Notices

Safety advisories appear throughout this manual as required. Your personal safety and the proper operation of this machine depend upon the strict observance of these precautions.

The three types of advisories are defined as follows:



Indicates a potentially hazardous situation which, if not avoided, could result in death or serious injury.



Indicates a potentially hazardous situation which, if not avoided, could result in minor or moderate injury. It could also be used to alert against unsafe practices.



Indicates a situation that could result in equipment or property-damage only accidents.

Important Environmental Concerns

Scientific research has shown that certain man-made chemicals can affect the earth's naturally occurring stratospheric ozone layer when released to the atmosphere. In particular, several of the identified chemicals that may affect the ozone layer are refrigerants that contain Chlorine, Fluorine and Carbon (CFCs) and those containing Hydrogen, Chlorine, Fluorine and Carbon (HCFCs). Not all refrigerants containing these compounds have the same potential impact to the environment. Trane advocates the responsible handling of all refrigerants.

Important Responsible Refrigerant Practices

Trane believes that responsible refrigerant practices are important to the environment, our customers, and the air conditioning industry. All technicians who handle refrigerants must be certified according to local rules. For the USA, the Federal Clean Air Act (Section 608) sets forth the requirements for handling, reclaiming, recovering and recycling of certain refrigerants and the equipment that is used in these service procedures. In addition, some states or municipalities may have additional requirements that must also be adhered to for responsible management of refrigerants. Know the applicable laws and follow them.

⚠ WARNING

Proper Field Wiring and Grounding Required!

Failure to follow code could result in death or serious injury.

All field wiring MUST be performed by qualified personnel. Improperly installed and grounded field wiring poses FIRE and ELECTROCUTION hazards. To avoid these hazards, you MUST follow requirements for field wiring installation and grounding as described in NEC and your local/state/national electrical codes.

⚠ WARNING**Personal Protective Equipment (PPE) Required!**

Failure to wear proper PPE for the job being undertaken could result in death or serious injury.

Technicians, in order to protect themselves from potential electrical, mechanical, and chemical hazards, **MUST** follow precautions in this manual and on the tags, stickers, and labels, as well as the instructions below:

- Before installing/servicing this unit, technicians **MUST** put on all PPE required for the work being undertaken (Examples; cut resistant gloves/sleeves, butyl gloves, safety glasses, hard hat/bump cap, fall protection, electrical PPE and arc flash clothing). **ALWAYS** refer to appropriate Safety Data Sheets (SDS) and OSHA guidelines for proper PPE.
- When working with or around hazardous chemicals, **ALWAYS** refer to the appropriate SDS and OSHA/GHS (Global Harmonized System of Classification and Labelling of Chemicals) guidelines for information on allowable personal exposure levels, proper respiratory protection and handling instructions.
- If there is a risk of energized electrical contact, arc, or flash, technicians **MUST** put on all PPE in accordance with OSHA, NFPA 70E, or other country-specific requirements for arc flash protection, **PRIOR** to servicing the unit. **NEVER PERFORM ANY SWITCHING, DISCONNECTING, OR VOLTAGE TESTING WITHOUT PROPER ELECTRICAL PPE AND ARC FLASH CLOTHING. ENSURE ELECTRICAL METERS AND EQUIPMENT ARE PROPERLY RATED FOR INTENDED VOLTAGE.**

⚠ WARNING**Follow EHS Policies!**

Failure to follow instructions below could result in death or serious injury.

- All Trane personnel must follow the company's Environmental, Health and Safety (EHS) policies when performing work such as hot work, electrical, fall protection, lockout/tagout, refrigerant handling, etc. Where local regulations are more stringent than these policies, those regulations supersede these policies.
- Non-Trane personnel should always follow local regulations.

⚠ WARNING**Cancer and Reproductive Harm!**

This product can expose you to chemicals including lead and bisphenol A (BPA), which are known to the State of California to cause cancer and birth defects or other reproductive harm. For more information go to www.P65Warnings.ca.gov.

Copyright

This document and the information in it are the property of Trane, and may not be used or reproduced in whole or in part without written permission. Trane reserves the right to revise this publication at any time, and to make changes to its content without obligation to notify any person of such revision or change.

Trademarks

All trademarks referenced in this document are the trademarks of their respective owners.

Revision History

- Following updates are made to the the General Information chapter:
 - Added Ordering Numbers and Smoke Control Support (UUKL) sections.
 - Updated Specifications section.



Table of Contents

General Information	6
Ordering Numbers	6
Specifications	6
Sensors	7
Device Connections	7
Smoke Control Support (UUKL)	8
Expansion Modules	8
Accessories	8
Required Tools	8
Symbio User Interface (UI)	8
Connecting to Symbio UI	8
Scheduling	9
Trane Wi-Fi Module	9
Trane Connect	9
Mounting the Symbio 500	10
Clearances	10
DIN Rail	10
Wiring	12
Overview	12
General Instructions	13
BACnet® MS/TP Communication Link	13
BACnet/IP Over Wired Ethernet Communications	13
Air-Fi Wireless BACnet® Communications	13
Wiring Guidelines for Wired BACnet MS/TP	13
Wiring Best Practices	14
Setting Up the Controller on a BACnet Link	14
Setting the Address	15
BACnet Networks Without a Tracer SC+ System Controller	15
BACnet Networks With a Tracer SC+ System Controller	16
Ethernet	16
Power Supply	17
Transformer Recommendations	17
Wiring Recommendations	17
Connecting Wires	18
Power On Check	18
Inputs/Outputs	19
Pre-Power Checks	19
Wiring Requirements	21
Providing Low-voltage Power for I/Os	21
Terminal Locations	22

Pressure Transducer Inputs	23
Binary Inputs	23
0–10 Vdc Analog Inputs	24
0–20 mA Analog Inputs	25
Variable Resistance Analog Inputs.....	26
Analog Outputs	27
Relay (Dry Contact/Binary Outputs).....	28
TRIAC Wiring.....	29
Operation	31
LED Locations.....	31
LED Descriptions, Activities, and Troubleshooting	31
Marquee LED Status and Error Codes	33
Configuration and Maintenance.....	36
Task 1; Load Application Code on a Blank Symbio 500	36
Task 2; Choose a Symbio 500 Configuration Option	36
Task 3; Specify Controller Settings	36
Task 4; Setup and Discover XM30, XM32, XM70, XM90 Expansion Modules	36
Task 5; Specifying an Equipment Configuration	36
Task 6; Commissioning the Hard-wired Points	37
Task 7; Modify and Create TGP2 Programs (As Needed).....	37
Task 8; Monitoring/Viewing Point, Alarm, and Controller Status	37
Task 9; Backing Up/Restoring Files and Configurations	37
Maintenance	38
Commissioning and Troubleshooting in Powered State	39
Voltage Inputs	39
Resistive Inputs	39
Current Inputs, Methods 1 or 2.....	40
24 Vac Measurement	41
Binary Inputs, 24 Vac Detect, Method 1 or 2	42
Binary Inputs, Based on Analog Output Connection.....	42
Open-collector Based Binary Sensors	43
Voltage Analog Output.....	43
Current Analog Output, Methods 1 or 2	44
Binary Output, TRIAC High Side Switching, Methods 1 or 2.....	44
Binary Output, TRIAC Low Side Switching, Methods 1 or 2	45
Ground Measurements	46
Resources.....	47



General Information

Ordering Numbers

Table 1. Ordering numbers

Ordering Number	Description
BMSY500AAA0100011	Symbio™ 500, Programmable Controller.
BMSY500UAA0100011	Symbio 500, Programmable Controller, UL-864/UUKL ^(a) .
BMSY500ABA0100011	Symbio 500 with RTU or HP program.

^(a) When installed and programmed in accordance with the *Engineered Smoke Control System for the Tracer® SC+ System Controller Application Guide* (BAS-APG040*-EN).

Specifications

Storage	
Temperature	-67°F to 203°F (-55°C to 95°C)
Relative humidity	Between 5% to 95% (non condensing)
Operating	
Temperature	-40°F to 158°F (-40°C to 70°C)
Humidity	Between 5% to 95% (nonconducting)
Power	20.4 to 27.6 Vac (24 Vac, ±15% nominal) 50 to 60 Hz 24 VA
Mounting weight of controller	Mounting surface must support 0.80 lb. (0.364 kg)
Environmental rating (enclosure)	NEMA 1
Plenum rating	Not plenum rated. The Symbio 500 must be mounted within a rated enclosure when installed in a plenum.
Wiring/Transformer	
16 AWG (recommended) copper wire	
<ul style="list-style-type: none"> UL Listed, Class 2 power transformer 20.4 to 27.6 Vac (24 Vac, ±15% nominal) The transformer must be sized to provide adequate power to the controller and outputs. For more information on transformer sizing, see <i>Symbio™ 500 Programmable Controller - Installation, Operation, and Maintenance</i> (BAS-SVX090*-EN). 	
Agency Compliance	
<ul style="list-style-type: none"> UL60730-1 PAZX (Open Energy Management Equipment) UL94-5V Flammability CE Marked. The European Union (EU) Declaration of Conformity is available from your local Trane® office. Only Applicable for specific part numbers listed in previous section: UL864/UUKL Smoke Control (when installed and programmed in accordance with the <i>Engineered Smoke Control System for the Tracer® SC+ System Controller Application Guide</i> (BAS-APG040*-EN)). UKCA Marked FCC Part 15, Subpart B, Class B Limit VCCI-CISPR 32:2016: Class B Limit AS/NZS CISPR 32:2015: Class B Limit CAN ICES-003(B)/NMB-003(B) The Symbio 500 is BTL certified as a B-BC profile device. A complete list of Trane certified devices is available at www.bacnetinternational.org. <p>Note: The Symbio 500 programmable controller supports being a BBMB. This is a specific functionality and is different than the profile certification. The Symbio 500 cannot be a router.</p>	

Sensors

⚠ WARNING

Electrical Shock Hazard!

Failure to follow instructions below could result in death or serious injury.

Do not mix Class 1 and Class 2 voltage wiring in an enclosure or on a controller without an approved barrier between wiring.

The Symbio 500 controller supports the following sensor types:

- Zone temperature sensors (resistive and thermistor)
- Linear 0–20 mA, such as humidity sensors
- Linear 0–10 Vdc, such as indoor air-quality sensors
- 3-wire pressure transducer inputs
- RTD sensors

Device Connections

Symbio 500 controller supports the following device connections:

Table 2. Device connections

Connection	Quantity	Types	Range	Notes
Analog Input (AI1 to AI5)	5	Thermistor	10kΩ – Type II, 10kΩ – Type III, 2252Ω – Type II, 20kΩ – Type IV, 100 kΩ	These inputs can be configured for timed override capability. Supports *, ** for Trane Zone Sensors.
		RTD	Balco™ (Ni-Fe) 1kΩ, 385 (Pt) 1kΩ, 375 (Pt) 1kΩ, 672 (Ni) 1kΩ,	
		Setpoint (Thumbwheel)	189Ω to 889Ω	
		Resistive	100Ω to 100kΩ	Typically used for fan speed switch.
Universal input (UI1 and UI2)	2	Linear Current	0–20mA	These inputs may be configured to be thermistor or resistive inputs, 0– 10 Vdc inputs, or 0–20 mA inputs.
		Linear Voltage	0–10Vdc	
		Thermistor	10kΩ – Type II, 10kΩ – Type III, 2252Ω – Type II, 20kΩ – Type IV, 100 kΩ	
		RTD	Balco™ (Ni-Fe) 1kΩ, 385 (Pt) 1kΩ, 375 (Pt) 1kΩ, 672 (Ni) 1kΩ,	
		Setpoint (Thumbwheel)	189Ω to 889Ω	
		Resistive	100Ω to 100kΩ	
		Binary	Dry contact	Low impedance relay contact.
Pulse Accumulator	Solid state open collector	Minimum dwell time is 25 milliseconds ON and 25 milliseconds OFF.		
Binary input (BI1 to BI3)	3		24 Vac detect	The controller provides the 24Vac that is required to drive the binary inputs when using the recommended connections.
Binary Outputs (BO1 to BO3)	3	Form C Relay	0.5A @ 24Vac pilot duty	Ranges given are per contact. Power needs to be wired to the binary output. All outputs are isolated from each other and from ground or power. Note: Class 1 voltages shall not be used on Symbio 400–B/500 controllers.



General Information

Table 2. Device connections (continued)

Connection	Quantity	Types	Range	Notes
Binary Outputs (BO4 to BO9)	6	Triac	0.5A @ 24Vac resistive and pilot duty	Ranges given are per contact and power comes from the TRIAC SUPPLY circuit. Use for modulating TRIACs. User determines whether closing high side (providing voltage to the grounded load) or low side (providing ground to the power load).
Analog Output / Binary Input (AO1/ B14 and AO2/ B15)	2	Linear Current	0 to 20mA	Each termination must be configured as either an analog output or binary input.
		Linear Voltage	0 to 10Vdc	
		Binary Input	Dry contact	
		Pulse Width Modulation	80 Hz signal @ 15Vdc	
Pressure Inputs (P11 and P12)	2		0 to 5 In H2O	Pressure inputs supplied with 5 volts (designed for Kavlico™ pressure transducers).
Point total	23			

Smoke Control Support (UUKL)

The Symbio™ 500 Controller is available in a UL864 certified version, approved to operate as a component of a UUKL system with the Tracer SC+ System Controller (refer to the ordering numbers section). For more information, see *Engineered Smoke Control System for the Tracer SC+ System Controller* (BAS-APG040*-EN).

Expansion Modules

The Symbio 500 controller has 23 on-board points. The controller can be point-expanded by using expansion modules. The Symbio 500 can have an additional 110 points, for a total of 133 points

Any combination of XM30, XM32, XM70, or XM90 Expansion Modules are supported. A maximum of two XM30, or XM32 modules (in aggregate) can be powered from the DC power of the IMC link. XM70 and XM90 modules require an AC power supply.

For more information, see the *Tracer XM30, XM32, XM70, and XM90 Expansion Modules Installation, Operations, and Maintenance* (BAS-SVX46*-EN).

Accessories

See the *Symbio™ 500 Programmable Controller Data Sheet Product Data* (BAS-PRD057*-EN) for details on accessories.

Required Tools

The following tools are required to install and initially test the Symbio 500 controller:

- Drill and appropriate bits for DIN rail mounting
- A #2 Phillips-head screwdriver
- A 1/8 inch (3.2 mm) wide, flat-bladed screwdriver
- Digital multimeter

Symbio User Interface (UI)

The Symbio 500 controller offers a web-based user interface (UI) used for installation, integration, and service tasks.

Connecting to Symbio UI

1. Connect a laptop to the USB service tool port using a USB 2.0 A to B cable. Symbio UI can only be accessed over USB connection.
2. Open a web browser and connect to <http://198.80.18.1> to access Symbio UI.

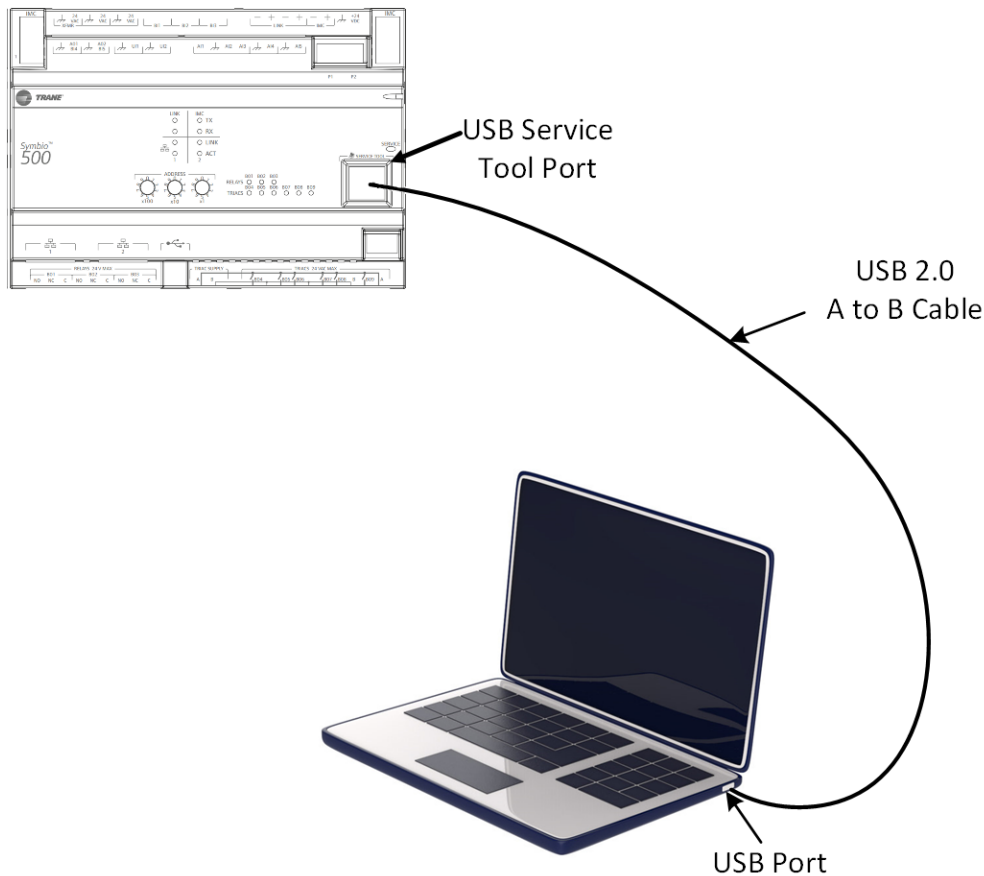
Figure 1. Connecting to Symbio UI

Scheduling

The Symbio 500 controller contains a scheduling application that is accessed through the Web UI. This scheduling capability is primarily for temporary jobsite construction when the SC+ controller is not yet available.

Trane Wi-Fi Module

The Symbio 500 controller can support the Trane Wi-Fi module on the USB port:

- X13651743001 Wi-Fi Field Installed Kit, 1 m cable, 70C
- X13651743002 Wi-Fi Field Installed Kit, 2.9 m cable, 70C

Trane Connect

The Symbio 500 module is Trane Connect enabled by either a Wi-Fi connection or via an Ethernet connection with the SC+ controller. The web UI is used to setup the module and connection.



Mounting the Symbio 500

Clearances

Figure 2. Controller dimensions

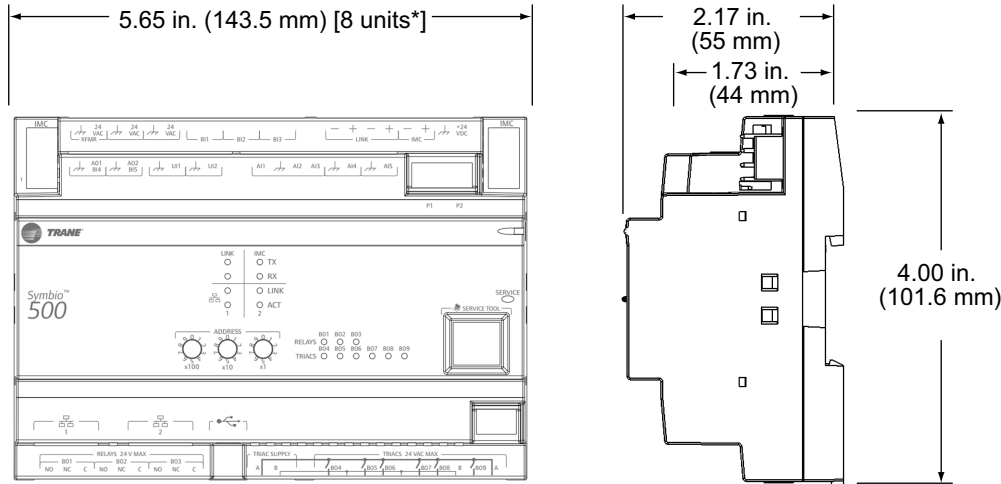

Note: DIN Standard 43 880, Built-in Equipment for Electrical Installations, Overall Dimensions and Related Mounting Dimensions.

Figure 3. DIN Rail

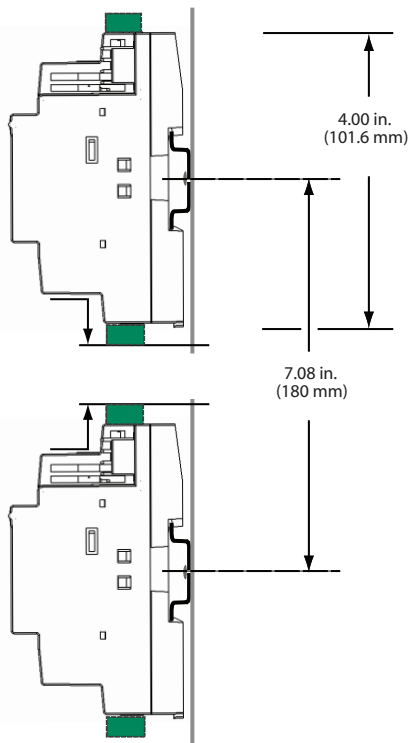

DIN Rail

Note: Always install devices on a horizontally oriented DIN rail to allow proper ventilation.

To mount controller:

1. Hook the controller over the top of the DIN rail.

2. Gently push on lower half of device in the direction of the arrow until the release clip locks into place.

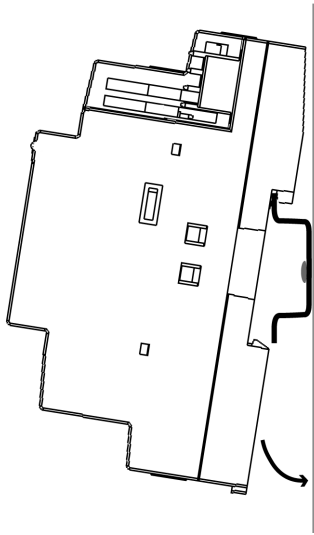

To remove or reposition the controller:

1. Disconnect all connectors.
2. Insert a screwdriver blade into the slotted release clip (shown below) and gently pry upward to disengage the clip.
3. While holding tension on the clip, lift the controller upward to free it from the DIN rail.
4. Reposition the controller by sliding it sideways or by removing it completely and reattaching it.
5. Gently push on lower half of device in the direction of the arrow until the release clip locks into place.

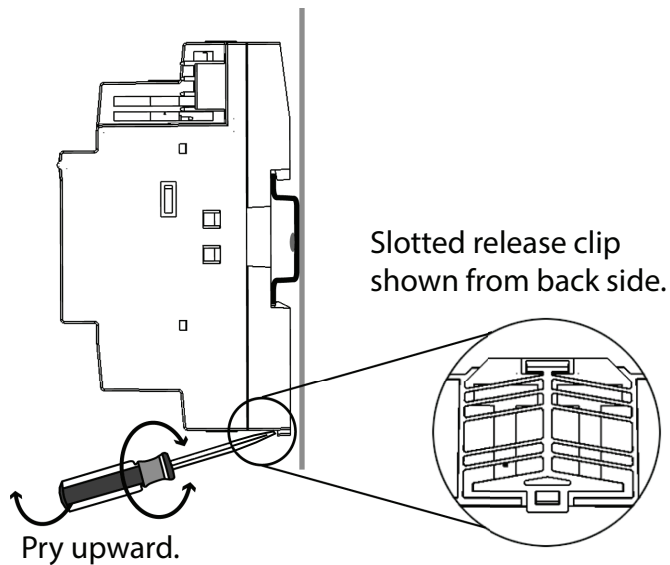

Wiring

Overview

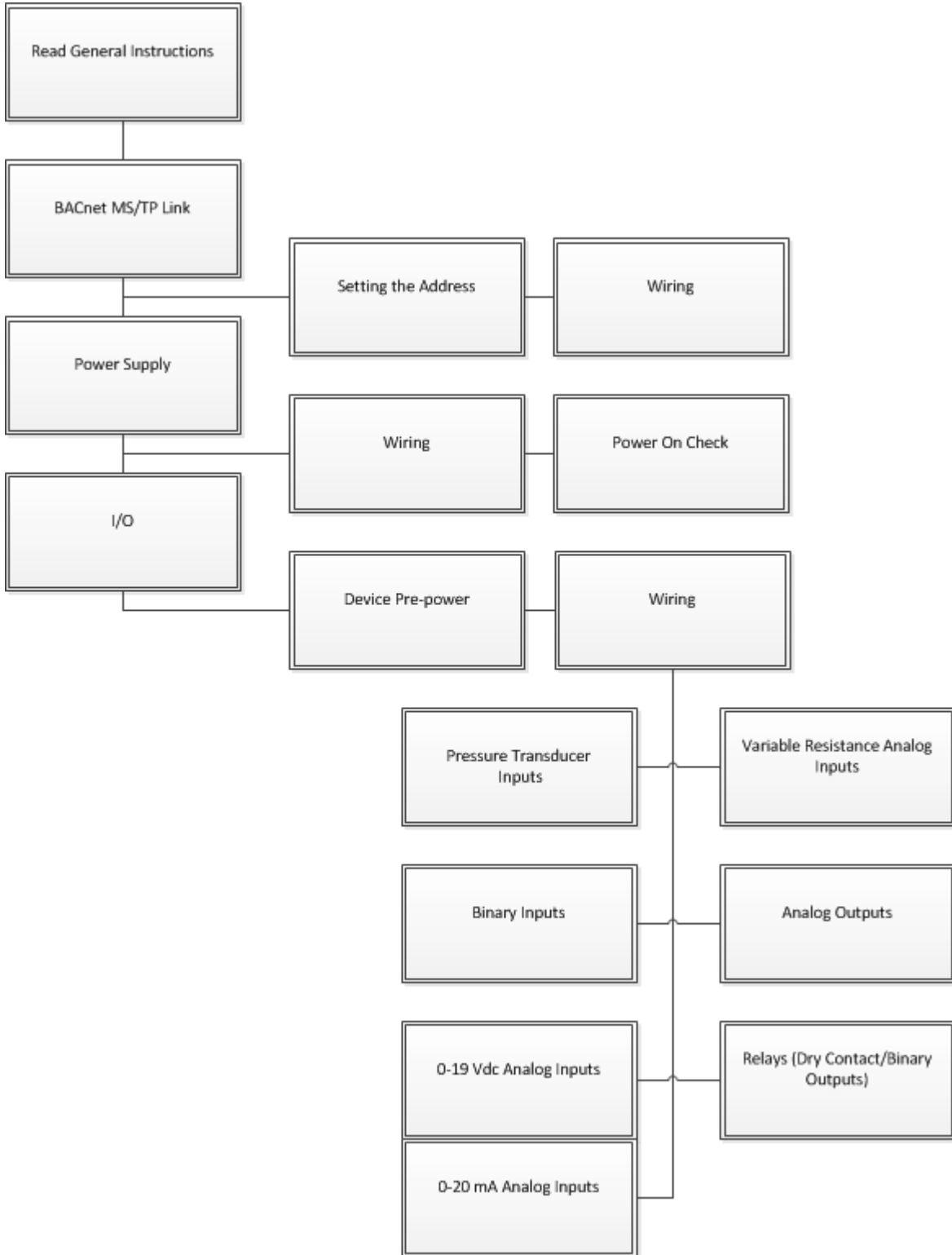

General Instructions

All wiring must comply with the National Electrical Code (NEC™) and local electrical codes.

To connect wires to terminals when connecting wires to the Symbio 500 or XM30:

1. Strip wires to expose 0.28 inch (7 mm) of bare wire.
2. Insert the wire into a terminal connector.
3. Tighten the terminal screw to 0.5 to 0.6 N-m (71 to 85 ozf-in or 4.4 to 5.3 lbf-in.)
4. Tug on the wires after tightening the screws to ensure all wires are secure.

BACnet® MS/TP Communication Link

For more details about BACnet MS/TP communication link, refer to the *BACnet MS-TP Wiring and Link Performance Best Practices and Troubleshooting Guide* (BAS-SVX51*-EN).

⚠ WARNING

Proper Field Wiring and Grounding Required!

Failure to follow code could result in death or serious injury.

All field wiring MUST be performed by qualified personnel. Improperly installed and grounded field wiring poses FIRE and ELECTROCUTION hazards. To avoid these hazards, you MUST follow requirements for field wiring installation and grounding as described in NEC and your local/state/national electrical codes.

BACnet/IP Over Wired Ethernet Communications

Wired Ethernet is only an option on the Symbio 500 controller. Use daisy chain, star, or ring topologies.

Air-Fi Wireless BACnet® Communications

Symbio 500 can communicate wirelessly to the Trane Tracer SC+ and zone sensors through the Trane Air-Fi Wireless system (BACnet/Zigbee). Wireless Air-Fi communications are the preferred method of communicating to the SC+. Trane Air-Fi is a factory or field installed option.

See *Air-Fi® Wireless System Installation, Operation, and Maintenance* (BAS-SVX40*-EN) for detailed information.

Wiring Guidelines for Wired BACnet MS/TP

- Use 18 AWG Trane purple-shielded communication wire for BACnet installations.
- Link limit of 4,000 ft and 60 devices maximum (without a repeater).
- Use a Trane BACnet termination on each end of the link.
- Use daisy chain topology.
- Maintain polarity.

Figure 4. BACnet MS/TP link wiring — zone sensors are not required with this application

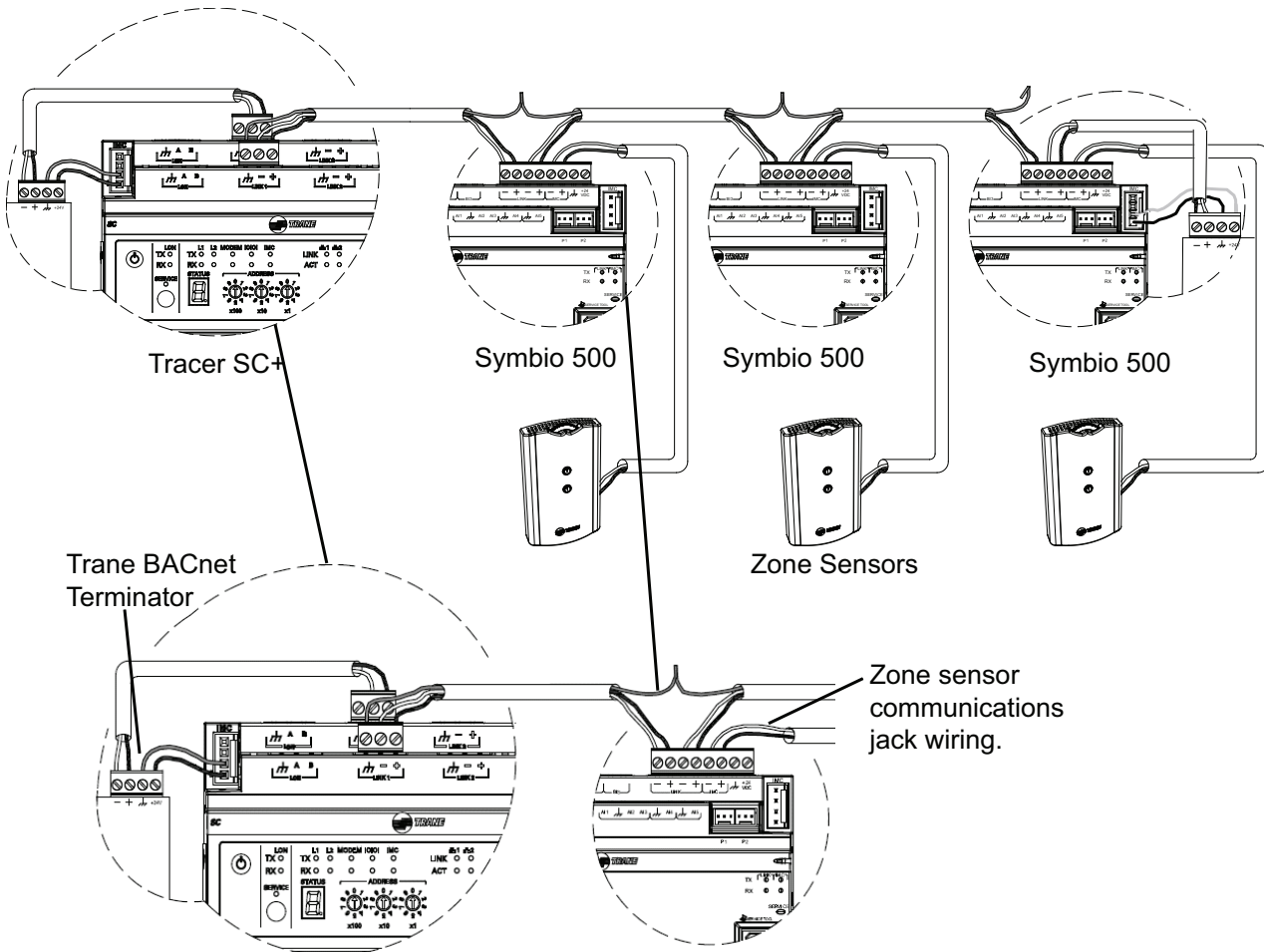

Wiring Best Practices

To ensure proper network communication, follow the recommended wiring and best practices below when installing communication wire:

- All wiring must comply with the National Electrical Code™ (NEC) and local codes.
- Ensure that 24 Vac power supplies are consistent in regards to grounding. Avoid sharing 24 Vac between controllers.
- Avoid over tightening cable ties and other forms of cable wraps. This can damage the wires inside the cable.
- Do not run communication cable alongside or in the same conduit as 24 Vac power. This includes the conductors running from TRIAC-type inputs.
- In open plenums, avoid running wire near lighting ballasts, especially those using 277 Vac.
- Use same communication wire type, without terminators, for the zone sensor communication stubs from the Symbio 500 controller IMC terminals to the zone sensor communication module.
- Zone Sensor communication wiring length limits of 300 ft. (100 m).

Setting Up the Controller on a BACnet Link

Observe the following when setting up the Symbio 500 controller on a BACnet link.

- Use 18 AWG shielded communication wire for BACnet MS/TP installations.
- Limit BACnet MS/TP wiring links to 4,000 ft. There is a maximum of 60 devices per link (*without a repeater*).
- Three (3) BACnet links are available on the Tracer SC+.

- Connect the BACnet link to the Symbio 500 controller terminals labeled *Link* as shown on the right. Incoming wires can be connected to the first two terminals, and the outgoing wires can be connected to the second set of terminals, so there is only one wire per termination.

Figure 5. Symbio 500 BACnet links

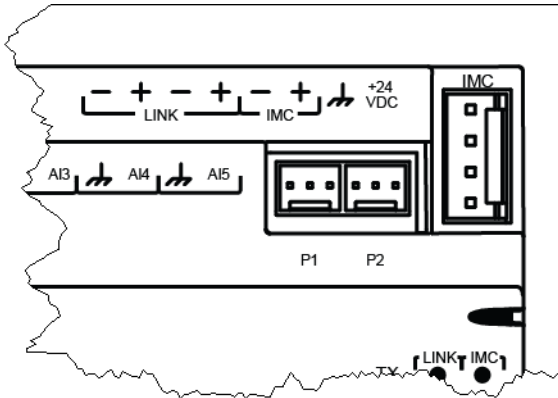

Setting the Address

The three (3) rotary address dials on the Symbio 500 serve one or two purposes depending upon the network: they are always used for the MAC Address, which is sometimes all or part of the BACnet Device ID.

Figure 6. Setting the rotary address

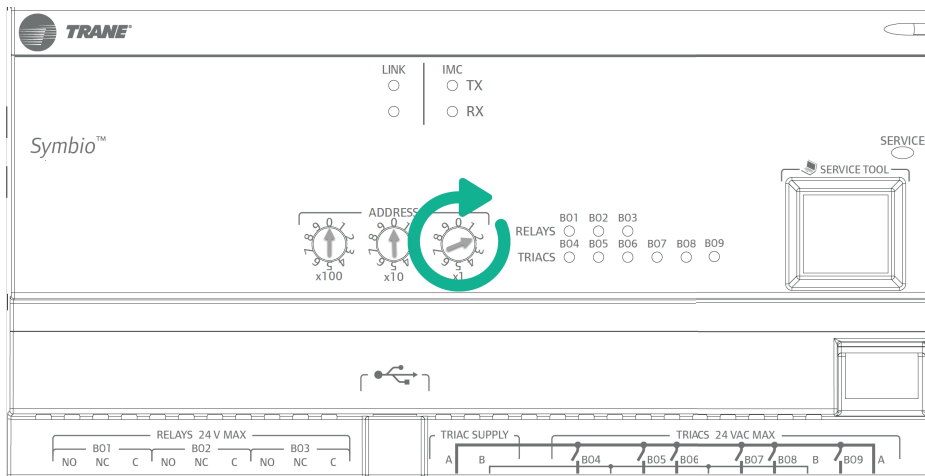

Use a 1/8 inch (3.2 mm) flathead screwdriver to set rotary address dials. These dials rotate in either direction.

MAC Address

The MAC Address is required by the RS-485 communication protocol on which BACnet operates. Valid MAC addresses are 001 to 127 for BACnet.

Important: Each device on the link must have a unique MAC Address/Device ID. A duplicate address or a 000 address setting will interrupt communications and cause the Tracer SC+ device installation process to fail.

BACnet Device ID

The BACnet Device ID is required by the BACnet network. Each device must have a unique number from 001 to 4094302.

BACnet Networks Without a Tracer SC+ System Controller

On BACnet networks without a Tracer SC+ system controller, the Device ID can be assigned one of two ways:



Wiring

- It can be the same number as the MAC Address, determined by the rotary address dials on the Symbio 500 controller. For example, if the rotary address dials are set to 042, both the MAC Address and the BACnet Device ID are 042, **OR**
- It can be soft set using Tracer TU service tool. If the BACnet Device ID is set using Tracer TU service tool, the rotary address dials only affect the MAC Address, they do not affect the BACnet Device ID.

BACnet Networks With a Tracer SC+ System Controller

On BACnet networks with a Tracer SC system controller, the Device ID for the Symbio 500 controller can be soft set by the system controller using the following scheme.

Note: The BACnet Device ID is displayed as the Software Device ID on the Tracer TU Controller Settings Page in the Protocol group.

Device ID Assignment for BACnet MS/TP Devices

Each unit controller must have a unique BACnet device ID. Tracer SC+ automates the process by calculating a unique device ID for each unit controller and then saving the device ID to memory in each device. BACnet MS/TP device IDs are calculated using the following three sets of values:

- The Tracer SC+ rotary switch value (1 to 419)
- The Tracer SC+ BACnet MS/TP link number (1 to 3)
- The unit controller rotary switch value (1 to 127)

The three values are joined together to form the BACnet device ID for the unit controller as shown in the following table.

Table 3. Calculating the BACnet Device ID

Tracer SC+ rotary switch value (21)	0	2	1				
Tracer SC+ BACnet MS/TP link number (1)				1			
Unit controller MAC address (38)					0	3	8
BACnet Device ID: 211038	0	2	1	1	0	3	8

Ethernet

The Symbio 500 controller has two Ethernet ports. The ports, labelled 1 and 2, are internally connected as one port. These ports enable wired BACnet/IP or support for the TD7 display.

For more information on BACnet/IP wiring see *BACnet®/IP Wiring and Best Practices Application Guide* (BAS-APG046*–EN).

Example Application: Dual Duct VAV where wired BACnet/IP is specified.

Figure 7. Symbio 500 Ethernet ports

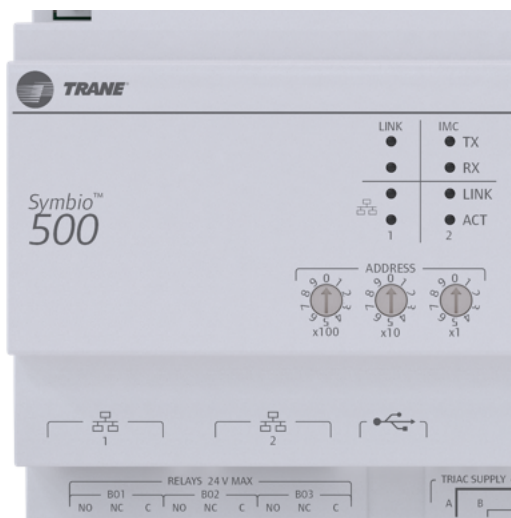

Power Supply

⚠ WARNING

Hazardous Voltage!

Failure to disconnect power before servicing could result in death or serious injury.

Disconnect all electric power, including remote disconnects before servicing. Follow proper lockout/tagout procedures to ensure the power can not be inadvertently energized. Verify that no power is present with a voltmeter.

⚠ WARNING

Proper Ground Connection Required!

Failure to follow instructions below could result in death or serious injury.

After installation, ensure that the 24 Vac transformer is grounded through the controller. Measure the voltage between chassis ground and any ground terminal on the controller. Expected result: Vac <4.0 volt.

NOTICE

Equipment Damage!

Sharing 24 Vac power between controllers could result in equipment damage.

A separate transformer is recommended for each Symbio 500 controller. The line input to the transformer must be equipped with a circuit breaker sized to handle the maximum transformer line current. If a single transformer is shared by multiple Symbio 500 controllers:

- The transformer must have sufficient capacity.
- Polarity must be maintained for every Symbio 500 controller powered by the transformer.
Important: If the polarity is inadvertently reversed between two controllers powered by the same transformer, a difference of 24 Vac will occur between the grounds of each controller, which can result in:
 - Partial or full loss of communication on the entire BACnet MS/TP link.
 - Improper function of Symbio controller outputs.
 - Damage to the transformer or a blown transformer fuse.

Transformer Recommendations

The Symbio 500 controller can be powered with 24 Vac or 24 Vdc. You must use a 24 Vac power supply for proper operation of the binary inputs, which require 24 Vac detection, and also to use the spare 24 Vac outputs to power relays and TRIACS.

- **AC transformer requirements:** UL listed, Class 2 power transformer, 24 Vac \pm 15%, device max load 24 VA, BCI application 6 VA. The transformer must be sized to provide adequate power to the controller (21 VA) and outputs (maximum of 10A per relay output and 0.5A per TRIAC output).
- **DC power supply requirements:** UL listed, Class 2 power supply, 24 Vdc \pm 15%, device max load 420 mA, BCI application 90 mA.
- **CE-compliant installations:** The transformer must be CE marked and SELV compliant per IEC standards.

Wiring Recommendations

To ensure proper operation of the Symbio 500 controller, install the power supply circuit in accordance with the following guidelines:

- The controller must receive AC power from a dedicated power circuit; failure to comply may cause the controller to malfunction.
- A dedicated power circuit disconnect switch must be near the controller, easily accessible by the operator, and marked as the disconnecting device for the controller.
- DO NOT run AC power wires in the same wire bundle with input/output wires; failure to comply may cause the controller to malfunction due to electrical noise.
- 18 AWG (0.823 mm²) copper wire is recommended for the circuit between the transformer and the controller.



Wiring

Connecting Wires

Disconnect power to the transformer and then ground one of the terminals on the controller to the enclosure (if the enclosure is adequately grounded) or to an alternate earth ground.

Figure 8. Symbio 500 transformer

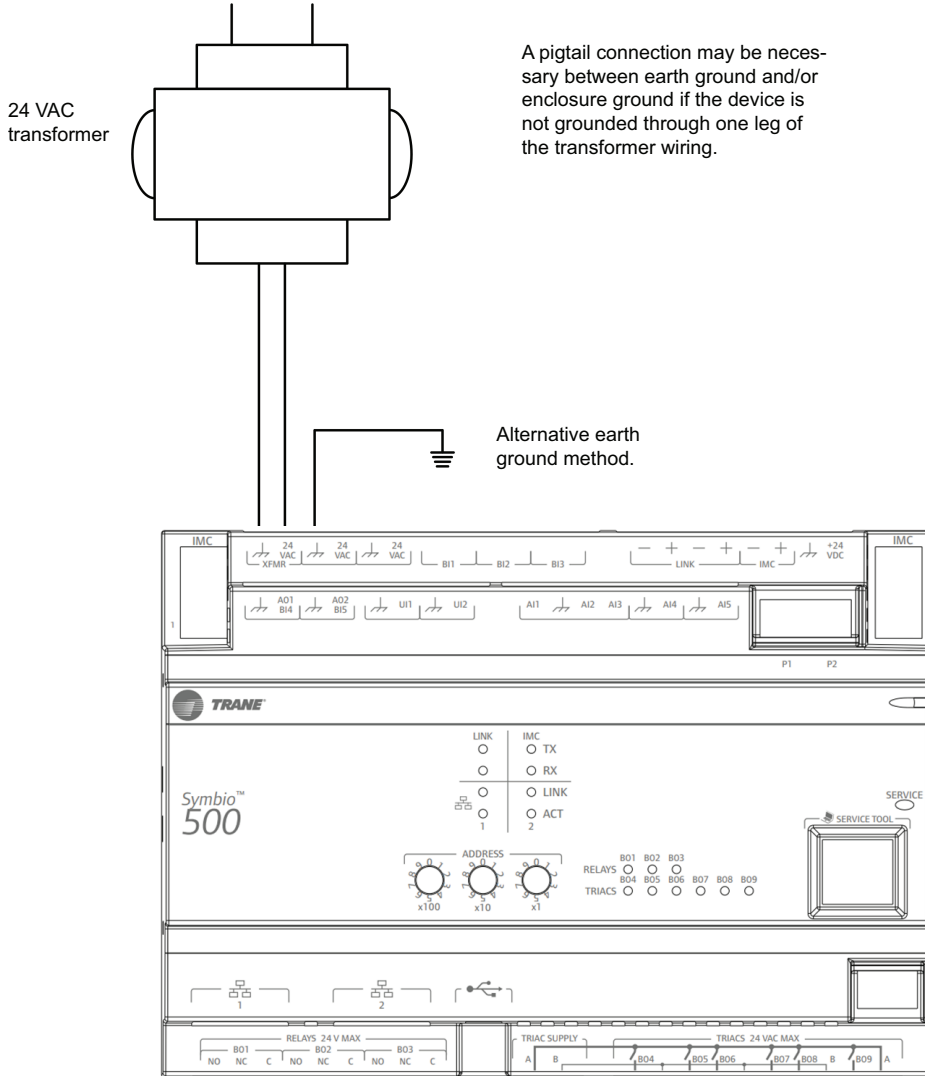

Power On Check

1. Verify that the 24 Vac connector and the chassis ground are properly wired.
2. Remove the lockout/tagout from the line voltage power to the electrical cabinet.
3. Energize the transformer to apply power to the Symbio controller.
4. Observe the Symbio controller when power is applied to verify the power check sequence:
 - a. The power LED lights red for 1 second.
 - b. The power LED lights green.
 - c. If the sequence completes as described, the controller is properly booted and ready for the application code.
 - d. If the power LED flashes red, a fault condition exists.

Inputs/Outputs

Pre-Power Checks

Before connecting any inputs/outputs to the Symbio 500 controller, perform the following pre-power checks.

Basic Checks

For devices with input/output types listed below, verify their basic functionality:

- Binary inputs: check that they are opening and closing. Also check for 24 Vac if they provide their own power. With a Trane-provided 24 Vac, check to make sure it is dry contact and working.
- Thermistors: check for 10K using a digital multimeter (DMM).
- Thumb wheels: verify mechanical operation.
- Binary outputs: check for any dead shorts.
- Analog outputs: check that no A/C voltage is present and that the load has no 24 Vac across it or 120 Vac.

Point Check Diagram

This section shows diagrams and describes methods to check device input/output points before the connection to the Symbio 500 controller has been made and power has been applied. The step numbers in each illustration correspond to the information in each table.

Note: The Symbio 500 controller should not be connected to the input and output devices during the pre-power checks, so the controller is not shown in the diagrams.

Resistive Inputs

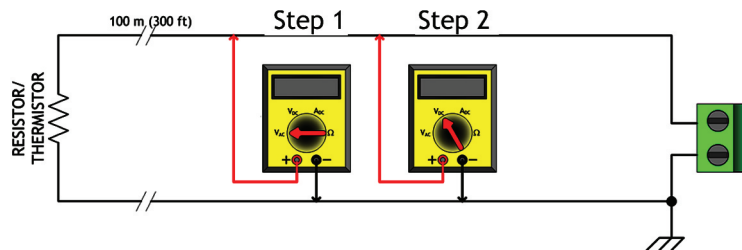

Checkout Procedure	Measurement	Expected Value
Step 1	Measure AC voltage across the resistive termination.	Vac ≈ 0.0 V AC voltage will affect further measurement.
Step 2	Measure DC voltage across the resistive termination.	Vdc ≈ 0.0 V DC voltage will affect further measurement.
Step 3	Measure the resistance across the resistive termination.	Compare the measured resistance with the expected value based on the manufacturer's specification and current conditions.

Voltage Inputs

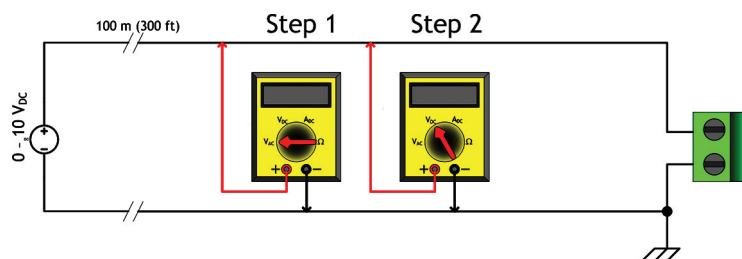

Wiring

Checkout Procedure	Measurement	Expected Value
Step 1	Measure AC voltage across the voltage input.	$V_{ac} \approx 0.0 \text{ V}$ AC voltage will affect further measurement.
Step 2	Measure DC voltage across the voltage termination.	Compare the measured voltage with the expected value based on the manufacturer's specification and current conditions.

• Current Inputs

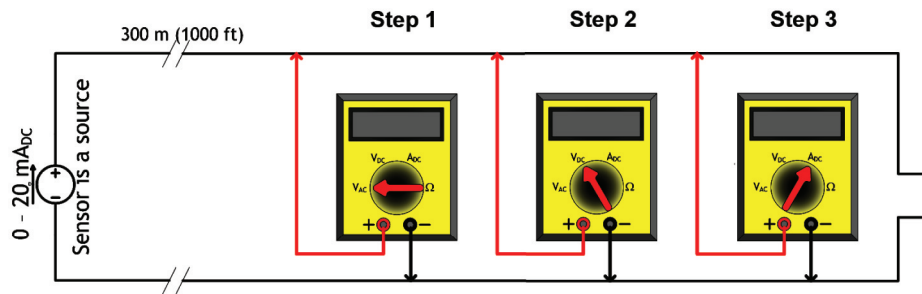

Checkout Procedure	Measurement	Expected Value
Step 1	Measure AC voltage across the current input.	$V_{ac} \approx 0.0 \text{ V}$ AC voltage will affect further measurement.
Step 2	Measure DC voltage across the current input.	$V_{dc} \approx 0.0 \text{ V}$
Step 3	Measure the DC current across the current input.	Compare the measured current with the expected value based on the manufacturer's specification and current conditions.

• Binary Inputs, 24 Vac Detect

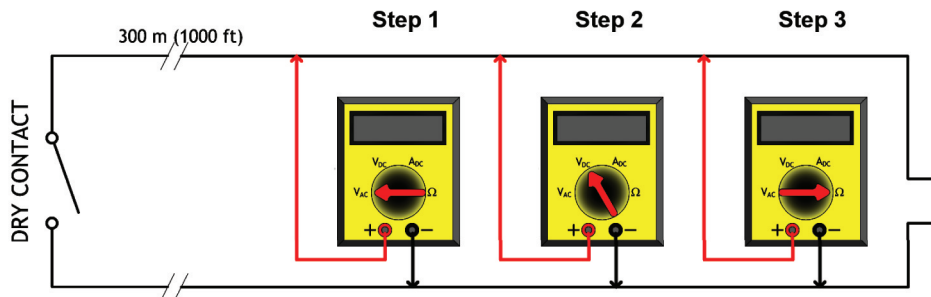

Checkout Procedure	Measurement	Expected Value
Step 1	Measure AC voltage across the resistive termination.	$V_{ac} \approx 0.0 \text{ V}$ AC voltage will affect further measurement.
Step 2	Measure DC voltage across the resistive termination.	$V_{dc} \approx 0.0 \text{ V}$ DC voltage will affect further measurements.
Step 3	Measure the resistance across the resistive termination.	

• Binary Inputs Based On Analog Output Connection

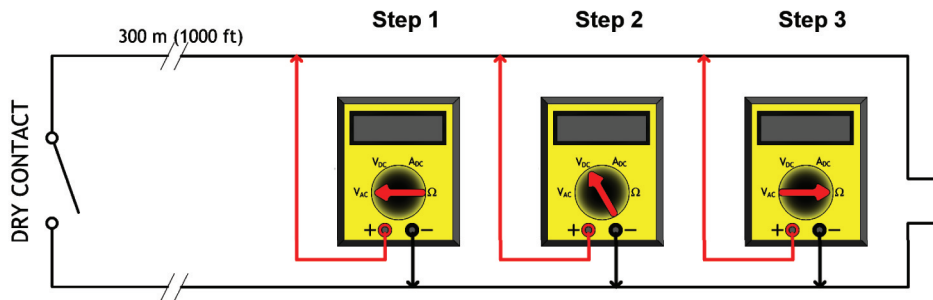

Checkout Procedure	Measurement	Expected Value
Step 1	Measure AC voltage across the resistive termination.	Vac ≈ 0.0 V AC voltage will affect further measurement.
Step 2	Measure DC voltage across the resistive termination.	Vdc ≈ 0.0 V DC voltage will affect further measurements.
Step 3	Measure the resistance across the resistive termination.	

Wiring Requirements

NOTICE

Equipment Damage!

Failure to follow instructions below could result in damage to the controller, power transformer, or input/output devices due to inadvertent connections to power circuits.

Remove power to the controller before making input/output connections.

Maximum Wire Lengths		
Type	Inputs	Outputs
Binary	1,000 ft (300 m)	1,000 ft (300 m)
0–20 mA	1,000 ft (300 m)	1,000 ft (300 m)
0–10 Vdc	300 ft (100 m)	300 ft (100 m)
Thermistor/Resistive	300 ft (100 m)	Not Applicable

Notes:

- All wiring must be in accordance with the NEC and local codes.
- Use only 18–22 AWG (1.02 mm to 0.65 mm diameter), stranded, tinned-copper, shielded, twisted-pair wire. Shielding is optional for binary inputs and analog 0 - 20 mA inputs.
- 24 Vdc output wiring distances are dependent on the receiving unit specifications. Output wiring must comply with the receiving unit's wiring specifications.
- DO NOT run input/output wires or communication wires in the same wire bundle with AC power wires.

Providing Low-voltage Power for I/Os

The Symbio 500 controller can provide low-voltage power to the inputs/outputs. More than one input or output can receive power from a given screw terminal as long as the total amount of power consumed does not exceed the terminal's limit. The Symbio controller requires 24 Vac, UL-listed, Class 2 power transformer. This section provides information about checking power budget consumption for the Symbio controller in an un-powered state.

Calculating Power Consumption Rules

- Total available power is determined by the transformer rating. Use the following table as a guideline for the Symbio controller power consumption.
- Reserve 12 VA to power XM30 expansion modules.
- The total of the 24 Vac output and inputs should not exceed the remaining power. Refer to the following table for Power Budgets.



Wiring

Item	Sub ^(a)	VA Draw Per I/O (24 Vac)	Maximum Total VA Draw (24 Vac)
Symbio 500 Board	Symbio controller (No input/output)		8 VA
	5 x AI	0.2 VA per AI	1 VA
	2 x UI	0.13 VA per UI	0.25 VA
	2 x PI	0.13 VA per PI	0.25 VA
	3 x BI	0.17 VA per BI	0.5 VA
	2 x AO	1 VA per AO	2 VA
	3 x BO (relay)	1 VA per relay (no load)	3 VA
	6 x BO (TRIAC)	0.34 VA per TRIAC (no load)	1 VA
	Subtotal for controller		
24 Vdc Supply	200 mA ^(b)	1 VA per 25mA DC	8 VA
	Total for controller		24 VA
Binary Outputs- Relay and TRIAC			
BO1 to BO3	Relay	Refer to the Device Connections table.	Refer to the Device Connections table.
BO4 to BO9	TRIAC	0.5 A - 12 VA@ 24 Vac	12 VA Maximum

^(a) A: amp, AI: analog input, AO: analog output, BI: binary input, BO: binary output, PI: pressure input, UI: universal input, VA: voltage ampere, Vac: volts alternating current, Vdc: volts direct current

^(b) Expansion Modules: If all analog outputs are configured for current and the devices are powered at the maximum current draw, then the XM30 maximum current draw is 115 mA. Do not exceed the Symbio 500 controller 200 mA output limit.

Terminal Locations

NOTICE

Equipment Damage!

Failure to follow instructions below could result in damage to the controller, power transformer, or input/output devices due to inadvertent connections to power circuits.

Remove power to the controller before making input/output connections.

Figure 9. Terminal locations

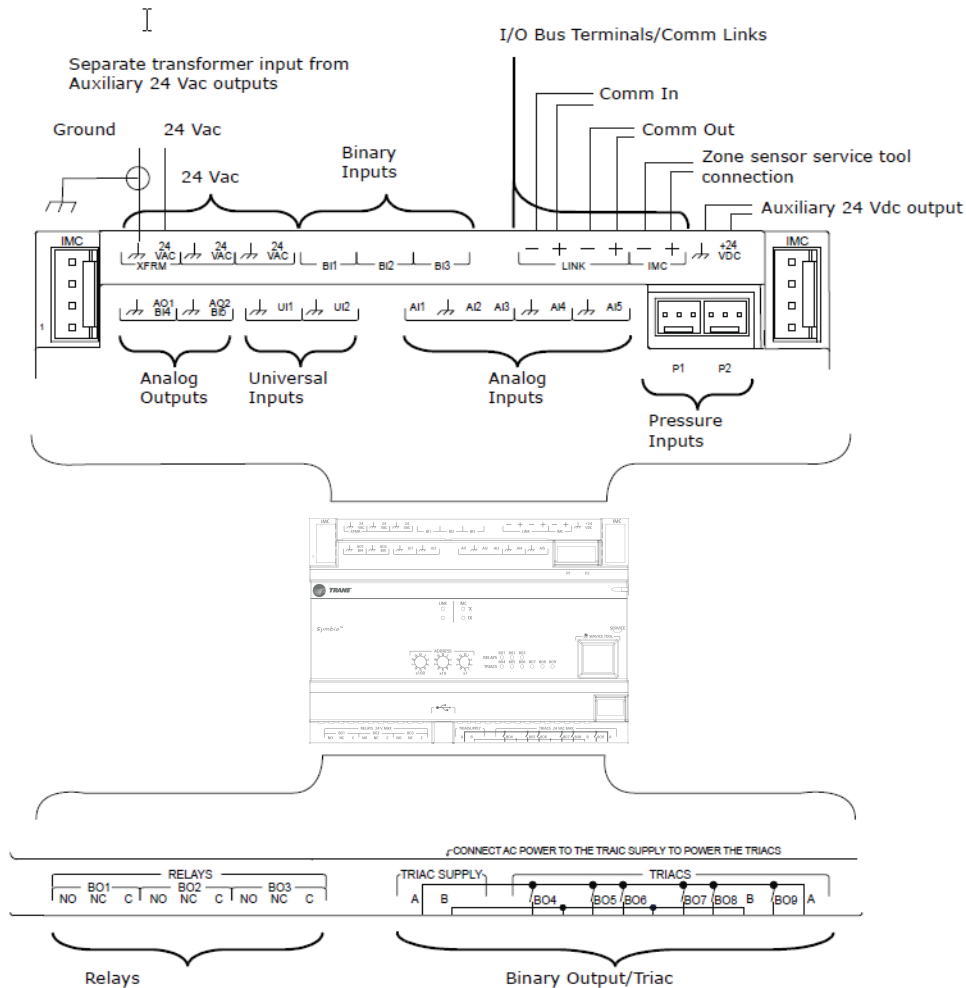

Note: The screw terminal blocks are not shown in this illustration, but they must be inserted before you can connect wires to the identified terminal locations.

Pressure Transducer Inputs

The pressure inputs P1 and P2 (shown in previous figure) are designed for 3-wire pressure sensor transducers, specifically Kavlico™ brand, which require 5 Vdc input.

Important: If using a different brand of pressure sensor transducer, contact Trane for help ensuring proper operation.

- P1 is typically used alone in single-duct applications when only one pressure measurement is needed.
- P1 and P2 are typically used together in dual-duct applications when two pressure measurements are needed. Examples include dual-duct VAV control and duct pressure measurement.

Binary Inputs

Connect to the binary inputs to monitor statuses such as fan on/off or alarm resets. The illustration below shows a typical wiring for binary inputs to either UI or BI terminals.

Figure 10. Binary inputs

If using a universal input terminals configured as a binary input (shown using 2-wire with shielding)

If using binary input terminals (shown using 2-wire without shielding)

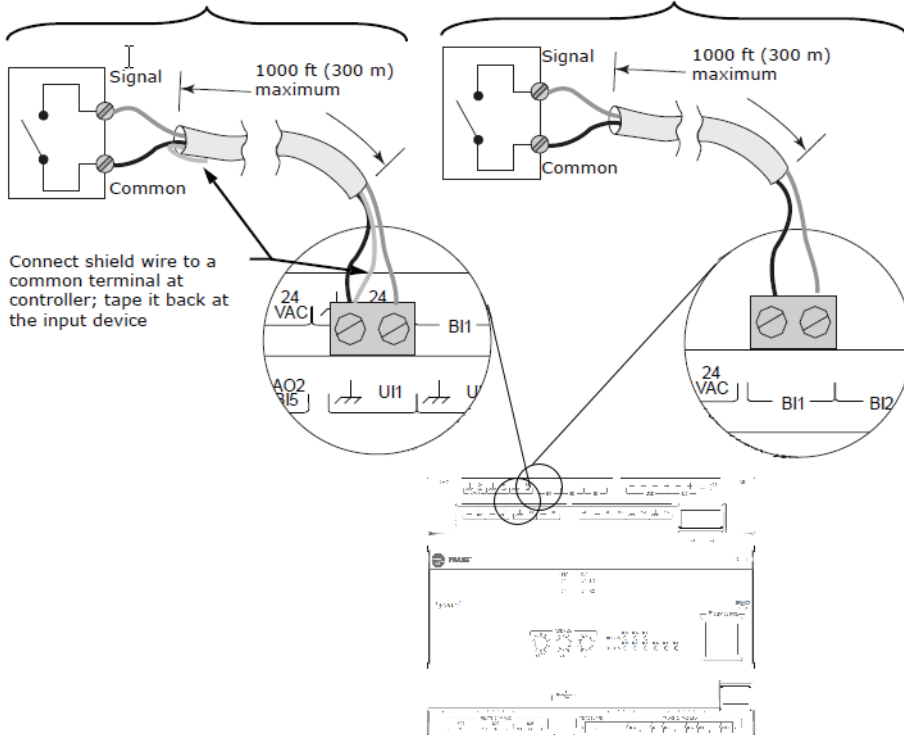

Note: Polarity is normally open (NO) or ON. However, you can use the Polarity control (toggle) on the Binary Input Point Configuration dialog box to reverse polarity to normally closed (NC) or OFF. For example, you might reverse polarity when using a binary input with a freeze stat to open the contacts to shut off power when a temperature declines to a given setpoint. Access the Point Configuration dialog box from either the Tracer TU Controller Settings Utility Binary point list screen or the right-click menus on the Tracer TU Status Utility Binary point list screen.

1. Connect the common wire to a common terminal as shown below.
Note: Because the common terminals are in parallel, wiring can be made to any common terminal.
2. Connect the shield wire (if present) to a common terminal at the termination board and tape it back at the input device.
3. Connect the signal wire to an available input terminal.
4. Use the Tracer TU service tool to configure the input for binary operation.

0–10 Vdc Analog Inputs

The two universal inputs can be used to receive a 0–10 Vdc analog signal from sensors such as indoor air quality sensors and pressure sensors. The illustration below shows a typical wiring for analog inputs, 0–10 Vdc.

Figure 11. 0–10 Vdc analog inputs

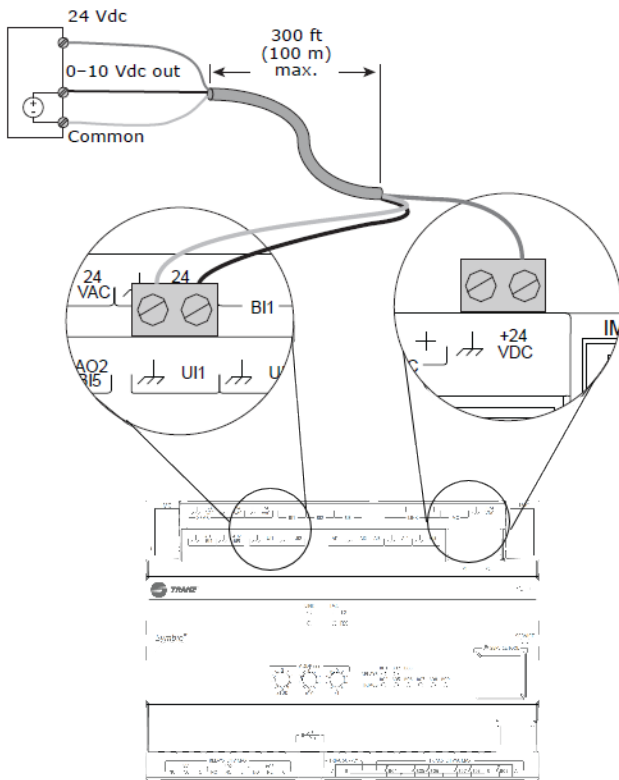

To wire a 0–10 Vdc analog input:

1. Connect the shield wire (as common connection) to a common terminal.
2. Connect the signal wire to an available input terminal.
3. Connect the supply wire to a 24 Vdc or 24 Vac terminal as required.
4. Use the Tracer TU service tool to configure the universal input for analog operation.

0–20 mA Analog Inputs

The universal inputs can be used to receive a 0–20 mA analog signal from sensors such as humidity sensors and pressure sensors. The illustration below shows a typical wiring for analog inputs, 0–20 Vdc.

Figure 12. 0–20 mA analog inputs

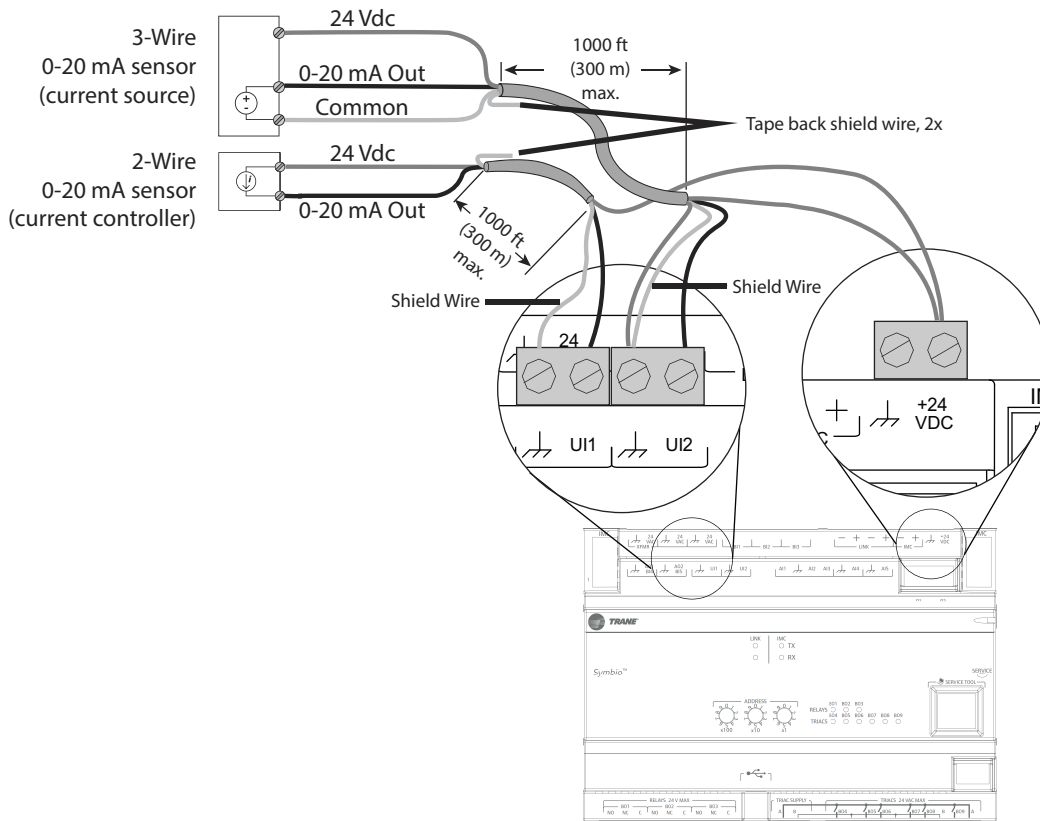

To wire a 0–20 mA analog input:

1. Connect the shield to a common terminal at the terminal board and tape it back at the input device.
 - Note:** Do not use the shield as the common connection. For 3-wire applications, use a 3-conductor cable with shield and for 2-wire applications, use a 2-conductor cable with separate shield.
2. Connect the signal wire to an available universal input terminal.
3. Connect the supply wire to a 24 Vdc or 24 Vac terminal as required.
4. Use the Tracer TU service tool to configure the universal input for analog operation.

Variable Resistance Analog Inputs

Variable resistance analog inputs include 10K thermistors, resistive, and setpoint thumb wheels on zone sensors. The illustration below shows a typical wiring for analog inputs, variable resistance.

Figure 13. Variable resistance analog inputs

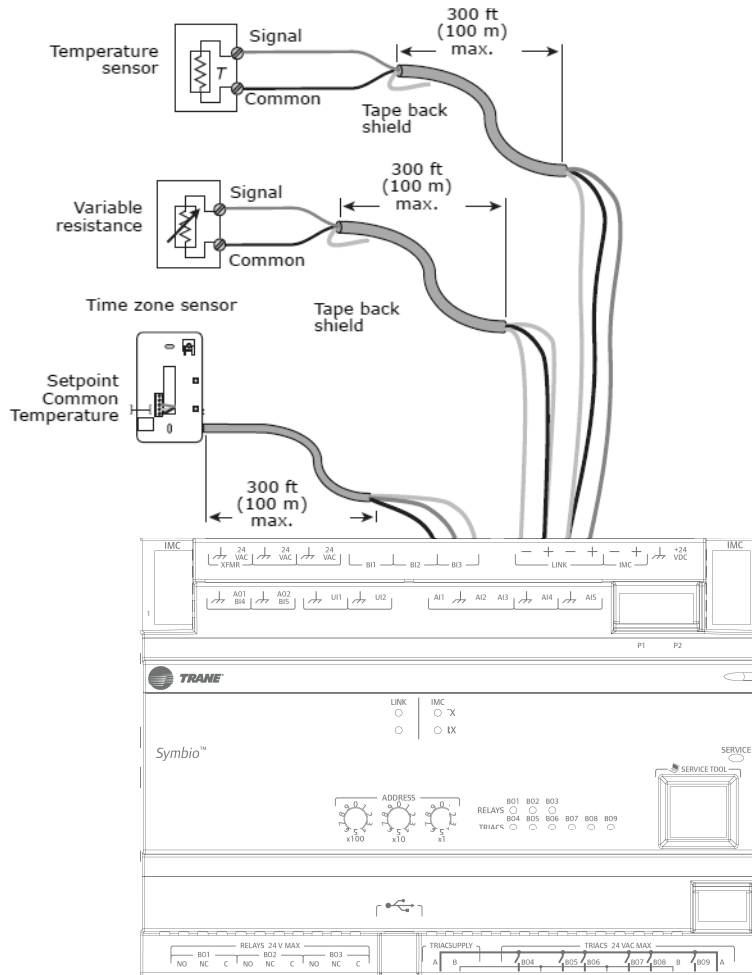

(a) For Comm+/- wiring, use 18 AWG, shielded, twisted-pair wire.

1. Connect the shield to a common terminal at the terminal board and tape it back at the input device.
Note: Do not use the shield as the common connection. For 3-wire applications, use a 3-conductor cable with shield and for 2-wire applications, use a 2-conductor cable with separate shield.
2. Connect the signal wire to an available input terminal.
3. Use the Tracer TU service tool to configure the input for analog operation.

Analog Outputs

The Symbio 500 has two analog outputs. These outputs can be used for 0–10 Vdc outputs or 0–20 mA outputs, which can control actuators or secondary controllers. Output wiring specifications must comply with the receiving device wiring requirements. The illustration below shows a typical wiring for analog outputs.

Figure 14. Analog outputs

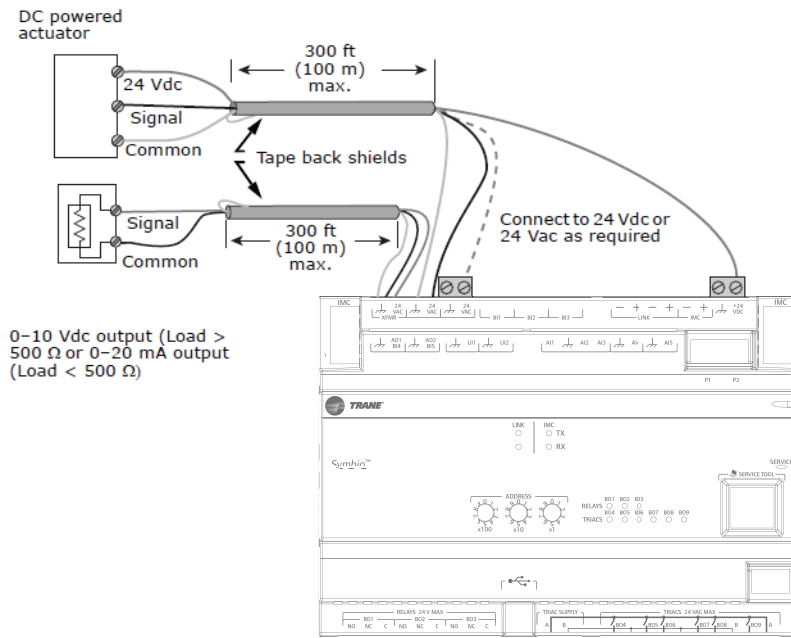

1. Connect the shield to a common terminal at the terminal board and tape it back at the input device.
Note: Do not use the shield as the common connection. For 2-wire applications, use a 2-conductor cable with separate shield.
2. Connect the signal wire to an available output terminal.
3. Connect the supply wire to a 24 Vdc or 24 Vac terminal as required.
4. Use the Tracer TU service tool to configure the input for analog operation.

Relay (Dry Contact/Binary Outputs)

The Symbio 500 has three relay binary outputs used as powered outputs. All outputs are isolated from one another and from the ground and power. The illustration below shows a typical wiring for relays, binary outputs.

Figure 15. Dry contact/binary outputs

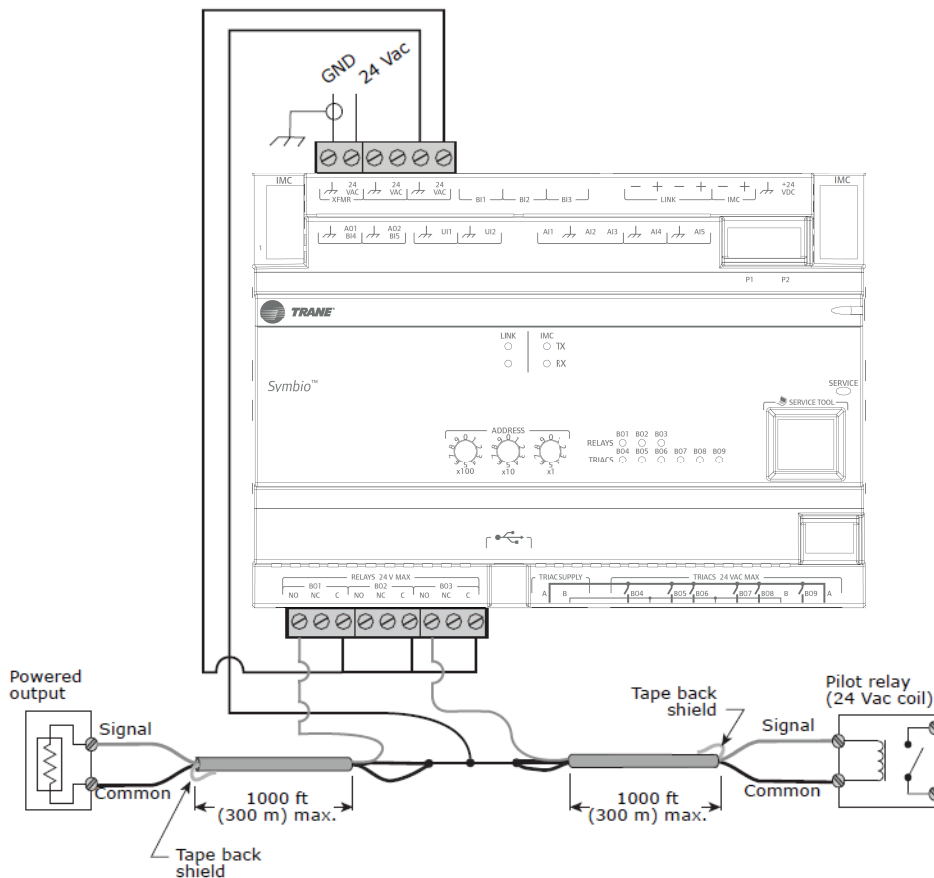

Note: Output wiring specifications must comply with the receiving device wiring requirements.

Important: Inrush Current and Controlling Coil-based Loads: Inrush current (the initial surge of a current into a load before it attains normal operating condition) can be more than three times greater than the operating current.

Use pilot relays for dry contact outputs for load currents greater than 0.5 amperes and use powered outputs for load currents less than 0.5 amperes.

To wire relay binary outputs:

1. Connect the shield to a common terminal at the terminal board and tape it back at the output device.
2. Connect the signal wire to an available output terminal.
3. Use the Tracer TU service tool to configure the input for binary operation.

Note: Polarity is normally open (NO) or ON. However, you can use the Polarity control (toggle) on the Binary Output Point Configuration dialog box to reverse polarity to normally closed (NC) or OFF.

TRIAC Wiring

The Symbio 500 has six (6) TRIAC binary outputs. The following illustrations show wiring to TRIAC binary outputs (low/high).

Figure 16. TRIAC wiring

Low Side Switching

Note: The benefit of using low side switching is to minimize the risk of burning up binary outputs due to inadvertent shorts to the ground.

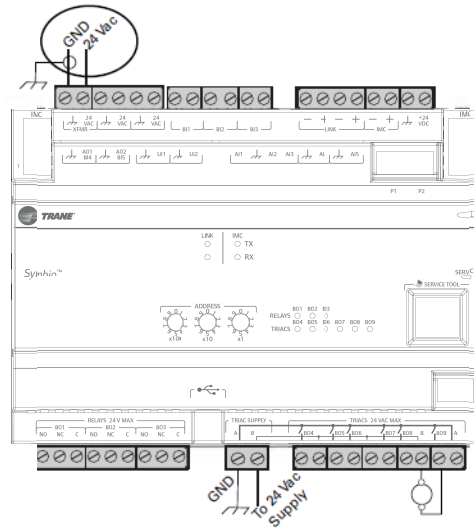

High Side Switching

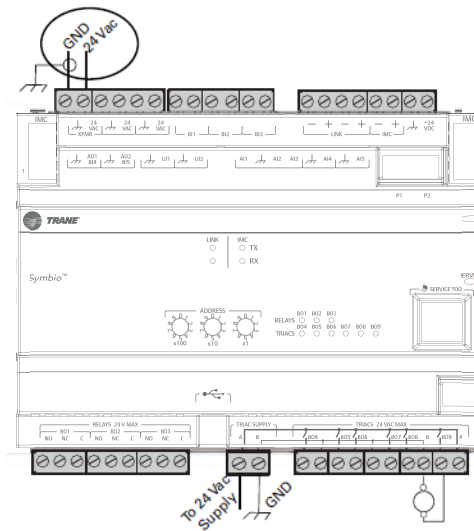



Operation

LED Locations

The Symbio controllers have the following LEDs located on the front (refer to the following illustration):

- Marquee LED
- Communication Status LEDs and IMC Status LEDs
- Service Button LED
- Binary Output Relay (3)/TRIAC (9) Status LEDs

Figure 17. Symbio 500 LED locations

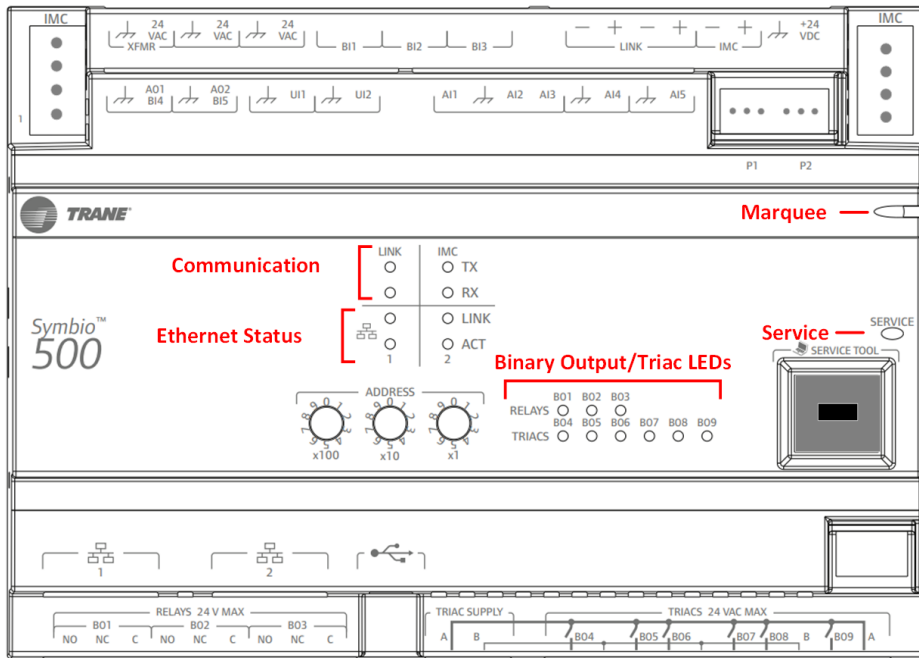

LED Descriptions, Activities, and Troubleshooting

The following table provides a description of LED activity, an indication or troubleshooting tip for each, and any relative notes.

Table 4. LED activities and troubleshooting tips

LED Name	Activities	Indication and Troubleshooting Tips	Notes
Marquee LED	Shows solid green when the unit is powered and no alarm exists.	Indicates normal operation	When powering the Symbio 400–B/500 and expansion module, the Marquee LED will blink RED, blink GREEN (indicating activated and controller/expansion module are communicating), and then stay GREEN CONTINUOUSLY (indicating normal power operation).
	Shows blinking green during a device reset or firmware download.	Indicates normal operation	
	Shows solid red when the unit is powered, but represents low power or a malfunction.	<ul style="list-style-type: none"> If low power; could be under voltage or the microprocessor has malfunction. Follow the troubleshoot procedure “24 Vac Measurement,” p. 46 to measure for the expected value range. In addition, see Table 4, p. 24, for a list of 24 Vac draws. If malfunction; un-power and then re-power unit to bring the unit back up to normal operation. 	
	Shows blinking red when an alarm or fault exists.	An alarm or fault condition will occur if the value for a given point is invalid or outside the configured limits for the point. Alarm and fault conditions vary, and they can be configured by the programmer.	
	LED not lit.	Indicates power is OFF or there is a malfunction. OFF or malfunction; cycle the power.	
Link and IMC	TX blinks green.	Blinks at the data transfer rate when the unit transfers data to other devices on the link.	TX LED: Regardless of connectivity or not, this LED will constantly blink as it continually looks for devices to communicate to. LED not lit: Determine if, for example, a Tracer Synchrony or BACnet device is trying to talk to the controller or if it is capable of talking to the controller. Also determine if the communication status shows down all of the time. In addition, check polarity and baud rate.
	RX blinks yellow.	Blinks at the data transfer rate when the unit receives data from other devices on the link. ON solid yellow; indicates there is reverse polarity.	
	LED is not lit.	Indicates that the controller is not detecting communication. Not lit; cycle the power to reestablish communication.	
Service	Shows solid green when the LED has been pressed.		When the Symbio 400–B/500 is placed into boot mode, the system will not run any applications such as trending, scheduling, and TGP2 runtime. The controller will be placed into boot mode if the service pin is held in when power is applied. In boot mode, the controller is non-operational and is waiting for a new main application to be downloaded.
	LED not lit.	Indicates controller is operating normally.	

Table 4. LED activities and troubleshooting tips (continued)

LED Name	Activities	Indication and Troubleshooting Tips	Notes
Binary B01 through B09	Shows solid yellow.	<p>Indicates a corresponding binary output has been commanded ON</p> <ul style="list-style-type: none"> Relay coil; indicates that a command has been made to energize TRIAC; indicates that a command has been made to turn ON. 	<p>If the user is currently powering the Symbio 400-B/500 from a USB port, the Led lights will turn ON. However, the binary outputs will not be activated.</p> <p>Commanded ON; As an example of commanded ON, a command could be a manual command such as an override or a command could be from TGP2 based on a list of conditions that are met telling these outputs to turn ON.</p>
	LED not lit.	<p>Indicates that a relay output is de-energized or no power to the board</p> <p>Not lit; cycle power to reestablish communication.</p>	<p>LED not lit: Did the user command it to be ON? If yes, see the Marquee LED at the top of this table.</p>

Marquee LED Status and Error Codes

Each of the following codes is a two digit number following this pattern: First digit, 600mS pause, Second digit, 2 second pause and then repeat the pattern.

Table 5. Marquee LED status and error codes

LED Blink Pattern	Message	Description	Action by User
Green LED Blink Pattern			
Solid green light	No active alarms or messages		None - normal operation
11	Load Field	Attempting to load the field kernel and device tree from NAND flash.	None- normal operation
13	Boot Field	Successfully loaded the field images and are attempting to boot.	None- normal operation
14	Load Recover	Attempting to load the recover image from NAND flash.	None- normal operation
16	Boot Recover	Successfully loaded the recovery image and are attempting to boot.	None- normal operation
17	Recovery	Successfully booted into the recovery partition.	None- normal operation
23	Field Format	Reformatting the field file system.	None- normal operation
28	Starting Update	Starting the firmware update process.	None- normal operation
29	Locating Firmware File	Attempting to locate a firmware update file.	None- normal operation
33	Validating Firmware	Validating the signature on the firmware update file.	None- normal operation
35	Decrypting Firmware	Decrypting the firmware update file.	None- normal operation
36	Update Success	Done performing the firmware update.	None- normal operation
37	Clearing Database	Clearing the database.	None- normal operation
38	Validating Firmware	Validating the signature on the firmware update file.	None- normal operation
41	Decrypting Firmware	Decrypting the firmware update file.	None- normal operation
43	Restoring Backup	Restoring a database backup.	None- normal operation
45	Force Database Clear	The user has 30 seconds to set the rotaries to something other than 9-9-9 to start the process of returning to factory defaults.	None- normal operation
46	Clear Done	Done returning the database to factory defaults.	None- normal operation



Operation

Table 5. Marquee LED status and error codes (continued)

LED Blink Pattern	Message	Description	Action by User
47	Done	Done returning whatever process was started (usually a forced recovery partition update).	None- normal operation
51	Backup Retored	Database backup has been restored.	None- normal operation
52	Updating Firmware	Updating the firmware.	None- normal operation
53	Firmware Updated	Firmware was updated.	None- normal operation
55	Updating Firmware	Firmware is currently being updated.	None- normal operation
56	Updating Kernel	The kernel is currently being updated.	None- normal operation
58	Updating Device Tree	The kernel is currently being updated.	None- normal operation
61	Updating Bootloader	The bootloader is being updated.	None- normal operation
63	Updating Recovery	The recovery file system is being updated.	None- normal operation
Red LED Blink Pattern			
12	Load Field Fail	Attempted load of the field kernel or device tree failed.	<ol style="list-style-type: none"> 1. Thumb drive with .scfx file, power down, set address rotaries to 991, and power up. 2. Replace controller.
15	Load Recovery Fail	Attempted load of the recovery image failed.	Replace controller
18	Field Mount Fail	Failed to mount the field partition during a firmware update attempt.	<ol style="list-style-type: none"> 1. Thumb drive with .scfx file, power down, set address rotaries to 991, and power up. 2. Replace controller.
19	Bad Switch Setting	Rotary switches are set to a bad/unknown value.	Contact technical support.
21	Bad Firmware File	Unable to mount the firmware update file.	Download firmware file again and retry download.
22	Firmware Not Compatible	Firmware file downloaded is not compatible with this hardware.	Download the correct FW file for the controller.
24	Field Format Fail	Failed to reformat the field file system.	Replace controller.
25	Field Attach UBI Fail	Failed to attach (UBI) to the field file system.	Replace controller.
26	Field Mount Fail	Failed to mount the field file system.	Replace controller.
27	Bad Update Method	Don't know what our update method is.	Contact technical support.
31	No Firmware File Found	Unable to find a firmware update file.	Thumb drive has no .scfx file. .scfx file must be located at the root of the USB drive.
32	Multiple Firmware Found	Multiple firmware update files were found.	Too many .scfx files on the thumb drive. Can only have on .scfx file and must be located in the root of the USB drive.
34	Firmware Invalid		Download the firmware file again and retry download.
39	Firmware Invalid		Download the correct FW file again and retry download.
42	Bad Firmware File	Unable to mount the firmware update file.	Download the firmware file again and retry download.
44	Restore Failed	Database restore failed for some reason.	Try to restore using a different backup file (Restore file may be corrupt).
48	Hold	Crashed too many times and are now "holding."	Contact technical support.
49	Abnormal Termination	The embedded application terminated abnormally.	Contact technical support.

Table 5. Marquee LED status and error codes (continued)

LED Blink Pattern	Message	Description	Action by User
54	Firmware Not Compatible	The firmware file downloaded is not compatible with this hardware.	Download the correct FW file for the controller.
57	Kernel Update Failure	Failed to update the kernel.	<ol style="list-style-type: none"> 1. Try upgrading the controller firmware again 2. Replace controller.
59	Device Tree Failure	Failed to update the kernel device tree.	Not applicable for 210, 400-B, or 600.
62	Bootloader Failure	Failed to update the bootloader.	<ol style="list-style-type: none"> 1. Try upgrading the controller firmware again 2. Replace controller.
64	Recovery Failure	Failed to update the recovery file system.	<ol style="list-style-type: none"> 1. Try upgrading the controller firmware again 2. Replace controller.



Configuration and Maintenance

The Tracer® TU service tool is used to configure and maintain a Symbio™ 500 (refer to the following Tasks 1 through 9). Because the Symbio 500 is a self-serviceable unit, this device is not intended to be disassembled by the user for maintenance. This manual assumes the user has basic knowledge of using the Tracer TU service tool. Tracer TU operations, such as connecting to a controller directly using a USB cable or connecting indirectly using Tracer SC+ pass-through and starting a Tracer TU session are explained in the *Tracer® TU Service Tool User Guide* (BAS-SVU047*-EN). It is included on the Tracer TU installation CD. In addition, you can refer to the Tracer TU Connection Online Help.

Task 1; Load Application Code on a Blank Symbio 500

All Symbio 500 controllers ship without application code.

1. Start the Tracer TU service tool to establish a connection with the Symbio 500. If no firmware is present, the following message displays, *The Symbio 500 controller has no application code loaded. Please launch File Transfer wizard and load an appropriate configuration.*
2. Click **OK**. To load or upgrade the firmware, follow the procedure in the topic *Upgrading Controller Firmware* under the *Managing Configurations, Firmware, and Programs* in the Online Help.

Task 2; Choose a Symbio 500 Configuration Option

1. Become familiar with the parts of a Symbio 500 configuration. Refer to topic *The Main Parts of Device Setup and Configuration* in the *An Overview of Device Setup and Configuration* of the Tracer TU Online Help for Programmable Controllers.
2. Read *Point Configuration Overview* in the *Configuring and Managing Points* of the Online Help for an explanation of your configuration options. In addition, read the linked topics relevant to the approach you want to take.
3. You have two main configuration options:
 - Use the Tracer TU Configuration Screen to create a factory configuration.
Note: *You can make some modifications to Trane factory blower coil, fan coil, or unit ventilator configurations. Refer to the topic, An Overview of Editable Factory Configurations under the Configuring and Commission Equipment > Trane Factory Blower Coils, Fan Coils, and Unit Vents.*
 - Create or edit a custom (field programmed) configuration.

Tack 3; Specify Controller Settings

Complete the following tasks:

- Configure units of measure.
- Specify controller date and time.
- Specify the baud rate, if other than the default (76800).

For procedural information, refer to the topic, *Modifying Controller Settings* in the Online Help.

Task 4; Setup and Discover XM30, XM32, XM70, XM90 Expansion Modules

1. Mount, wire, address, and power the expansion module as described in the Installation Instructions that accompany the unit. Refer to the topic, *Setting Up And Discovering Expansion Modules* under the *Modifying Controller Settings* of the Online Help.
2. Set up the module(s) using the controls on the Expansion Modules box on the Controller Settings screen.
Note: *If adding an expansion module on the Controller Settings page, but the module is not connected to the controller, you will have to discover it on the Controller Status screen after it is connected and powered.*

Task 5; Specifying an Equipment Configuration

Go to the information sources supporting one of the following options that was chosen:

Option 1: Use the Tracer TU Configuration screen to create a factory configuration. Refer to the topics, *VAV Boxes, Trane Factory Blower Coils, Fan Coils, and Unit Vents, or Variable Speed Water Source Heat Pumps* in the Online Help.

Option 2: Create a Custom Configuration.

This option requires a thorough knowledge of the devices and the network you are installing, including an understanding of the TGP2 programs and the points they use.

1. Create points or open a previously created points file, make any edits, and save them to the Symbio 500.

Note: You can create, edit, and load points, either in Tracer TU, or in the TGP2 Editor. (See the *Configuring and Managing Points TOC book in the Tracer Graphical Programming (TGP2) Editor Help.*)

Be aware of the maximum point counts as shown in the following table.

Type	Number
Analog Input	500 software points (either online or offline)
Analog Output	500 software points (either online or offline)
Analog Value	500 software points (either online or offline)
Binary Input	500 software points (either online or offline)
Binary Output	500 software points (either online or offline)
Binary Value	500 software points (either online or offline)
Multistate Input	500 software points (either online or offline)
Multistate Output	500 software points (either online or offline)
Multistate Value	500 software points (either online or offline)

2. Specify setpoint values and equipment parameters on the Setpoints and Setup Parameters screens (Equipment Utility).

Note: You will supply the necessary TGP2 programs after you commission the hard-wired points. Refer to the following Task 7.

Task 6; Commissioning the Hard-wired Points

After you have all points configured, saved, and downloaded to the controller, you are ready to commission or test them by overriding Output and Value points. Refer to the topics under the *Overriding, Comparing, and Changing the Service Status of Points* of the Online Help.

Task 7; Modify and Create TGP2 Programs (As Needed)

Now that you have the hardware points in place and tested, you can create or edit TGP2 programs that will run the equipment according to the sequence of operations specified for your job. (See the topics under the “Developing and Managing TGP2 Programs” TOC book in the Tracer Graphical Programming (TGP2) Editor Help for programming procedures. Also see the “TGP2 Block Reference” TOC book to learn how the various blocks work and for information about their properties. For more information about TGP2 programming instruction, refer to the Tracer Graphical Programming (TGP2) Applications Guide, BAS-APG008-EN.

Task 8; Monitoring/Viewing Point, Alarm, and Controller Status

Refer to the topics under *Viewing the Status of Points and Alarms* in the Online Help.

Task 9; Backing Up/Restoring Files and Configurations

Upload, back up, replace, or update configuration files, controller firmware, and TGP2 programs using the File Transfer Utility and the Backup Utility. Refer to the topics under *Managing Configurations, Firmware, and Files* in the Online Help.



Maintenance

Symbio controllers have no user-serviceable components. The controllers do not contain batteries or removable memory storage disks. No maintenance is required.

If replacement is necessary, the best practice is to use Tracer TU to restore a user-created backup file.

Commissioning and Troubleshooting in Powered State

This section provides illustrations and methods about how to check the Symbio 500 points after making connection and applying power (indicated in each illustration by the terminal connector and Symbio 500 label). The step numbers or method numbers in each illustration correspond to the information in each table.

To test inputs/outputs requires a digital multimeter and a small flat-tip screwdriver.

Note: The Out of Service and Override features in Tracer TU can be used to simulate operation for testing the input/output interaction. By placing a point out of service or overriding at the priority required for control, the user can enter a value for the point sufficient to trigger a reaction at the output based on the TGP2 logic controlling the output.

Voltage Inputs

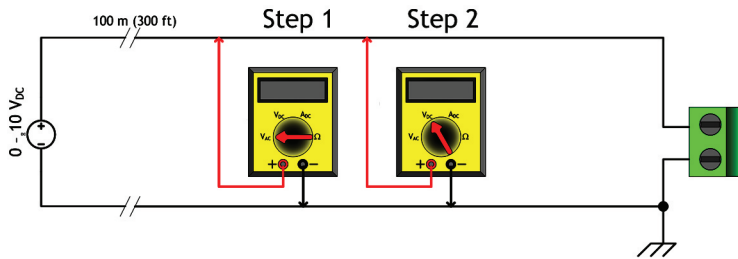

Checkout Procedure	Measurement	Expected Value
Step 1	Measure AC voltage across the voltage termination	Vac ≈ 0.0 V AC voltage will affect further measurement
Step 2	Measure DC voltage across the voltage termination	Compare to input status in Tracer TU

Resistive Inputs

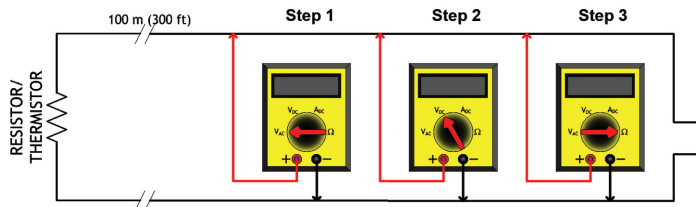

Checkout Procedure	Measurement	Expected Value
Step 1	Measure AC voltage across the resistive termination	Vac ≈ 0.0 V AC voltage will affect further measurement
Step 2	Measure DC voltage across the resistive termination	See the charts below

Commissioning and Troubleshooting in Powered State

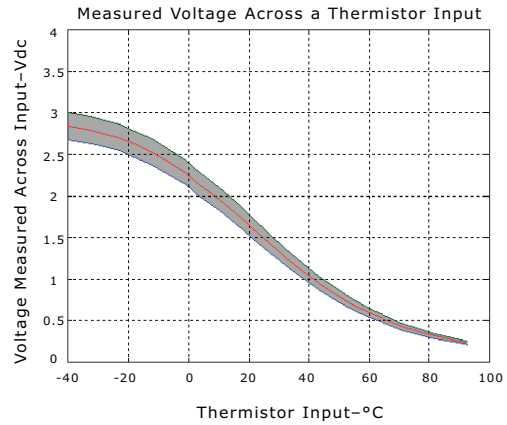
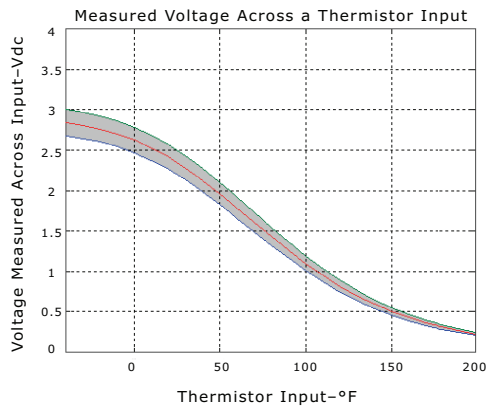

Charts showing measurements across thermistor input (Fahr/Celsius) and resistive input.

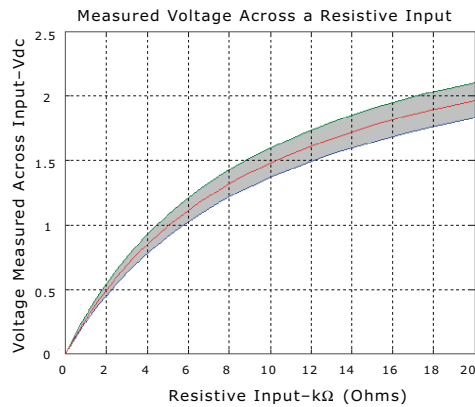

Current Inputs, Methods 1 or 2

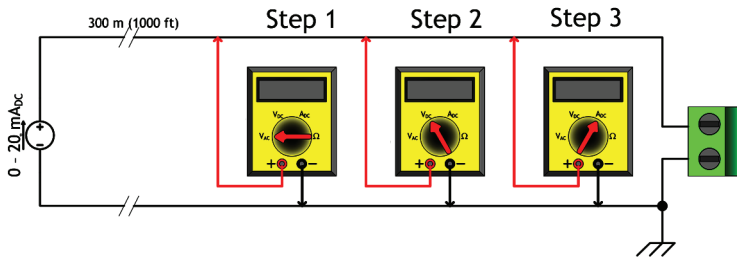

General Information	Checkout Procedure	Measurement	Expected Value
Method 1 takes advantage of the very low input resistance of a DMM in current measurement mode. However, this method affects the value of the Symbio 500 will use while controlling outputs. When the meter is set to current mode, the current flowing into the Symbio 500 circuit will drop to zero or near zero.	Step 1	Measure AC voltage across the current input	Vac ≈ 0.0 V AC voltage will affect further measurement
	Step 2	Measure DC voltage across the current input	Vdc ≈ 0.0 V
	Step 3	Measure DC current across the current input	Compare to input status in Tracer TU

Commissioning and Troubleshooting in Powered State

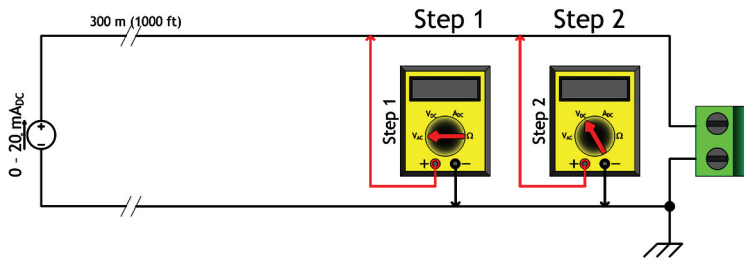

General Information	Checkout Procedure	Measurement	Expected Value
Method 2 interferes less in regards to the system. In voltage mode, the DMM affects the circuit less. Additional information is needed to translate the voltage measured to current flowing through the circuit.	Step 1	Measure AC voltage across the voltage input	Vac ≈ 0.0 V AC voltage will affect further measurement
	Step 2	Measure DC voltage across the voltage termination	See the chart below

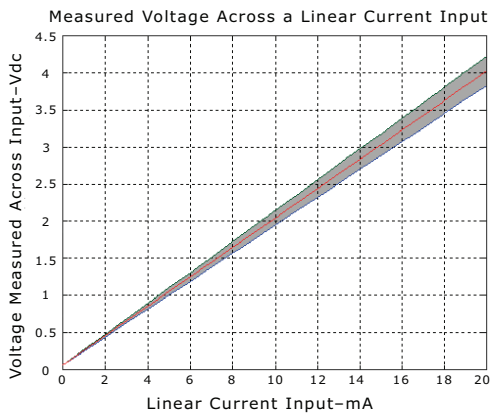

24 Vac Measurement

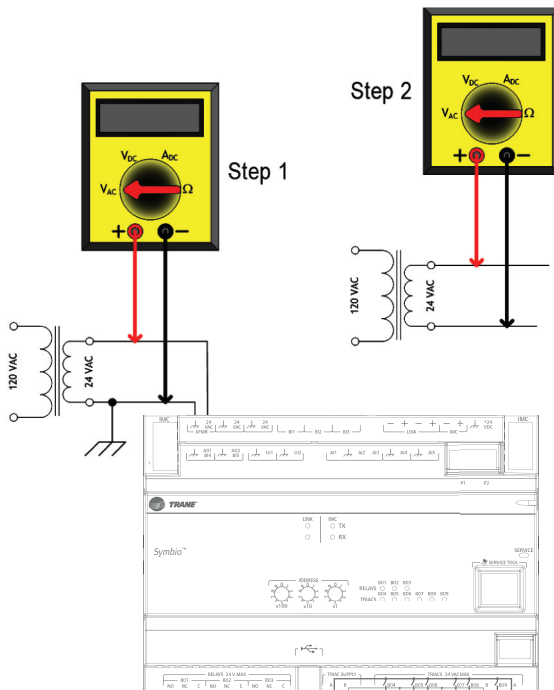

Commissioning and Troubleshooting in Powered State

General Information	Checkout Procedure	Measurement	Expected Value
<p>Checking the voltage that is powering the Symbio 500 is often a necessary step when commissioning or troubleshooting. Operational issues and LED operation may result in a need to measure the input power. When troubleshooting, it is faster to take measurements while the load is in place. If Step 1 indicates an out-of-specification voltage, disconnect the Symbio 500 and measure the AC voltage across the transformer. These measurements can direct the technician towards the problem source.</p>	Step 1	Measure AC voltage with the Symbio 500 connected. Perform this measurement while the unit is under load.	$20.0 \text{ Vac} \leq \text{Vac} \leq 30.0 \text{ Vac}$
	Step 2	Measure AC voltage with the Symbio 500 unconnected. Perform this measurement while the unit is not under load.	$20.0 \text{ Vac} \leq \text{Vac} \leq 30.0 \text{ Vac}$

Binary Inputs, 24 Vac Detect, Method 1 or 2

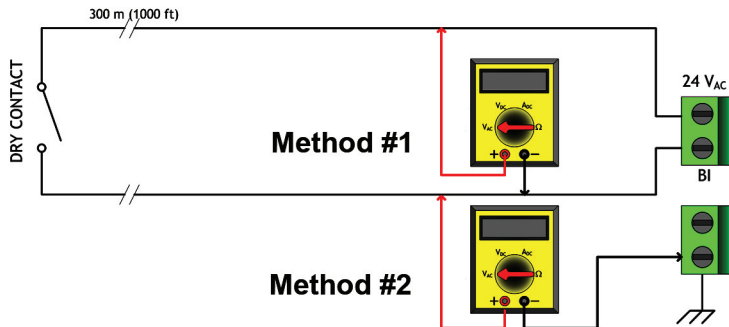

General Information and Checkout Procedure	Measurement	Expected Value
Method 1: Voltage across binary input measured without reference to chassis ground.	Measure AC voltage across the binary input	$\text{Vac} \approx 24.0 \text{ V}$ (state = OFF) $\text{Vac} \approx 0.0 \text{ V}$ (state = ON)
Method 2: Voltage across binary input measured with reference to chassis ground. Any connection with chassis ground symbol can serve as a ground reference for this method.	Measure DC voltage across the binary input	$\text{Vac} \approx 0.0 \text{ V}$ (state = ON) $\text{Vac} \approx 24.0 \text{ V}$ (state = OFF)

Binary Inputs, Based on Analog Output Connection

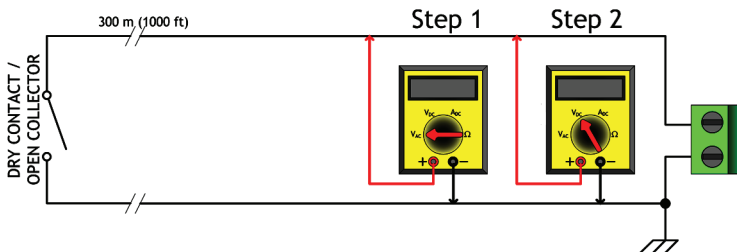

General Information	Checkout Procedure	Measurement	Expected Value
<p>The Symbio 500 analog output connections can be configured as binary inputs. This can be used only with dry contact or open collector-type sensors.</p>	Step 1	Measure AC voltage across the binary input	$\text{Vac} \approx 0.0 \text{ V}$ AC voltage will affect further measurement
	Step 2	Measure DC voltage across the binary input	$\text{Vdc} \leq 2.0 \text{ V}$ (state = ON) $\text{Vfc} \leq 2.0 \text{ V}$ (state = OFF)

Open-collector Based Binary Sensors

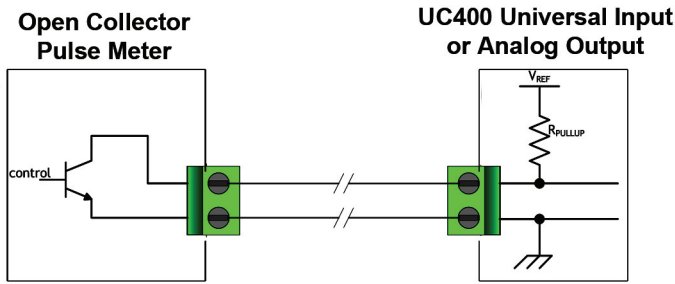

Measurement Procedure	Expected Value
Measure DC voltage across the binary input	$V_{dc} \leq 0.2 \text{ V}$ (BJT = ON) UI: $V_{dc} \approx 3.3 \text{ V}$ (BJT = OFF) AO: $V_{dc} \approx 22.0 \text{ V}$ (BJT = ON)

Open-collector based binary sensors use a bipolar junction transistor (BJT; a three-terminal device in which emitter-to-collector current is controlled by base current) as the switching device in place of a relay. The term, open collector, refers to the collector connection on the transistor itself. Open-collector circuits are used for their low fatigue rate and quick response relative to relay-based outputs. The circuit within the pulse meter is completed when adding a pull-up resistance and reference voltage. On the Symbio 500, both universal input (UI) and analog output (AO) circuits add the necessary resistance and voltage without external parts.

Note: The reference voltage must always be DC.

The voltage across the pulse meter terminals will bounce between V_{sat} (saturation voltage) of the transistor in the pulse meter and the V_{ref} (reference voltage) provided by the UI or AO circuits of the Symbio 500. Most bipolar transistors have a V_{sat} of less than 0.2 Vdc.

The DMM sampling rate may be too slow to measure pulse meter output transitions.

Note: Check the specifications of the DMM being used. It may be necessary to use an oscilloscope to measure the transition voltages.

Voltage Analog Output

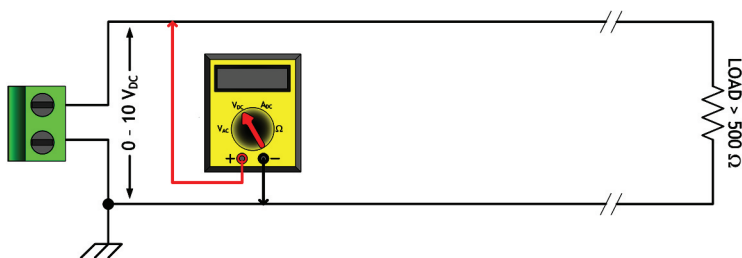

Measurement Procedure	Expected Value
Measure DC voltage across the voltage termination	Compare to the expected value based on request from controller. This request may be based on an override of the output value.

Current Analog Output, Methods 1 or 2

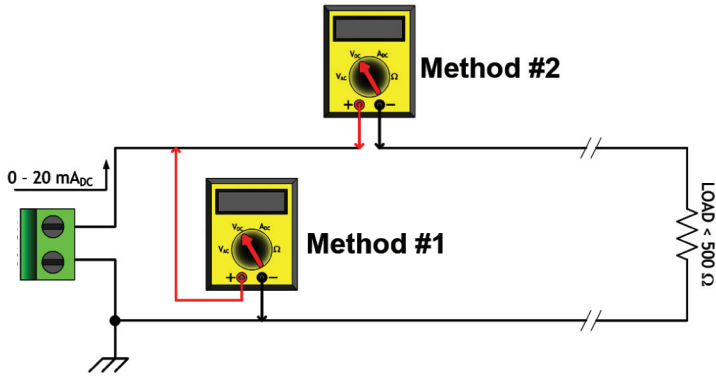

General Information and Checkout Procedure	Measurement	Expected Value
Method 1: Shorting the current output- this method leaves the circuit intact, however, it will cause the vast majority of the current to flow through the meter instead of the load (NOTE LOAD RESISTANCE).	Measure DC current across the current termination	Compare expected value based on request from controller. This request may be based on an override of the output value.
Method 2: Measuring current directly- this method is most the typical way to measure current and has the advantage of leaving the load in the loop. However, the circuit must be broken when using this method.	Measure DC current in series with the current termination	Compare expected value based on request from controller. This request may be based on an override of the output value.

Binary Output, TRIAC High Side Switching, Methods 1 or 2

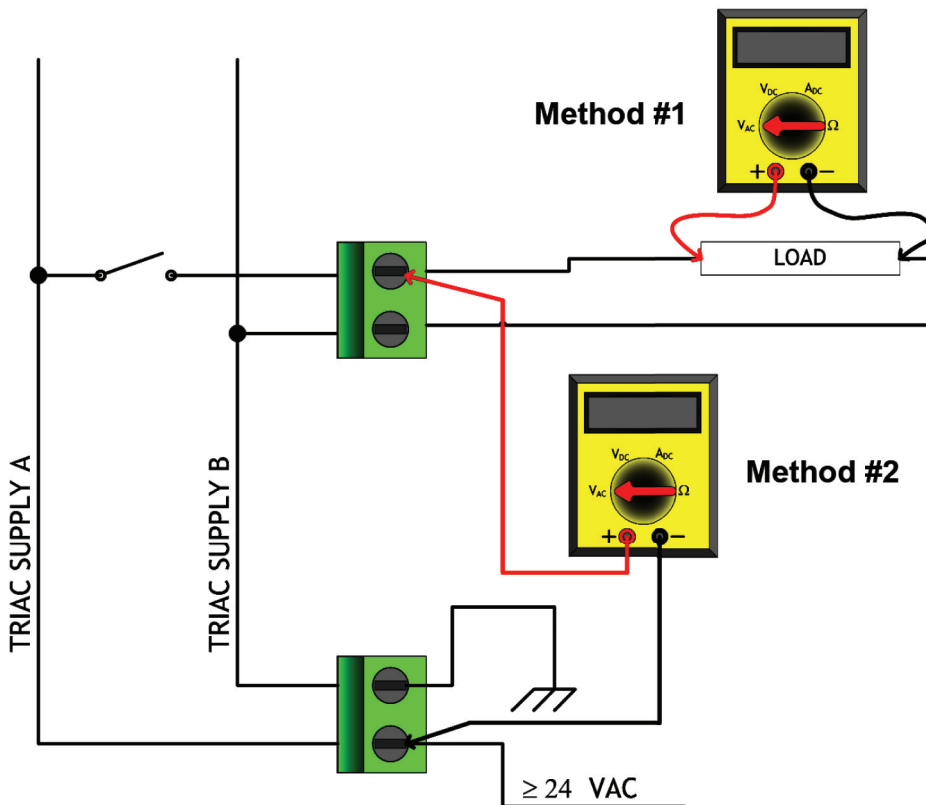

Commissioning and Troubleshooting in Powered State

Checkout Procedure	Measurement	Expected Value
Method 1	Measure AC voltage across the binary output	$V_{ac} \approx 0.0 \text{ V}$ (TRIAC = OFF) $V_{ac} \geq 24.0 \text{ V}$ (TRIAC = ON)
Method 2	Measure AC voltage across the binary input	$V_{ac} \approx 0.0 \text{ V}$ (TRIAC = ON) $V_{ac} \geq 24.0 \text{ V}$ (TRIAC = OFF)

Binary Output, TRIAC Low Side Switching, Methods 1 or 2

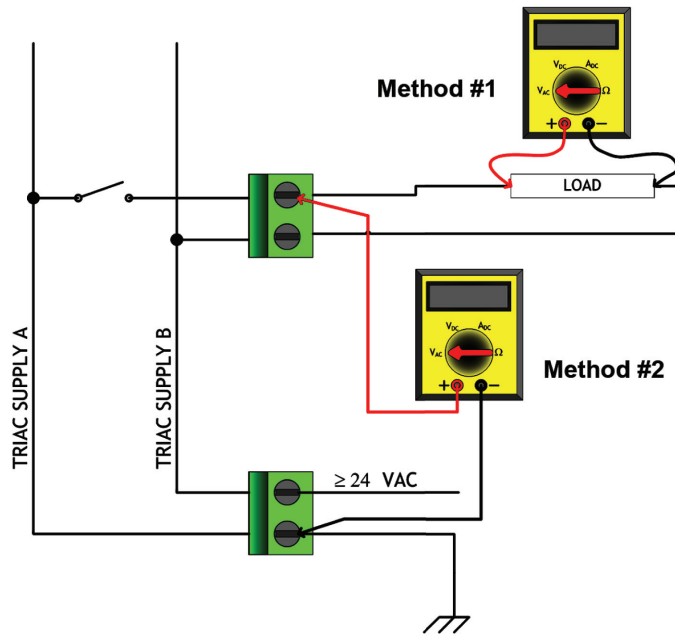

Checkout Procedure	Measurement	Expected Value
Method 1	Measure AC voltage across the binary output	$V_{ac} \approx 0.0 \text{ V}$ (TRIAC = OFF) $V_{ac} \geq 24.0 \text{ V}$ (TRIAC = ON)
Method 2	Measure AC voltage across the binary input	$V_{ac} \approx 0.0 \text{ V}$ (TRIAC = ON) $V_{ac} \geq 24.0 \text{ V}$ (TRIAC = OFF)

Ground Measurements

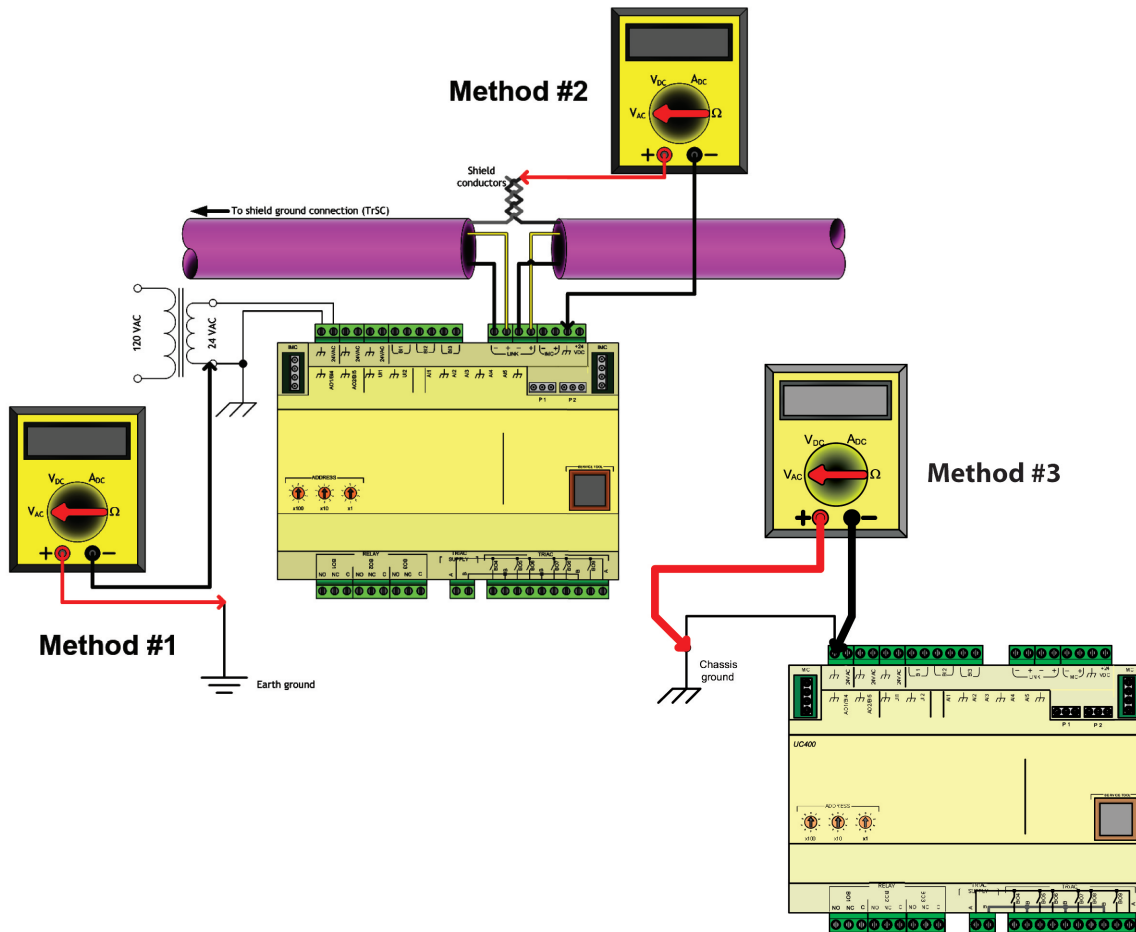

General Information and Checkout Procedure	Measurement	Expected Value
Method 1: AC voltage between shield conductors and device chassis ground- the voltage difference between BACnet MS/TP device chassis ground connections should be close to zero. If the voltage difference is greater that 4.0 Vac, there will be marginal communication or intermittent communication problems. If the voltage difference is greater that 7.0 Vac, some devices will no longer communicate.	Measure AC voltage across the voltage termination and confirm that only one end of the shield conductor is tied to the earth ground	Vac ≤ 2.0 V
Method 2: AC voltage between earth ground and device chassis ground- the chassis ground of the Symbio 500 needs to be connected to earth ground by some route. Do not assume that the building frame is a valid earth ground.	Measure AC voltage across the voltage termination and confirm that only one end of the shield conductor is tied to the earth ground	Vac ≤ 4.0 V (Must comply with National Electrical Code™ and local electrical codes)
Method 3: AC voltage between case (nominal chassis ground) and device chassis ground connector- in this illustration the connection appears as a short. However, it is possible that the chassis ground connection on the controller may actually be connected to the equipment metal some distance away. Use this measurement method if there are communication issues or input stability problems.	Measure AC voltage across the voltage termination. For this measurement, confirm that only one end of the shield conductor is tied to the earth ground.	Vac ≤ 4.0 V (Must comply with National Electrical Code™ and local electrical codes) Typically, this should be Vac ≤ 1.0 V



Resources

- *Air-Fi® Wireless System Installation, Operation, and Maintenance (BAS-SVX40*-EN)*
- *Air-Fi® Network Design Installation, Operation, and Maintenance (BAS-SVX55*-EN)*
- *Air Systems Tracer® SC+ System Controller with the Tracer® Synchrony User Interface Application Guide (BAS-APG036*-EN)*
- *BACnet® MS-TP Wiring and Link Performance Best Practices and Troubleshooting Guide (BAS-SVX51*-EN)*
- *Tracer Graphical Programming 2 (TGP2) Editor Online Help*
- *Tracer Graphical Programming (TGP2) Application Guide (BAS-APG008*-EN)*
- *Tracer TU Online Help*
- *Tracer® TU Service Tool User Guide (BAS-SVU046*-EN)*
- *VariTrane™ Fan-Powered VP*F, LP*F Product Catalog (VAV-PRC012*-EN)*
- *Tracer XM30, XM32, XM70, and XM90 Expansion Modules Installation, Operation, and Maintenance Guide (BAS-SVX46*-EN)*
- *BACnet®/IP Wiring and Best Practices Application Guide (BAS-APG046*-EN)*

Trane - by Trane Technologies (NYSE: TT), a global innovator - creates comfortable, energy efficient indoor environments for commercial and residential applications. For more information, please visit trane.com or tranetechnologies.com.

Trane has a policy of continuous product and product data improvements and reserves the right to change design and specifications without notice. We are committed to using environmentally conscious print practices.

BAS-SVX090C-EN 30 Jun 2026
Supersedes BAS-SVX090B-EN (April 2023)

©2026 Trane