



# Installation, Operation, and Maintenance

## E50 Series

### Compact Power and Energy Meter

BACnet TP E50H2-T2  
PN: X13690276002



#### ⚠ SAFETY WARNING

Only qualified personnel should install and service the equipment. The installation, starting up, and servicing of heating, ventilating, and air-conditioning equipment can be hazardous and requires specific knowledge and training. Improperly installed, adjusted or altered equipment by an unqualified person could result in death or serious injury. When working on the equipment, observe all precautions in the literature and on the tags, stickers, and labels that are attached to the equipment.



# Introduction

The E50H2-T2 DIN rail power meter provides a solution for measuring energy data with a single device. Inputs include control power, CT, and 3-phase voltage. The E50H2-T2 supports BACnet TP protocol. The E50H2-T2 has one pulse contact input and a phase loss alarm output. The LCD screen on the faceplate allows instant output viewing.

The meter is housed in a plastic enclosure suitable for installation on T35 DIN rail according to EN50022. It can be mounted with any orientation over the entire ambient temperature range, either on a DIN rail or in a panel. The E50H2-T2 meters are not sensitive to CT orientation, reducing installation errors.

## Copyright

This document and the information in it are the property of Trane, and may not be used or reproduced in whole or in part without written permission. Trane reserves the right to revise this publication at any time, and to make changes to its content without obligation to notify any person of such revision or change.

## Trademarks

All trademarks referenced in this document are the trademarks of their respective owners.

## Warnings, Cautions, and Notices

Safety advisories appear throughout this manual as required. Your personal safety and the proper operation of this machine depend upon the strict observance of these precautions.

---

The three types of advisories are defined as follows:



Indicates a potentially hazardous situation which, if not avoided, could result in death or serious injury.



Indicates a potentially hazardous situation which, if not avoided, could result in minor or moderate injury. It could also be used to alert against unsafe practices.



Indicates a situation that could result in equipment or property-damage only accidents.

---

## Important Environmental Concerns

Scientific research has shown that certain man-made chemicals can affect the earth's naturally occurring stratospheric ozone layer when released to the atmosphere. In particular, several of the identified chemicals that may affect the ozone layer are refrigerants that contain Chlorine, Fluorine and Carbon (CFCs) and those containing Hydrogen, Chlorine, Fluorine and Carbon (HCFCs). Not all refrigerants containing these compounds have the same potential impact to the environment. Trane advocates the responsible handling of all refrigerants-including industry replacements for CFCs and HCFCs such as saturated or unsaturated HFCs and HCFCs.

## Important Responsible Refrigerant Practices

Trane believes that responsible refrigerant practices are important to the environment, our customers, and the air conditioning industry. All technicians who handle refrigerants must be certified according to local rules. For the USA, the Federal Clean Air Act (Section 608) sets forth the requirements for handling, reclaiming, recovering and recycling of certain refrigerants and the equipment that is used in these service procedures. In addition, some states or municipalities may have additional requirements that must also be adhered to for responsible management of refrigerants. Know the applicable laws and follow them.

**⚠ WARNING****Proper Field Wiring and Grounding Required!**

Failure to follow code could result in death or serious injury.

All field wiring **MUST** be performed by qualified personnel. Improperly installed and grounded field wiring poses **FIRE** and **ELECTROCUTION** hazards. To avoid these hazards, you **MUST** follow requirements for field wiring installation and grounding as described in NEC and your local/state/national electrical codes.

**⚠ WARNING****Personal Protective Equipment (PPE) Required!**

Failure to wear proper PPE for the job being undertaken could result in death or serious injury.

Technicians, in order to protect themselves from potential electrical, mechanical, and chemical hazards, **MUST** follow precautions in this manual and on the tags, stickers, and labels, as well as the instructions below:

- Before installing/servicing this unit, technicians **MUST** put on all PPE required for the work being undertaken (Examples; cut resistant gloves/sleeves, butyl gloves, safety glasses, hard hat/bump cap, fall protection, electrical PPE and arc flash clothing). **ALWAYS** refer to appropriate Safety Data Sheets (SDS) and OSHA guidelines for proper PPE.
- When working with or around hazardous chemicals, **ALWAYS** refer to the appropriate SDS and OSHA/GHS (Global Harmonized System of Classification and Labelling of Chemicals) guidelines for information on allowable personal exposure levels, proper respiratory protection and handling instructions.
- If there is a risk of energized electrical contact, arc, or flash, technicians **MUST** put on all PPE in accordance with OSHA, NFPA 70E, or other country-specific requirements for arc flash protection, **PRIOR** to servicing the unit. **NEVER PERFORM ANY SWITCHING, DISCONNECTING, OR VOLTAGE TESTING WITHOUT PROPER ELECTRICAL PPE AND ARC FLASH CLOTHING. ENSURE ELECTRICAL METERS AND EQUIPMENT ARE PROPERLY RATED FOR INTENDED VOLTAGE.**

**⚠ WARNING****Follow EHS Policies!**

Failure to follow instructions below could result in death or serious injury.

- All Trane personnel must follow the company's Environmental, Health and Safety (EHS) policies when performing work such as hot work, electrical, fall protection, lockout/tagout, refrigerant handling, etc. Where local regulations are more stringent than these policies, those regulations supersede these policies.
- Non-Trane personnel should always follow local regulations.



# Table of Contents

- Product Identification, Specifications, and Data Outputs ..... 5
  - Unit Dimensions ..... 7
  - Product Diagram and Screen Display ..... 8
- Installation ..... 9
- Supported Systems ..... 11
- Wiring ..... 12
  - Wiring Symbolism ..... 12
  - Wiring Diagrams ..... 14
    - Fuse Recommendations ..... 15
- Navigating Screens and Setting Parameters ..... 16
- Pulse Contact Input ..... 17
- User Interface ..... 18
- RS-485 Communications ..... 23
- Standard BACnet Default Settings ..... 24
- BACnet Programming ..... 25
  - BACnet Programming Overview ..... 25
  - BACnet Programming Objects ..... 26
    - Device Object ..... 27
    - Analog Value (AV) Objects ..... 27
    - Analog Input (AI) Objects ..... 28
    - Binary Input (BI) Objects ..... 31
- Troubleshooting ..... 32
- China RoHS Compliance ..... 33
- Additional Resources ..... 34



# Product Identification, Specifications, and Data Outputs

Product Identification	
Model:	E50H2-T2
Description:	BACnet TP Protocol Output
Output:	Alarm Output, Full Data Set, Pulse Input
Measurement Accuracy	
Real Power and Energy:	IEC 62053-22 Class 0.2S, ANSI C12.20 0.2%
Reactive Power and Energy:	IEC 62053-23 Class 2, 2%
Current:	0.4% (+0.015% per °C deviation from 25°C) from 5% to 100% of range; 0.8% (+0.015% per °C deviation from 25°C) from 1% to 5% of range
Voltage:	0.4% (+0.015% per °C deviation from 25°C) from 90 V <sub>L-N</sub> to 600 V <sub>AC-L</sub>
Sample Rate:	2520 samples per second
Data Update Rate:	1 sec
Type of Measurement:	True RMS up to the 21st harmonic 60 Hz; One to three phase AC system
Input Voltage Characteristics:	
Measured AC Voltage:	<ul style="list-style-type: none"> <li>Minimum 90 V<sub>L-N</sub> (156 V<sub>L-L</sub>) for stated accuracy</li> <li>U.L. Maximum: 600 V<sub>L-L</sub> (347 V<sub>L-N</sub>)</li> <li>CE Maximum: 300V<sub>L-N</sub></li> </ul>
Metering Over Range:	+20%
Impedance:	2.5M Ω <sub>L-N</sub> /5M Ω <sub>L-L</sub>
Frequency Range:	45 Hz to 65 Hz
Input Current Characteristics	
CT Scaling:	Primary: Adjustable from 5 A to 32,000 A
Measurement Input Range:	0 to 0.333 Vac or 0 to 1.0 Vac (+20% over-range), rated for use with Class 1 voltage inputs
Impedance:	10.6 kΩ (1/3 V mode) or 32.1 kΩ (1 V mode)
Control Power	
AC:	<ul style="list-style-type: none"> <li>5 VA max.; 90 V min.</li> <li>UL Maximum: 600 V<sub>L-L</sub> (347 V<sub>L-N</sub>)</li> <li>CE Maximum: 300V<sub>L-N</sub></li> </ul>
DC: <i>External DC current limiting is required.</i>	<ul style="list-style-type: none"> <li>3 W maximum</li> <li>U.L and CE: 125 Vdc to 300 Vdc</li> </ul>
Ride-through Time:	100 milliseconds at 120 Vac
Input	
Pulse:	Solid-state or mechanical contacts (current less than 1 mA), 1 pulse input.
Minimum Pulse Width:	20 milliseconds
Output	
Alarm Contacts:	N.C., static output (30 Vac/DC, 100 mA maximum @ 25°C, derate 0.56 mA per °C above 25°C)



## Product Identification, Specifications, and Data Outputs

RS-485 Port:	2 wire, 9600 to 115.2 kbaud, BACnet TP
<b>Mechanical Characteristics:</b>	
Weight:	0.62 LB. (0.28 kg)
IP40 Degree of Protection (IEC60529):	IP40 front display; IP20 Meter
Display Characteristics:	Backlit blue LCD
Terminal Block Screw Torque:	0.37 ft-lb (0.5 N·m) nominal/0.44 ft-lb (0.6 N·m) maximum
Terminal Block Wire Size:	24 AWG to 14 AWG (0.2 to 2.1 mm <sup>2</sup> )
Rail:	T35 (35 mm) DIN Rail per EN50022
<b>Operating Conditions:</b>	
Operating Temp:	-30°C to 70°C (-22°F to 158°F)
Storage Temp:	-40° to 85°C (-40° to 185°F)
Humidity Range:	<95% RH (non-condensing)
Altitude of Operation:	3000 m
<b>Agency Compliance</b>	
U.S. and Canada:	<ul style="list-style-type: none"> <li>CAT III;</li> <li>Pollution Degree 2</li> <li>For distribution systems up to 347 V<sub>L-N</sub>/600 VaC<sub>L-L</sub></li> </ul>
CE:	<ul style="list-style-type: none"> <li>CAT III;</li> <li>Pollution Degree 2</li> <li>For distribution systems up to 300 V<sub>L-N</sub></li> </ul>
Dielectric Withstand:	Per U.L. 508, EN61010
Conducted/Radiated Emissions:	FCC part 15 Class B, EN55011/EN61000 Class B (residential and light industrial)
Conducted/Radiated Immunity:	U.L. EN61000 Class A (heavy industrial)
U.S./Canada (cULus)	U.L. 508 (open type device)/CSA 22.2 No. 14-05
Europe (CE):	U.L. EN61010-1
<b>Data Outputs (Only BACnet TP)</b>	
Full Data Set:	<ul style="list-style-type: none"> <li>Power (kW), Energy (kWh)</li> <li>Configurable for CT &amp; PT ratios, system type, and passwords</li> <li>Diagnostic alerts</li> <li>Current/Volts are both 3-phase average</li> <li>Volts by phase Line-Line and Line-Neutral</li> <li>Power: real, reactive, and apparent 3-phase total and per phase</li> <li>Power factor: 3-phase average and per phase</li> <li>Frequency</li> <li>Power demand: most recent and peak</li> <li>Demand configuration: fixed, rolling block, and external sync</li> <li>Real time clock uses BACnet time synchronization services</li> </ul>

# Unit Dimensions

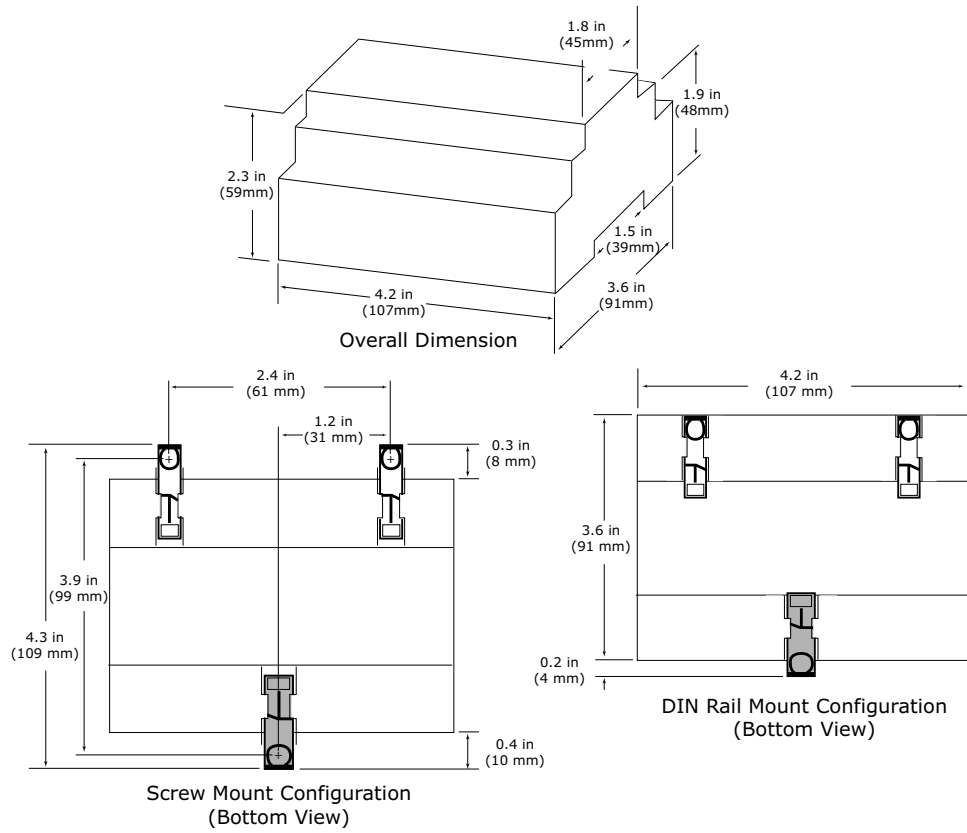

## Product Diagram and Screen Display

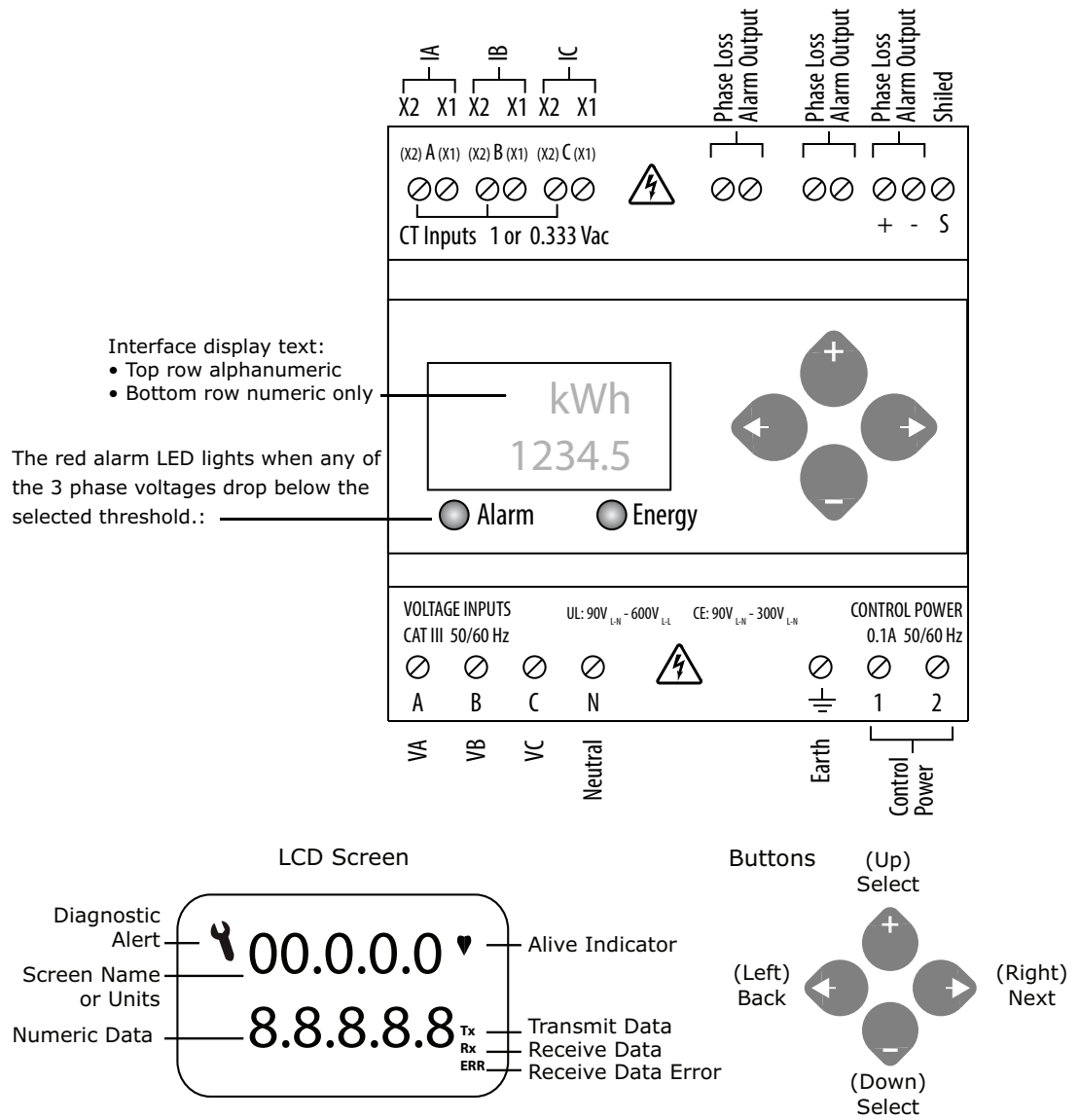





# Installation

Read the following guidelines before starting installation.

- Disconnect power prior to installation.
- Reinstall any covers displaced during installation before re-powering unit.
- Mount the meter in an appropriate electrical enclosure near equipment to be monitored.
- Do not install the load side of a variable frequency drive (VFD).

Mount the meter using one of the following two methods:

## 1. DIN Rail Mount

- a. Attach mounting clips to the underside of housing by sliding them into the slots from the inside.

**Note:** *The stopping pegs must face the housing and the outside edge of the clip must be flush with the outside edge of the housing.*

- b. Snap the clips onto the DIN rail.

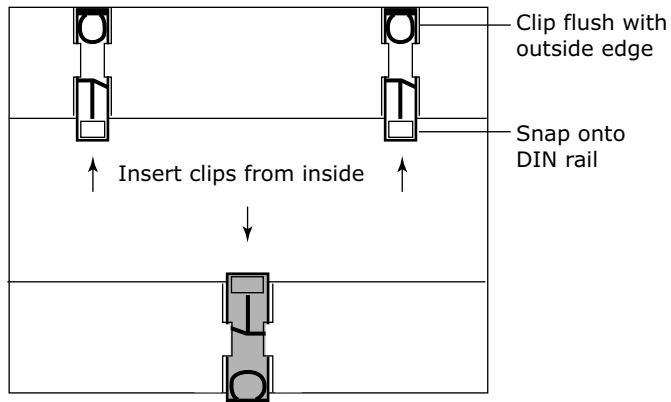

## 2. Screw Mount

- a. Attach mounting clips to the underside of housing by sliding them into the slots from the inside.

**Note:** *The stopping pegs must face the housing and the outside edge of the clip must be flush with the outside edge of the housing.*

- b. Use three (3) #8 screws (not supplied) to mount the meter to the inside of the enclosure.

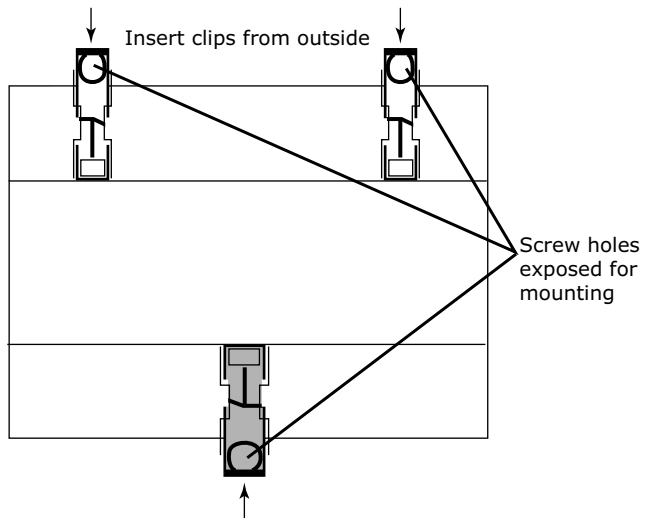
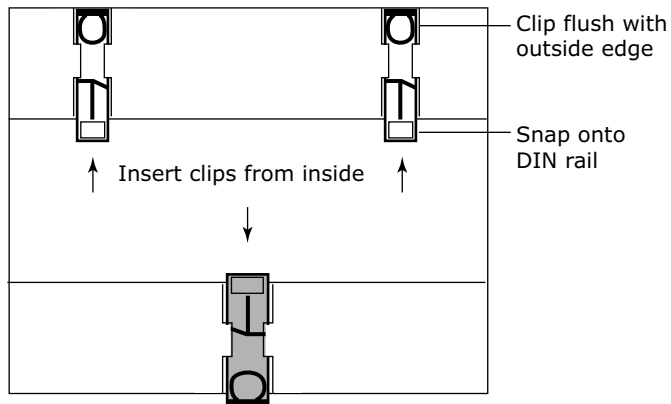



# Supported Systems

The E50H2-T2 meter has a number of different possible system wiring configurations (Refer to the table below and next section, Wiring Diagrams). To configure the meter, set the System Type via the User Interface or by writing the Present\_Value of AV2 with the system type value listed in the following table. The system type tells the meter which of its current and voltage inputs are valid, which are to be ignored, and if neutral is connected. Setting the correct system type prevents unwanted energy accumulation on unused inputs, selects the formula to calculate the Theoretical Maximum System Power, and determines which phase loss algorithm is to be used. The phase loss algorithm is configured as a percent of the Line-to-Line System Voltage (except when in System Type 10). In addition, it calculates the expected Line-to-Neutral voltages for system types that have Neutral (12 & 40). Values that are not valid in a particular System Type display as — on the User Interface or as **QNAN** in the BACnet objects.





**Note:** To avoid distortion, use parallel wires for control power and voltage inputs.

# Wires	CTs		Voltage Connections			System Type		Phase Loss Measurement			Wiring Dia-gram
	Qty	ID	Qty	ID	Type	BACnet Object AV2	User Interface (SET-UP>S SYS)	VLL	VLN	Bal-ance	Wiring #
Single-Phase Wiring											
2	1	A	2	A, N	L-N	10	1L+1n		AN		1
2	1	A	2	A, B	L-L	11	2L	AB			2
3	2	A,B	3	A, B, N	L-L w/ N	12	2L+1n	AB	AN, AB	AN-AB	3
Three-Phase Wiring											
3	3	A, B, C	3	A, B, C	Delta	31	3L	AB, BC, CA		AB-BC-CA	4
4	3	A, B, C	4	A, B, C, N	Grounded Wye	40	3L-1n	AB, BC, CA	AN, BN, CN	AN-BN-CN and AB-BC-CA	5,6

# Wiring

## Wiring Symbolism

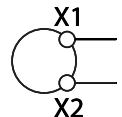
Refer to the following symbols used in the wiring diagrams.

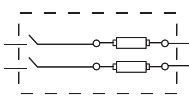
	Voltage Disconnect Switch
	Fuse <b>Note:</b> <i>Installer is responsible for ensuring compliance with local requirements.</i>
	Earth Ground
	Current Transducer
	Potential Transformer
	Protection containing a voltage disconnect switch with a fuse or disconnect circuit breaker. The protection device must be rated for the available short circuit current at the connection point.

### NOTICE

#### Equipment Damage!

Failure to follow instructions below could result in overheating and permanent equipment damage.

This product is designed only for use with 1 Volt or 0.333 Volt current transducers. Do not use current output CTs on this product.

### ⚠ WARNING

#### Hazardous Voltage!

Failure to disconnect power before servicing could result in death or serious injury. Disconnect all electric power, including remote disconnects before servicing. Follow proper lockout/tagout procedures to ensure the power can not be inadvertently energized. Verify that no power is present with a voltmeter.

### ⚠ WARNING

#### Hazardous Voltage and Equipment Damage!

Failure to follow instructions below could result in death or serious injury. CT terminals are referenced to neutral on the meter and may be at elevated voltages. Do not contact meter terminals while the unit is connected. Do not connect or short other circuits to the CT terminals.

Disconnect all electric power, including remote disconnects before servicing. Follow proper lockout/tagout procedures to ensure the power can not be inadvertently energized. Verify that no power is present with a CAT III or IV voltmeter rated per NFPA 70E.

**⚠ WARNING****Electrical Shock, Explosion, or Arc Flash Hazard!**

Failure to follow these instructions could result in death or serious injury.

Install the product in an appropriate electrical/fire enclosure per local regulations. Do not install the product in hazardous or classified locations.

Do not use the product for life or safety applications.

Do not exceed the product ratings or maximum limits. Products rated only for basic insulation must be installed on insulated conductors.

Current transformer secondaries (current mode) must be shorted or connected to a burden at all times.

Remove all wire scraps, tools, replace all doors, covers and protective devices before powering the equipment.

# Wiring Diagrams

Figure 1. 1-Phase and 3-Phase Diagrams

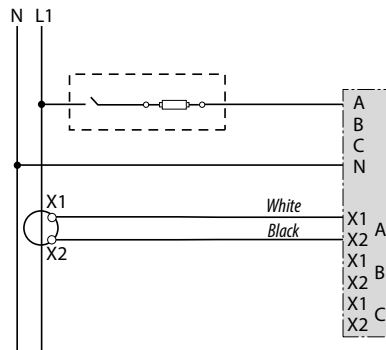

#1: 1-Phase, Line-to-Neutral, 2-Wire System, 1 CT  
Use System Type 10 (1L+1n)

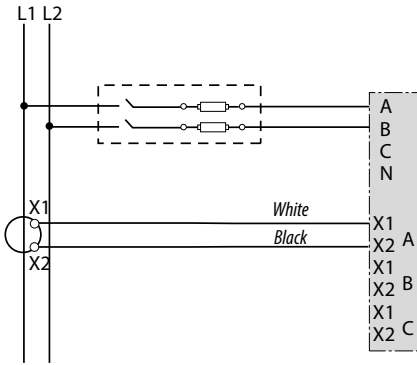

#2: 1-Phase, Line-to-Line, 2-Wire System, 1 CT  
Use System Type 11 (2L)

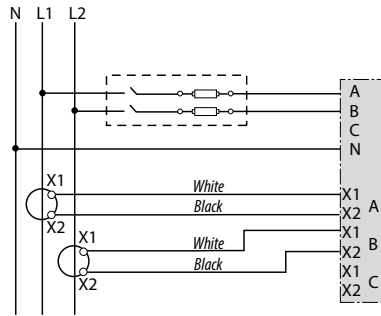

#3: 1-Phase, Direct Voltage Connection, 2 CT  
Use System Type 12 (2L+1n)

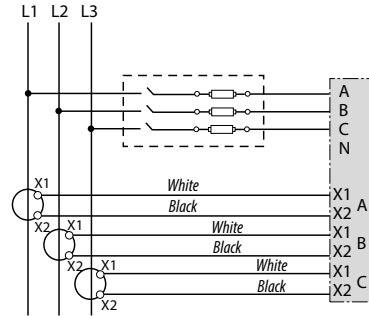

#4: 3-Phase, 3-Wire System, 3 CT, No PT  
Use System Type 31 (3L)

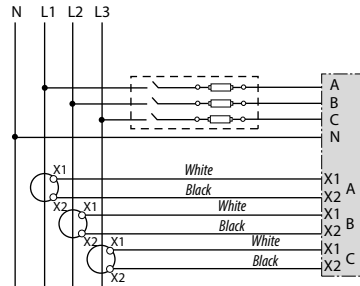

#5: 3-Phase, 4-Wire, Direct Voltage Input Connection, 3 CT  
Use System Type 40 (3L+1n)

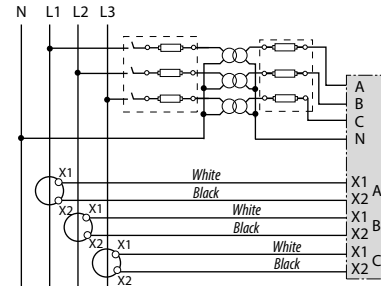

#6: 3-Phase, 4-Wire Wye Connection, 3 CT, 3 PT  
Use System Type 40 (3L+1n)

**Figure 2. Control Power Diagrams**

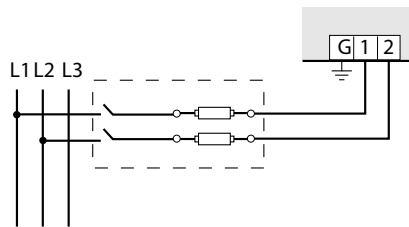

#1: Direct Connect Control Power, Line-to-Line  
Line-to-Line from 90 Vac to 600 Vac (UL). In UL installations the lines may be floating (such as a delta). If any lines are tied to an earth (such as a corner grounded delta), refer to the Line-to-Neutral installation limits. In CE compliant installations, the lines must be neutral (earth) referenced at less than 300 Vac<sub>L-N</sub>

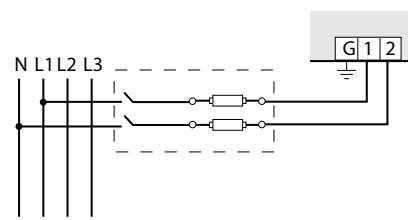

#2: Line-to-Neutral from 90 Vac to 347 Vac (UL) or 300 Vac (CE)

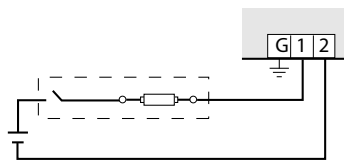

#3: DC Control power from 125 VDC to 300 VDC (UL and CE max)

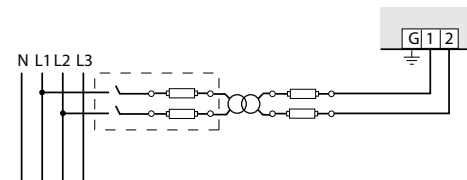

#4: Control power transformer may be wired L-N or L-L. Output to meet meter input requirements

## Fuse Recommendations

Keep the fuses close to the power source. For selecting fuses and circuit breakers, use the following criteria:

- Select current interrupt capacity based on the installation category and fault current capability
- Select over-current protection with a time delay.
- Use a voltage rating sufficient for the input voltage applied.
- Provide over-current protection and disconnecting means to protect the wiring.

**Note:** . For AC installations, use Trane AH04 or equivalent. For DC installations, provide external circuit protection. Suggested: 0.5A, time delay fuses rated for DC operation at or above the supply voltage

- Use the earth connection (G) for electromagnetic compatibility (EMC), not a protective earth ground.



# Navigating Screens and Setting Parameters

These instructions assume the meter is set to factory defaults. If it has been previously configured, all optional values should be checked.

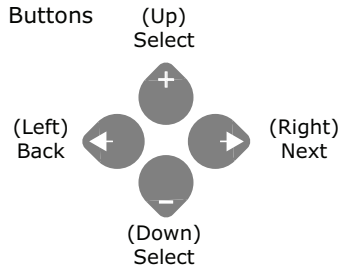

1. To Navigate to the Setup Screens:
  - a. Press the + or – button repeatedly until **SETUP** screen displays.
  - b. Press →. to advance to the **PASWD** screen.
  - c. Press →. through the digits. Press + or – buttons to select the password (the default is **00000**). Exit the screen to the right.
  - d. Press → to advance to the first setup screen (**S BAC**).
  - e. Press + or – to select the desired parameter screen to set. After setting parameters, press + or – to select the next setup screen or <- to exit and return to **SETUP**.
2. To Enter BACnet Communication Parameters:
  - a. Press + or – repeatedly until the SETUP screen displays.. . Press → to accept the value and advance to the BAUD screen. Press + or – to select the baud rate (default is 19200). Press → to advance to the PAR screen. Press + or – to select the parity (default is NONE). Press → to return to the S COM screen.
  - b. Press → to advance to the S COM (Set Communications) setup screen.
  - c. Press → to advance to the MAC screen and through the address digits. Press + or – to select the BACnet MAC address (default is **001**).
  - d. Press → to accept the value and advance to the KBAUD screen. Press + or – to select the baud rate (default is **76.8 k**).
  - e. Press → to advance to the ID1 screen and through the upper four digits of the Device Instance. Press + or – to select the ID digits. The setup screen splits the Device ID into two parts— the most significant four digits (ID1) and the least significant three digits (ID2). The E50HxA supports BACnet Device ID values from 1 to 4,193,999. Units are shipped with a factory default setting that is pseudo-randomly generated in the range from 1,000,000 to 3,097,151.
  - f. Press → to accept the value and advance to the ID2 screen and through the lower three digits of the Device Instance. Press + or – to select the ID digits.
  - g. Press → to accept the value and to return to the S BAC screen.
3. To Enter the CT Output Voltage and Input Current Ranges:
  - a. Press → to advance to the **CT SZ** screen and through the digits. Press + or – buttons to select the CT size in amps (default is **100**).
  - b. Press → to return to the **S CT** screen.
4. To Enter the Service Type to Monitor:
  - a. Press → to advance to the **S SYS** (Set System) screen.
  - b. Press → to advance to the **SYSTEM** screen. Press + or – buttons to select the configuration (default is **3LN-1N**).
  - c. Press → to return to the **S SYS** screen.





# Pulse Contact Input

The E50H2-T2 has one input with pulse accumulator as described above, and one phase loss alarm output terminal.

**Figure 3. Pulse Contact Input**

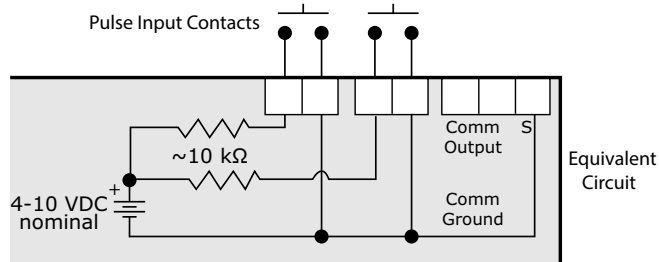



# User Interface

The user can set the display mode to either IEC or IEEE notation in the SETUP menu.

**Table 1. User Interface Menu Abbreviations**

Main Menu			Main Menu		
IEC	IEEE	Description	IEC	IEEE	Description
D	D	Demand	F ERR	F ERR	Frequency Error
MAX	M	Maximum Demand	I OVR	I OVR	Over Current
P	W	Present Real Power	V OVR	V OVR	Over Voltage
Q	VAR	Present Reactive Power	PULSE	PULSE	kWh Pulse Output Overrun (configuration error)
S	VA	Present Apparent Power	_PHASE	_PHASE	Summary Data for 1, 2, or 3 active phases
A	A	Amps	ALERT	ALERT	Diagnostic Alert Status
UAB, UBC, UAC	VAB, VBC, VAC	Voltage Line-to-Line	INFO	INFO	Unit Information
V	VLN	Voltage Line to Neutral	MODEL	MODEL	Model Number
PF	PF	Power Factor	OS	OS	Operating System
U	VLL	Voltage Line-to-Line	RS	RS	Reset System
HZ	HZ	Frequency	SN	SN	Serial Number
KSh	KVAh	Accumulated Apparent	RESET	RESET	Reset Data
KQh	KVARh	Accumulated Reactive	PASWD	PASWD	Enter Reset or Setup Password
KPh	KWh	Accumulated Real Energy	ENERG	ENERG	Reset Energy Accumulators
PLOSS	PLOSS	Phase Loss	DEMND	DEMND	Reset Demand Maximums
LOWPF	LOWPF	Low Power Factor Error			

Figure 4. Data Configuration

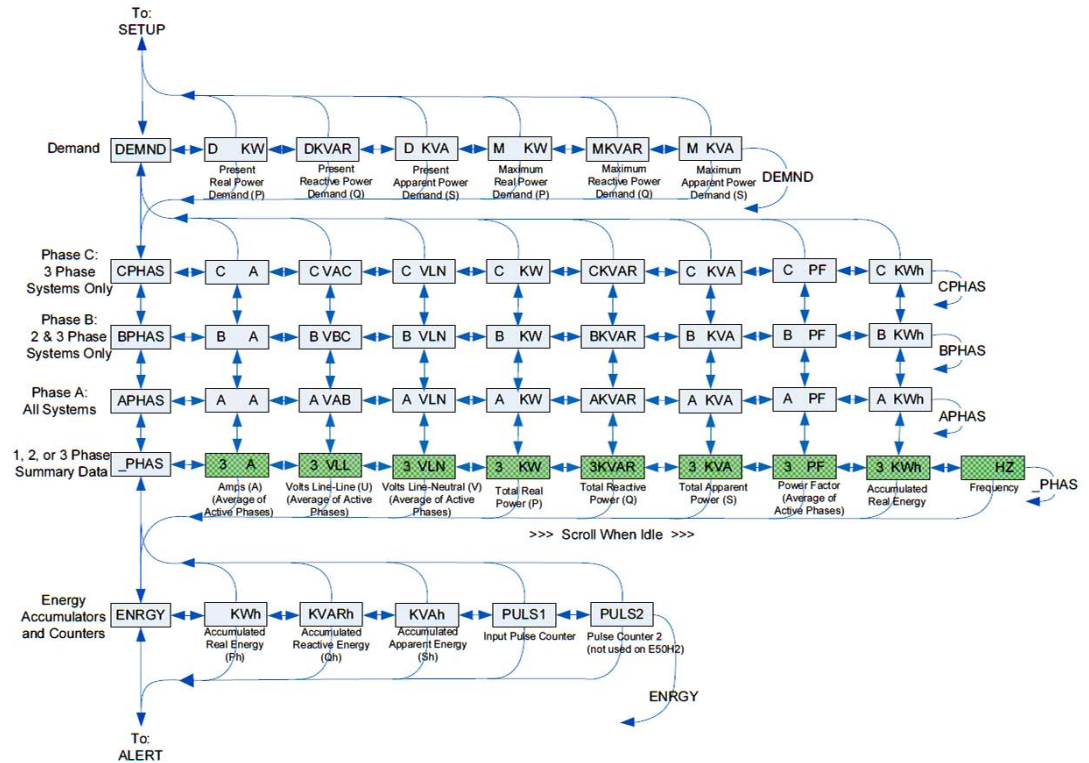

The units for all Power and Energy screens change to preserve resolution as the accumulated totals increase. For example, energy starts out as Wh, then switches to kWh, MWh, and eventually GWh as the accumulated value increases.

**Figure 5. Alert and Reset Information**

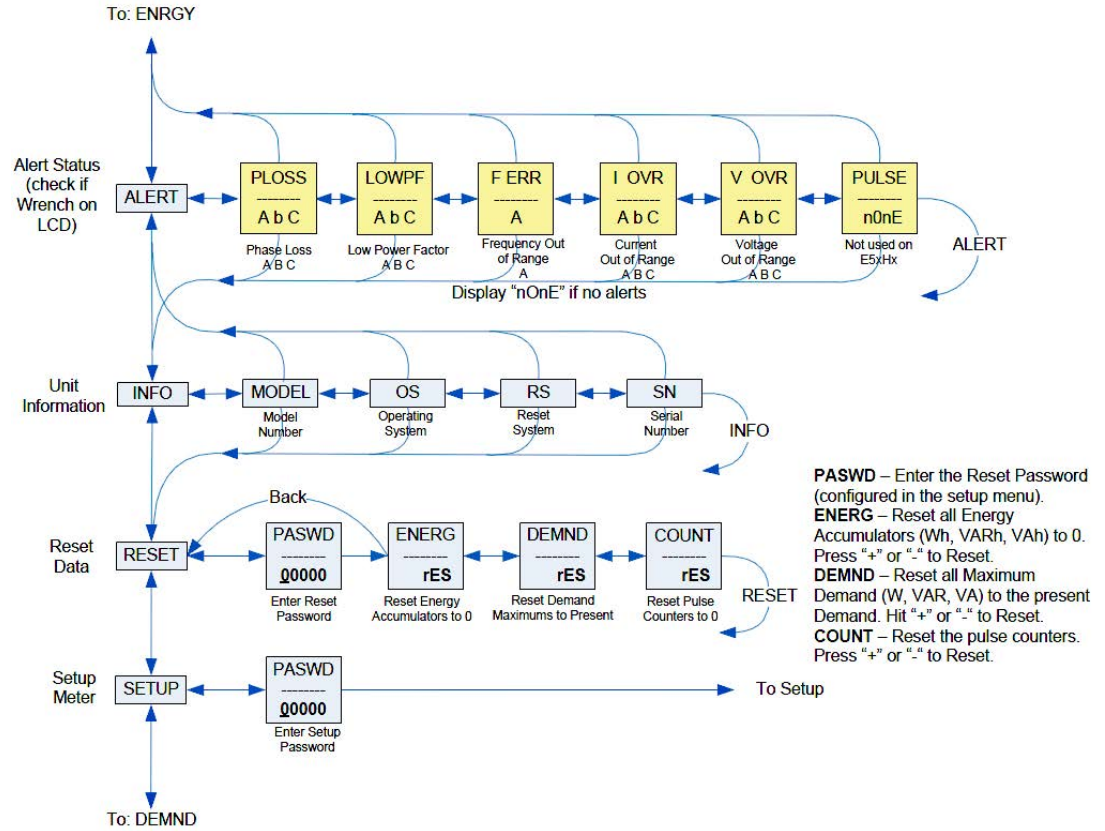

**Figure 6. User Interface for Setup**

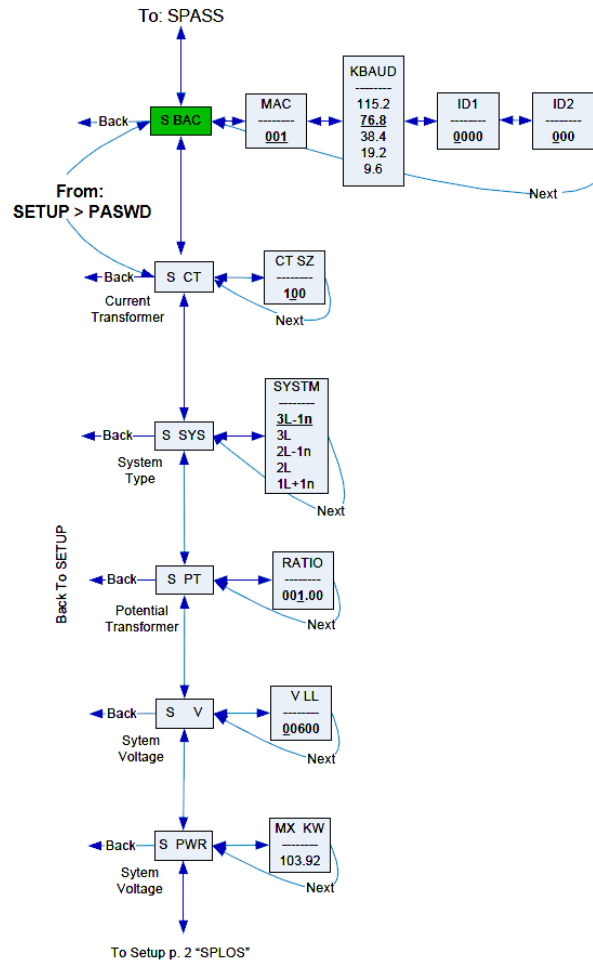

**Set Communications Parameters:**  
**ADDR** – BACnet MS/TP MAC Address: 0 – 127.  
 + increments the selected (blinking) digit.  
 – selects the digit to the left.  
**BAUD** - Baud Rate: 9600 – 115200 Baud  
**BACnet ID:** These two screens set the 7 digit BACnet device ID. Screen ID1 is the most significant 4 digits and ID2 the least significant three digits. This is in the range of 0 - 4,194,302.

**Set Current Transducer:**  
**CT SZ** - CT Size: in Amps. Maximum is 5000 Amps.

**Set System Configuration:**  
**SYSTM:** + or – to step through the following System Type options:

System	Req 130	CTs	Description
<b>3L-1n</b>	40	3	Wye Three Phase: A, B, & C with Neutral (Default).
3L	31	3	Delta Three Phase: A, B & C; no Neutral
2L-1n	12	2	Single Split Phase: A & B with Neutral
2L	11	1	Single Phase: A & B; no Neutral
1L-1n	10	1	Single Phase: A to Neutral

**Set Potential Transformer Ratio:**  
**RATIO** – Potential transformer step down is RATIO:1. Default is 1:1 (No PT installed). See Install for wiring diagrams. This value must be set before the System Voltage. (if used).

**Set System Voltage:**  
**V LL** – The nominal Line to Line Voltage for the system. This is used by the meter to calculate the theoretical maximum system power, and as the reference voltage for setting the Phase Loss threshold. Maximum is 32000 Volts. For system type 1+N (10), this is a Line to Neutral Voltage, indicated by "V LN". Note: the meter will reject settings that are not within the meter's operating range when divided by the PT ratio.

**System Power:**  
**MX KW** – The theoretical Maximum System Power is calculated by the meter from the System Voltage, CT size, and System Type. Power Factor is assumed to be unity. The value of System Power is used to determine which combinations of pulse weight and duration are valid and will keep up with the maximum power the meter will see. This value is read only.

Note: Bold is the Default.

**Figure 7. User Interface for Setup (continued)**

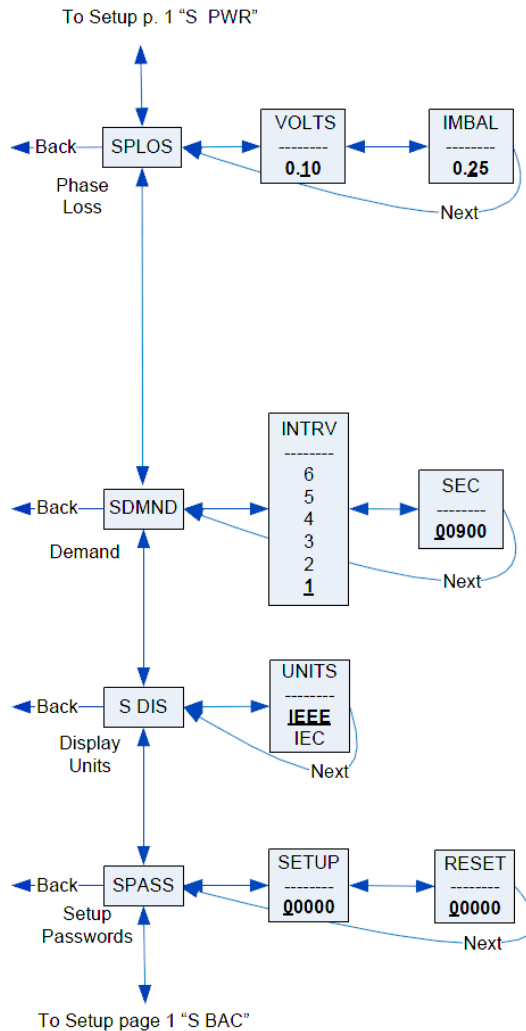

**Set Phase Loss:**

**VOLTS - Phase Loss Voltage:** The fraction of the system voltage below which Phase Loss Alarm is on. For system types with neutral, the Line to Neutral voltage is also calculated and tested. If the System Voltage is 600 and the fraction is set to 0.10, then the Phase Loss threshold will be 60 volts.

**IMBAL - Phase Loss Imbalance:** The fractional difference in Line to Line voltages above which Phase Loss Alarm is on. For system types with neutral, the Line to Neutral voltages are also tested. For system types 1+N (10) and 2 (11), imbalance is not tested.

**Set Demand Interval:**

**INTRV -** The number of Sub-Intervals (1 to 6) in a Demand Interval. Default is 1 (block demand).

**SEC -** Sub-Interval length in seconds. Default is 900 (15 minutes). Set to 0 for external sync-to-comms.

**Set Display Units: +/- to switch between:**

**IEEE -** VLL VLN W VAR VA Units.  
**IEC -** U V P Q S Units.

**Set Passwords:**

**SETUP -** The Password to enter the SETUP menu.  
**RESET -** The Password to enter the RESET menu.

## RS-485 Communications

The RS-485 secondary port allows the power meter to be connected in a daisy chain with up to 63, 2-wire devices.

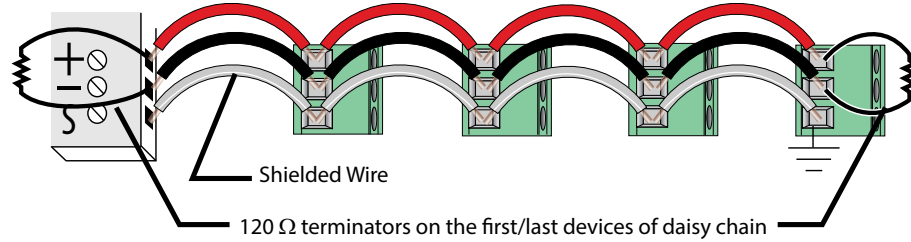

**Notes:**

- The voltage and current ratings on the terminals are compliant with the requirements of the EIA RS-485 communications standard.
- The RS-485 transceivers are ¼ unit load or less.
- RS-485+ has a 47 kΩ pull up to +5V, and RS-485- has a 47 kΩ pull down to Shield (RS-485 signal ground).
- Wire the RS-485 Bus as a daisy chain from device-to-device, without any stubs. Use 120 Ω termination resistors at each end of the bus (not included).
- Shield is not internally connected to Earth Ground.
- Connect Shield to Earth Ground somewhere on the RS-485 bus (only at one point).

**For all terminals on E50 meters:**

- When tightening terminals, apply the correct torque: 0.37-0.44 ft·lb (0.5-0.6 N·m).
- Use 14-24 gauge (2.1-0.2 mm<sup>2</sup>) wire.



## Standard BACnet Default Settings

Setting	Default Values <sup>(a)</sup>	BACnet Object
Setup Password	00000	—
Reset Password	00000	—
System Type	40 (3+N) Wye	AV2
CT Primary Ratio	100 amp	AV3
PT Ratio	1:1 (none)	AV5
System Voltage	600 V L-L	AV6
Maximum Theoretical Power	Calculated from AV2, AV3, AV4, AV5, and AV6 (with default settings, power is 103.92 kW)	AI45
Display Mode	1 (IEEE)	AV7
Phase Loss Voltage Threshold	<ul style="list-style-type: none"> <li>• 10% of system voltage</li> <li>• 25% phase-to-phase imbalance</li> </ul>	<ul style="list-style-type: none"> <li>• AV8</li> <li>• AV9</li> </ul>
Demand: Number of sub-intervals length	1 (block mode)	AV10
Demand: Sub-interval Length	900 sec (15 min)- AV11 default value is 90000 [1/100 seconds]	AV11
BACnet MAC Address	001	—
BACnet TP Baud Rate	76.8 kBaud	—
BACnet TP Max_Requestor	127	Device
BACnet Device_ID	Pseudo-random value from 1,000,000 to 3,097,151	Device
BACnet Device Location	Installed location not yet identified	Device

<sup>(a)</sup> Default values are preset at the factory. Once changed, defaults can no longer be automatically reset- they must be restored individually. The baud rate and MAC address are set through the user-interface screens, and all other values are set by re-writing each Object.





# BACnet Programming

## BACnet Programming Overview

The E50H2-T2 is programmable via BACnet protocol and can easily be connected to a BACnet TP network using an off-the shelf BACnet router. It uses five types of BACnet objects. A standard PICS (below) describes the required characteristics of the BACnet implementation, but this additional descriptive context may be helpful to the integrator.

In addition to the required properties, the device object utilizes some optional properties to support other functionality, Time Synchronization (primarily used for data/trend logging on the device) and Description and Location properties to simplify installation and maintenance. Configure all of the meter's functions, other than data logging and writable Device Properties, by writing the Present\_Value of the 11 Analog\_Value objects. These values (except for the configuration register, AV1, which always returns zero when read) are all readable and stored in nonvolatile memory so that they are retained if power to the device is interrupted.

Data values are accessed by reading the Present\_Value of the 52 Analog\_Input objects. Most of these values are instantaneous readings of measured service parameters. Some of them, (AI1, AI26, AI27, AI37-AI45, AI47, AI50 and AI51) represent accumulated values and are stored in nonvolatile memory as well. If power to the device is interrupted, these values are retained, but no additional information accumulates until the device completes its re-initialization.

Alerts are used to indicate conditions of potential concern to the installer or the system, such as input voltage or current on any phase that exceeds the meter's measurement range, phase voltage below the Phase Loss Threshold set by the user, or Power Factor below 0.5 on any phase. Alerts are accessible individually by reading the Present\_Value of the Binary\_Input objects or as a group by reading the Present\_Value of Analog\_Input object 52. Alerts are not latched and do not generate events to system. They indicate presence of these conditions at the time they are read, but the device does not latch and store them until they are read (if the condition changes before they are read, the alert will go away).

All Analog\_Value, Analog\_Input, and Binary\_Input objects implement the reliability property and use it to indicate that the Present\_Value properties are functional, valid and current. For complete assurance, check the Reliability property for a No\_Fault\_Detected status before reading the Present\_Value of any AV, AI or BI objects.

- BACnet Protocol Implementation Conformance Statement (PICS)
  - Date: January 1, 2013
  - Vendor Name: Veris Industries, LLC
  - Product Name: E50Hx Energy Meter
  - Product Model Number: E50Hx
  - Applications Software Version: 1
  - Firmware Revision: x.xxx
  - BACnet Protocol Revision: 4
  - Product Description: 3-phase electrical energy meter
- BACnet Standardized Device Profile (Annex L)
  - BACnet Application Specific Controller (B-ASC)
- List all BACnet Interoperability Building Blocks Supported (Annex K)
  - DS-RP-B, DS-RPM-B, DS-WP-B, DM-DDB-B, DM-DOB-B, DM-DCC-B, DM-TS-B, DM-RD-B
- Segmentation Capability
  - Segmentation not supported
- Standard Object Types Supported
  - **Note:** No dynamic Creation or Deletion supported; no proprietary properties or object types.
  - Device Object

- Optional Properties Supported: Max\_Requestor, Max\_Info\_Frames, Description, Location, Local\_Time, Local\_Date
- Writable Properties: Object\_Identifier, Object\_Name, Max\_Requestor, Location
- Property Range Restrictions: Object\_Identifier – May only write values from 1 to 4,193,999; Location – (limited to 64 characters); Max\_Requestor – May only write values from 1 to 127
- Analog\_Input Objects
  - Optional Properties Supported: Description, Reliability
  - No Writable Properties
- Analog\_Value Objects
  - Optional Properties Supported: Description, Reliability
  - Writable Properties: Only the Present\_Value is writable
  - Property Range Restrictions
    - AV1: May only write 30078, 21211, 21212 and 16498
    - AV2: May only write 10, 11, 12, 31 and 40
    - AV3: May only write values from 5 to 5000
    - AV4: May only write value 32768
    - AV5: May only write values from 0.01 to 320.0
    - AV6: May only write values such that AV6/AV5 is from 82 to 660 (absolute range is 82-32000). To ensure AV6 accepts/rejects the proper values, set AV5 first.
    - AV7: May only write values 0 and 1
    - AV8: May only write values from 1 to 99
    - AV9: May only write values from 1 to 99
    - AV10: May only write values from 1 to 6
    - AV11: May only write the value 0 or a value from 1000 to 3276700 in multiples of 100
  - Binary\_Input Objects
    - Optional Properties Supported: Description, Reliability
    - No writable properties
  - Data Link Layer Options
    - EIA-485 Token Passing, Requestor (Clause 9), Baud Rate(s): 9600, 19200, 38400, 76800, 115200.
  - Device Address Binding
    - Static device binding is not supported. No client functionality is included.
  - Networking Options
    - None
  - Character Sets Supported
    - ANSI X3.4

## BACnet Programming Objects

The following tables provide information about BACnet object types and descriptions.

*Legend:*

- *R = Read, R/W= Read or Write*
- *NV= Value is stored in non-volatile memory. The value(s) is still available in the event of power loss or reset.*
- *Units= Lists the physical units that a register holds.*

## Device Object

**Figure 8. Device Object**

Property	R/W	NV	Value Returned	Additional information
Object_Identifier	R/W	NV	Device<n>	n is the 7 digit ID # set in the ID1 & ID2 setup screens on the meter. The BACnet Device ID is a decimal number from 1 to 4,193,999 that can be entered or viewed on the user screens or through this property. The default value set at the factory is a pseudo-random number from 1,000,000 to 3,097,151 to reduce the likelihood of conflicts if multiple units are installed using their default IDs.
Object_Type	R	NV	Device (8)	
Object_Name	R	NV	Veris E50 Series Energy Meter - S/N: <serial number>	
Vendor_Name	R	NV	Veris Industries, LLC	
Vendor_Identifier	R	NV	133	
Model_Name	R	NV	E50HxA Energy Meter	
Firmware_Revision	R	NV	<Current Revision #>	"xyyy". This is the BACnet processor firmware version in the format <xyyy>, with an implied decimal point between the first two digits (x.yyy)
Application_Software_Version	R	NV	<Current version #>	"RS= xyyy, OS=xyyy, BACnet Gateway=xyyy" The format <xyyy> has an implied decimal point between the first two digits (x.yyy)
Location	R/W	NV	<Location>	Limited to 64 Characters - Default value is "Installed location not yet identified"
Description	R	NV	Veris E50HxA DIN-Rail Energy Meter S/N: <serial number>	
Protocol_Version	R	NV	1	BACnet Protocol Version 1
Protocol_Revision	R	NV	4	BACnet Protocol Revision 4
Local_Date	R		Date	Set via BACnet Time Synchronization only - reverts to Jan 1, 2000 if control power drops
Local_Time	R		Time	Set via BACnet Time Synchronization only - reverts to 12:00:00 AM if control power drops
Segmentation_Supported	R	NV	NO_SEGMENTATION (3)	Segmentation is not supported
Max_Master	R/W	NV	1-127 (Factory Default is 127)	Highest possible MAC Address for Master nodes on the local MS/TP network
Max_Info_Frames	R	NV	1	Maximum number of information frames allowed before passing the MS/TP token
Max_APDU_Length_Accepted	R	NV	480	
APDU_Timeout	R	NV	60000	
Number_of_APDU_Retries	R	NV	0	
System_Status	R	NV	Operational (0)	
Protocol_Services_Supported	R	NV	0b000000000000101101000000000000 011110000	
Protocol_Object_Types_Supported	R	NV	0b101100001000000000010000000000	

**Figure 9. Device Object (continued)**

Property	R/W	NV	Value Returned	Additional information
Object_List	R	NV	DE1, AI1, AI2, AI3, AI4, AI5, AI6, AI7, AI8, AI9, AI10, AI11, AI12, AI13, AI14, AI15, AI16, AI17, AI18, AI19, AI20, AI21, AI22, AI23, AI24, AI25, AI26, AI27, AI28, AI29, AI30, AI31, AI32, AI33, AI34, AI35, AI36, AI37, AI38, AI39, AI40, AI41, AI42, AI43, AI44, AI45, AI46, AI47, AI48, AI49, AI50, AI51, AI52, AV1, AV2, AV3, AV4, AV5, AV6, AV7, AV8, AV9, AV10, AV11, BI1, BI2, BI3, BI4, BI5, BI6, BI7, BI8, BI9, BI10, BI11, BI12, BI13, BI14, BI15	
Device_Address_Binding	R	NV	{}	
Database_Revision	R	NV	0	

## Analog Value (AV) Objects

Use the Present\_Value property of the Analog\_Value object for all writable variables in the meter other than those used specifically for BACnet configuration, Time Synchronization (in the Device Object).

Values are checked when written, and errors are returned for invalid entries. This table describes how the meter uses those variables, what values are valid, and what their defaults are. When writing values to the Present\_Value properties of Analog\_Value BACnet objects, there is a delay of up to about two seconds to validate and store the new value. An immediate read of the same property before that delay has elapsed can return the prior value (even if the new value was accepted). To read a value immediately after writing it, check the Reliability property first. When it reports a No\_Fault\_Detected status, the Present\_Value of the object is current. These objects

support the Description and Reliability object properties and all required Analog\_Value object properties, but Present\_Value is the only writable property.

**Figure 10. Analog Values (AV)**

#	Name	Description	R/W	NV	Units	Range	Factory Default Value	Additional information
AV1	Config	Configuration	R/W		n/a	n/a	Always returns "0" when read	Command Register: - Write 30078 (0x757E) to clear all energy accumulators to 0 (All). - Write 21211 (0x52DB) to begin new Demand Sub-Interval calculation cycle and log another data value on Trend_Log objects TL1-TL3 (when the meter is in Manual "Sync-to Comms" mode). This takes effect at the end of the next 1 second calculation cycle. Write no more frequently than every 10 seconds. - Write 21212 (0x52DC) to reset Max Demand values to Present Demand Values. Takes effect at the end of the next 1 second calculation cycle. Write no more frequently than every 10 seconds. - Write 16498 (0x4072) to clear pulse counters to 0.
AV2	System_Type	System Type	R/W	NV	n/a	40, 31, 12, 11, 10	40	System_Type: - Write 10 for Single-Phase: A + N - Write 11 for Single-Phase: A + B - Write 12 for Split-Phase: A + B + N - Write 31 for 3-Phase Δ: A + B + C, no N - Write 40 for 3-Phase Y: A + B + C + N
AV3	CT_Ratio_Primary	CT Ratio - Primary	R/W	NV	Amps	5-5000	100	Current Transducer Size - Primary Current Range (Default is set for 100 A CTs)
AV4	CT_Ratio_Secondary	CT Ratio - Secondary	R	NV	n/a	n/a	1	Reserved
AV5	PT_Ratio	PT Ratio	R/W	NV	Value	0.01 - 320.0	1	Potential Transformer Ratio - The default is 1.00 (1:1), which is no PT attached. Set this value before setting the System Voltage (below).

**Figure 11. Analog Values (AV) [continued]**

#	Name	Description	R/W	NV	Units	Range	Factory Default Value	Additional information
AV6	System_Voltage	System Voltage	R/W	NV	Volts	from 82 (times the PT_Ratio in AV5) to 660 (times the PT_Ratio in AV5 - absolute limits are 82-32000)	600	System Voltage - This voltage is Line to Line unless in System Type 10 (in object AV2), in which case it is Line to Neutral. This value is used by the meter to calculate the full scale power for the analog outputs and pulse configuration (see below), and as full scale for phase loss (in object AV8). Do not set the meter to voltages outside the range of 82-660 volts times the PT Ratio in object AV5.
AV7	Display_Units	Display Units	R/W	NV	n/a	0,1	1	Display Units: 0 = IEC (U, V, P, Q, S), 1 = IEEE (default: VLL, VLN, W, VAR, VA)
AV8	Phase_Loss_Voltage_Threshold	Phase Loss Voltage Threshold	R/W	NV	Percent	1-99	10	Phase Loss Voltage Threshold in percent of System Voltage (in object AV6). Default is 10 (10%). Any phase (as configured in AV2) whose level drops below this threshold triggers a Phase Loss alert - i.e. if the System voltage is set to 480 V L-L, the L-N voltage for each phase should be 277 V. When the threshold is set to 10%, if any phase drops more than 10% below 277 V, (less than 249 V), or if any L-L voltage drops more than 10% below 480 V (less than 432 V) the corresponding phase loss alarm bit will be true.
AV9	Phase_Loss_Imbalance_Threshold	Phase Loss Imbalance Threshold	R/W	NV	Percent	1-99	25	Phase Loss Imbalance Threshold in Percent. Default is 25% phase to phase difference. For a 3-phase Y (3 + N) system type (40 in object AV2), both Line to Neutral and Line to Line voltages are tested. In a 3-phase Δ system type (31 in object AV2), only Line to Line voltages are examined. In a single split-phase (2 + N) system type (12 in object AV2), only the line to neutral voltage are compared.
AV10	Subintervals	Number Subintervals Per Demand Interval	R/W	NV		1-6	1	Number of Sub-Intervals per Demand Interval. Sets the number of sub-intervals that make a single demand interval. For block demand, set this to 1. Default is 1. When Sub-Interval Length (in object AV11) is set to 0 (sync-to-comms mode), the meter ignores this value.
AV11	Subinterval_Length	Subinterval Length	R/W	NV	hundredths of a second	0, 10-32767	90000	Sub-Interval Length in hundredths of a second. For sync-to-comms mode, which allows manual triggering of demand intervals, set this value to 0 and write 21211 to the reset register (object AV1) each time the sub-interval must be externally reset. Default is 90000 (15 minutes). Changing any of these four properties changes all of them.

## Analog Input (AI) Objects

Use the Present\_Value property of the Analog\_Input objects for all read-only numeric variables in the meter other than those used specifically for device configuration (in the Device Object).

These objects support the Description and Reliability object properties and all required Analog\_Input object properties. None of them are writable. The values that are not instantaneous (i.e., Accumulated Energy, Max Demand, Pulse Input Counts) are non-volatile. They are not updated while control power is inactive, but their past values are retained when power is restored. The Present\_Value of the accumulated data objects (AI1, AI26-AI27 and AI42-AI44) use floating-point

data types (all AI objects use floating point data points). The resolution of the accumulated values decreases as the value grows larger over time and more of the significant digits precede the decimal point. If the size of the value limits the resolution unacceptably, read and store the current value offline and reset the accumulators to restore finer resolution.

**Note:** As a best practice, verify the Reliability property for a No\_Fault\_Detected status before reading the Present\_Value. If the line voltage or input frequency of the system being monitored falls out of the supported range, the corresponding alert bits (BI1-BI7) are set and the reliability property of any values that cannot be accurately measured under those conditions returns Unreliable\_Other.

**Figure 12. Analog Inputs (AI)**

#	Object_Name	Description	R/W	NV	Units	Range	Additional Information
AI1	Energy	Real Energy Consumption	R	NV	kWh	0 - 3.4+E38	
AI2	kW_Total	Total Real Power	R		kW	0 - Max_Power (AI45)	
AI3	KVAR_Total	Total Reactive Power	R		KVAR	0 - Max_Power (AI45)	
AI4	kVA_Total	Total Apparent Power	R		kVA	0 - Max_Power (AI45)	
AI5	PF_Total	Total Power Factor	R		Power Factor	0.00 - 1.00	1.00 for 100%
AI6	Volts_LL_Avg	Voltage L-L Average	R		Volts		
AI7	Volts_LN_Avg	Voltage L-N Average	R		Volts		
AI8	Current_Avg	Current Average	R		Amps		
AI9	kW_A	Real Power Phase A	R		kW	0 - Max_Power (AI45)	
AI10	kW_B	Real Power Phase B	R		kW	0 - Max_Power (AI45)	
AI11	kW_C	Real Power Phase C	R		kW	0 - Max_Power (AI45)	
AI12	PF_A	Power Factor Phase A	R		Power Factor	0.00 - 1.00	1.00 for 100%
AI13	PF_B	Power Factor Phase B	R		Power Factor	0.00 - 1.00	1.00 for 100%
AI14	PF_C	Power Factor Phase C	R		Power Factor	0.00 - 1.00	1.00 for 100%
AI15	Volts_AB	Voltage Phase A-B	R		Volts		
AI16	Volts_BC	Voltage Phase B-C	R		Volts		
AI17	Volts_AC	Voltage Phase A-C	R		Volts		
AI18	Volts_AN	Voltage Phase A-N	R		Volts		
AI19	Volts_BN	Voltage Phase B-N	R		Volts		
AI20	Volts_CN	Voltage Phase C-N	R		Volts		
AI21	Current_A	Current Phase A	R		Amps		
AI22	Current_B	Current Phase B	R		Amps		
AI23	Current_C	Current Phase C	R		Amps		
AI24	Reserved_AI24	Reserved	R		n/a		Returns QNAN or any value
AI25	Frequency	Frequency	R		Hz	45.0-65.0	Returns QNAN if frequency is out of range (or no voltage input present on Phase A)

**Figure 13. Analog Inputs (AI) [continued]**

#	Object Name	Description	R/W	NV	Units	Range	Additional Information
AI26	kVAh	Apparent Energy Consumption	R	NV	kVAh	0 - 3.4+E38	The UNITS property of object AI26 reports that these units are kWh because there is no unit type in the BACnet standard for kVAh.
AI27	kVARh	Reactive Energy Consumption	R	NV	kVARh	0 - 3.4+E38	The UNITS property of object AI27 reports that these units are kWh because there is no unit type in the BACnet standard for kVARh.
AI28	kVA_A	Apparent Power Phase A	R		kVA	0 - Max_Power (AI45)	
AI29	kVA_B	Apparent Power Phase B	R		kVA	0 - Max_Power (AI45)	
AI30	kVA_C	Apparent Power Phase C	R		kVA	0 - Max_Power (AI45)	
AI31	kVAR_A	Reactive Power Phase A	R		kVAR	0 - Max_Power (AI45)	
AI32	kVAR_B	Reactive Power Phase B	R		kVAR	0 - Max_Power (AI45)	
AI33	kVAR_C	Reactive Power Phase C	R		kVAR	0 - Max_Power (AI45)	
AI34	KW_Present_Demand	Total Real Power Present Demand	R		kW	0 - Max_Power (AI45)	
AI35	KVAR_Present_Demand	Total Reactive Power Present Demand	R		kVAR	0 - Max_Power (AI45)	
AI36	KVA_Present_Demand	Total Apparent Power Present Demand	R		kVA	0 - Max_Power (AI45)	
AI37	KW_Max_Demand	Total Real Power Maximum Demand	R	NV	kW	0 - Max_Power (AI45)	This retains the largest value measured for Total Real Power Demand (AI34) for any single demand interval since the Max Demand were last explicitly reset via AV1 (this is also reset when the demand interval is changed).
AI38	KVAR_Max_Demand	Total Reactive Power Maximum Demand	R	NV	kVAR	0 - Max_Power (AI45)	This retains the largest value measured for Total Reactive Power Demand (AI35) for any single demand interval since the Max Demand were last explicitly reset via AV1 (this is also reset when the demand interval is changed).
AI39	KVA_Max_Demand	Total Apparent Power Maximum Demand	R	NV	kVA	0 - Max_Power (AI45)	This retains the largest value measured for Total Apparent Power Demand (AI36) for any single demand interval since the Max Demand were last explicitly reset via AV1 (this is also reset when the demand interval is changed).
AI40	E50H2: Pulse Count E50H5: Pulse_Count_1	Pulse Count	R	NV	#	0 - 4294967040	Running count of contact closures on Pulse1 input since last reset. Write 16498 (0x4072) to the Present_Value property of Analog_Value object AV1 to reset both Pulse Counters to 0.
AI41	E50H2: Reserved E50H5: Pulse_Count_2	Reserved	R	NV	#	0 - 4294967040	Reserved
AI42	KWH_A	Real Energy Consumption Phase A	R	NV	kWh	0 - 3.4+E38	

Figure 14. Analog Inputs (AI) [continued]

#	Object_Name	Description	R/W	NV	Units	Range	Additional information
AI43	KWH_B	Real Energy Consumption Phase B	R	NV	kWh	0 - 3.4+E38	
AI44	KWH_C	Real Energy Consumption Phase C	R	NV	kWh	0 - 3.4+E38	
AI45	Max_Power	Theoretical Maximum System Power	R	NV	kW	0 - 1.84467e19	Theoretical Maximum System Power – This is the theoretical maximum power the meter expects to see on a service. It is calculated by the meter from the System Type (in object AV2), CT Size (in object AV3), and System Voltage (in object AV6) - Power Factor is assumed to be unity. The register is updated whenever the user changes any of these parameters.
AI46	Reserved_AI46	Reserved	R				Returns QNAN or any value
AI47	Energy Resets	Count of Energy Accumulator Resets	R	NV		0 - 32767	Running count of how many times the energy counter has been reset
AI48	Reserved_AI48	Reserved	R				Returns QNAN or any value
AI49	Reserved_AI49	Reserved	R				Returns QNAN or any value
AI50	Power Up Count	Power Up Counter	R	NV		0 - 32767	Running count of product power-up cycles (Control Power)
AI51	Output Config	Output Configuration	R	NV		0 - 15	E50H2A-T2 returns "11"
AI52	Alarm_Bitmap	Alarm_Bitmap	R			0 - 32767	This contains a decimal value that represents the status of all Binary_Object alert values in one number that can be read without having to access multiple objects (the E50H2A-T2 has 14 values). It is a decimal representation of a 14-bit or 15-bit hexadecimal value produced by combining the alert bits into one number, where the bit value of Object BI1 is the least significant bit and BI14 is the most significant bit.

## Binary Input (BI) Objects

Use the Present\_Value properties of the Binary\_Input objects as alerts for conditions of potential concern regarding to the system measurement. These values are dynamic and are not latched, so if the condition is resolved, the alert goes inactive, whether it has been read or not.

These objects support the Description and Reliability object properties and all required Binary\_Input object properties. None of them are writable. For complete assurance, check the Reliability property for a No\_Fault\_Detected status before reading the Present\_Value.

To test the meter's alert status, read the Present\_Value of each of the Binary\_Input objects representing the alert bits of interest, or read the Present\_Value of AI52, which combines all these bits into a single decimal value. AI52 represents the status of all 14 Binary\_Object alert values in one number that can be read without having to access multiple objects. The bit value of Object BI1 is the least significant bit and BI14 is the most significant bit.

Figure 15. Binary Inputs (BI)

#	Name	Description	R/W	Range	Additional information
BI1	Volts_Error_A	Voltage Out of Range Phase A	R	0=INACTIVE, 1=ACTIVE	Phase A Input Voltage exceeds meter's measurement range
BI2	Volts_Error_B	Voltage Out of Range Phase B	R	0=INACTIVE, 1=ACTIVE	Phase B Input Voltage exceeds meter's measurement range
BI3	Volts_Error_C	Voltage Out of Range Phase C	R	0=INACTIVE, 1=ACTIVE	Phase C Input Voltage exceeds meter's measurement range
BI4	Current_Error_A	Current Out of Range Phase A	R	0=INACTIVE, 1=ACTIVE	Phase A Current out of range
BI5	Current_Error_B	Current Out of Range Phase B	R	0=INACTIVE, 1=ACTIVE	Phase B Current out of range
BI6	Current_Error_C	Current Out of Range Phase C	R	0=INACTIVE, 1=ACTIVE	Phase C Current out of range
BI7	Frequency_Error	Frequency Error	R	0=INACTIVE, 1=ACTIVE	Phase A Frequency out of range
BI8	Reserved_BI8	Reserved	R	0=INACTIVE, 1=ACTIVE	Returns "INACTIVE"
BI9	Phase_Loss_A	Phase Loss Phase A	R	0=INACTIVE, 1=ACTIVE	Phase Loss - Phase A voltage dropped below the Phase Loss Threshold set by user
BI10	Phase_Loss_B	Phase Loss Phase B	R	0=INACTIVE, 1=ACTIVE	Phase Loss - Phase B voltage dropped below the Phase Loss Threshold set by user
BI11	Phase_Loss_C	Phase Loss Phase C	R	0=INACTIVE, 1=ACTIVE	Phase Loss - Phase C voltage dropped below the Phase Loss Threshold set by user
BI12	Power_Factor_A	Low Power Factor Phase A	R	0=INACTIVE, 1=ACTIVE	Phase A Power Factor less than 50% (commonly due to mis-wiring of CTs/PTs to meter)
BI13	Power_Factor_B	Low Power Factor Phase B	R	0=INACTIVE, 1=ACTIVE	Phase B Power Factor less than 50% (commonly due to mis-wiring of CTs/PTs to meter)
BI14	Power_Factor_C	Low Power Factor Phase C	R	0=INACTIVE, 1=ACTIVE	Phase C Power Factor less than 50% (commonly due to mis-wiring of CTs/PTs to meter)



# Troubleshooting

Problem	Cause	Solution
The maintenance wrench icon appears in the power meter display.	There is a problem with the inputs to the power meter.	Refer to the Alert sub-menu or Diagnostic Alert Modbus Register 146.
The display is blank after applying.	The meter is not receiving adequate power.	<ul style="list-style-type: none"> <li>Verify that the meter control power are receiving the required voltage.</li> <li>Verify that the heart icon is blinking. Check the fuse.</li> </ul>
The data displayed is inaccurate.	Incorrect setup values.	Verify the values entered for power meter setup parameters (CT and PT ratings, system type, etc.).
	Incorrect voltage inputs.	Check power meter voltage input terminals to verify adequate voltage.
	Power meter is wired improperly.	Check all CTs and PTs to verify correct connection to the same service, PT polarity, and adequate powering.
Cannot communicate with power meter from a remote personal computer.	Power meter address is incorrect.	Verify that the meter is correctly addressed.
	Power meter baud rate is incorrect.	Verify that the baud rate of the meter matches that of all other devices on its communications link.
	Communications lines are improperly connected.	<ul style="list-style-type: none"> <li>Verify the terminating resistors are properly installed on both ends of a chain of units. Units in the middle of a chain should not have a terminator.</li> <li>Verify the power meter communications connections.</li> <li>Verify the shield ground is connected between all units.</li> </ul>





# China RoHS Compliance

Hazardous Substances						
Part Name	Pb	Hg	Cd	Cr, VI	PBB	PBDE
Electronic	X <sup>(a)</sup>	O <sup>(b)</sup>	O	O	O	O

<sup>(a)</sup> X indicates that concentration of hazardous substance in at least one of the homogeneous materials used for this part is above the limit as stipulated in GB/T 26572.

<sup>(b)</sup> O indicates that the concentration of hazardous substance in all of the homogeneous materials for this part is below the limit as stipulated in GB/T 26572.



## Additional Resources

- E50 Series Compact Power and Energy Meter, **BACnet (E50H2-T2)** and Modbus (E50C2-T2), Installation Instructions (X39641310001)
- Product Data Sheet Enhanced Power and Energy Meters E50 Series Models, Product Data Sheet (BAS-PRD035)
- Quick Installation Guide (Z207411-0A 0217)



Trane - by Trane Technologies (NYSE: TT), a global innovator - creates comfortable, energy efficient indoor environments for commercial and residential applications. For more information, please visit [trane.com](http://trane.com) or [tranetechnologies.com](http://tranetechnologies.com).

Trane has a policy of continuous product and product data improvements and reserves the right to change design and specifications without notice. We are committed to using environmentally conscious print practices.

BAS-SVX076C-EN 22 Apr 2021  
Supersedes BAS-SVX076B-EN (April 2020)

©2021 Trane