



# Installation, Operation, and Maintenance

## Tracer® UC400/UC400-B

### Programmable Controller

#### Water Source Heat Pump (WSHP)

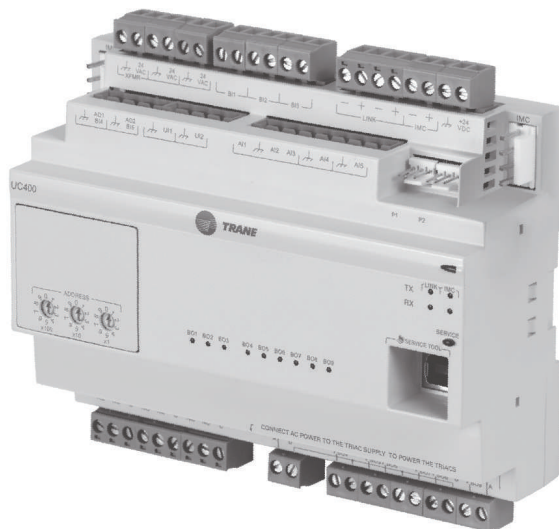

### **⚠ SAFETY WARNING**

Only qualified personnel should install and service the equipment. The installation, starting up, and servicing of heating, ventilating, and air-conditioning equipment can be hazardous and requires specific knowledge and training. Improperly installed, adjusted or altered equipment by an unqualified person could result in death or serious injury. When working on the equipment, observe all precautions in the literature and on the tags, stickers, and labels that are attached to the equipment.



# Introduction

**Note:** *Specific reference to either UC400 or UC400-B is made throughout this document. All other content cited in this document about the UC400 is referred to as **UC400 Controller**.*

The UC400/UC400-B is a multi-purpose, programmable (or application-specific) that provides direct-digital zone temperature control. This controller can operate as a stand-alone device or as part of a building automation system (BAS). Communication between the controller and a BAS occurs on an open standard with inter-operable protocols used in Building Automation and Control Networks (BACnet®). Programming is done by means of the Tracer® TU service tool.

This guide provides installation and configuration information for the UC400 Controller with specific operation description for Water Source Heat Pump (WSHP).

## Copyright

This document and the information in it are the property of Trane, and may not be used or reproduced in whole or in part without written permission. Trane reserves the right to revise this publication at any time, and to make changes to its content without obligation to notify any person of such revision or change.

## Trademarks

All trademarks referenced in this document are the trademarks of their respective owners.

## Agency Listings and Compliance

The European Union (EU) Declaration of Conformity is available from your local Trane® office.

## Revision History

Updated model number size for constant torque supply fan default settings.



# Table of Contents

|   |    |
|---|----|
| BACnet® Protocol .....                                      | 5  |
| BACnet® Testing Laboratory (BTL) Certification .....        | 5  |
| Specifications and Dimensions .....                         | 6  |
| Device Connections .....                                    | 8  |
| Additional Components .....                                 | 10 |
| Water, Discharge, and Outdoor Air Temperature Sensors ..... | 10 |
| Binary Input Switching Devices .....                        | 10 |
| Zone Temperature Sensors .....                              | 10 |
| Valve and Damper Actuators .....                            | 11 |
| Zone Humidity Sensor .....                                  | 11 |
| Expansion Modules .....                                     | 11 |
| Typical Applications and Terminations .....                 | 12 |
| Binary Inputs .....   | 14 |
| BI1; Occupancy .....  | 14 |
| BI2; Compressor 1 Protection Status .....                   | 14 |
| BI3; Compressor 2 Protection Status .....                   | 14 |
| BI3/BI4; Frost Detection .....                              | 14 |
| BI5; Fan Status .....                                       | 14 |
| Analog Inputs .....   | 14 |
| Ground Terminals .....                                      | 14 |
| AI1; Space Temperature .....                                | 15 |
| AI2; Space Temperature Local Setpoint .....                 | 15 |
| AI3; Local Fan Mode Input .....                             | 15 |
| AI4; Discharge Air Temperature Sensor .....                 | 15 |
| AI5; Entering Water Temperature .....                       | 15 |
| Universal Inputs .....                                      | 16 |
| UI1; Leaving Water Temperature .....                        | 16 |
| UI2; Relative Humidity or CO <sub>2</sub> Sensor .....      | 16 |
| Pressure Inputs .....                                       | 16 |
| PI1; Condensate Overflow .....                              | 16 |
| Wiring Requirements .....                                   | 16 |
| UC400 Wiring Diagrams .....                                 | 17 |
| UC400–B Wiring Diagrams .....                               | 22 |
| Wiring Installation .....                                   | 27 |
| Connecting Wires to Terminals .....                         | 27 |
| BACnet MS/TP Link .....                                     | 27 |
| MAC Address .....   | 27 |
| BACnet Device ID .....                                      | 27 |
| BACnet Networks, With or Without Tracer SC Controller ..... | 27 |
| Without a Tracer SC Controller .....                        | 27 |

|  |    |
|--|----|
| With a Tracer SC Controller . . . . .                      | 27 |
| BACnet MS/TP Link Wiring . . . . .                         | 28 |
| Power Supply . . . . .                                     | 29 |
| Transformer Recommendations . . . . .                      | 29 |
| Wiring Requirements . . . . .                              | 29 |
| Connecting 24 Vac Secondary Wires . . . . .                | 30 |
| Power On Check . . . . .                                   | 31 |
| LED Description, Activities, and Troubleshooting . . . . . | 32 |
| Sequence of Operation . . . . .                            | 35 |
| Power-up Sequence . . . . .                                | 35 |
| Random Start . . . . .                                     | 35 |
| Occupancy Modes . . . . .                                  | 35 |
| Occupied Mode . . . . .                                    | 36 |
| Unoccupied Mode . . . . .                                  | 36 |
| Occupied Standby Mode . . . . .                            | 36 |
| Occupied Bypass Mode . . . . .                             | 36 |
| Timed Override Control . . . . .                           | 37 |
| Heat/Cool Operation . . . . .                              | 37 |
| Fan Operation . . . . .                                    | 37 |
| Single-Zone VAV/Variable Speed Fan Operation . . . . .     | 37 |
| Entering Water Temperature Sampling Function . . . . .     | 40 |
| Electric Heat Operation . . . . .                          | 42 |
| Other Modes . . . . .                                      | 43 |
| Operational Troubleshooting . . . . .                      | 46 |
| Diagnostics . . . . .                                      | 46 |
| Override Outputs . . . . .                                 | 47 |
| Resetting Diagnostics . . . . .                            | 49 |
| High/Low Pressure Cutout . . . . .                         | 49 |
| Manual Output Test . . . . .                               | 49 |
| Cycling Power . . . . .                                    | 49 |
| Building Automation System (BAS) . . . . .                 | 49 |
| Tracer TU Service Tool . . . . .                           | 49 |
| Cycling the Fan Switch . . . . .                           | 49 |
| Operational Causes and Diagnostics . . . . .               | 50 |
| Configuration and Maintenance . . . . .                    | 53 |
| Resources . . . . .  | 55 |



## BACnet® Protocol

The Building Automation and Control Network (BACnet®) protocol is ANSI/ASHRAE Standard 135. This standard allows building automation systems or components from different manufacturers to share information and control functions. BACnet® provides building owners the capability to connect various types of building control systems or subsystems together for many uses. Multiple vendors can use this protocol to share information for monitoring and supervisory control between systems and devices in a multi-vendor interconnected system. The BACnet® protocol defines standard objects (data points) called BACnet® objects. Each object has a defined list of properties that provide context information about that object. In addition, BACnet® defines a number of application services that are used to interact with objects in a BACnet® device.

## BACnet® Testing Laboratory (BTL) Certification

The UC400 Controller supports the BACnet communication protocol and has been designed to meet the requirements of the application-specific control profile. For more details, refer to the BTL web site at [www.bacnetinternational.org](http://www.bacnetinternational.org). The UC400 Controller supports the following equipment when used as an application-specific unit:

- Blower Coils
- Fan Coils
- Unit Ventilators
- WSHP
- VAV



# Specifications and Dimensions

**Table 1. UC400/UC400–B specifications**

| Storage  |   |
|--|---|
| Temperature:   | –48°F to 203°F (–44°C to 95°C)  |
| Relative Humidity:   | Between 5% and 95% (non-condensing)   |
| Operating  |   |
| Temperature:   | –40°F to 158°F (–40°C to 70°C)  |
| Humidity:  | Between 5% and 95% (non-condensing)   |
| Input Power:   | 20.4–27.6 Vac (24, ±15% nominal), 50Hz to 60Hz, 24 VA<br>(24 VA plus binary output loads for a maximum of 12 VA for each binary output) |
| Mounting Weight of Controller:   | Supporting mounting surface: must be 0.80 lb. (.364 kg)   |
| Environmental Rating (Enclosure):  | NEMA 1  |
| Altitude:  | 6,500 ft. maximum (1,981 m)   |
| Installation:  | U.L. 840: Category 3  |
| Pollution:   | U.L. 840: Degree 2  |
| Housing Material: <sup>(a)</sup>   | Polycarbonate/ABS Blend<br>UV protected<br>U.L. 94-5VA flammability rating  |
| Mounting:  | <b>UC400:</b> Mounts on EN 50 022 - 35 X 15 DIN rail.<br><b>UC400–B:</b> Pre-mounted.   |
| Agency Listing   |   |
| UL916 PAZX, Open Energy Management Equipment<br>UL94-5V, Flammability<br>CE Marked<br>FCC Part 15, Subpart B, Class B Limit<br>AS/NZS CISPR 22:2006<br>VCCI V-3/2008.04<br>ICES-003, Issue 4:2004<br>Communications BACnet <sup>®</sup> MS/TP, supports BACnet Protocol ASHRAE 135-2004 and Meets BACnet Testing Laboratory (BTL) as an Application Specific Controller (ASC) Profile Device |   |

<sup>(a)</sup> Not applicable for the UC400-B model.

**Figure 1. UC400 and UC400-B dimensions**

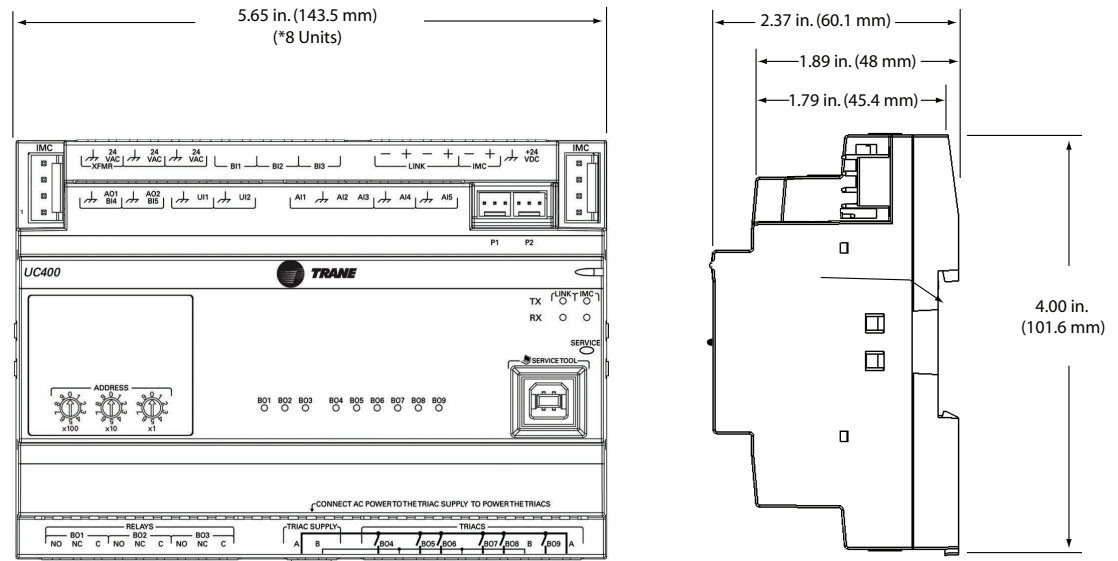

\*DIN Standard 43 880, Built-in Equipment for Electrical Installation. Overall Dimensions and Related Mounting Dimensions.

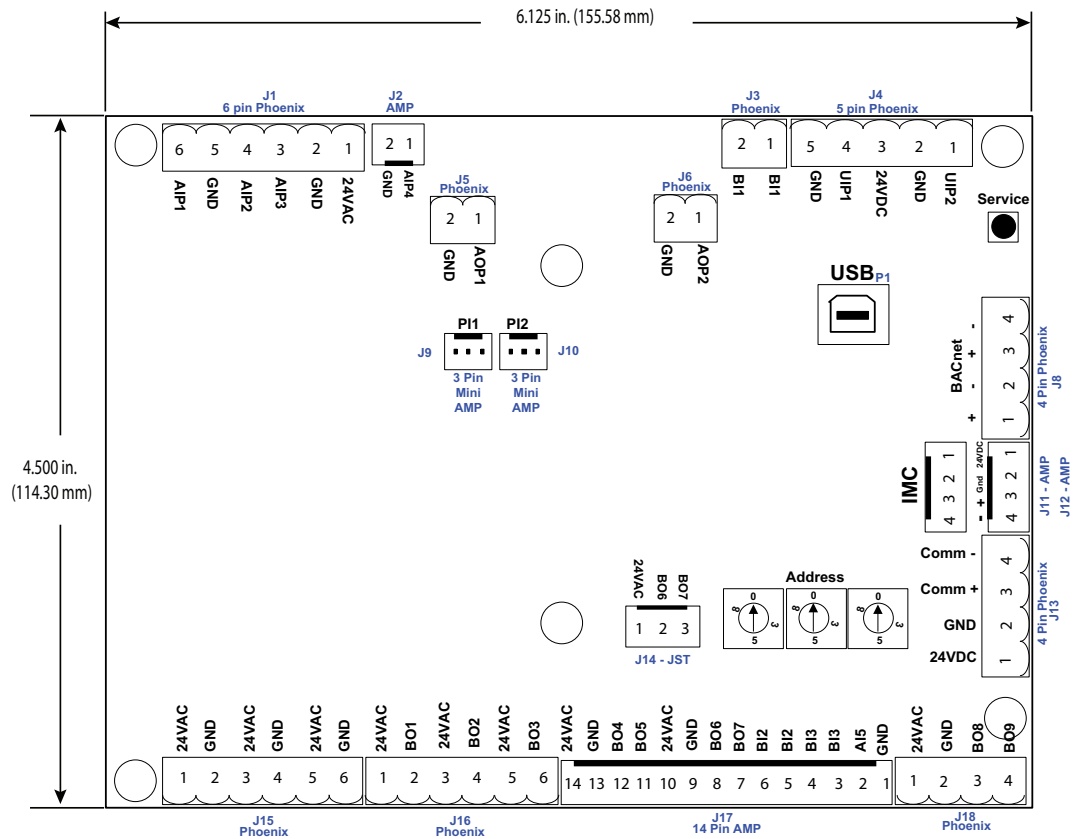



# Device Connections

The following table provides details of the hardware termination configuration options. The hardware terminations are pre-configured for proper equipment operation for blower coil/fan coil applications.

**⚠ WARNING**

**Live Electrical Components!**  
 Failure to follow all electrical safety precautions when exposed to live electrical components could result in death or serious injury.  
 When it is necessary to work with live electrical components, have a qualified licensed electrician or other individual who has been properly trained in handling live electrical components perform these tasks.

**Table 2. Connections**

| Connection                                | Quantity     | Types                | Range  | Notes  |
|---|--------------|----------------------|--|--|
| Analog input (AI1 to AI5)                 | 5            | Temperature          | 10 kΩ thermistor   | AI1 to AI4 can be configured for timed override capability.  |
|   |              | Setpoint             | 189 Ω to 889 Ω   |  |
|   |              | Resistive            | 100 Ω to 100 kΩ  | Typically used for fan speed switch.   |
| Universal input (UI1 and UI2)             | 2            | Linear               | 0–20 mA  | These inputs may be configured to be thermistor or resistive inputs, 0–10 Vdc inputs, or 0–20 mA inputs.   |
|   |              | Linear               | 0–10 Vdc   |  |
|   |              | Temperature          | 10 kΩ thermistor   |  |
|   |              | Setpoint             | 189 Ω to 889 Ω   |  |
|   |              | Resistive            | 100 Ω to 100 kΩ  | Low impedance relay contacts recommended.  |
|   |              | Binary               | Open collector/dry contact   |  |
| Binary input (BI1 to BI3) <sup>(a)</sup>  | 3            |                      | 24 Vac detect  | The UC400 controller provides the 24 Vac required to drive the binary inputs when using the recommended connections.   |
|   |              |                      |  |  |
| Binary output (BO1 to BO3) <sup>(a)</sup> | 3            | <b>UC400:Relay</b>   | <ul style="list-style-type: none"> <li>• 2.88 A @24 Vac C pilot duty</li> <li>• Gen Purpose               <ul style="list-style-type: none"> <li>– 10 A max up 277 Vac</li> <li>– 10 A max up to 30 Vdc</li> </ul> </li> <li>• Motor Duty               <ul style="list-style-type: none"> <li>– 1/3 hp @ 125 VAC (7.5 A max)</li> <li>– 1/2 hp @ 277 VAC (7.5 A max)</li> </ul> </li> </ul> | Power needs to be wired to the binary output. All outputs are isolated from each other and from ground or power.<br><b>Note: Ranges given are per contact.</b>   |
|   | Other Ranges | <b>UC400–B:TRIAC</b> | 24 Vac Powered   |  |
| Binary output (BO4 to BO9) <sup>(a)</sup> | 6            | TRIAC                | <ul style="list-style-type: none"> <li>• <b>UC400:</b> 0.5 A max @24-277 Vac, resistive and pilot duty</li> <li>• <b>UC400–B:</b> 24 Vac Powered</li> </ul>  | Use for modulating TRIAC. User determines whether closing high side (providing voltage to the grounded load) or low side (providing ground to the power load).<br><b>Note: Ranges given are per contact and power comes from TRIAC SUPPLY circuit.</b> |



**Table 2. Connections (continued)**

| Connection   | Quantity  | Types         | Range                   | Notes   |
|--|-----------|---------------|-------------------------|---|
| Analog output/<br>binary input<br>(AO1/BI4 and<br>AO2/BI5) | 2         | Linear output | 0–20 mA                 | Each termination must be configured as either an analog output or binary input. |
|  |           | Linear output | 0–10 Vdc                |   |
|  |           | Binary input  | Dry contact             |   |
|  |           | PWM output    | 80 Hz signal @ 15 Vdc   |   |
| Pressure inputs<br>(PI1 and PI2)                           | 2         | 3-wire        | 0–5 in H <sub>2</sub> O | Used as a binary input for condensate on WSHP.                                  |
| <b>Overall Point Total</b>                                 | <b>23</b> |               |                         |   |

<sup>(a)</sup> Do Not mix Class 1 and Class 2 voltage wiring in an enclosure or on a controller without an approved barrier between the wiring.



# Additional Components

The UC400 Controller requires the use of additional components for monitoring and proper control of associated equipment. The use of specific components is dependent on the type of application.

*Note: Additional components are not included with the UC400 Controller.*

## Water, Discharge, and Outdoor Air Temperature Sensors

Temperature sensors must be Trane 10 kΩ (at 25°C) thermistors. Entering water and discharge air inputs can use a sealed temperature sensor (part numbers 4190 1100 and 4190 1133).

## Binary Input Switching Devices

Occupancy, condensate overflow, compressor protection, frost detection, and fan status inputs accept switching devices that may have normally open (NO) or normally closed (NC) dry contacts.

## Zone Temperature Sensors

The following table provides the sensor types and features supported by the UC400 Controller.

**Table 3. UC400 controller supported sensors and features**

| Sensor Type                                     | Features |  |        |                                 |      | Part Number | BAYSENS     | Global Parts |
|---|----------|--|--------|---------------------------------|------|-------------|-------------|--------------|
|   | Setpoint | Fan Control  | System | Occupancy                       | LEDs |             |             |              |
| Temperature Sensor                              | No       | No   | No     | No                              | No   | X1351152801 | BAYSENS077A | SEN01448     |
|   | No       |  |        | Yes                             |      | X1351153001 | BAYSENS073A | SEN01450     |
| Temperature Sensors w/ Fan Control              | Single   | <ul style="list-style-type: none"> <li>• Off</li> <li>• Auto</li> </ul>  | No     | Yes                             | No   | X1379084501 | N/A         | SEN01521     |
|   | Single   | <ul style="list-style-type: none"> <li>• Off</li> <li>• Auto</li> <li>• Low</li> <li>• High</li> </ul>                   |        | Yes                             |      | X1379084801 |             | SEN01524     |
|   | Single   | <ul style="list-style-type: none"> <li>• Off</li> <li>• Auto</li> <li>• Low</li> <li>• Medium</li> <li>• High</li> </ul> |        | Yes                             |      | X1379084201 |             | SEN01518     |
| Temperature Sensor w/LCD Display <sup>(a)</sup> | Single   | <ul style="list-style-type: none"> <li>• Off</li> <li>• Auto</li> <li>• Low</li> <li>• Medium</li> <li>• High</li> </ul> | No     | Can be configured for occupancy | No   | X1379088604 | N/A         | N/A          |

**Table 3. UC400 controller supported sensors and features (continued)**

| Sensor Type                        | Setpoint | Features   |        |           |      | Part Number                  | BAYSENS | Global Parts |
|------------------------------------|----------|--|--------|-----------|------|------------------------------|---------|--------------|
|                                    |          | Fan Control  | System | Occupancy | LEDs |                              |         |              |
| Wireless Zone Sensor w/Fan Control | Single   | <ul style="list-style-type: none"> <li>• Off</li> <li>• Auto</li> <li>• Low</li> <li>• Medium</li> <li>• High</li> </ul> | No     | Yes       | No   | X1379082201<br>(Sensor Only) | N/A     | N/A          |
|                                    |          |  |        |           |      | X1379082401<br>(Sensor Set)  |         |              |

<sup>(a)</sup> This sensor can be field configured to match the applicable unit controller options. Unit controller inputs for system status, fan, and service required are not available on this sensor. If replacing a BAYSENS031A or a BAYSENS035A sensor, and status indicators are required, replace with non-display sensor BAYSENS109A or BAYSENS110A.

## Valve and Damper Actuators

The 2-position analog and 3-wire floating point modulating actuators cannot exceed 12 VA draw at 24 Vac. For 2-position valves, use actuators with ON/OFF and spring actions that returns the valve to normally open (NO) or closed (NC), which are dependent on the desired default position. For modulating actuators, use actuators with or without a spring return, as required by the application.

## Zone Humidity Sensor

For measurement of relative humidity (RH), the UC400 Controller requires a zone humidity sensor with a 4–20 mA output, where 4 mA is 0% RH and 20 mA is 100% RH. The controller provides 24 Vdc to power the zone humidity sensor.

**Note:** As an option, the UC400 Controller can receive humidity from a Trane Air-fi™ Wireless Sensor with Humidity.

## Expansion Modules

The UC400 Controller can power a maximum of two (2) DC expansion modules (either the Tracer XM30 or Tracer XM32) without an additional power supply. It can support a maximum of 32 additional XM30, XM32 or XM70 hardware terminations when properly applying power.



# Typical Applications and Terminations

The following tables provide information about supported applications and termination wiring.

**Table 4. UC400 controller typical applications**

|           | Waterside Economizing | Hot Gas Reheat | Electric Heat | Boiler-less |
|-----------|-----------------------|----------------|---------------|-------------|
| Heat Pump | X                     |                |               |             |
|           |                       | X              |               |             |
|           |                       |                | X             |             |
|           |                       |                |               | X           |
|           | X                     | X              |               |             |
|           | X                     | X              | X             |             |
|           | X                     | X              |               | X           |
|           | X                     |                | X             |             |
|           | X                     |                |               | X           |
|           | Cooling Only          | X              |               |             |
|           |                       | X              |               |             |
|           |                       |                | X             |             |
| X         |                       | X              |               |             |
| X         |                       | X              | X             |             |
|           |                       | X              |               |             |

The following table 1 lists 1 or 2 compressor control with discrete 1– or 2–speed fans based on Trane GE units.

**Table 5. Factory programmed terminations for Trane GE units**

| Inputs/Outputs/Communication | UC400/UC400–BController Terminations | Factory Programmed Assumed Terminations            |
|------------------------------|--------------------------------------|--|
| Analog Inputs                | AI1                                  | Space Temperature Local                            |
|                              | AI2                                  | Space Temperature Setpoint Local                   |
|                              | AI3                                  | Local Fan Mode Switch                              |
|                              | AI4                                  | Discharge Air Temperature Sensor                   |
|                              | AI5                                  | Entering Water Temperature Sensor                  |
| Universal Inputs             | UI1                                  | Relative Humidity Sensor or CO <sub>2</sub> Sensor |
|                              | UI2                                  | Leaving Water Temperature                          |
| Binary Inputs                | BI1                                  | Occupancy  |
|                              | BI2                                  | Compressor 1 lockout status                        |
|                              | BI3                                  | Compressor 2 lockout status                        |
| Binary Outputs (Relay)       | BO1                                  | Fan High   |
|                              | BO2                                  | Waterside Economizer                               |
|                              | BO3                                  | Fan Low  |

**Table 5. Factory programmed terminations for Trane GE units (continued)**

| Inputs/Outputs/Communication | UC400/UC400-<br>BController<br>Terminations | Factory Programmed Assumed Terminations     |
|------------------------------|---|---|
| Binary Outputs (TRIAC)       | BO4   | Compressor 1 Command                        |
|                              | BO5   | Compressor 2 Command                        |
|                              | BO6   | Hot Gas Reheat/Electric Heat <sup>(a)</sup> |
|                              | BO7   | Reversing Valve                             |
|                              | BO8   | Isolation Valve/External Pump               |
|                              | BO9   | Outdoor Air Damper                          |
| Analog Outputs/Binary Inputs | AO1/BI4                                     | BI- Frost Detect (Coil Ice Protection)      |
|                              | AO2/BI5                                     | BI- Fan Status                              |
| Pressure Inputs              | PI1   | Condensate Overflow                         |
|                              | PI2   | Unused                                      |
| Service Button               |   | Test Mode Input                             |

<sup>(a)</sup> When Hot Gas Reheat and Electric Heat are present on the same WSHP, Electric Heat will be moved to BO1 on XM32.

The following table lists single compressor control with variable speed fan based on Trane EX/DX units.

**Table 6. Factory programmed terminations for single compressor control for Trane EX/DX units**

| Inputs/Outputs/Communication | UC400 Controller<br>Terminations | Factory Programmed Assumed Terminations  |
|------------------------------|----------------------------------|--|
| Analog Inputs                | AI1                              | Space Temperature Local  |
|                              | AI2                              | Space Temperature Setpoint Local   |
|                              | AI3                              | Local Fan Mode Switch  |
|                              | AI4                              | Discharge Air Temperature Sensor   |
|                              | AI5                              | Entering Water Temperature Sensor  |
| Universal Inputs             | UI1                              | Relative Humidity Sensor or CO <sub>2</sub> Sensor                                     |
|                              | UI2                              | Leaving Water Temperature  |
| Binary Inputs                | BI1                              | Occupancy Input  |
|                              | BI2                              | Compressor Protection Status (Monitors High/Low Pressure Cutout and Freeze Protection) |
|                              | BI3                              | Frost Detection  |
| Binary Outputs (Relay)       | BO1                              | Fan Enable   |
|                              | BO2                              | Water Economizer   |
|                              | BO3                              | No Connection  |
| Binary Outputs (TRIAC)       | BO4                              | Compressor Enable  |
|                              | BO5                              | EX Series — No Connection<br>DX Series — Compressor Step                               |
|                              | BO6                              | Hot Gas Reheat/Electric Heat <sup>(a)</sup>  |
|                              | BO7                              | Reversing Valve  |
|                              | BO8                              | Isolation Valve/External Pump  |
|                              | BO9                              | Outdoor Air Damper   |



## Typical Applications and Terminations

**Table 6. Factory programmed terminations for single compressor control for Trane EX/DX units (continued)**

| Inputs/Outputs/Communication | UC400 Controller Terminations | Factory Programmed Assumed Terminations |
|------------------------------|-------------------------------|---|
| Analog Outputs/Binary Inputs | AO1/BI4                       | AO- Variable Speed Fan Control          |
|                              | AO2/BI5                       | BI- Fan Status                          |
| Pressure Inputs              | PI1                           | Condensate Overflow                     |
|                              | PI2                           | No Connection                           |
| Service Button               |                               | Test Mode Input                         |

<sup>(a)</sup> When Hot Gas Reheat and Electric Heat are present on the same WSHP, Electric Heat will be moved to BO1 on XM32.

## Binary Inputs

The UC400 Controller has three (3) binary inputs and two (2) analog outputs/binary inputs (labeled BI1 through BI5), that can be configured as either analog outputs or binary inputs. Each binary input associates an input signal of 0 Vac with open contacts and 24 Vac with closed contacts. If changes are required, use the Tracer TU service tool to configure each of the inputs as normally open (NO) or normally closed (NC).

### BI1; Occupancy

Occupancy BI1 saves energy by spreading space temperature setpoints when the zone is unoccupied. Used as an occupancy input, BI1 has two (2) related functions:

- It changes the mode from occupied to occupied standby for controllers receiving a BAS-communicated occupancy request.
- It can be hard wired to a binary switch or time clock to determine the occupancy mode as either occupied or unoccupied for stand-alone controllers.

### BI2; Compressor 1 Protection Status

Factory programming monitors high and low pressure cutouts and compressor freeze protection of Compressor 1 on this input.

### BI3; Compressor 2 Protection Status

Factory programming monitors high and low pressure cutouts and compressor freeze protection of Compressor 2 on this input.

### BI3/BI4; Frost Detection

The frost detection sensor detects conditions that produce frost on the coil surface. When these conditions are present, the UC400 Controller detects the condition and generates a Frost Detection Input alarm.

### BI5; Fan Status

Fan Status BI5 provides feedback to the UC400 Controller regarding the operating status of the fan. If BI5 is wired to a fan status switch, and the input indicates that the fan is not operating when the controller has the fan controlled to ON, the controller generates a Low Primary Airflow Diagnostic.

## Analog Inputs

The UC400 Controller has seven (7) analog inputs.

### Ground Terminals

Use the  terminal as the common ground for all space temperature sensor analog inputs.

## **AI1; Space Temperature**

Space Temperature AI1 functions as the local (hard wired or wireless) space temperature input. The UC400 Controller receives the space temperature as a resistance signal from a 10 kΩ thermistor in a standard Trane space temperature sensor that is wired to analog input AI1. A space temperature value communicated by means of a BACnet link, can be used for controllers operating on a BAS. When both a hard wired and communicated space temperature value are present, and in service, the controller uses the communicated value.

If neither a hard wired nor a communicated space temperature value is present, the space temperature local and active points go into a fault state and generates an alarm. If neither the hard wired or communicated space temperature are valid, the equipment will shut down.

## **AI2; Space Temperature Local Setpoint**

Space Temperature Local Setpoint AI2 functions as the local (hard wired) space temperature setpoint input for applications utilizing a Trane space temperature sensor with a temperature setpoint thumbwheel or digital setpoint input. A setpoint value communicated by means of a BACnet link, can be used for controllers operating on a BAS. If both hard wired and communicated setpoint values are present, and in service, the UC400 Controller uses the communicated value.

In addition, the controller can be configured to use the local (hard wired) input value instead of the communicated value using the Tracer TU service tool. If neither a hard wired nor a communicated setpoint value is present, the controller uses the space temperature setpoint default analog value, which is configured using the Tracer TU service tool. If a local setpoint value is not valid or not present, the controller generates a Space Temperature Setpoint Local alarm.

## **AI3; Local Fan Mode Input**

Local Fan Mode Input AI3 functions as the local (hard wired) fan mode switch input for applications using the Trane space temperature sensor with a fan mode switch option. The various fan mode switch positions (OFF, LOW, MEDIUM, HIGH, AUTO) provide different resistances that are interpreted by the UC400 Controller.

**Note:** *The local fan speed switch can be disabled by taking out of service the multi-state point, supply fan speed local and setting the value for each to AUTO.*

A communicated fan mode request by means of the BACnet communications link, can be used for controllers operating on a BAS. If both hard wired and communicated fan mode values are present and in service, the UC400 Controller uses the communicated value. However, the controller can be configured to use the local (hard wired) input value instead of the communicated BAS value. The supply fan speed source (local or BAS) can be selected on the Tracer TU Setup Parameters page. If neither a hard wired nor a communicated fan mode value is present, the controller recognizes the fan mode value as AUTO and operates according to the default configuration. If a valid hard wired or communicated fan mode value is established, and then is no longer present, the controller generates a Supply Fan Speed Local alarm.

## **AI4; Discharge Air Temperature Sensor**

Discharge Air Temperature Sensor AI4 functions as the local discharge air temperature input.

The UC400 Controller receives the temperature as a resistance signal from a 10 kΩ thermistor wired to analog input AI4. The thermistor is typically located downstream from all unit heating and cooling coils at the unit discharge area. If a discharge air temperature value is invalid, or is not present, the controller generates a Discharge Air Temp Failure alarm.

## **AI5; Entering Water Temperature**

Entering Water Temperature AI5 functions as the local (hard wired) entering water temperature input. An entering water temperature communicated by means of the BACnet communications link (AV/4 Source Water Temperature BAS), can be used for UC400 Controller controllers operating on a BAS. If both hard wired and communicated entering water temperature values are present, and in service, the controller uses the communicated value. If a hard wired nor a communicated entering water temperature value is not valid, the controller generates an Entering Water Temperature Failure alarm.



## Typical Applications and Terminations

### Universal Inputs

The UC400 Controller has two (2) universal inputs.

#### UI1; Leaving Water Temperature

The UI1 analog input functions as the local (hard wired) leaving water temperature input. The unit can be configured to Alarm upon low leaving water temperatures.

#### UI2; Relative Humidity or CO<sub>2</sub> Sensor

**Relative Humidity:** the pre-configured unit requires a 4-20 mA analog input corresponding linearly to a 0%-100% relative humidity.

**CO<sub>2</sub> Sensor Input:** the pre-configured unit requires a 4-20 mA analog input corresponding linearly to 0-2000 ppm. Factory applications do not support CO<sub>2</sub> control. Instead, they only monitor the status of the sensor input.

### Pressure Inputs

The UC400 Controller controller has two (2) pressure inputs.

*Note: PI2 has no connection.*

#### PI1; Condensate Overflow

Condensate overflow prevents the condensate drain pan from overflowing and causing water damage to the building. If PI1 is wired to a condensate overflow switch, and the level of condensate reaches the trip point, the UC400 Controller detects the condition and generate a Condensate Overflow diagnostic.

### Wiring Requirements

The following table lists the required UC400 Controller inputs for proper minimum operation of all applications. The following wiring diagrams are separated to show first the UC400 and then the UC400-B.

Table 7. Required inputs

| Function   | Input source                  | Related information   |
|--|-------------------------------|---|
| 24 Vac Power   | Terminals: Ground, 24 Vac     | For more details on power wiring requirements, refer to the Tracer UC400 Controller Programmable Controller Installation, Operation, and Maintenance Manual, BAS-SVX20. |
| Space Temperature Local.   | Terminals: AI1, Ground        | AI1; Space Temperature  |
| Entering Water Temperature<br>(Required Only for Units With Auto-changeover. | Terminal: AI5 or communicated | AI5; Entering Water Temperature   |



### UC400 Wiring Diagrams

Figure 2. Common input/sensor connections (Trane EX units only)

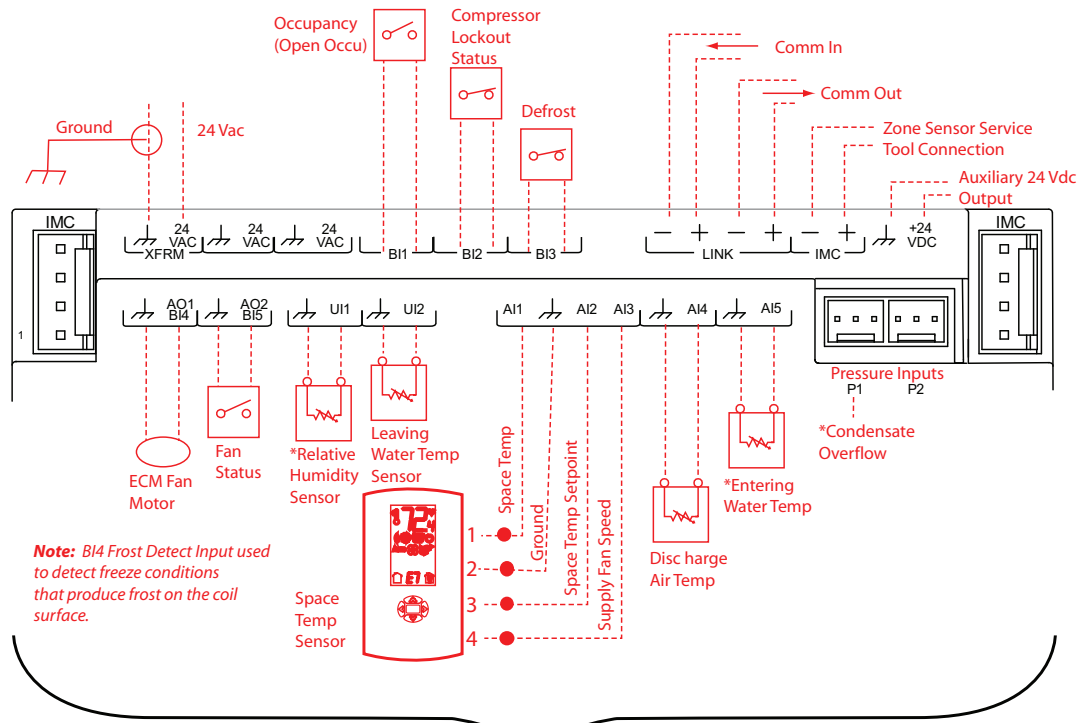

**Note:** BI4 Frost Detect Input used to detect freeze conditions that produce frost on the coil surface.

Two-Tier Terminal Connections

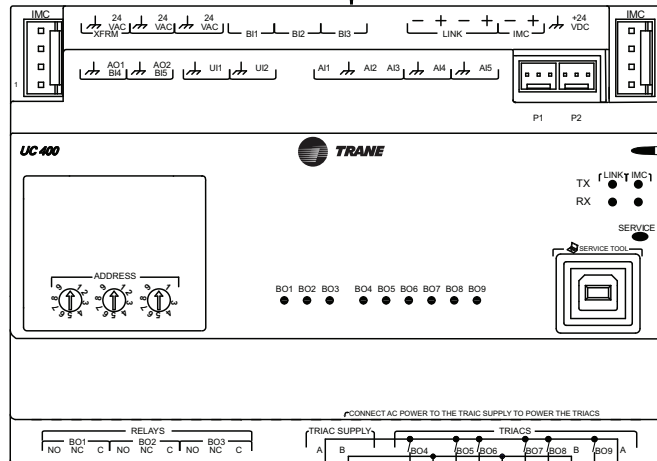

Asterisks (\*) Shown Above

- \*UI1 Relative Humidity Sensor can be used with dehumidifying unit instead of a BAS-communicated valve.
- \*AI5 Entering Water Temp Sensor used for auto-changeover units.
- \*P1 Condensate Overflow prevents the condensate drain from overflowing and causing water damage to the building.

Figure 3. 2-position ventilation economizer (Trane EX units only)

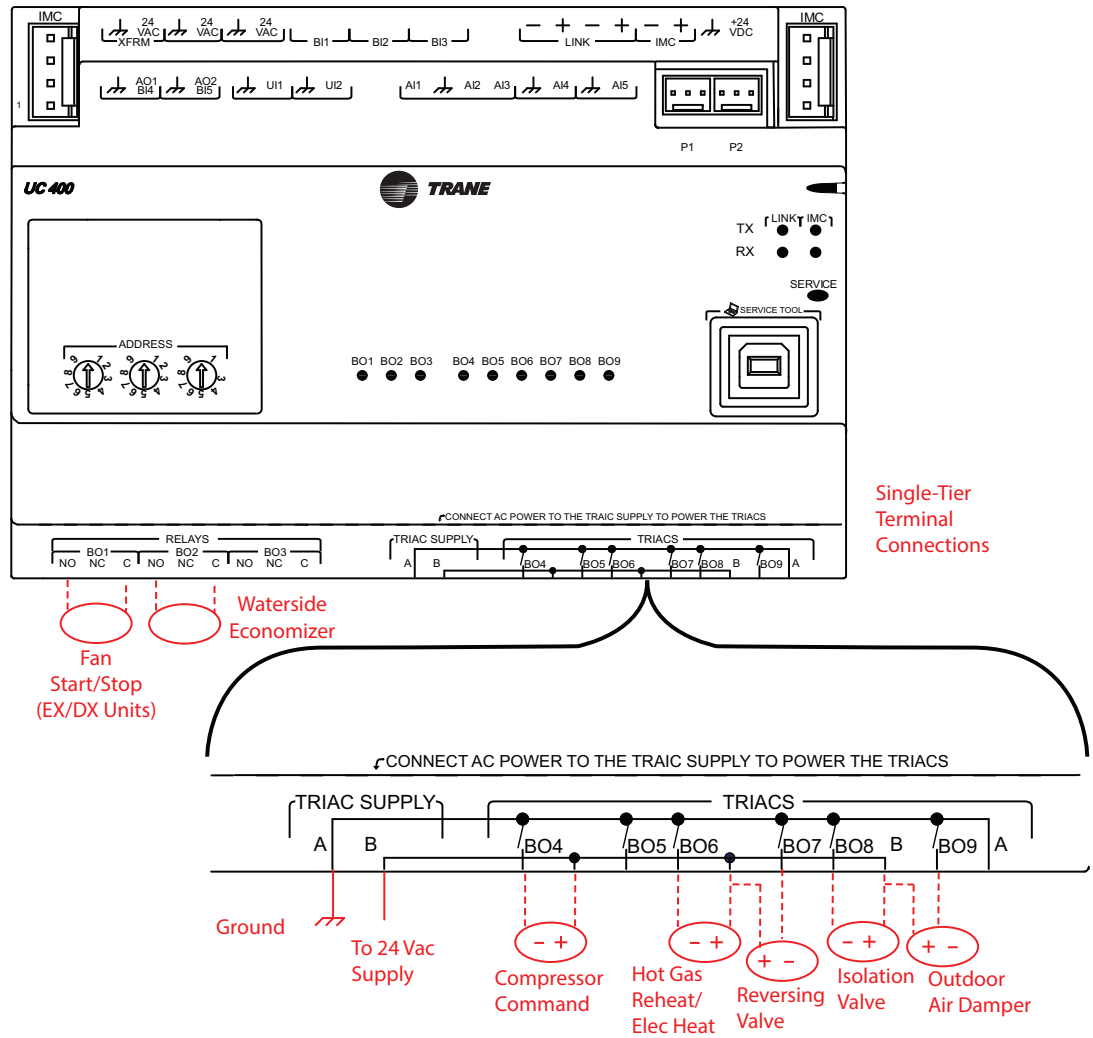

- NOTES:**
- BO5 is used for compressor stage 2 on DX units and BO4 is for compressor stage 1 on DX units.
  - When Hot Gas Reheat and Electric Heat are present on the same WSHP, Electric Heat will be moved to BO1 on XM32.

**Figure 4. Common input/sensor connections (GE units only)**

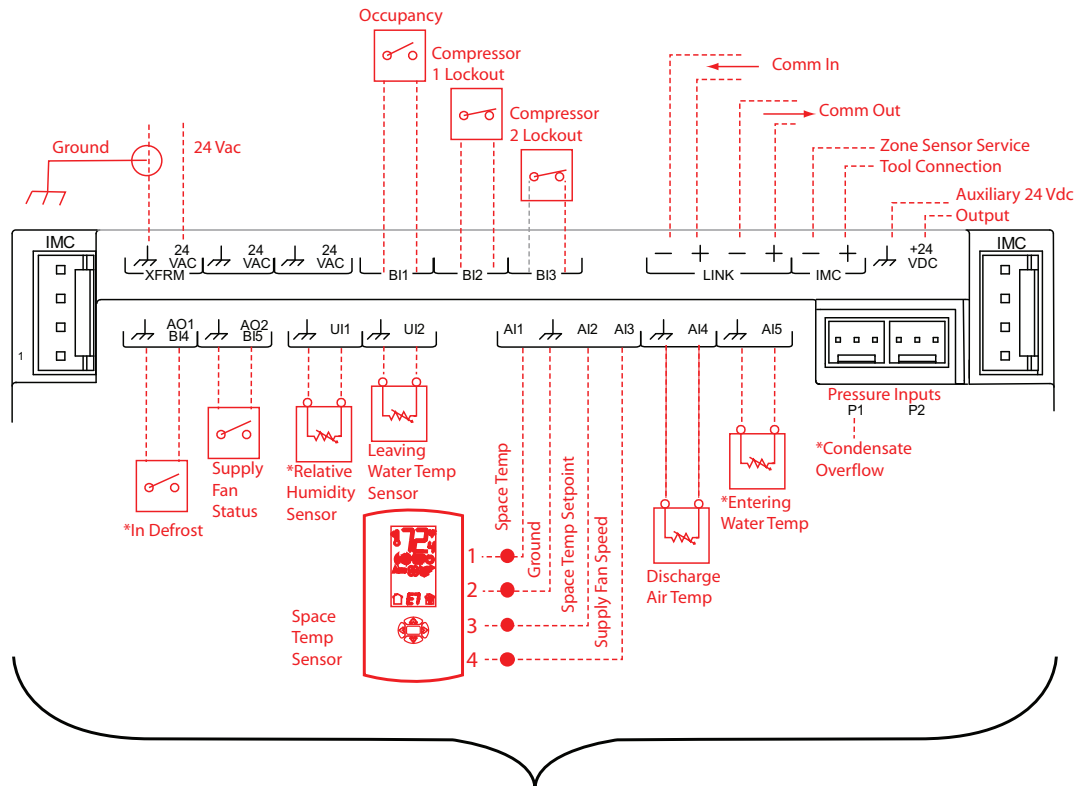

Two-Tier Terminal Connections

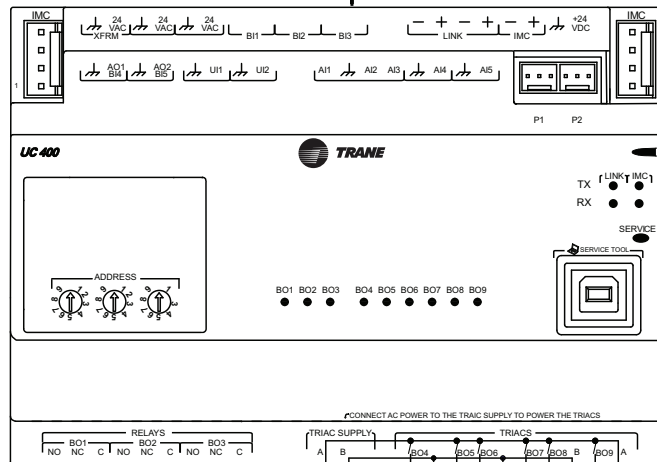

**Asterisks (\*) Shown Above**

- B14 Frost Detect Input used to detect freeze conditions that produce frost on the coil surface.
- UI1 Relative Humidity Sensor can be used with dehumidifying unit instead of a BAS-communicated valve.
- AI5 Entering Water Temp Sensor used for auto-changeover units.
- P1 Condensate Overflow prevents the condensate drain from overflowing and causing water damage to the building.

**Figure 5. 2-position ventilation economizer (GE units only)**

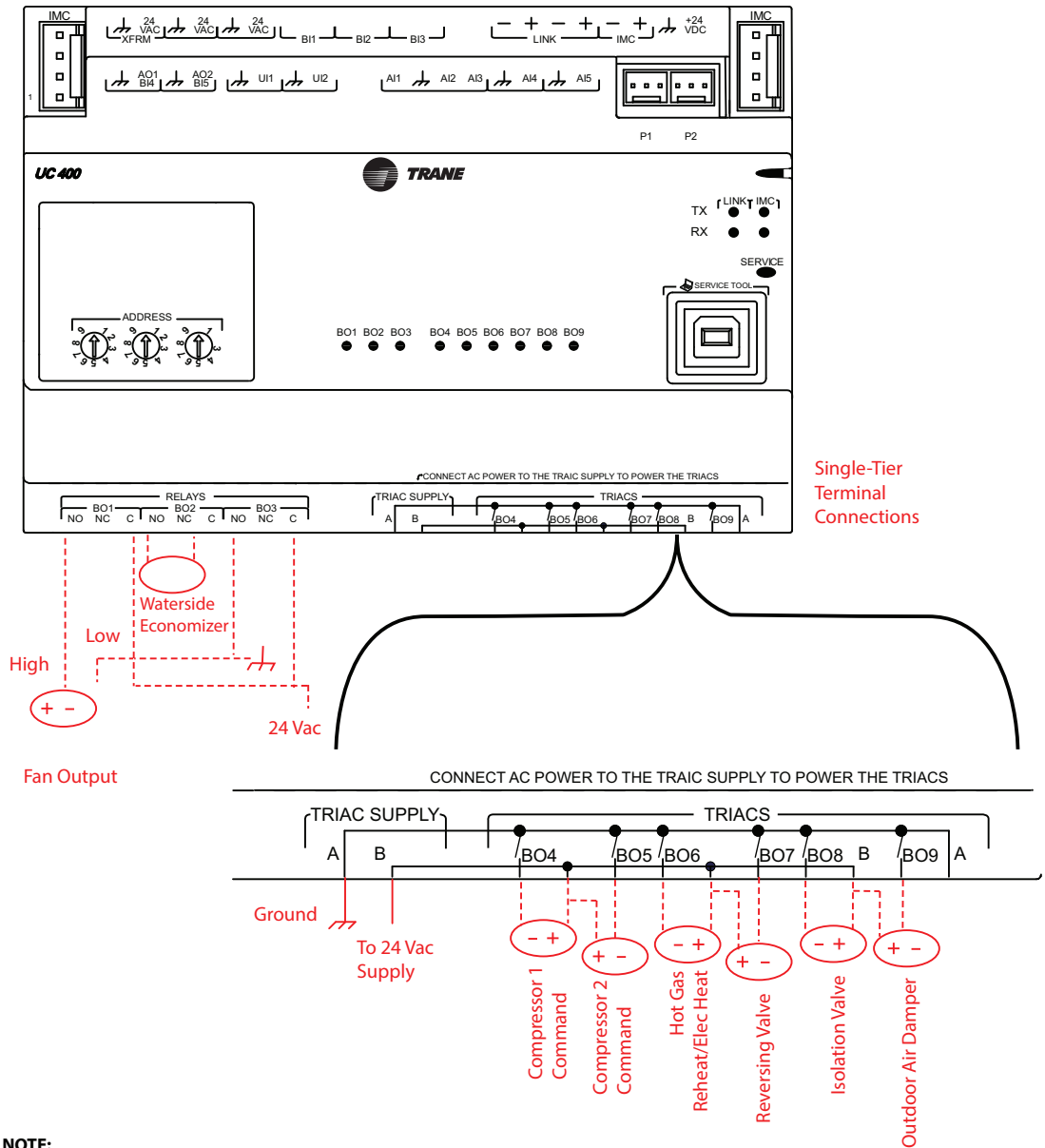

Figure 6. Variable speed supply fan

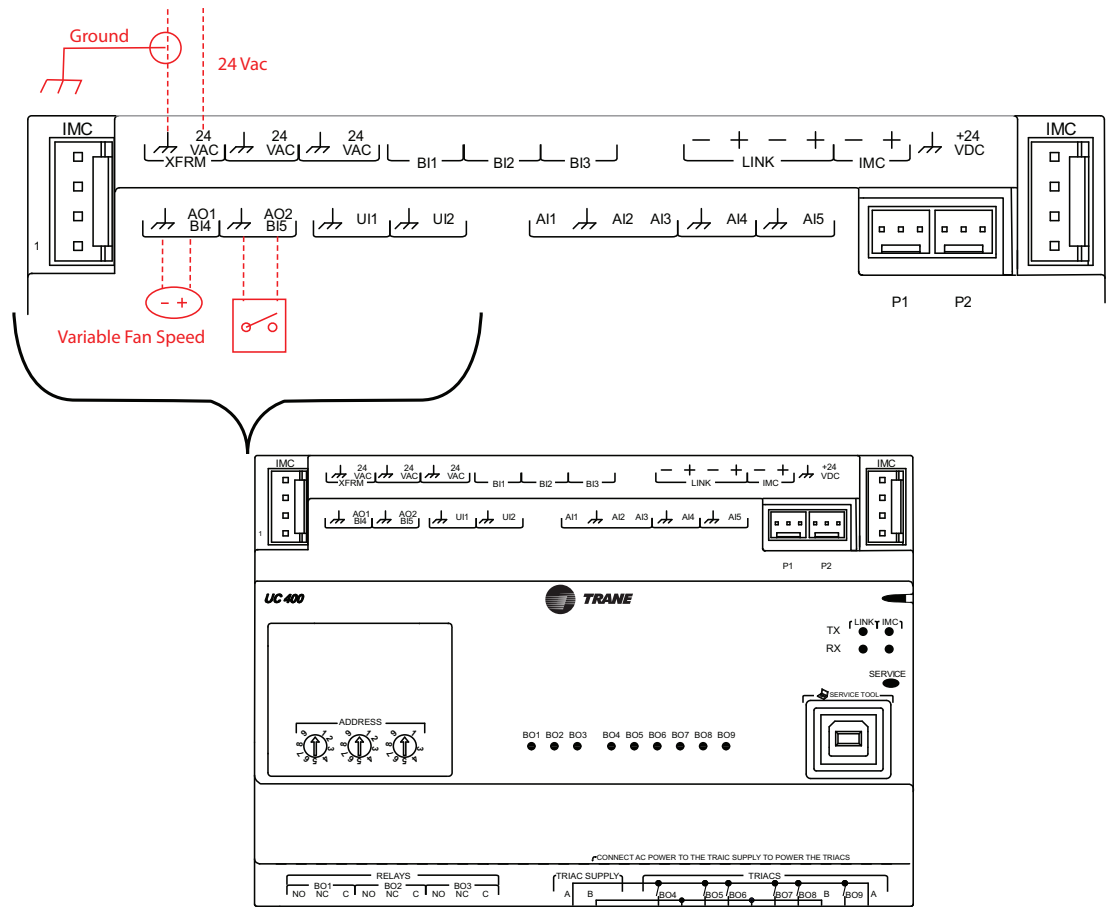
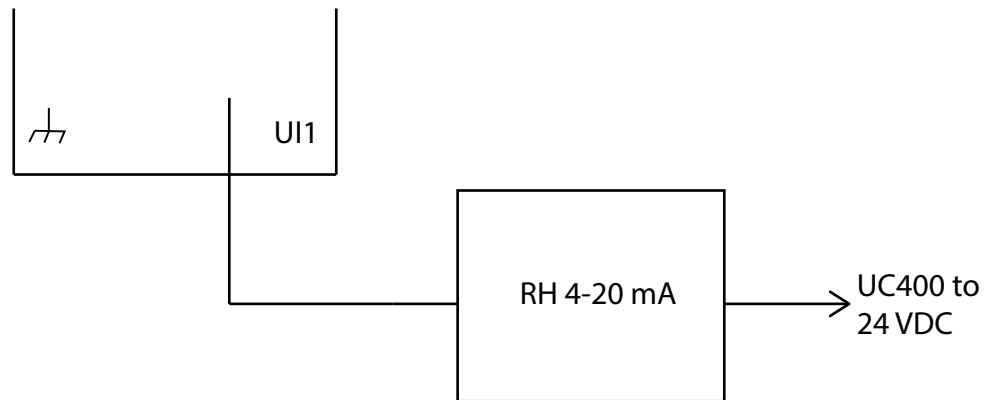
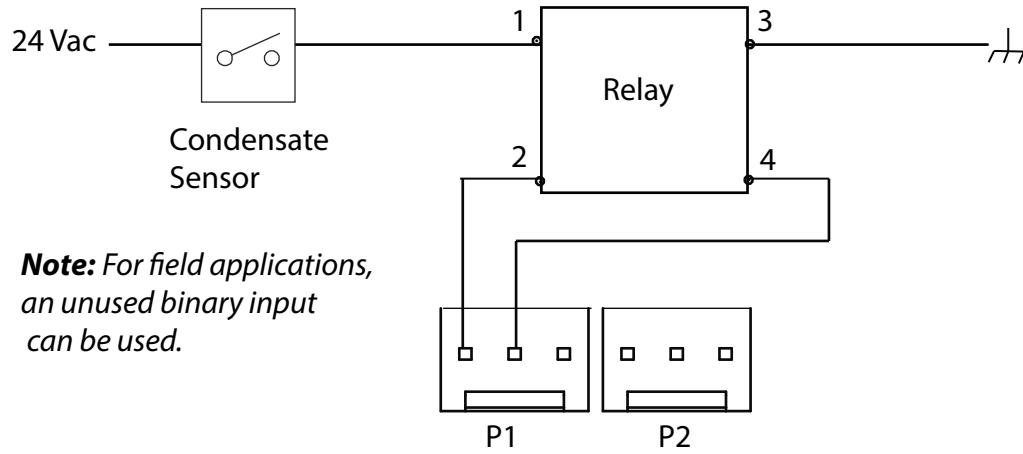

Figure 7. Relative humidity



# Typical Applications and Terminations

Figure 8. P1 condensate



## UC400-B Wiring Diagrams

Figure 9. Common input/sensor connections for GE units only

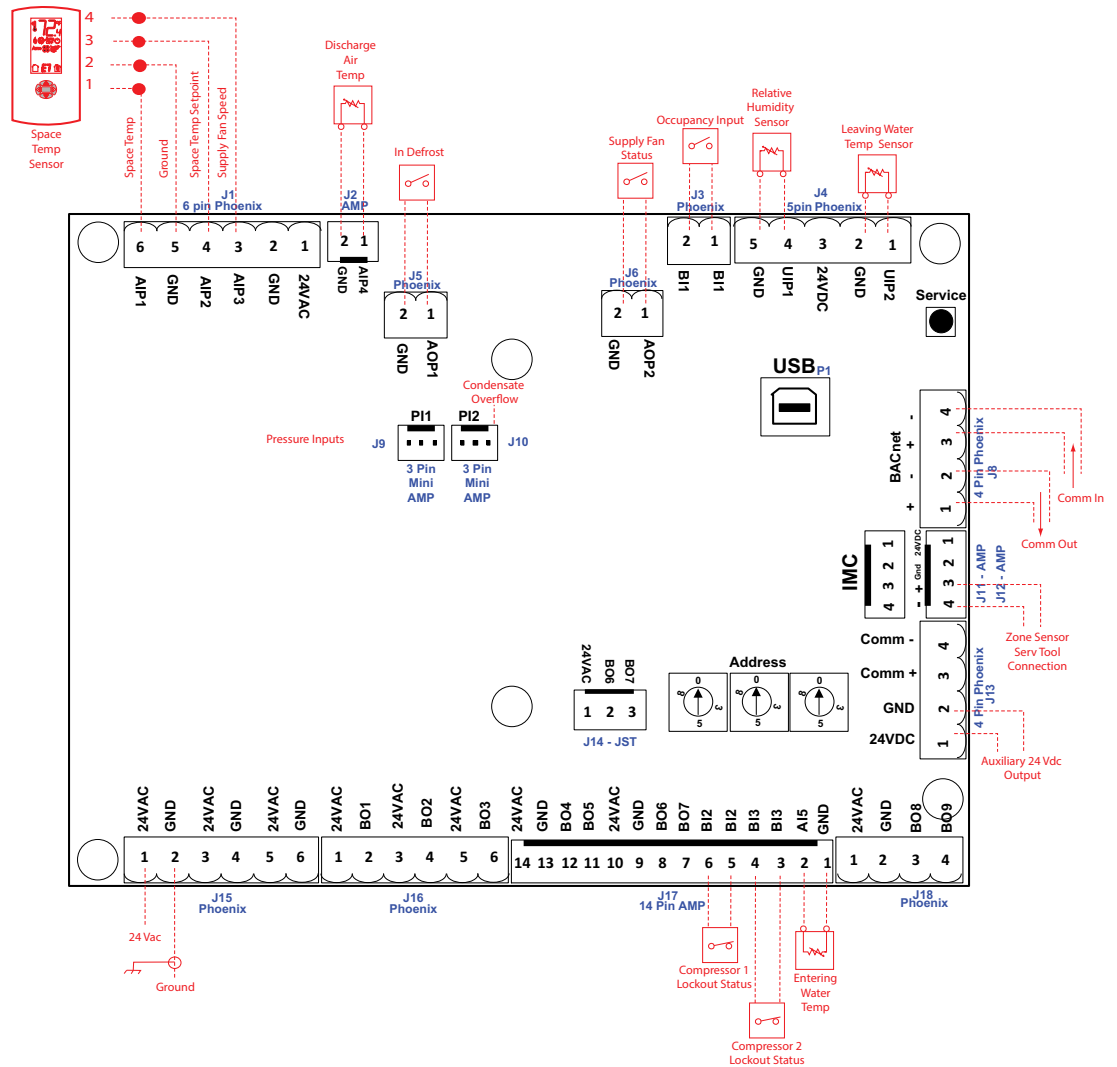

**Figure 10. 2-position ventilation economizer for Trane EX and DX units**

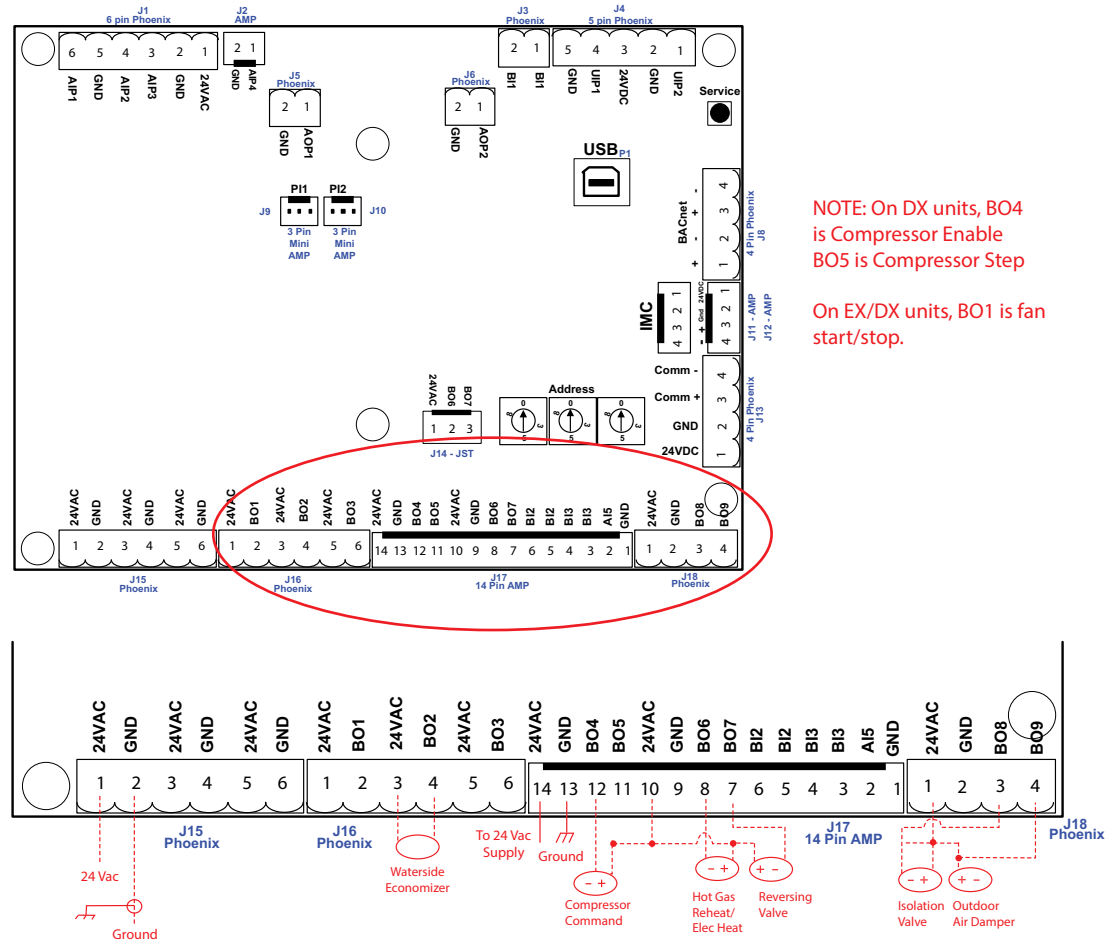

**Figure 11. Common input/sensor connections for EX and DX units**

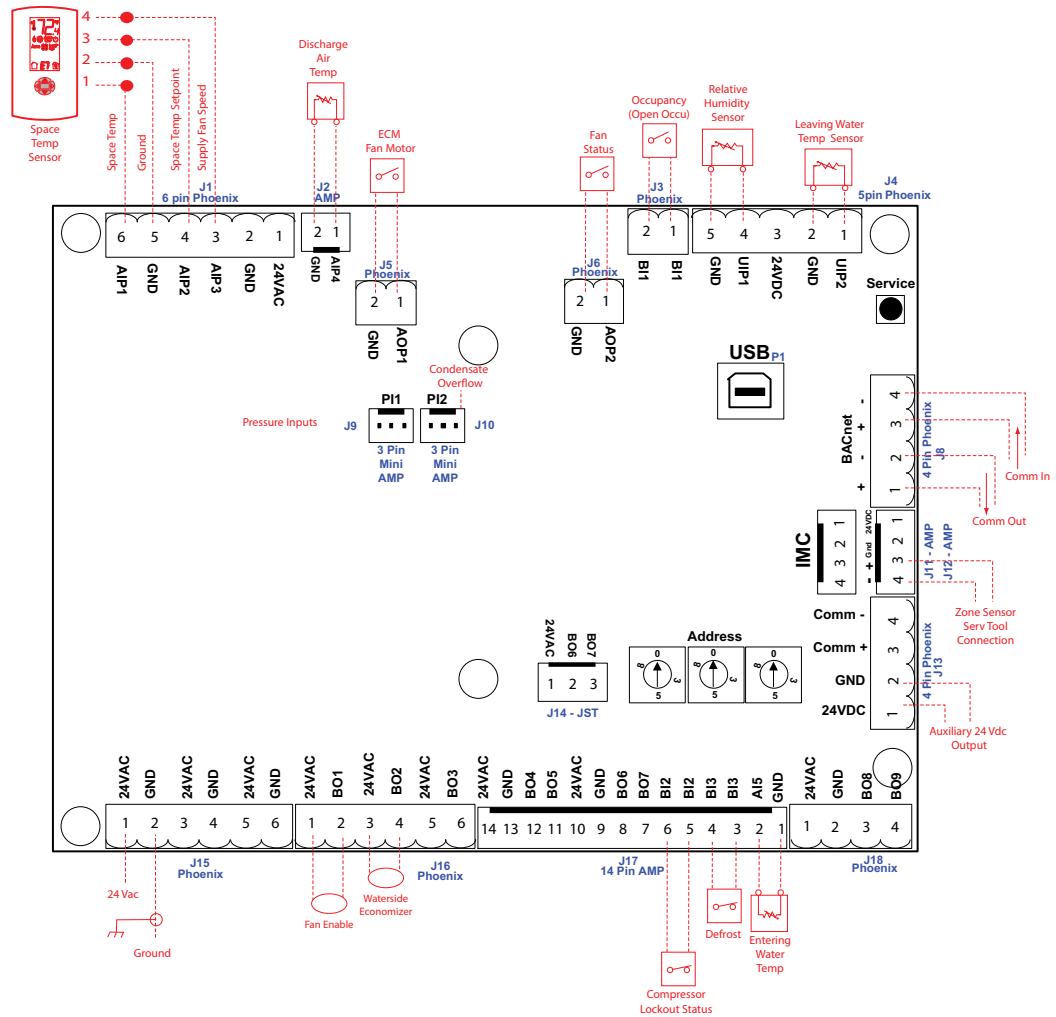



**Figure 12. 2-position ventilation economizer for GE units only**

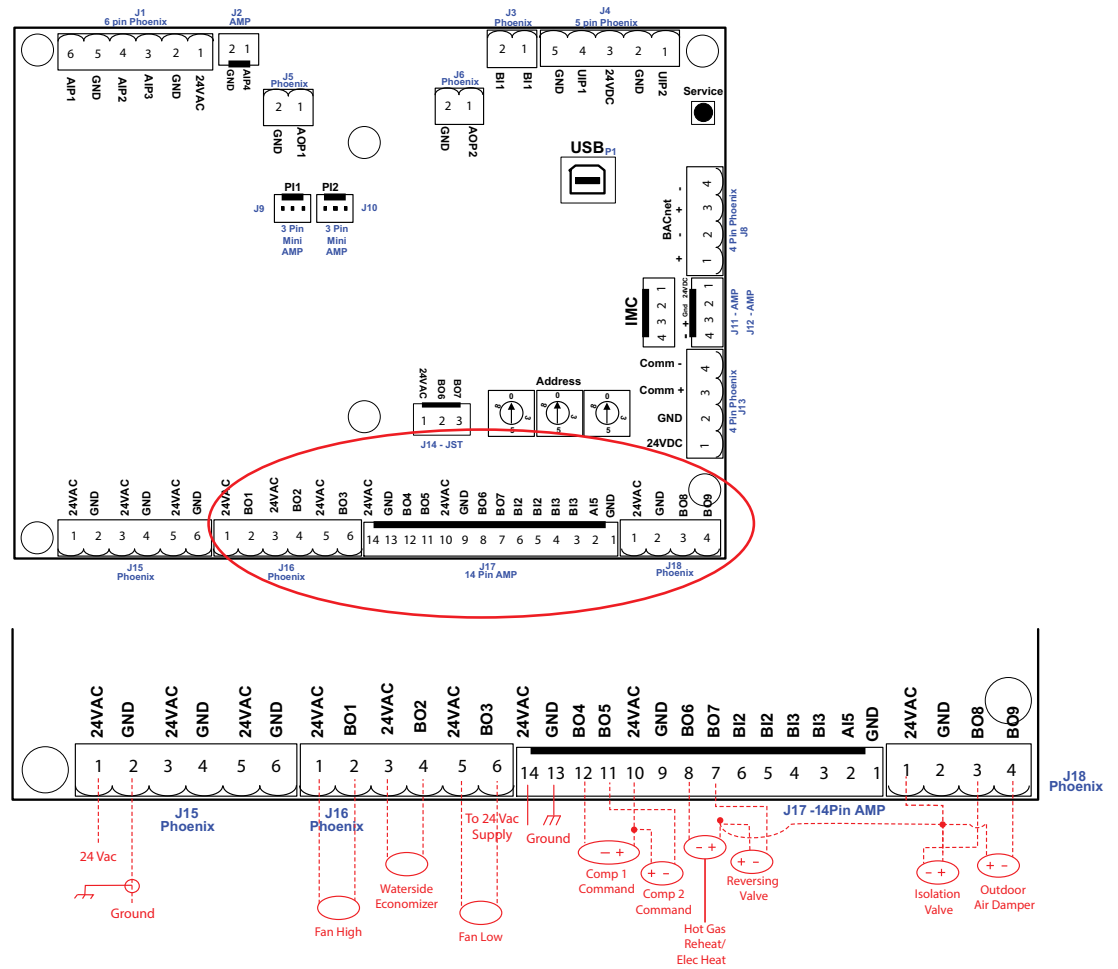
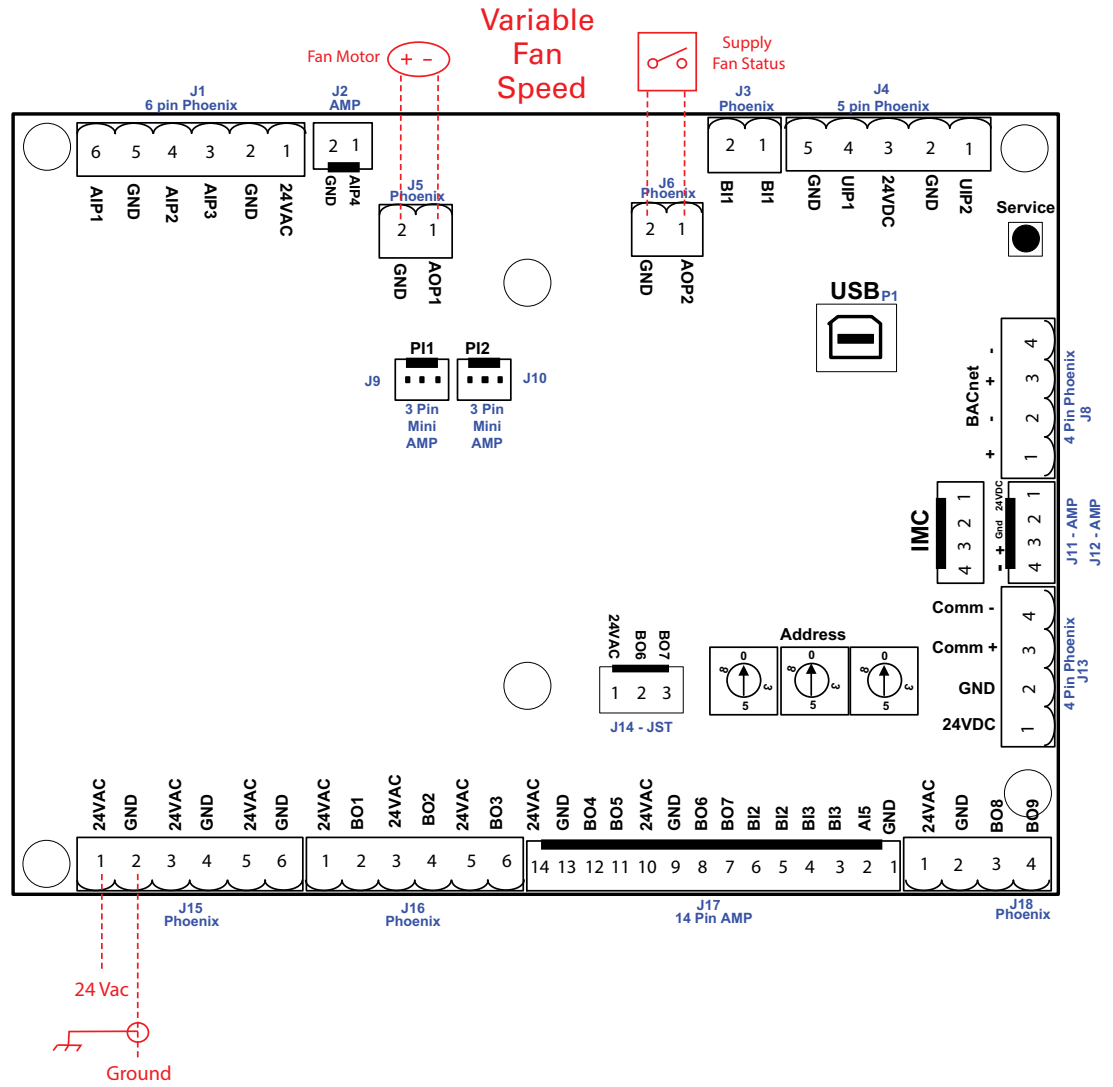

Figure 13. Variable speed supply fan





# Wiring Installation

The Tracer UC400 Controller can be installed on a BACnet MS/TP link, or with the Trane® Wireless Communication Interface (WCI), which enables wireless communication. All wiring must comply with the National Electrical Code (NEC™) and local electrical codes.

## Connecting Wires to Terminals

1. Strip the wires to expose approximately a 0.28 inch of bare wire.
2. Insert the stripped wire end into the terminal connector.
3. Tighten the terminal screw 0.5 to 0.6 N-m (71 to 85 ozf-in or 4.4 to 5.3 lbf-in.).
4. Tug on the connected wires after tightening down the terminal screws to ensure all wires are secure.

## BACnet MS/TP Link

The UC400 Controller rotary address dials serve one or two purposes (depending upon the network) in that they are always used for the MAC Address, which is sometimes all or part of the BACnet Device ID.

### MAC Address

The MAC Address is required by the RS-485 communication protocol on which BACnet operates. A UC400 Controller can use a MAC Address from 001 to 120. Each device on the link must have a unique MAC Address/Device ID. The controller rotary addresses should be sequentially set, with no gaps in the numbering, starting with 001 on each link (for example 001, 002, 003, 004 and so on). A duplicate address or a 000 address setting interrupts communications and cause the Tracer SC device installation process to fail.

### BACnet Device ID

The BACnet Device ID is required by the BACnet network. Each device must have a unique number from 001 to 4094302.

## BACnet Networks, With or Without Tracer SC Controller

### Without a Tracer SC Controller

On BACnet networks without a Tracer SC system controller, the Device ID can be assigned by two methods:

- It can be the same number as the MAC Address, determined by the rotary address dials on the UC400 Controller. For example, if the rotary address dials are set to 042, both the MAC Address and the BACnet Device ID are 042.
- It can be soft set by using the Tracer TU service tool. If the BACnet Device ID is set using the Tracer TU service tool, the rotary address dials will only affect the MAC Address and will not affect the BACnet Device ID.

### With a Tracer SC Controller

On BACnet networks with a Tracer SC system controller, the Device ID for the UC400 Controller is always soft set by the system controller (refer to the following table).

**Note:** *The BACnet Device ID is displayed as the Software Device ID on the Tracer TU Controller Settings page in the Protocol group.*

**Table 8. BACnet device ID calculations**

|  |   |   |   |   |   |   |   |
|--|---|---|---|---|---|---|---|
| Tracer SC Rotary Switch Value (21)     | 0 | 2 | 1 |   |   |   |   |
| Tracer SC BACnet MS/TP Link Number (1) |   |   |   | 1 |   |   |   |
| Unit Controller MAC Address (38)       |   |   |   |   | 0 | 3 | 8 |
| BACnet Device ID: 211038               | 0 | 2 | 1 | 1 | 0 | 3 | 8 |

## BACnet MS/TP Link Wiring

The wire must be low-capacitance, 18-gauge, stranded, tinned-copper, shielded, twisted-pair. The illustration below shows an example of BACnet link wiring with multiple UC400 Controller controllers.

**Figure 14. BACnet MS/TP link wiring for UC400 and UC400-B**

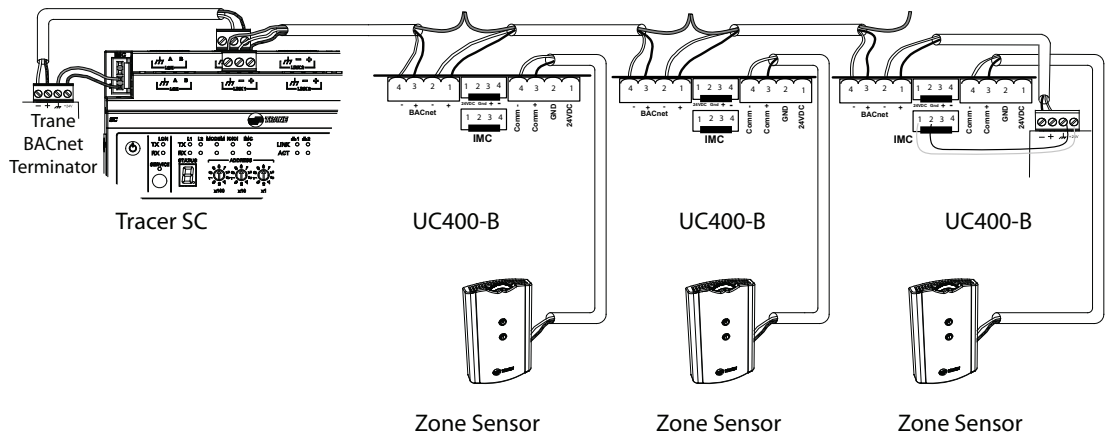
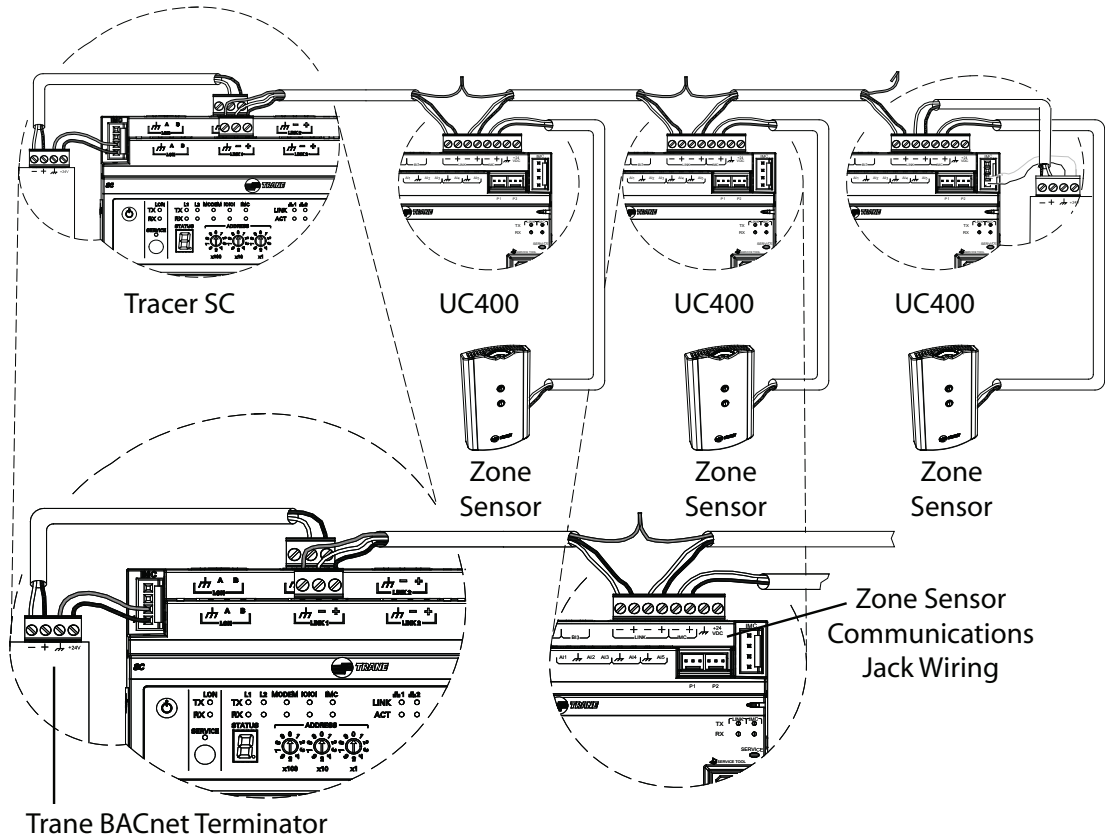

## Power Supply

Read the following Warnings, Cautions, and Notices before proceeding.

### **⚠ WARNING**

#### **Hazardous Voltage!**

Failure to disconnect power before servicing could result in death or serious injury. Disconnect all electric power, including remote disconnects before servicing. Follow proper lockout/tagout procedures to ensure the power can not be inadvertently energized. Verify that no power is present with a voltmeter.

### **NOTICE**

#### **Equipment Damage!**

Sharing 24 Vac power between controllers could result in equipment damage.

**Important:** After installation, ensure that the 24 Vac transformer is grounded through the controller. Measure the voltage between chassis ground and any ground terminal on the UC400 Controller. Expected measurement : Vac  $\leq 4.0$  V

A separate transformer is recommended for each UC400 Controller. The line input to the transformer must be equipped with a circuit breaker sized to handle the maximum transformer line current. If a single transformer is shared by multiple UC400 Controllers:

- The transformer must have sufficient capacity.
- Polarity must be maintained for every controller powered by the transformer.

**Important:** If the polarity is inadvertently reversed between two controllers powered by the same transformer, a difference of 24 Vac occurs between the grounds of each controller, which can result in:

- Partial or full loss of communication on the entire BACnet MS/TP link.
- Improper function of the UC400 Controller outputs.
- Damage to the transformer or a blown transformer fuse.

## Transformer Recommendations

A 24 Vac power supply must be used for proper operation of the binary inputs, which requires 24 Vac detection. In addition, the spare 24 Vac outputs can be used to power relays and TRIACS:

- AC transformer requirements:

**Note:** The transformer must be sized to provide adequate power to the controller (12 VA) and outputs (maximum 12 VA per binary output).

- UL listed, Class 2 power transformer.
  - 24 Vac  $\pm 15\%$ , device max load 24 VA.
- CE-compliant installations: The transformer must be CE marked and SELV compliant per IEC standards.

## Wiring Requirements

Install the power supply circuit in accordance with the following guidelines to ensure proper operation of the UC400 Controller:

- A dedicated power circuit disconnect switch must be near the controller, easily accessible by the operator, and marked as the disconnecting device for the controller.
- 18 AWG (0.823 mm<sup>2</sup>) copper wire is recommended for the circuit between the transformer and the controller.

**Important:** The controller must receive AC power from a dedicated power circuit. Failure to comply may cause the controller to malfunction. Do Not run AC power wires in the same wire bundle with input/output wires. Failure to comply may cause the controller to malfunction due to electrical noise.

## Connecting 24 Vac Secondary Wires

1. Connect the 24 Vac secondary wires from the transformer to the 24 Vac and terminals on the UC400 Controller (refer to the illustration below). Perform one of the following methods to ensure the controller is adequately grounded:
  - a. Connect a grounding pigtail at some point along the secondary wire that runs between the controller terminal and the transformer.
  - b. Ground one of the terminals on the controller to the enclosure (if the enclosure is adequately grounded) or to an alternate earth ground.
2. Connect the 24 Vac secondary wires from the transformer to the 24 Vac and ground terminals on the controller as shown below.

**Figure 15. Connecting 24 Vac secondary wires for UC400 and UC400-B**

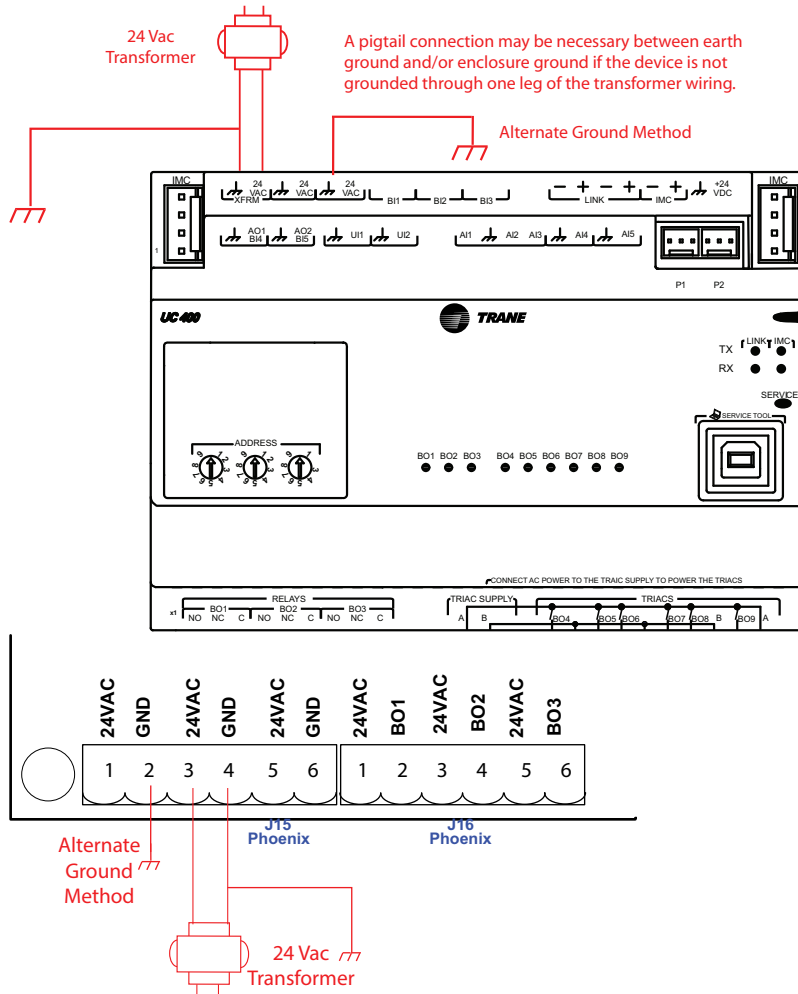

3. Ground the unit using one of the following methods:

**Note:** The UC400-B is grounded through mounting screws so external grounded is not required.

- a. Connect a grounding pigtail at some point along the secondary wire that runs between the controller ground terminal and the transformer.

- b. If the enclosure is adequately grounded, then ground one of the ground terminals on the controller to the enclosure or to an alternate earth ground.

## **Power On Check**

1. Verify that the 24 Vac connector and the chassis ground are properly wired.
2. Remove the lockout/tagout from the line voltage power to the electrical cabinet.
3. Energize the transformer to apply power to the UC400 Controller.
4. Observe the controller when power is applied to verify the power check sequence performs as follows:
  - a. The power LED is lit red for one (1) second.
  - b. The power LED is lit green if:
    - The sequencing above is completed as described and the controller is properly booted and ready to receive the application code.
  - c. The power LED flashes red indicating a fault condition exists.

# LED Description, Activities, and Troubleshooting

LEDs are used to provide controller serviceability. The UC400/UC400-B has the following LEDs located on the front. Refer to the legend in the second image in the figure below for LED placements.

- Marquee LED.
- Communication status LEDs and IMC status LEDs.
- Service button LED.
- Three (3) binary output relay and nine (9) TRIAC status LEDs.

**Figure 16. LEDs for UC400 and UC400-B**

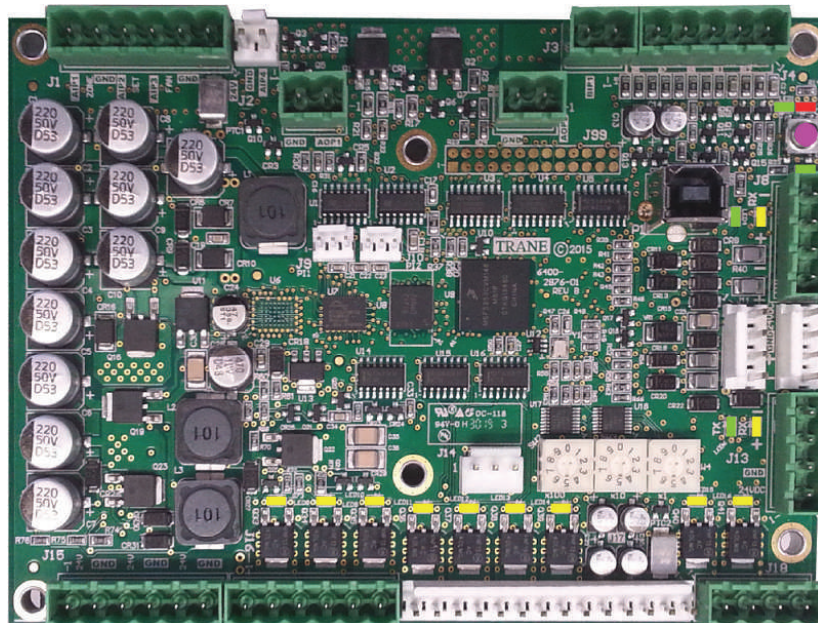
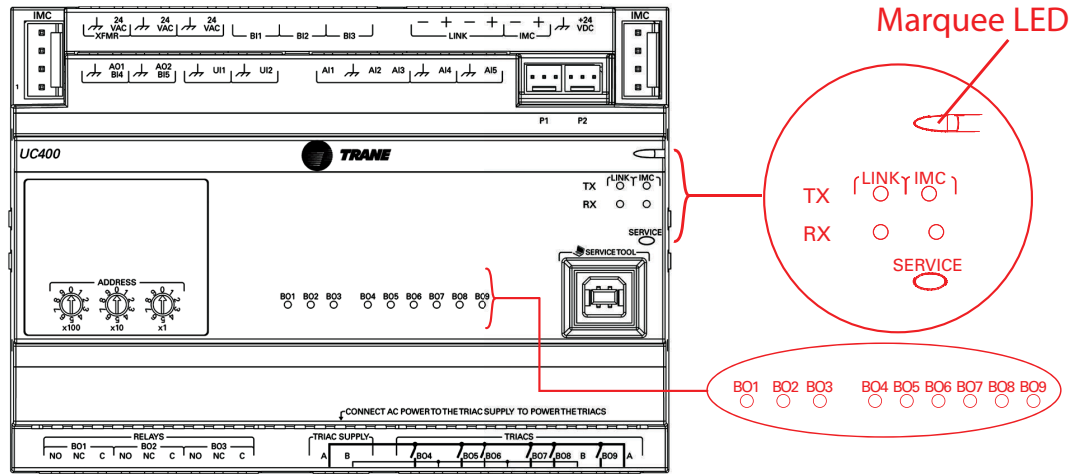

**LEGEND**

From the top right-hand side down:

- LED1 Green Status LED
- LED2 Red Status LED
- Service Button Magenta
- LED3 Green Service LED
- LED4 Green BACnet TX
- LED5 Yellow BACnet RX
- LED6 Green IMC TX
- LED7 Yellow IMC RX

From the bottom, left to right:

- LED8 Yellow BOP1
- LED9 Yellow BOP2
- LED10 Yellow BOP3
- LED11 Yellow BOP4
- LED12 Yellow BOP5
- LED13 Yellow BOP6
- LED14 Yellow BOP7
- LED15 Yellow BOP8
- LED16 Yellow BOP9

There are 15 LEDs on the front of the UC400 controller. The following table provides a description of LED activities, an indication or troubleshooting tip for each, and any relative notes.



## LED Description, Activities, and Troubleshooting

**Table 9. UC400 LEDs**

| LED Description | Activities   | Indication and Troubleshooting Tips   | Notes  |
|-----------------|--|---|--|
| Marquee LED     | Shows solid green when the unit is powered and no alarm exists.                      | Indicates normal operation.   | When powering the UC400 and expansion module, the Marquee LED will blink RED, blink GREEN (indicating activated and the controller/expansion module are communicating), and then stay Green Continuously (indicating normal power operation).  |
|                 | Shows blinking green during a device reset or firmware download.                     | Indicates normal operation.   |  |
|                 | Shows solid red when the unit is powered, but represents low power or a malfunction. | If low power; could be under voltage or the microprocessor has malfunction.<br><br>If malfunction; un-power and then re-power unit to bring the unit back up to normal operation.                               |  |
|                 | Shows blinking red when an alarm or fault exists                                     | An alarm or fault condition will occur if the value for a given point is invalid or outside the configured limits for the point. Alarm and fault conditions vary, and they can be configured by the programmer. |  |
|                 | LED not lit  | Indicates power is OFF or there is a malfunction.<br><br>OFF or malfunction; cycle the power.   |  |
| Link and IMC    | TX blinks green.   | Blinks at the data transfer rate when the unit transfers data to other devices on the link.   | TX LED: Regardless of connectivity or not, this LED will constantly blink as it continually looks for devices to communicate to.<br><br>LED not lit: Determine if, for example, a Tracer SC or BACnet device is trying to talk to the controller or if it is capable of talking to the controller. Also determine if the communication status shows down all of the time. In addition, check polarity and baud rate. |
|                 | RX blinks yellow.  | Blinks at the data transfer rate when the unit transfers data to other devices on the link.<br><br>ON solid yellow; indicates there is reverse polarity.  |  |
|                 | LED not lit.   | Indicates that the controller is not detecting communication.<br><br>Not lit; cycle the power to reestablish communication.   |  |
| Service         | Shows solid green when the LED has been pressed.                                     | Indicates controller is operating normally.   | When the UC400 is placed into boot mode, the system will not run any applications such as trending, scheduling, and TGP2 runtime. The controller is placed into boot mode if the service pin is held in when power is applied. In boot mode, the controller is non-operational and is waiting for a new main application to be downloaded.   |
|                 | LED not lit.   |   |  |

## LED Description, Activities, and Troubleshooting

**Table 9. UC400 LEDs (continued)**

| LED Description        | Activities          | Indication and Troubleshooting Tips   | Notes  |
|------------------------|---------------------|---|--|
| Binary B01 through B09 | Shows solid yellow. | <p>Indicates a corresponding binary output has been commanded ON.</p> <p>Relay coil; indicates that a command has been made to energize.</p> <p>TRIAC; indicates that a command has been made to turn ON.</p> | <p>If the user is currently powering the UC400 from a USB port, the Led lights will turn ON. However, the binary outputs will not be activated.</p> <p>Commanded ON; As an example of commanded ON, a command could be a manual command such as an override or a command could be from TGP2 based on a list of conditions that are met telling these outputs to turn ON.</p> |
|                        | LED not lit.        | <p>Indicates that a relay output is de-energized or no power to the board.</p> <p>Not lit; cycle power to reestablish communication.</p>  |  |



# Sequence of Operation

The UC400 Controller operates to maintain the space temperature setpoint.

## Power-up Sequence

1. The following sequence occurs when 24 Vac power is initially applied to the UC400 Controller:
  - The Power Marquee LED turns on as red, then
  - Flashes green, and then
  - Stays lit as constant green.
2. All outputs are controlled OFF.
3. The controller reads all input local values to determine initial values.
4. The random start timer begins.
5. The random start timer expires.
6. Normal operation begins, assuming there are no generated diagnostics. If any points are in fault or alarm mode, the Power Marquee LED flashes red.

**Important:** *Flashing red does not indicate that the UC400 Controller fails to operate. Instead, the point(s) that are in fault or alarm mode should be checked to determine if the status of the point(s) is acceptable to allow equipment operation.*

## Random Start

Random start prevents all units in a building from energizing at the same time. The random start timer delays the fan and any heating or cooling startup from 5 to 30 seconds.

## Occupancy Modes

Occupancy modes can be controlled by the following methods:

- The state of the local (hard wired) occupancy binary input BI1.
- A timed override request from a Trane zone sensor.
- A communicated signal from either a Tracer SC or BAS.

A communicated request, from either a Tracer SC or BAS, takes precedence over local requests. If a communicated occupancy request has been established and is no longer present, the controller reverts to the default (occupied) occupancy mode after 15 minutes (if no hard wired occupancy request exists). The UC400 Controller includes the following occupancy modes:

- Occupied
- Unoccupied
- Occupied Standby
- Occupied Bypass

**Table 10. Occupancy modes**

| Occupancy Request (MV/6) | Occupancy Input (B/1) | TOV Initiated    | Resultant Occupancy–Occupancy Status (MV/7) |
|--------------------------|-----------------------|------------------|---|
| Occupied                 | Occupied              | X <sup>(a)</sup> | Occupied                                    |
|                          | Unoccupied            | Yes              | Occupied Standby                            |
|                          |                       | No               | Bypass                                      |
| Occupied Bypass          | Occupied              | X                | Occupied                                    |
|                          | Unoccupied            | No               | Occupied Standby                            |
|                          |                       | Yes              | Occupied Bypass                             |

**Table 10. Occupancy modes (continued)**

| Occupancy Request (MV/6) | Occupancy Input (B/1) | TOV Initiated | Resultant Occupancy–Occupancy Status (MV/7) |
|--------------------------|-----------------------|---------------|---|
| Unoccupied               | X                     | No            | Unoccupied                                  |
|                          |                       | Yes           | Occupied Bypass                             |
| Occupied Standby         | X                     | No            | Occupied Standby                            |
|                          |                       | Yes           | Occupied Bypass                             |
| Auto                     | Occupied              | X             | Occupied                                    |
|                          | Unoccupied            | No            | Unoccupied                                  |
|                          |                       | Yes           | Occupied Bypass                             |
| Out of Service = True    | Occupied              | X             | Occupied                                    |
|                          | Unoccupied            | No            | Unoccupied                                  |
|                          |                       | Yes           | Occupied Bypass                             |

<sup>(a)</sup> Not recognized by the point as important.

## Occupied Mode

In Occupied Mode, the UC400 Controller maintains the space temperature based on the occupied space temperature setpoint  $\pm$  occupied offset. When occupied, the fan can be configured to operate continuously (default) or cycle ON/OFF with demand, based on BV/1 (Supply Fan Configuration Command). The controller uses the occupied mode as a default mode when other forms of occupancy requests are not present. The outdoor air damper, if present, closes when the fan is OFF. The temperature setpoints can be local (hard wired), communicated, or stored default values (configured using the Tracer TU service tool).

## Unoccupied Mode

In unoccupied mode, the UC400 Controller attempts to maintain the space temperature based on the unoccupied heating or cooling setpoint. The fan cycles between HIGH speed and OFF. In addition, the outdoor air damper remains closed, unless economizing. The controller always uses the stored default setpoint values (configured using the Tracer TU service tool), regardless of the presence of a hard wired or communicated setpoint value.

## Occupied Standby Mode

The UC400 Controller is placed in occupied standby mode only when a communicated occupied request is combined with an unoccupied request from occupancy binary input B11. In occupied standby mode, the controller maintains the space temperature based on the occupied space temperature setpoint,  $\pm$  the occupied standby offset (default 7.5°F). Because the occupied standby setpoints have a wider spread than the standard occupied setpoints and the outdoor air damper is closed, the occupied standby mode reduces the demand for heating and cooling the space. The fan runs as configured for occupied mode.

## Occupied Bypass Mode

The UC400 Controller is placed in occupied bypass mode when:

- The controller is operating in the unoccupied mode and the timed override ON button on the Trane zone sensor is pressed (see Timed Override Control below).
- The controller receives an occupied bypass signal from a BAS.

In occupied bypass mode, the controller maintains the space temperature based on the occupied heating or cooling setpoints. The fan runs as configured (continuous or cycling). The outdoor air damper closes when the fan is OFF. The controller remains in occupied bypass mode until either the CANCEL button is pressed on the Trane zone sensor or the occupied bypass time expires (configured using the Tracer TU service tool). The temperature setpoints can be configured as local (hard wired), communicated, or stored default values using the Tracer TU service tool.

## Timed Override Control

If the zone sensor has a timed override option (ON/CANCEL buttons), pushing the ON button initiates a timed override on request. A timed override upon request changes the occupancy mode from unoccupied mode to occupied bypass mode. In occupied bypass mode, the controller controls the space temperature based on the occupied heating or cooling setpoints. The occupied bypass time, which defines the duration of the override and resides in the controller, is configured from 0 to 240 minutes (default value of 120 minutes). When the occupied bypass time expires, the controller transitions from occupied bypass mode to unoccupied mode.

Pushing the CANCEL button cancels the timed override request. In addition, it ends the timed override before the occupied bypass time has expired and transitions the unit from occupied bypass mode to unoccupied mode. If the controller is in any mode other than unoccupied mode when the ON button is pressed, it still starts the occupied bypass timer without changing to occupied bypass mode. If the controller is placed in unoccupied mode before the occupied bypass timer expires, it is placed into occupied bypass mode and remains in this mode until either the CANCEL button is pressed on the Trane zone sensor or the occupied bypass time expires.

## Heat/Cool Operation

### Cooling

During the cooling mode, the UC400 Controller uses one of the following cooling modes to maintain the space temperature at the active cooling setpoint:

- Occupied Cooling
- Occupied Standby Cooling
- Unoccupied Cooling

The UC400 Controller uses the measured space temperature and the active cooling setpoint along with the control algorithm, to determine the requested cooling capacity of the unit (0-100%). The outputs are controlled based on the unit configuration and the requested cooling capacity.

**Note:** If humidity control is enabled, refer *“Other Modes,” p. 43.*

### Heating

During the heating mode, the UC400 Controller uses one of the following heating modes to maintain the space temperature at the active heating setpoint:

- Occupied Heating
- Occupied Standby Heating
- Unoccupied Heating

The UC400 Controller uses the measured space temperature and the active heating setpoint, along with the control algorithm, to determine the requested heating capacity of the unit (0-100%). The outputs are controlled based on the unit configuration and the requested heating capacity.

## Fan Operation

The UC400 Controller can be configured to operate as a 1- or 2-speed fan or as a variable speed fan in a Single Zone VAV. When the fan is in any occupied mode (including standby and bypass), the fan can be set up to cycle with heat/cool demand or to continuously run regardless of demand. The fan defaults to continuous operation, but can be adjusted by toggling BV/1 Supply Fan Configuration Command. When the fan is in unoccupied mode, the fan turns on only when the unoccupied setpoints are not being met. The fan mode request can be either communicated through a BAS or hard wired to the controller from a fan switch. In all configurations, the fan can be controlled off when the manual output test has been initiated or a latching diagnostic is present.

## Single-Zone VAV/Variable Speed Fan Operation

When configured with a variable speed fan, the UC400 Controller treats all active fan mode request (with the exception of OFF) as AUTO. When in AUTO, the controller ramps up the fan as necessary between the lowest and highest speeds in order to meet the demand of the space or in order to satisfy minimum airflow setting of the unit for specific heating/cool modes (whichever is higher). The setpoints

below can be adjusted as necessary to meet individual specifications. The following setpoints cannot be configured below the lowest possible speed of the fan:

- **AV/20 Supply Fan Speed Ventilation:** when configured for continuous operation, this is the speed at which the fan operates when heating and cooling stages are not active.
- **AV/19 Supply Fan Speed First Stage Minimum:** the lowest speed the fan operates when in the first stage of heating or cooling. The fan ramps up from this point as necessary to meet demand. Capacity must be at 100% for 10 minutes before the fan will ramp to AV/17 setting.
- **AV/17 Supply Fan Speed Maximum Heat Cool Capacity:** When electric heat is not active, or a single stage of compressor is active, the fan modulates between AV19 and AV17 to meet demand. When electric heat is active or the second stage of compressor is active the fan will run at AV17.
- **AV/18 Supply Fan Speed Dehumidification:** the speed the fan operates in the active dehumidification mode.

### Constant Torque ECM Fans

On vertical models of EX and DX units in ½ Ton to 6 Ton sizes the supply fans are shipping from the factory programmed as Constant Torque instead of Constant CFM. This change is represented with a letter “G” as the 4th digit of the model number.

The Constant Torque fans use the same control logic in the controller, but the fan motors are programmed differently and are not interchangeable with the Constant CFM versions. The settings for the fan parameters in the controller must be set correctly to ensure proper equipment operation. Refer to [Table 11, p. 39](#) for proper settings.

If adjustments are made to the maximum fan speed (AV17 Supply Fan Speed Maximum Heat Cool Capacity), then the scaling factor (AV22 Supply Fan Scaling Factor) will be used to recalculate the default values for the low setting (AV18 Supply Fan Speed Dehumidification, AV19 Supply Fan Speed First Stage Minimum, and AV20 Supply Fan Speed Ventilation). AV20 Supply Fan Speed Ventilation is the only low setting that can be adjusted from the default settings and if adjusted by the user the factory recalculation will not take effect.

#### Notes:

- *Constant Torque ECM Fans are available on UC400 controllers with System Build 3.00 and newer.*
- *On Constant Torque ECM Fan motors a 0% signal represents Off. On Constant CFM ECM Fan motors a 0% signal represents low speed.*

**Table 11. Constant torque supply fan default settings**

| Efficiency              | Size     | High Setting AV17 | Low Setting AV18, AV19, or AV20 (Mode Dependent) | Minimum Setting | Scaling Factor AV22 |
|-------------------------|----------|-------------------|--|-----------------|---------------------|
| Standard Efficiency     | GE*G 006 | 60%               | 30%  | 20%             | 0.5                 |
|                         | GE*G 009 | 60%               | 30%  | 20%             | 0.5                 |
|                         | GE*G 012 | 60%               | 30%  | 20%             | 0.5                 |
|                         | GE*G 015 | 60%               | 30%  | 20%             | 0.5                 |
|                         | GE*G 018 | 60%               | 30%  | 20%             | 0.5                 |
|                         | GE*G 024 | 60%               | 30%  | 20%             | 0.5                 |
|                         | GE*G 030 | 60%               | 30%  | 20%             | 0.5                 |
|                         | GE*G 036 | 60%               | 30%  | 20%             | 0.5                 |
|                         | GE*G 042 | 60%               | 30%  | 20%             | 0.5                 |
|                         | GE*G 048 | 60%               | 30%  | 20%             | 0.5                 |
|                         | GE*G 060 | 76%               | 38%  | 20%             | 0.5                 |
| High Efficiency         | EX*G 009 | 60%               | 30%  | 20%             | 0.5                 |
|                         | EX*G 009 | 60%               | 30%  | 20%             | 0.5                 |
|                         | EX*G 009 | 60%               | 30%  | 20%             | 0.5                 |
|                         | EX*G 018 | 60%               | 30%  | 20%             | 0.5                 |
|                         | EX*G 024 | 60%               | 30%  | 20%             | 0.5                 |
|                         | EX*G 030 | 60%               | 30%  | 20%             | 0.5                 |
|                         | EX*G 036 | 60%               | 30%  | 20%             | 0.5                 |
|                         | EX*G 042 | 60%               | 30%  | 20%             | 0.5                 |
|                         | EX*G 048 | 60%               | 30%  | 20%             | 0.5                 |
|                         | EX*G 060 | 67%               | 34%  | 20%             | 0.5                 |
|                         | EX*G 070 | 84%               | 42%  | 20%             | 0.5                 |
| 2 Stage High Efficiency | DX*G 024 | 60%               | 30%  | 20%             | 0.5                 |
|                         | DX*G 036 | 60%               | 30%  | 20%             | 0.5                 |
|                         | DX*G 060 | 67%               | 34%  | 20%             | 0.5                 |
|                         | DX*G 070 | 84%               | 42%  | 20%             | 0.5                 |

**Notes:**

1. The minimum setting is enforced to protect equipment.
2. The full range of the PWM is scaled between 0%-100% with 20% being the minimum signal.

**Example:**

Determining low fan speeds GEVG 036 Unit:

$AV17 * AV22 = 60\% * 0.5 = 30\%$  for the factory default value applied to AV18/19/20.

If AV17 has been changed in the field to 68% the low settings will be recalculated accordingly.

$68\% * 0.5 = 34\%$  for the new default value applied to AV18/19/20.

If AV17 is adjusted in the field low enough that it causes the low settings to fall below the min setting.

$39\% * 0.5 = 19\%$  so the minimum setting of 20% will be applied as the new default to AV18/AV19/AV20.

If AV20 is overridden and AV17 is adjusted, the newly recalculated default values will not take effect on AV20 and it will continue to use the overridden value, and a manual adjustment may be required.

## 1– and 2–Speed Fan Operation

When using a 2-speed fan, the UC400 Controller can be configured for default operation by adjusting the Cooling Fan Speed Default and Heating Fan Speed Default. Both of these values are factory-installed and are set to AUTO.

**Table 12. Fan speed arbitration for 1–, 2–speed fans**

| Inputs                                      |  | Result                |
|---|--|-----------------------|
| Supply Fan Staged Speed Setpoint BAS (MV/8) | Supply Fan Speed Setpoint Local (MI/2) |                       |
| Auto  | Auto                                   | Auto                  |
| Auto  | Off                                    | Off                   |
| Auto  | Low                                    | Low <sup>(a)</sup>    |
| Auto  | Medium                                 | Medium <sup>(b)</sup> |
| Auto  | High                                   | High                  |
| Off   | X <sup>(c)</sup>                       | Off                   |
| Low   | X <sup>(c)</sup>                       | Low                   |
| Medium                                      | X <sup>(c)</sup>                       | Medium <sup>(b)</sup> |
| High  | X <sup>(c)</sup>                       | High                  |
| Invalid or not present                      | Invalid or not present                 | Auto                  |

<sup>(a)</sup> 1–speed fan will interpret low as high.

<sup>(b)</sup> 1– and 2–speed fans interpret medium a high.

<sup>(c)</sup> Any value is applicable.

## Fan Off Delay

If the fan is configured for cycling and the heating output is controlled OFF, the UC400 Controller automatically holds the fan ON for an additional 30 seconds. This 30–second delay gives the fan time to blow off any residual heat from the heating source. To adjust the Fan Off Delay, use the Tracer TU service tool to change AV/9 Supply Fan Off Delay Time.

## Entering Water Temperature Sampling Function

The UC400 Controller samples the Entering Water Temperature (EWT) to determine proper control action for units equipped with boiler-less electric heat, or Waterside Economizer (WSE). Each unit is treated as having isolation valves, whether present or not. If the EWT is communicated to the controller through a BAS, or if sampling is not desired, it can be turned off by setting BV/9 Water Temperature Sampling Enable to disabled. If the EWT is present as a hard wired input and communicated from a BAS, the communicated value is used. When the EWT sample is used, the isolation valve is driven open for three (3) minutes and the EWT reading is recorded at that time. To avoid sampling each time a new cooling/heating request is initiated, the last EWT value recorded is used for the next hour. During boiler-less control heating, if the setpoint has not been achieved following the one (1) hour, a new EWT reading is recorded and the appropriate control action taken. During WSE and compressor (DX) operation, the EWT is refreshed as often as the analog input is polled.

### Sampling for Waterside Economizer Units

EWT is used to determine whether WSE operation is feasible. If the EWT meets the configured Economizer Enable Minimum Water Temperature Setpoint, WSE operation is possible. EWT sampling activates when the following conditions have been met:

- BV/9 (Water Temperature Sampling Enable) is enabled.
- EWT is not communicated through a BAS and the unit is equipped with a WSE, then following must occur:
  - A new control request for cooling, isolation valve is closed, and more than one (1) hour has passed since the last EWT sample.



When the above conditions have been met, Isolation Valve is opened for three (3) minutes, the EWT reading is recorded, and WSE operation feasibility is determined. The isolation valve remains open regardless.

### Sampling for Electric Heat Units

For units equipped with electric heat and configured for boiler-less control, EWT is used to determine whether DX heating should be disabled and electric heat enabled. EWT sampling is activated when the following conditions are met:

- BV/9 (Water Temperature Sampling Enable) is enabled.
- If the EWT is not communicated through a BAS and the unit is equipped with electric heat configured for boiler-less control is not a cooling-only unit, then following must occur:
  - There is a new control request for cooling, isolation valve is closed, and more than one (1) hour has passed since the last EWT sample; **OR**
  - The boiler-less electric heat is running and more than one (1) hour has passed since the last EWT sample.

When the above conditions have been met, Isolation Valve is opened for three (3) minutes, the EWT reading is recorded, and electric heat operation feasibility is determined. If boiler-less electric heat is enabled, the isolation valve closes, which halts water flow to the unit.

**Table 13. EWT sampling when enabled unit configurations**

| EWT Sampling Enabled by Default | Unit Build Configuration                    |
|---------------------------------|---|
| No                              | Heat pump (HP)                              |
| Yes                             | HP with WSE                                 |
| Yes                             | HP + electric heat (boiler-less)            |
| Yes                             | HP + electric heat + WSE                    |
| No                              | HP + electric heat (concurrent)             |
| Yes                             | HP + electric heat (concurrent) + WSE       |
| No                              | Cooling only                                |
| Yes                             | Cooling only with WSE                       |
| No                              | Cooling + electric heat (boiler-less)       |
| Yes                             | Cooling + electric heat (boiler-less) + WSE |

### Waterside Economizer Operation

The UC400 Controller supports the use of a 2-position waterside economizer (WSE). The WSE is only active in cooling mode and if the AV/5 Entering Water Temperature Active is lower than AV/8 Economizer Enable Minimum Water Temperature Setpoint. If the zone requires cooling and the WSE is enabled, the WSE valve opens and begins controlling the zone. If the WSE capacity cannot cool the zone, then stage-1 of the compressor cooling is allowed to operate with WSE. Stage 2 of compressor cooling is not allowed to run under any circumstances when the WSE is on. The WSE enable setpoint may need to be reduced in order to increase unit capacity. When the WSE and the compressor are running simultaneously, coil frosting may occur. The controller controls two (2) devices to prevent this from occurring.

### Coil Icing Protection

A fixed temperature device is mounted to the evaporator coil and wired to a binary input on the UC400 Controller. When the binary input on the controller trips (in alarm situations), the actions shown the following table occur. This low-level diagnostic automatically resets when the binary input changes to the normal state. The compressor minimum ON and OFF times (3 minutes) is enforced during this mode.

**Table 14. Coil icing**

| Cooling Mode              | Control Action            |
|---------------------------|---------------------------|
| Economizer                | None                      |
| Economizer and Stage-1 DX | Disable Stage-1 DX        |
| Stage-1 and Stage-2 DX    | Disable DX Stages 1 and 2 |

**Note:** The fan remains ON during this operation.

### Low Leaving Air Protection

This mode is activated during WSE operation and controlled by the discharge air sensor. If the discharge air temperature drops below the AV/21 Discharge Air Temperature Low Limit Setpoint (default 47° F) for one (1) minute, the following actions occur as shown in the following table. This low-level diagnostic automatically resets when the binary input changes to the normal state. The compressor minimum ON and OFF times (3 minutes) is enforced during this mode.

**Table 15. Low Leaving air**

| Cooling Mode              | Control Action     |
|---------------------------|--------------------|
| Economizer                | None               |
| Economizer and Stage-1 DX | Disable Stage-1 DX |
| Stage-1 and Stage-2 DX    | None               |

**Note:** The fan remains ON during this operation.

## Electric Heat Operation

The UC400 Controller supports stage-1 electric heat by three methods:

- Supplemental
- Boiler-less
- Main Heat

### Supplemental

When applied, the electric heat is cycled ON as the last stage of heating. Compressor 1 and 2 (where applicable) energize and the electric heat operates concurrently with the compressors, as needed, to maintain space temperature.

### Boiler-less

When applied, the electric heat enables based on the Entering Water Temperature (EWT). Both the compressor(s) and electric heat are not allowed to operate at the same time. Boiler-less electric heat is controlled by the EWT and compressor heat disable setpoint. If the unit is in the heating mode and EWT falls below the compressor heat disable setpoint, the compressor is then disabled for heating and the electric heat cycles to maintain temperature. Boiler-less control disables if the EWT rises 5°F degrees above the compressor heat disable setpoint. The EWT value can be either local or communicated. In applications where the local water sensor is used, the unit may utilize the Entering Water Temperature Sampling function to verify water temperature.

### Main Heat

The electric heat is utilized as the only form of heat for the unit. The compressor and electric heat do not operate at the same time. When in the heating mode, the electric heat cycles to maintain space temperature.

### Compressor Cooling (DX)

The UC400 Controller supports two (2) stages of DX cooling. The control is proportional and based on an error rate of 3°F degrees for single compressor operation and 5°F degrees for 2-compressor units.

Zone temperature is compared against active setpoints for compressor operation. OFF, pulse width modulation (PWM), or ON are how the compressor can be controlled.

**Note:** When the control is in the dehumidification mode, only OFF and ON are valid compressor states.

At startup or during mode transition, if both compressors are requested to run, Compressor 1 is energized first and Compressor 2 waits until the next control cycle (10 seconds) to energize.

### Water Isolation Valves

The UC400 Controller supports the operation of a water isolation valve for variable speed pumping systems. The controller operates as if an isolation valve is always present. The presence or absence of an isolation valve is not a configuration factor. Under normal operation, the controller opens the isolation valve under the following conditions:

- DX Heating request.
- DX Cooling or WSE request.
- When control is in DX heat or cool mode and is controlling with pulse width modulation, the valves remain open during the pulse width modulation cycle.
- Active dehumidification request.
- EWT sampling request; valves remain open for three (3) minutes.
- Manual testing.
- During DX operation; the valves open for 20 seconds to ensure adequate water flow before energizing the compressor outputs.
- Upon opening, the valve remains open for a minimum of 10 minutes to reduce excessive valve cycling.

Isolation Valve 1 must remain open when the control is in an active cooling, heating, or active dehumidification mode. If Circuit/Compressor 1 is taken off line, Isolation Valve 1 remains open to allow operation of Circuit 2. Under normal operation, the isolation valves are closed under the following conditions:

- When the compressor and WSE are controlled OFF and the when the 10-minute minimum ON has expired.

**Note:** If the WSE is disabled due to the economizer enable parameter, or through the BAS system and cooling demand is present, the isolation valve remains open for compressor operation.

- Power is lost, valves de-energize to the closed position.
- Manual test OFF.

## Other Modes

### Active Dehumidification

The UC400 Controller controls the zone to the active cooling setpoint using proportional control. In addition, it also controls one (1) stage of DX cooling in conjunction with one (1) state of reheat. The only supported active dehumidification type during this period is hot gas reheat.

The factory-supplied UC400 Controller supports one (1) binary output for the control of a 2-position hot gas reheat solenoid valve. This valve is normally closed and opens when energized, providing the flow of hot refrigerant gas through the reheat coil. The reheat coil is sized to provide neutral air at 75°F loop condition with 75°F dry bulb return air at 75% relative humidity. When in the active dehumidification mode, only the first stage DX cooling is allowed to run on 2-stage units.

Active dehumidification can occur only when the controller is in the cooling mode. Active dehumidification is not allowed in heating mode. Active dehumidification can be active during all times of day schedules.

A humidity sensor is used to measure the zone relative humidity and is compared against the relative humidity enable/disable setpoints. Relative humidity level can be communicated to the controller from a BAS. The default values for active dehumidification enable is 60% relative humidity. Disable point is 52% relative humidity. These values are configured by adjusting AV/68, Space Relative Humidity Deadband.

To avoid sub-cooling the space if the reheat is not sized properly, or during certain system conditions, a low limit temperature is established to exit active dehumidification mode. The low limit is the active cooling setpoint in the Occupied and Unoccupied standby modes.

In the Unoccupied mode, the default occupied cooling setpoint is used as the low limit. This enables extended active dehumidification during unoccupied modes, which allows sub-cooling the space to the default Occupied setpoint. If the zone temperature reaches the low limit, the DX cooling and reheat are turned off. The zone temperature must rise a 0.75°F degree above the low limit before the DX cooling and reheat are allowed to operate again.

**Note:** *While in the active dehumidification mode, if there is a call for capacity by the unit the zone temperature setpoint will take priority over the relative humidity setpoints.*

Active dehumidification occurs during the following:

- Unit mode = cooling
- Relative humidity > enable setpoint

Reheat in the active dehumidification mode is utilized under the following condition:

- Zone temperature is above the active cooling setpoint.
- Zone temperature < 1.5°F degrees above the active cooling setpoint.

Compressor 2 is not on at the same time as the reheat solenoid. For both single and 2-stage cooling, the following conditions cause the UC400 Controller to transition out of active dehumidification mode:

- Relative humidity < Disable setpoint
- Unit Mode = Heating

### Passive Dehumidification

Passive dehumidification slows down the approach to zone temperature setpoint to run compressor longer and remove more moisture during the cooling cycle.

The factory-supplied UC400 supports passive dehumidification on one stage or two stage, single compressor units with an ECM fan. A relative humidity sensor and discharge air temperature sensor must be installed. If hot gas reheat is present, then active dehumidification will run instead of passive dehumidification. Two compressor units do not support passive dehumidification at this time.

**Note:** *Passive dehumidification is available on UC400 controllers with System Build 3.00 and newer.*

To enter passive dehumidification mode the following conditions must be met:

- Unit must be in cooling mode.
- Passive dehumidification (BV21 Passive Dehumidification Enable) must be enabled.
- Controller must be in occupied, occupied standby, or occupied bypass mode.
- A valid humidity value must be provided. This can be provided through a wired or wireless sensor input or communicated through the BAS.
- The active humidity value must be greater than the dehumidification setpoint (AV6 Space Humidity Active > AV36 Space Dehumidification Setpoint BAS).
- The active space temperature must be greater than the occupied cooling setpoint minus ½ degree (AV59 Space Temperature Active > AV28 Space Temperature Setpoint Active - 0.5°F).
- The discharge air temperature must be greater than the dehumidification discharge air temperature setpoint plus 1 degree (AI4 Discharge Air Temperature > AV39 Dehumidification Discharge Air Setpoint BAS + 1°F).
- It has been a minimum of 10 minutes since exiting the last passive dehumidification session.
- Fan must be at minimum speed or off (cycling fan).
- Water side economizing is not available.

When the unit enters passive dehumidification mode, the fan will stay at active minimum setpoint for a minimum of three minutes. At the end of the three minutes, the fan will be allowed to modulate, to max fan speed, slowly helping to remove moisture content in the air and minimizing the effect on space temperature. During passive dehumidification the compressor will run at 100% capacity. The fan will modulate to maintain discharge air dehumidification setpoint (AV39 Dehumidification Discharge Air

Setpoint BAS). When running in passive dehumidification mode “Dehumidification” will be reported by MV5 Heat Cool Mode Status.

To exit passive dehumidification mode one of the following conditions must be met:

- Unit is no longer in cooling mode.
- The active humidity value drops below the dehumidification setpoint minus the dehumidification dead band (AV6 Space Humidity Active < AV36 Space Dehumidification Setpoint BAS – AV68 Space Relative Humidity Deadband).
- The active space temperature is greater than 2 degrees above the active setpoint for 10 minutes with less than ½ degree drop in the 10 minutes. At this the control aborts passive dehumidification and applies cooling control.
- The active space temperature is 1.5 degrees below active setpoint.

### **Defrost**

For defrost operation, a sensor is wired to a binary input on the UC400 Controller. When a defrost condition is detected, the compressor(s) are disabled and the unit is placed in the defrost mode. During defrost, the compressor(s) are OFF and the fan continuously operates. The unit remains in the defrost mode until the sensor resets and the unit returns to normal operation after the mode is discontinued.

### **Pre-Heat**

The UC400 Controller keeps the 2-position outdoor air damper closed anytime during the occupied mode when the space temperature is 3°F degrees or more below the heating setpoint. The damper remains closed indefinitely during morning pre-heat until the space temperature is within 2°F degrees of the effective heating setpoint. The unit runs at full capacity until setpoint is met.

### **Pre-Cool**

The UC400 Controller keeps the 2-position outdoor air damper closed for up to one (1) hour at every transition from unoccupied to occupied mode when the space temperature is 3°F degrees or higher above the cooling setpoint. The damper remains closed during pre-cool until the space temperature is within 2°F degrees of the effective cooling setpoint. The unit runs at full capacity until the setpoint is met.

### **Fan Status**

There are two (2) methods to perform fan status monitoring:

- The status of the fan is reported based on the state of the binary output(s) dedicated to fan control. The Supply Fan Speed Status (AV/73) is reported as ON (100%) whenever the corresponding binary output is directed ON. The Supply Fan Speed Status is reported as OFF (0%) when the fan output is directed OFF.
- The UC400 Controller has an optional binary input available for a fan status device (current sensing relay) which can provide feedback of fan operation. If the device does not indicate fan operation after one (1) minute as commanded ON, a unit shut down is initiated, the unit is latched OFF, and a diagnostic is generated (see [Table 16, p. 46](#)).

### **Filter Status and Maintenance Timer**

The unit filter status/maintenance timer is based on the cumulative run hours of the unit fan. The UC400 Controller compares the fan run time against an adjustable Filter Runtime Hours Setpoint (AV/12), and recommends unit maintenance as required. The Tracer TU service tool is used to edit the maintenance required setpoint time. After exceeding the setpoint limit, the controller generates a maintenance required informational diagnostic. When the setpoint time is set to zero, this feature is disabled by the controller. The Tracer TU service tool is required to clear the Maintenance Required informational diagnostic. After the diagnostic is cleared, the UC400 Controller resets the fan runtime to zero and begins accumulating fan run hours again. If at any time the unit loses power, the timer is reset to zero.



# Operational Troubleshooting

This section provides information about the various diagnostics and troubleshooting for the UC400 Controller.

**⚠ WARNING**

**Live Electrical Components!**  
 Failure to follow all electrical safety precautions when exposed to live electrical components could result in death or serious injury.  
 When it is necessary to work with live electrical components, have a qualified licensed electrician or other individual who has been properly trained in handling live electrical components perform these tasks.

## Diagnostics

**Table 16. UC400 controller diagnostics**

| Diagnostic  | Unit Response  | Latching/non-latching | Reset   |
|---|--|-----------------------|---|
| High/Low Pressure Cutout/Freeze Protection  | <ul style="list-style-type: none"> <li>Fan OFF</li> <li>Valves Closed</li> <li>Compressor OFF</li> </ul> <p><i>Note: In a 2-compressor unit, the unit continues to operate if a compressor is available.</i></p> | Latching              | Auto-reset once every 24 hours. If safety generate a diagnostic more than once, a communicated or manual reset is required. |
| Low Air Flow/Fan Failure<br><br>This diagnostic is generated when a fan status device is present and fails to close after one minute of unit startup, or when it opens for more than one minute during normal unit operation. | <ul style="list-style-type: none"> <li>Fan OFF</li> <li>Valves Closed</li> <li>Compressor OFF</li> </ul>   | Latching              | Communicated or manual reset is required.   |
| Space Temperature Failure <sup>(a)</sup><br><br>If space temperature is invalid or not present, a space temperature alarm occurs.   | <ul style="list-style-type: none"> <li>Fan OFF</li> <li>Valves Closed</li> <li>Compressor OFF</li> </ul>   | Non-latching          | Auto resets.  |
| Entering Water Temperature Failure<br><br>If the Entering Water Temperature is configured but invalid or not present, an entering water temperature alarm occurs.   | <ul style="list-style-type: none"> <li>Fan Enabled</li> <li>No Boiler Control Disabled</li> <li>Waterside Economizer Enabled</li> </ul>  | Non-latching          | Auto resets.  |
| Discharge Air Temperature Limit<br><br>When the discharge air exceeds the low limit setpoint and the unit cannot correct it by altering capacity, a Discharge Air Temp Low Limit diagnostic is generated.                     | <ul style="list-style-type: none"> <li>Fan on</li> <li>Waterside Economizer enabled</li> <li>compressor disabled</li> </ul>  | Non-latching          | Auto-reset once every 24 hours. If safety generate a diagnostic more than once, a communicated or manual reset is required. |
| Humidity Input Failure<br><br>If RH is configured but invalid or not present, a humidity input alarm occurs.  | <ul style="list-style-type: none"> <li>Fan Enabled</li> <li>Valves Enabled</li> <li>Compressor Enabled</li> <li>Reheat Disabled</li> </ul>   | Non-latching          | Auto resets.  |
| CO <sub>2</sub> Sensor Failure<br><br>If CO <sub>2</sub> is configured but invalid or not present, a CO <sub>2</sub> input alarm occurs.  | <ul style="list-style-type: none"> <li>Fan Enabled</li> <li>Valves Enabled</li> <li>Compressor Enabled</li> </ul>  | Non-latching          | Auto resets.  |

**Table 16. UC400 controller diagnostics (continued)**

| Diagnostic   | Unit Response   | Latching/non-latching | Reset                                    |
|--|---|-----------------------|--|
| <b>Filter Change Required</b><br><br>The Filter Change Required diagnostic is generated when the fan run-time exceeds the configured limit. This diagnostic is useful for filter change notification.<br><br><i>Note: If power to the unit is cycled or discontinued for any reason, all maintenance timers automatically reset.</i> | <ul style="list-style-type: none"> <li>• Fan Enabled</li> <li>• Valves Enabled</li> <li>• Compressor Enabled</li> </ul> | Non-latching          | Communicated or manual reset is required |
| <b>Local Fan Mode Failure</b><br><br>If the hard wired fan mode input to the UC400 Controller is invalid, a local fan mode alarm is generated.   | <ul style="list-style-type: none"> <li>• Fan Enabled</li> <li>• Valves Enabled</li> <li>• Compressor Enabled</li> </ul> | Non-latching          | Auto resets.                             |
| <b>Local Setpoint Failure</b><br><br>If the hard wired setpoint input to the UC400 Controller is invalid, a local setpoint alarm is generated.   | <ul style="list-style-type: none"> <li>• Fan Enabled</li> <li>• Valves Enabled</li> <li>• Compressor Enabled</li> </ul> | Non-latching          | Auto resets.                             |
| <b>Defrosting Compressor Lockout:</b> The defrost stat used with the UC400 Controller on DX units is wired in series with the condensing unit. When it opens to indicate a frost condition, the controller senses the open circuit and then de-energizes the compressor output. A defrosting diagnostic is generated at this point.  |   |                       |  |

<sup>(a)</sup> These diagnostics are non-latching and automatically reset when the input is present and valid.

## Override Outputs

Use the Tracer TU service tool to control Multi-state value 12 (MV/12) of the UC400 Controller to any of the specific output test states listed in the table below. There are two (2) output test methods available:

- Overriding Manual Test Sequence (MV/12) to Control the Outputs.
  - Open Tracer TU and select the Multi-state point tab. The TGP2 program controlling the manual test states is at priority level 9. Select a higher priority level in order for the controller to allow the override. The controller automatically returns to normal operation if the override is left in place for a given state for more than one (1) hour.
- Using the UC400 Controller Service Pin to Step Through Manual Output Tests.
  - The manual test mode can also be initiated by pressing and holding the UC400 Controller service pin for two (2) seconds. After pressing the service pin, the service LED illuminates green and then turns off after the TGP2 code has advanced to the next step. At this point, either press the service pin to advance to the next step or stay in the current step for up to one (1) hour. After one (1) hour, the unit automatically returns to Normal Operation. For both manual output test options described above, the unit ignores mechanical safeties such as compressor delays and minimum on/off times. However, if a diagnostic is triggered that would typically force the compressor(s) off, the controller then allows any states that request compressor operation and will advance directly to Normal Operation.

**Table 17. Output test states**

| State   | Mode <sup>(a)</sup>  | ECM Fan Speed | Fan Enable / High | Water Side Economizer | Fan Low    | Comp 1     | Comp 2     | Electric Heat/Hot Gas Reheat | Electric Heat (Units With Both HGR and EH) | Reversing Valve | Isolation Valve | Outdoor Air Damper |
|---|--|---------------|-------------------|-----------------------|------------|------------|------------|------------------------------|--|-----------------|-----------------|--------------------|
| 1   | Off  | AO1<br>OFF    | BO1<br>OFF        | BO2<br>OFF            | BO3<br>OFF | BO4<br>OFF | BO5<br>OFF | BO6<br>OFF                   | XM32 BO1<br>OFF                            | BO7<br>OFF      | BO8<br>OFF      | BO9<br>OFF         |
| 2   | Isolation Valve Open   | OFF           | OFF               | OFF                   | OFF        | OFF        | OFF        | OFF                          | OFF  | OFF             | ON              | OFF                |
| 3   | Fan Low  | MIN           | ON                | OFF                   | ON         | OFF        | OFF        | OFF                          | OFF  | OFF             | ON              | OFF                |
| 4   | Fan High   | MAX           | ON                | OFF                   | OFF        | OFF        | OFF        | OFF                          | OFF  | OFF             | ON              | OFF                |
| 5   | Water Side Economizer  | MAX           | ON                | ON                    | OFF        | OFF        | OFF        | OFF                          | OFF  | OFF             | ON              | OFF                |
| 6   | Compressor Cool Stage 1  | MAX           | ON                | OFF                   | OFF        | ON         | OFF        | OFF                          | OFF  | ON              | ON              | OFF                |
| 7   | Compressor Cool Stage 2  | MAX           | ON                | OFF                   | OFF        | ON         | ON         | OFF                          | OFF  | ON              | ON              | OFF                |
| 8   | Hot Gas Reheat   | MAX           | ON                | OFF                   | OFF        | ON         | OFF        | ON                           | OFF  | ON              | ON              | OFF                |
|   | Units Without Hot Gas Reheat   | MAX           | ON                | OFF                   | OFF        | OFF        | OFF        | OFF                          | OFF  | ON              | ON              | OFF                |
| 9   | Elec Heat Only (Boilerless)  | MAX           | ON                | OFF                   | OFF        | OFF        | OFF        | ON                           | OFF  | OFF             | ON              | OFF                |
|   | Concurrent (DX Heat + Elec Heat)                                     | MAX           | ON                | OFF                   | OFF        | ON         | ON         | ON                           | OFF  | OFF             | ON              | OFF                |
|   | Elec Heat Only (Boilerless) Units Equipped With Both HGR and EH      | MAX           | ON                | OFF                   | OFF        | ON         | OFF        | OFF                          | OFF  | OFF             | ON              | OFF                |
| 10  | Concurrent (DX Heat + Elec Heat) Units Equipped With Both HGR and EH | MAX           | ON                | OFF                   | OFF        | ON         | ON         | OFF                          | ON   | OFF             | ON              | OFF                |
|   | Units Without Elec Heat  | MAX           | ON                | OFF                   | OFF        | OFF        | OFF        | OFF                          | OFF  | OFF             | ON              | OFF                |
| 11  | Compressor Heat Stage 1  | MAX           | ON                | OFF                   | OFF        | OFF        | OFF        | OFF                          | OFF  | OFF             | ON              | OFF                |
| 12  | Compressor Heat Stage 2  | MAX           | ON                | OFF                   | OFF        | ON         | ON         | OFF                          | OFF  | OFF             | ON              | OFF                |
| 13  | Outside Air Damper   | MAX           | ON                | OFF                   | OFF        | OFF        | OFF        | OFF                          | OFF  | OFF             | OFF             | ON                 |
| <b>Turn All Outputs OFF, Then Release to Normal Control Immediately</b> |  |               |                   |                       |            |            |            |                              |  |                 |                 |                    |
| 13  | Normal Operation   | MAX           | ON                | OFF                   | OFF        | OFF        | OFF        | OFF                          | OFF  | OFF             | OFF             | ON                 |

<sup>(a)</sup> A 60 minute time limit will be imposed on each Mode step. Once the timer expires, the unit will transition back to normal control. If the unit is actively operating when a Test Mode is requested, the unit will follow all startup and shutdown requirements to energize/de-energize the compressor and supply fan outputs. If an optional output is not present then the current step is the same as the prior step unless otherwise stated in the table.



## Resetting Diagnostics

The following methods describe resetting unit diagnostics:

- High/Low Pressure Cutout
- Manual Output Test
- Cycling Power
- Building Automation System (BAS)
- Tracer TU Service Tool
- Cycling the Fan Switch

### High/Low Pressure Cutout

The UC400 Controller includes a one-time automatic diagnostic reset function. This function automatically recovers a unit when the High/Low Pressure Cutout diagnostic occurs. When this diagnostic occurs, the controller responds as defined in “Diagnostics,” p. 46. After the controller detects the High/Low Pressure Cutout diagnostic, it waits 30 minutes before invoking the automatic diagnostic reset function. The automatic diagnostic reset function clears the High/Low Pressure Cutout diagnostic and attempts to restore the unit to normal operation. The controller resumes normal operation until another diagnostic occurs. If a High/Low Pressure Cutout diagnostic reoccurs within 24 hours after an automatic diagnostic reset, the diagnostic requires a manual reset.

### Manual Output Test

The service button on the UC400 Controller can be used during installation to verify proper end device operation, or during troubleshooting. When the service button is pressed, the controller exercises all outputs in a predefined sequence. The first and last steps of the sequence reset the controller diagnostics.

### Cycling Power

When turning off the 24 Vac power to the UC400 Controller and then powering on again, the unit cycles through a power-up sequence and clears all timers. By default, the controller attempts to reset all diagnostics at power-up. Diagnostics presented at power-up, and those that occur after power-up, are handled according to the defined unit diagnostics sequences.

### Building Automation System (BAS)

Some building automation systems can reset diagnostics in the Tracer unit controller.

### Tracer TU Service Tool

The Tracer TU service tool can be used to reset diagnostics in the UC400 Controller (from the Alarms tab).

### Cycling the Fan Switch

If the user cycles the fan speed switch from off to ON or AUTO, the UC400 Controller resets all diagnostics. Diagnostics may immediately recur if the problem still exists.



# Operational Causes and Diagnostics

**Table 18. UC400 controller diagnostic causes and diagnostics**

| Probable Cause                               | Diagnostic   |
|--|--|
| <b>Fan Not Energizing</b>                    |  |
| Unit Wiring                                  | The wiring between the UC400 Controller outputs, fan relays, and contacts must be present and correct for normal fan operation.  |
| Failed End Device                            | The fan motor and relay must be checked to ensure proper operation.  |
| Normal Operation                             | <p>The fan turns OFF when:</p> <ul style="list-style-type: none"> <li>• The UC400 Controller receives a communicated off signal.</li> <li>• The fan-speed switch is set to OFF if no communicated value is present.</li> <li>• Specific diagnostics are generated.</li> <li>• The default fan speed is set to OFF and the fan is operating in the Auto mode.</li> </ul> <p>If the UC400 Controller is in unoccupied mode, the fan cycles between OFF and the highest fan speed.</p>    |
| No power to the Controller                   | If the UC400 Controller does not have power, the unit fan does not operate. For the unit to operate normally, it must have an input voltage of 24 Vac. If the Marquee/Power LED is OFF continuously, the controller does not have sufficient power or has failed.  |
| Diagnostic Present                           | Several diagnostics affect fan operation.  |
| Unit Configuration                           | The UC400 Controller must be properly configured based on the actual installed end devices and application. If the unit configuration does not match the actual end device, the fans may not work correctly.   |
| Random Start Observed                        | After power-up, the UC400 Controller always observes a random start from 5 to 30 seconds. The unit remains OFF until the random start time expires.  |
| Cycling Fan Operation/<br>Continuous         | The UC400 Controller continuously operates the fan when in the occupied, occupied standby, or occupied bypass mode. When the controller is in the unoccupied mode, the fan is cycled between high speed and OFF with capacity.   |
| Unoccupied Operation                         | Even if the UC400 Controller is configured for continuous fan operation, the fan normally cycles with capacity during unoccupied mode. While unoccupied, the fan cycles ON or OFF with heating/cooling to provide varying amounts of heating or cooling to the space.  |
| Fan Mode Off                                 | If a local fan mode switch determines the fan operation, the OFF position controls the fan to off.   |
| Requested Mode Off                           | The user can communicate a desired operating mode (such as OFF, heat, and cool) to the controller. If OFF is communicated to the UC400 Controller, it controls the fan to off. There is no heating or cooling.   |
| <b>Isolation Valves Remain Closed</b>        |  |
| Unit Wiring                                  | The wiring between the UC400 Controller outputs and the valve(s) must be present and correct for normal valve operation. Refer to applicable wiring diagram.   |
| Failed End Device                            | The valves must be checked to ensure proper operation.   |
| No power to the Controller                   | If the UC400 Controller does not have power, the unit valve(s) will not operate. For the controller to operate normally, apply an input voltage of 24 Vac. If the Marquee/Power LED is OFF continuously, the unit does not have sufficient power or has failed.  |
| Diagnostic Present                           | Several diagnostics affect valve operation. For detailed information about these diagnostics, refer to Table 13, p. 46.  |
| Normal Operation                             | The UC400 Controller opens and closes the valves to meet the unit capacity requirements.   |
| Unit Configuration                           | The UC400 Controller must be properly configured based on the actual installed end devices and application. If the unit configuration does not match the actual end device, the valves may not work correctly.   |
| Random Start Observed                        | After power-up, the UC400 Controller always observes a random start from 5 to 30 seconds. The controller remains OFF until the random start time expires.  |
| Requested Mode Off                           | The user can communicate a desired operating mode (such as OFF, heat, and cool) to the UC400 Controller. If OFF is communicated to the unit, the controller controls the fan to off. There is no heating or cooling.   |
| Entering Water Temperature<br>Sampling Logic | The UC400 Controller includes entering water temperature sampling logic. It is used to ensure that the loop water is within appropriate operating temperatures for compressor heating/cooling or valid for waterside economizing. When communicating a Source Water Temperature from a BAS, ensure that there is a valid Entering Water Temperature Active. If it is known that sampling is not required, toggling the Entering Water Sampling Enable BV to disabled can be performed. |

**Table 18. UC400 controller diagnostic causes and diagnostics (continued)**

| Probable Cause                                     | Diagnostic  |
|--|---|
| Valve Configuration                                | Ensure the valves are correctly configured, using the Tracer TU service tool, as normally open (NO) or normally closed (NC) as dictated by the application.   |
| <b>Isolation Valves Remain Open</b>                |   |
| Unit wiring  | The wiring between the UC400 Controller outputs and the valve(s) must be present and correct for normal valve operation. Refer to applicable wiring diagram.  |
| Failed End Device                                  | The valves must be checked to ensure proper operations.   |
| Normal Operation                                   | The UC400 Controller opens and closes the valves to meet the unit capacity requirements.  |
| Diagnostic Present                                 | Several diagnostics affect valve operation.   |
| Unit Configuration                                 | The UC400 Controller must be properly configured based on the actual installed end devices and application. If the unit configuration does not match the actual end device, the valves may not work correctly.  |
| Entering Water Temperature Sampling Logic          | The UC400 Controller includes entering water temperature sampling logic. It is automatically initiated during 2-pipe and 4-pipe changeover if the entering water temperature is either too cool or too hot for the desired heating or cooling.  |
| Valve Configuration                                | Ensure the valves are correctly configured, using the Tracer TU service tool, as normally open (NO) or normally closed (NC) as dictated by the application.   |
| <b>DX or Electric Heat Outputs Do Not Energize</b> |   |
| Unit Wiring  | The wiring between the UC400 Controller outputs and the end devices must be present and correct for normal operation.   |
| Failed End Device                                  | Check the UC400 Controller contactors or the electric heat element, including any auxiliary safety interlocks, to ensure proper operation.  |
| No Power to the Controller                         | If the UC400 Controller does not have power, heat outputs do not operate. For the controller to operate normally, apply an input voltage of 24 Vac. If the Marquee/Power LED is OFF continuously, the controller does not have sufficient power or has failed.  |
| Diagnostic Present                                 | Several diagnostics affect DX and electric heat operation.  |
| Normal Operation                                   | The UC400 Controller controls compressor or electric heat outputs as needed to meet the unit capacity requirements.   |
| Unit Configuration                                 | The UC400 Controller must be properly configured based on the actual installed end devices and application. If the controller configuration does not match the actual end device, DX or electric heat may not operate correctly.  |
| Requested Mode Off                                 | The user can communicate a desired operating mode (such as OFF, heat, and cool) to the UC400 Controller. If OFF is communicated to the unit, the controller shuts off the compressor or electric heat.  |
| Freeze Avoidance                                   | When the fan is OFF with no demand for capacity (0%), and the outdoor air temperature is below the freeze avoidance setpoint, the UC400 Controller disables compressors and electric heat outputs (100%) to prevent coil freezing. This includes unoccupied mode when there is no call for capacity or any other time the fan is OFF. |
| <b>Outdoor Air Damper Remains Closed</b>           |   |
| Unit Wiring  | The wiring between the UC400 Controller outputs and the outdoor air damper must be present and correct for normal outdoor air damper operation. Refer to applicable wiring diagram.   |
| Failed End Device                                  | Check damper actuator to ensure proper operation.   |
| No Power to the Controller                         | If the UC400 Controller does not have power, the outdoor air damper does not operate. For the controller to operate normally, apply an input voltage of 24 Vac. If the Marquee/Power LED is OFF continuously, the controller does not have sufficient power or has failed.  |
| Diagnostic Present                                 | Several diagnostics affect outdoor air damper operation.  |
| Normal Operation                                   | The UC400 Controller opens and closes the outdoor air damper based on the controller's occupancy mode and fan status. Normally, the outdoor air damper is open during occupied mode when the fan is running and closed during unoccupied mode.  |
| Unit Configuration                                 | The UC400 Controller must be properly configured based on the actual installed end devices and application. If the unit configuration does not match the actual end device, the outdoor air damper may not work correctly.  |
| Warm-up and Cool-down Sequence                     | The UC400 Controller includes both a morning warm-up and cool-down sequence to keep the outdoor air damper closed during the transition from unoccupied to occupied. This is an attempt to bring the space under control as quickly as possible.  |
| Requested Mode Off                                 | The user can communicate a desired operating mode (such as OFF, heat, or cool) to the UC400 Controller. If OFF is communicated to the unit, the unit closes the outdoor air damper.   |



## Operational Causes and Diagnostics

**Table 18. UC400 controller diagnostic causes and diagnostics (continued)**

| Probable Cause                         | Diagnostic  |
|--|---|
| <b>Outdoor Air Damper Remains Open</b> |   |
| Unit Wiring                            | The wiring between the UC400 Controller outputs and the outdoor air damper must be present and correct for normal outdoor air damper operation. Refer to applicable wiring diagram.   |
| Failed End Device                      | Check damper actuator to ensure proper operation.   |
| Normal Operation                       | The UC400 Controller opens and closes the outdoor air damper based on the controller occupancy mode and fan status. Normally, the outdoor air damper is open during occupied mode when the fan is running and closed during unoccupied mode.  |
| Unit Configuration                     | The UC400 Controller must be properly configured based on the actual installed end devices and application. If the unit configuration does not match the actual end device, the outdoor air damper may not work correctly.  |
| <b>Erratic Air Flow / Fan Control</b>  |   |
| Unit Configuration                     | If unit is configured with a Constant Torque Motor when it should be configured with a Constant CFM motor. The unit may never produce designed air flow at 100% heating or cooling demand.<br>If unit is configured with a Constant CFM Motor when it should be configured with a Constant Torque motor. The motor may never start at minimum speeds, and at maximum speeds it will be delivering excessive air flow. |



# Configuration and Maintenance

This section outlines the tasks to configure and maintain the UC400 Controller using the Tracer TU service tool.

**Note:** *The UC400 Controller is a self-serviceable unit and is not intended to be disassembled for maintenance.*

1. **Load Application Code on a Blank UC400:** all field programmable UC400 Controllers ship without application code (firmware). Before configuring the controller, check for the unit application code using the Tracer TU service tool, as follows:
  - a. Start the Tracer TU service tool to establish a connection with the UC400 Controller. If no firmware is present, the following message displays: *This UC400 Controller has no application code loaded. Please launch File Transfer wizard and load an appropriate configuration.*
  - b. Click **OK**. To load or upgrade the firmware, follow the procedure in the TU Online Help, *Upgrading Controller Firmware* under the book, *Managing Configurations, Firmware, and Programs*.

2. **Choose a UC400 Configuration Option:**

- a. First, get an overview of the parts of a UC400 Controller configuration. Refer to TU Online Help, *The Main Parts of Device Setup and Configuration* under the book, *An Overview of Device Setup and Configuration book in the Tracer TU Help for Programmable Controllers*.
- b. Carefully read the topic, *Point Configuration Overview* under the book, *Configuring and Managing Points*, for an explanation of available configuration options.

There are two main configuration options:

- Use the Tracer TU Configuration Screen to create a factory configuration.

**Note:** *Some modifications can be made to the Trane factory water source heat pump configuration.*

- Create or edit a custom (field programmed) configuration.

3. **Specify Controller Settings:**

- a. Configure units of measure.
- b. Specify the unit date and time
- c. Specify the baud rate, if other than the default (76800).

4. **Set Up and Discover XM30/XM32/XM70 Expansion Modules:**

- a. Mount, wire, address, and power the expansion module as described in the Installation Instructions that accompany the unit
- b. Click the **Discover** button in the Expansion Modules box on the Controller Settings screen.

**Note:** *When adding an expansion module on the Controller Settings page, but the module is not connected to the controller, then discover it on the Controller Status screen after it is connected and powered.*

Refer to the topic, *Setting Up And Discovering Expansion Modules* under the book, *Modifying Controller Settings*, for the procedural information.

5. **Specifying an Equipment Configuration:** go to the information sources supporting the chosen configuration option.

- a. **Option 1:** use the Tracer TU Configuration Screen to Create a Factory Configuration. Refer to the topics under the *Water Source Heat Pumps (WSHPs)* sub-books about *Configuring and Commissioning Equipment*.
- b. **Option 2:** create a Custom Configuration. This option requires a thorough knowledge of the devices and the network to be installed, including an understanding of the TGP2 programs and the points they use. Complete the following steps:
  - Create points or open a previously created points file, make any edits, and save them to the UC400 Controller. When configuring points for the unit, it is important to note that points are not pre-configured on the controller board. Instead, the board has a certain amount of

memory set aside to create a point. The maximum number of points are listed in the following table.

**Table 19. Max number of points**

| Type              | Number |
|-------------------|--------|
| Analog Input      | 40     |
| Analog Output     | 16     |
| Analog Value      | 128    |
| Binary Input      | 32     |
| Binary Output     | 24     |
| Binary Value      | 48     |
| Multistate Input  | 8      |
| Multistate Output | 8      |
| Multistate Value  | 32     |

**Note:** Create, edit, and load points, either in Tracer TU, or in the TGP2 Editor.

- Specify setpoint values and equipment parameters on the Setpoints and Setup Parameters screens (Equipment Utility).
6. **Commissioning the Hard-Wired Points:** after all points are configured, saved, and downloaded to the UC400 Controller, commission or test them by overriding Output and Value points. Refer to the topics under the book, *Overriding, Comparing, and Changing the Service Status of Points* .
- **Out of Service:**
    - **Inputs/Outputs:** The out of service mode disconnects the point from its reference. With inputs, the point no longer gets the value from its reference, but allows the capability of writing to an input. With outputs, the point no longer pushes its value to its reference. In addition, the value of the point can be changed without affecting the value of reference. However, this still requires the use of the priority table.
    - **Values:** value objects will not accept a written value from on-box applications, such as TGP2 or an area when out of service. An off-box application, such as Tracer TU or Tracer SC, allows the capability of writing to a value object. However, this still requires the use of the priority table. Existing points can be placed in or out of service by clicking the **Control** icon corresponding to the point on the Analog, Binary, or Multi-state tab screens on Status Utility.
- Note:** The priority number must be lower than what the point is currently controlled at in order for the override to be applied. Verify that the device ID and baud rate are correct after restoring a controller using a backup file that was created with a different controller.
7. **Adding Side TGP2 Programs, As Needed:** after completing the hardware points and testing, create or edit TGP2 programs that will run the equipment according to the specified sequence of operations for the job. (Refer to the topics under the *Developing and Managing TGP2 Programs* TOC book in the Tracer Graphical Programming (TGP2) Editor Help for programming procedures. Also refer to the TGP2 Block Reference TOC book to learn how the various blocks work and for information about their properties.
8. **Monitoring and Viewing Point, Alarm, and Controller Status:** refer to the topics under the book, *Viewing the Status of Points and Alarms* .
9. **Backing Up and Restoring Files and Configurations:** upload, backup, replace, or update configuration files, controller firmware, and TGP2 programs using the File Transfer Utility and the Backup Utility. Refer to the topics under book, *Managing Configurations, Firmware, and Files* .



## Resources

- Tracer UC400 Programmable Controller Installation, Operation, and Maintenance Manual (BAS-SVX20-EN).
- Tracer UC400 Programmable Controller Installation Sheet (X39641064-01).
- Tracer TU Online Help Tracer TU Service Tool Getting Started Guide (TTU-SVN01-EN).
- Tracer SC System Controller Installation and Setup (BAS-SVX31-EN).
- BACnet Best Practices and Troubleshooting Guide (BAS-SVX51-EN).
- Tracer Graphics Editor Online Help Tracer Graphical Programming 2 (TGP2) Editor Online Help Tracer Graphical Programming (TGP2) Application Guide (BAS-APG008-EN).
- Tracer XM30 and XM32 Expansion Modules Installation, Operation, and Maintenance Manual (BAS-SVX46-EN).

Trane - by Trane Technologies (NYSE: TT), a global innovator - creates comfortable, energy efficient indoor environments for commercial and residential applications. For more information, please visit [trane.com](http://trane.com) or [tranetechnologies.com](http://tranetechnologies.com).

Trane has a policy of continuous product and product data improvements and reserves the right to change design and specifications without notice. We are committed to using environmentally conscious print practices.

BAS-SVX065F-EN 13 May 2023  
Supersedes BAS-SVX065E-EN (February 2021)

©2023 Trane