



Installation, Operation, and Maintenance

Thermafit™ Modular Air-Cooled

Chiller

Model AMC



⚠ SAFETY WARNING

Only qualified personnel should install and service the equipment. The installation, starting up, and servicing of heating, ventilating, and air-conditioning equipment can be hazardous and requires specific knowledge and training. Improperly installed, adjusted or altered equipment by an unqualified person could result in death or serious injury. When working on the equipment, observe all precautions in the literature and on the tags, stickers, and labels that are attached to the equipment.

February 2024

ARTC-SVX008A-EN

TRANE
TECHNOLOGIES



Introduction

Read this manual thoroughly before operating or servicing this unit.

Warnings, Cautions, and Notices

Safety advisories appear throughout this manual as required. Your personal safety and the proper operation of this machine depend upon the strict observance of these precautions.

The three types of advisories are defined as follows:



Indicates a potentially hazardous situation which, if not avoided, could result in death or serious injury.



Indicates a potentially hazardous situation which, if not avoided, could result in minor or moderate injury. It could also be used to alert against unsafe practices.



Indicates a situation that could result in equipment or property-damage only accidents.

Important Environmental Concerns

Scientific research has shown that certain man-made chemicals can affect the earth's naturally occurring stratospheric ozone layer when released to the atmosphere. In particular, several of the identified chemicals that may affect the ozone layer are refrigerants that contain Chlorine, Fluorine and Carbon (CFCs) and those containing Hydrogen, Chlorine, Fluorine and Carbon (HCFCs). Not all refrigerants containing these compounds have the same potential impact to the environment. Trane advocates the responsible handling of all refrigerants.

Important Responsible Refrigerant Practices

Trane believes that responsible refrigerant practices are important to the environment, our customers, and the air conditioning industry. All technicians who handle refrigerants must be certified according to local rules. For the USA, the Federal Clean Air Act (Section 608) sets forth the requirements for handling, reclaiming, recovering and recycling of certain refrigerants and the equipment that is used in these service procedures. In addition, some states or municipalities may have additional requirements that must also be adhered to for responsible management of refrigerants. Know the applicable laws and follow them.

⚠ WARNING

Proper Field Wiring and Grounding Required!

Failure to follow code could result in death or serious injury.

All field wiring **MUST** be performed by qualified personnel. Improperly installed and grounded field wiring poses **FIRE** and **ELECTROCUTION** hazards. To avoid these hazards, you **MUST** follow requirements for field wiring installation and grounding as described in **NEC** and your local/state/national electrical codes.

⚠ WARNING

Personal Protective Equipment (PPE) Required!

Failure to wear proper PPE for the job being undertaken could result in death or serious injury.

Technicians, in order to protect themselves from potential electrical, mechanical, and chemical hazards, **MUST** follow precautions in this manual and on the tags, stickers, and labels, as well as the instructions below:

- **Before installing/servicing this unit, technicians MUST put on all PPE required for the work being undertaken (Examples; cut resistant gloves/sleeves, butyl gloves, safety glasses, hard hat/bump cap, fall protection, electrical PPE and arc flash clothing). ALWAYS refer to appropriate Safety Data Sheets (SDS) and OSHA guidelines for proper PPE.**
- **When working with or around hazardous chemicals, ALWAYS refer to the appropriate SDS and OSHA/GHS (Global Harmonized System of Classification and Labelling of Chemicals) guidelines for information on allowable personal exposure levels, proper respiratory protection and handling instructions.**
- **If there is a risk of energized electrical contact, arc, or flash, technicians MUST put on all PPE in accordance with OSHA, NFPA 70E, or other country-specific requirements for arc flash protection, PRIOR to servicing the unit. NEVER PERFORM ANY SWITCHING, DISCONNECTING, OR VOLTAGE TESTING WITHOUT PROPER ELECTRICAL PPE AND ARC FLASH CLOTHING. ENSURE ELECTRICAL METERS AND EQUIPMENT ARE PROPERLY RATED FOR INTENDED VOLTAGE.**

⚠ WARNING**Follow EHS Policies!**

Failure to follow instructions below could result in death or serious injury.

- All Trane personnel must follow the company's Environmental, Health and Safety (EHS) policies when performing work such as hot work, electrical, fall protection, lockout/tagout, refrigerant handling, etc. Where local regulations are more stringent than these policies, those regulations supersede these policies.
- Non-Trane personnel should always follow local regulations.

⚠ WARNING**R-454B Flammable A2L Refrigerant!**

Failure to use proper equipment or components as described below could result in equipment failure, and possibly fire, which could result in death, serious injury, or equipment damage.

The equipment described in this manual uses R-454B refrigerant which is flammable (A2L). Use ONLY R-454B rated service equipment and components. For specific handling concerns with R-454B, contact your local representative.

⚠ WARNING**Electrical Shock Hazard!**

Failure to follow instructions below could result in death or serious injury.

Properly connect the system's oversized protective earthing (grounding) terminal(s).

Copyright

This document and the information in it are the property of Trane, and may not be used or reproduced in whole or in part without written permission. Trane reserves the right to revise this publication at any time, and to make changes to its content without obligation to notify any person of such revision or change.

Trademarks

All trademarks referenced in this document are the trademarks of their respective owners.

Product Safety Information

This appliance is not intended for use by persons (including children) with reduced physical, sensory or mental capabilities, or lack of experience and knowledge, unless they have been given supervision or instruction concerning use of the appliance by a person responsible for their safety. Children should be supervised to ensure that they do not play with the appliance.

Maximum altitude of use 3000 meters.

This appliance incorporates an earth connection for functional purposes only.



Table of Contents

Model Number and Coding	7	Installation Piping	21
Chiller Model and Serial Numbers	7	Install Piping and External	
Model Number	7	Components	21
Model Coding Key	7	Initial Flushing of Piping	21
Chiller Description	8	Fill with Water/Glycol Solution	21
Chiller Scope	8	Connecting Module Couplings	22
Chiller Capacities	8	Installation Electrical	23
Component Description	8	Connecting Module Power and Control	
General Data	10	Wires	23
Unit Dimensions and Weights	11	Chiller Module Main Power	23
Pre-Installation	13	Phase Monitor Installation	24
Unit Connections	13	Optional Disconnect Switch	24
Site Preparation and Clearances	13	Module Control Wiring	24
Chiller Clearances	13	Operating Principles	25
Minimum Clearances	13	Refrigeration Circuits	25
Service Access	13	Refrigeration Cycle	25
Mounting Rails	14	Refrigerant R-454B	25
A2L Work Procedures	15	Compressor and Oil System	25
Servicing	15	Condenser and Fans	25
Ignition Source Mitigation	15	Evaporator	25
Ventilation	15	Free-Cooling Operating Modes	25
Refrigerating Equipment	15	Mechanical Cooling Mode	25
Electrical Devices	15	Combined Mechanical and Free-	
Leak Detection	16	Cooling Mode	25
Refrigerant Removal and Evacuation	16	Free-Cooling Only Mode	26
Refrigerant Charging	16	Operating Procedures	27
Decommissioning	17	Operator Interface	27
Installation Mechanical	18	Chiller Power Panels	27
Inspect and Report Damage	18	Panel-Mounted Disconnect	
Inspection of Delivered Equipment	18	Switch	27
Warranty Issues	18	Power Distribution Panels	27
Long Term Storage Requirements	18	Module Electrical and Control	
Factory Preparation	18	Panel	28
Customer Responsibilities	19	Electronic Control	28
Handling of the Modules	19	Controllers	28
Rigging, Lifting, and Moving the		Operating the Microprocessor	29
Chiller	19	Microprocessor Functions	29
		Password Protection	29
		Operator Control	29
		Touchscreen Interface Panel	29
		Touchscreen Interface Tutorial	29

Interface Menu Structure	29	Start-Up	54
Home Screen Features	30	Preparation for Initial Start-Up	54
Modules Layout Screen	33	Initial Start-Up Checklist	54
Module Layout Screen Status		Start-Up	56
Conditions	33	Maintenance Procedures	57
Active Alarms Screen	34	Maintenance Strategy	57
Alarm History	35	Power Disconnect Switch	57
Module Access	37	Federal Clean Air Act	58
Overview Module Screens	37	Inspection and Maintenance Schedule	58
Overview Module	38	Daily	58
Overview Circuits	39	Weekly	59
Module I/O Screens	40	Monthly	59
Digital LEDs	41	Quarterly	60
Analog Inputs	41	Annually	60
Analog Outputs	42	Pump and Tank Maintenance	
Digital Inputs	42	Tasks	61
Digital Outputs	42	Maintenance Tasks	61
Expansion IO Screen 1	42	Inspection Methods	61
Expansion IO Screen 2	43	Critical Cleaning Tasks	61
Trend Screen	43	Pump Tasks	63
Setup Screen	44	Controller Tasks	65
Operator Tasks	45	Chiller Troubleshooting	66
Normal Power Up	45	General Approach to Fault Isolation	66
Emergency Power Shutdown	45	Controller Diagnostic Codes	66
Water Quality Guidelines	46	Compressor Diagnostic Codes	69
Monitor Water Quality	46	CoreSense™ Flash Codes	69
Maintain Glycol Level	46	Phase Monitor Protection	70
Prevent Freezing	47	Symptoms and Solutions	70
Controls Interface	49	Optional Variable Frequency Drive	A-1
Microprocessor Control System	49	Local Control Panel (LCP)	A-1
Primary Microprocessor Controller	49	Warnings and Alarms	A-2
Secondary Microprocessor		Warnings	A-2
Controller	49	Alarms/Trips	A-2
Touchscreen Interface Panel	49	Warning and Alarm Displays	A-3
Operator Control and Monitoring	49	Warning and Alarm Definitions	A-3
Chiller Control	49	Optional Tank and Pump Module	B-1
Power Distribution	49	Tank and Pump Components	B-1
Electrical Controls	50	Fill the Storage Tank	B-2
Refrigeration Controls	50	Variable Flow Tank and Pump Module	
Sequence of Operations	52	Sequence of Operations	B-2
Constant Flow Sequence	52		
Variable Flow Sequence	52		



Table of Contents

Request for Initial Start-up C-1
 Thermafit™ AMC Modular Chiller C-1

Initial Start-Up Agreement C-2



Model Number and Coding

When contacting Trane for technical support, customer service, or parts information, be prepared to provide the model number and serial number of the chiller modules in question. This information is located on the chiller nameplate that is affixed to each module.

Chiller Model and Serial Numbers

For future reference, record the model number and serial number for each module in the chiller in the table below. Refer to the Trane nameplate on each module in the installed unit for the serial number and model number.

Table 1. Chiller reference data

Module	Model Number	Serial Number
1		
2		
3		
4		
5		
6		
7		
8		
9		
10		

Model Number

Critical information for contacting Trane technical support. Reference to the actual chiller module serial number may also be beneficial. Each module has its own unique serial number.

Model Coding Key

Model numbers assigned to Trane systems provide a wealth of information about the features for a chiller's as-built configuration.



Chiller Description

Chiller Scope

This manual provides relevant data to properly operate, maintain, and troubleshoot the Trane Thermafit™ modular AMC chiller. Operator and maintenance personnel must be a qualified refrigeration technician and have a working knowledge of high voltage systems, low voltage control circuits, and components and functions.

Chiller Capacities

The AMC chiller model is available in 15-, 20-, 25-, 30-, 40-, 50-, 60-, and 80-ton capacity modules. Up to 12 modules may connect together in a standard primary/secondary control system. The system can consist of a primary chiller module that contains the primary microprocessor controller, the power distribution panel (if equipped), one or more secondary modules, an optional tank and pump module with a dual lead/lag redundant pumps, glycol feed system, and expansion tank or sealed buffer tank, an optional pump module with dual lead/lag redundant pumps, and an optional free-cooling module. It is important to connect modules in the correct sequence as detailed in Handling of the Modules section of the Installation Mechanical chapter.

The AMC chiller uses dual independent refrigeration circuits in each module with a scroll compressor on each circuit. The brazed-plate evaporator is typically made of SAE Grade 316 stainless steel and 99.9% copper brazing

materials. Standard interconnecting headers are composed of carbon steel.

Water quality must be monitored and maintained by a water treatment professional familiar with the materials of construction and operation of the equipment. As required under Federal regulations, installation, initial start-up, and technical servicing must be performed by a fully qualified personnel only.

⚠ WARNING

Hazardous Voltage!

Failure to disconnect power before servicing could result in death or serious injury.

Disconnect all electric power, including remote disconnects before servicing. Follow proper lockout/tagout procedures to ensure the power can not be inadvertently energized. Verify that no power is present with a voltmeter.

Component Description

Every chiller is comprised of four basic components: compressor, air-cooled condenser, expansion valve, and evaporator. Each AMC chiller module contains one or more of these primary refrigeration components.

Copeland Compressor



The AMC chiller uses a hermetically-sealed scroll compressor on each refrigeration circuit. The Copeland scroll compressor is a state-of-the-art compressor with relay and overload monitoring capabilities designed to accommodate liquids (both oil and refrigerant) without causing compressor damage.

The Copeland compressor uses CoreSense technology (available on select models) as a sensor to unlock advanced capabilities such as protection, diagnostics, communication, and verification. Technicians can make faster, more accurate decisions resulting in improved compressor performance and reliability.

Evaporator



The AMC chiller uses a dual circuit, brazed-plate evaporator on each module constructed of 316 stainless steel plates and copper brazing. The supply and return fluid piping connections to each evaporator uses roll-grooved couplings for service convenience and ease of installation. There are isolation valves on the supply and return piping to allow servicing of each module individually while the remaining modules continue to operate. Each evaporator is insulated with $\frac{3}{4}$ inch closed cell insulation.



General Data

Table 2. General data – Thermafit™ AMC chiller

Capacity (Tons)	15	20	25	30	40	50	60	80
General Unit								
Number of Independent Refrigeration Circuits	DUAL	DUAL	DUAL	DUAL	DUAL	DUAL	DUAL	DUAL
R-454B Refrigerant Charge (lbs/module)	26	30	36	36	50	72	84	86
Chilled Fluid Volume (gal/module)	4.7 ^(a)	5.1 ^(a)	8.9 ^(b)	9.2 ^(b)	13.4 ^(b)	14.6 ^(b)	17.5 ^(b)	20.7 ^(b) /27.1 ^(c)
Compressor								
Type	SCROLL	SCROLL	SCROLL	SCROLL	SCROLL	SCROLL	SCROLL	SCROLL
Quantity	2	2	2	2	2	2	2	2
Evaporator								
Type	BRAZED PLATE	BRAZED PLATE	BRAZED PLATE	BRAZED PLATE	BRAZED PLATE	BRAZED PLATE	BRAZED PLATE	BRAZED PLATE
Quantity	1	1	1	1	1	1	1	1
Fluid Volume (gal)	1.40	1.80	2.30	2.50	4.00	5.00	7.50	7.20
Fouling Factor (hr ft ² -F/Btu)	0.0001	0.0001	0.0001	0.0001	0.0001	0.0001	0.0001	0.0001
Material (plates/brazing)	316 SST/CU	316 SST/CU	316 SST/CU	316 SST/CU	316 SST/CU	316 SST/CU	316 SST/CU	316 SST/CU
Minimum/Maximum Leaving Water Temperatures (°F)	42-65	42-65	42-65	42-65	42-65	42-65	42-65	42-65
Minimum/Maximum Leaving Brine Temperatures (°F)	10-65	10-65	10-65	10-65	10-65	10-65	10-65	10-65
Minimum Water/Brine Operating Pressure (psig)	0	0	0	0	0	0	0	0
Maximum Water/Brine Operating Pressure (psig) Standard Option	200	200	200	200	200	200	200	200
Maximum Water/Brine Operating Pressure (psig) Hi Pressure Option	300	300	300	300	300	300	300	300
Condenser Fans								
Motor Type	EC	EC	EC	EC	EC	EC	EC	EC
HP	1.4	1.4	2.5	2.5	4.2	2.5	2.5	4.2
Fan Type	AXIAL	AXIAL	AXIAL	AXIAL	AXIAL	AXIAL	AXIAL	AXIAL
Air Flow (cfm/module)	14000	14000	21000	21000	23000	42000	42000	46000
Condenser Coils								
Fin Material	ALUM	ALUM	ALUM	ALUM	ALUM	ALUM	ALUM	ALUM
Fin/in (FPI)	12	12	16	16	12	16	16	12
Tube Material	COPPER	COPPER	COPPER	COPPER	COPPER	COPPER	COPPER	COPPER
Tube Diameter (mm)	0.375 (9.5)	0.375 (9.5)	0.375 (9.5)	0.375 (9.5)	0.375 (9.5)	0.375 (9.5)	0.375 (9.5)	0.375 (9.5)
Number of Rows	4	4	3	3	4	3	3	4
Coil Dimensions (in.)	32x64	32x64	36x88	36x88	40x88	36x88	36x88	40x88
Coil Quantity	2	2	2	2	2	4	4	4

^(a) 4-inch pipe headers.

^(b) 6-inch pipe headers.

^(c) 8-inch pipe headers.

Unit Dimensions and Weights

Figure 1. AMC air-cooled modulsars - 15 to 40 tons

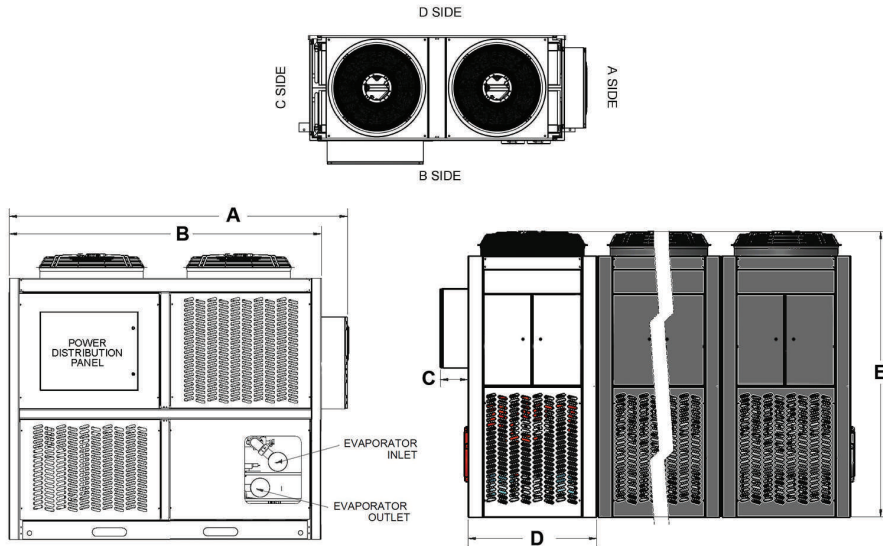
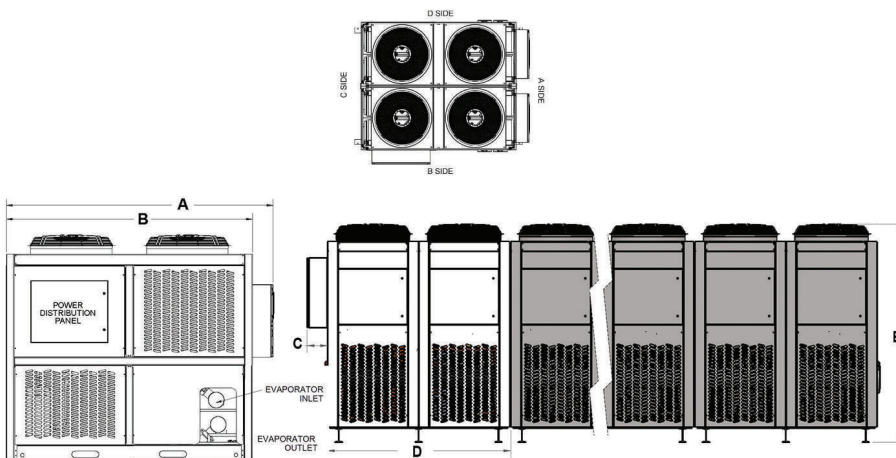

Table 3. Unit dimensions and weight - 15 to 40 tons (AMC)

Dim	Units	Unit Sizes and Weights Per Module				
		15 Tons	20 Tons	25 Tons	30 Tons	40 Tons
A	inch	84	84	103	103	103
B		76	76	95	95	95
C		8	8	8	8	8
D		33	33	39.25	39.25	48
E		76	76	88.75	88.75	89.5
Weight	lbs	1800	1800	2500	2500	3000

Figure 2. AMC air-cooled modulsars - 50 to 80 tons





General Data

Table 4. Unit dimensions and weight - 50 to 80 tons (AMC)

Dim	Units	Unit Sizes and Weights Per Module		
		50 Tons	60 Tons	80 Tons
A	inch	103	103	103
B		95	95	95
C		8	8	8
D		78.5	78.5	96
E		95.25	95.25	96
Weight	lbs	5000	5000	6000



Pre-Installation

Unit Connections

See “[Connecting Module Power and Control Wires](#),” p. 23 to determine the method of the connection of this unit.

Site Preparation and Clearances

Chiller modules must be installed on a level surface that has been checked by a qualified structural engineer to support the weight of the fluid-filled modules and the connective piping to and from the chiller. Installations must account for minimum service access clearances as may be practical or required by local building codes.

Chiller Clearances

One of the most critical factors affecting the performance of air-cooled chillers is air flow above and around the chiller modules. Walls, roofs, overhangs, and nearby mechanical heat sources can all degrade chiller performance. An air-cooled chiller located away from such obstacles operates more efficiently.

Minimum Clearances

The unit must maintain clearance on all sides to provide for adequate ambient air circulation. See [Figure 3](#), p. 14.

The air cooled condensers are designed for outdoor installation and must be mounted level on a roof or concrete slab that is strong enough to support the total equipment operating weight. Consult a professional structural engineer to determine safe mounting loads.

Unrestricted airflow must be provided to each condenser. Avoid air recirculation from other nearby equipment. Locate the condenser away from building air vents and heat sources such as exhaust fans.

The unit should be located away from any wall or other obstruction to provide adequate clearance for ambient air intake and discharge.

There should be no obstruction above the chiller module to interfere with fan discharge of heated air. Even a partial overhang of an eave or awning can trap hot air and significantly degrade chiller performance.

Each chiller module must be as far away from any wall or barrier as space allows. Sufficient clearance must be maintained between the chiller modules and any walls or other objects that can interfere with the free flow of air to the condenser coils.

Screening fences must have 50% open surface area, with one foot of bottom clearance, and must not extend higher than the top of the fan grill. Modules should be a minimum of 36 inches away from any fence. Failure to follow these minimum requirements may result in performance degradation.

Modules located in a sub-level or pit, require special considerations to avoid air recirculation and heat buildup. The top of each fan grill must be level with, or higher than, the top of the pit. All sides of the chiller must be minimum 3 ft away away from any side of the pit.

Do not attach ductwork to any fan or fan shroud.

Refrigerant piping should be sufficiently flexible to prevent transmission of noise and vibration into the building.

If the desired location for the chiller is confined by walls, fences, overhanging roof eaves, or is located in a pit (sub-level site), contact Trane to discuss potential impact on equipment performance.

The National Electric Code or local, state, and regional building codes may require greater clearance for the modular chiller than the figures listed in this publication. Always consult local regulatory agencies to confirm any additional clearances required by building codes.

Service Access

Clearance must be maintained between the module and any nearby wall or impediment to provide sufficient room to open power distribution panel and electrical and control panel doors for routine maintenance and servicing. The NEC requires 42-inch clearance to allow panel doors to fully swing open and to meet local and national electrical codes. Compressors, filter-strainers, and liquid line shutoff valves are accessible on each side or end of each chiller.

Figure 3. Recommended chiller clearances

Service Clearances

No obstructions above units (top view)

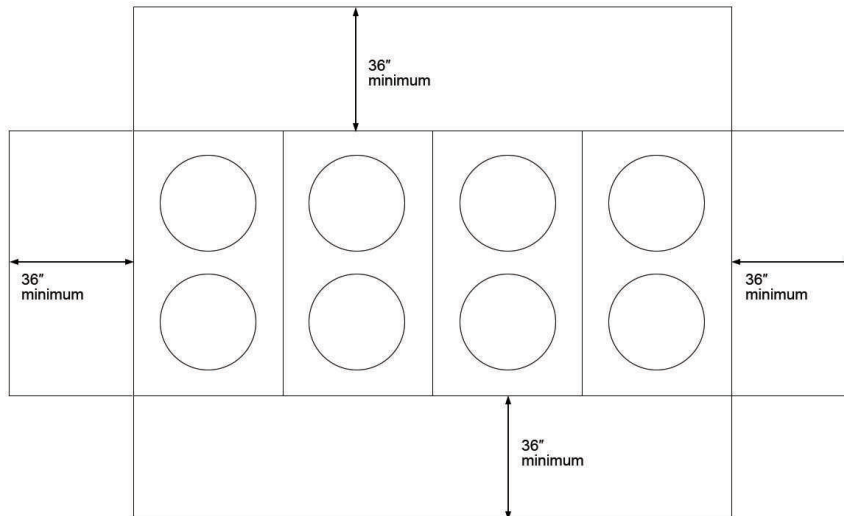

NOTE: If unit is surrounded by a fence, the minimum clearance is 48 inches. The fence must allow 50% airflow.

Note: These clearances are general recommendations. Each installation has specific considerations. Contact Trane for definitive guidance and approval on a job-by-job basis.

Mounting Rails

The chiller must be positioned on a firm, level surface. When modules are installed onto structural steel rails, the rails must be level such that the modules are properly aligned. Mounting rails must be a minimum of 4 inches wide. Custom modules may have different requirements. Consult submittal drawings to confirm dimensions. See [Figure 4, p. 14](#).

After setting and lubricating the mounting rails, begin installing the modules. All of the modules arrive with labels on the electrical and control panel. Review the installation drawings to determine which is the first primary module. Typically, the primary module also has the power distribution panel attached to it.

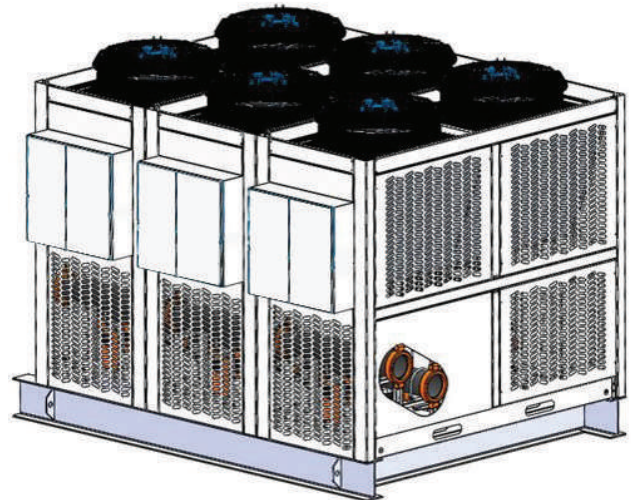
Figure 4. Chiller installation on mounting rails

When installing modules directly on a steel dunnage, spring isolators or rubber-in-shear isolator pads can be installed under the structural steel mounting rails for vibration isolation. After setting each module, remove front or rear access panels to improve access to components when making connections.

When modules are mounted directly on concrete, rubber-in-shear isolator pads can be installed under each module.



A2L Work Procedures

⚠ WARNING

Risk of Fire — Flammable Refrigerant!

Failure to follow instructions below could result in death or serious injury, and equipment damage.

- To be repaired only by trained service personnel.
- Do not puncture refrigerant tubing.
- Dispose of properly in accordance with federal or local regulations.

⚠ WARNING

Refrigerant under High Pressure!

Failure to follow instructions below could result in an explosion which could result in death or serious injury or equipment damage.

System contains refrigerant under high pressure. Recover refrigerant to relieve pressure before opening the system. See unit nameplate for refrigerant type. Do not use non-approved refrigerants, refrigerant substitutes, or refrigerant additives.

⚠ WARNING

Hazardous Voltage!

Failure to disconnect power before servicing could result in death or serious injury.

Disconnect all electric power, including remote disconnects before servicing. Follow proper lockout/tagout procedures to ensure the power can not be inadvertently energized. Verify that no power is present with a voltmeter.

The units described in this manual use R-454B refrigerant. Use ONLY R-454B rated service equipment or components with these units. For specific handling concerns with R-454B, contact your local Trane representative.

Installation, repair, removal, or disposal should be performed by trained service personnel.

At all times, Trane's maintenance and service guidelines shall be followed. If in doubt, contact Trane technical support for assistance.

Serviceing

Prior to initiating work on equipment, check the area with an appropriate refrigerant detector. Ensure the service personnel are properly trained regarding work in potentially toxic or flammable atmospheres. Ensure that the leak detection equipment being used is suitable for use with all applicable refrigerants, i.e. non-sparking, adequately

sealed, or intrinsically safe. Be aware that the refrigerant does not contain an odor.

If any hot work is to be conducted on the refrigerating equipment or any associated parts, appropriate fire extinguishing equipment shall be available on hand. A dry powder or CO₂ fire extinguisher should be located adjacent to the charging area.

At all times, Trane's maintenance and service guidelines shall be followed. In in doubt, contact Trane technical support for assistance.

All maintenance staff and others working in the local area shall be instructed on the nature of the work being carried out. Work in confined spaces shall be avoided.

Ignition Source Mitigation

Do not use any sources of ignition when working on the refrigeration system.

Keep all ignition sources, including cigarette smoking, away from the site of installation, repair, removal or disposal, during which refrigerant can potentially be released to the surrounding space.

Survey the area around the equipment before initiating work to ensure no flammable hazards or ignition risks are present.

"No Smoking" signs shall be displayed.

Do not use devices that can be a source of ignition to accelerate defrosting of components. Use only defrost and cleaning procedures recommended by Trane. Do not pierce or burn.

Ventilation

Ensure that the area is in the open or that it is adequately ventilated before breaking into the system or conducting any hot work. A degree of ventilation shall continue during the period that the work is carried out. The ventilation should safely disperse any released refrigerant and preferably expel it externally into the atmosphere. If present, check that the ventilation system, including outlets, are operating adequately and are not obstructed.

Refrigerating Equipment

Refrigerant piping or components should not be installed in locations where substances which may corrode them are present.

Check that equipment hazard markings are visible and legible. Replace them if they are not.

For equipment using secondary fluids, like water or glycol, check that refrigerant is not present in the secondary fluid loop before conducting any hot work.

Electrical Devices

Do not apply power to the circuit if a fault exists which compromises safety. If the fault cannot be corrected



A2L Work Procedures

immediately, but it is necessary to continue operation, an adequate temporary solution shall be used. This shall be reported to the owner of the equipment, so all parties are advised.

Initial safety checks shall include:

- Cabling is not subject to wear, corrosion, excessive pressure, vibration, sharp edges, or any other adverse environmental effects. Account for the effects of aging or continual vibration from sources such as compressors or fans.
- Capacitors are discharged. This shall be done in a safe manner to avoid possibility of sparking.
- No live electrical components and wiring are exposed while charging, recovering, or purging the system.
- Verify continuity of earth bonding.
- Replace electrical components with Trane replacement parts, or those meeting the same ratings and qualified for flame arrest protection, UL LZGH2 category.

Leak Detection

Never use an open flame to detect leaks. A halide torch should not be used. Use only approved leak detection methods per this instruction manual.

The following leak detection methods are deemed acceptable for all refrigerant systems.

Electronic leak detectors may be used to detect refrigerant leaks but, in the case of flammable refrigerants, the sensitivity may not be adequate, or may need re-calibration. (Detection equipment shall be calibrated in a refrigerant-free area.) Ensure that the detector is not a potential source of ignition and is suitable for the refrigerant used. Leak detection equipment shall be set at a percentage of the LFL gas (25% maximum) is confirmed.

Leak detection fluids are also suitable for use with most refrigerants but the use of detergents containing chlorine shall be avoided as the chlorine may react with the refrigerant and corrode the copper pipe-work.

Examples of leak detection fluids are:

- Bubble method
- Fluorescent method agents

If a leak is suspected, all naked flames shall be removed/ extinguished.

If a refrigerant leak is found which requires brazing, all refrigerant shall be recovered from the system, or isolated (by means of shut off valves) in a part of the system remote from the leak.

Refrigerant Removal and Evacuation

When breaking into the refrigerant circuit to make repairs – or for any other purpose – conventional procedures shall be used. However, for flammable refrigerants it is important

that best practice be followed, since flammability is a consideration.

The following procedure shall be adhered to:

1. Safely remove refrigerant following local and national regulations.
2. Evacuate.
3. Purge the circuit with inert gas.
4. Evacuate (optional for A2L).
5. Continuously flush or purge with inert gas when using flame to open circuit.
6. Open the circuit.

Prior to refrigerant removal, open all appropriate valves, including solenoid and electronic expansion valves (EXVs). Use control settings, where available. When not available, manually open all electronically controlled valves using acceptable service procedures.

The recovery equipment shall be in good working order with instructions available. Equipment shall be suitable for the recovery of the flammable refrigerant. For specific handling concerns, contact the manufacturer. Ensure all hose connections are checked for tightness to avoid refrigerant leaks.

The refrigerant shall be recovered into the correct recovery cylinders if venting is not allowed by local and national codes. Do not mix refrigerants in recovery unit and especially not in cylinders.

Refrigerant recovery unit should be purged with an inert gas after each use or before using with a different refrigerant Class – for example, A2L to A1.

If compressors or compressor oils are to be removed, ensure that they have been evacuated to an acceptable level to make certain that flammable refrigerant does not remain within the lubricant. The compressor body shall not be heated by an open flame or other ignition sources to accelerate this process. When oil is drained from a system, it shall be carried out safely.

The system shall be purged with oxygen-free nitrogen to render the appliance safe for flammable refrigerants. This process might need to be repeated several times. Compressed air or oxygen shall not be used for purging refrigerant systems.

The system shall be vented down to atmospheric pressure to enable work to take place.

The outlet for the vacuum pump shall not be close to any potential ignition sources, and ventilation shall be available.

Refrigerant Charging

In addition to conventional charging procedures, the following requirements shall be followed.

- Ensure that contamination of different refrigerants does not occur when using charging equipment.
- Hoses or lines shall be as short as possible to minimize the amount of refrigerant contained in them.

- Cylinders shall be kept in an appropriate position according to the instructions.
- Ensure that the refrigerating system is earthed prior to charging the system with refrigerant.
- Label the system when charging is complete (if not already).
- Extreme care shall be taken not to overfill the refrigerating system.

Prior to recharging the system, it shall be pressure-tested with the appropriate purging gas. The system shall be leak-tested on completion of charging but prior to commissioning. A follow up leak test shall be carried out prior to leaving the site.

Prior to refrigerant charging, open all appropriate valves, including solenoid and electronic expansion valves (EXVs). Use control settings, where available. When not available, manually open all electronically controlled valves using acceptable service procedures.

Decommissioning

Before carrying out the decommissioning procedure, it is essential that the trained service personnel is completely familiar with the equipment and all its details. It is recommended good practice that all refrigerants are recovered safely. Prior to the task being carried out, an oil and refrigerant sample shall be taken in case analysis is required prior to re-use of recovered refrigerant. It is essential that electrical power is available before the task is commenced.

1. Become familiar with the equipment and its operation.
2. Isolate system electrically.
3. Before attempting the procedure, ensure that:
 - a. Mechanical handling equipment is available, if required, for handling refrigerant cylinders.
 - b. All personal protective equipment is available and being used correctly.
 - c. The recovery process is supervised at all times by a competent person.
 - d. Recovery equipment and cylinders conform to the appropriate standards.
4. Pump down refrigerant system, if possible.
5. If a vacuum is not possible, make a manifold so that refrigerant can be removed from various parts of the system.
6. Make sure that cylinder is situated on the scales before recovery takes place.
7. Start the recovery machine and operate in accordance with instructions.
8. Do not overfill cylinders (no more than 80% volume liquid charge).
9. Do not exceed the maximum working pressure of the cylinder, even temporarily.
10. When the cylinders have been filled correctly and the process completed, make sure that the cylinders and the equipment are removed from site promptly and all isolation valves on the equipment are closed off.
11. Recovered refrigerant shall not be charged into another refrigerating system unless it has been cleaned and checked. When equipment has been decommissioned, attach a signed label which includes the date of decommissioning.
12. When equipment has been decommissioned, attach a signed label which includes the date of decommissioning.



Installation Mechanical

Inspect and Report Damage

Upon receipt, inventory the shipment against the Trane bill of lading to confirm all modules and components have been delivered.

Inspect each package in the shipment for visible damage. Verify the correct model number and that all skids and cartons have been delivered. Any damage must be reported to the motor carrier and Trane within five days of receipt of the shipment.

Inspect all exterior components for concealed damage as soon as possible. Do not proceed with the installation of damaged equipment without prior approval of Trane.

Do not refuse delivery of damaged goods without prior authorization. Unauthorized refusal of the shipment will result in a 20% restocking charge to the customer.

The ownership of the equipment is transferred to the consignee at point of shipment. Refusal of delivery may impede recovery of damages.

It is the consignee's responsibility to accept delivery of damaged goods unless permission to refuse delivery has been granted by Trane.

Inspection of Delivered Equipment

To report damage incurred in transit, complete the following:

1. Inspect each piece of equipment for visible damage before accepting delivery. Check for torn cartons, broken skids, bent metal, and torn shrink wrap.
2. Confirm the delivery driver notes any damage on the bill of lading and completes a Carrier Inspection Report. Failure to comply may result in difficulties in resolving any claims for damage.
3. Inspect each piece of equipment for concealed damage before storage or as soon as possible after delivery.
4. In the event of suspected concealed damage, ask the driver to wait until you inspect the equipment. Concealed damage must be reported within five days of receipt of equipment.
5. If concealed damage is found, stop unpacking the shipment. Do not remove damaged material from the receiving location, take photos of the damage. The owner must provide reasonable evidence that the damage did not occur after delivery.
6. Notify the carrier of the damage as soon as possible. Request an immediate joint inspection by the carrier and consignee. A determination of responsibility will be made, and the carrier will authorize repairs in the event of admission of fault.
7. Notify your local Trane CSO immediately. Trane will coordinate repairs with the owner and carrier. Trane will coordinate repairs with the owner and carrier. Do not attempt to make repairs locally without permission.

Warranty Issues

Trane is not responsible for damages or for filing damage claims. It is the customer's responsibility to confirm that the necessary long-term storage procedures have been completed and any deviations are reported to Trane immediately.

Long Term Storage Requirements

Appropriate preparation and storage of Trane chiller components during extended periods of dormancy is essential to confirm the equipment does not sustain damage or degradation due to inactivity and operates properly after installation.

The customer must notify Trane during the sales process that the chiller system may be transported by ocean freight or placed in long-term storage under any of these conditions:

- The chiller will not be placed into operation for a period exceeding six months after leaving the Trane factory. That is, the initial start-up date will not occur within a six-month maximum dormancy window.
- The chiller will be shipped using ocean transit for all or part of the delivery process.
- Cold temperature storage conditions fall below -20°F (-29°C).
- Ambient temperatures from -20°F (-29°C) to 145°F (63°C) with relative humidity from 0% to 100%.
- The glycol should be removed from the chiller if the unit is to be stored for extended periods.

Factory Preparation

Upon confirmation of an order requiring long-term storage or protection against extreme environments, Trane will inspect and protect vendor-supplied components before installation.

Prior to shipment, Trane will prepare each chiller system for long-term storage in coastal or tropical environments by:

- Placing silica gel packs in all electrical panels and variable speed drive panels to prevent corrosion of electrical contacts and moisture from degrading sensitive controllers.
- Shrink-wrapping each chiller using polyethylene film to limit environmental exposure and protect the chillers from damage during shipping.
- For multiple modular chiller system assemblies shipped on a common skid, shrink wrap the entire skid rather than the individual modules.

Trane will document and photograph the status of the unit prior to shipment and carry out the instructions detailed in

the factory order regarding in-shop preparation of units for long-term storage.

Customer Responsibilities

Upon receipt of a chiller system, the customer must conduct thorough internal and external inspections, removing packaging material as needed for access to all components.

Visible damage must be noted on the signed and dated bill of lading. The customer may request a carrier inspection by telephone or in person, but any such request should be confirmed in writing. It is recommended that the customer request that the carrier inspect the damage within 72 hours of notification.

The customer must store the chiller system in a dry, non-corrosive, dust- and vibration-free environment due to the exposure sensitivities of the microprocessor controllers and to prevent electrical terminations from deteriorating from non-use. Conditions in storage locations should not fall below -20°F (-29°C) or exceed 150°F (66°C).

Components sealed in plastic shrink-wrap are not exempt from these storage requirements. Moisture can potentially collect inside the plastic film, resulting in corrosion of the cabinet and electronic components. Any chiller system packaging that is removed must be replaced with similar protective covering as soon as possible.

Failure to adhere to these long-term storage requirements may void the Trane warranty. Any component that is damaged or inoperable due to improper storage may have its warranty voided.

Handling of the Modules

The packaging from the factory permits lifting with a suitable crane. Confirm straps are in good working condition and that they are rated for the weight of the machines. Spreader bars may be required for effective rigging and to avoid damage to the chiller modules.

The chiller modules arrive fully charged with refrigerant. As required under Federal regulations, installation, start-up, and service should be performed by fully qualified, factory-certified personnel.

⚠ WARNING

Proper Field Wiring and Grounding Required!

Failure to follow code could result in death or serious injury.

All field wiring MUST be performed by qualified personnel. Improperly installed and grounded field wiring poses FIRE and ELECTROCUTION hazards. To avoid these hazards, you MUST follow requirements for field wiring installation and grounding as described in NEC and your local/state/national electrical codes.

⚠ WARNING

Electrical Shock, Explosion, or Arc Flash Hazard!

Failure to follow these instructions could result in death or serious injury.

- **Install the product in an appropriate electrical/fire enclosure per local regulations. Do not install the product in hazardous or classified locations.**
- **Do not use the product for life or safety applications.**
- **Do not exceed the product ratings or maximum limits. Products rated only for basic insulation must be installed on insulated conductors.**
- **Current transformer secondaries (current mode) must be shorted or connected to a burden at all times.**
- **Remove all wire scraps, tools, replace all doors, covers and protective devices before powering the equipment.**

Rigging, Lifting, and Moving the Chiller

The AMC chiller can be delivered to the customer's site as individual modules or with all modules assembled on a common frame. Limitations on the methods and materials that can be used to rig, lift, or move a chiller or an individual module include:

- Maintain the module in an upright position at all times.
- Certain configurations of modules can be top-heavy. Move modules slowly with consideration for each module's center-of-gravity.
- Rig, lift, and move by strapping and lifting using a properly configured floor jack or fork lift or by overhead means.
- Position lifting beams or spreader beams to prevent lifting straps from rubbing or contacting module side panels or electrical boxes. Attach rigging bar on each end of module where 1 3/8-inch holes are provided.
- Do not use cables, chains, or any other type of metalized strapping to lift a module.
- Do not push a chiller module while directly in contact with the floor using manual or mechanical means.



Installation Mechanical

Figure 5. Recommended chiller rigging assembled unit

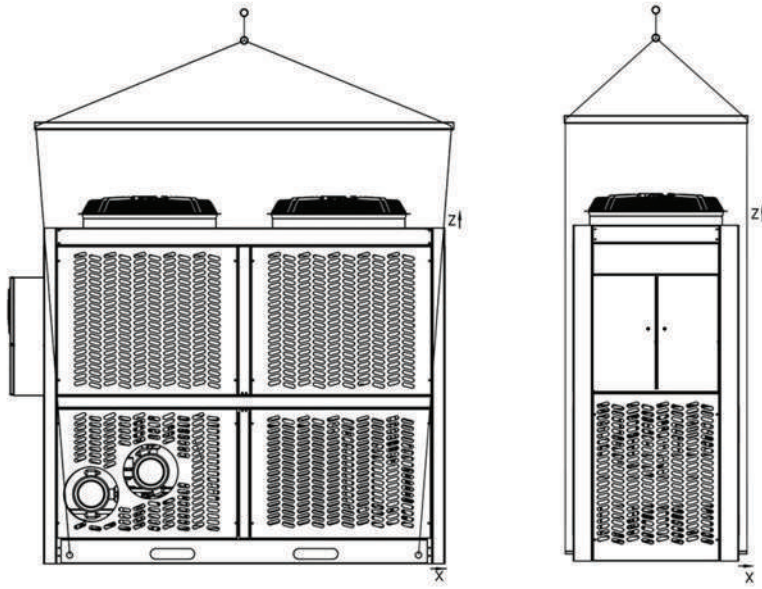

Installation Piping

Install Piping and External Components

Proper support of piping and pipe hangers must consider the weight of the piping as well as the fluid inside the pipes. It is recommended that a minimum of a 30-mesh strainer be installed upstream from the chiller system in the

customer supply inlet piping to prevent fouling of the brazed-plate evaporators. Each chiller evaporator supply piping contains a factory-installed 40-mesh strainer as standard for increased filtration and protection against fouling. The following figure provides a recommended installation of components.

Figure 6. Recommended chiller piping

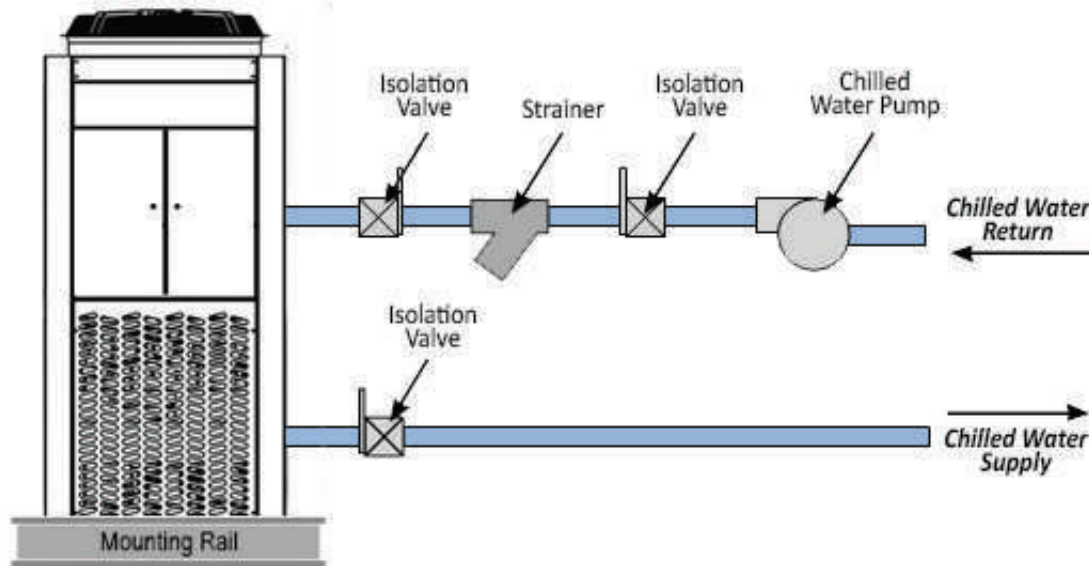

Initial Flushing of Piping

After installation of system piping and before connection to the chiller system, it is important to clean and remove debris, weld slag, and other contamination deposited during fabrication of the piping system.

Typical flushing includes hot water with mild detergent followed by a dilute phosphoric acid solution until all visible residue is removed.

Only cleaning liquids, acids, and detergents compatible with SAE Grade 316 stainless steel, copper, and carbon steel should be used. Consult a professional water treatment specialist when in doubt.

Flushing should take place across a filter/strainer with a maximum 40 mesh screen and continue for a minimum of six hours with frequent removal of the screen to capture residue or until the strainer is clean.

After detergent and chemical cleaning, flush the water piping with fresh water for one hour to remove any remaining cleaning compounds.

Fill with Water/Glycol Solution

The installing contractor is responsible for charging glycol into the chiller hydronic system.

1. Mix the concentrate of propylene glycol in a tank or drum for transfer into the chiller. Use [Table 11, p. 46](#) to determine the appropriate glycol concentration for the chiller.
2. Mix the glycol and water externally before filling the chiller to prevent clogging of the chiller piping with a heavy concentrate.
3. For chiller system with tank and pump module and sealed buffer tank, fill the chiller using the manual fill port on the cabinet. Fill so that the mixture reaches near the top. Stop every so often so the fill level can be monitored.

Note: Do not use the glycol feeder pump to fill the chiller loop. It is not designed for continuous use and will fail.

Only after the above steps have been completed should the water piping be connected to the chiller system.



Installation Piping

Dowfrost

Important: *Dowfrost inhibited propylene glycol-based solution is listed as chemically acceptable by the US Department of Agriculture (USDA). The two ingredients in Dowfrost water/glycol mixture are generally recognized by the FDA as safe food additives under Parts 182 and 184 of the Food Additive Regulations.*

Connecting Module Couplings

Install each module according to its position number indicated on its electrical cabinet. Install the primary module first. Each secondary module has the same installation procedure as the previous module.



Installation Electrical

Connecting Module Power and Control Wires

High voltage power connections are typically made at the power distribution panel located on one end of the chiller

Figure 7. Electrical Supply Connection Location(s)

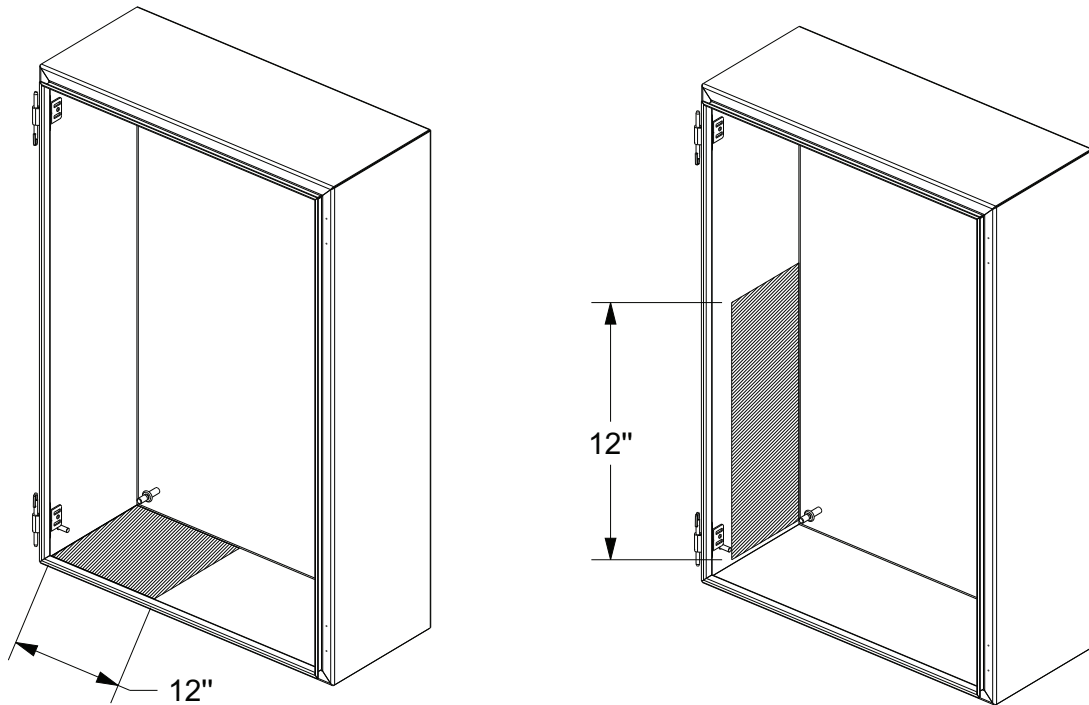

system or individually on each module at the high voltage panel depending on option(s) selected. Connection entries should be made in the lower left corner of the panel(s). See the following figure.

Labeled control and communication cables are coiled inside each module and must be field-connected to an Ethernet switch (if all modules are assembled on an optional common frame, connection to the Ethernet switch is factory provided). The Ethernet cable is routed from the switch to each module's microprocessor controller at the J30 connector.

Each module is equipped with a flow switch. The chiller module will not run unless fluid is circulating through the system and the flow switch closes when flow is detected.

Customer-installed incoming disconnect switches should be designed for all pole disconnection and should be able to trip during overvoltage category III.

⚠ WARNING

Proper Field Wiring and Grounding Required!

Failure to follow code could result in death or serious injury.

All field wiring **MUST** be performed by qualified personnel. Improperly installed and grounded field wiring poses **FIRE** and **ELECTROCUTION** hazards. To avoid these hazards, you **MUST** follow requirements for field wiring installation and grounding as described in **NEC** and your local/state/national electrical codes.

Chiller Module Main Power

Modular systems feature single-point power connection from the utility service to the power distribution panel on the primary module as standard. Main power phases A, B, and C are connected to terminals A, B, and C respectively from left to right. Some custom systems have individual power supplied to each module in lieu of single point power.



Phase Monitor Installation

The chiller is equipped with a phase monitor on the power distribution panel. It is connected to the corresponding input of the primary microprocessor controller. Confirm that the wiring from the primary microprocessor controller and terminal blocks to the phase monitor are connected and secure.

The phase monitor continuously monitors each of the three phases. The microprocessor receives input from the phase monitor indicating whether the voltage is within acceptable values. The phase monitor is designed to protect against under-voltage, voltage imbalance, phase loss, and phase reversal.

Set voltage adjustment knob at the design operating line voltage for the equipment. This adjustment automatically sets the under-voltage trip point.

Important: Do not set the voltage below the design voltage of the chiller.

Check the phase monitor after initial start-up. If it fails to energize, (the LED glows red or blinks) check the wiring of all three phases, voltage, and phase sequence. If phase sequence is incorrect, the LED flashes green/red. To correct this, swap any two line voltage connections at the mounting socket. No further adjustment should be required.

Optional Disconnect Switch

Some chiller systems are optionally equipped with a panel-mounted disconnect switch installed on the outside of the power distribution panel. The disconnect switch must be turned to the off position before the panel can be opened for service.

⚠ WARNING

Hazardous Voltage!

Failure to disconnect power before servicing could result in death or serious injury.

Disconnect all electric power, including remote disconnects before servicing. Follow proper lockout/tagout procedures to ensure the power can not be inadvertently energized. Verify that no power is present with a voltmeter.

Single Point Connections

1. Open the power distribution panel. Power cable holes are accessible from inside module.
2. Remove cable strain relief from back of cabinet. Feed cable end through strain relief.
3. Feed cable end through left most open cable access hole.
4. Push conduit sleeve to engage strain relief. Re-attach strain relief and tighten.
5. Attach and tighten cable ends to its numbered breaker. Each wire is labeled 1, 2, and 3.
6. After installing the cable, attach conduit to a frame member near the coil using a wire tie.
7. Attach ground to lug/bar inside cabinet. Tighten after all grounds have been run.
8. Attach the control wires to the correct module microprocessor. Control wires are in series.
9. Feed control wire through rear of cabinet of the next module control cabinet. Note labels.
10. Connect the Ethernet cable to the J30 port on the microprocessor.

Module Control Wiring

The primary controller communicates with each secondary controller via an Ethernet cable wired to the Ethernet switch which is typically in the primary module.



Operating Principles

This section contains an overview of the operating principles of the Thermafit™ AMC chiller modules design equipped with Carel c.pCO™ controller.

Refrigeration Circuits

Each chiller module has two refrigerant circuits, each with a scroll compressor. Each refrigerant circuit includes compressor suction and discharge service valves, liquid line shutoff valve, sealed filter drier, liquid line sight glass with moisture indicator, charging port, and a thermal (standard) or electronic (with compressor VFD) expansion valve.

Refrigeration Cycle

Each chiller module uses a brazed-plate evaporator. The suction lines are designed to minimize pressure drop. The scroll compressor pressurizes vaporized refrigerant from a low pressure and temperature to high pressure and temperature. De-superheating, condensing, and sub-cooling is accomplished in a fin and tube air-cooled condenser where refrigerant is condensed in the tubes. Refrigerant flowing through the system is balanced by a thermal or electronic expansion valve.

Refrigerant R-454B

Trane believes responsible refrigerant practices are important to the environment, our customers, and the modular chiller industry.

Thermafit™ AMC chiller uses environmentally friendly, class A2L, R-454B refrigerant. R-454B is a zero-ozone depleting, zeotropic, hydrofluoroolefin (HFO) based refrigerant blend. It is designed to serve as direct replacement for R-410A, yet has 78% lower Global Warming Potential (GWP) (466). R-454B has similar capacity and has better efficiency to R-410A.

Compressor and Oil System

Each compressor is hermetic, scroll type, and has constant speed, and there is one on each refrigeration circuit.

An optional variable speed drive is available for use on standard fixed speed compressors and allows capacity modulation from 58% to 100% of the compressor capacity.

Condenser and Fans

Air-cooled condenser coils have aluminum fins mechanically bonded to internally finned seamless copper tubing. Spacing is 16 fins per inch. Copper fins and an epoxy, corrosion-resistant coating are available options for environmentally harsh chiller locations (coastal areas).

The condenser coil has an integral subcooling circuit. Condensers are factory proof tested and leak tested.

Condenser fans are direct-drive, vertical discharge, maintenance free, and have highly efficient Electronically Commutated Motors (ECM). These variable speed fan assemblies varies fan motor RPM to maintain the refrigeration pressure of the chiller modules and allow operation of the chiller down to 0°F ambient.

Evaporator

The evaporator in each module is dual circuit, brazed-plate design, constructed of 316 stainless steel plates and copper brazing. The fluid connections to each evaporator uses roll grooved couplings for service convenience and ease of installation.

Evaporators are insulated with ¾ inch closed cell insulation.

Heat tracing can optionally be provided on the evaporators and all fluid components for freeze protection. A factory installed flow switch is installed on the branch line discharge of the evaporator (typical).

Free-Cooling Operating Modes

The advantage of optional chiller integrated free-cooling is the ability to use outdoor air temperatures to assist in making chilled fluid with or without mechanical cooling. Determining the operating mode depends on four temperatures:

- Ambient air temperature
- Evaporator entering fluid temperature
- Evaporator leaving fluid temperature
- Chilled water setpoint

When the ambient temperature falls to 5°F below the entering fluid temperature, a three-way valve diverts the fluid from the internal header to the free cooling coils. If the free cooling coils do not cool the fluid down to the set point, the fluid continues to the brazed-plate evaporator for further mechanical cooling.

Mechanical Cooling Mode

In this operating mode, the ambient temperature is less than 5°F below or higher than the entering fluid temperature to the chiller. The free-cooling coils are bypassed, compressor(s) are operating, and the fans vary their speed to control head pressure.

Combined Mechanical and Free-Cooling Mode

If the ambient temperature is 5°F or more below the evaporator entering fluid temperature, and free-cooling only cannot satisfy the load, the fluid will continue to flow through free-cooling coils — reducing the evaporator entering fluid temperature — and the compressor(s) will operate to achieve the set point temperature.



Operating Principles

Note: Depending on load, one or both circuits provide mechanical cooling.

Free-Cooling Only Mode

In this operating mode, free-cooling is enabled and is capable of meeting the cooling load without the need for

mechanical cooling. As ambient temperature falls below the temperature at which full load capacity is provided by free-cooling only (or the load drops), fan control modulates fan speed to prevent over-cooling the fluid.

Operating Procedures

Operator Interface

AMC chiller modules, whether they are composed of a single module or up to 12 modules, are automated systems that use a main electrical panel to monitor, report, and modify critical system functions.

Chiller Power Panels

There are two different electrical panels used in AMC chiller. The main power distribution panel receives power from the building source and distributes it to individual modules. The electrical and control panel receives power from the power distribution panel and provides power to the individual electrical components in that module.

Panel-Mounted Disconnect Switch

Some AMC chiller systems are optionally equipped with a panel-mounted disconnect switch installed on the outside of the power distribution panel (or on each module's high voltage electrical if the chiller has power supplied to each individual module). The disconnect switch must be turned to the OFF position before the panel can be opened for service. When the panel door is open, the power is disengaged.

Power Distribution Panels

The power distribution panel receives power from the building source and distributes it to individual modules. It also houses a circuit breaker for each module, a phase monitor, and an optional main power disconnect switch. See following figure.

Figure 8. Power distribution panel

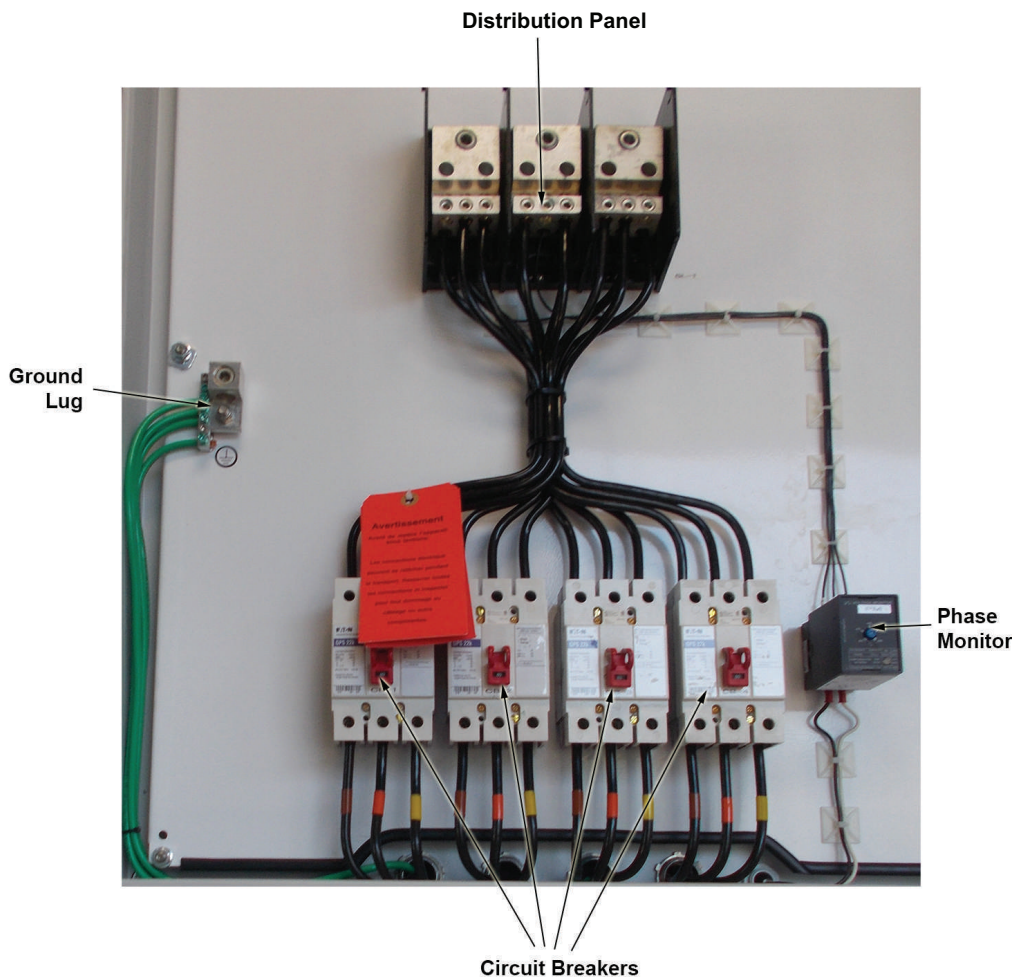

Module Electrical and Control Panel

The electrical and control panel receives power from the power distribution panel and provides power to the individual electrical components in that module. Each

module has its own high voltage electrical panel and low voltage control panel that distributes electricity to individual components. It also has fuses and breakers and microprocessor controller. See the following figure.

Figure 9. Module electrical and control panel

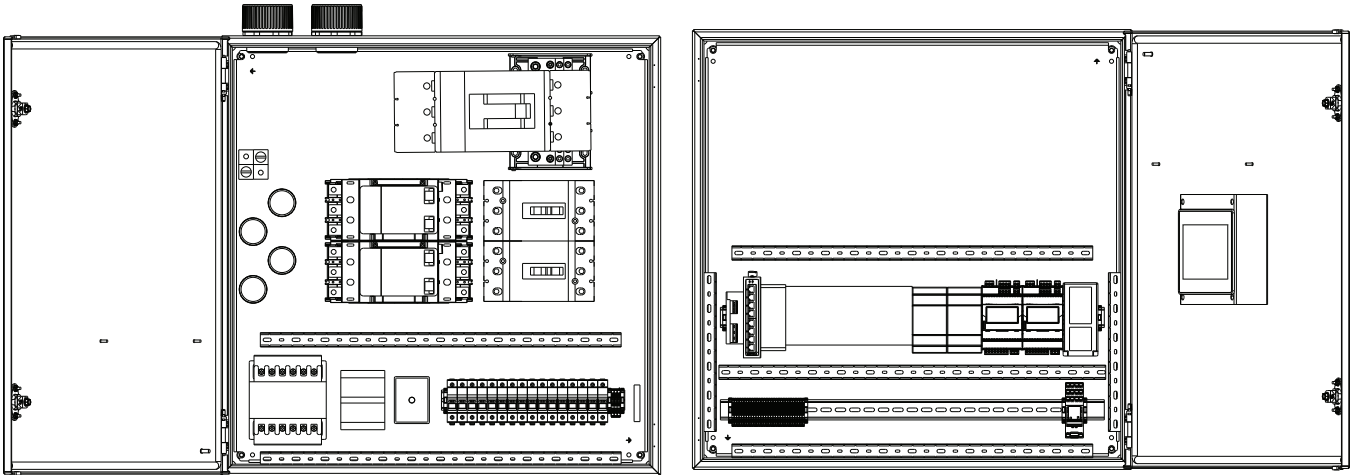

Electronic Control

AMC chiller models use Carel c.pCO series microprocessor controllers to monitor and report critical operating parameters. See Figure 11, p. 28. A main controller is used to control and coordinate the functioning of all the modules that make up the chiller unit. For units consisting of more than a single chiller, each module has its own controller.

modules as needed to maintain the leaving fluid temperature for the chiller.

(See the following figure for a simplified example of a typical microprocessor controller network.)

There are five BMS communication options:

Note: BMS is not included as standard, but available as an option.

1. BACnet® MS/TP - Connection through built-in BMS2 port.
2. BACnet IP - BACnet router is used.
3. Modbus® RTU - Connection through built-in BMS2 port.
4. Modbus IP - Modbus router is used.
5. LonWorks® - LonWorks router is used.

Figure 10. Typical controller network

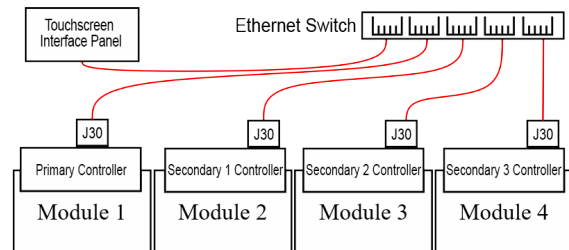
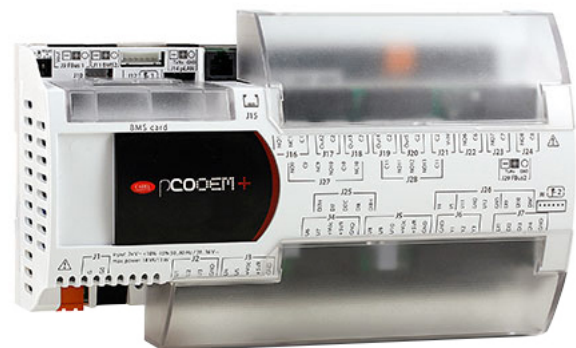

Figure 11. Carel medium c.pCO primary controller



Controllers

The distributed primary microprocessor control system enables all secondary modules to operate independently in the event that the primary microprocessor controller fails. All chiller safeties including temperature set point, refrigerant pressures, and freeze protection are preserved.

In a normal configuration, a secondary controller controls the single module to which it is dedicated.

The secondary controller monitors key performance parameters for its module and sends real-time information to the primary controller. The primary controller monitors the performance of the chiller, activating and deactivating

Operating the Microprocessor

The touchscreen interface panel is ready to use when it is connected to the Ethernet switch and chiller power is ON.

Upon initial start-up, the status line will indicate that the chiller is OFF. Press On/Off button on the home screen to enable System On/Off control pop-up screen. Next, turn chiller on or off manually or switch over to BMS control.

Microprocessor Functions

For practical purposes, all essential control information and operator actions are read and responded to using the touchscreen interface panel. The touchscreen interface panel is connected to the primary microprocessor controller and is the only way to access many primary controller functions.

NOTICE

Component Damage!

Failure to follow instructions could damage sensitive electronic components beyond repair.

To prevent arcing or surges of electrical current, do not use wires or cables to jump components or bypass the manufacturer's safety systems.

Password Protection

There are three levels of access to the functions displayed on the interface. The basic level, 'user,' does not require a password. The higher access levels are the technician ('tech') and administrator ('admin') levels that can only be accessed by Trane technical personnel. Contact Trane technical support regarding the possibility of any potential issues involving the higher-level functions.

Operator Control

A touchscreen interface panel is the primary means for the operator or maintainer to monitor and modify a host of functions involving temperatures, pressures, set points alarms, operating schedules, elapsed operating hours, etc. This touchscreen interface panel can be located within proximity of the primary microprocessor controller. It is typically located in the primary module.

The touchscreen interface is connected to and communicates with all module controllers via the Ethernet switch. It accesses overall chiller functions and settings as well as individual module settings.

In this manual, all functions, procedures, checklists, system information, and changes in system parameters (set points, alarms, primary chiller controls, and so forth) are written

assuming the operator is using the touchscreen interface panel.

When connected to the Ethernet switch, the touchscreen interface panel displays current, real-time, information about the chiller, as well as the status of critical parameters within each module of the chiller.

Touchscreen Interface Panel

The touchscreen interface panel is used to adjust set points, clear alarms, and perform detailed setup of the microprocessor controllers.

The touchscreen interface panel displays information on its touchscreen whenever specific keys and buttons are pressed by the operator. See the following figure.

Basic operator tasks are described in the following sequence of illustrations that comprise a controller tutorial.

Figure 12. Touchscreen interface panel



Touchscreen Interface Tutorial

This section consists of a tutorial that first-time personnel can use to navigate through the various functions and features that are available in the interface.

Each of the main screens in the interface contains active hot spots to activate virtual buttons and switches by simply touching the screen.

Interface Menu Structure

Key interface screens are organized according to system, primary module, and secondary modules functions. See the following figure.

Figure 13. Interface navigation scheme

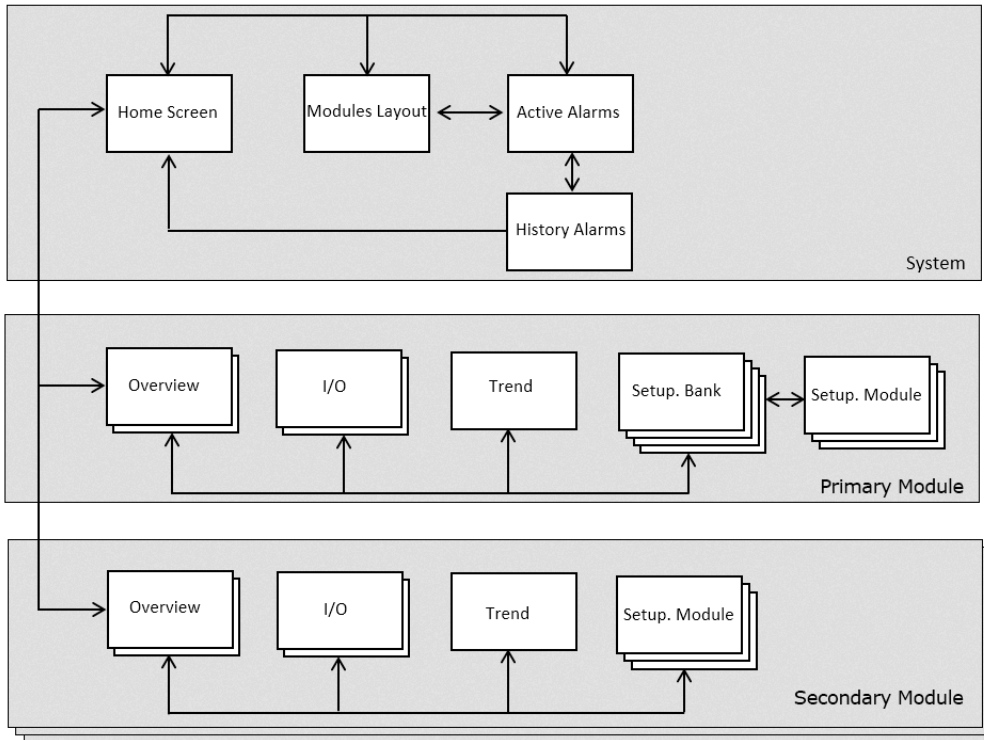

Home Screen Features

Figure 14. HMI home screen

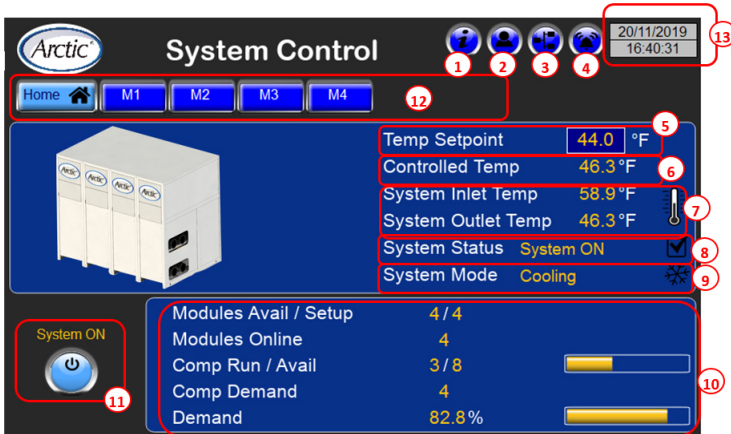

Table 5. Home screen features

Feature	Description
1 - HMI Software Version	<p>Calls up the pop-up window. See the figure below.</p> <ul style="list-style-type: none"> • Project Name: HMI software project name • Software Version: HMI software version • Consists of 4 two-digit numbers <ul style="list-style-type: none"> – First two numbers stand for major and minor software revision. – Third number stands for special software revision. If any project has the special software, this number would be different from '00'. – Fourth number stands for beta software revision. 
2 - HMI User Management / Login	<ul style="list-style-type: none"> • Current User: indicates which user is currently logged in. There are three users for the HMI: user, tech, and admin. <ul style="list-style-type: none"> – User - (default user) has access to viewing data mostly. The only allowed controls for this user are: turning chiller bank on/off and turning compressors on/off (described below). There is no password for this user. – Tech - higher access than user but still limited. Beyond 'user' 'tech' can adjust cooling / heating setpoints, turn separate modules on/off and has access to some machine basic temperature control settings (described below). Password is 'tech2' – Admin - full access to all the settings. • Log in: Calls up user logging screen where user name and password have to be entered. • Log Out: unhidden for 'admin' and 'tech' users only. It logs out from 'admin' or 'tech' user to a default user, which is 'user.' <p>Note: If current user is 'admin' or 'tech' and none of the HMI buttons are pressed for 30 min, it automatically logs out to a default user, which is 'user'. This is the HMI access safety feature.</p> <p>Figure 15. User logging screen</p> 
3 - Module Layout Access	<p>The module layout access button provides fast access to the module layout screen.</p>
4 - Active Alarm Access	<p>The active alarm access button provides fast access to a list of currently active system alarms.</p>

Table 5. Home screen features (continued)



Feature	Description
5 - Setpoint	<p>Calls up cooling/heating setpoint pop-up screens respectively depending on the mode. Accessible for 'tech' only. These dialog boxes display the resulting cooling/heating setpoint used for machine temperature control.</p> <p>Note: <i>The only box on these pop-ups accessible for 'tech' user. The other settings are view-only.</i></p> <p>Figure 16. Cooling setpoint</p>  <p>Figure 17. Heating setpoint</p> 
6 – Controlled Temperature Reading	
7 - System Temperature Sensors Reading	<p>Based on chilled water entering/leaving temperatures for Cooling Mode and hot water temperatures entering/leaving for Heating Mode.</p>
8 – System Status	<p>Possible Options:</p> <ul style="list-style-type: none"> • System ON – System is operational and is not off by any of the conditions listed below. • Phase Alarm – System is off by Phase Alarm. • OFF by DI – System is off by opened state of primary PLC DI1 if corresponding option applies. • OFF by Switch – System is off by software switch. It can be turned on/off either from Home Screen (button marked 11 on Figure 14, p. 30), which all users have access to. It can also be turned on/off from BAS (Building Automation System). • OFF by switching to Cooling – System is off and is switching over to Cooling Mode. • OFF by switching to Heating – System is off and is switching over to Heating Mode. • OFF by switching Mode – System is off and is going through a change of a major parameter. For instance, number of refrigeration circuits, number of fan banks etc. • OFF by Condenser Pumps – System can not run due to disabled Condenser Pumps Module if applicable. • OFF by Evaporator Pumps – System can not run due to disabled Evaporator Pumps Module if applicable. • Free Cooling – System is running Free Cooling. • OFF by Hot Water – System is off by Hot Water cutout. • OFF by BMS – System is off by Building Management System.
9 - System Mode	<p>Indicates chiller thermal mode – Cooling or Heating.</p>
10 – Module/Compressor Status	<ul style="list-style-type: none"> • Modules Online/Avail/Setup – number of modules communicating with Primary Module including Primary Module/available for Primary/Secondary temperature control and number of modules set up for Primary/Secondary temperature control. • Comp Run/Avail – number of compressors currently running and number of compressors available for Primary/Secondary temperature control. • Comp Demand and Demand – Cooling or Heating Demand value in number of requested compressors as well as continuous value in %. There is also a bar graph representation of Cooling or Heating Demand beside the % value.

Table 5. Home screen features (continued)

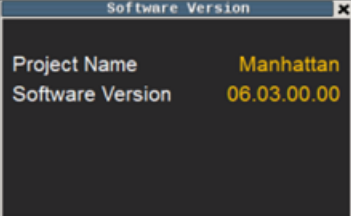
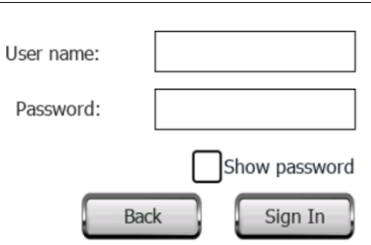
Feature	Description
11 - System ON/OFF	<p>Button that calls up chiller on/off modes popup. The chiller on/off options are as follows:</p> <ul style="list-style-type: none"> • OFF – Turns off chiller bank; • ON – Turns on chiller bank; • BMS – Chiller bank is turned on/off by BMS. 
12 - Module Access	<p>The module access buttons display the overview screen for each module. These buttons provide access to all chiller modules screens individually. The number on the Mx button stands for the module number in the bank. Buttons are viewable (modules accessible) for modules that communicate to HMI only.</p> 
13 - Date/Time	<p>Current HMI date/time as set up in HMI system settings.</p> 

Modules Layout Screen

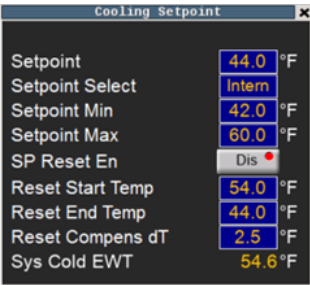
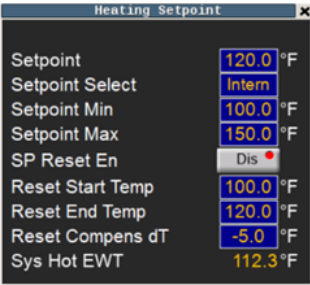
The chiller can be composed of up to a maximum of ten modules. Pressing the LAYOUT button displays the screen showing the status of compressors and valves in each module.

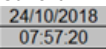
Each module diagram is a set of symbols and colors that show the real-time status of compressors, refrigeration circuit, isolation valves, and overall module. See the following figure.

Figure 18. Modules layout screen showing four compressors on four modules

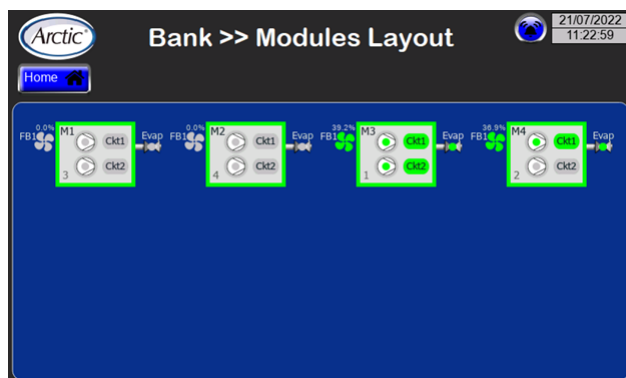

Module Layout Screen Status Conditions

Each module picture is a set of images that show real-time color-coded state of compressor, refrigeration circuit, isolation valves and module.

Table 6. Module status conditions

<p>Module is available</p>	<p>Module is unavailable</p>	<p>Module turned off by alarm and unavailable</p>
<p>Refrigeration circuit in normal state; Compressor ON</p>	<p>Refrigeration circuit is non-operational; Compressor OFF</p>	<p>Refrigeration circuit in alarm state; compressor OFF</p>
<p>Fan bank is running</p>	<p>Fan bank is not running</p>	<p>Fan bank in alarm</p>
<p>Isolation Valves: - Valve LED is green = valve is open - Valve LED is gray = valve is closed</p>	<p>Compressor 1 is OFF; Compressor 2 is ON</p>	<p>Compressor 1 is ON; Compressor 2 is in alarm</p>

Active Alarms Screen



The active alarms screen lists all active (triggered) and non-active alarms in tabular form. See [Figure 19, p. 34](#).

Information presented in this screen in tabular form includes:

- Alarm is 'Active' (Triggered) if 'Source Value' = 1, otherwise it's still active in the PLC.

Figure 19. Active alarms for the chiller

Select	Action	Name	Status	State	Time	
<input type="checkbox"/>		M1 EVD A Alarm	Triggered Not Acked	1	2022/04/06 - 10:06:39 AM	Module 1 EVD Driver A Al
<input type="checkbox"/>		M2 HP Switch CK2	Triggered Not Acked	1	2022/04/06 - 10:05:06 AM	HP2=263.2; Amb=58.4; C

Name

This column gives alarm name.

- Alarm is 'Not Active' (Not Triggered), its 'Source Value' = 0 and it can be reset using Reset button.
- Both 'Active' and 'Not Active' alarms can be acknowledged. When 'Not Active' alarm is acknowledged, it can be reset, which will remove it from the list to show only 'Active' alarms in the list.

Select

This column indicates if the alarm is selected or unselected for acknowledgment or resetting.

Action

This column gives alarm details if applicable.

Status

This column displays the alarm state. There are five possible states for any alarm:

- Triggered Not Acked – Alarm triggered (active) but not acknowledged.
- Triggered Acked – Alarm triggered (still active) and has been acknowledged.
- Not Triggered Not Acked – Alarm no longer appears (inactive) but not acknowledged.
- Not Triggered Acked – Alarm no longer appears (inactive) and acknowledged.
- Not Triggered – Alarm no longer appears (inactive), acknowledged and reset (removed from Active Alarms list).

State

Alarm is considered “Active” (Triggered) if State Value = 1 (still active in the PLC).

If alarm is “Not Active” (Not Triggered), its State Value = 0 (can be reset using Reset button).

Both Active and Non Active alarms can be acknowledged. When a Non Active alarm is acknowledged, it can be reset which will remove it from the list to show only Active alarms in the list.

Description

This column provides alarm description or for certain alarms, snapshots of module parameters values.

Time

This column is the date-time stamp indicating exactly when the alarm occurred.

Check/Uncheck All

This button is used for selecting and deselecting all listed alarms with a single action.



Ack

Pressing this button acknowledges the alarm and removes it from the active alarms list.

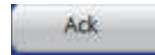

Save

Pressing this button saves the changes made to the active alarms list. Any changes that are made without saving will be lost.

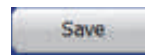

Reset PLC

This button is used to reset Active alarms in the PLC, so they could be further acknowledged/reset on the HMI.

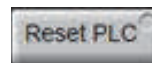

Alarm History

On the active alarms screen, pressing the alarm history button displays the alarm history screen



The alarm history screen displays the history of alarms recorded by the primary microprocessor. See [Figure 20, p. 36](#).

Figure 20. Alarm history



Sorting

Alarm history list can be sorted by any column in ascending or descending order by tapping the corresponding column heading. The triangle that appears next to the heading indicates which column is being sorted and the direction of sorting.

Sorting is applied to the alarm time column in ascending order by default, which is indicated when the triangle is pointing up. Ascending order for the alarm time column requires that earlier records appear on the list first. For all other columns, alphabetical sorting applies.

History Alarms CSV Export generates history alarms log as CSV file that can be stored.

Duration

Allows selecting the time period for which the alarm history is displayed. Once the selection is made from the drop-down menu, pressing the REFRESH button updates the list and then **From** and **To** timestamps get updated accordingly.

Time

This is the time stamp that is displayed when the alarm state was changed.

Name

This column gives alarm name.

Status

This column displays the alarm state. There are five possible states for any alarm:

- Triggered Not Acked – Alarm triggered (active) but not acknowledged
- Triggered Acked – Alarm triggered (still active) and has been acknowledged

- Not Triggered Not Acked – Alarm no longer appears (inactive) but not acknowledged
- Not Triggered Acked – Alarm no longer appears (inactive) and acknowledged
- Not Triggered – Alarm no longer appears (inactive), acknowledged, and reset (removed from Active Alarms list)

State

Alarm is Active (Triggered) if State Value = 1 (still active in the PLC)

Alarm is Not Active (Not Triggered) if State Value = 0 (can be reset using Reset button)

Both Active and Non Active alarms can be acknowledged. When a Non Active alarm is acknowledged, it can be reset which will remove it from the list to show only Active alarms in the list.

Description

This column provides alarm description or for certain alarms, snapshots of module parameters values.

Alarms Filtering

State Filter applies to Alarm State.



Alarm State '0' – Alarm is inactive.

Alarm State '1' – Alarm is active (even if it has been acknowledged).

When Show Active Alarms is selected from the State Filter drop-down list, inactive alarms (State = '0') will be hidden on the list, and only active alarms (State = "1") will appear.

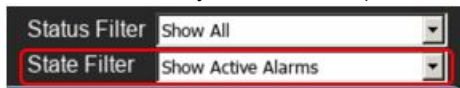

For example: High Pressure switch alarm records *before* filter is applied.

Time	Name	Status	State	Des
2021/11/15 - 09:22:20 AM	M1 HP Switch Ckt1	Not Triggered	0	HP1=189.1; Amb=78.8; CEWT=0.0; CLWT
2021/11/15 - 09:22:05 AM	M1 HP Switch Ckt1	Not Triggered Acked	0	HP1=189.1; Amb=78.8; CEWT=0.0; CLWT
2021/11/15 - 09:21:56 AM	M1 HP Switch Ckt1	Triggered Acked	1	HP1=189.1; Amb=78.8; CEWT=0.0; CLWT
2021/11/15 - 09:21:48 AM	M1 HP Switch Ckt1	Triggered Not Acked	1	HP1=189.1; Amb=78.8; CEWT=0.0; CLWT

High Pressure switch alarm records *after* filter is applied.

Time	Name	Status	State	Des
2021/11/15 - 09:21:56 AM	M1 HP Switch Ckt1	Triggered Acked	1	HP1=189.1; Amb=78.8; CEWT=0.0; CLWT
2021/11/15 - 09:21:48 AM	M1 HP Switch Ckt1	Triggered Not Acked	1	HP1=189.1; Amb=78.8; CEWT=0.0; CLWT

Status Filter applies to Alarm Status.



When Show Alarm Event is selected from the Status Filter drop-down list, any non-alarm events pertaining to user action (acknowledgement and reset) is filtered off the list. Only alarm-related events appear.



For example: High Pressure switch alarm records *before* filter is applied.

Time	Name	Status	State	Des
2021/11/15 - 09:22:20 AM	M1 HP Switch Ckt1	Not Triggered	0	HP1=189.1; Amb=78.8; CEWT=0.0; CLWT
2021/11/15 - 09:22:05 AM	M1 HP Switch Ckt1	Not Triggered Acked	0	HP1=189.1; Amb=78.8; CEWT=0.0; CLWT
2021/11/15 - 09:21:56 AM	M1 HP Switch Ckt1	Triggered Acked	1	HP1=189.1; Amb=78.8; CEWT=0.0; CLWT
2021/11/15 - 09:21:48 AM	M1 HP Switch Ckt1	Triggered Not Acked	1	HP1=189.1; Amb=78.8; CEWT=0.0; CLWT

High Pressure switch alarm records *after* filter is applied.

Time	Name	Status	State	Des
2021/11/15 - 09:22:05 AM	M1 HP Switch Ckt1	Not Triggered Acked	0	HP1=189.1; Amb=78.8; CEWT=0.0; CLWT
2021/11/15 - 09:21:48 AM	M1 HP Switch Ckt1	Triggered Not Acked	1	HP1=189.1; Amb=78.8; CEWT=0.0; CLWT

Any alarm events pertaining to user action (acknowledgement and reset) is filtered off the list.

Combining both **State Filter** and **Status Filter** can enhance alarms viewing even more.

For instance, one needs to view only events when alarms occurred and hide all other ones (aka one alarm event for each alarm).

For example: Alarms record *before* filters are applied.

Time	Name	Status	State	Des
2021/11/15 - 09:22:20 AM	M1 HP Switch Ckt1	Not Triggered	0	HP1=189.1; Amb=78.8; CEWT=0.0; CLWT
2021/11/15 - 09:22:05 AM	M1 HP Switch Ckt1	Not Triggered Acked	0	HP1=189.1; Amb=78.8; CEWT=0.0; CLWT
2021/11/15 - 09:21:56 AM	M1 HP Switch Ckt1	Triggered Acked	1	HP1=189.1; Amb=78.8; CEWT=0.0; CLWT
2021/11/15 - 09:21:48 AM	M1 HP Switch Ckt1	Triggered Not Acked	1	HP1=189.1; Amb=78.8; CEWT=0.0; CLWT
2021/11/15 - 09:21:03 AM	M1 Evap LWT High	Triggered Not Acked	1	Module 1 Evap LWT High Alarm
2021/11/15 - 09:05:23 AM	M4 LP Lockout Ckt1	Not Triggered	0	Module 4 LP Lockout Ckt1 Alarm
2021/11/15 - 09:05:23 AM	M4 LP Ckt1	Not Triggered	0	LP1=115.0; EXV=0.0; SSH1=0.0; EEW

Alarms record *after* filters are applied.

Time	Name	Status	State	Des
2021/11/15 - 09:21:48 AM	M1 HP Switch Ckt1	Triggered Not Acked	1	HP1=189.1; Amb=78.8; CEWT=0.0; CLWT
2021/11/15 - 09:21:03 AM	M1 Evap LWT High	Triggered Not Acked	1	Module 1 Evap LWT High Alarm

Module Access

Buttons to access all modules screens individually. Number on the button "M(X)" stands for the module number in the bank. Buttons are viewable (modules accessible) for modules that communicate to HMI only. Each module menu includes the following set of screens.

- Overview - overview of main chiller module refrigeration parameters and status of its components – refrigeration circuit, heat exchangers, compressors, and module itself.
- I/O - state and description of module PLC digital/analog inputs and outputs including expansion IO (Inputs Outputs) module.
- Trend - trending curves for Cooling or Heating Demand are displayed.
- Setup - setup screens contain all the chiller settings applied to system and is available for primary module as well as module settings. All setup screens are available for 'admin' user only.

Overview Module Screens

Each module controlled by the microprocessor controller has its own module screen within which the operator can monitor and maintain conditions affecting that module. Primary module access is made through the system control screen containing multiple controls and indicators:

On the home screen, pressing the **M1** button displays the Module #1 (primary module) overview 1 screen.

The overview menu is comprised of two screens:

Overview Module (primary and secondary) and Overview Circuits. Use the left and right scrolling buttons to scroll through the overview screens.



Table 7. The overview screens

<p>Primary Overview Module Screen</p>	<p>Secondary Overview Module Screen</p>
<p>Primary/Secondary Overview Circuit Screen</p>	

Overview Module

Module En/Dis

Pressing this button enables or disables a module. It is used for testing and maintenance purposes. If module is disabled, it is excluded from primary control compressors sequence. Not accessible for 'user'.

Module Status

Possible options:

- Module ON - Module is ready to run.
- OFF by DI - Module is off by opened state of PLC DI1.
- OFF by Switch - Module is off by Module En/Dis button.
- OFF by Alarm - Module is locked out by one of the major alarms.
- OFF by Primary - Module is switching between control states Primary/Secondary/Stand-alone.
- OFF by System - Module is off by one of the System Off conditions.
- OFF by switching to Cooling - Module is switching over to Cooling Mode.

- OFF by switching to Heating - Module is switching over to Heating Mode.
- OFF by switching Mode - Module is off and is going through a change of a major parameter. For instance, number of refrigeration circuits, number of fan banks etc.
- Free Cooling - Module is running in Free Cooling Mode.
- Refrigeration Evacuation Cycle - Module is running Refrigeration Evacuation Cycle.
- Cooling Limited - Cooling restricted on Heat Recovery units.

Module Cntrl Status

Possible options:

- Primary - Module acts as a primary module. Primary module performs temperature control for either heating or cooling loads. It also acts as a Supervisor when communicating with secondary modules and defines how many modules need to run its compressors in order to satisfy heating or cooling controlled temperatures.

- Secondary - Module acts as a secondary module. Conditions for the module to be a secondary module:
 - Its PLC has been assigned IP address from secondaries addresses range.
 - It is communicating with primary module.
 - Primary module exists on the network, in other words Primary PLC meets primary module conditions (see “Primary Status,” p. 39).
 - Stand-alone. Module does not meet either primary module or secondary module conditions.

Primary Status

Applies to primary PLC only. Possible options:

- Primary ON - All primary modules conditions are satisfied by module.
- Waiting - All primary modules conditions are satisfied and module is counting down a delay before acquiring primary ON status.
- OFF by Sensor - System cooling or heating temperature sensor failed.
- OFF by no secondary - Primary PLC communicates with no secondary modules.

Note: Master Status states 3 or 4 will cause all the modules to run in Stand-alone mode. These failing conditions are false at normal primary/secondary operation.

Primary Online

Applies to secondary PLC only. Possible options:

- LED is green - secondary PLC is communicating with primary PLC.
- LED is gray - secondary PLC is not communicating with primary PLC.

Lead Module

Indicates which module is currently a lead module in the bank.

Evap/Cond Circuits

Displays Evaporator inlet and outlet temperatures and an opening status of Evaporator Isolation Valves as well as Ambient Temperature.

Local Temp Cntrl

Applies only if module is running in stand-alone mode.

- Temp Cool/Heat - Local module hot or chilled water temperature control sensor.
- Temp SP Cool/Heat - Local module heating or cooling temperature control setpoint. Can be adjusted by **tech** user only.
- Cool/Heat Comps Demand - Cooling or Heating Demand value in number of requested compressors.

Temp Cntrl Settings

Viewable/adjustable for 'tech' user only.

- Cool Temp Diff +/- - Temperature control differential above/below setpoint or positive/negative dead band (DB) in Cooling Mode.
- Heat Temp Diff +/- - Temperature control differential below/above setpoint or positive/negative dead band (DB) in Heating Mode.

Note: Both of them define the temperature control DB.

- Cool St Up/Dwn Dly - When next compressor has been staged up/down, this delay has to elapse before next compressor is allowed to stage up/down in Cooling Mode.
- Heat St Up/Dwn Dly - When next compressor has been staged up/down, this delay has to elapse before next compressor is allowed to stage up/down in Heating Mode.

On/Off Button

Used to turn secondary PLC module on/off in Stand-alone Mode. For primary PLC module, On/Off Button on the Home Screen serves the same purpose.

Overview Circuits

Refrigerant temperatures/pressures are displayed: suction pressure; discharge pressure; suction temperature; suction super heat temperature.

Suct/Disch Pres and Suct/SH Temp

Refrigerant temperatures and pressures are displayed: suction pressure, discharge pressure, suction temperature, and suction super heat temperature.

Liq Line Solenoid

Status of the solenoid valve installed on the liquid line pipe.

EX Valve

Indicates the position of electronic expansion valve, if installed.

Comp (X) En/Dis

Compressor enable/disable button.

Evac Cycle

Enable/disable evacuation cycle for the circuit – Available for 'tech' user only.

Comp (X) Status

- Comp OFF - Compressor is off and cannot be turned on.
- Ready - Compressor is off but can be turned on.
- OFF by Cond Flow - Compressor has been called to run but waiting for Condenser Flow proof
- OFF by Evap Flow - Compressor has been called to run but waiting for Evaporator Flow proof.
- OFF by Min Off - Compressor is cycling through safety Minimum Off Time.
- OFF by Switch - Compressor is off by En/Dis Switch.

Operating Procedures

- OFF by Alarm - Compressor is off by Alarm.
- Running - Compressor is running.
- ON by Min On - Compressor has been called off although it keeps running due to safety Minimum On Time.
- ON by Pumpdown - Compressor has been called off but keeps running due to pumpdown sequence.
- Start Delayed - Waiting for EXV positioning (if applicable) or going through second compressor start-up delay.
- OFF by Restriction – Module capacity restricted to a single running compressor only due to Low Chilled Leaving Water Temperature.
- Min Speed Sequence - Variable speed compressor is going through Variable Speed Drive Minimum Speed sequence (SuperMod only).
- OFF by Min DP - Compressor is off due to inability to build up satisfactory Suction/Discharge differential pressure.
- OFF by Low Ambient - Compressor can not start due to Low Ambient temperature restriction.
- Refrigeration Evacuation Cycle - Circuit is running Refrigeration Evacuation Cycle.

Comp (X) Speed

Can be displayed in different units.

- Volts – If PLC analog output is used to control variable speed compressor.
- RPM – Compressor speed is communicated to external variable speed drive, for instance VFD.

Module I/O Screens

Data is collected by sensors as either analog or digital signals and displayed on the IO Status screens.

When the module screen is displayed, pressing the I/O button displays the I/O menu.

The I/O menu is comprised of three screens. Both primary and secondary modules have analog I/O (analog input and analog output), and digital I/O (digital input and digital output). The third screen, expansion I/O, only applies to the primary module.

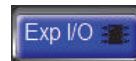
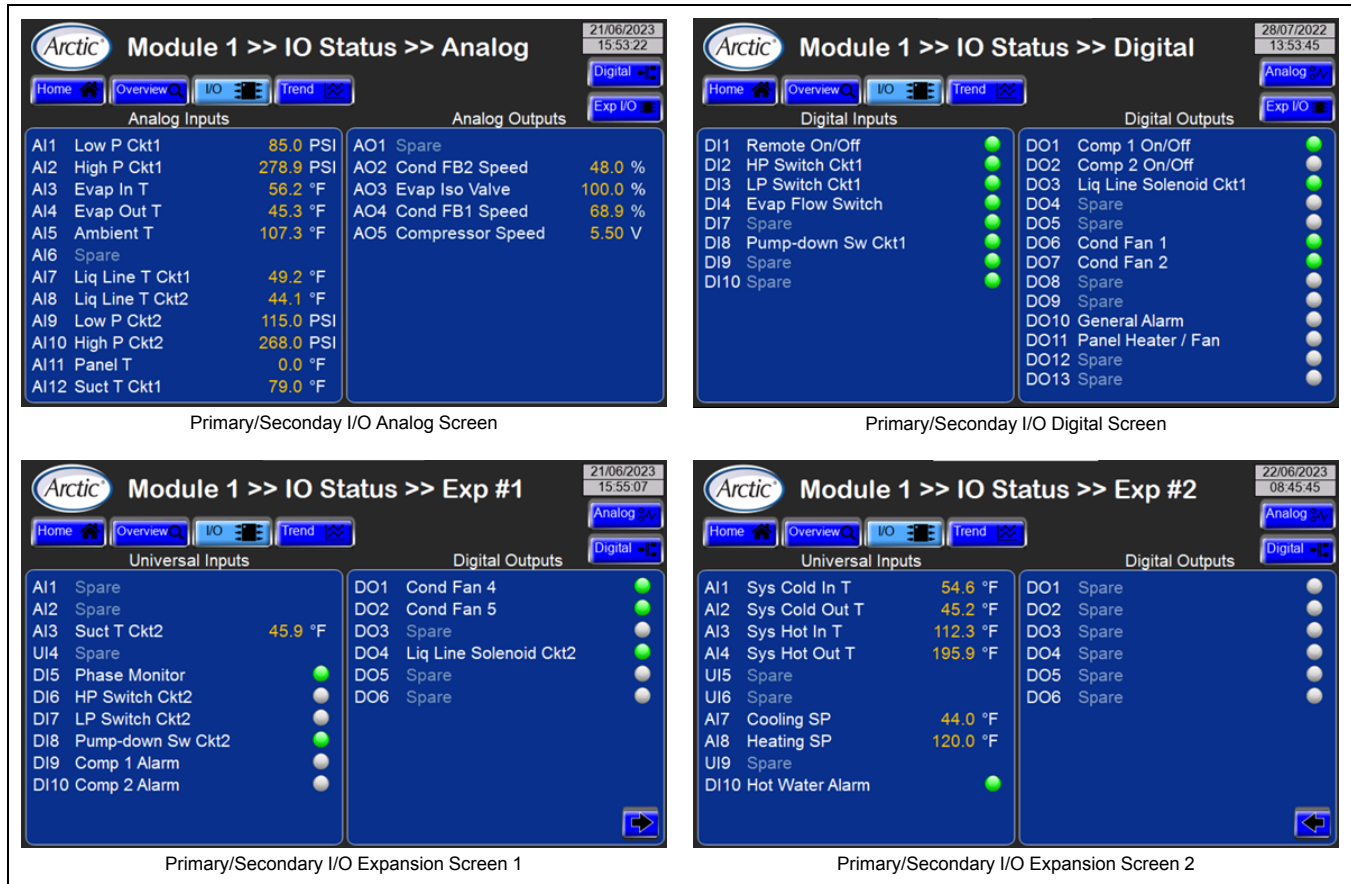

Table 8. Analog and digital input/output screens



When an I/O screen is displayed, switching to other I/O screens is accomplished by pressing their respective buttons:

- The ANALOG button displays the analog screen.
- The DIGITAL button displays the digital screen.

Digital LEDs

There is an LED for each input that indicates its current state. For all inputs, the color of the LED signifies its current state:

- Green LED – This input is energized, the connected device is closed.
- Gray LED – This input is de-energized, the connected device is open.



Analog Inputs



Analog input (AI) data includes these parameters:

AI1

This input indicates suction pressure.

AI2

This input indicates discharge pressure.

AI3, AI4

These inputs indicate the evaporator inlet or outlet temperatures.

AI5

This input indicates ambient temperature.

AI6

This input indicates free-cooling controlled temperature.

AI7, AI8

These inputs indicate Liquid Line Temperature for Circuit 1/2.

AI9, AI10

These inputs indicate Suction/Discharge Pressure Circuit 2.

AI11

This input indicates Panel Temperature (optional). It is used when temperature control inside control panel is required either heating (for cold environment) or cooling (for hot environment).

AI12

This input indicates Suction Temperature Circuit 1.

Analog Outputs

Analog output (AO) data includes these parameters:

AO2

This output indicates the variable speed of Fan Bank 2 (if applicable).

AO3

This output indicates the evaporator's isolation valve position.

AO4

This output indicates the variable speed of Fan Bank 1.

AO5

This output indicates the variable speed compressor's hard-wired control signal.

Digital Inputs

Digital input (DI) data includes these parameters:

DI1

Remote On/Off – Used to turn module on/off via input. For Primary Module toggling, DI1 will turn on/off the entire chiller if respective option selected.

DI2, DI3

These inputs indicate the Discharge/Suction Pressure switches of Circuit 1. DI closed - pressure is in the normal range; DI opened - pressure is exceeding normal range threshold (faulty state).

DI4

This input indicates the state of Evaporator flow switch. DI closed - flow present; DI opened - flow absent.

DI8

This input indicates the pump-down pressure switch of Circuit 1. DI closed – pressure is in the normal range; DI opened – pressure is exceeding normal range threshold (faulty state).

Digital Outputs

There is an LED for each digital output which shows its current state.

DO1, DO2

Comp On/Off – these output turns a compressor on and off.

DO3

Liq Line Solenoid – this output energizes and de-energizes the liquid line solenoid valve.

DO4

Free Cooling Valve – this output energizes/deenergizes Free Cooling diverting valve. When Free Cooling is active, this valve is utilized to direct Evaporator Flow via Free Cooling Condenser coils that maintain System Chilled Water Temperature in Free Cooling Mode.

DO6-DO8

Fans 1, 2, 3 – this output is used to turn fans of Fan Bank 1 on and off.

DO10

General Alarm – this output energizes when any of the following alarms occur:

- An alarm that shuts down and locks out compressor 1 or 2.
- An alarm that shuts down and locks out the entire module.

DO11

Panel Heater/Fan (optional) – this output is used when temperature control inside control panel is required.

Expansion IO Screen 1

This screen is applicable to the primary and secondary module. This screen controls analog inputs and digital requests.

AI3

This input indicates Suction Temperature Circuit 2.

DI5

Phase Monitor - This input indicates chiller three-phase power supply protection module feedback. DI closed – No power supply issues. DI opened – Power supply failure detected.

If common power supply protection module is used for the chiller, its failure affects each module. In such a scenario, this DI is optional for Secondary module.

DI6, DI7

These inputs show the Discharge/Suction Pressure switches of Circuit 2. DI closed – pressure is in the normal range; DI opened – pressure is exceeding normal range threshold (faulty state).

DI8

This input shows Pump-down pressure switch of Circuit 2. DI closed – pressure is in the normal range; DI opened – pressure is exceeding normal range threshold (faulty state).

DI9

This input shows the Compressor 1 External Alarm. DI closed – no alarm. DI open – compressor in alarm.

DI10

This input shows the Compressor 2 External Alarm.

DO4

This output energizes and de-energizes the liquid line solenoid valve circuit 2.

DO1, DO2, DO6

Fans 1, 2, 3 – Used to command on/off fans of Fan Bank 2.

Expansion IO Screen 2

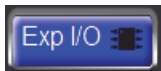

This screen is only applicable to the primary module. This screen controls analog inputs and digital requests.

AI1, AI2

These inputs indicate the system chilled entering/leaving water temperature — applies to Cooling Mode.

AI3, AI4

These inputs indicate System Hot Entering/Leaving Water Temperature — applies to Heating Mode.

AI7, DI8

These inputs indicate the remote cooling/heating setpoint.

DI10

Hot Water Cutout – shuts down the whole chiller bank if hot water temperature becomes too high.

Trend Screen

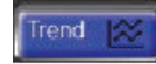

When on the primary module screen, pressing the trend button displays the trend screen. There are two trend screens: cooling and heating.

Each trend screen displays three trends: Controlled Inlet Water Temperature, Controlled Outlet Water Temperature, and Module Demand in %.

Trends can be viewed in real time and for the last two days. Each variable is trended every 3 seconds. Trending data is stored on HMI internal memory.

Figure 21. Module trend screen



Apart from displaying trends, Module Trend Screen has controls for viewing, scrolling, zooming, deleting trends etc.

Table 9. Trend screen labels

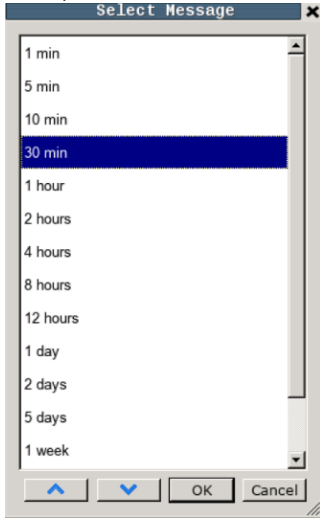
Label	Description
1	According to where the cursor is placed, it is capturing real time values of in and out water temperatures. Current cursor timestamps are displayed as well.
2	Text box to select viewing time span. It is used for zooming in on trends time axis. Options for selection: 
3	Maximum and Minimum thresholds for trends viewing. Used for zooming in on trends variables axis. Both Maximum and Minimum thresholds are adjustable via respective numeric boxes. Default Min/Max values: -10.0/160.0. Default Span button is used to revert to defaults to reset longitudinal zooming.
4	Scroll to Time button is used to return to real time viewing.
5	Cursor positioning buttons.
6	Buttons used to scroll back and forth in time. They implement time axis trends pages scrolling.
7	Buttons used to scroll back and forth in time. High resolution time axis scrolling.
8	Button used to pause/resume real-time trending.

Setup Screen

Note: Available for 'tech' user only.

When on Overview Module screen, press Setup button to go to BMS Communication Setup screen.



Figure 22. BMS communication setup screen

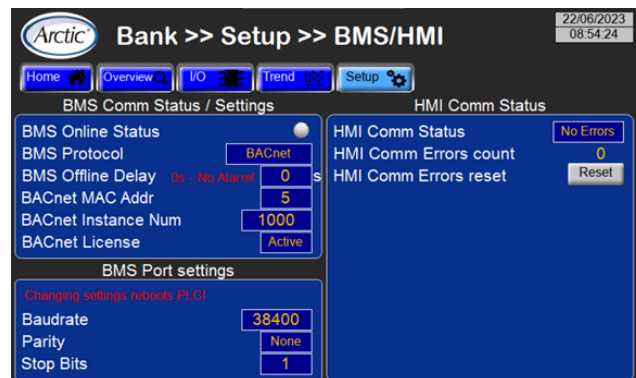

Features	Description
BMS Online Status	Indicates whether BMS is communicating to chiller bank or not.
BMS Protocol	Allows to select BMS communication type. The options are: <ul style="list-style-type: none"> None – BMS communication disabled. BACnet – BACnet MSTP or BACnet IP BMS communication used. Modbus/Lon – Modbus RTU, Modbus IP or LonWorks BMS communication used. <p>Note: BACnet IP, Modbus IP or LonWorks require a use of external router/gateway to implement communication channel.</p>
BMS Offline Delay	If BMS is not communicating to chiller bank for longer than this delay, BMS communication alarm is raised. If setting = 0, BMS communication alarm is disabled.
BACnet MAC Addr	Chiller BACnet MAC address for BACnet MSTP BMS communication.
BACnet Instance Num	Chiller BACnet Instance Number for BACnet MSTP or BACnet IP BMS communication.
BACnet License	Indicates if BACnet license has been activated on the chiller. <p>Note: BACnet license has to be activated on chiller bank Primary PLC in order to enable BACnet IP or BACnet MSTP BMS communication.</p>
Baudrate	BMS communication speed in bits/second
Parity	BMS communication frames parity. The options are: <ul style="list-style-type: none"> None Odd Even
Stop Bits	Number of BMS communication frames stop bits: 1 or 2.
HMI Comm Status	No Errors – HMI communicating to module PLCs with no errors. Comm Error – at least a single communication error occurred.
HMI Comm Errors count	Number of occurred HMI communication errors.
HMI Comm Errors reset	Resets number of communication errors to '0'.

Operator Tasks

Before operating the unit, confirm all compressor refrigeration service valves are fully back-seated counterclockwise.

NOTICE

Compressor Failure!

Failure to properly back-seat rotalock valves can cause compressor failure.

Verify the circuit breakers on the module electrical panel are turned to OFF position prior to applying power.

Normal Power Up

The following procedure is used for a start-up resulting from scheduled seasonal or programmed cold shut down of the chiller.

⚠ WARNING

Hazardous Voltage!

Failure to disconnect power before servicing could result in death or serious injury.

Disconnect all electric power, including remote disconnects before servicing. Follow proper lockout/tagout procedures to ensure the power can not be inadvertently energized. Verify that no power is present with a voltmeter.

Important: This start-up procedure is not to be used for the first-time initial start-up for a newly installed chiller. See Preparation for Initial Start-up in the Installation section of this manual for instructions regarding that situation.

1. De-energize the chiller using standard lockout/tagout procedures.
2. Using a known operational voltage meter, test and confirm the chiller is de-energized before proceeding further.
3. Inspect power distribution fuses and overload settings to verify they are correct.
4. Verify that the oil level is correct in each compressor using the compressor sight glass.

Note: See recommended inspection interval in the maintenance section of this manual.

NOTICE

Compressor Failure!

Failure to follow instructions below could result in catastrophic compressor failure.

Do not operate with insufficient oil.

5. Verify that pressure and temperature switches are closed.
6. Restore power to all modules.
7. Inspect refrigerant pressures for each module using the touchscreen interface panel.
8. Verify that pressure switches and thermostats have the correct cut-in and cut-out settings using the touchscreen interface panel.
9. Verify chiller water flow to condenser and evaporator.
10. Monitor and record temperature and refrigerant pressures registering on the touchscreen interface panel.

Emergency Power Shutdown

The chiller does not include a disconnect to turn off the high voltage to the modules. As per NFPA 70, The National



Operating Procedures

Electrical Code, a disconnect must be installed within the line of sight of the electrical and control panel. Should an emergency condition arise, the disconnect must be opened to shut down all voltage to the chiller.

There are several ways to interrupt power to all or part of the chiller:

- Disconnect the primary power source from the building that feeds electricity to the chiller. This occurs in sudden emergencies (usually weather-related) or planned maintenance shut-downs.
- Press the panel disconnect switch on the exterior door of the chiller's main power distribution panel, if so equipped.
- Move the circuit breaker switch to the OFF position (CB-1 and CB-2) on the power distribution panel. This cuts power to all of the chiller modules.
- Move the circuit breaker switch to the OFF position (CB-1 and CB-2) on a module's electrical and control panel. This cuts power to the compressors in a single module. It does not cut power to electrical and control panel or other chiller modules.
- Press the SYSTEM ON button on the touchscreen interface panel that is built into the power distribution panel door.

Note: Pressing the ON-OFF button on the touchscreen interface panel does not de-energize the chiller or the high voltage current into each module's electrical and control panel. This action sends a command to the controller in each module's compressors to discontinue electrical current to that component.

Water Quality Guidelines

The chiller is equipped with high efficiency compact brazed-plate heat exchangers (BPHE). Water quality must be maintained periodically by the end user to avoid scaling and corrosion inside the heat exchangers.

Table 10. Water quality guidelines

Element/Compound/Property	Value/Unit
pH	7.5 - 9.0
Conductivity	<500 μ S/cm
Total Hardness	4.5 - 8.5 dH°
Free Chlorine	<1.0 ppm
Ammonia (NH ₃)	<0.5 ppm

Table 11. Glycol performance impact factors

Range Factor	Glycol Concentration Percentages and Performance Impact		
	30%	40%	50%
Lowest Ambient Temperature	10°F (-12 °C)	-4°F (-20°C)	-20°F (-29°C)
Recommended Minimum Leaving Fluid Temperature	25°F (-4 °C)	10°F (-12°C)	-10°F (-23°C)

Table 10. Water quality guidelines (continued)

Element/Compound/Property	Value/Unit
Sulphate (SO ₄ ²⁻)	<100 ppm
Hydrogen Carbonate (HCO ₃ ⁻)	60 – 200 ppm
(HCO ₃ ⁻)/(SO ₄ ²⁻)	>1.5
(Ca + Mg)/(HCO ₃ ⁻)	>0.5
Chloride (Cl ⁻)	<200 ppm

Notes:

1. Total Hardness/corrosion: Water with high hardness can cause corrosion problems due to its high ion content (Ca+2, Mg+2, Fe+2) which also means a high electrical conductivity and a high total dissolved solid (TDS). For this reason, too high hardness values should be avoided, not only due to higher risk of scaling, but also for corrosion risk. On the other hand, soft water, but not necessarily cation exchange softened water, may in contrast have a low buffering capacity and so be more corrosive. If the hardness values are outside the recommended range, other parameters such as oxygen content, conductivity, and pH values should be considered to evaluate the corrosion risk.
2. Fe³⁺ and Mn⁴⁺ are strong oxidants and may increase the risk for localized corrosion on stainless steels in combination with brazing material copper.

Monitor Water Quality

Maintaining water/glycol mixture quality and cleanliness is critical to chiller health and maintainability. Strainers should be checked and cleaned on a regular basis. Water/glycol mixture samples should be taken and tested by a professional lab. The results will enable the accurate adjustment of quality thereby increasing the operational life of the chiller.

Note: Trane will not validate the chiller warranty if the proper water/glycol mixture composition and quality is not maintained.

Maintain Glycol Level

The temperature of the refrigerant in a brazed-plate evaporator is not uniform throughout the heat exchanger.

The refrigerant temperature is approximately 6°F to 12°F colder than the corresponding fluid temperature depending on many factors such as the heat exchanger design, glycol percentage, operating fluid temperatures, refrigerant, system flow rate, etc. When the chiller has a set point that is within 12°F (6.7°C) of the freezing point of the water/glycol in use, take precautions against freezing.

See Table 11, p. 46 below for the recommended glycol concentrations and performance impact.

Table 11. Glycol performance impact factors (continued)

Range Factor	Glycol Concentration Percentages and Performance Impact					
	Capacity Reduction Factor	Pressure Drop Factor	Capacity Reduction Factor	Pressure Drop Factor	Capacity Reduction Factor	Pressure Drop Factor
Leaving Temperature						
70°F (21°C)	0.96	1.27	0.93	1.43	0.91	1.63
60°F (15.6°C)	0.95	1.31	0.92	1.47	0.90	1.68
55°F (13°C)	0.95	1.31	0.92	1.50	0.89	1.73
50°F (10°C)	0.94	1.33	0.91	1.51	0.88	1.75

A 20% to 50% solution of glycol should be added to prevent pipe corrosion regardless of the fluid temperature. Propylene glycol has corrosion inhibitors that protect piping and components from corrosion and buildup of rust and other deposits. Trane recommends against using water/glycol solution in excess of 50% regardless of the ambient temperature conditions.

To assure inhibitor effectiveness, the levels of chlorides and sulfates in the water should not exceed 25 ppm each. The total hardness in terms of calcium carbonate should be less than 100 ppm. For best long-term results, de-ionized or distilled water is recommended. Trane can provide concentrated solutions of Dowfrost, propylene glycol, or premixed solutions for use with the chiller.

NOTICE

Equipment Damage!
 Failure to follow instructions below could result in permanent damage to pump and internal cooling surfaces.
 Do not use automotive antifreeze.

NOTICE

Equipment Damage!
 Failure to follow instructions below could result in permanent damage to pump and internal cooling surfaces.
 Do not use automotive antifreeze.

Note: If glycol-free solutions are mandated at the chiller site, special inhibitors are available for rust prevention, mineral deposit inhibition, and biological suppression. Adding these inhibitors to the water solution is strongly recommended.

Heaters, heat tracing cable, and closed cell insulation can be installed on any exposed “wet” chiller components and tank and pump modules for protection against freezing in low ambient temperature and low refrigerant pressure conditions. However, the best freeze prevention is using the appropriate concentration of glycol. Trane does not warranty any component that fails due to freezing.

Prevent Freezing

Many liquids expand in volume upon cooling. This expansion may cause pipes and other enclosed systems containing a liquid to rupture or burst when exposed to low temperature conditions. Burst protection is needed to protect piping and other enclosed systems when they are inactive as they could rupture due to expansion during cold weather or low refrigerant pressure.

Freeze points and burst points of glycol-water solutions are shown in [Table 12, p. 48](#).

In order to maintain a high quality glycol solution, the water used in the glycol mixture must have very few impurities. Impurities in the water can increase metal corrosion, aggravate pitting of cast iron and steel, reduce the effectiveness of the corrosion inhibitors, and increase the depletion rate of the inhibitor package.

Propylene Glycol

Glycol-based fluids provide such burst protection in water solutions due to their low freezing points. As a glycol-based fluid cools below the solution’s freezing point, ice crystals begin to form, and the remaining solution becomes more concentrated in glycol. This ice/water/glycol mixture results in a flowable slush, and remains fluid, even as the temperature continues to cool.

The fluid volume increases as this slush forms and the temperature cools, flowing into available expansion volume in the chiller. If the concentration of glycol is sufficient, no damage to the chiller from fluid expansion should occur within the temperature range indicated in [Figure 23, p. 48](#). When liquids are cooled they eventually either crystallize like ice or become increasingly viscous until they fail to flow and set up like glass. The first type of behavior represents true freezing. The second is known as super-cooling. Glycols do not have sharp freezing points. Under normal conditions, propylene glycol sets to a glass-like solid, rather than freezing.

The addition of glycol to water yields a solution with a freezing point below that of water. This has led to the extensive use of glycol-water solutions as cooling media at temperatures appreciably below the freezing point of water. Instead of having sharp freezing points, glycol-water solutions become slushy during freezing. As the temperature falls, the slush becomes more and more viscous and finally fails to flow.

Table 12. Freeze and burst protection chart

Water/Glycol Temperature	Freeze Protection	Burst Protection
20°F (-7°C)	18% glycol mixture	12% glycol mixture
10°F (-12°C)	29% glycol mixture	20% glycol mixture
0°F (-17.8°C)	36% glycol mixture	24% glycol mixture
-10°F (-23°C)	42% glycol mixture	28% glycol mixture
-20°F (-29°C)	46% glycol mixture	30% glycol mixture

The precise concentration of glycol for a particular chiller is affected by several key factors such as ambient temperature extremes, entering and leaving water temperatures, and chiller size. A chiller's optimum glycol concentration is modified by these considerations as reflected in [Table 11, p. 46](#). These capacity correction factors are the "best informed estimates" for chiller with copper evaporators. The percentages may vary depending on the materials and alloys of the heat exchangers, total surface area, the amount of present or future fouling, and the brand of glycol used.

Storage Provisions

The chiller controls are designed for storage in ambient temperatures from -20°F (-29°C) to 145°F (63°C) with relative humidity from 0% to 100%. The glycol should be removed from the chiller if the unit is to be stored for extended periods. Although fluids can be drained via the

plug in the bottom of the evaporator, the inhibitors in an approved glycol solution will best protect the surfaces of the evaporator against oxidation if the glycol remains inside the chiller during storage.

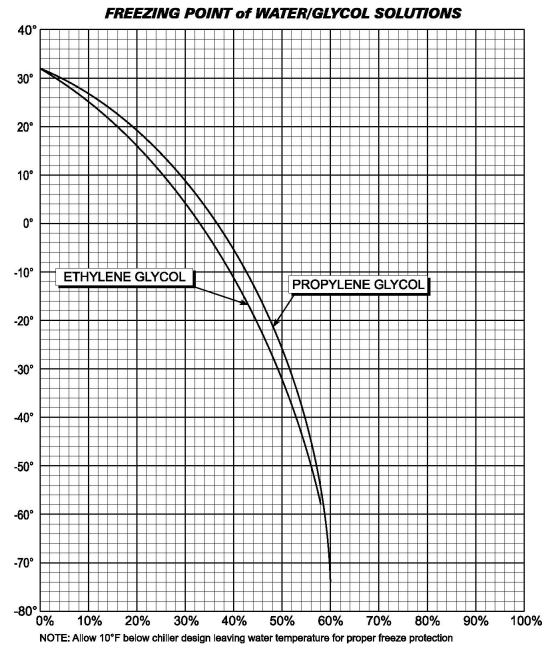
Figure 23. Water/Glycol concentration freezing points (in degrees fahrenheit)



Controls Interface

Microprocessor Control System

AMC chiller models employ a Carel c.pCO all-digital data control system to control and report key system settings and indicators.

Primary Microprocessor Controller

Both the primary and secondary modules use a Carel c.pCO medium microprocessor controller. The primary microprocessor controller rotates the lead compressors every 168 system operating hours. See figure below.

Figure 24. c.pCO primary controller



Secondary Microprocessor Controller

In a normal configuration, a secondary controller controls the single module to which it is dedicated. The distributed primary microprocessor controller system enables the chiller in the event the primary microprocessor controller fails. The system automatically fails over to distributed primary control where each secondary controller operates its own module but lacks the ability to rotate the lead compressors every 168 system operating hours.

Touchscreen Interface Panel

The touchscreen interface panel is the primary means for controlling and monitoring the system for the operator and maintainer. See [Figure 25, p. 49](#).

Figure 25. Touch interface panel



Operator Control and Monitoring

Each system is provided with a touchscreen interface panel that is used to turn the chiller on and off, adjust set points, clear alarms, and perform detailed set-up of the microprocessor controllers.

Chiller Control

The operator uses three different types of controls and indicators to monitor and maintain the desired operating parameters in the AMC chiller - Power Distribution, Electrical Controls, and Refrigeration Controls. These controls and indicators are located in the power panels and the microprocessor controllers.

Power Distribution

There are two different electrical panels used in AMC chiller. The main power distribution panel receives power from the building source and distributes it to the individual chiller modules. The module electrical and control panel receives power from the power distribution panel and provides power to individual electrical components.

⚠ WARNING

Hazardous Voltage!
Failure to disconnect power before servicing could result in death or serious injury.
Disconnect all electric power, including remote disconnects before servicing. Follow proper lockout/tagout procedures to ensure the power can not be inadvertently energized. Verify that no power is present with a voltmeter.

Main Power Distribution

The power distribution panel distributes electricity from the external building power supply. It also houses a circuit breaker for each module, a phase monitor, and an optional main power disconnect switch. See [Figure 26, p. 50](#).

Figure 26. Power distribution panel

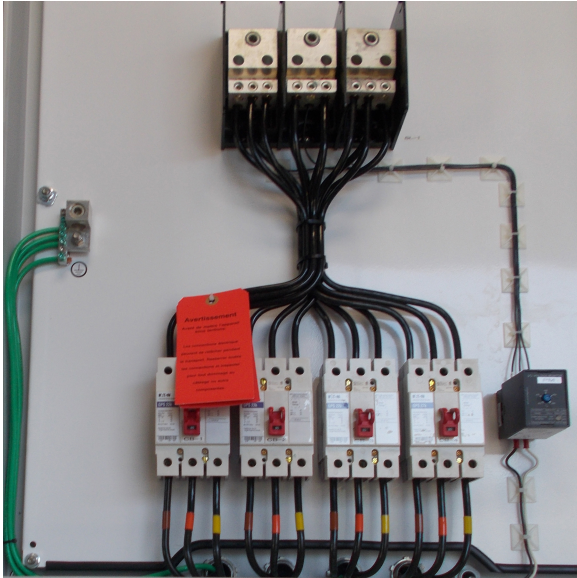

Panel Disconnect

Some AMC chiller systems are optionally equipped with a panel-mounted disconnect switch installed on the outside of the power distribution panel (or on each module's electrical and control panel if the chiller has power supplied directly to each individual module). The disconnect switch must be turned to the OFF position before the panel can be opened for service.

Module Electrical and Control Panel

The Electrical and Control Panel receives power from the power distribution panel and provides power to the individual electrical components in that module. Each module has its own high voltage electrical panel and low voltage control panel that distributes electricity to individual components. It also has fuses and breakers, compressor switches, and microprocessor controller.

Electrical Controls

AMC chiller is provided with controls and indicators to monitor the electrical activity and notify operators if problems arise.

Flow Switch

A flow switch is wired into the low voltage control circuitry used to detect the flow of liquid through the evaporator circuit. Flow switches close when flow is detected allowing compressors to start. If there is no flow, compressors cannot operate.

After every chiller power-on, all LEDs on the flow switch illuminate and go out again in sequence. The switch is ready for operation when an amber LED is visible on the switch display:



NOTICE

Proof of Flow Switch!

Failure to provide flow switches or jumping-out of switches could result in severe equipment damage. Evaporator and condenser water circuits require proof of flow switches.

- Failure to include the proof of flow devices and/or jumping out these devices could cause the unit to stop on a secondary level of protection.
- Frequent cycling on these higher level diagnostic devices could cause excessive thermal and pressure cycling of unit components (O-rings, gaskets, sensors, motors, controls, etc.) and/or freeze damage, resulting in premature failure of the chiller.

Phase Monitor

A phase monitor is used on three-phase power systems to confirm that the electricity supplying the chiller is configured appropriately. A phase monitor prevents a motor from operating in reverse – if any of the three legs of power are landed incorrectly – and will shut the system down upon detection of a reversed phase condition.



Refrigeration Controls

Mechanical controls on the refrigeration system are designed to provide safety for the major components and for proper operation of the system.

Pressure transducers convert pressure into an electronic signal that the microprocessor displays in pounds per square inch (psi) or bar.

Temperature sensors transmit temperature data electronically to the microprocessor for display in either Fahrenheit (°F) or Celsius (°C).

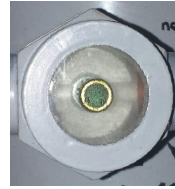

Expansion Valve

An expansion valve is a metering device controlling the flow of refrigerant to the evaporator based on the evaporator superheat.

Superheat is factory-set for around 12°F (6.7°C). Close the valve to increase superheat. To accurately read superheat, install a temperature sensor at the evaporator outlet. The sensor bulb should be located at the 4 o'clock or 8 o'clock positions on the pipe for the most accurate pressure measurement.

Confirm that the closed-cell insulation covers the thermal expansion valve sensing bulb. If insulation is missing, the bulb will tend to feed more refrigerant to satisfy the superheat setting.



Solenoid Valve

The liquid-line solenoid valve is used in the refrigeration cycle to provide a refrigerant pump-down cycle at the end of a compressor cycle. The liquid refrigerant is pumped out of the evaporator to eliminate liquid refrigerant from migrating to the compressor in the off cycle.



Sight Glass

When the sight glass shows a green indicator, no moisture is present. When the sight glass shows a yellow indicator, there is moisture in the refrigerant line. Bubbles can be observed whenever chiller cycling causes the pressure to change up or down.

NOTICE

Equipment Damage!

Failure to remove moisture from system could cause corrosion within the chiller/heater components, and degrade performance.

Perform vacuum evacuation of system to remove moisture.

Low Pressure Bypass

Logic that uses a time delay that temporarily bypasses the low-pressure switch for compressor start up. Once the delay opens (times out) the normal controls are put back on line within the control circuit.

Low Pressure Pump Down (LPPD) Controls

Allows the system to start in low ambient conditions and prevents flood-back to the compressor by pumping the liquid refrigerant out of the evaporator. The LPPD control consists of a pressure switch that is set at "cut in" and "cut out" pressures that depend on the type of refrigerant in the system and is based on pressure at which the refrigerant reaches the freezing point of the evaporator water/glycol mixture.

The set points are typically just below the freezing point. When using water, the pressure settings for R-454B refrigerant are 75 psig for the "cut out" and 90 psig for the "cut in". For any other water/glycol mixture, contact Trane technical support for proper set points.

High and Low Ambient Controls

Condenser coils must be properly oversized for high ambient operation (or high elevation). In order to prevent refrigerant migration to the condensing coil when operating in low ambient temperatures, it is essential to have effective head pressure control. If the condenser head pressure is not properly regulated, the chiller may not receive sufficient refrigerant, leading to low suction pressure, evaporator freezing, and ultimately causing the chiller to shut down. Flooded condenser head pressure control, fan variable frequency drive, and fan cycling are all used to allow varying degrees of low ambient operation.

Thermal Capacity

The thermal capacity of the chiller modules is dependent on the leaving temperature of the chilled water/glycol mixture, maintaining a minimum flow of water through the evaporator and keeping debris out of the air-cooled condenser. In applications where it is desired to operate with a lower flow rate or higher temperature change, consult the technical support for recommendations.



Sequence of Operations

This manual describes a typical air-cooled chiller system with few, if any, optional components or devices attached. To cover the primary difference in construction and operation, two sequences of operation are included; one for a constant flow chiller system and the other for a variable flow chiller system.

Constant Flow Sequence

1. The chiller is designed to operate with high voltage power always supplied. This will power the compressors' crankcase heaters (air cooled modules only) and minimize liquid refrigerant migration to the compressor sumps.
2. With power on the system, the primary module microprocessor controller selects the lead chiller, and rotates this lead once every 168 hours.
3. The chiller system is enabled when the system on/system off icon on the HMI touch screen display is pressed and held for 3 seconds. In addition, the remote start/stop relay must be in the "start" position.
4. For systems with a tank and pump module, the lead chiller pump energizes when the chiller is enabled. If the flow switch within the tank and pump module closes within the time delay period, the lead pump turns on. If the lead pump fails to start or the flow switch not close within the time delay period, the pump de-energizes and the lag pump energizes. An alarm signal generated on the primary microprocessor controller indicates failure of the lead pump.
5. Once the flow is established and the system demand (based on leaving fluid temperature) indicates that there is a requirement for cooling, the lead compressor of the lead module energizes, provided all safeties of that refrigeration circuit are met.
6. As the system demand continues to increase, the leaving fluid temperature from the chiller slowly increases until the differential set point is reached (set point plus 4°F). When the differential is reached, the compressor on the lead circuit of the next module selected to start based on the primary controller sequential operating order energizes, provided all safeties on that circuit are met.
7. Regardless of the demand, compressors will not turn on within 5 minutes of one another to prevent excessive compressor cycling. Each compressor runs for a minimum of 5 minutes regardless of the system leaving fluid temperature.
8. As the system demand continues to increase, the first compressor on the lead refrigeration circuit from the next module in the starting sequence (or if there are only two total modules, the second compressor on the second circuit of the lead module) will be brought on-line.
9. As the demand continue to increase and the temperature once again reaches the set point plus differential setting, a fourth compressor from the fourth sequential module (or the second compressor of the second module if there are only two modules) is brought on-line. This process occurs throughout the operating range of the chiller system when there is increasing cooling demand.
10. On a decrease in system demand such that the leaving fluid temperature reaches the set point minus the differential (set point minus 1°F), compressor(s) de-energizes in the reverse order that they turned on after all timers have been satisfied.
11. Regardless of demand and leaving fluid temperature, there must be no less than 5 minutes between successive compressor(s) de-energizing to prevent excessive compressor cycling.
12. The microprocessor provides a new lead chiller module once a week to even out the compressor run time between the modules.
13. For water cooled chiller systems with condenser fluid temperature that enters below 65°F, a two-way water regulating valve is provided on each condenser. The valve modulates to allow enough fluid to flow through the condensers to maintain refrigeration head pressure.
14. For water-cooled chillers with condenser fluid flow rate that must remain constant, a three-way regulating valve can be provided on each condenser to maintain refrigeration head pressure when the entering condenser fluid temperature is below 65°F. The regulating valve bypasses some fluid away from the condensers to the fluid return pipe yet allows enough to flow through the condensers to maintain refrigeration head pressure.

Variable Flow Sequence

1. The chiller is designed to operate with high voltage power always supplied. With power on the chiller system, the lead module's electronic isolation valves energizes and opens.
2. The chiller system is enabled when the system on/system off icon on the HMI touch screen display is pressed and held for 3 seconds. In addition, the remote start/stop relay must be in the "start" position.
3. The variable frequency drives (VFD) for the chiller pumps monitors the opening and closing of the electronic valves on the evaporators which are controlled based on chiller system leaving fluid temperature. The pump speed varies proportionally to the number of modules that are operating (electronic valves open) in the chiller system. The VFDs can also be controlled based on the system differential pressure - or a flow meter provided by others - but minimum pump(s) speed must not be lower than that required by

the one operating module. The control of the variable primary pumps must be based on the differential pressure measured across the most remote fan coil in the hydronic system and not the pressure differential across the chillers (the evaporator in each module contains a fine mesh strainer which can skew differential pressure readings). The VFDs allow the pumps to deliver the required flow through each operating module.

4. The electronic isolation valve of the lead chiller module identified in step 2 is already energized, therefore, the system pump must produce the minimum flow required by the lead chiller module. A system bypass with modulating valve is provided by the customer and installed external of the chiller at the most remote fan coil or other suitable remote location from the chillers (a high-quality pressure independent valve is recommended for this bypass so as to provide accurate bypass control regardless of system pressure differential between supply and return headers).
5. Once there is a system load, the BMS modulates the system bypass valve, decreasing the bypassed flow, as the flow rate through the fan coils increase. This control is provided by the customer external of the chiller and is presumed to be based on the pressure differential across the most remote fan coil or user.
6. Once the minimum flow is established and the system demand (based on leaving fluid temperature) indicates that there is a requirement for cooling, the lead compressor of the lead module energizes provided all safeties of that refrigeration circuit are met.
7. As the system demand continues to increase, the leaving fluid temperature from the chiller slowly increases until the differential set point is reached (set point plus 4°F). The second compressor in the lead

module energizes, provided all safeties on that circuit are met.

Note: *Regardless of demand, compressors will not turn on within 5 minutes of one another to prevent excessive compressor cycling. Each compressor runs for a minimum of 5 minutes regardless of the system leaving fluid temperature.*

8. As the cooling demand continues to increase, the leaving fluid temperature from the chiller system slowly increases. The first compressor on the lead refrigeration circuit from the second module in the starting sequence will be brought on-line.
9. When the leaving fluid temperature once again reaches the set point plus differential setting, the second compressor on the second module energizes.
10. With increased demand, the third module's lead compressor and then its second compressor - as necessary - will turn on but not less than 5 minutes apart. This process occurs throughout the operating range of the chiller system.
11. On a decrease in system cooling demand such that the leaving fluid temperature reaches the set point minus a differential (1°F below set point), compressor(s) de-energizes in the reverse order that they turned on after all timers have been satisfied. The electronic valve on non-operating modules closes.
12. Regardless of demand and leaving fluid temperature, there must be no less than 5 minutes between successive compressor(s) de-energizing to prevent excessive compressor cycling.
13. The microprocessor provides a new lead chiller module once a week to even the run time between the modules.



Start-Up

Preparation for Initial Start-Up

After the system is completely installed with all wires connected and all piping securely coupled, the chiller can be prepared for initial start-up.

Confirm there is a sufficient cooling load available for proper testing of the chiller system.

⚠ WARNING

Hazardous Voltage!

Failure to disconnect power before servicing could result in death or serious injury.

Disconnect all electric power, including remote disconnects before servicing. Follow proper lockout/tagout procedures to ensure the power can not be inadvertently energized. Verify that no power is present with a voltmeter.

Initial Start-Up Checklist

1. Close all drain valves and header purge valves.
2. Fill the chiller with clean fluid mixture.
3. Inspect all connections for leaks during the filling process.
4. De-energize chiller using industry-standard lockout/tagout procedures. Verify main power is turned off at the power distribution panel. Validate de-energization using voltage meter.
5. Inspect all electrical connections to confirm terminals are secure.
6. Inspect all fuses and overload settings to confirm they meet specifications.
7. Inspect all refrigerant pressures for each module to confirm no refrigerant is lost.
8. Confirm the oil level is correct in each compressor.
Note: If Trane pumps are provided, check that each pump's overload setting matches the nameplate amperage of the pumps as described previously. "Bump" pump motors on to verify correct rotation.

NOTICE

Compressor Failure!

Failure to follow instructions below could result in catastrophic compressor failure.

Do not operate with insufficient oil.

9. Connect phase monitor wiring, if required.
10. Confirm refrigerant valves are open at the compressors.
11. Confirm that pressure and temperature switches are in the closed position.
12. Apply power to all modules in the chiller system. (If a tank and pump module is included, there are switches inside the module control cabinet to start the pumps. Confirm that the pump rotation is correct.)
13. Turn on the evaporator fluid pumps and confirm there is proper flow and the pressure drop across the system is as expected.

Table 13. Initial start-up readiness checklist

<input type="checkbox"/>	Start-Up Readiness Dimension
<input type="checkbox"/>	Describe voltage service: <input type="checkbox"/> Fused disconnect <input type="checkbox"/> Non-fused disconnect <input type="checkbox"/> 50 Hz <input type="checkbox"/> 60 Hz
<input type="checkbox"/>	Record rated power supply: _____ volts _____ phase • Circuit breaker rating: _____
<input type="checkbox"/>	Record supply voltage on chiller nameplate: _____
<input type="checkbox"/>	Record power supply voltage to ground: L-1 = _____, L-2 = _____, L-3 = _____
<input type="checkbox"/>	Record voltage between each phase: L-1 to L-2 = _____, L-2 to L-3 = _____, L-1 to L-3 = _____ <input type="checkbox"/> Agrees with nameplate values? <input type="checkbox"/> Voltages must be within 2%.
<input type="checkbox"/>	Check the box if all electrical connections inside the power distribution panel are tight.
<input type="checkbox"/>	Check the box if all electrical connections inside each module electrical and control panel are tight. Confirm all components inside each module are securely mounted and have not shifted during shipment.
<input type="checkbox"/>	Record the control voltage between TB-1-1 and TB-2-1: _____
<input type="checkbox"/>	Check the box if chiller system includes any remote panels (city water switchover, remote control panel, or customer supplied control devices). If so, voltage drops are likely to occur. Measure and record all control voltages: List devices: Voltage 1 = _____ Voltage 2 = _____ Voltage 3 = _____
<input type="checkbox"/>	Check the box if there are any field-supplied wiring junction boxes located between the chiller and any remote panels.
<input type="checkbox"/>	Check the box if there are any splices made in the field-supplied wiring junction boxes.
<input type="checkbox"/>	Check the box if there are any customer-supplied devices connected to the chiller wiring. List devices: _____
<input type="checkbox"/>	Check the box if there are any Trane remote devices connected to the chiller wiring.
<input type="checkbox"/>	Check the box if voltage drops are detected.
<input type="checkbox"/>	Check the box if the appropriate water/glycol mixture has been added to the chiller.
<input type="checkbox"/>	Check the box if all chiller modules are installed with minimum clearances available from all sides.
<input type="checkbox"/>	Check the box if refrigeration gauges are indicating equal refrigerant pressures.
<input type="checkbox"/>	Check the box if chilled water lines from chiller to customer's equipment are permanently connected.
<input type="checkbox"/>	Check the box if chilled water lines have been flushed clean of mud, slag, and other construction debris.
<input type="checkbox"/>	Check the box if all chilled water line filters and strainers are clean.
<input type="checkbox"/>	Check the box if chilled water lines have been leak tested according to pre-start-up instructions.
<input type="checkbox"/>	Check the box if chiller reservoir (if included) is at operating level with correct water/glycol mixture.



Start-Up

Table 13. Initial start-up readiness checklist (continued)

<input type="checkbox"/>	Start-Up Readiness Dimension
<input type="checkbox"/>	Check the box if high voltage wiring is installed, tested, and functional.
<input type="checkbox"/>	Check the box if all water, refrigeration, and electrical connections between chiller modules are completed.
<input type="checkbox"/>	Check the box if all control wiring between modular chillers is installed, tested, and functional.
<input type="checkbox"/>	Check the box if control wiring is complete, including any additional remote interface panel or special-purpose wiring.
<input type="checkbox"/>	Check the box if all responsible installing contractors and sub-contractors have been notified to have representatives available on site to provide technical support for the initial start-up procedure.
<input type="checkbox"/>	Check the box if full load will be available for chiller on the initial start-up date.
<input type="checkbox"/>	Touchscreen Interface Panel: Record version and date of the software loaded into the touchscreen interface panel: Version: _____ Date: _____ Note: <i>To view the software version, from the home screen, press the software button on the System Control screen.</i>

Start-Up

As part of a continuous commitment to quality, initial start-up of this chiller must be done by Trane.



Maintenance Procedures

Maintenance Strategy

The primary goal of preventive maintenance is to avoid the consequences of failure of equipment. Trane chiller components are designed to be easily accessed for servicing.

One approach to chiller maintenance envisions three levels of maintenance effort reflecting frequent, periodic, and scheduled maintenance tasks, with each level building on the previous level.

- A daily or weekly “health check” involves habitual visual and manual inspections of the components of the

chiller so that anomalies become evident when they occur.

- Weekly or monthly periodic maintenance involves cleaning specific components and inspecting glycol and lubrication fluids.
- Prudent maintenance strategy will anticipate and schedule replacing or rebuilding of critical components before they fail and require emergency response to keep chiller operational. See the following figure.

Maintenance for HVAC equipment and facilities can include a “preventive maintenance checklist” which includes small checks which can significantly extend service life.

Figure 27. An approach to chiller maintenance

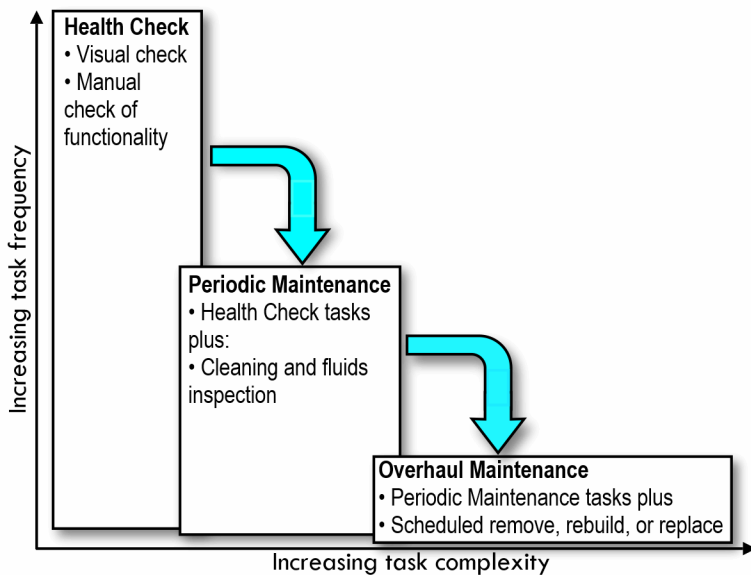

Power Disconnect Switch

Some AMC chiller units are optionally equipped with a panel-mounted disconnect switch installed on the outside of the power distribution panel (or on each module’s electrical and control panel if the chiller has power supplied to each individual module). The disconnect switch must be turned to the off position before the panel can be opened for service. When the panel door is open, power can be reconnected by turning the handle located on the inside of the panel to the ON position.

⚠ WARNING

PPE for Arc/Flash Required!

Failure to wear appropriate PPE could result in death or serious injury.

On this unit, if the handle shield is cracked the circuit breaker could arc/flash when reset. To avoid being injured, technicians **MUST** put on all necessary Personal Protective Equipment (PPE), in accordance with NFPA70E for arc/flash protection, **PRIOR** to entering the starter panel cabinet.



Maintenance Procedures

NOTICE

Component Damage!

Failure to follow instructions could damage sensitive electronic components beyond repair.

To prevent arcing or surges of electrical current, do not use wires or cables to jump components or bypass the manufacturer's safety systems.

Federal Clean Air Act

Responsible refrigerant practices are important to the environment, our customers, and the air conditioning industry. All technicians who handle refrigerants must be properly certified. The Federal Clean Air Act prescribes procedures for handling, reclaiming, recovering, and recycling of refrigerants and the equipment that must be used in maintenance procedures involving potential leakage of HVAC refrigerants. State and local governments

may have additional requirements that must be followed to responsibly handle HVAC refrigerants.

Inspection and Maintenance Schedule

Proactive measures should be taken to prevent potential problems with the chillers. These include maintaining a operational log and conducting weekly, quarterly, and annual inspections of the chiller. See the following table.

Daily

A daily visual inspection can reveal obvious problems. Keep notes of the chiller performance:

- Log pressures and temperatures.
- Visual inspect of the unit.

Table 14. Recommended chiller service intervals

Task	Frequency
Visually inspect the chiller	Daily
Log pressure and temperatures	Daily
Inspect touchscreen interface panel for alarm history	Weekly
Clean strainers on the inlet water pipe	Monthly
Check the compressor oil level sight glass	Monthly
Confirm the glycol concentration	Monthly
Confirm the refrigeration pressures	Monthly
Check the refrigeration liquid line sight glass	Monthly
Inspect refrigerant pressures and temperature set points	Quarterly
Inspect superheat (10°F to 12°F [5°C to 6°C]) and sub-cooling temperatures (10°F to 15°F [5°C to 8°C])	Quarterly
Inspect the evaporator entering and leaving evaporator temperature	Quarterly
Collect water/glycol mixture sample for analysis	Quarterly
Inspect crankcase heaters	Quarterly
Inspect piping for signs of leaks	Quarterly
Inspect refrigerant piping for oil or refrigerant leaks	Quarterly
Observe refrigeration operating pressures	Quarterly
Confirm motor amperage draw and voltage	Quarterly
Confirm chiller superheat and sub-cooling	Quarterly
Check for worn or burned contactors	Quarterly
Inspect all electrical connections and fuses	Annually
Inspect each compressor for refrigerant pressures, overheating, oil leaks	Annually
Inspect compressor terminals for pitting, corrosion, and loose connections	Annually
Inspect compressor oil level	Annually
Confirm and record compressor amperage draw and voltage	Annually

Table 14. Recommended chiller service intervals (continued)

Task	Frequency
Compare fluid flow against design specifications	Annually
Tighten rotalock fittings, if equipped	Annually
Inspect fan blades for signs of failure such as hairline fractures in the blade	Annually

Weekly

Weekly inspection is a continuation and elaboration of daily best practice:

- Inspect touchscreen interface panel for alarm status and additions to the alarm history. (Do not clear alarms as this is a very important performance record if troubleshooting problems occur.)
- Notate and record any excessive vibrations or motor noise.
- Measure all refrigerant static pressure on any idle circuits. Record any significant changes or reductions in pressure.
- Initially, clean strainers weekly after start-up. Thereafter, inspect and clean strainers as needed.

Monthly

NOTICE

Compressor Failure!

Failure to follow instructions below could result in catastrophic compressor failure.

Do not operate with insufficient oil.

The monthly maintenance inspection examines many items that generally require frequent attention. This routine event identifies small problems early before they can become big problems requiring serious repair and refurbishment:

1. Verify that the strainer(s) are clean.
2. Check the compressor oil level sight glass. The oil should always be clear and free-flowing. Any milky appearance indicates that liquid refrigerant is making its way back into the compressor and will cause premature compressor failure.

NOTICE

Equipment Damage!

Failure to remove moisture from system could cause corrosion within the chiller/heater components, and degrade performance.

Perform vacuum evacuation of system to remove moisture.

3. When the compressor is not operating, the oil level should be at least at the bottom of the sight glass, up to two-thirds full. When the compressor is operating, the oil level will normally be at the bottom of the sight glass, or even below, but it must be visible.

4. Low oil sight glass conditions could signify a short cycling, an oil leak, or an undercharged chiller that lacks proper refrigerant velocity to return oil to the compressor sump. Eventually, dry compressor starts could occur causing premature compressor failure. This may indicate that some oil has been lost from a previous refrigerant leak repair. The compressor data label indicates the correct oil type and quantity with which it should be filled.

Note: A flashlight may be required to see the oil churning in the sump of the compressor. Adjusting the line of sight may be necessary to visually inspect the oil in the compressor sump during operation. At a minimum, the oil must be seen churning in the compressor sump. It should be clear.

5. Check the glycol concentration using a refractometer.
6. Check the refrigeration pressures. For R-454B refrigerant, low pressure refrigeration gauge should read 100 psi to 160 psi and high pressure refrigeration gauge should read 270 psi to 570 psi.

NOTICE

Compressor Damage!

Failure to follow instructions below could result in extensive compressor damage.

Verify that suction pressure is sufficient. Secure the circuit or module offline until status can be examined in detail.

Important: Extended operation with suction pressures below 80 psi is a clear sign of insufficient refrigerant charge, refrigeration obstruction, or valve closed. This can cause extensive damage to a compressor.

7. Check the refrigeration liquid line sight glass for persistent bubbles (“flashing”).

Note: Bubbles in the sight glass do not necessarily indicate loss or lack of refrigerant charge. Bubbles (commonly known as “flashing”) will occur whenever the condenser fans cycle until the expansion valve settles out the refrigerant flow. Occasional bubbles also form when the condenser head pressure control valve bypasses hot gas around the condenser coil in low ambient operation. If the refrigeration pressures are in the normal range, the unit is most likely adequately charged.



Maintenance Procedures

Quarterly

The quarterly maintenance inspection is a comprehensive event that examines all aspects of the chiller to identify early problems before they can damage a chiller and require major repair or refurbishment:

1. Inspect alarm log, refrigerant operating/static pressures and temperature set points of each module independently.
2. Inspect chiller superheat and sub-cooling. System superheat should be 10°F to 12°F (5°C to 6°C). System sub-cooling should be 10+°F (5°C) depending on the ambient conditions.
3. Inspect the approach delta T - entering evaporator fluid mixture temperature and leaving refrigerant temperature.
4. Inspect strainers. Confirm bypass valve is properly adjusted to a minimum of 25% open position.
5. Collect chilled water/glycol mixture sample for professional analysis. Check for cleanliness. Drain and refill with clean solution if excessive sludge or dirt is present. Flush the chiller prior to refilling.
6. Inspect fluid mixture levels. Add glycol as required.
7. If equipped, inspect crankcase heaters for proper operation.
8. Inspect the water piping for signs of leaks at joints and fittings.
9. Inspect refrigerant piping circuit for signs of oil or refrigerant leakage. Conduct "sniffer test" to find refrigerant leaks. Inspect all pressure switch bellows.
10. Tighten all refrigeration piping connections (e.g. rotalocks, Schrader valves, caps, and ball valves).
11. Install a manifold and gauge set to observe chiller's refrigeration operating pressures.
 - a. Verify that the pressure controls (low pressure and high pressure switches) are "cutting in" and "cutting out" at the appropriate pressures.
 - b. Verify refrigerant charge by recording the superheat and sub-cooling temperatures.
 - c. Observe head pressure for signs of improper condensing from clogged strainers, or a modulating expansion valve issue.
12. Check compressor motor amperage draws and voltage supplies and maintain a record of those values. Verify that they are within the name plate rating. Also, check for voltage imbalance. The chiller's phase monitor will open if the voltage imbalance exceeds 4%.
13. Check for chattering, excessive wear or burned contacts. Replace contacts, if in doubt.

Annually

The annual chiller maintenance inspection is critical to the long-term performance of the chiller. Whether a chiller has a service life of 15 years or 30 years is almost entirely

dependent upon how consistently and how diligently the annual maintenance inspection and tasks are performed. The annual event is a comprehensive inspection that examines all aspect of the chiller to identify and repair small problems before they can become major issues that damage a chiller and require significant repair or refurbishment.

1. Inspect all electrical connections for damage and confirm terminals are tight. Inspect all contactors for pitting and corrosion and replace as necessary.

⚠ WARNING

Hazardous Voltage!

Failure to disconnect power before servicing could result in death or serious injury.

Disconnect all electric power, including remote disconnects before servicing. Follow proper lockout/tagout procedures to ensure the power can not be inadvertently energized. Verify that no power is present with a voltmeter.

2. Inspect fuses to confirm they are secure, of correct amperage rating, undamaged, and functioning.
3. Energize each compressor and check refrigerant pressures, signs of overheating, and oil leaks. Check for noises and for leaks with an electronic or bubble leak detector. Inspect flared fittings, refrigeration gauges, compressor connections, braze joints, pressure switches, and access ports on Schrader valves.

⚠ WARNING

Refrigerant under High Pressure!

Failure to follow instructions below could result in an explosion which could result in death or serious injury or equipment damage.

System contains refrigerant under high pressure. Recover refrigerant to relieve pressure before opening the system. See unit nameplate for refrigerant type. Do not use non-approved refrigerants, refrigerant substitutes, or refrigerant additives.

4. Follow proper "LOTO" procedures to de-energize each module and inspect terminals for pitting, corrosion, and loose connections.
5. Inspect that the oil level is visible in each compressor and not discolored. Annual oil samples should be taken to be analyzed for destructive acids, corrosive materials, or metal deposits.
6. Inspect and record the compressor amperage draws and voltage.
7. Record fluid mixture flow to confirm it meets design specifications.
8. If equipped, tighten rotalock fittings. The recommended torque is 80 ft-lbs for 2 inch and larger and 60 ft-lbs for rotalock fittings smaller than 2 inches.

9. Inspect all copper lines and control capillary tubing to confirm that the lines are separated and not vibrating against one another or the frame or housing.
10. Confirm all refrigeration lines are properly supported to prevent vibration from causing premature failure of copper piping.
11. Inspect all insulation on piping and control sensors. Repair and replace as necessary.
12. Inspect entire plumbing system for leaks.
13. If equipped, inspect crankcase heaters to verify proper operation.
14. Sample refrigerant to analyze for moisture or acid.
15. Inspect operating pressures and temperatures and confirm the chiller has a full refrigerant charge.

Pump and Tank Maintenance Tasks

For chillers equipped with a tank and pump module, additional maintenance steps are required at least every six months:

1. Confirm that the pump, motor, and the immediate area are clear of dirt, debris, leaves, animal nests, and so forth.
2. Confirm pump mountings are secure and fasteners are tight to prevent pipe movement and eventual failure.
3. Inspect pump for proper rotation.
4. Check pump for leaks and excessive noise while in operation.
5. Lubricate pumps as recommended by the manufacturer. Refer to the pump manufacturer's operating and maintenance manual for lubricating instructions, if any are required.
6. Test and record the motor amp draw under full load.
7. Test the pump overload protection device. Adjust if necessary.

Maintenance Tasks

The maintenance tasks described herein present the basic, minimal, steps required to successfully complete a task. Local policies and protocols may require more elaborate procedures with additional checks and inspections.

Inspection Methods

Appropriate inspection for modern chillers can be described as hands on. Where possible and appropriate, inspection should include touching the component or apparatus. The sense of touch provides additional feedback regarding temperature, texture, tightness, and dryness that cannot match the visual inspection. Habitually touching each item to be inspected also ensures that items are not subconsciously skipped during the inspection process. For a summary of tasks, see [Table 14, p. 58](#).

⚠ WARNING

Hazardous Voltage!

Failure to disconnect power before servicing could result in death or serious injury.

Disconnect all electric power, including remote disconnects before servicing. Follow proper lockout/tagout procedures to ensure the power can not be inadvertently energized. Verify that no power is present with a voltmeter.

Critical Cleaning Tasks

Monitor temperature change and pressure drops across the BPHE circuit to determine the frequency for strainer cleaning. Monitor water quality in the chiller's closed system to determine the optimum frequency for BPHE cleaning.

On multiple module chillers, Trane provides service isolation valves on each BPHE to isolate each strainer for cleaning without disrupting the operation of any remaining modules in the chiller.

Strainer Cleaning Procedure

Strainers at each BPHE are critical for protecting the small water passages as well as maintaining fluid mixture cleanliness. Service valves on the BPHE isolate each strainer for cleaning without interrupting the operation of other modules in the chiller bank. If a tank and pump module is provided, pot strainers are occasionally included on the pumps' suction lines.

NOTICE

Equipment Damage!

Failure to follow instructions could result in equipment damage.

Do not operate without strainers in place.

1. De-energize power to the module containing the strainer by turning the power OFF at the breaker and/or disconnect (follow proper LOTO procedure).
2. Close the two service isolation valves between the header and the BPHE.

Note: *If this is a variable flow chiller, the outlet may be equipped with an electronic valve that must be manually locked in the closed position.*

3. Remove the insulation to expose the roll grooved blind end cap or service cap on the end of the strainer housing. Utilize a short section of hose to connect to the valve on the end cap to relieve pressure and capture fluid. (Dispose of or re-utilize water/glycol mixture according to local protocols.)

⚠ CAUTION

Explosion Hazard!

Failure to relieve pressure gradually could result in minor to moderate injury and equipment damage. Water/glycol mixture can be under considerable hydraulic pressure in the strainer housing. Close isolation valves fully. Relieve pressure using a boiler vale. Use extreme care to slowly remove the end cap and release pressure gradually.

4. Inspect the gasket and service cap for abrasions, tears, excessive dirt, or deterioration. Replace gasket if necessary.
5. Remove the strainer from the housing.
6. Clean the strainer inside and out using a soft natural bristle brush and tap water.
7. Clean the interior of the end cap (or service cap), and the gasket using a soft natural bristle brush and tap water. Apply a light coating of lubrication to the gasket.
8. Re-install the strainer in the housing (large end first). Replace the gasket and end cap and tighten coupling collar securely.
9. Confirm the fluid make-up system is operational to replenish the fluid mixture lost during the cleaning process.
10. Energize power to the module containing the strainer by turning power ON at the breaker and/or disconnect.

Condenser Cleaning Procedure

Fouling of condenser will result in a gradual decline in performance of the chiller and is particularly significant during high ambient operation:

1. Turn off and LOTO the power to the chiller module or remote condenser.

⚠ WARNING

Hazardous Voltage!

Failure to disconnect power before servicing could result in death or serious injury. Disconnect all electric power, including remote disconnects before servicing. Follow proper lockout/tagout procedures to ensure the power can not be inadvertently energized. Verify that no power is present with a voltmeter.

2. Remove fan assembly to improve access to condenser coils.
3. Use a hose with spray nozzle or a long spray wand with a 90° turn spray head. (DO NOT use a pressure washer on condenser coils).

Note: If chiller is equipped with EC-type fan motors, remove the compressor-side V-baffle end cap.

NOTICE

Coil Damage!

High pressure water from a power washer can damage and distort the cooling fins on the coil. Using a pressure washer on condenser coils is not recommended. Damaged fins can adversely affect chiller efficiency.

4. Clean coils by spraying water in the opposite direction of the air flow, from top of the coil to the bottom. Spray in a consistent pattern to work the dirt and debris from the top to the lower part of the coil.
5. For extremely dirty coils, chemical soaking may be required to loosen debris build-up. Apply chemicals with a hand-held pump sprayer following a similar pattern used in the water cleaning.
6. Let the chemical mixture soak in the condenser for a short period of time to loosen sediment and scale build-up. Trane recommends using water except in extreme cases. (Take extra precautions by covering electrical components with plastic bags, etc.)
7. After chemical cleaning, all surfaces must be flushed thoroughly with clean water to remove residual chemicals. Trace chemical residue may result in premature aluminum fin breakdown and deterioration requiring coil replacement.
8. Securely reinstall fan grill assembly (or V-baffle end cap).
9. Turn power back on individual unit after ensuring all electrical connections are wiped dry.
10. Confirm that each unit's panels are clean and clear of debris.

Note: Do not use chemicals on corrosion prevention coatings.

Evaporator Cleaning Procedure



Trane recommends using SWEP Goodway® Technologies ScaleBreak-MP, an industrial biodegradable descaler which will quickly and effectively dissolve calcium, lime, rust and other water formed deposits from water cooled/heated equipment.

- When applying ScaleBreak-MP in your equipment, it should be circulated through the water passages.
- As the product comes in contact with the deposits, they are dissolved into a liquid suspension.
- Upon completion of the cleaning, the used solution is freely flushed from the system along with the dissolved deposits leaving no residual solution.
- Optimal results are achieved when you pump into the bottom of the equipment and out the top. This method confirms the area to be cleaned was flooded, allowing ScaleBreak-MP to come in contact with all the deposits.

Pump Tasks

The following section applies to those chillers equipped with a tank and pump module.

Remove Pump

1. Confirm module power is OFF by testing with known operational voltmeter. Once confirmed, install lockout/tagout equipment to confirm power is not turned on while service work is being performed.

⚠ WARNING

Hazardous Voltage!

Failure to disconnect power before servicing could result in death or serious injury.

Disconnect all electric power, including remote disconnects before servicing. Follow proper lockout/tagout procedures to ensure the power can not be inadvertently energized. Verify that no power is present with a voltmeter.

2. Remove electrical access cover on the pump motor.
3. Remove all electrical wiring and flex conduit from the pump. Make sure to notate all connection points for the new installation.

Note: Be sure to document conductor/wire numbers

4. Close valves. There are isolation valves on the suction and discharge sides of the pump as well as union connections.
5. Using appropriate wrenches, slowly break loose the union fittings at the suction and discharge piping. Capture any escaping fluids encountered during the pump change out process.

Notes:

- *Always use a second, counter, wrench, when performing plumbing tasks to firmly hold the fittings or joint while loosening or tightening.*
- *A small quantity of fluid mixture will be lost during this operation. Although propylene glycol does not pose an environmental hazard, it is the installers responsibility to adhere to local codes and ordinances involving hazardous fluids.*

6. Loosen the four bolts that attach the pump base to the frame with the appropriate size wrench or socket.
7. Remove the pump.
8. Disconnect the piping stubs from the suction and discharge connections on the old pump to be reused on the new pump.

Install Pump

Verify that power is disconnected from the chiller.

⚠ WARNING

Hazardous Voltage!

Failure to disconnect power before servicing could result in death or serious injury.

Disconnect all electric power, including remote disconnects before servicing. Follow proper lockout/tagout procedures to ensure the power can not be inadvertently energized. Verify that no power is present with a voltmeter.

1. When installing the stubs from the old pump, apply a minimal amount of thread sealant to the threads of the suction and discharge pipe adapters and install the adapters onto the new pump.
2. Position the pump over the mounting holes. Apply anti-seize compound to the four mounting bolts, washers, and fittings before installation. Tighten fittings securely with 1/2 inch socket and wrench.

Note: Do not over-tighten compressor mounting bolts as the threaded inserts could strip out in the frame.

3. Loosely install the four mounting bolts onto the mounting nuts on the chiller frame.
4. Align the pump suction and discharge unions onto the piping connections and hand tighten.

Note: The pump suction pipe stub must be positioned 90 degrees to the right of the pump to mate up to the union on the pump suction piping.

5. Fasten the mounting bolts to the frame using a 1/2 inch wrench or socket. Be sure to reuse the rubber isolation pads from the old pump.
6. Tighten the suction and discharge unions using large adjustable wrenches or pipe wrenches. To minimize the torque on the piping, apply an equal and opposite force to the pipe fitting with an additional adjustable wrench or pipe wrench.

Note: Always use a second, counter, wrench, when performing plumbing tasks to firmly hold the fittings or joint while loosening or tightening.

7. Position the conduit into the knockout of the electrical box cover.
8. Fasten the conduit to the box with the ring nut.
9. Reconnect pump electrical connections exactly as they were notated at removal.



Maintenance Procedures

10. Replace the cover onto the electrical box on the side of the pump motor. Confirm gasket is in place prior to replacing cover.
11. Reconnect the fitting on the strain relief connector from the motor housing using an adjustable wrench.
12. Open the ball valves on the suction and discharge sides of the pump.
13. Restore power to the module by removing the lockout/tagout equipment and turning the pump module breaker back to the ON position.
14. Observe the newly installed pump to verify that all connections have been seated and tightened correctly and not leaking.
15. Turn pump on and record amp draws for your records.

Replace Pump Seal

Prior to servicing the pump, verify that the power to the chiller is disconnected.

1. Confirm module power is OFF by testing with known operational voltmeter. Once confirmed, install lockout/tagout equipment to confirm power is not turned on while service work is being performed.

⚠ WARNING

Hazardous Voltage!

Failure to disconnect power before servicing could result in death or serious injury.

Disconnect all electric power, including remote disconnects before servicing. Follow proper lockout/tagout procedures to ensure the power can not be inadvertently energized. Verify that no power is present with a voltmeter.

2. Remove electrical access cover on the pump motor.
3. Remove all electrical wiring and flex conduit from the pump. Make sure to notate all connection points for the re-installation.

Note: Be sure to document conductor/wire numbers

4. Close valves. There are isolation valves on the suction and discharge sides of the pump as well as union connections.
5. Using appropriate wrenches, slowly break loose the union fittings at the suction and discharge piping. Capture any escaping fluids encountered during the pump change out process.

Notes:

- Always use a second, counter, wrench, when performing plumbing tasks to firmly hold the fittings or joint while loosening the tightening the opposite side.
 - A small quantity of water/glycol mixture will be lost during this operation. Although propylene glycol does not pose an environmental hazard, it is the installers responsibility to adhere to local codes and ordinances involving hazardous fluids.
6. Loosen the four bolts that attach the pump base to the frame with the appropriate size wrench or socket. Keep up with rubber isolation boots for reuse on install.
 7. Remove the pump from the chiller.
 8. Remove insulation from the wet end of the pump to allow volute cover access and removal.
 9. Remove pump volute cover.
 10. Remove retaining nut on shaft which secures seal.
 11. Remove seal.
 12. Remove back plate which will allow you to repair /replace water slinger.
 13. Install new water slinger rubber. Replace back cover.

NOTICE

Pump Seal Damage!

Do not touch seal with bare skin, or allow any grease to come into contact with the new seal. Even a small piece of grit or dirt can damage the pump seal. Wash hands thoroughly prior to installing the new seal. Latex gloves are suggested for handling of parts after they have been cleaned and prepped.

Note: It is highly recommended that you gather seal replacement procedural information for your particular pump make and model.

14. Place the seal, sleeve, spring, and seal retainer onto the shaft.
15. Position the pump impeller and secure into place with the impeller retainer bolt.
16. Replace the volute cover with new o-ring and re-insulate.
17. Re-install pump. Attach the mounting bolts to the frame using a 1/2 inch wrench or socket.
18. Push the conduit and wires into the knockout on the electrical box cover.
19. Attach the conduit to the box with the ring nut. Use a standard screwdriver to secure the nut.
20. Secure the leads with crimp-type bell caps.
21. Reconnect pump electrical connections exactly as they were notated at removal.

22. Replace the cover onto the electrical box on the side of the pump motor. Confirm gasket is in place prior to replacing cover.
23. Reconnect suction and discharge at unions with appropriate size wrenches as with the removal process.
24. Open the ball valves on the suction and discharge sides of the pump.
25. Observe the newly installed pump to verify that all connections have been seated and tightened correctly and not leaking.
26. Restore power to the module by removing the lockout/tagout equipment and turning the pump module breaker back to the on position.
27. Turn pump on and record amp draws for your records.

Controller Tasks

Replace PLC Logic Controller

Prior to servicing the controller, verify that the power to the chiller is disconnected.

1. Remove all quick-connect black plugs and the one orange plug (power supply 24 Vac).

⚠ WARNING

Hazardous Voltage!

Failure to disconnect power before servicing could result in death or serious injury.

Disconnect all electric power, including remote disconnects before servicing. Follow proper lockout/tagout procedures to ensure the power can not be inadvertently energized. Verify that no power is present with a voltmeter.

2. The PLC logic controller is DIN rail-mounted. Once plugs are removed, this will expose the gray secure tabs on the bottom rear of the PLC.
 3. Using a flathead screwdriver, insert screwdriver into the slotted holes on the gray tabs and use downward force to release PLC.
 4. Remove the PLC by lifting the bottom out and then up, off of the DIN rail.
 5. Replace new controller in reverse fashion.
- Note:** *On a multiple modular system with multiple PLC's, it is imperative that the new PLC has the exact same programming as the remaining PLC's or it will not be compatible and would create havoc within the other PLCs.*
6. Energize power to the module by turning power ON at the breaker and/or disconnect.



Chiller Troubleshooting

General Approach to Fault Isolation

Trane manufactures chillers with embedded fault detection and diagnostics in each module's controller that offers continuous dedicated monitoring to record and report faults as they occur in real time allowing repairs to be performed in a timely manner.

Various faults occurring in a building's HVAC system can lead to unnecessary energy consumption and poor thermal comfort for a building's occupants. Fault detection and isolation plays a significant role in monitoring, maintaining,

and repairing chillers to improve operator safety and minimize operating costs.

Fault detection is recognizing that a problem has occurred, even if the root cause is not yet known. Fault isolation is the process of reducing potential causes to determine the most likely source of chiller failure.

Controller Diagnostic Codes

The following table assists in explaining the alarm codes that appear in the remote interface panel in the event of an alarm. The alarm history is accessed by pressing the alarm log key.

Table 15. Interface panel diagnostic code key

Alarm	Type	Action
UI1 sensor failure	Auto Reset	Shuts down Circuit 1 ^(a)
UI2 sensor failure	Auto Reset	Shuts down Circuit 1
UI3 sensor failure	Auto Reset	Shuts down local cooling control ^(b)
UI4 sensor failure	Auto Reset	Locks out module
UI5 sensor failure	Auto Reset	Shuts down local heating control ^(b)
	Auto Reset	Warning
UI6 sensor failure	Auto Reset	Shuts down local heating control ^(b)
	Auto Reset	Shuts down Free Cooling control ^(c)
UI7 sensor failure	Auto Reset	Warning
UI8 sensor failure	Auto Reset	Warning
UI9 sensor failure	Auto Reset	Shuts down Circuit 2 ^(a)
UI10 sensor failure	Auto Reset	Shuts down Circuit 2
UI11 sensor failure	Auto Reset	Control panel heating / cooling control is disabled
UI12 sensor failure	Auto Reset	Warning
cpCOe #1 UI3 sensor failure	Auto Reset	Warning
cpCOe #1 Offline Alarm	Auto Reset	Warning
cpCOe #1 wrong config Alarm	Auto Reset	Warning
cpCOe #2 UI1 sensor failure	Auto Reset	Modules switch into Stand-alone Mode ^(d)
cpCOe #2 UI2 sensor failure	Auto Reset	Modules switch into Stand-alone Mode ^(d)
cpCOe #2 UI3 sensor failure	Auto Reset	Modules switch into Stand-alone Mode ^(d)
cpCOe #2 UI4 sensor failure	Auto Reset	Modules switch into Stand-alone Mode ^(d)
cpCOe #2 UI7 sensor failure	Auto Reset	Switches from Remote SP to Local if used
cpCOe #2 UI8 sensor failure	Auto Reset	Switches from Remote SP to Local if used
cpCOe #2 Offline Alarm	Auto Reset	Modules switch into Stand-alone Mode ^(d)
cpCOe #2 wrong config Alarm	Auto Reset	Warning

Table 15. Interface panel diagnostic code key (continued)

Compressor 1 External Fault	Auto Reset	Shuts down compressor 1
CoreSense 1 Warning	Auto Reset	Warning
CoreSense 1 Fault	User Reset	Shuts down compressor 1
CoreSense 1 Failure	User Reset	Shuts down compressor 1
CoreSense 1 Lockout	User Reset	Shuts down Circuit 1
CoreSense 1 Offline	Auto Reset	Shuts down compressor 1
Compressor 2 External Fault	Auto Reset	Shuts down compressor 2
CoreSense 2 Warning	Auto Reset	Warning
CoreSense 2 Fault	User Reset	Shuts down compressor 2
CoreSense 2 Failure	User Reset	Shuts down compressor 2
CoreSense 2 Lockout	User Reset	Shuts down Circuit 2
CoreSense 2 Offline	Auto Reset	Shuts down compressor 2
ABB VFD 1 Warning	Auto Reset	Warning
ABB VFD 1 Fault	User Reset	Shuts down compressor 1
ABB VFD 1 Lockout	User Reset	Shuts down compressor 1
ABB VFD 1 Offline	Auto Reset	Shuts down compressor 1
ABB VFD 2 Warning	Auto Reset	Warning
ABB VFD 2 Fault	User Reset	Shuts down compressor 2
ABB VFD 2 Lockout	User Reset	Shuts down compressor 2
ABB VFD 2 Offline	Auto Reset	Shuts down compressor 2
Evaporator Freezing Alarm	User Reset	Locks out module
Phase Monitor Alarm	Auto Reset	Shuts down chiller bank ^(e)
Evaporator Flow Alarm	User Reset	Locks out module ^(f)
	User Reset	Shuts down Circuits ^(g)
Condenser Flow Alarm	User Reset	Shuts down Circuits/Circuit 1 ^(g)
HP Alarm	User Reset	Shuts down Circuit 1/2
HP Switch Alarm	Auto Reset	Shuts down Circuit 1/2
LP Alarm	Auto Reset	Shuts down Circuit 1/2
LP Lockout Alarm	User Reset	Shuts down Circuit 1/2
Secondary 1 communication lost	Auto Reset	Warning
Secondary 2 communication lost	Auto Reset	Warning
Secondary 3 communication lost	Auto Reset	Warning
Secondary 4 communication lost	Auto Reset	Warning
Secondary 5 communication lost	Auto Reset	Warning
Secondary 6 communication lost	Auto Reset	Warning
Secondary 7 communication lost	Auto Reset	Warning



Chiller Troubleshooting

Table 15. Interface panel diagnostic code key (continued)

Secondary 8 communication lost	Auto Reset	Warning
Secondary 9 communication lost	Auto Reset	Warning
Secondary 10 communication lost	Auto Reset	Warning
Secondary 11 communication lost	Auto Reset	Warning
Primary communication lost	Auto Reset	Secondary Modules switch into Stand-alone Mode
BMS offline	Auto Reset	Warning
System Chilled LWT too high	Auto Reset	Warning
System Hot LWT too low	Auto Reset	Warning
Condenser LWT too low	Auto Reset	Warning
Evaporator LWT too high	Auto Reset	Warning
Error in the number of retain memory writings	User Reset	Warning
Error in retain memory writings	User Reset	Warning
Wrong Primary rotation control parameters	Auto Reset	Warning
Wrong temperature control parameters	Auto Reset	Warning
Circuit 1 Differential Pressure low	Auto Reset	Warning
Circuit 2 Differential Pressure low	Auto Reset	Warning
Low Differential Pressure Lockout	User Reset	If Circuit 1/2 Low DP Warnings occurred
No Available Modules	Auto Reset	Warning
Evaporator Pumps Offline	Auto Reset	Warning ^(h)
Condenser Pumps Offline	Auto Reset	Warning ^(h)
Compressor 1 Short-cycling	Auto Reset	Warning
Compressor 1 Short-cycling Lockout	User Reset	Locks out compressor 1
Compressor 2 Short-cycling	Auto Reset	Warning
Compressor 2 Short-cycling Lockout	User Reset	Locks out compressor 2
Circuit 1 Evacuation Cycle	Auto Reset	Warning
Circuit 2 Evacuation Cycle	Auto Reset	Warning

(a) If Low Pressure sensor selected for Suction Pressure Alarm.

(b) If Module is in Stand-alone Mode and respective Entering/Leaving Water sensor selected for Temperature Control.

(c) For models with integrated Free Cooling.

(d) If both respective Cooling/Heating Mode selected and respective Entering/Leaving Water sensor selected for Temperature Control.

(e) If a single Phase Monitor per chiller bank selected.

(f) For Variable Flow systems.

(g) For Constant Flow systems.

(h) If Evaporator/Condenser Pumps Module used.

Compressor Diagnostic Codes

Some Copeland compressors used in Trane chillers are highly automated with digital capability to record and report a range of operating parameters and critical events. This technology can be employed to assist in troubleshooting compressor faults and potential corrective action.

CoreSense™ Flash Codes

If equipped, the CoreSense technology in Copeland compressor will communicate an abnormal system condition through a unique flash code:

The flash code number corresponds to the number of LED flashes, followed by a pause, and then the flash code is repeated.

A lockout condition produces a red flash, followed by a pause, a solid red, a second pause, and then repeated.

Table 16. CoreSense™ communications LED flash code information

Status	Fault Condition	Code Fault Description	Code Reset Description	Trouble Shooting Information
Solid Green	Normal Operation	Module is powered and operation is normal	N/A	N/A
Solid Red	Module Malfunction	Module has internal fault	N/A	<ol style="list-style-type: none"> Reset module by removing power from T2-T1 Replace module
Warning LED Flash				
Green Flash Code 1	Loss of Communication	Module and master controller have lost communications with each other for more than 5 minutes	When communications are confirmed	<ol style="list-style-type: none"> Check the control wiring Verify dipswitch 8 is "on"
Green Flash Code 2	Future Use	N/A	N/A	N/A
Green Flash Code 3	Short Cycling	Run time of less than 3 minutes; number of short cycles exceeds 48 in 24 hours	< 48 short cycles in 24 hours	<ol style="list-style-type: none"> Check system charge and pressure control setting. Adjust set-point of temperature controller. Install anti-short cycling control.
Green Flash Code 4	Open/Shorted Scroll Thermistor	$\Omega > 370K$ or $\Omega < 1K$	$5.1K < \Omega < 370K$	<ol style="list-style-type: none"> Check for poor connections at module and thermistor fuseite. Check continuity of thermistor wiring harness.
Green Flash Code 5	Future Use	N/A	N/A	N/A
Alert/Lockout LED Flash				
Red Flash Code 1	Motor High Temperature	$\Omega > 4.5K \pm 25\%$;	$\Omega < 2.75K$ and 30 minutes	<ol style="list-style-type: none"> Check supply voltage. Check system charge and superheat. Check contactor
Red Flash Code 2	Open/Shorted Motor Thermistor	$\Omega > 220K$ or $\Omega < 40$;	$40 < \Omega < 2.75K$ and 30	<ol style="list-style-type: none"> Check for poor connections at module and thermistor fuseite. Check continuity of thermistor wiring harness.
Red Flash Code 3	Short Cycling	Run time of less than 3 minutes; Lockout if the number of Alerts exceeds the number configured by the user in 24 hours	Interrupt power to T2-T1 or perform	<ol style="list-style-type: none"> Check system charge and pressure control setting. Adjust set-point of temperature controller. Install anti-short cycling control.
Red Flash Code 4	Scroll High Temperature	$\Omega < 2.4K$; Lockout if the number of Alerts exceeds the number configured by the user in 24 hours	Interrupt power to T2-T1 or perform Modbus reset command	<ol style="list-style-type: none"> Check system charge and superheat. Check system operating conditions Check for abnormally low suction pressure

Chiller Troubleshooting

Table 16. CoreSense™ communications LED flash code information (continued)





Status	Fault Condition	Code Fault Description	Code Reset Description	Trouble Shooting Information
Red Flash Code 5	Future Use	N/A	N/A	N/A
Red Flash Code 6	Missing Phase	Missing phase	After 5 minutes and missing phase condition is not present	<ol style="list-style-type: none"> 1. Check incoming power. 2. Check fuses/breakers. 3. Check contactor.
Red Flash Code 7	Reverse Phase	Reverse phase; Lockout after 1 Alert	Interrupt power to T2-T1 or perform	<ol style="list-style-type: none"> 1. Check incoming phase sequence. 2. Check contactor. 3. Check module phasing wires A-B-C.
Red Flash Code 8	Future Use	N/A	N/A	N/A
Red Flash Code 9	Module Low Voltage	Low voltage on T2-T1 terminals ¹	After 5 minutes and the voltage is back in the normal range	<ol style="list-style-type: none"> 1. Verify correct module p/n. 2. Check VA rating of transformer. 3. Check for blown fuse in transformer secondary.

Phase Monitor Protection

If the chiller fails to power up, eliminate electrical phase issues by inspecting the phase monitor device located in the power distribution panel.

When all voltages are acceptable and the phase sequence is correct the output relay is energized and the LED glows green. Under-voltages and unbalanced voltages must be sensed for a continuous trip delay period before the relay de-energizes. Reset is automatic upon correction of the fault condition. The output relay will not energize if a fault condition is sensed as power is applied. The LED flashes red during the trip delay, then glows red when the output de-energizes. The LED flashes green/red if phase reversal is sensed.

Table 17. LED phase monitor diagnostic codes

LED Display	Indication
	Glowing green: All voltages are acceptable and phase sequence is correct.
	Flashing red: Trip delay prior to de-energizing. Glowing red: Output has been de-energized upon fault detection.
	Flashing red and green: Phase reversal is detected.
	No power to phase monitor.

If the phase monitor fails to energize (the LED glows red), check wiring of all three phases, voltage, and phase sequence. If phase sequence is incorrect, the LED flashes green/red. To correct this, swap any two line voltage connections at the mounting socket. No further adjustment should be required.

Symptoms and Solutions

This section lists the most common troubleshooting symptoms and the closest potential solution for each. This is not an exhaustive listing of all potential causes or resolutions, but represents the best direction in which to initiate a solution.

Note: An anti-short cycle timer is included in the primary microprocessor controller to prevent the compressors from starting until the delay has elapsed. The microprocessor also provides minimum compressor run timers. Take these fixed timer parameters into consideration when conducting a fault isolation process.

1. Symptom: Compressor will not start	
Possible Causes	Potential Solutions
Temperature control not in demand	Set point has been reached.
Flow switch open due to low water flow	Check flow switch functionality; check flow rate.
Low pressure, high pressure sensor open	Low/high pressure event has occurred; obstructed BPHE or coil; check fan settings and functionality; check sensor functionality.
High pressure switch open	High pressure event has occurred; check fan settings and functionality; check obstructed coils; check pressure switch functionality.
Compressor overload opened	Allow motor to cool and reset; high amp load/floodback; compressor operating outside of operating envelope.
No power to module	Check breakers and fuses; energize from module electrical and control panel.
Phase monitor open or tripped	Check phase sequence, unbalanced voltage, overvoltage, undervoltage; loss of phase.
Breaker tripped	Reset breaker; check amp draw, high refrigeration pressure, low voltage, and loose connection.

2. Symptom: Compressor will not run	
Possible Causes	Potential Solutions
Breakers or switches are off	Assure all breakers and switches are on.
Main switch open or circuit breakers open	Check circuits and motor winding for shorts or grounds.
Fuse is blown	Replace fuse or reset breakers after fault is corrected.
Investigate for possible overloading	Overloads are auto-reset. Monitor to assure the overload does not re-occur.
Defective contactor or coil	Determine type and cause. Correct fault before resetting safety.
Liquid line solenoid will not open	Check motor for open circuit, short circuit, or motor burnout.

3. Symptom: Compressor has excessive noise or vibration	
Possible Causes	Potential Solutions
Flooding of refrigerant into crankcase	Check setting of expansion valve; check crankcase heater.
Faulty crankcase heater	Replace crankcase heater.
Improper or worn compressor support	Replace support.
Worn compressor	Replace or rebuild compressor.
Improper phase sequence	Check phase sequence.

4. Symptom: Compressor Loading/Unloading Cycles Too Short	
Possible Causes	Potential Solutions
Temperature differential set too low	Ramp/set temperature differential setpoint; check stage up/down settings.
Incorrect liquid temperature settings	Select proper control settings.
Insufficient evaporator water flow	Adjust flow rate.

5. Symptom: Compressor loses oil	
Possible Causes	Potential Solutions
Low refrigerant charge	Check for leaks and repair. Add refrigerant to proper charge.
Defective crankcase heater	Replace crankcase heater.



Chiller Troubleshooting

5. Symptom: Compressor loses oil	
Possible Causes	Potential Solutions
Oil trapped in line	Low refrigerant velocity caused by operation outside operating envelope.
Compressor short cycling	Adjust proper control settings for Min. ON/OFF runtime.
Liquid refrigerant	Check compressor superheat. Superheat at the compressor suction should be approximately 12°F (8.3°C).

6. Symptom: Low refrigeration suction pressure	
Possible Causes	Potential Solutions
Lack of refrigerant	Check for leaks. Repair and add charge.
Evaporator dirty	Clean with chemical.
Suction line blockage	Check suction line for any obstacle.
Condensing temperature too low	Check fan settings.
Low water temperature	Raise set point; check design specification.
Incorrect fan speed	Check fan settings.
Low discharge pressure	Refrigerant charge; replace compressor, check fan settings.
Improper expansion valve settings	Check EXV functionality and settings.
Mis-adjusted or defective TXV	Adjust or replace valve.
Receiver service valve closed	Turn counterclockwise completely. Do not fully backseat if pressure switch is installed on service port.
Clogged liquid line filter-drier	Replace filter drier or cartridges.
Excessive glycol concentration	Charge to proper glycol concentration.
Liquid line solenoid restricted or faulty	Replace solenoid valve, coil, or internals as necessary.
Insufficient chilled water	Adjust flow rate through evaporator.
Restricted water/glycol line	Clean strainers; check manual and electronic valves.
Water/glycol mixture contaminated	Intensive cleanup effort needed to identify source of contamination; external filter may be required.
Evaporator clogged or fouled	Reverse flush with appropriate chemical solutions.

7. Symptom: High refrigeration suction pressure	
Possible Causes	Potential Solutions
Expansion valve opened too far	Re-adjust to 10° to 12°.
Excessive refrigerant charge	Creates high pressure alarms; reclaim excess refrigerant and verify proper sub-cooling and superheat.
High water temperature	Low refrigerant charge; failing compressor; check design specifications.

8. Symptom: Low refrigerant discharge pressure	
Possible Causes	Potential Solutions
Insufficient refrigerant in chiller	Check for leaks. Repair and add refrigerant as needed.
Faulty compressor	Check compressor.
Low ambient conditions	Check condenser rating tables.
Low suction pressure	See "low refrigeration suction pressure".

8. Symptom: Low refrigerant discharge pressure	
Possible Causes	Potential Solutions
Condenser pressure regulating valve not properly functioning (if provided)	Replace condenser head pressure control valve (if installed).
Incorrect fan control settings	Check fan settings.

9. Symptom: High refrigerant discharge pressure	
Possible Causes	Potential Solutions
System overcharged with refrigerant	Remove excess refrigerant.
Dirty tube and fin surface	Clean with compressed air or water spray, use fin comb if fins are bent.
Non-condensables in chiller	Purge non-condensables.
Incorrect fan control settings	Check fan functionality and settings.
Condensing fans not operating	Check fan functionality and settings.
EXV/TXV does not function properly	Check EXV/TXV functionality; Check SSH settings.
High ambient conditions exist	Check condenser rating tables with operating parameters.

10. Symptom: Low chilled water temperature	
Possible Causes	Potential Solutions
Temperature controllers set too low	Reset temperature controllers to correct design specifications.
Low water flow	Clean strainer; Check pump, VFD, and differential pressure settings; Check to confirm electric and manual water valves are fully open.
Faulty system temperature sensor	Replace temperature sensor.

11. Symptom: High chilled water temperature	
Possible Causes	Potential Solutions
Load higher than capacity of chiller	Refer to chiller design specifications.
Loss of refrigeration charge	Check refrigerant charge.
Fouled evaporator	Reverse flush evaporator; check strainer for debris.
High water flow rate	Check pump, VFD, and differential pressure settings.
Faulty system temperature sensor	Replace temperature sensor.

12. Symptom: Compressor thermal protector switch open	
Possible Causes	Potential Solutions
Operating beyond design conditions	Check fan switch or fan pressure settings as appropriate.
Discharge valve partially shut	Open valve.
Faulty compressor overload	Replace overload if external type provided.

13. Symptom: No low voltage (24 Vac)	
Possible Causes	Potential Solutions
Transformer primary side fuse open	Check fuse prong contact points; replace fuse.
Transformer defective	Replace transformer.
No primary voltage on transformer	Check breakers, fuses; check power supply specifications.



Chiller Troubleshooting

14. Symptom: Thermal Expansion valve superheat too high	
Possible Causes	Potential Solutions
Water/glycol temperature too warm	Low refrigerant level; recharge chiller.
Obstructed filter dryer	Replace dryer core.
Low refrigerant charge	Recharge refrigerant as per data plate.
Improperly adjusted superheat valve setting	Reset valve settings to factory specifications.
Sensing bulb incorrectly located	Check if secured to pipe or insulated; check sensor position on pipe.

15. Symptom: Thermal expansion valve superheat too low	
Possible Causes	Potential Solutions
Sensing bulb not properly located	Check if secured to pipe or insulated; check sensor position on pipe.
Defective thermostatic element	Replace power head.
EXV/TXV valve superheat setting is too low or not functioning properly	Check EXV/TXV settings and functionality.

16. Symptom: Contactor/relay inoperative	
Possible Causes	Potential Solutions
Coil shorted or open	Replace coil.
Mechanical parts broken or jammed	Replace assembly.
Contacts pitted or burned	Replace contactors.
No 24 Vac to coil	Replace secondary fuse to transformer; check transformer.

17. Symptom: Freeze protection safety activated	
Possible Causes	Potential Solutions
Chiller setpoint is too low	Use a proper setpoint.
Low water flow	Clean strainer; Check pump, VFD, and differential pressure settings.
Low suction pressure	See "low suction pressure".



Appendix A. Optional Variable Frequency Drive

Thermafit™ AMC modulares are optionally equipped with a Trane TR200 VFD. The lead chiller module or all chiller modules can have a variable speed drive (VSD) on the lead scroll compressor and standard scroll compressor on the lag circuit. The VSD scroll compressor provides smooth

and efficient operation from 45 Hz to 60 Hz for close temperature control. This part load operation can lower the compressor condensing temperatures thereby lowering power consumption during variable load or low cooling load demands.

Figure 28. Trane TR200 variable frequency drive

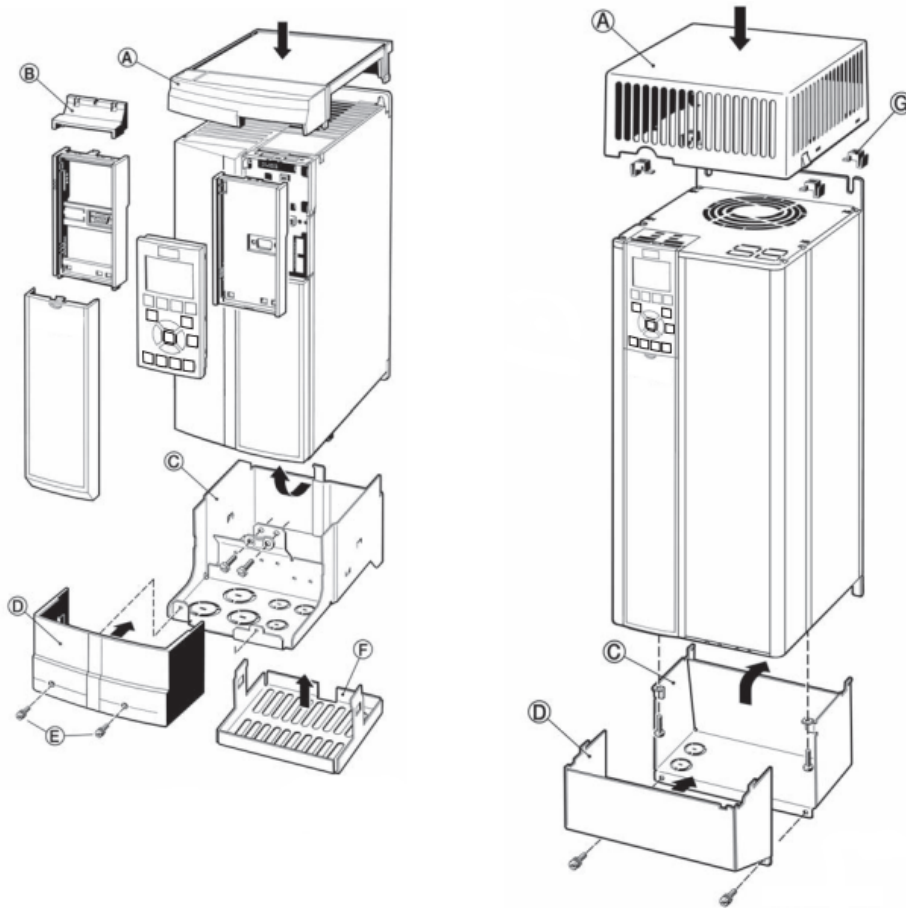

Local Control Panel (LCP)

Local control panel (LCP) is a combined display and keypad on the front of the unit. The LCP is the user interface to the frequency converter.

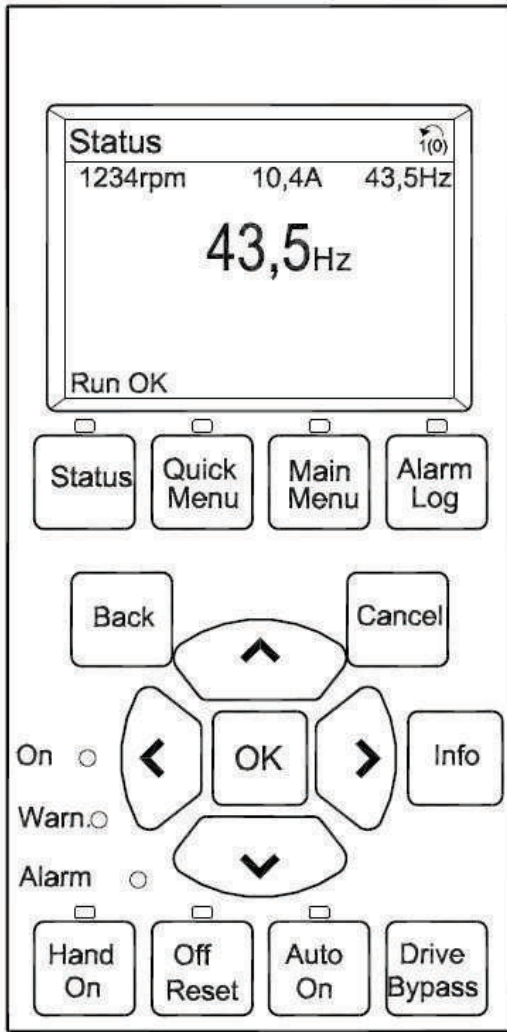

The LCP has several user functions.

- Start, stop, and control speed when in local control.
- Display operational data, status, warnings, and cautions.
- Programming frequency converter functions.
- Manually reset the frequency converter after a fault when auto-reset is inactive.

Warnings and Alarms

The frequency converter monitors the condition of its input power, output, and motor factors as well as other system performance indicators. A warning or alarm may not necessarily indicate a problem internal to the frequency converter itself. In many cases, it indicates failure conditions from input voltage, motor load or temperature, external signals, or other areas monitored by the frequency converter's internal logic. Be sure to investigate those

areas exterior to the frequency converter as indicated in the alarm or warning.

Warnings

A warning is issued when an alarm condition is impending or when an abnormal operating condition is present and may result in the frequency converter issuing an alarm. A warning clears by itself when the abnormal condition is removed.

Alarms/Trips

An alarm is issued when the frequency converter is tripped, that is, the frequency converter suspends operation to prevent frequency converter or system damage. The motor will coast to a stop. The frequency converter logic will continue to operate and monitor the frequency converter status. After the fault condition is remedied, the frequency converter can be reset. It will then be ready to start operation again.

A trip can be reset in any of 4 ways:

- Press (Reset) on the LCP
- Digital reset input command
- Serial communication reset input command
- Auto reset

An alarm that causes the frequency converter to trip-lock requires that input power is cycled. The motor will coast to a stop. The frequency converter logic will continue to operate and monitor the frequency converter status. Remove input power to the frequency converter and correct the cause of the fault, then restore power. This action puts the frequency converter into a trip condition as described above and may be reset in any of those 4 ways.

Warning and Alarm Displays

An alarm or trip-lock alarm will flash on display along with the alarm number. In addition to the text and alarm code on the frequency converter LCP, there are three status indicator lights.

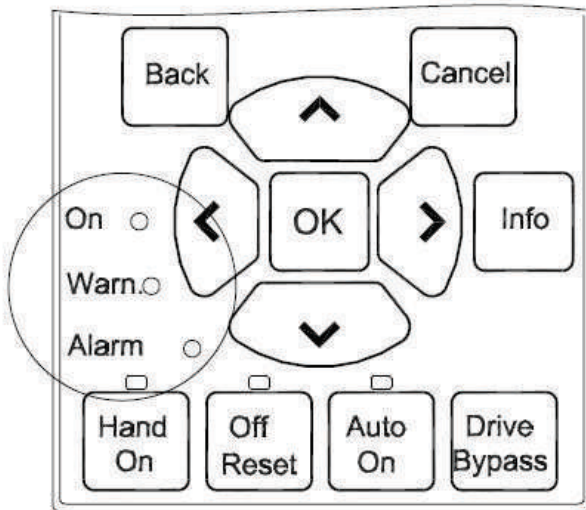

	Warning LED	Alarm LED
Warning	On	Off
Alarm	Off	On (Flashing)
Trip-Lock	On	On (Flashing)

Warning and Alarm Definitions

The warning/alarm information below defines each warning/alarm condition, provides the probable cause for the condition, and details a remedy or troubleshooting procedure.

⚠ WARNING

Hazardous Service Procedures!

Failure to follow all precautions in this manual and on the tags, stickers, and labels could result in death or serious injury.

Technicians, in order to protect themselves from potential electrical, mechanical, and chemical hazards, **MUST** follow precautions in this manual and on the tags, stickers, and labels, as well as the following instructions: Unless specified otherwise, disconnect all electrical power including remote disconnect and discharge all energy storing devices such as capacitors before servicing. Follow proper lockout/tagout procedures to ensure the power can not be inadvertently energized. When necessary to work with live electrical components, have a qualified licensed electrician or other individual who has been trained in handling live electrical components perform these tasks.



Optional Variable Frequency Drive

Table 18. Warning and alarm definitions and troubleshooting

Warning/Alarm	Description / Probable Cause	Troubleshooting
WARNING 1, 10 Volts low	The control card voltage is below 10 V from terminal 50. Remove some of the load from terminal 50, as the 10 V supply is overloaded. Max. 15 mA or minimum 590 Ω. This condition can be caused by a short in a connected potentiometer or improper wiring of the potentiometer.	Remove the wiring from terminal 50. If the warning clears, the problem is with the customer wiring. If the warning does not clear, replace the control card.
WARNING/ALARM 2, Live zero error	This warning or alarm only appears if programmed by the user in 6-01 Live Zero Timeout Function. The signal on one of the analog inputs is less than 50% of the minimum value programmed for that input. Broken wiring or faulty device sending the signal can cause this condition.	<ul style="list-style-type: none"> Check connections on all the analog input terminals. Control card terminals 53 and 54 for signals, terminal 55 common. MCB 101 terminals 11 and 12 for signals, terminal 10 common. MCB 109 terminals 1, 3, 5 for signals, terminals 2, 4, 6 common. Check that the frequency converter programming and switch settings match the analog signal type. Perform Input Terminal Signal Test.
WARNING/ALARM 4, Mains phase loss	A phase is missing on the supply side, or the mains voltage imbalance is too high. This message also appears for a fault in the input rectifier on the frequency converter. Options are programmed at 14-12 Function at Mains Imbalance.	Check the supply voltage and supply currents to the frequency converter.
WARNING 5, DC link voltage high	The intermediate circuit voltage (DC) is higher than the high voltage warning limit. The limit is dependent on the frequency converter voltage rating. The unit is still active.	
WARNING 6, DC link voltage low	The intermediate circuit voltage (DC) is lower than the low voltage warning limit. The limit is dependent on the frequency converter voltage rating. The unit is still active.	
WARNING/ALARM 7, DC overvoltage	If the intermediate circuit voltage exceeds the limit, the frequency converter trips after a time.	<ul style="list-style-type: none"> Connect a brake resistor. Extend the ramp time. Change the ramp type. Activate the functions in 2-10 Brake Function. Increase 14-26 Trip Delay at Inverter Fault. If the alarm/warning occurs during a power sag, the solution is to use kinetic back-up (14-10 Mains Failure).
WARNING/ALARM 8, DC under voltage	If the intermediate circuit voltage (DC link) drops below the under-voltage limit, the frequency converter checks if a 24 VDC backup supply is connected. If no 24 VDC backup supply is connected, the frequency converter trips after a fixed time delay. The time delay varies with unit size.	<ul style="list-style-type: none"> Check that the supply voltage matches the frequency converter voltage. Perform input voltage test. Perform soft charge circuit test.
WARNING/ALARM 9, Inverter overload	The frequency converter is about to cut out because of an overload (too high current for too long). The counter for electronic, thermal inverter protection issues a warning at 98% and trips at 100%, while giving an alarm. The frequency converter cannot be reset until the counter is below 90%. The fault is that the frequency converter has run with more than 100% overload for too long.	<ul style="list-style-type: none"> Compare the output current shown on the LCP with the frequency converter rated current. Compare the output current shown on the LCP with measured motor current. Display the Thermal Drive Load on the LCP and monitor the value. When running above the frequency converter continuous current rating, the counter increases. When running below the frequency converter continuous current rating, the counter decreases.
WARNING/ALARM 10, Motor overload temperature	According to the electronic thermal protection (ETR), the motor is too hot. Select whether the frequency converter issues a warning or an alarm when the counter reaches 100% in 1-90 Motor Thermal Protection. The fault occurs when the motor runs with more than 100% overload for too long.	<ul style="list-style-type: none"> Check for motor overheating. Check if the motor is mechanically overloaded. Check that the motor current set in 1-24 Motor Current is correct. Confirm that Motor data in parameters 1-20 to 1-25 are set correctly. If an external fan is in use, check in 1-91 Motor External Fan that it is selected. Running AMA in 1-29 Automatic Motor Adaptation (AMA) tunes the frequency converter to the motor more accurately and reduces thermal loading.

Table 18. Warning and alarm definitions and troubleshooting (continued)

Warning/Alarm	Description / Probable Cause	Troubleshooting
WARNING/ALARM 11, Motor thermistor over temp	Check whether the thermistor is disconnected. Select whether the frequency converter issues a warning or an alarm in 1-90 Motor Thermal Protection	<ul style="list-style-type: none"> • Check for motor overheating. • Check if the motor is mechanically overloaded. • When using terminal 53 or 54, check that the thermistor is connected correctly between either terminal 53 or 54 (analog voltage input) and terminal 50 (+10 V supply). Also check that the terminal switch for 53 or 54 is set for voltage. • Check 1-93 Thermistor Source selects terminal 53 or 54. • When using digital inputs 18 or 19, check that the thermistor is connected correctly between either terminal 18 or 19 (digital input PNP only) and terminal 50. Check 1-93 Thermistor Source selects terminal 18 or 19.
WARNING/ALARM 12, Torque limit	The torque has exceeded the value in 4-16 Torque Limit Motor Mode or the value in 4-17 Torque Limit Generator Mode. 14-25 Trip Delay at Torque Limit can change this from a warning only condition to a warning followed by an alarm.	<ul style="list-style-type: none"> • If the motor torque limit is exceeded during ramp up, extend the ramp up time. • If the generator torque limit is exceeded during ramp down, extend the ramp down time. • If torque limit occurs while running, possibly increase the torque limit. Make sure that the system can operate safely at a higher torque. • Check the application for excessive current draw on the motor.
WARNING/ALARM 13, Over current	The inverter peak current limit (approximately 200% of the rated current) is exceeded. The warning lasts about 1.5 s, then the frequency converter trips and issues an alarm. This fault can be caused by shock loading or quick acceleration with high inertia loads. It can also appear after kinetic back-up if the acceleration during ramp up is quick. If extended mechanical brake control is selected, trip can be reset externally.	<ul style="list-style-type: none"> • Remove power and check if the motor shaft can be turned. • Check that the motor size matches the frequency converter. • Check parameters 1-20 to 1-25 for correct motor data.
ALARM 14, Earth (ground) fault	There is current from the output phases to earth, either in the cable between the frequency converter and the motor or in the motor itself.	<ul style="list-style-type: none"> • Remove power to the frequency converter and repair the earth fault. • Check for earth faults in the motor by measuring the resistance to ground of the motor leads and the motor with a megohmmeter.
ALARM 15, Hardware mismatch	A fitted option is not operational with the present control board hardware or software.	<p>Record the value of the following parameters and contact your Trane supplier:</p> <ul style="list-style-type: none"> • 15-40 FC Type • 15-41 Power Section • 15-42 Voltage • 15-43 Software Version • 15-45 Actual Typecode String • 15-49 SW ID Control Card • 15-50 SW ID Power Card • 15-60 Option Mounted • 15-61 Option SW Version (for each option slot)
ALARM 16, Short circuit	There is short-circuiting in the motor or motor wiring.	Remove power to the frequency converter and repair the short circuit.
WARNING/ALARM 17, Control word timeout	There is no communication to the frequency converter. The warning is only active when 8-04 Control Timeout Function is NOT set to [0] Off. If 8-04 Control Timeout Function is set to [5] Stop and Trip, a warning appears, and the frequency converter ramps down until it stops then displays an alarm.	<ul style="list-style-type: none"> • Check connections on the serial communication cable. • Increase 8-03 Control Timeout Time. • Check the operation of the communication equipment. • Verify a proper installation based on EMC requirements.
ALARM 18, Start failed	The speed has not been able to exceed 1-77 Compressor Start Max Speed [RPM] during start within the allowed time (set in 1-79 Compressor Start Max Time to Trip). This may be caused by a blocked motor.	



Optional Variable Frequency Drive

Table 18. Warning and alarm definitions and troubleshooting (continued)

Warning/Alarm	Description / Probable Cause	Troubleshooting
WARNING 23, Internal fan fault	The fan warning function is an extra protective function that checks if the fan is running/ mounted. The fan warning can be disabled in 14-53 Fan Monitor ([0] Disabled). For the D, E, and F Frame filters, the regulated voltage to the fans is monitored.	<ul style="list-style-type: none"> • Check for proper fan operation. • Cycle power to the frequency converter and check that the fan operates briefly at start-up. • Check the sensors on the heatsink and control card.
WARNING 24, External fan fault	The fan warning function is an extra protective function that checks if the fan is running/ mounted. The fan warning can be disabled in 14-53 Fan Monitor ([0] Disabled).	
WARNING/ALARM 28, Brake check failed	The brake resistor is not connected or not working.	Check 2-15 Brake Check.
ALARM 29, Heatsink temp	The maximum temperature of the heatsink has been exceeded. The temperature fault will not reset until the temperature falls below a defined heatsink temperature. The trip and reset points are different based on the frequency converter power size.	<p>Check for the following conditions.</p> <ul style="list-style-type: none"> • Ambient temperature too high. • Motor cable too long. • Incorrect airflow clearance above and below the frequency converter. • Blocked airflow around the frequency converter. • Damaged heatsink fan. • Dirty heatsink.
ALARM 30, Motor phase U missing	Motor phase U between the frequency converter and the motor is missing.	<ul style="list-style-type: none"> • Remove power from the frequency converter and check motor phase U. • Remove power from the frequency converter and check motor phase V. • Remove power from the frequency converter and check motor phase W. • Let the unit cool to operating temperature.
ALARM 31, Motor phase V missing	Motor phase V between the frequency converter and the motor is missing.	Remove power from the frequency converter and check motor phase V.
ALARM 32, Motor phase W missing	Motor phase W between the frequency converter and the motor is missing.	Remove power from the frequency converter and check motor phase W.
ALARM 33, Inrush fault	Too many power-ups have occurred within a short time period.	Let the unit cool to operating temperature.
WARNING/ALARM 34, Fieldbus communication fault	The fieldbus on the communication option card is not working.	
WARNING/ALARM 36, Mains failure	This warning/alarm is only active if the supply voltage to the frequency converter is lost and 14-10 Mains Failure is NOT set to [0] No Function.	Check the fuses to the frequency converter and mains power supply to the unit.
ALARM 38, Internal fault	When an internal fault occurs, a code number defined in Table 8.3 is displayed.	<ul style="list-style-type: none"> • Cycle power. • Check that the option is properly installed. • Check for loose or missing wiring. • It may be necessary to contact your Trane supplier or service department. Note the code number for further troubleshooting directions.
ALARM 39, Heatsink sensor	No feedback from the heatsink temperature sensor. The signal from the IGBT thermal sensor is not available on the power card. The problem could be on the power card, on the gate drive card, or the ribbon cable between the power card and gate drive card.	
WARNING 40	Overload of digital output terminal 27	Check the load connected to terminal 27 or remove short circuit connection. Check 5-01 Terminal 27 Mode.
WARNING 41	Overload of digital output terminal 29	Check the load connected to terminal 29 or remove short circuit connection. Check 5-02 Terminal 29 Mode.

Table 18. Warning and alarm definitions and troubleshooting (continued)

Warning/Alarm	Description / Probable Cause	Troubleshooting
WARNING 42	Overload of digital output on X30/6 or overload of digital output on X30/7.	<ul style="list-style-type: none"> For X30/6, check the load connected to X30/6 or remove the short-circuit connection. Check 5-32 Term X30/6 Digi Out (MCB 101). For X30/7, check the load connected to X30/7 or remove the short-circuit connection. Check 5-33 Term X30/7 Digi Out (MCB 101).
ALARM 45 Earth fault 2	Earth (ground) fault on start-up.	<ul style="list-style-type: none"> Check for proper earthing (grounding) and loose connections. Check for proper wire size. Check motor cables for short-circuits or leakage currents.
ALARM 46, Power card supply	The supply on the power card is out of range. There are three power supplies generated by the switch mode power supply (SMPS) on the power card: 24 V, 5 V, ±18 V. When powered with 24 VDC with the MCB 107 option, only the 24 V and 5 V supplies are monitored. When powered with three phase mains voltage, all three supplies are monitored.	<ul style="list-style-type: none"> Check for a defective power card. Check for a defective control card. Check for a defective option card. If a 24 VDC power supply is used, verify proper supply power.
WARNING 47 24 V supply low	The 24 VDC is measured on the control card.	
WARNING 48 1.8 V supply low	The 1.8 VDC supply used on the control card is outside of allowable limits. The power supply is measured on the control card.	Check for a defective control card. If an option card is present, check for an overvoltage condition.
WARNING 49, Speed limit	When the speed is not within the specified range in 4-11 Motor Speed Low Limit [RPM] and 4-13 Motor Speed High Limit [RPM], the frequency converter shows a warning. When the speed is below the specified limit in 1-86 Trip Speed Low [RPM] (except when starting or stopping) the frequency converter will trip.	
ALARM 50, AMA calibration failed		Contact your Trane supplier or Trane Service Department
ALARM 51, AMA check Unom and Inom	The settings for motor voltage, motor current and motor power are wrong.	Check the settings in parameters 1-20 to 1-25.
ALARM 52, AMA low Inom	The motor current is too low.	Check the settings.
ALARM 53, AMA motor too big	The motor is too big for the AMA to operate.	
ALARM 54, AMA motor too small	The motor is too small for the AMA to operate.	
ALARM 55, AMA parameter out of range	The parameter values of the motor are outside of the acceptable range. AMA will not run.	
ALARM 56, AMA interrupted by user	The user has interrupted the AMA.	
ALARM 57, AMA internal fault		Try to restart AMA again. Repeated restarts can overheat the motor.
ALARM 58, AMA Internal fault		Contact your Trane supplier.
WARNING 59, Current limit	The current is higher than the value in 4-18 Current Limit.	Confirm that Motor data in parameters 1-20 to 1-25 are set correctly. Possibly increase the current limit. Be sure that the system can operate safely at a higher limit.
WARNING 60, External interlock	A digital input signal is indicating a fault condition external to the frequency converter. An external interlock has commanded the frequency converter to trip.	Clear the external fault condition. To resume normal operation, apply 24 Vdc to the terminal programmed for external interlock. Reset the frequency converter.



Optional Variable Frequency Drive

Table 18. Warning and alarm definitions and troubleshooting (continued)

Warning/Alarm	Description / Probable Cause	Troubleshooting
WARNING 62, Output frequency at maximum limit	The output frequency has reached the value set in 4-19 Max Output Frequency.	Check the application to determine the cause. Possibly increase the output frequency limit. Be sure the system can operate safely at a higher output frequency. The warning will clear when the output drops below the maximum limit.
WARNING/ALARM 65, Control card over temperature	The cut-out temperature of the control card is 80 °C.	<ul style="list-style-type: none"> • Check that the ambient operating temperature is within limits. • Check for clogged filters. • Check fan operation. • Check the control card.
WARNING 66, Heatsink temperature low	The frequency converter is too cold to operate. This warning is based on the temperature sensor in the IGBT module.	Increase the ambient temperature of the unit. Also, a trickle amount of current can be supplied to the frequency converter whenever the motor is stopped by setting 2-00 DC Hold/Preheat Current at 5% and 1-80 Function at Stop
ALARM 67, Option module configuration has changed	One or more options have either been added or removed since the last power-down.	Check that the configuration change is intentional and reset the unit.
ALARM 69, Power card temperature	The temperature sensor on the power card is either too hot or too cold	<ul style="list-style-type: none"> • Check that the ambient operating temperature is within limits. • Check for clogged filters. • Check fan operation. • Check the power card.
ALARM 70, Illegal FC configuration	The control card and power card are incompatible.	Contact your supplier with the type code of the unit from the nameplate and the part numbers of the cards to check compatibility.
ALARM 78, Tracking error Drive initialized to default value	Parameter settings are initialized to default settings after a manual reset.	Reset the unit to clear the alarm.
ALARM 92, No flow	A no-flow condition has been detected in the system. 22-23 No-Flow Function is set for alarm.	Troubleshoot the system and reset the frequency converter after the fault has been cleared.
ALARM 93, Dry pump	A no-flow condition in the system with the frequency converter operating at high speed may indicate a dry pump. AP-26 Dry Pump Function is set for alarm.	Troubleshoot the system and reset the frequency converter after the fault has been cleared.
ALARM 94, End of curve	Feedback is lower than the set point. This may indicate leakage in the system. 22-50 End of Curve Function is set for alarm.	Troubleshoot the system and reset the frequency converter after the fault has been cleared.
ALARM 95, Broken belt	Torque is below the torque level set for no load, indicating a broken belt. 22-60 Broken Belt Function is set for alarm.	Troubleshoot the system and reset the frequency converter after the fault has been cleared.
ALARM 96, Start delayed	Motor start has been delayed due to short-cycle protection. 22-76 Interval between Starts is enabled.	Troubleshoot the system and reset the frequency converter after the fault has been cleared.
WARNING 97, Stop delayed	Stopping the motor has been delayed due to short cycle protection. 22-76 Interval between Starts is enabled.	Troubleshoot the system and reset the frequency converter after the fault has been cleared.
WARNING 98, Clock fault	Time is not set or the RTC clock has failed.	Reset the clock in 0-70 Date and Time.
WARNING 200, Fire mode	This warning indicates the frequency converter is operating in fire mode. The warning clears when fire mode is removed.	See the fire mode data in the alarm log.
WARNING 201, Fire mode was active	This indicates the frequency converter had entered fire mode.	Cycle power to the unit to remove the warning. See the fire mode data in the alarm log.
WARNING 202, Fire mode limits exceeded	While operating in fire mode one or more alarm conditions have been ignored which would normally trip the unit. Operating in this condition voids unit warranty.	Cycle power to the unit to remove the warning. See the fire mode data in the alarm log.

Table 18. Warning and alarm definitions and troubleshooting (continued)

Warning/Alarm	Description / Probable Cause	Troubleshooting
WARNING 203, Missing motor	With a frequency converter operating multi-motors, an under-load condition was detected. This could indicate a missing motor.	Inspect the system for proper operation.
WARNING 204, Locked rotor	With a frequency converter operating multi-motors, an overload condition was detected. This could indicate a locked rotor.	Inspect the motor for proper operation.
WARNING 250, New spare part	A component in the frequency converter has been replaced.	Reset the frequency converter for normal operation.
WARNING 251, New typecode	The power card or other components have been replaced and the typecode changed.	Reset to remove the warning and resume normal operation.

Appendix B. Optional Tank and Pump Module

Tank and Pump Components

A tank and pump module typically contains dual lead/lag pumps and an expansion tank. If the chiller fluid is glycol, there will be a glycol feeder consisting of a vented reservoir and charging pump. The charging pump maintains the system pressure at 12 psi by sensing the pump suction pressure.

A sealed stainless steel storage tank can also be provided in lieu of an expansion tank. With a pressurized tank there is no requirement for an additional expansion tank as it uses trapped air in the fluid system to allow system expansion. An air separator is not recommended in a fluid system with a pressurized tank because without the trapped air, the system expansion characteristics of the

tank could not be exploited. The sealed tank also contains a vacuum vent to protect the tank from imploding.

Dual lead/lag pumps, each with 100% pumping capacity, are provided in each tank and pump module. If the lead pump fails to operate, the lag pump activates and an alarm signal is generated on the microprocessor controller indicating primary pump failure. Under normal system operation, each pump rotates as the lead pump every 168 hours of system operation. Pump motors can be equipped with variable frequency drives (VFDs) for variable flow operation. For the system to operate with variable flow, each heat recovery chiller module must have electronic modulating valves.

Switches inside the pump module control panel start each pump. Confirm that the each pump rotates clockwise and the pressure drop across the system is as expected.

Figure 29. Typical tank and pump module layout

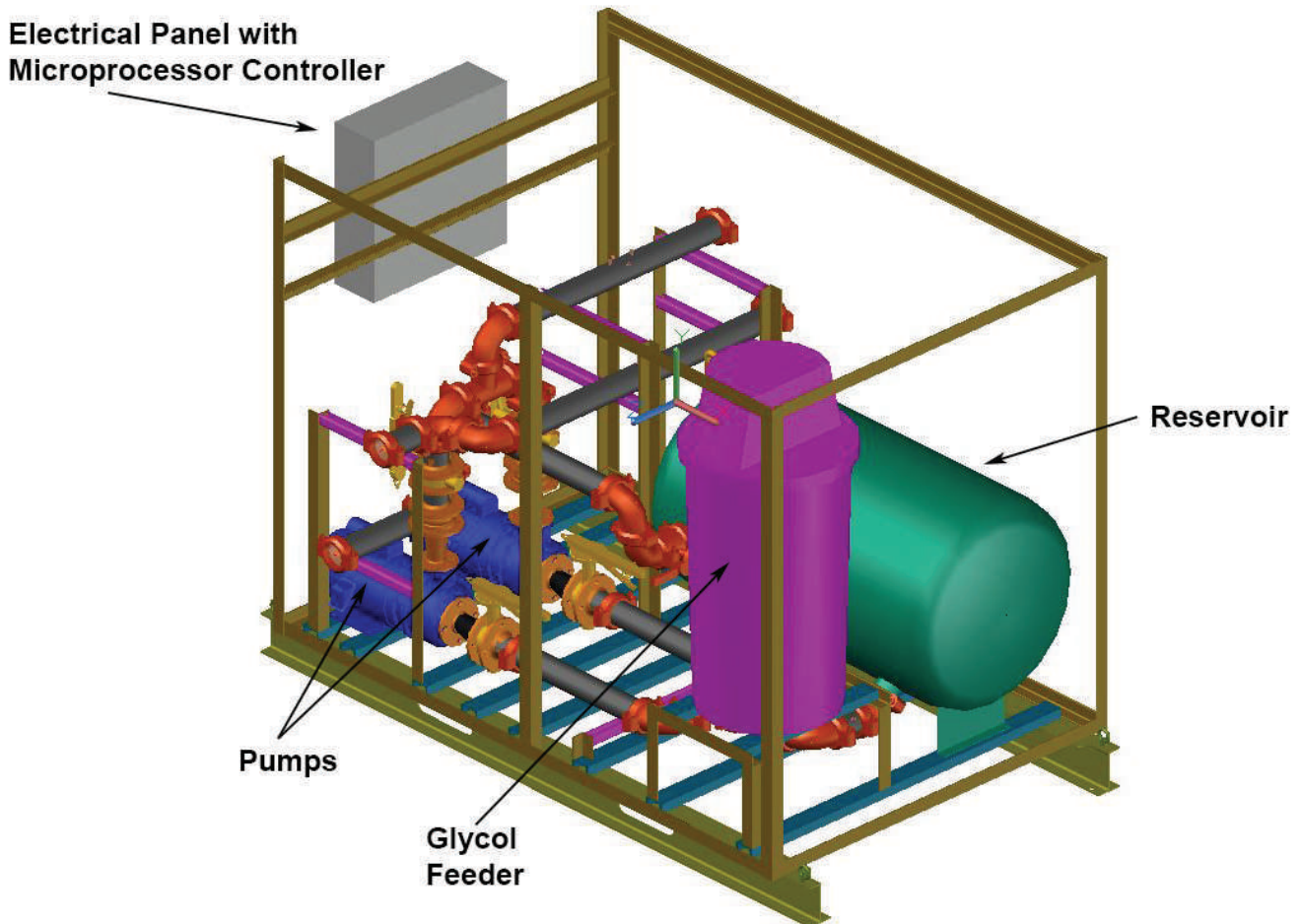

Fill the Storage Tank

The tank and pump module may contain a pressurized storage tank. The tank is pressurized during operation and maintains pressure when the chiller is turned off. The tank also has a vacuum vent to prevent the tank imploding.

1. Turn off the pump using the two switches on the electrical and control panel.
2. Bleed any air pressure in the tank by pressing the vacuum vent valve on the top of the tank. The storage tank has a float-type tank level switch; if the level falls below a factory-set point, an alarm will activate.
3. Open the tank fill port valve and fill the tank.

NOTICE

Equipment Damage!

Do not permanently connect the water fill port to a water supply.

If the chiller uses glycol, plain water entry into the chiller could dilute the glycol concentration and lead to system failure due to freezing.

4. Confirm that both the front fill port and service valve remain closed during operation.
5. The pressure relief valve is set to 100 psi to prevent over-pressurizing the tank.

Variable Flow Tank and Pump Module Sequence of Operations

5. Since the electronic isolation valve of the primary module is already energized, the pump must produce the minimum flow required by the primary module. A system bypass with valve must be provided by the customer and installed externally from the chiller at the most remote fan coil or device to ensure that the pump can provide the minimum flow required through the primary module, if the return flow to chillers could be completely restricted with all fan coils or devices isolated (a high-quality pressure-independent valve is recommended for this bypass so as to provide accurate bypass control regardless of system pressure differential between supply and return headers).
6. Once this minimum flow is established and the system demand (based on leaving water/glycol temperature) indicates that there is a requirement for cooling, the lead compressor of the lead module will energize, provided all safeties of that refrigeration circuit are satisfied.
7. Once there is a system load, the building management system will modulate the system bypass decreasing the bypass flow, as the flow rate through the fan coils increases. This control is provided by the customer external of the chiller but is presumed to be based on the temperature of the water back to the chiller or the pressure differential across the most remote fan coil unit if it has a three-way valve.
8. As the system demand continues to increase, the second compressor within that module will energize, provided all safeties on that circuit are satisfied.
9. As the system demand continues to increase, the leaving water/ glycol mixture temperature from the chiller system will slowly increase until the differential set point is reached (+4°F above set point). When the differential is reached, a second module is brought online. The pump VFD control must be set to ramp up quickly to provide adequate fluid flow to both operating modules and eliminate nuisance alarms such as low flow and low pressure if there is not sufficient flow to the operating modules.
10. As the flow and demand continue to increase, and the temperature once again reaches the set point plus differential.
11. On a decrease in system demand (and flow) such that the leaving water/glycol mixture temperature reaches the set point minus the differential, a compressor will de-energize. Once both operating compressors within an operating module have de-energized, the electronic valve will slowly close off flow to that module. It is critical that the corresponding pump variable frequency drive controller slowly ramps down the speed of the pump to the next operating point so as not to limit flow to the operating chiller modules as the valve time to close is approximately 35 seconds.



Optional Tank and Pump Module

12. This process occurs throughout the operating range of the chiller system
13. If the primary microprocessor fails, the remaining modules will continue to operate in response to demand. Secondary modules in the chiller system,

each have a “distributed primary” microprocessor that allows the system to keep operating if the primary microprocessor fails. The only function the distributed primary cannot perform, is the automatic rotation of modules as described in [Step 2..](#)



Appendix C. Request for Initial Start-up

Thermafit™ AMC Modular Chiller

As part of a continuous commitment to quality, initial start-up of this chiller by a factory-certified technician may be purchased from Trane. No initial start-up will be scheduled without a Request for Initial start-up form completed and on

file with the Trane customer service department. Submitting this form indicates that all critical work described on the form has been completed. To prevent additional charges for aborted start-ups, the following items must be completely functional and operating and this form signed and returned to Trane at least 10 working days prior to the scheduled initial start-up date.

Chiller Initial Start-Up Data

Model Number:	Primary Module Serial Number:
Primary Contact Name:	Primary Contact Phone:
Primary Contact FAX:	Primary Contact Mobile:
Name of Chiller Site:	
Physical Location of Chiller:	
Requested Date for Initial Start-Up: Requested Time for Initial Start-Up:	

Mandatory Initial Start-Up Requirements

Mandatory Tasks	Date Completed	Completed By (Initials)
All chiller modules are installed with minimum clearances available from all sides.		
Refrigeration gauges are indicating equal pressures.		
Chilled water lines from chiller to customer's equipment are permanently connected.		
Chilled water lines have been flushed clean of mud, slag, and other construction debris.		
All chilled water line filters and strainers are clean.		
Chilled water lines have been leak tested according to prestart instructions.		
Chiller reservoir (if included) is at operating level with correct water/glycol mixture.		
High voltage wiring is installed, tested, and functional.		
All water, refrigeration, electrical, and control connections between chiller modules are completed.		
All control wiring between modular chillers is installed, tested, and functional.		
Control wiring is complete, including any remote interface panel or special-purpose module wiring.		
Automatic City Water Switchover (if included) is installed, flushed, and leak-tested.		
Condenser, if applicable, is installed, piped, wired, and leak-tested.		
All responsible installing contractors and sub-contractors are notified to have representatives available on site to provide technical support for the initial start-up procedure.		
Full load will be available for chiller on the initial start-up date.		



Request for Initial Start-up

Initial Start-Up Agreement

By signing this form, you agree the chiller is ready for initial start-up. It is understood that, if the chiller is not ready for initial start-up due to site problems, the initial start-up will be aborted at the discretion of the designated start-up

technician. Payment for an aborted start-up will be forfeited. Rescheduled initial start-ups are subject to any additional costs that may have been incurred by the technician. An approved purchase order or payment in advance will be required to reschedule an aborted initial start-up.

Name (Printed): _____

Date: _____

Signature: _____

Company: _____



Notes

Trane - by Trane Technologies (NYSE: TT), a global innovator - creates comfortable, energy efficient indoor environments for commercial and residential applications. For more information, please visit trane.com or tranetechnologies.com.

Trane has a policy of continuous product and product data improvements and reserves the right to change design and specifications without notice. We are committed to using environmentally conscious print practices.

ARTC-SVX008A-EN 05 Feb 2024
Supersedes (New)

©2024 Trane