



# Installation, Operation and Maintenance Air-Cooled Adaptive Frequency™ Drive with Tracer® AdaptiView™ Control



Model AFDG  
(Remote-Mounted)



Model AFDU  
(Unit-Mounted)

**Models:** AFDG, AFDU

## SAFETY WARNING

Only qualified personnel should install and service the equipment. The installation, starting up, and servicing of heating, ventilating, and air-conditioning equipment can be hazardous and requires specific knowledge and training. Improperly installed, adjusted or altered equipment by an unqualified person could result in death or serious injury. When working on the equipment, observe all precautions in the literature and on the tags, stickers, and labels that are attached to the equipment.



# Introduction

Read this manual thoroughly before operating or servicing this unit.

## Warnings, Cautions, and Notices

Safety advisories appear throughout this manual as required. Your personal safety and the proper operation of this machine depend upon the strict observance of these precautions.

The three types of advisories are defined as follows:

**⚠ WARNING** Indicates a potentially hazardous situation which, if not avoided, could result in death or serious injury.

**⚠ CAUTION** Indicates a potentially hazardous situation which, if not avoided, could result in minor or moderate injury. It could also be used to alert against unsafe practices.

**NOTICE** Indicates a situation that could result in equipment or property-damage only accidents.

## Important Environmental Concerns

Scientific research has shown that certain man-made chemicals can affect the earth's naturally occurring stratospheric ozone layer when released to the atmosphere. In particular, several of the identified chemicals that may affect the ozone layer are refrigerants that contain Chlorine, Fluorine and Carbon (CFCs) and those containing Hydrogen, Chlorine, Fluorine and Carbon (HCFCs). Not all refrigerants containing these compounds have the same potential impact to the environment. Trane advocates the responsible handling of all refrigerants-including industry replacements for CFCs and HCFCs such as saturated or unsaturated HFCs and HCFCs.

## Important Responsible Refrigerant Practices

Trane believes that responsible refrigerant practices are important to the environment, our customers, and the air conditioning industry. All technicians who handle refrigerants must be certified according to local rules. For the USA, the Federal Clean Air Act (Section 608) sets forth the requirements for handling, reclaiming, recovering and recycling of certain refrigerants and the equipment that is used in these service procedures. In addition, some states or municipalities may have additional requirements that must also be adhered to for responsible management of refrigerants. Know the applicable laws and follow them.

### ⚠ WARNING

#### Proper Field Wiring and Grounding Required!

Failure to follow code could result in death or serious injury. All field wiring **MUST** be performed by qualified personnel. Improperly installed and grounded field wiring poses **FIRE** and **ELECTROCUTION** hazards. To avoid these hazards, you **MUST** follow requirements for field wiring installation and grounding as described in **NEC** and your local/state electrical codes.

### ⚠ WARNING

#### Personal Protective Equipment (PPE) Required!

Failure to wear proper PPE for the job being undertaken could result in death or serious injury. Technicians, in order to protect themselves from potential electrical, mechanical, and chemical hazards, **MUST** follow precautions in this manual and on the tags, stickers, and labels, as well as the instructions below:

- Before installing/servicing this unit, technicians **MUST** put on all PPE required for the work being undertaken (Examples; cut resistant gloves/sleeves, butyl gloves, safety glasses, hard hat/bump cap, fall protection, electrical PPE and arc flash clothing). **ALWAYS** refer to appropriate Safety Data Sheets (SDS) and OSHA guidelines for proper PPE.
- When working with or around hazardous chemicals, **ALWAYS** refer to the appropriate SDS and OSHA/GHS (Global Harmonized System of Classification and Labeling of Chemicals) guidelines for information on allowable personal exposure levels, proper respiratory protection and handling instructions.
- If there is a risk of energized electrical contact, arc, or flash, technicians **MUST** put on all PPE in accordance with OSHA, NFPA 70E, or other country-specific requirements for arc flash protection, **PRIOR** to servicing the unit. **NEVER PERFORM ANY SWITCHING, DISCONNECTING, OR VOLTAGE TESTING WITHOUT PROPER ELECTRICAL PPE AND ARC FLASH CLOTHING. ENSURE ELECTRICAL METERS AND EQUIPMENT ARE PROPERLY RATED FOR INTENDED VOLTAGE.**

**⚠ WARNING****Follow EHS Policies!**

Failure to follow instructions below could result in death or serious injury.

- All Trane personnel must follow the company's Environmental, Health and Safety (EHS) policies when performing work such as hot work, electrical, fall protection, lockout/tagout, refrigerant handling, etc. Where local regulations are more stringent than these policies, those regulations supersede these policies.
- Non-Trane personnel should always follow local regulations.

**⚠ WARNING****Refrigerant May Be Under Positive Pressure!**

Failure to recover refrigerant to relieve pressure or the use of non-approved refrigerants, refrigerant substitutes, or refrigerant additives could result in an explosion which could result in death or serious injury or equipment damage. System contains oil and refrigerant and may be under positive pressure.

Recover refrigerant to relieve pressure before opening the system. See unit nameplate for refrigerant type. Do not use non-approved refrigerants, refrigerant substitutes, or refrigerant additives.

## Copyright

This document and the information in it are the property of Trane, and may not be used or reproduced in whole or in part without written permission. Trane reserves the right to revise this publication at any time, and to make changes to its content without obligation to notify any person of such revision or change.

## Trademarks

All trademarks referenced in this document are the trademarks of their respective owners.

## Revision History

Updates to:

- "AFDU Model Number Digit Identification," p. 10, updated the 18th digit. (Digit 18)
- Figure 1, Figure 3, and Figure 9 and Figure 11 added notes about ceramics not having a bearing on common mode chokes.



# Table of Contents

General Information	5	Surge Recovery	28
About This Manual	5	Surge Detection	28
Other Required Manuals	5	UC800 Interface to Adaptive Frequency Drive	29
Cabinet Servicing	5	Service Interface	32
Service Information	5	AFD Operator Interface	32
Parts Ordering Information	5	Tracer AdaptiView Operator Interface	32
Motor Checks	5	Tracer TU Service Tool (Laptop Computer)	32
Controller Checks	6	AFDG/AFDU Startup Procedure	34
AFDG/AFDU Checks	6	Drive Settings	35
Safety Precautions	6	Default Settings	36
Overview	8	Startup Test Log	37
AFDG/AFDU Information	8	Recommended Periodic Maintenance and In- spection	38
Model Number Descriptions	9	Visual Inspection—Power Removed	38
AFDG Model Number Digit Identification	9	Operational Inspection—Power Applied	38
AFDU Model Number Digit Identification	10	Do this every 1–12 months depending on op- erating environment	38
Drive and Cabinet	11	Do as needed	38
Enclosure Rating	11	Chiller Operator Display Content	38
Environmental Conditions	11	Troubleshooting	39
Identifying Trane AFDG/AFDU Cabinet Com- ponents	11	Wiring Schematics	40
About the Cabinet	12		
Lifting the Drive	17		
Input Power and Control Wiring	19		
Installing Input Power Wiring Standard Cab- inet	19		
Torquing Electrical Power Connections	19		
Cabinet Wire Routing	19		
Wire Routing	19		
Wire Sizing	20		
Grounding the Cabinet	20		
UC800 AFD Operation	25		
Adaptive Frequency Drive Control	25		
Introduction	25		
Chiller and AFD Sequence of Operation	25		
Compressor Pressure Coefficient	25		
Surge Boundary	25		
AFD Speed Control	26		
Startup	26		
Re-optimization	27		



# General Information

## About This Manual

This manual is intended for use by experienced service personnel, qualified electrical personnel, Trane service personnel, and Danfoss automation global technical service personnel who are familiar with the features described.

The instructions in this manual outline the procedures for operating the Adaptive Frequency Drive. Operation and maintenance of the controls are also explained in this manual.

## Other Required Manuals

The following publication ships with the Trane Adaptive Frequency Drive from the factory: BAS-SVX21\*-EN (*High power Drive Operating Instructions: TR200*).

## Cabinet Servicing

For information regarding the servicing of drive components please refer to the appropriate Danfoss literature.

## Service Information

This equipment should be installed, adjusted and serviced by qualified electrical maintenance personnel who are familiar with the construction and operation of the equipment and the hazards involved, as defined in the National Electrical Code. Trane assumes no liability for installation or service procedures performed by unqualified personnel.

## Parts Ordering Information

Refer to the model number printed on the Trane Adaptive Frequency Drive nameplate when ordering replacement parts or service for the drive. When ordering parts, contact the local Trane Parts Office in your area. For service, contact a qualified service organization.

### NOTICE

#### Do Not Megohm Test!

Failure to follow instructions below could cause damage to the controller circuitry. Do NOT use a megger to perform continuity checks in the drive equipment.

### ⚠ WARNING

#### Hazardous Voltage w/Capacitors!

Failure to disconnect power and discharge capacitors before servicing could result in death or serious injury. Disconnect all electric power, including remote disconnects and discharge all motor start/run capacitors before servicing. Follow proper lockout/tagout procedures to ensure the power cannot be inadvertently energized. For variable frequency drives or other energy storing components provided by Trane or others, refer to the appropriate manufacturer's literature for allowable waiting periods for discharge of capacitors. Verify with an appropriate voltmeter that all capacitors have discharged. If this equipment is interlocked with other equipment, 115 volts AC may be present in the cabinet even though the main power is disconnected. If this is the case, these interlock signals should be deactivated before any work is performed on this equipment. Suitable warning tags or disconnects should be added to these circuits and all circuits should be tested before attempting to energize or service the controller.

For additional information regarding the safe discharge of capacitors, see PROD-SVB06\*-EN

### ⚠ WARNING

#### Capacitors Must Be Allowed To Discharge!

Failure to disconnect power and discharge capacitors before servicing could result in death or serious injury. Each time power is removed, allow at least 40 minutes for DC units to discharge after power is disconnected before servicing. Use extreme caution when applying power. Equipment terminals and other internal parts of the controller are at line voltage when AC power is connected to the controller. All ungrounded conductors of the AC power line must be disconnected from the controller before it is safe to touch any internal parts of this equipment.

## Motor Checks

1. Check the motor for proper horsepower and voltage ratings. Verify that the chiller rated load amps do not exceed the nameplate rating of the controller.
2. Check that the motor terminals are correctly connected to the controller's power terminals for the proper voltage and motor rotation.

### NOTICE

#### Disconnect Motor Leads!

Failure to disconnect all motor leads prior to megging the motor could cause equipment damage.



## General Information

- Use an ohmmeter to check for any short circuits between the motor frame and the motor power leads. If a short circuit exists, it must be corrected before proceeding.

## Controller Checks

- Check that local, state and national electric codes have been observed for the installation and wiring of this equipment.
- Check that all external power wiring has been properly routed through the cabinet.
- Check all input power and output power connections for tightness.
- Check the chassis ground and other connections for tightness.
- Check all external control connections (this includes the operator station connections) for tightness.
- Check to assure incoming power to the drive is phased A, B, C.

## AFDG/AFDU Checks

### NOTICE

#### Perform Visual Inspection!

Before powering up this drive for the first time conduct a visual inspection for the following:

- Shipping damage.
- Signs of moisture.
- Signs of debris or dust from storage.
- Signs of corrosion on components and/or enclosure.

These conditions could cause equipment damage. Do not power up equipment if you have concerns regarding equipment condition. Upon initial power up, remain in the area for the first two hours of operation and observe the chiller and drive for any abnormalities. Contact CenTraVac™ Technical Support for assistance if needed.

### ⚠ WARNING

#### Hazardous Voltage!

Failure to ensure that all enclosure doors are closed and properly secured with fasteners when operating equipment could result in death or serious injury.

## Safety Precautions

- This equipment should be adjusted and serviced by qualified electrical maintenance personnel familiar with the construction and operation of the equipment and the hazards involved.

- Be sure the input disconnect is in the correct position, either "on" or "off" depending on the work to be performed.
- Check the status of the drive shutdown interlocks, if used. These interlocks can be limit switches, guards or safety switches installed around the driven machine or the system interface controller.

### ⚠ WARNING

#### Bypassed Electrical Interlocks!

Failure to return all interlocks to operation when the startup is completed could result in death, serious injury or equipment damage. The electrical interlocks provide machine and personal protection. If deactivated or bypassed for servicing, use extreme caution when performing the startup.

- Check to see that the AFDG/AFDU is properly ground to earth. See "Grounding the Cabinet," p. 20 in "Input Power and Control Wiring," p. 19.

### ⚠ WARNING

#### Proper Field Wiring and Grounding Required!

Failure to follow code could result in death or serious injury. All field wiring MUST be performed by qualified personnel. Improperly installed and grounded field wiring poses FIRE and ELECTROCUTION hazards. To avoid these hazards, you MUST follow requirements for field wiring installation and grounding as described in NEC and your local/state electrical codes.

### ⚠ WARNING

#### Hazardous Voltage!

Failure to follow instructions below could result in death, serious injury or equipment damage. Do NOT remove or insert control boards or fuses while input power is connected to the controller.

**⚠ WARNING****Hazardous Service Procedures!**

Failure to follow all precautions in this manual and on the tags, stickers, and labels could result in death or serious injury.

Technicians, in order to protect themselves from potential electrical, mechanical, and chemical hazards, **MUST** follow precautions in this manual and on the tags, stickers, and labels, as well as the following instructions: Unless specified otherwise, disconnect all electrical power including remote disconnect and discharge all energy storing devices such as capacitors before servicing. Follow proper lockout/tagout procedures to ensure the power can not be inadvertently energized. When necessary to work with live electrical components, have a qualified licensed electrician or other individual who has been trained in handling live electrical components perform these tasks.

**⚠ WARNING****Hazardous Voltage w/Capacitors!**

Failure to disconnect power and discharge capacitors before servicing could result in death or serious injury. Disconnect all electric power, including remote disconnects and discharge all motor start/run capacitors before servicing. Follow proper lockout/tagout procedures to ensure the power cannot be inadvertently energized. For variable frequency drives or other energy storing components provided by Trane or others, refer to the appropriate manufacturer's literature for allowable waiting periods for discharge of capacitors. Verify with an appropriate voltmeter that all capacitors have discharged.

- Before working on the controller, check to be sure capacitors are discharged with a DC voltmeter on the 1000V scale. Charged capacitors require at least 40 minutes to discharge to less than 50Vdc after line power is removed.
- Before proceeding with the startup procedure, disconnect and lockout all incoming power to the drive controller!

*For additional information regarding the safe discharge of capacitors, see PROD-SVB06\*-EN*



# Overview

## AFDG/AFDU Information

The AFDG/AFDU air-cooled Adaptive Frequency Drive is a pulse width modulated (PWM) design. It is designed for 460/480/575 volt application. This drive converts AC power to DC power and back to AC power. The incoming 460/480/575 volts are converted to a constant 650 Vdc by a rectifier bridge (SCRs and diodes), and into a section of capacitors that are used to store the DC voltage. The DC output feeds the inverter IGBTs that switch at predetermined time to change the DC input voltage to a symmetrical AC output voltage of desired magnitude and frequency. The output frequency range is 38 to 60 hertz.

The DC voltage is fixed at 700 Vdc. A variable output is accomplished by PWM control within the inverter by the IGBTs which are basically transistors that turn on and off in response to the gate driver.

A combination of two distinct operating modes make up the AFDG/AFDU control within the chiller's UC800 control. First by controlling the inlet vanes, and second by modulating impeller speed from 38 to 60 hertz. The IGBTs control the speed in response to the UC800 compressor control signal. Circuit breakers, surge capacitors and ground faults are standard on all AFDG/AFDU units.

Some of the basic principles of the drive are:

- Minimum efficiency of 97 percent at rated load and 60 Hz.
- Unit displacement power factor of 0.96 at all loads.
- Low starting current.
- The current never exceeds the rated load amps.
- The AFDG/AFDU varies the motor speed in response to the speed command from the UC800 control.

The CenTraVac™ Control Panel has full control of the unit operation, including the start/stop functions. If you encounter a fault condition or an alarm on the drive, the Tracer® AdaptiView™ display will indicate "alarm" and an "alarm message."





# Model Number Descriptions

## AFDG Model Number Digit Identification

Model number digits are selected and assigned in accordance with the following definitions using the above model number example:

### Digit 1, 2, 3 – Unit Function

AFD= Adaptive Frequency Drive

### Digit 4 – Development Sequence

G = Remote-Mounted, Non-Communicating with Tracer® AdaptiView™ Controls

### Digit 5, 6, 7, 8 – Starter Size

Use Rated Load Amps (RLA) Value

### Digit 9 – Unit Voltage

F = 460V-60Hz-3Ph  
G = 480V-60Hz-3Ph  
H = 575V-60Hz-3Ph  
J = 600V-60Hz-3Ph  
S = Special

### Digit 10, 11 – Design Sequence

AB = Chokes required on R123 CVT chillers and Not R514! Chillers  
A0 = Original Design of CH531 Chiller Control  
B0 = Tracer® AdaptiView™ Controls with FC102 Drive  
C0 = Tracer® AdaptiView™ Controls with TR200 Drive  
D0 = Tracer® AdaptiView™ Controls with TR200 Drive and Common Mode Cores  
E0 = Secondary CT Requirement on SSRLs of 730, 780, 850, 890, 945, and 1050  
F0 = Drive Bus Bars on SSRLs of 730, 780, 850, 890, 945, and 1050  
G0 = D-Drive Module on SSRLs of 190, 240, 302, 361, and 443 at 460V; and 155, 192, 242, 290, 344, and 400 at 575V  
H0 = D Drive Module SSRL 536 at 460V

### Digit 12 – Starter Type

B = Remote-Mounted

### Digit 13 – Agency Listing

0 = UL and CUL Listed (Standard on All Units)

### Digit 14 – Special Options

0 = None  
1 = Nema 12  
S = Special Options (See Sales Order)

### Digit 15 – VFD Frame Size (SSRL)

A = 155  
B = 192  
C = 242

D = 290  
E = 344  
F = 400  
G = 450  
H = 500  
J = 570  
K = 630  
L = 730  
M = 850  
N = 945  
P = 1060  
R = 1260  
T = 190  
U = 240  
V = 302  
W = 361  
X = 443  
Y = 540  
Z = 590  
1 = 678  
2 = 780  
3 = 890  
4 = 1050  
5 = 1160  
6 = 1380  
7 = 1530  
8 = 1415  
9 = 536

### Digit 16 – Connection Type

2 = Standard Circuit Breaker  
4 = High Interrupting Breaker  
8 = Fused Disconnect Switch  
S = Special

### Digit 17 – Control Power Option

B = Control Power Transformer 4kVA

### Digit 18 – Power and Ground Wire Length (Measured from the back of the panel to the compressor housing)

A = 23 inches  
S = Special Length

### Digit 19 – Common Mode Cores

0 = No Common Mode Cores  
C = Common Mode Cores



## Model Number Descriptions

---

### AFDU Model Number Digit Identification

Model number digits are selected and assigned in accordance with the following definitions using the above model number example:

#### Digit 1, 2, 3 – Unit Function

AFD= Adaptive Frequency Drive

#### Digit 4 – Development Sequence

U = Unit Mounted, Air-Cooled, Non-Communicating with Tracer® AdaptiView™ Controls

#### Digit 5, 6, 7, 8 – Starter Size

Use Rated Load Amps (RLA) value

#### Digit 9 – Unit Voltage

F = 460V-60Hz-3Ph  
G = 480V-60Hz-3Ph  
H = 575V-60Hz-3Ph  
J = 600V-60Hz-3Ph  
S = Special

#### Digit 10, 11 – Design Sequence

AA = Original Design of Tracer® AdaptiView™ Chiller Control with TR200 Drive

#### Digit 12 – Starter Type

A = Unit-Mounted

#### Digit 13 – Agency Listing

0 = UL and CUL Listed (Standard on All Units)

#### Digit 14 – Special Options

0 = None  
S = Special Options (See Sales Order)

#### Digit 15 – VFD Frame Size (SSRL)

C = 154  
D = 191  
E = 239  
F = 241  
G = 289  
H = 299  
J = 343  
K = 358  
L = 441  
M = 534

#### Digit 16 – Connection Type Short Circuit Rating (SCCR)

2 = Standard Circuit Breaker  
4 = High Interrupting Breaker  
S = Special

#### Digit 17 – Control Power Option

B = Control Power Transformer 4kVA

#### Digit 18 – Power and Ground Wire Length<sup>1</sup>

A = 23 Inches  
S = Special Length

#### Digit 19 – Common Mode Cores

0 = No Common Mode Cores  
C = Common Mode Cores

---

<sup>1</sup> Power and Ground Wire Length is measured from the back of the panel to the compressor housing.



# Drive and Cabinet

## Enclosure Rating

The Trane® cabinet has a NEMA 1 enclosure rating:  
NEMA 1: Vented. Intended for general-purpose indoor applications.

## Environmental Conditions

**Important:** *Location of the AFDG/AFDU is important if proper performance and normal operating life is to be expected. Therefore, unless designed for special environments, the controller should be installed in an area where the following conditions exist*

- Verify that NEMA 1 enclosure drives can be kept clean and dry.
- The area chosen should allow the space required for proper air flow. An 8 inch (20.32 cm) minimum clearance is required above the cabinet.
- Be sure that the NEMA 1 enclosure is installed away from oil, coolants, or other airborne contaminants.
- Do not install the drive above 3300 feet (1000 meters) without derating output power. For every 3300 feet (1000 meters) above 3300 feet (1000 meters), derate the output current 4%.
- Line frequency is 60 Hz.
- Line Voltage is 460/480/575 volts; variation are within  $\pm 10\%$ .
- Non-corrosive location.
- Verify that the drive location will meet the environmental conditions specified in Table 1.

**Table 1. Environmental conditions**

Condition	Specification
Ambient Temperature (outside NEMA 1 enclosure)	14°F to 104°F (-10°C to + 40°C)
Storage Temperature (Ambient)	-13°F to 149°F (-25°C to 65°C)
Humidity	5% to 95% (non-condensing)

## Identifying Trane AFDG/AFDU Cabinet Components

Trane AFDG/AFDU cabinets have the following main components. For convenience, the drive is discussed in two sections, a rectifier (input) and inverter (output) sections.



# Drive and Cabinet

## About the Cabinet

This section provides cabinet dimension information and shows where the wire entry areas are located.

Figure 1. AFDG (remote-mounted) cabinet dimensions: Frame D3 and D4, in.

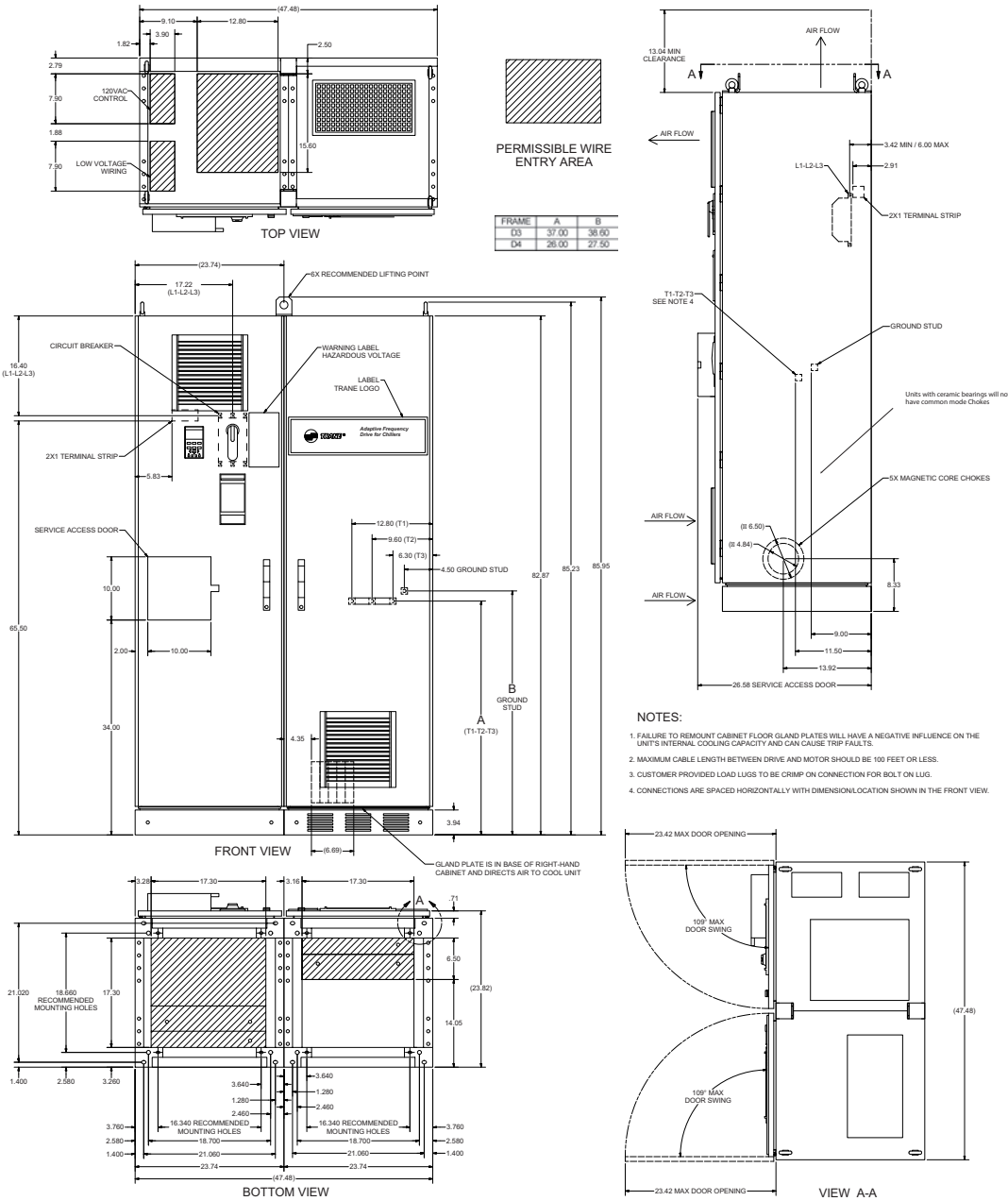

**Important:** If wiring to the right-most cabinet, refer to Danfoss manual BAS-SVX21\*-EN (High power Drive Operating Instructions: TR200) for special sealing instructions. The gland plate must be fitted to the frequency converter to ensure the specified protection degree, as well as ensuring proper cooling of the unit. If the gland plate is not mounted,

the frequency converter may trip on Alarm 69, Pwr. Card Temp.

Figure 2. AFDG (remote-mounted) cabinet dimensions: Frame E1 and E2, in.

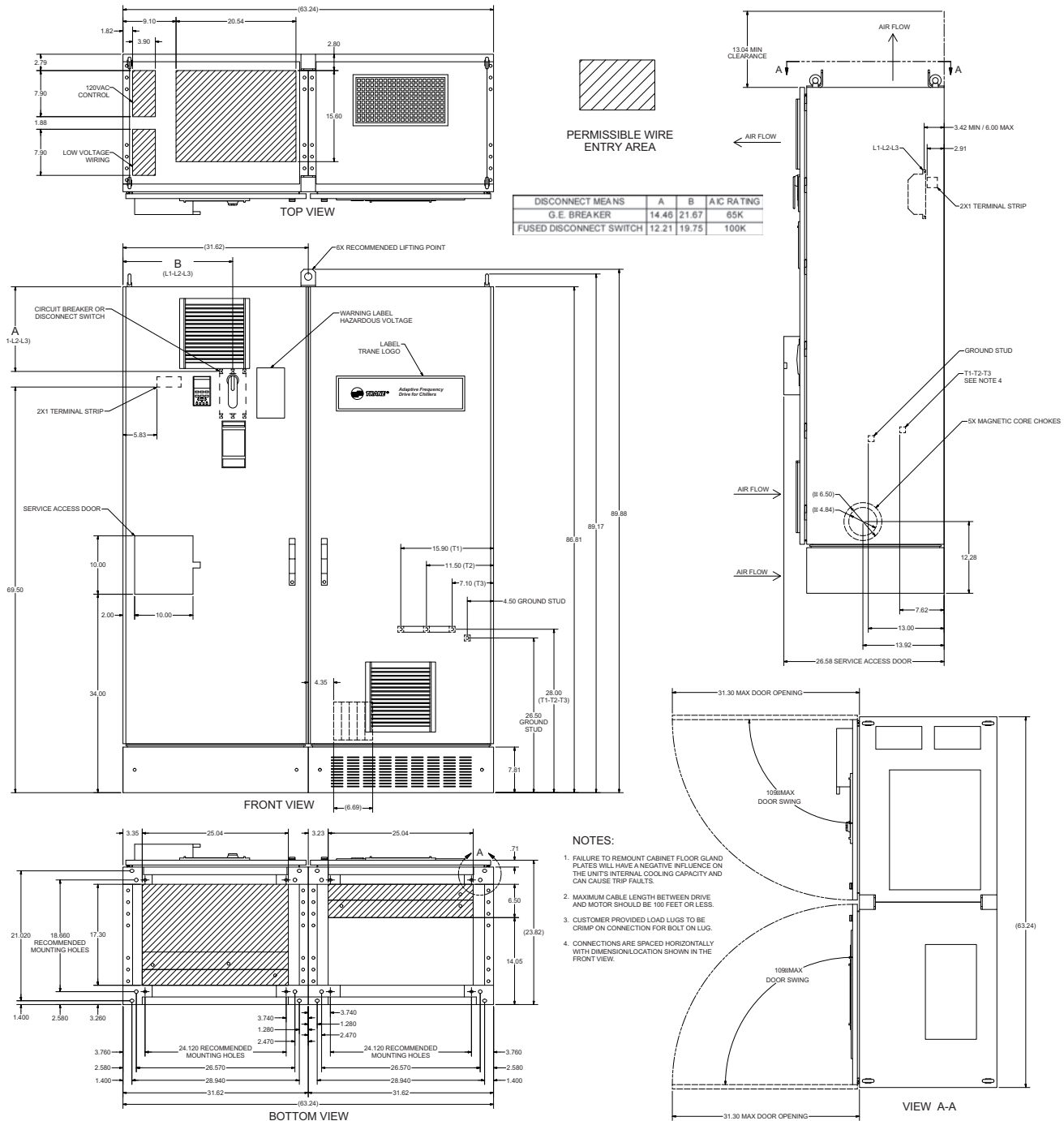

**Important:** If wiring to the right-most cabinet, refer to Danfoss manual BAS-SVX21\*-EN (High power Drive Operating Instructions: TR200) for special sealing instructions. The gland plate must be fitted to the frequency converter to ensure the specified protection degree, as well as ensuring proper cooling of the unit. If the gland plate is not mounted,

the frequency converter may trip on Alarm 69, Pwr. Card Temp.

Figure 3. AFDG (remote-mounted) cabinet dimensions: Frame F3, in.

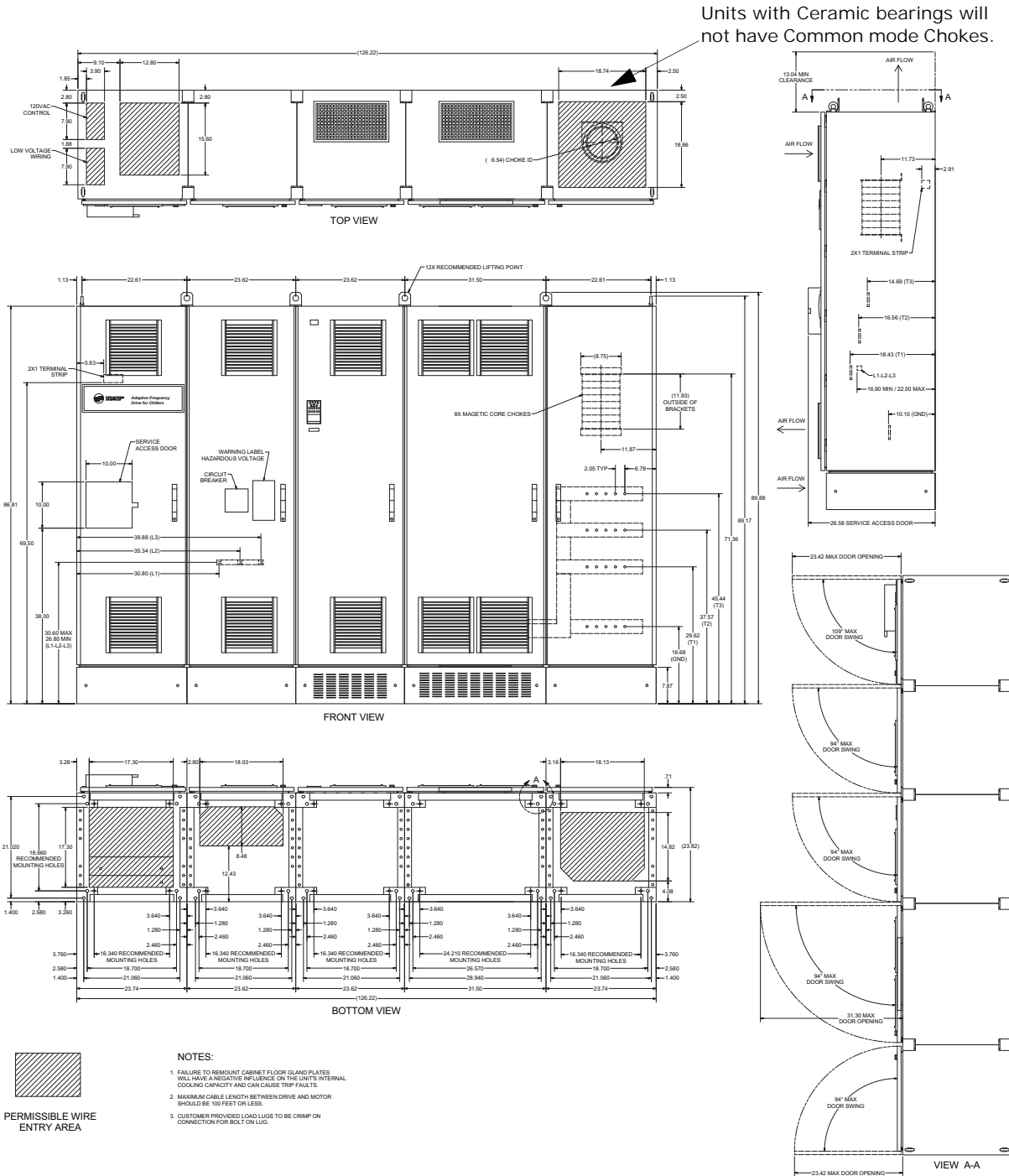

**Important:** If wiring to the right-most cabinet, refer to Danfoss manual BAS-SVX21\*-EN (High power Drive Operating Instructions: TR200) for special sealing instructions. The gland plate must be fitted to the frequency converter to ensure the specified protection degree, as well as ensuring proper cooling of the unit. If the gland plate is not mounted,

the frequency converter may trip on Alarm 69, Pwr. Card Temp.

Figure 4. AFDG (remote-mounted) cabinet dimensions: Frame F4, in.

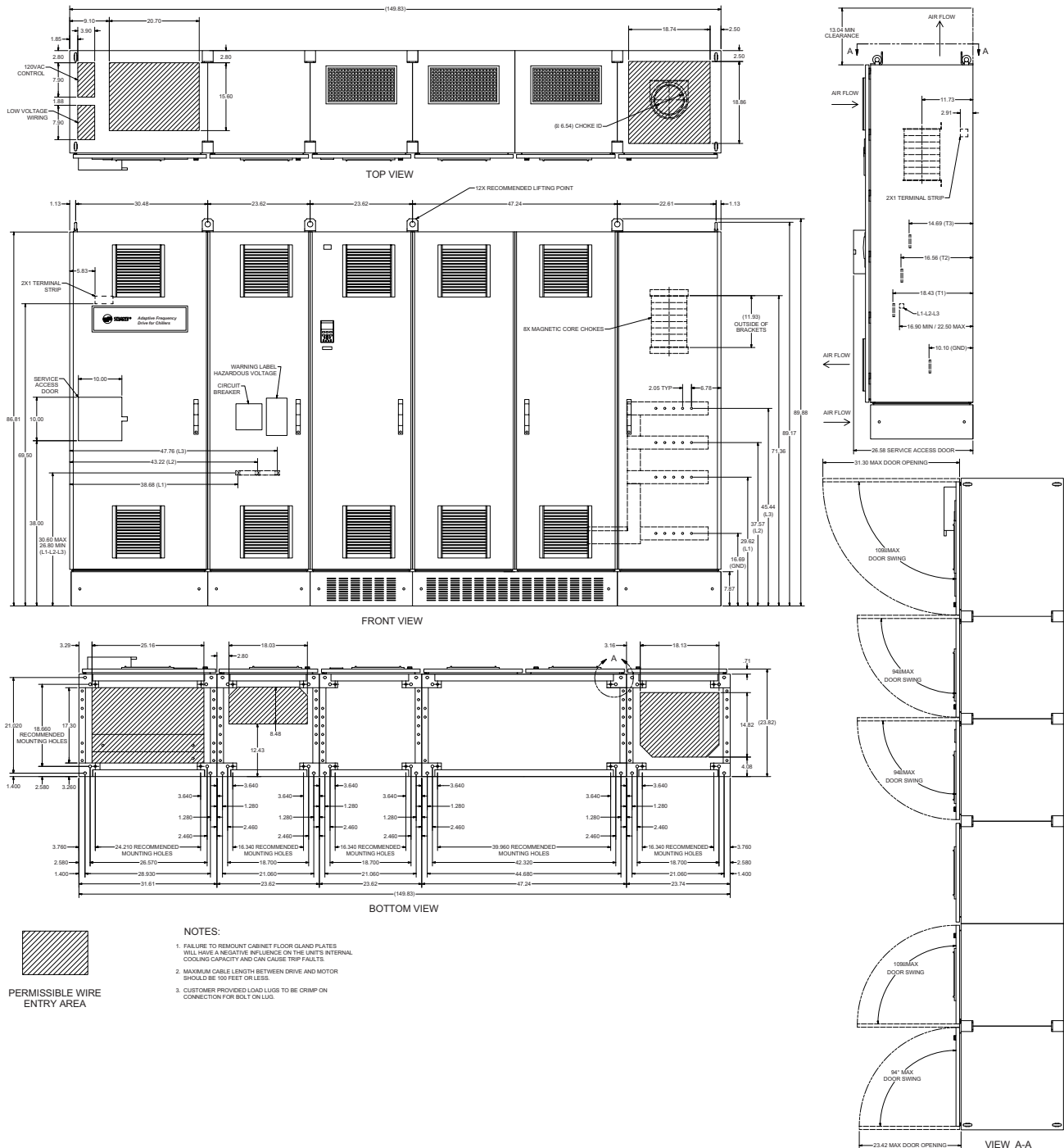

**Important:** If wiring to the right-most cabinet, refer to Danfoss manual BAS-SVX21\*-EN (High power Drive Operating Instructions: TR200) for special sealing instructions. The gland plate must be fitted to the frequency converter to ensure the specified protection degree, as well as ensuring proper cooling of the unit. If the gland plate is not mounted,

the frequency converter may trip on Alarm 69, Pwr. Card Temp.

**Figure 5. AFDU (unit-mounted) cabinet dimensions, in.**

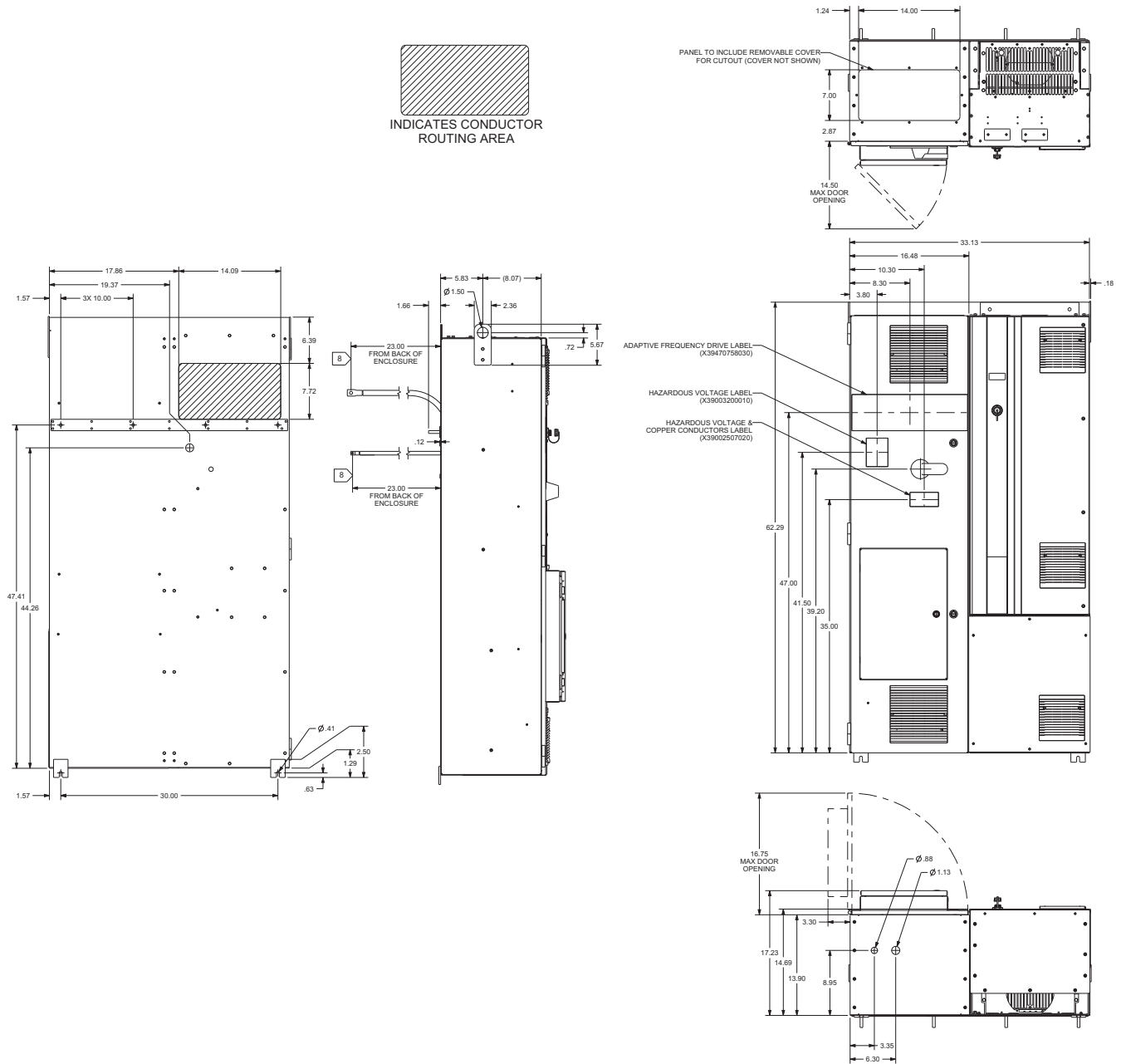

**Notes:**

- Allow 35 in. for door swing clearance.
- Ground cable to be 4/0 AWG with lug for 3/8-in. bolt.
- Ratings are X1000 amps interrupting capacity (KAIC).
- Breaker AIC (Amps Interrupting Capacity) = Applies to circuit breaker as a component only and is the maximum current that a circuit can interrupt without damage to itself.
- Starter SCR (Short Circuit Rating) = The maximum fault current to which a starter may be exposed and safely

be contained within the starter enclosure. However, the components may sustain damage.



## Lifting the Drive

### ⚠ WARNING

#### Heavy Objects!

Failure to properly lift unit could result in death or serious injury. Do not use cables (chains or slings) except as shown. Each of the cables (chains or slings) used to lift the unit must be capable of supporting the entire weight of the unit. Lifting cables (chains or slings) may not be of the same length. Adjust as necessary for even unit lift. Other lifting arrangements may cause equipment or property-only damage.

### ⚠ WARNING

#### Improper Unit Lift!

Failure to properly lift unit could result in death or serious injury or possible equipment or property-only damage. Test lift unit approximately 24 inches (61 cm) to verify proper center of gravity lift point. To avoid dropping of unit, reposition lifting point if unit is not level.

**Important:** AFDG (remote-mounted) and AFDU (unit-mounted) have differing lift point locations and lifting procedures. For AFDG, refer to Figure 6, p. 17 and Table 2, p. 17; for AFDU, refer to Figure 7, p. 18, associated text, and Table 3, p. 18.

**Figure 6. Lift point locations for AFDG (remote-mounted)**

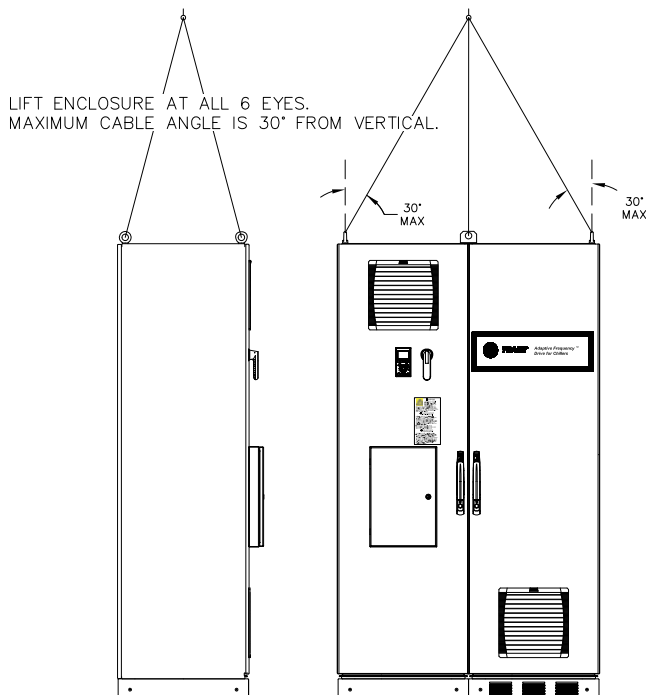

**Table 2. Drive weights for AFDG (remote-mounted)**

Voltage	Drive Panel SRRL Amp Rating	Frame	Weight (lb)
460/480	169	D3	989
	213		1019
	268	D4	1121
	321		1144
	394		1187
	480	E2	1504
	524		1533
	603		1531
	649		1634
	693	F3	2885
	791		2885
	933		2885
	1031		2885
	1227	F4	3419
1360	3419		
575/600	138	D3	989
	171		1019
	215	D4	1121
	258		1145
	306		1187
	356	E2	1217
	400		1504
	444		1539
	507		1595
	560	F3	1681
	649		2885
	756		2885
	840		2885
	942	F4	3419
1120	3419		

**Figure 7. Lift point locations for AFDU (unit-mounted)**

- Two lift points are provided at the top of the AFDU (see [Figure 7](#)).
- Use appropriately rated rigging equipment to ensure a vertical lift from each lift eye.
- Use of two chain hoists (one for each lift eye), or use of a single hoist with a spreader bar are permissible methods for lifting the drive.

**Table 3. Drive weights for AFDU (unit-mounted)**

Voltage	Drive Panel SRRL Amp Rating	SCCR	Panel Weight (lb)
460/480	239	65K	527
	299		527
	358		666
	441		666
	534		679
	239	100K	527
	299		527
	358		666
	441		666
	534		679
575/600	154	65K	524
	191		524
	241		663
	289		666
	343		666
	154	100K	524
	191		524
	241		663
	289		666
	343		666



# Input Power and Control Wiring

## Installing Input Power Wiring Standard Cabinet

Use the following steps to connect AC input power to the cabinet:

### ⚠ WARNING

#### Hazardous Voltage w/Capacitors!

Failure to disconnect power and discharge capacitors before servicing could result in death or serious injury. Disconnect all electric power, including remote disconnects and discharge all motor start/run capacitors before servicing. Follow proper lockout/tagout procedures to ensure the power cannot be inadvertently energized. For variable frequency drives or other energy storing components provided by Trane or others, refer to the appropriate manufacturer's literature for allowable waiting periods for discharge of capacitors. Verify with an appropriate voltmeter that all capacitors have discharged.

For additional information regarding the safe discharge of capacitors, see PROD-SVB06\*-EN

### NOTICE

#### Load Side Wiring!

Failure to route the wires through the cores could result in bearing damage. The electrical wiring from the drive output to the motor must be routed through the magnetic cores. The cores are used to protect the motor bearings.

1. Turn off, lock out, and tag the input power to the drive.
2. Load wires from the drive to the motor must be routed through the common mode choke.

### NOTICE

#### Equipment Failure!

Failure to follow instructions below could result in damaged equipment. Do not cut holes in adaptive frequency drive enclosure. Debris falling inside of adaptive frequency drive could cause failure of electronic components.

3. Once removed, drill the wire routing holes in the panel. These wire routing holes are the only entry points for input power wiring into the cabinet.
4. Install the appropriate conduit hubs.
5. Reinstall the cabinet's panel.
6. Connect the three-phase input power leads to circuit breaker terminals L1, L2, and L3.
7. Tighten connections to 30 ft-lb (40.7 N·m). Use only copper conductors for the input power leads.

Input power wiring should be copper and should be sized according to applicable codes to handle the drive's continuous rated input current.

Refer to submittals for power lug sizes and location along with control wiring specifics for the controller.

**Important:** Power connections should be re-torqued after the first three to six months of operation and on an annual basis thereafter.

## Torquing Electrical Power Connections

Use a torque wrench to tighten power connections. A torque wrench eliminates the human element and provides proper hardware tightening.

Proper torque for connections depends on both the bolting materials and the metals being connected. Strand migration will occur when the copper is under prolonged pressure.

Electrical power terminations should be rechecked for tightness when the apparatus is first installed and periodically afterwards. The conductor could flow under prolonged pressure. Thermal cycling will be greater during the first few months in operation.

Most hardware used for making a bolted electrical joint will be low carbon steel. The hardware does not carry electrical current but holds the two conducting surfaces together under pressure. When properly torqued, the slight elongation of the bolt or screw acts to maintain pressure on the electrical joint. The thermal expansion of steel is less than that of the conducting metals, which is usually copper.

The pressure at the electrical joint will vary slightly during thermal cycling and reduces somewhat when there is cold flow in the conducting metals. Re-torquing will re-establish the surface pressure, which is essential to keeping a low resistance drop between the two conducting surfaces and avoiding eventual failure.

## Cabinet Wire Routing

All wiring should be installed in conformance with the applicable local, national, and international codes (for example, NEC/CEC). Control wiring enters the cabinet through the left side and terminates at the control panel's terminal block. Tighten the control wire connections to 7.1 to 8.9 in-lb (0.8 to 1.0 N·m).

## Wire Routing

**Note:** Wiring from the drive to the motor is required to be routed through the magnetic cores (as illustrated in Figure 8, p. 21).



## Input Power and Control Wiring

### Wire Sizing

Care should be taken to see that all interconnection wiring and ground wiring is sized and installed in conformance with the National Electrical Code (NEC), the National Fire Protection Association (NFPA), or the Canadian Electrical Code (CEC) as applicable, and other appropriate local codes. Refer to controller and motor nameplates for electrical data.

#### **⚠ WARNING**

#### **Hazardous Voltage/Improper Grounding!**

**Hazardous voltage due to improperly grounded electrical components could result in death or serious injury. The motor controller has a chassis ground that must be connected to an earth ground.**

### Grounding the Cabinet

**Note:** Follow Applicable Codes! The user is responsible for conforming to all applicable, local, national, and international codes. Failure to observe this precaution could result in damage to, or destruction of, the equipment.

Use the following steps to ground the AFDG (remote-mounted) cabinet:

1. Open the left-hand enclosure door of the drive. The grounding stud is located just above and to the left of the breaker.
2. Run a suitable earth ground (completed by field) to the cabinet's ground connection point. The grounding lug is capable of accepting up to 4/0 AWG wire. Tighten the ground connections to 375 in·lb (42.4 N·m).

**Note:** The AFDU (unit-mounted) ships grounded to the chiller.

#### **⚠ WARNING**

#### **Proper Field Wiring and Grounding Required!**

**Failure to follow code could result in death or serious injury. All field wiring MUST be performed by qualified personnel. Improperly installed and grounded field wiring poses FIRE and ELECTROCUTION hazards. To avoid these hazards, you MUST follow requirements for field wiring installation and grounding as described in NEC and your local/state electrical codes.**

#### **NOTICE**

#### **Equipment Damage!**

**Failure to follow instructions below could result in damage to equipment. Do not route signal and control wiring with power wiring in the same conduit. This can interfere with drive operation.**

**Table 4. AFDG (remote-mounted) component list (see Figure 8, p. 21 for drive component layout)**

2A1	Starter module, located on the front door, behind the small panel
2A2	Adaptive frequency drive
2A3	Starter power supply
2A10	Starter drive fault input, located on the front door, behind the small panel
2A11	Speed signal output, located on the front door, behind the small panel
2F1,2,3	Control power primary fusing
2F4	Control power secondary fusing
2F22	Adaptive frequency drive supplemental fusing
2K1	Start contactor
2K2	Run contactor
2K11	Oil pump interlock relay
2Q1	Line potential main circuit breaker
2T1,2,3	Line current transformer
2T5	Control power transformer
2X1,2	Starter panel terminal blocks

Figure 8. AFDG (remote-mounted) component layout (see Table 4, p. 20 for drive component list)

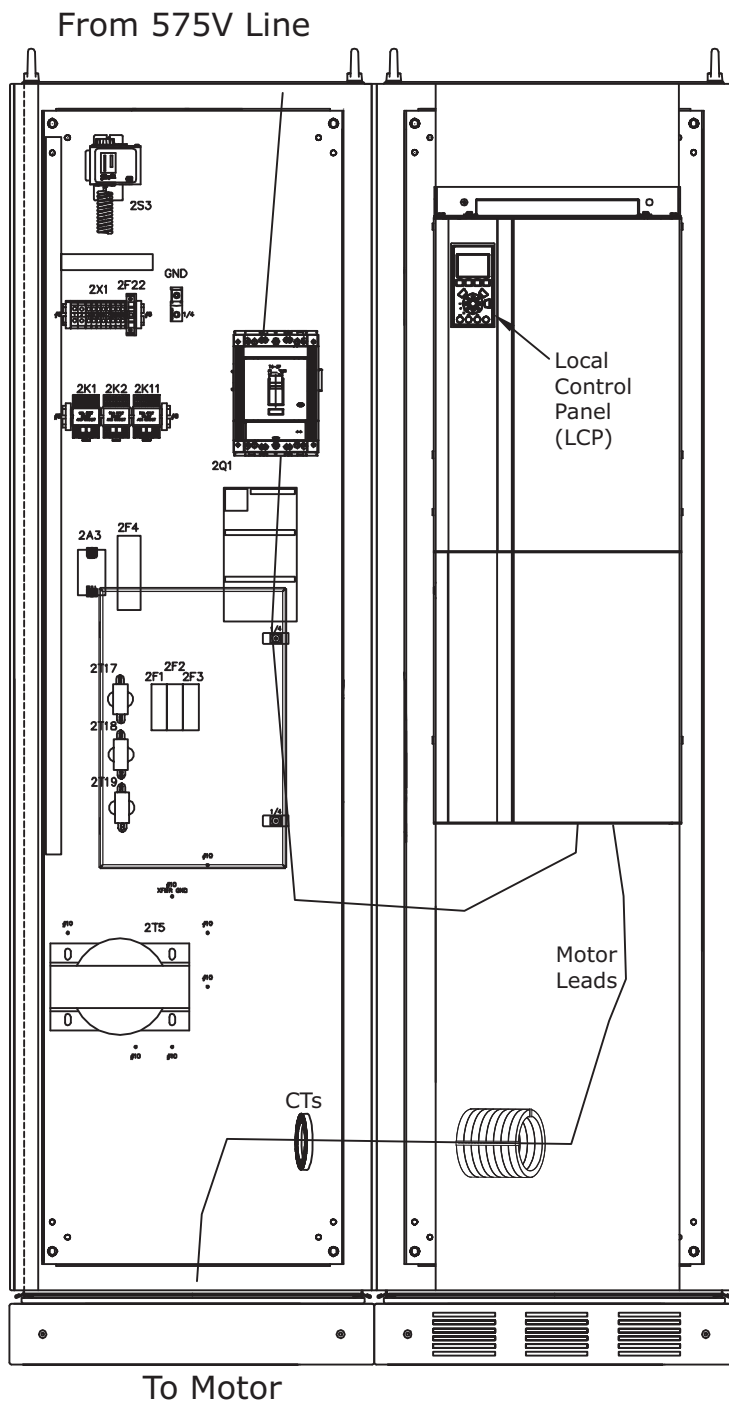

**Note:** Wiring from the drive to the motor is required to be routed through the magnetic cores (as illustrated in Figure 8).

## Input Power and Control Wiring

---

Figure 9. AFDG (remote-mounted) common mode choke

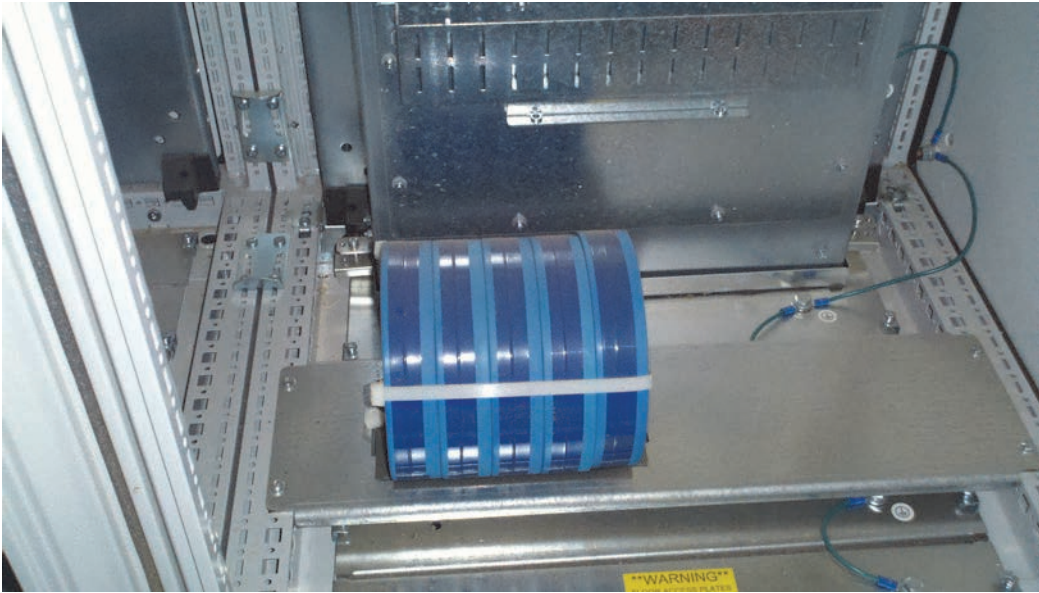

Units with Ceramic bearings will not have common mode chokes

Figure 10. AFDG (remote-mounted) open assembly (no doors): F4 Units (F3 Units are similar, but have only two inverters)

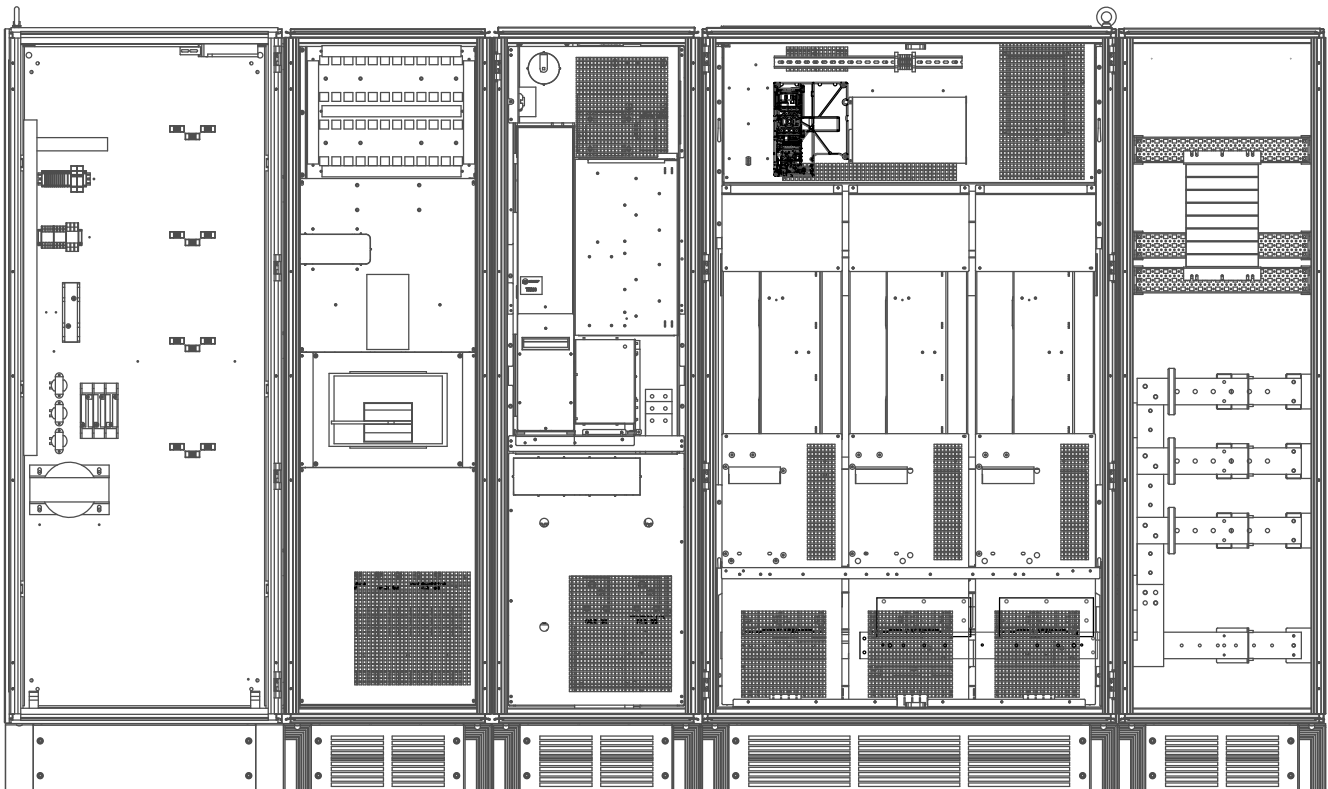
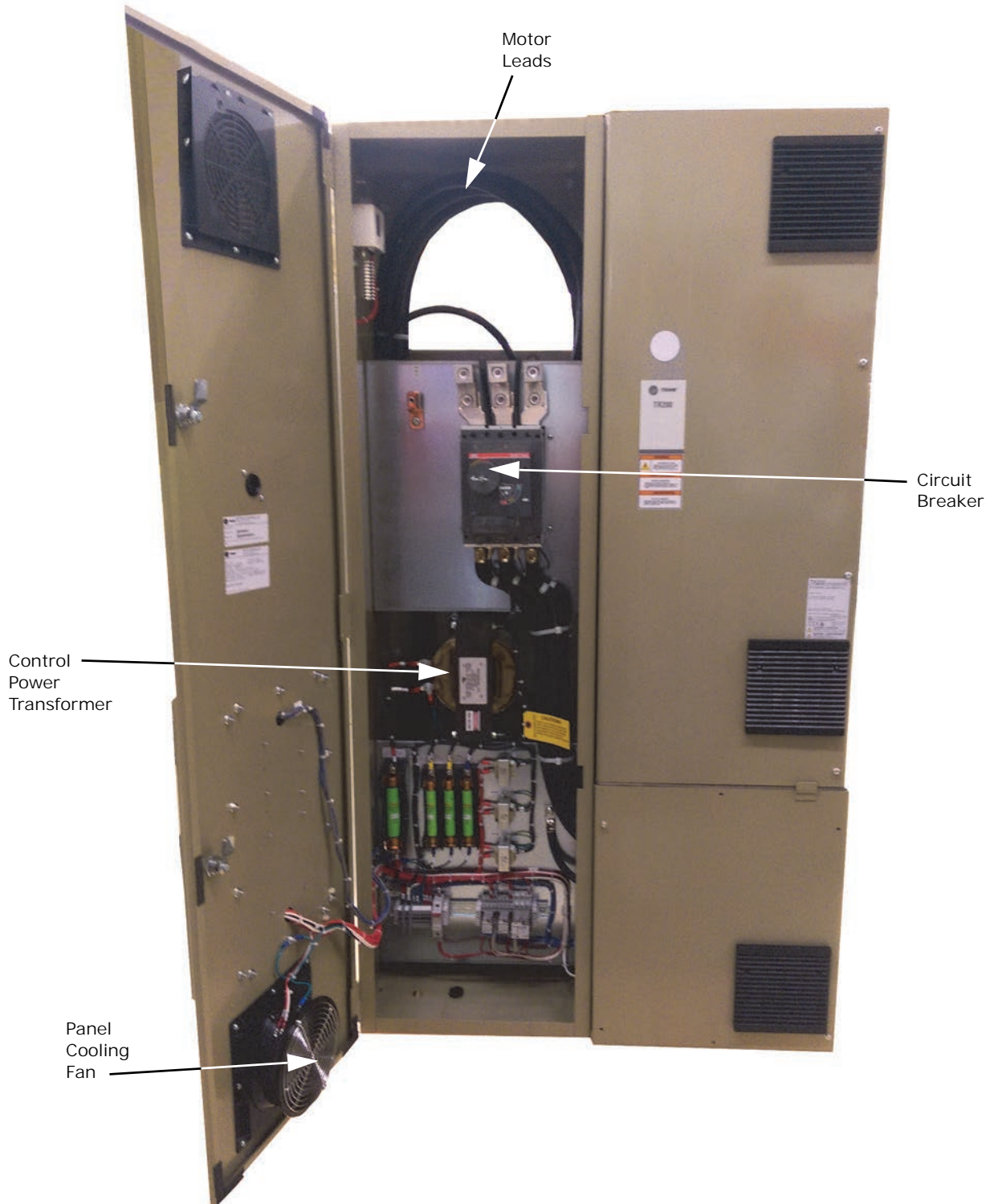
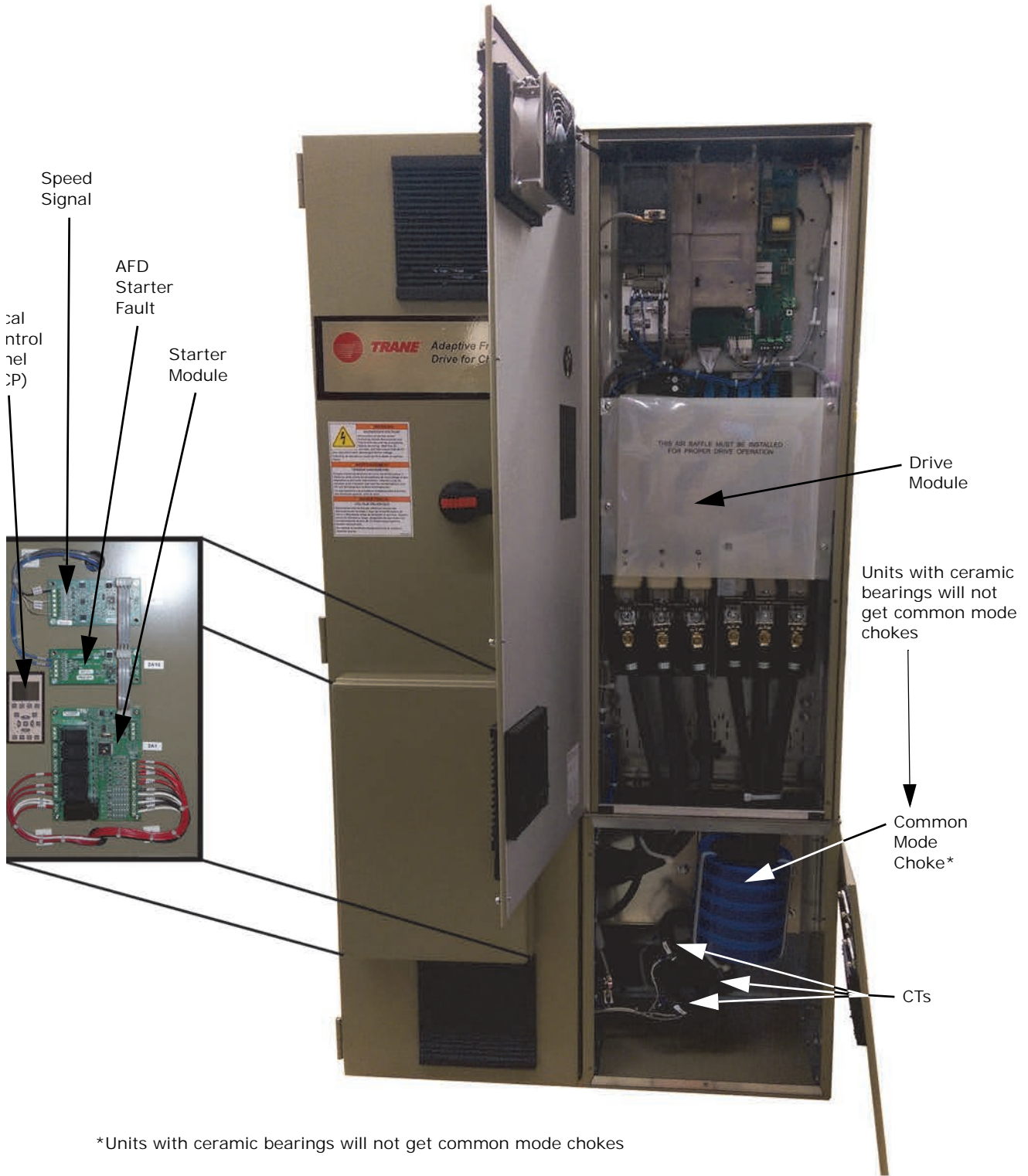

Figure 11. AFDU (unit-mounted) component layout



# Input Power and Control Wiring

Figure 11. AFDU (unit-mounted) component layout (continued)







# UC800 AFD Operation

## Adaptive Frequency Drive Control

### Introduction

#### Achieving Efficiency

Adjustable speed impeller control is used to improve CenTraVac™ efficiency at part-load while tower relief is available. This occurs because the addition of the variable frequency drive gives the chiller control an extra degree of control freedom. The combination of inlet guide vane position and variable speed creates the possibility to control both chiller capacity and compressor efficiency. By manipulating speed and inlet guide vane position it is possible to adjust the aerodynamic loading on the compressor to operate in a region of higher efficiency.

#### Challenges

There are challenges associated with achieving high efficiency. The region of higher efficiency is near the compressor surge boundary. Surge occurs when the compressor can no longer support the differential pressure required between the evaporator and condenser. Reducing compressor speed can improve efficiency; however, at some point the reduced impeller speed does not add enough dynamic pressure to the discharged refrigerant. When the total pressure (static + dynamic) leaving the compressor is less than the condenser pressure, refrigerant will start to flow backwards from the condenser. The flow reversal from the condenser to the compressor discharge creates a sudden loss of the dynamic pressure contribution from the compressor. Refrigerant flows backwards through the compressor creating an unpleasant audible noise. Surge is avoided when possible because it causes a loss of efficiency and cooling capacity if the compressor is allowed to cycle in and out of surge for an extended period.

#### Solutions

The adjustable speed control algorithm of the Tracer® UC800 control was developed to operate near the surge boundary by periodically testing to find the surge boundary and then holding conditions at an optimal distance from surge. Once the optimal operating condition is found the algorithm can avoid the surge in the future. When surge is detected, a surge recovery routine makes adjustments to move out of surge, reestablish stable operating conditions, and adjust the control boundary to avoid surge in the future.

#### Chiller and AFD Sequence of Operation

In the UC800, the chiller/AFD sequence of operation is identical to a standard fixed speed chiller. Chiller capacity control, safeties, and limits work in the same manner regardless of whether an AFD is present.

The UC800's AFD speed control algorithm will simultaneously set Inlet Guide Vane (IGV) position and

compressor speed to achieve a desired compressor loading command while holding a fixed margin of safety between the compressor operating point and compressor surge. In order to quantify nearness to surge, a non-dimensional parameter called "compressor pressure coefficient" is used as a measure of surge potential. Decreasing motor speed increases the compressor pressure coefficient. The goal of the AFD control algorithm is to reduce speed enough to increase the pressure coefficient to the surge boundary.

#### Compressor Pressure Coefficient

The non-dimensional pressure coefficient is derived based on turbo machinery principles. Fundamentally, the pressure coefficient is the ratio between the potential energy based on the pressure rise across the compressor and the kinetic energy of the refrigerant at the compressor discharge. This normalized equation uses enthalpy change across the compressor as a measure of potential energy and compressor parameters such as average impeller diameter, speed, and number of stages, to determine kinetic energy.

The kinetic energy can be reduced by reducing the condenser pressure. To achieve condenser pressure reduction, reduce the temperature of the entering tower water. To obtain the best efficiency, follow a tower relief schedule at part loads.

#### Surge Boundary

Surge boundary is a non-linear, empirically derived function of the compressor load. For the UC800, the compressor pressure coefficient boundary is defined as a function of IGV position as shown on [Figure 12](#).

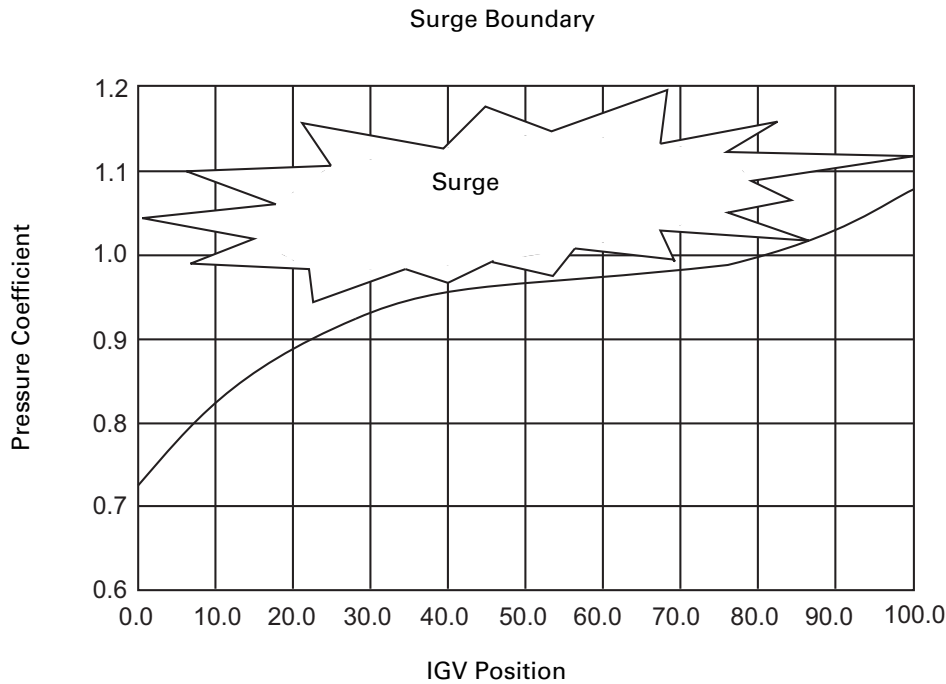
**Figure 12. Pressure coefficient surge boundary**

### AFD Speed Control

UC800 control utilizes an enhanced control method capable of simultaneously adjusting compressor speed and inlet guide vane position to achieve the desired chiller capacity and pressure coefficient. At the heart of the control is a match model that describes the relationship between control parameters and actuators. This model has converted a complicated multi variable control problem to a system of algebraic equations. The equations cannot be solved directly, so a binomial search algorithm is used iteratively to find a solution. A new solution is found every 5 seconds. This is possible because of the increased performance of the microprocessor available with the UC800.

### Startup

The starting speed for AFD under UC800 control will vary depending upon the pressure ratio across the compressor. The UC800 predicts the condensing pressure during startup and sets the AFD at a speed that will support the predicted pressure ratio across the compressor. The UC800 makes this correction by converting condenser water temperature to a pressure and comparing it to a measured pressure. The UC800 uses the greater of the two pressures for the initial speed command. After the compressor runs for a few minutes, the actual condenser pressure is used. The speed will be adjusted every 5 seconds in response to changing pressure ratio and load requirements.

On startup, shell pressures and temperatures may not correspond to saturated conditions. To avoid potential surge on start, the boundary pressure coefficient will be reduced by 0.2 below the last running condition, and over 40 minutes adjusts itself towards the last running condition. This allows for the stabilization of pressures and water loop conditions. After reaching this condition the control will do a re-optimization.

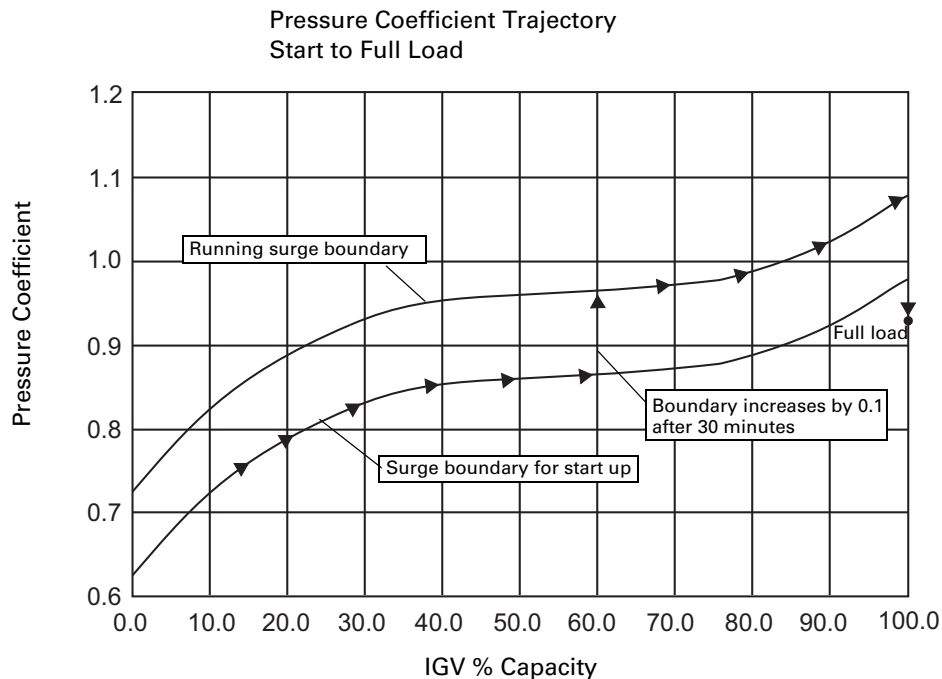
**Figure 13. Startup surge boundary**

## Re-optimization

The AF Surge Boundary Offset Coefficient is a user settable parameter to be used for adjusting the surge boundary either higher or lower. In addition to being user settable, the surge control algorithm will periodically readjust this boundary. This re-optimization will occur when any of three different criteria are met.

1. After startup stabilization the control will re-optimize unless the surge is detected in that time period.
2. Every 30 minutes, the control will compare the current IGV position with the IGV position at the end of the last re-optimization time and, if greater than the user adjustable sensitivity, will re-optimize.
3. When the re-optimization timer expires.

The control is re-optimized by increasing the AF Surge Boundary Offset Coefficient every minute until surge occurs. When surge occurs, the control will go into surge recovery until the surge flag is removed and all of the re-optimization timers will reset.

**Figure 14. Boundary re-optimization**

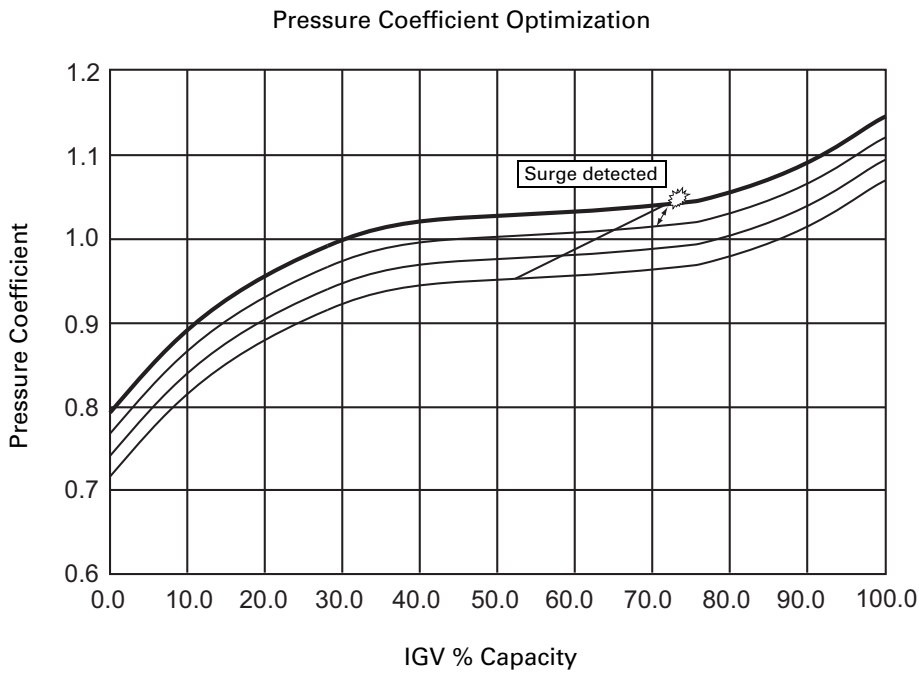

## Surge Recovery

When surge occurs, the pressures in the evaporator and condenser shells can become erratic. Surge recovery is needed to force conditions out of this unstable operating point. This is accomplished by reducing the pressure coefficient every 90 seconds of continuous surge. In addition, when the surge flag is set, the compressor speed command is increased by 1 Hz every 5 seconds until the surge condition clears. When the surge flag is removed, the speed command will relax back to the speed needed to raise the pressure coefficient to the new surge boundary.

## Surge Detection

Surge detection control logic monitors changes in compressor motor current. A surge occurrence leaves a characteristic motor current signature as shown in [Figure 15](#). This signature is formed because the transitory pressure breakdown between the condenser and evaporator causes a sudden reduction in compressor motor load. As the pressures equalize, the compressor begins to quickly load, increasing the motor current.

**Figure 15. Motor current signature representing surge**

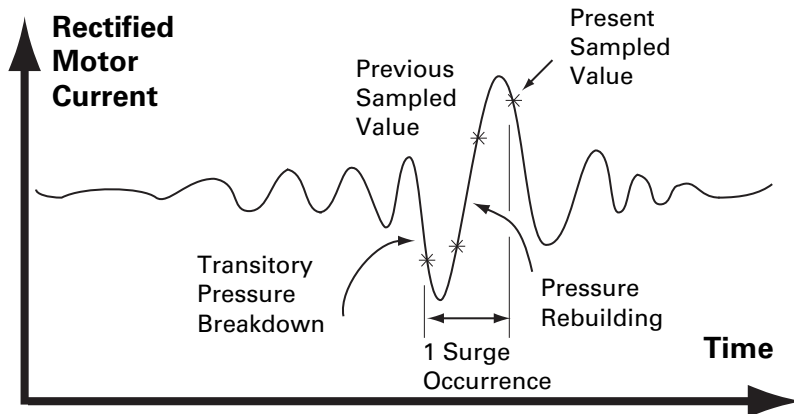

## UC800 Interface to Adaptive Frequency Drive

The UC800 provides a "Start" contact closure output to command the Adaptive Frequency Drive to begin its start sequence. A 2–10 Vdc analog speed signal output is provided by the UC800 to provide a speed reference to the

drive. The UC800 also provides both "Fault" and "Up-to-Speed" (transition complete) contact closure inputs for variable frequency drive starters.

At start of the compressor motor, a signal corresponding to normal line frequency (Full Speed) is applied to the speed signal input of the drive.

**Figure 16. Drive frequency vs. speed reference signal**

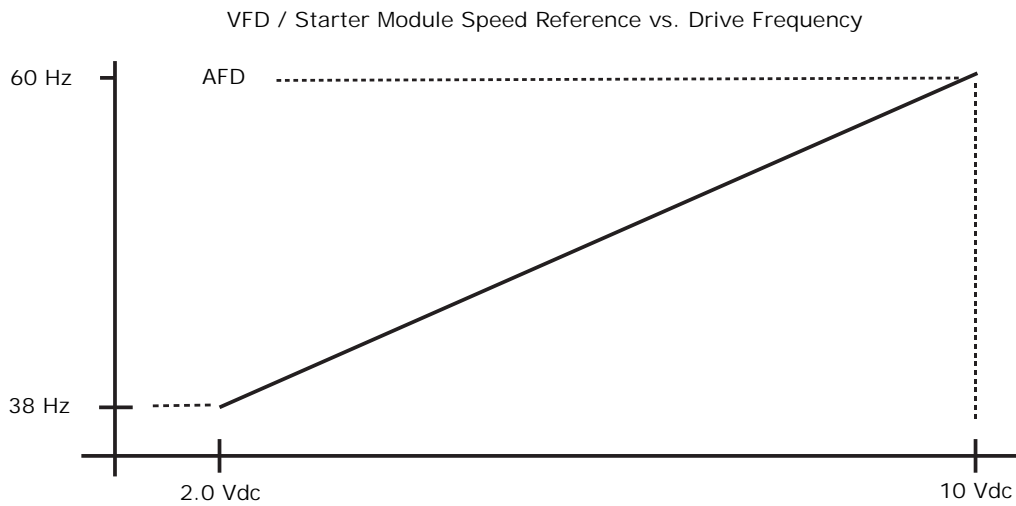

**Figure 17. AFDG starter module to unit mounted inverter interface block diagram**

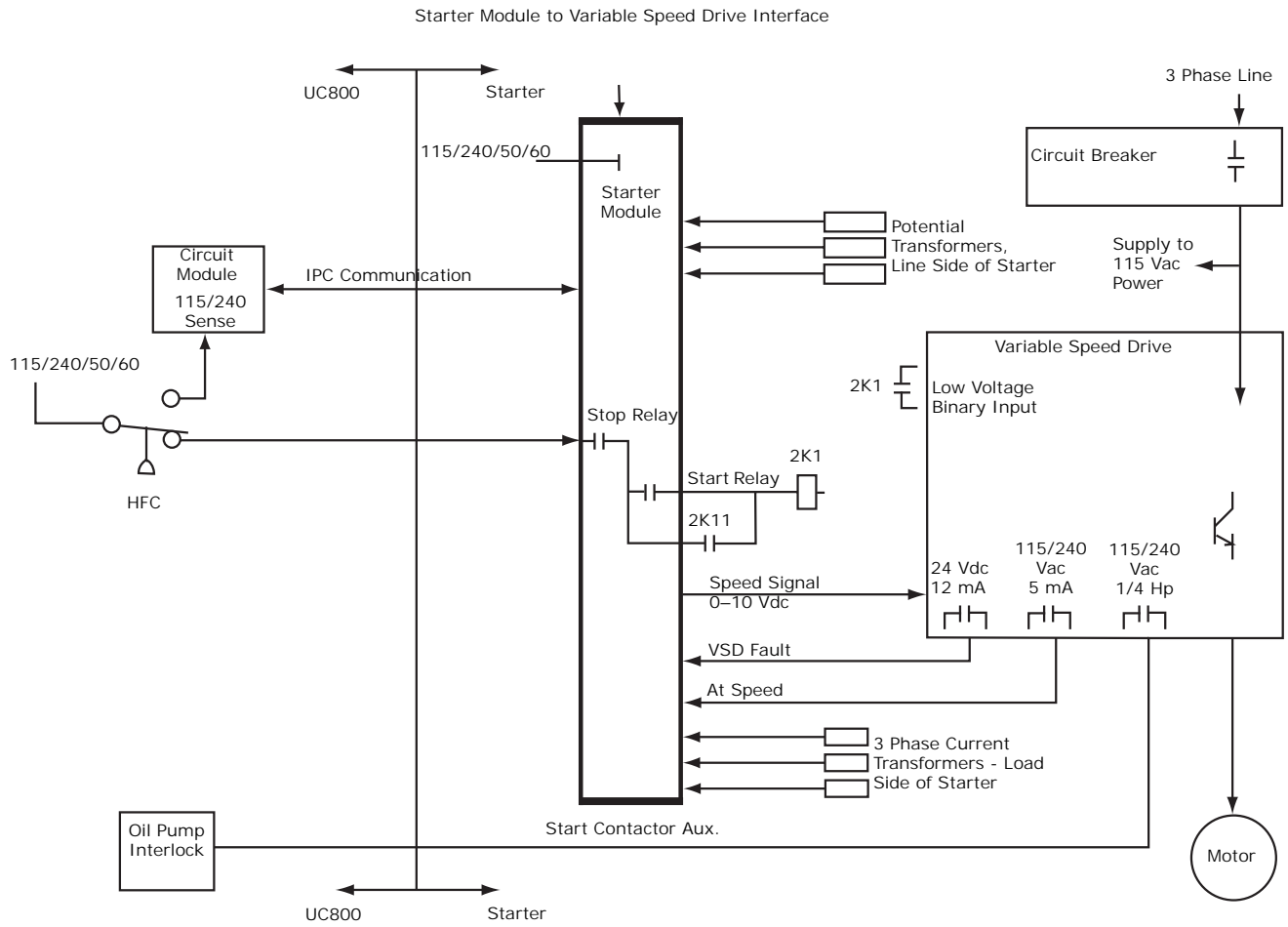

**Figure 18. AFDU starter module to unit mounted inverter interface block diagram**

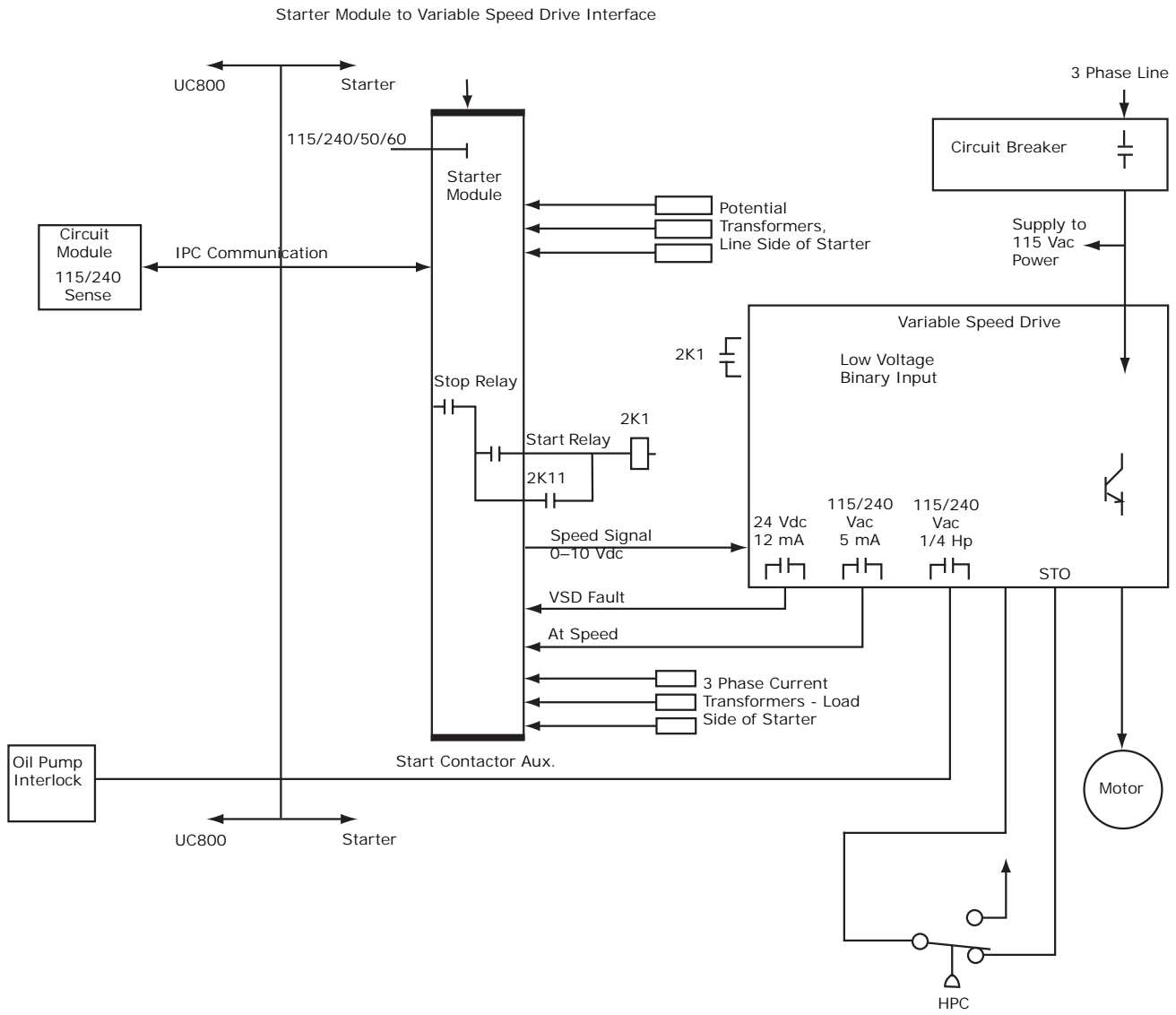



# Service Interface

## AFD Operator Interface

Chiller information is tailored to operators, service technicians, and owners. When operating a chiller, there is specific information you need on a day-to-day basis—setpoints, limits, alarm information, and reports.

When servicing a chiller, you need different information and usually more of it—historic and active alarms, configuration settings, and customizable control algorithms, as well as operation settings.

By providing two different tools—one for daily operation and one for periodic service—everyone has easy access to pertinent and appropriate information.

### Tracer AdaptiView Operator Interface

For the operator’s day-to-day operational information, Tracer® AdaptiView™ displays data (English or SI units) simultaneously on the 12-inch, color touch-sensitive screen. Logically organized groups of information—chiller modes of operation, active alarms, settings and reports put information conveniently at your fingertips. The AFD status can be viewed from the Tracer® AdaptiView™ MOTOR target area on the home page. Refer to the *Tracer*

*AdaptiView Display for CenTraVac Chillers, Daily Operations* manual (CTV-SVU01\*-EN) for more information on the Tracer® AdaptiView™ display.

### Tracer TU Service Tool (Laptop Computer)

Tracer® TU is software installed on a portable laptop computer and used, by the service technician or advanced operator, to interface with the UC800 controller on the CenTraVac™ chiller. When you need more detailed information about a Trane® chiller, connect your laptop computer (with the Tracer® TU software installed) to the UC800’s “Service Tool” USB plug-in port (this port is extended to exterior of the control panel cabinet for easy access).

The Tracer® TU software provides access to that particular machine’s configuration settings, customizable limits, status, and up to 60 active or historic alarms. A technician can interact with an individual device or a group of devices for advanced troubleshooting. For more information on Tracer® TU, visit your local Trane Service company, or Trane’s website at [www.Trane.com](http://www.Trane.com).

Use Tracer® TU when a factory or startup setting requires field alterations.

**Table 5. The following Adaptive Frequency Drive (AFD) information is available from the Tracer AdaptiView display:**

Tracer® AdaptiView™ Display	MENU items	Units	Comments
Reports - Motor (AFD items)	AFD Frequency	Hz	
Settings - Mode Overrides	Oil Pump Manual Control	Auto/On	Oil pump manual control
	Chiller Control Signal	Auto/Manual	Manual control allows the user to override the automatic signal and manually drive the Compressor Control Signal from 0–100%. The limits and safeties remain active. The compressor control signal controls a calculated combination vanes position and drive speed for leaving water control signal.

**Note:** Both motor report and mode overrides contain chiller content along with the AFD related items identified above.

**Table 6. Tracer TU: Service Setpoints view: Adjustable Frequency Drive Setpoints section**

Description	Min	Max	Factory Default	Units
AF Control	N/A	N/A	(Auto, Fixed) <b>Auto</b>	N/A
Re-Optimization Sensitivity	0	100	20%	Percent

**Notes:**

1. Use only Factory Defaults. Defaults other than above may effect chiller reliability
2. **AF Re-optimization Sensitivity** - Every 30 minutes the optimizing algorithm compares the current value of the inlet guide vane position to the value that was stored after the last re-optimization. If the difference is greater than the AF Re optimization Sensitivity setting, re-optimization occurs. This value is adjustable from 0 to 100%, where 0 would guarantee re-optimization every 30 minutes and 100% would guarantee no re-optimization.

**Table 7. Tracer TU: Field Startup view: Adjustable Frequency Drive section**

Description	Min	Max	Factory Default	Units
Maximum Frequency	38	60	60	Hertz (Hz)
Minimum Frequency	38	60	38	Hertz (Hz)
AFD Surge Capacity Increase	0	5	1	Hertz (Hz)



**Table 8. Tracer TU: Unit Status overrides**

There is no specific view for overrides. If an item is available for override, the Override icon displays.				
Frequency Command			AFD Frequency:	When Manual is selected, the user can enter AFD Frequency commands

**Table 9. Tracer TU: Configuration view: Starter Expanding section**

UC800 Starter Type: Set to Remote-Mount Non-Comm AFD				
Configuration of Drive				
<b>Note:</b> These items are factory set, and checked at unit commissioning. Do not change without authorization				
Description	Range	Default	Units	Notes
Stop Delay	1–30	3	Seconds	Set to 30
Unit Voltage	180–15000	460	Volts	Nameplate Data
Voltage Transformer Ratio	0–700	20	(a)	Nameplate Data [VTRA]
Rated Load Amps	0–2500	500	Amps	Nameplate Data [RLA <sup>(b)</sup> ]
CT Meter Scale	0–2000	0		Nameplate Data [CTMS]
Current Unbalance Trip Point	15–100	30	Percent	
Current Unbalance Grace Period	10–255	90	Seconds	
Maximum Acceleration Time	6–64	6	Seconds	Set to 30
Acceleration Shutdown Action	Shutdown Transition	Shutdown		
Overload Type	Exponential Linear	Linear		
Phase Reversal	Enable Disable	Enable		(Set to Disable)(a)
Contactors Integrity	Enable Disable	Disable	(a)	(a)
Phase Reversal Grace Period	20–100	700	Seconds	Set to 1000
Surge Protection	Enable Disable	Enable	(a)	(a)
Momentary Power Loss	Enable Disable	Enable	(a)	Set to Disable
Restart Inhibit Stop to Start Time	0–255	30	Seconds	Use the default
Surge Sensitivity	0–100	20	Percent	(a)
Power Loss Reset Time	0–255	60	Seconds	Also Minimum Time Off: Stop to Start.
RTD Type	750 ohm @ 75°F 100 ohm @ 0°C	75 ohm		

(a) Use only the factory settings for this application as they are specific to the sales order. Instability and faults may occur by using other settings and is not recommended. Contact your local Trane representative for service when necessary.

(b) Compressor motor RLA.



# AFDG/AFDU Startup Procedure

## NOTICE

### Perform Visual Inspection!

Before powering up this drive for the first time conduct a visual inspection for the following:

- Shipping damage.
- Signs of moisture.
- Signs of debris or dust from storage.
- Signs of corrosion on components and/or enclosure.

These conditions could cause equipment damage. Do not power up equipment if you have concerns regarding equipment condition. Upon initial power up, remain in the area for the first two hours of operation and observe the chiller and drive for any abnormalities. Contact CenTraVac™ Chiller Technical Support for assistance if needed.

## ⚠ WARNING

### Hazardous Voltage!

Failure to follow the instructions below could result in death or serious injury. Be sure all enclosure doors are closed and properly secured with fasteners when operating equipment.

The air-cooled adaptive frequency drive is remote-mounted (AFDG) or unit-mounted (AFDU) on CenTraVac™ chillers. The remote-mounted AFDG requires some programming in the field; the unit-mounted AFDU is completely programmed at factory. Follow the procedure below when starting the water chiller and drive.

1. The UC800 is the primary controller for the CenTraVac™ chiller and is located in the control panel. The UC800 starts, stops, and monitors all unit and AFDG/AFDU run functions.

Complete all items on the commissioning checklist and in the startup procedures for the chiller as defined in the chiller *Installation, Operation, and Maintenance* manual, or other applicable manual.

## ⚠ WARNING

### Hazardous Voltage w/Capacitors!

Failure to disconnect power and discharge capacitors before servicing could result in death or serious injury. Disconnect all electric power, including remote disconnects and discharge all motor start/run capacitors before servicing. Follow proper lockout/tagout procedures to ensure the power cannot be inadvertently energized. For variable frequency drives or other energy storing components provided by Trane or others, refer to the appropriate manufacturer's literature for allowable waiting periods for discharge of capacitors. Verify with an appropriate voltmeter that all capacitors have discharged.

Failure to follow the instructions below could result in death or serious injury. DC bus capacitors retain hazardous voltages after input power has been disconnected. Follow proper lockout/tagout procedures to ensure the power cannot be inadvertently energized. After disconnecting input power, wait ten (10) minutes for the DC capacitors to discharge and then check the voltage with a voltmeter to ensure the DC bus capacitors are discharged before touching any internal components.

For additional information regarding the safe discharge of capacitors, see *PROD-SVB06\*-EN*

2. Check the following on the drive:
  - a. Make sure input wire sizing to the drive is sized correctly based on unit nameplate voltage, and connected as noted in this manual.
  - b. Check the drive ground connection as detailed in ["Input Power and Control Wiring," p. 19](#), check cabinet wire routing and grounding.
3. Check all drive wiring and connections in the drive to make sure they are tight and free of any shipping damage.
4. AFDG/AFDU control checkout: Use the Tracer® TU service tool.
  - a. Confirm the starter LLID has been properly bound and is recognized by the unit controls. If two starter LLIDs are shown, *unbind both* and then rebind the starter LLID.
  - b. CHILLER Setpoints: As with any new chiller, first check out all UC800 setpoints for the Chiller.
  - c. AFD Setpoints: Check out all AFD setpoints (refer to ["Drive Settings," p. 35](#)).
  - d. AFD Configuration: Verify the correctness of the "Sales Order" specific setpoints in the "Starter Configurations for AFD Starters." These settings are specific to unit/motor combination in the drive. All of the remaining settings are factory-determined default setpoints that are the same on all AFDG/AFDU air-cooled drives.

**Note:** If the set values do not match, contact the local Trane Service agency first, or, the La Crosse Business Unit Technical Service Department. The correct values are listed on the unit nameplate shipped with each unit.

5. In order to view the AFDG/AFDU configurable settings, go to the Chiller Configuration tab in the Tracer® TU service tool and select the AFD expanding section.
6. If the drive LLID is not found or if it is necessary to re-bind the drive LLID, follow the procedure below.
  - a. The drive's main DC bus must be charged in order for the drive LLID to be recognized or bound. Close the drive disconnect and apply line power to the drive.
  - b. With a laptop connected to the chiller and with Tracer® TU running, enter the binding view menu of Tracer® TU and locate the "Starter" LLID in the menu. Select the "Bind" button for the AFD Starter LLID.
  - c. The screen "Is the device alone selected?" displays. In the AFD, wave magnet on the LLID and light the "service" LED.
  - d. On the Tracer® TU screen, select the "yes" button to indicate the LLID has been selected.
  - e. When properly bound, exit the binding view.
  - f. Perform any remaining startup items.
7. When ready, start the drive from the Tracer® AdaptiView™ display.
8. Check the AFDG/AFDU chiller drive response to the UC800. Initially, the drive will go to 38 hertz and stay there until the CenTraVac™ chiller vanes open based on load. The drive will change the speed from there based on load demand.
9. Document all information on the Startup log.

## Drive Settings

Set the values in the order shown in [Table 10](#) based on information obtained from the chiller nameplate.

For additional information, refer to the programming manual that is shipped with the drive. The programming manual includes a detailed section that discusses accessing the parameters in the drive.

This process is summarized briefly below:

1. To access the parameters, press the **Main Menu** key.
2. If required, enter the password (**999**).
3. To select a parameter group, use the up/down arrow keys to highlight the parameter group, and then press the **Enter** key to access that group.
4. Use the up/down arrow keys to access the parameter number, and then press the **OK** key.

5. Use the up/down arrow keys to change the parameter, and then press the **OK** key to change the setting.

**Table 10. Job specific settings**

Group	Parameter	Description	Value
1	20	Motor kW	Set to nameplate CPKW
1	22	Motor voltage	Nameplate voltage
1	24	Motor current	Set to nameplate TVA
1	25	Motor nominal speed	Set to nameplate TRPM
1	30	Stator resistance	Set to nameplate SRES
1	35	Main reactance	Set to nameplate MGRE
4	16	Torque limit mode	Set to maximum
4	18	Current limit	Set to maximum
8(a)	01	Control site	1
8(a)	02	Control word source	0
8(a)	53	Start select	0

(a) If the customer is connecting to the remote-mounted AFDG with MOD-BUS®, Group 8 parameters MUST be selected.

6. If the chiller does not start, re-enter the motor kW, voltage, and current. The stator resistance and main reactance values will change based on the motor table look up that is built into the drive. *If the motor still will not start*, then perform an AMA (the AMA will physically measure the stator resistance and main reactance values, including the connecting cables between the drive and the motor; the values will then be set in the drive when the AMA is complete).

To perform an AMA:

- a. Change the following parameters:
  - 0-40 Hand on key; set to enable.
  - 0-41 Off key; set to enable.
  - 5-12 Terminal 27 digital input; set to 0, no function.
- b. Go to parameter 1-29 automatic motor adaptation (AMA) and enter 1 to enable complete AMA.
- c. Press the hand key "on" to start the AMA. The display should now begin to show the steps completing; there are approximately 16 steps that need to be completed. If the drive displays an Alarm 53, change the motor voltage value in parameter 1-22 (for example, change from 460 volt to 480 volt or visa versa) and then try running the AMA again.
- d. After the AMA is finished, the display will read "Press OK to finish AMA." Press **OK**.

**Important:** After the AMA is finished, set parameters 0-40, 0-41, 5-12, and 1-29 back to their original settings.

7. If the drive is still having difficulty starting the motor, it may be necessary to perform a reset on the drive; this procedure will reset the drive parameters back to the original Danfoss defaults. After this has been completed, first set the parameters in [Table 11](#) and then set the values in [Table 10](#).



## AFDG/AFDU Startup Procedure

- a. To reset the drive to the Danfoss defaults:
  - i. Disconnect power to the drive, and wait for the display to shut down.
  - ii. While powering up the drive, press and hold the following keys: **Status**, **Main**, and **OK**.
  - iii. After 5 seconds, release the keys.
- b. Set Trane default settings (refer to [Table 11](#)).
- c. Set the job specific settings (refer to [Table 10](#)).

### Default Settings

Refer to [Table 11](#) for a list of items that are programmed in the drive at the factory for use with Trane® chillers. In the event that the drive needs to be reset, these parameters will need to be reprogrammed into the drive.

**Note:** *The Trane commissioning technician should verify these default settings to ensure they are correct in the drive.*

**Table 11. Trane default settings**

Group	Parameter	Description	Setting
0	03	Regional Settings	International (0)
0	20	Display line 1.1 small	DC link voltage (1630)
0	21	Display line 1.2 small	Analog input (1662)
0	22	Display line 1.3 small	Heat sink temp (1634)
0	23	Display line 2 large	Power Kw (1610)
0	24	Display line 3 large	Freq Hz (1613)
0	40	Hand on key	Disabled (0)
0	41	Off key	Disabled (0)
0	60	Main Menu password	999
0	61	Access to main menu w/o password	Read only (1)
1	03	Torque characteristics	Variable torque (1)
1	23	Motor frequency	60 Hz
1	39	Motor poles	Poles (2)
1	71	Delay start	0 sec
1	73	Flying start	Disabled (0)
3	03	Maximum Reference	60 Hz
3	41	Ramp 1 ramp up time	10 sec
3	42	Ramp 2 ramp down time	20 sec
4	12	Motor speed low limit	38 Hz
4	14	Motor speed high limit	60 Hz
5	12	Terminal 27 digital input	Coast inverse (2)
5 <sup>(a)</sup>	40	Function Relay	Alarm (9)
6	10	Terminal 53 low voltage	2 volts
6	14	Terminal 53 low Ref./Feedb. value	38 Hz
6	15	Terminal 53 High Ref./Feedb. value	60 Hz
14	20	Reset Mode	Automatic reset x 2
14	21	Automatic Restart Time	60 sec

(a) There are actually two relays under parameter 5-40 (Relay 1 and Relay 2). When entering 5-40, the required setting on Relay 1 = Alarm (9) as shown here but then you also need to scroll down to Relay 2 and confirm that Relay 2 = Run (5). The relays are NOT interchangeable. Relay 1 must always be set to Alarm (9); Relay 2 must always be set to Run (5).



# Startup Test Log

Water-Cooled CenTraVac™ Chiller with Tracer® AdaptiView™ Control and Adjustable Frequency Drive™ (AFD) Starter				
		AFD Serial Number		
Job Location		AFD Model Number		
Sales Order Number		Ship Date		
Chiller Serial Number		Start Date		
Chiller Model Number				
Starter Date:		Tracer® TU: Service Setpoints View: AFD	Default	Setting
Manufacturer		AFD Control	Auto	
Type		Re-Optimization Sensitivity	20%	
Vender ID				
Model Number		UC800 Starter Type: Remote Mount Non-Communicating AFD Tracer® TU: Configuration View: Starter	Trane Default	Setting
Volts & Hz				
Amps				
Motor Data:		Restart Inhibit Stop to Start Time	30	
Manufacturer		Surge Protection	enable	
Type & Frame		Surge Sensitivity	20	
Drawing #		Power Loss Reset Time	60	
Serial Number		Unit Line Voltage	*	
Nameplate Data:		CT Meter Scale	0	
RLA		Stop Delay	3	
KW		Motor NP RLA	*	
Volts & Hz		Voltage Transformer Ratio	20	
Prestart Checks	Date Checked	Current Unbalance Trip Point	30	
Drive Grounded		Acceleration Time	30	
Motor Rotation		Acceleration Shutdown Action	Shutdown	
Drive Chassis Grounded		Overload Type	Linear	
Control Wiring Tight		Phase Reversal	Enable	
Drive Connections are Tight		Contactors Integrity	Disable	
Verified Settings		Phase Reversal Grace Period	700	
		Surge Protection	Enable	
Comments:		Momentary Power Loss	2000	
		Restart Inhibit Stop to Start	30	
		Surge Sensitivity	20	
		Power Loss Reset	15	
		RTD Type	75	
		*Must be set per sales order variable.		
		Test Log Date:	Log 1	Log 2
		AFD Output Power (KW)		
		Speed		
		Frequency		
		Tracer® TU Field Startup View: AFD		
		Maximum Frequency	60	
		Minimum Frequency	38	
		AFD Surge Capacity Increase	1	
		Tracer® TU Status View: Motor		
		Average Line Current		
		Starter Average Phase Voltage		
		Starter Load Power Factor		
		Motor Winding #1 temp		
		Motor Winding #2 temp		
		Motor Winding #3 temp		



# Recommended Periodic Maintenance and Inspection

## Visual Inspection—Power Removed

### ⚠ WARNING

#### Hazardous Voltage w/Capacitors!

Failure to disconnect power and discharge capacitors before servicing could result in death or serious injury. Disconnect all electric power, including remote disconnects and discharge all motor start/run capacitors before servicing. Follow proper lockout/tagout procedures to ensure the power cannot be inadvertently energized. For variable frequency drives or other energy storing components provided by Trane or others, refer to the appropriate manufacturer's literature for allowable waiting periods for discharge of capacitors. Verify with an appropriate voltmeter that all capacitors have discharged.

For additional information regarding the safe discharge of capacitors, see PROD-SVB06\*-EN

8. Ensure the door interlocks are present and working.
9. Verify the safety ground connections to the door panels are securely connected.
10. Inspect power wire cables and devices to assure no abrasion is occurring from vibrations against chassis of cabinets, or other edges.
11. Ensure the drive interior and exterior is clear of any dust or debris. Fans, circuit boards, vents etc. must be clean. Only use a vacuum for cleaning. DO NOT use compressed air.
12. Inspect the interior of the drive for any signs of moisture entry or leakage.
13. Visually inspect all drive components and wiring. Look for signs of heat or failure (look for swelled or leaking capacitors, discolored reactors or inductors, broken pre-charge resistors, smoke or arc trails on MOVs and capacitors, etc.).
14. Closely inspect the motor terminal board for any signs of leakage, arcing, etc.
15. Check ALL cable/lug/terminal connections inside the drive enclosure. Ensure all are clean and tight, and not rubbing against each other anywhere.

### ⚠ WARNING

#### Live Electrical Components!

Failure to follow all electrical safety precautions when exposed to live electrical components could result in death or serious injury. When necessary to work with live electrical components, have a qualified licensed electrician or other individual who has been properly trained in handling live electrical components perform these tasks.

## Operational Inspection—Power Applied

1. Verify the drive cabinet cooling fans are operating.  
This should be done from outside the enclosure, by looking into the cabinet at door and cabinet vents, to avoid electrical hazards.  
**Note:** *The power module fan comes on with power. Other fans cycle with drive operation.*
2. Check historic fault codes using Local Control Panel (LCP) connected to the AFD.
3. Check configuration settings and confirm all proper settings are still present in the controls.
4. Review the diagnostic history.
5. Make Chiller Service report to document all setpoints.
6. Check the UC800 alarm histories for any indications of operational problems.

### Do this every 1–12 months depending on operating environment

To properly diagnose service issues for Adaptive Frequency drives for centrifugal chillers equipped with AFDG/AFDU starters. All UC800 chillers will be equipped with the LCP as standard on the drive power module. This is for service only and NEVER for machine operation.

### Do as needed

Replace the magnetic choke if there is physical damage (for example, cracks).

## Chiller Operator Display Content

Refer to *Operations Guide: Tracer AdaptiView Display for Water-Cooled CenTraVac Chillers* (CTV-SVU01\*-EN, or the most recent version) for Tracer® AdaptiView™ display information.

**Important:** *Please note that the Tracer® AdaptiView™ displayed voltage is **line side input voltage**, whereas current and power factor*



# Troubleshooting

In the event that there is a problem with the drive, a starter diagnostic appears on the Tracer® AdaptiView™ display. This occurs when the drive fault contacts open in the drive on the 2A10 module. If this occurs, the next step is to refer to the AFD Local Control Panel (LCP) to determine the type of fault that has occurred in the drive.

The drive displays three types of faults:

- **Warning**

A warning or alarm is signaled by the LEDs on the front of the AFD by a code on the LCP.

A warning indicates a condition that may require attention or a trend that may eventually require attention, and will remain active until the cause is no longer present. Under some circumstances, motor operation may continue.

- **Trip**

A trip is the action when an alarm has appeared. The trip removes power to the motor and, after the condition has been cleared, can be reset by pressing the **Reset** button. The event that caused an alarm cannot damage the AFD or cause a dangerous condition.

After its cause has been rectified, an alarm must be reset to restart operation.

- **Trip Lock**

A trip lock is an action when an alarm occurs that may cause damage to the AFD or equipment. Power is removed from the motor, and a trip lock can only be reset after the condition is cleared by cycling power.

Once the problem has been rectified, only the alarm continues flashing until the AFD is reset.

- b. Record all UC800 active and historic alarms. Make a full chiller service report.
  - c. Document and check all applicable parameter settings. This information can be verified from the chiller nameplate, and by referring to this manual.
  - d. In the Binding view of the Tracer® TU service tool, verify there is a green circle indicating that the Starter LLID is bound.
  - e. Record any drive diagnostics found.
2. Collect Chiller Information.
- a. Note the following chiller information:
    - Operating mode and any sub-mode (i.e., 100 percent or 75 percent load etc.)
    - Number of chiller starts, and hours of operation.
    - Time since last diagnostic shutdown (<1 minute, <1 hour, >1 hour, etc.)
  - b. What was the chiller state at the time of the failure? (Chiller starting? Running low load? Running full load? etc.)
  - c. Record the chiller's sales order and serial numbers, & the drive's serial and model numbers.
3. Troubleshooting
- a. Measure and record the DC bus (via the LCP).
  - b. Check ALL wiring (tightness, ribbon cables fully seated, proper phasing, etc.)
  - c. Refer to the Danfoss manuals for further troubleshooting information.

## **⚠ WARNING**

### **Hazardous Voltage w/Capacitors!**

**Failure to disconnect power and discharge capacitors before servicing could result in death or serious injury. Disconnect all electric power, including remote disconnects and discharge all motor start/run capacitors before servicing. Follow proper lockout/tagout procedures to ensure the power cannot be inadvertently energized. For variable frequency drives or other energy storing components provided by Trane or others, refer to the appropriate manufacturer's literature for allowable waiting periods for discharge of capacitors. Verify with an appropriate voltmeter that all capacitors have discharged.**

*For additional information regarding the safe discharge of capacitors, see PROD-SVB06\*-EN*

1. Collect alarm and parameter information.
  - a. DO NOT cycle unit power or reset the controls. Leave AFD and UC800 in their present states.



## Wiring Schematics

For reference, an as-built schematic wiring diagram and a field wiring connection diagram are located inside the main control panel door of the chiller.









Trane - by Trane Technologies (NYSE: TT), a global climate innovator - creates comfortable, energy efficient indoor environments for commercial and residential applications. For more information, please visit [trane.com](http://trane.com) or [tranetechnologies.com](http://tranetechnologies.com).

Trane has a policy of continuous product and product data improvement and reserves the right to change design and specifications without notice. We are committed to using environmentally conscious print practices.