



Installation, Operation, and Maintenance

Ascend™ Air-Cooled Chiller

Models ACS and ACX

With Symbio™ Controls
140 to 230 Nominal Tons



⚠ SAFETY WARNING

Only qualified personnel should install and service the equipment. The installation, starting up, and servicing of heating, ventilating, and air-conditioning equipment can be hazardous and requires specific knowledge and training. Improperly installed, adjusted or altered equipment by an unqualified person could result in death or serious injury. When working on the equipment, observe all precautions in the literature and on the tags, stickers, and labels that are attached to the equipment.



Introduction

Read this manual thoroughly before operating or servicing this unit.

Warnings, Cautions, and Notices

Safety advisories appear throughout this manual as required. Your personal safety and the proper operation of this machine depend upon the strict observance of these precautions.

The three types of advisories are defined as follows:



Indicates a potentially hazardous situation which, if not avoided, could result in death or serious injury.



Indicates a potentially hazardous situation which, if not avoided, could result in minor or moderate injury. It could also be used to alert against unsafe practices.



Indicates a situation that could result in equipment or property-damage only accidents.

Important Environmental Concerns

Scientific research has shown that certain man-made chemicals can affect the earth's naturally occurring stratospheric ozone layer when released to the atmosphere. In particular, several of the identified chemicals that may affect the ozone layer are refrigerants that contain Chlorine, Fluorine and Carbon (CFCs) and those containing Hydrogen, Chlorine, Fluorine and Carbon (HCFCs). Not all refrigerants containing these compounds have the same potential impact to the environment. Trane advocates the responsible handling of all refrigerants.

Important Responsible Refrigerant Practices

Trane believes that responsible refrigerant practices are important to the environment, our customers, and the air conditioning industry. All technicians who handle refrigerants must be certified according to local rules. For the USA, the Federal Clean Air Act (Section 608) sets forth the requirements for handling, reclaiming, recovering and recycling of certain refrigerants and the equipment that is used in these service procedures. In addition, some states or municipalities may have additional requirements that must also be adhered to for responsible management of refrigerants. Know the applicable laws and follow them.

⚠ WARNING

Proper Field Wiring and Grounding Required!

Failure to follow code could result in death or serious injury.

All field wiring **MUST** be performed by qualified personnel. Improperly installed and grounded field wiring poses **FIRE** and **ELECTROCUTION** hazards. To avoid these hazards, you **MUST** follow requirements for field wiring installation and grounding as described in **NEC** and your local/state/national electrical codes.

⚠ WARNING

Personal Protective Equipment (PPE) Required!

Failure to wear proper PPE for the job being undertaken could result in death or serious injury.

Technicians, in order to protect themselves from potential electrical, mechanical, and chemical hazards, **MUST** follow precautions in this manual and on the tags, stickers, and labels, as well as the instructions below:

- **Before installing/servicing this unit, technicians MUST put on all PPE required for the work being undertaken (Examples; cut resistant gloves/sleeves, butyl gloves, safety glasses, hard hat/bump cap, fall protection, electrical PPE and arc flash clothing). ALWAYS refer to appropriate Safety Data Sheets (SDS) and OSHA guidelines for proper PPE.**
- **When working with or around hazardous chemicals, ALWAYS refer to the appropriate SDS and OSHA/GHS (Global Harmonized System of Classification and Labelling of Chemicals) guidelines for information on allowable personal exposure levels, proper respiratory protection and handling instructions.**
- **If there is a risk of energized electrical contact, arc, or flash, technicians MUST put on all PPE in accordance with OSHA, NFPA 70E, or other country-specific requirements for arc flash protection, PRIOR to servicing the unit. NEVER PERFORM ANY SWITCHING, DISCONNECTING, OR VOLTAGE TESTING WITHOUT PROPER ELECTRICAL PPE AND ARC FLASH CLOTHING. ENSURE ELECTRICAL METERS AND EQUIPMENT ARE PROPERLY RATED FOR INTENDED VOLTAGE.**

⚠ WARNING**Follow EHS Policies!**

Failure to follow instructions below could result in death or serious injury.

- All Trane personnel must follow the company's Environmental, Health and Safety (EHS) policies when performing work such as hot work, electrical, fall protection, lockout/tagout, refrigerant handling, etc. Where local regulations are more stringent than these policies, those regulations supersede these policies.
- Non-Trane personnel should always follow local regulations.

⚠ WARNING**R-454B Flammable A2L Refrigerant!**

Failure to use proper equipment or components as described below could result in equipment failure, and possibly fire, which could result in death, serious injury, or equipment damage.

The equipment described in this manual uses R-454B refrigerant which is flammable (A2L). Use ONLY R-454B rated service equipment and components. For specific handling concerns with R-454B, contact your local representative.

⚠ WARNING**Electrical Shock Hazard!**

Failure to follow instructions below could result in death or serious injury.

Properly connect the system's oversized protective earthing (grounding) terminal.

Copyright

This document and the information in it are the property of Trane, and may not be used or reproduced in whole or in part without written permission. Trane reserves the right to revise this publication at any time, and to make changes to its content without obligation to notify any person of such revision or change.

Trademarks

All trademarks referenced in this document are the trademarks of their respective owners.

Factory Training

Factory training is available through Trane University™ to help you learn more about the operation and maintenance

of your equipment. To learn about available training opportunities contact Trane University™.

Online: www.trane.com/traneuniversity

Phone: 855-803-3563

Email: traneuniversity@trane.com

Factory Warranty Information

Compliance with the following is required to preserve the factory warranty:

All Unit Installations

Start-up MUST be performed by Trane, or an authorized agent of Trane, to VALIDATE this WARRANTY. Contractor must provide a two-week start-up notification to Trane (or an agent).

Product Safety Information

This appliance is not intended for use by persons (including children) with reduced physical, sensory or mental capabilities, or lack of experience and knowledge, unless they have been given supervision or instruction concerning use of the appliance by a person responsible for their safety. Children should be supervised to ensure that they do not play with the appliance.

Maximum altitude of use 3000 meters.

This appliance incorporates an earth connection for functional purposes only.

Revision History

- Added Electrical Shock Hazard statement in Front Matter.
- Moved A2L Work Procedures section after Weights topic.
- Updated General data – ACS (IP), ACS (SI), ACX (I-P) and ACX (SI) tables in General Data chapter.
- Updated Low Evaporator Refrigerant Cutout, Percent Glycol Requirements topic in Installation – Mechanical chapter.
- Updated NEC number 310.15(B)(C) in step 3 Wiring in Ascend™ ACS and ACX Installation Completion Check Sheet and Request for Trane Service.
- Updated Digit 14 in Model Number Descriptions chapter.
- Updated Installation Requirements topic in Pre-Installation chapter.
- Updated Service Clearance topic in Dimensions and Weights chapter.
- Updated Evaporator Damage Notice statement in Heat Power Supply topic in Installation Electrical chapter.
- Updated Tracer TU topic in Controls chapter.



Table of Contents

Model Number Information	6	Foundation	24
Nameplates	6	Clearances	24
Unit Nameplate	6	Lifting and Moving Instructions	24
Model Number Coding System	6	Isolation and Sound Emission	25
Compressor Nameplate	6	Unit Isolation and Leveling	25
Model Number Descriptions	7	Elastomeric Isolators	26
Unit Model Number	7	Mounting Locations, Weights, Isolators	26
Compressor Information	9	Evaporator Piping	28
Model Number	9	Evaporator Piping Components	28
General Information	10	Evaporator Label	30
Unit Description	10	Evaporator Head Loss	31
General Data	10	Freeze Avoidance	32
Pre-Installation	15	Low Evaporator Refrigerant Cutout, Percent Glycol Requirements	33
Unit Inspection	15	Pump Package	36
Exterior Inspection	15	Pump Package Available Head and Net Positive Suction Head (NPSH) Required	37
Inspection for Concealed Damage	15	Expansion Tank	42
Repair	15	Installation Electrical	43
Unit Storage	15	General Recommendations	43
Installation Requirements	16	Installer-Supplied Components	43
Dimensions and Weights	17	Power Supply Wiring	43
Unit Dimensions	17	Control Power Supply	44
Standard Unit	17	Heater Power Supply	44
Units with Pump Package Option	18	Interconnecting Wiring	44
Service Clearance	19	Chilled Water Pump Control	44
Weights	20	Lead/Lag Dual Pump	45
A2L Work Procedures	21	Programmable Relays	45
Servicing	21	Relay Assignments Using Tracer TU	46
Ignition Source Mitigation	21	Low Voltage Wiring	46
Ventilation	21	Emergency Stop	46
Refrigerating Equipment	21	External Auto/Stop	46
Electrical Devices	21	Ice Building Option	47
Leak Detection	22	External Chilled/Hot Water Setpoint (ECHWS) Option	47
Refrigerant Removal and Evacuation	22	External Demand Limit Setpoint (EDLS) Option	47
Refrigerant Charging	22	EDLS and ECHWS Analog Input Signal Wiring	48
Decommissioning	23	Chilled Water Reset (CWR)	48
Installation - Mechanical	24		
Location Requirements	24		
Sound Considerations	24		

Communications Interface	49	Maintenance	60
LonTalk Interface (LCI-C)	49	Recommended Maintenance	60
BACnet Interface (BCI-C)	49	Weekly	60
Modbus Remote Terminal Unit		Monthly	60
Interface	49	Annual	60
Operating Principles	50	Refrigerant and Oil Charge	
General	50	Management	61
Refrigerant Cycle	50	Lubrication System	61
Oil System	50	Oil Level	61
Condenser and Fans	50	Oil Testing	61
Controls	51	Condenser Maintenance	61
Overview	51	Condenser Coil Cleaning	61
Symbio™ 800	51	Repair/Replacement of Microchannel	
AdaptiView™ Display	51	Coil	62
Tracer TU	51	Condenser Coil Corrosion Protection	
Pre-Start	52	Inspection	62
Start-up and Shutdown	53	Evaporator Maintenance	62
Unit Start-up	53	Water Strainer Maintenance	62
Temporary Shutdown And Restart	53	Units without Pump Package	62
Extended Shutdown Procedure	53	Units with Pump Package	62
Seasonal Unit Start-up Procedure	54	Pump Package Maintenance	63
System Restart After Extended		Diagnostics	64
Shutdown	54	General Diagnostics Information	64
Sequence of Operation	55	Main Processor Diagnostics	64
Software Operation Overview	55	Sensor Failure Diagnostic	69
Power Up Diagram	55	Communication Diagnostics	70
Power Up to Starting	57	Unit Wiring	74
Stopped to Starting	58	Log and Check Sheets	75
Normal Shutdown to Stopped or Run		Ascend™ ACS and ACX Installation	
Inhibit	59	Completion Check Sheet and Request for	
		Trane Service	76



Model Number Information

Nameplates

Unit nameplates are applied to the exterior of the control panel. A compressor nameplate is located on each compressor. When the unit arrives, compare all nameplate data with ordering, submittal, and shipping information.

Unit Nameplate

The outdoor unit nameplate provides the following information:

- Unit model and size description.
- Unit serial number.
- Unit electrical requirements.
- Operating charges of R-454B and refrigerant oil.
- Unit design pressures.
- Installation, operation and maintenance and service data literature.
- Drawing numbers for unit wiring diagrams

Figure 1. Unit nameplate

Model Number Coding System

Model numbers are composed of numbers and letters that represent features of the equipment. Shown below is a sample of typical unit model number.

ACSA 1802 EUA0 XUXA XNB2 ACAH SMEX 1TAB LXTA X1X4 XX0

Each position, or group of positions, in the model number is used to represent a feature. Unit model number digits are selected and assigned in accordance with the definitions as listed in Model Number Descriptions chapter. For example, position 09 of the unit model number above contains the letter “E” which indicates the unit voltage is 460/60/3.

Compressor Nameplate

The compressor nameplate provides the following information:

- Compressor model number.
- Compressor serial number.
- Compressor electrical characteristics
- Utilization range.
- Recommended refrigerant

See Model Number Descriptions chapter for compressor model and serial number descriptions.



Model Number Descriptions

Unit Model Number

Digit 1, 2, 3, 4 — Unit Model

ACSA = Air-Cooled Scroll Chiller
ACXA = Air-Cooled Scroll Heat Pump Chiller

Digit 5, 6, 7 — Nominal Tonnage

140 = 140 Tons
160 = 160 Tons
180 = 180 Tons
200 = 200 Tons
215 = 215 Tons
230 = 230 Tons

Digit 8 — Compressor Type

2 = Scroll with Variable Volume Ratio

Digit 9— Unit Voltage

A = 200V/60Hz/3 phase
B = 230V/60Hz/3 phase
C = 380V/60Hz/3 phase
D = 400V/60Hz/3 phase
E = 460V/60Hz/3 phase
F = 575V/60Hz/3 phase

Digit 10— Manufacturing Location

U = Trane Commercial Systems, Pueblo, CO USA

Digits 11, 12 — Design Sequence

** = Factory assigned

Digit 13 — Unit Sound Package

X = Standard Unit
L = Superior
R = Standard with Noise Reduction Request
Q = Superior with Noise Reduction Request

Digit 14 — Agency Listing

E = ETL Listed/Certified to CSA/Conforms to UL
C = No Agency Listing

Digit 15 — Pressure Vessel Code

X = Not Applicable
C = CRN or Canada Equivalent

Digit 16 — Factory Charge

L = Refrigerant Charge R-454B
M = Nitrogen Charge (R-454B Field Supplied)

Digit 17 — Auxiliary Items

X = No Auxiliary Items
D = Condenser Drain Pan - HP Units Only

Digit 18 — Evaporator Application

N = Standard Cooling
P = Low Temp Process Cooling
F = Lower Temp Process Cooling
C = Ice Making

Digit 19, 20 — Evaporator Type

B2 = Brazed Plate Heat Exchanger (Standard)

Digit 21 — Water Connection

X = Grooved Pipe
A = Grooved Pipe + Flange Adapter

Digit 22 — Flow Switch Set Point

C = Flow Switch Setpoint 15
F = Flow Switch Setpoint 35
H = Flow Switch Setpoint 45
L = Flow Switch Setpoint 60

Digit 23 — Insulation

N = Standard 0.75 inch
H = Evaporator-Only 1.25 inch humidity/low evap

Digit 24 — Unit Application

X = Standard Ambient
L = Low Ambient
H = High Ambient
W = Wide Ambient

Digit 25 — Condenser Length

S = Standard

Digit 26 — Condenser Fin Options

M = Aluminum Microchannel
C = CompleteCoat™ Microchannel
R = Copper Round Tube, Aluminum Plate Fin
K = Coated Copper Round Tube, Aluminum Plate Fin

Digit 27 — Fan Type

E = EC Condenser Fan Motors
F = Fixed Speed Fans

Digit 28 — Compressor Starter

X = Across-the-Line Starter

Digit 29 — Incoming Unit Power Line Connection

1 = Single Point Unit Power Connection

Digit 30 — Power Line Connection Type

T = Terminal Block
C = Circuit Breaker
M = High Fault Rated Circuit Breaker with Energy Meter
H = High Fault Rated Circuit Breaker

Digit 31 — Short Circuit Current Rating

A = Default Short Circuit Rating
B = High Short Circuit Rating

Digit 32 — Electrical Accessories

X = None
U = Under/Over Voltage Protection
N = 20A - 115V Convenience Outlet
B = Convenience Outlet and Under/Over Voltage Protection

Digit 33 — Remote Communications Options

X = None
B = BACnet® Interface (MS/TP)
p = BACnet® Interface (IP)
M = Modbus™ Interface
L = LonTalk® Interface

Digit 34 — Hard Wire Communication

X = None
A = Hard Wired Bundle — All

Digit 35 — Smart Flow Control

X = None
T = Variable Primary Flow (Constant Delta T)

Digit 36 — Structural Options

A = Standard Unit Structure

Digit 37 — Appearance Options

X = No Appearance Options
A = Architectural Louvered Panels



Model Number Descriptions

Digit 38 — Unit Isolation

X = None
1 = Elastomeric Isolators

Digit 39 — Shipping Package

X = No Shipping Package
F = Shipped with Fork Pocket
T = Tarp Covering Full Unit

Digit 40 — Pump Package

X = No Pump Option
2 = Single Pump, High Pressure, Single VFD
4 = Dual Pump, High Pressure, Dual VFD

Digit 41 — Not Used

Digit 42— Not Used

X = Selection1

Digit 43 — Special Requirement

0 = None
S = Special Requirement
F = Ship to Final Finisher

Digit 44 — Harmonic Filter

N = No Harmonic Filter

Digit 45 — Wireless Connectivity

X = None
A = Wi-Fi
B = LTE Modem
C = Air-Fi
D = Wi-Fi and LTE Modem
E = Wi-Fi and Air-Fi
F = LTE Modem and Air-Fi
G = Wi-Fi, LTE Modem, and Air-Fi

Compressor Information

Model Number

Digit 1, 2, 3 — Compressor Type

DSH = Danfoss

Digit 4, 5, 6 — Capacity

381 = 30 tons

485 = 40 tons

Digit 7 — Agency Approval

A = UL

Digit 8 — Voltage

3 = 200–230V/60Hz/3 phase

4 = 460V/60Hz/3 phase

7 = 575V/60Hz/3 phase

9 = 380V–400V/60Hz/3 phase

Digit 9, 10 — Custom

AT = Trane Pueblo



General Information

Unit Description

Ascend™ Model ACS and ACX units are scroll type, air-cooled, liquid chillers, designed for installation outdoors. Each unit has two independent refrigerant circuits, with two or three compressors per circuit. The chillers are packaged with an evaporator and condenser.

Note: Each unit is a completely assembled, hermetic -compressors packaged unit that is factory-piped, wired, leak-tested, dehydrated, charged and tested for proper control operations prior to shipment. The chilled water inlet and outlet openings are covered for shipment.

The chiller features Tracer® Symbio 800 controls to monitor the control variables that govern the operation of the chiller unit. Adaptive Control logic can correct these variables, when necessary, to optimize operational efficiencies, avoid chiller shutdown, and keep producing chilled water. Each refrigerant circuit is provided with filter, sight glass, electronic expansion valve, and charging valves. The evaporator is a brazed plate heat exchanger equipped with water drain and vent connections in the water piping. The condenser is an air-cooled slit or serpentine fin coil, arranged in a transverse V layout.

General Data

Table 1. General data - ACS (IP)

Unit Size (tons)		140	160	180	200	215	230
Refrigerant		R-454B					
Compressor Model							
Quantity	#	4	4	6	6	6	6
Tonnage/ckt ^(a)		30+40	40+40	30+30+30	30+30+40	40+40+30	40+40+40
Evaporator							
Water storage - Standard Cooling	gal	17.4	17.4	17.4	17.4	17.4	21.6
Min. flow ^(b)	gpm	168	192	216	240	258	276
Max. flow ^(b)	gpm	504	576	648	720	774	828
Water storage - Other Applications	gal	14	14	14	14	14	14
Water connection	in.	4	4	4	4	4	4
Max. Water Temperature	°F	105	105	105	105	105	105
Min. Water Pressure	psig	0	0	0	0	0	0
Max. Water Pressure	psig	150	150	150	150	150	150
Condenser							
Quantity of coils	#	8	8	10	10	12	12
Coil length	in.	75	75	75	75	75	75
Coil height	in.	49	49	49	49	49	49
Tube width	in.	1	1	1	1	1	1
Fins per foot	fpf	276	276	276	276	276	276
Fan							
Quantity	#	8	8	10	10	12	12
Diameter	in.	37.5	37.5	37.5	37.5	37.5	37.5
EC - Airflow per fan	cfm	11338	11336	11337	11336	11338	11336
AC - Airflow per fan	cfm	11644	11642	11643	11642	11644	11642
EC Motor Power per motor	HP	2.4	2.4	2.4	2.4	2.4	2.4
AC Motor Power per motor	HP	1.8	1.8	1.8	1.8	1.8	1.8
EC Motor RPM	rpm	820	820	820	820	820	820
EC Tip speed	ft/min	7728	7728	7728	7728	7728	7728
AC Motor RPM	rpm	840	840	840	840	840	840
AC Tip speed	ft/min	7916	7916	7916	7916	7916	7916
General Unit							
Refrigerant circuits	#	2	2	2	2	2	2

Table 1. General data - ACS (IP) (continued)

Unit Size (tons)		140	160	180	200	215	230
Capacity steps	%	21-43-71-100	25-50-75-100	17-33-50-67-83-100	15-30-50-65-80-100	14-32-50-64-82-100	17-33-50-67-83-100
Min ambient - low/wide	°F	-20	-20	-20	-20	-20	-20
Min ambient - std/high	°F	32	32	32	32	32	32
Refrig charge/ckt ^(a)	lb	50	54	63	63	75	82
Oil charge/ckt ^(a)	gal	3.2	3.2	4.8	4.8	4.8	4.8
Lower Process Cooling - Oil charge/ckt ^(a)	gal	4	4	6	6	6	6

^(a) Data shown for one circuit only. The second circuit always matches.

^(b) Minimum and maximum flow rates apply to constant-flow chilled water system running at AHRI conditions, without freeze inhibitors added to the water loop.

Table 2. General data – ACS (SI)

Unit Size (tons)		140	160	180	200	215	230
Refrigerant		R-454B					
Compressor Model							
Quantity	#	4	4	6	6	6	6
Tonnage/ckt ^(a)		30+40	40+40	30+30+30	30+30+40	40+40+30	40+40+40
Evaporator							
Water storage - Standard Cooling	l	66.0	66.0	66.0	66.0	66.0	81.8
Min. flow ^(b)	l/s	10.6	12.1	13.6	15.1	16.3	17.4
Max. flow ^(b)	l/s	31.8	36.3	40.9	45.4	48.8	52.2
Water storage - Other Applications	l	53	53	53	53	53	53
Water connection	mm	101.6	101.6	101.6	101.6	101.6	101.6
Max. Water Temperature	°C	40.5	40.5	40.5	40.5	40.5	40.5
Min. Water Pressure	kPa	0	0	0	0	0	0
Max. Water Pressure	kPa	1034.2	1034.2	1034.2	1034.2	1034.2	1034.2
Condenser							
Quantity of coils	#	8	8	10	10	12	12
Coil length	mm	1914	1914	1914	1914	1914	1914
Coil height	mm	1252	1252	1252	1252	1252	1252
Tube width	mm	25.4	25.4	25.4	25.4	25.4	25.4
Fins per foot	(fpf)	276	276	276	276	276	276
Fan							
Quantity	#	8	8	10	10	12	12
Diameter	mm	953	953	953	953	953	953
EC - Airflow per fan	m ³ /h	19263	19260	19262	19260	19263	19260
AC - Airflow per fan	m ³ /h	19783	19780	19782	19780	19783	19780
EC Motor Power per motor	kW	1.8	1.8	1.8	1.8	1.8	1.8
AC Motor Power per motor	Kw	1.3	1.3	1.3	1.3	1.3	1.3
EC Motor RPM	rpm	820	820	820	820	820	820
EC Tip speed	m/s	39.3	39.3	39.3	39.3	39.3	39.3
AC Motor RPM	rpm	840	840	840	840	840	840
AC Tip speed	m/s	40	40	40	40	40	40
General Unit							
Refrigerant circuits	#	2	2	2	2	2	2



General Information

Table 2. General data – ACS (SI) (continued)

Unit Size (tons)		140	160	180	200	215	230
Capacity steps	%	21-43-71-100	25-50-75-100	17-33-50-67-83-100	15-30-50-65-80-100	14-32-50-64-82-100	17-33-50-67-83-100
Min ambient - low/wide	°C	-29	-29	-29	-29	-29	-29
Min ambient - std/high	°C	0	0	0	0	0	0
Refrig charge/ckt ^(a)	kg	22.5	24.5	28.5	28.5	34.0	37.0
Oil charge/ckt ^(a)	l	12	12	18	18	18	18
Lower Process Cooling - Oil charge/ckt ^(a)	l	15	15	22.5	22.5	22.5	22.5

^(a) Data shown for one circuit only. The second circuit always matches.

^(b) Minimum and maximum flow rates apply to constant-flow chilled water system running at AHRI conditions, without freeze inhibitors added to the water loop.

Table 3. General data – ACX (I-P)

Unit Size (Tons)		140	160	180	200	215	230
Refrigerant		R-454B					
Compressor Model							
Quantity	#	4	4	6	6	6	6
Tonnage/ckt ^(a)		30+40	40+40	30+30+30	30+30+40	40+40+30	40+40+40
Evaporator							
Water storage	gal	17.4	17.4	17.4	17.4	17.4	21.6
Water storage - Ice Making	gal	14	14	14	14	14	14
Min. flow ^(b)	gpm	168	192	216	240	258	276
Max. flow ^(b)	gpm	504	576	648	720	774	828
Water connection	in.	4	4	4	4	4	4
Max. Water Temperature	°F	150	150	150	150	150	150
Min. Water Pressure	psig	0	0	0	0	0	0
Max. Water Pressure	psig	150	150	150	150	150	150
Condenser							
Quantity of coils	#	8	8	10	10	12	12
Coil length	in.	83.6	83.6	83.6	83.6	83.6	83.6
Coil height	in.	49.2	49.2	49.2	49.2	49.2	49.2
Coil width	in.	3.4	3.4	3.4	3.4	3.4	3.4
Fins per foot	f _{pf}	180	180	180	180	180	180
Fans							
Quantity	#	8	8	10	10	12	12
Diameter	in.	37.5	37.5	37.5	37.5	37.5	37.5
Airflow per fan - cooling mode	cfm	12288	12288	12288	12288	12288	12288
Airflow per fan - heating mode	cfm	10510	10510	10510	10510	10510	10510
Power per motor cooling mode	HP	1.7	1.7	1.7	1.7	1.7	1.7
Power per motor heating mode	HP	1.5	1.5	1.5	1.5	1.5	1.5
Motor RPM - cooling mode	rpm	820	820	820	820	820	820
Motor RPM - heating mode	rpm	740	740	740	740	740	740
Tip speed cooling mode	ft/min	7728	7728	7728	7728	7728	7728
Tip speed heating mode	ft/min	6785	6785	6785	6785	6785	6785
General Unit							
Capacity steps	%	21-43-71-100	25-50-75-100	17-33-50-67-83-100	15-30-50-65-80-100	14-32-50-64-82-100	17-33-50-67-83-100
Min. ambient - heating mode	°F	0	0	0	0	0	0

Table 3. General data – ACX (I-P) (continued)

Unit Size (Tons)		140	160	180	200	215	230
Max. ambient - heating mode	°F	95	95	95	95	95	95
Min. ambient - cooling mode	°F	-4	-4	-4	-4	-4	-4
Max. ambient - cooling mode	°F	125	125	125	125	125	125
Refrigerant charge/ckt							
R-454B ^(a)	lb	121	121	163	163	187	189
Oil charge/ckt ^(a)	gal	5.1	5.1	7	7	7	7

^(a) Data shown for one circuit only. The second circuit always matches.

^(b) Minimum and maximum flow rates apply to constant-flow chilled water system running at AHRI conditions, without freeze inhibitors added to the water loop.

Table 4. General data - ACX (SI)

Unit Size (Tons)		140	160	180	200	215	230
Refrigerant		R-454B					
Compressor Model							
Quantity	#	4	4	6	6	6	6
Tonnage/ckt ^(a)		30+40	40+40	30+30+30	30+30+40	40+40+30	40+40+40
Evaporator							
Water storage	l	65.9	65.9	65.9	65.9	65.9	81.8
Water storage - Ice Making	l	53	53	53	53	53	53
Min. flow ^(b)	l/s	10.6	12.1	13.6	15.1	16.3	17.4
Max. flow ^(b)	l/s	31.8	36.3	40.9	45.4	48.8	52.2
Water connection	mm	101.6	101.6	101.6	101.6	101.6	101.6
Max. Water Temperature	°C	65.5	65.5	65.5	65.5	65.5	65.5
Min. Water Pressure	kPa	0	0	0	0	0	0
Max. Water Pressure	kPa	1034.2	1034.2	1034.2	1034.2	1034.2	1034.2
Condenser							
Quantity of coils	#	8	8	10	10	12	12
Coil length	mm	2123	2123	2123	2123	2123	2123
Coil height	mm	1250	1250	1250	1250	1250	1250
Coil width	mm	86	86	86	86	86	86
Fins per foot	fpf	180	180	180	180	180	180
Fans							
Quantity	#	8	8	10	10	12	12
Diameter	mm	953	953	953	953	953	953
Airflow per fan - cooling mode	m ³ /h	20877	20877	20877	20877	20877	20877
Airflow per fan - heating mode	m ³ /h	17856	17856	17856	17856	17856	17856
Power per motor cooling mode	kW	1.3	1.3	1.3	1.3	1.3	1.3
Power per motor heating mode	kW	1.1	1.1	1.1	1.1	1.1	1.1
Motor RPM - cooling mode	rpm	820	820	820	820	820	820
Motor RPM - heating mode	rpm	740	740	740	740	740	740
Tip speed cooling mode	m/s	39.3	39.3	39.3	39.3	39.3	39.3
Tip speed heating mode	m/s	34.5	34.5	34.5	34.5	34.5	34.5
General Unit							
Refrigerant circuits	#	2	2	2	2	2	2
Capacity steps	%	21-43-71-100	25-50-75-100	17-33-50-67-83-100	15-30-50-65-80-100	14-32-50-64-82-100	17-33-50-67-83-100



General Information

Table 4. General data - ACX (SI) (continued)

Unit Size (Tons)		140	160	180	200	215	230
Min. ambient - heating mode	°C	-18	-18	-18	-18	-18	-18
Max. ambient - heating mode	°C	35	35	35	35	35	35
Min. ambient - cooling mode	°C	-20	-20	-20	-20	-20	-20
Max. ambient - cooling mode	°C	52	52	52	52	52	52
Refrig charge/ckt							
R-454B ^(a)	kg	55	55	74	74	85	86
Oil charge/ckt ^(a)	l	19.3	19.3	26.5	26.5	26.5	26.5

^(a) Data shown for one circuit only. The second circuit always matches.

^(b) Minimum and maximum flow rates apply to constant-flow chilled water system running at AHRI conditions, without freeze inhibitors added to the water loop.



Pre-Installation

Unit Inspection

To protect against loss due to damage incurred in transit, perform inspection immediately upon receipt of the unit.

Exterior Inspection

If the job site inspection reveals damage or material shortages, file a claim with the carrier immediately. Specify the type and extent of the damage on the bill of lading before signing. Notify the appropriate sales representative.

Important: Do not proceed with installation of a damaged unit without sales representative's approval.

- Visually inspect the complete exterior for signs of shipping damages to unit or packing material.
- Verify that the unit is properly equipped and there are no material shortages.

Note: Corrosion due to dirt, road grime, road salt, and other contaminants picked up during shipping is not the responsibility of the carrier.

Inspection for Concealed Damage

Visually inspect the components for concealed damage as soon as possible after delivery and before it is stored.

If concealed damage is discovered:

- Notify the carrier's terminal of the damage immediately by phone and by mail.
- Concealed damage must be reported within 15 days.
- Request an immediate, joint inspection of the damage with the carrier and consignee.
- Stop unpacking the unit.
- Do not remove damaged material from receiving location.

- Take photos of the damage, if possible.
- The owner must provide reasonable evidence that the damage did not occur after delivery.

Repair

Notify the appropriate sales representative before arranging unit installation or repair.

Important: Do not repair unit until the damage has been inspected by the carrier's representative.

Unit Storage

If the chiller is to be stored in ambients of 32°F or less, evaporator should be blown out to remove any liquid and refrigerant isolation valves should be closed. If the chiller is to be stored for more than one month prior to installation, observe the following precautions:

- Do not remove the protective coverings from the electrical panel.
- Store the chiller in a secure area.
- Units charged with refrigerant should not be stored where temperatures exceed 155°F.
- At least every three months, attach a gauge and manually check the pressure in the refrigerant circuit. If the refrigerant pressure is below 200 psig at 70°F (or 145 psig at 50°F), call a qualified service organization and the appropriate Trane sales office.

Note: Pressure will be approximately 20 psig if shipped with the optional nitrogen charge.



Pre-Installation

Installation Requirements

Type	Trane Supplied Trane Installed	Trane Supplied Field Installed	Field Supplied Field Installed
Foundation			<ul style="list-style-type: none"> • Meet foundation requirements
Rigging			<ul style="list-style-type: none"> • Safety chains • Clevis connectors • Lifting beam
Isolation		Elastomeric isolators (optional)	<ul style="list-style-type: none"> • Elastomeric isolators (optional)
Electrical	<ul style="list-style-type: none"> • Circuit breakers (optional) • Unit Mounted Starter 		<ul style="list-style-type: none"> • Circuit breakers (optional) • Electrical connections to unit mounted starter • Wiring sizes per submittal and NEC • Terminal lugs • Ground connection(s) • BAS wiring (optional) • Control voltage wiring • Chilled water pump contactor and wiring including interlock • Option relays and wiring • Air-Fi module (Optional) • Wi-Fi antenna (Optional) • LTE modem (Optional) • Energy meter (Optional)
Water piping	<ul style="list-style-type: none"> • Flow switch • Water strainer 		<ul style="list-style-type: none"> • Taps for thermometers and gauges • Thermometers • Water flow pressure gauges • Isolation and balancing valves in water piping • Vents and drain • Waterside pressure relief valves
Insulation	<ul style="list-style-type: none"> • Insulation • High humidity insulation (opt) 		Insulation
Water Piping Connection Components	Grooved pipe		
Other Materials	<ul style="list-style-type: none"> • R-454B refrigerant (1 lb max per unit as needed) • Dry nitrogen (20 psig max per unit as needed) 		
Ascend™ Air-Cooled Chiller Models ACS and ACX Installation Completion and Request for Trane Service Form (AC-ADF007*-EN) See Log and Check Sheet chapter			
Chiller Start-up Commissioning	Trane, or an agent of Trane specifically authorized to perform start-up of Trane® products		



Dimensions and Weights

Unit Dimensions

Standard Unit

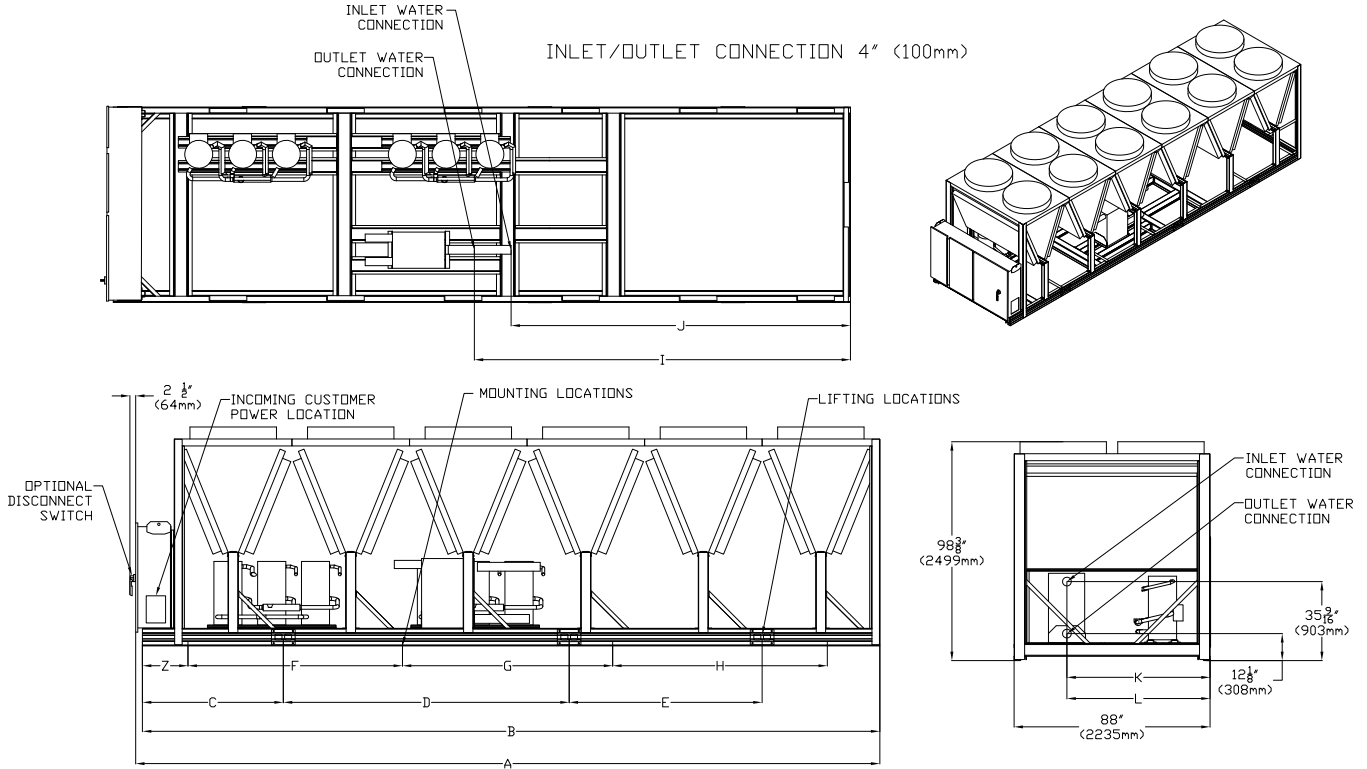

Dim	Unit Size											
	140		160		180		200		215		230	
	in	mm	in	mm	in	mm	in	mm	in	mm	in	mm
A	228.8	5810	228.8	5810	281.6	7153	281.6	7153	334.4	8494	334.4	8494
B	225.8	5734	225.8	5734	278.6	7075	278.6	7075	331.4	8418	331.4	8418
C	48.3	1227	48.3	1227	63.3	1608	63.3	1608	63.3	1608	63.3	1608
D	124.3	3158	124.3	3158	162.1	4116	162.1	4116	128.5	3264	128.5	3264
E	-	-	-	-	-	-	-	-	86.8	2203	86.8	2203
Z	20.4	519	20.4	519	40.1	1019	40.1	1019	40.1	1019	40.1	1019
F	55.1	1400	55.1	1400	76.8	1949	76.8	1949	76.8	1949	76.8	1949
G	59.1	1500	59.1	1500	59.1	1500	59.1	1500	94.5	2400	94.5	2400
H	55.1	1400	55.1	1400	70.9	1800	70.9	1800	96.4	2450	96.4	2450
I	68.8	1748	68.8	1748	104.6	2656	104.6	2656	157.4	3997	157.4	3997
J (ACSA)	64.0	1626	64.0	1626	99.8	2534	99.8	2534	152.6	3875	152.6	3875
J (ACXA)	57.9	1471	57.9	1471	93.7	2380	93.7	2380	146.5	3721	146.5	3721
K	64.3	1633	64.3	1633	64.3	1633	64.3	1633	64.3	1633	64.3	1633
L	64.3	1633	64.3	1633	64.3	1633	64.3	1633	64.3	1633	64.3	1633



Dimensions and Weights

Units with Pump Package Option

INLET/OUTLET CONNECTION 4" (100mm)

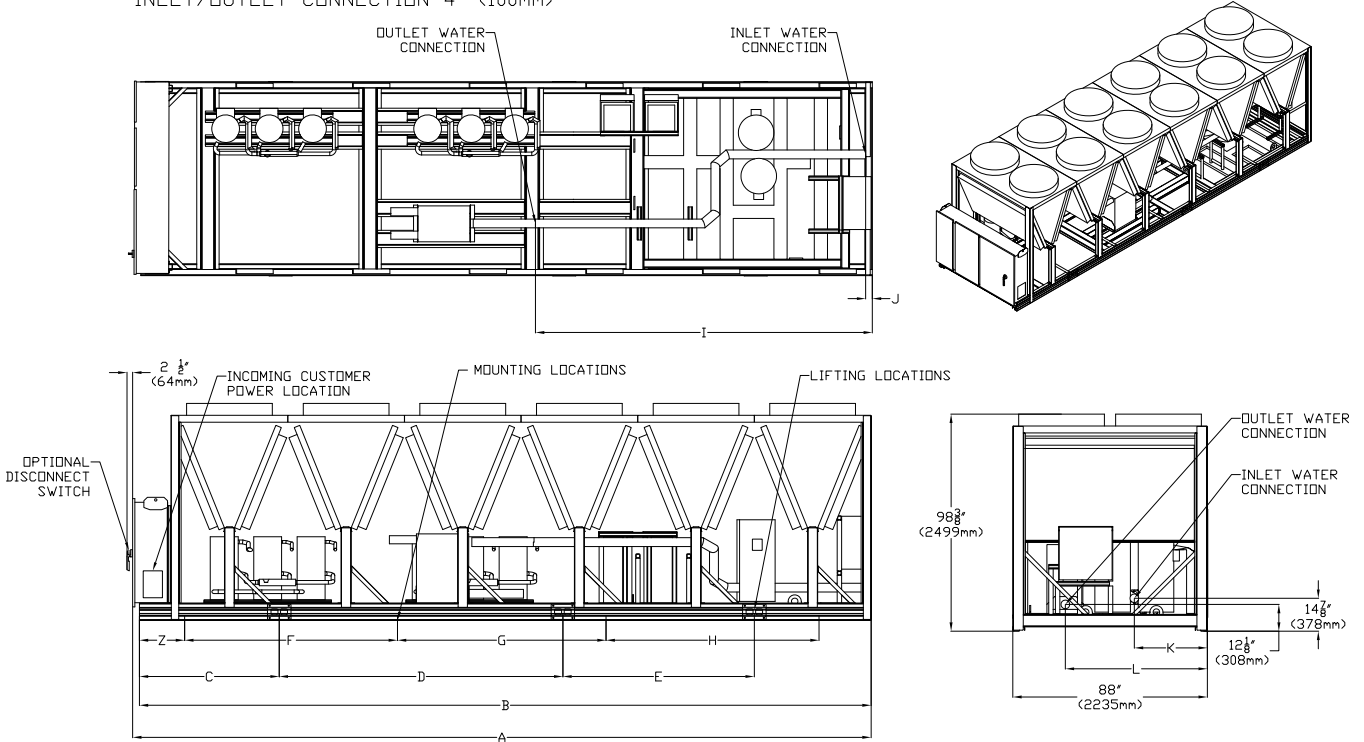

Dim	Unit Size											
	140		160		180		200		215		230	
	in	mm	in	mm	in	mm	in	mm	in	mm	in	mm
A	228.8	5810	228.8	5810	281.6	7153	281.6	7153	334.4	8494	334.4	8494
B	225.8	5734	225.8	5734	278.6	7075	278.6	7075	331.4	8418	331.4	8418
C	48.3	1227	48.3	1227	63.3	1608	63.3	1608	63.3	1608	63.3	1608
D	124.3	3158	124.3	3158	162.1	4116	162.1	4116	128.5	3264	128.5	3264
E	-	-	-	-	-	-	-	-	86.8	2203	86.8	2203
Z	20.4	519	20.4	519	40.1	1019	40.1	1019	40.1	1019	40.1	1019
F	55.1	1400	55.1	1400	76.8	1949	76.8	1949	76.8	1949	76.8	1949
G	59.1	1500	59.1	1500	59.1	1500	59.1	1500	94.5	2400	94.5	2400
H	55.1	1400	55.1	1400	70.9	1800	70.9	1800	96.4	2450	96.4	2450
I	39.6	1006	39.6	1006	100.1	2542	100.1	2542	152.9	3883	152.9	3883
J	5.3	134	5.3	134	3.2	81	3.2	81	3.2	81	3.2	81
K	32.8	832	32.8	832	33.0	838	33.0	838	33.0	838	33.0	838
L	75.4	1915	75.4	1915	64.3	1632	64.3	1632	64.3	1633	64.3	1633

Service Clearance

Figure 2. Unit service clearance requirements

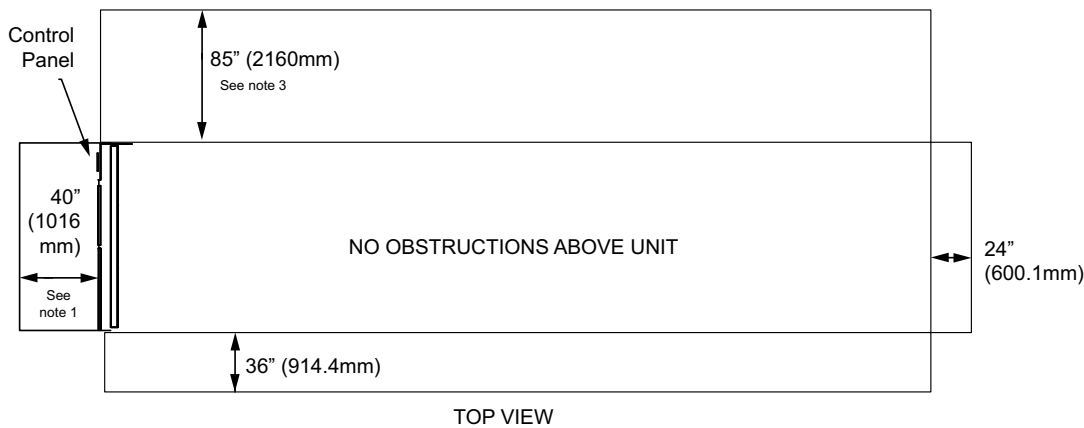

Notes:

1. A full 40 inch clearance is required in front of the control panel. Must be measured from front of panel, not end of unit base. Installer must also follow NEC and local/state codes for electrical clearance requirements.
2. Area above unit is required for operation, maintenance, access panel and air flow. No obstructions above unit.
3. Clearance of 85 inch on the side of the unit is required for coil replacement. Preferred side for coil replacement is shown (left side of the unit, as facing control panel), however either side is acceptable.
4. For obstructions or multiple units, refer to *Close-Spacing and Restricted Airflow Situations Engineering Bulletin (AC-PRB001*-EN)*.



Dimensions and Weights

Weights

Table 5. Unit weights

Unit Size (tons)		Standard Unit				Options - Additional Weight	
		Shipping		Operating		Pump Package	
		lb	kg	lb	kg	lb	kg
ACS	140	7754	3517	7897	3581	2970	1347
	160	7754	3517	7897	3581	2970	1347
	180	9434	4278	9577	4343	3205	1454
	200	9434	4278	9577	4343	3205	1454
	215	10376	4706	10520	4771	3711	1683
	230	10523	4772	10701	4853	3711	1683
ACX	140	9667	4389	9809	4453	2970	1347
	160	9667	4389	9809	4453	2970	1347
	180	11735	5328	11877	5392	3205	1454
	200	11735	5328	11877	5392	3205	1454
	215	13020	5911	13162	5976	3711	1683
	230	13135	5963	13311	6043	3711	1683

Note: Weights include factory charge of refrigerant and oil.



A2L Work Procedures

⚠ WARNING

Risk of Fire — Flammable Refrigerant!

Failure to follow instructions below could result in death or serious injury, and equipment damage.

- To be repaired only by trained service personnel.
- Do not puncture refrigerant tubing.
- Dispose of properly in accordance with federal or local regulations.

⚠ WARNING

Refrigerant under High Pressure!

Failure to follow instructions below could result in an explosion which could result in death or serious injury or equipment damage.

System contains refrigerant under high pressure. Recover refrigerant to relieve pressure before opening the system. See unit nameplate for refrigerant type. Do not use non-approved refrigerants, refrigerant substitutes, or refrigerant additives.

⚠ WARNING

Hazardous Voltage!

Failure to disconnect power before servicing could result in death or serious injury.

Disconnect all electric power, including remote disconnects before servicing. Follow proper lockout/tagout procedures to ensure the power can not be inadvertently energized. Verify that no power is present with a voltmeter.

The units described in this manual use R-454B refrigerant. Use ONLY R-454B rated service equipment or components with these units. For specific handling concerns with R-454B, contact your local Trane representative.

Installation, repair, removal, or disposal should be performed by trained service personnel.

At all times, Trane's maintenance and service guidelines shall be followed. If in doubt, contact Trane technical support for assistance.

Serviceing

Prior to initiating work on equipment, check the area with an appropriate refrigerant detector. Ensure the service personnel are properly trained regarding work in potentially toxic or flammable atmospheres. Ensure that the leak detection equipment being used is suitable for use with all applicable refrigerants, i.e. non-sparking, adequately

sealed, or intrinsically safe. Be aware that the refrigerant does not contain an odor.

If any hot work is to be conducted on the refrigerating equipment or any associated parts, appropriate fire extinguishing equipment shall be available on hand. A dry powder or CO₂ fire extinguisher should be located adjacent to the charging area.

At all times, Trane's maintenance and service guidelines shall be followed. In in doubt, contact Trane technical support for assistance.

All maintenance staff and others working in the local area shall be instructed on the nature of the work being carried out. Work in confined spaces shall be avoided.

Ignition Source Mitigation

Do not use any sources of ignition when working on the refrigeration system.

Keep all ignition sources, including cigarette smoking, away from the site of installation, repair, removal or disposal, during which refrigerant can potentially be released to the surrounding space.

Survey the area around the equipment before initiating work to ensure no flammable hazards or ignition risks are present.

"No Smoking" signs shall be displayed.

Do not use devices that can be a source of ignition to accelerate defrosting of components. Use only defrost and cleaning procedures recommended by Trane. Do not pierce or burn.

Ventilation

Ensure that the area is in the open or that it is adequately ventilated before breaking into the system or conducting any hot work. A degree of ventilation shall continue during the period that the work is carried out. The ventilation should safely disperse any released refrigerant and preferably expel it externally into the atmosphere. If present, check that the ventilation system, including outlets, are operating adequately and are not obstructed.

Refrigerating Equipment

Refrigerant piping or components should not be installed in locations where substances which may corrode them are present.

Check that equipment hazard markings are visible and legible. Replace them if they are not.

For equipment using secondary fluids, like water or glycol, check that refrigerant is not present in the secondary fluid loop before conducting any hot work.

Electrical Devices

Do not apply power to the circuit if a fault exists which compromises safety. If the fault cannot be corrected



A2L Work Procedures

immediately, but it is necessary to continue operation, an adequate temporary solution shall be used. This shall be reported to the owner of the equipment, so all parties are advised.

Initial safety checks shall include:

- Cabling is not subject to wear, corrosion, excessive pressure, vibration, sharp edges, or any other adverse environmental effects. Account for the effects of aging or continual vibration from sources such as compressors or fans.
- Capacitors are discharged. This shall be done in a safe manner to avoid possibility of sparking.
- No live electrical components and wiring are exposed while charging, recovering, or purging the system.
- Verify continuity of earth bonding.
- Replace electrical components with Trane replacement parts, or those meeting the same ratings and qualified for flame arrest protection, UL LZGH2 category.

Leak Detection

Never use an open flame to detect leaks. A halide torch should not be used. Use only approved leak detection methods per this instruction manual.

The following leak detection methods are deemed acceptable for all refrigerant systems.

Electronic leak detectors may be used to detect refrigerant leaks but, in the case of flammable refrigerants, the sensitivity may not be adequate, or may need re-calibration. (Detection equipment shall be calibrated in a refrigerant-free area.) Ensure that the detector is not a potential source of ignition and is suitable for the refrigerant used. Leak detection equipment shall be set at a percentage of the LFL gas (25% maximum) is confirmed.

Leak detection fluids are also suitable for use with most refrigerants but the use of detergents containing chlorine shall be avoided as the chlorine may react with the refrigerant and corrode the copper pipe-work.

Examples of leak detection fluids are:

- Bubble method
- Fluorescent method agents

If a leak is suspected, all naked flames shall be removed/ extinguished.

If a refrigerant leak is found which requires brazing, all refrigerant shall be recovered from the system, or isolated (by means of shut off valves) in a part of the system remote from the leak.

Refrigerant Removal and Evacuation

When breaking into the refrigerant circuit to make repairs – or for any other purpose – conventional procedures shall be used. However, for flammable refrigerants it is important

that best practice be followed, since flammability is a consideration.

The following procedure shall be adhered to:

1. Safely remove refrigerant following local and national regulations.
2. Evacuate.
3. Purge the circuit with inert gas.
4. Evacuate (optional for A2L).
5. Continuously flush or purge with inert gas when using flame to open circuit.
6. Open the circuit.

Prior to refrigerant removal, open all appropriate valves, including solenoid and electronic expansion valves (EXVs). Use control settings, where available. When not available, manually open all electronically controlled valves using acceptable service procedures.

The recovery equipment shall be in good working order with instructions available. Equipment shall be suitable for the recovery of the flammable refrigerant. For specific handling concerns, contact the manufacturer. Ensure all hose connections are checked for tightness to avoid refrigerant leaks.

The refrigerant shall be recovered into the correct recovery cylinders if venting is not allowed by local and national codes. Do not mix refrigerants in recovery unit and especially not in cylinders.

Refrigerant recovery unit should be purged with an inert gas after each use or before using with a different refrigerant Class – for example, A2L to A1.

If compressors or compressor oils are to be removed, ensure that they have been evacuated to an acceptable level to make certain that flammable refrigerant does not remain within the lubricant. The compressor body shall not be heated by an open flame or other ignition sources to accelerate this process. When oil is drained from a system, it shall be carried out safely.

The system shall be purged with oxygen-free nitrogen to render the appliance safe for flammable refrigerants. This process might need to be repeated several times. Compressed air or oxygen shall not be used for purging refrigerant systems.

The system shall be vented down to atmospheric pressure to enable work to take place.

The outlet for the vacuum pump shall not be close to any potential ignition sources, and ventilation shall be available.

Refrigerant Charging

In addition to conventional charging procedures, the following requirements shall be followed.

- Ensure that contamination of different refrigerants does not occur when using charging equipment.
- Hoses or lines shall be as short as possible to minimize the amount of refrigerant contained in them.

- Cylinders shall be kept in an appropriate position according to the instructions.
- Ensure that the refrigerating system is earthed prior to charging the system with refrigerant.
- Label the system when charging is complete (if not already).
- Extreme care shall be taken not to overfill the refrigerating system.

Prior to recharging the system, it shall be pressure-tested with the appropriate purging gas. The system shall be leak-tested on completion of charging but prior to commissioning. A follow up leak test shall be carried out prior to leaving the site.

Prior to refrigerant charging, open all appropriate valves, including solenoid and electronic expansion valves (EXVs). Use control settings, where available. When not available, manually open all electronically controlled valves using acceptable service procedures.

Decommissioning

Before carrying out the decommissioning procedure, it is essential that the trained service personnel is completely familiar with the equipment and all its details. It is recommended good practice that all refrigerants are recovered safely. Prior to the task being carried out, an oil and refrigerant sample shall be taken in case analysis is required prior to re-use of recovered refrigerant. It is essential that electrical power is available before the task is commenced.

1. Become familiar with the equipment and its operation.
2. Isolate system electrically.
3. Before attempting the procedure, ensure that:
 - a. Mechanical handling equipment is available, if required, for handling refrigerant cylinders.
 - b. All personal protective equipment is available and being used correctly.
 - c. The recovery process is supervised at all times by a competent person.
 - d. Recovery equipment and cylinders conform to the appropriate standards.
4. Pump down refrigerant system, if possible.
5. If a vacuum is not possible, make a manifold so that refrigerant can be removed from various parts of the system.
6. Make sure that cylinder is situated on the scales before recovery takes place.
7. Start the recovery machine and operate in accordance with instructions.
8. Do not overfill cylinders (no more than 80% volume liquid charge).
9. Do not exceed the maximum working pressure of the cylinder, even temporarily.
10. When the cylinders have been filled correctly and the process completed, make sure that the cylinders and the equipment are removed from site promptly and all isolation valves on the equipment are closed off.
11. Recovered refrigerant shall not be charged into another refrigerating system unless it has been cleaned and checked. When equipment has been decommissioned, attach a signed label which includes the date of decommissioning.
12. When equipment has been decommissioned, attach a signed label which includes the date of decommissioning.



Installation - Mechanical

Location Requirements

Sound Considerations

- Locate the unit away from sound-sensitive areas.
- Install the optional elastomeric isolators under the unit. See Isolation and Sound Emission section.
- Chilled water piping should not be supported by chiller frame.
- Install rubber vibration isolators in all water piping.
- Use flexible electrical conduit.
- Seal all wall penetrations.

Note: Consult an acoustical engineer for critical applications.

Foundation

Provide rigid, non-warping mounting pads or a concrete foundation of sufficient strength and mass to support the applicable operating weight (i.e. including completed piping, and full operating charges of refrigerant, oil and water). The expectation for our equipment is that attached piping is fully supported by an independent structure/system, without being connected to the braze plate heat exchanger. Once in place, the unit must be level within 1/4-inch (6.4 mm) across the length and width of the unit. Trane is not responsible for equipment problems resulting from an improperly designed or constructed foundation.

See Dimensions and Weights chapter for unit operating weights.

Clearances

Provide enough space around the unit to allow the installation and maintenance personnel unrestricted access to all service points. See submittal drawings for the unit dimensions, to provide sufficient clearance for the opening of control panel doors and unit service. See Dimensions and Weights chapter for minimum clearances. In all cases, local codes which require additional clearances will take precedence over these recommendations.

For close spacing information, see AC-PRB001*-EN.

Lifting and Moving Instructions

⚠ WARNING

Heavy Object!

Failure to follow instructions below could result in unit dropping which could result in death or serious injury, and equipment or property-only damage. Ensure that all the lifting equipment used is properly rated for the weight of the unit being lifted. Each of the cables (chains or slings), hooks, and shackles used to lift the unit must be capable of supporting the entire weight of the unit. Lifting cables (chains or slings) may not be of the same length. Adjust as necessary for even unit lift.

⚠ WARNING

Improper Unit Lift!

Failure to properly lift unit in a LEVEL position could result in unit dropping and possibly crushing operator/technician which could result in death or serious injury, and equipment or property-only damage. Test lift unit approximately 24 inches (61 cm) to verify proper center of gravity lift point. To avoid dropping of unit, reposition lifting point if unit is not level.

NOTICE

Equipment Damage!

Moving the chiller using a fork lift could result in equipment or property-only damage. Do not use a fork lift to move the chiller!

Important:

- See unit nameplate and/or unit submittal for total shipping weight.
- See following figures for unit lifting configuration.
- See Dimensions and Weights chapter, or unit submittal, for lifting point locations.

Figure 3. 4-point lift configuration — 140, 160, 180, 200 ton units

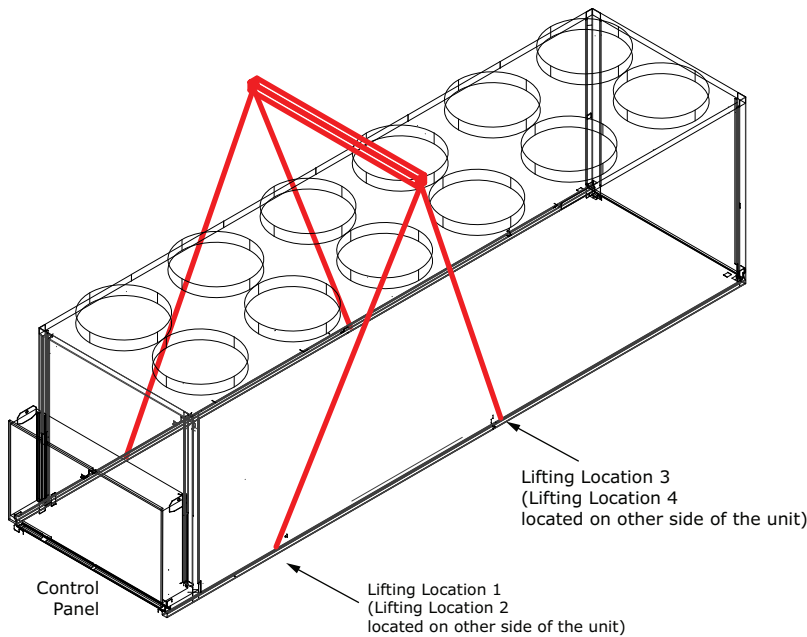
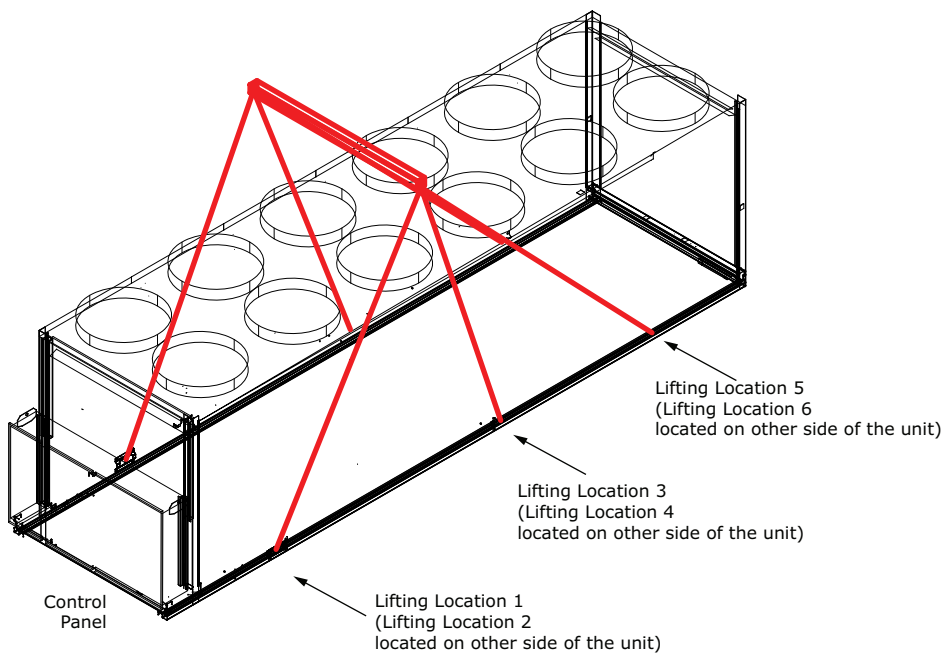

Figure 4. 6-point lift configuration — 215, 230 ton units



Isolation and Sound Emission

The most effective form of isolation is to locate the unit away from any sound sensitive area. Structurally transmitted sound can be reduced by elastomeric vibration eliminators. Spring isolators are not recommended. Consult an acoustical engineer in critical sound applications.

For maximum isolation effect, isolate water lines and electrical conduit. Wall sleeves and rubber isolated piping hangers can be used to reduce the sound transmitted

through water piping. To reduce the sound transmitted through electrical conduit, use flexible electrical conduit.

State and local codes on sound emissions should always be considered. Since the environment in which a sound source is located affects sound pressure, unit placement must be carefully evaluated.

Unit Isolation and Leveling

For additional reduction of sound and vibration, install the optional elastomeric isolators.

Installation - Mechanical

Construct an isolated concrete pad for the unit or provide concrete footings at the unit mounting points. Mount the unit directly to the concrete pads or footings.

Level the unit using the base rail as a reference. The unit must be level within 1/4 inch (6.4 mm) over the entire length and width. Use shims as necessary to level the unit.

Elastomeric Isolators

Note: See unit submittal, or tables in this section, for point weights, isolator locations and isolator selections.

Figure 5. Elastomeric isolator

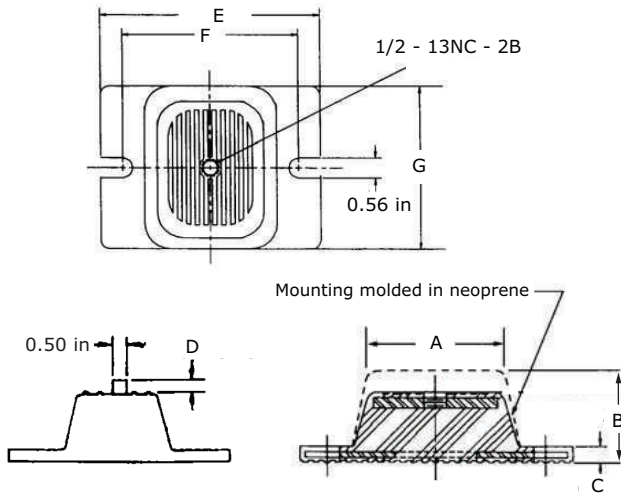

1. Secure the isolators to the mounting surface using the mounting slots in the isolator base plate. Do not fully tighten the isolator mounting bolts at this time.
2. Align the mounting holes in the base of the unit with the threaded positioning pins on the top of the isolators.
3. Lower the unit onto the isolators and secure the isolator to the unit with a nut.
4. Level the unit carefully. Fully tighten the isolator mounting bolts.

Table 6. Elastomeric isolator specifications

Isolator	Max Load (lbs)	Max Deflection (in)	A	B	C	D	E	F	G	Type
Brown 61	1500	0.5	3.0	2.75	0.38	1.60	6.25	5.00	4.63	RDP4-WR
Red 62	2250	0.5	3.0	2.75	0.38	1.60	6.25	5.00	4.63	RDP4-WR
Lime 63	3000	0.5	3.0	2.75	0.38	1.60	6.25	5.00	4.63	RDP4-WR

Mounting Locations, Weights, Isolators

See figure below for mounting point location designations.

Figure 6. Mounting point locations (top view)

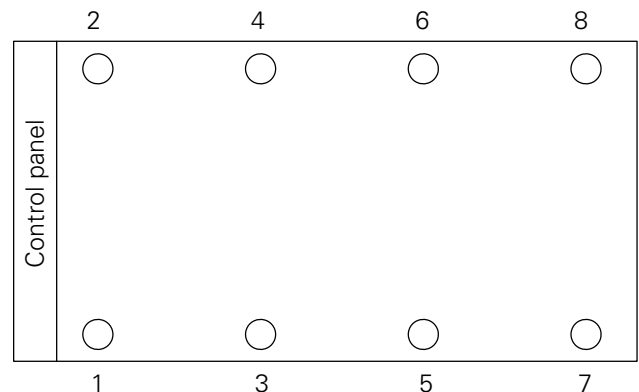

Note: Quantity of isolators varies with unit. See submittal for actual number required for specific unit.

Point Weights

Table 7. Point weights (lb) - base unit (without pump package)

Unit Size		Location							
		1	2	3	4	5	6	7	8
ACS	140	1329	1410	1170	1369	684	671	601	663
	160	1329	1410	1170	1369	684	671	601	663
	180	1645	1832	1365	1717	798	812	663	745
	200	1645	1832	1365	1717	798	812	663	745
	215	1710	1934	1562	1964	911	928	721	790
	230	1745	1945	1611	1983	942	937	741	797
ACX	140	1642	1618	1498	1612	918	824	850	847
	160	1642	1618	1498	1612	918	824	850	847
	180	2369	2432	1889	1976	839	874	742	755
	200	2369	2432	1889	1976	839	874	742	755
	215	2447	2507	2185	2260	1019	1027	880	837
	230	2476	2517	2231	2277	1042	1035	892	841

Table 8. Point weights (lb) - unit with pump package

Unit Size		Location							
		1	2	3	4	5	6	7	8
ACS	140	1317	1277	1283	1487	1289	1322	1336	1554
	160	1317	1277	1283	1487	1289	1322	1336	1554
	180	1663	1696	1481	1897	1403	1548	1351	1742
	200	1663	1696	1481	1897	1403	1548	1351	1742
	215	1774	1869	1697	2145	1607	1772	1486	1880
	230	1810	1881	1741	2163	1644	1784	1503	1886
ACX	140	1671	1532	1578	1698	1539	1474	1562	1725
	160	1671	1532	1578	1698	1539	1474	1562	1725
	180	2422	2334	1999	2111	1417	1612	1431	1757
	200	2422	2334	1999	2111	1417	1612	1431	1757
	215	2549	2482	2307	2405	1694	1880	1640	1915
	230	2578	2493	2350	2420	1722	1890	1650	1918

Isolator Selections

Table 9. Elastomeric isolator selections - base unit (without pump package)

Unit Size		Location							
		1	2	3	4	5	6	7	8
ACS	140	Red 62	Lime 63	Red 62	Lime 63	Brown 61	Brown 61	Brown 61	Brown 61
	160	Red 62	Lime 63	Red 62	Lime 63	Brown 61	Brown 61	Brown 61	Brown 61
	180	Red 62	Lime 63	Red 62	Lime 63	Brown 61	Brown 61	Brown 61	Brown 61
	200	Red 62	Lime 63	Red 62	Lime 63	Brown 61	Brown 61	Brown 61	Brown 61
	215	Red 62	Lime 63	Red 62	Lime 63	Brown 61	Brown 61	Brown 61	Brown 61
	230	Red 62	Lime 63	Red 62	Lime 63	Brown 61	Brown 61	Brown 61	Brown 61



Installation - Mechanical

Table 9. Elastomeric isolator selections - base unit (without pump package) (continued)

ACX	140	Red 62	Lime 63	Red 62	Lime 63	Brown 61	Brown 61	Brown 61	Brown 61
	160	Red 62	Lime 63	Red 62	Lime 63	Brown 61	Brown 61	Brown 61	Brown 61
	180	Lime 63	Lime 63	Lime 63	Lime 63	Brown 61	Brown 61	Brown 61	Brown 61
	200	Lime 63	Lime 63	Lime 63	Lime 63	Brown 61	Brown 61	Brown 61	Brown 61
	215	Lime 63	Lime 63	Lime 63	Lime 63	Brown 61	Brown 61	Brown 61	Brown 61
	230	Lime 63	Lime 63	Lime 63	Lime 63	Brown 61	Brown 61	Brown 61	Brown 61

Table 10. Elastomeric isolator selections - unit with pump package

Unit Size		Location							
		1	2	3	4	5	6	7	8
ACS	140	Red 62	Lime 63	Red 62	Lime 63	Red 62	Red 62	Red 62	Red 62
	160	Red 62	Lime 63	Red 62	Lime 63	Red 62	Red 62	Red 62	Red 62
	180	Red 62	Lime 63	Red 62	Lime 63	Red 62	Red 62	Red 62	Red 62
	200	Red 62	Lime 63	Red 62	Lime 63	Red 62	Red 62	Red 62	Red 62
	215	Red 62	Lime 63	Red 62	Lime 63	Red 62	Red 62	Red 62	Red 62
	230	Red 62	Lime 63	Red 62	Lime 63	Red 62	Red 62	Red 62	Red 62
ACX	140	Red 62	Lime 63	Red 62	Lime 63	Red 62	Red 62	Red 62	Red 62
	160	Red 62	Lime 63	Red 62	Lime 63	Red 62	Red 62	Red 62	Red 62
	180	Lime 63	Lime 63	Lime 63	Lime 63	Red 62	Red 62	Red 62	Red 62
	200	Lime 63	Lime 63	Lime 63	Lime 63	Red 62	Red 62	Red 62	Red 62
	215	Lime 63	Lime 63	Lime 63	Lime 63	Red 62	Red 62	Red 62	Red 62
	230	Lime 63	Lime 63	Lime 63	Lime 63	Red 62	Red 62	Red 62	Red 62

Evaporator Piping

NOTICE

Proper Water Treatment Required!

The use of untreated or improperly treated water could result in scaling, erosion, corrosion, algae or slime.

Use the services of a qualified water treatment specialist to determine what water treatment, if any, is required. Trane assumes no responsibility for equipment failures which result from untreated or improperly treated water, or saline or brackish water.

NOTICE

Heat Exchanger Damage!

Failure to follow instructions below could result in heat exchanger damage.

If an acidic commercial flushing solution is used, bypass the EVP chiller to prevent damage .

- Evaporator water connections are grooved.
- Thoroughly flush all water piping to the unit before making the final piping connections to the unit.
- Components and layout will vary slightly, depending on the location of connections and the water source.

- A vent is provided at the chilled water inlet line to the evaporator. Additional vents at high points in the piping must be provided to bleed air from the chilled water system.
- Install necessary pressure gauges to monitor the entering and leaving chilled water pressures.
- Provide shutoff valves in lines to the gauges to isolate them from the system when they are not in use.
- Use rubber vibration eliminators to prevent vibration transmission through the water lines.
- If desired, install thermometers in the lines to monitor entering and leaving water temperatures.
- Install a balancing valve in the leaving water line to control water flow balance.
- Install shutoff valves on both the entering and leaving water lines so that the evaporator can be isolated for service.

Evaporator Piping Components

Piping components include all devices and controls used to provide proper water system operation and unit operating safety. These components and their general locations are given below.

Figure 7. Typical water piping components

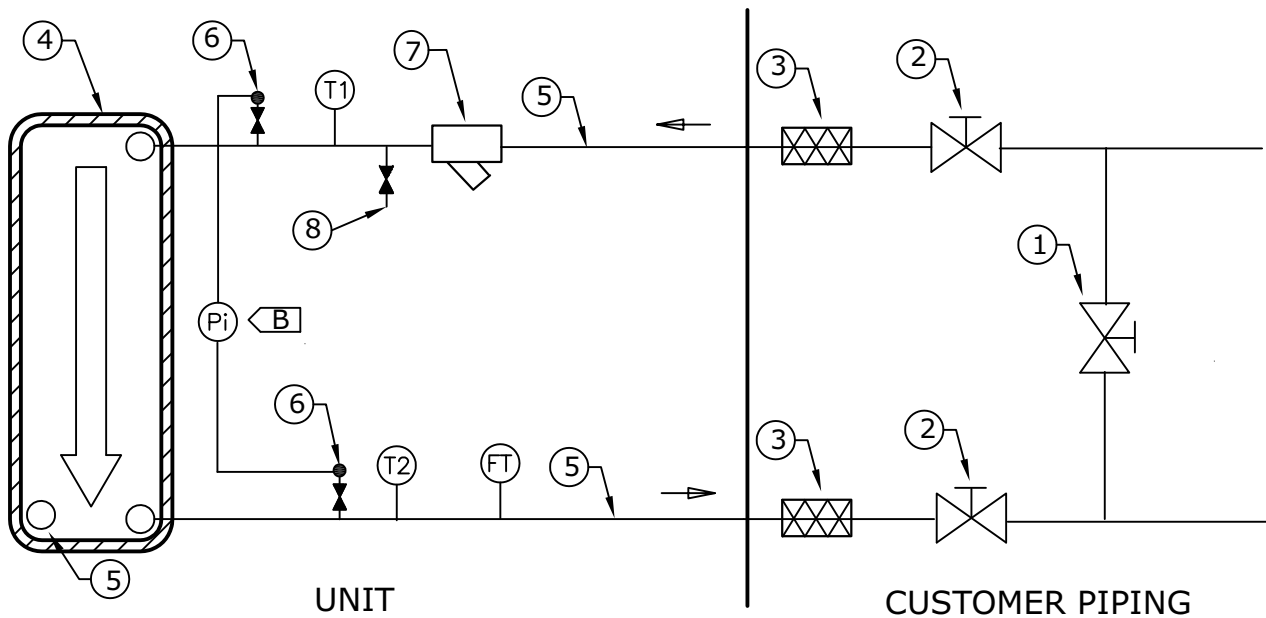

Item	Description	Item	Description
1	Bypass Valve	Pi	Pressure Gauge
2	Isolation Valve	FT	Water Flow Switch (Factory Installed)
3	Vibration Eliminator	T1	Evaporator Water Inlet Temperature Sensor
4	Evaporator Heat Exchanger	T2	Evaporator Water Outlet Temperature Sensor
5	Heaters	NOTE	
6	Valve for Pressure point	B	Brazed plate differential pressure gauge and piping not supplied. Must account for water head height difference when calculating brazed plate pressure differential.
7	Strainer		
8	Piping Heater		

Entering Chilled Water Piping

- Air vents (to bleed air from system).
- Water pressure gauges with shutoff valves.
- Vibration eliminators.
- Shutoff (isolation) valves.
- Thermometers (if desired).
- Relief valve.

Leaving Chilled Water Piping

- Air vents (to bleed air from system).
- Water pressure gauges with shutoff valves.

- Vibration eliminators.
- Shutoff (isolation) valves.
- Thermometers.
- Balancing valve.

Water Strainer

The water strainer is factory-installed with taps for the pressure gauges on the inlet and outlet. Install pressure gauges in order to measure differential pressure across the filter. This will help to determine when it is necessary to clean the water strainer

Evaporator Flow Switch
NOTICE
Flow Switch Damage!

Incorrect voltage application could cause damage to the flow switch.

Flow switch is on a 24V circuit. Do NOT apply 120V to the flow switch.

The flow switch is factory-installed and programmed based on the operating conditions submitted with the order. The leaving evaporator temperature, fluid type and fluid concentration affect the selected flow switch. If the operating conditions on the job site change, the flow switch may need to be replaced. Contact your local Trane Sales office for more information.

The sensor head includes 3 LEDs, two yellow and one green. Wait 15 seconds after power is applied to the sensor before evaluating LEDs for flow status. When wired correctly and flow is established, only the green LED should be lit. Following are the LED indicators:

- Green ON, both yellow OFF — Flow
- Green and outside yellow ON — No Flow
- Center yellow ON continuously — Miswire

Indexing Flow Switch

To properly index the flow switch, the following requirements must be met:

- The dot must be at a position no greater than 90° off Index.
- The torque must be between 22 ft-lb minimum and 74 ft-lb maximum.
- A minimum distance of 5x pipe diameter must be maintained between flow switch and any bends, valves, changes in cross sections, etc.

Figure 8. Proper flow switch indexing

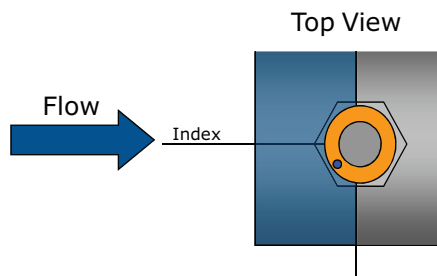

The flow switch must have the dot in the shaded area to the left of this line for proper indexing ($\pm 90^\circ$ off Index).

Evaporator Label

The brazed plate heat exchanger (BPHE) label, including barcode, is located under the insulation, in the locations shown below. Insulation backing over this area has not been removed, so it can be rolled back to access the label.

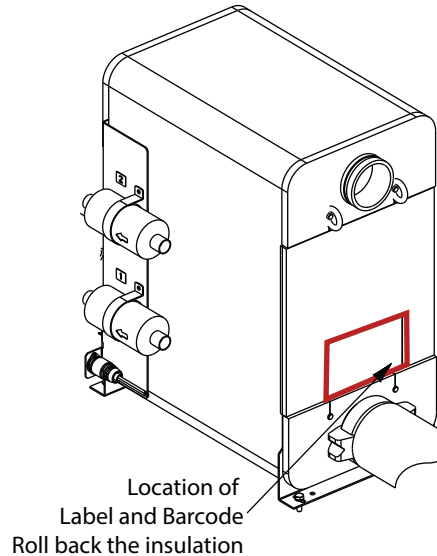

Evaporator Head Loss

Evaporator head loss illustrated in this graph is for water applications. Use Trane Select Assist to determine evaporator head loss of applications with freeze avoidance solutions.

Reference the General Data tables to determine the maximum and minimum evaporator flow limits of each nominal chiller size.

Figure 9. Evaporator head loss

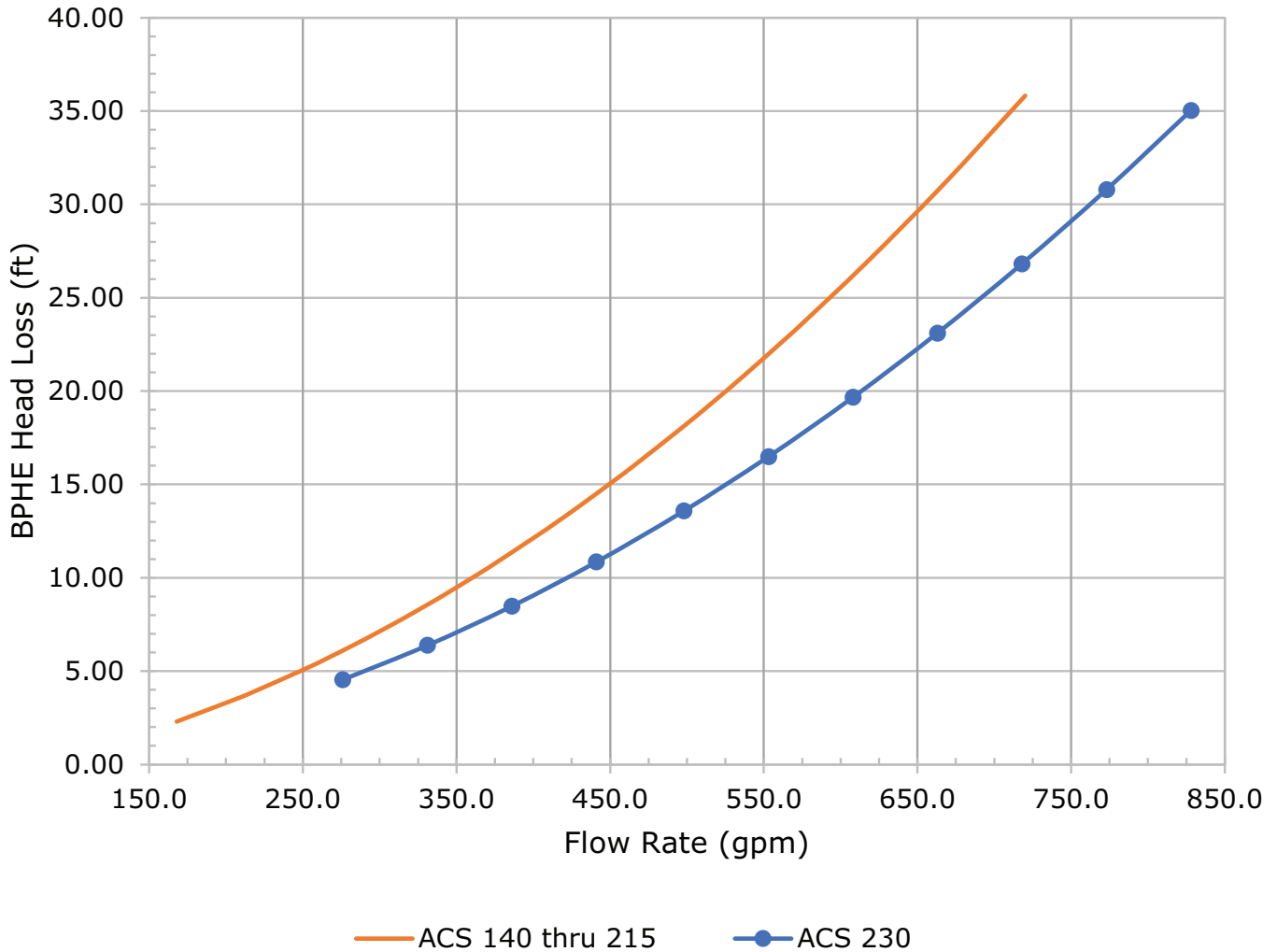



Installation - Mechanical

Freeze Avoidance

One or more of the ambient freeze avoidance methods in the table below must be used to protect the chiller from ambient freeze damage. See RF-PRB002*-EN for more information.

Note: Ascend™ model ACS chillers use brazed plate heat exchangers which are NOT at risk for refrigerant migration freeze. Chiller must only be protected from freeze due to low ambient conditions.

Method	Protects to ambient temperature	Notes
Water Pump Control	Down to 0°F	<ul style="list-style-type: none"> Unit controller can start the pump when the ambient temperatures drops to prevent freezing. For this option the pump must to be controlled by the chiller unand this function must be validated. Heaters are factory-installed on the evaporator and water piping and will protect them from freezing. If dual high head pump package option is selected, the chiller MUST control the pumps.
Heaters	Down to -20°F	<ul style="list-style-type: none"> Freeze protection heaters are provided on all chillers as standard. Heaters are factory-installed on the evaporator and water piping and will protect them from freezing in ambient temperatures down to -20°F (-29°C). Note: For units with optional pump package, heaters will protect to -4°F (-20°C) for water, -20°F (-29°C) for ethylene glycol or propylene glycol Install heat tape on all water piping, pumps, and other components that may be damaged if exposed to freezing temperatures. Heat tape must be designed for low ambient temperature applications. Heat tape selection should be based on the lowest expected ambient temperature. See NOTICE below for important information.
Freeze Inhibitor	Varies. See Low Evaporator Refrigerant Cutout, Glycol Requirements.	<ul style="list-style-type: none"> Freeze protection can be accomplished by adding sufficient glycol to protect against freezing below the lowest ambient expected.
Drain Water Circuit	Below -20°F	<ul style="list-style-type: none"> Shut off the power supply to the unit and to all heaters. Purge the water circuit. Blow out the evaporator to ensure no liquid is left in the evaporator.

NOTICE

Equipment Damage!

Failure to follow these instructions could result in equipment damage.

All heaters have separate power from the unit. All heaters must be energized or the unit controller must control the pumps when the unit is off (unless the water circuit is drained or sufficient glycol is used). In the event of prolonged power loss, neither heaters nor unit control of the pumps will protect the evaporator from catastrophic damage. In order to provide freeze protection in the event of a power loss you MUST drain the evaporator, use sufficient freeze inhibitor in the evaporator or provide back-up power for pump and/or heaters.

Low Evaporator Refrigerant Cutout, Percent Glycol Requirements

The table below shows the low evaporator temperature cutout for different glycol levels. Additional glycol beyond the recommendations will adversely effect unit performance. The unit efficiency will be reduced and the

saturated evaporator temperature will be reduced. For some operating conditions this effect can be significant.

If additional glycol is required, use the actual percent glycol to determine the low refrigerant cutout setpoint.

Note: Table below is not a substitute for full unit simulation for proper prediction of unit performance for specific operating conditions. For information on specific conditions, contact Trane product support.

Table 11. Low evaporator refrigerant temperature cutout (LERTC) and low water temperature cutout (LWTC) — ethylene glycol

Glycol Percentage (%)	Solution Freeze Point (°F)	Minimum Recommended LERTC (°F)	Minimum Recommended LWTC (°F)	Minimum Chilled Water Set Point (°F)
0	32.0	26.0	36.0	41.7
1	31.6	25.6	35.6	41.3
2	31.0	25.0	35.0	40.7
3	30.3	24.3	34.3	40.0
4	29.7	23.7	33.7	39.4
5	29.0	23.0	33.0	38.7
6	28.3	22.3	32.3	38.0
7	27.6	21.6	31.6	37.3
8	26.9	20.9	30.9	36.6
9	26.2	20.2	30.2	35.9
10	25.5	19.5	29.5	35.2
11	24.7	18.7	28.7	34.4
12	23.9	17.9	27.9	33.6
13	23.1	17.1	27.1	32.8
14	22.3	16.3	26.3	32.0
15	21.5	15.5	25.5	31.2
16	20.6	14.6	24.6	30.3
17	19.7	13.7	23.7	29.4
18	18.7	12.7	22.7	28.4
19	17.8	11.8	21.8	27.5
20	16.8	10.8	20.8	26.5
21	15.8	9.8	19.8	25.5
22	14.7	8.7	18.7	24.4
23	13.7	7.7	17.7	23.4
24	12.5	6.5	16.5	22.2
25	11.4	5.4	15.4	21.1
26	10.2	4.2	14.2	19.9
27	9.0	3.0	13.0	18.7
28	7.7	1.7	11.7	17.4
29	6.4	0.4	10.4	16.1
30	5.1	-0.9	9.1	14.8
31	3.7	-2.3	7.7	13.4
32	2.3	-3.7	6.3	12.0



Installation - Mechanical

Table 11. Low evaporator refrigerant temperature cutout (LERTC) and low water temperature cutout (LWTC) — ethylene glycol (continued)

Glycol Percentage (%)	Solution Freeze Point (°F)	Minimum Recommended LERTC (°F)	Minimum Recommended LWTC (°F)	Minimum Chilled Water Set Point (°F)
33	0.8	-5.2	4.8	10.5
34	-0.7	-6.7	3.3	9.0
35	-2.3	-8.3	1.7	7.4
36	-3.9	-9.9	0.1	5.8
37	-5.6	-11.6	-1.6	4.1
38	-7.3	-13.3	-3.3	2.4
39	-9.0	-15.0	-5.0	0.7
40	-10.8	-16.8	-6.8	0.0
41	-12.7	-18.7	-7.0	0.0
42	-14.6	-20.6	-7.0	0.0
43	-16.6	-21.0	-7.0	0.0
44	-18.6	-21.0	-7.0	0.0
45	-20.7	-21.0	-7.0	0.0
46	-22.9	-21.0	-7.0	0.0
47	-25.1	-21.0	-7.0	0.0
48	-27.3	-21.0	-7.0	0.0
49	-29.7	-21.0	-7.0	0.0
50	-32.1	-21.0	-7.0	0.0
51	-34.5	-21.0	-7.0	0.0
52	-37.1	-21.0	-7.0	0.0
53	-39.7	-21.0	-7.0	0.0
54	-42.3	-21.0	-7.0	0.0
55	-45.0	-21.0	-7.0	0.0

Table 12. Low evaporator refrigerant temperature cutout (LERTC) and low water temperature cutout (LWTC) — propylene glycol

Glycol Percentage (%)	Solution Freeze Point (°F)	Minimum Recommended LERTC (°F)	Minimum Recommended LWTC (°F)	Minimum Chilled Water Set Point (°F)
0	32.0	26.0	36.0	41.7
1	31.6	25.6	35.6	41.3
2	31.0	25.0	35.0	40.7
3	30.4	24.4	34.4	40.1
4	29.9	23.9	33.9	39.6
5	29.3	23.3	33.3	39.0
6	28.7	22.7	32.7	38.4
7	28.1	22.1	32.1	37.8
8	27.6	21.6	31.6	37.3
9	27.0	21.0	31.0	36.7
10	26.4	20.4	30.4	36.1
11	25.7	19.7	29.7	35.4

Table 12. Low evaporator refrigerant temperature cutout (LERTC) and low water temperature cutout (LWTC) — propylene glycol (continued)

Glycol Percentage (%)	Solution Freeze Point (°F)	Minimum Recommended LERTC (°F)	Minimum Recommended LWTC (°F)	Minimum Chilled Water Set Point (°F)
12	25.1	19.1	29.1	34.8
13	24.4	18.4	28.4	34.1
14	23.8	17.8	27.8	33.5
15	23.1	17.1	27.1	32.8
16	22.4	16.4	26.4	32.1
17	21.6	15.6	25.6	31.3
18	20.9	14.9	24.9	30.6
19	20.1	14.1	24.1	29.8
20	19.3	13.3	23.3	29.0
21	18.4	12.4	22.4	28.1
22	17.6	11.6	21.6	27.3
23	16.7	10.7	20.7	26.4
24	15.7	9.7	19.7	25.4
25	14.8	8.8	18.8	24.5
26	13.8	7.8	17.8	23.5
27	12.7	6.7	16.7	22.4
28	11.6	5.6	15.6	21.3
29	10.5	4.5	14.5	20.2
30	9.3	3.3	13.3	19.0
31	8.1	2.1	12.1	17.8
32	6.8	0.8	10.8	16.5
33	5.5	-0.5	9.5	15.2
34	4.1	-1.9	8.1	13.8
35	2.7	-3.3	6.7	12.4
36	1.3	-4.7	5.3	11.0
37	-0.3	-6.3	3.7	9.4
38	-1.8	-7.8	2.2	7.9
39	-3.5	-9.5	0.5	6.2
40	-5.2	-11.2	-1.2	4.5
41	-6.9	-12.9	-2.9	2.8
42	-8.8	-14.8	-4.8	0.9
43	-10.7	-16.7	-6.7	0.0
44	-12.6	-18.6	-7.0	0.0
45	-14.6	-20.6	-7.0	0.0
46	-16.7	-21.0	-7.0	0.0
47	-18.9	-21.0	-7.0	0.0
48	-21.1	-21.0	-7.0	0.0
49	-23.4	-21.0	-7.0	0.0
50	-25.8	-21.0	-7.0	0.0
51	-28.3	-21.0	-7.0	0.0

Table 12. Low evaporator refrigerant temperature cutout (LERTC) and low water temperature cutout (LWTC) — propylene glycol (continued)

Glycol Percentage (%)	Solution Freeze Point (°F)	Minimum Recommended LERTC (°F)	Minimum Recommended LWTC (°F)	Minimum Chilled Water Set Point (°F)
52	-30.8	-21.0	-7.0	0.0
53	-33.4	-21.0	-7.0	0.0
54	-36.1	-21.0	-7.0	0.0
55	-38.9	-21.0	-7.0	0.0

Pump Package

Pump package applications include short water loops, decoupled systems and service for an entire loop volume. Because the fluid distribution system beyond the chiller is unknown, Trane Select Assist reports Available Head as the head leaving the brazed plate evaporator. Head leaving the evaporator includes the evaporator head loss, pump package piping frictional effects head losses, valve head losses, and strainer head loss summation.

NOTICE

Equipment Damage!

Failure to follow instructions could result in equipment damage.

Do not operate the pump package at $NPSH_R$. Operation at this suction head will cause cavitation. $NPSH_A$ should be at least 1.5 to 2.5 times $NPSH_R$.

Ambient freeze protection down to -4°F (-20°C) for water is included. Dependent on the freeze inhibitor solution, the freeze protection ambient temperature decreases accordingly.

The pump skid contains an independent pump motor starter panel. The pump starter panel's power supply is prewired into the chiller's control panel assembly. An independent pump motor power supply is not required. Variable pump speed command is integrated with the chiller controller allowing variable flow functionality.

Figure 10. Pump package unit — field water piping

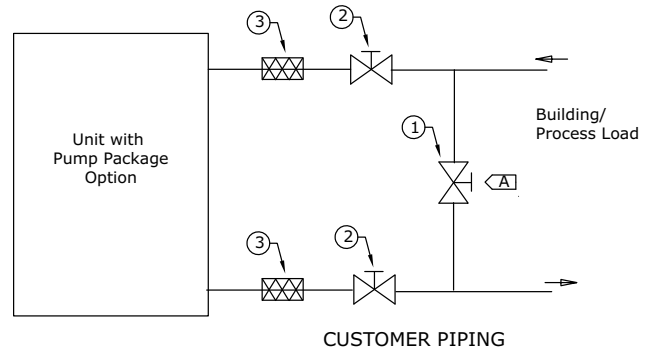
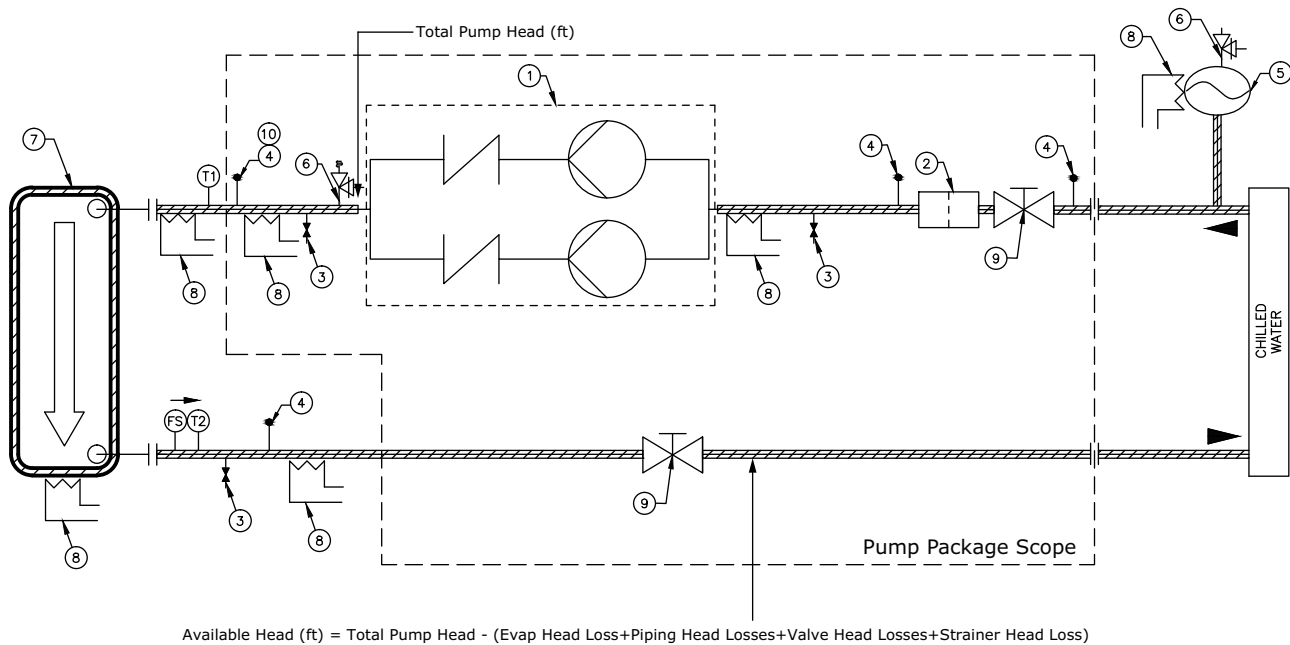

Table 13. Pump package unit — field water piping components

Item	Description
1	Bypass Valve
2	Isolator Valve
3	Vibration Eliminator
A	Isolate unit for initial water loop cleaning

Note: Water piping system shall be equipped with an expansion tank, field installed outside of pump package.

Figure 11. Pump package unit schematic



Item	Description	Item	Description	Item	Description
1	Pump — Single or Dual	6	Water Pressure Relief Valve	T1	Evap Inlet Temp Sensor
2	Water Strainer	7	BPHE	T2	Evap Outlet Temp Sensor
3	Drain Valve	8	Antifreeze Protection	FS	Flow Switch
4	Valve for Pressure Point	9	Butterfly Valve		
5	Expansion Tank	10	Manual Air Bleed		

Pump Package Available Head and Net Positive Suction Head (NPSH) Required

Pump package available head and NPSHR illustrated in these graphs are for water applications. Use Trane Select Assist to determine these values for applications with freeze avoidance solutions.

NOTICE

Equipment Damage!
 Failure to follow instructions could result in equipment damage.
 Do not operate the pump package at NPSH_R.
 Operation at this suction head will cause cavitation.
 NPSH_A should be at least 1.5 to 2.5 times NPSH_R.



Installation - Mechanical

Figure 12. ACS available head water 140 - 160

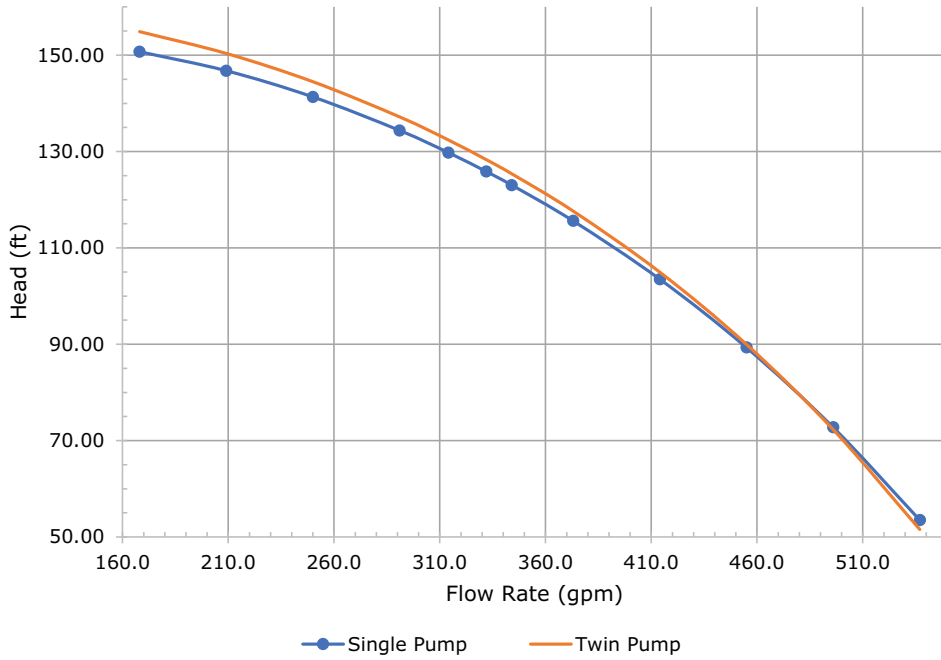

Figure 13. ACS available head water 180 - 200

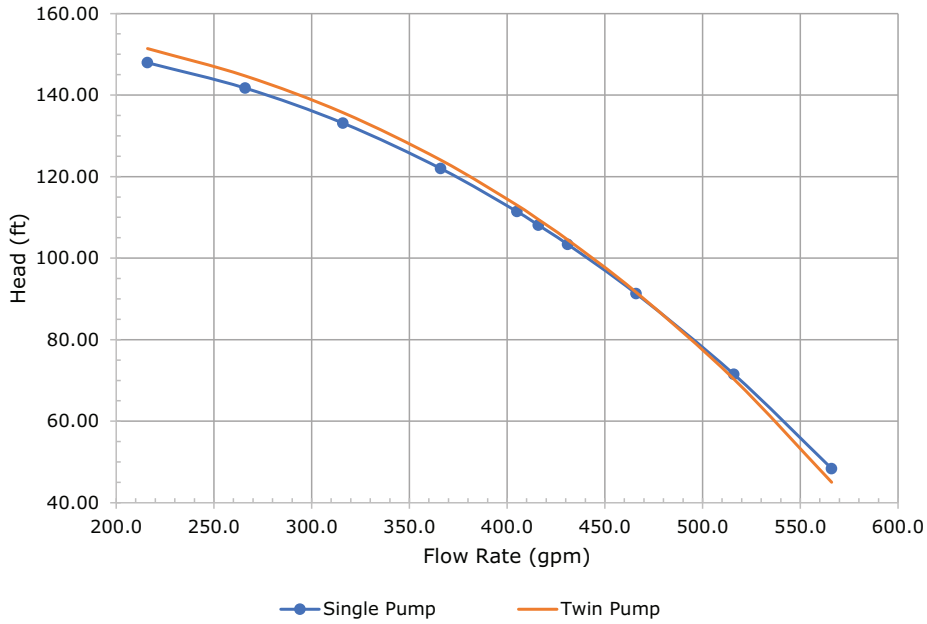

Figure 14. ACS available head water 215

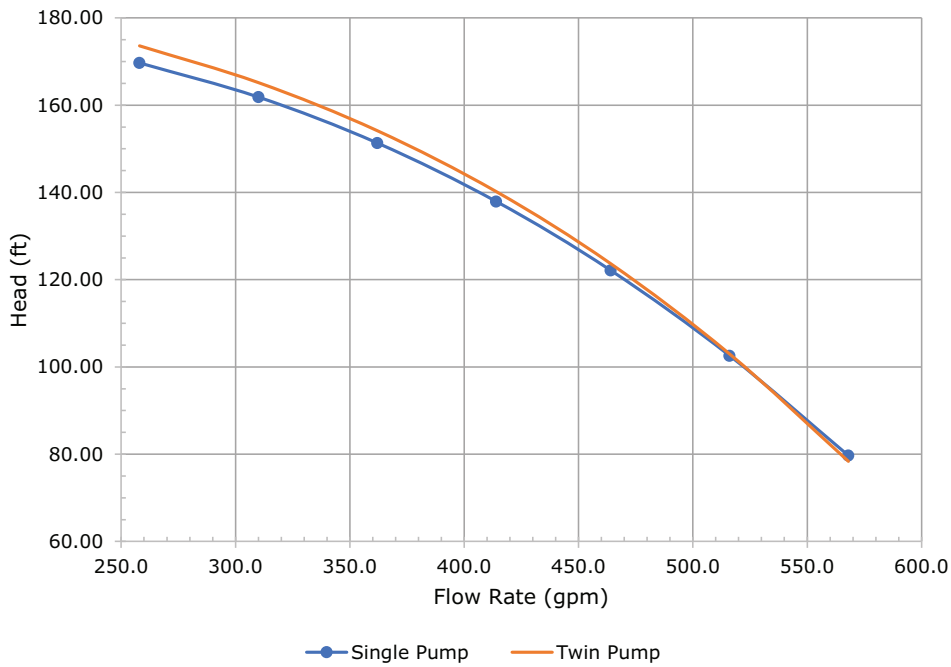

Figure 15. ACS available head water 230

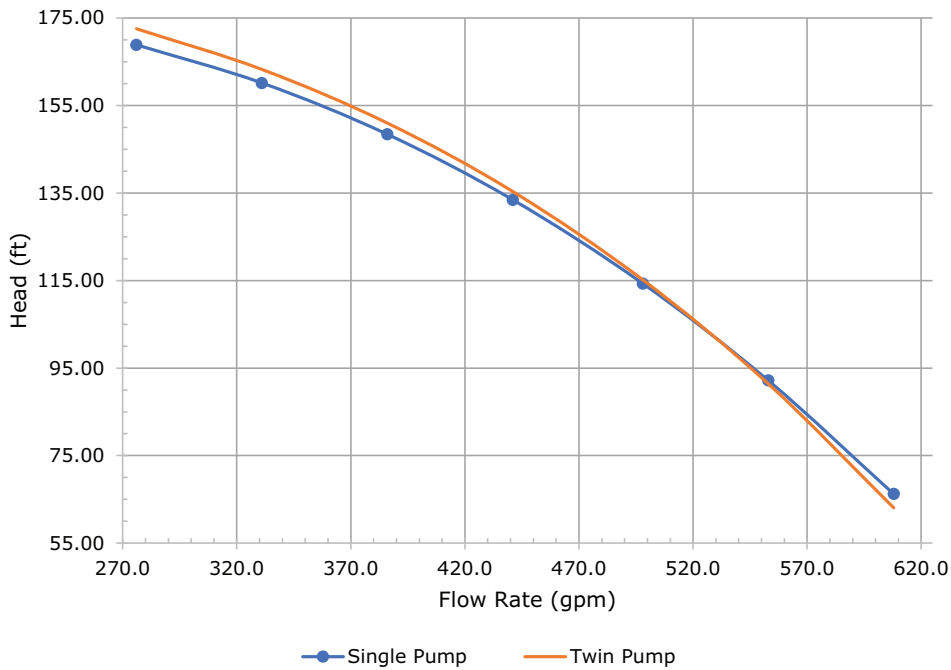

Figure 16. ACS NPSHR water 140 - 160

Figure 17. ACS NPSHR water 180-200

Figure 18. ACS NPSHR water 215

Figure 19. ACS NPSHR water 230

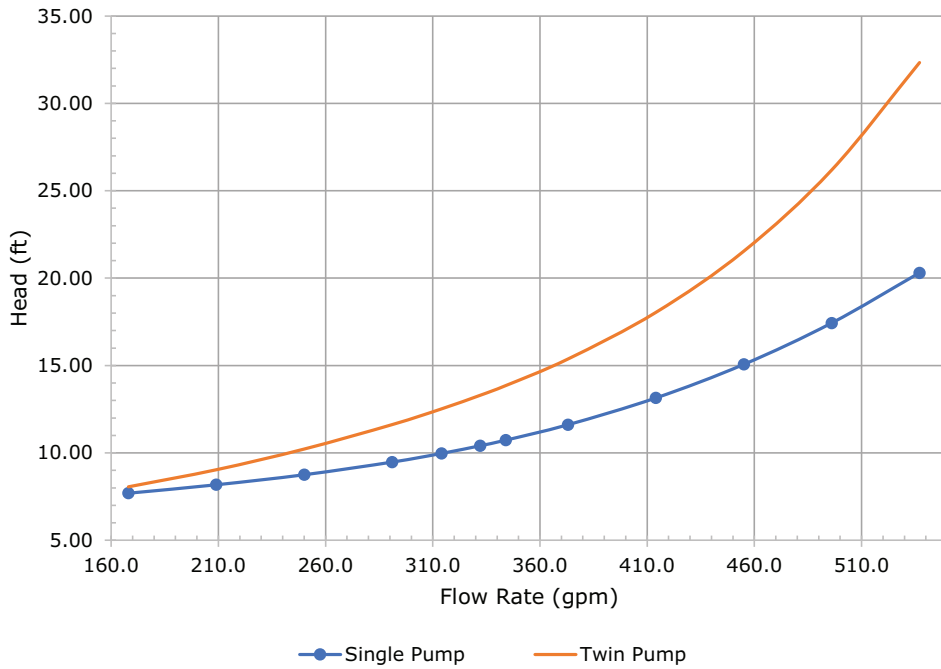
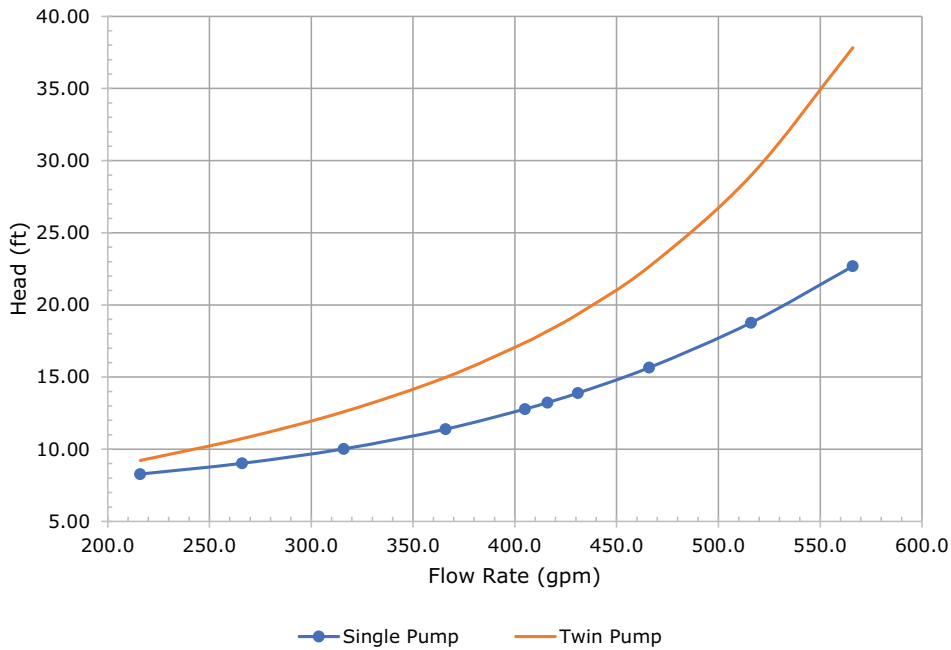
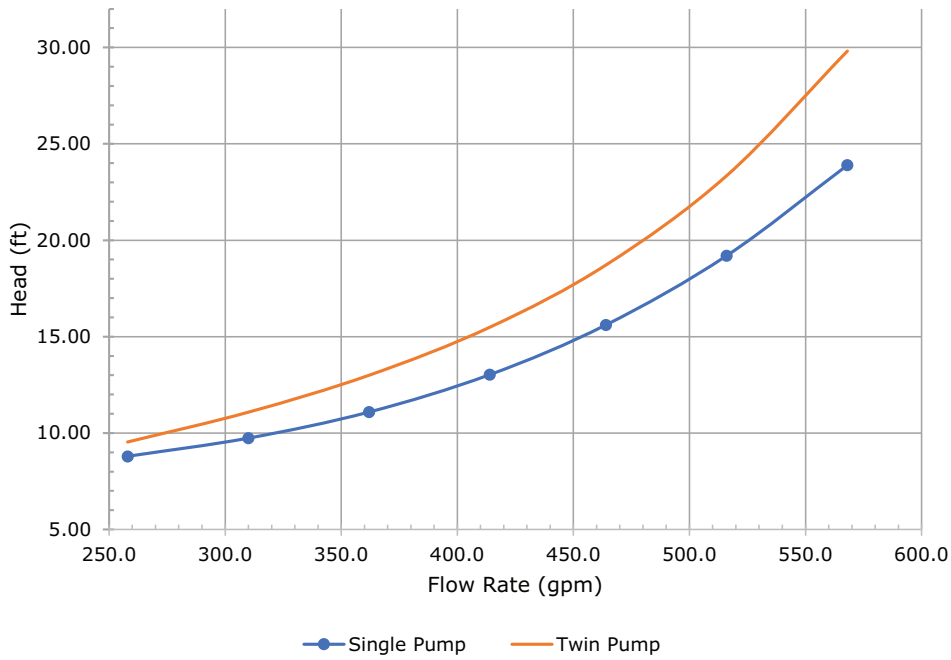
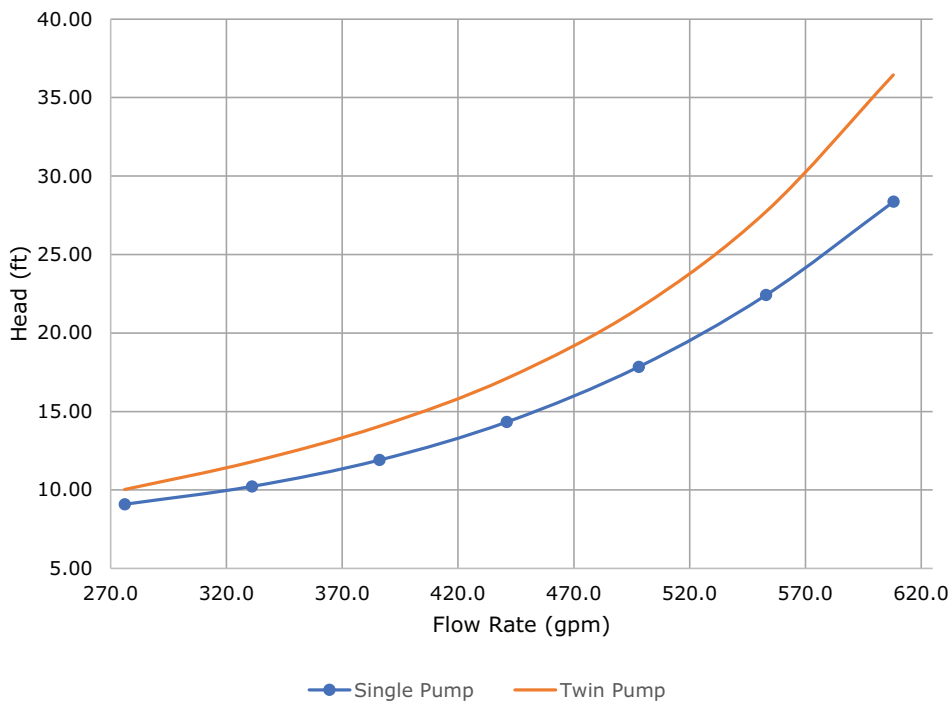

Installation - Mechanical

Expansion Tank

Water piping system shall be equipped with an expansion tank, field installed outside of pump package. Expansion tank should be capable of the thermal expansion of a loop

volume equivalent to three (3) minute loop at rated flow. See volume calculation methods in ASHRAE-Handbook-Equip. 2012, section 13.5.

Table 14. Expansion tank volume selection examples (diaphragm tank type)

Example	Description	Units	Unit Size (tons)					
			140	160	180	200	215	230
1	Maximum Pressure	psi	30	30	30	30	30	30
	Acceptance Expansion Tanks Volume Req.	gal	26	29	33	37	40	42
	Acceptance volume	gal	28	36	36	49	49	49
	Tank Volume Required	gal	33	37	42	46	50	53
2	Maximum Pressure	psi	45	45	45	45	45	45
	Acceptance Expansion Tanks Volume Req.	gal	22	25	28	31	33	36
	Acceptance volume	gal	28	28	36	36	36	36
	Tank Volume Required	gal	28	32	35	39	42	45
3	Maximum Pressure	psi	125	125	125	125	125	125
	Acceptance Expansion Tanks Volume Req.	gal	17	20	22	24	26	28
	Acceptance volume	gal	20	20	28	28	36	36
	Tank Volume Required	gal	22	25	28	31	33	36
4	Maximum Pressure	psi	150	150	150	150	150	150
	Acceptance Expansion Tanks Volume Req.	gal	17	19	21	24	26	27
	Acceptance volume	gal	20	20	28	28	28	28
	Tank Volume Required	gal	21	24	27	30	33	35



Installation Electrical

General Recommendations

As you review this manual, keep in mind that:

- All field-installed wiring must conform to National Electric Code (NEC) guidelines, and any applicable state and local codes. Be sure to satisfy proper equipment grounding requirements per NEC.
- Compressor motor and unit electrical data (including motor kW, voltage utilization range, rated load amps) is listed on the chiller nameplate.
- All field-installed wiring must be checked for proper terminations, and for possible shorts or grounds.

Note: Always refer to wiring diagrams shipped with chiller or unit submittal for specific electrical schematic and connection information.

⚠ WARNING

Hazardous Voltage!

Failure to disconnect power before servicing could result in death or serious injury.

Disconnect all electric power, including remote disconnects before servicing. Follow proper lockout/tagout procedures to ensure the power can not be inadvertently energized. Verify that no power is present with a voltmeter.

⚠ WARNING

Proper Field Wiring and Grounding Required!

Failure to follow code could result in death or serious injury.

All field wiring **MUST** be performed by qualified personnel. Improperly installed and grounded field wiring poses **FIRE** and **ELECTROCUTION** hazards. To avoid these hazards, you **MUST** follow requirements for field wiring installation and grounding as described in NEC and your local/state/national electrical codes.

NOTICE

Use Copper Conductors Only!

Failure to use copper conductors could result in equipment damage as the equipment was not designed or qualified to accept other types of conductors.

Important:

To prevent control malfunctions, do not run low voltage wiring (<30 V) in conduit with conductors carrying more than 30 volts.

Installer-Supplied Components

Customer wiring interface connections are shown in the electrical schematics and connection diagrams that are shipped with the unit. The installer must provide the following components if not ordered with the unit:

- Power supply wiring (in conduit) for all field-wired connections.
- All control (interconnecting) wiring (in conduit) for field supplied devices.
- Fused-disconnect switches or circuit breakers.

Power Supply Wiring

⚠ WARNING

Proper Field Wiring and Grounding Required!

Failure to follow code could result in death or serious injury.

All field wiring **MUST** be performed by qualified personnel. Improperly installed and grounded field wiring poses **FIRE** and **ELECTROCUTION** hazards. To avoid these hazards, you **MUST** follow requirements for field wiring installation and grounding as described in NEC and your local/state/national electrical codes.

All power supply wiring must be sized and selected accordingly by the project engineer in accordance with NEC Table 310.15(B)(16).

All wiring must comply with local codes and the National Electrical Code. The installing (or electrical) contractor must provide and install the system interconnecting wiring, as well as the power supply wiring. It must be properly sized and equipped with the appropriate fused disconnect switches.

The type and installation location(s) of the fused disconnects must comply with all applicable codes.

NOTICE

Use Copper Conductors Only!

Failure to use copper conductors could result in equipment damage as the equipment was not designed or qualified to accept other types of conductors.

See Dimensions and Weights chapter for location of incoming customer power locations in the control panel.

Cut holes into the location indicated for the appropriately-sized power wiring conduits. The wiring is passed through these conduits and connected to the terminal blocks, or circuit breakers.

The high voltage field-provided connections are made through patch plate on the right side of the main control panel.



Installation Electrical

To provide proper phasing of 3-phase input, make connections as shown in field wiring diagrams and as stated on the WARNING label in the starter panel. Proper equipment ground must be provided to each ground connection in the panel (one for each customer-supplied conductor per phase).

The low voltage connections are made through knockouts provided on the left side of the control panel. Additional grounds may be required for each 115 volt power supply to the unit. Green lugs are provided for 115V customer wiring.

Control Power Supply

The unit is equipped with a control power transformer. It is not necessary to provide additional control power voltage to the unit. No other loads should be connected to the control power transformer.

All units are factory-connected for appropriate labeled voltages.

Heater Power Supply

The evaporator shell is insulated from ambient air and protected from freezing for temperature down to -20°F (-29°C) by two thermostatically-controlled immersion heaters combined with evaporator pumps activation through Symbio 800. Whenever the ambient temperature drops below 32°F the thermostat energizes the heaters and the Symbio 800 activates the pumps. If ambient temperatures below -20°F (-29°C) are expected, contact your local Trane office.

NOTICE

Evaporator Damage!

Failure to follow below instructions could result in damage to the evaporator.

A qualified technician must frequently verify power to the immersion heaters and confirm operation of the heater thermostat. Control panel main processor does not check for loss of power to the immersion heater, nor does it verify thermostat operation.

NOTICE

Equipment Damage!

Failure to follow instructions below could result in evaporator damage.

If evaporator is drained, heaters must be turned off to avoid damage to the heaters or heating elements. Damaged heaters could cause evaporator damage when unit is back in operation.

Interconnecting Wiring

Chilled Water Pump Control

NOTICE

Evaporator Damage!

If the microprocessor calls for a pump to start and water does not flow, the evaporator may be damaged catastrophically.

It is the responsibility of the installing contractor and/or the customer to ensure that a pump will always be running when called upon by the chiller controls.

An evaporator water pump output relay's normally-open contact closes to start the evaporator water pump when the chiller is given a signal to go into the Auto mode of operation from any source. The contact is opened to turn off the pump in the event of most machine level diagnostics to prevent the build up of pump heat.

The relay output is required to operate the Evaporator Water Pump (EWP) contactor. The relay's contacts are compatible with 115/240 Vac control circuits. See Programmable Relays section for rating details. Normally, the EWP relay follows the AUTO mode of the chiller. Whenever the chiller has no diagnostics and is in the AUTO mode, regardless of where the auto command is coming from, the relay is energized and the normally-open contact is closed. When the chiller exits the AUTO mode, the relay's normally-open contact is timed to open in an adjustable (using Tracer® TU service tool) 0 to 30 minutes. The non-AUTO modes, in which the pump is stopped, include Reset, Stop, External Stop, Remote Display Stop, Stopped by Tracer, Start Inhibited by Low Ambient Temp, and Ice Building complete.

Table 15. Pump relay operation

Chiller Mode	Relay Operation
Auto	Instant Close
Ice Building	Instant Close
Tracer Override	Close
Stop	Timed Open
Ice Complete	Instant Open
Diagnostics	Instant Open

When going from Stop to Auto, the EWP relay is energized immediately. If evaporator water flow is not established in 20 minutes (for normal transition) or 4 minutes, 15 seconds (for pump commanded ON due to an override safety), the Symbio 800 de-energizes the EWP relay and generates a non-latching diagnostic. If flow returns (e.g. someone else is controlling the pump), the diagnostic is cleared, the EWP is re-energized, and normal control resumed.

If evaporator water flow is lost once it had been established, the EWP relay remains energized and a non-latching diagnostic is generated. If flow returns, the

diagnostic is cleared and the chiller returns to normal operation.

Lead/Lag Dual Pump

The running pump is changed each time the unit is switched on.

Programmable Relays

A programmable relay concept provides for enunciation or hardwired interlocking of certain events or states of the chiller, selected from a list of likely needs, while only using four physical output relays, as shown in the field wiring diagram. The four relays are provided (generally with a Quad Relay Output LLID) as part of the Programmable Relay Option. The relay's contacts are isolated Form C (SPDT), suitable for use with 120 VAC circuits drawing up to 2.8 amps inductive, 7.2 amps resistive, or 1/3 HP and for 240 VAC circuits drawing up to 0.5 amp resistive.

The list of events/states that can be assigned to the programmable relays can be found in the following table. The relay will be energized when the event/state occurs.

Table 16. Alarm and status relay output configurations

Description	
Alarm (Latching)	This output is true whenever there is an active latching shutdown diagnostic that targets the chiller, circuit, or any of the compressors on a circuit.
Alarm (Non-Latching)	This output is true whenever there is an active non-latching shutdown diagnostic that targets the chiller, circuit, or any of the compressors on a circuit.
Alarm	This output is true whenever there is any active latching or non-latching shutdown diagnostic that targets the chiller, circuit, or any of the compressors on a circuit.
Alarm Ckt 1	This output is true whenever there is any active latching or non-latching shutdown diagnostic that targets Circuit 1, or any of the Compressors on Circuit 1.
Alarm Ckt 2	This output is true whenever there is any active latching or non-latching shutdown diagnostic that targets Circuit 2, or any of the Compressors on Circuit 2.
Warning	This output is true whenever there is an active latching or non-latching informational diagnostic that targets the chiller, circuit, or any of the compressors on a circuit.
Chiller Limit Mode	This output is true whenever the chiller has been running in one of the limit modes (Condenser, Hot Evaporator Start, Demand or Compressor Inhibit) continuously for the Limit Relay debounce time. A given limit or overlapping of different limits must be in effect continuously for the debounce time prior to the output becoming true. It will become false if no limits are present for the debounce time.
Compressor Running	The output is true if any compressor on the unit is running.
Circuit 1 Running	The output is true whenever any compressor of Circuit 1 is running.

Table 16. Alarm and status relay output configurations (continued)

Description	
Circuit 2 Running	The output is true whenever any compressor of Circuit 2 is running.
Maximum Capacity	The output is true whenever the chiller has reached maximum capacity continuously for the Max Capacity Relay debounce time. The output is false when the chiller does not have all its available compressors running continuously for the debounce time. See the 'Maximum Capacity Annunciation' specification for more information.
Ice Making Status	The output is true if the unit is configured for ice building (aka Ice Making), the ice building feature is enabled, there are no ice building diagnostics, and ice building has been commanded. If the unit is not running and is then commanded into ice mode, the output should turn on before the first compressor starts. The output should false when the ice building cycle is complete. This output may be used to interlock with valves, etc. that need to be switched over to do the ice building cycle.
Hot Water Control Status	The output is true if capacity control is in Hot Water Control mode (the water temperature is being controlled to the Active Hot Water Setpoint). The output is false in any other capacity control mode (Chilled Water Control, Ice Building, etc.).
Defrost Status	The output is true if the unit is configured in Heat pump and one of the circuit is in Defrosting active mode. This output may be used to interlock with heating compensation provided by customer to balance the cooling capacity generated by defrost cycle.
Evaporator Water Freeze Avoidance Request	This relay output is energized any time either the Low Evaporator Water Temperature – Unit Off or the Low Evaporator Temperature Ckt x – Unit Off diagnostics are active. This relay is intended for use as an external interlock for a field engineered and provided solution to mitigate the freeze danger implied by these diagnostics. Generally, this would be used in cases where operation of the evaporator water pump is unacceptable due to the system constraints, (i.e. such as mixing unconditioned warm water with controlled supply water as provided by other parallel chillers. The relay's output can provide the method to close bypass valves so the circulation becomes local to the evaporator and excludes the load, or can be used to defeat the evaporator pump override entirely while initiating an independent source of heat / flow to the evaporator.
None	This selection is desirable to provide an easy way for a customer to defeat the effect of the relay, if it has already been wired. For instance, if the relay was normally programmed as an "alarm" relay, and was wired to a claxon, it may be desirable to temporarily defeat the feature without changing wiring.
Service Request (for unit compressor or water pump)	This relay will be energized when at least one Maintenance alert condition (refer to Service required message specification) occurs, as long as at least one of associated informational diagnostic (s) will be active.



Installation Electrical

Table 16. Alarm and status relay output configurations (continued)

Description	
Refrigerant Charge Loss Detected	If criteria that indicates refrigerant charge will be below a programmable trigger setpoint (adjustable), on at least one circuit, this relay will be energized. It will remain energized as long as associated informational diagnostic will be active.
Free Cooling Status	The output is true (closed) whenever Free Cooling is active and the capacity is > 0%. The output is false (open) whenever Free Cooling is inactive or capacity = 0%.
Free Cooling Maximum Capacity	The output is true (closed) whenever Free Cooling capacity – 100%. The output is false (open) whenever Free Cooling is <100% capacity.
Operation of the Relays	If any of the eight programmable annunciation relays are assigned with the given event or state, that relay shall be energized when the event or state is true and de-energized when the event or state is false pursuant to debounce or filter timing that may be applied per the details of a given assignment.

Relay Assignments Using Tracer TU

Tracer® TU Service Tool is used to install the Programmable Relay Option package and assign any of the above list of events or status to each of the four relays provided with the option. (See Tracer® TU section of Controls chapter for more information on this service tool.) The relays to be programmed are referred to by the relay's terminal numbers on the LLID board 1K23.

The default assignments for the four available relays of the Programmable Relay option are show in the table below.

Table 17. Default assignments

Relay	Assignment
Relay 1 Terminals J2-1,2,3:	Evaporator Freeze Avoidance Request
Relay 2 Terminals J2-4,5,6:	Maximum Capacity
Relay 3 Terminals J2 - 7,8,9:	Compressor Running
Relay 4 Terminals J2 -10,11,12:	Latching Alarm

The four available relays in the Lead/Lag Chiller Sequence Option are assigned with the following defaults as follows:

Table 18. Lead/lag chiller sequence option default assignments

LLID Name	LLID Software Relay Designation	Output Name	Default
Operating Status Programmable Relays Module	Relay 0	Status Relay 1, J2-1,2,3	Evaporator Water Freeze Avoidance Request
	Relay 1	Status Relay 2, J2-4,5,6	Maximum Capacity
	Relay 2	Status Relay 3, J2-7,8,9	Compressor Running
	Relay 3	Status Relay 4, J2-10,11,12	Latching Alarm

If any of the Alarm/Status relays are used, provide electrical power, 115 Vac with fused-disconnect to the panel and wire through the appropriate relays (terminals on 1K23). Provide wiring (switched hot, neutral, and ground connections) to the remote annunciation devices. Do not use power from the chiller's control panel transformer to power these remote devices. See the field wiring diagrams which are shipped with the unit.

Low Voltage Wiring

Emergency Stop

Symbio™ 800 provides auxiliary control for a customer specified/installed latching trip out. When this customer-furnished remote contact 5S1 is provided, the chiller will run normally when the contact is closed. When the contact opens, the unit will trip on a latching diagnostic. This latched condition requires either a manual reset at the front of the control panel or a power cycle of the Symbio™ 800 to clear.

Silver or gold-plated contacts are recommended. These customer-furnished contacts must be compatible with 24 Vdc, 12 mA resistive load.

External Auto/Stop

If the unit requires the external Auto/Stop function, the installer must provide leads from the remote contacts 5K1.

The chiller will run normally when the contacts are closed. When either contact opens, the compressor(s), if operating, will go to the RUN:UNLOAD operating mode and cycle off. Unit operation will be inhibited. Closure of the contacts will permit the unit to return to normal operation.

Field-supplied contacts for all low voltage connections must be compatible with dry circuit 24 Vdc for a 12 mA resistive load. Refer to the field diagrams that are shipped with the unit.

Ice Building Option

If Programmable Relay Option is included with Evaporator Application item 'Ice', Symbio 800 provides auxiliary control for a customer specified/installed contact closure for ice building if so configured and enabled. This output is known as the Ice Building Status Relay. The normally open contact will be closed when ice building is in progress and open when ice building has been normally terminated either through Ice Termination setpoint being reached or removal of the Ice Building command. This output is for use with the ice storage system equipment or controls (provided by others) to signal the system changes required as the chiller mode changes from "ice building" to "ice complete". When contact is provided, the chiller will run normally when the contact is open.

Symbio™ 800 will accept either an isolated contact closure (External Ice Building command) or a Remote Communicated input (Tracer) to initiate and command the Ice Building mode.

Symbio™ 800 also provides a "Front Panel Ice Termination Setpoint", settable through Tracer® TU, and adjustable from 20 to 32°F (-6.7 to 0°C) in at least 1°F (1°C) increments.

Note: *When in the ice building mode, and the evaporator entering water temperature drops below the ice termination setpoint, the chiller terminates the ice building mode and changes to the ice building complete mode.*

NOTICE

Equipment Damage!

Failure to follow instructions could result in damage to system components.

Freeze inhibitor must be adequate for the leaving water temperature.

Tracer® TU must also be used to enable or disable Ice Machine Control. This setting does not prevent the Tracer from commanding Ice Building mode.

Upon contact closure, the Symbio™ 800 will initiate an ice building mode, in which the unit runs fully loaded at all times. Ice building shall be terminated either by opening the contact or based on the entering evaporator water temperature. Symbio™ 800 will not permit the ice building mode to be reentered until the unit has been switched out of ice building mode and then switched back into ice building mode.

In ice building, all limits (freeze avoidance, evaporator, condenser, current) will be ignored. All safeties will be enforced.

If, while in ice building mode, the unit gets down to the freeze stat setting (water or refrigerant), the unit will shut down on a manually resettable diagnostic, just as in normal operation.

Connect leads to the proper terminals. Refer to the field diagrams which are shipped with the unit.

Silver or gold-plated contacts are recommended. These customer furnished contacts must be compatible with 24 VDC, 12 mA resistive load.

External Chilled/Hot Water Setpoint (ECHWS) Option

The Symbio™ 800 provides inputs that accept either 4-20 mA or 2-10 VDC signals to set the external chilled/hot water setpoint (ECHWS). This is not a reset function. The input defines the setpoint. This input is primarily used with generic building automation systems (BAS).

When the unit is in cooling mode, the external water setpoint (EWS) corresponds to the chilled water setpoint.

When the unit is in heating mode, the external water setpoint (EWS) corresponds to the hot water setpoint.

The external water setpoint shall have a configurable minimum and maximum set for cooling, and another one for heating.

The setpoints may be changed from a remote location by sending either a 2-10 VDC or 4-20 mA signal that corresponds to an EWS range with a configurable minimum and maximum value.

Table 19. Setpoint/signal relationships

Input Signal	External Water Setpoint
< 1 VDC	Invalid
1 VDC to 2 VDC	min
2 VDC to 10 VDC	$\text{min} + (\text{max} - \text{min}) * (\text{Signal} - 2) / 8$
10 VDC to 11 VDC	max
> 11 VDC	Invalid
< 2 mA	Invalid
2 mA to 4 mA	min
4 mA to 20 mA	$\text{min} + (\text{max} - \text{min}) * (\text{Signal} - 4) / 16$
20 mA to 22 mA	max
> 22 mA	Invalid

If the ECHWS input develops an open or short, the LLID will report either a very high or very low value back to the main processor. This will generate an informational diagnostic and the unit will default to using the front Panel (TD7) Chilled Water Setpoint.

Tracer® TU Service Tool is used to set the input signal type from the factory default of 2-10 VDC to that of 4-20 mA. Tracer® TU is also used to install or remove, enable or disable, the External Chilled Water Setpoint.

External Demand Limit Setpoint (EDLS) Option

Similar to the above, the Symbio™ 800 also provides for an optional External Demand Limit Setpoint that will accept either a 2-10 VDC (default) or a 4-20 mA signal. The Demand Limit Setting can also be set via the Tracer

AdaptiView™ TD7 or through digital communication with Tracer. The arbitration of the various sources of demand limit is described in the flow charts at the end of this section. The External Demand Limit Setpoint may be changed from a remote location by hooking up the analog input signal to the 1K24 LLID terminals 5 and 6. Refer to the following paragraph on Analog Input Signal Wiring Details. The following equations apply for EDLS:

If the EDLS input develops an open or short, the LLID will report either a very high or very low value back to the man processor. This will generate an informational diagnostic and the unit will default to using the Front Panel (Tracer AdaptiView™ TD7) Demand Limit Setpoint.

The Tracer® TU Service Tool must be used to set the input signal type from the factory default of 2-10 VDC to that of 4-20 mA current. Tracer TU must also be used to install or remove the External Demand Limit Setpoint Option for field installation, or can be used to enable or disable the feature (if installed).

Figure 20. Demand limit setpoint via 2–10 VDC signal

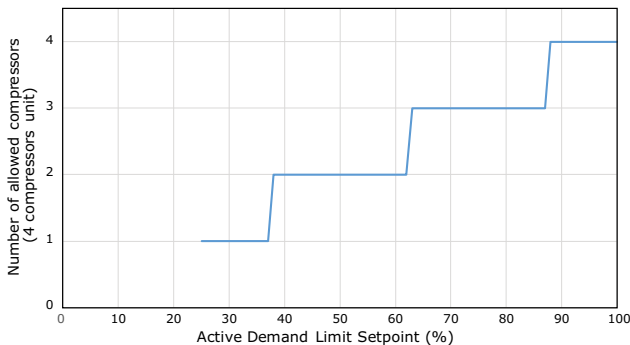
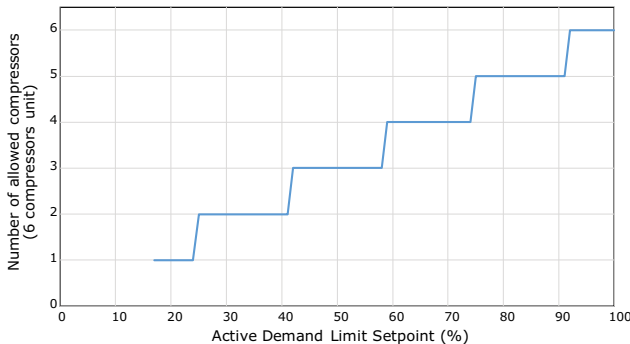

Figure 21. Demand limit setpoint via 4–20 mA signal



EDLS and ECHWS Analog Input Signal Wiring

Both the ECHWS and EDLS can be connected and setup as either a 2-10 VDC (factory default), 4-20 mA, or resistance input (also a form of 4-20mA) as indicated below. Depending on the type to be used, the Tracer® TU Service Tool must be used to configure the LLID and the unit controller for the proper input type that is being used. This is accomplished by a setting change on the Custom Tab of the Configuration View within Tracer® TU.

Important: For proper unit operation, BOTH the EDLS and ECHWS settings MUST be the same (2-10 VDC or 4-20mA), even if only one input is to be used.

When not Installed, external chilled hot water setpoint analog input, external demand limit setpoint analog input and auxiliary binary input setpoint enable will not be used (Front panel or BAS sources used, depending which one is valid).

Setpoint Source selections are: BAS/Ext/FP, Ext/FP, or Front Panel

When Installed, both analog I/O and binary will be used, with respect of following status:

- **External chilled hot water setpoint:** IF it is the highest priority and it is a valid source THEN use this external setpoint for active chilled water setpoint.
- **External demand limit setpoint:** IF it is the highest priority and it is a valid source THEN use this external setpoint for active demand limit setpoint.
- **External auxiliary chilled hot water setpoint enable input:** IF setpoint source is set to external/Front Panel or Front Panel THEN:
 - IF input open, use the next highest priority setpoint source (see priority list below)
 - IF input closed, use the auxiliary chilled water setpoint

Priority (from highest to lowest):

- BAS communication (BACnet®, LonTalk® or Modbus™)
- Ice Building
- External setpoints
- Front Panel setpoints

Chilled Water Reset (CWR)

Symbio 800 resets the chilled water temperature setpoint based on either return water temperature, or outdoor air temperature. Return Reset is standard, Outdoor Reset is optional.

The following shall be selectable:

- One of three Reset types: None, Return Water Temperature Reset, Outdoor Air Temperature Reset, or Constant Return Water Temperature Reset.
- Reset Ratio setpoints: For outdoor air temperature reset there shall be both positive and negative reset ratios.
- Start Reset Setpoints.
- Maximum Reset setpoints.

Variable Definitions

- CWS is the arbitrated chilled water setpoint before any reset has occurred
- CWS' is the active chilled water setpoint, includes the effect of chilled water reset

- CWR is the amount of chilled water reset (also called Degrees of Reset)

The above values are related by the equations:

$$CWS' = CWS + CWR$$

OR

$$CWR = CWS' - CWS$$

With the chiller running and any type of chilled water reset enabled, CWR is allowed to change at a maximum rate of 1°F every 5 minutes until the actual CWR equals the desired CWR. When the chiller is not running, actual CWR shall be set equal to the desired CWR within one minute (no maximum rate is in effect).

If Chilled Water Reset is disabled, desired CWR is 0.

Additional Variable Definitions

- RESET RATIO is a user adjustable gain
- START RESET is a user adjustable reference
- TOD is the outdoor air temperature
- TWE is evaporator entering water temperature
- TWL is evaporator leaving water temperature
- MAXIMUM RESET is a user adjustable limit providing the maximum amount of reset. For all types of reset, $CWS' - CWS < \text{or} = \text{Maximum Reset}$.

The equations for each type of reset are as follows:

Return

$$CWR = \text{RESET RATIO} * + [\text{START RESET} - (\text{TWE} - \text{TWL})]$$

with limits:

- $CWR > \text{or} = 0$
- $CWR < \text{or} = \text{Maximum Reset}$

Outdoor

$$CWR = \text{RESET RATIO} * + (\text{START RESET} - \text{TOD})$$

with limits:

- $CWR > \text{or} = 0$
- $CWR < \text{or} = \text{Maximum Reset}$

Constant Return Water Temperature Reset

$$CWR = 100\% * [\text{Design Delta Temperature} - (\text{TWE} - \text{TWL})]$$

with limits:

- $CWR > \text{or} = 0$
- $CWR < \text{or} = \text{Maximum Reset}$

Using Equations for Calculating CWR

Degrees of Reset

- OUTSIDE AIR: Degrees of Reset = $\text{Reset Ratio} * (\text{Start Reset} - \text{TOD})$
- RETURN RESET: Degrees of Reset = $\text{Reset Ratio} * [\text{Start Reset} - (\text{TWE} - \text{TWL})]$
- DEGREES OF RESET = $100\% * [\text{Design Delta Temp} - (\text{TWE} - \text{TWL})]$

Active CWS from Degrees of Reset

$$\text{Active CWS} = \text{Degrees of Reset} + \text{Arbitrated CWS}$$

Note: Arbitrated CWS can either be Front Panel, BAS, or External

Reset Ratio

The Reset Ratio on the User Interface is displayed as a percentage. To use it in the above equation it must be converted to its decimal form:

$$\text{Reset Ratio percent}/100 = \text{Reset Ratio decimal}$$

Example of converting Reset Ratio:

If the Reset Ratio displayed on the User Interface is 50% then use $(50/100) = 0.5$ in the equation.

Diagnostic

If any sensor measurement needed to perform the currently selected chilled water reset type is invalid due to loss of communication or sensor failure, the desired CWR will be set to 0. The actual CWR is subject to maximum rate limits described earlier.

Communications Interface

LonTalk Interface (LCI-C)

The LonTalk communication protocol for the Symbio™ 800 controller expands communications from the unit UCM network to a Tracer® Ensemble™ building automation system or third party building automation system. Utilizing LonTalk®, the BAS allows external setpoint and configuration adjustment and monitoring of status and diagnostics. The Symbio 800 utilizes an FTT-10A free topology transceiver, which supports non-polarity sensitive, free topology wiring—which in turn allows the system installer to utilize star, bus, and loop architectures. This controller works in standalone mode, peer-to-peer with one or more other units, or when connected to a Tracer Ensemble, Tracer SC+, or a third party building automation system that supports LonTalk.

BACnet Interface (BCI-C)

The BACnet® control network for Symbio 800 expands communications from the unit UCM network to the Tracer Ensemble or Tracer SC+ building automation system or third party building automation system. Utilizing BACnet, the BAS allows external setpoint and configuration adjustment and monitoring of status and diagnostics. The Symbio 800 utilizes the BACnet defined MS/TP protocol as defined in ASHRAE standard 135-2004. This controller works in standalone mode, with Tracer Ensemble, Tracer SC+ or when connected to a third party building automation system that supports BACnet.

Modbus Remote Terminal Unit Interface

Allows the user to easily interface with Modbus™ RTU communication protocol via a single twisted pair wiring from the Symbio 800 controller to a factory installed device.



Operating Principles

This section contains an overview of the operation of Ascend™ Model ACS and ACX air-cooled liquid chiller equipped with microcomputer-based control system.

Note: *To ensure proper diagnosis and repair, contact a qualified service organization if a problem could occur.*

General

Ascend Model ACS and ACX units are scroll compressor, dual circuit, air-cooled liquid chillers. These units are equipped with unit-mounted starter/control panels and operate with R-454B refrigerant.

The basic components are:

- Unit-mounted panel containing starter and Symbio™ 800 controller and Input/Output LLIDs
- Scroll compressors
- Brazed-plate evaporator
- Air-cooled Microchannel (MCHE) condenser with subcooler in ACS or RTPF condenser in ACX
- Electronic Expansion Valve (EXV)
- Relating interconnecting piping

Refrigerant Cycle

The refrigeration cycle of the ACS or ACX chiller is conceptually similar to other Trane air-cooled chiller products. The chiller uses a brazed plate evaporator and an air-cooled MCHE or RTPF condenser. The compressors use suction gas cooled motors and an oil management system to provide almost oil-free refrigerant to the condenser and evaporator for maximum heat transfer while lubricating and sealing compressor rotors and bearings. The lubrication system helps to assure long compressor life and contributes to quiet operation.

Refrigerant condenses in the MCHE or RTPF air-cooled heat exchanger. Liquid refrigerant is metered into the brazed plate evaporator using an electronic expansion valve to maximize chiller efficiency at full and part load operation.

The chiller is equipped with a unit-mounted starter and control panel. Microprocessor based unit control modules (Trane Symbio™ 800) provide accurate chilled water control and providing monitoring, protection and adaptive limit functions. The adaptive nature of the controls intelligently prevent the chiller from operating outside of its limits, or compensates for unusual operating conditions while keeping the chiller running rather than simply shutting off the chiller. If problems do occur, the Symbio 800 controls provide diagnostic messages to help the operator in troubleshooting.

Oil System

The oil is efficiently separated inside the scroll compressor and will remain in the scroll compressor during all run cycles. Between 1-2% of the oil circulates around with the refrigerant.

See compressor section for oil level information.

Condenser and Fans

The air-cooled microchannel condenser coils use all aluminum brazed fin construction. The coil is composed of three components: the flat microchannel tube, the fins located between the microchannel tubes, and two refrigerant manifolds. Coils can be cleaned with high pressure water. (See Maintenance chapter for instructions.) The condenser coil has an integral subcooling circuit. Condensers are factory proof and leak tested at 650 psig. Direct-drive vertical-discharge airfoil condenser fans are dynamically balanced.



Controls

Overview

Ascend™ chillers utilize the following control/interface components:

- Symbio™ 800 Controller
- Tracer® AdaptiView™ TD7 Operator Interface

Symbio™ 800

The Symbio 800 controller is a factory-installed, application specific and programmable controller designed to control chillers and large packaged HVAC equipment. A 7 inch user interface features a touch-sensitive color screen that provides facility managers at-a-glance operating status, performance monitoring, scheduling changes, and operating adjustments. Other advanced features include automated controller back-up, and optional features such as secure remote connectivity, wireless building communications, mobile device connectivity, and custom programming with an expandable I/O.

For more information, see *Symbio™ 800 Controller Installation, Operation, and Maintenance* (BAS-SVX080*-EN).

AdaptiView™ Display

Information is tailored to operators, service technicians, and owners. When operating a chiller, specific information is needed on a day-to-day basis—setpoints, limits, diagnostic information, and reports. This information is provided through the AdaptiView display. Logically organized groups of information — chiller modes of operation, active diagnostics, settings and reports put information conveniently at your fingertips.

For more information, see *Ascend Air-Cooled Chiller Model ACS AdaptiView™ Display with Symbio™ Controls User Guide* (AC-SVU002*-EN).

Tracer TU

The AdaptiView TD7 operator interface allows for daily operational tasks and setpoint changes. However, to adequately service chillers, Tracer® TU service tool is required. (Non-Trane personnel, contact your local Trane office for software purchase information.) Tracer TU adds a level of sophistication that improves service technician effectiveness and minimizes chiller downtime. This

portable PC-based service-tool software supports service and maintenance tasks, and is required for software upgrades, configuration changes and major service tasks.

Tracer TU serves as a common interface to all Trane chillers, and will customize itself based on the properties of the chiller with which it is communicating. Thus, the service technician learns only one service interface.

The panel bus is easy to troubleshoot using LED sensor verification. Only the defective device is replaced. Tracer TU can communicate with individual devices or groups of devices.

All chiller status, machine configuration settings, customizable limits, and up to 100 active or historic diagnostics are displayed through the service-tool software interface.

LEDs and their respective Tracer TU indicators visually confirm the availability of each connected sensor, relay, and actuator.

Tracer TU is designed to run on a customer’s laptop, connected to the Symbio™ 800 control panel with a USB cable. See *Tracer® TU Service Tool User Guide* (BAS-SVU046*-EN) for laptop requirements.

Notes:

- *Tracer TU is designed and validated for this minimum laptop configuration. Any variation from this configuration may have different results. Therefore, support for Tracer TU is limited to only those laptops with the configuration previously specified.*
- *For more information, see Tracer®TU Service Tool User Guide (BAS-SVU046*-EN).*

Figure 22. Tracer TU

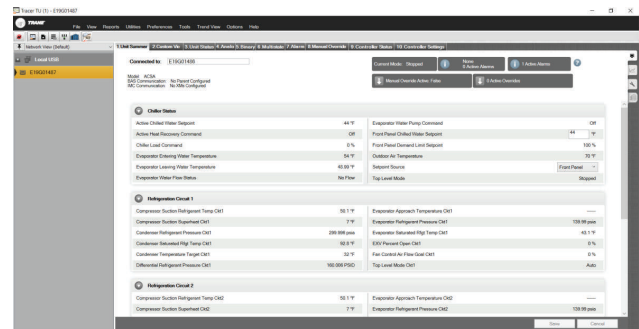



Pre-Start

Upon completion of installation, complete the Installation Completion Check Sheet and Request for Trane Service checklist in Log and Check Sheet chapter.

Important: *Start-up must be performed by Trane or an agent of Trane specifically authorized to perform start-up and warranty of Trane products. Contractor shall provide Trane (or an agent of Trane specifically authorized to perform start-up) with notice of the scheduled start-up at least two weeks prior to the scheduled start-up.*



Start-up and Shutdown

Important: Initial unit commissioning start-up must be performed by Trane or an agent of Trane specifically authorized to perform start-up and warranty of Trane products. Contractor shall provide Trane (or an agent of Trane specifically authorized to perform start-up) with notice of the scheduled start-up at least two weeks prior to the scheduled start-up.

Unit Start-up

NOTICE

Equipment Damage!

Failure to follow instructions could result in equipment damage.

Ensure that the compressor and oil sump heaters have been operating properly for a minimum of 24 hours before starting.

NOTICE

Equipment Damage!

Snow, ice, or debris build up on fans could cause excessive imbalance and equipment damage.

Clear fans of build up prior to machine start-up.

If required, once the system has been operating for approximately 30 minutes and has become stabilized, complete the remaining start-up procedures, as follows:

1. Check the evaporator refrigerant pressure and the condenser refrigerant pressure under Subcomponent Report on the AdaptiView™ TD7 or Tracer® TU. The pressures are referenced to sea level (14.6960 psia).
2. Check the EXV sight glasses after sufficient time has elapsed to stabilize the chiller. The refrigerant flow past the sight glasses should be clear. Bubbles in the refrigerant indicate either low refrigerant charge or excessive pressure drop in the liquid line or a stuck open expansion valve. A restriction in the line can sometimes be identified by a noticeable temperature differential between the two sides of the restriction. Frost will often form on the line at this point. Proper refrigerant charges are shown in the General Information Section.

Important: A clear sight glass alone does not mean that the system is properly charged. Also check system subcooling, liquid level control and unit operating pressures.

If chiller is limited by any limiting conditions, contact local Trane service organization for more information.

Temporary Shutdown And Restart

To shut the unit down for a short time, use the following procedure:

1. Press the STOP key on the AdaptiView™ TD7. The compressors will continue to operate and an operational pumpdown cycle may be initiated.
2. Symbio™ 800 pump control will turn off the pump (after a minimum 1 min. delay) when the STOP key is pressed and automatically restart the pump when the unit starts normally.

To restart the unit after a temporary shutdown, enable the chilled-water pump and press the AUTO key. The unit will start normally, provided the following conditions exist:

- The Symbio™ 800 receives a call for cooling and the differential-to-start is above the setpoint.
- All system operating interlocks and safety circuits are satisfied.

Extended Shutdown Procedure

The following procedure is to be followed if the system is to be taken out of service for an extended period of time, e.g. seasonal shutdown:

1. Perform normal unit stop sequence.
2. Verify that compressor oil sump heaters are installed tightly around compressor. Energize and verify heaters are operational using a temperature probe. See table below. Install jumper across thermostat and verify current flow.

NOTICE

Heater Damage!

Failure to follow instructions below could cause equipment damage.

De-energize evaporator immersion heater and/or any associated evaporator water piping immersion heaters when draining evaporator or evaporator water piping.



Start-up and Shutdown

Table 20. Freeze protection heater summary

Heater	Thermostat	Jumper	Heater Description	Heaters
Evap and Water Pipe Heaters	6B52	6X1-2 to 6X1-3	Evaporator	6E50-1
			Evap Entering Water	6E50-3
			Evap Leaving Water	6E50-2
Pump Package (optional)	6B53	6X2-2 to 6X2-4 6X2-3 to 6x2-5	Water Pump Piping	6E51-1, 6E51-2, 6E51-3, 6E51-4, 6E51-5

Note: Not all heaters are present on all unit configurations. See schematics and component locations in AC-SVE002*-EN.

- Once unit is secured, perform tasks as outlined in the Maintenance chapter.

Seasonal Unit Start-up Procedure

- PRIOR to water being pumped into system, use gauges to verify positive pressure in the evaporator and condenser. Lack of pressure could indicate a system leak. In the event that no pressure is present, contact local Trane service.
- Close all drain valves and re-install the drain plugs in the evaporator.
- Service the auxiliary equipment according to the start-up/maintenance instructions provided by the respective equipment manufacturers.
- Close the vents in the evaporator chilled water circuits.
- Open all the valves in the evaporator chilled water circuits.
- Open all refrigerant valves or verify they are in the open condition.
- If the evaporator was previously drained, vent and fill the evaporator and chilled water circuit. When all air is removed from the system (including each pass), install the vent plugs.
- Check the adjustment and operation of each safety and operating control.
- Refer to the sequence for daily unit start-up for the remainder of the seasonal start-up.

System Restart After Extended Shutdown

NOTICE

Equipment Damage!

Failure to follow instructions could result in equipment damage.

Ensure that the compressor and oil sump heaters have been operating properly for a minimum of 24 hours before starting.

Follow the procedures below to restart the unit after extended shutdown:

- Check refrigerant pressure as noted in Seasonal Unit Start-Up procedure.
- Verify that the liquid line service valves, oil line, compressor discharge service valves and suction service valves are open (backseated).

NOTICE

Compressor Damage!

Failure to follow instructions below could cause catastrophic damage to the compressor.

Do not leave oil line shut off valve or the isolation valves closed on unit start-up.

- Check the oil sump level. See instructions in Maintenance chapter.
- Fill the evaporator water circuit. Vent the system while it is being filled. Open the vent on the top of the evaporator and condenser while filling and close when filling is completed.

NOTICE

Proper Water Treatment Required!

The use of untreated or improperly treated water could result in scaling, erosion, corrosion, algae or slime.

Use the services of a qualified water treatment specialist to determine what water treatment, if any, is required. Trane assumes no responsibility for equipment failures which result from untreated or improperly treated water, or saline or brackish water.

- Close the fused-disconnect switches that provides power to the chilled water pump.
- Start the evaporator water pump and, while water is circulating, inspect all piping for leakage. Make any necessary repairs before starting the unit.
- While the water is circulating, adjust the water flows and check the water pressure drops through the evaporator. See Evaporator Waterside Pressure Drop Curves in Installation Mechanical chapter, and water flow rates in General Data tables.
- Verify proper operation of flow switch on the evaporator waterbox.
- Stop the water pump. The unit is now ready for start-up

as described previously

Sequence of Operation

This section provides basic information on chiller operation for common events. Adaptive control algorithms are used on these chillers. This section illustrates common control sequences.

Software Operation Overview

The following figure is a diagram of the five possible software states. This diagram can be thought of as a state chart, with the arrows and arrow text, depicting the transitions between states:

- The text in the circles is the internal software designations for each state.
- The shading of each software state circle corresponds to the shading on the time lines that show the chiller's state.

There are five generic states that the software can be in:

- Power Up
- Stopped
- Starting
- Running
- Stopping

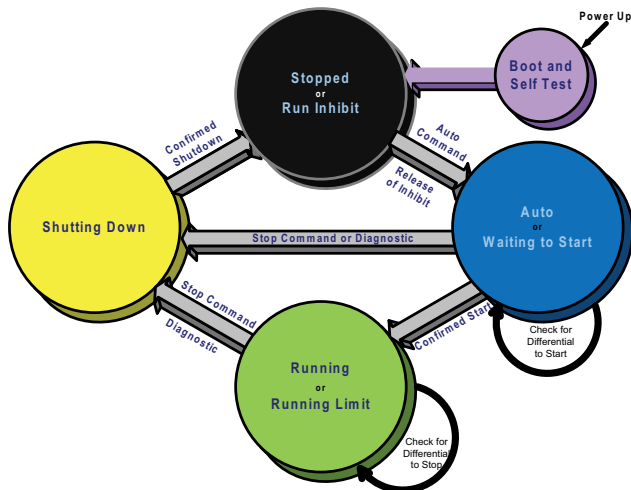

In the following diagrams:

- The time line indicates the upper level operating mode, as it would be viewed in the Tracer® AdaptiView™.
- The shading color of the cylinder indicates the software state.
- Text in parentheses indicates sub-mode text as viewed in the Tracer AdaptiView.
- Text above the time line cylinder is used to illustrate inputs to the Symbio 800. This may include user input to the Tracer AdaptiView touch screen, control inputs from sensors, or control inputs from a generic BAS.
- Boxes indicate control actions such as turning on relays, or pulsing compressor load or unload solenoids.
- Smaller cylinders under the main cylinder indicate diagnostic checks.
- Text outside a box or cylinder indicates time-based functions.
- Solid double arrows indicate fixed timers.
- Dashed double arrows indicate variable timers.

Power Up Diagram

The following diagram shows the respective TD7 AdaptiView™ screens during a power up of the Symbio 800 and display. This process takes 15 seconds for the Symbio 800 and 105 seconds for the display. On all power ups, the software model always will transition through the 'Stopped' Software state independent of the last mode. If the last mode before power down was 'Auto', the transition from 'Stopped' to 'Starting' occurs, but it is not apparent to the user.

Start-up and Shutdown

Figure 23. Sequence of operation: power up diagram

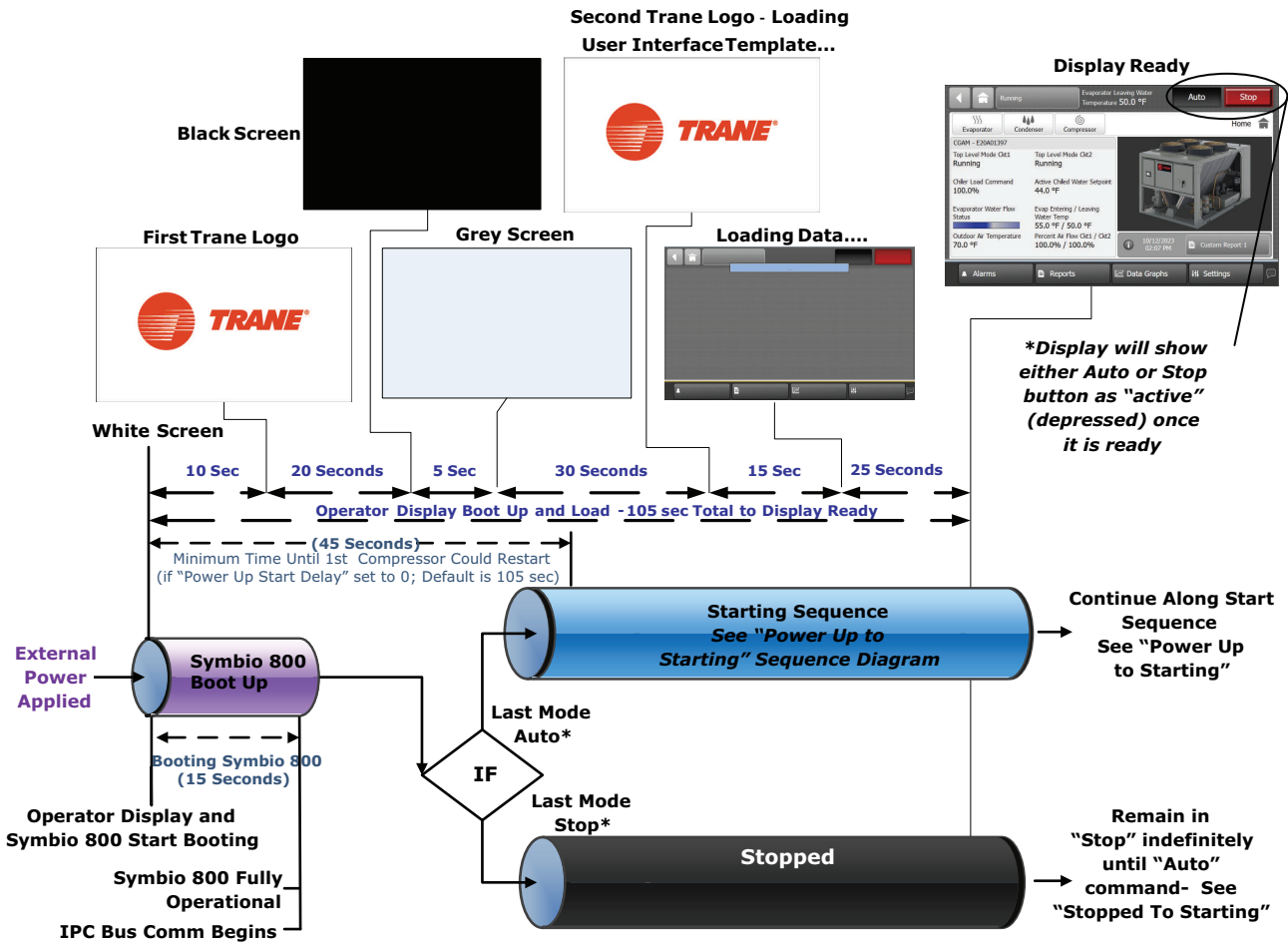

Power Up to Starting

The following diagram shows the timing from a power up event to energizing the first compressor. The shortest allowable time would be under the following conditions:

- No motor restart inhibit time left from subsequent starts
- Evaporator Water flow occurs quickly with pump on command
- Power up Start Delay set to 0 minutes

- Need to cool (differential to start) already exists
- Oil level is detected immediately

The above conditions would allow for a minimum power up to starting the first compressor time of about 45 seconds (variations may exist due to options installed). Note that it is not advisable to start a chiller “cold”, the oil heaters should be in operation for a sufficient length of time prior to first start.

Figure 24. Sequence of operation: power up to starting

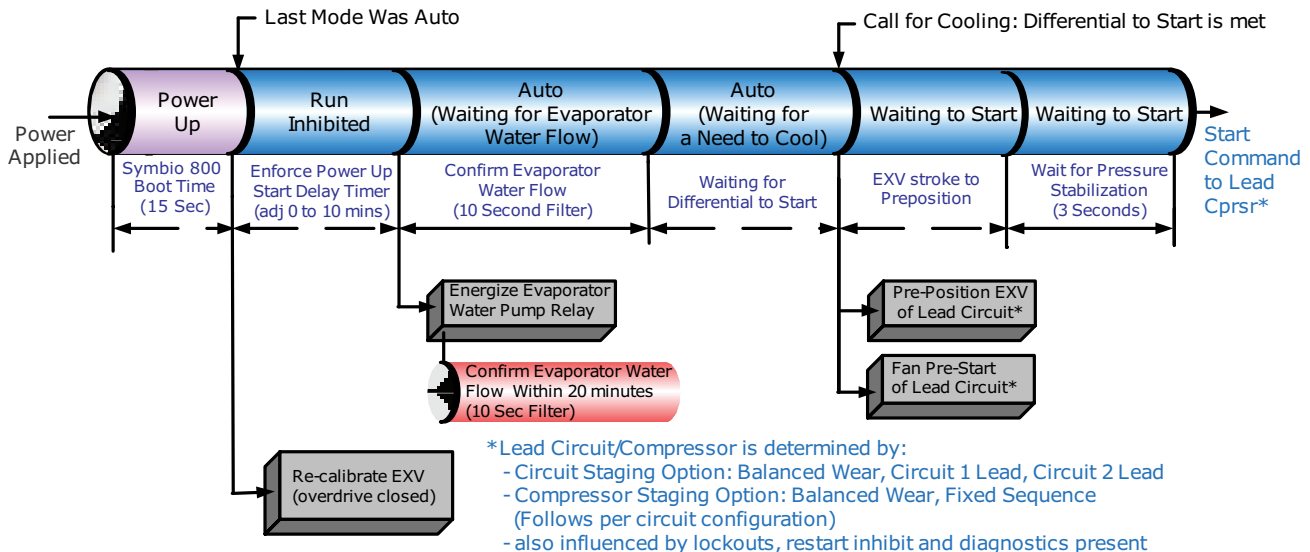

Start-up and Shutdown

Stopped to Starting

The following diagram shows the timing from a stopped mode to energizing the first compressor. The shortest allowable time would be under the following conditions:

- No motor restart inhibit time left from subsequent starts

- Evaporator Water flow occurs quickly with pump on command
- Need to cool (differential to start) already exists
- The above conditions would allow a compressor to start in about 20 seconds.

Figure 25. Sequence of operation: stopped to starting

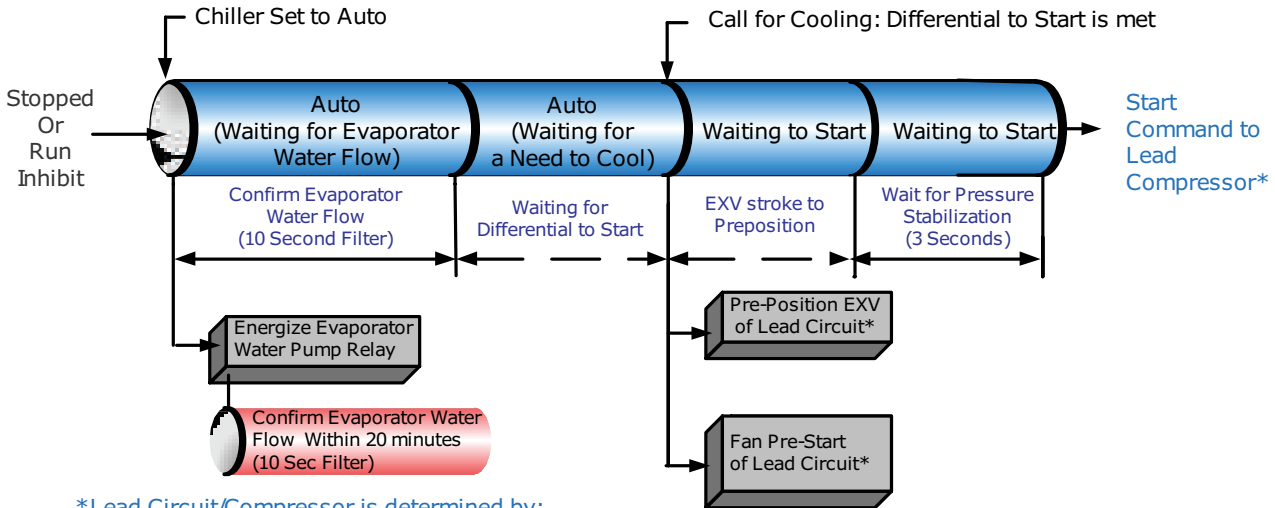

*Lead Circuit/Compressor is determined by:

- Circuit Staging Option: Balanced Wear, Circuit 1 Lead, Circuit 2 Lead
- Compressor Staging Option: Balanced Wear, Fixed Sequence (Follows per circuit configuration)
- also influenced by lockouts, restart inhibit and diagnostics present

Normal Shutdown to Stopped or Run Inhibit

the top attempt to show the final mode if stop is selected via various inputs.

The following diagram shows the Transition from Running through a Normal (friendly) Shutdown. The dashed lines on

Figure 26. Sequence of operation: normal shutdown to stopped or run inhibit

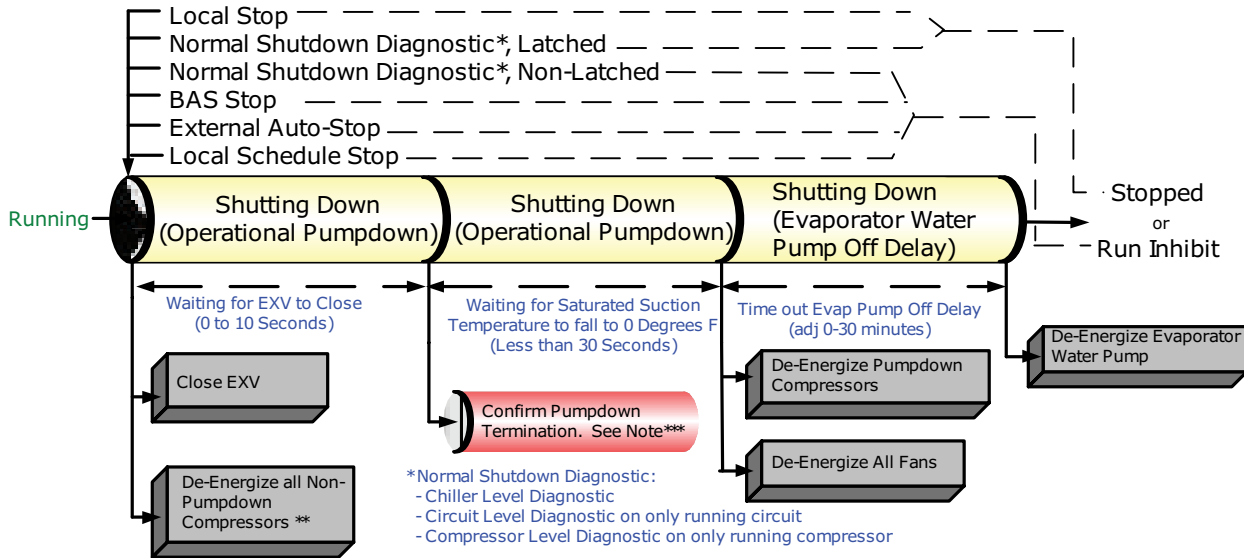



Maintenance

⚠ WARNING

Hazardous Voltage - Pressurized Flammable Fluid!

Failure to follow all electrical safety precautions could result in death or serious injury.

Do not operate compressor without terminal box cover in place.

The motors in the compressors have strong permanent magnet motors and have the capability to generate voltage during situations when the refrigerant charge is being migrated. This potential will be present at the motor terminals and at the output of the variable speed drives in the power panel.

Before removing compressor terminal box cover for servicing, or servicing power side of control panel, CLOSE COMPRESSOR DISCHARGE SERVICE VALVE and disconnect all electric power including remote disconnects. Discharge all motor start/run capacitors. Follow lockout/tagout procedures to ensure the power cannot be inadvertently energized. Verify with an appropriate voltmeter that all capacitors have discharged.

The compressor contains hot, pressurized refrigerant. Motor terminals act as a seal against this refrigerant. Care should be taken when servicing NOT to damage or loosen motor terminals.

⚠ WARNING

Hazardous Voltage!

Failure to disconnect power before servicing could result in death or serious injury.

Disconnect all electric power, including remote disconnects before servicing. Follow proper lockout/tagout procedures to ensure the power can not be inadvertently energized. Verify that no power is present with a voltmeter.

This section describes the basic chiller preventive maintenance procedures, and recommends the intervals at which these procedures should be performed. Use of a periodic maintenance program is important to ensure the best possible performance and efficiency.

If unit does not operate properly during inspections, see Diagnostics chapter.

Recommended Maintenance

Weekly

While unit is running in stable conditions.

1. At AdaptiView™ TD7 or Tracer® TU service tool, check pressure for evaporator, condenser and intermediate oil.
2. Observe liquid line sight glass on EXV. The refrigerant flow through the sight glasses should be clear. Bubbles

in the refrigerant indicate either low refrigerant charge or excessive pressure drop in the liquid line. A restriction in the line can sometimes be identified by a noticeable temperature differential between the two sides of the restriction. Frost may often form on the liquid line at this point. Correct refrigerant charges are shown in the General Data Tables.

3. Inspect the entire system for unusual operation.
4. Inspect the condenser coils for dirt and debris. If the coils are dirty, see Condenser Coil Cleaning section of Maintenance chapter.

NOTICE

Coil Damage!

Use of detergents could cause damage to coils.

Do not use detergents to clean coils. Use clean water only.

Monthly

1. Perform all weekly maintenance procedures.
2. Record the system subcooling.
3. Record the evaporator superheat.

Annual

1. Perform all weekly and monthly procedures.
2. Check oil level while unit is off. See Maintenance chapter.
3. Have a qualified laboratory perform a compressor oil analysis to determine system moisture content and acid level.
4. Contact a Trane service organization to leak test the chiller, to check operating and safety controls, and to inspect electrical components for deficiencies.
5. Clean all water strainers.

NOTICE

Heater Damage!

Failure to follow instructions below could cause equipment damage.

De-energize evaporator immersion heater and/or any associated evaporator water piping immersion heaters when draining evaporator or evaporator water piping.

6. Clean and repaint any areas that show signs of corrosion.
7. Clean the condenser coils. See Condenser Coil Cleaning section of Maintenance chapter.

NOTICE

Coil Damage!

Use of detergents could cause damage to coils. Do not use detergents to clean coils. Use clean water only.

Refrigerant and Oil Charge Management

Proper oil and refrigerant charge is essential for proper unit operation, unit performance, and environmental protection. Only trained and licensed service personnel should service the chiller.

The following table lists baseline measurements for chillers running at AHRI standard operating conditions. If chiller measurements vary significantly from values listed below, problems may exist with refrigerant and oil charge levels. Contact your local Trane office.

Note: Low temperature applications units will have values that vary from the following table. Contact your local Trane office for more information.

Table 21. Typical baselines (AHRI conditions)

Measurement	Baseline
Evaporator Pressure	115 psia
Evaporator Saturation Temperature	37°F
Evaporator Approach	7°F
EXV Position	53% open
Evaporator DT	10°F
Condenser Pressure	418 psia
Condenser Saturation Temperature	124°F
Subcooling	15°F
Discharge Superheat	82°F
Suction Superheat	11°F
Compressor RLA	95%
Compressor RLA	100%

Lubrication System

Oil Level

Oil should also be visible in the sight glass when the compressor is running. When operating, each compressor in a tandem or trio set may have a different oil level.

To check compressor oil level, refer to the label near the compressor sight glass. The compressor(s) must be off. Wait three minutes. With tandem or triple compressors the oil level will equalize after shutdown. Compressor oil level should be clearly visible within the sight glass when the compressors are off

Important: If oil level is low, contact your local Trane office. Verify that ONLY Trane OIL00080 is used.

Oil Testing

NOTICE

Compressor Damage!

POE oil is hygroscopic – it absorbs water directly from the air. This water is nearly impossible to remove from the compressor oil and can result in compressor failures.

To prevent POE oil from absorbing water, the system should not remain open for longer than necessary. When open, dry nitrogen should flow through the piping. Only new oil containers should be used for service and maintenance. Always use the smallest container size required for the job requirements. Always leave the oil container tightly sealed until time of use. Do not reuse oil that has been opened.

Use Trane Oil Testing Kit KIT06815 only for testing lubricating oil. Note that:

- The POE oil used in this product is very hygroscopic and easily absorbs and retains moisture. The acceptable moisture content is less than 300 ppm and acceptable acid level is less than 0.5 TAN.
- Refrigerant and moisture is very difficult to remove from this oil using vacuum
- Once the seal on a container of POE oil is opened, the oil must be used

Important: In the event of a compressor failure, always test the oil with an acid test kit to determine whether the compressor failure was mechanical or electrical. This information is required to determine the correct cleanup procedure.

Condenser Maintenance

Condenser Coil Cleaning

For information regarding the proper microchannel coil cleaning procedure, see *Coil Cleaning Service Guide* (RTAC-SVG01*-EN) and *Microchannel Coil Servicing Guidelines Service Guide* (RF-SVG001*-EN).

Coil Cleaning Interval

Clean condenser coils at least once a year or more frequently if it is in a "dirty" environment. A clean condenser coil will help maintain chiller operating efficiency.

Cleaning Air Side of Coils

NOTICE

Coil Damage!

Use of coil cleaning agents on uncoated coils could cause damage to coils.

Do not use coil cleaning agents to uncoated clean coils. Use clean water only.

Do not use detergents to clean the air side of coils. Use clean water only. Clean from inside out by removing end panels.

Repair/Replacement of Microchannel Coil

Microchannel coils are considerably more robust in design than tube and fin condenser coils, however they are not indestructible. When damage or a leak occurs, contact your local Trane office.

Condenser Coil Corrosion Protection Inspection

Perform coil inspection each time coils are cleaned.

Inspect corrosion protection at each coil refrigerant connection where the copper tube joins the aluminum manifold. If damaged or missing, wrap new Prestite Insulated tar tape (STR01506) on joint to cover area from the aluminum header body to at least 2 inches of the copper tube. Seal insulation using hand pressure. Rubber gloves are suggested when handling insulation.

Note: *Prestite insulated tar tape is required for all units at each copper/aluminum connection. This requirement is NOT associated with the coated coil option.*

Evaporator Maintenance

This chiller uses a brazed plate heat exchanger (BPHE) evaporator with factory-installed electronic flow switch (IFM effector) that is positioned in the evaporator water pipe. The evaporator inlet also includes a factory-installed immersion heater for freeze protection and a water strainer that must be kept in place to keep debris out of the evaporator.

Note: *Strainer maintenance is critical to proper operation and reliability. Any particles larger than 1mm entering the BPHE evaporator may cause the evaporator to fail, requiring replacement.*

Acceptable BPHE evaporator water flow rate is 1.2 to 3.6 gpm/ton. To maintain 54-44°F in/ out chilled water temperatures, the nominal water flow rate is 2.4 GPM/ton.

Minimum water flow rate must be maintained to avoid laminar flow, potential evaporator freezing, scaling and poor temperature control. The microprocessor and capacity control algorithms are designed to take a 10 percent change in water flow rate per minute while maintaining a $\pm 2^\circ\text{F}$ (1.1°C) leaving water temperature control accuracy.

The chiller tolerates up to 30 percent per minute water flow variation as long as the flow is equal to or greater than minimum flow requirements.

Maximum water flow is 18 feet per second. Flow rates greater than this will cause excessive erosion.

The BPHE evaporator is difficult to clean should it become plugged with debris. Indications of a plugged BPHE evaporator include "wet" suction due to lack of heat exchange, loss of superheat control, depressed discharge superheat, compressor oil dilution and/or starvation and premature compressor failure.

Water Strainer Maintenance

Units without Pump Package

An in-line strainer with a V-shaped sieve is used for units that do not have factory-installed pump package option.

Figure 27. In-line strainer, units without pump package

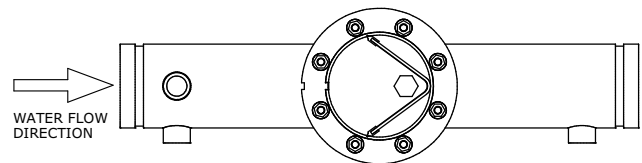

The strainer is equipped with a blow-down port. The strainer is a 16 mesh (approximately 1 mm) material.

For maximum efficiency, a differential pressure gauge installed across the inlet and outlet will indicate pressure loss due to clogging and may be used as a guide to determine when cleaning is required. The taps for the pressure gauges are included as standard from the factory.

Normally when differential pressure reaches 5-10psi, the screen must be cleaned. The strainer is equipped with a blow-down port on the cover plate. To clean open and flush out until any sediment is removed

Units with Pump Package

For units with optional pump package, the factory-installed water strainer is a Y-type design with a cylindrical sieve.

Figure 28. Y-type strainer, units with pump package

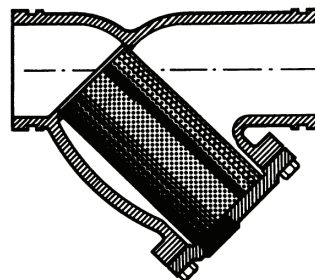

Pump Package Maintenance

Pumps not immediately placed into service, or removed from service and stored, must be properly prepared to prevent excessive rusting.

- Pump port protection plates must not be removed until the pump is ready to connect to the piping.
- Rotate the shaft periodically (at least monthly) to keep rotating element free and bearings fully functional.
- For long term storage (3 months or longer), prevent internal rust buildup and possibility of freezing by performing the following steps:
 - Remove the plugs at the top and bottom of the casing.
 - If water is to be drained:
 - Disconnect evaporator and piping heaters.
 - Drain or blow out all water.
 - As an optional step, it is acceptable to rustproof or pack the casing with moisture absorbing material and cover the flanges.

When returning pumps to service :

- Remove drying agent from the pump, if used.
- Reinstall plugs at the top and bottom of the casing.
- If water had been drained:
 - Refill water.
 - Reconnect evaporator and piping heaters .



Diagnostics

General Diagnostics Information

Diagnostic Name and Source: Diagnostics may be shown in the spec with a source of "xy". In this case, letter "x" can be either "1" or "2" (signifying which circuit) and letter "y" can be "A", "B" or "C" (signifying which compressor on that circuit). Some circuit diagnostics don't have 'x' letter to indicate which circuit is failing. Refer to TD7 alarm display for this information.

Affects Target: Defines the "target" or what is affected by the diagnostic. Usually either the entire Chiller, or a particular Circuit or Compressor is affected by the diagnostic (the same one as the source), but in special cases functions are modified or disabled by the diagnostic. "None" implies that there is no direct affect to the chiller, sub components or functional operation.

Design Note: Functions that are affected by a diagnostic are simply reported as "chiller or circuit x" targets in Tracer® TU and on the Alarms page of the AdaptiView™ display, even though only a specific function and not the entire circuit or chiller would be effected.

Severity: Defines the severity of the above effect. Immediate means immediate shutdown of the affected portion, Normal means normal or friendly shutdown of the affected portion, Special Action means a special action or mode of operation (limp along) is invoked, but without shutdown, and Info means an Informational Note or Warning is generated. Design Note: Tracer TU does not support display of "Special Action", on its Diagnostics pages, so that if a diagnostic has a special action defined in

the table below, it will be displayed only as "Informational Warning" as long as no circuit or chiller shutdown results. If there is a shutdown and special action defined in the table, then the Tracer TU Diagnostics Page display will indicate the shutdown type only.

Persistence: Defines whether or not the diagnostic and its effects are to be manually reset (Latched), or can be either manually or automatically reset when and if the condition returns to normal (Nonlatched).

Active Modes [Inactive Modes]: States the modes or periods of operation that the diagnostic is active in and, as necessary, those modes or periods that it is specifically "not active" in as an exception to the active modes. The inactive modes are enclosed in brackets, []. Note that the modes used in this column are internal and not generally announced to any of the formal mode displays.

Criteria: Quantitatively defines the criteria used in generating the diagnostic and, if nonlatching, the criteria for auto reset.

Reset Level: Defines the lowest level of manual diagnostic reset command which can clear the diagnostic. The manual diagnostic reset levels in order of priority are: Local or Remote. For example, a diagnostic that has a reset level of Remote, can be reset by either a remote diagnostic reset command or by a local diagnostic reset command.

Main Processor Diagnostics

Table 22. Main processor diagnostics

Diagnostic Name	Affects Target	Severity	Persistence	Active Modes [Inactive Modes]	Criteria	Reset Level
Chiller Service Recommended	Chiller	Warning	Latch	Service Messages Enabled	Chiller service interval time has elapsed. Chiller service is recommended.	Remote
Compressor X Fault	Cprsr	Immediate	NonLatch	All	The compressor fault switch input is open.	Local
Compressor Fault Lockout	Cprsr	Immediate	Latch	All	The compressor fault switch input remained open for more than 35 minutes. (Circuit breaker or CMP Protection Module); Five compressor fault diagnostics have occurred within the last 210 minutes.	Local
Emergency Stop Feedback Input	Chiller	Immediate	Latch	All	Emergency Stop input is open.	Local
Energy Meter Write Command Failure	Chiller	Warning	Latch	All	Loss of communication to the Energy Meter during write command process (Controller writes to Energy Meter). Or Energy Meter X's 'Command Status' returns value that is NOT equal to 0 or 3 (0: successful, 3: in Progress). (Only applies to Schneider Energy Meter)	Remote
Energy Meter Write Value Failure	Chiller	Warning	Latch	All	Energy meter failed to return the expected value. (Only applies to Veris Energy Meter)	Remote

Table 22. Main processor diagnostics (continued)

Diagnostic Name	Affects Target	Severity	Persistence	Active Modes [Inactive Modes]	Criteria	Reset Level
Evaporator Pump 1 Fault	Chiller	Immediate or Warning and Special Action	NonLatch	All	For systems with no evaporator pump, a single evaporator pump, or a single inverter driving dual evaporator pumps, an immediate shutdown shall be performed. For multiple pump systems, detection of a pump fault will generally cause pump control to switch to the redundant pump. For single inverter, dual pump configuration, switching to the redundant pump can only happen after the fault is cleared.	Remote
Evaporator Pump 2 Fault	Chiller	Immediate or Warning and Special Action	NonLatch	All	For systems with no evaporator pump, a single evaporator pump, or a single inverter driving dual evaporator pumps, an immediate shutdown shall be performed. For multiple pump systems, detection of a pump fault will generally cause pump control to switch to the redundant pump. For single inverter, dual pump configuration, switching to the redundant pump can only happen after the fault is cleared.	Remote
Evaporator Pump 1 Starts/Hours Modified	Chiller	Warning	NonLatch	All	A counter for evaporator pump 1 starts or hours has been manually modified. This diagnostic is immediately and automatically cleared and thus can only be seen in the historic diagnostic list.	NA
Evaporator Pump 2 Starts/Hours Modified	Chiller	Warning	NonLatch	All	A counter for evaporator pump 2 starts or hours has been manually modified. This diagnostic is immediately and automatically cleared and thus can only be seen in the historic diagnostic list.	NA
Evaporator Water Flow Lost	Chiller	Immediate and Special Action	NonLatch	All	After the pump request was activated, water flow was established and then lost. Special action is to keep the evap pump request active in a diagnostic override mode.	Remote
Evaporator Water Flow Lost Lockout	Chiller	Immediate	Latch	All	Four water flow loss events occurred in a moving 4 day time window. Corrective action is needed to identify and eliminate the cause.	Local
Evaporator Water Flow Lost – Pump 1	Chiller	Warning and Special Action	NonLatch	All	For dual evaporator pump configurations only. Evaporator Water Flow Lost diagnostic occurred while Pump 1 was the selected pump.	Remote
Evaporator Water Flow Lost – Pump 2	Chiller	Warning and Special Action	NonLatch	All	For dual evaporator pump configurations only. Evaporator Water Flow Lost diagnostic occurred while Pump 2 was the selected pump.	Remote
Evaporator Water Flow Overdue	Chiller	Immediate and Special Action	NonLatch	All	After the pump request was activated, the evaporator water flow overdue wait time elapsed before water flow was established. Special action is to keep the evap pump request active in a diagnostic override mode.	Remote
Evaporator Water Flow Overdue – Pump 1	Chiller	Warning and Special Action	NonLatch	All	For dual evaporator pump configurations only. Evaporator Water Flow Overdue diagnostic occurred while Pump 1 was the selected pump.	Remote
Evaporator Water Flow Overdue – Pump 2	Chiller	Warning and Special Action	NonLatch	All	For dual evaporator pump configurations only. Evaporator Water Flow Overdue diagnostic occurred while Pump 2 was the selected pump.	Remote
Evaporator Water Flow Too Low	Chiller	Immediate	Latch	Cooling Mode [Not Cooling Mode]	Refrigerant side to water side heat balance indicates that water flow has dropped below allowable manufacturer limits.	Local
Evap Water Pump 1 Svc Recommended	Chiller	Warning	Latch	Service Messages Enabled	Pump service recommended as service interval hours have elapsed.	Remote
Evap Water Pump 2 Svc Recommended	Chiller	Warning	Latch	Service Messages Enabled	Pump service recommended as service interval hours have elapsed.	Remote
External Chilled/Hot Water Setpoint	Chiller	Warning	NonLatch	All	a. Function Not “Enabled”: no diagnostics. b. “Enabled ”: Out-Of-Range Low or Hi or bad LLID, set diagnostic, default CWS/HWS to next level of priority (e.g. Front Panel SetPoint). This Warning diagnostic will automatically reset if the input returns to the normal range.	Remote
External Demand Limit Setpoint	Chiller	Warning	NonLatch	All	a. Function Not “Enabled”: no diagnostics. b. “Enabled ”: Out-Of-Range Low or Hi or bad LLID, set diagnostic, default DLS to next level of priority (e.g. Front Panel SetPoint). This Warning diagnostic will automatically reset if the input returns to the normal range.	Remote

Diagnostics
Table 22. Main processor diagnostics (continued)

Diagnostic Name	Affects Target	Severity	Persistence	Active Modes [Inactive Modes]	Criteria	Reset Level
High Compressor Pressure Differential	Circuit	Immediate	Latch	Ckt Energized [Ckt Not Energized or Operational Pumpdown]	Compressor involute pressure differential exceeded allowable limits.	Local
High Discharge Refrigerant Pressure	Circuit	Immediate	Latch	All	Discharge pressure exceeded the high pressure cutout setpoint + 100 kPa. Likely cause: failed or incorrectly set high pressure cutout switch. Prevents release of refrigerant through relief valve.	Local
High Discharge Temperature	Circuit	Immediate	NonLatch	Ckt Energized [Ckt Not Energized]	The discharge temperature exceeded the limits for the compressor.	Local
High Discharge Temperature Lockout	Circuit	Immediate	Latch	All	Five high discharge temperature diagnostics occurred over 210 minutes.	
High Evaporator Water Temperature	Chiller	Info and Special Action	NonLatch	Only effective if either 1) Evaporator Water Flow Overdue, 2) Evaporator Water Flow Lost, 3) Low Evap Water Temp: Unit Off, diagnostic is active, 4) Heating mode	Either the leaving or the entering water temperature exceeded the high evap water temp setting (TU service menu settable – default 40.5°C (105°F)) for 15 continuous seconds. The evaporator water pump relay will be de-energized to stop the pump, but only if it is running due to one of the diagnostics listed on the left. The diagnostic will auto reset and the pump will return to normal control when both the entering and leaving falls 2.778°C (5°F) below the trip setting. The primary purpose is to stop the evaporator water pump and its associated pump heat from causing excessive water-side temperatures and water-side pressures when the unit is not running but the evap pump is on due to either Evaporator Water Flow Overdue, Evaporator Water Flow Lost, or Low Evap Water Temp – Unit Off diagnostics. This diagnostic will not auto clear solely due to the clearing of the enabling diagnostic. *At unit installation, especially reversible units, high evap water temp setting will need to be written. The value should be approximately 65.5°C (150°F) for heat pumps	Remote
High Pressure Cutout	Circuit	Immediate	Latch	All	The high pressure cutout switch recognized a high pressure.	Local
High Suction Rfqt Pressure	Chiller	Immediate	NonLatch	All	Any circuit's suction pressure has risen above 95% of the high pressure cutout setting. The evaporator water pump relay will be de-energized to stop the pump regardless of why the pump is running. The diagnostic will auto reset and the pump will return to normal control when all circuits' suction pressures fall below 85% of the high pressure cutout setting. The primary purpose is to stop the evaporator water pump and its associated pump heat from causing refrigerant side pressures close to the relief valve setting when the chiller is not running, such as could occur with Evaporator Water Flow Overdue, Evaporator Water Flow Lost, or Low Evap Water Temp – Unit Off diagnostics. This condition is unlikely unless a discharge isolation valve is installed and closed.	Remote
Inverted Evaporator Water Temperature	Chiller	Warning/Normal	NonLatch/Latch	Any Ckt(s) Energized [No Ckt(s) Energized]	Not Enabled (Default): diagnostic is Non-Latching and Warning. Enabled: diagnostic is Latching and Normal Shutdown. The entering evaporator water temp fell below the leaving evaporator water temperature by more than 3°F for 100° F-sec while at least one compressor was running. Diagnostic will auto clear if the leaving water temp – entering water temp < 3°F. It can warn of improper flow direction through the evaporator, misbound water temperature sensors, improper sensor installation, partially failed sensors, or other system problems. Note that either entering or leaving water temp sensor or the water system could be at fault.	Remote

Table 22. Main processor diagnostics (continued)

Diagnostic Name	Affects Target	Severity	Persistence	Active Modes [Inactive Modes]	Criteria	Reset Level
Inverted Water Temp (Heating)	Chiller	Warning/Normal	NonLatch/Latch	Unit energized and all ckts' reversing valves in heating direction [Unit de-energized or any ckt's reversing valve in cooling direction]	Not Enabled (Default): diagnostic is Non-Latching and Warning. Enabled: diagnostic is Latching and Normal Shutdown. The leaving evaporator water temp fell below the entering evaporator water temperature by more than 3°F for 100° F-sec. There is a 60 second ignore time after the condition to enable the diagnostic is met. During the ignore time, the temperature error is not integrated. Diagnostic will auto clear if the entering water temp – leaving water temp < 3F. It can warn of improper flow direction through the evaporator, misbound water temperature sensors, improper sensor installation, partially failed sensors, or other system problems. Note that either entering or leaving water temp sensor or the water system could be at fault.	Remote
Loss of Charge	Circuit	Immediate	Latch	Ckt Energized [Ckt Not Energized]	This feature is factory enabled for glycol applications only. The diagnostic occurs if the EXV (normal cooling mode only) is consistently and significantly more open than internal models predict for the conditions. This would occur with lack of subcooling from the condenser, a condition that generally suggests undercharging or charge loss. Pressure sensor errors or excessive compressor capacity over the commanded capacity could also cause this diagnostic. (Adjustment is available to mitigate nuisance tripping)	Local
Low Discharge Saturated Temperature	Circuit	Normal	Latch	Ckt Energized [Ckt Not Energized]	The discharge saturated temperature for the respective circuit was below 10 °C for more than 2250 °C-sec, with a 10 minutes ignore time from the start of the circuit. Integration starts after the ignore time is completed.	Local
Low Evaporator Water Temp: Unit On	Chiller	Immediate Shutdown and Special Action	NonLatch	Any Ckt[s] Energzd [No Ckt (s) Energzd]	The evaporator entering or leaving water temp fell below the cutout setpoint for 30° F-seconds while the compressor was running. Automatic reset occurs when both of the temperature rises 2 °F (1.1°C) above the cutout setting for 2 minutes. This diagnostic shall not de-energize the Evaporator Water Pump Output	Remote
Low Evaporator Water Temp: Unit On	Chiller	Immediate Shutdown and Special Action	NonLatch	Any Ckt[s] Energzd [No Ckt (s) Energzd]	The evaporator entering or leaving water temp fell below the cutout setpoint for 30° F-seconds while the compressor was running. Automatic reset occurs when both of the temperature rises 2 °F (1.1°C) above the cutout setting for 2 minutes. This diagnostic shall not de-energize the Evaporator Water Pump Output	Remote
Low Evaporator Water Temp (Unit Off)	Evap Pump and Freeze Avoidance Request Relay	Info and Special Action	NonLatch	Unit in Stop Mode, or in Auto Mode and No Ckt(s) Energzd [Any Ckt Energzd]	Either the entering or leaving evaporator water temp fell below the evaporator water temp cutout setting for 30° F-seconds while the Chiller is in the Stop mode, or in Auto mode with no compressors running. Energize Freeze Avoidance Request Relay and Evap Water Pump Relay until diagnostic auto resets, then de-energize the Freeze Avoidance Request Relay and return to normal evap pump control. Automatic reset occurs when both temps rise 2°F (1.1°C) above the cutout setting for 30 minutes, or either circuit starts. This diagnostic even while active, does not prevent operation of either circuit	Remote
Low Refrigerant Pressure Ratio	Circuit	Normal	Latch	Ckt Energized [Ckt Not Energized]	The refrigerant pressure ratio between compressors outlet and inlet of a given circuit exceeded allowable limits.	Local
Low Refrigerant Temperature	Circuit	Immediate	Latch	Circuit Energized [Service Pumpdown, Operational Pumpdown]	The suction saturated refrigerant temperature dropped below the Low Refrigerant Temperature Cutout Setpoint for 16.67°C-seconds (30°F-seconds).	Local
Low Suction Refrigerant Pressure	Circuit	Immediate	Latch	All	The suction refrigerant pressure fell below the low pressure cutout trip point.	Local

Table 22. Main processor diagnostics (continued)

Diagnostic Name	Affects Target	Severity	Persistence	Active Modes [Inactive Modes]	Criteria	Reset Level
Low Suction Superheat	Circuit	Immediate	Latch	Ckt Energized [Ckt Not Energized]	Measured suction superheat stays below 2.22 °C for one continuous minute in cooling mode or 3 minutes in heating mode, with a 1 minute ignore time from the start of the circuit. Suction Superheat = suction temp – sat. suction temp.	Local
Mfr Maintenance Recommended - xy	Cprsr	Warning	Latch	Service Messages Enabled	Compressor service recommended as service interval hours have elapsed.	Remote
MP: Invalid Configuration	N/A	N/A	Latch	All	MP has an invalid configuration based on the current software installed.	Remote
MP: Reset Has Occurred	Platform	Warning	NonLatch	All	The main processor has successfully come out of a reset and built its application. A reset may have been due to a power up, installing new software or configuration. This diagnostic is immediately and automatically cleared and thus can only be seen in the Historic Diagnostic List in Tracer TU.	Remote
Phase Protection Fault	Chiller	Immediate	NonLatch	All	Phase protection module recognized a phase loss, phase reversal or under/over voltage of the line power. Reset automatically after module recognizes good power for 30 continuous seconds.	Local
Pumpdown Terminated By Time	Circuit	Warning	Latching	Operational/ Service Pumpdown [All Except Operational and Service Pumpdown]	Operational Pumpdown or Service Pumpdown procedure did not terminate normally by reaching the termination pressure within the allotted time.	Remote
Restart Inhibit Invoked - xy	Cprsr	Warning	NonLatch	All	When restart inhibit warning is enabled, the warning exists when unit has been inhibited from starting and is cleared when a start of a compressor is possible (Start-to-Start Timer expires)	Remote
Starts/Hours Modified - xy	Cprsr	Warning	NonLatch	All	A counter for a given compressor starts or hours has been modified by TU. This diagnostic is immediately and automatically cleared and thus can only be seen in the historic diagnostic list.	NA
Suction Temperature Too High	Circuit	Immediate	Latch	Ckt Energized [Ckt Not Energized]	The suction temperature measurement is larger than the entering temperature by more than a threshold value for 5 continuous minutes. The threshold value is 4°C (7.2°F) for cooling-only units, and 20°C for heat pumps. The entering temperature is the evaporator entering water temperature when the reversing valve is in the cooling direction, and the ambient air temperature when the reversing valve is in the heating direction. There is an ignore time of 2 minutes following circuit startup. The trip criteria is not evaluated (and time above the threshold is not counted) until the ignore time passes.	Local
Very Low Suction Pressure – ckt x	Chiller	Immediate	Latch	All	The circuit's suction pressure dropped below (Low Pressure Cutout Setpoint (kPa absolute) * 0.5) regardless of whether or not compressors are running on that circuit. This diagnostic was created to prevent compressor failures due to cross-binding by forcing an entire chiller shutdown.	Local

Sensor Failure Diagnostic

Notes:

1. The following sensor failure diagnostics will not occur unless that input or output is required to be present by the particular configuration and installed options for the chiller.
2. Sensor diagnostics are named by the Functional Name of the input or output that is

no longer sending a valid value to the Main Processor, indicating a sensor failure. Some LLIDs may have more than one functional output associated with it. Refer to the unit's wiring diagrams to relate the occurrence of such sensor failure diagnostics back to the physical LLID boards that they have been assigned to (bound).

Table 23. Sensor failure diagnostics

Diagnostic Name	Affects Target	Severity	Persistence	Active Modes [Inactive Modes]	Criteria	Reset Level
Discharge Pressure Transducer	Circuit	Immediate	Latch	All [Ckt/Cprsr lock out]	Bad Sensor or LLID	Remote
Discharge Temperature Sensor	Circuit	Immediate	Latch	All [Ckt/Cprsr lock out]	Bad Sensor or LLID	Remote
Evaporator Entering Water Temp Sensor	Chiller	Normal	Latch	All	Bad Sensor or LLID.	Remote
Evaporator Leaving Water Temp Sensor	Chiller	Normal	Latch	All	Bad Sensor or LLID	Remote
Liquid Line Pressure Transducer	Circuit	Normal	Latch	All [Ckt/Cprsr lock out]	Bad Sensor or LLID	Remote
Outdoor Air Temp Sensor	Chiller	Normal	Latch	All	Bad Sensor or LLID.	Remote
SLHX Entering Temp Sensor	Circuit	Normal	Latch	All [Ckt lock out]	Bad Sensor or LLID	Remote
Suction Pressure Transducer	Circuit	Immediate	Latch	All [Ckt/Cprsr lock out]	Bad Sensor or LLID	Remote
Suction Temperature Sensor	Circuit	Immediate	Latch	All [Ckt/Cprsr lock out]	Bad Sensor or LLID	Remote

Communication Diagnostics

Notes:

1. The following communication loss diagnostics will not occur unless that input or output is required to be present by the particular configuration and installed options for the chiller.
2. Communication diagnostics (with the exception of "Programmable Annunciation Relay modules) are named by the Functional Name of

the input or output that is no longer being heard from by the Main Processor. Many LLIDs, such as the Quad Relay LLID, have more than one functional output associated with it. A comm loss with such a multiple function board, will generate multiple diagnostics. Refer to the chiller's wiring diagrams to relate the occurrence of multiple communication diagnostics back to the physical LLID boards that they have been assigned to (bound).

Table 24. Communication diagnostics

Diagnostic Name	Affects Target	Severity	Persistence	Active Modes [Inactive Modes]	Criteria	Reset Level
Comm Loss: Auxiliary Setpoint Command	Chiller	Warning and Special Action	Latch	All	Continual loss of communication between the MP and the Functional ID has occurred for a 35-40 second period. Chiller shall discontinue use of the Auxiliary Setpoint and revert to the Chilled Water Setpoint based on setpoint arbitration	Remote
Comm Loss: Compressor Fault Input	Cprsr	Immediate	Latch	All	Continual loss of communication between the MP and the Functional ID has occurred for a 35-40 second period.	Remote
Comm Loss: Condenser Fan Enable	Circuit	Normal	Latch	All	Continual loss of communication between the MP and the Functional ID has occurred for a 35-40 second period.	Remote
Comm Loss: Condenser Fan Enable, Shared Circuit 1&2	Circuit	Warning	Latch	All	Continual loss of communication between the MP and the Functional ID has occurred for a 35-40 second period.	Remote
Comm Loss: Cooling EXV	Circuit	Immediate	Latch	All	Continual loss of communication between the MP and the Functional ID has occurred for a 35-40 second period.	Remote
Comm Loss: Discharge Pressure Transducer	Circuit	Immediate	Latch	All	Continual loss of communication between the MP and the Functional ID has occurred for a 35-40 second period.	Remote
Comm Loss: Discharge Temperature Sensor	Circuit	Immediate	Latch	All	Continual loss of communication between the MP and the Functional ID has occurred for a 35-40 second period.	Remote
Comm Loss: Dynamic Receiver Fill Valve	Circuit	Normal	Latch	All	Continual loss of communication between the MP and the Functional ID has occurred for a 35-40 second period.	Remote
Comm Loss: Electronic Expansion Valve	Circuit	Immediate	Latch	All	Continual loss of communication between the MP and the Functional ID has occurred for a 35-40 second period.	Remote
Comm Loss: Emergency Stop Feedback Input	Chiller	Normal	Latch	All	Continual loss of communication between the MP and the Functional ID has occurred for a 35-40 second period.	Remote
Comm Loss: Energy Meter	Chiller	Warning	Latch	All	Continual loss of communication between the MP and the Power Meter has occurred for a 30 second period.	Remote
Comm Loss: Evap Entering Water Temp	Chiller	Normal	Latch	All	Continual loss of communication between the MP and the Functional ID has occurred for a 35-40 second period.	Remote
Comm Loss: Evap Leaving Water Temp	Chiller	Normal	Latch	All	Continual loss of communication between the MP and the Functional ID has occurred for a 35-40 second period.	Remote
Comm Loss: Evaporator Pump 1 Fault Input	Chiller	Normal	Latch	All	Continual loss of communication between the MP and the Functional ID has occurred for a 35-40 second period.	Remote
Comm Loss: Evaporator Pump 2 Fault Input	Chiller	Normal	Latch	All	Continual loss of communication between the MP and the Functional ID has occurred for a 35-40 second period.	Remote

Table 24. Communication diagnostics (continued)

Diagnostic Name	Affects Target	Severity	Persistence	Active Modes [Inactive Modes]	Criteria	Reset Level
Comm Loss: Evap Pump Inverter 1 Fault Input	Chiller	Warning	Latch	All	Continual loss of communication between the MP and the Functional ID has occurred for a 35-40 second period.	Remote
Comm Loss: Evap Pump Inverter 1 Run Command	Chiller	Normal	Latch	All	Continual loss of communication between the MP and the Functional ID has occurred for a 35-40 second period.	Remote
Comm Loss: Evap Pump Inverter 1 Frequency Feedback	Chiller	Normal	Latch	All	Continual loss of communication between the MP and the Functional ID has occurred for a 35-40 second period.	Remote
Comm Loss: Evap Water Pump Inverter Speed	Chiller	Normal	Latch	All	Continual loss of communication between the MP and the Functional ID has occurred for a 35-40 second period.	
Comm Loss: Evaporator Water Flow Switch	Chiller	Immediate	Latch	All	Continual loss of communication between the MP and the Functional ID has occurred for a 35-40 second period.	Remote
Comm Loss: Evaporator Water Pump 1 Relay	Chiller	Normal	Latch	All	Continual loss of communication between the MP and the Functional ID has occurred for a 35-40 second period.	Remote
Comm Loss: Evaporator Water Pump 2 Relay	Chiller	Normal	Latch	All	Continual loss of communication between the MP and the Functional ID has occurred for a 35-40 second period.	Remote
Comm Loss: External Auto/ Stop	Chiller	Normal	Latch	All	Continual loss of communication between the MP and the Functional ID has occurred for a 35-40 second period.	Remote
Comm Loss: Ext Chilled/Hot Water Setpoint	Chiller	Warning and Special Action	Latch	All	Continual loss of communication between the MP and the Functional ID has occurred for a 35-40 second period. Chiller shall discontinue use of the External Chilled/Hot Water Setpoint source and revert to the next higher priority for setpoint arbitration	Remote
Comm Loss: Ext Demand Limit Setpoint	Chiller	Warning and Special Action	Latch	All	Continual loss of communication between the MP and the Functional ID has occurred for a 35-40 second period. Chiller shall discontinue use of the External Demand Limit Setpoint source and revert to the next higher priority for setpoint arbitration	Remote
Comm Loss: External Ice Building Command	Chiller	Warning	Latch	All	Continual loss of communication between the MP and the Functional ID has occurred for a 35-40 second period. Chiller shall revert to normal (non-ice building) mode regardless of last state.	Remote
Comm Loss: External Hot Water Command	Chiller	Normal	Latch	All	Continual loss of communication between the MP and the Functional ID has occurred for a 35-40 second period.	Remote
Comm Loss: External Noise Reduction Request Input	Chiller	Warning and Special Action	Latch	All	Continual loss of communication between the MP and the Functional ID has occurred for a 35-40 second period. External input is excluded from arbitration logic per standard arbitration rules.	Remote
Comm Loss: Fan Board 1 Relay X	Circuit	Normal	Latch	All	Continual loss of communication between the MP and the Functional ID has occurred for a 35-40 second period.	Remote
Comm Loss: Fan Board 2 Relay X	Circuit	Normal	Latch	All	Continual loss of communication between the MP and the Functional ID has occurred for a 35-40 second period.	
Comm Loss: Fan Inverter Speed Command	Circuit	Normal	Latch	All	Continual loss of communication between the MP and the Functional ID has occurred for a 35-40 second period.	Remote

Table 24. Communication diagnostics (continued)

Diagnostic Name	Affects Target	Severity	Persistence	Active Modes [Inactive Modes]	Criteria	Reset Level
Comm Loss: Fan Inverter Speed Command Shared, Shared Circuit 1&2	Circuit	Warning	Latch	All	Continual loss of communication between the MP and the Functional ID has occurred for a 35-40 second period.	Remote
Comm Loss: Fan Speed Select Board Relay X	Circuit	Normal	Latch	All	Continual loss of communication between the MP and the Functional ID has occurred for a 35-40 second period.	Remote
Comm Loss: Heating EXV	Circuit	Immediate	Latch	All	Continual loss of communication between the MP and the Functional ID has occurred for a 35-40 second period.	Remote
Comm Loss: High Pressure Cutout Switch	Circuit	Immediate	Latch	All	Continual loss of communication between the MP and the Functional ID has occurred for a 35-40 second period.	Remote
Comm Loss: Hot Gas Bypass Valve	Circuit	Normal	Latch	All	Continual loss of communication between the MP and the Functional ID has occurred for a 35-40 second period.	Remote
Comm Loss: Liquid Line Temperature	Circuit	Normal	Latch	All	Continual loss of communication between the MP and the Functional ID has occurred for a 35-40 second period.	Remote
Comm Loss: Liquid Line Pressure	Circuit	Normal	Latch	All	Continual loss of communication between the MP and the Functional ID has occurred for a 35-40 second period.	Remote
Comm Loss: Outdoor Air Temperature	Chiller	Normal	Latch	All	Continual loss of communication between the MP and the Functional ID has occurred for a 35-40 second period.	Remote
Comm Loss: Percent Capacity Output	Chiller	Warning	Latch	All	Continual loss of communication between the MP and the Functional ID has occurred for a 35-40 second period.	Remote
Comm Loss: Phase Protection Fault Input	Chiller	Normal	Latch	All	Continual loss of communication between the MP and the Functional ID has occurred for a 35-40 second period.	Remote
Comm Loss: Programmable Relay Board 1	Chiller	Warning	Latch	All	Continual loss of communication between the MP and the Functional ID has occurred for a 35-40 second period.	Remote
Comm Loss: Programmable Relay Board 2	Chiller	Warning	Latch	All	Continual loss of communication between the MP and the Functional ID has occurred for a 35-40 second period.	Remote
Comm Loss: Reversing Valve	Circuit	Normal	Latch	All	Continual loss of communication between the MP and the Functional ID has occurred for a 35-40 second period.	Remote
Comm Loss: Run Command Compressor X	Cprsr	Immediate	Latch	All	Continual loss of communication between the MP and the Functional ID has occurred for a 35-40 second period.	Remote
Comm Loss: Shared V Coil Isolating Valve	Circuit	Normal	Latch	All	Continual loss of communication between the MP and the Functional ID has occurred for a 35-40 second period.	Remote
Comm Loss: SLHX Valve	Circuit	Normal	Latch	All	Continual loss of communication between the MP and the Functional ID has occurred for a 35-40 second period.	Remote
Comm Loss: SLHX Entering Temperature	Circuit	Normal	Latch	All	Continual loss of communication between the MP and the Functional ID has occurred for a 35-40 second period.	Remote

Table 24. Communication diagnostics (continued)

Diagnostic Name	Affects Target	Severity	Persistence	Active Modes [Inactive Modes]	Criteria	Reset Level
Comm Loss: Suction Pressure Transducer	Circuit	Immediate	Latch	All	Continual loss of communication between the MP and the Functional ID has occurred for a 35-40 second period.	Remote
Comm Loss: Suction Temperature	Circuit	Immediate	Latch	All	Continual loss of communication between the MP and the Functional ID has occurred for a 35-40 second period.	Remote



Unit Wiring

The following table provides a list of electrical schematics, field wiring diagrams and connection diagrams. Wiring diagrams can be accessed via e-Library. A

laminated wiring diagram booklet is also shipped with each unit.

Document Number	Description
2311-5912	Schematic Wiring
Sheet 1	Table of Contents, Notes and Fuse Replacement Table
Sheet 2	Legend; Panel Parts and Designations
Sheet 3	Power Distribution
Sheet 4	Power; Circuit 1 Compressors
Sheet 5	Power; Circuit 2 Compressors
Sheet 6	Controls; Transformers and Power Supplies
Sheet 7	Power; Circuit 1 and 2 Variable Speed Condenser Fans
Sheet 8	Power; Circuit 1 and 2 Fixed Speed Condenser Fans
Sheet 9	Controls; Circuit 1 and 2 Variable Speed Condenser Fans
Sheet 10	Controls; Circuit 1 and 2 Fixed Speed Condenser Fans
Sheet 11	Controls; Circuit 1 and 2 Compressors
Sheet 12	Power and Controls; Pump Package
Sheet 13	Controls; Customer Connections and Heat Pump
Sheet 14	Controls; Unit Sensors and Pump Package
5732-2801	Unit Field Wiring
5732-2802	Field Layout
5732-2803	Component Location — Control Panel
5732-2804	Component Location — Unit



Log and Check Sheets

The following are included for use as appropriate, for installation completion verification before Trane start-up is scheduled, and for reference during the Trane start-up. Where the log or check sheet also exists outside of this publication as standalone literature, the literature order number is also listed.

- *Ascend™ Model ACS and ACX Installation Completion Check Sheet and Request for Trane Service (AC-ADF007*-EN)*
- Operator Log



Ascend™ ACS and ACX Installation Completion Check Sheet and Request for Trane Service

Important: A copy of this completed form must be submitted to the Trane service agency that will be responsible for the start-up of the chiller. Start-up will NOT proceed unless applicable items listed in this form have been satisfactorily completed.

To: _____

Trane Service Office: _____

S.O. Number: _____

Serial Numbers: _____

Job/Project Name: _____

Address: _____

The following items are being installed and will be completed by: _____

Important: Start-up must be performed by Trane or an agent of Trane specifically authorized to perform start-up and warranty of Trane® products. Contractor shall provide Trane (or an agent of Trane specifically authorized to perform start-up) with notice of the scheduled start-up at least two weeks prior to the scheduled start-up.

Important: It is required that heaters are energized for a minimum of 24 hours prior to start-up. Therefore, chiller should have power for this amount of time before Trane Service arrives to do start-up.

Check boxes if the task is complete or if the answer is "yes".

1. Chiller

- Installation meets foundation requirements
- In place and piped
- Isolation pads or elastomeric isolators installed
- Chiller is level to within 1/4-inch end-to-end and side-to-side
- Record and report any damage to the chiller

2. Piping

- Water piping flushed before making final connections to the system
- Chilled water piping connected to:
 - Evaporator
 - Air handling units
 - Pumps (no piping to pump required if optional pump package is installed)
- Strainer installed and cleaned at entering water connection

Note: Do NOT remove chiller strainer mesh to clean the system.

- Verify chilled water inlet vents and chilled water outlet drains are closed or plugs installed
- Water supply connected to filling system
- Does unit have freeze inhibitor? If unit has freeze inhibitor:
 - Verify type and concentration correct per unit submittal
 - Calculate and record freeze point of the solution: _____
- Systems filled
- Pumps run, air bled from system
- Relief valve ventilation piping installed (if applicable)
- Flow balancing valves installed on leaving chilled water
- Gauges, thermometers, and air vents installed on both sides of evaporator

3. Wiring

- Wire size per submittal and NEC 310.15(B)(16)
- Unit is properly grounded
- All wiring connections are tight (not limited to field wiring - include factory wiring and connections)
- Full power available, and within utilization range
- Interconnecting wiring to control panel (as required)
- Chilled water pump connected and tested (not required if optional pump package is installed)
- 115 Vac power available for service tools
- All controls installed and connected

4. Testing

- Trace gas amounts of R-454B available for leak testing, if necessary

5. Refrigerant on job site, if unit shipped with nitrogen charge

- Dry nitrogen available for pressure testing

6. Systems can be operated under load conditions

Important: Start-up cannot be completed without ability to fully load the unit.

7. Heaters

- Verify that the compressor oil sump heaters are installed tightly around the compressor. Energize and verify heaters are operational using a temperature probe.
- If unit was factory charged (model number digit 16 = L), **energize heaters for 24 hours prior to start-up.**

Important: It is required that chiller heaters are energized for a minimum of 24 hours prior to start-up. Therefore, chiller should have power for this amount of time before Trane Service arrives to do start-up.

- If unit has nitrogen charge (model number digit 16 = M), contact Trane Service for unit charging prior to start-up.

8. Owner Awareness

- Does the owner have a copy of the MSDS for refrigerant?

Note: Additional time required to properly complete the start-up and commissioning, due to any incompleteness of the installation, will be invoiced at prevailing rates.

This is to certify that the Trane® equipment has been properly and completely installed, and that the applicable items listed above have been satisfactorily completed.

Important: It is required that the heaters are energized for a minimum of 24 hours prior to start-up. Therefore, the chiller should have power for this amount of time before Trane Service arrives to do start-up of the equipment.

Checklist completed by: _____

Signed: _____

Date: _____

In accordance with your quotation and our purchase order number _____, we will therefore require the presence of Trane service on this site, for the purpose of start-up and commissioning, by _____ (date).

Note: Minimum two-week advance notification is required to allow scheduling of the chiller start-up.

Additional Comments/Instructions:

Note: A copy of this completed form must be submitted to the Trane Service Office that will be responsible for start-up of chiller.



Notes

Trane - by Trane Technologies (NYSE: TT), a global innovator - creates comfortable, energy efficient indoor environments for commercial and residential applications. For more information, please visit trane.com or tranetechnologies.com.

Trane has a policy of continuous product and product data improvements and reserves the right to change design and specifications without notice. We are committed to using environmentally conscious print practices.