



Installation, Operation, and Maintenance

Ascend™ Air-Cooled Chiller

Model ACR Series C

150 to 550 Nominal Tons



573253740003

▲ SAFETY WARNING

Only qualified personnel should install and service the equipment. The installation, starting up, and servicing of heating, ventilating, and air-conditioning equipment can be hazardous and requires specific knowledge and training. Improperly installed, adjusted or altered equipment by an unqualified person could result in death or serious injury. When working on the equipment, observe all precautions in the literature and on the tags, stickers, and labels that are attached to the equipment.

July 2026

AC-SVX003F-EN

TRANE
TECHNOLOGIES™



Introduction

Read this manual thoroughly before operating or servicing this unit.

Warnings, Cautions, and Notices

Safety advisories appear throughout this manual as required. Your personal safety and the proper operation of this machine depend upon the strict observance of these precautions.

The three types of advisories are defined as follows:



Indicates a potentially hazardous situation which, if not avoided, could result in death or serious injury.



Indicates a potentially hazardous situation which, if not avoided, could result in minor or moderate injury. It could also be used to alert against unsafe practices.



Indicates a situation that could result in equipment or property-damage only accidents.

Important Environmental Concerns

Scientific research has shown that certain man-made chemicals can affect the earth's naturally occurring stratospheric ozone layer when released to the atmosphere. In particular, several of the identified chemicals that may affect the ozone layer are refrigerants that contain Chlorine, Fluorine and Carbon (CFCs) and those containing Hydrogen, Chlorine, Fluorine and Carbon (HCFCs). Not all refrigerants containing these compounds have the same potential impact to the environment. Trane advocates the responsible handling of all refrigerants.

Important Responsible Refrigerant Practices

Trane believes that responsible refrigerant practices are important to the environment, our customers, and the air conditioning industry. All technicians who handle refrigerants must be certified according to local rules. For the USA, the Federal Clean Air Act (Section 608) sets forth the requirements for handling, reclaiming, recovering and recycling of certain refrigerants and the equipment that is used in these service procedures. In addition, some states or municipalities may have additional requirements that must also be adhered to for responsible management of refrigerants. Know the applicable laws and follow them.

⚠ WARNING

Proper Field Wiring and Grounding Required!

Failure to follow code could result in death or serious injury.

All field wiring **MUST** be performed by qualified personnel. Improperly installed and grounded field wiring poses **FIRE** and **ELECTROCUTION** hazards. To avoid these hazards, you **MUST** follow requirements for field wiring installation and grounding as described in **NEC** and your local/state/national electrical codes.

⚠ WARNING

Personal Protective Equipment (PPE) Required!

Failure to wear proper PPE for the job being undertaken could result in death or serious injury.

Technicians, in order to protect themselves from potential electrical, mechanical, and chemical hazards, **MUST** follow precautions in this manual and on the tags, stickers, and labels, as well as the instructions below:

- **Before installing/servicing this unit, technicians MUST put on all PPE required for the work being undertaken (Examples; cut resistant gloves/sleeves, butyl gloves, safety glasses, hard hat/bump cap, fall protection, electrical PPE and arc flash clothing). ALWAYS refer to appropriate Safety Data Sheets (SDS) and OSHA guidelines for proper PPE.**
- **When working with or around hazardous chemicals, ALWAYS refer to the appropriate SDS and OSHA/GHS (Global Harmonized System of Classification and Labelling of Chemicals) guidelines for information on allowable personal exposure levels, proper respiratory protection and handling instructions.**
- **If there is a risk of energized electrical contact, arc, or flash, technicians MUST put on all PPE in accordance with OSHA, NFPA 70E, or other country-specific requirements for arc flash protection, PRIOR to servicing the unit. NEVER PERFORM ANY SWITCHING, DISCONNECTING, OR VOLTAGE TESTING WITHOUT PROPER ELECTRICAL PPE AND ARC FLASH CLOTHING. ENSURE ELECTRICAL METERS AND EQUIPMENT ARE PROPERLY RATED FOR INTENDED VOLTAGE.**

⚠ WARNING**Follow EHS Policies!**

Failure to follow instructions below could result in death or serious injury.

- All Trane personnel must follow the company's Environmental, Health and Safety (EHS) policies when performing work such as hot work, electrical, fall protection, lockout/tagout, refrigerant handling, etc. Where local regulations are more stringent than these policies, those regulations supersede these policies.
- Non-Trane personnel should always follow local regulations.

⚠ WARNING**Cancer and Reproductive Harm!**

This product can expose you to chemicals including lead and bisphenol A (BPA), which are known to the State of California to cause cancer and birth defects or other reproductive harm. For more information go to www.P65Warnings.ca.gov.

⚠ WARNING**Refrigerant under High Pressure!**

Failure to follow instructions below could result in an explosion which could result in death or serious injury or equipment damage.

System contains refrigerant under high pressure. Recover refrigerant to relieve pressure before opening the system. See unit nameplate for refrigerant type. Do not use non-approved refrigerants, refrigerant substitutes, or refrigerant additives.

⚠ WARNING**Electrical Shock Hazard!**

Failure to follow instructions below could result in death or serious injury. Properly connect the system's oversized protective earthing (grounding) terminal(s).

Factory Warranty Information

Compliance with the following is required to preserve the factory warranty:

All Unit Installations

Start-up **MUST** be performed by Trane, or an authorized agent of Trane, to **VALIDATE** this WARRANTY. Contractor must provide a two-week start-up notification to Trane (or an agent).

Copyright

This document and the information in it are the property of Trane, and may not be used or reproduced in whole or in part without written permission. Trane reserves the right to revise this publication at any time, and to make changes to its content without obligation to notify any person of such revision or change.

Trademarks

All trademarks referenced in this document are the trademarks of their respective owners.

Factory Training

Factory training is available through Trane University™ to help you learn more about the operation and maintenance of your equipment. To learn about available training opportunities, contact Trane University™.

Online: www.trane.com/traneuniversity

Email: traneuniversity@trane.com

Product Safety Information

This appliance is not intended for use by persons (including children) with reduced physical, sensory or mental capabilities, or lack of experience and knowledge, unless they have been given supervision or instruction concerning use of the appliance by a person responsible for their safety. Children should be supervised to ensure that they do not play with the appliance.

Maximum altitude of use 3000 meters.

This appliance incorporates an earth connection for functional purposes only.

Revision History

- Updated the Long Term Storage Requirements chapter.
- Updated the Dimensions — 375 to 550 ton units without direct-free cooling graphic.
- Added Pump Package Available Head and Net Positive Suction Head Required to the Installation Mechanical chapter.
- Updated Dimensions table for 375 to 550 ton units.
- Added Wind Load and Seismic to digit 36 of the Model Number Descriptions chapter. Added Wind Load and Seismic isolators table to the Installation Mechanical chapter.
- Updated the elastomeric isolator selections table to include Wind Load and Seismic.
- Added pump curves to Pump Package Available Head and Net Positive Suction Head Required section in Installation Mechanical chapter



Table of Contents

Model Number Information	7	Mounting Locations, Weights, Isolators	40
Nameplates	7	Compressor Mounting Bolt Removal	55
Unit Nameplate	7	Drainage	56
Model Number Coding System	7	Refrigerant Pressure Relief Valves	56
Compressor Nameplate	7	Evaporator Piping	56
Model Number Descriptions	8	Evaporator Piping Components	57
Unit Model Number	8	Pump Package	59
Compressor Information	10	Pump Package Available Head and Net Positive Suction Head Required	61
General Information	11	Freeze Protection	67
Unit Length	11	Low Evaporator Refrigerant Cutout, Glycol Requirements	68
Accessory/Option Information	11	Installation Electrical	71
General Data	11	General Recommendations	71
Pre-Installation	16	Units with Nitrogen Charge Option	71
Unit Inspection	16	Installer-Supplied Components	71
Exterior Inspection	16	Power Supply Wiring	72
Inspection for Concealed Damage	16	Adaptive Frequency Drive Capacitor Discharge	75
Repair	16	Control Power Supply	75
Long-Term Storage Requirements	16	Service Power Connection	75
Customer Responsibilities	16	Heater Power Supply	75
Storage Requirements Checklist	16	Chilled Water Pump Control	76
Condensation Prevention	17	Evaporator Pump Package	77
Storage Limitation Disclaimer	17	Evaporator Flow Measurement	77
Handling the Chillers	17	Programmable Relays	77
Installation Requirements	17	Relay Assignments Using Tracer® TU	78
Dimensions and Weights	19	Low Voltage Wiring	78
Weights	19	Emergency Stop	78
Service Clearance	21	External Auto/Stop	78
Unit Dimensions	22	External Circuit Lockout – Circuit #1 and #2	79
Unit Sizes 150 to 330 Tons	22	Ice Building Option	79
Unit Sizes 375 to 550 Tons	33	External Chilled Water Setpoint (ECWS) Option	79
Installation Mechanical	36	External Demand Limit Setpoint (EDLS) Option	80
Location Requirements	36	EDLS and ECWS Analog Input Signal Wiring	80
Sound Considerations	36	Chilled Water Reset (CWR)	81
Foundation	36		
Clearances	36		
Lifting and Moving Instructions	36		
Isolation and Sound Emission	38		
Unit Isolation and Leveling	38		
Elastomeric Isolators	38		

Building Automation Systems	81	Lead Circuit Running — Increasing Load	93
BACnet® Building Automation Control Network	81	Lag Circuit Running — Increasing Load	94
Modbus® Automation Control Network	82	Satisfied Setpoint with Operational Pumpdown	95
LonTalk® Building Automation Systems	82	Full Load to Minimum Load	96
Operating Principles	83	Normal Shutdown to Stopped or Run Inhibit	97
Refrigeration Circuits	83	Immediate Shutdown to Stopped or Run Inhibit	98
Refrigeration Cycle	83	Ice Making (Running to Ice Making to Running)	99
Refrigerant	83	Ice Making (Stopped to Ice to Ice Making Complete)	100
Compressor and Oil System	83	Maintenance	102
Condenser and Fans	83	Recommended Maintenance	102
Evaporator	84	Weekly	102
Free-Cooling Operating Modes	84	Monthly	102
Mechanical Cooling Mode	84	Annual	102
Combined Mechanical and Free-Cooling Mode	84	Refrigerant and Oil Charge Management	103
Free-Cooling Only Mode	84	Lubrication System	103
Controls	85	Oil Sump Level Check	103
Overview	85	Condenser Coil Cleaning	104
Symbio™ 800	85	Coil Cleaning Interval	104
AdaptiView™ Display	85	Cleaning Air Side of Coils	104
Noise Reduction Mode	85	Cleaning Microchannel Coils	104
Tracer® TU	85	Cleaning the Evaporator	105
Integrated Rapid Restart	86	Pump Package	105
Pre-Start	87	Free-Cooling Coil	106
Start-Up and Shutdown	88	Free-Cooling Coil Cleaning	106
Unit Start-Up	88	Free-Cooling Fluid Management	106
Temporary Shutdown and Restart	88	Reinstallation of Compressor Mounting Bolts	106
Extended Shutdown Procedure	88	Servicing Chiller Roof	106
Seasonal Unit Start-Up Procedure	89	Diagnostics	107
System Restart after an Extended Shutdown	89	General Diagnostics Information	107
Sequence of Operation	90	AFD Diagnostics	107
Software Operation Overview	90	Starter Diagnostics	110
Power Up Diagram	90	Main Processor Diagnostics	112
Power Up to Starting	91	Communication Diagnostics	120
Stopped to Starting	92		



Table of Contents

Unit Wiring 125
Log and Check Sheets 128

Ascend™ Model ACR Series C Installation
Completion Check Sheet and Request for
Trane Service 128
Operator Log 129



Model Number Information

Nameplates

Unit nameplates are applied to the exterior of the control panel. A compressor nameplate is located on each compressor. When the unit arrives, compare all nameplate data with ordering, submittal, and shipping information.

Unit Nameplate

The unit nameplate provides the following information:

- Model
- Serial number
- Electrical requirements
- Operating charges (refrigerant and oil)
- Design pressures
- Installation, operation and maintenance and service data literature
- Drawing numbers for unit wiring diagrams

Model Number Coding System

Model numbers are composed of numbers and letters that represent features of the equipment.

Each position, or group of positions, in the model number is used to represent a feature. Unit model number digits are selected and assigned in accordance with the definitions as listed in Model Number Descriptions chapter.

Compressor Nameplate

The compressor nameplate provides the following information:

- Compressor model number
- Compressor serial number
- Compressor electrical characteristics
- Utilization range
- Recommended refrigerant

See Model Number Descriptions chapter for compressor model and serial number descriptions.



Model Number Descriptions

Unit Model Number

Digit 1, 2, 3 — Unit Model

ACR = Air-Cooled Screw Chiller

Digit 4 — Series

C = Series C

Digit 5, 6, 7 — Nominal Tonnage

150 = 150 Tons
165 = 165 Tons
180 = 180 Tons
200 = 200 Tons
225 = 225 Tons
250 = 250 Tons
275 = 275 Tons
300 = 300 Tons
330 = 330 Tons
375 = 375 Tons
380 = 380 Tons
440 = 440 Tons
450 = 450 Tons
500 = 500 Tons
550 = 550 Tons

Digit 8 — Compressor Type

4 = Mixed screw types
5 = GP4 — Screw with Variable Volume Ratio

Digit 9 — Unit Voltage

A = 200/60/3
B = 230/60/3
C = 380/60/3
D = 400/60/3
E = 460/60/3
F = 575/60/3

Digit 10 — Manufacturing Location

U = Trane Commercial Systems,
Pueblo, CO USA
G = Trane Commercial Systems,
Grand Rapids, MI USA

Digits 11, 12 — Design Sequence

** = Factory assigned

Digit 13 — Unit Sound Package

R = InvisiSound™ Standard with Noise Reduction Request
Q = InvisiSound™ Superior with Noise Reduction Request
E = InvisiSound™ Ultimate

Digit 14 — Agency Listing

C = No Agency Listing
E = ETL Listed/Certified to CSA/Conforms to UL

Digit 15 — Pressure Vessel Code

U = ASME Pressure Vessel Code
C = CRN or Canadian Equivalent Pressure Vessel Code

Digit 16 — Factory Charge

E = Refrigerant Charge R-513A
F = Nitrogen Charge, R-513A Field Supplied

Digit 17 — Auxiliary Items

X = No Auxiliary Items

Digit 18 — Evaporator Application

N = Standard Cooling
P = Low Temp Process Cooling
C = Ice Making

Digit 19, 20 — Evaporator Type

C1 = CHIL 1-pass
C2 = CHIL 2-pass
C3 = CHIL 3-pass

Digit 21 — Water Connection

X = Grooved Pipe
A = Grooved Pipe + Flange

Digit 22 — Flow Switch

C = Flow Switch Set Point 15 cm/sec
D = Flow Switch Set Point 25 cm/sec
F = Flow Switch Set Point 35 cm/sec
H = Flow Switch Set Point 45 cm/sec
L = Flow Switch Set Point 60 cm/sec

Digit 23 — Insulation

N = Factory Insulation — All Cold Parts 0.75"
H = Evaporator-only Insulation for High Humidity/
Low Evap Temp 1.25"

Digit 24 — Unit Application

X = Standard Ambient
L = Low Ambient
E = Extreme Low Ambient
H = High Ambient
W = Wide Ambient

Digit 25 — Condenser Length

A = 4V Condenser Coil Modules
B = 5V Condenser Coil Modules
C = 6V Condenser Coil Modules
D = 7V Condenser Coil Modules
E = 8V Condenser Coil Modules
F = 9V Condenser Coil Modules
H = 11V Condenser Coil Modules

Digit 26 — Condenser Fin Options

M = Aluminum Microchannel
C = Coated Microchannel
P = Premium Coated Microchannel

Digit 27 — Fan Type

E = EC Condenser Fan Motors

Digit 28 — Compressor Starter

V = Variable Frequency Drive (1 compressor/
circuit)

Digit 29 — Incoming Unit Power Line Connection

1 = Single Point Power
2 = Dual Point Unit Power Connection
3 = Single Point Power including 115V

Digit 30 — Power Line Connection Type

T = Terminal Block
C = Circuit Breaker
H = Circuit Breaker with High Fault Rated Control Panel

Digit 31 — Short Circuit Current Rating

A = Default Short Circuit Amp Rating
B = High Short Circuit Amp Rating

Digit 32 — Electrical Accessories

N = 20A 115V Convenience Outlet

Digit 33 — Remote Communication Option

X = None
L = LonTalk® Interface
B = BACnet® TP Interface
M = Modbus® Interface
P = BACnet® Interface (IP)

Digit 34 — Hard Wire Communication

X = None
A = Hard Wired Bundle - All
B = Remote Leaving Water Temp Setpoint
C = Remote Leaving Temp and Demand Limit Setpoints
D = Unit Status Programmable Relay
E = Programmable Relay and Leaving Water and Demand Limit Setpoint
F = Percent Capacity
G = Percent Capacity and Leaving Water and Demand Limit Setpoint
H = Percent Capacity and Programmable Relay

Digit 35 — Smart Flow Control

X = None
F = Flow Measurement Factory Installed

Digit 36 — Structural Options

A = Standard Unit Structure
B = Seismic Unit Structure
C = OSHPD Unit Structure
J = Low Level Wind Structure
K = Low Level Wind and Seismic Structure

Digit 37 — Appearance Accessories

X = No Appearance Options
A = Architectural Louvered Panels

Digit 38 — Unit Isolation

X = None
1 = Elastomeric Isolators
4 = Neoprene Pad Isolators

Digit 39 — Shipping Package

X = None
A = Containerization
T = Shipping Tarp Covering Full Unit
B = Containerization and Tarp

Digit 40 — Pump Package

X = None
5 = 50 HP Single Pump High Pressure with Single VFD
6 = 60 HP Single Pump High Pressure with Single VFD
7 = 75 HP Single Pump High Pressure with Single VFD

Digit 41 — Heat Recovery

X = None

Digit 42 — Free-Cooling

X = None
T = Total Direct Free-Cooling
J = Total Direct Free Cooling + 1V Free-Cooling Coils
H = Total Direct Free Cooling + 2V Free-Cooling Coils

Digit 43 — Special

0 = None
S = Special
F = Ship to Final Finisher

Digit 44 — Line Voltage Harmonic Mitigation

X = DC Reactors (~30% TDD)
L = 5% TDD (IEEE519 Compliant)

Digit 45 — Wireless Connectivity

A = Wi-Fi
B = LTE Modem
C = Air-Fi®
D = Wi-Fi and LTE Modem
E = Wi-Fi and Air-Fi®
F = LTE Modem and Air-Fi®
G = Wi-Fi, LTE Modem, and Air-Fi®



Model Number Descriptions

Compressor Information

CHHS MODEL NUMBER (GP4)

Digit 1, 2, 3, 4 — Compressor Type

CHHS = Positive displacement, helical rotary (twin screw) hermetic compressor

Digit 5 — Frame Size

R = R Frame: 70 - 100 tons
S = S Frame: 112 - 165 tons

Digit 6 — Motor Length

B = 145 mm
C = 170 mm
E = 165 mm
F = 190 mm

Digit 7— Motor Winding Characteristics

* = Factory assigned

Digit 8 — Volume Ratio

E = Variable Volume Ratio

Digit 9— Economizer

1 = No Economizer Port

Digits 10, 11 — Design Sequence

** = Factory assigned

CHHW MODEL NUMBER (GP2, GP2.5)

Digit 1, 2, 3, 4 — Compressor Family

CHHW = Positive displacement, helical rotary hermetic compressor

Digit 5 — Economizer Port Detail

0 = No Economizer Port

Digit 6 — Frame Size

N = N Frame

Digit 7— Compressor Capacity

6 = GP2.5 Larger capacity (major)

Digit 8 — Motor Voltage

D = 380/60/3
H = 575/60/3
K = 460 /60/3 (N6 only)
J = 460 /50/3 (N6 only)

Digit 9— Internal Relief

K = 450 psid

Digits 10, 11 — Design Sequence

** = Factory assigned

Digit 12 — Capacity Limit

N = Standard capacity

Digits 13, 14, 15 — Motor kW Rating

112 = N6 50 Hz
134 = N6 60 Hz

Digit 16 — Capacity Limit

A = High Volume Ratio

SERIAL NUMBER

Digit 1, 2 — Year

YY = Last two digits of year of manufacture

Digit 3, 4 — Week

WW = Week of build, from 00 to 52

Digit 5 — Day

1 = Monday
2 = Tuesday
3 = Wednesday
4 = Thursday
5 = Friday
6 = Saturday
7 = Sunday

Digit 6, 7, 8 — Coded Time Stamp

TTT = Used to ensure uniqueness of serial number

Digit 9 — Assembly Line

Assembly line compressor was built on. Varies with facility.

Digit 10 — Build Location

A = Monterrey



General Information

Unit Length

For unit sizes 330 tons and smaller, units are EXTENDED length if either of the following are selected:

- Voltage: 200, 230, 380, 400, or 575V (model number digit 9 = A, B, C, D, or F).
- Harmonic Filtration Option: Filter circuit (model number digit 44 = L).

plugs, electrical diagrams, and service literature, which are placed inside the control panel for shipment.

Optional elastomeric isolators (model number digit 38 = 1) are shipped in the following locations:

- **150 to 330 ton units:** Mounted on diagonal supports on the end of the unit opposite control panel
- **Units larger than 330 tons:** On the horizontal support frame of the chiller

Accessory/Option Information

Verify accessories and loose parts shipped with the unit against the shipping list. Included will be water vessel drain

General Data

Table 1. General data - 150 to 330 ton units

Unit Size (tons)		150	165	180	200	225	250	275	300	330								
Compressor Model		CHHSR	CHHSR	CHHSR	CHHSR	CHHSS	CHHSS	CHHSS	CHHSS	CHHSS								
Quantity	#	2	2	2	2	2	2	2	2	2								
Evaporator																		
Water Storage	gal	17.5	18.7	21.9	23.9	26.6	28.7	33.0	36	37.9								
	L	66.1	70.9	82.8	90.5	100.6	108.8	125.0	136.1	143.3								
Max. Water Temperature	°F	120	120	120	120	120	120	120	120	120								
	°C	48.9	48.9	48.9	48.9	48.9	48.9	48.9	48.9	48.9								
Min. Water Pressure	psig	0	0	0	0	0	0	0	0	0								
	kPa	0	0	0	0	0	0	0	0	0								
Max. Water Pressure	psig	150	150	150	150	150	150	150	150	150								
	kPa	1034.2	1034.2	1034.2	1034.2	1034.2	1034.2	1034.2	1034.2	1034.2								
2 Pass arrangement																		
Evap Water Connection Size ^(a)	in	5	5	6	6	6	6	8	8	8								
	mm	125	125	150	150	150	150	200	200	200								
Minimum Flow ^(b)	gpm	171	187	202	228	261	288	318	354	378								
	l/s	10.8	11.8	12.7	14.4	16.5	18.2	20.1	22.3	23.8								
Maximum Flow ^(b)	gpm	626	684	742	835	957	1055	1165	1299	1386								
	l/s	39.5	43.1	46.8	52.7	60.4	66.5	73.5	81.9	87.4								
3 Pass arrangement																		
Evap Water Connection Size ^(a)	in	4	4	5	5	5	5	6	6	6								
	mm	100	100	125	125	125	125	150	150	150								
Minimum Flow ^(b)	gpm	114	124	135	152	174	192	212	236	252								
	l/s	7.2	7.8	8.5	9.6	11.0	12.1	13.4	14.9	15.9								
Maximum Flow ^(b)	gpm	417	456	495	557	638	703	777	866	924								
	l/s	26.3	28.8	31.2	35.1	40.2	44.3	49.0	54.6	58.3								
Condenser																		
Length - Model Number Digit 25 ^(c)		A	A	B	A	B	B	C	B	C	B	C	C	D	D	E	E	F
Quantity of Coil Modules		8	8	10	8	10	10	12	10	12	10	12	12	14	14	16	16	18
Quantity of Fans		8	8	10	8	10	10	12	10	12	10	12	12	14	14	16	16	18
Fan Diameter	in	37.5																
	mm	953																



General Information

Table 1. General data - 150 to 330 ton units (continued)

Unit Size (tons)		150	165	180	200	225	250	275	300	330								
Coil Length	in	78																
	mm	1987																
Coil Height	in	49																
	mm	1252																
Fins/Ft		276																
Ambient Temperature Range																		
Standard Ambient	°F (°C)	32 to 105 (0 to 40.6)																
Low Ambient	°F (°C)	0 to 105 (-17.7 to 40.6)																
Extreme Low Ambient	°F (°C)	-20 to 105 (-28.9 to 40.6)																
High Ambient	°F (°C)	32 to 125 (0 to 52)																
Wide Ambient	°F (°C)	0 to 125 (-17.7 to 52)																
General Unit																		
Refrigerant		R-513A																
Refrigerant Ckts	#	2																
Minimum Load	%	20	18	18	17	17	15	15	20	20	18	18	16	16	15	15	14	14
Refrigerant Charge/ckt	lb	170	165	195	176	205	197	225	204	231	194	220	229	254	240	263	248	270
	kg	77	75	89	80	93	89	102	92	105	88	100	104	115	109	119	112	122
Oil		OIL00386																
Oil Charge/ckt	gal	2.7	2.7	2.7	2.7	2.7	2.7	2.7	3.5	3.5	3.5	3.5	3.5	3.5	3.5	3.5	3.5	3.5
	L	10.2	10.2	10.2	10.2	10.2	10.2	10.2	13.2	13.2	13.2	13.2	13.2	13.2	13.2	13.2	13.2	13.2
Relief Valves																		
		High Side																
Relief setting	psig	350																
Rated Capacity	lba/min	29.5																
Quantity per unit		2																
Factory connection		3/8 NPT																
Field Connection		5/8 MFL																
		Low Side																
Relief setting	psig	200																
Rated Capacity	lba/min	28.9																
Quantity per unit		2																
Factory connection		7/8 UNF-2A																
Field Connection		3/4 NPTF																

(a) Inlet and outlet sizing changes with options. Free cooling pipe sizes override evaporator sizes and pumps sizes override all options.

(b) Minimum and maximum flow rates apply to constant-flow chilled water systems running at AHRI conditions, without freeze inhibitors added to the water loop.

(c) Condenser length defined by model number digit 25: A = 4V; B = 5V; C = 6V; D = 7V; E = 8V; F = 9V.

Table 2. General data - 375 to 550 ton units

Unit Size (tons)		375		380		440		450		500		550	
Circuit ^(a)		1	2	1	2	1	2	1	2	1	2	1	2
Compressor Model	Comp A	CHHSS	CHHSS	CHHSS	CHHSS	CHHSS	CHHSS	CHHSS	CHHSS	CHHSS	CHHSS	CHHSS	CHHSS
	Comp B	N6	—	N6	—	N6	—	N6	—	N6	N6	N6	N6
Evaporator													
Water Storage	gal	36.3		36.3		39.5		39.5		45.0		49.3	
	L	137.3		137.3		149.6		149.6		170.3		186.8	

Table 2. General data - 375 to 550 ton units (continued)

Unit Size (tons)		375		380		440		450		500		550	
Circuit ^(a)		1	2	1	2	1	2	1	2	1	2	1	2
Max. Water Temperature	°F	120		120		120		120		120		120	
	°C	48.9		48.9		48.9		48.9		48.9		48.9	
Min. Water Pressure	psig	0		0		0		0		0		0	
	kPa	0		0		0		0		0		0	
Max. Water Pressure	psig	150		150		150		150		150		150	
	kPa	1034.2		1034.2		1034.2		1034.2		1034.2		1034.2	
1 Pass Arrangement													
Evap Water Connection Size ^(b)	in	8		8		8		8		8		8	
	mm	200		200		200		200		200		200	
Minimum Flow ^(e)	gpm	398		398		398		450		523		591	
	l/s	25.1		25.1		25.1		28.4		33.0		37.3	
Maximum Flow ^(e)	gpm	1750		1750		1750		1981		2303		2603	
	l/s	110.4		110.4		110.4		125.0		145.3		164.2	
2 Pass Arrangement													
Evap Water Connection Size ^(b)	in	8		8		8		8		8		8	
	mm	200		200		200		200		200		200	
Minimum Flow ^(e)	gpm	198		198		198		224		260		294	
	l/s	12.5		L		12.5		14		16.4		18.5	
Maximum Flow ^(e)	gpm	871		871		871		986		1146		1295	
	l/s	55.0		55.0		55.0		62.2		72.3		81.7	
Condenser													
Length - Model Number Digit 25 ^(d)		F		H		F		H		H		H	
Quantity of Coil Modules		12	6	14	8	12	6	14	8	12	10	12	10
Quantity of Fans	#	12	6	14	8	12	6	14	8	12	10	12	10
Fan Diameter	in	37.5											
	mm	953											
Coil Length	in	78.22											
	mm	1987											
Coil Height	in	49.31											
	mm	1252											
Fins/Ft		276											
Ambient Temperature Range													
Standard Ambient	°F (°C)	32 to 105 (0 to 40.6)											
Low Ambient	°F (°C)	0 to 105 (-17.7 to 40.6)											
Extreme Low Ambient	°F (°C)	-20 to 105 (-28.9 to 40.6)											
High Ambient	°F (°C)	32 to 125 (0 to 52)											
Wide Ambient	°F (°C)	0 to 125 (-17.7 to 52)											
General Unit													
Refrigerant		R-513A											
Refrigerant Ckts	#	2											
Minimum Load	%	15		15		15		15		10		10	
Refrigerant Charge/ckt	lb	366	177	405	215	366	177	405	215	380	365	380	365
	kg	166	80	184	98	166	80	184	98	172	166	172	166



General Information

Table 2. General data - 375 to 550 ton units (continued)

Unit Size (tons)		375		380		440		450		500		550	
Circuit ^(a)		1	2	1	2	1	2	1	2	1	2	1	2
Oil		OIL00386											
Oil Charge/ckt	gal	4.8	3.5	4.8	3.5	4.8	3.5	4.8	3.5	4.8	4.8	4.8	4.8
	L	18.2	13.2	18.2	13.2	18.2	13.2	18.2	13.2	18.2	18.2	18.2	18.2
Relief Valves													
High Side													
Relief setting	psig	350											
Rated Capacity	lba/min	29.5											
Quantity per unit		2											
Factory connection		3/8 NPT											
Field Connection		5/8 MFL											
Low Side													
Relief setting	psig	200											
Rated Capacity	lba/min	28.9											
Quantity per unit		2											
Factory connection		7/8 UNF-2A											
Field Connection		3/4 NPTF											

^(a) Circuit applicable where two values given per tonnage.

^(b) Inlet and outlet sizing changes with options. Free cooling pipe sizes override evaporator sizes and pumps sizes override all options.

^(c) Minimum and maximum flow rates apply to constant-flow chilled water systems running at AHRI conditions, without freeze inhibitors added to the water loop.

^(d) Condenser length defined by model number digit 25: F = 9V; H = 11V.

Table 3. General data - free cooling specific data

Description	Units	Values																
		B			C			D			E			F				
Condenser Length - Model Number Digit 25 ^(a)														H				
Free-Cooling Model Number Digit 42 ^(b)		T	J	H	T	J	H	T	J	H	T	J	H	T	J	H	T	
Customer Water Connection Size ^(c)	in	6												8				
	mm	152												200				
Quantity of Free-Cooling Coils (Extended)		9 (10)	11 (12)	13 (14)	15 (16)	17 (18)	19 (20)	21 (22)	23 (24)	25 (26)	27 (28)	29 (30)	31 (32)	33 (34)	35 (36)	37 (38)	39 (40)	
Quantity of Free-Cooling-only fans		—	2	4	—	2	4	—	2	4	—	2	4	—	2	4	—	
Coil Length	in	72.49																
	mm	1841																
Coil Height	in	40																
	mm	1016																
Fins/Ft		192																
Rows		3																
Free Cooling Customer Side Storage Volume (Extended Length)	gal	123 (129)	145 (151)	173 (179)	212 (218)	234 (240)	212 (218)	234 (240)	212 (218)	234 (240)	212 (218)	234 (240)	212 (218)	234 (240)	212 (218)	234 (240)	212 (218)	234 (240)
	L	467 (489)	550 (572)	656 (679)	801 (823)	883 (906)	801 (823)	883 (906)	801 (823)	883 (906)	801 (823)	883 (906)	801 (823)	883 (906)	801 (823)	883 (906)	801 (823)	883 (906)
Pump Package																		
Pump Package Option - Model Number Digit 40 ^(d)																		
Pump HP																		
Customer Water Connection Size ^(c)	in	—																
	mm																	
Additional Water Storage in Pump System	gal																	
	L																	

(a) Condenser length defined by model number digit 25: B = 5V; C = 6V; D = 7V; E = 8V; F = 9V; H = 11V.

(b) Direct Free-Cooling defined by model number digit 42: T = TDFC; J = DFC1; H = DFC2.

(c) Inlet and outlet sizing changes with options. Free cooling pipe sizes override evaporator sizes and pumps sizes override all options.

(d) Pump Package defined by model number digit 40: 5 = SV50, 6 = SV60, 7 = SV75.



Pre-Installation

Unit Inspection

To protect against loss due to damage incurred in transit, perform inspection immediately upon receipt of the unit.

Exterior Inspection

If the job site inspection reveals damage or material shortages, file a claim with the carrier immediately. Specify the type and extent of the damage on the bill of lading before signing. Notify the appropriate sales representative.

Important: Do not proceed with installation of a damaged unit without sales representative's approval.

- Visually inspect the complete exterior for signs of shipping damages to unit or packing material.
- Verify that the nameplate data matches the sales order and bill of lading.
- Verify that the unit is properly equipped and there are no material shortages.

Note: Corrosion due to dirt, road grime, road salt, and other contaminants picked up during shipping is not the responsibility of the carrier.

Inspection for Concealed Damage

Visually inspect the components for concealed damage as soon as possible after delivery and before it is stored.

If concealed damage is discovered:

- Notify the carrier's terminal of the damage immediately by phone and by mail.
- Concealed damage must be reported within 15 days.
- Request an immediate, joint inspection of the damage with the carrier and consignee.
- Stop unpacking the unit.
- Do not remove damaged material from receiving location.
- Take photos of the damage, if possible.
- The owner must provide reasonable evidence that the damage did not occur after delivery.

Repair

Notify the appropriate sales representative before arranging unit installation or repair.

Important: Do not repair unit until the damage has been inspected by the carrier's representative.

Long-Term Storage Requirements

Proper preparation and storage of Trane chillers during extended inactivity helps prevent damage or deterioration and supports efficient operation after installation.

If air-cooled chillers are stored under cover, use only the tarp provided by Trane. Do not use shrink wrap unless specific measures are in place to control condensation. Place units on wooden blocks on level gravel, asphalt, or concrete surfaces. Avoid exposure to standing water.

Customer Responsibilities

The customer must inspect the unit upon receipt. If the tarp shows visible damage, remove it and inspect the unit further. Re-cover the unit with a tarp after inspection.

Any damage found during the initial inspection must be reported to Trane within 72 hours of discovery. Failure to report damage within that time may result in denial of the claim by Trane.

Visible damage must be noted on the signed and dated bill of lading. The customer may request a carrier inspection by phone or in person, but the request should be confirmed in writing. It is recommended that the customer ask the carrier to inspect the damage within 72 hours of notification.

If the tarp is damaged while the unit is in storage, it must be repaired or replaced before further transportation.

Storage Requirements Checklist

Check boxes if the task is complete or if the answer is **yes**.

1. Upon Arrival

- Inspect the tarp for visible damage (if applicable).
- Remove tarp for internal inspection, if damaged.
- Note visible damage to the signed and dated bill of lading.
- Report damage to Trane within 72 hours of discovery.

2. Storage Location

- Store the outdoor unit in a secure area.
- Confirm solid, flat foundation (gravel or asphalt or concrete).
- Place unit on wood blocks under outside rails at locations near or adjacent to unit mounting locations (blocks must be at least 4 inches wide).
- Confirm the ground where the chiller is placed is dry.
- Confirm temperature range: -40°F to 145°F (-40°C to 63°C).
- Inspect the unit for rust, corrosion, or moisture accumulation inside the control panel.
- Confirm the storage area is free of standing water.

3. Storage Environment and Pest Management

- Check for pest intrusion, nesting, or damage.
- Remove surrounding vegetation and sheltering materials.

- Inspect for rodent activity: droppings, nesting, or gnaw marks.
- Maintain cleanliness by clearing debris and clutter.
- Apply deterrents: traps, repellents, or professional pest control services.

4. Component Readiness – Fans and Electronics

- Inspect power electronics for oxidation or condensation.
- Verify covers and cable glands are properly secured.
- Seal gaps around mains power conduit at input plate.

5. After Inspection

- Cover the chiller with the tarp (if removal was necessary).

6. Pre-Start Up

- Refer to the IOM for details.

Note: Upon request, documentation will be required to demonstrate compliance with the recommended storage procedures and checklist

Condensation Prevention

For long-term pre-storage preparation exceeding 180 days, Trane recommends the following best practices to reduce condensation and environmental exposure during outdoor storage:

- Avoid wraps that can trap moisture and accelerate corrosion.
- Completely drain all water from the unit and verify that all internal components are thoroughly dry.

In regions with high humidity, increased airflow and moisture control under the cover are especially important to protect chiller integrity.

Storage Limitation Disclaimer

Storage of chillers beyond 730 days from the date of manufacture is not recommended or supported.

Type	Trane Supplied Trane Installed	Trane Supplied Field Installed	Field Supplied Field Installed
Foundation	—	—	• Meet foundation requirements
Rigging	—	—	• Safety chains • Clevis connectors • Lifting beam • Spreader bar
Disassembly/Reassembly (as required)	Trane, or an agent of Trane specifically authorized to perform start-up of Trane® products (contact your local Trane office for pricing)	—	—
Isolation	—	Elastomeric isolators (optional)	• Elastomeric isolators (optional)

All storage requirements must be followed to protect chiller integrity and performance.

For best performance, chillers should be installed and operating within the 730-day period.

Handling the Chillers

Factory packaging allows the chiller to be lifted with a suitable crane. Use straps that are in good condition and rated for the unit weight. Spreader bars may be needed for proper rigging and to prevent damage to the chiller.

The chiller is shipped fully charged with either N2 or refrigerant. Start-up and service must be performed by fully qualified, factory-certified personnel.

For units charged with refrigerant, verify that the following valves are closed on each circuit:

- Suction service valve (butterfly valve)
- Liquid line angle valve or EXV (the EXV is driven closed whenever the circuit is powered)
- Oil line shutoff valves to brazed plate heat exchangers

Units with factory refrigerant charge (model number digit 16) are shipped with the suction, liquid, and oil line shutoff valves closed, isolating most of the refrigerant charge in the evaporator. If the unit will go directly into long-term storage, confirm these valve positions.

Units with the nitrogen charge option (model number digit 16) are shipped with the valves open. If the unit will go directly into storage before refrigerant charging, confirm that all service valves are open.

Check the pressure in the refrigerant circuits at least every three months to verify that the refrigerant charge remains intact. If it does not, contact a qualified service organization and the appropriate Trane sales office.

Installation Requirements



Pre-Installation

Type	Trane Supplied Trane Installed	Trane Supplied Field Installed	Field Supplied Field Installed
Electrical	<ul style="list-style-type: none"> • Circuit breakers (optional) • Unit Mounted Starter 	—	<ul style="list-style-type: none"> • Circuit breakers (optional) • Electrical connections to unit mounted starter • Wiring sizes per submittal and NEC • Terminal lugs • Ground connection(s) • Ground type specified (Center Ground-Y or not) • BAS wiring (optional) • Control voltage wiring • Chilled water pump contactor and wiring • Option relays and wiring
Water piping	Flow switch	—	<ul style="list-style-type: none"> • Taps for thermometers and gauges • Thermometers • Water flow pressure gauges • Isolation and balancing valves in water piping • Vents and drain • Waterside pressure relief valves • Water strainer
Insulation	Insulation		Insulation
Water Piping Connection Components	Grooved pipe	Flange kit (optional)	—
Other Materials	<ul style="list-style-type: none"> • R-513A refrigerant • Dry nitrogen (optional) 	—	—
Installation Completion Check Sheet and Request for Trane Service Ascend™ Model ACR Series C (AC-ADF005*-EN) See Log and Check Sheet chapter	—	—	—
Chiller Start-up Commissioning	Trane, or an agent of Trane specifically authorized to perform start-up of Trane® products	—	—
Trane specifically authorized to perform start-up of Trane® products	—	—	—



Dimensions and Weights

Weights

Table 4. Weights — 150 to 330 ton units

Unit Size (tons)	Condenser Length ^(a)	Free Cooling Option ^(b)	Pump Option ^(c)	Standard Length				Extended Length ^(d)			
				Shipping		Operating		Shipping		Operating	
				lb	kg	lb	kg	lb	kg	lb	kg
150	4V	—	—	12000	5450	12200	5540	14200	6450	14400	6540
165	4V	—	—	12100	5490	12300	5580	14300	6490	14500	6580
	5V	—	—	13100	5950	13200	5990	15200	6900	15400	6990
	5V	TDFC	—	16000	7260	17200	7810	18600	8440	20000	9080
	5V	DFC1	—	17300	7830	19100	8670	20000	9040	21800	9880
180	5V	DFC2	—	18100	8190	20000	9030	20800	9400	22600	10240
	4V	—	—	12200	5540	12400	5630	14600	6630	14800	6720
	5V	—	—	13400	6080	13500	6130	15500	7040	15700	7130
	5V	TDFC	—	16800	7630	18000	8170	18800	8550	20300	9210
	5V	DFC1	—	17800	8040	19600	8890	20200	9160	22100	10000
200	5V	DFC2	—	19200	8680	21000	9530	21000	9530	22900	10380
	5V	—	—	13600	6170	13800	6260	15600	7080	15800	7170
	6V	—	—	14600	6630	14800	6720	16600	7530	16800	7630
	6V	TDFC	—	18600	8440	20000	9080	20900	9490	22400	10170
	6V	DFC1	—	20400	9220	22400	10160	22900	10370	25000	11310
225	6V	DFC2	—	21500	9740	23600	10690	22400	10140	26200	11870
	5V	—	—	14800	6720	15000	6810	17000	7720	17200	7810
	6V	—	—	15900	7220	16100	7310	18100	8220	18300	8310
	6V	TDFC	—	19900	9030	21300	9670	22300	10120	23800	10800
	6V	DFC1	—	20700	9360	22800	10310	23200	10510	25300	11460
250	6V	DFC2	—	21800	9850	23900	10800	24500	11070	26600	12050
	5V	—	—	14900	6760	15100	6850	17300	7850	17500	7940
	6V	—	—	16300	7400	16500	7490	18400	8350	18700	8490
	6V	TDFC	—	20300	9210	21700	9850	22500	10210	24200	10980
	6V	DFC1	—	20800	9440	22900	10390	23300	10530	25400	11490
275	6V	DFC2	—	20900	9480	24000	10890	24600	11160	26700	12080
	6V	—	—	16500	7490	16700	7580	18500	8400	18800	8530
	6V	TDFC	—	20400	9260	21800	9860	22600	10260	24500	11080
	7V	—	—	17400	7900	17700	8030	19600	8900	19800	8990
	7V	TDFC	—	21700	9850	23800	10780	24400	11070	26400	11980
	7V	DFC1	—	22800	10330	24900	11290	25300	11450	27500	12440
	7V	DFC1	PUMP	27000	12220	30700	13910	29400	13340	33200	15060
	7V	DFC2	—	23900	10830	26200	11870	26100	11830	28400	12880
7V	DFC2	PUMP	28100	12720	32000	14490	30300	13720	34200	15500	



Dimensions and Weights

Table 4. Weights — 150 to 330 ton units (continued)

Unit Size (tons)	Condenser Length ^(a)	Free Cooling Option ^(b)	Pump Option ^(c)	Standard Length				Extended Length ^(d)			
				Shipping		Operating		Shipping		Operating	
				lb	kg	lb	kg	lb	kg	lb	kg
300	7V	—	—	17500	7940	17700	8030	19700	8900	19900	9030
	7V	TDFC	—	21800	9890	23900	10840	24500	11040	26500	11990
	8V	—	—	18500	8400	18800	8530	20700	9390	20900	9490
	8V	TDFC	—	23400	10590	25500	11620	25800	11670	27900	12660
	8V	TDFC	PUMP	27600	12470	31300	14180	29800	13520	33500	15180
	8V	DFC1	—	24700	11180	27000	12210	26900	12180	29300	13260
	8V	DFC1	PUMP	28800	13070	32800	14850	31100	14070	35100	15890
	8V	DFC2	—	25600	11600	28200	12790	27800	12540	30400	13790
330	8V	—	—	19100	8650	19500	8830	21400	9680	21800	9870
	8V	TDFC	NONE	23800	10780	26000	11780	26300	11920	28600	12940
	8V	TDFC	PUMP	28000	12670	31800	14410	30500	13800	34400	15570
	9V	—	NONE	20300	9200	20800	9400	22300	10100	22700	10280
	9V	TDFC	NONE	25500	11570	27900	12630	27700	12570	30100	13650
	9V	TDFC	PUMP	29700	13450	33700	15270	31900	14450	35900	16270
	9V	DFC1	—	26200	11870	28700	12980	27900	12640	30500	13830
	9V	DFC1	PUMP	30400	13760	34400	15610	32100	14530	36100	16350

Notes:

- Weights include factory charge of refrigerant and oil, ultimate sounds, and architectural louvered panels.
- All weights are plus/minus 10%

^(a) Condenser length defined by model number digit 25: 4V = A; 5V = B; 6V = C; 7V = D; 8V = E; 9V = F

^(b) Direct Free Cooling defined by model number digit 42: T=TDFC; J=DFC1; H=DFC2.

^(c) Pump Package defined by model number digit 40 = 5, 6, 7

^(d) Extended Length is required for voltages 200V, 230V, 380V, 400V, 575V (model number digit 9 = A, B, C, D, F), and harmonic filtration model number digit 44 = L.

Table 5. Weights — 375 to 550 ton units

Unit Size (tons)	Condenser Length ^(a)	Standard Unit with SPP ^(b)				Std Unit with SPP and Options Box ^(c)			
		Shipping		Operating		Shipping		Operating	
		lb	kg	lb	kg	lb	kg	lb	kg
Units without Direct Free-Cooling ^(d)									
375	9V	22900	10390	23300	10570	25500	11570	25900	11750
440	9V	22900	10390	23300	10570	25500	11570	25900	11750
380	11V	25200	11440	25500	11570	27200	12340	27600	12520
450	11V	25200	11440	25500	11570	27200	12340	27600	12520
500	11V	27400	12430	27900	12660	29500	13390	29900	13570
550	11V	27400	12430	27900	12660	29500	13390	29900	13570
Units with Direct Free-Cooling ^(d)									
380	11V	30900	14020	33200	15060	33400	15150	35500	16100
450	11V	30900	14020	33200	15060	33400	15150	35500	16100
500	11V	33100	15020	35500	16100	35200	15600	37600	17060
550	11V	33100	15020	35500	16100	35200	15600	37600	17060

Notes:

- Weights include factory charge of refrigerant and oil, architectural louvered panels, and Superior sound option.
- All weights are plus/minus 10%.

^(a) Condenser length defined by model number digit 25: 9V = F; 11V = H.

^(b) Single Point Power (SPP) is indicated by model number digit 29 = 1.

^(c) Options box is used for units with either 575V (model number digit 9 = F) or Low Harmonics Option (model number digit 44 = L).

^(d) Direct Free-Cooling defined by model number digit 42 = T.

Service Clearance

Figure 1. Unit service clearance requirements — 150 to 330 ton units

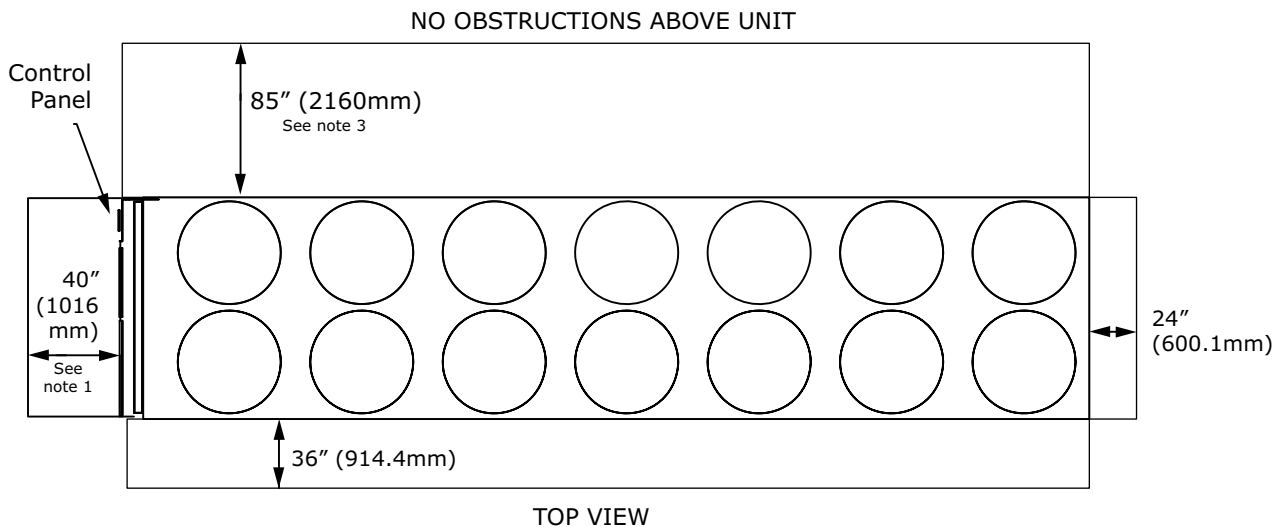
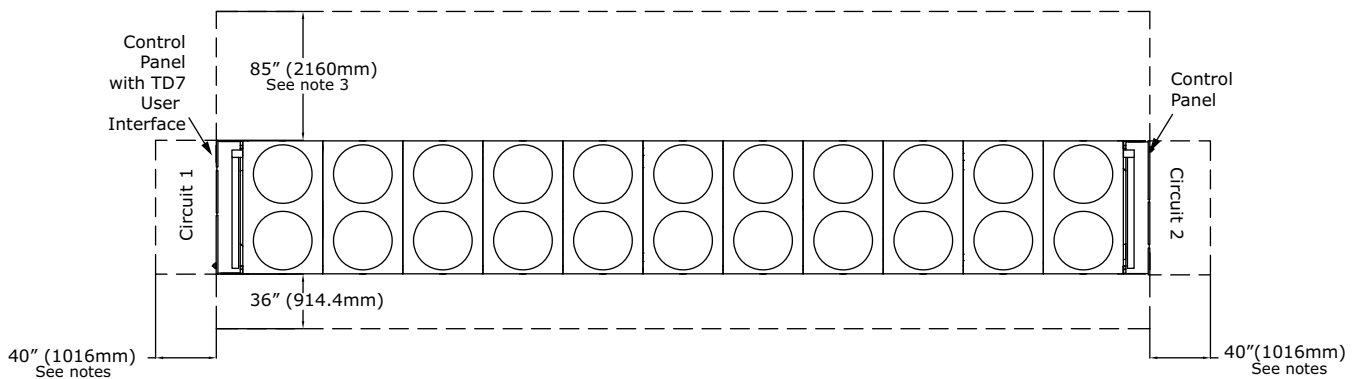

Figure 2. Unit service clearance requirements — 375 to 550 ton units



Notes:

1. A full 40" clearance is required in front of the control panel(s). Must be measured from front of panel, not end of unit base. Installer must also follow NEC and local/state codes for electrical clearance requirements.
2. Area above unit is required for operation, maintenance, access panel and air flow. No obstructions above unit.
3. Clearance of 85" on the side of the unit is required for coil replacement. Preferred side for coil replacement is shown (left side of the unit, as facing control panel), however either side is acceptable.
4. For obstructions or multiple units, refer to *Close-Spacing and Restricted Airflow Situations, Ascend™ Chiller Models ACR and ACS, Sintesis™ Chiller Model RTAF Engineering Bulletin (AC-PRB001*-EN)*.



Dimensions and Weights

Unit Dimensions

Unit Sizes 150 to 330 Tons

Figure 3. Dimensions — 150 to 330 ton units, standard length

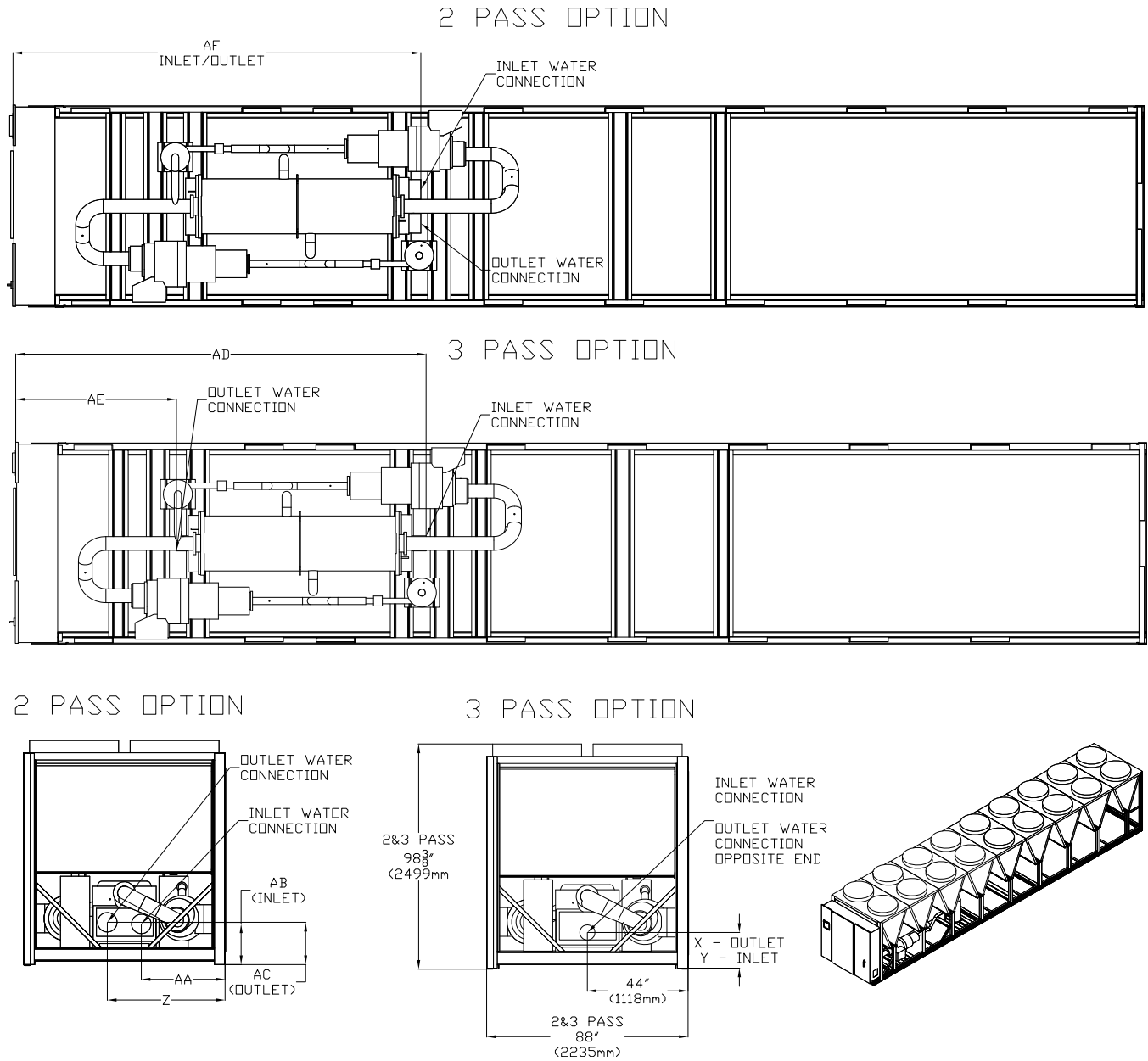
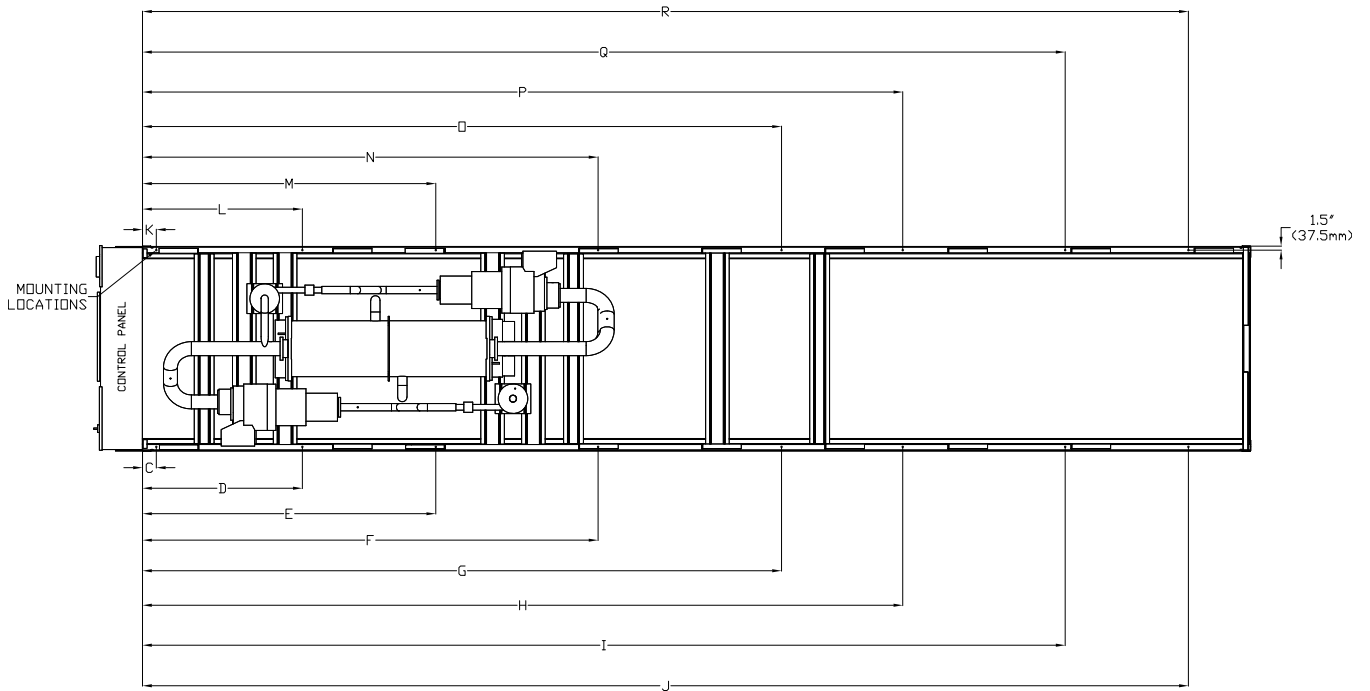

Figure 4. Dimensions — 150 to 330 ton units, standard length, mounting and lifting

MOUNTING LOCATIONS

TOP OF UNIT (CONDENSER REMOVED)
NOT TO SCALE - REPRESENTATION ONLY



LIFTING LOCATIONS

NOT TO SCALE - REPRESENTATION ONLY

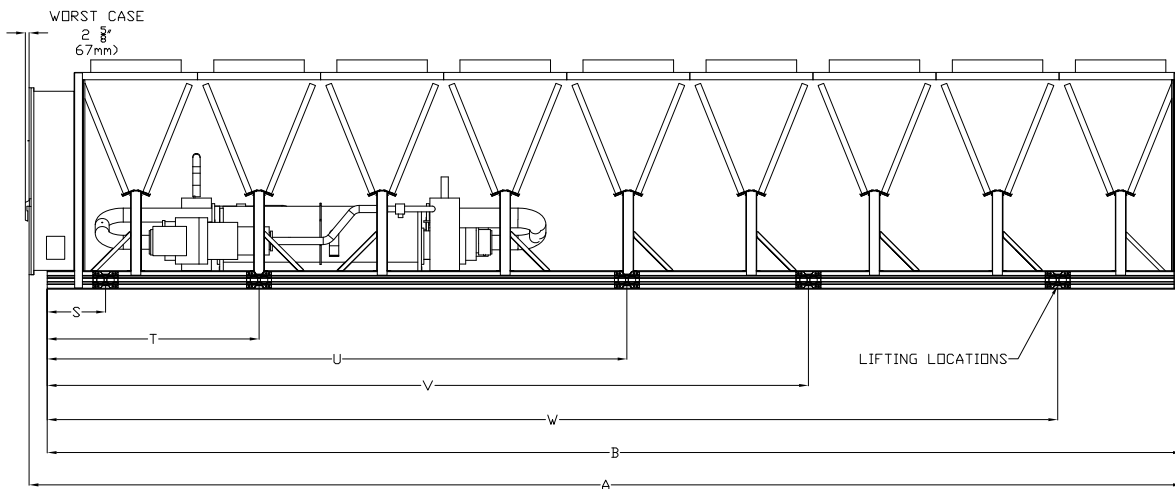



Dimensions and Weights

Table 6. Dimensions — 150 to 330 ton units, standard length, I-P (inch)

Cond Length (a)	4V		5V		6V		7V		8V		9V		8V		9V		8V		9V	
	N/A	N/TDFC A	N/A	TDFC DFC1	N/A	TDFC DFC2	N/A	TDFC DFC1	N/A	TDFC DFC2	N/A	TDFC DFC1	N/A	TDFC DFC2	N/A	TDFC DFC1	N/A	TDFC DFC2	N/A	TDFC DFC1
Pump Opt ^(c)	N/A	N/A	N/A	N/A	N/A	N/A	N/A	N/A	N/A	N/A	N/A	N/A	N/A	N/A	N/A	N/A	N/A	N/A	N/A	N/A
Compr. (e)	GP4V	GP4V	GP4V	GP4V	GP4V	GP4V	GP4V	GP4V	GP4V	GP4V	GP4V	GP4V	GP4V	GP4V	GP4V	GP4V	GP4V	GP4V	GP4V	GP4V
A (e)	233.7	286.4	339.4	392.1	445.0	497.8	550.6	603.4	656.1	708.9	761.7	814.5	867.3	920.1	972.9	1025.7	1078.5	1131.3	1184.1	1236.9
B	223.0	275.8	328.6	381.5	434.3	487.1	539.9	592.7	645.5	698.3	751.1	803.9	856.7	909.5	962.3	1015.1	1067.9	1120.7	1173.5	1226.3
C	11.8	11.8	11.8	11.8	11.8	11.8	11.8	11.8	11.8	11.8	11.8	11.8	11.8	11.8	11.8	11.8	11.8	11.8	11.8	11.8
D	63.0	63.0	63.0	63.0	63.0	63.0	63.0	63.0	63.0	63.0	63.0	63.0	63.0	63.0	63.0	63.0	63.0	63.0	63.0	63.0
E	141.7	137.8	137.8	124.4	137.8	137.8	137.8	137.8	137.8	137.8	137.8	137.8	137.8	137.8	137.8	137.8	137.8	137.8	137.8	137.8
F	204.7	255.9	238.6	196.9	238.6	238.6	238.6	238.6	238.6	238.6	238.6	238.6	238.6	238.6	238.6	238.6	238.6	238.6	238.6	238.6
G	n/a	n/a	315.0	n/a	n/a	n/a	n/a	n/a	n/a	n/a	n/a	n/a	n/a	n/a	n/a	n/a	n/a	n/a	n/a	n/a
H	n/a	n/a	n/a	334.6	413.4	413.4	413.4	413.4	413.4	413.4	413.4	413.4	413.4	413.4	413.4	413.4	413.4	413.4	413.4	413.4
I	n/a	n/a	n/a	n/a	n/a	n/a	n/a	n/a	n/a	n/a	n/a	n/a	n/a	n/a	n/a	n/a	n/a	n/a	n/a	n/a
J	n/a	n/a	n/a	n/a	n/a	n/a	n/a	n/a	n/a	n/a	n/a	n/a	n/a	n/a	n/a	n/a	n/a	n/a	n/a	n/a
K	15.7	15.7	15.7	15.7	15.7	15.7	15.7	15.7	15.7	15.7	15.7	15.7	15.7	15.7	15.7	15.7	15.7	15.7	15.7	15.7
L	82.7	82.7	82.7	82.7	82.7	82.7	82.7	82.7	82.7	82.7	82.7	82.7	82.7	82.7	82.7	82.7	82.7	82.7	82.7	82.7
M	141.7	137.8	137.8	124.4	137.8	137.8	137.8	137.8	137.8	137.8	137.8	137.8	137.8	137.8	137.8	137.8	137.8	137.8	137.8	137.8
N	204.7	255.9	238.6	196.9	238.6	238.6	238.6	238.6	238.6	238.6	238.6	238.6	238.6	238.6	238.6	238.6	238.6	238.6	238.6	238.6
O	n/a	n/a	315.0	n/a	n/a	n/a	n/a	n/a	n/a	n/a	n/a	n/a	n/a	n/a	n/a	n/a	n/a	n/a	n/a	n/a
P	n/a	n/a	n/a	334.6	393.7	393.7	393.7	393.7	393.7	393.7	393.7	393.7	393.7	393.7	393.7	393.7	393.7	393.7	393.7	393.7
Q	n/a	n/a	n/a	n/a	n/a	n/a	n/a	n/a	n/a	n/a	n/a	n/a	n/a	n/a	n/a	n/a	n/a	n/a	n/a	n/a
R	n/a	n/a	n/a	n/a	n/a	n/a	n/a	n/a	n/a	n/a	n/a	n/a	n/a	n/a	n/a	n/a	n/a	n/a	n/a	n/a
S	25.0	25.0	25.0	25.0	25.0	25.0	25.0	25.0	25.0	25.0	25.0	25.0	25.0	25.0	25.0	25.0	25.0	25.0	25.0	25.0
T	153.1	170.6	90.9	90.9	90.9	90.9	90.9	90.9	90.9	90.9	90.9	90.9	90.9	90.9	90.9	90.9	90.9	90.9	90.9	90.9
U	n/a	n/a	211.4	249.4	170.6	170.6	170.6	170.6	170.6	170.6	170.6	170.6	170.6	170.6	170.6	170.6	170.6	170.6	170.6	170.6
V	n/a	n/a	n/a	327.3	355.1	355.1	355.1	355.1	355.1	355.1	355.1	355.1	355.1	355.1	355.1	355.1	355.1	355.1	355.1	355.1
W	n/a	n/a	n/a	n/a	n/a	n/a	n/a	n/a	n/a	n/a	n/a	n/a	n/a	n/a	n/a	n/a	n/a	n/a	n/a	n/a

(a) Condenser length defined by model number digit 25: 4V = A; 5V = B; 6V = C; 7V = D; 8V = E; 9V = F.

(b) Free Cooling defined by model number digit 42: T = TDFC; H = DFC2; J = DFC1.

(c) Pump Package defined by model number digit 40 = 5, 6, 7.

(d) Compressor type defined by model digit 8: 4 = GPMX, 5 = GP4V.

(e) Total unit length includes additional extruded features such as louvers and circuit breaker handles.

Table 7. Dimensions — 150 to 330 ton units, standard length, SI (mm)

Cond Length (a)	4V		5V		6V		5V		6V		7V		8V		7V		8V		9V		8V		9V	
	N/A	N/ TDFC A	TDFC	DFC1	N/A	TDFC	DFC2	DFC1	N/A	TDFC	DFC2	DFC1	NA	TDFC	DFC2	DFC1	NA	TDFC	DFC2	DFC1	NA	TDFC	DFC2	DFC1
Pump Opt(c)	N/A	N/A	N/A	N/A	N/A	N/A	N/A	N/A	N/A	N/A	N/A	N/A	N/A	N/A	N/A	N/A	N/A	N/A	N/A	N/A	N/A	N/A	N/A	N/A
Compr (e)	GP4V	GP4V	GP4V	GP4V	GP4V	GP4V	GP4V	GP4V	GP4V	GP4V	GP4V	GP4V	GP4V	GP4V	GP4V	GP4V	GP4V	GP4V	GP4V	GP4V	GP4V	GP4V	GP4V	GP4V
A (e)	5936	7275	8620	8348	9960	9690	11302	11032	11302	11032	11302	11032	11302	11032	11302	11032	11302	11032	11302	11032	11302	11032	11302	11032
B	5664	7006	8348	8000	9690	9340	11032	10782	11032	10782	11032	10782	11032	10782	11032	10782	11032	10782	11032	10782	11032	10782	11032	10782
C	300	300	300	300	300	300	300	300	300	300	300	300	300	300	300	300	300	300	300	300	300	300	300	300
D	1600	1600	1600	1600	1600	1600	1600	1600	1600	1600	1600	1600	1600	1600	1600	1600	1600	1600	1600	1600	1600	1600	1600	1600
E	3600	3500	3500	3500	3500	3500	3500	3500	3500	3500	3500	3500	3500	3500	3500	3500	3500	3500	3500	3500	3500	3500	3500	3500
F	5200	6500	6060	8000	5000	5000	5000	5000	5000	5000	5000	5000	5000	5000	5000	5000	5000	5000	5000	5000	5000	5000	5000	5000
G	n/a	n/a	8000	8000	n/a	n/a	n/a	n/a	n/a	n/a	n/a	n/a	n/a	n/a	n/a	n/a	n/a	n/a	n/a	n/a	n/a	n/a	n/a	n/a
H	n/a	n/a	n/a	n/a	8500	8500	10500	10500	10500	10500	10500	10500	10500	10500	10500	10500	10500	10500	10500	10500	10500	10500	10500	10500
I	n/a	n/a	n/a	n/a	n/a	n/a	n/a	n/a	n/a	n/a	n/a	n/a	n/a	n/a	n/a	n/a	n/a	n/a	n/a	n/a	n/a	n/a	n/a	n/a
J	n/a	n/a	n/a	n/a	n/a	n/a	n/a	n/a	n/a	n/a	n/a	n/a	n/a	n/a	n/a	n/a	n/a	n/a	n/a	n/a	n/a	n/a	n/a	n/a
K	400	400	400	400	400	400	400	400	400	400	400	400	400	400	400	400	400	400	400	400	400	400	400	400
L	2100	2100	2100	2100	2100	2100	2100	2100	2100	2100	2100	2100	2100	2100	2100	2100	2100	2100	2100	2100	2100	2100	2100	2100
M	3600	3500	3500	3500	3160	3160	3500	3500	3500	3500	3500	3500	3500	3500	3500	3500	3500	3500	3500	3500	3500	3500	3500	3500
N	5200	6500	6060	8000	5000	5000	5000	5000	5000	5000	5000	5000	5000	5000	5000	5000	5000	5000	5000	5000	5000	5000	5000	5000
O	n/a	n/a	8000	8000	n/a	n/a	n/a	n/a	n/a	n/a	n/a	n/a	n/a	n/a	n/a	n/a	n/a	n/a	n/a	n/a	n/a	n/a	n/a	n/a
P	n/a	n/a	n/a	n/a	8500	8500	10000	10000	10000	10000	10000	10000	10000	10000	10000	10000	10000	10000	10000	10000	10000	10000	10000	10000
Q	n/a	n/a	n/a	n/a	n/a	n/a	n/a	n/a	n/a	n/a	n/a	n/a	n/a	n/a	n/a	n/a	n/a	n/a	n/a	n/a	n/a	n/a	n/a	n/a
R	n/a	n/a	n/a	n/a	n/a	n/a	n/a	n/a	n/a	n/a	n/a	n/a	n/a	n/a	n/a	n/a	n/a	n/a	n/a	n/a	n/a	n/a	n/a	n/a
S	635	635	635	635	635	635	635	635	635	635	635	635	635	635	635	635	635	635	635	635	635	635	635	635
T	3890	4334	2309	2309	2309	2309	2309	2309	2309	2309	2309	2309	2309	2309	2309	2309	2309	2309	2309	2309	2309	2309	2309	2309
U	n/a	n/a	5370	5370	6335	6335	4333	4333	4333	4333	4333	4333	4333	4333	4333	4333	4333	4333	4333	4333	4333	4333	4333	4333
V	n/a	n/a	n/a	n/a	8314	8314	9019	9019	9019	9019	9019	9019	9019	9019	9019	9019	9019	9019	9019	9019	9019	9019	9019	9019
W	n/a	n/a	n/a	n/a	n/a	n/a	n/a	n/a	n/a	n/a	n/a	n/a	n/a	n/a	n/a	n/a	n/a	n/a	n/a	n/a	n/a	n/a	n/a	n/a

(a) Condenser length defined by model number digit 25: 4V = A; 5V = B; 6V = C; 7V = D; 8V = E; 9V = F.

(b) Free Cooling defined by model number digit 42: T = TDFC; H = DFC2; J = DFC1.

(c) Pump Package defined by model number digit 40 = 5, 6, 7.

(d) Compressor type defined by model digit 8: 4 = GPMX, 5 = GP4V.

(e) Total unit length includes additional extruded features such as louvers and circuit breaker handles.



Dimensions and Weights

Table 8. Water connection dimensions — 150 to 330 ton units, standard length, without free-cooling or pump package

Unit Size (tons)	150, 165		180, 200		225, 250		275, 300, 330	
	in	mm	in	mm	in	mm	in	mm
X	20.4	520	19.6	498	21.8	554	20.6	523
Y	17.7	450	15.4	391	17.6	447	16.1	408
Z	49.3	1253	49.9	1268	49.9	1268	51.3	1303
AA	38.5	978	37.9	962	37.9	962	36.5	927
AB	19.3	490	17.6	448	19.8	504	18.2	463
AC	19.7	500	18.2	463	20.4	519	18.9	481
AD	176.5	4483	178.2	4526	178.1	4524	178.4	4531
AE	70.3	1786	69.2	1758	69.2	1758	69.3	1760
AF	175.3	4453	176.2	4475	176.2	4475	177.1	4498

Figure 5. Dimensions — 150 to 330 ton units, extended length

VOLTAGE AUTO TRANSFORMER OPTION

USED WITH 200, 230, 380, 400 AND 575V

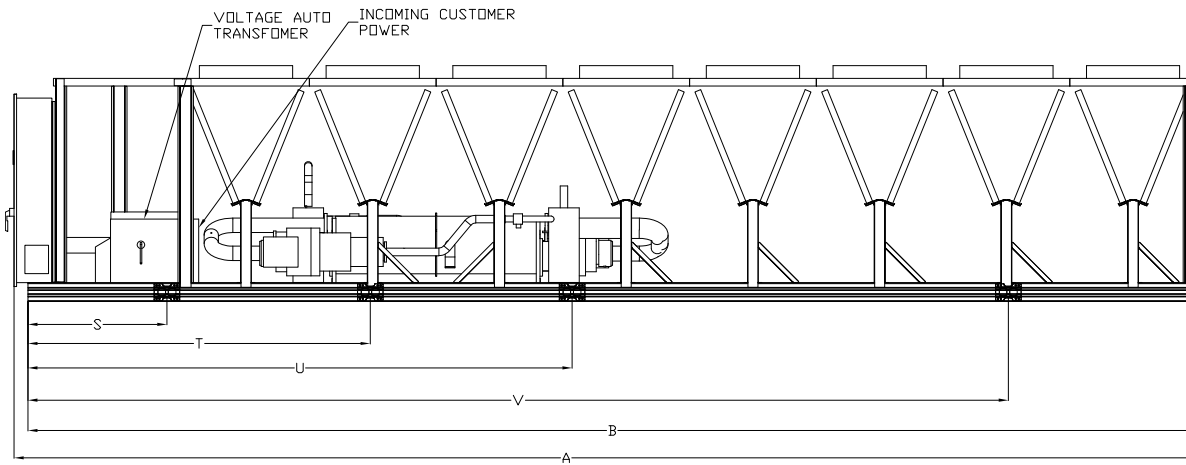

HARMONIC FILTRATION OPTION

LIFTING DIMENSION SAME AS ABOVE

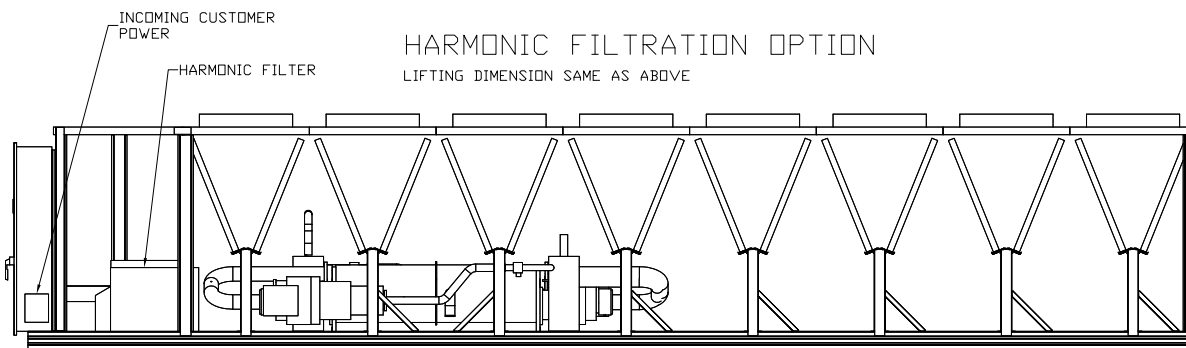

MOUNTING LOCATIONS

TOP VIEW (CONDENSER REMOVED)
NOT TO SCALE - REPRESENTATION ONLY

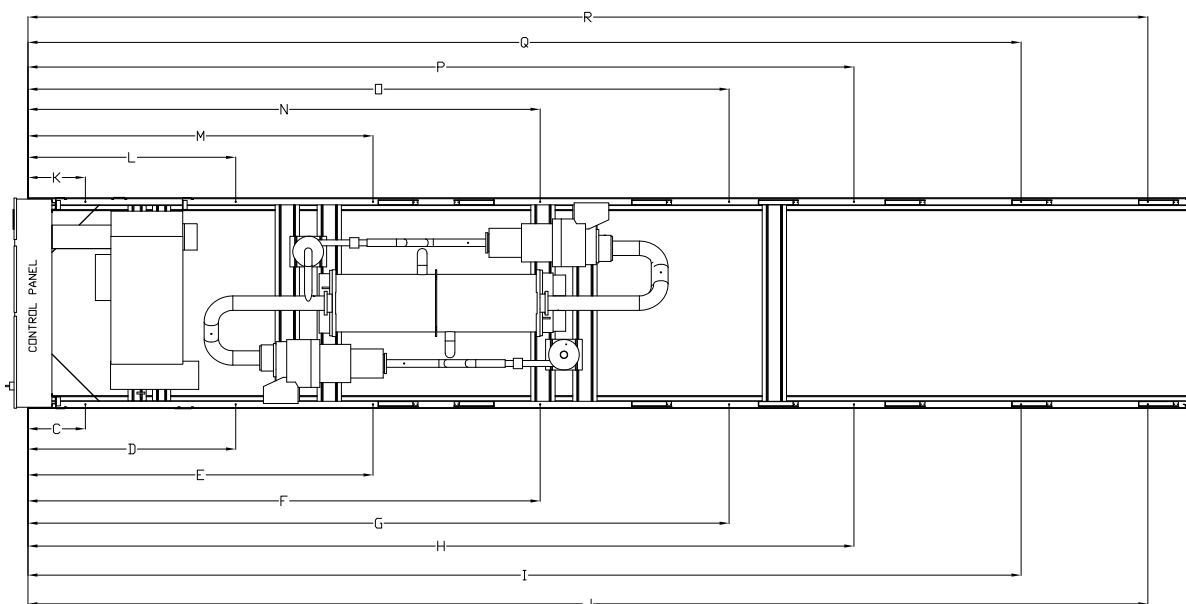



Dimensions and Weights

Table 9. Dimensions — 150 to 330 ton units, extended length, I-P (inch)

Cond Length (a)	4V	5V	5V	6V	6V	7V	7V	8V	8V	9V	9V	7V	8V	8V	9V	9V	8V	8V	9V	9V	
	N/A	N/A	N/TDFC DFC1	N/TDFC DFC2 DFC1	N/TDFC DFC1	N/A	NONE	NONE	TDFC	TDFC	NONE	DFC2 DFC1	TDFC	TDFC	NONE	TDFC	DFC2 DFC1	DFC2 DFC1	TDFC	DFC2 DFC1	
Pump Opt(c)	N/A	N/A	N/A	N/A	N/A	N/A	N/A	NONE	NONE	PUMP	NONE	PUMP	NONE	NONE	PUMP	NONE	NONE	PUMP	NONE	PUMP	
Compr (d)	GP4V	GP4V	GP4V	GP4V	GP4V	GP4V	GP4V	GP4V	GP4V	GP4V	GP4V	GP4V	GP4V	GP4V	GP4V	GP4V	GP4V	GP4V	GP4V	GP4V	
A (e)	286.4	339.4	392.1	445.0	497.8	497.8	497.8	497.8	497.8	497.8	550.6	550.6	550.6	550.6	550.6	550.6	550.6	550.6	550.6	550.6	
B	275.8	328.6	381.5	434.3	487.1	487.1	487.1	487.1	487.1	487.1	540.0	540.0	540.0	540.0	540.0	540.0	540.0	540.0	540.0	540.0	
C	27.6	27.6	51.2	51.2	51.2	51.2	51.2	51.2	51.2	51.2	27.6	27.6	27.6	27.6	27.6	27.6	27.6	27.6	27.6	27.6	
D	114.2	114.2	114.2	114.2	114.2	114.2	114.2	114.2	114.2	114.2	114.2	114.2	114.2	114.2	114.2	114.2	114.2	114.2	114.2	114.2	
E	194.6	190.6	190.6	177.2	190.6	190.6	190.6	190.6	190.6	190.6	249.7	249.7	249.7	249.7	249.7	249.7	249.7	249.7	249.7	249.7	
F	257.6	308.7	249.7	249.7	291.4	291.4	291.4	291.4	291.4	291.4	387.5	387.5	387.5	387.5	387.5	387.5	387.5	387.5	387.5	387.5	
G	n/a	n/a	367.8	n/a	n/a	n/a	n/a	n/a	n/a	n/a	291.4	291.4	291.4	291.4	n/a	n/a	344.3	344.3	344.3	344.3	
H	n/a	n/a	n/a	387.5	466.2	466.2	466.2	466.2	466.2	466.2	466.2	466.2	466.2	466.2	518.0	518.0	420.6	420.6	420.6	420.6	
I	n/a	n/a	n/a	n/a	n/a	n/a	n/a	n/a	n/a	n/a	n/a	n/a	n/a	n/a	n/a	n/a	518.0	518.0	518.0	518.0	
J	n/a	n/a	n/a	n/a	n/a	n/a	n/a	n/a	n/a	n/a	n/a	n/a	n/a	n/a	n/a	n/a	n/a	n/a	n/a	n/a	
K	27.6	27.6	51.2	51.2	51.2	51.2	51.2	51.2	51.2	51.2	27.6	27.6	27.6	27.6	27.6	27.6	27.6	27.6	27.6	27.6	
L	114.2	114.2	114.2	114.2	114.2	114.2	114.2	114.2	114.2	114.2	114.2	114.2	114.2	114.2	114.2	114.2	114.2	114.2	114.2	114.2	
M	194.6	190.6	190.6	177.2	190.6	190.6	190.6	190.6	190.6	190.6	249.7	249.7	249.7	249.7	249.7	249.7	249.7	249.7	249.7	249.7	
N	257.6	308.7	249.7	249.7	291.4	291.4	291.4	291.4	291.4	291.4	387.5	387.5	387.5	387.5	387.5	387.5	387.5	387.5	387.5	387.5	
O	n/a	n/a	367.8	n/a	n/a	n/a	n/a	n/a	n/a	n/a	291.4	291.4	291.4	291.4	n/a	n/a	344.3	344.3	344.3	344.3	
P	n/a	n/a	n/a	387.5	446.5	446.5	446.5	446.5	446.5	446.5	446.5	446.5	446.5	446.5	518.0	518.0	420.6	420.6	420.6	420.6	
Q	n/a	n/a	n/a	n/a	n/a	n/a	n/a	n/a	n/a	n/a	n/a	n/a	n/a	n/a	n/a	n/a	518.0	518.0	518.0	518.0	
R	n/a	n/a	n/a	n/a	n/a	n/a	n/a	n/a	n/a	n/a	n/a	n/a	n/a	n/a	n/a	n/a	n/a	n/a	n/a	n/a	
S	55.1	55.1	58.3	58.3	58.3	58.3	58.3	58.3	58.3	58.3	58.3	58.3	58.3	58.3	58.3	58.3	58.3	58.3	58.3	58.3	
T	206.0	223.5	143.7	143.7	143.7	143.7	143.7	143.7	143.7	143.7	143.7	143.7	143.7	143.7	143.7	143.7	143.7	143.7	143.7	143.7	
U	n/a	n/a	264.3	302.2	223.4	223.4	223.4	223.4	223.4	223.4	302.2	302.2	302.2	302.2	302.2	302.2	302.2	302.2	302.2	302.2	
V	n/a	n/a	n/a	380.2	407.9	407.9	407.9	407.9	407.9	407.9	407.9	407.9	407.9	407.9	407.9	407.9	407.9	407.9	407.9	407.9	407.9
W	n/a	n/a	n/a	n/a	n/a	n/a	n/a	n/a	n/a	n/a	n/a	n/a	n/a	n/a	n/a	n/a	487.2	487.2	487.2	487.2	

(a) Condenser length defined by model number digit 25: 4V = A; 5V = B; 6V = C; 7V = D; 8V = E; 9V = F.
 (b) Free Cooling defined by model number digit 42: T = TDFC; H = DFC2; J = DFC1.
 (c) Pump Package defined by model number digit 40 = 5, 6, 7.
 (d) Compressor type defined by model digit 8: 4 = GPMX; 5 = GP4V.
 (e) Total unit length includes additional extruded features such as lowers and circuit breaker handles.

Table 10. Dimensions — 150 to 330 ton units, extended length, SI (mm)

Cond Length (a)	4V	5V	6V	5V	6V	7V	8V	7V	8V	9V	7V	8V	9V	7V	8V	9V	8V	9V	8V	9V
	N/A	N/ TDFC DFC1 A	N/ TDFC DFC2 DFC1 A	N/A	N/A	N/A	NONE	NONE	TDFC	TDFC DFC1	TDFC DFC2 DFC1	NONE	NONE	TDFC	TDFC DFC1	TDFC DFC2 DFC1	NONE	TDFC	TDFC DFC1	TDFC DFC2 DFC1
Pump Opt(c)	N/A	N/A	N/A	N/A	N/A	N/A	NONE	NONE	NONE	PUMP	PUMP	NONE	NONE	PUMP	PUMP	NONE	NONE	PUMP	PUMP	PUMP
Compr (c)	GP4V	GP4V	GP4V	GP4V	GP4V	GP4V	GP4V	GP4V	GP4V	GP4V	GP4V	GP4V	GP4V	GP4V	GP4V	GP4V	GP4V	GP4V	GP4V	GP4V
A (e)	7275	8620	9960	11302	12646	12646	12646	12646	12646	13984	13984	13984	13984	13984	13984	13984	13984	13984	13984	13984
B	7006	8348	9690	11032	12374	12374	12374	12374	12374	13715	13715	13715	13715	13715	13715	13715	13715	13715	13715	13715
C	700	700	1300	1300	1300	1300	1300	1300	1300	700	700	700	700	700	700	700	700	700	700	700
D	2900	2900	2900	2900	2900	2900	2900	2900	2900	2900	2900	2900	2900	2900	2900	2900	2900	2900	2900	2900
E	4942	4842	4842	4502	4842	4842	4842	4842	4842	4502	4502	4502	4502	4502	4502	4502	4502	4502	4502	4502
F	6542	7842	6342	6342	7402	7402	7402	7402	7402	6342	6342	6342	6342	6342	6342	6342	6342	6342	6342	6342
G	n/a	n/a	9342	n/a	n/a	n/a	n/a	n/a	n/a	7402	7402	7402	n/a	n/a	8744	8744	7402	7402	7402	7402
H	n/a	n/a	n/a	9842	11842	11842	11842	11842	11842	11842	11842	11842	13158	13158	10684	10684	9250	9250	9250	9250
I	n/a	n/a	n/a	n/a	n/a	n/a	n/a	n/a	n/a	n/a	n/a	n/a	n/a	n/a	13158	13158	12750	12750	11842	11842
J	n/a	n/a	n/a	n/a	n/a	n/a	n/a	n/a	n/a	n/a	n/a	n/a	n/a	n/a	n/a	n/a	14500	14500	14500	14500
K	700	700	1300	1300	1300	1300	1300	1300	1300	700	700	700	700	700	700	700	1300	1300	1300	1300
L	2900	2900	2900	2900	2900	2900	2900	2900	2900	2900	2900	2900	2900	2900	2900	2900	2900	2900	2900	2900
M	4942	4842	4842	4502	4842	4842	4842	4842	4842	4502	4502	4502	4502	4502	4502	4502	4842	4842	4842	4842
N	6542	7842	6342	6342	7402	7402	7402	7402	7402	6342	6342	6342	6342	6342	6342	6342	6342	6342	6342	6342
O	n/a	n/a	9342	n/a	n/a	n/a	n/a	n/a	n/a	7402	7402	7402	n/a	n/a	8744	8744	7402	7402	7402	7402
P	n/a	n/a	n/a	9842	11342	11342	11342	11342	11342	11342	11342	11342	13158	13158	10684	10684	9250	9250	9250	9250
Q	n/a	n/a	n/a	n/a	n/a	n/a	n/a	n/a	n/a	n/a	n/a	n/a	n/a	n/a	n/a	n/a	12750	12750	11342	11342
R	n/a	n/a	n/a	n/a	n/a	n/a	n/a	n/a	n/a	n/a	n/a	n/a	n/a	n/a	n/a	n/a	14500	14500	14500	14500
S	1400	1400	1482	1482	1482	1482	1482	1482	1482	1482	1482	1482	1482	1482	1482	1482	1482	1482	1482	1482
T	5232	5676	3651	3651	3651	3651	3651	3651	3651	3651	3651	3651	3651	3651	3651	3651	3651	3651	3651	3651
U	n/a	n/a	6712	7677	5675	5675	5675	5675	5675	7677	7677	7677	7677	7677	7677	7677	5675	5675	5675	5675
V	n/a	n/a	n/a	9657	10361	10361	10361	10361	10361	10361	10361	10361	9657	9657	9657	9657	10361	10361	10361	10361
W	n/a	n/a	n/a	n/a	n/a	n/a	n/a	n/a	n/a	n/a	n/a	n/a	n/a	n/a	n/a	n/a	13716	13716	13716	13716

(a) Condenser length defined by model number digit 25: 4V = A; 5V = B; 6V = C; 7V = D; 8V = E; 9V = F.

(b) Free Cooling defined by model number digit 42: T = TDFC; H = DFC2; J = DFC1.

(c) Pump Package defined by model number digit 40 = 5, 6, 7.

(d) Compressor type defined by model digit 8: 4 = GPMX; 5 = GP4V.

(e) Total unit length includes additional extruded features such as louvers and circuit breaker handles.



Dimensions and Weights

Table 11. Water connection dimensions — 150 to 330 ton units, extended length, without free-cooling or pump package

Unit Size (tons)	150, 165		180, 200		225, 250		275, 300, 330	
	in	mm	in	mm	in	mm	in	mm
X	20.4	520	19.6	498	21.8	554	20.6	523
Y	17.7	450	15.4	391	17.6	447	16.1	408
Z	49.3	1253	49.9	1268	49.9	1268	51.3	1303
AA	38.5	978	37.9	962	37.9	962	36.5	927
AB	19.3	490	17.6	448	19.8	504	18.2	463
AC	19.7	500	18.2	463	20.4	519	18.9	481
AD	229.3	5824	231.0	5867	231.0	5867	231.2	5872
AE	123.1	3127	122.1	3101	122.1	3101	122.1	3101
AF	227.9	5794	229.1	5819	229.1	5819	229.9	5839

Figure 6. Water connection dimensions — 150 to 330 ton units with free-cooling or pump package option

DIRECT FREE COOLING OPTION

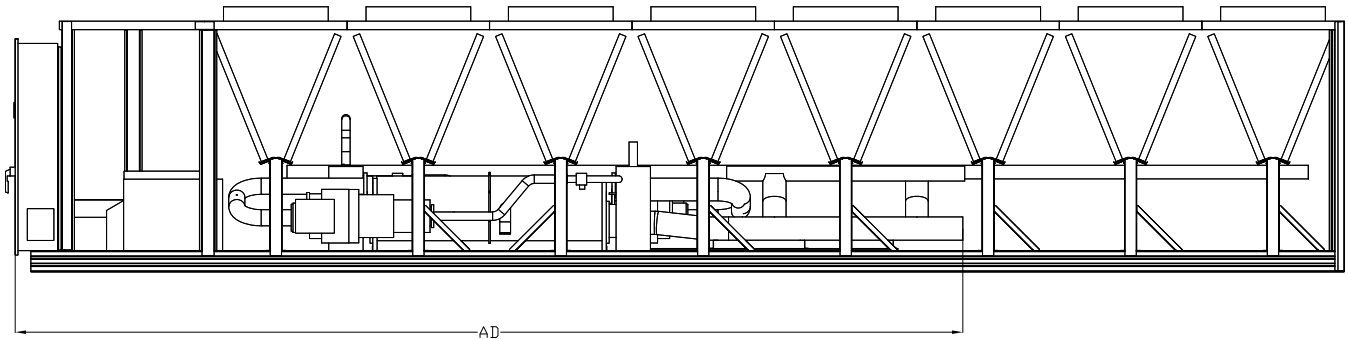

FREE COOLING OPTIONS

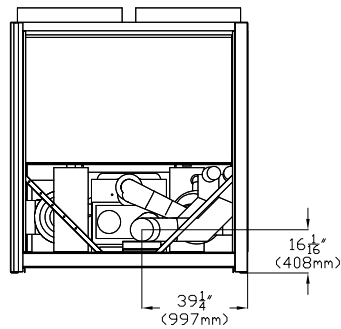

PUMP PACKAGE OPTIONS

INLET AND OUTLET/2 PASS AND 3 PASS

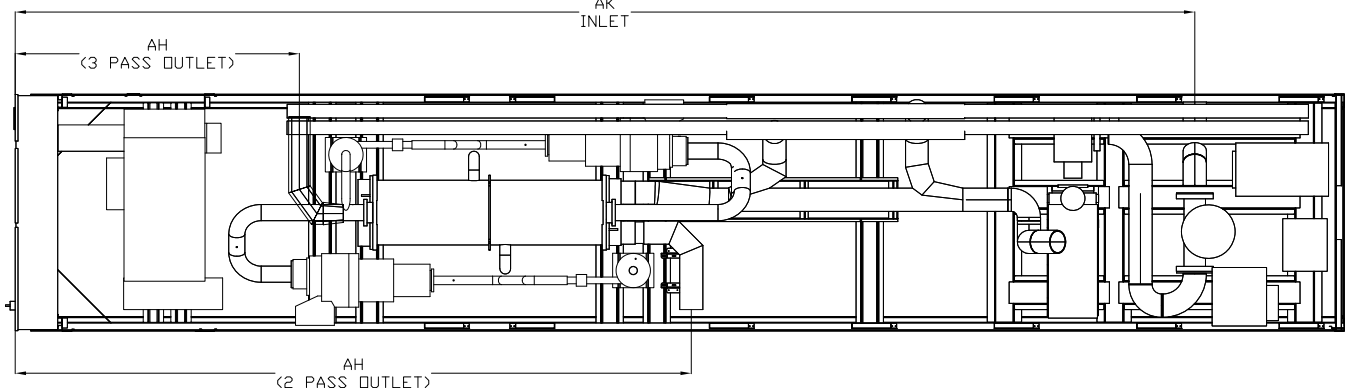
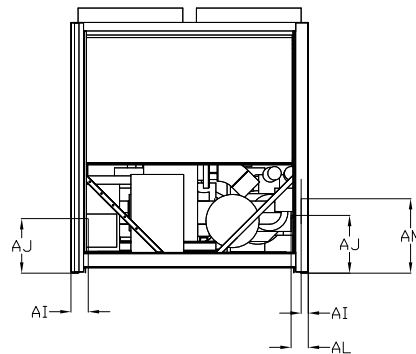



Dimensions and Weights

Table 12. Water connection dimensions — 150 to 330 ton units, with free-cooling (no pump package)

Unit Size (tons)	165		180, 200		225, 250		275		300, 330	
	in	mm	in	mm	in	mm	in	mm	in	mm
Standard Length										
X	20.4	520	19.6	498	21.8	554	20.6	523	20.6	523
Z	49.3	1253	49.9	1268	49.9	1268	51.3	1303	51.3	1303
AC	19.7	500	18.2	463	20.4	519	18.9	480	18.9	480
AD ^(a)	270.9	6882	270.9	6881	270.9	6881	298.8	7588	298.8	7588
AE	70.3	1786	69.2	1758	69.2	1758	69.3	1760	69.3	1760
AF	176.2	4475	176.2	4475	176.2	4475	177.1	4498	177.1	4498
AG	270.9	6881	270.9	6881	270.9	6881	298.8	7588	298.8	7588
Extended Length^(b)										
X	20.4	520	19.6	498	21.8	554	20.6	523	20.6	523
Z	49.3	1253	49.9	1268	49.9	1268	51.3	1303	51.3	1303
AC	19.7	500	18.2	463	20.4	519	18.9	480	18.9	480
AD ^(a)	323.7	8222	323.7	8222	323.7	8222	351.6	8930	351.6	8930
AE	123.1	3127	122.0	3100	122.0	3100	122.0	3100	122.0	3100
AF	228.0	5791	229.1	5819	229.1	5819	229.1	5819	229.1	5819
AG	323.7	8222	323.7	8222	326.5	8293	351.6	8930	351.6	8930

Note: Free-cooling defined by model number digit 42: T = TDFC; J = DFC1; H = DFC2.

^(a) Only applicable on units with direct free-cooling cooling option (model number digit 42 = T, J, or H).

^(b) Extended Length is required for voltages 200V, 230V, 380V, 400V, 575V (model number digit 9 = A, B, C, D, F), and harmonic filtration model number digit 44 = L.

Table 13. Water connection inlet dimensions — 275, 300, 330 ton units with pump package option

Unit Option	Standard Length		Extended Length ^(a)	
	in	mm	in	mm
AK	383.5	9741	436.3	11081
AL	2.9	73	2.9	73
AM	27.2	691	27.2	691

Note: Free-cooling defined by model number digit 42: T = TDFC; J = DFC1; H = DFC2.

^(a) Extended Length is required for voltages 200V, 230V, 380V, 400V, 575V (model number digit 9 = A, B, C, D, F), and harmonic filtration model number digit 44 = L.

Table 14. Water connection outlet dimensions — 275, 300, 330 ton units with pump package option

Unit Option	50HP 2-Pass		60HP or 75HP 2-Pass		50HP 3-Pass		60HP or 75HP 3-Pass	
	in	mm	in	mm	in	mm	in	mm
Standard Length								
AH	191.6	4866	193.4	4913	54.5	1385	52.3	1327
AI	4.5	115	0.6	16	7	177	8	204
AJ	18.9	481	18.9	481	20.6	523	19.6	497
Extended Length^(a)								
AH	244.4	6208	246.3	6255	107.3	2727	105.1	2669
AI	4.5	115	0.6	16	7	177	8	20
AJ	18.9	481	18.9	481	20.6	523	19.6	497

Note: Pump Package defined by model number digit 40 = 5 (50 HP), 6 (60 HP), 7 (75 HP). Pass options are defined by model number digits 19 and 20 (C2 or D2 are 2-pass, C3 is 3-pass).

^(a) Extended Length is required for voltages 200V, 230V, 380V, 400V, 575V (model number digit 9 = A, B, C, D, F), and harmonic filtration model number digit 44 = L.

Unit Sizes 375 to 550 Tons

Figure 7. Dimensions – 375 to 550 ton units without direct-free cooling

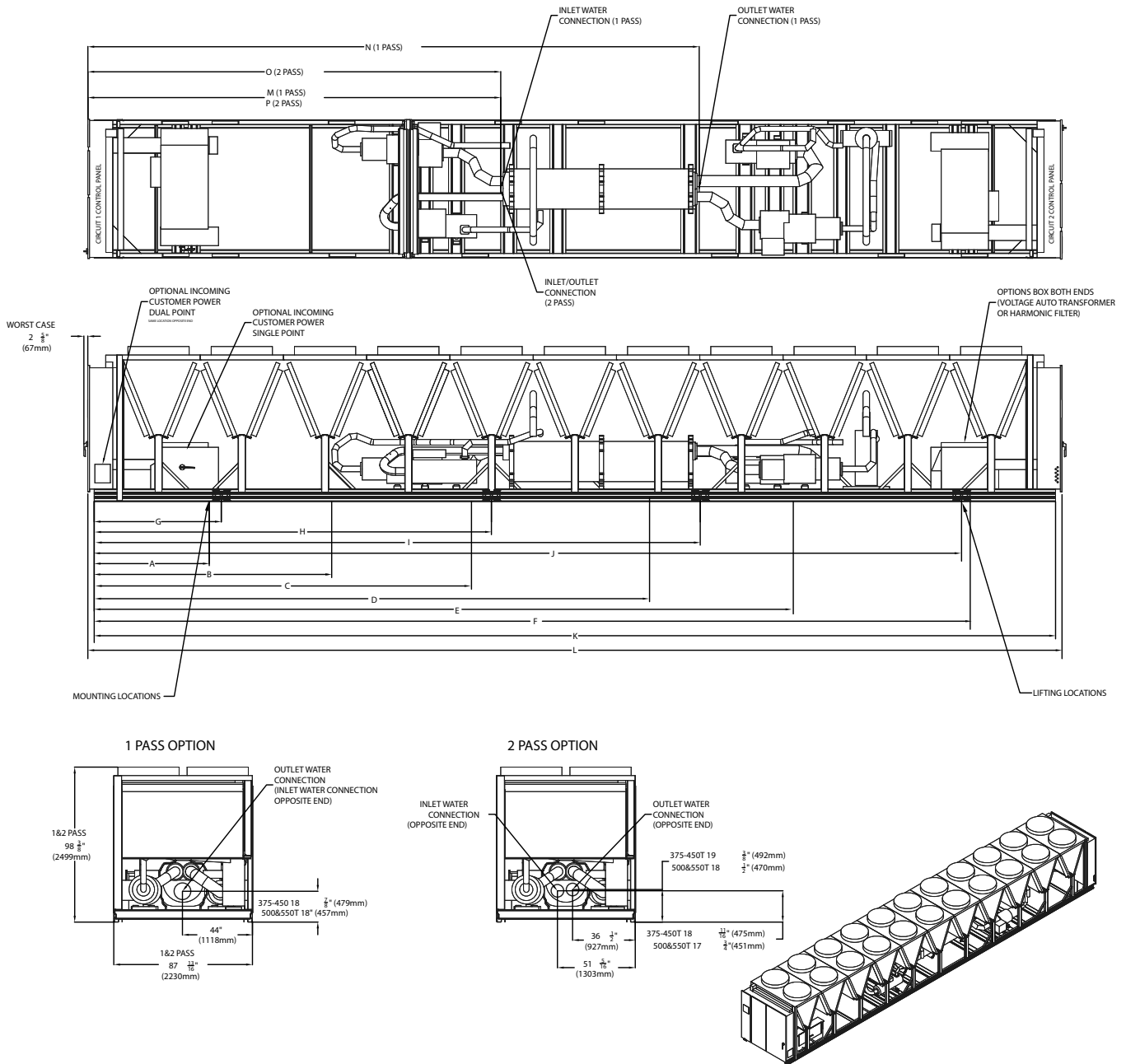

Table 15. Dimensions — 375 to 550 ton units

Unit Size (tons)	375, 440		375, 440		380, 450		500, 550	
Unit Length	Standard		Extended ^(a)		Standard		Standard	
Dimension	in	mm	in	mm	in	mm	in	mm
A	52.4	1330	52.4	1330	76.0	1930	76.0	1930
B	99.6	2530	99.6	2530	146.9	3730	146.9	3730
C	180.6	4588	180.6	4588	233.5	5930	233.5	5930



Dimensions and Weights

Table 15. Dimensions — 375 to 550 ton units (continued)

Unit Size (tons)	375, 440		375, 440		380, 450		500, 550	
	Standard		Extended ^(a)		Standard		Standard	
Dimension	in	mm	in	mm	in	mm	in	mm
D	298.7	7588	298.7	7588	351.6	8930	351.6	8930
E	377.5	9588	377.5	9588	430.3	10930	430.3	10930
F	474.4	12050	495.6	12588	548.4	13930	548.4	13930
G	77.2	1962	77.2	1962	77.2	1962	77.2	1962
H	196.5	4990	196.5	4990	249.3	6332	249.3	6332
I	332.9	8455	332.9	8455	385.7	9797	385.7	9797
J	460.6	11700	490.4	12455	543.2	13797	543.2	13797
K	498.9	12671	551.7	14012	604.5	15355	604.5	15355
L ^(b)	517.5	13146	570.4	14487	623.2	15829	623.2	15829
M	200.7	5098	200.7	5098	253.5	6440	253.5	6440
N	333.9	8480	333.9	8480	386.7	9822	389.8	9902
O	200.7	5098	200.7	5098	253.5	6440	253.5	6440
P	200.7	5098	200.7	5098	253.5	6440	253.5	6440

^(a) Extended Length Units are defined model number digit 44 = L and model number digit 9: 380 = C, 400=D, 575 = F or model number digit 9: 380 = C, 400 = D ,575 = F.

^(b) Total unit length includes additional extruded features such as circuit breaker handles.

Figure 8. Dimensions — 375 to 550 ton units with direct-free cooling

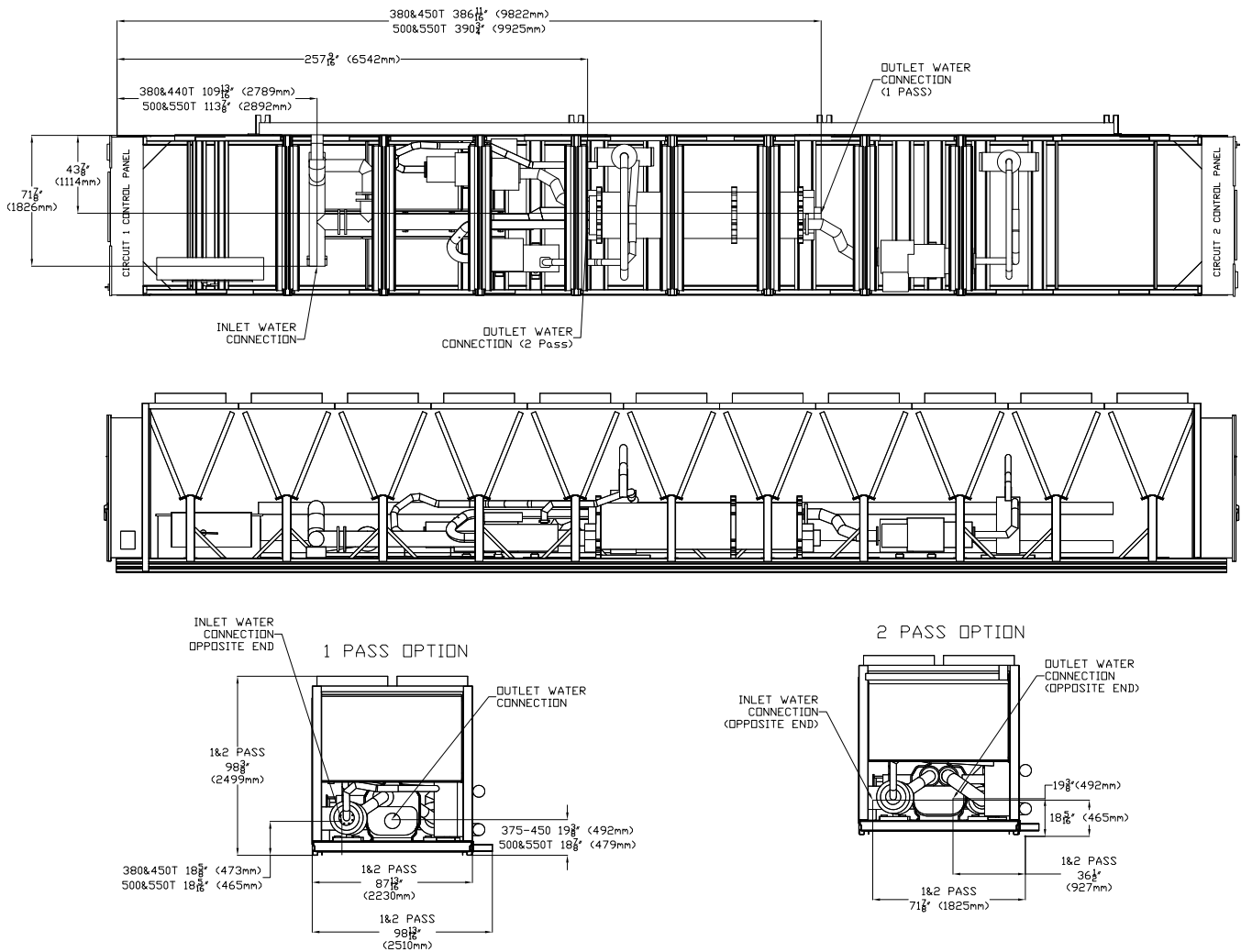

Installation Mechanical

Location Requirements

Sound Considerations

- Locate the unit away from sound-sensitive areas.
- Install the optional elastomeric isolators under the unit. See Isolation and Sound Emission section.
- Chilled water piping should not be supported by chiller frame.
- Install rubber vibration isolators in all water piping.
- Use flexible electrical conduit.
- Seal all wall penetrations.

Note: Consult an acoustical engineer for critical applications.

Foundation

Provide rigid, non-warping mounting pads or a concrete foundation of sufficient strength and mass to support the applicable operating weight (completed piping and full operating charges of refrigerant, oil and water). Attached piping must be fully supported by an independent structure/system, without being connected to the waterbox. Once in place, the unit must be level within 1/2-inch (12.7 mm) across its length and width. Trane is not responsible for equipment problems resulting from an improperly designed or constructed foundation.

Clearances

Provide enough space around the unit to allow the installation and maintenance personnel unrestricted access to all service points. See submittal drawings for the unit dimensions to provide sufficient clearance for the opening of control panel doors and unit service. See Dimensions and Weights chapter for minimum clearances. In all cases, local codes which require additional clearances will take precedence over these recommendations.

For close spacing information, see *Close-Spacing and Restricted Airflow Situations, Ascend™ Chiller Models ACR and ACS, Sintesis™ Chiller Model RTAF Engineering Bulletin (AC-PRB001*-EN)*.

Lifting and Moving Instructions

⚠ WARNING

Heavy Object!

Failure to follow instructions below could result in unit dropping which could result in death or serious injury, and equipment or property-only damage. Ensure that all the lifting equipment used is properly rated for the weight of the unit being lifted. Each of the cables (chains or slings), hooks, and shackles used to lift the unit must be capable of supporting the entire weight of the unit. Lifting cables (chains or slings) may not be of the same length. Adjust as necessary for even unit lift.

⚠ WARNING

Improper Unit Lift!

Failure to properly lift unit in a LEVEL position could result in unit dropping and possibly crushing operator/technician which could result in death or serious injury, and equipment or property-only damage. Test lift unit approximately 24 inches (61 cm) to verify proper center of gravity lift point. To avoid dropping of unit, reposition lifting point if unit is not level.

⚠ WARNING

Proper Lifting Configuration Required!

Failure to follow instructions below could cause the unit to drop which could result in death, serious injury or equipment damage. Use ONLY lifting locations designated with label shown below. DO NOT use locations marked with do-not-lift label. See following figures for acceptable lifting configuration, and refer to labels on the unit.

Figure 9. Lift/Do Not Lift labels

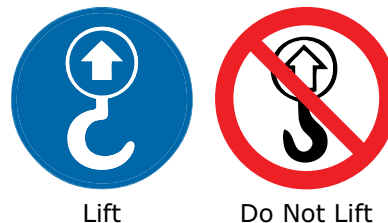

NOTICE

Equipment Damage!

Moving the chiller using a fork lift could result in equipment or property-only damage. Do not use a fork lift to move the chiller!

Important:

- See unit nameplate and/or unit submittal for total shipping weight.
- See following figures for unit lifting configuration.
- See Dimensions and Weights chapter, or unit submittal, for lifting point locations.
- Diagram is generic representation of unit.
- The maximum rigging angle at each chiller lift point is 30° from vertical.
- Do not allow lifting straps to contact unit during lifting.

To determine the lift configuration, see the following table and corresponding figures.

Table 16. Lift configuration selections

Condenser Length	Lift Configuration (Points)			
	4 Figure 10, p. 37	6 Figure 11, p. 37	8 Figure 12, p. 38	10 Figure 13, p. 38
	Used with model number selections:			
4V	Digit 42 = X	—	—	—
5V	Digit 42 = X or T	Digit 42 = J	Digit 42 = H	—
6V	—	Digit 42 = X or T	Digit 42 = J or H	—
7V	—	—	Digit 40 = X and Digit 42 = X, T or J Digit 40 = 5, 6, or 7 and Digit 42 = J	Digit 42 = H
8V	—	—	Digit 40 = X and Digit 42 = X or T Digit 40 = 5, 6, or 7 and Digit 42 = T	Digit 42 = J or H
9V	—	—	—	All
11V	—	—	All	—

Note: Condenser length is designated by model number digit 25. Model number digit 40 designates pump option, and digit 42 is free-cooling.

Figure 10. 4-point lift configuration

Spreader bar/lifting rig width: 96 inch

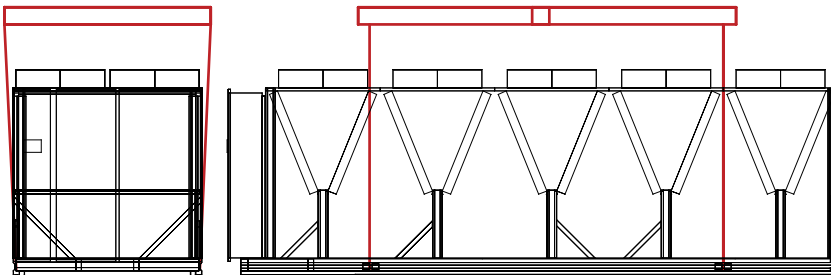
Figure 11. 6-point lift configuration

Spreader bar/lifting rig width: 96 inch

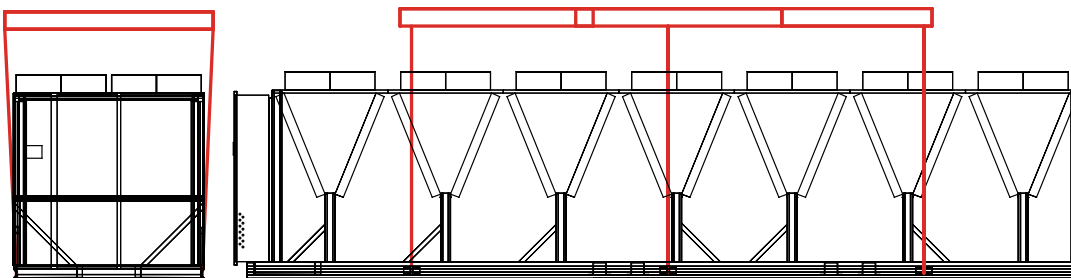
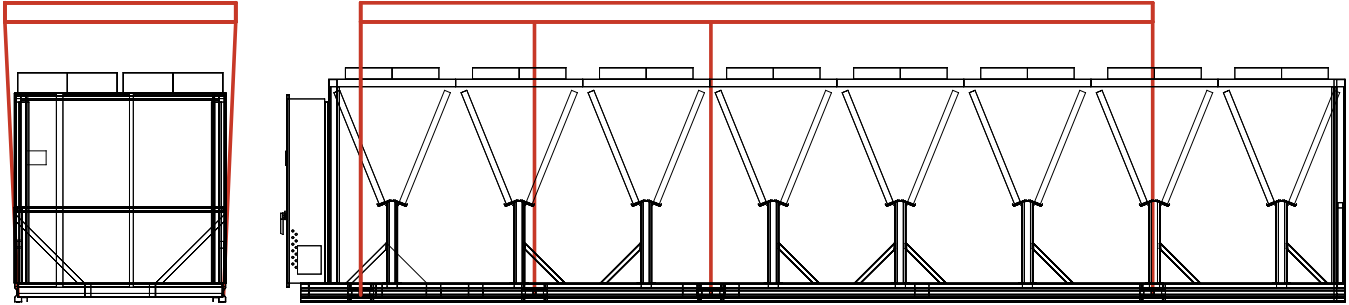
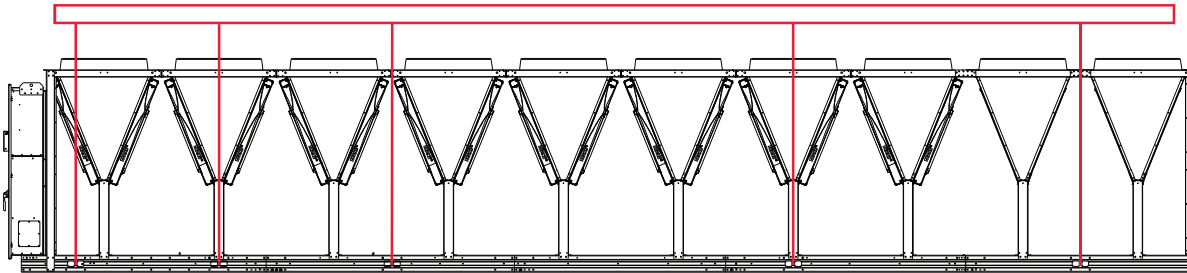

Figure 12. 8–point lift configuration

Spreader bar/lifting rig width:
 120 inch (11V units with direct free-cooling option)
 96 inch (all other units)

Figure 13. 10–point lift configuration

Spreader bar/lifting rig width:96 inch



Isolation and Sound Emission

The most effective form of isolation is to locate the unit away from any sound sensitive area. Structurally transmitted sound can be reduced by elastomeric vibration eliminators. Spring isolators are not recommended. Consult an acoustical engineer in critical sound applications.

For maximum isolation effect, isolate water lines and electrical conduit. Wall sleeves and rubber isolated piping hangers can be used to reduce the sound transmitted through water piping. To reduce the sound transmitted through electrical conduit, use flexible electrical conduit.

State and local codes on sound emissions should always be considered. Since the environment in which a sound source is located affects sound pressure, unit placement must be carefully evaluated. Sound power levels are available on request.

Unit Isolation and Leveling

For additional reduction of sound and vibration, install the optional elastomeric isolators.

Construct an isolated concrete pad for the unit or provide concrete footings at the unit mounting points. Mount the unit directly to the concrete pads or footings.

Level the unit using the base rail as a reference. The unit must be level within 1/2 inch (12.7 mm) over the entire length and width. Use shims as necessary to level the unit.

Elastomeric Isolators

Note: See the unit submittal, or tables in this section, for point weights, isolator locations, and isolator selections.

1. Secure the isolators to the mounting surface using the mounting slots in the isolator base plate. Do not fully tighten the isolator mounting bolts at this time.
2. Align the mounting holes in the base of the unit with the threaded positioning pins on the top of the isolators.
3. Lower the unit onto the isolators and secure the isolator to the unit with a nut.
4. Level the unit carefully. Fully tighten the isolator mounting bolts.

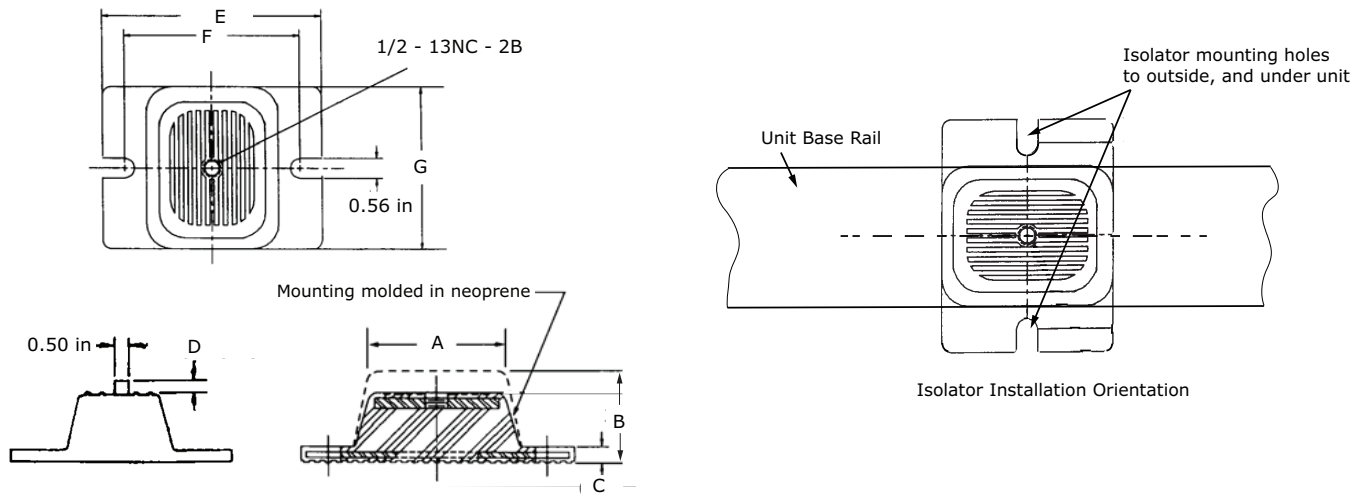
Figure 14. Elastomeric isolator

Table 17. Elastomeric isolator specifications

Isolator	Max Load (lb)	Dimension (in)								Type
		Max Deflection	A	B	C	D	E	F	G	
Charcoal 60	1100	0.5	2.5	2.88	0.25	1.13	5.50	4.12	3.38	RDP3-WR
Brown 61	1500	0.5	3.0	2.75	0.38	1.60	6.25	5.00	4.63	RDP4-WR
Brick Red 62	2250	0.5	3.0	2.75	0.38	1.60	6.25	5.00	4.63	RDP4-WR
Lime 63	3000	0.5	3.0	2.75	0.38	1.60	6.25	5.00	4.63	RDP4-WR
Charcoal 64	4000	0.5	3.0	2.75	0.38	1.60	6.25	5.00	4.63	RDP4-WR

Note: Maximum deflection is 0.5 for all isolators.

Seismic/Wind Load Isolators

Table 18. Seismic/wind load isolators

Isolator	Max Load (lb)	Dimensions (in)				Type
		Max Deflection	Length	Width	Height	
B-64	4480	0.06	8.0	8.0	0.75	Neoprene pad

Figure 15. Isolation pad – installed

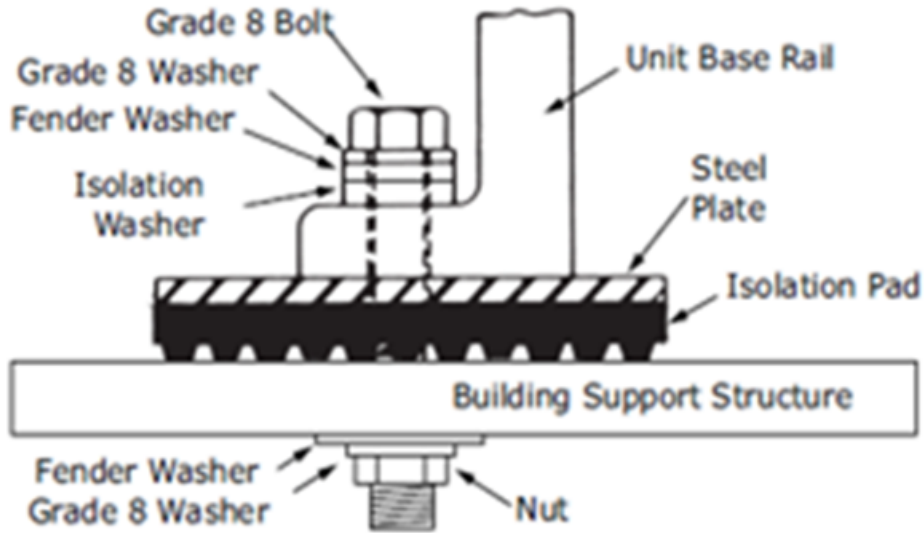

Mounting Locations, Weights, Isolators

See figure below for mounting point location designations.

Figure 16. Mounting point locations (top view)

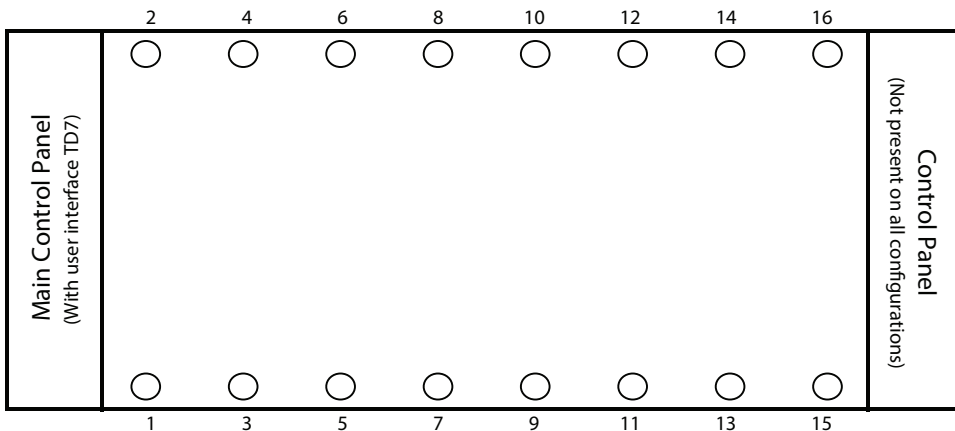

Note: Quantity of isolators varies with unit. See submittal for actual number required for specific unit.

Point Weights

Table 19. Point weights - I-P (lb)

Cond ^(a)	Free-Cooling ^(b)	Pump ^(c)	Unit Size	Mounting Location															
				Standard Length Units								Misting Location							
				1	2	3	4	5	6	7	8	9	10	11	12	13	14	15	16
4V	—	—	150	1820	1610	1870	1680	1720	1790	740	940	—	—	—	—	—	—		
4V	—	—	165	1830	1630	1880	1700	1740	1810	750	950	—	—	—	—	—	—		
4V	—	—	180	1830	1630	1890	1710	1750	1830	750	960	—	—	—	—	—	—		
5V	NONE	—	165	1760	1710	1910	1860	1950	1970	950	1100	—	—	—	—	—	—		
5V	NONE	—	180	1780	1760	1940	1930	1980	2050	960	1130	—	—	—	—	—	—		
5V	NONE	—	200	1780	1770	1950	1930	1990	2060	960	1130	—	—	—	—	—	—		
5V	NONE	—	225	1960	1880	2170	2150	2210	2330	1020	1270	—	—	—	—	—	—		
5V	NONE	—	250	1970	1890	2180	2160	2220	2340	1020	1270	—	—	—	—	—	—		
5V	TDFC	—	165	1710	1440	2560	2170	2960	2530	1970	1860	—	—	—	—	—	—		
5V	TDFC	—	180	2110	2250	2430	2600	2570	2780	1460	1800	—	—	—	—	—	—		
5V	DFC1	—	165	1910	1990	2360	2520	2480	2800	1750	2400	350	590	—	—	—	—		
5V	DFC1	—	180	1830	2030	2500	2600	3010	2880	1060	2430	710	590	—	—	—	—		
5V	DFC2	—	165	1720	1710	1970	2090	2180	2420	2340	2930	1030	1560	—	—	—	—		
5V	DFC2	—	180	1780	1790	2090	2210	2340	2570	2510	3090	1070	1600	—	—	—	—		
6V	NONE	—	200	1800	1850	1990	1910	1970	1950	1290	1400	280	300	—	—	—	—		
6V	NONE	—	225	2000	1930	2240	2140	2120	2130	1370	1550	280	330	—	—	—	—		
6V	NONE	—	250	2050	1980	2300	2200	2180	2190	1390	1560	280	330	—	—	—	—		
6V	NONE	—	275	2070	2030	2330	2230	2200	2220	1430	1580	280	330	—	—	—	—		
6V	TDFC	—	200	1720	2000	2600	2660	3020	2880	1160	2070	930	960	—	—	—	—		
6V	TDFC	—	225	1950	2000	2900	2920	2890	3080	1740	2170	680	970	—	—	—	—		
6V	TDFC	—	250	2170	2240	2520	2630	3510	3740	1190	1240	940	1520	—	—	—	—		
6V	TDFC	—	275	1840	1950	2930	3010	3280	3330	1190	2390	930	940	—	—	—	—		
6V	DFC1	—	200	1680	1630	2370	2430	2460	2750	2550	3340	1340	1890	—	—	—	—		
6V	DFC1	—	225	1700	1650	2420	2470	2520	2800	2600	3380	1340	1890	—	—	—	—		
6V	DFC1	—	250	1710	1660	2440	2480	2540	2820	2630	3390	1340	1890	—	—	—	—		
6V	DFC2	—	200	1680	1710	2420	2370	2560	2570	1990	2740	1790	2340	660	760	—	—		
6V	DFC2	—	225	1690	1730	2460	2410	2610	2610	2020	2770	1800	2350	650	760	—	—		
6V	DFC2	—	250	1700	1740	2480	2430	2640	2630	2040	2780	1800	2350	650	760	—	—		
7V	NONE	—	275	1950	1850	2120	1990	2040	2010	1840	2030	870	960	—	—	—	—		
7V	NONE	—	300	1950	1850	2130	2000	2050	2020	1840	2030	880	960	—	—	—	—		

Table 19. Point weights - I-P (lb) (continued)

Cond(a)	Free-Cooling(b)	Pump(c)	Unit Size	Mounting Location															
				1	2	3	4	5	6	7	8	9	10	11	12	13	14	15	16
7V	TDFC	—	275	1900	1970	2630	2680	2470	2720	2310	2940	1710	2500	—	—	—	—	—	—
7V	DFC1	—	275	1940	1760	2240	2420	2380	2640	2390	2870	1680	1950	1150	1510	—	—	—	—
7V	DFC1	PUMP	275	2010	2000	2060	1980	2510	2600	1290	1880	1690	1840	2550	2700	2480	3160	—	—
7V	DFC2	—	275	1580	1640	2490	2510	2890	2850	2530	3470	2180	2890	560	650	—	—	—	—
7V	DFC2	PUMP	275	1560	1630	2760	2720	2700	2760	1950	2880	2350	2720	2430	2820	1250	1500	—	—
7V	TDFC	—	300	1790	1740	2480	2530	2550	2830	2650	3420	1690	2250	—	—	—	—	—	—
8V	NONE	—	300	1990	1940	2340	2240	2350	2310	1950	2060	750	870	—	—	—	—	—	—
8V	NONE	None	300	1990	1940	2340	2240	2350	2310	1950	2060	750	870	—	—	—	—	—	—
8V	TDFC	None	300	1750	1790	2420	2440	2410	2640	2440	2910	1770	1930	1270	1730	—	—	—	—
8V	TDFC	PUMP	300	1930	1980	1990	1990	2480	2620	1300	1910	1730	1900	2640	2830	2600	3400	—	—
8V	DFC1	None	300	1720	1700	2510	2570	2650	2890	2740	3440	2250	2900	720	890	—	—	—	—
8V	DFC1	PUMP	300	1760	1800	2320	2260	2910	2990	2020	2980	2400	2770	2490	2870	1480	1740	—	—
8V	DFC2	NONE	300	1930	1750	2030	2530	2740	2880	2070	2480	1940	2310	1730	2040	790	980	—	—
8V	DFC2	PUMP	300	1920	1820	1950	2410	2330	2480	1590	1900	1600	1950	2620	2980	2880	3390	890	1190
8V	None	None	330	2030	1920	2330	2220	2470	2440	2160	2290	760	890	—	—	—	—	—	—
8V	TDFC	None	330	1840	1870	2530	2510	2450	2620	2380	2700	1700	1760	1430	2240	—	—	—	—
8V	TDFC	Pump	330	1990	1960	2100	2030	2640	2710	1370	1970	1790	1930	2670	2810	2570	3270	—	—
9V	None	None	330	2050	1990	2970	2890	3050	3130	1730	1840	560	560	—	—	—	—	—	—
9V	TDFC	None	330	1810	1810	2570	2620	2650	2900	2690	3390	2230	2870	1090	1270	—	—	—	—
9V	TDFC	Pump	330	2170	2150	1980	1990	2910	2940	2260	3320	1670	1920	3010	3450	1850	2110	—	—
9V	DFC1	None	330	2290	2320	2000	1970	2590	2650	1680	2390	1000	1090	1560	1790	2250	3110	—	—
9V	DFC1	Pump	330	2070	1900	2120	2540	2530	2630	1720	2010	1720	2040	2670	2990	2700	3240	630	950
9V	NONE	—	375	1470	1690	1660	1820	2260	2290	2390	2170	2210	1870	1800	1630	—	—	—	—
9V	NONE	—	440	1470	1690	1660	1820	2260	2290	2390	2170	2210	1870	1800	1630	—	—	—	—
11V	NONE	—	380	2070	2340	1760	1940	2170	2200	2270	2050	2240	1900	2330	2230	—	—	—	—
11V	NONE	—	450	2070	2340	1760	1940	2170	2200	2270	2050	2240	1900	2330	2230	—	—	—	—
11V	NONE	—	500	2110	2330	1830	1980	2280	2380	2490	2560	2470	2550	2440	2480	—	—	—	—
11V	NONE	—	550	2110	2330	1830	1980	2280	2380	2490	2560	2470	2550	2440	2480	—	—	—	—
11V	TDFC	—	380	2380	3080	2400	2960	2840	3240	2720	2840	2310	2360	2830	3240	—	—	—	—
11V	TDFC	—	450	2380	3080	2400	2960	2840	3240	2720	2840	2310	2360	2830	3240	—	—	—	—
11V	TDFC	—	500	2440	3020	2520	3000	3000	3410	2970	3370	2530	2890	2970	3380	—	—	—	—

Table 19. Point weights - I-P (lb) (continued)

Cond ^(a)	Free-Cooling ^(b)	Pump ^(c)	Unit Size	Mounting Location																
				1	2	3	4	5	6	7	8	9	10	11	12	13	14	15	16	
11V	TDFC	—	550	2440	3020	2520	3000	3410	2970	3370	2530	2890	2970	3380	—	—	—	—	—	—
Standard Length Units with Options Box^(d)																				
11V	NONE	—	380	2330	3070	1870	1870	2190	2170	2290	2070	2240	1970	2980	2470	—	—	—	—	—
11V	NONE	—	450	2330	3070	1870	1870	2190	2170	2290	2070	2240	1970	2980	2470	—	—	—	—	—
11V	NONE	—	500	2370	3070	1920	1920	2310	2350	2510	2580	2450	2640	3060	2730	—	—	—	—	—
11V	NONE	—	550	2370	3070	1920	1920	2310	2350	2510	2580	2450	2640	3060	2730	—	—	—	—	—
11V	TDFC	—	380	2600	3600	2500	3160	2870	3300	2740	2870	2490	2470	3410	3490	—	—	—	—	—
11V	TDFC	—	450	2600	3600	2500	3160	2870	3300	2740	2870	2490	2470	3410	3490	—	—	—	—	—
11V	TDFC	—	500	2710	3560	2600	3140	3000	3400	2950	3350	2700	2960	3570	3660	—	—	—	—	—
11V	TDFC	—	550	2710	3560	2600	3140	3000	3400	2950	3350	2700	2960	3570	3660	—	—	—	—	—
Extended Length Units^(e)																				
4V	—	—	150	2270	2030	2240	2050	1890	2090	740	1010	—	—	—	—	—	—	—	—	—
4V	—	—	165	2280	2040	2250	2070	1910	2110	770	1030	—	—	—	—	—	—	—	—	—
4V	—	—	180	1220	1230	1870	1850	2720	2530	1550	1830	—	—	—	—	—	—	—	—	—
5V	NONE	—	180	2190	1970	2320	2210	2340	2590	770	970	—	—	—	—	—	—	—	—	—
5V	NONE	—	180	2150	1940	2390	2250	2430	2780	780	980	—	—	—	—	—	—	—	—	—
5V	NONE	—	200	2150	1950	2410	2260	2460	2800	790	980	—	—	—	—	—	—	—	—	—
5V	NONE	—	225	2260	1990	2660	2470	2700	3160	820	1090	—	—	—	—	—	—	—	—	—
5V	NONE	—	250	2290	2040	2710	2510	2760	3210	840	1110	—	—	—	—	—	—	—	—	—
5V	TDFC	—	165	2910	1840	3610	2560	3440	2870	1100	1670	—	—	—	—	—	—	—	—	—
5V	TDFC	—	180	2500	2440	3040	3210	2900	3300	1080	1830	—	—	—	—	—	—	—	—	—
5V	DFC1	—	165	3070	2990	2740	2650	2560	2540	990	2580	790	910	—	—	—	—	—	—	—
5V	DFC1	—	180	3080	3000	2780	2690	2620	2580	1010	2620	800	910	—	—	—	—	—	—	—
5V	DFC2	—	165	2950	2850	2620	2470	1860	2480	1820	2700	1230	1640	—	—	—	—	—	—	—
5V	DFC2	—	180	2960	2870	2670	2510	1910	2530	1860	2740	1230	1640	—	—	—	—	—	—	—
6V	NONE	—	200	2590	2380	2360	2290	2040	2250	740	860	620	700	—	—	—	—	—	—	—
6V	NONE	—	225	2810	2480	2620	2470	2240	2520	790	970	610	750	—	—	—	—	—	—	—
6V	NONE	—	250	2850	2520	2700	2550	2320	2590	810	990	600	730	—	—	—	—	—	—	—
6V	NONE	—	275	2860	2530	2720	2560	2340	2610	810	990	600	730	—	—	—	—	—	—	—
6V	TDFC	—	200	2720	2640	2790	2760	2810	2850	1130	2260	1150	1290	—	—	—	—	—	—	—
6V	TDFC	—	225	2930	2770	3050	2810	3020	2750	1190	2820	1190	1270	—	—	—	—	—	—	—

Table 19. Point weights - I-P (lb) (continued)

Cond ^(a)	Free-Cooling ^(b)	Pump ^(c)	Unit Size	Mounting Location															
				1	2	3	4	5	6	7	8	9	10	11	12	13	14	15	16
6V	TDFC	—	250	2970	2820	3140	2890	3110	2840	1200	2850	1160	1220	—	—	—	—	—	—
6V	TDFC	—	275	3330	3090	2910	2930	2340	2870	2030	2760	870	1350	—	—	—	—	—	—
6V	DFC1	—	200	3090	2910	2920	2700	2130	2850	2090	3150	1340	1790	—	—	—	—	—	—
6V	DFC1	—	225	3100	2920	2970	2740	2190	2910	2140	3200	1340	1790	—	—	—	—	—	—
6V	DFC1	—	250	3110	2930	2990	2750	2200	2920	2150	3210	1340	1790	—	—	—	—	—	—
6V	DFC2	—	200	3000	2940	2620	1990	1820	2620	1760	1930	1810	2550	1230	1950	—	—	—	—
6V	DFC2	—	225	3020	2970	2690	2030	1880	2690	1800	1970	1830	2580	1230	1940	—	—	—	—
6V	DFC2	—	250	3020	2970	2700	2040	1890	2700	1810	1970	1840	2580	1220	1940	—	—	—	—
7V	NONE	—	275	2700	2400	2400	2490	2500	2740	1000	1210	1020	1140	—	—	—	—	—	—
7V	TDFC	—	275	2920	2700	2780	2830	2490	3000	2470	3410	1600	2340	—	—	—	—	—	—
7V	DFC1	—	275	2970	2920	2630	1990	1850	2630	1810	1950	1920	2620	1700	2470	—	—	—	—
7V	DFC1	PUMP	275	2990	2970	2500	2090	2180	2090	1570	2610	1230	1440	2590	2840	2620	3550	—	—
7V	DFC2	—	275	2630	2240	2770	2910	2610	2980	2510	3070	1880	2840	910	1090	—	—	—	—
7V	DFC2	PUMP	275	2820	2420	2320	2440	2800	3220	2480	3190	2360	2970	2370	2790	940	1090	—	—
7V	NONE	—	300	2710	2400	2630	2500	2510	2750	1000	1210	1020	1140	—	—	—	—	—	—
7V	TDFC	—	300	3120	2930	3020	2780	2240	2960	2230	3290	1730	2180	—	—	—	—	—	—
8V	NONE	—	300	2890	2490	2780	2580	2290	2480	1820	2090	710	810	—	—	—	—	—	—
8V	TDFC	—	300	2710	2630	2530	1900	1900	2660	1950	2030	2120	2810	1920	2740	—	—	—	—
8V	TDFC	PUMP	300	2860	2570	1980	1920	2410	2650	1730	2600	1350	1490	2800	2970	2680	3450	—	—
8V	DFC1	—	300	2630	2240	2770	2910	2620	2980	2550	3100	2020	3000	1150	1320	—	—	—	—
8V	DFC1	PUMP	300	2620	2530	2770	2280	2630	3190	2580	3280	2070	3300	2760	2560	1100	1410	—	—
8V	DFC2	—	300	2860	2390	2130	2350	2010	2480	1820	2380	1320	1740	1900	2540	1490	1590	700	700
8V	DFC2	PUMP	300	1860	2860	1900	3600	1450	2860	1040	2100	1040	2700	2140	3800	2600	4170	800	1180
8V	None	None	330	3080	2700	2620	2410	2350	2550	2070	2360	770	880	—	—	—	—	—	—
8V	TDFC	None	330	3020	2970	2730	2060	1940	2750	1920	2030	2040	2740	1800	2590	—	—	—	—
8V	TDFC	Pump	330	3250	2970	2170	2100	2500	2760	1730	2630	1320	1470	2690	2880	2580	3330	—	—
9V	None	None	330	2830	2510	3570	3360	2870	3280	1550	1710	520	500	—	—	—	—	—	—
9V	TDFC	None	330	2860	2560	2820	2770	2580	2990	2470	3310	1990	2660	1430	1700	—	—	—	—
9V	TDFC	Pump	330	2980	2780	2430	2340	3100	3170	2360	3160	1810	2990	2850	3060	1440	1490	—	—
9V	DFC1	None	330	3200	2900	2890	2880	2020	2360	1350	1650	1190	1880	1760	1890	1370	1880	560	720
9V	DFC1	Pump	330	3130	2850	2830	2810	2020	2340	1460	1730	1460	2190	2950	2940	2470	3280	730	930

Table 19. Point weights - I-P (lb) (continued)

Cond ^(a)	Free-Cooling ^(b)	Pump ^(c)	Unit Size	Mounting Location															
				1	2	3	4	5	6	7	8	9	10	11	12	13	14	15	16
10V	NONE	—	375	2180	2730	2290	2500	2440	2360	2450	2050	2050	2220	1800	1550	1330	—	—	—
10V	NONE	—	440	2180	2730	2290	2500	2440	2360	2450	2050	2050	2220	1800	1550	1330	—	—	—

Notes:

1. Weights include factory charge of refrigerant and oil, ultimate sounds, and architectural louvered panels.
 2. All weights are plus/minus 10%.
- (a) Condenser length defined by model number digit 25: 4V = A; 5V = B; 6V = C; 7V = D; 8V = E; 9V = F; 11V = H.
 (b) Free-cooling defined by model number digit 42: T=TDFC; H=DFC2; J=DFC1.
 (c) Pump Package defined by model number digit 40 = 5, 6, 7.
 (d) Options box is used for units with either 575V (model number digit 9 = F) or Low Harmonics Option (model number digit 44 = L).
 (e) Extended Length is required for voltages 200V, 230V, 575V model number digit 9=A,B,F and harmonic filtration model number digit 44=L.

Table 20. Point weights - SI (kg)

Cond ^(a)	Free-Cooling ^(b)	Pump ^(c)	Unit Size	Mounting Location (kg)															
				Standard Length Units															
				1	2	3	4	5	6	7	8	9	10	11	12	13	14	15	16
4V	—	—	150	830	730	850	770	780	810	340	430	—	—	—	—	—	—		
4V	—	—	165	830	740	850	780	790	820	340	430	—	—	—	—	—	—		
4V	—	—	180	840	740	860	780	800	830	340	440	—	—	—	—	—	—		
5V	NONE	—	165	800	780	870	840	890	900	430	500	—	—	—	—	—	—		
5V	NONE	—	180	810	800	880	880	900	930	440	510	—	—	—	—	—	—		
5V	NONE	—	200	810	800	890	880	910	940	440	520	—	—	—	—	—	—		
5V	NONE	—	225	890	860	990	980	1010	1060	470	580	—	—	—	—	—	—		
5V	NONE	—	250	890	860	990	980	1010	1060	470	580	—	—	—	—	—	—		
5V	TDFC	—	165	780	660	1160	980	1340	1150	890	850	—	—	—	—	—	—		
5V	TDFC	—	180	960	1010	1100	1170	1160	1250	650	820	—	—	—	—	—	—		
5V	DFC1	—	165	870	900	1070	1150	1130	1270	800	1090	160	270	—	—	—	—		
5V	DFC1	—	180	830	920	1130	1180	1370	1310	480	1110	330	270	—	—	—	—		
5V	DFC2	—	165	780	780	900	950	990	1100	1060	1330	470	710	—	—	—	—		
5V	DFC2	—	180	810	810	950	1010	1070	1170	1140	1400	490	730	—	—	—	—		
6V	NONE	—	200	820	840	910	870	890	890	590	640	130	140	—	—	—	—		
6V	NONE	—	225	910	880	1020	970	960	970	630	710	130	150	—	—	—	—		
6V	NONE	—	250	930	900	1050	1000	990	990	630	710	130	150	—	—	—	—		
6V	NONE	—	275	940	910	1060	1020	1010	1000	640	720	130	150	—	—	—	—		
6V	TDFC	—	200	780	910	1180	1200	1370	1300	530	940	430	440	—	—	—	—		
6V	TDFC	—	225	890	900	1320	1320	1310	1410	780	990	310	440	—	—	—	—		
6V	TDFC	—	250	980	1020	1150	1190	1590	1690	540	570	430	690	—	—	—	—		
6V	TDFC	—	275	840	890	1330	1370	1490	1510	540	1090	420	430	—	—	—	—		
6V	DFC1	—	200	770	740	1080	1100	1120	1250	1160	1520	610	860	—	—	—	—		
6V	DFC1	—	225	780	750	1100	1130	1150	1270	1180	1540	610	860	—	—	—	—		
6V	DFC1	—	250	780	750	1100	1130	1160	1280	1180	1540	610	860	—	—	—	—		
6V	DFC2	—	200	760	780	1100	1080	1160	1170	910	1250	820	1070	350	—	—	—		
6V	DFC2	—	225	770	790	1120	1100	1190	1190	920	1260	820	1070	350	—	—	—		
6V	DFC2	—	250	770	790	1120	1110	1190	1190	920	1260	820	1070	350	—	—	—		
7V	NONE	—	275	890	840	960	910	930	920	840	920	400	440	—	—	—	—		
7V	NONE	—	300	890	840	970	910	930	920	840	930	400	440	—	—	—	—		

Table 20. Point weights - SI (kg) (continued)

Cond ^(a)	Free-Cooling ^(b)	Pump ^(c)	Unit Size	Mounting Location (kg)															
				1	2	3	4	5	6	7	8	9	10	11	12	13	14	15	16
7V	TDFC	—	275	820	810	1140	1230	1160	1240	1060	1360	790	1170	—	—	—	—	—	
7V	TDFC	—	300	810	790	1130	1150	1160	1290	1200	1560	770	1020	—	—	—	—	—	
7V	DFC1	—	275	880	800	1020	1100	1080	1200	1090	1300	770	890	690	—	—	—	—	
7V	DFC1	PUMP	275	920	910	940	900	1140	1180	590	850	770	840	1160	1230	1130	1440	—	
7V	DFC2	—	275	720	740	1130	1140	1310	1300	1150	1580	990	1310	260	300	—	—	—	
7V	DFC2	PUMP	275	710	740	1250	1230	1230	1250	890	1310	1070	1240	1100	1280	570	680	—	
8V	NONE	—	300	910	880	1060	1020	1070	1050	890	940	340	400	—	—	—	—	—	
8V	NONE	NONE	300	900	880	1060	1020	1070	1050	880	930	340	390	—	—	—	—	—	
8V	TDFC	NONE	300	800	810	1100	1110	1100	1210	1110	1320	810	880	580	790	—	—	—	
8V	TDFC	PUMP	300	880	890	900	900	1120	1190	590	870	780	860	1200	1270	1180	1550	—	
8V	DFC1	—	300	780	770	1140	1170	1200	1310	1240	1560	1020	1320	330	410	—	—	—	
8V	DFC1	PUMP	300	800	820	1060	1030	1320	1360	920	1350	1090	1260	1130	1300	680	790	—	
8V	DFC2	—	300	870	800	920	1140	1230	1300	920	1120	880	1040	790	930	390	460	—	
8V	DFC2	PUMP	300	870	810	880	1080	1060	1120	730	860	730	880	1180	1350	1350	1550	550	
8V	None	NONE	330	920	870	1060	1010	1120	1110	980	1040	350	410	—	—	—	—	—	
8V	TDFC	NONE	330	840	850	1150	1140	1120	1190	1080	1230	780	800	650	1020	—	—	—	
8V	TDFC	Pump	330	900	890	960	920	1200	1230	620	900	810	880	1210	1280	1170	1490	—	
9V	None	NONE	330	930	900	1350	1310	1390	1420	790	840	260	260	—	—	—	—	—	
9V	TDFC	NONE	330	820	820	1170	1190	1210	1320	1220	1540	1020	1300	500	580	—	—	—	
9V	TDFC	Pump	330	990	980	900	900	1320	1330	1030	1510	760	870	1370	1570	840	960	—	
9V	DFC1	NONE	330	1040	1050	910	900	1180	1210	760	1090	460	500	710	810	1030	1410	—	
9V	DFC1	Pump	330	940	870	960	1160	1150	1190	780	920	780	930	1210	1360	1230	1470	440	
9V	NONE	—	375	670	770	760	830	1020	1040	1090	980	1000	850	820	740	—	—	—	
9V	NONE	—	440	670	770	760	830	1020	1040	1090	980	1000	850	820	740	—	—	—	
11V	NONE	—	380	940	1050	810	880	980	1000	1040	930	1020	850	1070	1000	—	—	—	
11V	NONE	—	450	940	1050	810	880	980	1000	1040	930	1020	850	1070	1000	—	—	—	
11V	NONE	—	500	960	1060	830	900	1040	1070	1130	1170	1120	1160	1100	1120	—	—	—	
11V	NONE	—	550	960	1060	830	900	1040	1070	1130	1170	1120	1160	1100	1120	—	—	—	
11V	TDFC	—	380	1070	1390	1090	1350	1280	1470	1240	1280	1050	1080	1290	1470	—	—	—	
11V	TDFC	—	450	1070	1390	1090	1350	1280	1470	1240	1280	1050	1080	1290	1470	—	—	—	
11V	TDFC	—	500	1110	1360	1150	1360	1360	1550	1350	1520	1150	1310	1340	1540	—	—	—	

Table 20. Point weights - SI (kg) (continued)

Cond(a)	Free-Cooling(b)	Pump(c)	Unit Size	Mounting Location (kg)																
				1	2	3	4	5	6	7	8	9	10	11	12	13	14	15	16	
11V	TDFC	—	550	1110	1360	1150	1360	1360	1550	1350	1520	1150	1310	1340	1540	—	—	—	—	—
Standard Length Units with Options Box(d)																				
11V	NONE	—	380	1060	1400	850	860	1000	990	1030	940	1020	900	1350	1120	—	—	—	—	—
11V	NONE	—	450	1060	1400	850	860	1000	990	1030	940	1020	900	1350	1120	—	—	—	—	—
11V	NONE	—	500	1080	1400	870	870	1050	1060	1140	1180	1110	1200	1400	1240	—	—	—	—	—
11V	NONE	—	550	1080	1400	870	870	1050	1060	1140	1180	1110	1200	1400	1240	—	—	—	—	—
11V	TDFC	—	380	1190	1630	1130	1420	1300	1500	1250	1300	1130	1110	1550	1590	—	—	—	—	—
11V	TDFC	—	450	1190	1630	1130	1420	1300	1500	1250	1300	1130	1110	1550	1590	—	—	—	—	—
11V	TDFC	—	500	1220	1620	1170	1430	1350	1560	1340	1520	1220	1350	1620	1660	—	—	—	—	—
11V	TDFC	—	550	1220	1620	1170	1430	1350	1560	1340	1520	1220	1350	1620	1660	—	—	—	—	—
Extended Length Units(e)																				
4V	—	—	150	1030	920	1020	930	860	950	340	460	—	—	—	—	—	—	—	—	—
4V	—	—	165	1040	940	1030	940	870	960	340	460	—	—	—	—	—	—	—	—	—
4V	—	—	180	555	560	855	835	1240	1150	700	825	—	—	—	—	—	—	—	—	—
5V	NONE	—	165	990	900	1060	1010	1070	1180	350	440	—	—	—	—	—	—	—	—	—
5V	NONE	—	180	980	880	1080	1020	1100	1260	350	450	—	—	—	—	—	—	—	—	—
5V	NONE	—	200	980	880	1090	1030	1110	1270	360	450	—	—	—	—	—	—	—	—	—
5V	NONE	—	225	1030	900	1210	1120	1230	1440	370	500	—	—	—	—	—	—	—	—	—
5V	NONE	—	250	1040	920	1230	1140	1260	1460	370	500	—	—	—	—	—	—	—	—	—
5V	TDFC	—	165	1320	840	1635	1165	1560	1310	495	755	—	—	—	—	—	—	—	—	—
5V	TDFC	—	180	1130	1110	1380	1450	1320	1490	500	830	—	—	—	—	—	—	—	—	—
5V	DFC1	—	165	1390	1360	1250	1200	1160	1150	450	1170	360	420	—	—	—	—	—	—	—
5V	DFC1	—	180	1400	1360	1270	1220	1190	1170	460	1190	360	420	—	—	—	—	—	—	—
5V	DFC2	—	165	1340	1300	1190	1120	850	1130	830	1230	560	740	—	—	—	—	—	—	—
5V	DFC2	—	180	1350	1300	1210	1140	870	1150	850	1250	560	740	—	—	—	—	—	—	—
6V	NONE	—	200	1180	1080	1070	1040	930	1020	340	390	280	320	—	—	—	—	—	—	—
6V	NONE	—	225	1280	1130	1190	1120	1020	1140	360	440	280	340	—	—	—	—	—	—	—
6V	NONE	—	250	1300	1150	1230	1160	1050	1180	370	450	280	330	—	—	—	—	—	—	—
6V	NONE	—	275	1300	1150	1240	1170	1060	1190	370	450	280	330	—	—	—	—	—	—	—
6V	TDFC	—	200	1230	1190	1280	1260	1270	1290	530	1020	520	580	—	—	—	—	—	—	—
6V	TDFC	—	225	1330	1260	1380	1280	1370	1250	540	1270	540	580	—	—	—	—	—	—	—

Table 20. Point weights - SI (kg) (continued)

Cond ^(a)	Free-Cooling ^(b)	Pump ^(c)	Unit Size	Mounting Location (kg)															
				1	2	3	4	5	6	7	8	9	10	11	12	13	14	15	16
6V	TDFC	—	250	1350	1270	1420	1320	1420	1280	550	1290	530	550	—	—	—	—	—	—
6V	TDFC	—	275	1510	1400	1320	1330	1060	1310	920	1250	400	610	—	—	—	—	—	—
6V	DFC1	—	200	1400	1320	1330	1230	970	1300	950	1430	610	820	—	—	—	—	—	—
6V	DFC1	—	225	1410	1330	1350	1250	1000	1320	970	1450	610	820	—	—	—	—	—	—
6V	DFC1	—	250	1410	1330	1360	1250	1000	1330	980	1460	610	820	—	—	—	—	—	—
6V	DFC2	—	200	1360	1340	1190	900	830	1190	800	880	820	1160	560	890	—	—	—	—
6V	DFC2	—	225	1370	1350	1220	920	860	1220	820	890	830	1170	560	880	—	—	—	—
6V	DFC2	—	250	1370	1350	1230	930	860	1230	820	900	840	1170	560	880	—	—	—	—
7V	NONE	—	275	1230	1090	1190	1130	1140	1250	450	550	460	520	—	—	—	—	—	—
7V	NONE	—	300	1230	1090	1190	1130	1140	1250	450	550	460	520	—	—	—	—	—	—
7V	TDFC	—	275	1330	1230	1260	1290	1130	1370	1130	1520	730	990	—	—	—	—	—	—
7V	TDFC	—	300	1420	1330	1370	1260	1020	1340	1010	1490	790	990	—	—	—	—	—	—
7V	DFC1	—	275	1350	1330	1200	900	840	1200	830	890	870	1190	770	1130	—	—	—	—
7V	DFC1	PUMP	275	1360	1350	1140	950	990	950	710	1190	560	660	1180	1290	1190	1610	—	—
7V	DFC2	—	275	1190	1020	1260	1320	1190	1350	1140	1400	860	1290	420	500	—	—	—	—
7V	DFC2	PUMP	275	1280	1100	1050	1110	1270	1460	1130	1450	1070	1350	1080	1270	430	500	—	—
8V	NONE	NONE	300	1310	1130	1260	1170	1040	1120	830	950	320	370	—	—	—	—	—	—
8V	TDFC	NONE	300	1230	1200	1160	860	860	1210	880	920	960	1270	870	1240	—	—	—	—
8V	TDFC	PUMP	300	1300	1170	900	870	1090	1200	780	1180	610	680	1270	1350	1220	1560	—	—
8V	DFC1	NONE	300	1200	1020	1260	1320	1190	1360	1160	1410	920	1370	520	600	—	—	—	—
8V	DFC1	PUMP	300	1190	1150	1260	1040	1190	1450	1170	1490	940	1500	1260	1160	500	640	—	—
8V	DFC2	NONE	300	1310	1080	970	1060	920	1110	830	1070	610	780	870	1160	650	730	280	360
8V	DFC2	PUMP	300	850	1280	860	1590	660	1290	470	970	470	1230	970	1700	1200	1840	400	600
8V	None	NONE	330	1400	1230	1190	1100	1070	1160	940	1070	350	400	—	—	—	—	—	—
8V	TDFC	NONE	330	1370	1350	1240	940	880	1250	870	930	930	1250	820	1180	—	—	—	—
8V	TDFC	Pump	330	1480	1350	990	960	1140	1250	790	1190	600	670	1220	1310	1170	1510	—	—
9V	None	NONE	330	1290	1140	1620	1530	1310	1490	710	780	240	230	—	—	—	—	—	—
9V	TDFC	NONE	330	1300	1160	1280	1260	1170	1360	1120	1500	910	1210	650	770	—	—	—	—
9V	TDFC	Pump	330	1350	1260	1100	1060	1410	1440	1070	1440	820	1360	1300	1390	650	680	—	—
9V	DFC1	NONE	330	1440	1310	1310	1300	920	1070	610	740	540	850	800	860	620	850	250	330
9V	DFC1	Pump	330	1420	1290	1290	1280	920	1060	660	790	670	1000	1340	1340	1120	1490	330	420

Table 20. Point weights - SI (kg) (continued)

Cond ^(a)	Free-Cooling ^(b)	Pump ^(c)	Unit Size	Mounting Location (kg)															
				1	2	3	4	5	6	7	8	9	10	11	12	13	14	15	16
10V	NONE	—	375	990	1240	1040	1130	1110	1070	1110	1110	920	1010	820	700	610	—	—	—
10V	NONE	—	440	990	1240	1040	1130	1110	1070	1110	1110	920	1010	820	700	610	—	—	—

Notes:

1. Weights include factory charge of refrigerant and oil, ultimate sounds, and architectural louvered panels.
 2. All weights are plus/minus 10%.
- (a) Condenser length defined by model number digit 25: 4V = A; 5V = B; 6V = C; 7V = D; 8V = E; 9V = F; 11V = H.
 (b) Free-cooling defined by model number digit 42: T=TDFC; H=DFC2; J=DFC1.
 (c) Pump Package defined by model number digit 40 = 5, 6, 7.
 (d) Options box is used for units with either 575V (model number digit 9 = F) or Low Harmonics Option (model number digit 44 = L).
 (e) Extended Length is required for voltages 200V, 230V, 575V model number digit 9=A,B,F and harmonic filtration model number digit 44=L.

Isolator Selections

Table 21. Elastomeric isolator selections

Cond ^(a)	Free-Cooling ^(b)	Pump ^(c)	Comp ^(d)	Isolator Position															
				1	2	3	4	5	6	7	8	9	10	11	12	13	14	15	16
Standard Length Units																			
4V	—	—	GP4V	Lime 63	Lime 63	Lime 63	Lime 63	Lime 63	Lime 63	Lime 63	Brown 61	Brown 61	—	—	—	—	—	—	
5V	—	—	GP4V	Lime 63	Lime 63	Lime 63	Lime 63	Lime 63	Lime 63	Lime 63	Brown 61	Brown 61	—	—	—	—	—	—	
5V	TDFC	—	GP4V	Lime 63	Lime 63	Char-coal 64	Char-coal 64	Char-coal 64	Char-coal 64	Char-coal 64	Lime 63	Lime 63	—	—	—	—	—	—	
5V	DFC1	—	GP4V	Lime 63	Lime 63	Char-coal 64	Char-coal 64	Char-coal 64	Char-coal 64	Char-coal 64	Lime 63	Lime 63	Brown 61	—	—	—	—	—	
5V	DFC2	—	GP4V	Lime 63	Lime 63	Char-coal 64	Char-coal 64	Char-coal 64	Char-coal 64	Char-coal 64	Lime 63	Lime 63	Lime 63	—	—	—	—	—	
6V	—	—	GP4V	Lime 63	Lime 63	Lime 63	Lime 63	Char-coal 64	Char-coal 64	Char-coal 64	Brown 61	Brown 61	—	—	—	—	—	—	
6V	TDFC	—	GP4V	Lime 63	Lime 63	Char-coal 64	Char-coal 64	Char-coal 64	Char-coal 64	Char-coal 64	Lime 63	Lime 63	—	—	—	—	—	—	
6V	DFC1	—	GP4V	Lime 63	Lime 63	Char-coal 64	Char-coal 64	Char-coal 64	Char-coal 64	Char-coal 64	Lime 63	Lime 63	Lime 63	—	—	—	—	—	
6V	DFC2	—	GP4V	Lime 63	Lime 63	Char-coal 64	Char-coal 64	Char-coal 64	Char-coal 64	Char-coal 64	Lime 63	Lime 63	Brown 61	—	—	—	—	—	
7V	—	—	GP4V	Lime 63	Lime 63	Lime 63	Lime 63	Lime 63	Lime 63	Lime 63	Lime 63	Lime 63	—	—	—	—	—	—	
7V	TDFC	—	GP4V	Lime 63	Lime 63	Char-coal 64	Char-coal 64	Char-coal 64	Char-coal 64	Char-coal 64	Char-coal 64	Char-coal 64	—	—	—	—	—	—	
7V	DFC1	None	GP4V	Char-coal 64	Lime 63	Char-coal 64	Char-coal 64	Char-coal 64	Char-coal 64	Char-coal 64	Char-coal 64	Char-coal 64	Lime 63	Lime 63	Lime 63	—	—	—	
7V	DFC1	Pump	GP4V	Lime 63	Lime 63	Lime 63	Lime 63	Char-coal 64	Char-coal 64	Char-coal 64	Lime 63	Lime 63	Lime 63	Lime 63	Lime 63	Char-coal 64	Char-coal 64	—	
7V	DFC2	None	GP4V	Lime 63	Lime 63	Char-coal 64	Char-coal 64	Char-coal 64	Char-coal 64	Char-coal 64	Lime 63	Lime 63	—	—	—	—	—	—	
7V	DFC2	Pump	GP4V	Brick Red 62	Brick Red 62	Char-coal 64	Char-coal 64	Char-coal 64	Char-coal 64	Char-coal 64	Lime 63	Lime 63	Char-coal 64	Char-coal 64	Char-coal 64	Lime 63	Lime 63	—	
8V	NONE	—	GP4V	Lime 63	Lime 63	Lime 63	Lime 63	Lime 63	Lime 63	Lime 63	Lime 63	Lime 63	—	—	—	—	—	—	
8V	TDFC	None	GP4V	Lime 63	Lime 63	Char-coal 64	Char-coal 64	Char-coal 64	Char-coal 64	Char-coal 64	Char-coal 64	Char-coal 64	Lime 63	Lime 63	Lime 63	—	—	—	
8V	TDFC	Pump	GP4V	Lime 63	Lime 63	Lime 63	Lime 63	Char-coal 64	Char-coal 64	Char-coal 64	Brick Red 62	Brick Red 62	Lime 63	Lime 63	Lime 63	Char-coal 64	Char-coal 64	—	
8V	DFC1	None	GP4V	Lime 63	Lime 63	Char-coal 64	Char-coal 64	Char-coal 64	Char-coal 64	Char-coal 64	Lime 63	Lime 63	—	—	—	—	—	—	
8V	DFC1	Pump	GP4V	Brick Red 62	Brick Red 62	Lime 63	Lime 63	Char-coal 64	Char-coal 64	Char-coal 64	Lime 63	Lime 63	Char-coal 64	Char-coal 64	Char-coal 64	Char-coal 64	Char-coal 64	—	
8V	DFC2	None	GP4V	Char-coal 64	Char-coal 64	Char-coal 64	Char-coal 64	Char-coal 64	Char-coal 64	Char-coal 64	Lime 63	Lime 63	—	—	—	—	—	—	
8V	DFC2	Pump	GP4V	Lime 63	Lime 63	Lime 63	Lime 63	Char-coal 64	Char-coal 64	Char-coal 64	Lime 63	Lime 63	Char-coal 64	Char-coal 64	Char-coal 64	Char-coal 64	Char-coal 64	Brown 61	

Table 21. Elastomeric isolator selections (continued)

Cond ^(a)	Free-Cooling ^(b)	Pump ^(c)	Comp ^(d)	Isolator Position															
				1	2	3	4	5	6	7	8	9	10	11	12	13	14	15	16
7V	DFC2	Pump	GP4V	—	—	—	—	—	—	—	—	—	—	—	—	—	—	—	
8V	NONE	—	GP4V	B-64	B-64	B-64	B-64	B-64	B-64	B-64	B-64	B-64	B-64	B-64	B-64	B-64	B-64	B-64	
8V	TDFC	None	GP4V	B-64	B-64	B-64	B-64	B-64	B-64	B-64	B-64	B-64	B-64	B-64	B-64	B-64	B-64	B-64	
8V	TDFC	Pump	GP4V	—	—	—	—	—	—	—	—	—	—	—	—	—	—	—	
8V	DFC1	None	GP4V	B-64	B-64	B-64	B-64	B-64	B-64	B-64	B-64	B-64	B-64	B-64	B-64	B-64	B-64	B-64	
8V	DFC1	Pump	GP4V	—	—	—	—	—	—	—	—	—	—	—	—	—	—	—	
8V	DFC2	None	GP4V	B-64	B-64	B-64	B-64	B-64	B-64	B-64	B-64	B-64	B-64	B-64	B-64	B-64	B-64	B-64	
8V	DFC2	Pump	GP4V	—	—	—	—	—	—	—	—	—	—	—	—	—	—	—	
9V	None	None	GP4V	B-64	B-64	B-64	B-64	B-64	B-64	B-64	B-64	B-64	B-64	B-64	B-64	B-64	B-64	B-64	
9V	TDFC	None	GP4V	B-64	B-64	B-64	B-64	B-64	B-64	B-64	B-64	B-64	B-64	B-64	B-64	B-64	B-64	B-64	
9V	TDFC	Pump	GP4V	—	—	—	—	—	—	—	—	—	—	—	—	—	—	—	
9V	DFC1	None	GP4V	B-64	B-64	B-64	B-64	B-64	B-64	B-64	B-64	B-64	B-64	B-64	B-64	B-64	B-64	B-64	
9V	DFC1	Pump	GP4V	—	—	—	—	—	—	—	—	—	—	—	—	—	—	—	
9V	—	—	GP4V	B-64	B-64	B-64	B-64	B-64	B-64	B-64	B-64	B-64	B-64	B-64	B-64	B-64	B-64	B-64	
9V	—	—	GP4V	B-64	B-64	B-64	B-64	B-64	B-64	B-64	B-64	B-64	B-64	B-64	B-64	B-64	B-64	B-64	
11V	—	—	GP4V	B-64	B-64	B-64	B-64	B-64	B-64	B-64	B-64	B-64	B-64	B-64	B-64	B-64	B-64	B-64	
11V ^(e)	—	—	GP4V	B-64	B-64	B-64	B-64	B-64	B-64	B-64	B-64	B-64	B-64	B-64	B-64	B-64	B-64	B-64	
11V	TDFC	—	GP4V	B-64	B-64	B-64	B-64	B-64	B-64	B-64	B-64	B-64	B-64	B-64	B-64	B-64	B-64	B-64	

Extended Length Units with Seismic/ Wind Load																		
4V	—	—	GP4V	B-64	B-64	B-64	B-64	B-64	B-64	B-64	B-64	B-64	B-64	B-64	B-64	B-64	B-64	B-64
5V	—	—	GP4V	B-64	B-64	B-64	B-64	B-64	B-64	B-64	B-64	B-64	B-64	B-64	B-64	B-64	B-64	B-64
5V	TDFC	—	GP4V	B-64	B-64	B-64	B-64	B-64	B-64	B-64	B-64	B-64	B-64	B-64	B-64	B-64	B-64	B-64
5V	DFC1	—	GP4V	B-64	B-64	B-64	B-64	B-64	B-64	B-64	B-64	B-64	B-64	B-64	B-64	B-64	B-64	B-64
5V	DFC2	—	GP4V	B-64	B-64	B-64	B-64	B-64	B-64	B-64	B-64	B-64	B-64	B-64	B-64	B-64	B-64	B-64
6V	—	—	GP4V	B-64	B-64	B-64	B-64	B-64	B-64	B-64	B-64	B-64	B-64	B-64	B-64	B-64	B-64	B-64
6V	TDFC	—	GP4V	B-64	B-64	B-64	B-64	B-64	B-64	B-64	B-64	B-64	B-64	B-64	B-64	B-64	B-64	B-64
6V	DFC1	—	GP4V	B-64	B-64	B-64	B-64	B-64	B-64	B-64	B-64	B-64	B-64	B-64	B-64	B-64	B-64	B-64
6V	DFC2	—	GP4V	B-64	B-64	B-64	B-64	B-64	B-64	B-64	B-64	B-64	B-64	B-64	B-64	B-64	B-64	B-64
7V	NONE	—	GP4V	B-64	B-64	B-64	B-64	B-64	B-64	B-64	B-64	B-64	B-64	B-64	B-64	B-64	B-64	B-64
7V	TDFC	—	GP4V	B-64	B-64	B-64	B-64	B-64	B-64	B-64	B-64	B-64	B-64	B-64	B-64	B-64	B-64	B-64
7V	DFC1	None	GP4V	B-64	B-64	B-64	B-64	B-64	B-64	B-64	B-64	B-64	B-64	B-64	B-64	B-64	B-64	B-64
7V	DFC1	Pump	GP4V	—	—	—	—	—	—	—	—	—	—	—	—	—	—	—
7V	DFC2	None	GP4V	B-64	B-64	B-64	B-64	B-64	B-64	B-64	B-64	B-64	B-64	B-64	B-64	B-64	B-64	B-64
7V	DFC2	Pump	GP4V	—	—	—	—	—	—	—	—	—	—	—	—	—	—	—
8V	NONE	—	GP4V	B-64	B-64	B-64	B-64	B-64	B-64	B-64	B-64	B-64	B-64	B-64	B-64	B-64	B-64	B-64
8V	TDFC	None	GP4V	B-64	B-64	B-64	B-64	B-64	B-64	B-64	B-64	B-64	B-64	B-64	B-64	B-64	B-64	B-64
8V	TDFC	Pump	GP4V	—	—	—	—	—	—	—	—	—	—	—	—	—	—	—
8V	DFC1	None	GP4V	B-64	B-64	B-64	B-64	B-64	B-64	B-64	B-64	B-64	B-64	B-64	B-64	B-64	B-64	B-64
8V	DFC1	Pump	GP4V	—	—	—	—	—	—	—	—	—	—	—	—	—	—	—
8V	DFC2	None	GP4V	B-64	B-64	B-64	B-64	B-64	B-64	B-64	B-64	B-64	B-64	B-64	B-64	B-64	B-64	B-64
8V	DFC2	Pump	GP4V	—	—	—	—	—	—	—	—	—	—	—	—	—	—	—
9V	None	None	GP4V	B-64	B-64	B-64	B-64	B-64	B-64	B-64	B-64	B-64	B-64	B-64	B-64	B-64	B-64	B-64
9V	TDFC	None	GP4V	B-64	B-64	B-64	B-64	B-64	B-64	B-64	B-64	B-64	B-64	B-64	B-64	B-64	B-64	B-64
9V	TDFC	Pump	GP4V	—	—	—	—	—	—	—	—	—	—	—	—	—	—	—
9V	DFC1	None	GP4V	B-64	B-64	B-64	B-64	B-64	B-64	B-64	B-64	B-64	B-64	B-64	B-64	B-64	B-64	B-64

Table 21. Elastomeric isolator selections (continued)

Cond ^(a)	Free-Cooling ^(b)	Pump ^(c)	Comp ^(d)	Isolator Position															
				1	2	3	4	5	6	7	8	9	10	11	12	13	14	15	16
9V	DFC1	Pump	GP4V	—	—	—	—	—	—	—	—	—	—	—	—	—	—	—	—
9V	—	—	GPMX	B-64	B-64	B-64	B-64	B-64	B-64	B-64	B-64	B-64	B-64	B-64	B-64	B-64	B-64	B-64	B-64

(a) Condenser length defined by model number digit 25: 4V = A; 5V = B; 6V = C; 7V = D; 8V = E; 9V = F; 11V = H.
 (b) Free-cooling defined by model number digit 42: T=IDFC; H=DFC2; J=DFC1.
 (c) Pump Package defined by model number digit 40 = 5, 6, 7.
 (d) Compressor type defined by model digit 8: 4 = GPMX, 5 = GP4V, or where harmonic filter = low (model number digit 44 = L).
 (e) 11V Units without Free Cooling, with Options Box. Options box is used for units with either unit voltage = 575V (model number digit 9 = F) or where harmonic filter = low (model number digit 44 = L).
 (f) Extended Length is required for voltages 200V, 230V, 380V, 400V, 575V model number digit 9=A,B,C,D, F and harmonic filtration model number digit 44=L

Compressor Mounting Bolt Removal

Units with InvisiSound™ Ultimate Option (Model Number Digit 13 = E)

For chillers built with InvisiSound Ultimate option, compressor mounting bolts must be removed to assure minimum noise during operation. Use a 24mm socket to remove the (3) M15 x 75mm mounting bolts for each

compressor. They are located under compressor mounting feet. See figure below.

Important:

- **DO NOT DISCARD MOUNTING BOLTS.** Store bolts in the control panel for future use.
- All mounting bolts **MUST** be reinstalled prior to compressor removal or unit move.

NOTICE

Equipment Damage!
 Failure to reinstall bolts could cause shifting of parts and result in equipment damage.
 Do not remove compressor or move unit without reattaching compressor mounting bolts.

Figure 17. Compressor mounting bolt removal

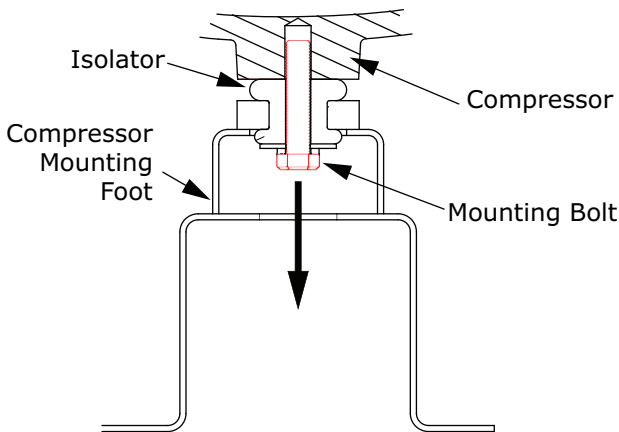
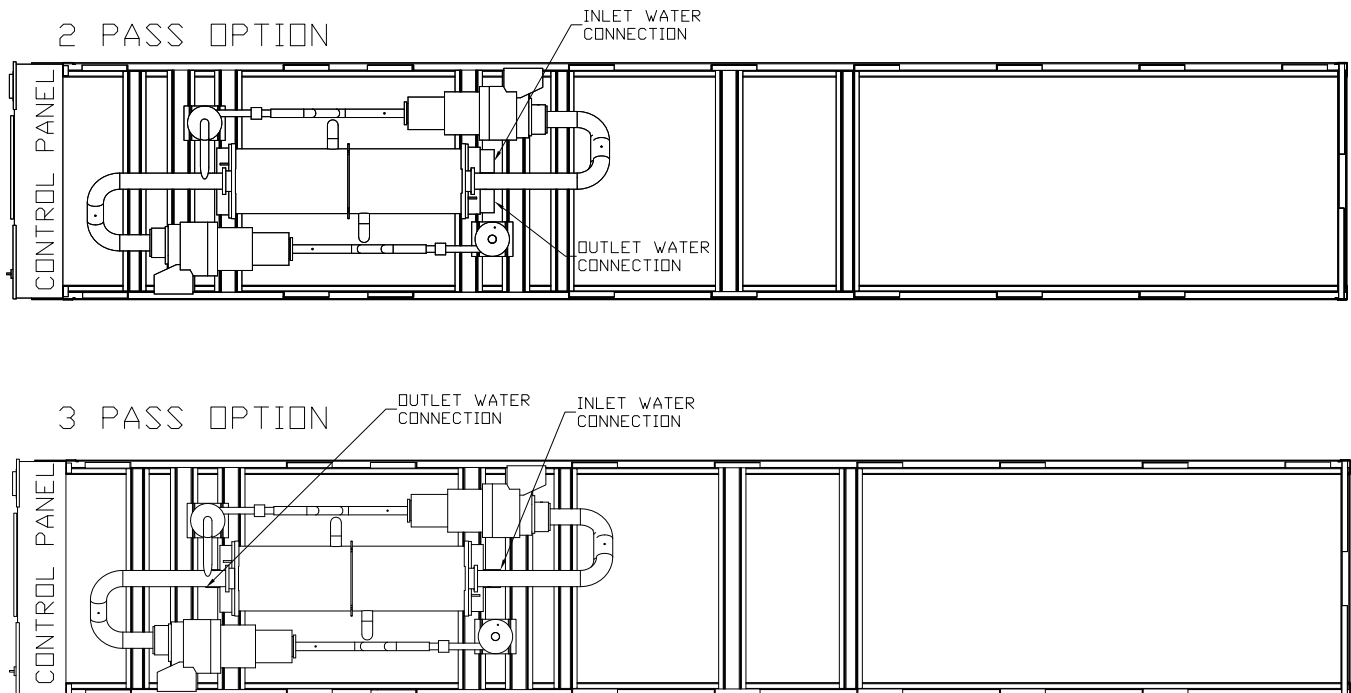

Figure 18. Evaporator pass configurations — two-compressor units



Drainage

Locate the unit near a large capacity drain for water vessel drain-down during shutdown or repair. Evaporators are provided with drain connections. A vent on top of evaporator waterbox prevents vacuum by allowing air into evaporator for complete drainage. All local and national codes apply.

Refrigerant Pressure Relief Valves

See General Data for refrigerant pressure relief valve information.

Evaporator Piping

Available pass configurations:

- Two-compressor units: Two or three passes
- Three- and Four-Compressor units: One or two passes

Note: The following figures are top views. Condenser removed for clarity.

Figure 19. Evaporator pass configurations — three- and four-compressor units

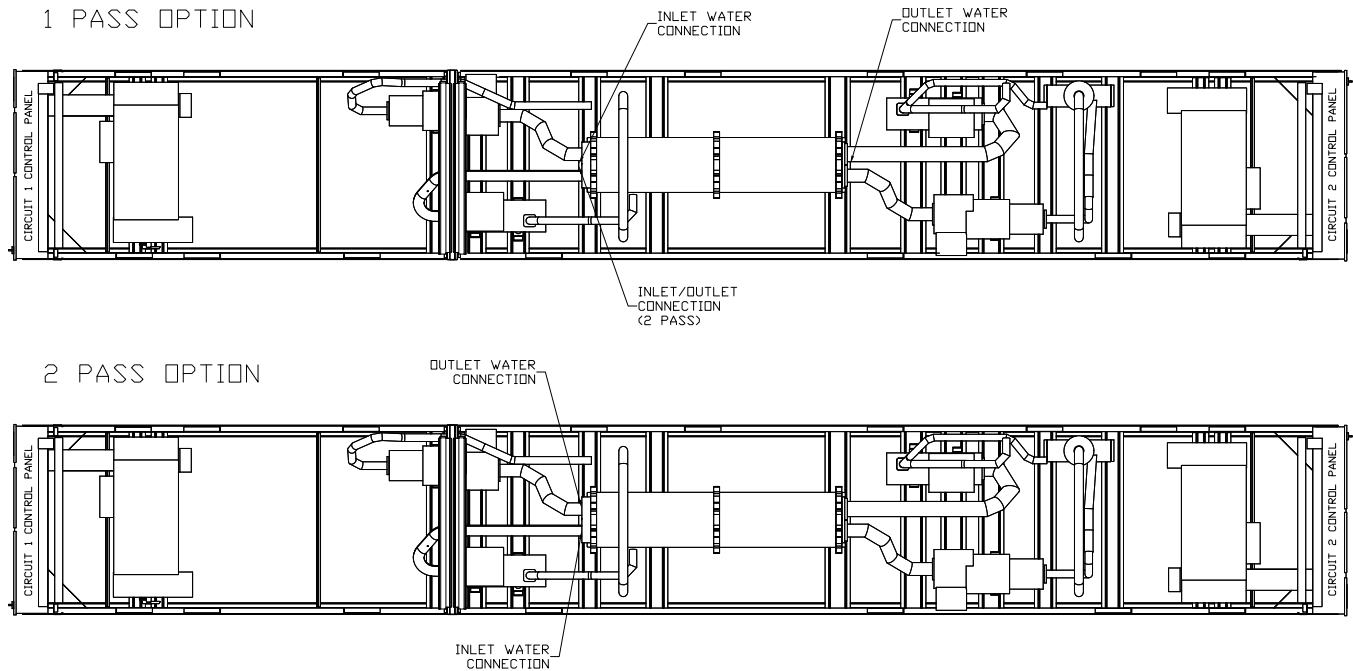

NOTICE

Proper Water Treatment Required!
 The use of untreated or improperly treated water could result in scaling, erosion, corrosion, algae or slime.
 Use the services of a qualified water treatment specialist to determine what water treatment, if any, is required. Trane assumes no responsibility for equipment failures which result from untreated or improperly treated water, or saline or brackish water.

NOTICE

Evaporator Damage!
 Failure to follow instructions below could cause damage to the evaporator.
 The chilled water connections to the evaporator are to be “victaulic” type connections. Do not attempt to weld these connections, as the heat generated from welding can cause microscopic and macroscopic fractures on the cast iron waterboxes that can lead to premature failure of the waterbox. To prevent damage to chilled water components, do not allow evaporator pressure (maximum working pressure) to exceed 150 psig (10.5 bar).

- Components and layout will vary slightly, depending on the location of connections and the water source.
- A vent is provided on the top of the evaporator at the chilled water inlet. Be sure to provide additional vents at high points in the piping to bleed air from the chilled water system. Install necessary pressure gauges to monitor the entering and leaving chilled water pressures.
- Provide shutoff valves in lines to the gauges to isolate them from the system when they are not in use. Use rubber vibration eliminators to prevent vibration transmission through the water lines.
- If desired, install thermometers in the lines to monitor entering and leaving water temperatures.
- Install a balancing valve in the leaving water line to control water flow balance.
- Install shutoff valves on both the entering and leaving water lines so that the evaporator can be isolated for service.

Evaporator Piping Components

Piping components include all devices and controls used to provide proper water system operation and unit operating safety. These components and their general locations are given below.

- Evaporator water connections are grooved.
- Thoroughly flush all water piping to the unit before making the final piping connections to the unit.

Figure 20. Typical water piping components

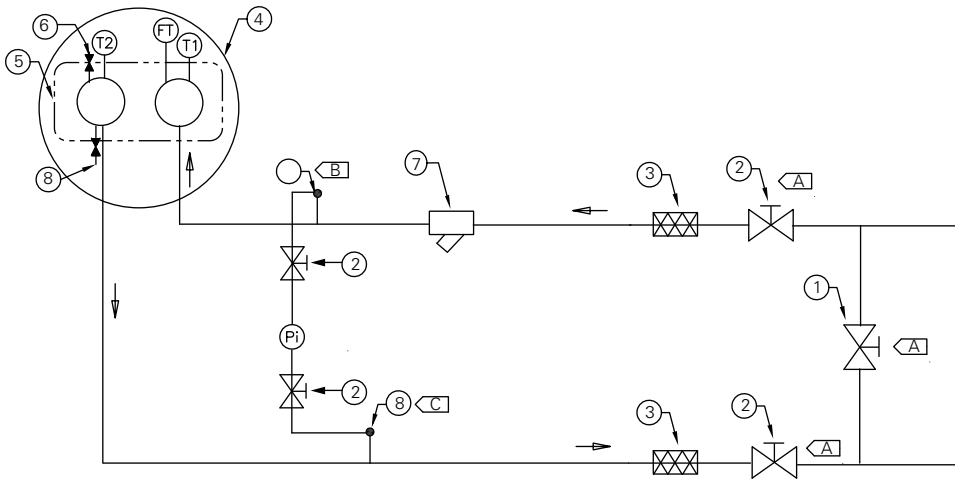

Item	Description	Item	Description
1	Bypass Valve	Pi	Pressure Gauge
2	Isolation Valve	FT	Water Flow Switch
3	Vibration Eliminator	T1	Evap Water Inlet Temp Sensor
4	Evaporator - End View (2-pass)	T2	Evap Water Outlet Temp Sensor
5	Evaporator Waterbox (2-pass)	NOTES	
6	Vent	A	Isolate unit for initial water loop cleaning
7	Strainer	B	Vent must be installed at the high point of the line
8	Drain	C	Drain must be installed at the low point of the line

Entering Chilled Water Piping

- Air vents (to bleed air from system).
- Water pressure gauges with shutoff valves.
- Vibration eliminators.
- Shutoff (isolation) valves.
- Thermometers (if desired).
- Clean-out tees.
- Pipe strainer.

Leaving Chilled Water Piping

- Air vents (to bleed air from system).
- Water pressure gauges with shutoff valves.
- Vibration eliminators.
- Shutoff (isolation) valves.
- Thermometers.
- Clean-out tees.
- Balancing valve.

Drains

A 1/2" drain connection is located under outlet end of evaporator waterbox for drainage during unit servicing. A shutoff valve must be installed on drain line.

Pressure Gauges

Install field-supplied pressure components as shown in figure above. Locate pressure gauges or taps in a straight run of pipe; avoid placement near elbows, etc. Be sure to install the gauges at the same elevation on each shell if the shells have opposite-end water connections.

To read manifolded pressure gauges, open one valve and close the other (depending upon the reading desired). This eliminates errors resulting from differently calibrated gauges installed at unmatched elevations.

Pressure Relief Valves

NOTICE

Evaporator Damage!

Failure to follow instructions below could cause damage to the evaporator.

To prevent evaporator damage, install pressure relief valves in the evaporator water system.

Install a water pressure relief valve in the evaporator inlet piping between the evaporator and the inlet shutoff valve, as shown in figure above. Water vessels with close-coupled shutoff valves have a high potential for hydrostatic pressure buildup on a water temperature increase. Refer to applicable codes for relief valve installation guidelines.

Evaporator Flow Switch

The flow switch is factory-installed and programmed based on the operating conditions submitted with the order. The leaving evaporator temperature, fluid type and fluid concentration affect the selected flow switch. If the operating conditions on the job site change, the flow switch may need to be replaced. Contact your local Trane Sales office for more information.

The sensor head includes 3 LEDs, two yellow and one green. Wait 15 seconds after power is applied to the sensor before evaluating LEDs for flow status. When wired correctly and flow is established, only the green LED should be lit. Following are the LED indicators:

- Green ON, both yellow OFF — Flow
- Green and outside yellow ON — No Flow
- Center yellow ON continuously — Miswire

Pump Package

The pump package contains a single pump, triple-duty valves, service isolation valves, pressure ports, air separator, expansion tank, and fluid strainer. Included is -20°F (-29°C) ambient freeze protection for water.

The pump skid contains an independent pump motor starter panel. The pump starter panel's power supply is

prewired into the chiller's control panel assembly. An independent pump motor supply is not required. Variable pump speed command is integrated with the chiller controller, allowing variable flow functionality. Harmonic filtration is standard.

Pump package applications include short loops, decoupled systems, and service for an entire loop volume. Because the fluid distribution system beyond the chiller is unknown, Trane Select Assist reports Available Head as the head leaving the chiller at the system supply connection point. Available Head includes the evaporator head loss, pump package and free-cooling piping frictional effects head losses, valve head losses, air separator head loss, and strainer head loss summation.

See [Figure 21, p. 60](#) for generally recommended field installed piping components and locations.

NOTICE

Equipment Damage!

Failure to follow instructions could result in equipment damage.

**Do not operate the pump package at $NPSH_R$.
Operation at this suction head will cause cavitation.
 $NPSH_A$ should be at least 1.5 to 2.5 times $NPSH_R$.**

Figure 21. Pump package schematic

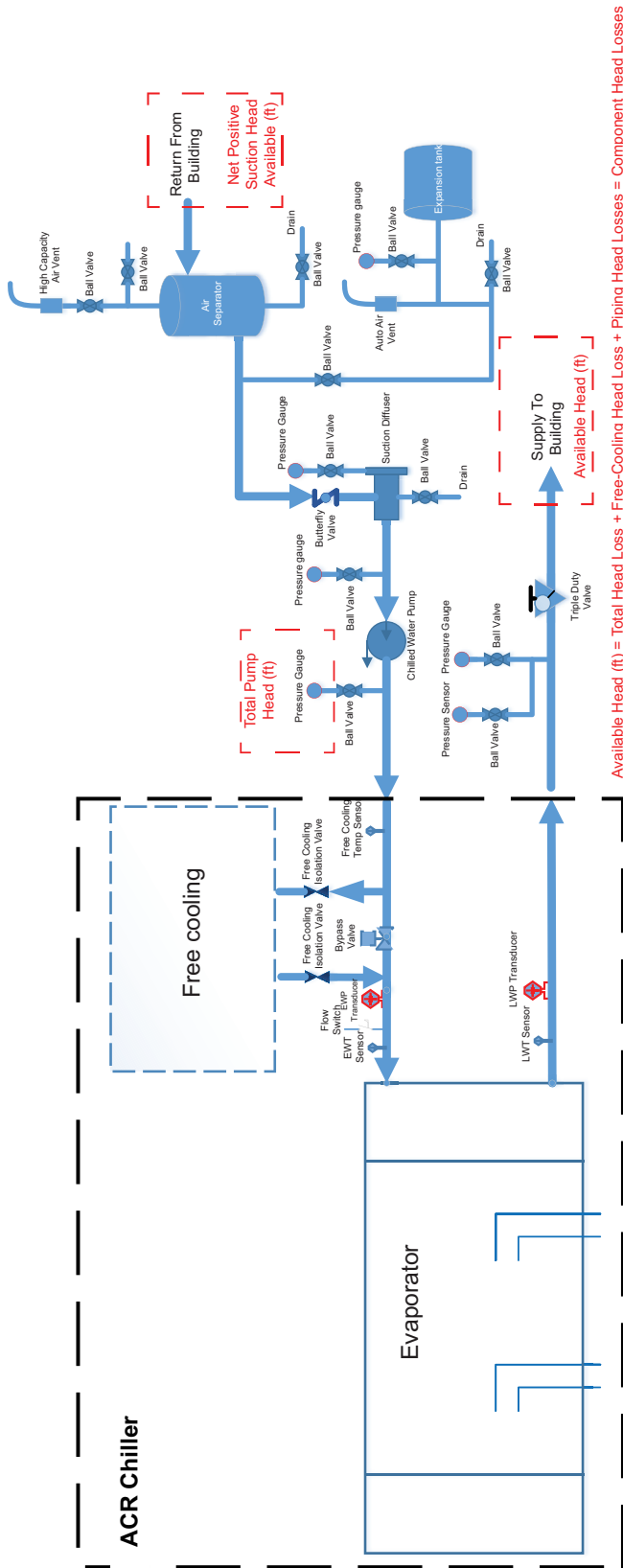

Available Head (ft) = Total Head Loss + Free-Cooling Head Loss + Piping Head Losses = Component Head Losses

Pump Package Available Head and Net Positive Suction Head Required

Select Assist to determine these values for applications with other freeze avoidance solutions.

Pump package available head and NPSH_R illustrated in these graphs are for the noted fluid types. Use Trane

Figure 22. ACR300 – 50hp pump package NPSH_R (water)

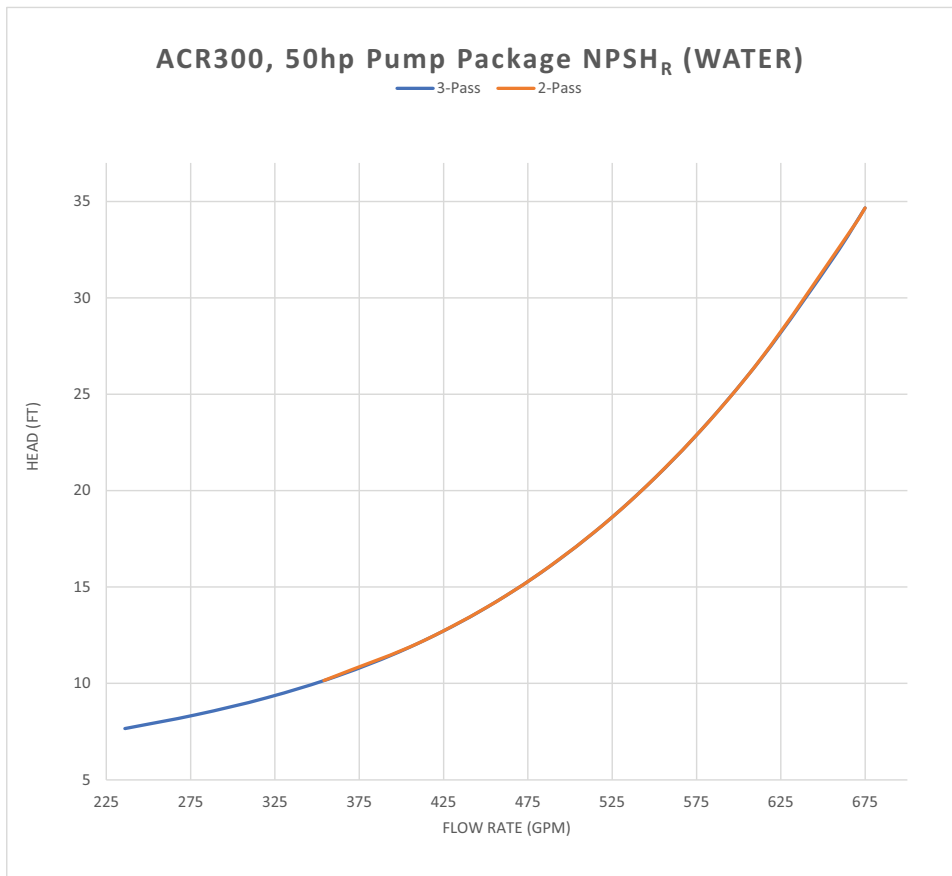

Figure 23. ACR300 – 50hp pump package available head, 8V condenser length

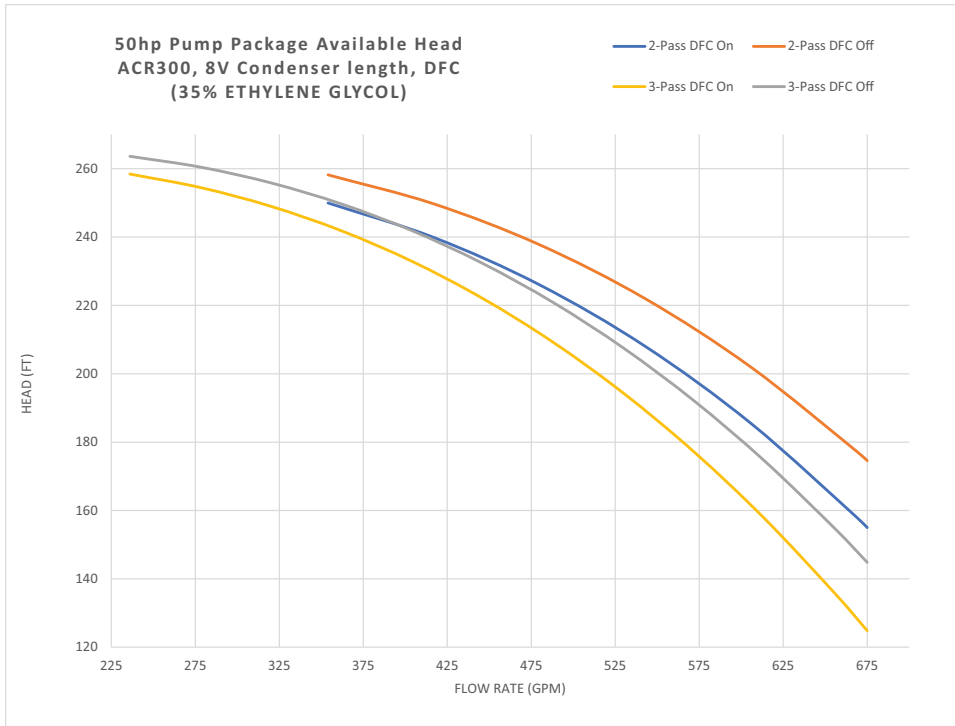

Figure 24. ACR300 – 50hp pump package available head, 10V condenser length

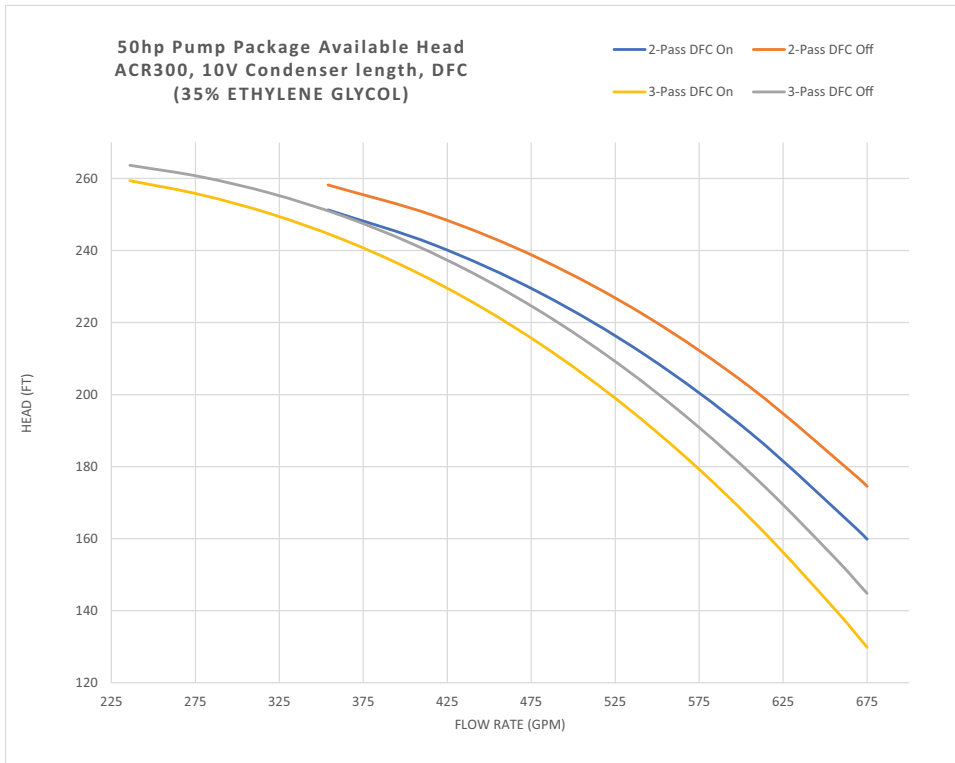

Figure 25. ACR300 – 50hp pump package available head, IFC (water)

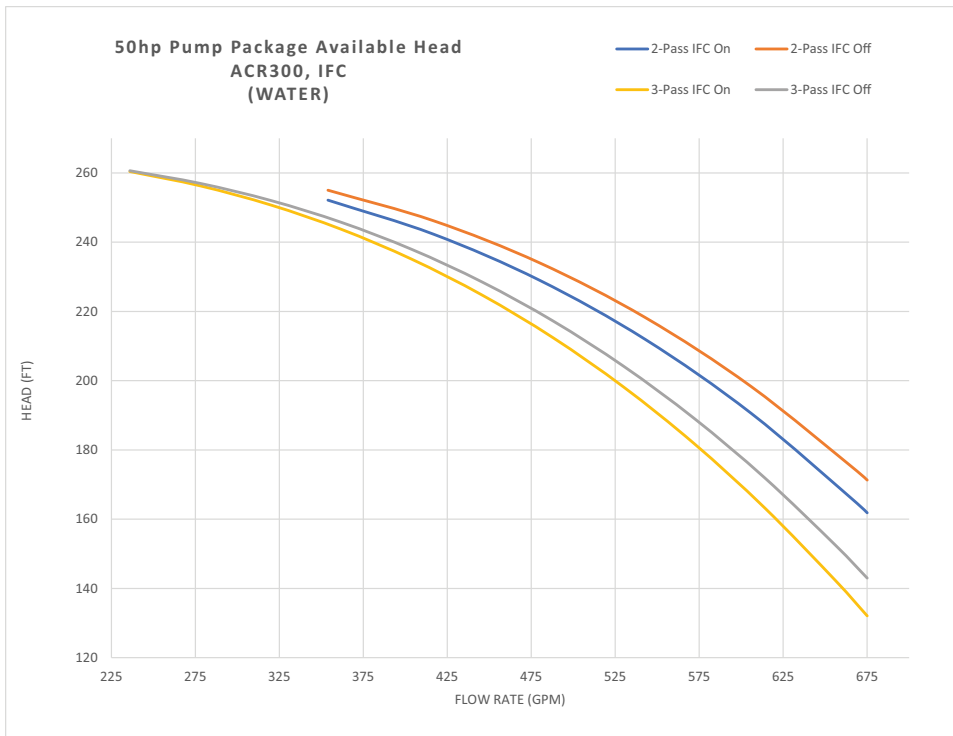

Figure 26. ACR300 –60hp pump package NPSH_R (water)

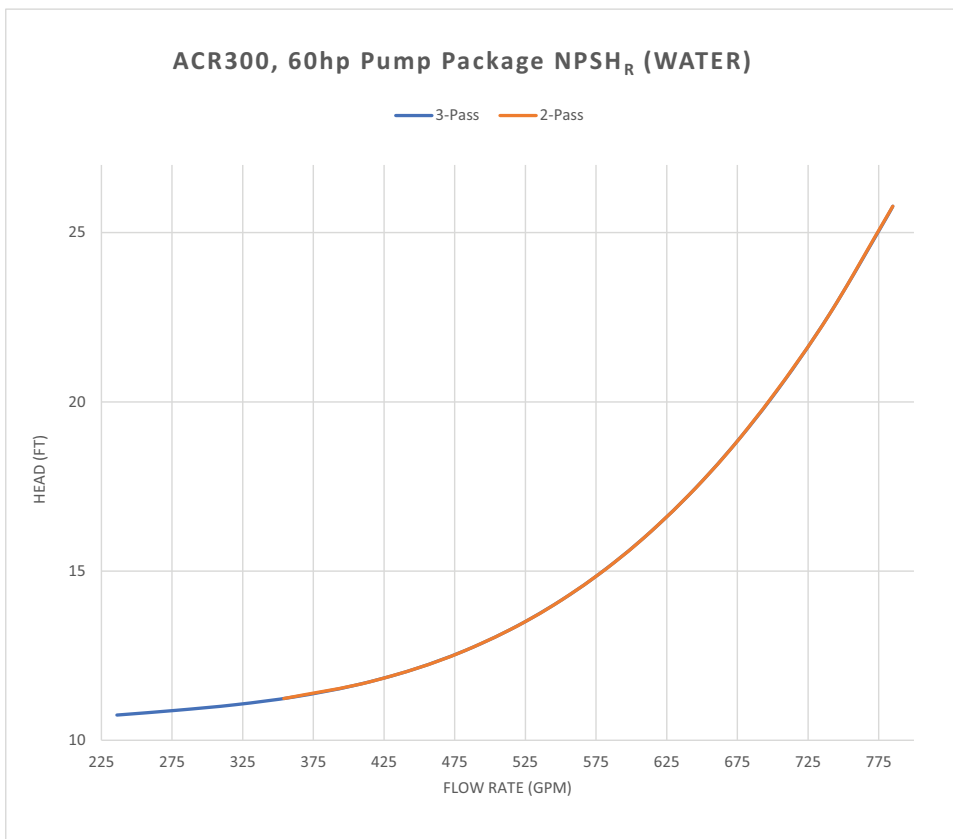

Figure 27. ACR300 – 60hp pump package available head, 8V condenser length

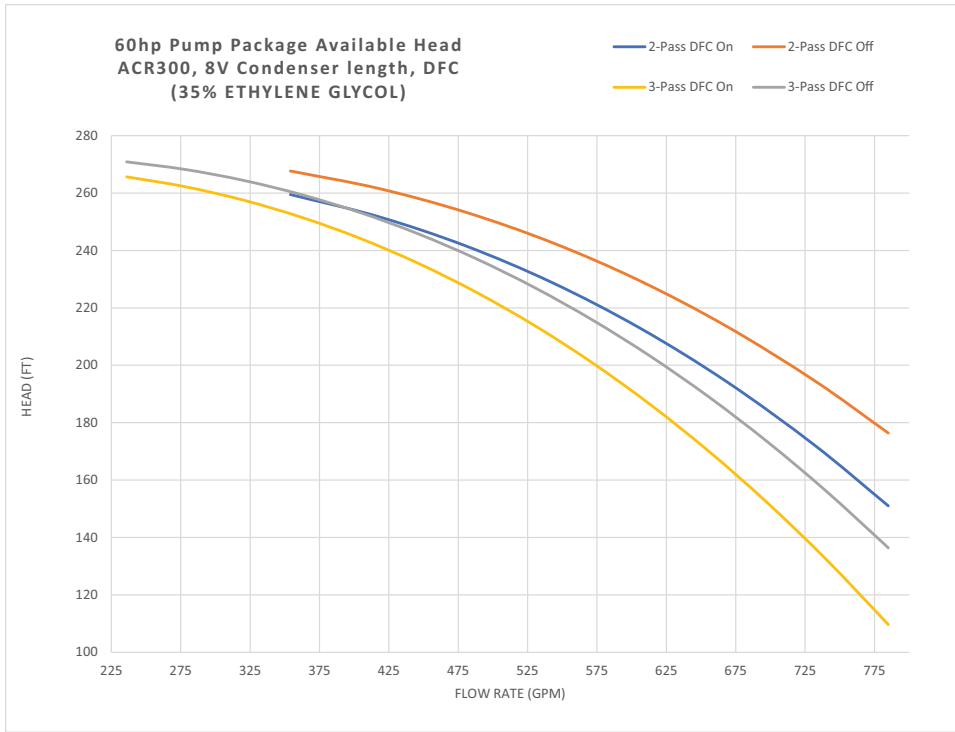

Figure 28. ACR300 – 60hp pump package available head, 10V condenser length

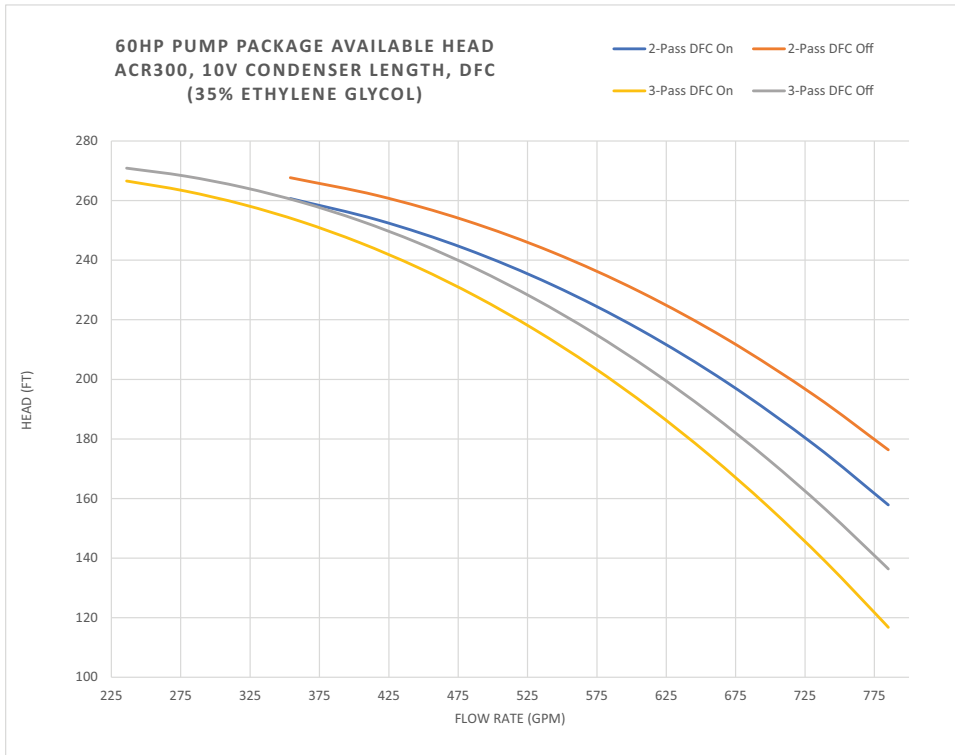

Figure 29. ACR300 – 60hp pump package available head, IFC (water)

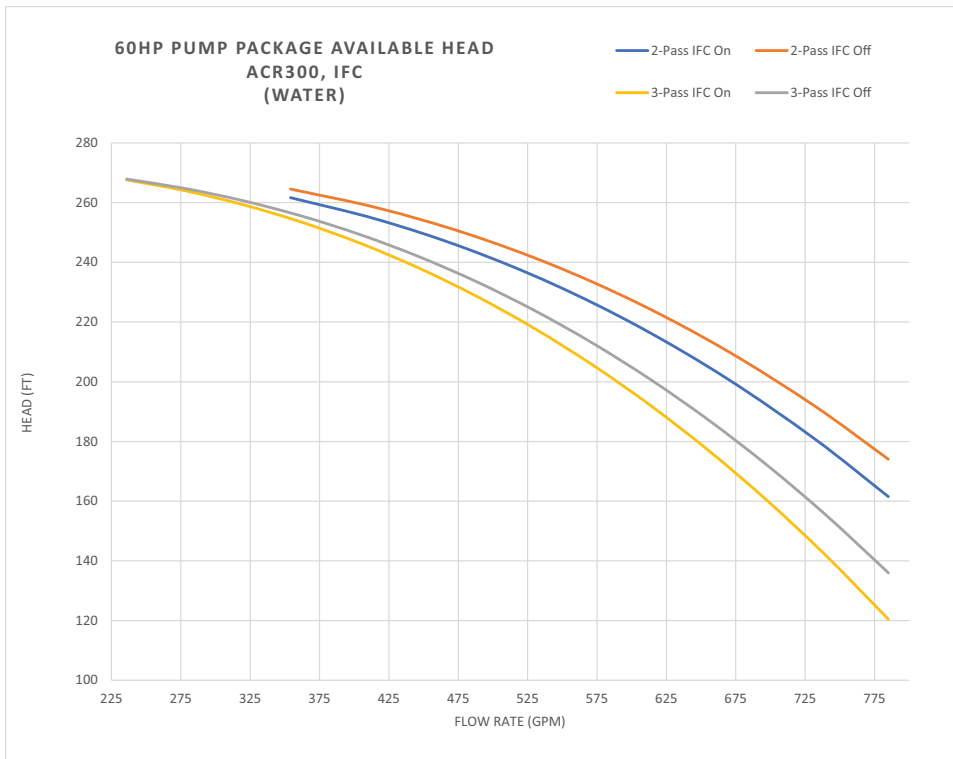

Figure 30. ACR300 – 75hp pump package NPSH_R (water)

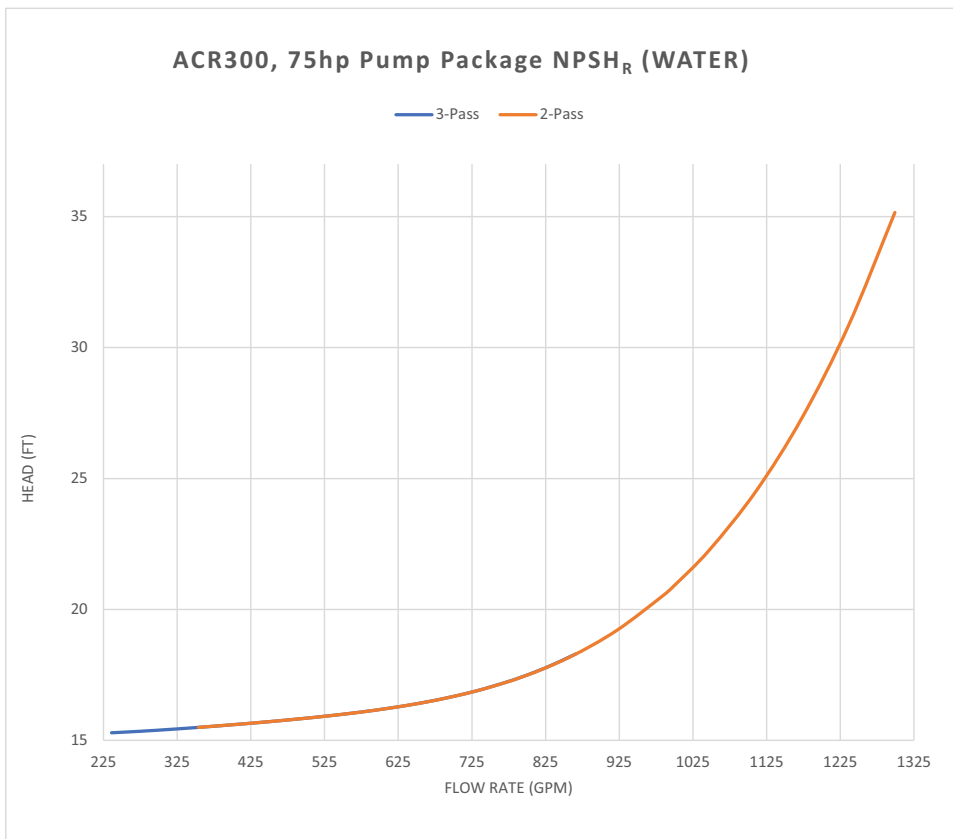

Figure 31. ACR300 – 75hp pump package available head, 8V condenser length

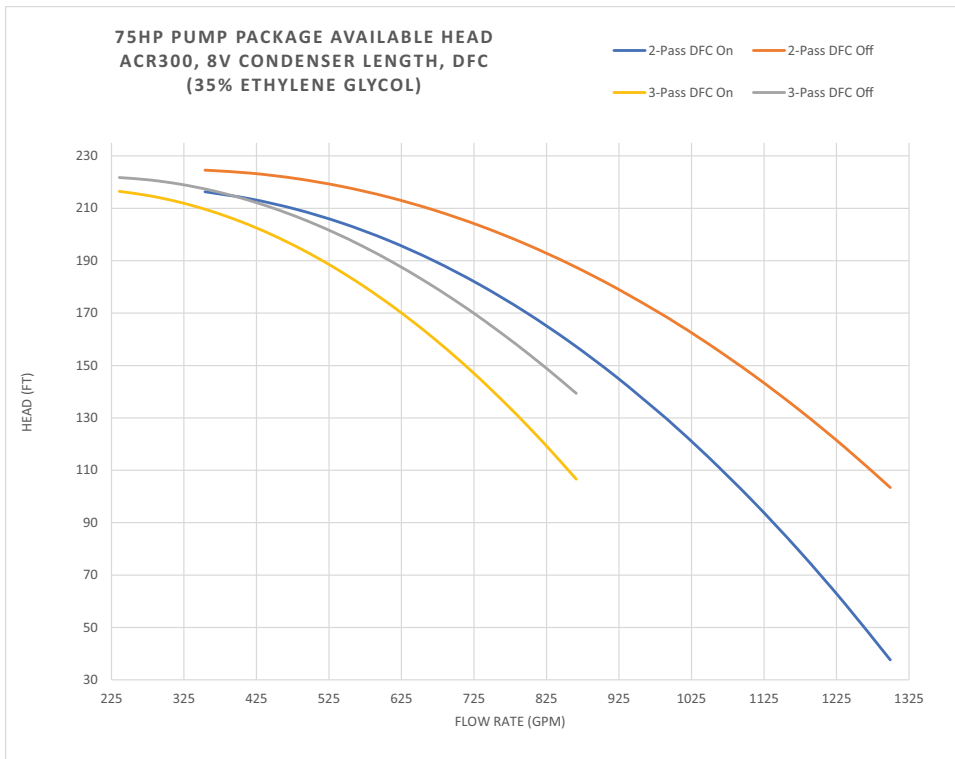

Figure 32. ACR300 – 75hp pump package available head, 10V condenser length

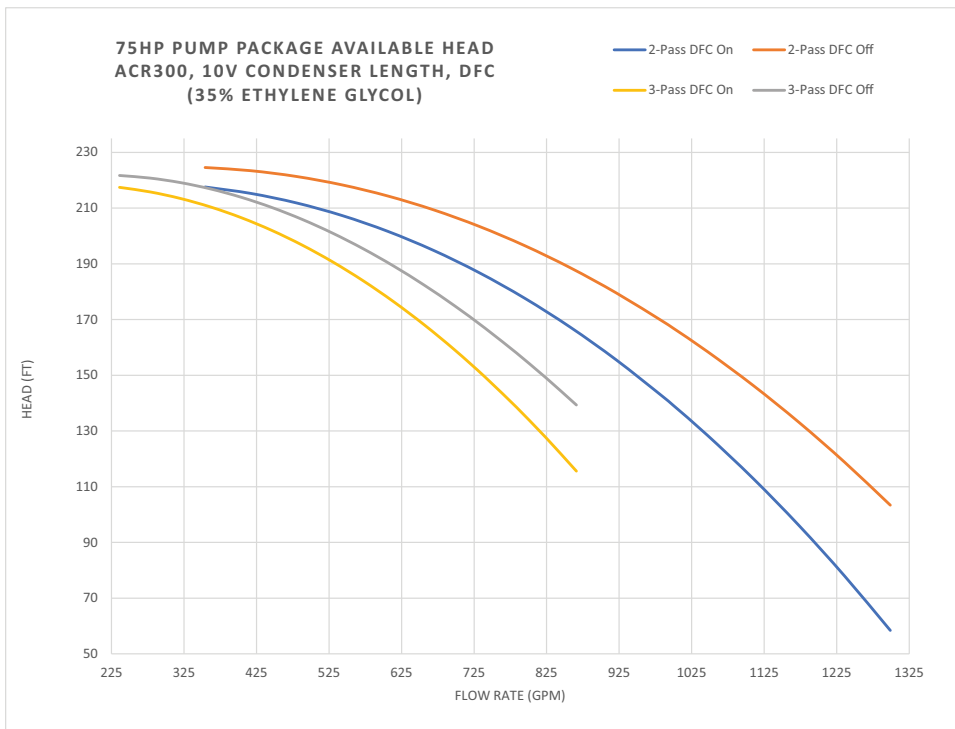
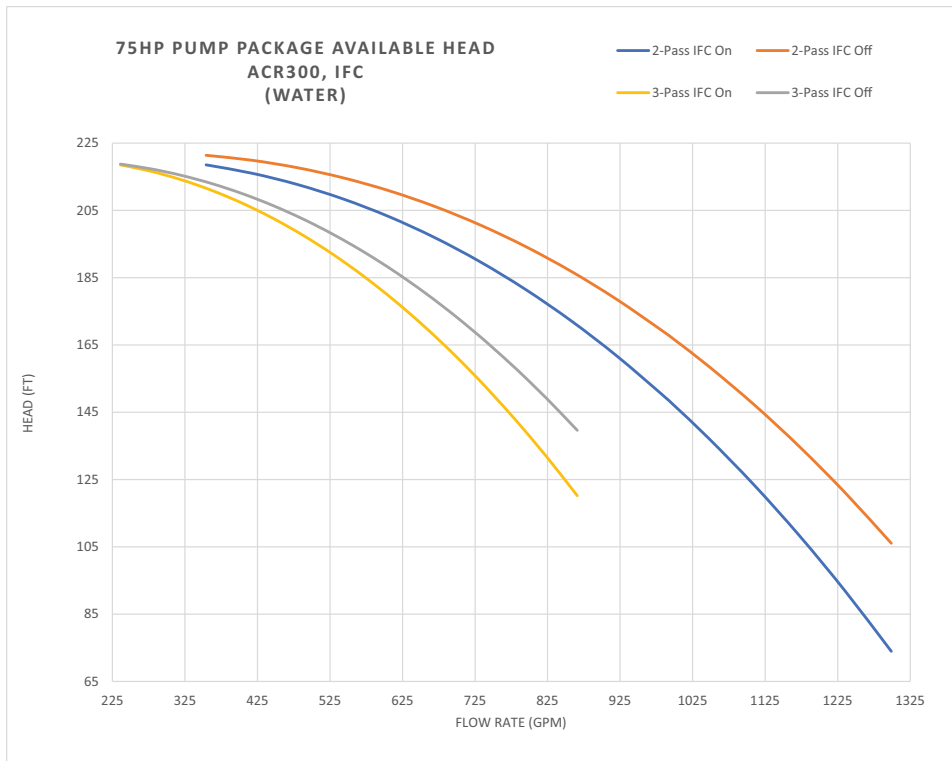

Figure 33. ACR300 – 75hp pump package available head, IFC (water)



Freeze Protection

One or more of the ambient freeze avoidance methods in the table below must be used to protect the chiller from

ambient freeze damage. See *Freeze Avoidance Air-Cooled Chillers Engineering Bulletin* (RF-PRB002*-EN) for more information.



Installation Mechanical

Method	Protects to ambient temperature	Notes
Water Pump Control AND Heaters	Down to -20°F	<ul style="list-style-type: none"> • Heaters alone will provide low ambient protection down to -20°F (-29°C), but will NOT protect the evaporator from freezing as a result of charge migration. Therefore, it is required that water pump control be used in conjunction with heaters. • The optional factory installed pump package includes -20°F (-29°C) ambient freeze protection for water. • Heaters are factory-installed on the evaporator and will protect it from freezing. • Install heat tape on all water piping, pumps, and other components that may be damaged if exposed to freezing temperatures. Heat tape must be designed for low ambient temperature applications. Heat tape selection should be based on the lowest expected ambient temperature. • The controller can start the pump when freezing conditions are detected. For this option the pump must be controlled by the Stealth unit and this function must be validated. • Water circuit valves need to stay open at all times. • Water pump control and heater combination will protect the evaporator down to any ambient temperature provided power is available to the pump and the controller. This option will NOT protect the evaporator in the event of a power failure to the chiller unless backup power is supplied to the necessary components. • When no chiller operation is possible and the pump is already off, controller pump control function for freeze protection will command the pump to turn: <ul style="list-style-type: none"> – ON if average of the evaporator entering water temperature, the evaporator leaving water temperature, and the evaporator refrigerant pool temperature is less than Low Evaporator Refrigerant Temperature Cutout (LERTC) + 4°F for a period of time. – OFF again if the evaporator refrigerant pool temperature rises above the LERTC + 6°F for a period of time. <p><i>Note: Time period referenced for ON and Off conditions above is dependent on past running conditions and present temperatures measured.</i></p> – ON if entering OR leaving water temperature LWTC for 30°F-sec (17°C-sec) – OFF again if water temperature > LWTC for 30 min
Freeze Inhibitor	Varies. See Low Evaporator Refrigerant Cutout, Glycol Requirements.	<ul style="list-style-type: none"> • Freeze protection can be accomplished by adding sufficient glycol to protect against freezing below the lowest ambient expected. • Use of glycol type antifreeze reduces the cooling capacity of the unit and must be considered in the design of the system specifications. • For units with free-cooling option, glycol solution is REQUIRED. See Free-Cooling Fluid Management section.
Drain Water Circuit	Below -20°F	<ul style="list-style-type: none"> • Shut off the power supply to the unit and to all heaters. • Purge the water circuit. • Blow out the evaporator to ensure no liquid is left in the evaporator.

NOTICE

Evaporator Damage!

Failure to follow these instructions could result in damage to the evaporator.

If insufficient concentration or no freeze inhibitor is used, the evaporator water flow must be controlled by the unit controller AND heaters must be used to avoid catastrophic damage to the evaporator due to freezing. It is the responsibility of the installing contractor and/or the customer to ensure that a pump will start when called upon by the chiller controls. Even with water pump control, a power loss of as little as 15 minutes under freezing conditions can damage the evaporator. Only the proper addition of freeze inhibitor or complete drainage of the water circuit can ensure no evaporator damage in the event of a power failure.

Low Evaporator Refrigerant Cutout, Glycol Requirements

The table below shows the low evaporator temperature cutout for different glycol levels. Additional glycol beyond the recommendations will adversely effect unit performance. The unit efficiency will be reduced and the saturated evaporator temperature will be reduced. For some operating conditions this effect can be significant.

additional glycol is used, then use the actual percent glycol to establish the low refrigerant cutout setpoint.

Note: Tables below are not substitutes for full unit simulation for proper prediction of unit performance with specific operating conditions. For information on specific conditions, contact Trane product support.

Table 22. Low evaporator refrigerant temperature cutout (LERTC) and low water temperature cutout (LWTC) — 150 to 330 ton units

Ethylene Glycol				Propylene Glycol			
Glycol Percentage (%)	Solution Freeze Point (°F)	Minimum Recommended LERTC (°F)	Minimum Recommended LWTC (°F)	Glycol Percentage (%)	Solution Freeze Point (°F)	Minimum Recommended LERTC (°F)	Minimum Recommended LWTC (°F)
0	32	28.6	35	0	32	28.6	35
2	31	27.6	34	2	31	27.6	34
4	29.7	26.3	32.7	4	29.9	26.5	32.9
5	29	25.6	32	5	29.3	25.9	32.3
6	28.3	24.9	31.3	6	28.7	25.3	31.7
8	26.9	23.5	29.9	8	27.6	24.2	30.6
10	25.5	22.1	28.5	10	26.4	23	29.4
12	23.9	20.5	26.9	12	25.1	21.7	28.1
14	22.3	18.9	25.3	14	23.8	20.4	26.8
15	21.5	18.1	24.5	15	23.1	19.7	26.1
16	20.6	17.2	23.6	16	22.4	19	25.4
18	18.7	15.3	21.7	18	20.9	17.5	23.9
20	16.8	13.4	19.8	20	19.3	15.9	22.3
22	14.7	11.3	17.7	22	17.6	14.2	20.6
24	12.5	9.1	15.5	24	15.7	12.3	18.7
25	11.4	8	14.4	25	14.8	11.4	17.8
26	10.2	6.8	13.2	26	13.8	10.4	16.8
28	7.7	4.3	10.7	28	11.6	8.2	14.6
30	5.1	1.7	8.1	30	9.3	5.9	12.3
32	2.3	-1.1	5.3	32	6.8	3.4	9.8
34	-0.7	-4.1	5	34	4.1	0.7	7.1
35	-2.3	-5	5	35	2.7	-0.7	5.7
36	-3.9	-5	5	36	1.3	-2.1	5
38	-7.3	-5	5	38	-1.8	-5	5
40	-10.8	-5	5	40	-5.2	-5	5
42	-14.6	-5	5	42	-8.8	-5	5
44	-18.6	-5	5	44	-12.6	-5	5
45	-20.7	-5	5	45	-14.6	-5	5
46	-22.9	-5	5	46	-16.7	-5	5
48	-27.3	-5	5	48	-21.1	-5	5
50	-32.1	-5	5	50	-25.8	-5	5

Table 23. Low evaporator refrigerant temperature cutout (LERTC) and low water temperature cutout (LWTC) — units larger than 330 tons

Ethylene Glycol				Propylene Glycol			
Glycol Percentage (%)	Solution Freeze Point (°F)	Minimum Recommended LERTC (°F)	Minimum Recommended LWTC (°F)	Glycol Percentage (%)	Solution Freeze Point (°F)	Minimum Recommended LERTC (°F)	Minimum Recommended LWTC (°F)
0	32.0	32.0	37.0	0	32.0	32.0	37.0
2	31.0	29.5	36.0	2	31.0	29.5	36.0
4	29.7	28.2	34.7	4	29.9	28.4	34.9



Installation Mechanical

Table 23. Low evaporator refrigerant temperature cutout (LERTC) and low water temperature cutout (LWTC) — units larger than 330 tons (continued)

Ethylene Glycol				Propylene Glycol			
Glycol Percentage (%)	Solution Freeze Point (°F)	Minimum Recommended LERTC (°F)	Minimum Recommended LWTC (°F)	Glycol Percentage (%)	Solution Freeze Point (°F)	Minimum Recommended LERTC (°F)	Minimum Recommended LWTC (°F)
5	29.0	27.5	34.0	5	29.3	27.8	34.3
6	28.3	26.8	33.3	6	28.7	27.2	33.7
8	26.9	25.4	31.9	8	27.6	26.1	32.6
10	25.5	24.0	30.5	10	26.4	24.9	31.4
12	23.9	22.4	28.9	12	25.1	23.6	30.1
14	22.3	20.8	27.3	14	23.8	22.3	28.8
15	21.5	20.0	26.5	15	23.1	21.6	28.1
16	20.6	19.1	25.6	16	22.4	20.9	27.4
18	18.7	17.2	23.7	18	20.9	19.4	25.9
20	16.8	15.3	21.8	20	19.3	17.8	24.3
22	14.7	13.2	19.7	22	17.6	16.1	22.6
24	12.5	11.0	17.5	24	15.7	14.2	20.7
25	11.4	9.9	16.4	25	14.8	13.3	19.8
26	10.2	8.7	15.2	26	13.8	12.3	18.8
28	7.7	6.2	12.7	28	11.6	10.1	16.6
30	5.1	3.6	10.1	30	9.3	7.8	14.3
32	2.3	0.8	7.3	32	6.8	5.3	11.8
34	-0.7	-2.2	5.0	34	4.1	2.6	9.1
35	-2.3	-3.8	5.0	35	2.7	1.2	7.7
36	-3.9	-5.0	5.0	36	1.3	-0.2	6.3
38	-7.3	-5.0	5.0	38	-1.8	-3.3	5.0
40	-10.8	-5.0	5.0	40	-5.2	-5.0	5.0
42	-14.6	-5.0	5.0	42	-8.8	-5.0	5.0
44	-18.6	-5.0	5.0	44	-12.6	-5.0	5.0
45	-20.7	-5.0	5.0	45	-14.6	-5.0	5.0
46	-22.9	-5.0	5.0	46	-16.7	-5.0	5.0
48	-27.3	-5.0	5.0	48	-21.1	-5.0	5.0
50	-32.1	-5.0	5.0	50	-25.8	-5.0	5.0



Installation Electrical

General Recommendations

As you review this manual, keep in mind that:

- All field-installed wiring must conform to National Electric Code (NEC) guidelines, and any applicable state and local codes. Be sure to satisfy proper equipment grounding requirements per NEC.
- Compressor motor and unit electrical data (including motor kW, voltage utilization range, rated load amps) is listed on the chiller nameplate.
- All field-installed wiring must be checked for proper terminations, and for possible shorts or grounds.

Note: Always refer to wiring diagrams shipped with chiller or unit submittal for specific electrical schematic and connection information.

⚠ WARNING

Hazardous Voltage - Pressurized Flammable Fluid!

Failure to follow all electrical safety precautions could result in death or serious injury.

Do not operate compressor without terminal box cover in place.

The motors in the compressors have strong permanent magnet motors and have the capability to generate voltage during situations when the refrigerant charge is being migrated. This potential will be present at the motor terminals and at the output of the variable speed drives in the power panel.

Before removing compressor terminal box cover for servicing, or servicing power side of control panel, **CLOSE COMPRESSOR DISCHARGE SERVICE VALVE** and disconnect all electric power including remote disconnects. Discharge all motor start/run capacitors. Follow lockout/tagout procedures to ensure the power cannot be inadvertently energized. Verify with an appropriate voltmeter that all capacitors have discharged.

The compressor contains hot, pressurized refrigerant. Motor terminals act as a seal against this refrigerant. Care should be taken when servicing NOT to damage or loosen motor terminals.

⚠ WARNING

Hazardous Voltage w/Capacitors!

Failure to disconnect power and discharge capacitors before servicing could result in death or serious injury.

Disconnect all electric power, including remote disconnects and discharge all motor start/run capacitors before servicing. Follow proper lockout/tagout procedures to ensure the power cannot be inadvertently energized. For variable frequency drives or other energy storing components provided by Trane or others, refer to the appropriate manufacturer's literature for allowable waiting periods for discharge of capacitors. Verify with a CAT III or IV voltmeter rated per NFPA 70E that all capacitors have discharged.

⚠ WARNING

Proper Field Wiring and Grounding Required!

Failure to follow code could result in death or serious injury.

All field wiring **MUST** be performed by qualified personnel. Improperly installed and grounded field wiring poses FIRE and ELECTROCUTION hazards. To avoid these hazards, you **MUST** follow requirements for field wiring installation and grounding as described in NEC and your local/state/national electrical codes.

Important: To prevent control malfunctions, do not run low voltage wiring (30 V) in conduit with conductors carrying more than 30 volts.

Units with Nitrogen Charge Option



For units with nitrogen charge option, the unit must NOT have shore power, or unit power applied until the unit has been charged. Applying power will drive EXV valves closed, and will inhibit sufficient Vac for unit charging.

Installer-Supplied Components

Customer wiring interface connections are shown in the electrical schematics and connection diagrams that are shipped with the unit. The installer must provide the following components if not ordered with the unit:

- Power supply wiring (in conduit) for all field-wired connections.



Installation Electrical

- All control (interconnecting) wiring (in conduit) for field supplied devices.
- Fused-disconnect switches or circuit breakers.

Power Supply Wiring

⚠ WARNING

Hazardous Voltage w/Capacitors!

Failure to disconnect power and discharge capacitors before servicing could result in death or serious injury.

Disconnect all electric power, including remote disconnects and discharge all motor start/run capacitors before servicing. Follow proper lockout/tagout procedures to ensure the power cannot be inadvertently energized. For variable frequency drives or other energy storing components provided by Trane or others, refer to the appropriate manufacturer's literature for allowable waiting periods for discharge of capacitors. Verify with a CAT III or IV voltmeter rated per NFPA 70E that all capacitors have discharged.

⚠ WARNING

Proper Field Wiring and Grounding Required!

Failure to follow code could result in death or serious injury.

All field wiring **MUST** be performed by qualified personnel. Improperly installed and grounded field wiring poses **FIRE** and **ELECTROCUTION** hazards. To avoid these hazards, you **MUST** follow requirements for field wiring installation and grounding as described in NEC and your local/state/national electrical codes.

All power supply wiring must be sized and selected accordingly by the project engineer in accordance with NEC Table 310.15(B)(16).

All wiring must comply with local codes and the National Electrical Code. The installing (or electrical) contractor must provide and install the system interconnecting wiring, as well as the power supply wiring. It must be properly sized and equipped with the appropriate overcurrent protection device.

The type and installation location(s) of the overcurrent protection devices must comply with all applicable codes.

Incoming customer power location varies with unit configurations. See figures below.

For 150 to 330 ton units:

- Control Panel
 - Standard length units (model number digits 9 = C, D, E, G, H or 44 = X)
 - Units with optional harmonic filtration (model number digit 44 = L)
- Transformer: 200, 230, 380, 400, or 575 V units with transformer (model number digit 9 = A, B, C, D, or F)

Figure 34. Incoming customer power — control panel (right side view)

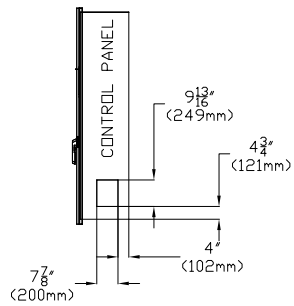
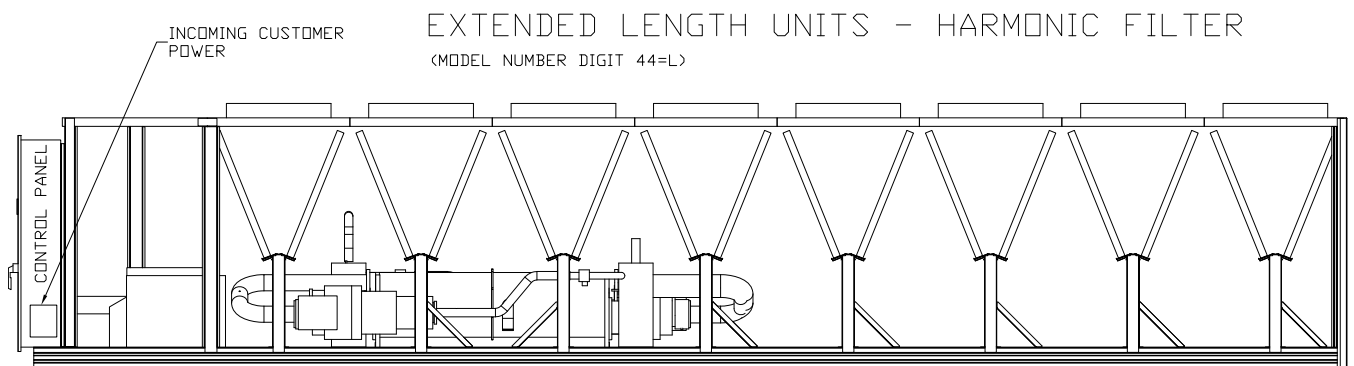
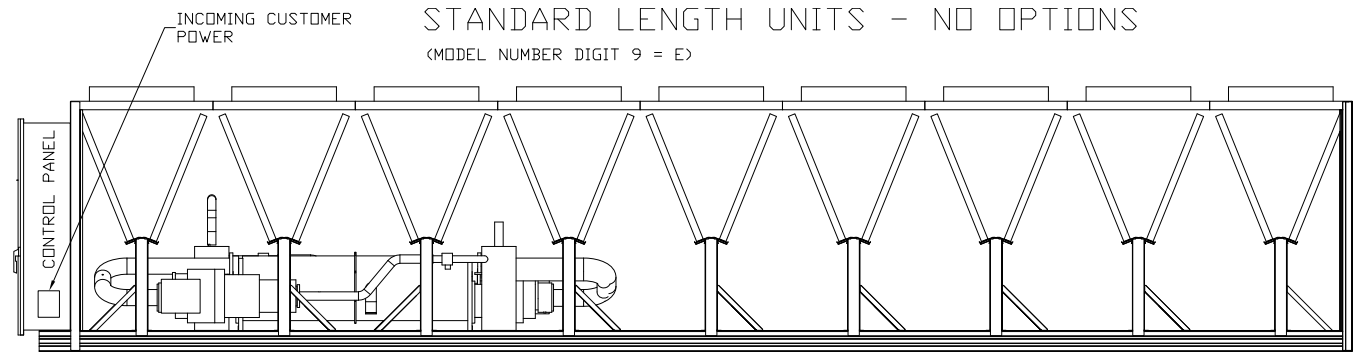
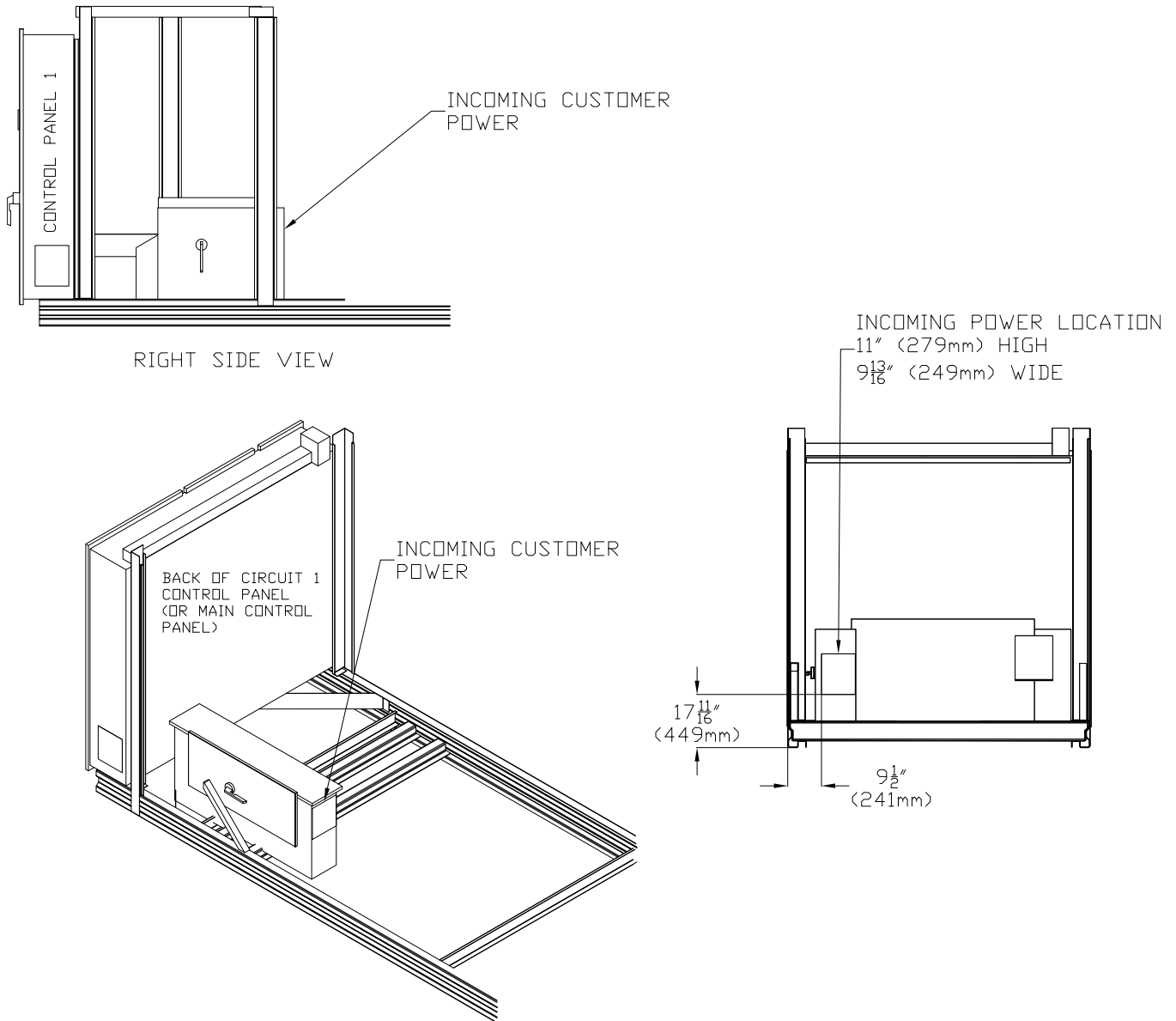

Figure 35. Incoming customer power — transformer

EXTENDED LENGTH UNITS TRANSFORMER

(MODEL NUMBER DIGIT 9 = A,B,C,D,F)

For units larger than 330 tons:

Units with dual power connections will have different spacing between the connections. Units with a single power connection will shift in regards to the unit extents based on tonnage.

- Dual point power (model number digit 29 = 2): 11V units (model number digits 5-7 = 380, 450)
- Single point power (model number digit 29 = 1): 11V units (model number digits 5-7 = 380, 450)

Cut holes into the location indicated for the appropriately-sized power wiring conduits. The wiring is passed through these conduits and connected to the terminal blocks, or circuit breakers.

For 150 to 330 ton units:

- The high voltage field-provided connections are made through patch plate on the right side of the main control panel or on the right side of the voltage autotransformer panel.

- The low voltage connections are made through knockouts provided on the left side of the control panel. Additional grounds may be required for each 115 volt power supply to the unit. Green lugs are provided for 115V customer wiring.

For units larger than 330 tons:

- For dual point power units, the high voltage field-provided connections are made through patch plate on the right side of each control panel. Dimensions of incoming power location on each control panel are as shown in [Figure 34, p. 73](#).
- For single point power units, the high voltage field provided connections are made through the right side or rear of the additional enclosure as noted on the enclosure label. See [Figure 35, p. 74](#).
- The low voltage connections are made through knockouts provided on the left side of the circuit one / main control panel.
- Additional grounds may be required for each 115 volt power supply to the unit. Green terminals are provided for 115V customer wiring.

Adaptive Frequency Drive Capacitor Discharge

⚠ WARNING

Hazardous Voltage w/Capacitors!

Failure to disconnect power and discharge capacitors before servicing could result in death or serious injury.

Disconnect all electric power, including remote disconnects and discharge all motor start/run capacitors before servicing. Follow proper lockout/tagout procedures to ensure the power cannot be inadvertently energized. For variable frequency drives or other energy storing components provided by Trane or others, refer to the appropriate manufacturer's literature for allowable waiting periods for discharge of capacitors. Verify with a CAT III or IV voltmeter rated per NFPA 70E that all capacitors have discharged.

After disconnecting input power, wait twenty minutes for the DC capacitors to discharge before opening the electrical panel. Once the electrical panel is opened, use a non-contact voltage detecting wand to check for any voltage on the input or output terminals of the drive.

Control Power Supply

The unit is equipped with a control power transformer. Additional control power voltage to the unit is not necessary. No other loads should be connected to the control power transformer.

All units are factory-connected for appropriate labeled voltages.

Service Power Connection

The service power connection is a touch-safe procedure for binding the control system and LLIDs. With service power connection, a NEMA 5-15 style extension cord can be used to power Class 2 devices, such as Symbio™ 800, LLIDs, EXVs, and TD-7 display, with an external power source, and without line voltage applied to the unit. For the main enclosure (all unit sizes), connect to 1XJ5. For 375 to 550 ton units, an additional connection is required at 2XJ5. Upstream current protection is required for the extension cord power source. Service power connection required voltage is 115V at 60Hz.

Heater Power Supply

The evaporator shell, indirect free cooling water containing components and factory installed pump packages are insulated and protected from ambient temperatures down to -20°F (-29°C) by thermostatically-controlled immersion heaters. If the freeze protection method of "Water pump control AND heaters" is chosen for a non-free cooling unit, see "[Freeze Protection](#)," p. 67, the installing contractor needs to supply 115V 60Hz single phase circuit to terminals 1X8-1, 2, and 5. These terminals are located behind the low voltage control panel on the inside wall of the main enclosure. See [Figure 36, p. 76](#).

For units with model number digit 29 = 3, this electrical connection is already made by the factory wiring. See [Table 24, p. 76](#) for heater summary.

For evaporators, whenever the water temperature drops to approximately 37°F (2.8°C), the thermostat energizes the heaters.

For the indirect free cooling water containing components and factory installed pump packages, whenever the water temperature drops to approximately 37°F (2.8°C) and there is not a pump command present the thermostat energizes the heaters.

Figure 36. Evaporator heater view

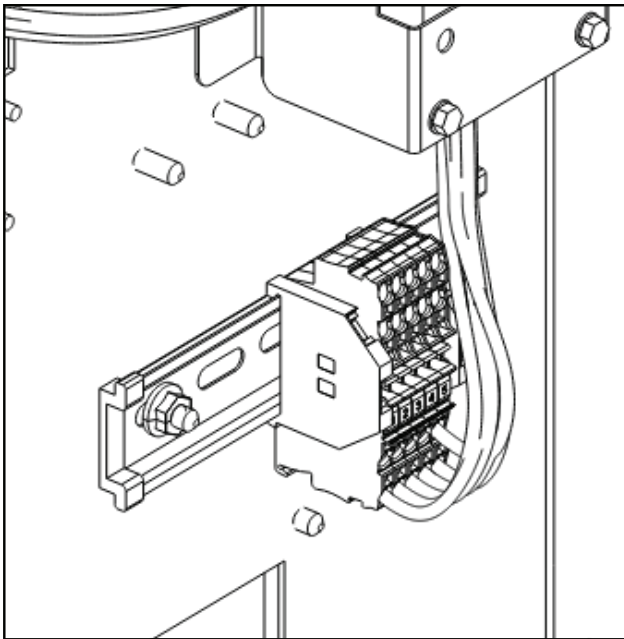

NOTICE

Evaporator Damage!

Failure to follow instructions below could result in evaporator damage.

A qualified technician must confirm operation of the thermostat. Control panel main processor does not verify thermostat operation.

Table 24. Factory installed water heater summary

Unit Size (tons)	Waterboxes	
	Supply	Return
1-pass Evaporator		
Units larger than 300 tons	400W (Qty 2)	400W (Qty 2)
2-pass Evaporator		
150 to 165	400W	400W
180 to 200	400W (Qty 2)	400W
225 to 330	600W	600W
Units larger than 330 tons	400W (Qty 2)	400W (Qty 2)
3-pass Evaporator		
All sizes	400W (Qty 2)	400W
Factory Installed Pump Package ^(a)		
275 to 300	300W (Qty 4)	1200W

^(a) These heaters are in addition to the evaporator waterbox heaters.

Chilled Water Pump Control

NOTICE

Evaporator Damage!

If the microprocessor calls for a pump to start and water does not flow, the evaporator may be damaged catastrophically.

It is the responsibility of the installing contractor and/or the customer to ensure that a pump will always be running when called upon by the chiller controls.

An evaporator water pump output relay's normally-open contact closes to start the evaporator water pump when the chiller is given a signal to go into the Auto mode of operation from any source. The contact is opened to turn off the pump in the event of most machine level diagnostics to prevent the build up of pump heat.

The relay output is required to operate the Evaporator Water Pump (EWP) contactor. The relay's contacts are compatible with 115/240 Vac control circuits. See Programmable Relays section for rating details. Normally, the EWP relay follows the AUTO mode of the chiller. Whenever the chiller has no diagnostics and is in the AUTO mode, regardless of where the auto command is coming from, the relay is energized and the normally-open contact is closed. When the chiller exits the AUTO mode, the relay's normally-open contact is timed to open in an adjustable (using Tracer® TU service tool) 0 to 30 minutes. The non- AUTO modes in which the pump is stopped, include Reset, Stop, External Stop, Remote Display Stop, Stopped by Tracer®, Start Inhibited by Low Ambient Temp, and Ice Building complete.

Table 25. Pump relay operation

Chiller Mode	Relay Operation
Auto	Instant Close
Ice Building	Instant Close
Tracer® Override	Close
Stop	Timed Open
Ice Complete	Instant Open
Diagnostics	Instant Operation ^(a)
Chiller Shutdown Diagnostics (except freeze protection)	Instant Open
Freeze Protection related chiller shutdown diagnostics	Initially: Remain Closed Then: Delayed/Dependent Open
Chiller Off Cycle Freeze Diagnostics	Instant Close – Dependent Open

^(a) Operation can be instant open or instant close, depending on diagnostic.

When going from Stop to Auto, the EWP relay is energized immediately. If evaporator water flow is not established in 20 minutes (for normal transition) or 4 minutes, 15 seconds (for pump commanded ON due to an override safety), the unit controller de-energizes the EWP relay and generates a non-latching diagnostic. If flow returns (e.g. someone else

is controlling the pump), the diagnostic is cleared, the EWP is re-energized, and normal control resumed.

If evaporator water flow is lost once it had been established, the EWP relay remains energized and a non-latching diagnostic is generated. If flow returns, the diagnostic is cleared and the chiller returns to normal operation.

In general, when there is either a non-latching or latching diagnostic, the EWP relay is turned off as though there was a zero time delay. Exceptions whereby the relay continues to be energized occur with:

- **Low Chilled Water Temperature diagnostic** (non-latching unless also accompanied by an Evap Leaving Water Temperature Sensor Diagnostic)

OR

- **Interrupt Failure —AFDxA diagnostic** where x is either 1 or 2 to indicate which drive is affected), in which a compressor continues to draw current even after commanded to have shutdown.

OR

- **Loss of Evaporator Water Flow diagnostic** (non-latching) and the unit is in the AUTO mode, after initially having proven evaporator water flow.

Evaporator Pump Package

When optional evaporator pump package is installed, Evaporator Pump Control is set to Single Pump Variable Speed in Tracer® TU. Additional I/Os are required for Symbio™ 800 to control and monitor the pump VFD. Symbio 800 monitors the pump speed, fault, and running status. Two options selectable in Tracer TU are available for evaporator pump speed control:

- **Direct Pump Speed Control** (factory default): Uses Evap Water Pump Speed setpoint configuration from 0 to 100 percent.
- **Water Flow Control:** Uses Evap Water Flow Rate setpoint configuration from 50 to 1200 gpm.

For each speed control option, speed or water flow setpoints are accessible through the AdaptiView™ Display, Tracer TU, and building automation system.

Note: For the Water Flow Control option, evaporator water flow measurement must be installed.

Evaporator Flow Measurement

Fluid flow through the chiller evaporator is calculated by sensing the pressure drop across its heat exchanger. The heat exchanger pressure drop is determined by measuring the pressure difference between entering and leaving pressures in the evaporator water box. Using this sensed pressure drop, along with coefficients specific to each heat exchanger, the fluid flow rate through the evaporator is computed and displayed at the human interface. Once the flow rate through the evaporator is known, chiller capacity

can be determined. The differential water pressure range is configurable from 0 to 50 psid.

Three configurable water flow measurement types are available (selectable in Tracer® TU):

- Differential Pressure (4-20mA input to Trane LLID)
- Flow Meter (4-20mA input to Trane LLID)
- Dual Pressure Sensors (entering and leaving pressure transducer Trane LLIDs)

Flow calibration points are factory programmed. Contact technical support for flows and pressure drops used for flow calibration if Symbio™ 800 required reprogramming in the field. These setpoints are accessible in Tracer TU.

Programmable Relays

An optional programmable four relay LLID provides hard-wired interlock of certain events or states of the chiller, selected from a list of likely needs, as shown in the field wiring diagram. The relay contacts are single-pole-double-throw (SPDT) and are suitable for use with 120Vac at 7.2A resistive, 2.88A pilot duty, and 1/3 HP (7.2A) or with 240Vac at 5A general purpose duty.

The list of events/states that can be assigned to the programmable relays can be found in the following table. The relay will be energized when the event/state occurs.

Table 26. Alarm and status relay output configurations

Description	
Alarm (Latching)	This output is true whenever there is any active latching shutdown diagnostic that targets the Unit, Circuit, or any of the Compressors on a circuit.
Alarm (Non-Latching)	This output is true whenever there is any active non-latching shutdown diagnostic that targets the Unit, Circuit, or any of the Compressors on a circuit.
Alarm	This output is true whenever there is any active latching or non-latching shutdown diagnostic that targets the Unit, Circuit, or any of the Compressors on a circuit.
Alarm Ckt 1	This output is true whenever there is any active latching or non-latching shutdown diagnostic that targets Circuit 1, or any of the Compressors on Circuit 1.
Alarm Ckt 2	This output is true whenever there is any active latching or non-latching shutdown diagnostic that targets Circuit 2, or any of the Compressors on Circuit 2.
Unit Limit Mode	This output is true whenever a circuit on the unit has been running in one of the limit modes continuously for the Limit Relay debounce time. A given limit or overlapping of different limits must be in effect continuously for the debounce time prior to the output becoming true. It will become false if no limits are present for the debounce time.
Compressor Running	The output is true whenever any compressor is running.
Circuit 1 Running	The output is true whenever any compressor of Circuit 1 is running.



Installation Electrical

Table 26. Alarm and status relay output configurations (continued)

Description	
Circuit 2 Running	The output is true whenever any compressor of Circuit 2 is running.
Maximum Capacity	The output is true whenever the unit has reached maximum capacity continuously for the Max Capacity Relay debounce time. The output is false when the unit is not at maximum capacity continuously for the filter debounce time.
Evaporator Water Freeze Avoidance Request	This relay output is energized any time either the Low Evaporator Water Temperature – Unit Off or the Low Evaporator Temperature Ckt x – Unit Off diagnostics are active. This relay is intended for use as an external interlock for a field engineered and provided solution to mitigate the freeze danger implied by these diagnostics. Generally, this would be used in cases where operation of the evaporator water pump is unacceptable due to the system constraints, (i.e. such as mixing unconditioned warm water with controlled supply water as provided by other parallel chillers. The relay's output can provide the method to close bypass valves so the circulation becomes local to the evap and excludes the load, or can be used to defeat the evap pump override entirely while initiating an independent source of heat / flow to the evap.
Free-Cooling Status	The output is true (closed) whenever Free Cooling is active and the capacity is > 0%. The output is false (open) whenever Free Cooling is inactive or capacity = 0%. Note: Free-cooling option is not available on all sizes.
Free-Cooling Maximum Capacity	The output is true (closed) whenever Free Cooling capacity – 100%. The output is false (open) whenever Free Cooling is 100% capacity. Note: Free-cooling option is not available on all sizes.

Relay Assignments Using Tracer® TU

Tracer®TU Service Tool is used to install the Programmable Relay Option package and assign any of the above list of events or status to each of the four relays provided with the option. (See Tracer® TU section of Controls chapter for more information on this service tool.) The relays to be programmed are referred to by the relay's terminal numbers on the Programmable Unit Status LLID board.

The default assignments for the four available relays of the Programmable Relay option are show in the table below.

Table 27. Default assignments

Relay	Assignment
Relay 1 Terminals J2-1,2,3:	Unit Limit Mode
Relay 2 Terminals J2-4,5,6:	Maximum Capacity

Table 27. Default assignments (continued)

Relay	Assignment
Relay 3 Terminals J2 - 7,8,9:	Compressor Running
Relay 4 Terminals J2 -10,11,12:	Alarm

If any of the Alarm/Status relays are used, provide electrical power, 115 Vac with fused-disconnect to the panel and wire through the appropriate relays (terminals on the LLID board). Provide wiring (switched hot, neutral, and ground connections) to the remote annunciation devices. Do not use power from the chiller's control panel transformer to power these remote devices. See the field wiring diagrams which are shipped with the unit.

Low Voltage Wiring

The remote devices described below require low voltage wiring. All wiring between these remote input devices and the control panel must be made with shielded, twisted pair conductors. Ground the shielding only at the panel.

Important: The remote devices described in this section require low voltage wiring. All wiring between these remote input devices and the control Panel must be made with shielded, twisted pair conductors. Ground the shielding only at the panel.

Emergency Stop

The unit controller provides auxiliary control for a customer-specified or customer-installed latching trip out. When this customer-furnished remote contact is provided, the chiller will run normally when the contact is closed. When the contact opens, the unit will trip on a latching diagnostic. This latched condition requires either a manual reset at the front of the control panel or a power cycle of the unit controller to clear.

Connect low voltage leads to Emergency Stop terminal strip locations on External Auto-Stop and Emergency Stop Inputs LLID board. Refer to the field diagrams that are shipped with the unit.

Silver or gold-plated contacts are recommended. These customer-furnished contacts must be compatible with 24 Vdc, 12 mA resistive load.

External Auto/Stop

If the unit requires the external Auto/Stop function, the installer must provide leads from the remote contacts to the External Auto-Stop terminals of the External Auto-Stop and Emergency Stop Inputs LLID board in on the control panel.

The chiller will run normally when the contacts are closed. When either contact opens, the compressor(s), if operating, will go to the RUN:UNLOAD operating mode and cycle off. Unit operation will be inhibited. Closure of the contacts will permit the unit to return to normal operation.

Field-supplied contacts for all low voltage connections must be compatible with dry circuit 24 Vdc for a 12 mA resistive load. Refer to the field diagrams that are shipped with the unit.

External Circuit Lockout – Circuit #1 and #2

The unit controller provides for an auxiliary input of a customer specified or installed contact closure, for individual inhibition of the operation of either or both circuits. If the contact is closed, the respective refrigerant circuit will not operate.

Upon contact opening, the respective refrigerant circuit will run normally. This feature is used to restrict total chiller operation, e.g. during emergency generator operations.

Connections to External Circuit Lockout Inputs LLID inputs are shown in the field diagrams that are shipped with the unit.

These customer-supplied contact closures must be compatible with 24 Vdc, 12 mA resistive load. Silver or gold plated contacts are recommended

Ice Building Option

The unit controller provides auxiliary control for a customer-specified or customer-installed contact closure for ice building if configured and enabled. This output is known as the Ice Building Status Relay. The normally open contact will be closed when ice building is in progress and open when ice building has been normally terminated either through Ice Termination setpoint being reached or removal of the Ice Building command. This output is for use with the ice storage system equipment or controls (provided by others) to signal the system changes required as the chiller mode changes from **ice building** to **ice complete**. When Ice Making Control contact is provided, the chiller runs normally when the contact is open.

The unit controller accepts either an isolated contact closure (External Ice Building command) or a Remote Communicated input (Tracer®) to initiate and command the Ice Building mode.

The unit controller also provides a **Front Panel Ice Termination Setpoint**, settable through Tracer® TU, and adjustable from 20 to 31°F (-6.7 to -0.5°C) in at least 1°F (1°C) increments.

Note: *When in the ice building mode, and the evaporator entering water temperature drops below the ice termination setpoint, the chiller terminates the ice building mode and changes to the ice building complete mode.*

NOTICE

Equipment Damage!
Failure to follow instructions could result in damage to system components.
Freeze inhibitor must be adequate for the leaving water temperature.

Tracer® TU must also be used to enable or disable Ice Machine Control. This setting does not prevent the Tracer® from commanding Ice Building mode.

On contact closure, the unit controller will initiate an ice building mode, in which the unit runs fully loaded at all times. Ice building is terminated either by opening the contact or based on the entering evaporator water temperature. The unit controller does not permit the ice building mode to be reentered until the unit has been switched out of ice building mode (open Ice Making Control contacts) and then switched back into ice building mode (close Ice Making Control contacts.)

In ice building, all limits (freeze avoidance, evaporator, condenser, current) will be ignored. All safeties will be enforced.

If, while in ice building mode, the unit gets down to the freeze state setting (water or refrigerant), the unit will shut down on a manually resettable diagnostic, just as in normal operation.

Connect leads from customer supplied 7S6 to J2-3/4 on 1KF34. Refer to the field diagrams which are shipped with the unit.

Silver or gold-plated contacts are recommended. These customer-furnished contacts must be compatible with 24 Vdc, 12 mA resistive load.

External Chilled Water Setpoint (ECWS) Option

The unit controller provides inputs that accept either 4-20 mA or 2-10 Vdc signals to set the external chilled water setpoint (ECWS). This is not a reset function. The input defines the setpoint. This input is primarily used with generic building automation systems (BAS). The chilled water setpoint set via the Tracer® AdaptiView™ TD-7 or through digital communication. The arbitration of the various chilled water setpoint sources is described in the flow charts at the end of the section.

The chilled water setpoint may be changed from a remote location by sending either a 2-10 Vdc or 4-20 mA signal to the External Demand Limit and Chilled Water Setpoint Inputs LLID board, terminals 5 and 6 LLID. 2-10 Vdc and 4-20 mA each correspond to a 10 to 65°F (-12 to 18°C) external chilled water setpoint.

The following equations apply:

Voltage Signal	
As generated from external source	$Vdc=0.1455*(ECWS) + 0.5454$
As processed by controller	$ECWS=6.875*(Vdc) - 3.75$
Current Signal	
As generated from external source	$mA=0.2909*(ECWS) + 1.0909$
As processed by controller	$ECWS=3.4375(mA) - 3.75$

If the ECWS input develops an open or short, the LLID will report either a very high or very low value back to the main processor. This will generate an informational diagnostic and the unit will default to using the front Panel (TD-7) Chilled Water Setpoint.

Tracer® TU Service Tool is used to set the input signal type from the factory default of 2-10 Vdc to that of 4-20 mA. Tracer® TU is also used to install or remove the External Chilled Water Setpoint option as well as a means to enable and disable ECWS.

External Demand Limit Setpoint (EDLS) Option

Similar to the above, the controller also provides an optional External Demand Limit Setpoint (EDLS) that will accept either a 2 to 10 Vdc (default) or a 4 to 20 mA signal. The demand limit can also be set via the operator display or through digital communication with Tracer® SC+ building automation system or third party building automation system. The arbitration of the various sources of demand limit is described in the flow charts at the end of this section. The EDLS may be changed from a remote location by hooking up the analog input signal to the board 1A7, J2-2 and 3. Refer to the following paragraph on Analog Input Signal Wiring Details. The following equations apply for EDLS if using default minimum 40 percent and maximum 120 percent.

Voltage Signal	
As generated from external source	Vdc=0.1 (%) -2.0
As processed by the unit controller	%=10*(Vdc)+20
Current Signal	
As generated from external source	mA=0.2 (%) -4.0
As processed by the unit controller	%=5*(mA)+20

If the EDLS input develops an open or short, the LLID will report either a very high or very low value back to the main processor. This will generate an informational diagnostic and the unit will default to using the Front Panel Demand Limit Setpoint.

Tracer® TU must be used to set the input signal type from the factory default of 2 to 10 Vdc to that of 4 to 20 mA current. Tracer TU must be also be used to install or remove the External Demand Limit Setpoint Option for field installation, or can be used to enable or disable the feature (if installed).

EDLS and ECWS Analog Input Signal Wiring Details:

Both the ECWS and EDLS can be connected and setup as either a 2 to 10 Vdc (factory default), 4 to 20 mA, or resistance input (also a form of 4 to 20mA) as indicated below. Depending on the type to be used, Tracer TU must be used to configure the LLID and the controller for the

proper input type that is being used. This is accomplished by a setting change on the Custom Tab of the Configuration View within Tracer TU.

The J2-3 and J2-6 terminal is chassis grounded and terminal J2-1 and J2-4 can be used to source 12 Vdc. The EDLS uses terminals J2-2 and J2-3. ECWS uses terminals J2-5 and J2-6. Both inputs are only compatible with high-side current sources.

Figure 37. Wiring examples for EDLS and ECWS/EHWS

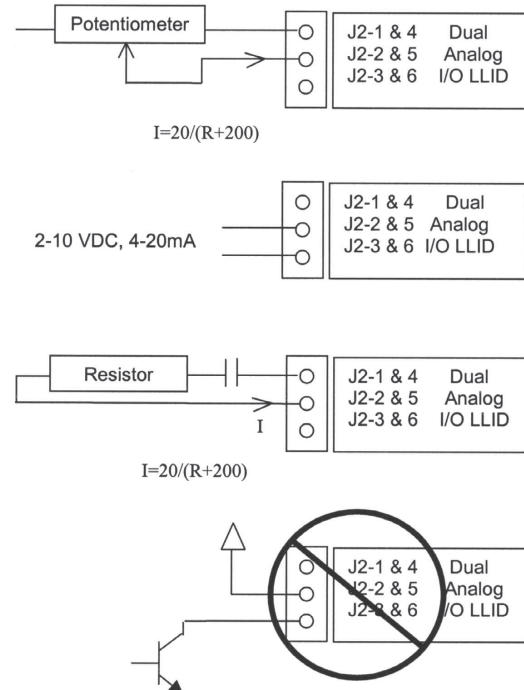

EDLS and ECWS Analog Input Signal Wiring

Both the ECWS and EDLS can be connected and setup as either a 2–10 Vdc (factory default), 4–20 mA, or resistance input (also a form of 4–20mA) as indicated below. Depending on the type to be used, the Tracer® TU Service Tool must be used to configure the LLID and the main processor for the proper input type that is being used. This is accomplished by a setting change on the Custom Tab of the Configuration View within Tracer® TU.

Important: For proper unit operation, BOTH the EDLS and ECWS settings MUST be the same (2-10 Vdc or 4-20mA), even if only one input is to be used.

The J2–3 and J2–6 terminal is chassis grounded and terminal J2–1 and J2–4 can be used to source 12 Vdc. The EDLS uses terminals J2–2 and J2–3. ECWS uses terminals J2–5 and J2–6. Both inputs are only compatible with highside current sources.

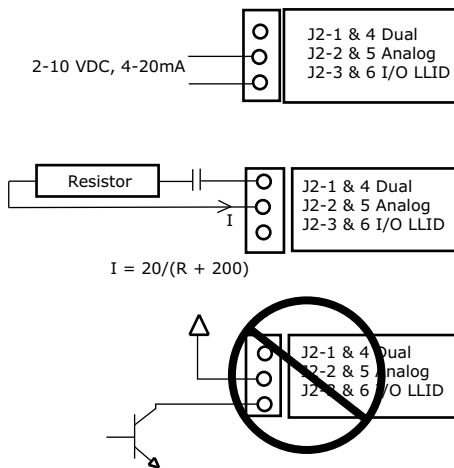
Figure 38. Wiring examples for EDLS and ECWS

Chilled Water Reset (CWR)

The unit controller resets the chilled water temperature set point based on either return water temperature, or outdoor air temperature. Return Reset is standard, Outdoor Reset is optional.

The following shall be selectable:

- One of three Reset types: None, Return Water Temperature Reset, Outdoor Air Temperature Reset, or Constant Return Water Temperature Reset.
- Reset Ratio setpoints: For outdoor air temperature reset there shall be both positive and negative reset ratios.
- Start Reset Setpoints.
- Maximum Reset setpoints.

The equations for each type of reset are as follows:

Return

$$CWS' = CWS + \text{RATIO} (\text{START RESET} - (TWE - TWL))$$

and $CWS' > \text{or} = CWS$

and $CWS' - CWS < \text{or} = \text{Maximum Reset}$

Outdoor

$$CWS' = CWS + \text{RATIO} * (\text{START RESET} - \text{TOD})$$

and $CWS' > \text{or} = CWS$

and $CWS' - CWS < \text{or} = \text{Maximum Reset}$

where

- CWS' is the new chilled water set point or the **reset CWS**
- CWS is the active chilled water set point before any reset has occurred, e.g. normally Front Panel, Tracer[®], or ECWS
- RESET RATIO is a user adjustable gain
- START RESET is a user adjustable reference
- TOD is the outdoor temperature
- TWE is entering evap. water temperature

- TWL is leaving evap. water temperature
- MAXIMUM RESET is a user adjustable limit providing the maximum amount of reset. For all types of reset, $CWS' - CWS < \text{or} = \text{Maximum Reset}$.

Reset Type	Range Reset Ratio	Start Reset	Max Reset	Increment	Factory Default
Return	10 to 120%	4 to 30°F (2.2 to 16.7 °C)	0 to 20°F (0.0 to 11.1°C)	1%	50%
Outdoor	-80 to 80%	50 to 130°F (10 to 54.4°C)	0 to 20°F (0.0 to 11.1°C)	1%	10%

In addition to Return and Outdoor Reset, the MP provides a menu item for the operator to select a Constant Return Reset. Constant Return Reset will reset the leaving water temperature set point so as to provide a constant entering water temperature. The Constant Return Reset equation is the same as the Return Reset equation except on selection of Constant Return Reset, the MP will automatically set Ratio, Start Reset, and Maximum Reset to the following:

- RATIO = 100%
- START RESET = Design Delta Temp.
- MAXIMUM RESET = Design Delta Temp.

The equation for Constant Return is then as follows:

$$CWS' = CWS + 100\% (\text{Design Delta Temp.} - (TWE - TWL)) \text{ and } CWS' > \text{or} = CWS$$

- and $CWS' - CWS < \text{or} = \text{Maximum Reset}$

When any type of CWR is enabled, the MP will step the Active CWS toward the desired CWS' (based on the above equations and setup parameters) at a rate of 1 degree F every 5 minutes until the Active CWS equals the desired CWS'. This applies when the chiller is running.

When the chiller is not running, CWS is reset immediately (within one minute) for Return Reset and at a rate of 1 degree F every 5 minutes for Outdoor Reset. The chiller will start at the Differential to Start value above a fully reset CWS or CWS' for both Return and Outdoor Reset.

Building Automation Systems

BACnet[®] Building Automation Control Network

The BACnet control network for Symbio[™] 800 expands communications from the unit controls network to the Tracer[®] Ensemble[™] or Tracer[®] SC+ building automation system (BAS) or third party building automation system. Utilizing BACnet, the BAS allows external setpoint and configuration adjustment and monitoring of status and diagnostics. The Symbio 800 utilizes the BACnet defined TP protocol as defined in ASHRAE standard 135-2004. This controller works in standalone mode, with Tracer



Installation Electrical

Ensemble, Tracer SC+ or when connected to a third party building automation system that supports BACnet.

Modbus® Automation Control Network

Allows the user to easily interface with Modbus RTU communication protocol via a single twisted pair wiring or Modbus TCP over Ethernet from the Symbio™ 800 controller to a factory installed device.

LonTalk® Building Automation Systems

The LonTalk communication protocol for the Symbio™ 800 controller expands communications from the unit controls network to a Tracer® Ensemble™ building automation system or third party building automation system. Utilizing LonTalk, the BAS allows external setpoint and configuration adjustment and monitoring of status and diagnostics. The Symbio 800 utilizes an FTT-10A free topology transceiver, which supports non-polarity sensitive, free topology wiring—which in turn allows the system installer to utilize star, bus, and loop architectures. This controller works in standalone mode, peer-to-peer with one or more other units, or when connected to a Tracer Ensemble, Tracer SC+, or a third party building automation system that supports LonTalk.

Note: *An optional module is required for Symbio 800 support of LonTalk. See Tracer® USB LonTalk Module Installation Instructions (BAS-SVN138*-EN).*



Operating Principles

This section describes the overall operating principles of the Ascend™ ACR chiller with Symbio™ controls.

Refrigeration Circuits

Each unit has two refrigerant circuits, with a minimum of one rotary screw compressor per circuit. Each refrigerant circuit includes compressor suction and discharge service valves, liquid line shutoff valve, removable core filter, liquid line sight glass with moisture indicator, charging port and an electronic expansion valve. Fully modulating compressors and electronic expansion valves provide variable capacity modulation over the entire operating range. Lower condensing temperatures and higher suction temperatures along with more efficient compressors and fans result in the premium efficiency level.

Refrigeration Cycle

The refrigeration cycle of the chiller is represented in the pressure enthalpy diagram shown in figure below. Key state points are indicated on the figure. The cycle for the full load AHRI design point is represented in the plot.

Figure 39. Pressure-enthalpy (P-h) diagram

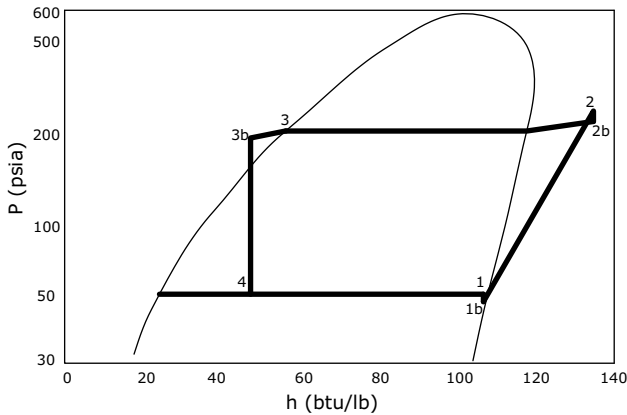

The chiller uses a shell and tube evaporator design with refrigerant evaporating on the shell side and water flowing inside tubes having enhanced surfaces (states 4 to 1). The suction lines are designed to minimize pressure drop. (states 1 to 1b). The compressor is a twin-rotor helical rotary compressor designed similarly to the compressors offered in other Trane Screw Compressor Based Chillers (states 1b to 2). The discharge lines include a highly efficient oil separation system that removes 99.8% of the oil from the refrigerant stream going to the heat exchangers (states 2 to 2b). De-superheating, condensing and sub-cooling is accomplished in a fin and tube or microchannel air cooled heat exchanger where refrigerant is condensed in the tube (states 2b to 3b). Refrigerant flow through the system is balanced by an electronic expansion valve (states 3b to 4).

Refrigerant

The Ascend™ ACR chiller uses environmentally friendly R-513A. Trane believes responsible refrigerant practices are important to the environment, our customers, and the air conditioning industry. All technicians who handle refrigerants must be certified. The Federal Clean Air Act (Section 608) sets forth the requirements for handling, reclaiming, recovering and recycling of certain refrigerants and the equipment that is used in these service procedures. In addition, some states or municipalities may have additional requirements that must also be adhered to for responsible management of refrigerants. Know the applicable laws and follow them.

Refrigerant R-513A is a medium pressure refrigerant. It may not be used in any condition that would cause the chiller to operate in a vacuum without a purge system. Ascend™ ACR is not equipped with a purge system. Therefore, the chiller may not be operated in a condition that would result in a saturated condition in the chiller of -20°F (-29°C) or lower.

Refrigerant R-513A requires the use of specific POE oils as designated on the unit nameplate.

Important: Use only R-513A refrigerant and Trane OIL0075E / OIL00386 (5 gallon).

Compressor and Oil System

Each rotary screw compressor is semi-hermetic, direct drive with capacity control via a variable speed drive, rolling element bearings, differential refrigerant pressure oil pump and oil heater. To maximize efficiency, the variable Vi (variable pressure ratio) compressor is controlled to one of two possible states depending on the chiller system operating point and to provide ease of starting. The motor is a suction gas cooled, hermetically sealed, permanent magnet motor. An oil separator is provided separately from the compressor. Oil filtration is provided internal to the compressor. Check valves in the compressor discharge and lube oil system are also provided.

Condenser and Fans

Air-cooled microchannel condenser coils use all Long Life Alloy aluminum brazed fin construction. The condenser will have an integral subcooling circuit. The maximum allowable working pressure of the condenser is 350 psig (2412 kPa).

The condenser coil has an integral subcooling circuit. Condensers are factory proof tested and leak tested.

Condenser fans are direct-drive vertical discharge. The condenser fan motors are permanent magnet motors with integrated drive to provide variable speed fan control for all fans. Fans are designed with permanently lubricated ball bearings, internal temperature and current overload protection, and customer fault feedback as a standard



Operating Principles

product offering. The fan impeller is a bladed-shrouded fan made from heavy-duty molded plastic.

Standard units will start and operate between 32 to 105°F (0 to 40°C) ambient.

The unit controller calculates optimum fan speed for maximum efficiency based on compressor load and outdoor air, resulting in high IPLV values

Evaporator

Evaporators are configured as follows:

- Tube-in-shell heat exchanger design, constructed from carbon steel shells and tubesheets.
- Internally and externally finned seamless copper tubes are mechanically expanded into the tube sheets.
- Designed, tested, and marked in accordance with the ASME Boiler and Pressure Vessel Code for a refrigerant side working pressure of 200 psig.
- Water side working pressure 150 psig.
- Water connection design:
 - Standard: Grooved for Victaulic style pipe couplings.
 - Optional: Flange style connections.

- Waterboxes include vent, drain, and fittings for temperature control sensors. Available pass configurations:
 - 150 to 330 ton units: 2 or 3-pass
 - Units larger than 330 tons: 1 or 2-pass
- Insulated (3/4 inch closed cell).
- Evaporator water heaters with thermostat are provided to protect the evaporator from freezing at ambient temperatures down to -20°F (-29°C).
- Factory installed flow switch is installed on the supply water box in the evaporator inlet connection.

Free-Cooling Operating Modes

The advantage of optional chiller integrated free-cooling is the ability to utilize outdoor air temperatures to assist in making chilled water when appropriate. The unit controls direct flow through or around the free-cooling coils to optimize chiller efficiency. Determining the operating mode depends on four temperatures:

- Ambient air temperature
- Evaporator entering fluid temperature
- Evaporator leaving fluid temperature
- Chilled water setpoint

Table 28. Free-cooling operation

Component	Mechanical Cooling	Combined Mechanical and Free-Cooling	Free-Cooling Only	
			Fan Control	Valve Control
Ambient Air	Greater than Fluid	Less than Fluid	Less than Fluid	Less than Fluid
Compressors	On — Modulating	On — Modulating	Off	Off
Fans	On — Modulating	On — Modulating	Modulating	15%
Free-Cooling Coil Flow	Off	100%	100%	Modulating

Mechanical Cooling Mode

In this operating mode, ambient temperature is the same or higher than the temperature of the fluid entering the evaporator. Free-cooling coils are bypassed, compressors are running, and the controls modulate compressors and fans to meet cooling load at optimum efficiency.

Combined Mechanical and Free-Cooling Mode

If the ambient temperature is below the evaporator entering fluid temperature, and free-cooling only cannot satisfy the load, the controls modulate compressors and fans to meet the remaining cooling load at optimum efficiency. Fluid will continue to flow through free-cooling coils, reducing the evaporator entering fluid temperature.

Note: Depending on load, one or both circuits may engage mechanical cooling.

Free-Cooling Only Mode

In this operating mode, free-cooling is enabled and capable of meeting the cooling load without the need for mechanical cooling. As ambient falls below the temperature at which full load capacity is provided by free cooling only (or as the load drops), capacity control is accomplished by fan control and control valve modulation. If ambient (or load) continues to drop, valve control provides modulation between free-cooling coils.



Controls Overview

Ascend™ chillers utilize the following control/interface components:

- Symbio™ 800 Controller
- Tracer® AdaptiView™ TD-7 Operator Interface

Symbio™ 800

The Symbio 800 controller is a factory-installed, application specific and programmable controller designed to control chillers and large packaged HVAC equipment. A 7-inch user interface features a touch-sensitive color screen that provides facility managers at-a-glance operating status, performance monitoring, scheduling changes, and operating adjustments. Other advanced features include automated controller back-up, and optional features such as secure remote connectivity, wireless building communications, mobile device connectivity, and custom programming with an expandable I/O.

For more information, see *Symbio™ 800 Controller Installation, Operation, and Maintenance* (BAS-SVX080*-EN).

AdaptiView™ Display

Information is tailored to operators, service technicians, and owners. When operating a chiller, specific information is needed on a day-to-day basis—setpoints, limits, diagnostic information, and reports. This information is provided through the AdaptiView™ display. Logically organized groups of information— chiller modes of operation, active diagnostics, settings and reports put information conveniently at your fingertips.

For more information, see *AdaptiView™ Display with Symbio™ Controls Ascend™ Air-Cooled Chiller Model ACR Series C User Guide* (AC-SVU003*-EN).

Noise Reduction Mode

When InvisiSound™ Standard with Noise Reduction, InvisiSound Superior with Noise Reduction or InvisiSound Ultimate option is selected, noise reduction mode can be enabled to adjust fan speed and lower maximum sound levels. Maximum fan speed is configurable from 600 to 1000 rpm (950 rpm factory default). When noise reduction is enabled, an additional fan speed clamp setpoint from 70 to 100 percent of maximum fan speed (80 percent factory default) is available. The noise reduction feature is accessible through the operator display, external input, or building automation system. When accessing at Tracer® AdaptiView™ display, access is found on the Settings screen.

- Set the Front Panel Noise Reduction Request to ON.
- Adjust the Noise Reduction Condenser Fan Speed Clamp to desired value.

Tracer® TU

The AdaptiView TD-7 operator interface allows for daily operational tasks and setpoint changes. However, to adequately service chillers, Tracer® TU service tool is required. (Non-Trane personnel, contact your local Trane office for software purchase information.) Tracer TU adds a level of sophistication that improves service technician effectiveness and minimizes chiller downtime. This portable PC-based service-tool software supports service and maintenance tasks, and is required for software upgrades, configuration changes and major service tasks.

Tracer TU serves as a common interface to all Trane chillers, and will customize itself based on the properties of the chiller with which it is communicating. Thus, the service technician learns only one service interface.

The panel bus is easy to troubleshoot using LED sensor verification. Only the defective device is replaced. Tracer TU can communicate with individual devices or groups of devices.

All chiller status, machine configuration settings, customizable limits, and up to 100 active or historic diagnostics are displayed through the service-tool software interface.

LEDs and their respective Tracer TU indicators visually confirm the availability of each connected sensor, relay, and actuator.

Tracer TU is designed to run on a customer's laptop, connected to the Symbio™ 800 control panel with a USB cable. See *Tracer® TU Service Tool User Guide* (BAS-SVU046*-EN) for laptop requirements.

Notes:

- *Tracer TU is designed and validated for this minimum laptop configuration. Any variation from this configuration may have different results. Therefore, support for Tracer TU is limited to only those laptops with the configuration previously specified.*
- *For more information, see Tracer® TU Service Tool User Guide (BAS-SVU046*-EN).*

Figure 40. Tracer TU

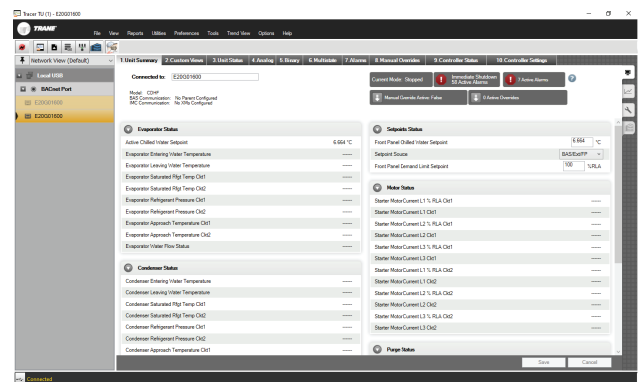



Integrated Rapid Restart

Chiller controls are designed and engineered for Rapid Restart™. In the event of a power interruption, the chiller will start a compressor before the front panel display is fully powered up, eliminating the need for an uninterrupted power supply (UPS). Advanced features and functionality are built into the chillers. Bringing a chiller back online rapidly after a loss of power is critical to operations in mission critical environments, which demand the highest levels of reliability.

Under optimal conditions, it can restart in as little as 45 seconds with no need for uninterrupted power supply (UPS). An 80 percent cooling load can be achieved in less than 2.5 minutes after power restoration.



Pre-Start

Upon completion of installation, complete the Installation Completion Check Sheet and Request for Trane Service checklist in .

Important: *Start-up must be performed by Trane or an agent of Trane specifically authorized to perform start-up and warranty of Trane products. Contractor shall provide Trane (or an agent of Trane specifically authorized to perform start-up) with notice of the scheduled start-up at least two weeks prior to the scheduled start-up.*



Start-Up and Shutdown

Important: Initial unit commissioning start-up must be performed by Trane or an agent of Trane specifically authorized to perform start-up and warranty of Trane products. Contractor shall provide Trane (or an agent of Trane specifically authorized to perform start-up) with notice of the scheduled start-up at least two weeks prior to the scheduled start-up.

Unit Start-Up

NOTICE

Equipment Damage!

Failure to follow instructions could result in equipment damage.

Ensure that the compressor and oil sump heaters have been operating properly for a minimum of 24 hours before starting.

NOTICE

Equipment Damage!

Snow, ice, or debris build up on fans could cause excessive imbalance and equipment damage.

Clear fans of build up prior to machine start-up.

If the water flow is lower than Min. flow Cooling in the General Data / for water coolant, set Heating Low Ambient Lockout Temperature to 32°F in TD-7. If required, once the system has been operating for approximately 30 minutes and has become stabilized, complete the remaining start-up procedures, as follows:

1. Check the evaporator refrigerant pressure and the condenser refrigerant pressure under Reports on the AdaptiView™ TD-7 or Tracer® TU. The pressures are referenced to sea level (14.6960 psia).
2. Check the EXV sight glasses after sufficient time has elapsed to stabilize the chiller. The refrigerant flow past the sight glasses should be clear. Bubbles in the refrigerant indicate either low refrigerant charge or excessive pressure drop in the liquid line or a stuck open expansion valve. A restriction in the line can sometimes be identified by a noticeable temperature differential between the two sides of the restriction. Frost will often form on the line at this point. Proper refrigerant charges are shown in the General Information Section.

Important: A clear sight glass alone does not mean that the system is properly charged. Also check system subcooling, liquid level control and unit operating pressures.

If chiller is limited by any limiting conditions, contact local Trane service organization for more information.

Temporary Shutdown and Restart

To shut the unit down for a short time:

- Press the STOP key on the AdaptiView™ TD-7. The compressors will continue to operate and an operational pump down cycle may be initiated.
- Symbio™ 800 pump control will turn off the pump (after a minimum 1 min. delay) when the STOP key is pressed and automatically restart the pump when the unit starts normally.

To restart the unit after a temporary shutdown, enable the chilled-water pump and press the AUTO key. The unit will start normally, provided the following conditions exist:

- The Symbio™ 800 receives a call for cooling and the differential-to-start is above the setpoint.
- All system operating interlocks and safety circuits are satisfied.

Extended Shutdown Procedure

The following procedure is to be followed if the system is to be taken out of service for an extended period of time, e.g. seasonal shutdown:

1. Test the unit for refrigerant leaks and repair as necessary.
2. Open the electrical disconnect for the chilled water pump. Lock the switches in the "OPEN" position.

NOTICE

Pump Damage!

Failure to follow instructions could result in pump damage.

Lock the chilled water pump disconnects open and verify pump is off before draining water.

3. Close all chilled water supply valves. Drain the water from the evaporator.
4. With water drained from the evaporator, remove power from heaters as follows:
 - For units with model number digit 29 = 3, disable power upstream from the chiller.
 - For all other units, disconnect 115 power from evaporator heaters at terminals 1X8-1 and 1X8-2.

NOTICE

Heater Damage!

Failure to follow instructions could result in heater damage.

Do not apply power to the evaporator heaters when no water is present.

5. Open the main electrical disconnect and lock in the "OPEN" position.

NOTICE

Equipment Damage!

Failure to follow instructions could result in equipment damage.

Lock the disconnect in the "OPEN" position to prevent accidental start-up and damage to the system when it has been shut down for extended periods.

6. At least every three months (quarterly), check the refrigerant pressure in the unit to verify that the refrigerant charge is intact.

Seasonal Unit Start-Up Procedure

1. PRIOR to water being pumped into system, use gauges to verify positive pressure in the evaporator and condenser. Lack of pressure could indicate a system leak. When charging in the factory, approximately 95% of the refrigerant charge is isolated in the evaporator, and the other 5% is contained in the condenser and compressor. In the event that no pressure is present, contact local Trane service.
2. Close all drain valves and re-install the drain plugs in the evaporator.
3. Service the auxiliary equipment according to the start-up/maintenance instructions provided by the respective equipment manufacturers.
4. Close the vents in the evaporator chilled water circuits.
5. Open all the valves in the evaporator chilled water circuits.
6. Open all refrigerant valves or verify they are in the open condition.
7. If the evaporator was previously drained, vent and fill the evaporator and chilled water circuit. When all air is removed from the system (including each pass), install the vent plugs in the evaporator water boxes.
8. Check the adjustment and operation of each safety and operating control.
9. Refer to the sequence for daily unit start-up for the remainder of the seasonal start-up.

System Restart after an Extended Shutdown

NOTICE

Equipment Damage!

Failure to follow instructions could result in equipment damage.

Ensure that the compressor and oil sump heaters have been operating properly for a minimum of 24 hours before starting.

Follow the procedures below to restart the unit after extended shutdown:

1. Check refrigerant pressure as noted in Seasonal Unit Start-Up procedure.
2. Verify that the liquid line service valves, oil line, compressor discharge service valves and suction service valves are open (backseated).

NOTICE

Compressor Damage!

Failure to follow instructions below could cause catastrophic damage to the compressor.

Do not leave oil line shut off valve or the isolation valves closed on unit start-up.

3. Check the oil sump level. See the instructions in the "Maintenance," p. 102 chapter.
4. Fill the evaporator water circuit. Vent the system while it is being filled. Open the vent on the top of the evaporator and condenser while filling and close when filling is completed.

NOTICE

Proper Water Treatment Required!

The use of untreated or improperly treated water could result in scaling, erosion, corrosion, algae or slime.

Limit chloride below 300 ppm to avoid corrosion. Use the services of a qualified water treatment specialist to determine what water treatment, if any, is required. Trane assumes no responsibility for equipment failures which result from untreated or improperly treated water, or saline or brackish water.

5. Close the fused-disconnect switches that provides power to the chilled water pump.
6. Start the evaporator water pump and, while water is circulating, inspect all piping for leakage. Make any necessary repairs before starting the unit.
7. While the water is circulating, adjust the water flows and check the water pressure drops through the evaporator. See Evaporator Waterside Pressure Drop Curves in Installation Mechanical chapter, and water flow rates in General Data tables.
8. Verify proper operation of flow switch on the evaporator

waterbox.

- Stop the water pump. The unit is now ready for start-up.

Sequence of Operation

This section provides basic information on chiller operation for common events. Adaptive control algorithms are used on these chillers. This section illustrates common control sequences.

Software Operation Overview

The following figure is a diagram of the five possible software states. This diagram can be thought of as a state chart, with the arrows and arrow text, depicting the transitions between states:

- The text in the circles is the internal software designations for each state.
- The shading of each software state circle corresponds to the shading on the time lines that show the chiller's state.

There are five generic states that the software can be in:

- Power Up
- Stopped
- Starting
- Running
- Stopping

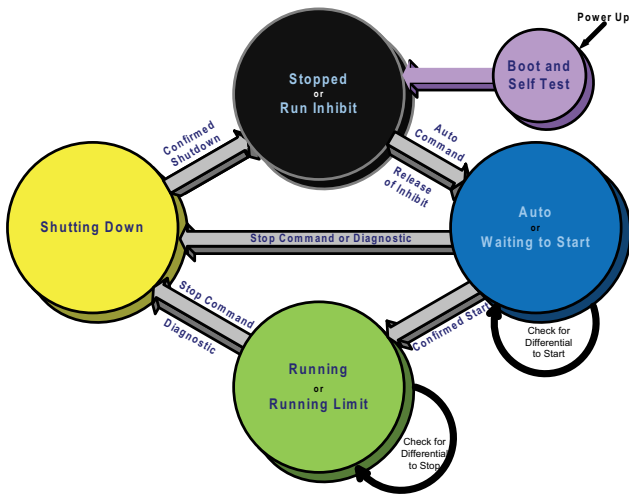

In the following diagrams:

- The time line indicates the upper level operating mode, as it would be viewed in the Tracer® AdaptiView™.
- The shading color of the cylinder indicates the software state.
- Text in parentheses indicates sub-mode text as viewed in the Tracer® AdaptiView™.
- Text above the time line cylinder is used to illustrate inputs to the Symbio™ 800. This may include user input to the Tracer® AdaptiView™ touch screen, control inputs from sensors, or control inputs from a generic BAS.
- Boxes indicate control actions such as turning on relays, or pulsing compressor load or unload solenoids.
- Smaller cylinders under the main cylinder indicate diagnostic checks.
- Text outside a box or cylinder indicates time-based functions.
- Solid double arrows indicate fixed timers.
- Dashed double arrows indicate variable timers.

Power Up Diagram

The following diagram shows the respective TD-7 AdaptiView™ screens during a power up of the Symbio™ 800 and display. This process takes 15 seconds for the Symbio™ 800, and 105 seconds for the display. On all power ups, the software model always will transition through the 'Stopped' Software state independent of the last mode. If the last mode before power down was 'Auto', the transition from 'Stopped' to 'Starting' occurs, but it is not apparent to the user.

Figure 41. Sequence of operation: power up diagram

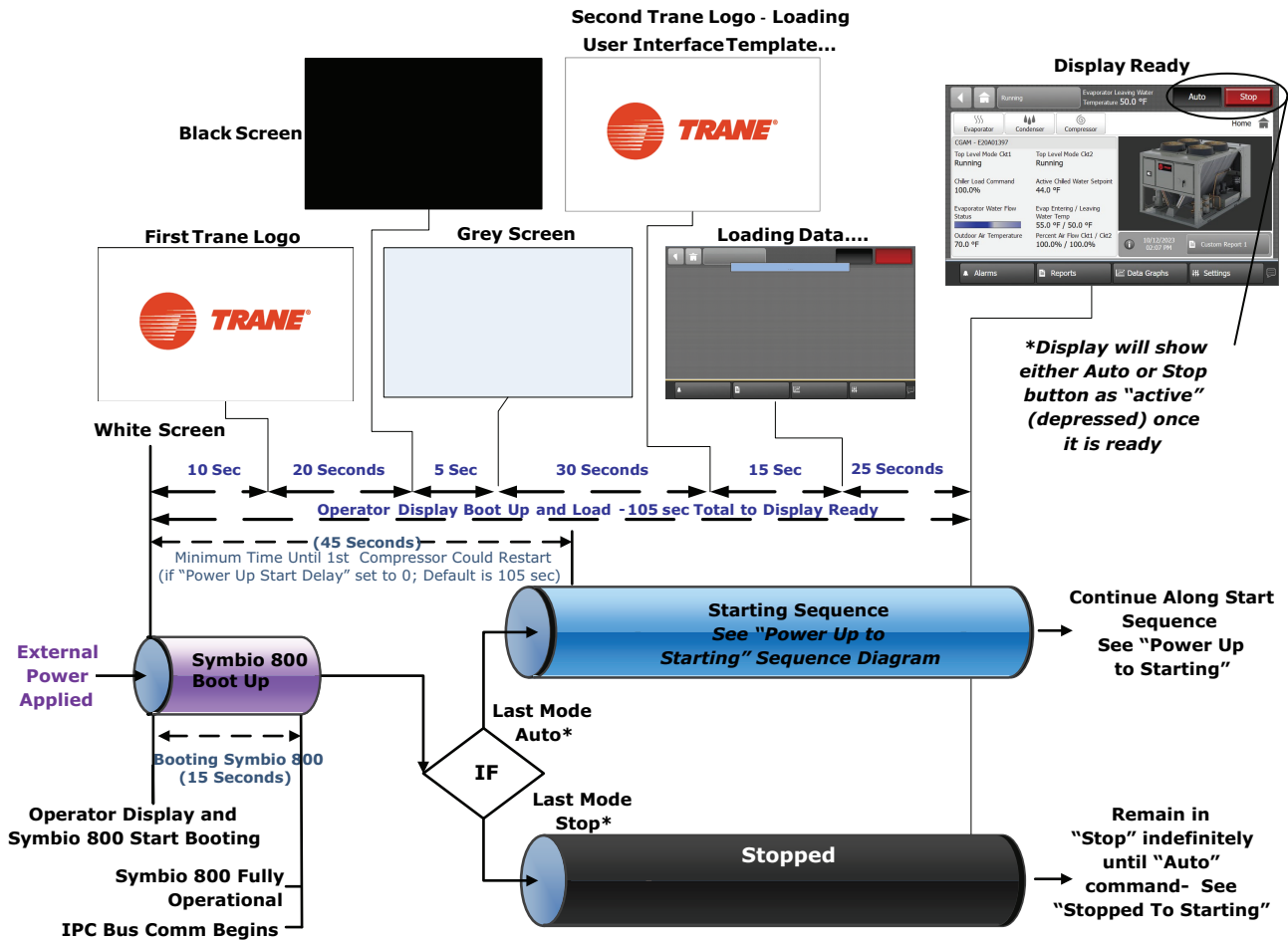

Power Up to Starting

The following diagram shows the timing from a power up event to energizing the first compressor. The shortest allowable time would be under the following conditions:

- No motor restart inhibit time left from subsequent starts
- Evaporator water flow occurs quickly with pump on command
- Power up Start Delay set to 0 minutes

- Need to cool (differential to start) already exists
- Oil level is detected immediately

The above conditions would allow for a minimum power up to starting the first compressor time of about 45 seconds. (Variations may exist due to options installed.)

Note: Do not start a chiller "cold". The oil heaters must be in operation for a sufficient length of time prior to first start.

Start-Up and Shutdown

Figure 42. Sequence of events: power up to starting

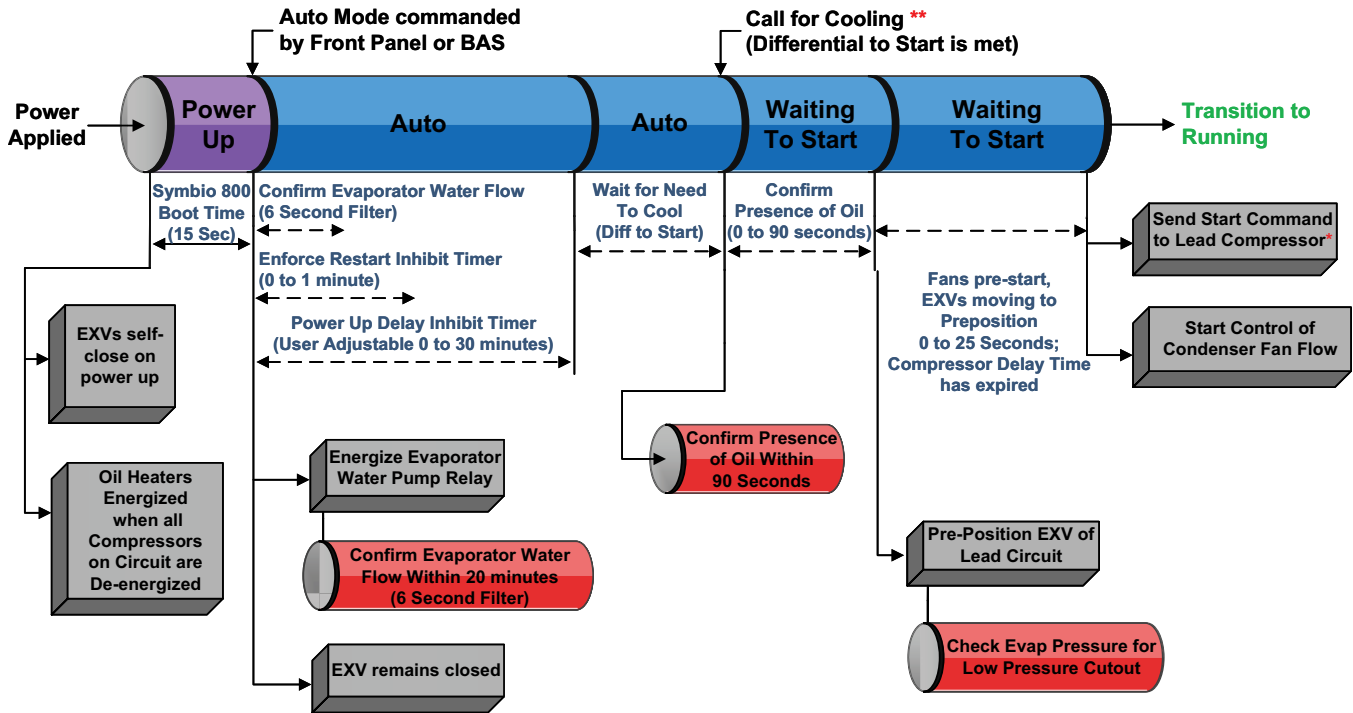

* Lead Compressor (and its lead circuit) is determined by staging algorithm – “Balanced”, “Circuit 1 Lead”, or “Circuit 2 Lead” selection – also influenced by lockouts, restart inhibit, or diagnostics present.

On a manifolded circuit, GP4 will be the first to start and last to stop; GP2 will not run by itself.

** If Free Cooling is available, it shall be the first level control to start. Total Free Cooling: balanced starts and hours or circuit x lead are available.

Stopped to Starting

The following diagram shows the timing from a stopped mode to energizing the first compressor. The shortest allowable time would be under the following conditions:

- No motor restart inhibit time left from subsequent starts

- Evaporator water flow occurs quickly with pump on command
- Need to cool (differential to start) already exists

The above conditions would allow a compressor to start in about 20 seconds.

Figure 43. Sequence of events: stopped to starting

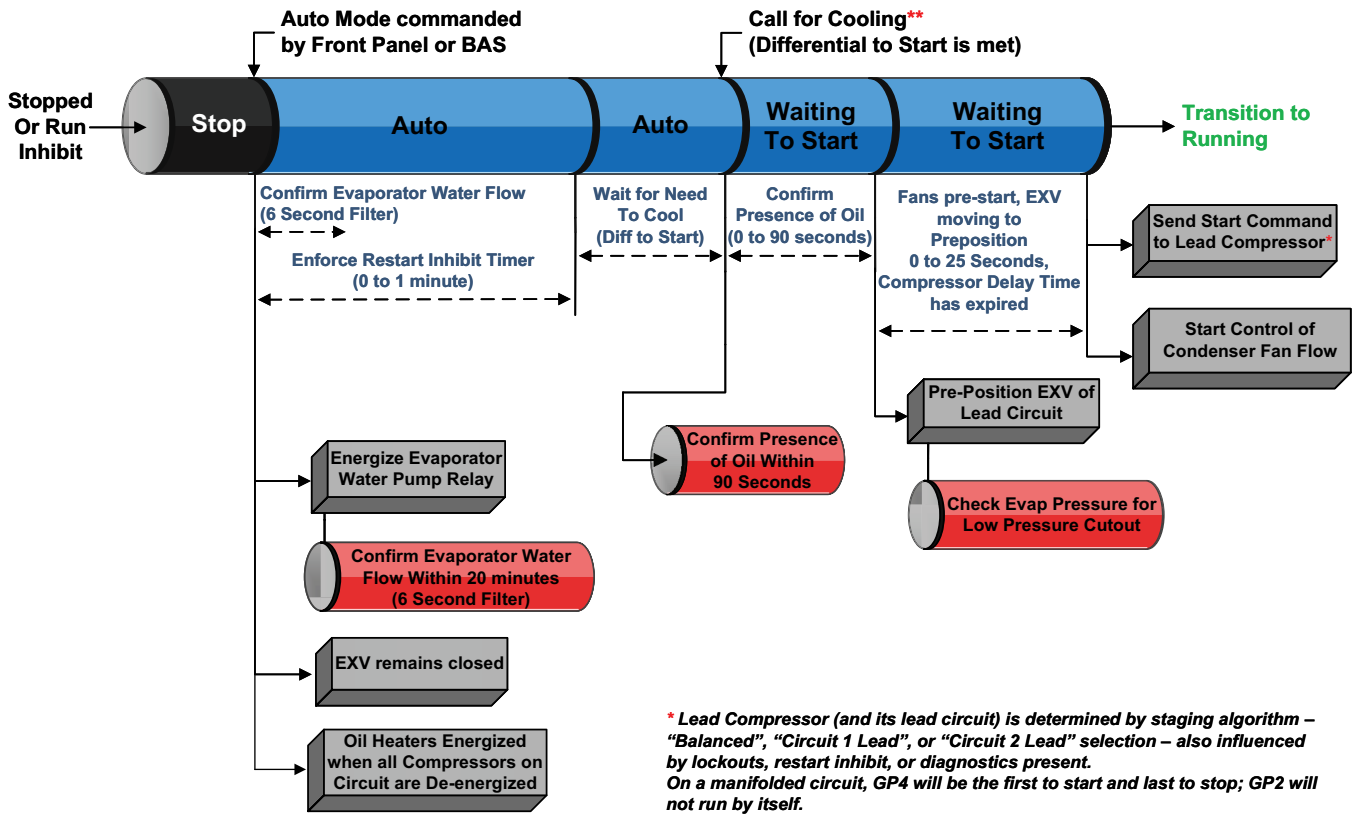

****Note: If Free Cooling is active, it will be the first stage of cooling to stage on.**

Lead Circuit Running — Increasing Load

The following diagram shows a typical start and run sequence for the lead compressor and its circuit.

Figure 44. Sequence of events: lead circuit running — increasing load

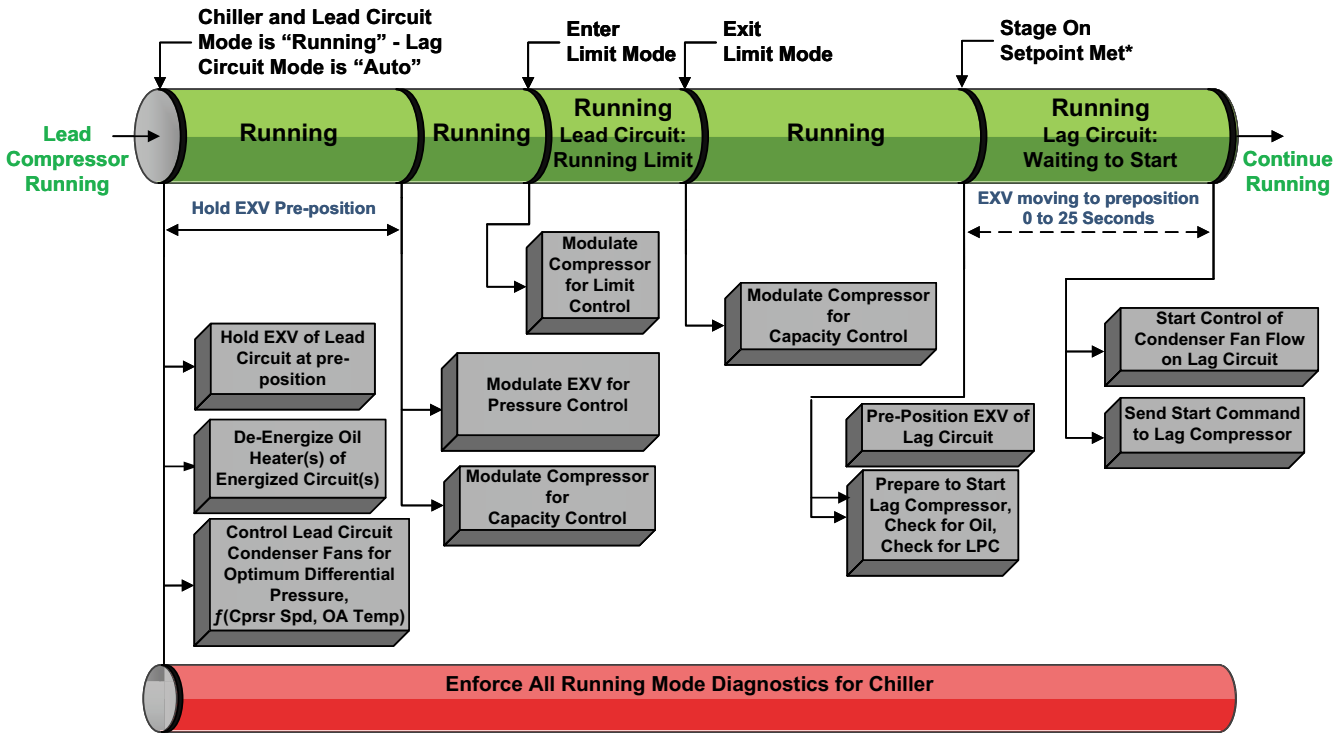

**Note: The decision to stage on or off another compressor is determined by the Average Running Compressor Load Command, Water Temperature Error, and Time Since Last Stage Circuit X Lead: XA compressor on the selected circuit will lead followed by a compressor on the alternate circuit, given an appropriately increasing chiller load. Additional compressors will alternate between lead and lag circuits. On a manifolded circuit, GP4 will be the first to start and last to stop; GP2 will not run by itself.*

Lag Circuit Running — Increasing Load

The following diagram shows a typical start and run sequence for the lag compressor and its circuit.

Figure 45. Sequence of operation: lag circuit running — increasing load

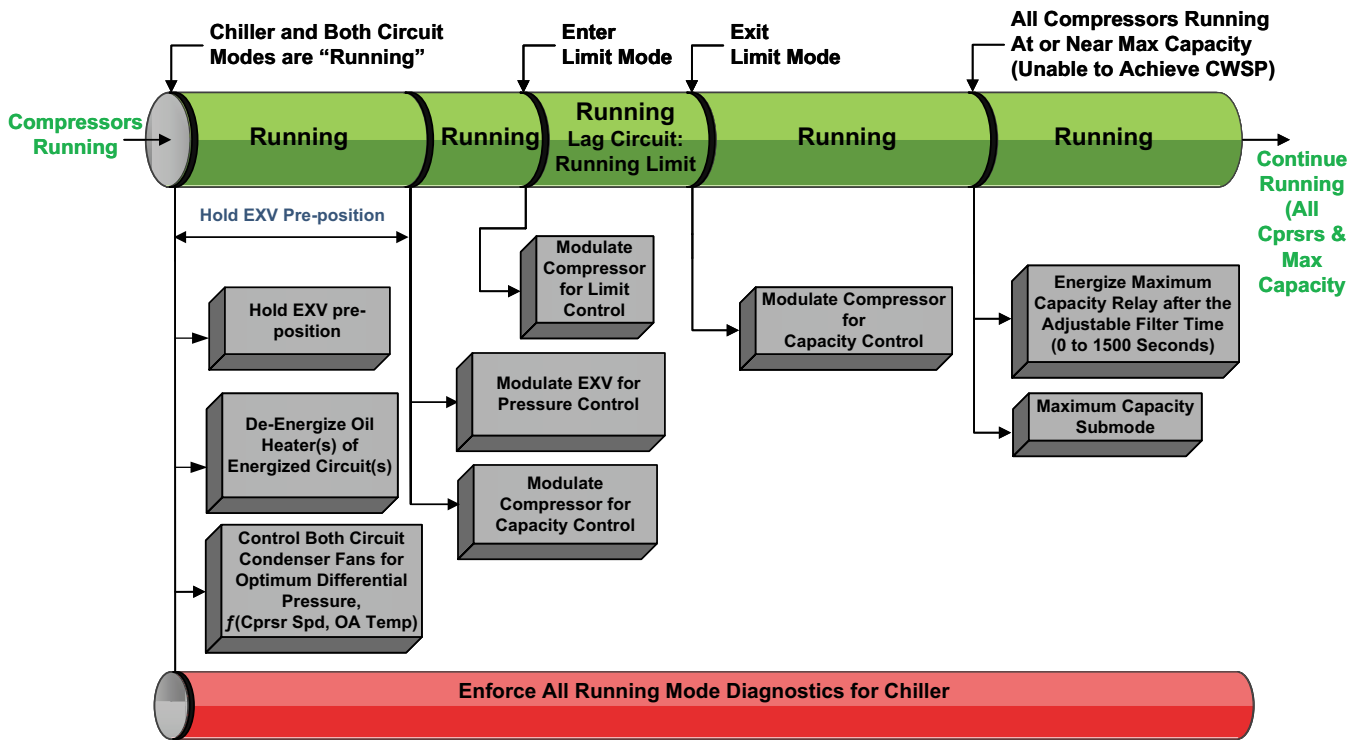

**Note: The decision to stage on or off another compressor is determined by the Average Running Compressor Load Command, Water Temperature Error, and Time Since Last Stage. On a manifolded circuit, GP4 will be the first to start and last to stop; GP2 will not run by itself.*

Satisfied Setpoint with Operational Pumpdown

The following diagram shows the normal transition from running to shutting down due to the evaporator leaving

water temperature falling below the differential to stop setpoint. It also outlines the termination criteria for operational pumpdown.

Figure 46. Sequence of events: satisfied setpoint with operational pumpdown

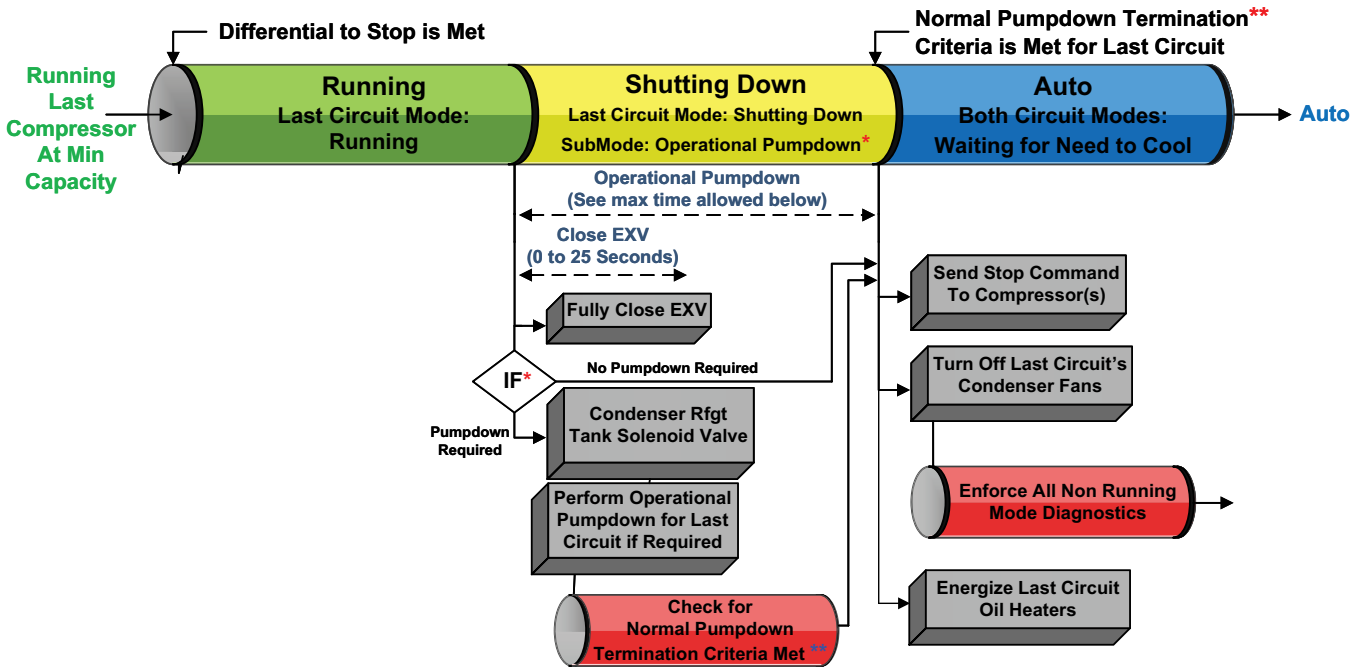

* Operational Pumpdown is required if the Outdoor Air Temperature is less than 50F, or the Entering Evaporator Water Temperature is greater than (outdoor air temperature – 10°F). With AFD, compressors will be at max speed for operational pumpdown.

** Operational pumpdown is terminated normally when:

- The evaporator (suction) pressure is at or below the "Pumpdown Termination Pressure" setting OR LERTC saturated pressure (32F for water [default]; -5F for glycol), which ever is greater
- The condenser (compressor discharge) pressure exceeds 315psia.
- The compressor pressure ratio exceeds 12.3
- The system differential pressure exceeds 265psid

** The maximum allowed time for Operational Pumpdown is Max Pumpdown Time setting (default to 120 sec.) * number of compressors configured on the circuit.

Full Load to Minimum Load

The following diagram shows the normal transition from full load to minimum load while the chiller is running.

Figure 47. Sequence of events: full load to minimum load

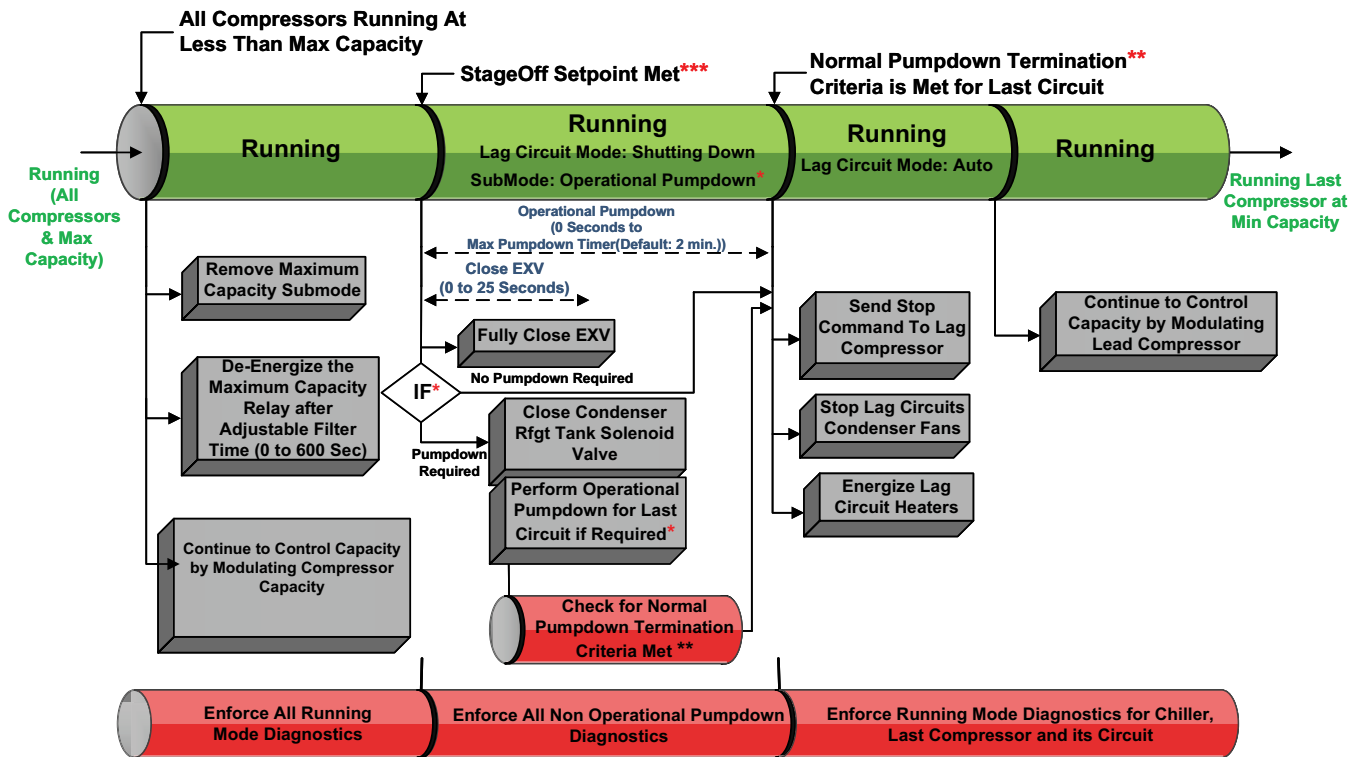

* & ** Operational Pumpdown Requirement and Termination - See Satisfied Setpoint Operational Pumpdown sequence diagram for specific criteria.

*** Note: The decision to stage off another compressor is determined by the Average Running Compressor Load Command, Water Temperature Error, and Time since Last Stage. Compressors will stage off in the reverse order they staged on. All fixed speed compressors will stage off before variable speed compressors stage off. On a manifolded circuit, GP4 will be the first to start and last to stop; GP2 will not run by itself.

Normal Shutdown to Stopped or Run Inhibit

The following diagram shows the transition from Running through a Normal (friendly) Shutdown. The dashed lines on

the top attempt to show the final mode if stop is selected via various inputs.

Figure 48. Sequence of events: normal shutdown to stopped or run inhibit

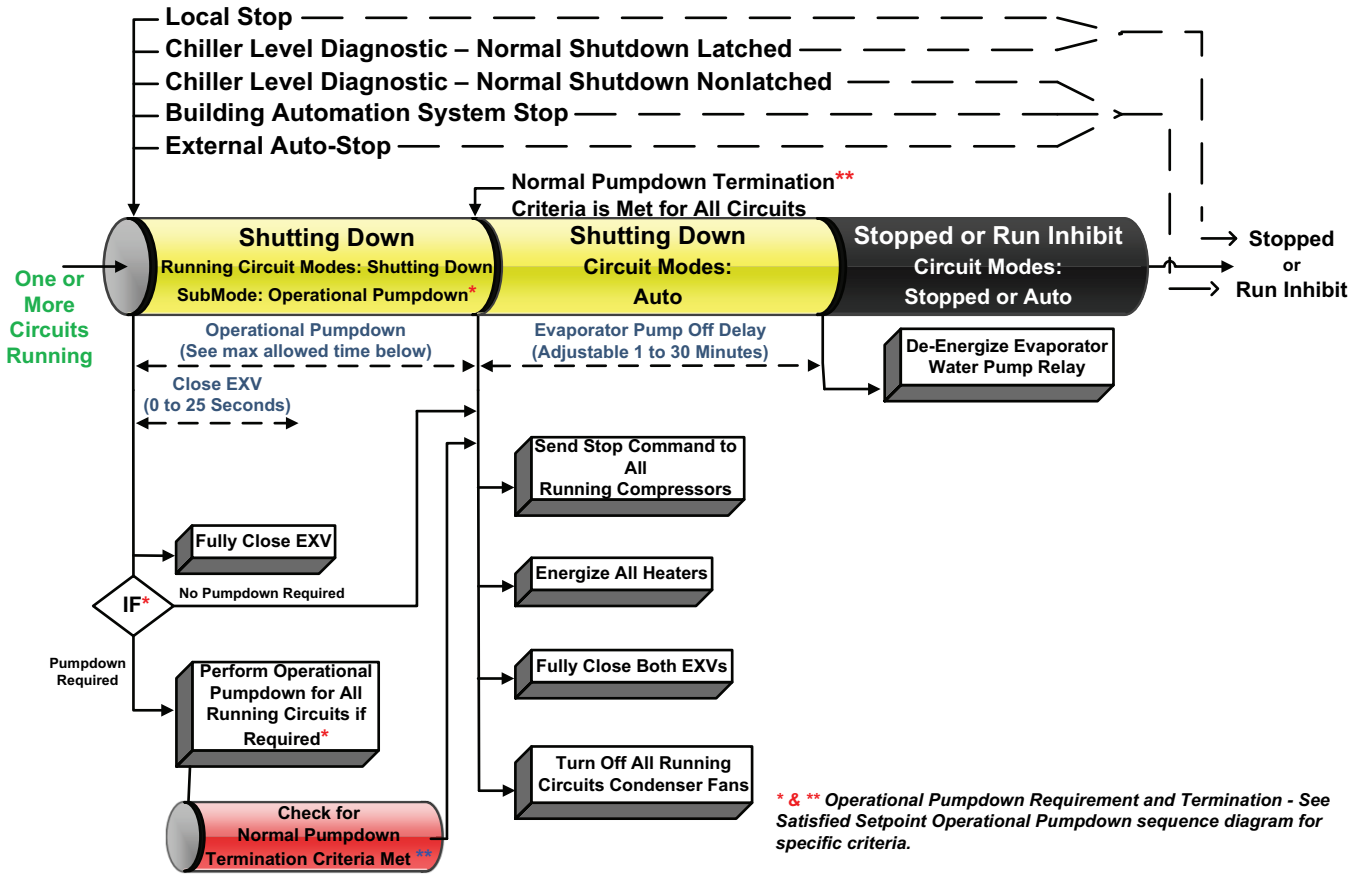

Note: If Free Cooling is active, the last stage of cooling to turn off will be Free Cooling.

Immediate Shutdown to Stopped or Run Inhibit

The following diagram shows the transition from Running through an Immediate Shutdown. The dashed lines on the

top attempt to show the final mode if stop is selected via various inputs.

Figure 49. Sequence of events: immediate shutdown to stopped or run inhibit

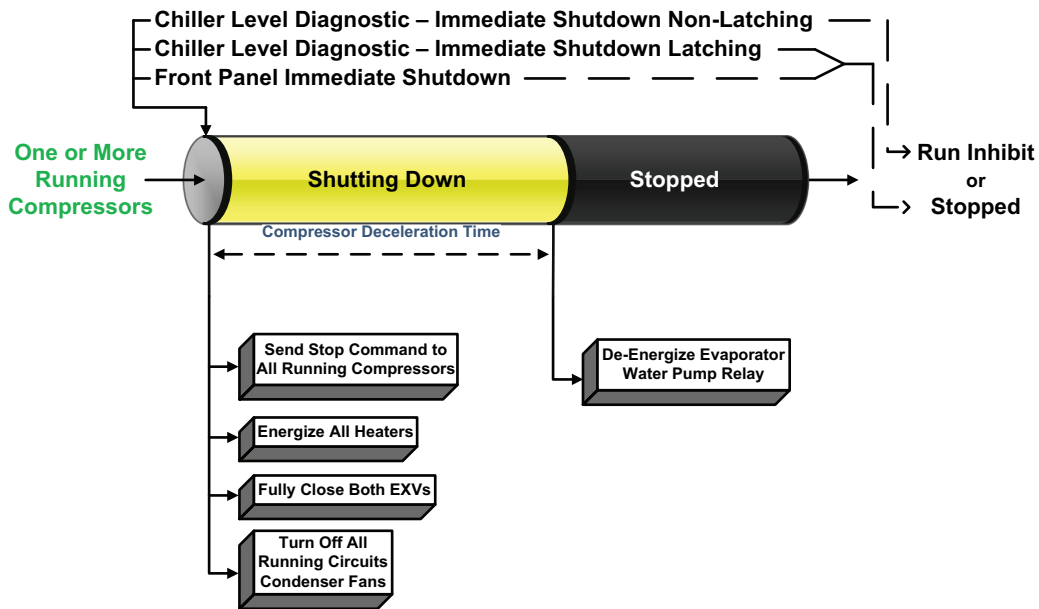

Ice Making (Running to Ice Making to Running)

The following diagram shows the transition from normal cooling to ice making, and back to normal cooling.

Figure 50. Sequence of events: ice making (running to ice making to running)

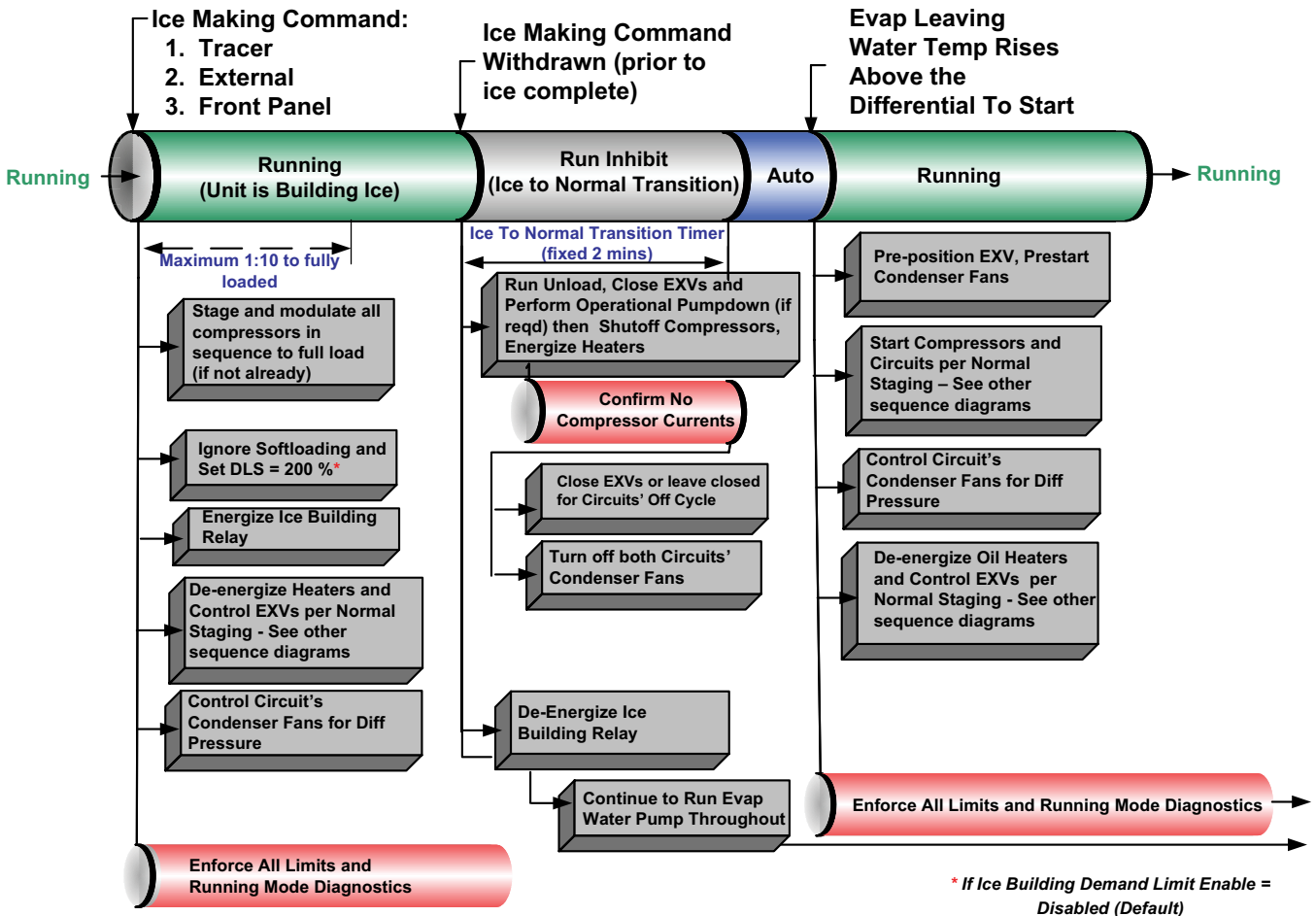

Ice Making (Stopped to Ice to Ice Making Complete)

The following diagram shows the transition from stopped to ice to ice making complete.

Figure 51. Sequence of events: ice making (stopped to ice to ice making complete)

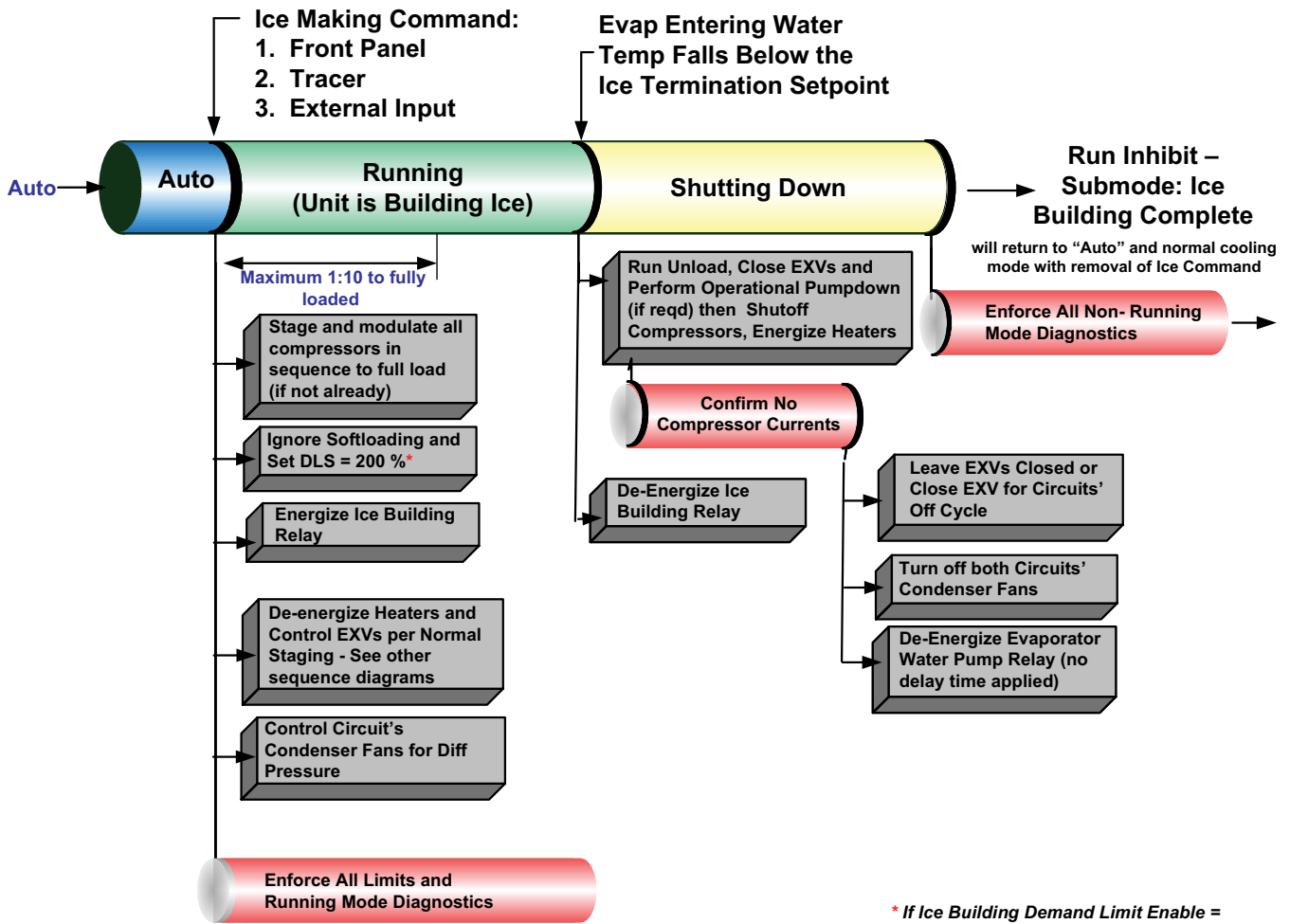

* If Ice Building Demand Limit Enable = Disabled (Default)



Maintenance

⚠ WARNING

Hazardous Voltage - Pressurized Flammable Fluid!

Failure to follow all electrical safety precautions could result in death or serious injury.

Do not operate compressor without terminal box cover in place.

The motors in the compressors have strong permanent magnet motors and have the capability to generate voltage during situations when the refrigerant charge is being migrated. This potential will be present at the motor terminals and at the output of the variable speed drives in the power panel.

Before removing compressor terminal box cover for servicing, or servicing power side of control panel, **CLOSE COMPRESSOR DISCHARGE SERVICE VALVE** and disconnect all electric power including remote disconnects. Discharge all motor start/run capacitors. Follow lockout/tagout procedures to ensure the power cannot be inadvertently energized. Verify with an appropriate voltmeter that all capacitors have discharged.

The compressor contains hot, pressurized refrigerant. Motor terminals act as a seal against this refrigerant. Care should be taken when servicing **NOT** to damage or loosen motor terminals.

⚠ WARNING

Pressurized Burning Fluid!

Failure to follow the instructions below could result in death or serious injury.

Do not operate compressor without terminal box cover in place.

The compressor contains hot, pressurized refrigerant. Motor terminals act as a seal against this refrigerant. Care should be taken when servicing **NOT** to damage or loosen motor terminals.

⚠ WARNING

Hazardous Voltage w/Capacitors!

Failure to disconnect power and discharge capacitors before servicing could result in death or serious injury.

Disconnect all electric power, including remote disconnects and discharge all motor start/run capacitors before servicing. Follow proper lockout/tagout procedures to ensure the power cannot be inadvertently energized. For variable frequency drives or other energy storing components provided by Trane or others, refer to the appropriate manufacturer's literature for allowable waiting periods for discharge of capacitors. Verify with a CAT III or IV voltmeter rated per NFPA 70E that all capacitors have discharged.

This section describes the basic chiller preventive maintenance procedures, and recommends the intervals at which these procedures should be performed. Use of a periodic maintenance program is important to ensure the best possible performance and efficiency.

Use an Operator Log (see Log and Check Sheet chapter) to record an operating history for unit. The log serves as a valuable diagnostic tool for service personnel. By observing trends in operating conditions, an operator can anticipate and prevent problem situations before they occur.

If unit does not operate properly during inspections, see Diagnostics chapter.

Recommended Maintenance

Weekly

While unit is running in stable conditions.

1. At AdaptiView™ TD-7 or Tracer® TU service tool, check pressure for evaporator, condenser and intermediate oil.
2. Observe liquid line sight glass on EXV. If liquid line sight glass has bubbles measure the subcooling entering the EXV. Subcooling should always be greater than 10°F for single compressor circuits, and 5°F for dual compressor circuits.
3. Inspect the entire system for unusual operation.
4. Inspect the condenser coils for dirt and debris. If the coils are dirty, see Condenser Coil Cleaning section of Maintenance chapter.

NOTICE

Coil Damage!

Use of detergents could cause damage to coils. Do not use detergents to clean coils. Use clean water only.

Monthly

1. Perform all weekly maintenance procedures.
2. Record the system subcooling.

Annual

1. Perform all weekly and monthly procedures.
2. Check oil level while unit is off. See Maintenance chapter.
3. Perform pH test of drive cooling fluid. See pH Test section of Maintenance chapter.
4. Have a qualified laboratory perform a compressor oil analysis to determine system moisture content and acid level.

5. Contact a Trane service organization to leak test the chiller, to check operating and safety controls, and to inspect electrical components for deficiencies.
6. Clean and repaint any areas that show signs of corrosion.
7. Clean the condenser coils. See Condenser Coil Cleaning section of Maintenance chapter.

NOTICE

Coil Damage!

Use of detergents could cause damage to coils. Do not use detergents to clean coils. Use clean water only.

Refrigerant and Oil Charge Management

Proper oil and refrigerant charge is essential for proper unit operation, unit performance, and environmental protection. Only trained and licensed service personnel should service the chiller.

The following table lists baseline measurements for chillers running at AHRI standard operating conditions. If chiller measurements vary significantly from values listed below, problems may exist with refrigerant and oil charge levels. Contact your local Trane office.

Note: *Low temperature applications units will have values that vary from the following table. Contact your local Trane office for more information.*

Table 29. Typical baselines (AHRI conditions)

Measurement	Baseline
Evaporator Pressure	51 psia
Evaporator Approach	3.4°F average
EXV Position	45-65% open
Evaporator Temp - entering	54°F
Evaporator Temp - leaving	44°F
Discharge Superheat	16.5°F
Condenser Pressure	212 psia
Subcooling	10 to 20°F

Lubrication System

The lubrication system has been designed to keep most of the oil lines filled with oil as long as there is a proper oil level in the oil sump.

Oil Sump Level Check

The oil level in the sump can be measured to give an indication of the system oil charge. Follow the procedures below to measure the level.

1. Run the unit as near to full load as possible for a minimum of 30 minutes. For an accurate reading, 40 or more minutes at full load with normal/steady discharge superheat readings and no limits/warnings is recommended. Assessing oil charge after running at minimum or low loads may lead to an inaccurate reading.
2. Cycle the compressors off.
3. Let the chiller sit (powered, but off line) to allow the oil separator heater to boil off the refrigerant that may be in the oil separator. An initial assessment of the oil separator level may be made after 30 minutes of heater ON dwell time, but oil charge adjustments should not be made without allowing the oil heaters to run for a minimum of 4 hours.

NOTICE

Equipment Damage!

Operating compressors with service valves open will result in severe oil loss and equipment damage. Never operate the compressor with the sight glass service valves opened. Close the valves after checking the oil level.

4. Attach a 3/8 inch or 1/2 inch hose with a sightglass in the middle to the oil sump service valve (1/4 inch flare) and the oil separator service valve (1/4 inch flare). See the following figure for valve locations.

Note: *High pressure rated clear hose with appropriate fittings can help speed up the process. Hose must be rated to withstand system pressures as found on unit nameplate.*

Figure 52. Oil service valves

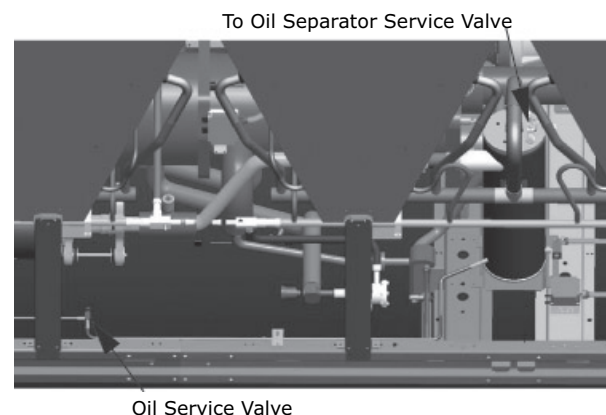

5. After the unit is off line for 30 minutes, move the sightglass along the side of the oil sump.
6. The nominal oil level from the bottom of the oil separator should be as shown in the following table and figure. Depending on running conditions and oil heater dwell time, some deviation from nominal levels is expected.

Important: If level is less than 4 inches from the bottom of the oil separator, contact your local Trane office.

Unit Size (tons)	Oil Separator Size (in)	Nominal Oil Charge Height (in)
150 to 200	10	9.0
225 to 330	12	8.5
375 to 550	12	8.5
	14	9.7

Figure 53. Nominal oil level

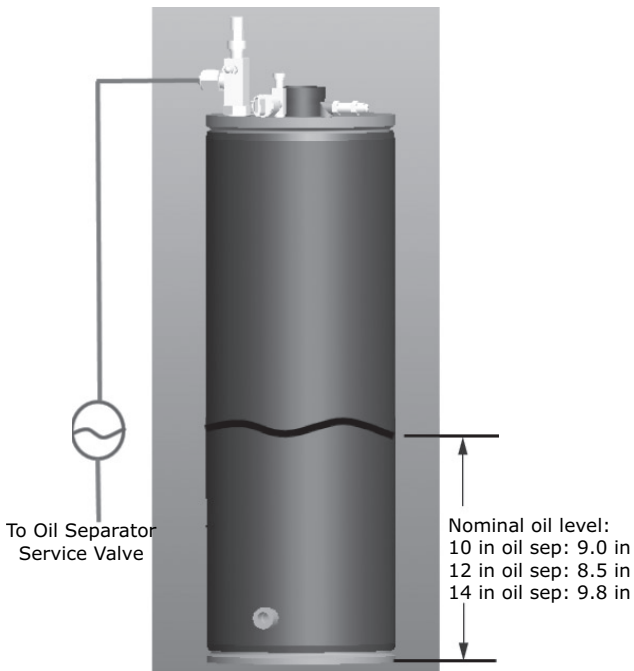

Condenser Coil Cleaning

For information regarding the proper microchannel coil cleaning procedure, see *Microchannel Coil Servicing Guidelines Service Guide* (RF-SVG001*-EN).

Coil Cleaning Interval

Clean condenser coils at least once a year or more frequently if it is in a **dirty** environment. A clean condenser coil will help maintain chiller operating efficiency.

Cleaning Air Side of Coils

NOTICE

Coil Damage!

Use of coil cleaning agents on uncoated coils could cause damage to coils.

Do not use coil cleaning agents to uncoated clean coils. Use clean water only.

Do not use detergents to clean the air side of coils. Use clean water only. Clean from inside out by removing end panels.

Cleaning Microchannel Coils

For proper operation, microchannel condenser coils must be cleaned regularly. Eliminate pollution and other residual material help to extend the life of the coils and the

Regular coil maintenance, including annual cleaning, enhances the unit's operating efficiency by minimizing compressor head pressure and amperage draw. The condenser coil should be cleaned at minimum once each year, or more if the unit is located in a "dirty" or corrosive environment.

NOTICE

Coil Damage!

Use of detergents could cause damage to coils.

Do not use detergents to clean coils. Use clean water only.

Cleaning with cleansers or detergents is strongly discouraged. Water should prove sufficient. Any breach in the tubes can result in refrigerant leaks.

⚠ WARNING

Hazardous Voltage w/Capacitors!

Failure to disconnect power and discharge capacitors before servicing could result in death or serious injury.

Disconnect all electric power, including remote disconnects and discharge all motor start/run capacitors before servicing. Follow proper lockout/tagout procedures to ensure the power cannot be inadvertently energized. For variable frequency drives or other energy storing components provided by Trane or others, refer to the appropriate manufacturer's literature for allowable waiting periods for discharge of capacitors. Verify with a CAT III or IV voltmeter rated per NFPA 70E that all capacitors have discharged.

1. Disconnect power to the unit.

Use a soft brush or vacuum to remove base debris or surface loaded fibers from both sides of the coil.

Note: When possible, clean the coil from the opposite direction of normal air flow (inside of unit out) to push debris out.

Using a sprayer and water ONLY, clean the coil following the guidelines below.

- a. Sprayer nozzle pressure should not exceed 580 psi.
- b. The maximum source angle should not exceed 25° to the face of the coil. See figure below. For best results spray the microchannel perpendicular to face of the coil.

- c. Spray nozzle should be approximately 1 to 3 inches from the coil surface.
- d. Use at least a 15° fan type of spray nozzle.

Note: To avoid damage from the spray wand contacting the coil, make sure the 90° attachment does not come in contact with the tube and fin as abrasion to the coil could result.

Cleaning the Evaporator

Because the evaporator is typically part of a closed circuit, it does not accumulate appreciable amounts of scale or sludge with properly treated working fluids. However, if cleaning is deemed necessary, chemical and mechanical means are both acceptable. If using chemical means, any and all materials used in the external circulation system, the quantity of the solution, the duration of the cleaning period, and any required safety precautions should be approved by the company furnishing materials or performing the cleaning. When using mechanical means, care must be taken in selecting the cleaning method and equipment, as well as appropriate brush type and size if used. The evaporator utilizes highly enhanced tubes which can be damaged by some cleaning methods, resulting in a loss of system performance.

In particular, evaporators in units larger than 300 nominal tons may be equipped with a highly enhanced "micro" structure that will not behave like a typical helical structure when cleaned mechanically. This may require specialized equipment or methods to force tube cleaning heads through the tubes. In these instances, determination of brush/head type and size is critical, as using an oversized brush/head may damage the tube enhancement, while using a brush/head that is too small could result in incomplete cleaning.

Pump Package

Pumps not immediately placed into service, or removed from service and stored, must be properly prepared to prevent excessive rusting.

- Pump port protection plates must not be removed until the pump is ready to connect to the piping.
- Rotate the shaft periodically (at least monthly) to keep rotating element free and bearings fully functional.
- For long term storage (3 months or longer), prevent internal rust buildup and possibility of freezing by performing the following steps:
 - Remove the casing plugs.
 - If water is to be drained:
 - Disconnect evaporator and piping heaters.
 - Drain or blow out all water.
 - As an optional step, it is acceptable to rustproof or pack the casing with moisture absorbing material and cover the flanges.

When returning pumps to service.

- Remove drying agent from the pump, if used.
- Reinstall casing plugs.
- If water had been drained:
 - Refill water.
 - Reconnect evaporator and piping heaters.

A blow-down valve may be installed on the Suction Guide drain connection. Suction Guides are supplied with an inlet tapped gauge connection. Monitoring the differential pressure across the fitting, from the suction guide inlet gauge to the pump inlet gauge, will alert the operator should the strainer need to be removed and cleaned.

NOTICE

Equipment Damage!

Failure to follow instructions below could result in equipment damage.

The factory installed temporary fine-mesh start-up strainer must be removed following system clean up.

After all debris has been removed from the system, or a maximum of 24 running hours, stop the pump and close the pump isolation valves. Drain the Suction Guide by removing the drain plug or opening the blowdown valve, if installed. Remove the Suction Guide cover and remove the strainer assembly from the valve body. A temporary fine-mesh start-up strainer is tack-welded to the permanent stainless steel strainer. This temporary strainer should now be removed from the permanent strainer. The fine-mesh strainer is designed to remove small particulate from new piping systems and could easily clog with debris if left in place. This will be detrimental to the operation of the pump. Replace the permanent strainer into the fitting body, once the temporary strainer is removed. Inspect the cover O-ring and replace if necessary. Replace the cover into the body. Ensuring that the strainer is properly seated, tighten the cover bolts diagonally, evenly and firmly.

Figure 54. Pump package

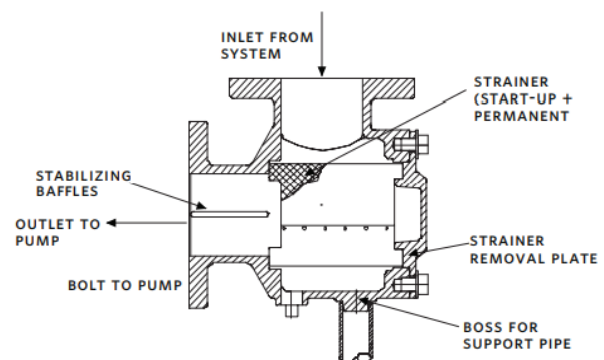



Free-Cooling Coil

Free-Cooling Coil Cleaning

Regular coil maintenance enhances the unit's operating efficiency by optimizing free-cooling heat transfer and amperage draw. The free cooling coil should be cleaned at minimum once each year, or more if the unit is located in a dirty or corrosive environment.

Free-cooling coil cleaning process is the same as condenser coil cleaning.

Free-Cooling Fluid Management

NOTICE

Equipment Damage!

Failure to follow instructions below could result in equipment damage.

DO NOT USE UNTREATED WATER. Glycol solution must be utilized with the Direct Free Cooling options and in the free cooling loop of Indirect Free Cooling options. Glycol percentage should be based on freeze avoidance requirements. The glycol solution requires an inhibitor package to be carefully chosen with the aid of qualified water treatment specialist to abate corrosion in a mixed metal system.

The building glycol loop should not be vented to atmosphere. A closed system is required to limit oxidation potential within the loop.

Make-up water should be avoided.

NOTICE

Coil Damage!

Failure to follow instructions below could result in free-cooling coil freeze.

For units with free-cooling option, introduction of uninhibited water into the system is not recommended, as it could lead to internal corrosion and risk of coil freeze. To avoid free-cooling coil damage:

- If the building loop needs to be charged with water for testing purposes, isolate free-cooling coils by closing free-cooling service shut-off valve and modulating valve.
- Completely drain any water inadvertently introduced into the system, and replace with glycol fluid as required for the free-cooling system.
- If water was introduced for hydronic testing, and was not immediately replaced with glycol solution, a glycol (freeze inhibitor) solution must be introduced to the free-cooling system/ coils for any long term storage.

The free cooling option circuit consists of copper, carbon steel, cast iron, zinc, EPDM rubber, brass, and Aluminum

AA3102, AA3003, AA4045. Direct free cooling units will also have the addition of other materials that may be in the building loop connected to the chiller. An inhibitor is required in the glycol/water system to passivate metal surfaces and decrease the corrosion rate. The effectiveness of a corrosion inhibitor depends on the fluid composition and quantity of water. Avoid system fluid dilution and ensure a level of reserve alkalinity is maintained. Glycol fluid should be free from foreign solid particles. A maintenance schedule should be selected per the glycol manufacturer's requirements to insure adequate protection during product usage.

Reinstallation of Compressor Mounting Bolts

Units with InvisiSound™ Ultimate Only (Model Number Digit 13 = E)

If compressor removal or unit move is required on a unit with InvisiSound™ Ultimate option, reinstall compressor mounting bolts which were removed per installation or maintenance instructions.

Servicing Chiller Roof

⚠ WARNING

Do Not Climb on Top of Unit!

Failure to follow these instructions could result in technician falling off the equipment which could result in death or serious injury.

Do not climb on roof to service unit. Use service tools designed to access top of chiller.

Service tools are available to access top of chiller. Entry on chiller roof is not required.



Diagnostics

General Diagnostics Information

Diagnostic Name and Source: Name of Diagnostic and its source. The variable "x" in the AFD diagnostic name string denotes a circuit designator (either 1 or 2). With that exception, this is the exact text used in the User Interface and/or Service Tool displays.

Affects Target: Defines the "target" or what is affected by the diagnostic. Usually either the entire Chiller, or a particular Circuit or Compressor is affected by the diagnostic (the same one as the source), but in special cases functions are modified or disabled by the diagnostic. "None" implies that there is no direct affect to the chiller, sub components or functional operation.

Design Note: Functions that are affected by a diagnostic are simply reported as "chiller or circuit x" targets in Tracer® TU and on the Alarms page of the AdaptiView™ display, even though only a specific function and not the entire circuit or chiller would be effected.

Severity: Defines the severity of the above effect. Immediate means immediate shutdown of the affected portion, Normal means normal or friendly shutdown of the affected portion, Special Action means a special action or mode of operation (limp along) is invoked, but without shutdown, and Info means an Informational Note or Warning is generated. Design Note: Tracer TU does not support display of "Special Action", on its Diagnostics pages, so that if a diagnostic has a special action defined in the table below, it will be displayed only as "Informational

Warning" as long as no circuit or chiller shutdown results. If there is a shutdown and special action defined in the table, then the Tracer TU Diagnostics Page display will indicate the shutdown type only.

Persistence: Defines whether or not the diagnostic and its effects are to be manually reset (Latched), or can be either manually or automatically reset when and if the condition returns to normal (Nonlatched).

Active Modes [Inactive Modes]: States the modes or periods of operation that the diagnostic is active in and, as necessary, those modes or periods that it is specifically "not active" in as an exception to the active modes. The inactive modes are enclosed in brackets, []. Note that the modes used in this column are internal and not generally announced to any of the formal mode displays.

Criteria: Quantitatively defines the criteria used in generating the diagnostic and, if nonlatching, the criteria for auto reset.

Reset Level: Defines the lowest level of manual diagnostic reset command which can clear the diagnostic. The manual diagnostic reset levels in order of priority are: Local or Remote. For example, a diagnostic that has a reset level of Remote, can be reset by either a remote diagnostic reset command or by a local diagnostic reset command.

AFD Diagnostics

Table 30. Diagnostics — AFD

Diagnostic Name and Source	Affects Target	Severity	Persistence		Active Modes [Inactive Modes]	Criteria	Reset Level
			Controller	AFD ^(a)			
AFD Bus Over Voltage - xA	Cprsr	Immediate	NonLatch	Momentary NonLatch	All	TR200 Alarm Code (A7), Alarm Word: 1, Bit: 11, Dec: 2048 If the intermediate circuit voltage exceeds the limit, the adjustable frequency drive trips after a time.	Remote
AFD Bus Under Voltage - xA	Cprsr	Immediate	NonLatch	Momentary NonLatch	All	TR200 Alarm Code (A8), Alarm Word: 1, Bit: 10, Dec: 1024 If the intermediate circuit voltage (DC) drops below the undervoltage limit, the adjustable frequency drive checks if a 24 V backup supply is connected. If no 24 V backup supply is connected, the adjustable frequency drive trips after a fixed time delay.	Remote

Table 30. Diagnostics — AFD (continued)

Diagnostic Name and Source	Affects Target	Severity	Persistence		Active Modes [Inactive Modes]	Criteria	Reset Level
			Controller	AFD ^(a)			
AFD Comm Loss: Main Processor - xA	Cprsr	Immediate	NonLatch	NonLatch	All	TR200 Alarm Code (W17), Alarm Word: 1, Bit: 4, Dec: 16 TR200 detected communication loss to unit controller known as Control Word Timeout warning on TR200. (Note: In case where the TR200 losses communication with the unit controller, the UC will not see this diagnostic via the alarm word. This has been included even though UC will most likely not see this alarm.)	Remote
AFD Fault Mains - xA	Cprsr	Immediate	NonLatch	Momentary NonLatch	All	TR200 Alarm Code (A36), Alarm Word: 1, Bit: 24, Dec: 16777216 Active if the supply voltage to the adjustable frequency drive is lost.	Remote
AFD General Fault - xA	Cprsr	Immediate	NonLatch ^(b)	Varies	All	This is a catch-all group for any faults in alarm words 1 or 2 that are not listed here. These faults are unlikely to occur. They are treated with immediate attention since they are not expected.	Local ^(c)
AFD Ground Fault - xA	Cprsr	Immediate	Latch	Latch (Trip Lock)	All	TR200 Alarm Code (A14), Alarm Word: 1, Bit: 2, Dec: 4 There is a discharge from the output phases to ground, either in the cable between the adjustable frequency drive and the motor or in the motor itself.	Local
AFD Harmonic Filter Over Temperature - xA	Cprsr	Immediate	NonLatch	Momentary NonLatch	All	TR200 Alarm Code (A60), Alarm Word: 2, Bit: 12, Dec: 4096 The AFD Harmonic Filter temperature has exceeded the maximum allowed value. This diagnostic is also non-latching on the AFD itself. The drive calls alarm 60 because that is tied to I/O pins 12 and 18, which function as a safety interlock. <i>Note that on the TR200 drive this diagnostic will populate as [A60] External Hardware Interlock.</i>	Remote
AFD High Pressure Cutout - xA	Cprsr	Immediate	Latch	Latch (Trip Lock)	All	TR200 Alarm Code (A68), Alarm Word: 1, Bit: 30, Dec: 1073741824 The respective drive's Safe Stop circuitry was activated (open circuit). The respective compressor's High Pressure Cutout Switch is wired into this circuit, and will cause an immediate shutdown of the drive and compressor in the event of an HPC trip.	Local
AFD High Torque - xA	Cprsr	Immediate	NonLatch	Momentary NonLatch	Running	TR200 Alarm Code (A12), Alarm Word: 1, Bit: 6, Dec: 64 The torque is higher than the value in par.4-16 Torque Limit Motor Mode.	Remote
AFD Initialized - xA	Cprsr	Immediate	NonLatch	Momentary NonLatch	All	TR200 Alarm Code (A80), Alarm Word: 1, Bit: 29, Dec: 536870912 Parameter settings are initialized to default settings after a manual reset.	Remote
AFD Internal Fault - xA	Cprsr	Immediate	Latch	Latch (Trip Lock)	All	TR200 Alarm Code (A38), Alarm Word: 1, Bit: 17, Dec: 131072 This fault could occur from various situations, please contact engineering.	Local

Table 30. Diagnostics — AFD (continued)

Diagnostic Name and Source	Affects Target	Severity	Persistence		Active Modes [Inactive Modes]	Criteria	Reset Level
			Controller	AFD ^(a)			
AFD Inverter Heatsink Over Temperature - xA	Cprsr	Immediate	Latch	Latch (Trip Lock)	Running	TR200 Alarm Code (A29), Alarm Word: 1, Bit: 1, Dec: 2 The maximum temperature of the heatsink has been exceeded.	Local
AFD Locked Rotor - xA	Cprsr	Immediate	Latch	Latch (Trip Lock)	Running	TR200 Alarm Code (A204), Alarm Word: 2, Bit: 29, Dec: 536870912 A multi-motor overload situation was detected, which could be due to, e.g., a locked rotor.	Local
AFD Mains Phase Loss - xA	Cprsr	Immediate	Latch	Latch (Trip Lock)	All	TR200 Alarm Code (A4), Alarm Word: 1, Bit: 14, Dec: 16384 A phase is missing on the supply side, or the line voltage imbalance is too high. This message also appears for a fault in the input rectifier on the adjustable frequency drive.	Local
AFD Missing Motor - xA	Cprsr	Immediate	NonLatch	Momentary NonLatch	All	TR200 Alarm Code (A203), Warning Word: 2, Bit: 10, Dec: 1024 A multi-motor underload situation was detected, this could be due to, for example, a missing motor.	Remote
AFD Motor Current Overload - xA	Cprsr	Immediate	Latch	Latch (Trip Lock)	Running	TR200 Alarm Code (A13), Alarm Word: 1, Bit: 5, Dec: 32 The inverter peak current limit (approx. 200% of the rated current) is exceeded.	Local
AFD New Spare Parts - xA	Cprsr	Immediate	Latch	Latch (Trip Lock)	All	TR200 Alarm Code (A250), Alarm Word: 2, Bit: 2, Dec: 4 The power or switch mode power supply has been exchanged. The adjustable frequency drive type code must be restored in the EEPROM. Please contact engineering.	Local
AFD Option Configuration Change - xA	Cprsr	Immediate	NonLatch	Momentary NonLatch	All	TR200 Alarm Code (A67), Alarm Word: 1, Bit: 28, Dec: 268435456 One or more options have either been added or removed since the last power-down.	Remote
AFD Output Phase U Loss - xA	Cprsr	Immediate	Latch	Latch (Trip Lock)	Running	TR200 Alarm Code (A30), Alarm Word: 1, Bit: 19, Dec: 524288 Motor phase U between the adjustable frequency drive and the motor is missing.	Local
AFD Output Phase V Loss - xA	Cprsr	Immediate	Latch	Latch (Trip Lock)	Running	TR200 Alarm Code (A31), Alarm Word: 1, Bit: 20, Dec: 1048576 Motor phase V between the adjustable frequency drive and the motor is missing.	Local
AFD Output Phase W Loss - xA	Cprsr	Immediate	Latch	Latch (Trip Lock)	Running	TR200 Alarm Code (A32), Alarm Word: 1, Bit: 21, Dec: 2097152 Motor phase W between the adjustable frequency drive and the motor is missing.	Local

Table 30. Diagnostics — AFD (continued)

Diagnostic Name and Source	Affects Target	Severity	Persistence		Active Modes [Inactive Modes]	Criteria	Reset Level
			Controller	AFD ^(a)			
AFD Over Temperature - xA	Cprsr	Immediate	NonLatch	Momentary NonLatch	Running	TR200 Alarm Code (A10), Alarm Word: 1, Bit: 8, Dec: 256 According to the electronic thermal protection (ETR), the motor is too hot. The fault is that the motor is overloaded by more than 100% for too long.	Remote
AFD Short Circuit - xA	Cprsr	Immediate	Latch	Latch (Trip Lock)	All	TR200 Alarm Code (A16), Alarm Word: 1, Bit: 12, Dec: 4096 There is short-circuiting in the motor or on the motor terminals.	Local

- (a) **Latch (Trip Lock)** - Requires reset command from the unit controller (via Modbus communication) or from TR200 keypad and power cycle of the drive to reset alarm.
Momentary NonLatch - Drive is programmed to automatically reset the alarm. If drive automatic reset sequence is exhausted, alarm will latch, requiring a manual reset.
NonLatch - True non-latching diagnostic where reset is not required to clear the alarm.
- (b) AFD General Fault - xA intentionally has the Controller Persistence set to NonLatch since this catch-all group that can have both latching and non-latching TR200 alarms. The diagnostic will not be latched by the UC, but instead follow the AFD. AFD will protect itself and the compressor and will require a manual reset if needed.
- (c) AFD General Fault - xA Reset Level is set to Local, and Persistence is set to NonLatch to emphasize recommended user attention when an unexpected AFD alarm occurs.

Starter Diagnostics

Table 31. Diagnostics — Starter

Diagnostic Name and Source	Affects Target	Severity	Persistence	Active Modes [Inactive Modes]	Criteria	Reset Level
Motor Current Overload - xB	Circuit	Immediate	Latch	Cprsr Energized	Compressor current exceeded overload time vs. trip characteristic. Must trip = 140% RLA, Must hold=125%, nominal trip 132.5% in 30 seconds	Local
Over Voltage	Chiller	Normal	NonLatch	Pre-Start and Any Ckt(s) Energized	Nom. trip: 60 seconds at greater than 112.5%, +/- 2.5%, Auto Reset at 110% or less for 10 continuous seconds.	Remote
Phase Loss - xy	Cprsr	Immediate	Latch	Start Sequence and Run modes	a) No current was sensed on one or two of the current transformer inputs while running or starting (See Non-latching Power Loss Diagnostic for all three phases lost while running). Must hold = 20% RLA. Must trip = 5% RLA. Time to trip shall be longer than guaranteed reset on Starter Module at a minimum, 3 seconds maximum. Actual design trip point is 10%. The actual design trip time is 2.64 seconds. b) If Phase reversal protection is enabled and current is not sensed on one or more current transformer inputs. Logic will detect and trip in a maximum of 0.3 seconds from compressor start.	Local
Phase Reversal - xy	Cprsr	Immediate	Latch	Compressor energized to transition command [All Other Times]	A phase reversal was detected on the incoming current. On a compressor start-up, the phase reversal logic must detect and trip in a maximum of .3 second from compressor start.	Local

Table 31. Diagnostics — Starter (continued)

Power Loss - xy	Cprsr	Immediate	NonLatch	All compressor running modes	The compressor had previously established currents while running and then <u>all three</u> phases of current were lost. Design: Less than 10% RLA, trip in 2.64 seconds. This diagnostic will preclude the Phase Loss Diagnostic and the Transition Complete Input Opened Diagnostic from being called out. To prevent this diagnostic from occurring with the intended disconnect of main power, the minimum time to trip must be greater than the guaranteed reset time of the Starter module. Note: This diagnostic prevents nuisance latching diagnostics due to a momentary power loss – It does not protect motor/compressor from uncontrolled power reapplication. See Momentary Power Loss Diagnostic for this protection. This diagnostic is not active during the start mode before the transition complete input is proven. Thus a random power loss during a start would result in either a “Starter Fault Type 3” or a “Starter Did Not Transition” latching diagnostic.	Remote
Severe Current Imbalance - xy	Circuit	Immediate	Latch	All Running Modes	A 30% Current Imbalance has been detected on one phase relative to the average of all 3 phases for 90 continuous seconds.	Local
Starter Comm Loss: Main Processor - xy	Cprsr	Immediate	Latch	All	The Starter module detected a continual loss of communication with the main processor for greater than the Communications Loss Time bound setpoint.	Local
Starter Contactor Interrupt Failure - xy	Chiller	Immediate and Special Action	Latch	Starter Contactor not Energized [Starter Contactor Energized]	Detected compressor currents greater than 10% RLA on any or all phases when the compressor was commanded off. Detection time shall be 5 second minimum and 10 seconds maximum. On detection and until the controller is manually reset: generate diagnostic, energize the appropriate alarm relay, continue to energize the Evap Pump Output, and continue to command the affected compressor off, fully unload the effected compressor and command a normal stop to all other compressors. For as long as current continues, perform liquid level, oil return, and fan control on the circuit effected. During contactor interrupt failure, circuit will not be confirmed off, so THR unit sequence should continue running. If THR turns off due to a diagnostic or lockout during contactor interrupt failure, the circuit reverts to air-cooled condenser fan control within 1 second.	Local
Starter Did Not Transition - xy	Cprsr	Immediate	Latch	On the first check after transition	The Starter Module did not receive a transition complete signal in the designated time from its command to transition. The Must Hold time from the Starter Module transition command is 1 second. The Must Trip time from the transition command is 6 seconds. Actual design is 2.5 seconds. This diagnostic is active only for Y-Delta, Auto-Transformer, Primary Reactor, and X-Line Starters.	Local
Starter Dry Run Test - xy	Cprsr	Immediate	Latch	Starter Dry Run Mode	While in the Starter Dry Run Mode either 50 % Line Voltage was sensed at the Potential Transformers or 10 % RLA Current was sensed at the Current Transformers.	Local
Starter Failed to Arm/Start - xy	Cprsr	Immediate	Latch	All	Starter failed to arm or start within the allotted time (15 seconds).	Local
Starter Fault Type I - xy	Cprsr	Immediate	Latch	Starting - Y Delta Starters Only	This is a specific starter test where 1M(1K1) is closed first and a check is made to ensure that there are no currents detected by the CT's. If currents are detected when only 1M is closed first at start, then one of the other contactors is shorted.	Local

Diagnostics

Table 31. Diagnostics — Starter (continued)

Starter Fault Type II - xy	Cprsr	Immediate	Latch	Starting - All types of starters	a. This is a specific starter test where the Shorting Contactor (1K3) is individually energized and a check is made to ensure that there are no currents detected by the CT's. If current is detected when only S is energized at Start, then 1M is shorted. b. This test in a. above applies to all forms of starters (Note: It is understood that many starters do not connect to the Shorting Contactor.).	Local
Starter Fault Type III - xy	Cprsr	Immediate	Latch	Starting [Adaptive Frequency Starter Type]	As part of the normal start sequence to apply power to the compressor, the Shorting Contactor (1K3) and then the Main Contactor (1K1) were energized. 1.6 seconds later there were no currents detected by the CT's for the last 1.2 Seconds on all three phases. The test above applies to all forms of starters except Adaptive Frequency Drives.	Local
Starter Module Memory Error Type 1 - xy	Cprsr	Warning	Latch	All	Checksum on RAM copy of the Starter LLID configuration failed. Configuration recalled from EEPROM.	Local
Starter Module Memory Error Type 2 - xy	Cprsr	Immediate	Latch	All	Checksum on EEPROM copy of the Starter LLID configuration failed. Default configuration loaded into RAM and EEPROM.	Local
Transition Complete Input Opened - xy	Cprsr	Immediate	Latch	All Running Modes	The Transition Complete input was found to be shorted before the compressor was started. This is active for all electromechanical starters.	Local
Transition Complete Input Shorted - xy	Cprsr	Immediate	Latch	Pre-Start	The Transition Complete input was found to be shorted before the compressor was started. This is active for all electromechanical starters.	Local
Under Voltage	Chiller	Normal	NonLatch	Pre-Start and Any Ckt(s) Energized	Nom. trip: 60 seconds at less than 87.5%, +/- 2.8% at 200V +/- 1.8% at 575V, Auto Reset at 90% or greater for 10 continuous seconds.	Remote

Main Processor Diagnostics

Table 32. Diagnostics — main processor

Diagnostic Name	Affects Target	Severity	Persistence	Active Modes [Inactive Modes]	Criteria	Reset Level
AFD Comm Loss - xA	Cprsr	Immediate	NonLatch	All	Communication has been lost between the UC800 and the applicable AFD. Once triggered, this diagnostic will auto-reset after 10 continuous minutes of restored communication to the compressor. (Note: The timer only starts once communication to the compressor is restored, which the UC800 will detect. If a manual reset request occurs during the timer period, it shall reset the diagnostic and the 'auto-reset' function will then be bypassed.)	Local
AFD Failure to Arm or Start - xA	Cprsr	Immediate	Latch	Running	The AFD failed to start within the allotted time (1 min). Definition of the "starting" value is the running status of the AFD. Note: This is a Controller diagnostic, not one originating from the AFD.	

Table 32. Diagnostics — main processor (continued)

Diagnostic Name	Affects Target	Severity	Persistence	Active Modes [Inactive Modes]	Criteria	Reset Level
AFD Interrupt Failure - xA	Chiller	Immediate Shutdown and Special Action	Latch	AFD Intended to be OFF	Respective AFD is reporting that it is still running the compressor when the MP has commanded the drive/ compressor to be Off. This diagnostic is triggered if the AFD running status remains in running for more than 16 seconds after the MP initiates the OFF command. On detection and until the controller is manually reset: this diagnostic shall be active and the alarm relay shall be energized, the Evap Pump Output will be energized, the effected compressor will be continually commanded off, and be unloaded, while a normal stop shall be commanded to all other compressors. For as long as compressor operation continues, the MP shall continue oil return and fan control on the circuit affected. During AFD interrupt failure, circuit will not be confirmed off, so THR unit sequence should continue running. If THR turns off due to a diagnostic or lockout during AFD interrupt failure, the circuit reverts to air-cooled condenser fan control within 1 second.	Local
AFD Unexpected Shutdown - xA	Cprsr	Normal	NonLatch	Running	The AFD status reported back that it is stopped when the MP thinks it should be running and no AFD diagnostic exists. This diagnostic will be logged in the active buffer and then automatically cleared. This diagnostic could be caused by intermittent communication problems from the AFD to the MP or due to mis-binding. Note: This is a Controller diagnostic, not one originating from the AFD.	Local
Chiller Service Recommended	Chiller	Warning	Latch	Service Messages Enabled	Chiller service interval time has elapsed. Chiller service is recommended.	Remote
Compressor Discharge Refrigerant Temperature Sensor - xy	Cprsr	Immediate	Latch	All	Bad Sensor or LLID	Remote
Condenser Refrigerant Pressure Sensor	Circuit	Immediate	Latch	All	Bad Sensor or LLID	Remote
Emergency Stop Feedback Input	Chiller	Immediate	Latch	All	A. Emergency stop feedback input is open. An external interlock has tripped. Time to trip from input opening to unit stop shall be 0.1 to 1.0 seconds.	Local
Evap Water Pump 1 Svc Recommended	Chiller	Warning	Latch	Service Messages Enabled	Pump service recommended as service interval hours have elapsed.	Remote
Evaporator Approach Error	Circuit	Immediate	Latch	Respective circuit running	The Evaporator approach temperature for the respective circuit (ELWT – Evap Sat Temp Ckt x) is negative by more than 10°F for 1 minute continuously while the circuit / compressor is operating. Either the Evap Leaving Water Temp sensor or Evap Suction Rfgt Pressure Sensor Ckt x is in error.	Remote
Evaporator Diff Water Pressure Xdcr	Chiller	Warning	Latch	All	Bad Sensor or LLID a. Display invalid value b. Flow calculation shall be disabled. See Water_Flow_and_Tons_Sensing.doc specification for additional information	Remote
Evaporator Entering Water Pressure	Chiller	Warning	Latch	All	Bad Sensor or LLID a. Display invalid value b. Flow calculation shall be disabled. See Water_Flow_and_Tons_Sensing.doc specification for additional information	Remote

Table 32. Diagnostics — main processor (continued)

Diagnostic Name	Affects Target	Severity	Persistence	Active Modes [Inactive Modes]	Criteria	Reset Level
Evaporator Entering Water Temperature Sensor	Chiller	Normal	Latch	All	Bad Sensor or LLID. Note: Entering Water Temp Sensor is used in EXV pressure control as well as ice making so it must cause a unit shutdown even if ice or CHW reset is not installed.	Remote
Evaporator Leaving Water Pressure	Chiller	Warning	Latch	All	Bad Sensor or LLID a. Display invalid value b. Flow calculation shall be disabled. See Water_Flow_and_Tons_Sensing.doc specification for additional information	Remote
Evaporator Leaving Water Temperature Sensor	Chiller	Normal	Latch	All	Bad Sensor or LLID	Remote
Evaporator Pump 1 Starts Run Time Written	Chiller	Warning	NonLatch	All	Diagnostic is triggered when the Evap Pump 1 Starts Run Time is manually over written. Diagnostic automatically clears and is immediately placed into the Historic Diagnostic Log.	Local
Evaporator Refrigerant Pool Temperature Sensor Error	Circuit	Warning and Special Action	Latch	Ckt Energized [Ckt Not Energized]	<p>This diagnostic can be triggered in two ways. There is an ignore time of 2 minutes following circuit start-up for both criteria. The trip criteria is not evaluated until the ignore time passes.</p> <p>1.) The evaporator refrigerant pool temperature measurement is larger than the evaporator entering water temperature by more than 4°C (7.2°F) for 5 continuous minutes.</p> <p>2.) If the absolute value of the Actual Evap Pool Temp Correction CktX is greater than the 'Evap Pool Temp Diagnostic Threshold CktX' AND the absolute value of the Pool Temp Error is greater than the 'Evap Pool Temp Diagnostic Threshold CktX', the diagnostic will occur.</p> <p>Continue to display the pool temperature measurement if the diagnostic is active. If evaporator isolation valves are installed, revert to Evaporator Shell Refrigerant Saturated Temperature for freeze protection functions. If evaporator isolation valves are not installed, revert to Evaporator Saturated Temperature for freeze protection functions. Pool Temp Sensor may have failed due to incorrect installation, improper insulation, or an offset pool temperature measurement typically caused by moisture intrusion.</p>	Local
Evaporator Refrigerant Pool Temperature Sensor	Circuit	Warning and Special Action	Latch	All	Bad Sensor or LLID. Note: The Evap Pool Temp Sensors are used for evaporator freeze protection (running and non-running). Invalidate evaporator pool temperature sensor measurement if this diagnostic is active. If evaporator isolation valves are installed, revert to Evaporator Shell Refrigerant Saturated Temperature for freeze protection functions. If evaporator isolation valves are not installed, revert to Evaporator Saturated Temperature for freeze protection functions.	Remote
Evaporator Water Flow Lost	Chiller	Immediate	NonLatch	[All Stop Modes]	<p>A. The Evaporator water flow switch input was open for more than 6 contiguous seconds (or 20 seconds for thermal dispersion type flow switch).</p> <p>B. This diagnostic does not de-energize the evap pump output.</p> <p>C. 6 seconds of contiguous flow shall clear this diagnostic. (further review needed when implementing thermal dispersion for Pueblo)</p>	Remote

Table 32. Diagnostics — main processor (continued)

Diagnostic Name	Affects Target	Severity	Persistence	Active Modes [Inactive Modes]	Criteria	Reset Level
Evaporator Water Flow Overdue	Chiller	Normal	NonLatch	Unit in Stop Mode, or in Auto Mode and No Ckt (s) Energized [Any Ckt Energized]	Evaporator water flow was not proven within 20 minutes of the Evaporator water pump relay being energized in normal "Stop" to "Auto" transition. If the pump is overridden to "On" for certain diagnostics, the delay on diagnostic callout shall be only 255 seconds. The pump command status will not be effected by this diagnostic in either case.	Remote
Evaporator Water Pump Fault	Chiller	Immediate	NonLatch	All	For systems with a single variable-speed evaporator pump, an immediate shutdown shall be performed, see Evaporator_Water_Pump_Control.doc	Remote
Evaporator Water Pump Speed Feedback	Chiller	Warning	Latch	All	Bad Sensor or LLID	Remote
Excessive Condenser Pressure	Circuit	Immediate	Latch	All	The condenser pressure sensor of this circuit has detected a condensing pressure in excess of the design high side pressure as limited by the particular compressor type.	Remote
External Chilled Water Setpoint	Chiller	Warning	Latch	All	A. Function Not "Enabled": no diagnostics. B. "Enabled ": Out-Of-Range Low or Hi or bad LLID, set diagnostic, default CWS to next level of priority (e.g. Front Panel SetPoint).	Remote
External Demand Limit Setpoint	Chiller	Warning	Latch	All	A. Not "Enabled": no diagnostics. B. "Enabled ": Out-Of-Range Low or Hi or bad LLID, set diagnostic, default CLS to next level of priority (e.g. Front Panel SetPoint.)	Remote
Fan Inverter Fault	Circuit	Warning	NonLatch	All	A fault signal has been detected from at least one of the Variable Speed Inverter Drive Condenser Fans of Circuit 1 or 2 (including the right hand fan of the Shared Fan Module if present). Starting in build after 4/5/2023, the fault signal must be faulted for at least 150sec (adjustable) continuously before this diagnostic is triggered. No action is taken.	Remote
Free Cooling Dedicated Fan Inverter Fault	Free Cooling	Warning	NonLatch	All	A fault signal has been detected from at least one of the Free Cooling Dedicated Fan Variable Speed Inverter Drive. Starting in build after 4/5/2023, the fault signal must be faulted for at least 150sec (adjustable) continuously before this diagnostic is triggered. No action is taken.	Remote
Free Cooling Entering Water Temperature	Free Cooling	Normal	Latch	All	Bad Sensor or LLID.	Remote
High Compressor Refrigerant Discharge Temp - xy	Cprsr	Immediate	Latch	All [compressor run unload or compressor not running]	The compressor discharge temperature exceeded 199.4°F (without oil cooler) or 230°F (with oil cooler). This diagnostic will be suppressed during Stopping mode or after the compressor has stopped. Note: As part of the Compressor High Temperature Limit Mode (aka Minimum Capacity Limit), the compressor shall be forced loaded as the filtered discharge temperature reaches 190°F (without oil coolers), or 220°F (with oil coolers).	Remote
High Differential Refrigerant Pressure - xy	Cprsr	Normal	Latch	Cprsr Energized	GP2 Cprsr: The differential pressure for the respective circuit was above 275 Psid (1890 kPa) for 2 consecutive samples 5 seconds apart.	Remote



Diagnostics

Table 32. Diagnostics — main processor (continued)

Diagnostic Name	Affects Target	Severity	Persistence	Active Modes [Inactive Modes]	Criteria	Reset Level
High Evaporator Refrigerant Pressure	Chiller	Immediate	NonLatch	All	The evaporator refrigerant pressure of either circuit has risen above 190 psig. The evaporator water pump relay will be de-energized to stop the pump regardless of why the pump is running. The diagnostic will auto reset and the pump will return to normal control when all of the evaporator pressures fall below 185 psig. The primary purpose is to stop the evaporator water pump and its associated pump heat from causing refrigerant side pressures, close to the evaporator relief valve setting, when the chiller is not running, such as could occur with Evap Water Flow Overdue or Evaporator Water Flow Loss Diagnostics.	Remote
High Evaporator Water Temperature	Chiller	Warning and Special Action	NonLatch	Only effective if either 1) Evap Wtr Flow Overdue, 2) Evap Wtr Flow Loss, or 3) Low Evap Rfgt Temp, Unit Off, diagnostic is active.	Either the leaving or the entering water temperature exceeded the high evap water temp limit (TU service menu settable –default 105°F (65.55°C), range 80°F (26.67°C)-120°F (48.9°C) for 15 continuous seconds. The evaporator water pump relay will be de-energized to stop the pump but only if it is running due one of the diagnostics listed on the left. The diagnostic will auto reset and the pump will return to normal control when both the entering and leaving temperatures fall 5°F below the trip setting. The primary purpose is to stop the evaporator water pump and its associated pump heat from causing excessive waterside temperatures and waterside pressures when the chiller is not running but the evap pump is on due to either Evap Water Flow Overdue, Evaporator Water Flow Loss, or Low Evap Temp – Unit Off Diagnostics. This diagnostic will not auto clear solely due to the clearing of the enabling diagnostic.	Remote
High Motor Winding Temperature - xA	Cprsr	Immediate	Latch	All	The respective compressor's motor winding thermostat is detected to be open. The compressor shall stop within 5 seconds of this diagnostic. For GP4 with triple RTD temperature sensors, a temperature greater than 265°F will generate this diagnostic.	Local
High Pressure Cutout - xy	Cprsr	Immediate	Latch	All	A high pressure cutout was detected; trip at 315 ± 5 PSIG. See 'AFD High Pressure Cutout - xy' diagnostic for AFD equivalent. This is only applicable to the Electro-Mechanical starter (i.e. GP2/GP2.5 Fixed Speed)	Local
High Refrigerant Pressure Ratio - xy	Cprsr	Immediate	Latch	Cprsr Energized	The pressure ratio for the respective circuit exceeded 12.3 for 1 contiguous minute while any compressor is running or in service pumpdown. This pressure ratio is a fundamental limitation of the HiVi compressor. The pressure ratio is defined as Pcond (abs)/Pevap(abs).	Remote
Inverted Evaporator Water Temperature	Chiller	Warning/Normal	NonLatch/Latch	Any Ckt Energized [No Ckts Energized]	*Function: Not Enabled (Default): diagnostic is Non-Latching and Warning. Enabled: diagnostic is Latching and Normal Shutdown. The entering evaporator water temp fell below the leaving evaporator water temp by more than 2°F for 180 °F-sec, minimum trip time 30 seconds. Diagnostic will auto clear if the leaving water temp – entering water temp < 2F. It can warn of improper flow direction through the evaporator, misbound water temperature sensors, improper sensor installation, partially failed sensors, or other system problems. Note that either entering or leaving water temp sensor or the water system could be at fault.	Remote

Table 32. Diagnostics — main processor (continued)

Diagnostic Name	Affects Target	Severity	Persistence	Active Modes [Inactive Modes]	Criteria	Reset Level
Liquid Line Pressure Sensor	Circuit	Normal	Latch	All	Bad Sensor or LLID. Note: This is the subcooled liquid line temp sensor.	Remote
Liquid Line Temperature Sensor	Circuit	Normal	Latch	All	Bad Sensor or LLID. Note: This is the subcooled liquid line temp sensor.	Remote
Loss of Oil for Compressor (Running)	Circuit	Immediate	Latch	Starter Contactor Energized	In running modes, Oil Loss Level Sensor detects lack of oil in the oil sump feeding the compressor (distinguishing a liquid flow from a vapor flow).	Local
Loss of Oil for Compressor (Stopped)	Circuit	Immediate Shutdown and Special Action	Latch	Compressor Pre-Start [all other modes]	In running modes, Oil Loss Level Sensor detects lack of oil in the oil sump feeding the compressor (distinguishing a liquid flow from a vapor flow).	Local
Low Differential Refrigerant Pressure - xy	Cprsr	Immediate	Latch	Cprsr Energized	For start-up, please refer to oil flow protection spec. For running, the system differential pressure for the respective circuit was below the greater of 25 psid (240.5 kPa) or the pressure ratio listed in the table in GP2 Compressor Type FSpec while the compressor is running for a period of time dependent on the deficit (15 sec ignore time from circuit start) – refer to the Oil Flow Protection specification for the time to trip function.	Remote
Low Discharge Superheat - xy	Cprsr	Normal	Latch	Any Running Mode	While Running Normally, the Compressor Discharge Superheat CprsrXY was less than the Low Disch Superheat Trip Setpt CprsrXY for more than (650* Low Discharge Superheat Setpoint) degree F seconds, for GP2 or more than (542* Low Discharge Superheat Setpoint) degree F seconds, for GP4. At circuit start-up, the Discharge Superheat will be ignored for 5 minutes.	Remote
Low Evaporator Entering Water Pressure	Chiller	Normal	Latch	All	Evaporator Entering Water Pressure fell below the Low Evaporator Water Pressure Cutout for more than 30 seconds.	Remote
Low Evaporator Leaving Water Pressure	Chiller	Normal	Latch	All	Evaporator Leaving Water Pressure fell below the Low Evaporator Water Pressure Cutout for more than 30 seconds.	Remote
Low Evaporator Refrigerant Temperature Circuit 1: Unit Off	Chiller	Special Action	NonLatch	Unit in Stop Mode, or in Auto Mode and No Ckt(s) Energized [Any Ckt Energized]	The respective circuit's LERTC Integral was seen to be > 0 while the chiller is in the Stop mode, or in Auto mode with no compressors running for at least one minute. The LERTC integral is increased if the Evap Refrigerant Pool Temp is below the value of the Low Evap Rfght Temp Cutout + 2°F. Energize Evap Water Pump and Off-Cycle Freeze Avoidance Request Relay until diagnostic auto resets, then return to normal evap pump control and de-energize the Freeze Avoidance Request. Automatic reset occurs when the respective Evap Rfght Pool Temp rises 4°F(1.1°C) above the LERTC cutout setting for 1 minute and the Chiller Off LERTC Integral = 0.. This diagnostic even while active, does not prevent operation of either circuit.	Remote
Low Evaporator Refrigerant Temperature Circuit 2: Unit Off	Chiller	Special Action	NonLatch	Unit in Stop Mode, or in Auto Mode and No Ckt(s) Energized [Any Ckt Energized]	The respective circuit's LERTC Integral was seen to be > 0 while the chiller is in the Stop mode, or in Auto mode with no compressors running for at least one minute. The LERTC integral is increased if the Evap Refrigerant Pool Temp is below the value of the Low Evap Rfght Temp Cutout + 2°F. Energize Evap Water Pump and Off-Cycle Freeze Avoidance Request Relay until diagnostic auto resets, then return to normal evap pump control and de-energize the Freeze Avoidance Request. Automatic reset occurs when the respective Evap Rfght Pool Temp rises 4°F(1.1°C) above the LERTC cutout setting for 1 minute and the Chiller Off LERTC Integral = 0.. This diagnostic even while active, does not prevent operation of either circuit.	Remote

Table 32. Diagnostics — main processor (continued)

Diagnostic Name	Affects Target	Severity	Persistence	Active Modes [Inactive Modes]	Criteria	Reset Level
Low Evaporator Water Flow	Chiller	Warning	NonLatch	Chiller Auto, manual water pump and All Running Modes	a. The evap. water flow measurement option was installed and the flow dropped to or below the Evaporator Low Water Flow Warning Setpoint. This diagnostic shall be Auto Reset when flow is (0.1 gpm/ton * NTON) above the adjustable trippoint or when the Evaporator water pump is turned off. b. See Water_Flow_and_Tons_Sensing.doc specification for additional information.	Remote
Low Evaporator Water Temperature (Unit Off)	Chiller	Special Action	NonLatch	Unit in Stop Mode, or in Auto Mode and No Ckt(s) Energized [Any Ckt Energized]	Either the entering or leaving evaporator water temp fell below the leaving water temp cutout setting for 30 degree F-seconds while the Chiller is in the Stop mode, or in Auto mode with no compressors running. Energize Freeze Avoidance Request Relay and Evap Water Pump Relay until diagnostic auto resets, then de-energize the Freeze Avoidance Request Relay and return to normal evap pump control. Automatic reset occurs when both temps rise 2°F (1.1°C) above the cutout setting for 5 minutes, or either circuit starts. This diagnostic even while active, does not prevent operation of either circuit.	Remote
Low Evaporator Water Temperature (Unit On)	Chiller	Immediate Shutdown and Special Action	NonLatch	Any Ckt[s] Energized [No Ckt(s) Energized]	The evaporator entering or leaving water temperature fell below the cutout setpoint for 30 degree F Seconds while the compressor was running. Automatic reset occurs when both of the temperature rises 2°F(1.1°C) above the cutout setting for 2 minutes. This diagnostic shall not de-energize the Evaporator Water Pump Output.	Remote
Low Oil Flow - xy	Cprsr	Immediate	Latch	Cprsr Energized and Delta P above 15 Psid	The intermediate oil pressure sensor for this compressor was out of the acceptable pressure range for 15 seconds, while the Delta Pressure was greater than 15 Psid. See Oil Flow Protection	Local
Low Refrigerant Temperature	Circuit	Immediate	Latch	All Ckt Running Modes	The warmer of either the either the Evaporator Refrigerant Pool Temperature or Active Rfgt Sat Temp for the respective circuit dropped below the Low Refrigerant Temperature Cutout Setpoint for 2250°F-sec (12°F-sec max rate for early circuit start-up period) while the circuit was running. The minimum LRTC setpoint is -5°F the point at which oil separates from the refrigerant. The integral is held nonvolatile though power down, is continuously calculated, and can decay or build during the circuit off cycle as conditions warrant.	Remote
Low Suction Refrigerant Pressure - xy	Cprsr	Immediate	Latch	Cprsr Prestart and Cprsr Energized	A. The Suction Pressure dropped below 10 Psia just prior to compressor start (after EXV preposition). (compressor is the lead compressor in circuit) B. During Early start-up Period: the Suction Pressure fell below a pressure equal to Condenser Pressure + 8 but as limited to not less than 6 or greater than 10 psia. C. After Early start-up Period expires: The Suction Pressure fell below 16 Psia.	Local
Mfr Maintenance Recommended - xy	Cprsr	Warning	Latch	Service Messages Enabled	Compressor service recommended as service interval hours have elapsed.	Remote
Motor Winding Temperature Sensor - xA	Cprsr	Warning(default) or Normal	Latch	All	Bad Sensor or LLID. See High Motor Winding Temperature Protection functional spec for other key details related to setting and the effects of the setting on the Severity.	Remote
MP: Invalid Configuration	Platform	Warning	Latch	All	MP has an invalid configuration based on the current software installed. The unit will not be allowed to run until a valid configuration is saved.	Remote

Table 32. Diagnostics — main processor (continued)

Diagnostic Name	Affects Target	Severity	Persistence	Active Modes [Inactive Modes]	Criteria	Reset Level
MP: Reset Has Occurred	Platform	Warning	NonLatch	All	The main processor has successfully come out of a reset and built its application. A reset may have been due to a power up, installing new software or configuration. This diagnostic is immediately and automatically cleared and thus can only be seen in the Historic Diagnostic List in Tracer TU.	Remote
No Differential Refrigerant Pressure - xy	Cprsr	Immediate	'A' cprsr: Auto Reset on timer – Latch if 3 instances in 30 minutes 'B' cprsr: Latch	Compressor running on Circuit	The system differential pressure was below 7.7 Psid (53 kPa) for 6 seconds after the 11 seconds ignore time relative to cprsr/circuit start-up had expired. 'A' GP4 compressors: Auto Reset on a 3 min timer, 2 retries allowed (beginning with build xxx when ACRC was introduced). 'B' GP2.5 compressors: always latching diagnostic ('no' Auto Reset).	Remote
Oil Flow Protection Fault - xy	Cprsr	Immediate	Latch	Starter Contactor Energized [all Stop modes]	The Intermediate Oil Pressure Sensor for this cprsr is reading a pressure either above its respective circuit's Condenser Pressure by 15 Psid or more, or below its respective compressor Suction Pressure 10 Psid or more for 30 seconds continuously.	Local
Oil Pressure Sensor - xy	Cprsr	Immediate	Latch	All	Bad Sensor or LLID	Remote
Oil Supply Temperature Sensor	Circuit	Normal	Latch	All	Bad Sensor or LLID	Remote
Outdoor Air Temperature Sensor	Chiller	Normal	Latch	All	Bad Sensor or LLID.	Remote
Pumpdown Terminated By Time	Circuit	Warning	Latch	Service Pumpdown	Service Pumpdown cycle for this circuit was terminated abnormally due to excessive time. Reference Service Pumpdown spec for maximum time allowed.	Local
Restart Inhibit Invoked - xy	Cprsr	Warning	NonLatch	All	When restart inhibit warning is enabled, the warning exists when unit has been inhibited from starting and is cleared when a start of a compressor is possible (Start-to-Start Timer expires)	Remote
Software Error 1001: Call Trane Service	Chiller	Immediate	Latch	All	A high level software watchdog has detected a condition in which there was a continuous 1 minute period of compressor operation, with neither Evaporator water flow nor a "contactor interrupt failure" diagnostic active. The presence of this software error message suggests an internal software problem has been detected. The events that led up to this failure, if known, should be recorded and transmitted to Trane Controls Engineering.	Local
Software Error 1002: Call Trane Service	Chiller	Immediate	Latch	All	Reported if state chart misalignment in stopped or inactive state occurred while a compressor was seen to be operating and this condition lasted for at least 1 minute (cprsr operation due to Service Pumpdown or with Contactor Interrupt Failure diagnostic is excluded). The presence of this software error message suggests an internal software problem has been detected. The events that led up to this failure, if known, should be recorded and transmitted to Trane Controls Engineering.	Local
Software Error 1003: Call Trane Service	Chiller	Immediate	Latch	All	Reported if state chart misalignment occurred inferred from the Capacity Control, Circuit, or Compressor State Machines remaining in the Stopping state for more than 3 minutes. The presence of this software error message suggests an internal software problem has been detected. The events that led up to this failure, if known, should be recorded and transmitted to Trane Controls Engineering. NOTE: This diagnostic will only apply to GP2 compressors with starter module.	Local



Diagnostics

Table 32. Diagnostics — main processor (continued)

Diagnostic Name	Affects Target	Severity	Persistence	Active Modes [Inactive Modes]	Criteria	Reset Level
Starts/Hours Modified - xy	Cprsr	Warning	NonLatch	All	The current value for the cumulative starts and or hours for the given compressor have been modified by a write override from TU in any running mode. The diagnostic will only appear in the Historic Alarms list.	Remote
Suction Refrigerant Pressure Sensor - xy	Cprsr	Immediate	Latch	All	Bad Sensor or LLID	Remote
Unexpected Starter Shutdown - xy	Cprsr	Normal	NonLatch	All Cprsr Running modes, Starting, Running and Preparing to Shutdown	The Starter module status reported back that it is stopped when the MP thinks it should be running and no Starter diagnostic exist. This diagnostic will be logged in the active buffer and then automatically cleared. This diagnostic could be caused by intermittent communication problems from the Starter to the MP or due to mis-binding	Local
Very Low Evaporator Refrigerant Pressure - xy	Chiller	Immediate	Latch	All	The respective circuit's evaporator pressure dropped below 80% of the current Low Evap Refrigerant Press Cutout setting (see above) or 8 psia, whichever is less, regardless of the running state of the circuit's compressor. Note: Unlike previous products, even if the circuit associated with the suction pressure sensor is locked out, it will not defeat the protection afforded by this diagnostic.	Local
Write Command Failure Energy Meter X	Chiller	Warning	Latch	All	Loss of communication to the Energy Meter during write command process (Controller writes to Energy Meter). Or Energy Meter X's 'Command Status' returns value that is NOT equal to 0 or 3 (0: successful, 3: in Progress). <i>Note: This diagnostic is applied to Schneider energy meter only.</i>	Remote
Write Value Failure Energy Meter X	Chiller	Warning	Latch	All	The read back value is not equal the written value. It will be tripped after two retries of write failure. <i>Note: This diagnostic currently applies to Trane Enercept (Veris) energy meter only.</i>	Remote

Communication Diagnostics

Table 33. Diagnostics — communication

Diagnostic Name	Affects Target	Severity	Persistence	Active Modes [Inactive Modes]	Criteria	Reset Level
Comm Loss: Condenser Receiver Tank Valve	Circuit	Warning	Latch	All	Continual loss of communication between the MP and the Functional ID has occurred for a 30 second period.	Remote
Comm Loss: Condenser Refrigerant Pressure	Circuit	Immediate	Latch	All	Continual loss of communication between the MP and the Functional ID has occurred for a 30 second period.	Remote
Comm Loss: Electronic Expansion Valve 1	Circuit	Normal	Latch	All	Continual loss of communication between the MP and the EXV Step Status has occurred for a 30 second period, OR EXV Steps Maximum Position has not been received. If EXV Steps Maximum Position has not been received, MP will periodically request EXV Steps Maximum Position, since it is only transmitted upon request.	Remote

Table 33. Diagnostics — communication (continued)

Diagnostic Name	Affects Target	Severity	Persistence	Active Modes [Inactive Modes]	Criteria	Reset Level
Comm Loss: Electronic Expansion Valve 2	Circuit	Normal	Latch	All	Continual loss of communication between the MP and the EXV Step Status has occurred for a 30 second period, OR EXV Steps Maximum Position has not been received. If EXV Steps Maximum Position has not been received, MP will periodically request EXV Steps Maximum Position, since it is only transmitted upon request.	Remote
Comm Loss: Emergency Stop Feedback Input	Chiller	Normal	Latch	All	Continual loss of communication between the MP and the Functional ID has occurred for a 30 second period.	Remote
Comm Loss: Energy Meter X	Chiller	Warning	Latch	All	Continual loss of communication between the MP and the Power Meter has occurred for a 30 second period.	Remote
Comm Loss: Evaporator Entering Water Temperature	Chiller	Normal	Latch	All	Continual loss of communication between the MP and the Functional ID has occurred for a 30 second period. Note: Entering Water Temp Sensor is used in EXV pressure control as well as ice making & CHW reset, so it must cause a unit shutdown even if Ice or CHW reset is not installed.	Remote
Comm Loss: Evaporator Leaving Water Temperature	Chiller	Normal	Latch	All	Continual loss of communication between the MP and the Functional ID has occurred for a 30 second period.	Remote
Comm Loss: Evaporator Refrigerant Pool Temperature	Circuit	Warning/ Special Action	Latch	All	Continual loss of communication between the MP and the Functional ID has occurred for a 30 second period. Invalidate evaporator pool temperature sensor measurement if this diagnostic is active. If evaporator isolation valves are installed, revert to Evaporator Shell Refrigerant Saturated Temperature for freeze protection functions. If evaporator isolation valves are not installed, revert to Evaporator Saturated Temperature for freeze protection functions.	Remote
Comm Loss: Evaporator Water Flow Switch	Chiller	Immediate	Latch	All	Continual loss of communication between the MP and the Functional ID has occurred for a 30 second period.	Remote
Comm Loss: Evaporator Water Pump Relay	Chiller	Normal	Latch	All	Continual loss of communication between the MP and the Functional ID has occurred for a 30 second period.	Remote
Comm Loss: Ext Noise Reduction Request	Chiller	Warning	Latch	All	Continual loss of communication between the MP and the Functional ID has occurred for a 30 second period.	Remote
Comm Loss: External Auto/ Stop	Chiller	Normal	Latch	All	Continual loss of communication between the MP and the Functional ID has occurred for a 30 second period.	Remote
Comm Loss: External Chilled Water Setpoint	Chiller	Warning/ Special Action	Latch	All	Continual loss of communication between the MP and the Functional ID has occurred for a 30 second period. Chiller shall discontinue use of the External Chilled Water Setpoint source and revert to the next higher priority for setpoint arbitration	Remote
Comm Loss: External Ckt Lockout	Circuit	Warning/ Special Action	Latch	All	Continual loss of communication between the MP and the Functional ID has occurred for a 30 second period. MP will nonvolatile hold the lockout state (enabled or disabled) that was in effect at the time of comm loss.	Remote
Comm Loss: External Demand Limit Setpoint	Chiller	Warning/ Special Action	Latch	All	Continual loss of communication between the MP and the Functional ID has occurred for a 30 second period. Chiller shall discontinue use of the External Demand limit setpoint and revert to the next higher priority for Demand Limit setpoint arbitration.	Remote

Table 33. Diagnostics — communication (continued)

Diagnostic Name	Affects Target	Severity	Persistence	Active Modes [Inactive Modes]	Criteria	Reset Level
Comm Loss: External Ice Building Command	Chiller	Warning/ Special Action	Latch	All	Continual loss of communication between the MP and the Functional ID has occurred for a 30 second period. Chiller shall revert to normal (non-ice building) mode regardless of last state.	Remote
Comm Loss: Fan Inverter Fault	Circuit	Warning	Latch	All	Continual loss of communication between the MP and the Functional ID has occurred for a 30 second period.	Remote
Comm Loss: Fan Inverter Speed Command	Circuit	Normal	Latch	All	Continual loss of communication between the MP and the Functional ID has occurred for a 30 second period.	Remote
Comm Loss: Fan Inverter Speed Command, Shared Circuit 1 & 2	Circuit	Warning	Latch	All	Continual loss of communication between the MP and the Functional ID has occurred for a 15-30 second period. This is a warning, as it is conceivable that the circuit may run without the center shared fan deck working if there are many other coils/fans on the circuits.	Remote
Comm Loss: Free Cooling Bypass Valve	Free Cooling	Normal	Latch	All	Continual loss of communication between the MP and the Functional ID has occurred for a 30 second period.	Remote
Comm Loss: Free Cooling Entering Water Temperature	Free Cooling	Normal	Latch	All	Continual loss of communication between the MP and the Functional ID has occurred for a 30 second period.	Remote
Comm Loss: Free Cooling Valve	Free Cooling	Normal	Latch	All	Continual loss of communication between the MP and the Functional ID has occurred for a 30 second period.	Remote
Comm Loss: High Pressure Cutout Switch - xy	Cprsr	Normal	Latch	All	Continual loss of communication between the MP and the Functional ID has occurred for a 30 second period.	Remote
Comm Loss: Liquid Line Pressure	Circuit	Normal	Latch	All	Continual loss of communication between the MP and the Functional ID has occurred for a 30 second period.	Remote
Comm Loss: Liquid Line Temperature	Circuit	Normal	Latch	All	Continual loss of communication between the MP and the Functional ID has occurred for a 30 second period. Note: The Subcooled Liquid Line Temperature Sensors are used for determination of charge and accurate tonnage predictions	Remote
Comm Loss: Motor Winding Temperature 1, CprsrXY	Cprsr	Normal	Latch	All	Continual loss of communication between the MP and the Functional ID has occurred for a 30 second period.	Remote
Comm Loss: Motor Winding Temperature 2, CprsrXY	Cprsr	Normal	Latch	All	Continual loss of communication between the MP and the Functional ID has occurred for a 30 second period.	Remote
Comm Loss: Oil Loss Level Sensor Input	Circuit	Normal	Latch	All	Continual loss of communication between the MP and the Functional ID has occurred for a 30 second period.	Remote
Comm Loss: Oil Pressure - xy	Cprsr	Immediate	Latch	All	Continual loss of communication between the MP and the Functional ID has occurred for a 30 second period.	Remote
Comm Loss: Oil Return Line Solenoid Valve - xB	Cprsr	Normal	Latch	All	Continual loss of communication between the MP and the Functional ID has occurred for a 30 second period.	Remote

Table 33. Diagnostics — communication (continued)

Diagnostic Name	Affects Target	Severity	Persistence	Active Modes [Inactive Modes]	Criteria	Reset Level
Comm Loss: Oil Return Valve - xy	Circuit	Normal	Latch	All	Continual loss of communication between the MP and the Functional ID has occurred for a 30 second period. <i>Design Note: this diagnostic is intended for the GP4 compressors only (Cprsr 1A and 2A). Some consideration was given to making this a circuit shutdown since without the valve, the GP4 oil return cannot work properly, and if the GP4 can't run, neither can its manifolded GP2 - but if the valve is open somewhere between its min and max, the circuit may be able to run reasonably well – and other diagnostics can protect against oil loss, or low disch SH, or lack of drive cooling that may result.</i>	Remote
Comm Loss: Oil Supply Temperature	Circuit	Normal	Latch	All	Continual loss of communication between the MP and the Functional ID has occurred for a 30 second period.	Remote
Comm Loss: Outdoor Air Temperature	Chiller	Normal	Latch	All	Continual loss of communication between the MP and the Functional ID has occurred for a 30 second period.	Remote
Comm Loss: Programmable Relay Board 1	Chiller	Warning	Latch	All	Continual loss of communication between the MP and the Functional ID has occurred for a 30 second period.	Remote
Comm Loss: Programmable Relay Board 2	Chiller	Warning	Latch	All	Continual loss of communication between the MP and the Functional ID has occurred for a 30 second period.	Remote
Comm Loss: Slide Valve Load - xy	Cprsr	Normal	Latch	All	Continual loss of communication between the MP and the Functional ID has occurred for a 30 second period.	Remote
Comm Loss: Slide Valve Unload - xy	Cprsr	Normal	Latch	All	Continual loss of communication between the MP and the Functional ID has occurred for a 30 second period.	Remote
Comm Loss: Starter xy	Cprsr	Immediate	Latch	All	Continual loss of communication between the MP and the Functional ID has occurred for a 30 second period.	Local
Comm Loss: Step Load - xy	Cprsr	Normal	Latch	All	Continual loss of communication between the MP and the Functional ID has occurred for a 30 second period.	Remote
Comm Loss: Suction Refrigerant Pressure - xy	Cprsr	Immediate	Latch	All [Ckt/Cprsr lock out]	Continual loss of communication between the MP and the Functional ID has occurred for a 30 second period.	Remote
Comm Loss: Variable Vi Valve - CprsrXY	Cprsr	Normal	Latch	All	Continual loss of communication between the MP and the Functional ID has occurred for a 30 second period.	Remote
Comm Loss: % RLA Indication Output(Vdc)	Chiller	Warning	Latch	All	Continual loss of communication between the MP and the Functional ID has occurred for a 30 second period.	Remote
Comm Loss: Auxiliary Setpoint Command	Chiller	Warning	Latch	All	Continual loss of communication between the MP and the Functional ID has occurred for a 30 second period.	Remote
Comm Loss: Compressor Discharge Refrigerant Temperature - xy	Cprsr	Normal	Latch	All	Continual loss of communication between the MP and the Functional ID has occurred for a 30 second period.	Remote
Comm Loss: Condenser Fan Enable	Circuit	Normal	Latch	All	Continual loss of communication between the MP and the Functional ID has occurred for a 30 second period.	Remote

Table 33. Diagnostics — communication (continued)

Diagnostic Name	Affects Target	Severity	Persistence	Active Modes [Inactive Modes]	Criteria	Reset Level
Comm Loss: Condenser Fan Enable, Shared Circuit 1 & 2	Circuit	Warning	Latch	All	Continual loss of communication between the MP and the Functional ID has occurred for a 30 second period. This is a warning, as it is conceivable that the circuit may run without the center shared fan deck working if there are many other coils/fans on the circuits.	Remote
Comm Loss: Evap Diff Water Pressure	Chiller	Warning	Latch	All	Continual loss of communication between the MP and the Functional ID has occurred for a 30 second period. Flow and tons calculation shall be disabled. Display invalid value.	Remote
Comm Loss: Evaporator Entering Water Pressure	Chiller	Warning	Latch	All	Continual loss of communication between the MP and the Functional ID has occurred for a 30 second period. Flow and tons calculation shall be disabled. Display invalid value.	Remote
Comm Loss: Evaporator Leaving Water Pressure	Chiller	Warning	Latch	All	Continual loss of communication between the MP and the Functional ID has occurred for a 30 second period. Flow and tons calculation shall be disabled. Display invalid value.	Remote
Comm Loss: Evaporator Oil Return Purge Valve - XY	Cprsr	Normal	Latch	All	Continual loss of communication between the MP and the Functional ID has occurred for a 30 second period.	Remote
Comm Loss: Evaporator Pump Fault Input	Chiller	Normal	Latch	All	Continual loss of communication between the MP and the Functional ID has occurred for a 30 second period.	Remote
Comm Loss: Evaporator Pump Inverter Running Status	Chiller	Warning	Latch	All	Continual loss of communication between the MP and the Functional ID has occurred for a 30 second period.	Remote
Comm Loss: Evaporator Pump Speed Command	Chiller	Normal	Latch	All	Continual loss of communication between the MP and the Functional ID has occurred for a 30 second period.	Remote
Comm Loss: Evaporator Pump Speed Feedback	Chiller	Warning	Latch	All	Continual loss of communication between the MP and the Functional ID has occurred for a 30 second period.	Remote
Comm Loss: Free Cooling Dedicated Fan Enable	Free Cooling	Normal	Latch	All	Continual loss of communication between the MP and the Functional ID has occurred for a 30 second period.	Remote
Comm Loss: Free Cooling Dedicated Fan Inverter Fault	Free Cooling	Warning	Latch	All	Continual loss of communication between the MP and the Functional ID has occurred for a 30 second period.	Remote
Comm Loss: Free Cooling Dedicated Fan Inverter Speed Command	Free Cooling	Normal	Latch	All	Continual loss of communication between the MP and the Functional ID has occurred for a 30 second period.	Remote
Comm Loss: Hot Gas Oil Return Valve - xy	Cprsr	Normal	Latch	All	Continual loss of communication between the MP and the Functional ID has occurred for a 30 second period.	Remote



Unit Wiring

The following table provides a list of electrical schematics, field wiring diagrams and connection diagrams. Wiring diagrams can be accessed via e-Library. A

laminated wiring diagram booklet is also shipped with each unit.

Table 34. Wiring diagrams — 150 to 330 ton units

Document Number		Description	
2311-5991	Sheet 1	Schematic Wiring	Device Designations, Locations, and Warning
	Sheet 2		Condenser Fan Locations
	Sheet 3		Unit Power Distribution
	Sheet 4		Compressor VFDs, Harmonic Filters, and Evaporator Pump Power Distribution
	Sheet 5		Circuit 1 Variable Speed Condenser Fans (default)
	Sheet 6		Circuit 2 Variable Speed Condenser Fans (default)
	Sheet 7		Extra Free Cooling Fans (optional)
	Sheet 8		Circuit 1 Fixed Speed condenser Fans (optional)
	Sheet 9		Circuit 2 and Split V Fixed Speed Condenser Fans (optional)
	Sheet 10		Compressor VFD Control and Options Enclosure Interface
	Sheet 11		Compressor Control
	Sheet 12		Refrigerant, Heater, and Common Panel Control
	Sheet 13		115 Vac 27 Vac CPTS, 24 Vdc Power Supplies, Flow Switch, and Oil Level Switches
	Sheet 14		Variable Speed Condenser Fan Control Refrigerant Circuit 1 and 2 (default)
	Sheet 15		Fixed Speed Condenser Fan Control Refrigerant Circuit 1 (optional)
	Sheet 16		Fixed Speed Condenser Fan Control Refrigerant Circuit 2 and Shared V (optional)
	Sheet 17		Free Cooling Bypass Actuators and Extra Free Cooling Fan Control
	Sheet 18		Evaporator Pump Package (optional)
	Sheet 19		Global Bus Connections
	Sheet 20		Symbio 800 Connections
	Sheet 21		Field Connections; 115 Vac/1 and 24 Vdc, Convenience Outlet, Evaporator Heaters, and I/O
2311-6454	Sheet 1	Field Wiring	Power and Communications Connections
	Sheet 2		Field Connections; 115Vac/1 and 24 Vdc, Convenience Outlet, Evaporator Heaters, and I/O
5732-5331		Panel Component Location	
5732-5333		Unit Component Location	



Unit Wiring

Table 35. Wiring diagrams — Units larger than 330 tons

Document Number		Description	
2311-5990	Sheet 1	Schematic Wiring	Device Designations and Descriptions
	Sheet 2		Device Locations, Notes, and Warning
	Sheet 3		Single Point and Circuit 1 Power Distribution
	Sheet 4		Compressor 1A VFD, Compressor 1B YD, and Harmonic Filter Power Distribution and Control
	Sheet 5		Circuit 1 Variable Speed Condenser Fans (12 or 14) (default)
	Sheet 6		Circuit 1 Fixed Speed Condenser Fans (12) (optional)
	Sheet 7		Circuit 1 Fixed Speed Condenser Fans (14) (optional)
	Sheet 8		Compressor 1A VFD Control and Options Enclosure Interface
	Sheet 9		Compressor 1A, Refrigerant Circuit 1, and Common Panel Control
	Sheet 10		Compressor 1B Wye Delta, Heater, and Refrigerant Circuit 1 Oil Separator Heater
	Sheet 11		Compressor 1B Solenoid Control and High Pressure Switch
	Sheet 12		115 Vac-27CPTS, 24Vdc Power Supplies, Flow Switch, and Oil Switch
	Sheet 13		Variable Speed Condenser Fan Control Refrigerant Circuit 1 (default)
	Sheet 14		Fixed Speed Condenser Fan Control Refrigerant Circuit 1 (optional)
	Sheet 15		Free Cooling Bypass Actuators
	Sheet 16		Power Distribution Circuit 2
	Sheet 17		Compressor 2A VFD, Compressor 2B YD, and Harmonic Filter Power Distribution and Control
	Sheet 18		Circuit 2 Variable Speed Condenser Fans (6) (default)
	Sheet 19		Circuit 2 Variable Speed Condenser Fans (8 or 10) (default)
	Sheet 20		Circuit 2 Fixed Speed Condenser Fans (6 or 8) (optional)
	Sheet 21		Circuit 2 Fixed Speed Condenser Fans (10) (optional)
	Sheet 22		Compressor 2A VFD Control and Options Enclosure Interface
	Sheet 23		Compressor 2A, Refrigerant Circuit 2, and Common Panel Control
	Sheet 24		Compressor 2B Wye Delta, Heater, and Refrigerant Circuit 2 Oil Separator Heater
	Sheet 25		Compressor 2B Solenoid Control and High Pressure Switch
	Sheet 26		115 Vac-27 Vac CPTS, 24Vdc Power Supplies, and Oil Switch
	Sheet 27		Variable Speed Condenser Fan Control Refrigerant Circuit 2(default)
	Sheet 28		Fixed Speed Condenser Fan Control Refrigerant Circuit 2 (optional)
	Sheet 29		Global Bus Connections
	Sheet 30		Symbio 800 Connections
	Sheet 31		Field Connections; 115Vac/1 and 24 Vdc. Convenience Outlet, Evaporator Heaters, and (/)
2311-6453	Sheet 1	Field Wiring	Power Connections
	Sheet 2		Communication Connections
	Sheet 3		Field Connections; 115Vac/1 and 24 Vdc. Convenience Outlet, Evaporator Heaters, and I/O

Table 35. Wiring diagrams — Units larger than 330 tons (continued)

Document Number		Description	
5732-5332		Panel Component Location	
5732-5334		Unit Component Location	



Log and Check Sheets

The following are included for use as appropriate, for installation completion verification before Trane start-up is scheduled, and for reference during the Trane start-up. Where the log or check sheet also exists outside of this publication as standalone literature, the literature order number is also listed.

- *Installation Completion and Request for Trane Service, Ascend™ Air-Cooled Chiller Model ACR Series C Form (AC-ADF005*-EN)*
- Operator Log

Ascend™ Model ACR Series C Installation Completion Check Sheet and Request for Trane Service

Important: A copy of this completed form must be submitted to the Trane service agency that will be responsible for the start-up of the chiller. Start-up will NOT proceed unless applicable items listed in this form have been satisfactorily completed.

To: _____

Trane Service Office: _____

S.O. Number: _____

Serial Numbers: _____

Job/Project Name: _____

Address: _____

The following items are being installed and will be completed by: _____

Important: Start-up must be performed by Trane or an agent of Trane specifically authorized to perform start-up and warranty of Trane® products. Contractor shall provide Trane (or an agent of Trane specifically authorized to perform start-up) with notice of the scheduled start-up at least two weeks prior to the scheduled start-up.

Important: Chiller heaters must be energized a minimum of 24 hours prior to start-up. Chiller should have power applied for this amount of time before Trane Service arrives for start-up.

Check boxes if the task is complete or if the answer is "yes".

1. Chiller

- Installation meets foundation requirements.

- In place and piped.
- Isolation pads or elastomeric pads installed (optional).
- For units with InvisiSound™ Ultimate Option (model number digit 13 = E), compressor mounting bolts have been removed.

2. Refrigerant Pressure Check

- PRIOR to water being pumped into system, use gauges to verify positive pressure in the evaporator and condenser. Lack of pressure could indicate a system leak. When charging in the factory, approximately 95% of the refrigerant charge is isolated in the evaporator, and the other 5% is contained in the condenser and compressor. If no pressure is present, contact local Trane service.

Note: Verification must be done by gauges. Do NOT rely only on values from unit controls.

3. Piping

- Water piping flushed before making final connections to the system
 - Chilled water piping connected to:
 - Evaporator
 - Pumps
 - Flow switch or flow proving device installed (if not factory provided)
 - Strainer installed and cleaned
- Water supply connected to filling system
- Does unit have freeze inhibitor? If unit has freeze inhibitor:
 - Verify type and concentration is correct per unit submittal
 - Calculate and record freeze point of the solution: _____
- Systems filled
- Pumps run, air bled from system
- Relief valve ventilation piping installed (if applicable)

4. Flow balancing valves installed

- Leaving chilled water

5. Gauges, thermometers, and air vents

- Installed on both sides of evaporator

6. Electrical

- Wire size per submittal and NEC table 310.15(B)(16)
- Full power available
- Interconnecting wiring, starter to panel (as required)

- External interlocks (flow switch, pumps auxiliary, etc.)
- Chilled water pump (connected and tested)
- 115 Vac power available for service tools
- All controls installed and connected
- Power distribution grounding type identified:
 - Solidly Grounded (Center Ground Wye)
 - or-
 - Non-Solidly Grounded (Any Delta, High Impedance Ground, or Ungrounded Wye)

Important: When the unit is connected to a corner-grounded supply, completely remove ground wire(s) 1004B/2004B from surge arrestor components 1FA1 and 2FA1 on subpanel(s). See schematic for details.

7. Testing

- Dry nitrogen available for pressure testing
- Trace gas amounts of refrigerant available for leak testing, if necessary

8. Refrigerant on job site (if nitrogen charge option, model number digit 16 = F, is chosen)
9. Systems can be operated under load conditions
10. Heaters

- If unit was factory charged (model number digit 16 = E), energize heaters for 24 hours prior to start-up.

Important: Chiller heaters must be energized a minimum of 24 hours prior to start-up. Chiller should have power applied for this amount of time before Trane Service arrives for start-up.

- If unit has nitrogen charge (model number digit 16 = F), contact Trane Service for unit charging prior to start-up.

Important: Do NOT apply shore/service power to unit with nitrogen charge. Shore/service power will drive EXV valves, inhibiting ability to adequately Vac and charge unit.

11. Owner Awareness

- Does the owner have a copy of the MSDS for refrigerant?

Note: Additional time required to properly complete the start-up and commissioning, due to any incompleteness of the installation, will be invoiced at prevailing rates.

This is to certify that the Trane® equipment has been properly and completely installed, and that the applicable items listed above have been satisfactorily completed.

Checklist completed by: _____

Signed: _____

Date: _____

In accordance with your quotation and our purchase order number _____, we will therefore require the presence of Trane service on this site, for the purpose of start-up and commissioning, by _____ (date).

Note: Minimum two-week advance notification is required to allow scheduling of the chiller start-up.

Additional Comments/Instructions:

Note: A copy of this completed form must be submitted to the Trane Service Office that will be responsible for start-up of chiller.

Operator Log

Ascend™ ACR Chiller with Symbio™ 800 Controller - AdaptiView™ Reports - Log Sheet				
	Start	15 minutes	30 minutes	1 hour
EVAPORATOR				
Active Chilled Water Setpoint				
Entering Water Temperature				
Leaving Water Temperature				
Evaporator Water Flow Status				



Log and Check Sheets

Ascend™ ACR Chiller with Symbio™ 800 Controller - AdaptiView™ Reports - Log Sheet				
	Start	15 minutes	30 minutes	1 hour
Ckt 1				
Saturated Refrigerant Temperature (°F)				
Refrigerant Pressure (psia)				
Approach Temperature (°F)				
EXV % Open				
Ckt 2				
Saturated Refrigerant Temperature (°F)				
Refrigerant Pressure (psia)				
Approach Temperature (°F)				
EXV % Open				
CONDENSER				
Outdoor Air Temperature				
Ckt 1				
Air Flow %				
Saturated Refrigerant Temperature (°F)				
Refrigerant Pressure (psia)				
Ckt 2				
Air Flow %				
Saturated Refrigerant Temperature (°F)				
Refrigerant Pressure (psia)				
COMPRESSOR 1A				
Running Status				
Starts				
Running Time (Hr:Min)				
Oil Pressure (psia)				
COMPRESSOR 1B				
Running Status				
Starts				
Running Time (Hr:Min)				
Oil Pressure (psia)				
MOTOR 1A				
Active Demand Limit Setpoint				
Average Motor Current (%)				
Percent Speed				
AFD Average Input Voltage (Volts)				
AFD Input Power (kW)				
AFD Output Power (kW)				
AFD Speed (rpm)				



Log and Check Sheets

Ascend™ ACR Chiller with Symbio™ 800 Controller - AdaptiView™ Reports - Log Sheet				
	Start	15 minutes	30 minutes	1 hour
MOTOR 1B				
Average Motor Current (%)				
COMPRESSOR 2A				
Running Status				
Starts				
Running Time (Hr:Min)				
Oil Pressure (psia)				
COMPRESSOR 2B				
Running Status				
Starts				
Running Time (Hr:Min)				
Oil Pressure (psia)				
MOTOR 2A				
Average Motor Current (%)				
Percent Speed				
AFD Average Input Voltage (Volts)				
AFD Input Power (kW)				
AFD Output Power (kW)				
AFD Speed (rpm)				
MOTOR 1B				
Average Motor Current (%)				

Date:
Technician:
Owner:

Trane - by Trane Technologies (NYSE: TT), a global innovator - creates comfortable, energy efficient indoor environments for commercial and residential applications. For more information, please visit trane.com or tranetechnologies.com.

Trane has a policy of continuous product and product data improvements and reserves the right to change design and specifications without notice. We are committed to using environmentally conscious print practices.

AC-SVX003F-EN 10 Jul 2026
Supersedes AC-SVX003E-EN (February 2026)

©2026 Trane