



Product Catalog

Trane Rental Services

Temporary Cooling Pumps



October 2024

TEMP-PRC003A-EN

TRANE
TECHNOLOGIES™



Introduction

Read this manual thoroughly before operating or servicing this unit.

Copyright

This document and the information in it are the property of Trane, and may not be used or reproduced in whole or in part without written permission. Trane reserves the right to revise this publication at any time, and to make changes to its content without obligation to notify any person of such revision or change.

Trademarks

All trademarks referenced in this document are the trademarks of their respective owners.

Revision History

Document updated to reflect Service Offering number.



Table of Contents

General Information.....	4
Model Number Description	5
Application Considerations	6
Two Forms of Overcurrent Protection	6
Split Coupled Inline Vertical (F2) Model Pump Features	6
Parallel and Series Pumps	8
Armstrong	9
10 Horsepower	9
15 Horsepower	13
25 Horsepower	17
30 Horsepower	19
40 Horsepower	27
50 Horsepower	31
60 Horsepower	36
100 Horsepower	42
125 Horsepower	44
Integral Pumps	51
25 Ton CGAM	51
40 to 60 Ton CGAM	53
80 to 120 Ton CGAM	55
155/170/200 Ton RTAC (F0).....	57
155/170/200 Ton RTAC (F2–F3)	58
200 Ton ACSA (F0–F1)/200 Ton AXCA (F1)	59
250 Ton RTAC (F0)	61
250 Ton RTAC (F2–F3)	62
400 Ton RTAA and 300/400 Ton RTAC (F0).....	63
300/400 Ton RTAC (F2–F3)	65
500 Ton RTAC (F0)	66
500 Ton RTAC (F2–F4)	67



General Information

Trane Rental Services (TRS) offers a wide variety of pumps to lease for temporary cooling needs. The pumps used are designed not to exceed 150 psi due to flexible hose and chiller limitations. Care should be taken to not exceed 150 psi in any application using Trane Rental Services equipment without prior approval.

Stand-alone pumps should not exceed the maximum 175 psi operating pressure and 200°F temperature. Consult with TRS engineering if the application has higher operating pressures greater than 150 psi.

System pump(s) are typically designed for a specific head pressure and flow rate. It is desirable to use the system pump(s) if possible and use TRS temporary pump(s) as booster pump(s). All pumps come complete on forklift compatible bases, with fused disconnects, and inlet and discharge valves. These pumps do not contain variable frequency drives (VFD). Certain pumps may be fitted with a VFD. Contact TRS engineering for assistance on this topic. Every effort has been taken to have the particular horsepower pump cover a wide range of operating conditions as temporary cooling jobs often present unknowns. It is crucial the temporary cooling solution designer take precautions to ensure they understand the pumping needs of the job so the correct pump is initially ordered.

The following information is provided as a quick reference for each of Trane Rental Services pumps to aid in determining which is needed to meet the job requirements. If the application is sensitive, call TRS engineering for assistance in selecting a specific pumping system. Net Positive Suction Head Required (NPSHr) performance is available for Armstrong pump models upon request from TRS engineering.

Note: All pumps should be installed per the National Electric Code (NEC) and/or applicable local codes.



Model Number Description

Digit 1, 2, 3— Trane Rental Services Pump

None

Digit 4 — Vendor

C = Armstrong

Digit 5, 6, 7, 8 — Horsepower

0010 = 10 HP
0015 = 15 HP
0025 = 25 HP
0030 = 30 HP
0040 = 40 HP
0060 = 60 HP
0125 = 125 HP

Digit 9 — Voltage

F = 460/60/3

Digit 10 — Pump Family Type

0 = Close Coupled
1 = Horizontal Split Case
2 = Split Coupled Inline Vertical

Digit 11, 12— Incremental Designator

AA = Incremental Designator



Application Considerations

Newer Armstrong pump sizes 10 HP through 30 HP have across the line starters and 40 HP through 125 HP typically have Wye-Delta starters, but this is not standard for all Trane Rental pump models. TRS Engineering recommends using Split Coupled Inline Vertical (F2) pump models that have premium efficiency motors for applications that require VFDs.

All stand-alone Close Coupled (F0) and Horizontal Split Case (F1) pumps ship to each jobsite with 50 foot long whips with pig-tail connections, and the cable sizes vary depending on what capacity size pump you are using. The pigtail sizing chart below shows the minimum cable sizes recommended by Trane Rental Services to be used with each horse power pump size.

All Split Coupled Inline Vertical (F2) pump models ship with series 16 cam-type connections only and do not come with their cable. Rental cable can be provided for these pumps, refer to CHS-PRB005*-EN for more information on the rental cable.

Table 1. Pig-tail cable size chart

Pump	MCA	Cable Size
		Type-W
10 hp	18	12 awg
15 hp	25	12 awg
25 to 30 hp	43	8 awg
40 hp	65	6 awg
50 hp	75	6 awg
60 hp	90	4 awg
100 hp	144	1 awg
125 hp	184	1/0 awg

Two Forms of Overcurrent Protection

Each TRS pump model has overload relays that are provided for pump motor overcurrent protection in conjunction with circuit breakers or fused disconnects depending on the series of pump model. Standalone Closed Coupled (F0) and Horizontal Split Case (F1) pump models will either have fused disconnects or circuit breakers, and all Split Coupled Vertical Inline (F2) pump models will have circuit breakers. Integral chiller pumps utilize the chiller's circuit breaker along with an overload relay for over current protection.

Split Coupled Inline Vertical (F2) Model Pump Features

- Totally Enclosed Fan Cooled (TEFC) premium efficient motors
- Cam-lock supply voltage cable connections
- Differential pressure gauges
- Circuit breakers for overcurrent protection
- Can accommodate VFDs
- Suction guides with strainers
- Suction and discharge butterfly isolation valves
- Starter panels have NEMA 4 rated enclosures
- All vertical (F2) pump models are capable of accommodating the follow Building Automation System control and alarm signals.

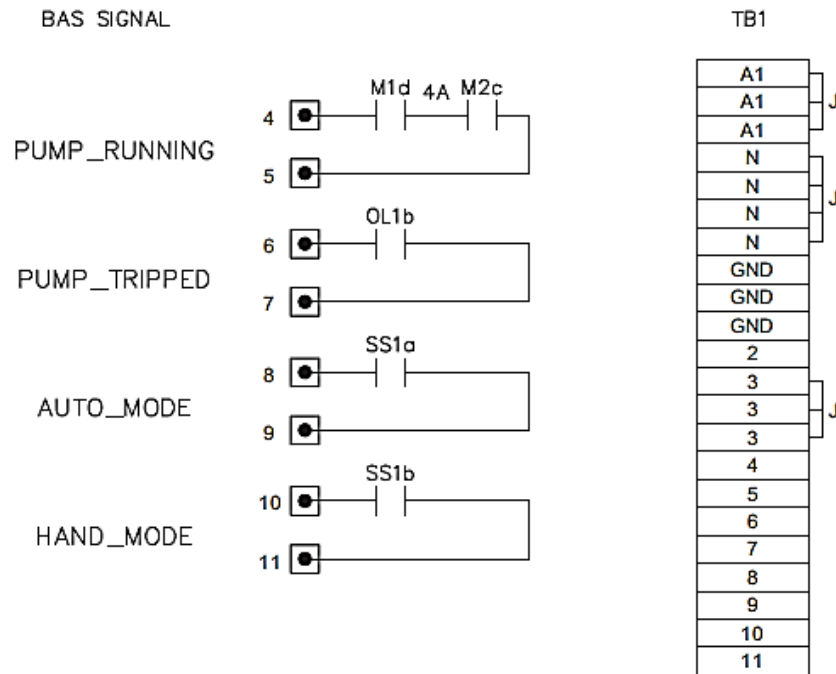
Figure 1. Optional BAS connection points

Parallel and Series Pumps

As an increase to versatility the pumps may be placed in parallel or series. All installations of pumps in parallel or series will be with identical pumps. Placing the pumps in parallel will effectively double the pumping volume while the head remains unchanged. Below is a typical installation diagram.

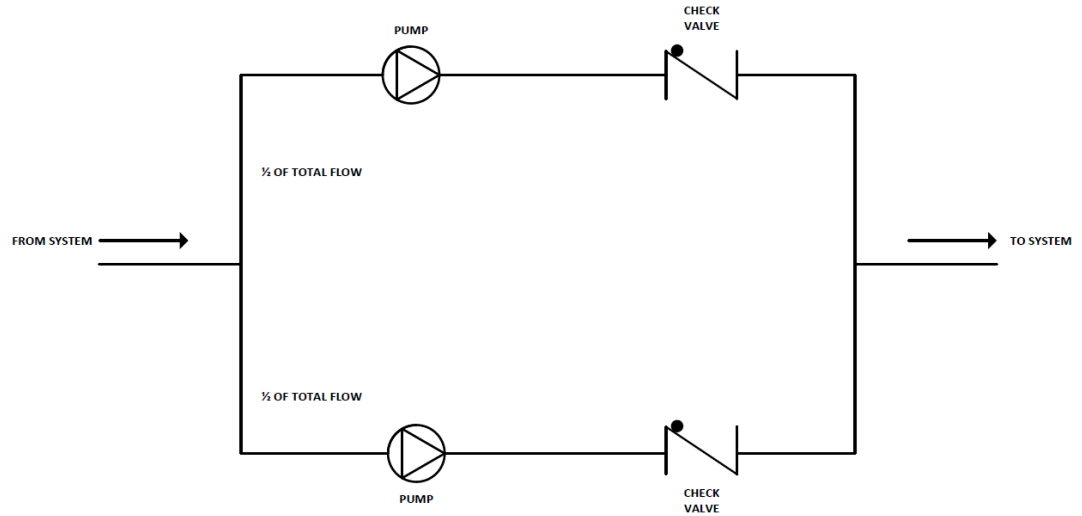

Placing the pumps in series will effectively double the pumping head while the volume remains unchanged. Below is a typical installation diagram.

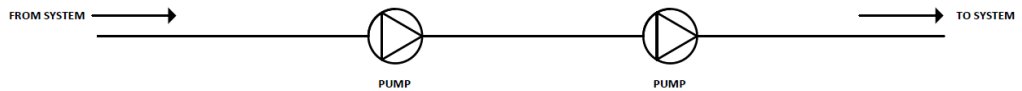



Armstrong

10 Horsepower

CSPC0010F0 (AA through AH)

Table 2. Pump data

Labels	Values
Model Number	4280
Type	Close Coupled
Size	5 x 4 x 10
Impeller Diameter	8.2 inches
Suction Size	4 inch Victaulic
Discharge Size	4 inch. Victaulic

Table 3. Motor data

Labels	Values
Type	TEFC
Horsepower	10
RPM	1800
Voltage	460
FLA	13.6 A

Table 4. Performance data

Labels	Values
Minimum	165 gpm @ 62.7 feet
Maximum	560 gpm @ 52.4 feet

Table 5. Physical dimensions

Labels	Values
Height	4 feet – 4 inches
Width	2 feet – 10 inches
Length	5 feet – 10 inches
Weight	1260 pounds

Notes:

1. Fork pocket dimensions.
2. Actual weight and physical dimensions may vary.

Figure 2. CSPC0010F0 (AA through AH) pump Curve

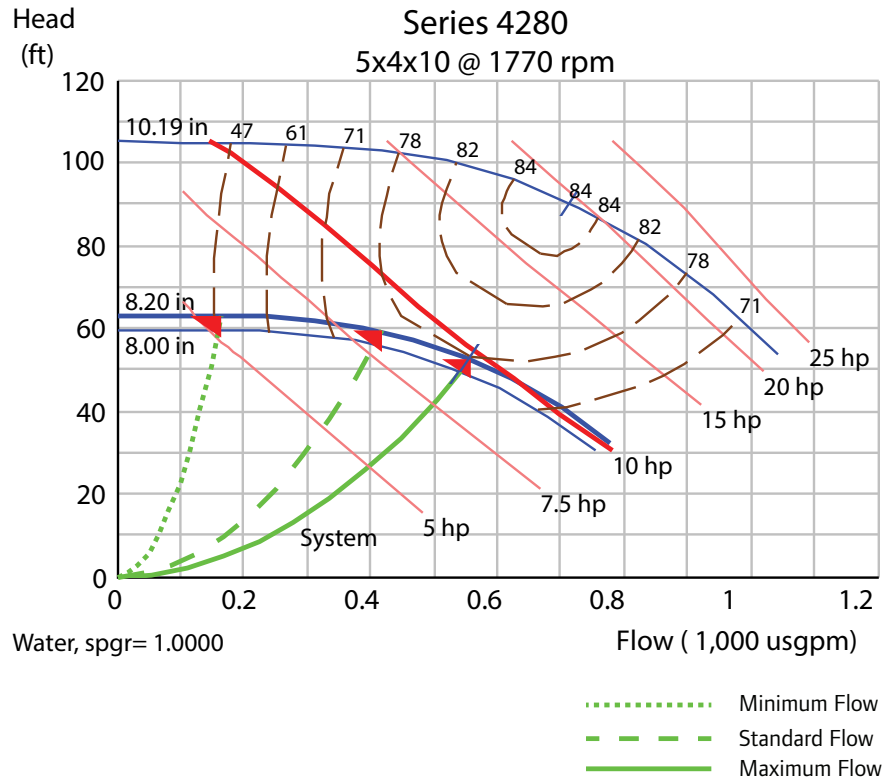

CSPC0010F0 (AL through AO)

Table 6. Pump data

Labels	Values
Model Number	4280
Type	Close Coupled
Size	3 x 1.5 x 6
Impeller Diameter	6.18 inches
Suction Size	4 inch Victaulic
Discharge Size	4 inch Victaulic

Table 7. Motor data

Labels	Values
Type	TEFC
Horsepower	10
RPM	3600
Voltage	460
FLA	12 A

Table 8. Performance data

Labels	Values
Minimum	47 gpm @ 162.5 feet
Maximum	200 gpm @ 136.1 feet

Table 9. Physical dimensions

Labels	Values
Height	4 feet – 6 inches
Width	2 feet – 10 inches
Length	5 feet – 11 inches
Weight	1248 pounds
Fork Pockets	5.5 x 9.5 x 34 inches
Center-to-center Distance	25 inches

Note: Actual weight and physical dimensions may vary.

Figure 3. CSPC0010F0 (AL through AO) pump curve

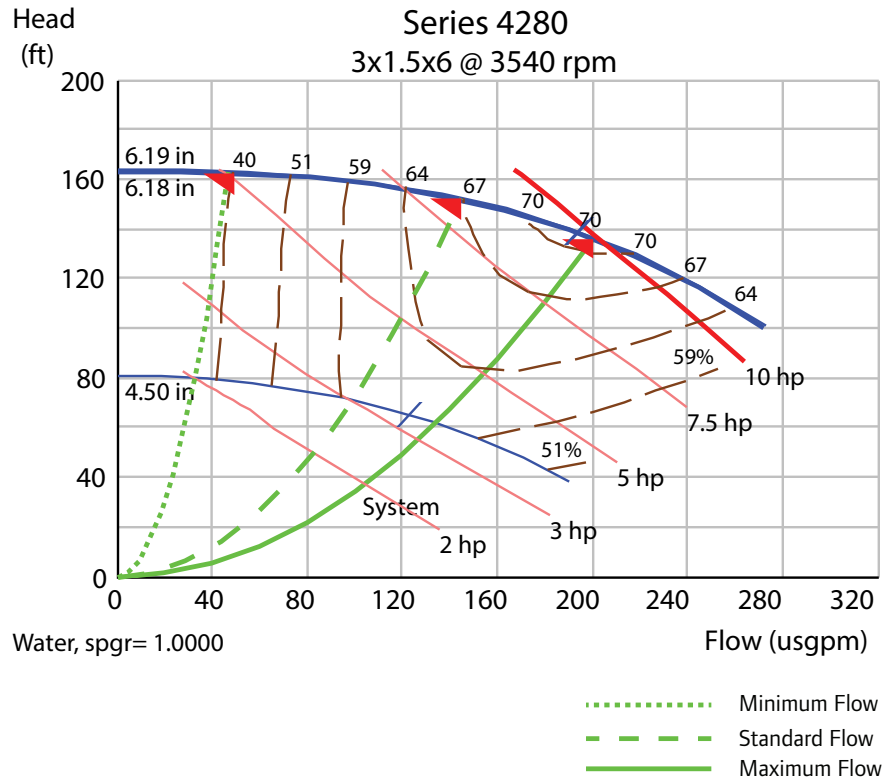

15 Horsepower

CSPC0015F0 (AA through AL)

Table 10. Pump data

Labels	Values
Model Number	4280
Type	Close Coupled
Size	4 x 3 x 11.5
Impeller Diameter	10.9 inches
Suction Size	4 inch Victaulic
Discharge Size	4 inch Victaulic

Table 11. Motor data

Labels	Values
Type	TEFC
Horsepower	15
RPM	1800
Voltage	460
FLA	19.6 A

Table 12. Performance data

Labels	Values
Minimum	119.1 gpm @ 130.3 feet
Maximum	370 gpm @ 118 feet

Table 13. Physical dimensions

Labels	Values
Height	4 feet – 2 inches
Width	2 feet – 10 inches
Length	5 feet – 10 inches
Weight	1500 pounds
Fork Pockets	7 x 2 x 36 inches
Center-to-Center Distance	25 inches

Note: Actual weight and physical dimensions may vary.

Figure 4. CSPC0015F0 (AA through AL) pump curve

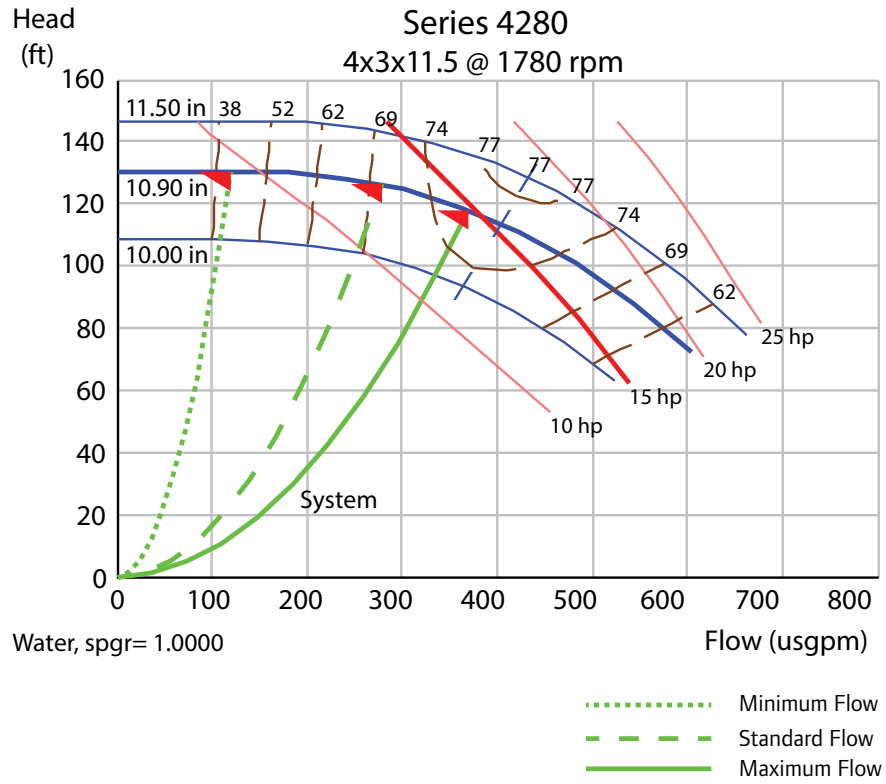

CSPC0015F0 (AM through AR)

Table 14. Pump data

Labels	Values
Model Number	4280
Type	Close Coupled
Size	3 x 2 x 13
Impeller Diameter	11.65 inches
Suction Size	4 inch Victaulic
Discharge Size	4 inch Victaulic

Table 15. Motor data

Labels	Values
Type	TEFC
Horsepower	15
RPM	1800
Voltage	460
FLA	19.6 A

Table 16. Performance data

Labels	Values
Minimum	75 gpm @ 146.5 feet
Maximum	340 gpm @ 111.3 feet

Table 17. Physical dimensions

Labels	Values
Height	4 feet – 6 inches
Width	2 feet – 10 inches
Length	5 feet – 11 inches
Weight	1576 pounds
Fork Pockets	5.5 x 9.5 x 34 inches
Center-to-Center Distance	25 inches

Note: Actual weight and physical dimensions may vary.

Figure 5. CSPC0015F0 (AM through AR) pump curve

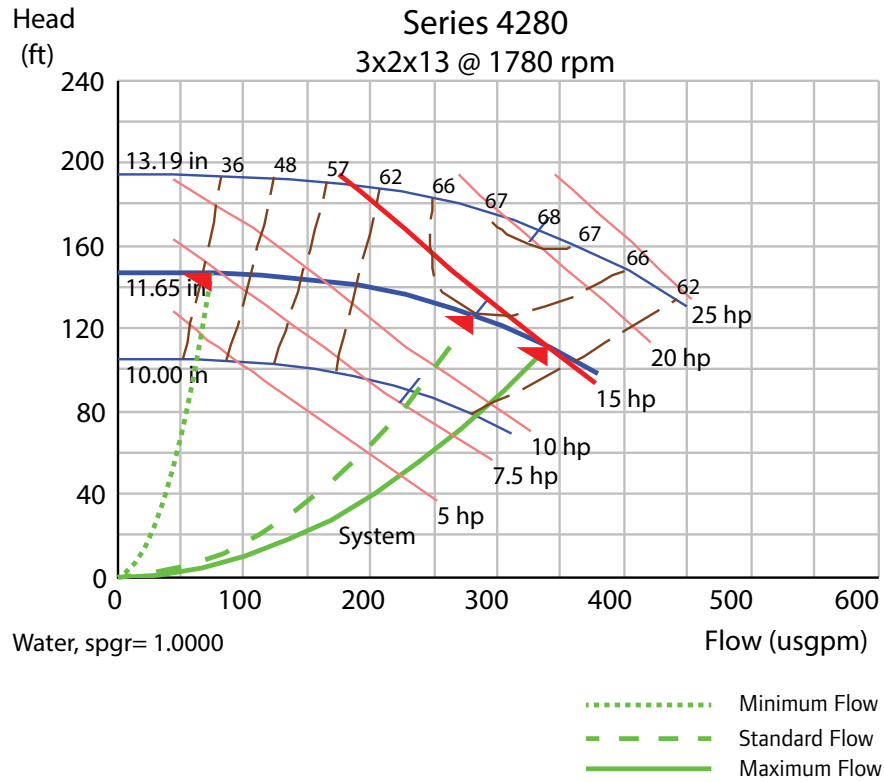

25 Horsepower

CSPC0025F0

Table 18. Pump data

Labels	Values
Model Number	4280
Type	Close Coupled
Size	4 x 4 x 11.5
Impeller Diameter	11.25 inches
Suction Size	6 inch Victaulic
Discharge Size	6 inch Victaulic

Table 19. Motor data

Labels	Values
Type	TEFC
Horsepower	25
RPM	1800
Voltage	460
FLA	34 A

Table 20. Performance data

Labels	Values
Minimum	193.8 gpm @ 128.6 feet
Maximum	808.1 gpm @ 90.5 feet

Table 21. Physical dimensions

Labels	Values
Height	5 feet – 0 inches
Width	3 feet – 8 inches
Length	7 feet – 2 inches
Weight	2030 pounds
Fork Pockets	5.5 x 9.5 x 44 inches
Center-to-Center Distance	25 inches

Note: Actual weight and physical dimensions may vary.

Figure 6. CSPC0025F0 pump curve

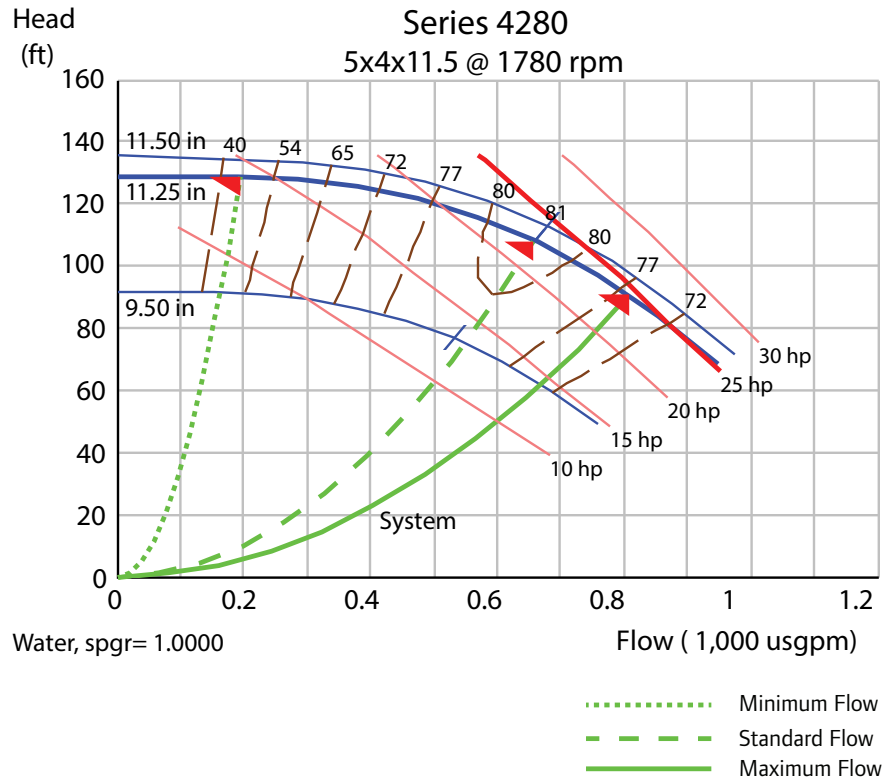

30 Horsepower

CSPC0030F0

Table 22. Pump data

Labels	Values
Model Number	4280
Type	Close Coupled
Size	4 x 3 x 13
Impeller Diameter	12.2 inches
Suction Size	6 inch Victaulic
Discharge Size	6 inch Victaulic

Table 23. Motor data

Labels	Values
Type	TEFC
Horsepower	30
RPM	1800
Voltage	460
FLA	38 A

Table 24. Performance data

Labels	Values
Minimum	140 gpm @ 170.2 feet
Maximum	647 gpm @ 131.4 feet

Table 25. Physical dimensions

Labels	Values
Height	5 feet– 0 inches
Width	3 feet – 8 inches
Length	7 feet – 2 inches
Weight	2220 pounds
Fork Pockets	5.5 x 9.5 x 44 inches
Center-to-Center Distance	25 inches

Note: Actual weight and physical dimensions may vary.

Figure 7. CSPC0030F0 pump curve

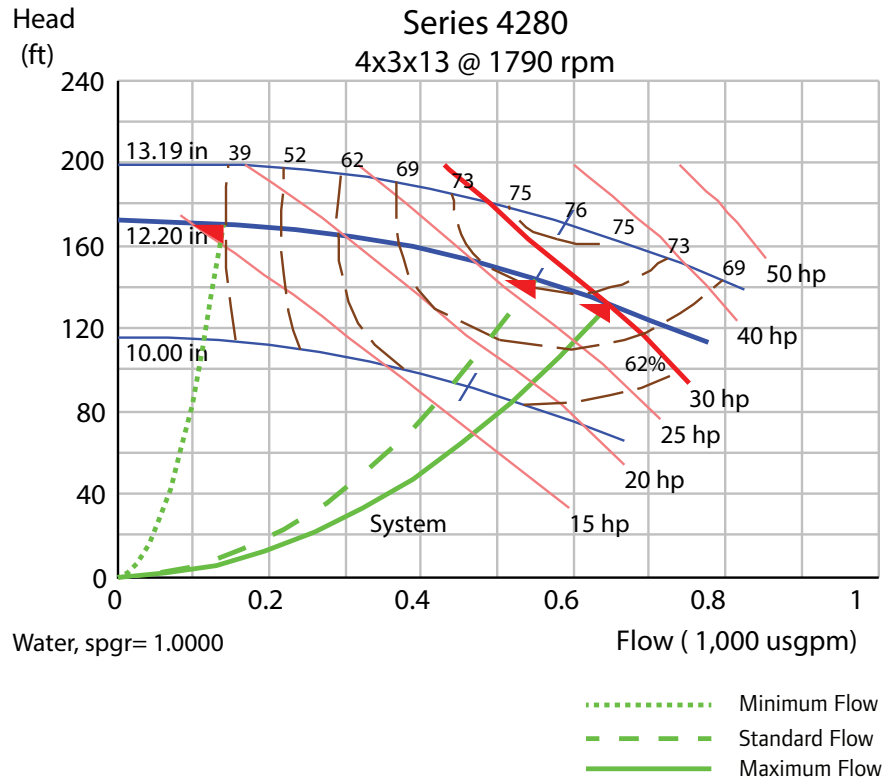

RSPC0030F2AB and RSPC0030F2AC

Table 26. Pump data

Labels	Values
Model Number	4300
Type	Split Coupled Vertical Line
Size	5 x 5 x 11.5
Impeller Diameter	11.26 inches
Suction Size	6 inch Victaulic
Discharge Size	6 inch Victaulic

Table 27. Motor data

Labels	Values
Type	TEFC
Horsepower	30
RPM	1800
Voltage	460
FLA	35.1 A

Table 28. Performance data

Labels	Values
Minimum	190 gpm @ 130.5 feet
Maximum	793 gpm @ 87.9 feet

Table 29. Physical dimensions

Labels	Values
Height	5 feet – 3 inches
Width	3 feet. – 5 inches
Length	5 feet – 5 inches
Weight	4000 pounds
Fork Pockets	7.5 x 5.5 x 39 inches
Center-to-Center Distance	25 inches

Note: Actual weight and physical dimensions may vary.

Figure 8. 30 HP pump curve – 1800 rpm

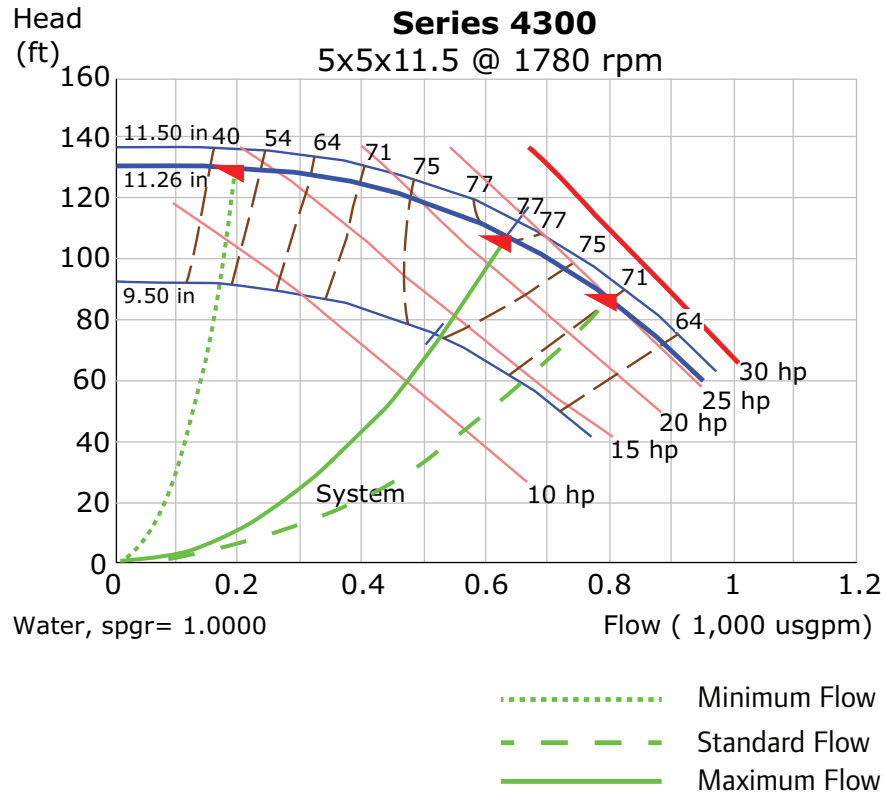
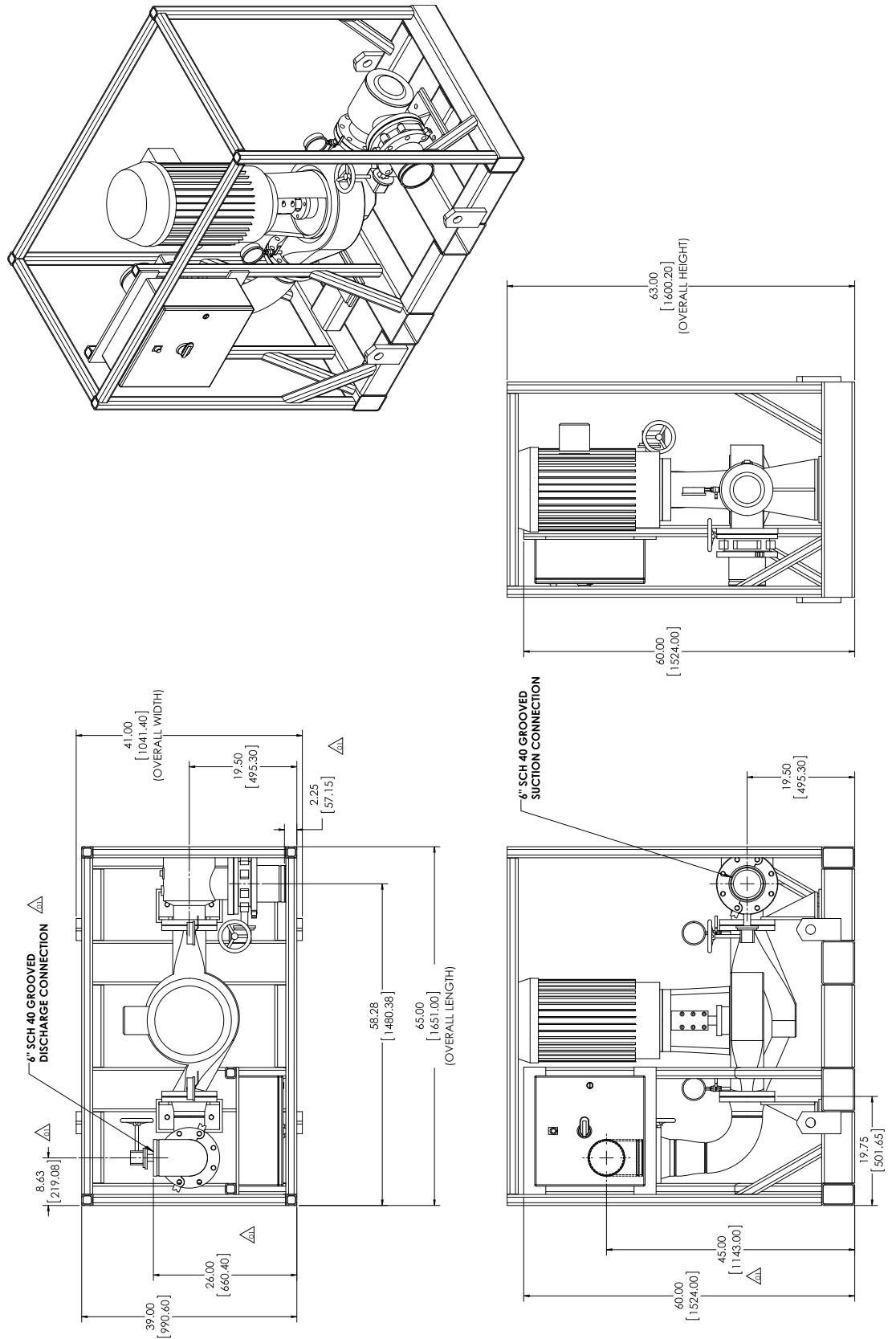

Figure 9. RSPC0030F2 unit dimensions





Armstrong

RSPC0030F2

Table 30. Pump data

Labels	Values
Model Number	4300
Type	Split Coupled Vertical Line
Size	5 x 5 x 11.5
Impeller Diameter	11.26 inches
Suction Size	6 inch Victaulic
Discharge Size	6 inch Victaulic

Table 31. Motor data

Labels	Values
Type	TEFC
Horsepower	30
RPM	1800
Voltage	460
FLA	35.1 A

Table 32. Performance data

Labels	Values
Minimum	190 gpm @ 130.5 feet
Maximum	793 gpm @ 87.9 feet

Table 33. Physical dimensions

Labels	Values
Height	5 feet – 3 inches
Width	3 feet – 5 inches
Length	5 feet – 5 inches
Weight	4000 pounds
Fork Pockets	7.5 x 5.5 x 39 inches
Center-to-Center Distance	25 inches

Note: Actual weight and physical dimensions may vary.

Figure 10. 30 HP pump curve – 1800 rpm

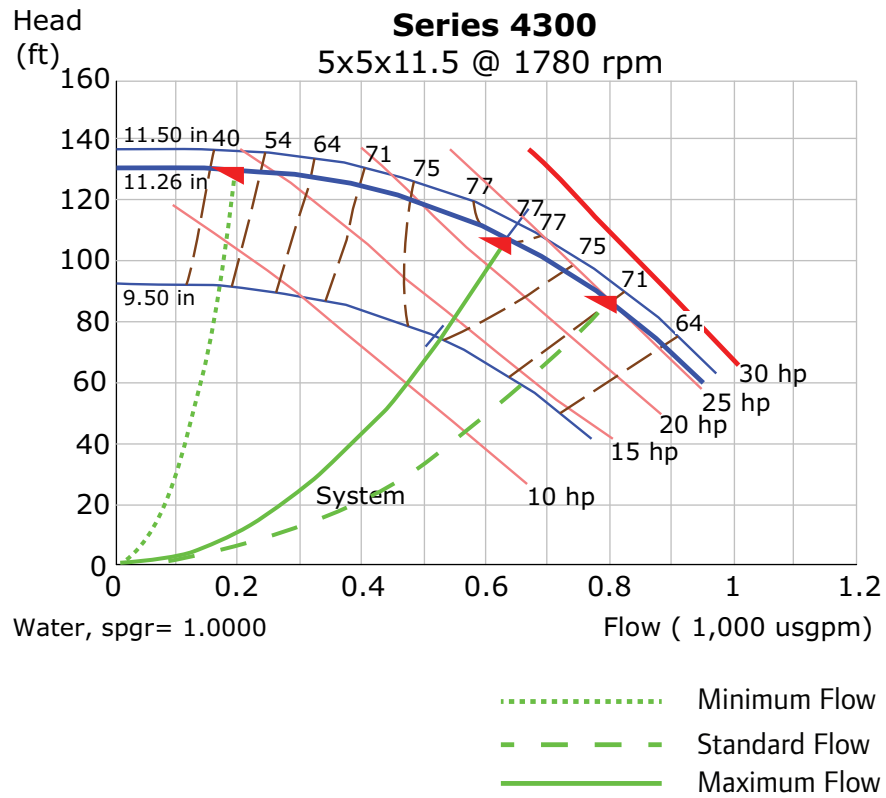
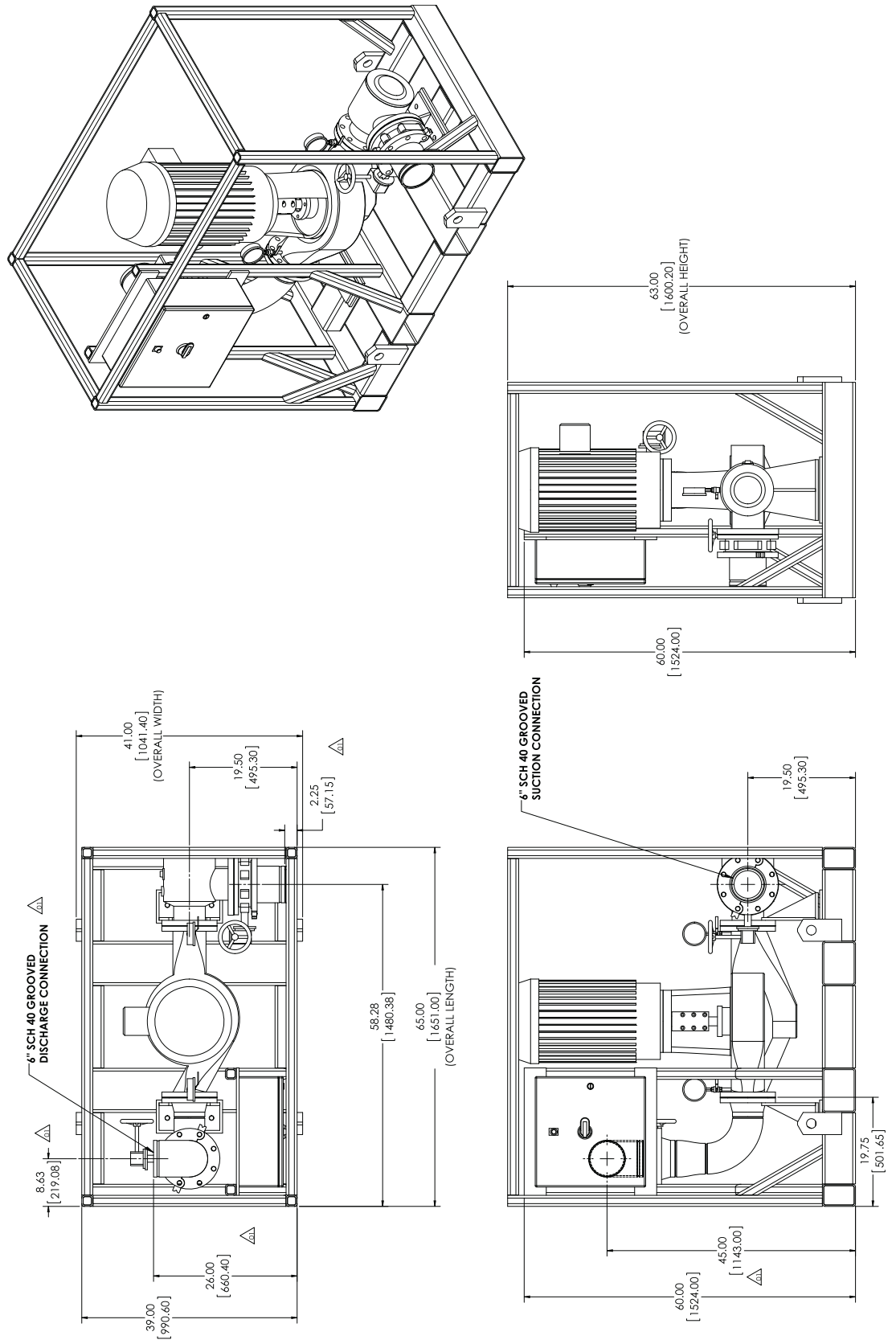

Figure 11. RSPC0030F2 unit dimensions



40 Horsepower

CSPC0040F0

Table 34. Pump data

Labels	Values
Model Number	4280
Type	Close coupled
Size	6 x 5 x 11.5
Impeller Diameter	11.47 inches
Suction Size	6 inch Victaulic
Discharge Size	6 inch Victaulic

Table 35. Motor data

Labels	Values
Type	TEFC
Horsepower	40
RPM	1800
Voltage	460
FLA	50 A

Table 36. Performance data

Labels	Values
Minimum	300.9 gpm @ 127.1 feet
Maximum	1253.6 gpm @ 92.1 feet

Table 37. Physical dimensions

Labels	Values
Height	3 feet – 10 inches
Width	3 feet – 11 inches
Length	5 feet – 2 inches
Weight	1610 pounds

Notes:

1. Fork pocket dimensions.
2. Actual weight and physical dimensions may vary.

Figure 12. CSPC0040F0 pump curve

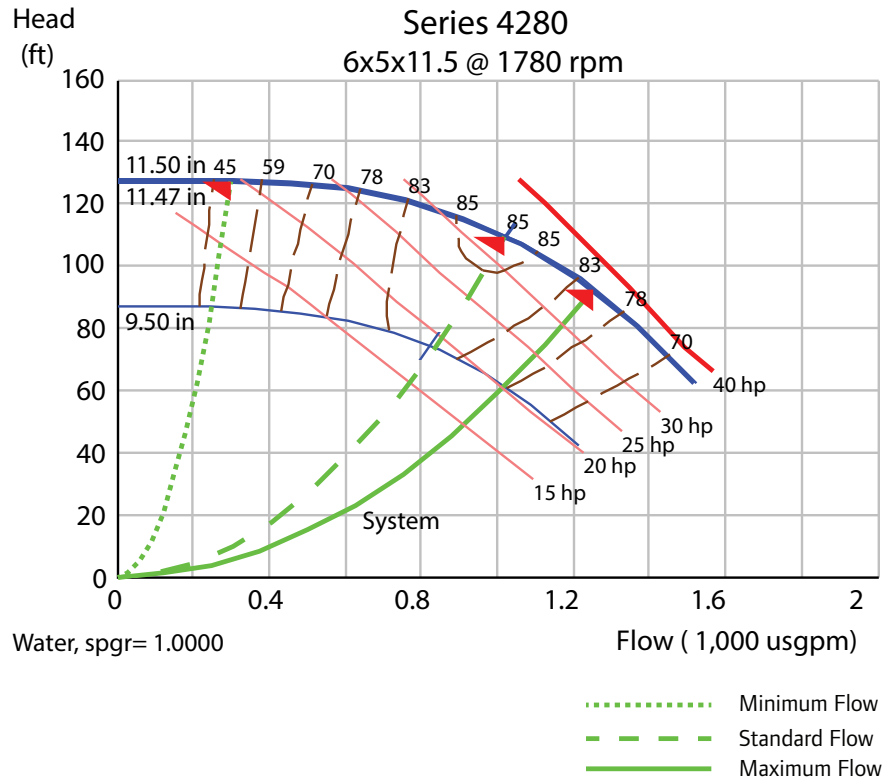

RSPC0040F2

Table 38. Pump data

Labels	Values
Model number	4300
Type	Split Coupled Vertical Line
Size	6 x 6 x 13
Impeller diameter	11.76 inches
Suction size	6 inch Victaulic
Discharge size	6 inch Victaulic

Table 39. Motor data

Labels	Values
Type	TEFC
Horsepower	40
RPM	1800
Voltage	460
FLA	52 A

Table 40. Performance data

Labels	Values
Minimum	300 gpm @ 138.9 feet
Maximum	1249 gpm @ 89.4 feet

Table 41. Physical dimensions

Labels	Values
Height	5 feet – 9 inches
Width	3 feet – 9 inches
Length	6 feet – 11 inches
Weight	3355 pounds
Fork Pockets	7.5 x 5.5 x 43 inches
Center-to-center Distance	28 inches

Note: Actual weight and physical dimensions may vary.

Figure 13. RSPC0040F2 pump curve

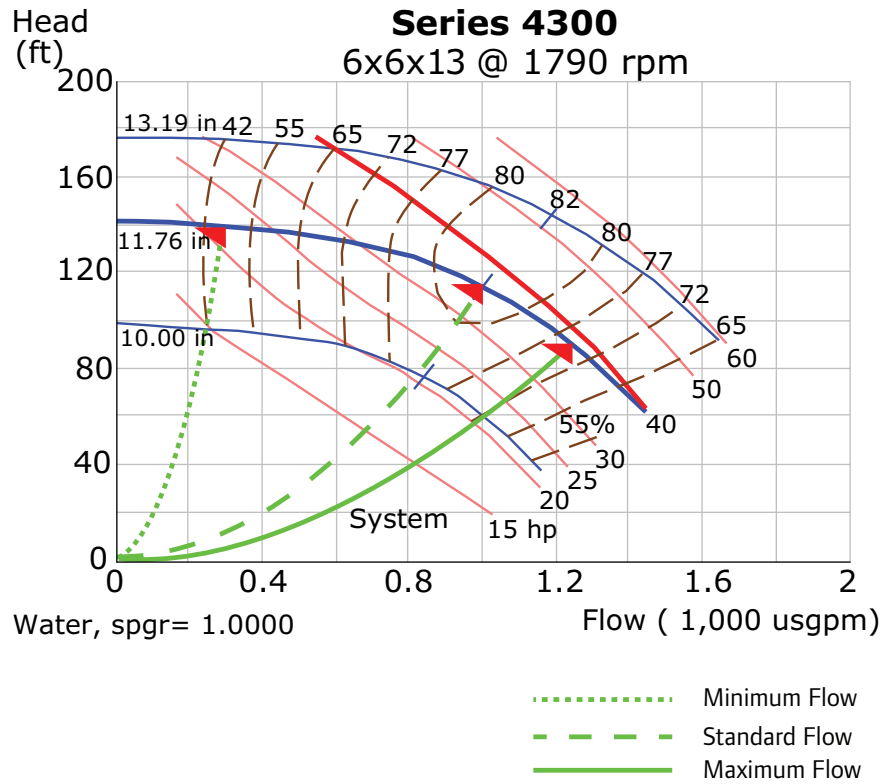
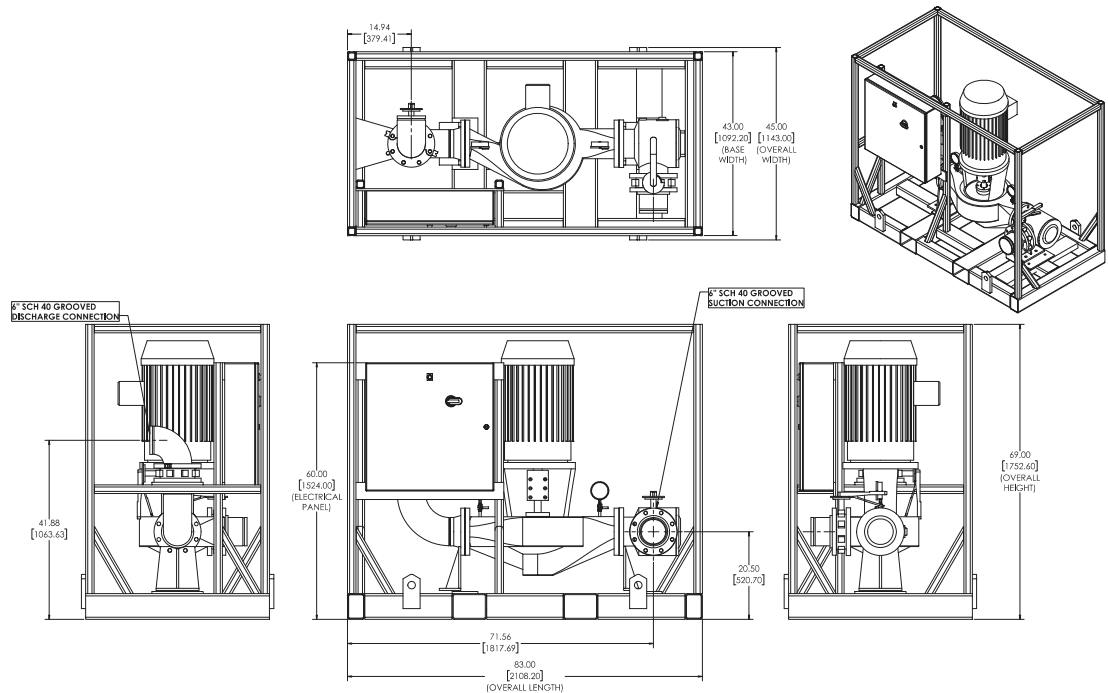

Figure 14. RSPC0040F2 unit dimensions



50 Horsepower

CSPC0050F0

Table 42. Pump data

Labels	Values
Model Number	4280
Type	Close Coupled
Size	6 x 4 x 13
Impeller Diameter	13.17 inches
Suction Size	6 inch Victaulic
Discharge Size	6 inch Victaulic

Table 43. Motor data

Labels	Values
Type	TEFC
Horsepower	50
RPM	1800
Voltage	460
FLA	60 A

Table 44. Performance data

Labels	Values
Minimum	200 gpm @ 178.1 feet
Maximum	1159 gpm @ 122.9 feet

Table 45. Physical dimensions

Labels	Values
Height	5 feet – 0 inches
Width	3 feet – 8 inches
Length	7 feet – 2 inches
Weight	2493 pounds
Fork Pockets	5.5 x 9.5 44 inches
Center-to-Center Distance	25 inches

Note: Actual weight and physical dimensions may vary.

Figure 15. CSPC0050F0 pump curve

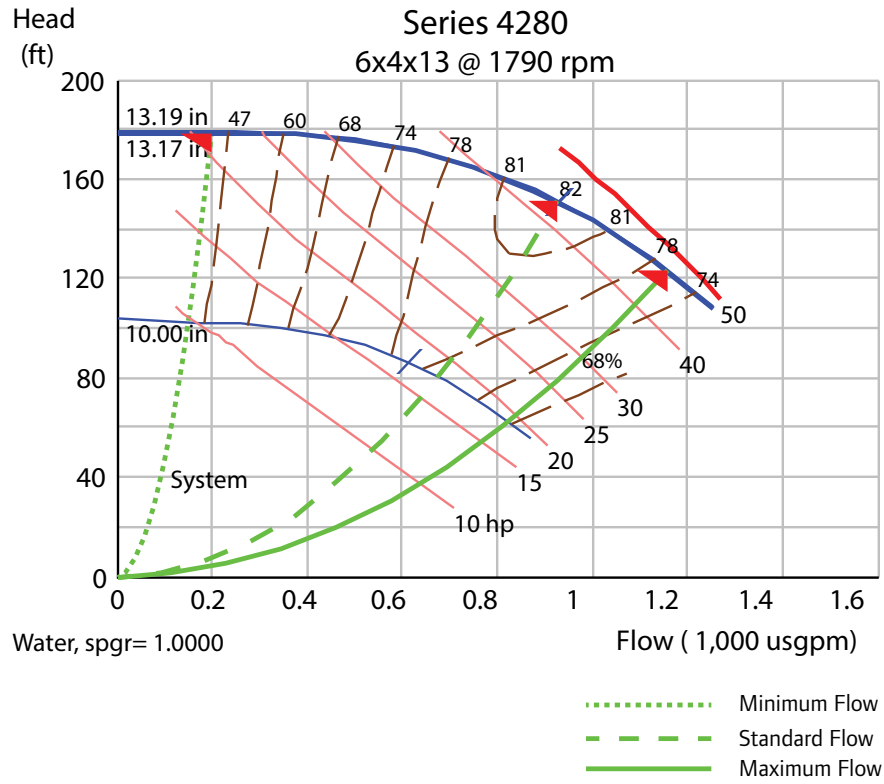

RSPC0050F2

Table 46. Pump data

Labels	Values
Model Number	4300
Type	Split Coupled Vertical Line
Size	8 x 8 x 10
Impeller Diameter	10.09 inches
Suction Size	6 inch Victaulic
Discharge Size	6 inch. Victaulic

Table 47. Motor data

Labels	Values
Type	TEFC
Horsepower	50
RPM	1800
Voltage	460
FLA	65 A

Table 48. Performance data

Labels	Values
Minimum	504 gpm @ 103.6 feet
Maximum	2101 gpm @ 63.7 feet

Table 49. Physical dimensions

Labels	Values
Height	5 feet– 6 inches
Width	3 feet – 8 inches
Length	8 feet – 1 inch
Weight	4000 pounds
Fork Pockets	7.5 x 5.5 x 42 inches
Center-to-Center Distance	28 inches

Note: Actual weight and physical dimensions may vary.

Figure 16. RSPC0050F2 pump curve

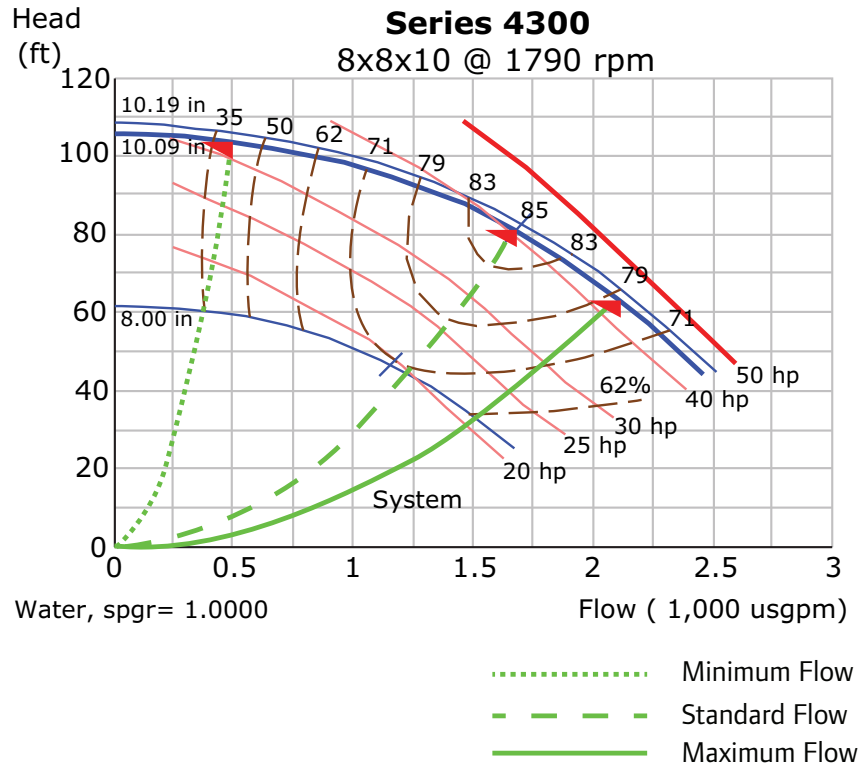
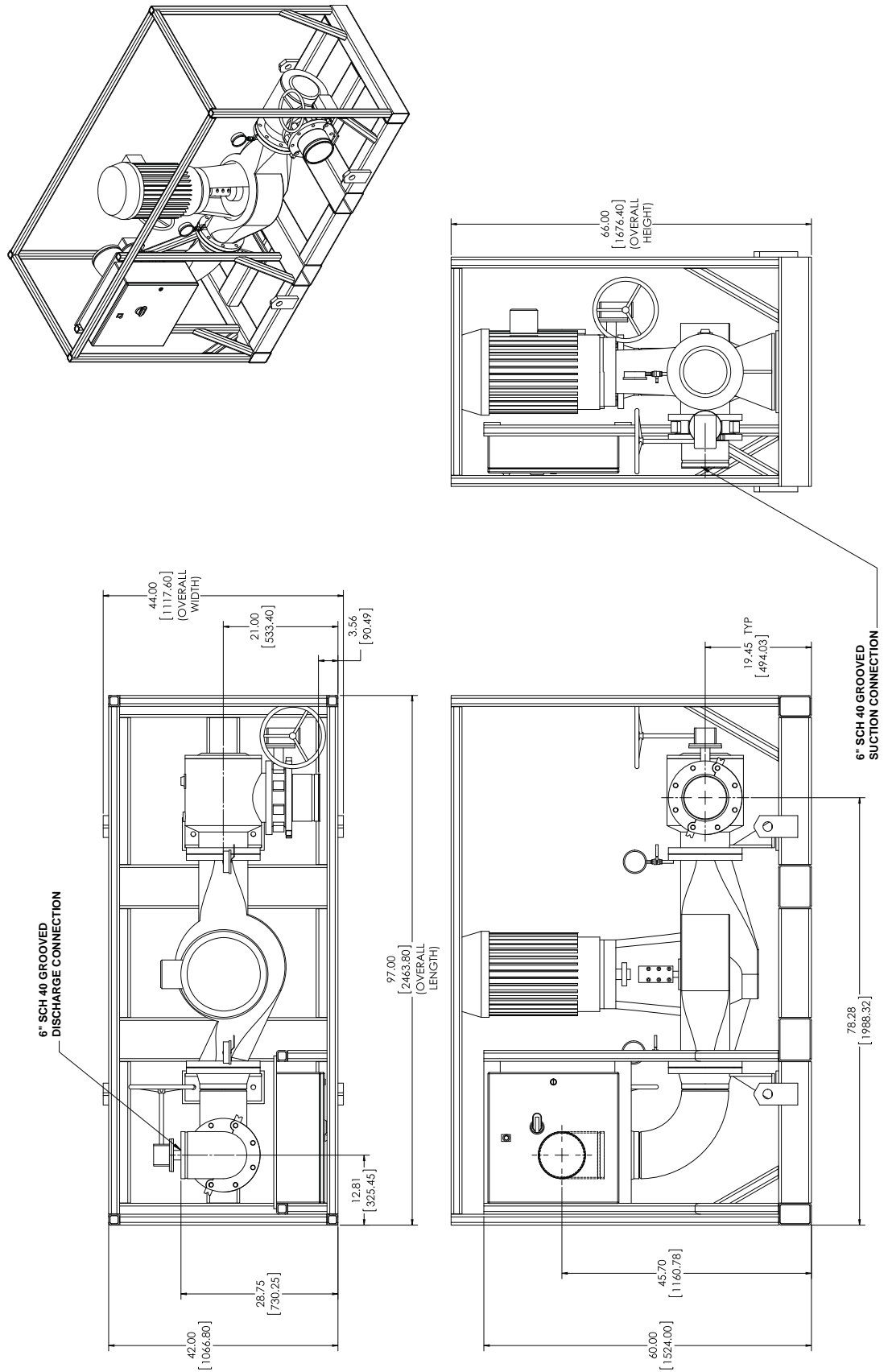

Figure 17. RSPC0050F2 unit dimensions





Armstrong

60 Horsepower

CSPC0060F0 (AA through AL)

Table 50. Pump data

Labels	Values
Model Number	4030
Type	Close coupled
Size	8 x 6 x 13
Impeller Diameter	11.00 inches
Suction Size	10 inch Victaulic
Discharge Size	10 inch Victaulic

Table 51. Motor data

Labels	Values
Type	TEFC
Horsepower	60
RPM	1800
Voltage	460
FLA	72 A

Table 52. Performance data

Labels	Values
Minimum	484.1 gpm @ 123.8 feet
Maximum	1800 gpm @ 104.8 feet

Table 53. Physical dimensions

Labels	Values
Height	4 feet – 4 inches
Width	5 feet – 6 inches
Length	6 feet – 0 inches
Weight	2375 pounds

Notes:

1. Fork pocket dimensions.
2. Actual weight and physical dimensions may vary.

Figure 18. CSPC0060F0 (AA through AL) pump curve

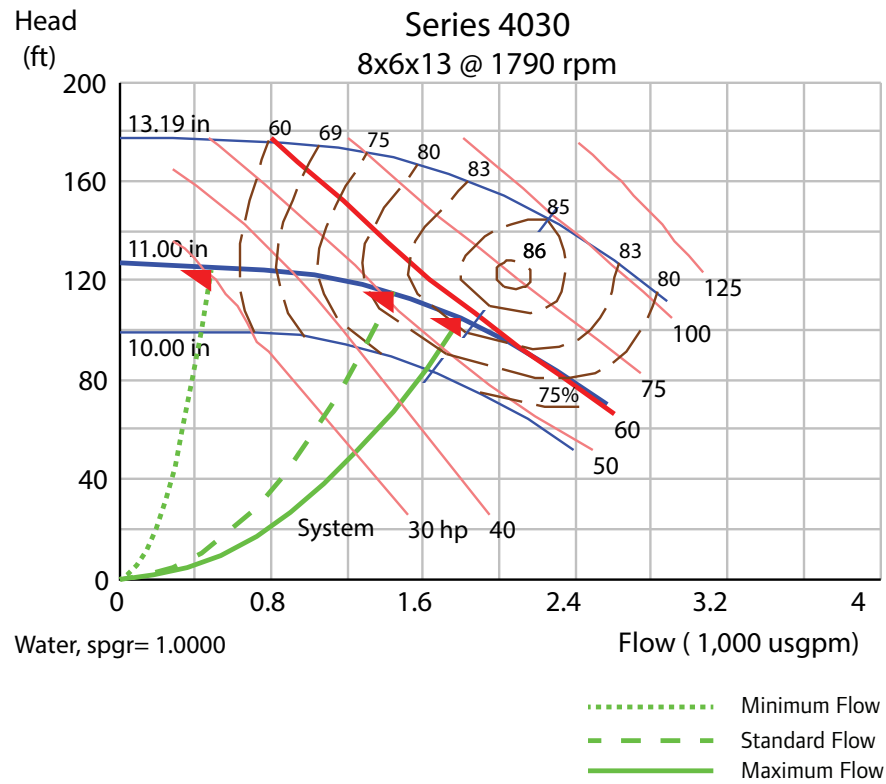



Armstrong

CSPC0060F0 (AM through AU)

Table 54. Pump data

Labels	Values
Model Number	4030
Type	Close Coupled
Size	8 x 6 x 13
Impeller Diameter	11.47 inches
Suction Size	10 inch Victaulic
Discharge Size	10 inch Victaulic

Table 55. Motor data

Labels	Values
Type	TEFC
Horsepower	60
RPM	1800
Voltage	460
FLA	72 A

Table 56. Performance data

Labels	Values
Minimum	425 gpm @ 135.2 feet
Maximum	1550 gpm @ 124.9 feet

Table 57. Physical dimensions

Labels	Values
Height	6 feet– 10 inches
Width	5 feet – 7 inches
Length	7 feet – 8 inches
Weight	4300 pounds
Fork Pockets	5.5 x 9.5 x 67 inches
Center-to-Center Distance	53.5 inches

Note: Actual weight and physical dimensions may vary.

Figure 19. CSPC0060F0 (AM through AU) pump curve

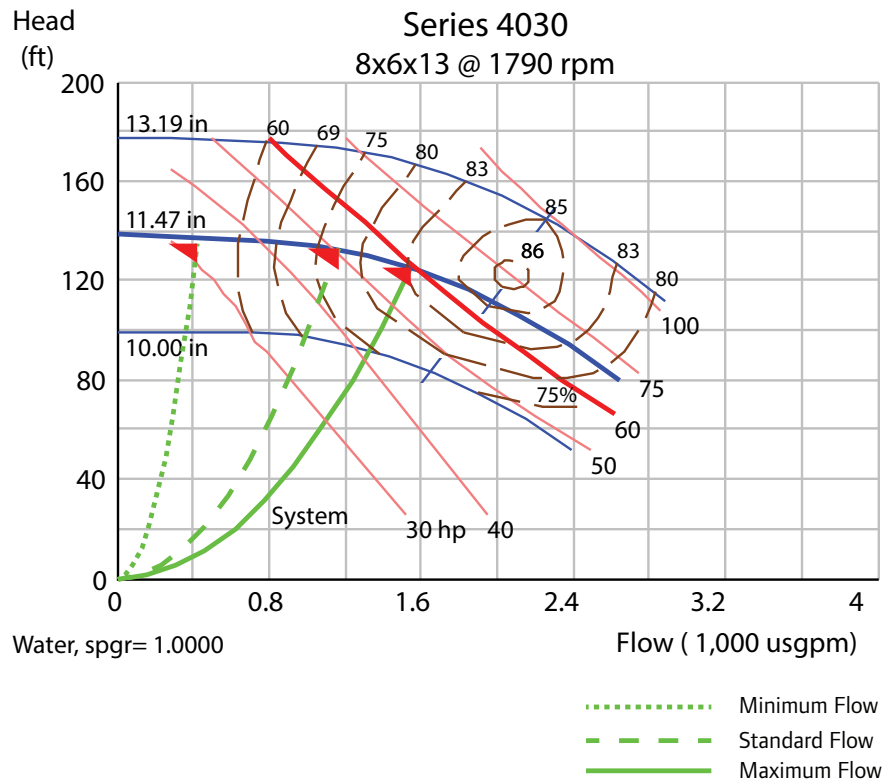



Armstrong

CSPC0060F1

Table 58. Pump data

Labels	Values
Model Number	4600
Type	Horizontal Split Case
Size	6 x 5 x 15
Impeller Diameter	13.02 inches
Suction Size	6 inch Victaulic
Discharge Size	6 inch Victaulic

Table 59. Motor data

Labels	Values
Type	TEFC
Horsepower	60
RPM	1800
Voltage	460
FLA	72 A

Table 60. Performance data

Labels	Values
Minimum	370.8 gpm @ 180.3 feet
Maximum	1544.9 gpm @ 118.6 feet

Table 61. Physical dimensions

Labels	Values
Height	5 feet – 4 inches
Width	5 feet – 7 inches
Length	5 feet – 3 inches
Weight	34005 pounds

Notes:

1. Fork pocket dimensions.
2. Actual weight and physical dimensions may vary.

Figure 20. CSPC0060F1 pump curve

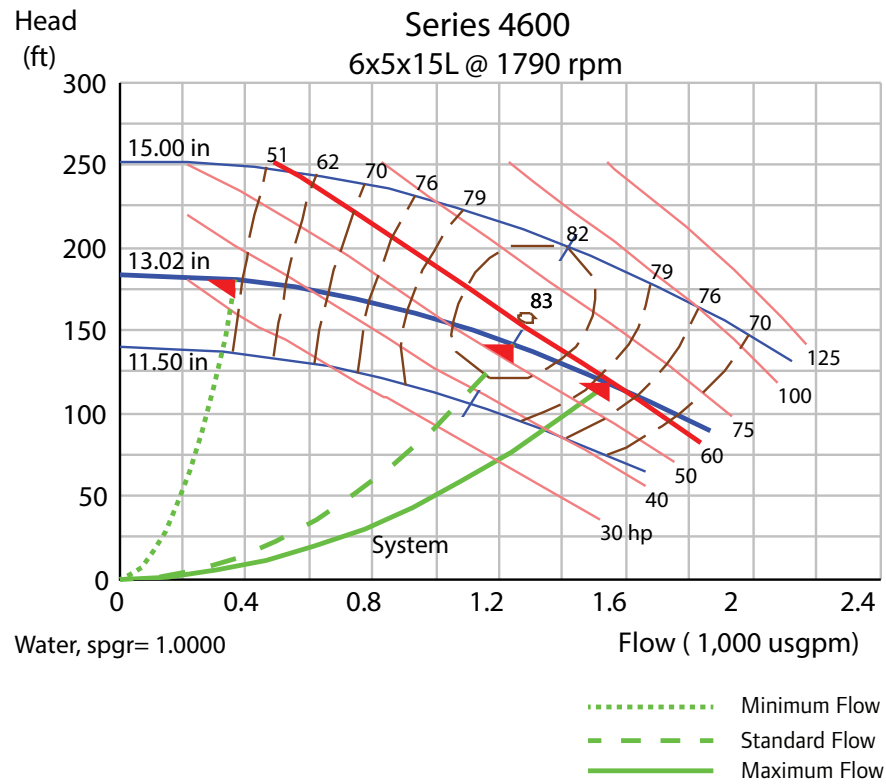



Armstrong

100 Horsepower

CSPC0100F0

Table 62. Pump data

Labels	Values
Model Number	4030
Type	Close Coupled
Size	10 x 8 x 13
Impeller Diameter	11.59 inches
Suction Size	10 inch Victaulic
Discharge Size	10 inch Victaulic

Note: Triple duty valve mounted on discharge side.

Table 63. Motor data

Labels	Values
Type	TEFC
Horsepower	100
RPM	1800
Voltage	460
FLA	115 A

Table 64. Performance data

Labels	Values
Minimum	772.1 gpm @ 121.7 feet
Maximum	3217.1 gpm @ 83.4 feet

Table 65. Physical dimensions

Labels	Values
Height	6 feet – 7 inches
Width	5 feet – 4 inches
Length	8 feet – 7 inches
Weight	4993 pounds

Notes:

1. Fork pocket dimensions.
2. Actual weight and physical dimensions may vary.

Figure 21. CSPC0100F0 pump curve

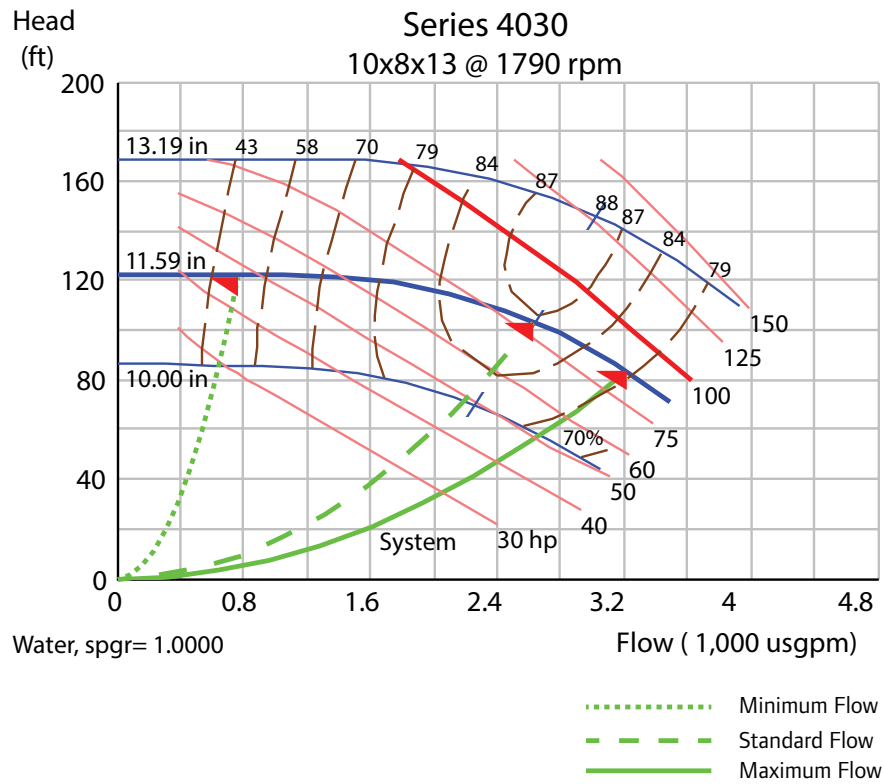



Armstrong

125 Horsepower

CSPC0125F1 (AA through AF)

Table 66. Pump data

Labels	Values
Model Number	4600
Type	Horizontal Split Case
Size	12 x 10 x 12.5
Impeller Diameter	11.2 inches
Suction Size	10 inch Victaulic
Discharge Size	10 inch Victaulic

Notes:

1. These pump models do not come with inlet suction guides and strainers.
2. Triple duty valve mounted on discharge side.

Table 67. Motor data

Labels	Values
Type	TEFC
Horsepower	125
RPM	1800
Voltage	460
FLA	147 A

Table 68. Performance data

Labels	Values
Minimum	1172.3 gpm @ 130.1 feet
Maximum	4884.4 gpm @ 60 feet

Table 69. Physical dimensions

Labels	Values
Height	5 feet – 4 inches
Width	7 feet – 4 inches
Length	6 feet – 7 inches
Weight	4300 pounds

Notes:

1. Fork pocket dimensions.
2. Actual weight and physical dimensions may vary.

Figure 22. CSPC0125F1 (AA through AF) pump curve

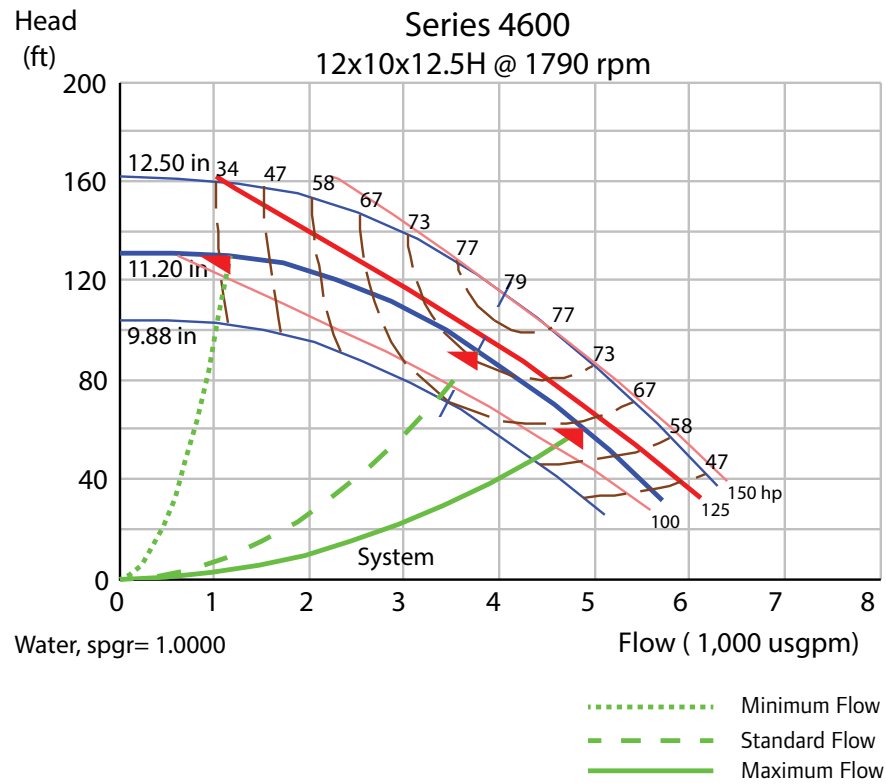



Armstrong

CSPC0125F1 (AG through AQ)

Table 70. Pump data

Labels	Values
Model Number	4600
Type	Horizontal Split Case
Size	12 x 10 x 15 H
Impeller Diameter	11.2 inches
Suction Size	10 inch Victaulic
Discharge Size	10 inch Victaulic

Note: Triple duty valve mounted on discharge side.

Table 71. Motor data

Labels	Values
Type	TEFC
Horsepower	125
RPM	1800
Voltage	460
FLA	147 A

Note: Triple duty valve mounted on discharge side.

Table 72. Performance data

Labels	Values
Minimum	1172.3 gpm @ 134.9 feet
Maximum	3100 gpm ^(a) @ 105 feet

^(a) Extended operation at this gpm may affect life of motor

Table 73. Physical Dimensions

Labels	Values
Height	5 feet – 4 inches
Width	7 feet – 4 inches
Length	6 feet – 7 inches
Weight	4300 pounds

Notes:

1. Fork pocket dimensions.
2. Actual weight and physical dimensions may vary.

Figure 23. CSPC0125F1 (AG through AQ) pump curve

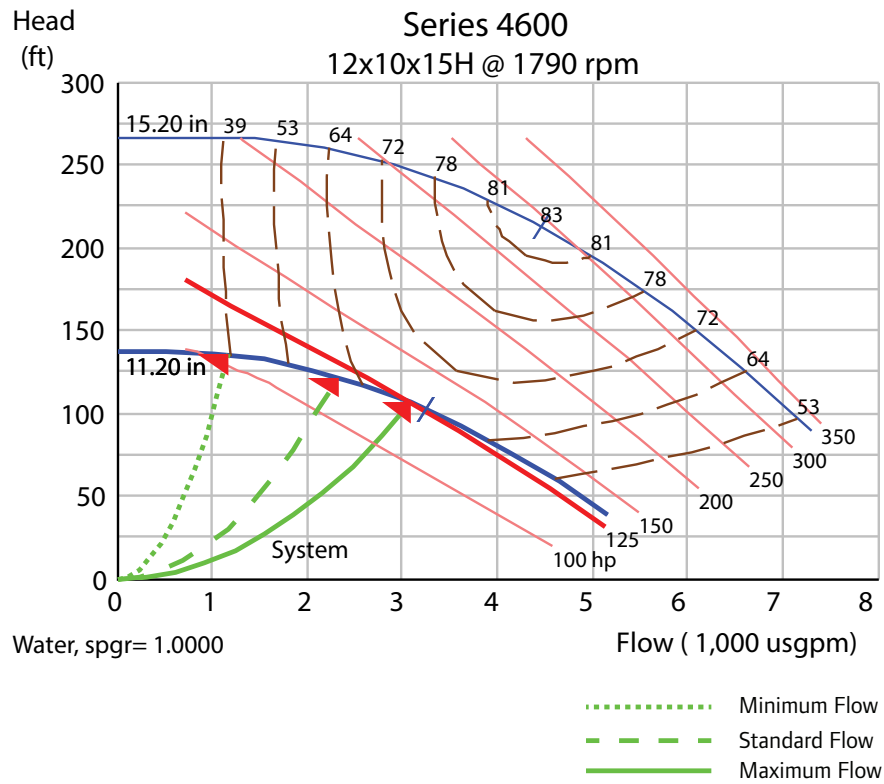



Armstrong

RSPC0125F2

Table 74. Pump data

Labels	Values
Model Number	4300
Type	Split Coupled Vertical Inline
Size	12 x 12 x 13
Impeller Diameter	11.08 inches
Suction Size	10 inch Victaulic
Discharge Size	10 inch Victaulic

Note: Triple duty valve mounted on discharge side.

Table 75. Motor data

Labels	Values
Type	TEFC
Horsepower	125
RPM	1800
Voltage	460
FLA	156 A

Table 76. Performance data

Labels	Values
Minimum	1150 gpm @ 121.2 feet
Maximum	4790 gpm @ 71.2 feet

Table 77. Physical dimensions

Labels	Values
Height	7 feet – 8 inches
Width	5 feet – 7 inches
Length	6 feet – 7 inches
Weight	9760 pounds
Fork Pockets	7.5 x 5.5 x 65 inches
Center-to-Center Distance	28 inches

Note: Actual weight and physical dimensions may vary.

Figure 24. RSPC0125F2 pump curve

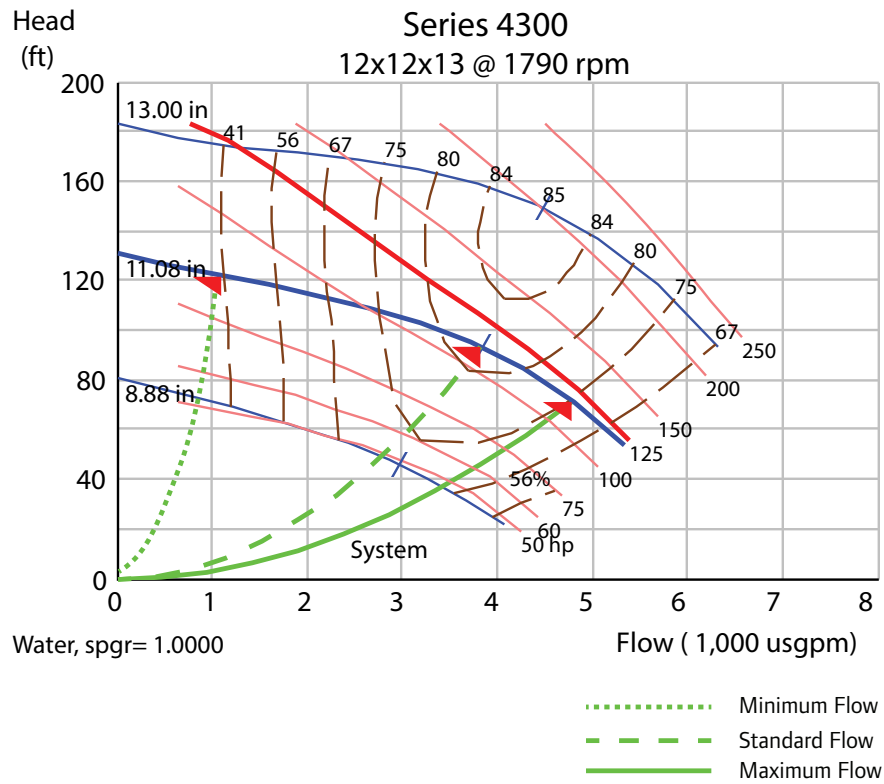
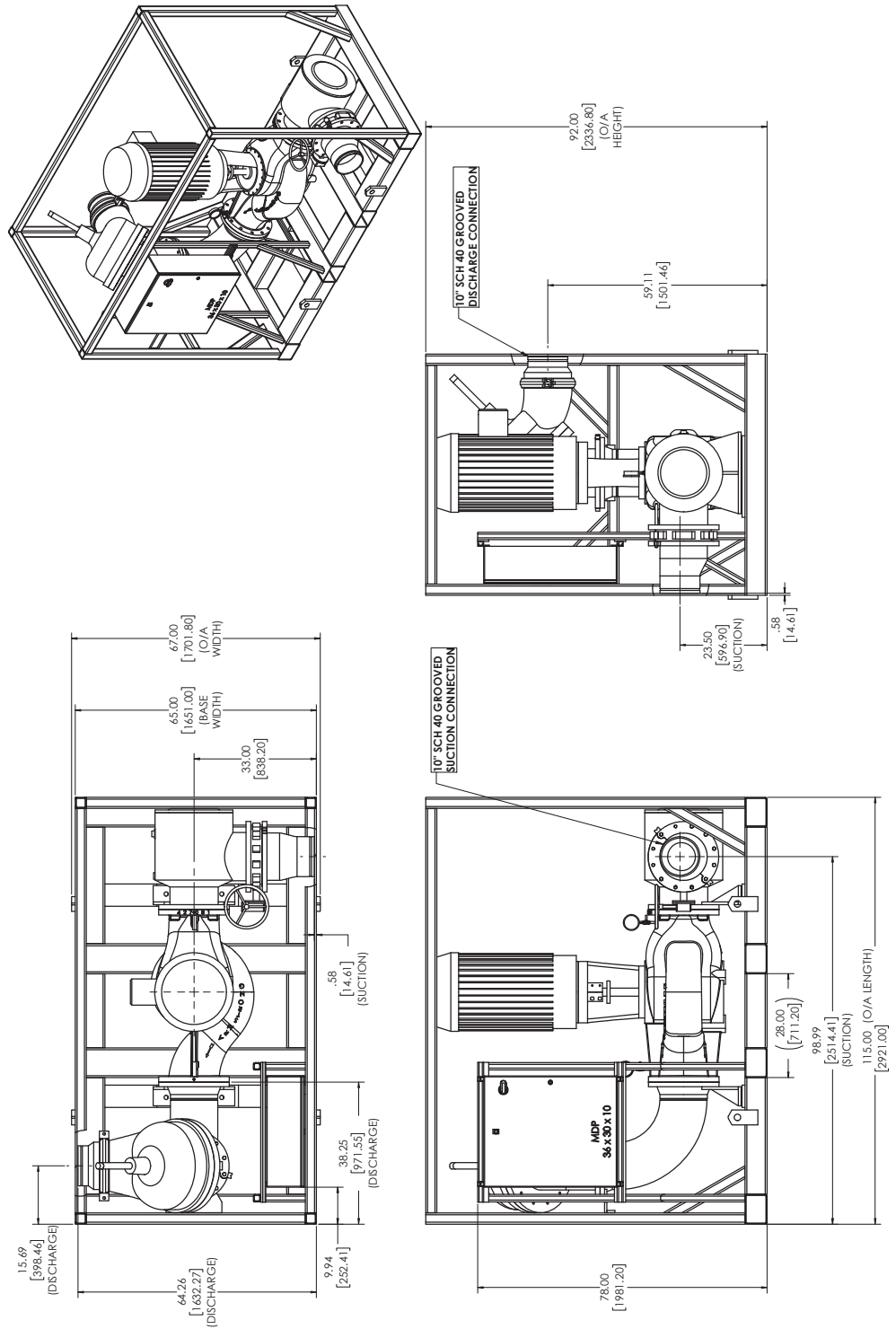

Figure 25. RSPC0125F2 unit dimensions





Integral Pumps

25 Ton CGAM

Table 78. Pump data

Labels	Values
Model Number	4270
Type	Close Coupled
Size	2 x 1.5 x 5.5 ^(a)
Impeller diameter	8.2 inches

^(a) Chiller inlet/outlet connections = 2.5 inch Victaulic

Table 79. Motor data

Labels	Values
Type	TEFC
Horsepower	5
RPM	3600
Voltage	460
FLA	6.2 A

Table 80. Performance data

Labels	Values
Minimum	25 gpm @ 122.2 feet
Nominal Flow	84.5 gpm @ 107.9 feet
Maximum	104 gpm @ 89.3 feet

Figure 26. 25 ton CGAM pump curve

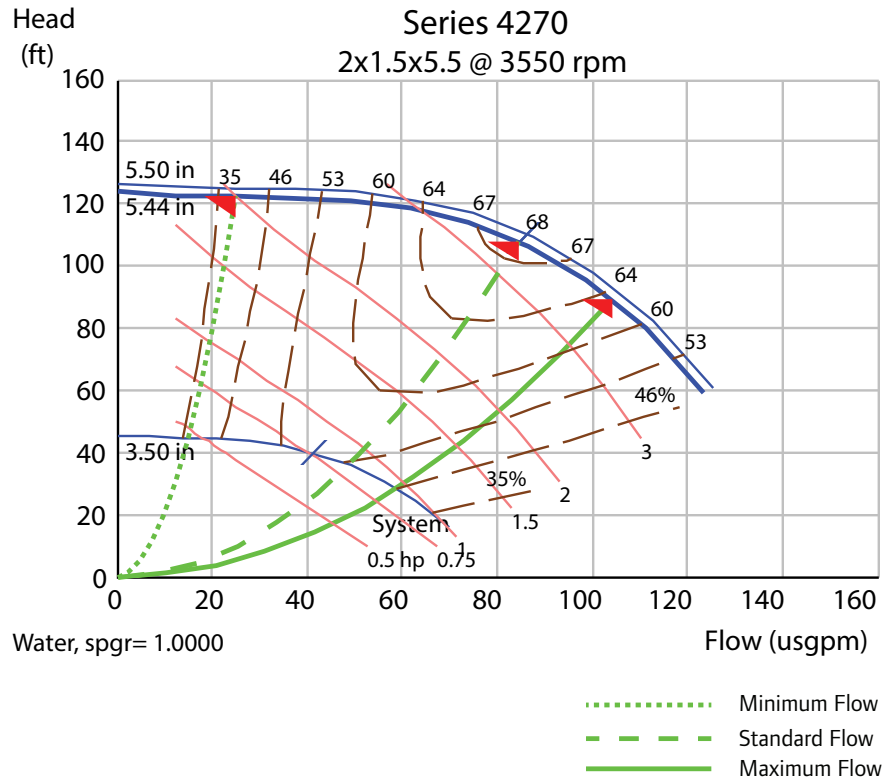

40 to 60 Ton CGAM

Table 81. Pump data

Labels	Values
Model Number	4280
Type	Close Coupled
Size	2 x 1.5 x 5.5 ^(a) ^(b)
Impeller Diameter	5.72 inches

^(a) Chiller inlet/outlet connections (40 ton) = 2.5 inch Victaulic

^(b) Chiller inlet/outlet connections (60 ton) = 4.0 inch Victaulic

Table 82. Motor data

Labels	Values
Type	TEFC
Horsepower	10
RPM	3600
Voltage	460
FLA	11.9 A

Table 83. Performance data

Labels	Values
Minimum	50 gpm @ 137.7 feet
Nominal Flow	173.4 gpm @ 115 feet
Maximum	201.6 gpm @ 104.1 feet

Figure 27. 40 to 60 ton CGAM pump curve

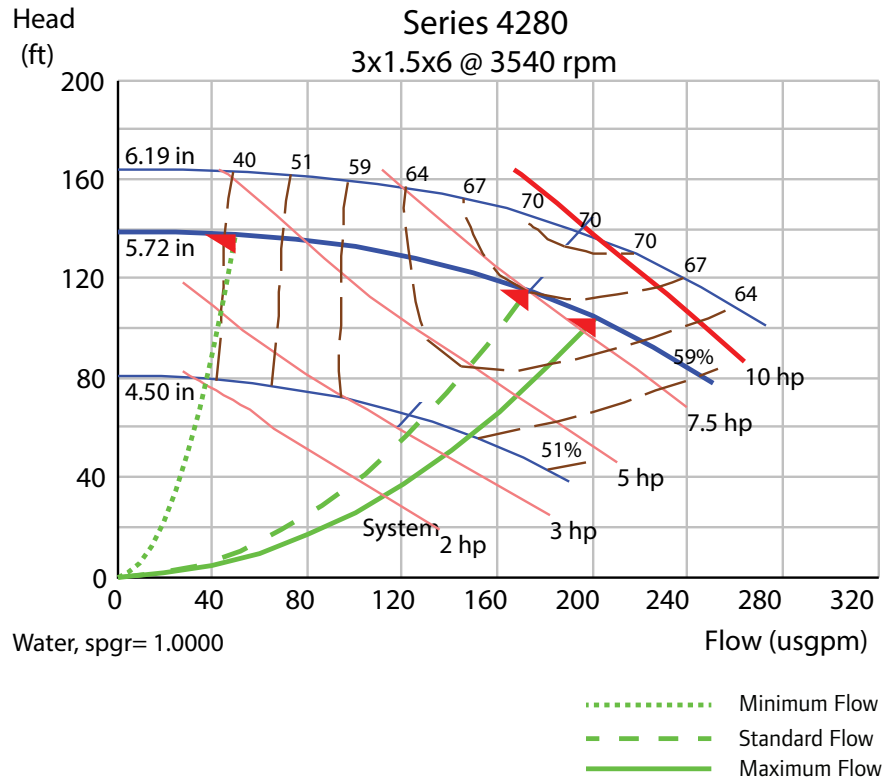

80 to 120 Ton CGAM

Table 84. Pump data

Labels	Values
Model Number	4280
Type	Close Coupled
Size	3 x 2 x 13 ^(a) ^(b)
Impeller Diameter	12.35 inches

^(a) Chiller inlet/outlet connections (80/100 ton) = 4.0 inch Victaulic

^(b) Chiller inlet/outlet connections (120 ton) = 6.0 inch Victaulic

Table 85. Motor data

Labels	Values
Type	TEFC
Horsepower	20
RPM	1800
Voltage	460
FLA	25 A

Table 86. Performance data

Labels	Values
Minimum	91 gpm @ 162.9 feet
Nominal Flow	304.4 gpm @ 144.2 feet
Maximum	376 gpm @ 124.5 feet

Figure 28. 80 to 120 ton CGAM pump curve

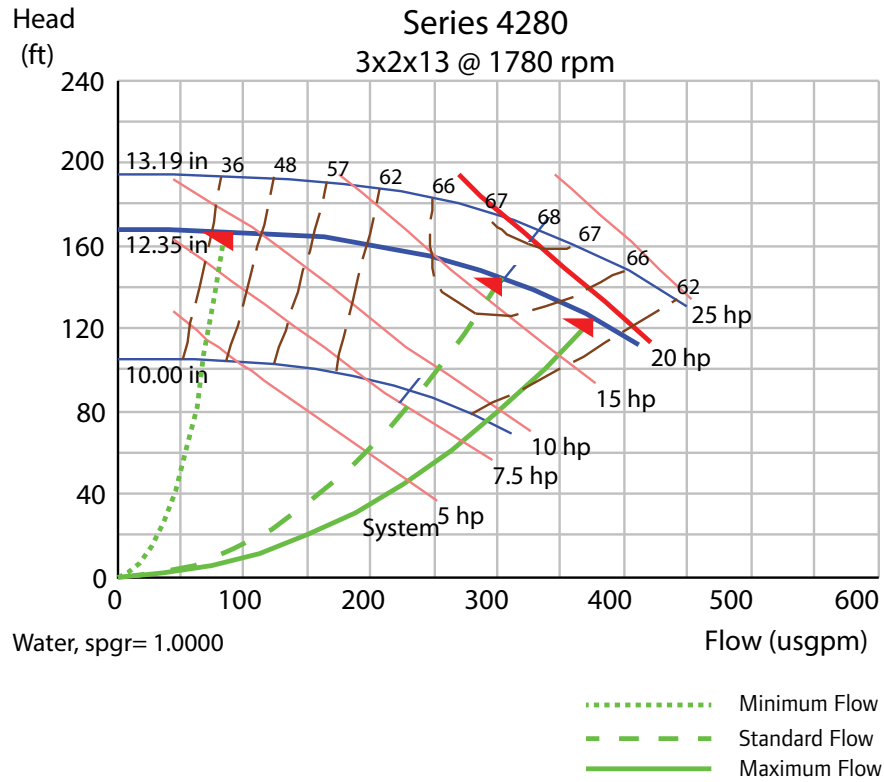

155/170/200 Ton RTAC (F0)

Table 87. Pump data

Labels	Values
Model Number	4280
Type	Close Coupled
Size	5 x 4 x 11.5 ^(a)
Impeller Diameter	11.3 inches

^(a) Chiller inlet/outlet connections = 6 inch Victaulic

Table 88. Motor data

Labels	Values
Type	TEFC
Horsepower	25
RPM	1800
Voltage	460
FLA	38 A

Table 89. Performance data

Labels	Values
Minimum	199 gpm @ 129.7 feet
Nominal Flow	677 gpm @ 112.9 feet
Maximum	800 gpm @ 93.1 feet

Figure 29. 155/170/200 ton RTAC (F0) pump curve

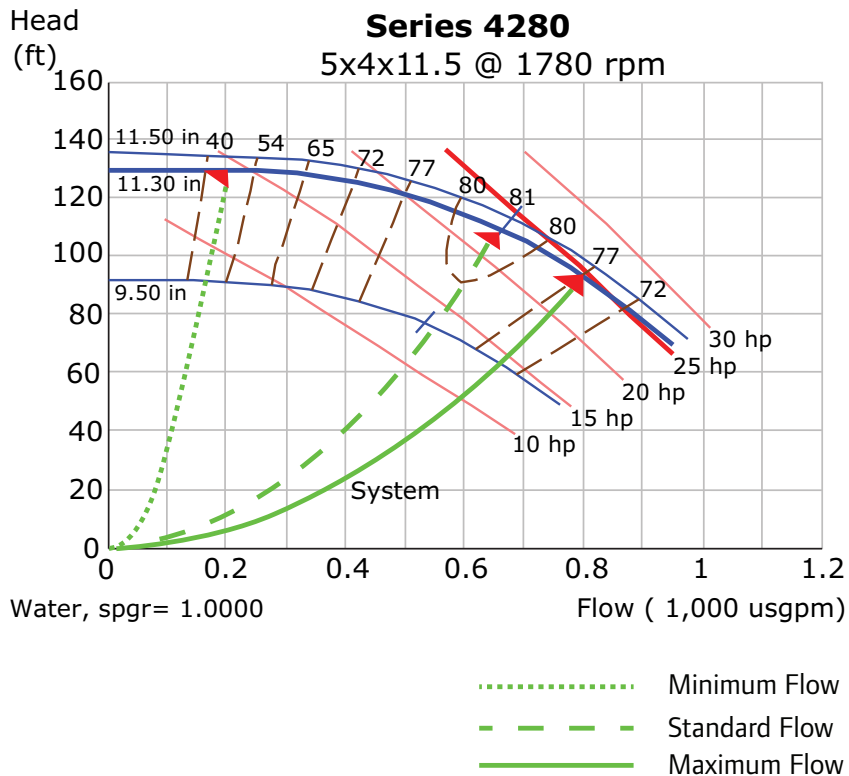



155/170/200 Ton RTAC (F2-F3)

Table 90. Pump data

Labels	Values
Model Number	4280
Type	Close Coupled
Size	4 x 3 x 13 L ^(a)
Impeller Diameter	11.87 inches

^(a) Chiller inlet/outlet connections = 6 inch Victaulic

Table 91. Motor data

Labels	Values
Type	TEFC
Horsepower	25
RPM	1800
Voltage	460
FLA	38 A

Table 92. Performance data

Labels	Values
Minimum	146 gpm @ 143 feet
Nominal Flow	485 gpm @ 119 feet
Maximum	606 gpm @ 99 feet

Figure 30. 155/170/200 ton RTAC (F2-F3) pump curve

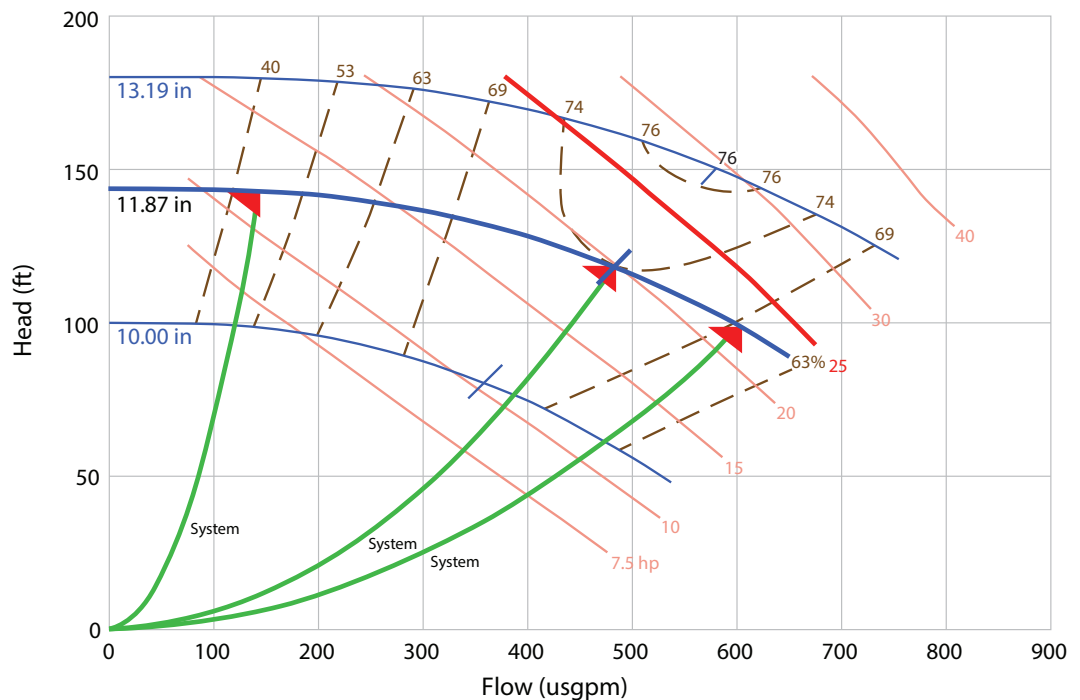

200 Ton ACSA (F0–F1)/200 Ton AXCA (F1)

Table 93. Pump data

Labels	Values
Model Number	4013D
Type	Split Coupled Vertical Inline
Size	4 x 4 x 13.5 ^(a)
Impeller Diameter	13.45 inches

^(a) Chiller inlet/outlet connections = 6 inch Victaulic

Table 94. Motor data

Labels	Values
Type	TEFC
Horsepower	40
RPM	1760
Voltage	460
FLA	48 A

Table 95. Performance data

Labels	Values
Minimum	181 gpm @ 190 feet H ₂ O
Nominal Flow	480 gpm @ 173 feet H ₂ O
Maximum	845 gpm @ 99 feet H ₂ O

Figure 31. 200 ton ACSA (F0–F1)/200 ton AXCA (F1) pump curve - single speed

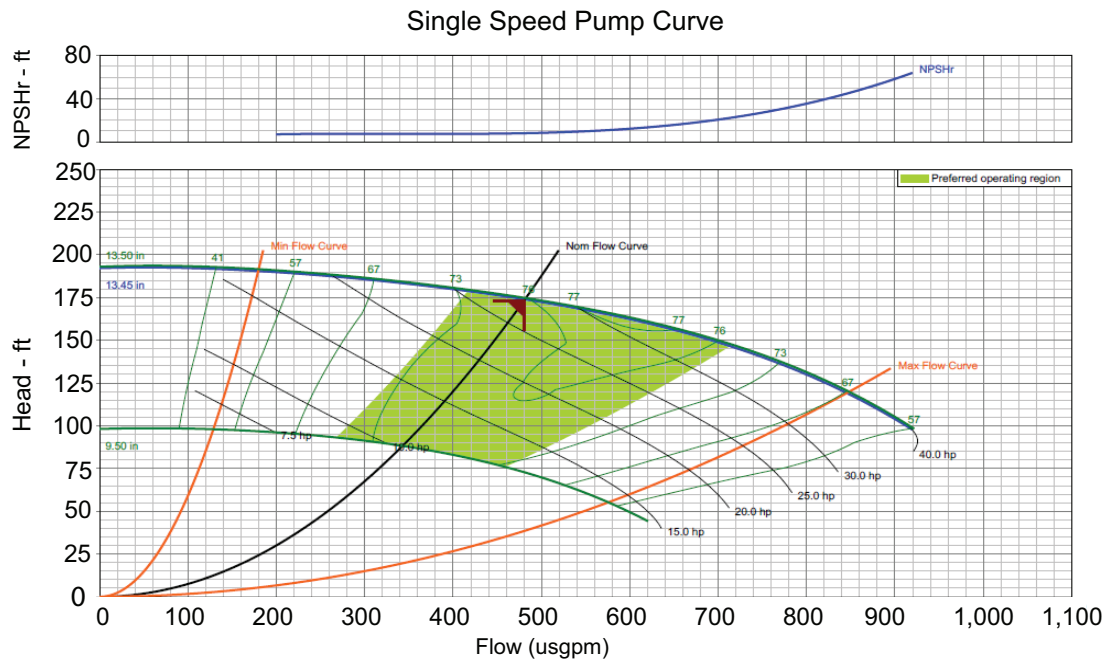
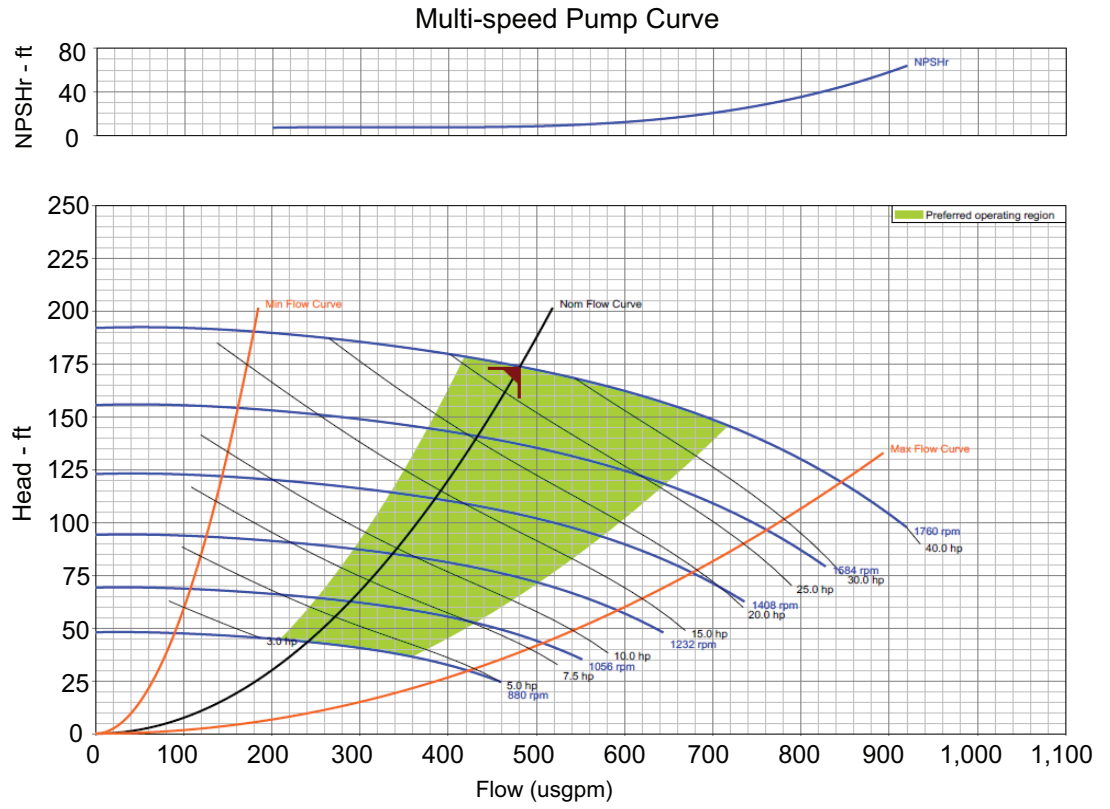

Figure 32. 200 ton ACSA (F0-F1)/200 ton AXCA (F1) - multi speed



250 Ton RTAC (F0)

Table 96. Pump data

Labels	Values
Model Number	4280
Type	Close Coupled
Size	6 x 5 x 11.5 ^(a)
Impeller Diameter	11.01 inches

^(a) Chiller inlet/outlet connections = 6 inch Victaulic

Table 97. Motor data

Labels	Values
Type	TEFC
Horsepower	40
RPM	1780
Voltage	460
FLA	53 A

Table 98. Performance data

Labels	Values
Minimum	259 gpm @ 116.9 feet
Nominal Flow	972.1 gpm @ 100.6 feet
Maximum	1253.6 gpm @ 82.7 feet

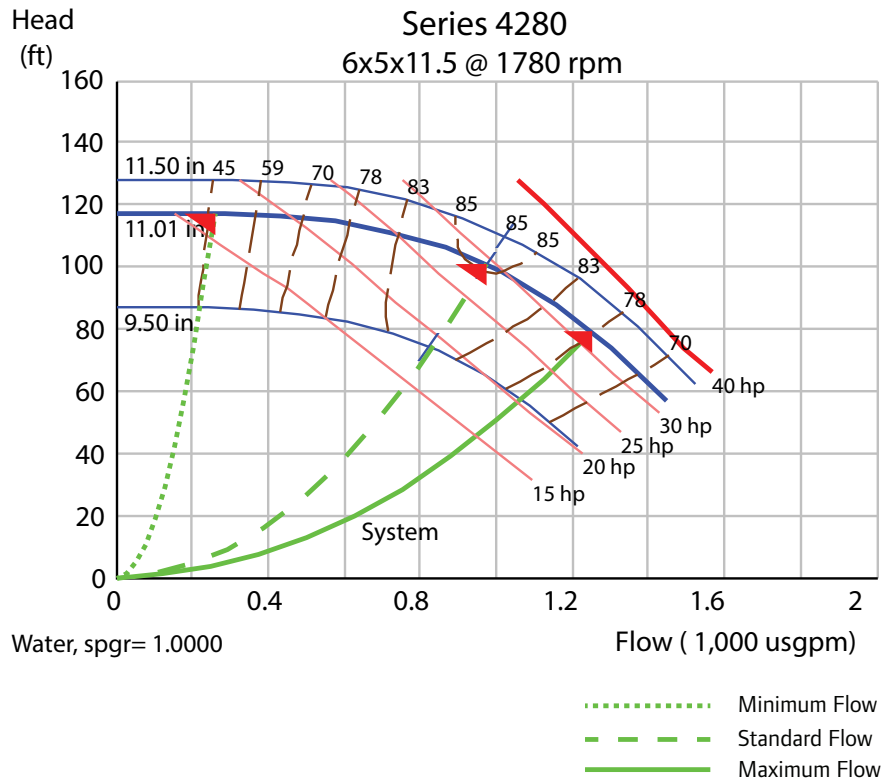
Figure 33. 250 ton RTAC (F0) pump curve

250 Ton RTAC (F2–F3)

Table 99. Pump data

Labels	Values
Model Number	4280
Type	Close Coupled
Size	6 x 4 x 3 ^(a)
Impeller Diameter	10.95 inches

^(a) Chiller inlet/outlet connections = 6 inch Victaulic

Table 100. Motor data

Labels	Values
Type	TEFC
Horsepower	30
RPM	1780
Voltage	460
FLA	53 A

Table 101. Performance data

Labels	Values
Minimum	210 gpm @ 123 feet
Nominal Flow	699 gpm @ 104 feet
Maximum	874 gpm @ 84 feet

Figure 34. 250 ton RTAC (F2–F3) pump curve

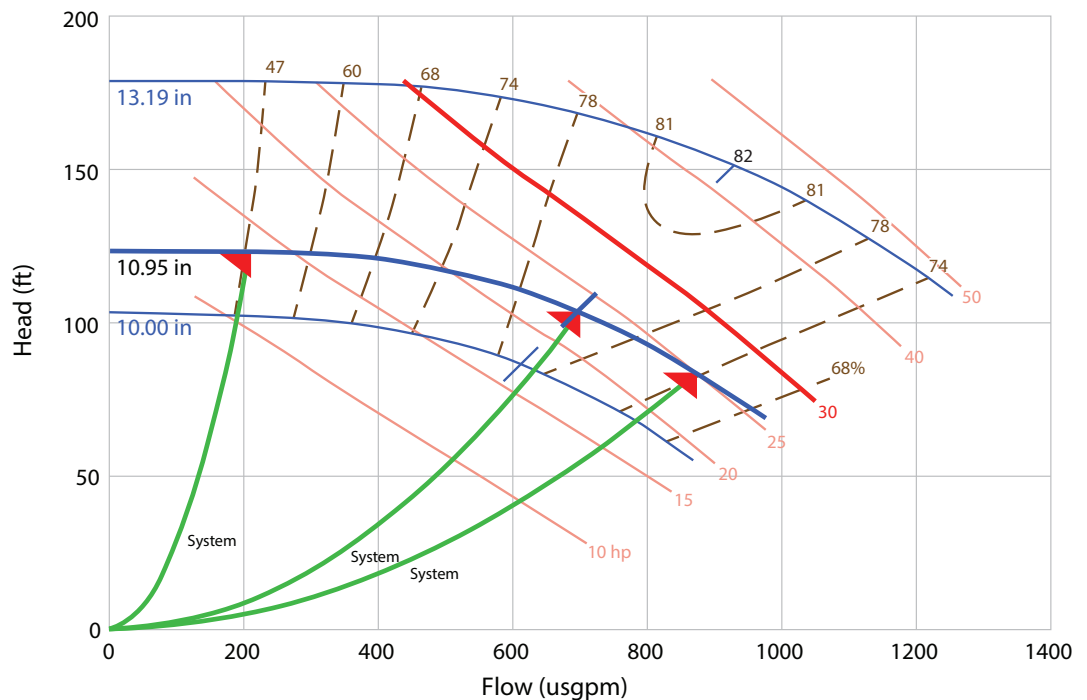

400 Ton RTAA and 300/400 Ton RTAC (F0)

Table 102. Pump data

Labels	Values
Model Number	4600
Type	Horizontal Split Case
Size	6 x 5 x 12H ^(a)
Impeller Diameter	11.75 inches

^(a) Chiller inlet/outlet connections = 6 inch Victaulic

Table 103. Motor data

Labels	Values
Type	TEFC
Horsepower	50
RPM	1800
Voltage	460
FLA	62 A

Table 104. Performance data

Labels	Values
Minimum	280 gpm @ 161 feet
Nominal Flow	934 gpm @ 138.3 feet
Maximum	1167.5 gpm @ 117 feet

Figure 35. 400 ton RTAA and 300/400 ton RTAC (F0) pump curve

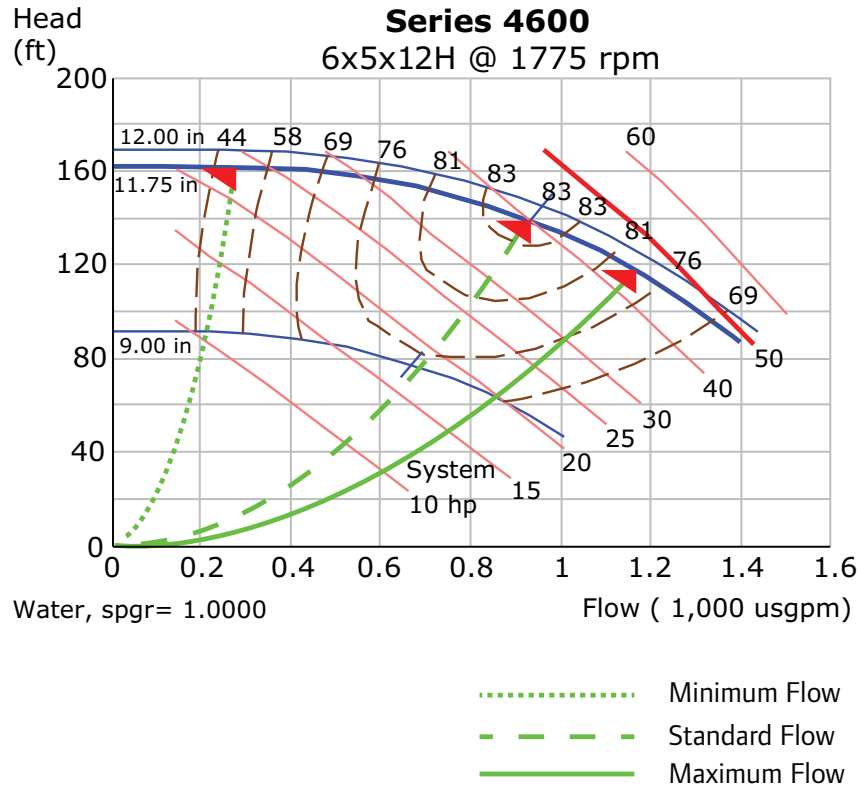

300/400 Ton RTAC (F2–F3)

Table 105. Pump data

Labels	Values
Model Number	4280
Type	Close Coupled
Size	6 x 5 x 13 ^(a)
Impeller Diameter	12.04 inches

^(a) Chiller inlet/outlet connections = 6 inch Victaulic

Table 106. Motor data

Labels	Values
Type	TEFC
Horsepower	50
RPM	1800
Voltage	460
FLA	62 A

Table 107. Performance data

Labels	Values
Minimum	357 gpm @ 142 feet
Nominal Flow	1190 gpm @ 114 feet
Maximum	1488 gpm @ 84 feet

Figure 36. 300/400 ton RTAC (F2–F3) pump curve

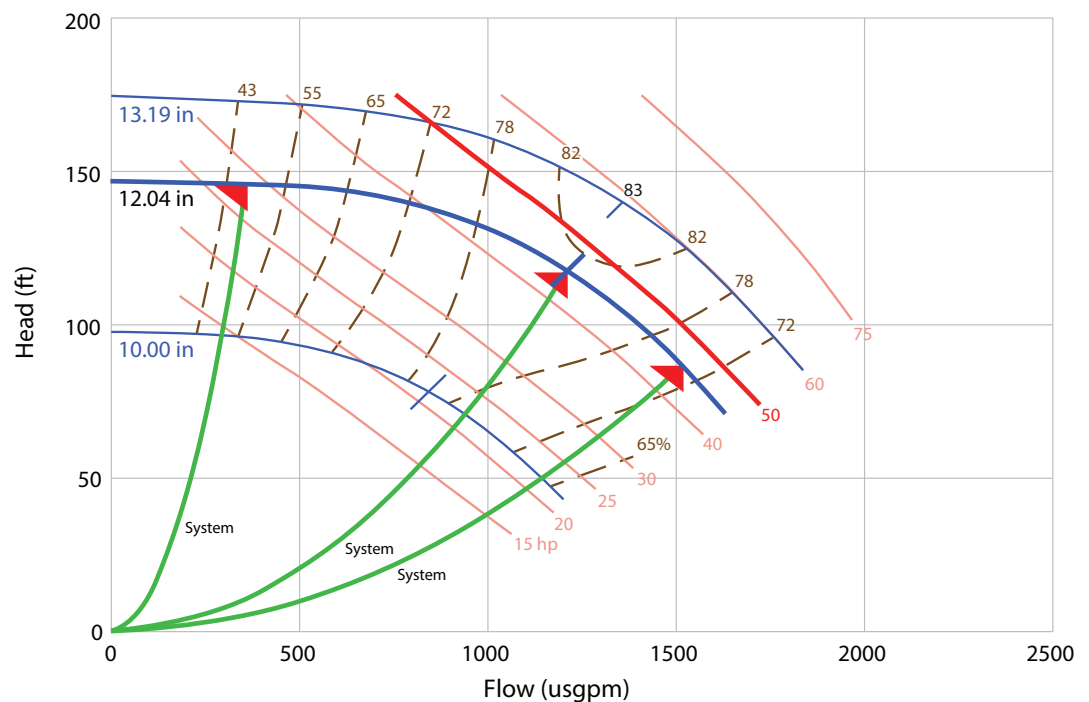



500 Ton RTAC (F0)

Table 108. Pump data

Labels	Values
Model Number	4600
Type	Horizontal Split Case
Size	8 x 6 x 12.5M ^(a)
Impeller Diameter	11.65 inches

^(a) Chiller inlet/outlet connections = 6 inch Victaulic

Table 109. Motor data

Labels	Values
Type	TEFC
Horsepower	50
RPM	1800
Voltage	460
FLA	62 A

Table 110. Performance data

Labels	Values
Minimum	370 gpm @ 142.5 feet
Nominal Flow	1234 gpm @ 112.8 feet
Maximum	1543 gpm @ 93.1 feet

Figure 37. 500 ton RTAC (F0) pump curve

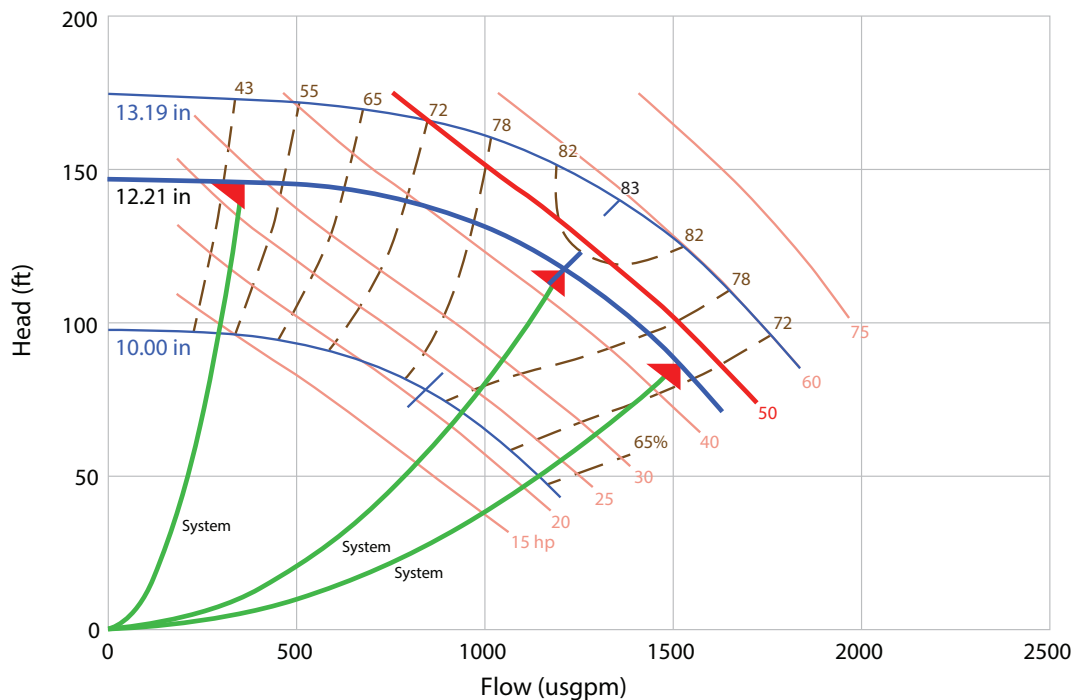

500 Ton RTAC (F2–F4)

Table 111. Pump data

Labels	Values
Model Number	4280
Type	End Suction
Size	6 x 5 x 13 ^(a)
Impeller Diameter	12.21 inches

^(a) Chiller inlet/outlet connections = 6 inch Victaulic

Table 112. Motor data

Labels	Values
Type	TEFC
Horsepower	50
RPM	1800
Voltage	460
FLA	62 A

Table 113. Performance data

Labels	Values
Minimum	365 gpm @ 146 feet
Nominal Flow	1217 gpm @ 117 feet
Maximum	1521 gpm @ 87 feet

Figure 38. 500 ton RTAC (F2–F4) pump curve

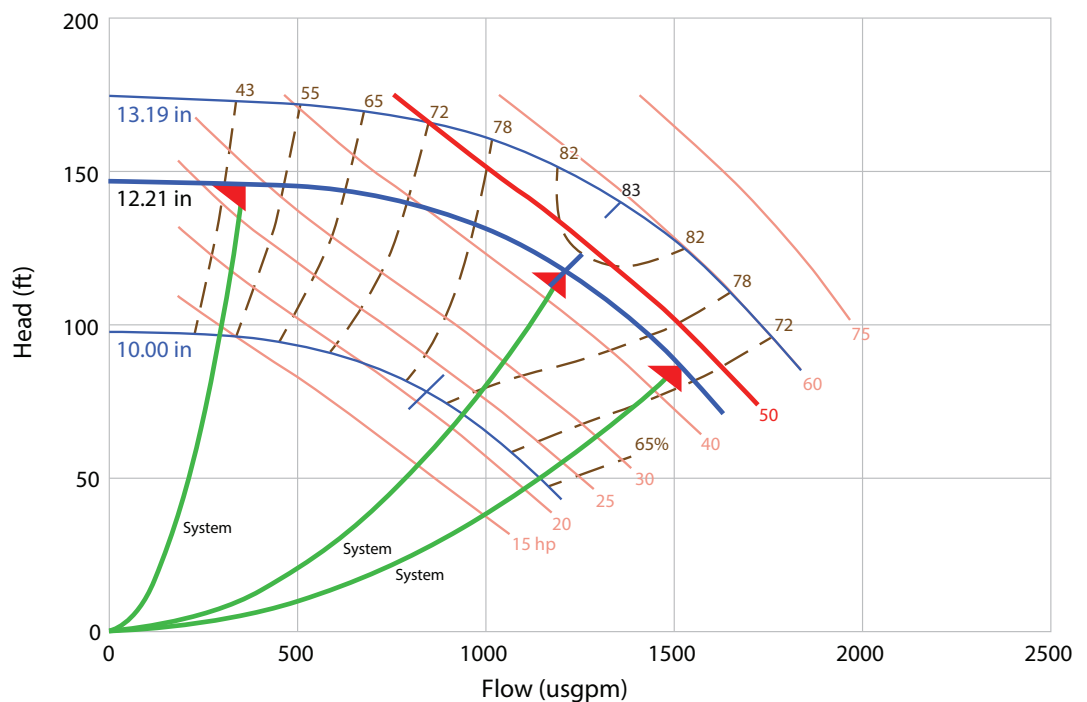

Trane - by Trane Technologies (NYSE: TT), a global innovator - creates comfortable, energy efficient indoor environments for commercial and residential applications. For more information, please visit trane.com or tranetechnologies.com.

Trane has a policy of continuous product and product data improvements and reserves the right to change design and specifications without notice. We are committed to using environmentally conscious print practices.

TEMP-PRC003A-EN 23 Oct 2024
Supersedes SRV-PRB005L-EN (August 2024)

©2024 Trane